





Digitized by the Internet Archive  
in 2016

[https://archive.org/details/jewelerscircular00unse\\_41](https://archive.org/details/jewelerscircular00unse_41)

Staatliche Uhrmacherschule

IV 1026



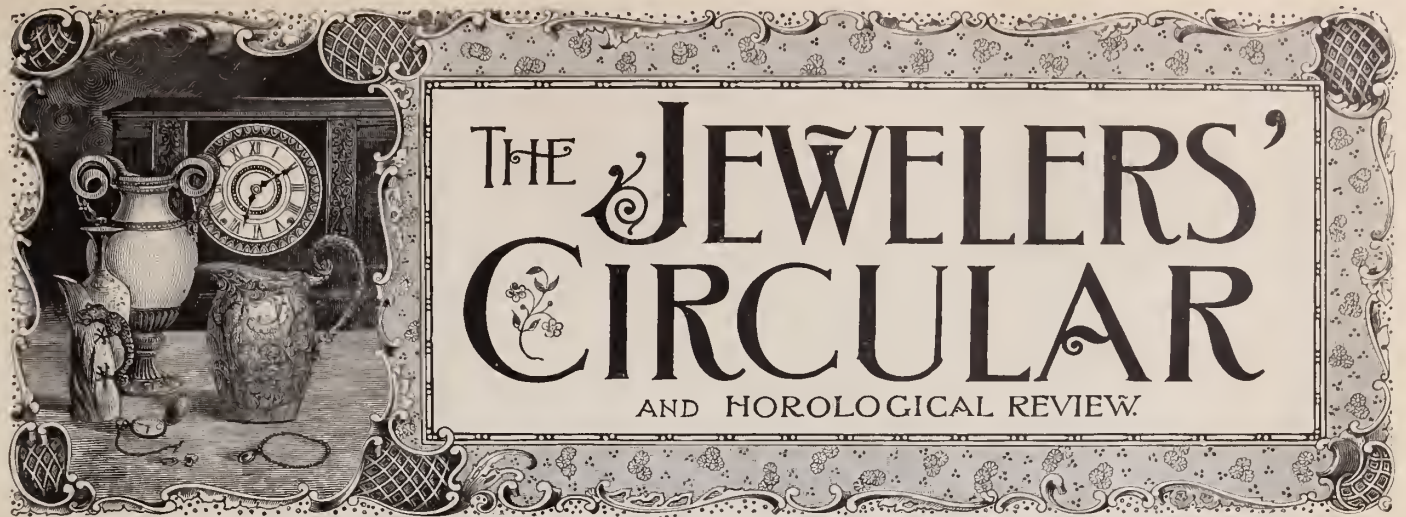

Corbin Building, 11 John St., Corner Broadway, New York.

Copyrighted by THE JEWELERS' CIRCULAR PUB. CO.

Entered at the Post Office in N. Y. as second-class matter.

VOL. XXXIX.

NEW YORK, WEDNESDAY, NOVEMBER 1, 1899.

No. 14.

## PRIZE COMPETITION IN CLOCK DESIGNING.

THE Society for the Advancement of Art and Industry, of Paris, chose the clock as a prize object for this year's exhibition. Ever and anon the salon mantel clock has enjoyed great popularity in France. Hence it was expected of the pupils of the art schools for whom the prize offer was intended, that they would furnish more or less perfect works. The recently opened exhibition of the pieces submitted in the halls of the Academy of Art, however, was fraught with bitter disappointment. It was obvious that the young generation of artists are not equal to the claims which must be made upon them as regards this branch of the art trades in order to meet Germany, England and Switzerland, which have far outstripped France. The 150 objects exhibited demonstrated, it is true, that their creators possess much imagination, but also little knowledge for using this imagination with deliberation. The "pendule" is an article of luxury pre-eminently for the drawing-room. Therefore, more attention must be paid to the material used than to the composition. A wooden case is fit solely for the ante-chamber. Porcelain with work cabinet. For the drawing-room the bronze case naturally suggests itself, patinized or gilt, in conjunction with crystal and enamel for the dial as well. The usual place for the clock in the salon is the mantel-piece. To use any other rest than the fireplace shelf would offend the eye. But if there is no other choice the resting place should be nothing but a bracket with a marble slab. The background as well as the surroundings require for the clock an imposing effect, solid architecture and substantial decoration, so as not to be choked by the candelabra and vases. All these requirements have been lost sight of by the competitors in the exhibition of salon clocks, and although one design has carried off the prize the result in general is a negative one for this branch of the French art trade.

The model of the illustration was awarded the third prize, 400 florins, at a prize offering by the Imperial and Royal Art Foundry of Arthur Krupp, Vienna, and will be exhibited, executed in bronze, at the World's Exhibition in Paris,



PRIZE CLOCK BY K. PHILIPP AND E. SIMBRIK OF VIENNA.

*To be exhibited at the Paris Exposition, 1900.*



ILLUSTRATION 1/4 SIZE.

**JEFFERSON PATTERN.**

- |                                |   |                                    |                               |
|--------------------------------|---|------------------------------------|-------------------------------|
| 1307 Coffee (6 half pints).    | 908 Large Cloth Brush.                  | 1153 Cigar Jar (Victoria pattern). | 1382 Cut Glass Pungent.       |
| 1306 Large Tea (5 half pints). | 912 Large Bonnet Brush.                 | 983 Small Puff Box.                | 922 Shoe Hook.                |
| 1302 Small Tea (1 1/4 pints).  | 904 Large Mirror.                       | 976 Paste Box.                     | 927 Shoe Horn.                |
| 1304 Large Sugar.              | 1015 Whisk.                             | 1201 Cut Glass Bon Bon.            | 918 Nail File.                |
| 1301 Small Sugar.              | 996 Comb.                               | 1292 Cut Glass Candle Stick.       | 1281 Cut Glass Violet Holder. |
| 1303 Large Creamer (1 pint).   | 916 Nail Polisher.                      | 1157 Heart and Crown Coin Box.     | 1284 Cut Glass Crown Salts.   |
| 1300 Small Creamer (1/2 pint). | 888 Manicure Scissors.                  | 1378 Ink (American Beauty).        | 1385 Cut Glass Cologne.       |
| 1305 Spoon Holder.             | 893 Bankers' Shears.                    | 1285 Cut Glass Pungent.            | 1023 Pin Tray.                |
| 906 Large Hair Brush.          | 1145 Large Puff Box (Victoria pattern). | 1381 Cut Glass Pungent.            |                               |

Send for our small catalogue showing our latest productions in sterling silver goods, and do not fail to call for some of those beautiful little Brooches we have just brought out.

**THEODORE W. FOSTER & BRO. CO.,**

100 RICHMOND STREET, - - - PROVIDENCE, R. I.

**A USEFUL NOVELTY**

**Bottle Openers,**

in Sterling Silver and Silver Plate. The convenience and cleanliness of this form of bottling having brought it into general use, these Openers will be appreciated for the table. Send for catalogue.

MADE BY

**Goodnow & Jenks,**

**SILVERSMITHS,**

Stanhope and Morgan Sts.,  
Boston,

who have obtained the SOLE RIGHT from patentees to manufacture this article.



# The Best.

## The "DOUBLE-BASE" Engraving Block

shown upon this page is regarded by the users of the same as the best block for the price, viz. :

### \$15.00,

on the American market. The attachments, consisting of Spoon Holder, Button and Bangle Attachments, Ring Holder, Cement Plates, 8 sets (4 each) Pins and Pegs, and Leather Pad, are more than are given with any other block. It is a better finished block and more work can be done with the same than with any other block offered for sale.

### An Absolute Guarantee Is Given With Every Block.

In addition to the above attachments, we can furnish you with a Thimble Holder (2 pieces) for 50 cents; Cane and Watch-Cap Holder (4 pieces) for 75 cents; Cement Plates from 25 cents to 50 cents, and Polished Hardwood Base, with drawer and glass shade, for \$3.50.

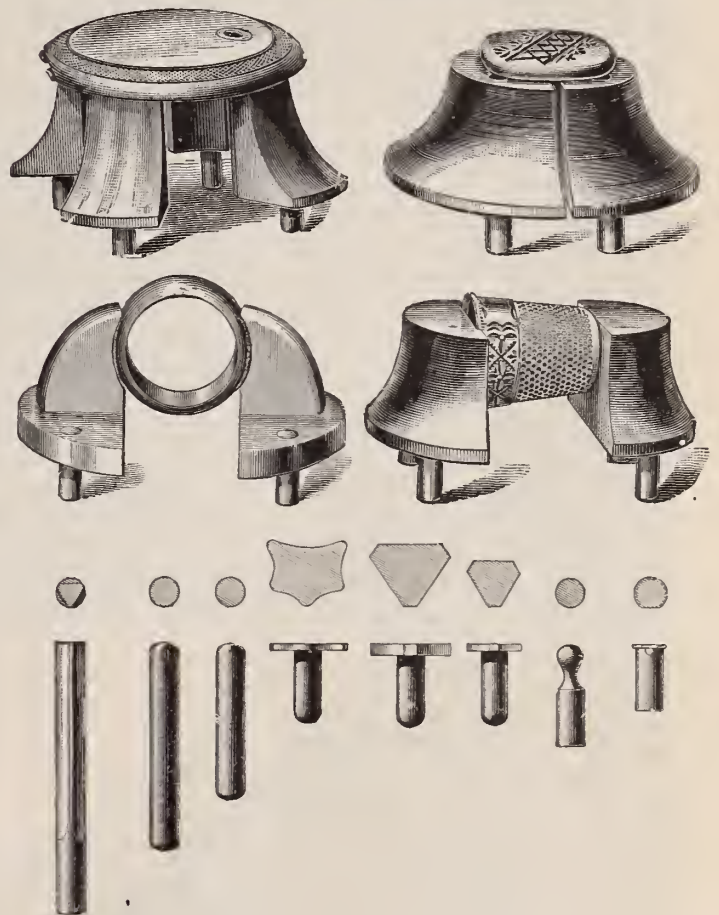
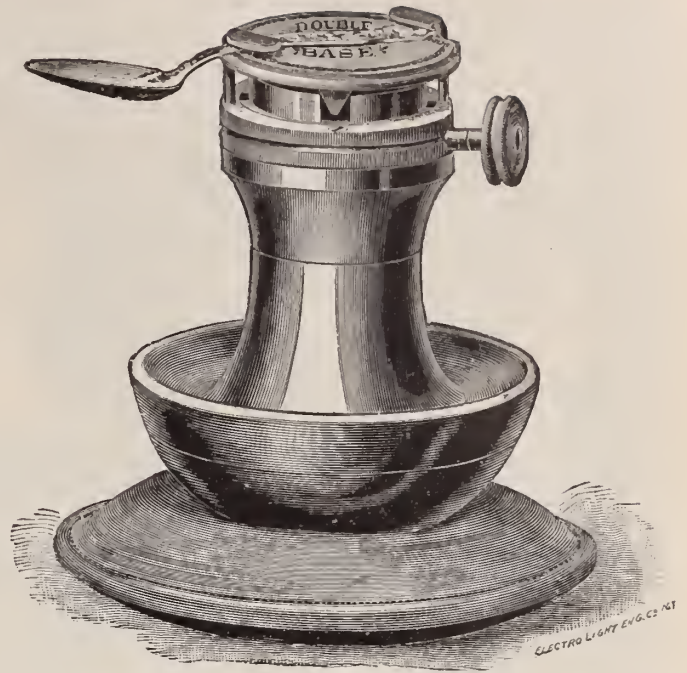

## L. C. REISNER & CO.,

Manufacturing Jobbers, Importers and Exporters,  
Watch Materials, Tools and Supplies,

Jewelry Repairers for the Trade.

LANCASTER, PA.



# RETAILERS!!

A good chain is cheap at any price. Our chains are good at a cheap price.

**Send for Selection and be Convinced**

Made only for the retail trade.

**THE BASSETT JEWELRY CO.,**



Successors to

**The Kent & Stanley Co., Ltd.,**

**PROVIDENCE,**

**R. I.**

THE BASSETT JEWELRY CO. HAS THE HONOR OF BEING THE SOLE MANUFACTURERS OF THE FOLLOWING LISTED CHAINS AND LINKS. ALL OTHERS ARE IMITATIONS. THE BASSETT JEWELRY CO. HAS THE HONOR OF BEING THE SOLE MANUFACTURERS OF THE FOLLOWING LISTED CHAINS AND LINKS. ALL OTHERS ARE IMITATIONS.

THE BASSETT JEWELRY CO. HAS THE HONOR OF BEING THE SOLE MANUFACTURERS OF THE FOLLOWING LISTED CHAINS AND LINKS. ALL OTHERS ARE IMITATIONS. THE BASSETT JEWELRY CO. HAS THE HONOR OF BEING THE SOLE MANUFACTURERS OF THE FOLLOWING LISTED CHAINS AND LINKS. ALL OTHERS ARE IMITATIONS.



# Silver Objets d'Art.

A few of our New Productions for the Holiday Season of 1899.



Jewelers who have experienced an increasing demand for the highest grade High Art Silverware, are advised to examine our lines.

*Prices on application.*



*"Watch Our Ads."*

## The Mauser Mfg. Co.,

...SILVERSMITHS...

15th Street, between Broadway and 5th Avenue, NEW YORK.



O. 257 Almond Dish and six Individual Dishes is one of the most popular combinations offered this season. These dishes are of good weight and are put up in attractive style in handsome silk or leatherette cases in several combinations, as follows: One Almond Dish and six Individual Dishes; One Almond Dish and twelve Individual Dishes; One Individual Dish; Two Individual Dishes; Six Individual Dishes and twelve Individual Dishes. The prices at which the above combinations are sold make them very desirable as leaders. Write us for prices.



## K. Wallace & Sons Mfg. Co.

Silversmiths

SALESROOMS: 226 Fifth Avenue, *New York*: 109 Wabash Avenue, *Chicago*:  
120 Sutter Street, *San Francisco*: 63 Basinghall Street, *London, E. C.*  
Main Office and Factory: *Wallingford, Connecticut.*

1900. The *motif* for the model is "the dying and the coming centuries." This has been solved in the present design in the most felicitous manner. The coming century, personified by a tender, virginal figure holding in the left hand the peace or olive branch while the right is uplifted as if greeting, stands upon the thigh of the God of Time, Chronos, who supports her with the left and with the right holds out the run down hour-glass to the passing century, which is represented by a kneeling feminine figure. Inquiringly the expiring century looks up to the approaching one, but the olive branch in the hand of the latter causes it to part tranquilly, and cheerfully it breaks the laurel to decorate the universe, which is represented by a globe. The substructure of the case proper of the clock is also architecturally beautiful. The artists were K. Philipp and E. Simbrik, of Vienna. [Text (not engraving) adapted from the "Gesamte Uhren Industrie."]

#### Moritz Herrman Remains at His Bench Till Death Overtakes Him.

NEW BRITAIN, Conn., Oct. 25.—Moritz Herrman, watchmaker, sat down for a few minutes' rest in his store at 85 Arch St. at 6 o'clock last evening, remarking to Thomas Woods, a barber, who shared the store with him, that he was ill. He had been ill for a month, but there were many watches to be mended, and he stuck to his work. Then there were nine children and a wife at his home, and three children more in the old country. These remained out of a family of eighteen; so he could not afford to be ill. He sat quietly for a few minutes, then arose and walked across the floor. Of a sudden he fell in a heap, and as the barber leaned over him he died.

Herrman was 57 years of age and had been in business on Arch St. for three years. The medical examiner said death was due to heart disease.

The business of Washburn & Rogers, Fort Myers, Fla., is now conducted by W. R. Washburn.

### Fashions in Jewelry, Silver Ware, Bric-à-Brac, Etc.

A LADY'S RAMBLES AMONG THE JEWELERS.

The heavy cloths, rich velvets and superb silks with which daytime jewelry will be associated this Winter make magnificence the keynote of the music which the jewelers are merrily piping and to which their patrons dance with right good will and pleasure. Daintiness and fragility of ornaments went into partial eclipse with the doffing of Summer chiffons. It is noticeable that many of the articles of daily wear are more massive or bolder in design, more elaborate in decoration, more striking in coloring—in short, of increased size and importance. Especially is this true of brooches and belt buckles, some of the former threatening to rival the too ample and sometimes awful proportions of the old-time brooches which our grandmothers clasped at their throats.

The present is to be a "ring season" unsurpassed in fashion's annals. So decree the mysterious powers that be. And in no line are jewelers showing more beautiful novelties. Foremost as a new *motif* in rings is the heart. Fine, large diamonds are cut heart shaped and, showing almost no mounting, are set upon a plain gold ring; magnificent opal hearts are framed with brilliants; the favorite turquoise comes bravely into view in heart shape and even the emerald is thus cut and lightly set in gold. A pink topaz heart makes an attractive ring.

The growing taste for the marquise ring has been already noted. Pink and other colored pearls, as solitaires, are among elegant rings. A striking ring consists of five diamonds in a straight bar crossing the hoop at right angles. The large opal stone of another ring is cut in a similar, long narrow form with slightly rounded corners and is surrounded with a double row of brilliants. Among inexpensive rings, fire opals in various combinations

with small brilliants are in favor, as are a small emerald or a ruby with one or more diamonds in graceful two and three stone designs.

The single heart that dangled at the end of the Summer girl's chain no longer suffices. She must now sport a "memory chain," which with its jingling collection of trophies sounds a paean of triumph wherever she goes. This is a fine and very long chain punctuated with small gems. To it is attached, upon a ring and much after the fashion of a bunch of keys, a motley assemblage of charms, the more the merrier and each one a gift. Emblems of good luck are usually among the number, such as an Egyptian scarabaeus, a four leaved clover, a lucky bean, a golden pig, an ivory elephant, a shoe, a spider, a rabbit; other items are a turquoise ball, a sphere of gun metal studded with brilliants, etc.

A novelty in men's all gold seal rings is one differing from the ordinary ring in that the surface of the portion usually devoted to the seal is slightly rounded instead of flat.

Beautiful grey suede purses and small bags are oblong, with flat silver or gilt frames ornamented with unique designs, such as a snake or a trailing vine. The fastening is the ball clasp.

Beaten silver is undoubtedly the last word in ornamental pieces of solid ware and as yet nothing supersedes the soft French grey finish.

The latest beading on otherwise plain silver stands out in such clean, clear cut relief as to afford the perfection of simple ornament.

White and gold china is again popular, but later is the introduction of a green ground on the border, which as a foil for the gold band is most fascinating.

ELSIE BEE.

# THE APOLLO

WARRANTS THE EPITHET "POPULAR,"

as shown by sales from Maine to Oregon.

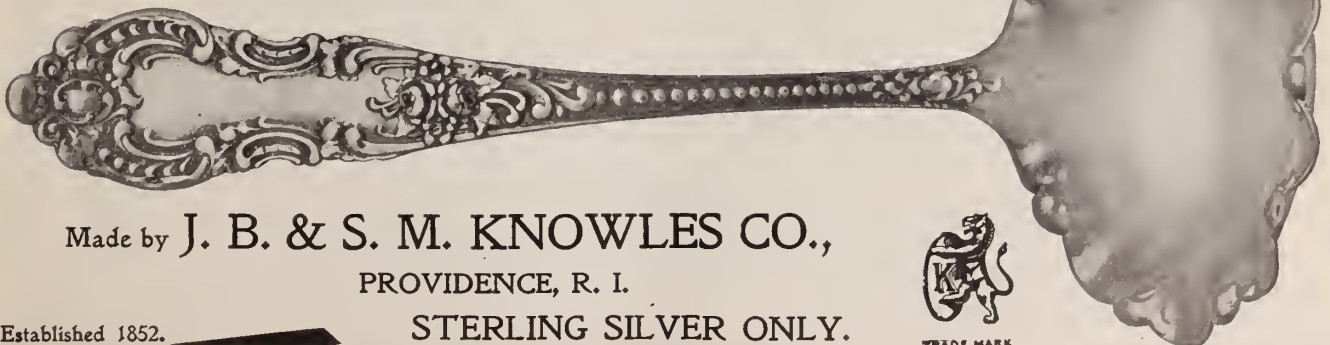

Made by J. B. & S. M. KNOWLES CO.,

PROVIDENCE, R. I.

STERLING SILVER ONLY.

Established 1852.





Bonbon Dish,  
No. 2142.

*"Sterling Silver Goods Only."*

This is only one of our new  
**BONBON DISHES**

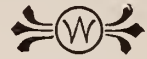

TRADE-MARK.

**FRANK M. WHITING  
& CO.,**

**Silversmiths,**

**NORTH ATTLEBORO, MASS.**

1128 Broadway, New York.

220 Sutter St., San Francisco.

Complete line of Samples always on display  
at our New York Office.

Our line of Dishes, Trays, Bowls,  
Tea Sets, Loving Cups, Toilet  
Goods, etc., is very complete  
this season.

## Of Greatest Importance

to the live manufacturing Jeweler is a careful  
consideration of our lines of Jewelers' Findings.

NEW ASSORTMENTS OF

**Buckles, Galleries, Brooches,  
Settings, Pins, Etc.**

**THOS. W. LIND,**

MANUFACTURER OF JEWELERS' FINDINGS,

67 FRIENDSHIP STREET,

PROVIDENCE, R. I.

**Imports and Exports of September, 1899, and the Preceding Nine Months.**

WASHINGTON, D. C., Oct. 30.—The summary statement of imports and exports for the month ended Sept. 30, 1899, and the

months ended the same date, compared with the corresponding periods of 1898, has been issued, and contains the accompanying figures relative to the jewelry trade:

**Canadian Importers Oppose a New Customs Regulation.**

MONTREAL, Que., Oct. 27.—F. Nelson, of H. A. Nelson & Sons Co., clocks, fancy goods, etc., Montreal and Toronto, was one of a committee recently appointed by the Montreal Board of Trade to inquire into a new customs regulation imposing duty on certain commissions. In the case of a merchant entrusting a commission man in the United States or in Europe to purchase goods for him the duties are charged, not only on the bill of goods but on the commission of 2½ or 5 per cent, or whatever it might be. This the committee considered unjust and recommended that Council should ask the Minister of Customs to receive a deputation of importers, who would explain to him the injustice of the order and the objections there are to its continuance.

**IMPORTS OF MERCHANDISE.**

ARTICLES.	SEPTEMBER.		NINE MONTHS ENDED SEPT. 30.	
	1898	1899	1898	1899
	Value.	Value.	Value.	Value.
	Dollars.	Dollars.	Dollars.	Dollars.
<b>CLOCKS AND WATCHES, AND PARTS OF:</b>				
Clocks and parts of.....dut..	33,392	46,650	164,976	207,420
Watches, watch materials, and movements.....dut..	96,936	101,251	568,923	779,714
<b>JEWELRY, MANUFACTURES OF GOLD AND SILVER, AND PRECIOUS STONES:</b>				
Diamonds, uncut, including miner's, etc., not set, free .....	236	332,870	1,582,545	3,696,096
Diamonds, cut, but not set.....dut..	610,141	901,090	4,252,761	7,407,473
Other precious stones, rough or uncut.....free..	318	2,452	22,493	39,168
Other precious stones, cut, but not set.....dut..	219,175	273,272	1,288,073	1,926,549
Jewelry, and manufactures of gold and silver.....dut..	307,606	488,295	1,514,994	3,540,363
Total.....	1,137,476	1,997,979	8,660,866	16,609,649
<b>PRECIOUS STONES, ETC. (free), imported from—</b>				
United Kingdom.....	480	302,751	757,873	2,837,123
France .....			54,235	18,957
Netherlands .....		32,457	771,949	869,815
Other Europe.....	74	114	14,633	7,562
Brazil .....			20	
Other countries.....			6,328	1,807
Total.....	554	335,322	1,605,038	3,735,264
<b>JEWELRY, AND OTHER PRECIOUS STONES, ETC. (dutiable), imported from—</b>				
United Kingdom.....	393,021	546,820	2,051,551	3,993,741
France .....	314,791	563,296	2,208,955	3,874,633
Germany .....	128,858	102,773	508,521	719,037
Netherlands .....	188,181	401,931	1,735,228	3,450,758
Other Europe.....	64,621	47,087	521,813	808,908
British North America.....	38	175	1,938	6,421
Mexico .....	611	261	4,243	15,584
East Indies .....	6,657		9,794	310
Other countries.....	10,114	314	13,785	4,993
Total.....	1,136,922	1,662,657	7,055,828	12,874,385

**Movement for Revision of the Customs Administrative Act.**

The Committee on Revision of the Customs Administrative Act appointed by the Merchants' Association of New York have commenced their work, and the executive board of this committee last week held a conference with United States District Attorney Burnett and his assistants together with General Appraiser H. M. Somerville.

Gen. Burnett explained the defects of the present customs laws, showing wherein it was difficult to secure a conviction for violations of the law under the present wording of the act. The changes necessary to insure to the Government, the domestic manufacturer and the honest importer the protection contemplated by the present tariff and at the same time to assure the prompt punishment of persons who sought to defraud the Government were discussed in detail. The various suggestions made will, upon approval by the full committee, be incorporated in the formal report to President McKinley, which will be made at an early date.

The General Committee on Revision now

**EXPORTS OF DOMESTIC MERCHANDISE.**

<b>CLOCKS AND WATCHES:</b>				
Clocks and parts of.....	70,495	91,813	692,659	820,828
Watches and parts of.....	55,650	50,361	631,033	488,360
Total.....	126,145	142,174	1,323,692	1,309,188
Jewelry .....	56,110	43,796	417,671	548,860
Other manufactures of gold and silver.....	19,250	29,430	154,331	167,430
Total.....	75,360	73,226	572,002	716,290
Plated Ware.....	45,993	46,350	280,319	343,104

H £

We Manufacture  
 Knives, Forks, Spoons and Cutlery.  
 Hollow Ware, Toilet Ware and Manicure Pieces.  
 The Kind that is sought in Jewelry Stores  
 Not found elsewhere.

**HOWARD STERLING CO**  
 Silversmiths.  
 Providence · New York · San Francisco.

numbers some 40 gentlemen, representing different interests in all sections of the country. Ludwig Nissen, of Ludwig Nissen & Co., represents the precious stones industry on this committee.

#### Single Line Merchants of Kansas City Organize Against the Large Stores.

KANSAS CITY, Mo., Oct. 28.—The single line merchants at a meeting held at the Midland hotel this week formed a temporary association to be perfected at a larger meeting to be held Oct. 30. Nearly every branch of business was represented, and the plans contemplated are a big consolidation of interests. An effort is to be made to make the 4,000 or more single line merchants as an organized body wage war on the departmental stores. All of the speakers favored making an attempt to enforce the store tax law now on the statute books and maintaining a lobby to get a supplementary act passed if the present law shall fail to produce the results desired.

To organize the different lines committees were formed of which the following are chairmen: Furnishing goods, M. D. Stevens; drugs, W. F. Federman; boots and shoes, John P. O'Neil; hats, G. H. Michaels; jewelry, F. W. Meyer; hardware, H. A. Brunner; furniture, Robert Keith; paint, H. E. Cramer; groceries, H. N. Yates.

Information was filed this week in the criminal court of Jackson county by F. C. Farr, the license commissioner, charging W. B. Thayer, as manager of Emery, Bird, Thayer & Co., with having operated a department store in Kansas City on Oct. 15 without a license. It sets out that the firm sold on the same day dry goods, clothing, boots and shoes, groceries, furniture, carpets, crockery, stoves, books, toys, hats, millinery and jewelry.

M. Putney, Ottawa, Ill., is out of business.

#### Henry Terheyden Gets the Stock of Geo. W. Biggs & Co.

PITTSBURGH, Pa., Oct. 28.—The case of George W. Biggs & Co. came up in court on Tuesday, Oct. 24. The temporary receiver, Mr. Stoner, presented a petition asking that he be allowed to sell the stock in trade to the highest bidder. Bids, he said, had been received from five reputable persons, and he deemed the best bid a fair one, and the two highest bidders were in court. They were Henry Terheyden and A. E. Siedle.

The attorneys for both sides held a consultation, and this was followed by an impromptu auction. The highest bid up to the time of holding the auction in court was \$5,100, but before the auction closed a bid of \$6,800 had been secured from Henry Terheyden, and the Court ordered the property sold to him. A. E. Siedle's bid was \$6,750. Up to the time of the hearing \$2,000 worth of goods had been sold by the receiver, making the sum total \$8,800. The stock had been invoiced by Joseph Buerkle at \$8,500.

A meeting of the creditors will be held on Oct. 31.

#### Traveler John Hagan the Victim of Amateur Detective Work.

ST. LOUIS, Mo., Oct. 28.—Abraham Gallaut, a pawnbroker at 15th and Market Sts., was the victim of a confidence game on the 25th. A man called at his store and told him he had a diamond to sell, at the same time unfolding a tale of woe. He showed the stone to Gallaut, who is considered an excellent judge of diamonds, and asked what would be the top price he would give for it. Twenty-five dollars was the maximum offered. He took the stone back and said he would never let it go at that figure. But on mature reflection he said he had to have money, and threw the

stone over the counter. Gallaut handed him over the \$25. The man got out of the store quickly, and then the pawnbroker found he had been fleeced, having been given a bogus stone and not the one he originally examined. Much exasperated he told his clerk, who had come in but who had not seen the swindler, the particulars, and giving him a description of the man, sent him out to trace him. The clerk got on what he thought was a "warm trail," and shadowed whom he thought was the swindler through various jewelry stores, finally winding up at Bauman-Massa Jewelry Co.'s establishment. He told a policeman he desired him to arrest the man he pointed out, who proved to be John Hagan, a salesman for E. L. Spencer & Co., Providence, R. I. Aiter listening to the excited pawnbroker's assistant, also to Mr. Hagan, who identified himself by his card as well as by members of the firm of Bauman-Massa Jewelry Co., with whom he is well acquainted, the policeman refused to make the arrest, much to the chagrin of the would-be detective, who finally admitted he might be mistaken, having only a verbal description of the swindler. Mr. Hagan may prosecute.

#### British Supremacy in South Africa a Boon to America.

WE experience no trouble with the United Kingdom, because that is a free trade country. For this reason I would like to see Great Britain have the support of the United States, and I frankly believe the general progress of the world would be benefited by British supremacy in South Africa. What we want in foreign lands is an open market and no favors, and England comes very near giving that wherever she holds sway.—Robert P. Porter in an interview in the *New York Times*, Oct. 29.

## Gifts for Men



TRADE-MARK.

Gold Cigarette Cases,  
Gold Match Boxes,                      Ornamented with Diamonds  
Gold Cigar Cutters,                      and Precious Stones.  
Gold Pocket Knives,

HIGH-CLASS NOVELTIES of all kinds in Gold and Silver, made handsomely, heavy and exclusively for the Jewelry Trade.

**Woods & Chatellier,**  
Gold and Silversmiths.

860 Broadway, N. Y.

42-46 Hill Street, Newark, N. J.

# LEATHER GOODS!

<b>Walrus Hide,</b>	12 Colors,	Gun Metal Jeweled Mounts.
<b>Sea-Lion,</b>	8 Colors,	14 k. Gold Jeweled Mounts.
<b>Monkey Skin,</b>	24 Colors,	Grey Finish Mounts.
<b>Elephant Hide,</b>	5 Colors,	Green Gold Mounts.

## TRAVELING BAGS,

Plain and with Fittings of

**IVORY, EBONY, SHELL.**

## TOURIST ROLLS,

with Ivory and Ebony Sterling Mounted Fittings.

## CHATELAINE BAGS,

Antique Dutch, Sterling Silver, Gun Metal.

Mounted in Velvet, Lizard, Sea-Lion, Monkey, Seal.

**Military Purses,** English Pigskin, Brass Letters, Monograms.

**Ebony Toilet Goods.**

One Quality—The Best.

**Ivory Toilet Goods.**

Unlimited Variety.



# DEITSCH BROS.,

14 East 17th St.,

New York.

# "THE AMERICAN BEAUTY"



IN

## Sterling and Essex

UNEQUALED.

## Hayden Mfg. Co.,

21-23 MAIDEN LANE,  
NEW YORK.

### Tariff Decisions & Regulations

PARCELS POST BETWEEN UNITED STATES AND GERMANY.

WASHINGTON, D. C., Oct. 27.—Exporters and importers will be interested in the following regulations prescribed by the Treasury Department relative to the parcels post convention concluded Sept. 2, 1899, between the United States and Germany:

The regulations provide that there shall be admitted to the mails exchanged under the convention articles of merchandise and mail matter—except written matter of all kinds—that are admitted under any conditions to the domestic mails of the country of origin, except that no packet must exceed 11 pounds in weight nor the following dimensions: Greatest length in any direction, 3 feet 6 inches; greatest length and girth combined, 6 feet—and must be so wrapped or inclosed as to permit their contents to be easily examined by customs officers and by postmasters duly authorized to do so.

The packages shall be subject in the country of destination to all customs duties and customs regulations in force in that country for the protection of the customs revenue. The sender of each package must make a customs declaration, upon a special form provided for the purpose, giving the address, a general description of the parcel, an accurate statement of the contents and value, date of mailing and the sender's signature and place of residence.

#### Death of Isaac Nepel.

NEW HAVEN, Conn., Oct. 29.—Isaac Nepel, a well known aged jeweler of this city, died yesterday afternoon, after a long illness, at the home of his daughter, Mrs. Solomon Goldbaum. He was in the 86th year of his age. He was the oldest Israelite in New Haven. He was a brother of jeweler Jacob Nepel, of New York, who for many years was proprietor of a New Haven jewelry store. He leaves one son, Abraham Nepel, three daughters and many grandchildren and great grandchildren. The deceased was one of the best known goldsmiths of New Haven. He had resided here 35 years. The funeral services took place to-day and were largely attended.

#### The Silversmiths and Jewelers of Herman Keck Mfg. Co. Go on Strike.

CINCINNATI, O., Oct. 28.—The diamond cutters of the Herman Keck Mfg. Co. having just returned to work, after securing a satisfactory adjustment of their difficulties, all the silversmiths and jewelers in the factory, numbering about 30, have gone out on strike.

Mr. Keck, when seen, would not discuss the matter, but the men say they have been treated badly and refuse to stand the treatment any longer. The firm have been losing goods, and last week a valuable die was stolen. A detective was employed, and one night this week the men were lined up and an investigation begun. They indignantly protested against this and refused to work where they are suspected. Some of them have been in the factory for many years and their honesty has never been questioned. One man was discharged without sufficient cause, they say, and they all went out and have been holding meetings to determine what to do in the matter.

#### Death of Albert M. Pine.

PROVIDENCE, R. I., Oct. 28.—Albert M. Pine, who for 25 years had been in the employ of the George L. Vose Mfg. Co., died at his home in Riverside, this week, after an illness of about a fortnight. Mr. Pine was the son of Henry S. and Louise Pine, and was born in Attleboro, Mass., Aug. 13, 1854. He came to this city at an early age, and after receiving a common school education entered the establishment of William C. Almy & Co., manufacturing jewelers, as an apprentice. After learning the trade he entered the employ of George L. Vose & Co., now Geo. L. Vose Mfg. Co., and for a period of nearly 25 years had been a trusted employe there. About a year ago he was made foreman of their shop.

Mr. Pine was quite prominent in secret society circles, being one of the charter members of Riverside Lodge, No. 21, K. of P., and passed through the various chairs, finally entering the Grand Lodge. For the past six years he had been Master of Finance. He was also a member of Westminster Lodge, No. 27, I. O. O. F., and was a member of other organizations. He leaves a widow, two daughters and one son.

## MATHEWS & PRIOR,

DESIGNERS AND MAKERS OF

## Sterling Silverware

TO THE LEGITIMATE

## JEWELRY TRADE ONLY,



245-247 West 28th Street,  
New York City.



### National Export Exposition.

#### Awards Soon to Be Made—Mercantile Interests Surprised at Its Scope—Opticians Indignant.

PHILADELPHIA, Pa., Oct. 29.—Judges will be appointed this week to make the award of medals to be distributed for the best exhibits at the National Export Exposition. The awards to be recommended are: Silver or bronze medal of the Franklin Institute, with accompanying diploma, or certificate of honorable mention. In case of exhibits possessing unusual merit, the judges may, in their discretion, recommend reference to the Committee on Science and Arts of the Institute for the award of the Edward Longstreth medal of merit, the John Scott legacy premium and medal, granted by the Board of Directors of City Trusts, or the Elliott Cresson medal. These awards will be made under the regulations as set forth in the by-laws of the Institute. Other awards are to be made by the officials of the Commercial Museum and the city and Government authorities.

The officials of the Exposition have been apprised by their agents abroad that British merchants and commercial bodies are watching the progress of the International Commercial Congress with unfeigned interest. The exhibition of foreign samples collected for the benefit of the home manufacturer, which was described in the last issue of THE CIRCULAR, is regarded as striking proof of American commercial alertness, and the papers of England are urging the London Board of Trade to

adopt such a scheme. Incidentally Director General Wilson has been notified that a very meaning coincidence was the opening last week in London of an intelligence branch to the commercial department of the Board of Trade. The chief of this department is Llewellyn Smith, now in this city, an active participant in the Congress. This department is the outcome of a report of a parliamentary committee which urged the necessity of collecting British and foreign diplomatic and consular commercial reports, hitherto scattered through the various government offices, thus rendering them available to the manufacturers. Mr. Smith explained that: "My report to the London Board of Trade of the immense collection of samples of foreign goods in this city was a perfect surprise to British merchants, though Parliament once granted us \$500 to enable the consuls to make a similar collection."

Considerable indignation is manifested in legitimate optical circles in this city by the action of the Exposition authorities in permitting a number of alleged optical concerns to rent large floor spaces for the exhibition and sale of optical goods, which firms, it is stated, have no establishments and are totally unknown to the legitimate trade. One member of one of the leading optical concerns in Philadelphia remarked to THE CIRCULAR correspondent, Saturday, that "these exhibits do incalculable injury to the legitimate trade. They are frauds, and visitors to the Exposition are swindled into purchasing worthless goods at high prices by the glib-tongued demonstrators at these booths. None of the

standard firms, who have exhibits there, sell at retail. The greatest injury is done to the American trade, particularly by the swindling of 'innocents' to the Commercial Congress from abroad. Last week one of these 'demonstrationers' who had met an English delegate at the sessions of the Congress, sold to him a pair of filled spectacles for \$20. This is only one of a number of similar swindles." The matter will be presented to the executive committee of the Pennsylvania Optical Society for action at its next meeting, and resolutions will doubtless be adopted, censuring such practices.

A long and interesting address on the subject "American Railroads" was delivered Wednesday, by Geo. H. Daniels, general passenger agent of the New York Central & Hudson River R. R., at the International Commercial Congress now in session here. Wednesday was designated Expansion Day at this congress, and Mr. Daniels, who is president of the American Association of General Passenger Agents, was requested to make an address on American Railroads, touching their relation to commercial, industrial and agricultural interests. This he did in an elaborate essay, in which he also reviewed all the recent and current events in all parts of the world relating to the subject.

Coon & Potter's store, Fayetteville, N. Y., was broken into some nights ago and a large amount of jewelry and a few other articles were taken. The burglars effected an entrance by prying open the front door.

## Holiday Goods.

### To the Trade:

We present our stock of goods to the attention of the Jewelry Trade with the assurance that it is not surpassed in extent, character or price.

**MAKE SELECTIONS NOW FOR THE HOLIDAYS.**

**STERLING SILVER:** Toilet Ware, Desk Goods, Novelties, Flat Ware, Hollow Ware.

**UMBRELLAS, WALKING STICKS, CROPS AND WHIPS:** Exclusive designs in Silver and Gold, some richly jeweled. Delicate Ivory Carvings, Stag Horn, Ivory and Natural Woods, mounted with unique and original designs.

**LEATHER GOODS:** Traveling Bags, with and without Toilet Fittings; Pocketbooks, Card Cases and Chatelaine Bags, mounted in Silver and Gold; Portfolios and Desk Pads, mounted in Silver.

We control and make a full line of goods in Walrus and Buffalo Leather.

ORDERS WILL RECEIVE PROMPT ATTENTION.



**Gorham Mfg. Co., SILVERSMITHS,**  
Broadway and 19th Street, New York City.

BRANCHES—New York, 21-23 Maiden Lane.

Chicago, 131-137 Wabash Ave.

San Francisco, 118-120 Sutter St.

WORKS—Providence, R. I., and New York.

**A Jewelers' Trust Company.**

**Prominent Jewelers Organizing Trust and Safe Deposit Companies for Jewelers' Needs.**

There has been on foot for some time in New York a movement which is now assuming definite form to have a safe deposit and a trust company in the jewelry trade, which will be devoted particularly to the needs of this line of business. Among the men who are now identified with the movement are some of the most prominent merchants in the wholesale diamond, watch and jewelry business, as will be recognized when it is stated that the following gentlemen are backing the scheme: Augustus K. Sloan, of Sloan & Co. and president of the Jewelers' Association and Board of Trade; Ludwig Nissen, of Ludwig Nissen & Co., president of the Manufacturers' Association of Brooklyn; Geo. E. Fahys, of Jos. Fahys & Co. and president of the Brooklyn Watch Case Co.; Alfred H. Smith, of Alfred H. Smith & Co., diamond importers; David Untermeyer, of the Keller & Untermeyer Mfg. Co., and Henry Hayes.

The objects and scope of the proposed safe deposit and trust companies and the particulars as to capitalization, etc., are fully outlined in the following prospectus:

PROSPECTUS.

It is proposed to organize in the city of New York a trust company and a safe deposit company. They are to be legally distinct, but to be owned, as far as practicable, by the same persons and to be operated in harmony. The names selected

for them are the Sterling Trust Company and Safe Deposit Company. Both will be located in a building to be erected for the purpose in the neighborhood of the corner of Maiden Lane and Nassau St.

Capital of the Trust Company....	\$750,000
Surplus .....	750,000
Total .....	\$1,500,000
Capital of the Safe Deposit Company .....	150,000

The stock of the Trust Company will be divided into 7,500 shares of the par value of \$100 each, offered for subscription at \$200.

The stock of the Safe Deposit Company will be divided into 1,500 shares of the par value of \$100, offered for subscription at par.

In order to secure a fair division of interest in the two concerns each subscriber to five shares of Trust Company stock will receive an option to take one share in the Safe Deposit Company. Because of the important part which the latter will play in the special business for which primarily the two companies are formed, and its small number of shares, its stock is expected to prove particularly valuable.

Both corporations will be organized under the New York Banking law, and will be empowered to transact every variety of business permitted by that law to institutions of their respective characters.

The Trust Company will be authorized to act as fiscal or transfer agent for municipal or private corporations, to receive deposits of money and personal property and make loans on real and personal securities; to act as trustee for corporate mortgages; to accept all lawful trusts created by will, deed or order of court, as ex-

ecutor, administrator, guardian, receiver, or committee or trustee for married women, infants or incompetents; to act as legal depository of moneys paid into court; to accept active trusts with respect to real estate; to buy and sell real and personal securities of every nature, and to do a general banking business.

In addition to the usual lines of business common to older companies it will, through a committee of its directors composed of recognized experts in the jewelry trade, examine and appraise jewelry; lend upon warehouse receipts, for stones, manufactured jewelry, silver plate and gold and silver bullion stored with the Safe Deposit Company; examine, appraise and guarantee the value of goods represented by such receipts; accept foreign drafts accompanied by bill of lading for stones for import; assume active trusts with respect to estates comprised in considerable part of jewels. It will be, by reason of the experience and connection of jewelers upon its directorate, particularly well adapted to render assistance to the jewelry trade by way of loans. It will be the natural channel for the promotion and financing of all new enterprises in the jewelry trade. Its building will offer the best facilities for a jewelers' exchange, should that contemplated project be carried through. It will become, in short, the recognized financial headquarters for that trade.

Between \$75,000,000 and \$100,000,000 capital is represented by the jewelry houses centering in the Maiden Lane district. This Trust Company is devised primarily to furnish such adequate financial facilities to that important business as it enjoys in Paris and Amsterdam. The plan has met with practically unanimous approval from the trade and hearty support in deposits and business has been promised from all departments. The specialty which, depending principally for its success upon the representative character and reputation of the experts upon its list of directors, will be a virtual monopoly; will, it is confidently believed, furnish a steady and lucrative business from the start, to which will be added such sources of profit as are open to all trust companies.

The stock will be first offered to those identified with the diamond, jewelry and silver ware trades. The balance unsubscribed will then be thrown open to the public.

The Safe Deposit Company will rent safes and store valuables in the usual manner, and will be equipped with every modern device, insuring absolute safety and convenience to its patrons. An important novelty will be a secondary vault, which will be kept open day and night seven days in the week the year through for the convenience of those patrons who, for one reason or another, find themselves in charge, after business hours, of jewelry, securities or other valuables which it would be unsafe to leave at large. Special safes in this vault will be rented by the day, week or year.

The Safe Deposit Company will make a specialty of receiving upon storage and insuring stones, jewelry, plate, bullion, works of art, etc., giving, where desired, negotiable warehouse receipts therefor. The president of the company will be a thorough expert, and all goods will be examined by him, assisted in important cases by a committee of experts from his directors.

The Trust Company will have from 20 to 24 directors; the Safe Deposit Company six or eight. In each about half will be leading jewelers; the remainder are to be chosen from among bankers and capitalists.

HEADQUARTERS FOR

# Railroad Watches

WE ARE THE LARGEST DISTRIBUTORS OF

# Dueber-Hampden Watches

IN NEW YORK.

WRITE FOR QUOTATIONS.



*John W. Sherwood & Co.*  
 Watches. Chains. Diamonds. Jewelry.

No. 3 MAIDEN LANE,

NEW YORK.

Hand-Made Gold Cases a Specialty.

# THE DUEBER HERALD

THE ADVOCATE OF HONEST BUSINESS METHODS.  
✻ DEVOTED TO THE RETAIL JEWELRY TRADE. ✻

VOL. I.

CANTON, OHIO, NOVEMBER, 1899.

No. 7.

## "EXPLANATORY."

A merchant once overdrew his bank account.

\* \* \*

On the following day he called upon the cashier of the bank and gave him a plausible explanation of how it happened.

\* \* \*

"Your explanation sounds reasonable," said the cashier, "but, Mr. Man, what we want are the accounts that never require explanation. There's a debit and a credit side. Accounts ought to explain themselves."

\* \* \*

Watches, like bank accounts, ought never to require "explanations." A watch is made to show the time of day. If it discharges this duty faithfully and accurately, what need of "explanation?"

\* \* \*

The Dueber-Hampden watch, like the properly conducted bank account, explains itself. The movement is made TO KEEP TIME; the case, to protect the movement, to be an ornament and to contain the exact amount of precious metal paid for.

\* \* \*

The Dueber-Hampden watch has no peer. It is the proudest achievement of America's watch industry.

## THE WATCH AND PUBLIC SAFETY.

One inaccurate watch can cause more railway accidents than all the block systems in the world can prevent.

We have before us the records of two fatal railway accidents, both of which were caused by inaccurate watches,—watches fitted with devices that were unsafe, though undoubtedly accompanied by lucid and interesting "explanations."

Notwithstanding these facts, many railroad managers permit themselves to be "explained" into entrusting the watch inspection on their roads to incompetent, and, moreover, interested persons, who do not shrink from "explaining" new watches upon the employes for no other reason than to force the sale of a "new" movement, supplied with "new" inventions, duly "explained."

Such procedure is manifestly wrong.

Let the retail jeweler enlighten the public and the public will have an opportunity of enlightening the managers of railroads.

Elmira, N. Y.

Have carried my 17-jewel Dueber-Hampden watch for three years. Would not change it for any on the road. It has not varied over a half minute in months, in fact, it is always right.

EUGENE H. RIBBLE, Engineer,  
N. Central R. R.

## A QUESTION AND SOME FACTS.

There are men who would "kick" if you sold them a gold dollar for 95 cents.

\* \* \*

Of these, the least said, the better. We would like to ask you a question about the other kind; the kind who come into your store, buy a good article, and, if wholly satisfied with it, have the manhood to tell you so.

\* \* \*

Have you ever met one of that kind who, after buying a Dueber watch case, came to you and said: "This case is not as represented. I'm dissatisfied?"

\* \* \*

The one glaring peculiarity of Dueber watch cases is that they are exactly as represented. If you sell one, you are sure of a satisfied customer.

\* \* \*

We heard of a retail jeweler once who said that to sell a gold-filled watch case was like "skating on thin ice." Poor, misguided man! He didn't sell Dueber's.

\* \* \*

The Dueber mark on cases is like the Hall-mark of England on silver.



**A. & B.**

**HEADQUARTERS**

FOR

**Waltham Watches**

EVERY GRADE.

**AVERY & BROWN,**

68 Nassau St., New York.

**JUNK-SHOP METHODS.** The time is not far distant when a jeweler will demand different methods than are now employed by some salesmen in disposing of their stock. How any jeweler with any reputation will allow an auctioneer to run in a lot of inferior goods and sell them on his reputation, using his store for a junk-shop to dispose of the auctioneer's goods, not his, is a hard problem to solve.

**E. J. GREGORY, Jewelers' Auctioneer,**  
Jewelers' Building, Boston, Mass.

DON'T FORGET THE JEWELERS' CIRCULAR PUBLISHING CO.'S BOOK LIST when in want of any technical work in the Jewelry or Kindred Trades.

**Death of Charles Bosch.**

PHILADELPHIA, Pa., Oct. 25.—Charles Bosch, a retired jeweler and watchmaker, at one time well known in the local trade, died suddenly to-day at the home of his nephew, Otto Schymik, on W. Huntingdon St. Mr. Bosch was born in Wurtemberg, Germany, Jan. 17, 1818. After learning the trade of watchmaking he emigrated to America, locating in this city. Here he carried on the jewelry and watchmaking business for more than 50 years at 3d and Brown Sts. He retired from business seven years ago. He never married.

At an inquest held by the coroner it was in evidence that the venerable jeweler died of heart disease.

**Settlement in the Failure of L. A. Scherr & Co.**

PHILADELPHIA, Pa., Oct. 27.—A meeting of the creditors of the bankrupt firm of L. A. Scherr & Co. was held Thursday before the referee, Theodore W. Elting, and a proposition to pay immediately 25 cents on the dollar was accepted.

The creditors were assured that they would receive 15 per cent additional in a short time and that ultimately they will get all told 50 cents on the dollar.

C. W. Wingate, a former jeweler of Burlington, Vt., and for several years in business in Newburyport, Mass., has leased a store at 16 Bromfield St., Boston, Mass., and will open a jewelry and silver ware store there about Nov. 1.

**Combination of Large Brass Companies Forming.**

WATERBURY, Conn., Oct. 25.—A movement is now well under way looking to the pooling of the interests of the Waterbury Brass Co., this city; the Coe Brass Mfg. Co., operating mills in Torrington and Ansonia, and the Ansonia Brass and Copper Co. These three large concerns are to be consolidated under one general management, each corporation, however, remaining in many respects under the control of its own board of directors, as at present. Nearly all the stockholders of these companies have consented to this plan.

The details of the plan have not yet been made public, but ex-State Senator Charles F. Brooker, of Ansonia, head of the Coe company, will be the manager of the combined companies. It is thought that the central office of the combination will be in Waterbury. It is understood that the promoters of the combination are endeavoring to secure the charter of the American Brass Co., or Brass Trust as it is commonly called, in order to secure the advantages of organization under it. When the charter of the American Brass Co. was renewed at the last session of the Legislature it was understood that this combination would be brought about under that charter eventually, but how soon no one at that time could tell. The charter had been obtained from a previous Legislature.

L. C. Kising, Osborne, Kan., has been purchasing real estate valued at \$400.

**"OMEGA" WATCHES.**

NONE BETTER MADE. OVER 1,000,000 IN USE.

We want ALL LEADING Jewelers to know that the "OMEGAS" are the best watches for you to handle.

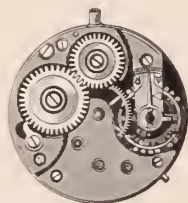

FINE ANCHOR MOVEMENT, 10 LIGNE, FULL JEWELLED—FITTED IN 14 AND 18K. O. F. CASES, SMOOTH AND FANCY ENAMELED CASES. GOOD SELLERS FOR FINE TRADE.

SEND FOR PRICE-LIST.



Pendant Set, 12, 14 and 16 Size. Made in Gun Metal, Silver, Gold Filled and Solid Gold Cases.

BECAUSE—They are ACCURATE timepieces.  
BECAUSE—They are SOLD only to the TRADE.  
BECAUSE—They give SATISFACTION to your CUSTOMERS.  
BECAUSE—They are PROFITABLE, as no prices are advertised in any journal.

The "OMEGAS" are Pendant Set, fit 0, 12 and 16 size Waltham cases, and are made in 6 different grades, as follows:

7 Jewels, Expansion Balance, Double Roller, Nickelized.

15 Jewels, Expansion Balance, Double Roller, Nickelized.

15 Jewels, Expansion Balance, Double Roller, Nickel, Pat. Reg.

17 Jewels, Expansion Balance, Double Roller, Nickel, Pat. Reg., adjusted.

17 Jewels, Expansion Balance, Double Roller, Nickel, adjusted to 5 positions.

21 Jewels, Expansion Balance, Double Roller, Nickel, adjusted to 5 positions.



Pendant Set, 0 Size. WITH SECOND HAND.

Warranted Fine Timepieces. ALL PARTS INTERCHANGEABLE Above made to order with dealer's name if desired.

E. E. ROBERT, 3 Maiden Lane, New York; CROSS & BEGUELIN, 17 Maiden Lane, New York, Selling Agents.

# "Queen Mab"

our new "0 size" watch, is now ready.

It is another practical demonstration of the Duplex Escapement, by the use of which, with our system of movement train, we produce smaller, thinner watches that are reliable than is possible with the lever escapement.

The "Queen Mab" is just what the dealer demands—a watch that is accurate at a price that is popular—a watch that will command purchasers. We



*Sterling Silver Open-Face.*

eliminate hand-work to such an extent that the watches are accurately, uniformly and very economically made. All

the parts, including the escapement, are tool-made and perfectly interchangeable.

The casings are the latest productions of the Keystone Watch Case Co., in 14k. gold-filled, 10k. ten-year "Cyclone," and Sterling Silver—open-face or hunting case. These are supplemented by a handsome line of our own make of open-face, snap-joint cases, in 10k. gold-filled and Sterling Silver.

*The devices for smooth winding pendant, hand-set patent regulator and latest method of hairspring adjustment are all points that will be appreciated by the initiated and seen to advantage in the "Queen Mab."*

Order now for future delivery.  
**THE NEW ENGLAND WATCH CO.**  
 WATERBURY, CONN.



*Movement.*

## The Leader

...IN...  
 HIGH GRADE  
 WATCHES

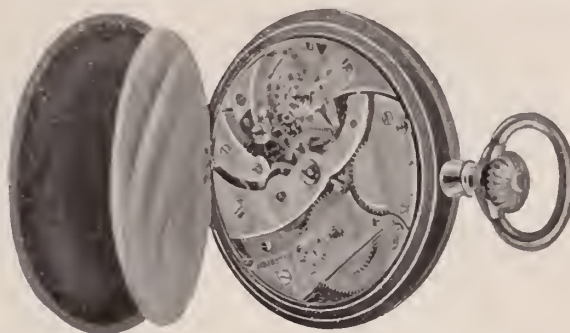

## VACHERON & CONSTANTIN,

GENEVA, SWITZERLAND.

FIRST in { Quality, Adjustment, Durability, Style.



TRADE-MARK.

FITS ALL SIZES OF AMERICAN CASES.

{ NEW GRADES SIZES IMPROVEMENTS.

{ SPECIAL GRADES FOR RAILROAD MEN.

**EDMOND E. ROBERT,** 3 Maiden Lane,

SOLE AGENT,

**New York.**

## Our Hand-made Cases

are constructed in the old reliable way, which is a pride to the Manufacturer, Dealer and Wearer.

STAMPED.



18 K.

ALL CASES BEARING THIS MARK, ARE HAND-MADE.

STAMPED.



14 K.

Manufactured by **DUBOIS WATCH CASE CO.,**  
 Makers of **SOLID GOLD CASES.**

21 and 23 Maiden Lane, New York.



**Plated Seamless Wire and Aluminum Solder.**

144 PINE ST., PROVIDENCE, R. I.

### The Jewelers' Strike Off.

The Leaders of the Strike of New York Journeymen Jewelers Declare the Strike Off and the Men Return to Their Benches Under the Old Conditions.

The strike of the journeymen jewelers in the trade of New York ended Monday, the men, with few if any exceptions, returning to work at their old places.

The strike was ended without a compromise or without any understanding between the manufacturers and the journeymen, and was declared off at a meeting of the Jewelers' Protective Union (the journeymen jewelers' organization) held Saturday night. During the week the strikers, in many cases, continued to slip back to work with their old employers, and it be-

came evident during the latter part of the week that the fight had almost come to an end. On Saturday afternoon Grand Secretary Frank Morrison, of the American Federation of Labor, together with Secretary Koeppicus, of the Jewelers' Protective Union, Secretary Robinson, of the Garment Makers' Union, and a member of the executive committee of the strikers' association, called upon David Kaiser, chairman of the board of directors of the Manufacturing Jewelers' Association. Mr. Morrison asked Chairman Kaiser if he would call a meeting of the directors of the Manufacturing Jewelers' Association and have a conference with the view of arriving at a basis of compromise. This request was absolutely and emphatically refused, Mr. Kaiser claiming that under no

circumstances would the Manufacturing Jewelers' Association recognize the union in any way.

After a talk of nearly two hours Mr. Morrison left, and later had a conference with the members of the Jewelers' Protective Union. At a meeting of the union held that evening the strike was declared off. All the men who have gone back to work have resumed their old positions in the old shops and continue as before the strike began.

Secretary Koeppicus, of the Jewelers' Protective Union, was seen yesterday morning by a CIRCULAR reporter, at the factory of Wm. Scheer, 45th St. and Fifth Ave., and said: "Yes, the strike is over. It was declared off Saturday night at a meeting of the union and after we had held a conference with Secretary Morrison, of the American Federation of Labor, and others. We will now go ahead and strengthen the organization. All the men, so far as I know, have gone back to work in their old places."

## Another Victor.

When the crucial test comes, when quality tells, side by side with the conquerors Concord and Raleigh stands

### THE BOSTON.



O size, 3 rows of pearls, made in Montauk, 20 years' guarantee, and 14 F.K., 25 years' guarantee.

**Joseph Fahys & Co.,**

Established 1857.

FAHYS BUILDING, NEW YORK.

#### NO AGITATION AMONG THE PROVIDENCE WORKING JEWELERS.

PROVIDENCE, R. I., Oct. 28.—But little is now heard of the agitation which some professional labor agitators have endeavored to create among the working jewelers. Their organization has been practically completed, it is understood, but the manufacturers have encountered nothing as yet which would tend to show that the union is to be detrimental in any way to their interests. There has been no move on the part of the manufacturers toward organization.

#### NEWARK JEWELERS' UNION ELECT OFFICERS.

NEWARK, N. J., Oct. 25.—At the regular weekly meeting of the Jewelers' Protective Union of Newark, held last night, these officers were elected for the ensuing year: President, Thomas Allsopp; vice-president, Felix Deman; recording secretary, Charles Stadler; financial secretary, Walter Thurner; treasurer, Edward Daniels; sergeant-at-arms, Walter Bridgens; trustees, William Taylor, Charles Moore and William Van Riper; auditors, Joseph Crane, Edward Baug and Frederick Beachknow.

#### Trans-Atlantic Voyagers.

##### TO EUROPE.

Wm. Hoffman, with Eichberg & Co., New York, sailed yesterday on the *Kaiser Wilhelm der Grosse*.

Alvin L. Strasburger, of Louis Strasburger's Son & Co., New York, sails Saturday on the *Campania*.

##### FROM EUROPE.

H. W. Phelps, of the Merrick, Walsh & Phelps Jewelry Co., St. Louis, Mo., returned last week on the *Kaiser Wilhelm der Grosse*.

Hattie Helfrich, the 17-year-old daughter of jeweler A. Helfrich, Green Bay, Wis., dropped dead from heart failure at noon Oct. 24. She had been to school and had just returned to her home.

# A. WITTNAUER,

MANUFACTURER OF

## THE CELEBRATED

# Longines and Agassiz Watches,



9-11-13  
MAIDEN LANE,  
NEW YORK.



AGASSIZ MOVEMENT  
1899 MODEL.

WHICH HAVE BEEN  
SOLD TO THE LEAD-  
ING JEWELERS OF  
THE WORLD DUR-  
ING THE PAST

## 53 YEARS.



CASE  
1899 MODEL.

WE HAVE A COMPLETE VARIETY OF

## Decorated Watches for the Holiday Trade.

9-11-13 Maiden Lane,      New York.

Geneva Office, 16 Rue du Mont Blanc.

## The Leading Low=Priced

American timekeeper is our new No. 7, 18 size, seven-jeweled movement. Carefully inspected and run before shipment.

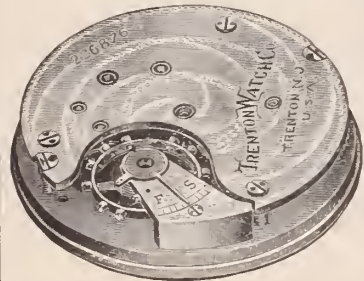

Trenton, 18 Size, No. 7, 7 Jewels,  
Stem-Winding, Lever-Setting Open  
Face and Hunting.

The No. 7 contains a brass and steel composition balance of a better quality than any other movement of like price.

No. 8 in gilt finish.

SEND FOR PRICE-LIST.

**The Trenton Watch Co.,**  
Trenton, N. J.

### The Philadelphia College of Horology

We teach thoroughly

Watchmaking, Engraving,  
Jewelry Work and Optics.

Young Men, Don't be Half Jewelers

when we can make a thorough workman of you in a short time. Write for our Prospectus, which will give you full information. Now is the time to make application for a good bench for the first of the year.

F. W. SCHULER, Principal,  
1215 Filbert Street, Philadelphia, Pa.

### Federal Grand Jury Ignores the Cases Against the Burlington, Ia., Jewelers.

BURLINGTON, Ia., Oct. 26.—The Federal Grand Jury at Keokuk last week ignored the cases of the Burlington jewelers which caused a sensation a few months ago. It will be remembered that several questionable characters of this city went to various dealers and, by their tales of woe, succeeded in borrowing money upon jewelry they had in their possession. It was afterwards learned that the Federal authorities had instigated this for the purpose of getting evidence against the jewelers to be used in the prosecution for violation of the revenue laws in regard to pawnbroking. Joseph Voelkel, Gus A. Waldin and Henry H. Waldin were the parties inveigled into the trap, and Voelkel settled the case by payment of the license. The Waldins, however, refused to pay and employed an attorney to defend them. The wisdom of their course was made apparent when last week the Grand Jury made its report and ignored the cases against all three of the men. Henry Waldin, it is reported, also paid a fine to escape trouble, but Gus Waldin was determined to fight the case to an end.

### Workman for Wm. B. Durgin Co. Wants \$5,000 Damages for Two Fingers.

CONCORD, N. H., Oct. 27.—The case of W. W. Peabody vs. The Wm. B. Durgin Co., this city, was marked for trial at the Supreme Court last Monday. This case has attracted considerable interest, owing

to the circumstances connected with the injury received by the plaintiff. It seems that while Mr. Peabody was operating a drop machine, which is alleged to have been defective, he lost two fingers on his right hand. The injury was a very severe one and incapacitates Peabody to such an extent that he sues to recover \$5,000 damages. The case went over from the last trial term, and it is understood that lately the defendant company made an overture looking toward a settlement of the matter out of court. The amount of money offered in settlement of the damages was refused by the plaintiff.

### Birmingham, Ala.

J. R. Steele, optician, has located in the Lacy building, Pratt City.

J. Jaffe, Bessemer, has purchased a fine block of Bessemer city property for building purposes.

T. L. Bell, of E. Lowinsohn, was happily married at Eufaula, Ala., on Oct. 27, to Miss Mamie McNeill, of Ozark.

The C. N. Maxwell Jewelry Co., Tuscaloosa, have fitted up a handsome silver service which the Catholic people will present to a popular railroad man of that city. The service is on exhibition in the Maxwell Co.'s window.

Henry J. Rosenstihl has fitted up his optical department in connection with his jewelry store at Union Springs. Mr. Rosenstihl only recently made a trip to New York, where he purchased a full stock for this new departure.



## Our New.... Jewel Case



has been pronounced  
by competent judges  
the best in size, shape,  
workmanship and fit-  
ting, in the market.

**Roy Watch Case Co.,**

Makers of SOLID GOLD CASES,

21 Maiden Lane,

New York.

**ROY**

TRADE-MARK REGISTERED.



**This Is Undoubtedly the Bogus Workman with Bogus Pay Checks.**

BURLINGTON, N. J., Oct. 25.—A stranger entered the drug store of Edgar Sparks on Saturday night and tendered a check in payment for a small article, requesting Mr. Sparks to give him the balance in money. The check was drawn to the order of H. J. Foy for \$13.75 in amount, and signed Geo. W. Groves. Later Mr. Groves denied having issued it. The matter was reported to the authorities, and officers arrested the man at the corner of Broad and High Sts., and escorted him to the Mayor's office. The prisoner returned Mr. Sparks's money to him, and Foy was locked up.

At the time of his arrest Foy carried a small lunch box and had every appearance of a working man just returning from work. He had paid jeweler F. H. Fry a visit earlier in the evening, and his movements in laying down his lunch box, making his purchase of an alarm clock and pulling the check from his pocket and a request for a pen to endorse the check vividly recalled to Mr. Fry an account he had read in THE CIRCULAR of a bogus check worker. Mr. Fry quietly informed the stranger that he was not cashing checks that night. On examining the lunch box after Foy's arrest it was found to contain a number of blank checks of banks in different parts of the country, together with two filled out checks on a Bristol bank for \$12.50 each drawn to the order of H. J. Foy and signed Mullen & Bro., who conduct a plumbing business there.

At a hearing before Squire Smith Foy virtually acknowledged his guilt and was committed to the county jail to await the action of the authorities.

**The Oregon Association of Opticians Permanently Organized.**

PORTLAND, Ore., Oct. 24.—A formal meeting of the Oregon Association of Opticians was held in Assembly Hall, this city, yesterday afternoon. J. O. Watts, of Eugene, was elected president pro tem, and H. S. Butterfield, of Portland, secretary. The purposes for which this association is constituted are the establishment and maintenance of all legitimate optical trade in the State of Oregon, and the interchange and discussion of optical, social and business matters. A permanent organization will be effected to-day.

**Importations at the Port of New York.**

*Weeks Ended Oct. 28, 1898, and Oct. 27, 1899.*

China, Glass and Earthen Ware:	1898.	1899.
China .....	\$75,584	\$86,037
Earthen ware.....	25,117	18,754
Glass ware .....	17,123	26,868
Optical glass .....	not recorded	2,639
Instruments:		
Musical .....	27,196	10,949
Optical .....	10,951	11,167
Philosophical .....	1,900	992
Jewelry, etc.:		
Jewelry.....	8,661	11,013
Precious stones .....	295,019	222,629
Watches .....	14,509	21,421
Metals, etc.:		
Bronzes .....	2,017	2,911
Cutlery .....	12,749	30,742
Dutch metal .....	613	2,023
Platina .....	20,791	59,901
Plated ware .....	2,112	404
Silver ware .....	1,010	1,966
Miscellaneous:		
Alabaster ornaments .....	647	1,874
Amber .....	640	....
Beads .....	3,573	3,148
Clocks .....	5,842	7,386
Fans .....	8,767	4,311
Fancy goods .....	4,447	8,038
Ivory .....	3,416	15,563
Ivory, manufactures of.....	639	749
Marble, manufactures of.....	19,205	16,178
Statuary .....	2,106	4,345

**Jewelers' Gold Bars Withdrawn and Exchanged at New York.**

*Week ended Oct. 28, 1899.*

The U. S. Assay Office report:

Gold bars exchanged for gold coin.....	\$227,147.79
Gold bars paid depositors.....	180,593.50
Total .....	\$407,741.29

Of this the gold bars exchanged for gold coin is reported by the Sub-Treasury as follows:

Oct. 23 .....	\$47,849
Oct. 24 .....	48,197
Oct. 25 .....	27,608
Oct. 26 .....	36,540
Oct. 27 .....	26,186
Oct. 28 .....	....
Total .....	\$186,380

**Petition Filed to Put J. Mednikow into Bankruptcy.**

CHICAGO, Ill., Oct. 27.—A petition has been filed in Milwaukee, Wis., to put J. Mednikow, of that city, into bankruptcy. As reported in THE CIRCULAR at the time, Mr. Mednikow came to this city last June to endeavor to secure an extension of his accounts with his Chicago creditors. In most cases he was successful, but some of the creditors sued him for the amounts of their bills and got judgments, which still stand against him.

**Emblems,  
Monograms,  
Special  
Designs,**

anything that is "engravable" you can have engraved to order, to execute any special order, on one or more of Bell Gold-Filled Watch Cases.



To get the story of "Aid in the Sale of Bell Cases," write.

**Buy of the Maker.**

**THE BELL WATCH  
CASE CO.,**

**CINCINNATI, OHIO.**

CATSEYES	SAPPHIRES	DIAMONDS	RUBIES	EMERALDS	PEARLS	PEARL NECKS	PEARL ROPES	
OLIVINES	<p><b>PEARLS, DRILLED AND UNDRILLED.</b></p> <p><b>PEARL ROPES, NECKS and COLLARETTES.</b></p> <p><b>We are buyers of American Pearls.</b></p>							Pearl Collarettes, mounted with Diamond Bars.
OPALS	<p>LONDON: 19-20 Holborn Viaduct. <b>JOSEPH FRANKEL'S SONS,</b> 68 Nassau Street, NEW YORK.</p> <p>TELEPHONE, 3899 CORTLANDT.</p>							
SCIENTIFIC RUBIES	<p><b>FANCY COLORED DIAMONDS and GEMS in PEARLS and PRECIOUS STONES.</b></p>							

**DIAMONDS.**  
**Wm. S. Hedges & Co.,**  
 IMPORTERS OF  
**Diamonds and Precious Stones.**  
**DIAMOND JEWELRY.**  
**170 Broadway, New York.**  
 26 Holborn Viaduct, London.

## SCHULZ & RUDOLPH,

....Importers and Cutters of....

**..DIAMONDS..** .....AND OTHER....  
**PRECIOUS STONES.**

SOLE AGENTS FOR THE CELEBRATED

**JULES JÜRGENSEN WATCHES AND**  
**COPENHAGEN, CHRONOMETERS.**

**28 John and 65 Nassau St., New York.**

**MOUNT & WOODHULL,** FORMERLY WITH LATE FIRM OF  
 RANDEL, BAREMORE & BILLINGS,  
 .... IMPORTERS OF ....

**Diamonds, Other Precious Stones, Pearls, Etc.,**  
**Makers of fine DIAMOND JEWELRY,**

**26 MAIDEN LANE (SOUTHWEST CORNER**  
**NASSAU STREET), NEW YORK.**

JOHN C. MOUNT.

ADDISON W. WOODHULL.

**FOX & CO., Lapidaries** and  
 importers  
 of  
**....Precious Stones.**

Now at.....

**22 JOHN STREET,**  
**NEW YORK.**

Cutters of American Gems and Fine Miniature Glasses  
 Fine Stone Seal Engraving  
 (Crests, Monograms, etc.), a Specialty.

## The Bowden Rings

ARE COMPLETE IN VARIETY, CORRECT  
 IN QUALITY AND PERFECT IN FINISH.  
 WE MAKE EVERY VARIETY OF FINGER  
 RINGS

**J. B. BOWDEN & Co.,**

**1 MAIDEN LANE,**

**NEW YORK.**

### Precious Stones: London Market

HATTON GARDEN, London, Eng.,

Oct. 21, 1899.

*The Diamond Market:* Reviewing the position generally it may be said that the consensus of opinion amongst old market hands is that the supposed scarcity of stuff is only superficial. Supplies from Kimberley and Jagersfontein are, of course, entirely stopped, but large consignments were made before war commenced. A considerable quantity of diamond goods is also locked up in Paris, in preparation for the Exhibition, which will be unloaded at the end of the show. In fact, Parisian houses are even now offering goods for sale on the condition that delivery is put forward to the close of the Exhibition.

Advices from the continental diamond markets are in accordance with the state of affairs here. The Central News Amsterdam correspondent telegraphs: "Owing to the war in South Africa crude diamonds have advanced to such a high price that merchants are refraining from buying them. Consequently, the diamond polishing firms are preparing to close their premises, and hundreds of skilled workmen will be thrown out of employment."

American buyers report continued difficulty in filling orders for fine colored stones in all the first-class descriptions.

R. F.

### DeBeers Versus Calumet & Hecla.

[London Iron and Coal Trade Review.]

**L**AST year the Calumet & Hecla was the largest dividend payer among the American mining companies, the total amount handed over to its shareholders last year having been £1,400,000. It is, however, exceeded by the DeBeers Consolidated Mines, which paid last year a total of £1,537,460. In addition to this, the DeBeers Co. paid during the year £172,500 as interest on its debentures, and £128,480 for retiring a portion of its bonded debt, making a total of £300,980, and brings up the total payments in the nature of profits to £1,838,440. The proportion of profits to the capital stock of the DeBeers Co., however, was only 40 per cent, while that of the Calumet & Hecla was 280 per cent. It must be remembered, however, that the capital stock of the latter company is nominally very small.

The DeBeers Co. is the wealthiest mining corporation in existence. In 1898 its production in diamonds reached nearly 2,500,000 karats, valued at £3,650,000. The displacement of blue on the floors amounted to over 3,450,000 loads of 16 cubic feet, which quantity was washed for a yield of 0.80 karats per load, while the number of loads hauled from the mine were probably a little in excess of this, in accordance with usual practice. In addition to the huge quantity which is annually treated, the company has a reserve on its floors of no less than 2,892,000 loads, which is valued at 21s. 2d. per load. The average value of the diamonds is 26s. 6d. per karat, and will probably be higher during the current year. The monthly expenses aggregate nearly £160,000, out of which over £100,000 is paid in wages.

**The Defence of Kimberley.**

[London Telegraph, Oct. 17.]

AS to the safety of Kimberley—though the anxiety felt in regard to Mafeking, which is in an admittedly perilous position, is greater—there will be much apprehension entertained for a week or ten days; and probably fears both for the person of Mr. Rhodes and the property of the mining companies will not be wholly removed until a relief column has arrived and driven back the invaders. The expectation is that some weeks must elapse before the troops and batteries from England can be on the spot. In the meantime, the information as to the actual defences of Kimberley has not been brought down to date, owing to the military censorship. A fortnight ago Kimberley had 2,700 men fully armed, including volunteers and regulars, and these forces had nine Maxim guns and twelve field guns. The regulars were the North Lancashire Regiment, but a detachment has since been forwarded to Mafeking. The volunteers are mostly in the employ of the De Beers, and are fine fellows. The town guard, which have been mobilized, are also well armed and form a serviceable body. Before telegraphic communication ceased it was known in the city that the military authorities had thrown up earthworks, protected the sanatorium, where Mr. Rhodes is staying, with sandbags, and crowned the heaps of rubbish from the mines with guns. These heaps are 60 feet high, and, as they rise from the veldt, which is totally flat for miles around, they command wide ranges. In addition, the risk of night surprise is minimized by the use of the most powerful electric searchlights in existence. People who know the Boers' ways are persuaded that they will not attack the entrenched position.

Will Kimberley be able to withstand a prolonged siege? The hope is expressed that, having anticipated what was coming, the town has been well stored with provisions. There has been no rush of refugees from the place, and the present population is estimated not to exceed 20,000 people. In normal times it has been fed by railway, and largely drew its supplies from the Orange Free State. It has no resources of its own, nor is it surrounded by farms which might yield provender to successful sortie parties. The beleaguered are at a similar disadvantage, and should they be wanting in commissariat they must depend upon biltong, or sun-dried flesh, with meal, the usual fare of the Boer when in the saddle, for the game has long since disappeared from the district, and the rinderpest carried off all the cattle.

**Parke M. Childress Has \$8,465.16 Liabilities Against \$25 Assets.**

SAVANNAH, Ga., Oct. 27.—Parke M. Childress, jeweler and optician, of Valdosta, filed a petition in bankruptcy in the United States Court Oct. 24. The appended schedules show liabilities of \$8,465.16, and assets of \$25. These latter the bankrupt desires reserved to him, as a homestead for the support and maintenance of his family.

ESTABLISHED 1840.

**Chester Billings & Son,**

Successors to **RANDEL, BAREMORE & BILLINGS,**

IMPORTERS OF

1840 RANDEL & BAREMORE.  
1866 RANDEL, BAREMORE & CO.  
1880 RANDEL, BAREMORE & BILLINGS.

**DIAMONDS**

OTHER PRECIOUS STONES AND PEARLS.

58 Nassau Street,  
29 Maiden Lane, 22 Holborn Viaduct,  
NEW YORK. LONDON, E. C.

DIAMOND JEWELRY.

**Pearl Purchasers**

will find it to their advantage to inspect the stock of

**Fred. W. Lewis & Co.,**

the largest on this side of the Atlantic.

No. 1 MAIDEN LANE (Cushman Building), NEW YORK.

**Oppenheimer Bros. & Veith,**

Importers and Cutters of

Dealers in

**Diamonds**

**Watches,**

**Cor. Nassau and John Streets,**

(PRESCOTT BUILDING.)

....New York....

Amsterdam,  
2 Tulp Straat.

London,  
45 Holborn Viaduct.

**John F. Saunders,** Cutter and Importer of

**DIAMONDS** AND OTHER PRECIOUS STONES.

FINE PEARLS A SPECIALTY.

68 Nassau St., cor. John St., Sheldon Building, Room 16, NEW YORK.

RUBIES.

SAPPHIRES.

**C. G. MALLIET & CO.,**

EMERALDS.

14 MAIDEN LANE, N. Y.

DIAMONDS.

## PEARLS.

## Profitable Goods.

Our stock of Pearls and Precious Stones is made up of profitable goods—profitable to the dealer as well as to ourselves. They are purchased by us with a view of satisfying the dealer completely; an obligation of which we are ever careful. Hence, our customers receive complete value, dollar for dollar.

## Alfred H. Smith & Co.,

182 Broadway, N. Y.  
CHICAGO. LONDON.

## DIAMONDS

And Other Precious Stones.

## "The Pearl House."

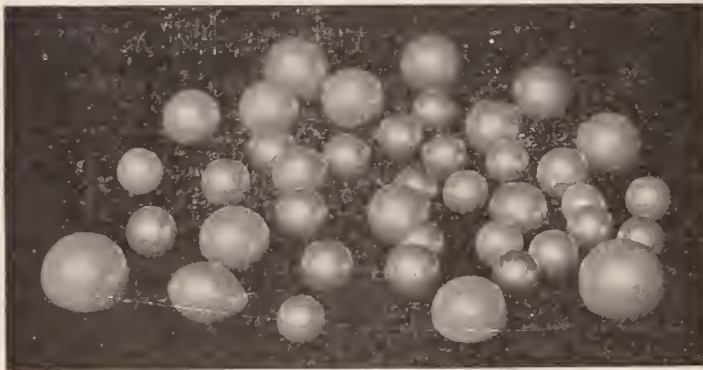

PEARLS PHOTOGRAPHED EXACT SIZE.

Our recent shipments of Pearls are worthy of most careful consideration. We have no salesmen; call or drop us a line.

## Eisenmann Bros.,

Importers of Pearls and Precious Stones,

21 and 23 Maiden Lane, = = NEW YORK.

Paris: 3 Rue Saint Georges.

### The Career of the Late Phillippe Auguste Weiss.

Fuller details are at hand of the career of Phillippe Auguste Weiss, whose death occurred in Switzerland, Sept. 22 and was reported in THE CIRCULAR of Sept. 27. The deceased was for many years one of the heads of the watch manufacturing house of Vacheron & Constantin, Limited, and acted in the capacity of commercial or general manager for the concern, occupying this position until his illness caused him to resign. His activity and extraordinary ability in his line were well known to the watch trade, and, although he never learned the trade and could not be considered a practical watchmaker, he was nevertheless looked upon as one of the pillars of the business, and did much to advance the interest of watchmaking in Switzerland. In the commercial world in his country the deceased occupied a most prominent position, and among other things was a member of the Swiss Chamber of Commerce for a number of years, and also of the chambers of commerce both of Geneva and Zurich. Owing to his recognized ability on commercial lines, he did much work for his Government, among other things preparing several commercial treaties, of which the principal was the one between France and Switzerland in 1883.

Mr. Weiss was a member of the executive committee of the Geneva Exposition of 1896, and was made a member of the committee representing Switzerland at the Paris Exposition of 1900. From this last position his illness forced him to resign shortly before his death. Besides helping to improve the watchmaking trade of his country the deceased did other work of interest to the jewelry craft in general, prominent in which was his activity in obtaining the Swiss gold and silver stamping law.

### B. & W. B. Smith File a Petition in Bankruptcy.

Jacob W. and W. B. Smith, manufacturers of jewelers' office furniture and fixtures, 220 W. 29th St., New York, filed a petition in bankruptcy in the United States District Court yesterday.

As already told in THE CIRCULAR, the business, which was conducted under the style of B. & W. B. Smith, had come into the hands of the Sheriff under certain executions issued by creditors. According to the schedules filed with the bankruptcy petition, the liabilities are \$82,925.21, and the assets \$76,431. Of the latter the value of the stock is placed at \$11,110, the machinery and tools at the firm's factories in New York and Flushing at \$13,021, and the debts due to them at \$2,000. Their interest in real estate is estimated at \$40,000.

Goldberg Bros., Cincinnati, O., are rushed with orders for their patent metal novelty show case, a gold finished fixture which they are giving away with every order for their guaranteed 5 and 10 cent collar buttons. They are also giving away with link sleeve button orders their novelty, the "statue man" show case, an admirable attraction.

**Death of Theodore Schrader.**

CHICAGO, Ill., Oct. 30.—Theodore Schrader, head of the firm of Theo. Schrader & Co., this city, died at 2.30 o'clock A. M. today, at Agustana Hospital, after an illness of over a week from a complication of stomach troubles with which he had been afflicted for many years.

Mr. Schrader was born in Rodenberg, Germany, in 1849. He came to this country when a boy and located in Chicago. After attending the public schools, he went to work for his uncle, Matthei Schrader, who founded the present firm in 1863. When Matthei Schrader died, Theodore succeeded to the business and continued it in his name. In 1893 A. H. Wittstein was admitted to the firm, and Chas. L. Wittstein, in 1896, was also admitted.

Up to the time of his death Mr. Schrader had been active in the management of his business, as far as his health would permit. During the last six months he had charge of the firm's factory at Kinsey St. and Dearborn Ave. He was a member of the Chicago Jewelers' Association, which called a special meeting for Tuesday morning to take action upon his death. Mr. Schrader was thoroughly honest, upright and well beloved. He was a thorough mechanic, having worked in all the various departments of his factory.

The funeral will take place Wednesday at 2 o'clock P. M. from the family residence, 73 Maple St.

**Mrs. Ellis Accuses Jeweler W. A. England of Assault.**

WORCESTER, Mass., Oct. 26.—Nettie C. Ellis has entered a complaint of assault against W. A. England, jeweler. On the day of the alleged assault Mr. England entered a complaint of attempted blackmail against Mrs. Ellis, saying that when he had taken her to the second floor to show her some clocks she demanded of him a check for \$5,000 or she would accuse him of attempted assault. She was taken to the city hospital at the time.

Geo. C. Clapp recently succeeded Samuel A. Christie, South Acton, Mass.

OTTO K. TREIBS.

PAUL E. TREIBS.

**TREIBS BROS.,**

68 Nassau St.,

New York.

CUTTERS AND IMPORTERS OF

**Opals.**

F. E. TREIBS,

Oberstein,

Germany.

ESTABLISHED 1842.

HERMANN TREIBS.

ALBERT TREIBS.

EMIL TREIBS.

**The  
Constant  
Advances**

in the price of Diamonds should warn the live dealer to "take the bull by the horns"—to buy before prices advance still farther. Our Mr. Rees, just returned from Europe, has made extensive purchases for our customers' benefit.

**ZIMMERN, REES & CO.,**

Gill Building,

9-13 Maiden Lane, New York.



**One Glance**

at our Diamond Jewelry always convinces the shrewd Jeweler of the advantage of handling it.

Every piece is made to sell, and Christmas Eve rarely finds a piece of our make in the Jeweler's stock.

PROSPERITY—1899—DIAMOND JEWELRY.

*Kohn & Co*  
9.11.13 MAIDEN LANE.  
NEW YORK.

### Providence.

H. A. Fink, representing David Marx, New York, was in town last week.

Mr. Phillips, of Phillips & Richter, Cincinnati, O., was in town Monday.

J. W. Capron, formerly salesman for Linton & Co., is now with J. J. White.

Cutler & Massell may now be found at 125 Eddy St., having removed there from 220 Eddy St.

Fritz Kraus, formerly with George W. Dover, is now representing Thomas Lind, jewelers' findings.

R. J. McNair is now making plated jewelry at 220 Eddy St. Mr. McNair was formerly a manufacturer of jewelers' findings.

Horace Remington, of Horace Remington & Son, gold and silver refiners, was renominated as a member of the Board of

Aldermen at a caucus of the Republicans held last Tuesday night.

E. Merle Bixby, at the Bixby Silver Co.'s store, has charge of the rifle practice at the range of the Machine Gun Battery, of which organization he is lieutenant.

W. & S. Blackinton, Manufacturers' building, have just acquired one-third more floor room on another floor in that building and are rapidly nearing the point where they will be able to fill all orders promptly.

On Wednesday, at the Park Place Congregational Church, Pawtucket, William Edgar Dickinson was united in marriage with Miss Lillian Gertrude Smith, of Pawtucket. Mr. Dickinson is employed by the Tilden-Thurber Co., and among the gifts was a gold clock from that company.

Joseph E. Crook & Co., chain makers,

were victimized recently by a young man with whom other manufacturers may have had dealings. It appears that the young man's method is to apply for work to be taken to his home, and after having secured the gold links he forgets to return them. The manufacturers are keeping a 'sharp eye out for the fellow.

The smoker which the Manufacturing Jewelers' Salesmen's Association were to have held is still one of the events to be. There is some business to come up before the organization when the meeting is held, and there has been some difficulty in fixing upon a date when all the officers will be able to be present. It is possible that it may be held during the coming week.

Henry Fletcher, of Fletcher, Burrows & Co., was given a vote of thanks at the Republican caucus held in the Eighth Ward for his faithful services in the City Council for the past two years. Mr. Fletcher was defeated for renomination in one of the warmest caucuses that has been held in the ward for years, his opponent receiving 161 votes to 97 received by Mr. Fletcher.

### The Attleboros.

Harold E. Sweet, salesman for R. F. Simmons & Co., has returned from three weeks on the road.

Nov. 29 has been announced as the date of the wedding of James H. Arthur to Miss Mary, the daughter of Albert A. Bushee, of A. Bushee & Co.

The wedding of Miss Ruth C. Wilmarth to Harvey B. Clap, to which passing attention was called last week, proved the leading society event of the Attleboros for the Fall. G. Percy Clap, R. Curtis Read and Joseph A. Coddling, three young men whose names are known in jewelry circles, acted as ushers. The church wedding was followed by a brilliant reception at the Wilmarth house. Mr. and Mrs. Clap left for a honeymoon tour of the south, and on their return will reside in a beautiful new home on Peck St., Attleboro.

The police hold the opinion that a great crime was narrowly averted in the jewelry district of Attleboro last week. There has been so great a demand for silver for the novelty houses, regular silver houses and other concerns that the usual methods of transportation were extended. Levi Swift, a local expressman, was employed to bring out over the road from Providence large quantities of the commodity in the early evening about three times a week. His load sometimes ran far into the thousands of dollars, and the greatest secrecy was maintained. It chanced, however, that while making his deliveries on his arrival in town Mr. Swift noticed he was followed from shop to shop, and the keenest eye kept on his every motion. For three or four nights the espionage was kept up, and he realized that someone was learning his routine, and the probable quantity of the precious metal he was handling. A climax was reached when he met apparently the same mysterious person in a lonely section of his road out to town. He at once armed himself and his assistant and reported the case to the police. He ceased to carry the silver, but prepared to puncture with lead anyone stopping him on his nightly ride. The visitant has troubled him no more.

## Mounted Diamond

pieces in elegant styles and of excellent workmanship are to be found in our stock; you will need some of them in yours. Make your selection early; it will give you a larger choice.

Send for our book of illustrations; it will help you to make sales.

EMERALDS, RUBIES, OPALS,  
SAPPHIRES, PEARLS,  
TURQUOISES.

## HAYDEN W. WHEELER & Co.,

TWO MAIDEN LANE, N. Y.

50 HOLBORN VIADUCT, LONDON.

Internal revenue inspectors visited the local factories last week to see if the law regarding the stamping of express receipts was rigidly complied with.

Herman T. Regnell, of Regnell, Bigney & Co., as president of the Attleboro Young Men's Christian Association, attended the convention of that organization in Lowell last week.

Alpin Chisholm, North Attleboro, who was taken ill with typhoid fever in Des Moines, Ia., while on a trip in the interest of his firm, the Bugbee & Niles Co., has returned convalescent.

The first machinery is being installed in the immense new Bates factory building, which is nearing completion in the burned district. McRae & Keeler are the enterprising firm who are taking these first steps.

The postponed mortgage sale of the B. S. Freeman group of jewelry factories in Attleboro Falls took place last Tuesday. That is, the day arrived and the formalities were gone through, but a settlement was very quickly and simply made, and Mr. Freeman continues the possessor of the property as before.

Sidney O. Bigney announced that his new jewelry factory would be occupied and in operation by Nov. 1. He could not foresee, however, the impossibility of securing timber and had made no provision for an anxious wait of weeks while his contractor searched the United States for materials to use in the building. With this drawback, however, the structure is nearly finished.

The fifteenth annual banquet of Company C Association, the Attleboro Republican Club, Friday, was a noteworthy event in the party. The faithful from the northern half of Bristol county were served by the manufacturers and employes of Attleboro in royal style. Charles M. Robbins as

president occupied the head of the table. The committee in charge of the affair, acting as reception committee and also as supper committee, included Homer M. Daggett, of the Daggett Jewelry Co.; Robert W. Myers, eastern salesman for the Wendell Mfg. Co., Chicago; Captain Herbert A. Clark, of the Horton & Angell Co.; George A. Monroe, Jr., with the United States Automobile Truck Co., and Percy A. Randall, of THE CIRCULAR. Sidney O. Bigney and Major Everett S. Horton, as representatives of the great business enterprises of the town, were given seats of honor with the invited guests.

**Boston.**

Charles Harwood, of Harwood Bros., is seriously ill with pneumonia, having been confined to his home with the disease for upward of a week.

The case of Freeda Irvine, a customer, against B. Adelberg, jeweler, 1033 Washington St., the latter being charged with retaining a watch left with him to be repaired, has been settled out of court.

Charles W. Davidson, president of Thomas Long Co., is receiving congratulations from many friends on the announcement of his engagement to Miss Harriet A. Willey, of Newtonville. Treasurer Frank F. Davidson, of the same company, is also accepting felicitations due to the arrival of an infant son in his family.

Buyers in town the past week included William Moulton, Newburyport; S. C. McKenney, Bath, Me.; Harvey B. Locke, Amesbury; Mr. Jalbert, of Jalbert & Farrington, Woonsocket, R. I.; E. F. Robinson, Ellsworth, Me.; G. H. Woodbury, Newport; D. W. Kelley, North Troy, N. H.; E. E. Hosmer, Providence, R. I.; H. F. Burgess, Fairfield, Me.; F. L. Ammidon, Gouverneur, N. Y.; F. L. Drew, Lewiston, Me.

The trustees of B. F. Larrabee & Co. have secured the signatures of 330 out of 500 creditors, and over one-half in value of the claims, assenting to the assignment. They have completed the taking of stock and find the assets, so far as cash value is concerned, to be much under the original estimate. The trustees intend within a few days to make a proposition to the creditors under which they shall receive a dividend and permit Mr. Larrabee to continue business under certain conditions. The trustees expect to give a statement to the creditors within a week or 10 days.

**Elmira.**

M. Rothschild is now occupying very neat, new quarters at 128 Water St.

John Bally, of Bally & Son, jewelers, underwent a very difficult operation at Rochester, N. Y., Oct. 28, for his remaining eye. The operation was a perfect success and he has regained his long-lost sight of this member, having been totally blind for over a year.

A meeting of the creditors of James T. Wise, bankrupt jeweler, was again held Oct. 28, before referee R. R. Moss and again adjourned. The Second National Bank of this city, in view of the decision of Referee Moss, published last week in THE CIRCULAR, withdrew its claim to \$3,400, and will present it against the estate of W. H. Longstreet, the endorser of Wise's paper. Longstreet, it will be remembered, was Wise's father-in-law, who committed suicide by cutting his throat with a knife. The next meeting of creditors will occur Saturday, Nov. 4.

The Springfield, Ill., *News* of Oct. 19 says: "A watch factory to compete with the trust is to be started at Rockford." What trust will the new factory compete with?

**NONE BETTER.**

**THE  SOLDER**

Recommended by Manufacturers and Repairers.

Our Solders are not plated, but the natural color of the stock. Gold Solder in 1 dwt. pieces. Silver Solder in 1/4-oz. sheets.

Sold in bulk or in any thickness or width desired. In Low Karat—6, 8, 10, 14 and 20.

**ASK YOUR JOBBER FOR IT.**  
If he does not carry it, write us.

PRICES ON APPLICATION.

MANUFACTURED BY...

**THE LEDOS MFG. CO.,**

32-34 Pearl St., Newark, N. J., U. S. A.



DON'T FORGET THE JEWELERS' CIRCULAR PUBLISHING CO.'S BOOK LIST when in want of any technical work in the Jewelry or Kindred Trades.

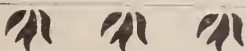

**"GESSOART,"** A Hardened Composition Resembling Terra Cotta.

Water will remove any stains, as the decorations are in oil colors.



Spring. Size, 14 inches high.



Atala. Size, 14 inches high.

**L. W. LEVY & CO.,**  
Successors to Levy, Dreyfus & Co.

NOVELTIES,

194 Broadway, New York.

List Price, per pair, \$5.00.

Discount, 50 per cent.

Send \$2.50 for Sample Pair, boxed.

Reproductions from European Models.

Absolutely Reliable Always

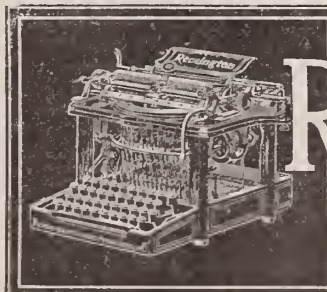

**Remington**  
Typewriter

STANDS THE TEST OF CONSTANT SERVICE

Wyckoff, Seamans & Benedict  
327 Broadway, New York

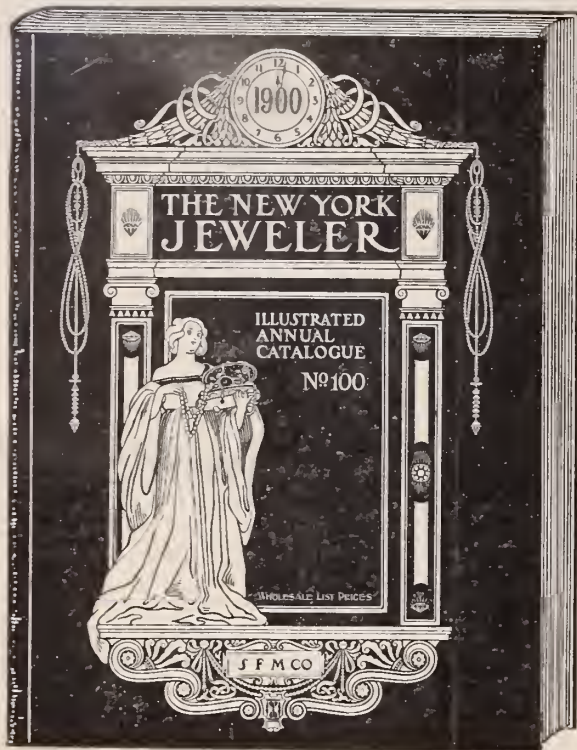

ILLUSTRATION 1-6 SIZE.

**S. F. MYERS CO.,** Manufacturers, Importers  
and Wholesale Jewelers,

MYERS BUILDING, 48 & 50 MAIDEN LANE, 33 & 35 LIBERTY STREET, N. Y.

Address Department No. U 10 when sending for catalogue.

## OUR NEW CATALOGUE

Just out.  
List Prices Only.

724 PAGES, 9 x 13.

For 26 years the acknowledged authority for choice designs in reliable goods and the lowest prices current in the New York market.

WATCHES,  
DIAMONDS,  
JEWELRY,  
OPTICAL GOODS,  
SILVER NOVELTIES,  
MUSICAL MDSE.,

Clocks, Lamps,  
Cut Glass, Silverware,  
Fine Leather Goods  
And Stationery,  
Photographic  
Supplies,  
Jewelers'  
Sundries, Etc.

### San Francisco.

#### TRADE CONDITIONS.

During the past 10 days California has been visited with two substantial rainstorms, which have served to put the trade in a confidential humor as to the coming season. Buyers who were holding off for fear of a dry season are now in the market and business is even better than it has been. The jubilee celebrations of the Odd Fellows, which took place here last week, had a stimulating effect on the retail trade. All the larger stores report an increased volume of business. Wholesalers also benefited, owing to the presence of an unusual number of country retailers.

F. Friedlander, son of William Friedlander, Portland, Ore., is in town visiting the jobbers.

A. Behrend, 129 Montgomery Ave., is preparing to make some extensive improvements in his store.

S. O. Weger, who bought out the jewelry store of O. H. St. John, Fort Bragg, Cal., a short time ago, was in town last week buying stock.

H. E. Hall, of A. I. Hall & Son, has just returned from a trip to Los Angeles, Cal.; here he found business good and everybody rejoicing over the rain.

Charles Wilcoxon, formerly of Marysville, Cal., has obtained a position with the Baldwin Jewelry Co., this city. He has moved his family to this place.

Mrs. E. Lewin, of Shasta, Cal., dropped dead on the street in San Francisco one day last week. She was a widow of E. Lewin, the pioneer jeweler of Shasta.

Among the retail jewelers visiting in San Francisco last week were: A. O. Solberg, Everett, Wash.; J. R. Balkwill, Stockton, Cal.; C. E. Owen, Stockton; Mr. and Mrs. C. J. Noack, Sacramento, Cal.; A. C. Schulze, Dixon, Cal.; A. H. Ewert, Ukiah, Cal.

Rothschild & Hadenfeldt have completed their catalogue of quartz work. It contains photographs of all the different patterns of quartz work turned out by their factory. It is being furnished to their customers in the mining and other regions where this kind of work is popular.

On the night of Oct. 22 the old Berkeley watch factory, which has been for 25 years one of the best known of our suburban landmarks, was entirely destroyed by fire. The building was originally built as a home for the Cornell watch factory. The concern failed, however, and Rawson, the founder, having lost all his property, committed suicide in San Francisco Bay. The building was afterwards used as a shoe factory, but this also ended in failure and in suicide. At the time it was burned the immense structure was partly occupied by an incubating establishment and partly by chemical works. The building was three stories high and had a frontage of 100 feet. Its original cost was \$10,000.

ALL GOLD SIGNET RINGS.

## GEO. O. STREET & SONS,

24 JOHN ST., NEW YORK.

... Established 1837 ...



## Stern Bros. & Co.,

Cutters of ...

MANUFACTURERS OF

**DIAMONDS,** Gold Rings and Thimbles,

68 NASSAU STREET, NEW YORK.

RING FACTORY, 33-43 GOLD STREET, NEW YORK.

LONDON OFFICE, 29 ELY PLACE.

DIAMOND-CUTTING WORKS, 142-146 W. 14TH ST., NEW YORK. CHICAGO OFFICE, 149 STATE ST.

# The Mercantile National Bank

OF THE CITY OF NEW YORK,

BROADWAY AND DEY STREET,

Solicits Accounts from the Jewelry Trade.



**Death of M. S. Smith.**

DETROIT, Mich., Oct. 30.—Martin S. Smith, the founder of the old jewelry house of M. S. Smith & Co. and a man who was connected with some of the largest business interests of the State of Michigan, died Saturday night. He was best known as Gen. R. A. Alger's business partner, though he was widely known to the jewelry trade. When 10 years of age his family came to Michigan and located in Pontiac. He began work as a dry goods clerk in Detroit, and next entered a jewelry house, which in a few years he succeeded in buying. At the time of his death he was vice-president and treasurer of Alger, Smith & Co., a lumbering concern, which owns extensive tracts of land in Alcona, Alger, Chippewa and Schoolcraft counties, in the Northern Peninsula, and also on the northern shore of Lake Huron, in Canada. He was vice-president and treasurer of the Manistique Lumbering Co., president of the Manistique Railway Co., and of the Duluth & Northern Railway Co., president of the American Exchange National bank of Detroit and vice-president of the State Savings bank. He was also president of the Michigan Condensed Milk Co., a director of

the Union Trust Co., and treasurer of the Woodmere Cemetery Association.

The jewelry house to which he succeeded is now known as W. A. Sturgeon & Co., the successive changes in firm name from M. S. Smith & Co. being F. G. Smith, Sons & Co., F. G. Smith & Sons Co., Smith, Sturgeon & Co., and W. A. Sturgeon & Co. [A fuller obituary will be published in the next issue.]

**Cleveland.**

H. C. Thomas, of the Arcade Optical Co., was married last Thursday evening to Miss Florence Welch, of this city.

A box containing \$35 worth of silver ware was left by a drayman at the rear door of the jewelry store of Frank, Laubach & Clemmer Co., Akron, shortly after dark one evening last week. When a clerk went to get it it had disappeared.

Heimberger & Lind, 158 Pine St., Providence, R. I., in connection with their complete line of jewelers' findings, are showing something new in medallions and ebony mounts. A postal card addressed to the firm will bring samples.

**Imports of Precious Stones at New York During October.**

The importations of precious stones and pearls which passed through the Appraiser's Stores at the Port of New York for the month of October were yesterday reported by Jewelry Examiner Mindil as:

*Precious Stones and Pearls.*

Cut .....	\$1,233,748.21
Uncut .....	822,594.41
Total .....	\$2,056,342.65

A comparison with the importations for the same month during the three previous years is interesting. The figures are:

	<i>Cut.</i>	<i>Uncut.</i>
October, 1898.....	\$947,593.23	\$837,810.08
October, 1897.....	684,878.08	470,040.67
October, 1896.....	83,708.20	51,760.00

The "anniversary line" of 10-k. link buttons that the John T. Mauran Mfg. Co., Providence, R. I., are showing this Fall is one that every jeweler will find it profitable to examine. There are no old patterns in this line, every die being new this season. The buttons are guaranteed by the manufacturers not to break and any pair that does not give satisfaction will be replaced with a new pair without charge.

**WHO KILLED COCK ROBIN?**  
 THE SPARROW CLAIMS THAT HE DID,  
 PERHAPS THE SPARROW TOLD THE TRUTH.  
 WE HAVE A CLAIM TO MAKE THAT IS  
 BASED ON TRUTH BEYOND A  
 PERADVENTURE.  
 AND THIS IS THE CLAIM.  
**AMERICAN WATCHES.**  
 ELGINS WALTHAMS HOWARDS.  
 CERTAINLY  
 THE MOST COMPLETE  
 LINE IN AMERICA.  
**C. G. ALFORD & CO.**  
 195 BOWWAY NEW YORK.

# WARNING TO RETAIL JEWELERS

## Keep Tabs on the Tags and Swivels.

When you buy Blackinton Chains the stamps on swivels tell the story.

EACH TAG AND STAMP ON SWIVEL REPRESENTS A DIFFERENT QUALITY.



OLD RELIABLE

### W. & S. B. ★ GLOBE FILLED

ARE EXTRA QUALITY AND WARRANTED TO ASSAY  $\frac{1}{8}$  GOLD.

OUR REGULAR

### OLD RELIABLE W. & S. B. ★

ARE  $\frac{1}{10}$  PLATE AND SUCH AS WE HAVE MADE FOR 30 YEARS.

IF YOUR SWIVELS BEAR EITHER OF THE ABOVE TWO STAMPS YOU ARE SURE OF GETTING CHAINS THAT EXCEL IN

### QUALITY, DESIGN AND FINISH,

THE GREATEST OF VIRTUES THAT COMBINE TO MAKE A LINE OF GOODS

### RELIABLE AND SALABLE.

EVERY JOBBER CARRIES THESE CHAINS. INSIST ON SEEING THEM; A CAREFUL EXAMINATION WILL PROVE THE ABOVE.



EMPIRE STATE EXPRESS RUNNING 60 MILES AN HOUR.

★ **AND CRESCENT**

so stamped on Tag and on Swivel.

THIS IS  
OUR **2d QUALITY.**

**CAUTION**

Retailers when buying should be most careful to see that chains so stamped are not sold

as either the old reliable W. & S. B. ★ **GLOBE FILLED** or the old reliable W. & S. B. ★ **THIS IS BEING DONE AND HAS BEEN DONE EXTENSIVELY.**

SECOND QUALITY.



Trade

Mark.

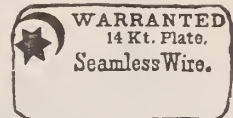

This Tag goes with this Swivel.

QUALITY.



Mark.

Reliable.  
W. & S. B. ★  
Seamless Wire.

with this Swivel.

**W. & S. BLACKINTON.**

Providence, R. I.

New York, 14 Maiden Lane.

# Solid Wire Gold Bracelets

Guaranteed to wear longer than any other make of Bracelet. Handsome chasing, first-class finish. Locks are all hand-made.

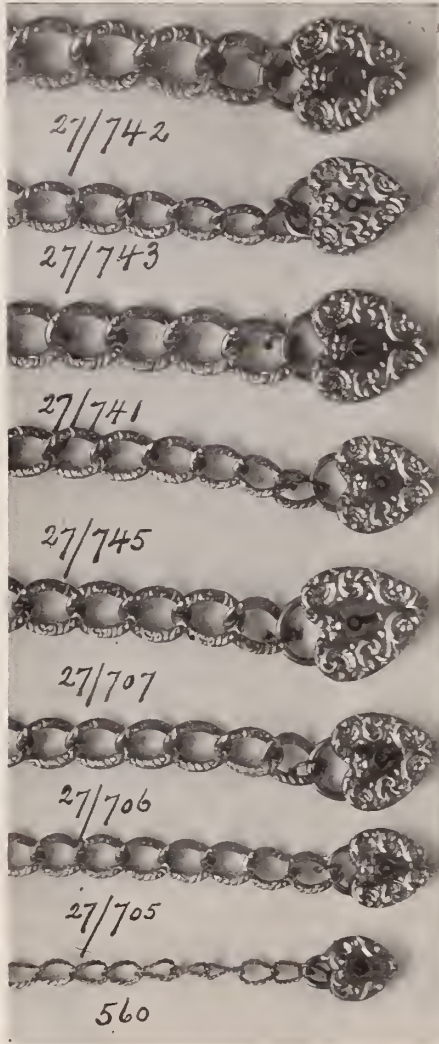

560, Baby size,	\$30.00 doz.	27-745, Full size,	\$90.00 doz.
27-705, Misses' "	54.00 "	27-741, "	114.00 "
27-706, Full "	78.00 "	27-743, "	3 reg. cut diamonds, 13.50 ea.
27-707, "	108.00 "	27-742, "	Extra heavy, 13.50 "

Less 6 per cent for cash with order. Selection package sent on request.  
Consult our 68-page catalogue of Xmas sellers.

**AVERBECK & AVERBECK, Manufacturers, - 19 Maiden Lane, N. Y.**

## Over \$15,000 of Diamonds Held.

### Investigation of a Quantity of Diamonds in the Possession of Adolph Peabody.

Acting on information laid by the Diamond Importers' and Cutters' Protective Association, which was collected by former Detective-Sergeant Heidelberg, the Collector of Customs in New York has now under advisement proceedings for the seizure of a quantity of diamonds and precious stones valued at more than \$15,000. The stones belong to Adolph Peabody, who was formerly a diamond importer at 37 Maiden Lane, New York, and who, as told in THE CIRCULAR at the time, skipped to Europe last year, but who afterward made a settlement with his creditors.

The case was put into the hands of Wm. H. Theobald, a Special Treasury Agent, who last week went to the office of Jos. Frankel's Sons, 68 Nassau St., and took from there a small package of stones belonging to Peabody, and delivered them at the Collector's office. Peabody was sent for by the Collector, and at the latter's request went to the National Park bank and brought down another package of stones which he owned. Mr. Peabody's explanation to the Collector as to his possession of these stones was apparently clear, but owing to a suspicious circumstance, the Collector decided to hold the stones until last Monday and give Mr. Peabody a chance to prove that they had either been cut or bought here, or that duty had been paid upon them. The charge against the goods is that they were smuggled into this country by way of Boston and then by Canada.

On Monday last Peabody submitted his affidavits to Col. Dudley S. Phelps, Deputy Collector in charge of the Law Division of the Custom House, who is investigating the case, and a decision is now pending.

## One of Our Latest Productions.

MANY OTHERS YOU WILL FIND ILLUSTRATED IN OUR

### NEW FALL CATALOGUE,

WHICH SHOULD BE IN YOUR POSSESSION.



Patented Sept. 12, 1899.

## S. STERNAU & Co.

.....Manufacturers of.....

Metal Wares in Brass,  
Copper and Silver,

204 Church St.,  
Corner Thomas St.,  
NEW YORK.

### Rockefeller Capital Put into the Webb C. Ball Co.

CLEVELAND, O., Oct. 29.—It has just been officially announced that an important change will be made in the conduct of one of Cleveland's foremost jewelry establishments. Rockefeller capital will henceforth play an important part in the furthering of the business interests of the Webb C. Ball Co., of this city.

At a meeting of the stockholders in the local offices of the company, Frank Rockefeller and Frank Brewster, of the Standard Oil Co., New York, identified themselves with the Ball company by investing in substantial blocks of stock. Frank Brewster was elected president of the company, with the following persons composing the directorate: Frank Rockefeller, Frank Brewster, J. A. Beidler, J. H. Dempsey, F. I. Ball, J. P. Dawley and Webb C. Ball.

It is the purpose of the company to push the Ball watch among railroad people and the public generally.

### Mason Jewelry Co., of Attleboro Falls, Go into Liquidation.

ATTLEBORO, Mass., Oct. 28.—The Mason Jewelry Co., of Attleboro Falls, went into liquidation to-day. Liabilities, \$7,578.08; assets, \$50.

**ANY BOOK** pertaining to the Jewelry, Horological, Optical or Kindred Trades can be obtained through The Jewelers' Circular Publishing Co., 11 John St., New York. Send for catalogue. It is free.

# The Jewelers' Circular

AND  
HOROLOGICAL REVIEW.

PUBLISHED EVERY WEDNESDAY BY  
**THE JEWELERS' CIRCULAR PUB'G CO.,**  
CORBIN BUILDING, 11 JOHN ST., COR. BROADWAY,  
NEW YORK.

TELEPHONE: 1148 CORTLANDT. CABLE ADDRESS: JEWELAR, NEW YORK.

A JOURNAL DEVOTED TO THE INTERESTS OF JEWELERS,  
WATCHMAKERS, SILVERSMITHS, ELECTRO PLATE MANU-  
FACTURERS, AND ALL ENGAGED IN KINDRED BRANCHES OF  
INDUSTRY.

Member of the American Trade Press Association.

Our editorial columns will contain our own opinions only, and we shall present in other columns only what we consider of interest or value to our readers. Advertising matter will not be printed as news.

Advertising rates in THE CIRCULAR are lower, considering the number of tradesmen reached by its large circulation, than in any other jewelry journal.

Notices of changes in standing advertisements must be received one week in advance; new matter can be received up to Monday.

## INFORMATION FOR SUBSCRIBERS.

### Terms of Subscription, Postage Prepaid.

	PER ANNUM.
United States and Canada, - - -	\$2.00
Foreign Countries in Postal Union, - - -	4.00
Single Copies, - - - - -	.10

New Subscribers can commence at any time.

Payments for THE CIRCULAR, when sent by mail, should be made in a Post-Office Money Order, Bank Check or Draft, or an Express Money Order or Registered Letter. All postmasters are required to register letters whenever requested to do so.

Pay money only to authorized collectors having proper credentials.

**Returning Copies.** Returning your paper will not enable us to discontinue it, as we cannot find your name on our books unless your address is given.

**Changing Address.** In changing address always give the old as well as the new one. Your name cannot be found on our books unless this is done.

**Discontinuances** We will continue to send papers until there is a specific order to stop, in connection with which all arrearages must be paid; but such an order can be given at any time, to take effect at or after the expiration of the subscription. All such orders will be promptly acknowledged by mail.

**Liability.** The courts have decided that all subscribers to journals are responsible until arrearages are paid in full and an order to discontinue has been received by the publisher.

### THE JEWELERS' CIRCULAR IN EUROPE.

Among the places in Europe where THE JEWELERS' CIRCULAR is on file are the following:

**LONDON**—First Ave. Hotel, Holborn, E. C.; Holborn Viaduct Hotel, Royal Hotel.  
**PARIS**—Hotel de L'Athene, Rue Scribe.  
**LEIPZIG**—Handels-Zeitung, für die gesamte Uhren-Industrie.  
**BERLIN**—Deutsche Uhrmacher Zeitung, Jäger-Strasse, 73.  
**GENEVA**—Journal Suisse D'Horlogerie.  
**AMSTERDAM**—Continental Club, Hotel Amstel.  
**ANTWERP**—Diamond Club, Rue de Pelican.

Vol. XXXIX. Nov. 1, 1899. No. 14.

Every line of reading matter in THE JEWELERS' CIRCULAR, with the exception of the few brief extracts from exchanges, always properly credited, is written exclusively for this journal. Each issue of THE JEWELERS' CIRCULAR is copyrighted. Permission to quote is extended to other publications provided such quotations are properly credited.

THE quieting down of trade last week was directly attributable to the prolonged, unseasonably warm weather in most sections of the country. Now that November weather prevails the Fall activity has been resumed and will increase in geometrical progression, so to speak, till the close of the holidays. The microbe of oniomania, the term Nordau uses to designate the buying fever, is in the air, and the public are universally affected by it. The holidays of 1899 will be the greatest present giving season on record.

### The End of the Jewelers' Strike.

WHAT was from the outset a foregone conclusion to the New York journeymen jewelers' strike has come to pass: those who had not already slipped back to work, on Saturday night, declared the strike off and on Monday morning returned in mass to work to their respective shops. It had become evident to the most blind and ardent striker within the past fortnight that no true unanimity of action existed among the men, that many were slipping back to work and that still more were inclined to give up the fight. They began to understand that the blandishments of the firms who were willing to accede to their demands were really not very tempting, for it was the practices of these very firms that precipitated the strike, and even if they were willing to live up to the strikers' demands, the amount of increased wages would not be very great. Manufacturers who paid their men \$10 per week could afford to give them a percentage more without much suffering on their part. They were by far the most generous, the most liberal, the most extensive and best established and the most just manufacturing firms who held out, firms that pay their men from \$15 to \$50 or more a week, in accordance to the class and amount of work done. We are happy to see that the men have come to appreciate these facts and to discern who are their best friends. Now that the manufacturers have won the day, although their season's profits will be greatly reduced if not altogether dissipated, we urge upon them the wisdom of exercising toward their forces collectively and individually the most liberal treatment that the circumstances permit. But this urging is hardly necessary, for there is no industry in which the community of workmen and employers generally has been so close and so harmonious as in the manufacturing of jewelry. The newer element among the workmen, persons of comparatively recent residence in America, may not yet have become amalgamated in the body of the trade and assimilated its traditions, and perhaps the spirit of the times will hardly permit such amalgamation and assimilation. It is this element that the strike idea is apt to affect; but it is the natural instinct of expediency, if nothing else, that urges them to give in to the older and deeper rooted sentiments and obligations of the trade.

IN the news columns of this issue is the report of the burglarizing of a jewelry store while the proprietor was asleep in an adjoining room looking into the store.

To insure publication in the following issue, order for space for NEW advertisements must be received not later than Monday noon.

It has always seemed to us that the jeweler who sleeps in his store assumes an additional risk, for he puts his life in jeopardy, the desperate burglar seldom hesitating to commit murder in order to escape arrest. It is this chance of the burglar committing murder that makes the punishment for burglary so severe. The burglar's greatest concern is to keep himself out of the law's hands, and this is the reason why he gives a wide berth to those jewelry stores showing the door plate or certificate of the Jewelers' Security Alliance, for he knows that the members of the Alliance have at their service the long reaching arm of the Pinkerton Detective Agency. He has little fear of the local police machinery of the third, fourth or lower rate cities and towns, and, therefore, has little hesitation in entering the store that depends for protection only upon this machinery.

### American Watch Cases in Switzerland.

OUR Swiss contemporary, *Solidarité Horlogère*, sounds a note of warning to its readers with respect to the increasing importation into Switzerland of plated (so called *plaqué*) watch cases from the United States. During the last year alone more than 200,000 of these cases, valued at about 2,000,000 francs, were imported into Switzerland, and the writer of the article predicts that a few years hence the Americans will flood Switzerland with cases of gold, silver and other metals as well. The paper appeals to the Swiss manufacturers not to look on this "invasion" any longer with folded arms, but to meet it effectively with improved modes of manufacture. "In order that further steps be taken than merely the utterance of empty phrases," it opens at the head of the same number a subscription addressing the "watchmakers' unions and citizens who take an interest in the welfare and development of the horological industry," and stating that for conducting the necessary preliminary labors to ascertain suitable methods for the manufacture of *plaqué* cases the sum of 1,500 francs would be sufficient. "The United States," continues the quoted paper, "exports to Switzerland three kinds of cases, namely, plated cases, gilt cases and electro-plated cases. It is the last which cause Switzerland anxiety, since in 1898 alone no less than 240,000 were imported. The cases are made of non-precious metal, which is provided with a strong gilding by the electro-deposition process. Before the plating—and this," says the *Solidarité Horlogère*, "is the peculiarity of the method—the cases are entirely completed. They are engraved and engine turned, finished and polished, and only then subjected to the gilding process." We opine that American ingenuity will keep ahead, no matter what may be done by the Swiss.

## BUYERS' INFORMATION BUREAU.

Questions as to the makers of certain lines of goods, where to buy certain lines, where certain kinds of work are done, the owners of certain trade-marks and other matters relating to the buying branch of a jewelry business will be cheerfully answered under this department. The reader cannot ask too many questions.

KANSAS CITY, Mo., Oct. 22, 1899.

Editor of THE JEWELERS' CIRCULAR:

Noticing in edition of Oct. 18, page 32, that J. H. Hutchinson & Co., of Portsmouth, N. H., ask for a pattern of cut glass called "Kensington," would beg to inform you that T. G. Hawkes & Co., of Corning, N. Y., make a full line of "Kensington." Yours truly,

W. H. BRYANT,

Traveler for T. G. Hawkes & Co.

OTTAWA, Canada, Oct. 20, 1899.

Editor of THE JEWELERS' CIRCULAR:

Will you kindly inform me through your "Information Bureau" the name of a good journal devoted to jewelers' and opticians' advertising, and oblige,

Respectfully yours,

M. ROSENTHAL.

ANSWER.—There is no journal exclusively devoted to jewelers' and opticians' advertising. All the jewelry and optical papers claim to give some attention to this subject. Correspondent may have noticed that THE CIRCULAR has a department called "Advice and Criticism on Retail Jewelers' Advertising," which appears intermittently with the department devoted to window dressing and miscellaneous matters connected with the conducting of a jewelry store. We recommend as valuable aids to

the retail jeweler in the preparing of his advertising the following periodicals devoted to advertising generally: *Printers' Ink*, 10 Spruce St., New York; *Fame*, 1 Union Square, New York; *Brains*, 150 Nassau St., New York; *Advertising Experience*, Boston, Mass.

CUYAHOGA FALLS, O., Oct. 21, 1899.

Editor of THE JEWELERS' CIRCULAR:

Where can I get coral beads repolished? Also do same parties cut sets, say one or two sets out of a large coral bead? Where can I buy loose coral sets for mounting? Very thankful for past information, and will be more so for above. Respectfully,

B. F. PHILLIPS.

ANSWER.—Correspondent can get coral beads repolished as well as cut by Fox & Co., lapidaries, 22 John St., New York. Coral sets for jobbing can be obtained from Albert Lorsch & Co., 37-39 Maiden Lane, New York, and from Nordlinger & Mamluck, 24 John St., New York.

DULUTH, Minn., Oct. 22, 1899.

Editor of THE JEWELERS' CIRCULAR:

Do you have the "Encyclopedia-Dictionary and Reference Handbook of the Ophthalmic sciences," bound in book form? If so, at what price?

Yours,

P. H. KREITZ.

ANSWER.—This work has not been published in book form, and will not be until it has been completed in the pages of THE JEWELERS' CIRCULAR.

## Last Week's New York Arrivals.

THE CIRCULAR has perfected arrangements for obtaining the names and hotel addresses of all the latest buyers visiting New York, and each day posts in its office, 11 John St., cor. Broadway, a bulletin which every member of the trade is cordially invited to copy.

Mrs. B. B. Perkins, St. Albans, Vt., Park Ave. H.; J. F. Jones (J. N. Adams & Co.), Buffalo, N. Y., 55 White St.; W. F. Staley, Pittston, Pa., Imperial H.; E. Gundlach, Hartford, Conn., Park Ave. H.; G. E. Spaulding (Spaulding & Co.), Chicago, Ill., Holland H.; T. S. Ayres, Elmira, N. Y., Empire H.; D. F. Leary, Springfield, Mass., Grand Union H.; L. W. Vilsack, Pittsburgh, Pa., Imperial H.; F. S. Collins (Adam, Meldrum & Anderson), Buffalo, N. Y., 2 Walker St.; I. W. Vidito (M. S. Brown & Co.), Halifax, N. S., St. Denis H.; A. M. Hill, New Orleans, La., Herald Square H.; H. E. Adams, Sanford, Fla., 114 E. 24th St.; D. B. Ryland (Ryland & Rankin), Lynchburg, Va., Cadillac H.; Wm. Glover, Jr., Hazleton, Pa., Marlborough H.; J. A. Reed (J. R. Reed & Co.), Pittsburgh, Pa., Imperial H.; F. C. Clark (Clark & Engle), Wilkes-Barre, Pa., St. Cloud H.; T. Blum (The Rosenfeld Notion Co.), Galveston, Tex., Albert H.; J. H. Leyson, Butte, Mont., Imperial H.; H. Schussler, San Francisco, Cal., Holland H.; W. Jardine (Gilchrist & Co.), Boston, Mass., Murray Hill H.; H. B. Ross (Ross Bros.), Calais, Me., St. Denis H.; Geo. M. Marckres, Sharon, Conn., Grand Union H.; J. H. Humburch (McAllaster & Humburch Bros.), Rochester, N. Y., New Amsterdam H.; J. Castelberg, Baltimore, Md., Imperial H.; J. Green, Scranton, Pa., Broadway Central H.; G. E. Bixby (Bixby Silver Co.), Providence, R. I., Cadillac H.; R. D. Graves, Corning, N. Y., St. Cloud H.; C. C. Mussina, Williamsport, Pa., St. Cloud H.; F. A. Gruen (D. Gruen & Sons), Cincinnati, O., Union Square H.; H. W. Phelps (Merrick, Walsh & Phelps Jewelry Co.), St. Louis, Mo., Holland H.; F. M. Sproehle (Sproehle & Co.), Chicago, Ill., Imperial H.; T. J. Church, Auburn, N. Y., Marlborough H.; Mrs. P. L. Lowenthal, Bradford, Pa., Union Square H.; J. R. Graves, Corry, Pa., Bartholdi H.; R. H. Conlyn, Carlisle, Pa., St. Denis H.; D. G. Braham (Stix, Baer & Fuller), St. Louis, Mo., 60 Lispenard St.; P. A. Haberl (Haberl Lapidary & Jewelry Co.), Denver, Col., Grand H.; S. Stern (Sanger Bros.), Dallas, Tex., 22 Lispenard St.; Adam Fisher, Greensburg, Pa., Astor H.; A. S. Harwood, Boston, Mass., Manhattan H.

A. Snyder, Council Bluffs, Ia., has given a bill of sale to S. Snyder.

In a fire in Kenosha, Wis., Oct. 28, Herman Moeller, jeweler, sustained a loss on stock of about \$500.

W. W. Browne, manager of the Chicago branch of the Holmes & Edwards Silver Co. plant of the International Silver Co., has returned from a three days' business trip to Milwaukee.

## IF THE BOERS DO THIS

**WAR TO MAKE DIAMONDS DEAR.**  
Special to *The New York Times*.  
"The Boers" it is said, to-day, "have threatened to destroy the diamond mines, and there is no telling how long it would take to get them in working shape again. Diamond mines are from 800 to 1,100 feet deep, and can be ruined by the explosion of a bomb. To put them back into a condition so that they can be worked again would require an outlay of from \$1,000,000 to \$3,000,000, and then it would be a question whether the English investors would care to go to such an expense to relieve their properties. The stock of diamonds will not last more than a year, and should the mines be destroyed the values may double within a year."

what will you pay for diamonds?  
Two rises so far this month.  
Buy what you'll need NOW! we'll send anything you want—loose or mounted—"On Memo".

USSES THE BOERS  
V. WARING, N.Y.

## CROSS &amp; BEGUELIN

Importers and Cutters of Diamonds and Precious Stones

43 Rue de Meslay, PARIS

17 Maiden Lane, NEW YORK

**New York Notes.**

J. A. Flomerfelt has entered a judgment for \$290.61 against Geo. E. Matteson.

In the action of L. Tannenbaum & Co. against Lewis, which came up before Judge Fitzgerald, in the Supreme Court, Friday, a judgment was allowed for the plaintiff for \$534.15.

I. Stern and others have entered judgments for \$613.46 against W. B. Smith, and for \$611.52 against Jacob W. Smith. The Mutual bank has entered judgment against the latter for \$600.40.

Edward Henry Hessels, son and partner of Anthony Hessels, of A. Hessels & Co., 354 Columbus Ave., was united in marriage with Miss Elizabeth G. Mangles, daughter of Henry C. Mangles, at the home of the bride at Bayside last week.

In the Supreme Court last week an order was granted authorizing a citation to all creditors of the defunct Johnston Jewelry Co. to appear in court at a day to be named and show cause why the accounts of the assignee, Henry A. Kirby, should not be settled.

The firm of Schumacher, Jennings & Co., manufacturing jewelers, 20 Maiden Lane, recently dissolved, John Schumacher retiring. The firm have been succeeded by Jennings, Carragher & Co., composed of C. P. Jennings, J. Carragher and Geo. Bleam, who continue the business as before at the old address.

All persons interested in the estate of John Mason, who was adjudicated a bankrupt May 20, are notified that the first meeting of creditors will be held at the office of F. K. Pendleton, referee, 44 Broadway, Nov. 8, at 12 o'clock noon, at which time the creditors may attend, prove their claims, appoint a trustee, examine the bankrupt and transact such other business as may properly come before said meeting.

In the Supreme Court Friday Justice Scott appointed Everett B. Heyman receiver in supplementary proceedings for Elma Foley, of 131 E. 47th St., wife of John Foley, gold pen manufacturer, 5 Dey St. The appointment was made on the application of Joseph R. Jackson, who recovered a judgment against Mr. and Mrs. Foley on July 6 for \$4,098. She could not be found at her home or at his office to be served with the summons. It was stated that there was \$128 to her credit in the National Bank of the Republic, and that she owns household effects and ornaments not exempt and an interest in a shoe patent and other property.

In the Myrtle Ave. Police Court last

week John Sbrignadello, retail jeweler, 1043 Fulton St., Brooklyn, was a prisoner before Magistrate Lemon on a charge of disorderly conduct. James Doyle, deputy sheriff, was the complainant and testified that on Oct. 18 he went to Sbrignadello's store with a chattel mortgage. Doyle said that the jeweler asked to see the paper, then tore it up and placed it in the fire. Sbrignadello denied the charge in full and even denied that Doyle had a mortgage with him. Magistrate Lemon did not believe the jeweler's story and fined him \$5 for his action, telling the officer that he would listen to a charge of perjury if another witness could be produced.

The Sheriff Saturday received three executions, aggregating \$3,020, against the Majestic Silver Company, manufacturers of silver plated ware at 290 Pearl St., in favor of the following: Edward E. Nobis, \$2,066, for salary; Irwin D. Siegel, \$699, and Thomas S. Corey, \$255, both on claims for salary. Mr. Nobis was the president of the company. He started the business in 1886, and the company succeeded to the business on Jan. 7 last. The company occupy three floors at 290 Pearl St., and the Sheriff has taken possession. The concern were incorporated Feb. 1 with an authorized capital stock of \$50,000, \$30,000 of which was paid in. E. E. Nobis was president, Henry Marsch was vice-president, and L. A. Hakes secretary and treasurer.

Nelson M. Shepard, an old dealer in badges and medals of this city, died Oct. 24 at his home, 352 Schermerhorn St., Brooklyn. Mr. Shepard, who is said to have been in the jewelry trade for about 35 years, was born in Winsted, Conn., in 1835. He formed the firm of Haywood & Shepard about 1872, and when this firm dissolved in 1875 he continued alone until he became embarrassed and made an assignment Jan. 2, 1883. After settling with his creditors he again resumed business, and in recent years was in partnership with his son, Harry W. Shepard, under the style of Nelson M. Shepard & Co. The business has been located for many years at 102 Fulton St., New York. The deceased was prominently identified with Sylvan Grove Lodge F. & A. M. The remains were interred at Portland, Me.

In the Adams St. police court, Brooklyn, last week, Alexander Miller, 24 years old, who lives at 1124 Bushwick Ave., was arraigned before Magistrate Brenner charged with being a suspicious person. He had been arrested with a number of pawn tickets in his possession and under circumstances which in the opinion of Capt. Rey-

# Cut Glass.

BEST STYLES,  
LATEST IDEAS,  
LARGEST STOCK.

**C. DORFLINGER & SONS,**

36 Murray Street  
and 915 Broadway,

NEW YORK.

## Jewelry Store Style

is embodied to a remarkable extent  
in the Holiday styles of

## Waterman's Ideal Fountain Pen.

They are the most beautiful articles of unlimited usefulness that your stock contains. Have a full stock; there's advantage in it.

**L. E. Waterman Co.,**  
155-157 Broadway, New York.

Largest Manufacturers of  
Fountain Pens in the World.



1851.

1899.

# THE CHATHAM NATIONAL BANK, NEW YORK.

CAPITAL STOCK, - - - \$450,000  
UNDIVIDED PROFITS, - - - 974,518

H. P. DOREMUS, Cashier.

GEO. M. HARD, President.

W. H. STRAWN, Ass't Cashier.

nolds, of the detective squad, warranted some further investigation. Miller was searched, and 11 pawn tickets, all issued from the pawn shop at 181 Bowery, were found in his pockets. He said that he was a plumber by occupation, but that he made a business of dealing in pawn tickets. One of the tickets represented 35 diamonds, and \$300 had been loaned. The captain asked the prisoner how it happened that 35 gems had been pledged at once and was told that they were from a diamond sun burst that was broken up. The answer made the captain suspicious, for as a rule the only persons who break up jewelry to pledge are men who get gems dishonestly. So he asked the magistrate to postpone the hearing in the case until the young man's antecedents could be looked up. The tickets in

his possession were, with the exception of one for a gold watch, for diamonds, and they represented about \$2,000 loaned. Miller says that he bought the tickets on speculation from a ticket broker on the Bowery. He does not account for his knowledge of the manner in which the 35 diamonds were pledged.

Moses Bruhl, the well known diamond importer and member of the old firm of Bruhl Bros. & Co., is lying critically ill at his home, 21 W. 38th St.

Wm. Scheer, manufacturing jeweler, formerly of 17th St. and Broadway, has moved to new and more commodious quarters at 35th St. and Fifth Ave.

The marriage of Miss Ann Archer, of Baltimore, to Louis Emile Addison de Goll, formerly of the Roy Watch Case Co.,

took place on Saturday at "Shamrock," near Bel Air, the Summer home of the bride's mother.

The following firms have applied for membership in the Jewelers' Association and Board of Trade: The C. F. Monroe Co., Meriden, Conn.; Chas. S. Crossman & Co., New York; Freudenheim Bros. & Levy, New York.

Irving L. Russell, who gives his occupation as traveling salesman (he is a traveler for L. Tannenbaum & Co.), filed a petition in bankruptcy Monday with liabilities of \$7,795 and no assets. He was formerly a dealer in diamonds at 18 John St.

Florence Kroeber, president of the F. Kroeber Clock Co., who was appointed temporary receiver of the company in liquidation proceedings some months ago, was Monday appointed permanent receiver of the corporation by Judge Bookstaver, of the Supreme Court.

The American Turquoise Co., whose principal office is at 243 Washington St., Jersey City, N. J., were incorporated in New Jersey last week to deal in precious stones. The capital is \$100,000. Cortland Betts, Morristown, N. J.; Frederic N. Gilbert, Brooklyn, N. Y.; Cornelius A. Loughlin, New York city, are the incorporators. This concern, it was learned, has nothing to do with the American Turquoise Co., now known to the trade and for whom J. G. Doty, 14 John St., is the agent.

Some time ago, Mrs. Rachael Flint obtained from the Supreme Court an order granting her leave to become a party defendant in the action brought by Clara Montague, as executrix of the late Henry E. Droz, against the Jewelers' and Tradesmen's Company. Droz was, before his death, an old and well known importer and jobber of watches, and the action was over insurance on his life. His executrix opposed the making of Mrs. Flint a party defendant in the action and appealed from the order before named. Argument on the appeal was heard Monday by the Appellate division of the Supreme Court.

#### Difference Between Clock and Watch Time May Cost a Vote.

[New York Press.]

**B**ECAUSE of a difference between his watch and the clock in a registration booth, Herman A. Brand, a lawyer, of 17 E. 112th St., says he was not permitted to enroll himself. So he has secured from the Supreme Court an order directing the election inspectors of the Fourth election district of the Thirty-first assembly district to show which timepiece was correct and why they should not add his name to the voting list.

It was 9.54 by his watch, Mr. Brand says, when he entered the registration place. After waiting a minute while another man was being enrolled, one of the officials looked at the clock on the wall, which showed it was half a minute after 10 o'clock. The official told him he was too late. Mr. Brand showed his watch and protested, but all to no purpose, for the inspectors would not enroll him. So he went to court.

Telephone or send your orders, memorandum or regular,

TO

## INGOMAR GOLDSMITH & CO.,

30 MAIDEN LANE, NEW YORK.

Telephone, 5419 Cortlandt.

### STONE DEPARTMENT.

Diamonds and all Precious Stones Unmounted

SPRING IMPORTATIONS ONLY, evidencing prices 20 per cent lower than since last advance.

### Factory Department.

Diamond Set Jewelry of any description in large variety.

Mountings and Settings in 14 k. and 18 k., full line. Ring Mountings sold by dwt. Special order work always given prompt service. Estimates and Designs without charge.

## Rubies and Emeralds.

BYRON L. STRASBURGER & CO.,

Watches and Diamonds,

17 MAIDEN LANE,

NEW YORK.



## Special Notices.

Rates 75c. per insertion for notices not exceeding 3 lines (25 words); additional words 2 cents each. If answers are to be forwarded, postage stamps must be enclosed. Two insertions, 15 per cent off; three insertions, 20 per cent off; four insertions or more, 25 per cent off. Payable strictly in advance.

Display cards on this page will be charged at \$2.00 per inch for first insertion, subject to same discount as above for subsequent insertions.

Under the heading of **SITUATIONS WANTED** on this page advertisements will be inserted for One Cent a Word, each insertion, no discount, but no advertisement will be inserted for less than 25 cents. This offer refers to **SITUATIONS WANTED ONLY**. Payable strictly in advance.

In all cases if answers are to be forwarded, 10 cents extra to cover postage must be enclosed.

## Situations Wanted.

**YOUNG LADY**, 8 years' experience in office work and taking charge of stock in jewelry factory; highest references. B. H., care Jewelers' Circular.

**SITUATION WANTED** by watch, clock and jewelry repairer with full set of tools; a first-class salesman; age 27 years. Address "Cash," 212 Nepperhan Ave., Yonkers, N. Y.

**PRACTICAL DESIGNER**, with 15 years' experience in all branches of sterling silver ware, desires position; All references furnished. Address "Sterling," care Jewelers' Circular.

**SUPERINTENDENT AND DESIGNER** with large experience in all branches of sterling silver ware desires position; best of references. Address "Designer," care of Jewelers' Circular.

**YOUNG MAN** of several years' experience, also well known among the wholesale and retail trade, desires to obtain a manufacturing jeweler's line on commission basis; security furnished if necessary. Address "Ambitious," care Jewelers' Circular.

**A FIRST-CLASS OPTICIAN**, watchmaker and engraver will be open for a position about Nov. 1; age 32, having had 14 years' practical experience; can take full charge of store if wanted to, having optical case and tools; none but first class firms need answer; All references furnished. Address O. W. E., care Jewelers' Circular.

## Help Wanted.

**WANTED**—A fine engraver and watchmaker until Feb. 1, with prospects of permanent position. Hussey, Hyde & Co., Salem, Mass.

**WANTED**—A good watchmaker; situation permanent to right man. Address D. C. Percival & Co., Jewelers' Building, Boston, Mass.

**WANTED**—First-class letter, monogram and ornamental engraver; permanent position for right man. Address M. C., care Jewelers' Circular.

**WANTED**—A first-class engraver who can also do small jewelry repairing. Send sample of work and references to Henry Kohn & Sons, Hartford, Conn.

**WANTED**—A first-class engraver and jeweler; must be good workman; permanent. Address, with references, not later than Nov. 15, Franz Mahneke, Tacoma, Wash.

**A YOUNG MAN** that can do all kinds of job work and clock work and salesman; must be sober and industrious; state wages wanted. Address Bauer Bros., Zanesville, O.

**EXPERIENCED MAN** who can superintend and design; understands the manufacturing of jewelry in all its branches; good references. Address "Expert," care Jewelers' Circular.

**WANTED**—A first-class watchmaker and jeweler; permanent position to right man; must be sober, honest and industrious; to go south at once. Address "Haste," care Jewelers' Circular.

## INDEX TO ADVERTISEMENTS.

Aikin, Lambert & Co.....	55	Kendrick & Davis.....	47
Aikin, Lambert Jewelry Co.....	55	Knowles, Dr.....	52
Albert Bros.....	41	Knowles, J. B. & S. M., Co.....	7
Alford, C. G., & Co.....	28a	Kohn & Co.....	25
American Watch Case Co.....	55	Kohn, Alois, & Co.....	52
Arnstein Bros. & Co.....	56	Le Boutillier & Co.....	56
Atlas Watch Co.....	39	Lederer, S. & B., Co.....	56
Austin, John, & Son.....	56	Ledos Mfg. Co.....	27
Averbeck & Averbeck.....	28d	Lewis, Fred W., & Co.....	23
Avery & Brown.....	16	Levy, L. W., & Co.....	27
Ball, Wm. H., & Co.....	54	Lind, Thomas W.....	8
Bassett Jewelry Co.....	4	Malliet, C. G., & Co.....	23
Bell Watch Case Co.....	21	Mathews & Prior.....	12
Bene, Lindenberg & Co.....	41	Mauran, John T., Mfg. Co.....	43
Billings, Chester, & Son.....	23	Mathey Bros., Mathez & Co.....	55
Blackinton, W. & S.....	28b, 28c	Mauser Mfg. Co.....	5
Borgzinner, S. & A.....	50	Mercantile National Bank.....	28
Bowden, J. B., & Co.....	22	Monroe, C. F., Co.....	37
Bradley Polytechnic Institute.....	56	Mount & Woodhull.....	22
Bradley & Hubbard Co.....	52	Myers, S. F., Co.....	28
Bryant, M. B., & Co.....	54	New England Watch Co.....	17
Chatham National Bank.....	31	Omega Watches.....	16
Clark & Coombs.....	55	Oppenheimer Bros. & Veith.....	23
Conley & Straight.....	56	Oskamp, Nolting & Co.....	41
Cook, Edward N.....	17	Providence Stock Co.....	56
Cross & Beguelin.....	30	Pairpoint Mfg. Co.....	52
Crossman, Charles S., & Co.....	36	Philadelphia College of Horology.....	20
Crouch & Fitzgerald.....	52	Reichhelm, E. P., & Co.....	52
Day, Clark & Co.....	36	Reisner, L. C., & Co.....	3
Deutsch Bros.....	11	Remington Typewriters.....	27
Delaware Ophthalmic College.....	36	Revell, Alexander H., & Co.....	42
Dorflinger, C., & Sons.....	31	Rich, H., & Co.....	52
Dover, Geo. W.....	45	Robert, E. E.....	17
Dubois Watch Case Co.....	17	Roy Watch Case Co.....	20
Dueber-Hampden Co.....	15	Rumpp, C. F., & Sons.....	44
Eaton & Glover.....	52	Saunders, John F.....	23
Eisenmann Bros.....	24	Schulz & Rudolph.....	22
Eliassof Bros. & Co.....	36	Sherwood, John W., & Co.....	14
Esser & Barry.....	55	Simmons, R. F., & Co.....	46
Fahys, Jos., & Co.....	18	Simmons & Paye.....	36
Fairchild & Johnson Co.....	56	Simons, Bro., & Co.....	35
Finley, Freeman J.....	43	Smith, Alfred H., & Co.....	24
Follmer, Clogg & Co.....	44	Stern Bros. & Co.....	28, 45
Foster, Theodore W., & Bro. Co.....	2	Sternau, S., & Co.....	28d
Fox & Co.....	22	Strauss, Sig., & Co.....	41
Frankel's Sons, Jos.....	21	Strasburger, Byron L., & Co.....	32
Freund, Henry, & Bro.....	36	Street, Geo. O., & Sons.....	28
Friedlander, R., L. & M.....	56	Sussfeld, Lorsch & Co.....	50
Frohman & Co.....	41	Towle Mfg. Co.....	42
Fuchs, Ferd., & Bros.....	55	Treibs Bros.....	25
Goldberg Bros.....	41	Trenton Watch Co.....	20
Goldsmith, Ingomar, & Co.....	32	Wadsworth Watch Case Co.....	41
Goodnow & Jenks.....	13	Wallace, R., & Sons Mfg. Co.....	6
Gorham Mfg. Co.....	2	Waterman, L. E., Co.....	31
Gregory, E. J.....	16	Westphal, W. C. A.....	55
Harris & Harrington.....	56	Wheeler, Hayden W., & Co.....	26
Hayden Mfg. Co.....	12	Whiting, F. M., & Co.....	8
Hedges, Wm. S., & Co.....	22	Windsor Mainsprings.....	43
Hemberger & Lind.....	54	Wittnauer, A.....	19
Herman & Loeb.....	41	Wood, Chas. F., & Co.....	56
Howard Sterling Co.....	9	Wood & Hughes.....	52
Hraba, Louis W.....	52	Woods, John R., & Sons.....	52
Jacot & Son.....	55	Woods & Chattelier.....	10
Juergensen, Jules.....	22	Zimmern, Rees & Co.....	25
Kahn, L. & M., & Co.....	56	Zurbrugg, T., Co.....	36

**WANTED**—Watchmaker, jeweler and engraver, single man preferred; all around helper, with tools; \$12 per week; send sample of engraving, references and photograph in first letter; give full particulars; this is a steady job for right party; good store, nice town, in New York State; board and room cost \$3.50 to \$4 per week. Address "Jeweler," care Jewelers' Circular.

## Business Opportunities.

**A N OLD ESTABLISHED** jewelry store for sale on account of death of proprietor. Mrs. O. Zamow, 255 First Av., New York.

**FOR 30 DAYS** I offer my jewelry business, or fixtures only, at a very low price; I have been established 35 years. Wm. F. Wallace, Westerly, R. I.

**JEWELRY STOCKS BOUGHT**—Retailers wishing to dispose of surplus or entire stock of diamonds, watches and jewelry can find quick, cash, strictly confidential buyer by addressing S. Marx, 22 Lispenard St., New York City.

## To Let.

**OFFICE ROOM** to let to nice, quiet firm with us; terms \$25 per month. A. S. Gardner & Co., Room 73, Hays Building, 21 and 23 Maiden Lane.

## TO RENT in Silversmiths' Building, CHICAGO.

A fine office on Wabash Avenue front, with north and east light, 20 x 42 feet, adjoining the Gorham Mfg. Co.'s salesroom on the sixth floor. Most desirable location in the city. For terms apply to

**GORHAM MFG. CO.,**

Silversmiths' Building, CHICAGO.

**ANY BOOK** pertaining to the Jewelry, Horological, Optical or Kindred Trades can be obtained through The Jewelers' Circular Publishing Co., 11 John St., New York. Send for catalogue. It is free.

## How Many Customers Have You Lost

through your inability to duplicate a piece of jewelry or silverware or a watch? You need not lose these customers—you can gain new ones. The maker of almost any article brought to you can be ascertained by referring to

### **TRADE MARKS** OF THE JEWELRY AND KINDRED TRADES

which, with a supplement just issued, contains over 2,250 marks, covering every line handled by jewelers, besides other interesting and valuable information.

**Price, Book and Supplement, \$3.00.**

Handsomely bound, artistically printed, systematically arranged and indexed.

Published by **The Jewelers' Circular Pub. Co.,**

Corbin Building, 11 John Street, cor. Broadway, N. Y.

Send for sample page and circulars.

## Effective Advertising for Retail Trade.

The most striking and artistic method of advertising a retail Jeweler can employ is to send to his customers a copy of "Famous Diamonds of the World." This is an artistically printed booklet containing engravings of the famous diamonds of the world, together with a description and history of the stones. It is a book that will be read and preserved by every one receiving a copy.



FAC-SIMILE OF COVER.

32 PAGES.  
HARD,  
CALENDERED  
PAPER.  
ARTISTICALLY  
PRINTED.  
FINE  
HALF TONE  
ENGRAVINGS.  
BOUND IN  
COLORED  
ENAMELED  
PAPER  
COVER.

YOUR  
NAME ON  
FRONT  
COVER  
AND YOUR  
ADVER-  
TISEMENT  
ON BACK  
COVER  
MAKE  
THIS BOOK  
ESSENTIALLY  
YOUR OWN  
PUBLICATION.  
EXCLUSIVE  
RIGHT GIVEN  
FOR TOWNS  
OR CITIES.

By printing these in large quantities we are enabled to sell them to Retail Jewelers below the cost of ordinary pamphlets that have no intrinsic value and are thrown away. The price is so low that it will permit of its wide distribution to the public. Write for Sample Copy and Prices.

**JEWELERS' CIRCULAR PUB. CO.,** Corbin Building, 11 John St., cor. Broadway, New York.

### **JUST RECEIVED.**

## "Precious Stones ...and Gems,

Their History, Sources  
and Characteristics,"

By **EDWIN W. STREETER,**  
London, England.

ILLUSTRATED WITH COLORED PLATES.

**SIXTH EDITION.**

Revised and largely re-written up to date.

**345 pp. Price, \$6.**

The contents of the volume may be briefly summarized as follows: Precious stones in general—Sources; history; working; cutting (including various forms); engraving and carving; burning and coloring; and trade conditions (50 pp.); diamonds (95 pp.); rubies (31 pp.); sapphires (14 pp.); star stones, spinel and bolas (5 pp.); emeralds (10 pp.); true cat's eye and Alexandrite (5 pp.); opals (5 pp.); turquoise (14 pp.); semi-precious stones, about 40 varieties (74 pp.). Classifications, appendices and index occupy the remaining 34 pages.

The Jewelers' Circular Publishing Co.,  
11 JOHN STREET,  
Corner Broadway, NEW YORK.

## THIRD EDITION WORKSHOP NOTES —FOR— Jewelers and Watchmakers.

Being a collection of the latest practical receipts on the manufacture and repairing of watches and clocks and on the various processes entering into the manufacture and repairing of jewelry, as coloring polishing, enameling, annealing, oxidizing, etc., in short, a thorough compendium of the numerous mechanical departments of the jewelers' and watchmaker's shop.

Containing 300 pages. (Size, 7½ x 10¼ inches),  
Bound in Cloth, Stiff Covers.

This book is the most useful, comprehensive and perfect publication of the kind now in print and should be in the hands of every jeweler and watchmaker in the country.

**PRICE, \$3.00.**

PUBLISHED BY  
**The Jewelers' Circular Pub. Co.,**  
11 JOHN ST., cor. BROADWAY, N. Y.

**Trade Gossip.**

Armer & Weinshenk, San Francisco, have just issued their 20th Century New Material Catalogue. It consists of 745 pages, and the firm have endeavored to make it the most complete ever issued on the coast. It is being sent out to the trade on application.

The W. F. Doll Mfg. Co., 13 Maiden Lane, New York, who manufacture the Dewey and Hobson watches with cases made from the steel of the sunken battleship *Maine*, are turning out some novel chain charm pencils made of the same material. The pencils are in form miniature reproductions of a battleship's rifle cannon, and are called the "Dewey."

Geo. E. Darling, manufacturing jeweler, Providence, R. I., has sent to his patrons and customers a 32-page pamphlet, 8x11 inches, which is filled with fine half-tones of all the articles from pins to bracelets, ink stands to hair brushes, that he carries in sterling silver for the jewelry trade. So well are these illustrated that the jeweler can readily use the pamphlet with his customers, to take orders on those articles which he does not carry in stock.

The Fall stock of Alfred H. Smith & Co., importers of diamonds and precious stones, 182 Broadway, New York, now includes some of the richest goods ever imported in the wholesale jewelry trade. Among these may be mentioned some extraordinarily fine round pearls, running up as high as 50 grains and over. One pair which are worthy of especial note weigh

together over 100 grains and are perfectly matched. Their value is estimated at about \$20,000.

One of the latest and most interesting of electric clocks that has been offered to the jewelers in recent years is the "Grav-Elec" clock made by the Grav-Elec Clock Co., 177 Broadway, New York. There is a novelty and simplicity about the mechanism of this clock which appeal even to those uninitiated in horological and electrical mechanism, while the workmanship and material used in the construction are guaranteed to be of the best quality. This clock is, unlike others of its kind, without a main spring and differs from the regular electric clock in being run more directly by gravity than by electrical impulse. Dry batteries furnish the electricity which is used in the "Grav-Elec" for throwing the small gravity weight that drives the clock, the weight being thrown instantaneously and lightly to its gravitating position every 75 seconds. The quantity of electricity used is infinitesimal, and it is for this reason the company guarantee their clocks to run two years or more on one set of their non-polarizing batteries.

Probably the most complete and comprehensive catalogue that has ever been sent by a jobber to the retail jewelry trade is that just issued by the S. F. Myers Co., wholesale jewelers, 48-50 Maiden Lane, New York. This catalogue, which, like its predecessor, goes under the title of "The New York Jeweler," is "No. 100," and is the result of 20 years' experience in cat-

alogue making by this house. It is a large book of 720 pages, 8½x11 inches, is well printed and from the first leaf to the last is filled with exceptionally fine illustrations, wood cut and half-tone, of all the classes of articles carried by this firm. The book opens with some pages of general information for use of the trade, followed by an illustration showing Maiden Lane in front of the Myers building, and several sheets giving a glimpse in photo half-tones of various departments of this house. Then follows the catalogue proper, embracing watches, jewelry, and other goods so numerous that to give simply a list of the classifications would take more space than can be afforded in this column. Among the most prominent subjects, however, may be mentioned diamonds and diamond jewelry, which occupy 34 pages, gold jewelry taking 44 pages, plated jewelry 34 pages, silver plated ware 80 pages, solid silver ware 35 pages, watches 70 pages, optical goods 42 pages, badges and emblems 44 pages, bronze lamps, etc., 8 pages, camera and photographic supplies 20 pages, musical instruments of all kinds 48 pages, jewelers' findings 14 pages, cut glass ware five pages, and so on. Among the lines here contained which are not generally shown in catalogues of this kind are pianos. Stationery also occupies considerable space and, in fact, it may be briefly stated that within the covers of this book may be found classified, illustrated and described every sort or kind of article that the jeweler will ever have a call for during the life of his business.

**THE "VICTORIA" BRACELET (Patent Applied For.)**

Fastens with a snap. Fits any wrist. Made in three different sizes of links, chased or plain. Either ball or locket.

The Newest Thing in Bracelets. Most Stylish, Too.

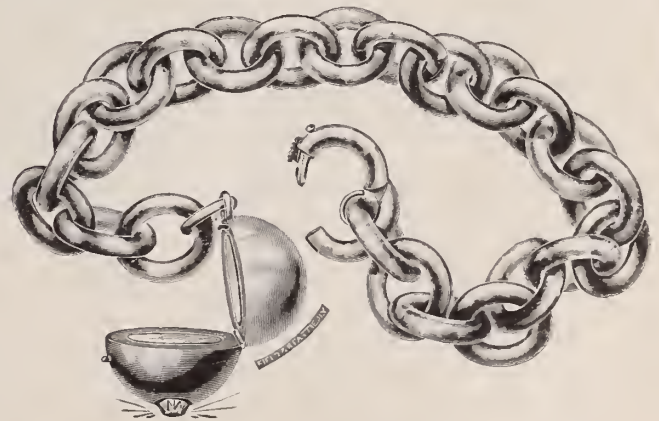

**DON'T LOSE SIGHT OF US**  
ON GOLD AND SILVER THIMBLES.  
YOU'LL BE THE LOSER IF YOU DO.

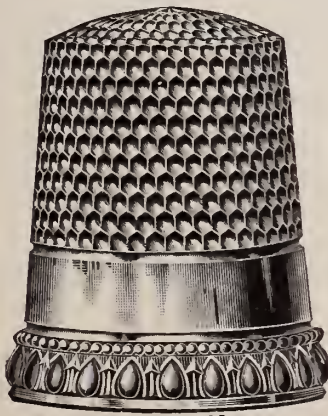

THE PRISCILLA

PAT. MAY 31, 98

Large number of other styles. Our Catalogue is at your call.

**SIMONS, BRO. & CO.,**

Silversmiths,

Thimble Makers, Manufacturing Jewelers,

PHILADELPHIA,  
616 Chestnut Street.

NEW YORK,  
19 Maiden Lane.  
41 Union Square.

CHICAGO,  
701 Columbus Building.

## OUR BUSINESS

is to serve our customers by helping them to make sales.

We seldom fail to secure an order when a prospective buyer looks over our lines.

Will you give us an opportunity to serve YOU?

**Henry Freund & Bro.**  
9, 11 & 13 Maiden Lane,  
NEW YORK.

"Sellers of Sellers."

### SILVER NOVELTIES

### SIMMONS & PAYE,

"The Souvenir House,"

129 Eddy St., Providence, R. I.,  
will mail to any jeweler on request a  
copy of their latest catalogue, illustrating  
manicure goods, toilet goods,  
and silver-mounted glass goods.

### The Delaware Ophthalmic College (INCORPORATED.)

We haven't time to say very much—business is the word. Send for our catalogue and compare it with others, and you will see for yourself where the best school is in the U. S. A. to get an optical education. Two courses, attendance and correspondence.

Dr. R. S. STEPHENS, President, DOVER, DEL.

The Buying Public Know and Appreciate a Good Thing. That's Why the

### CROWN 14 K. FILLED

Cases are Profitable for the  
Retail Jeweler to Handle.

### 25 YEARS' GUARANTEE.

#### CASH OFFERS.

If at any time you have offered to you by our customers any Jewelry containing diamonds, pearls or other precious stones, and you do not care to buy them yourself, send them to us and we will submit an IMMEDIATE CASH OFFER. Trade and Bank References If desired. Established 1880. Correspondence solicited.

CHARLES S. CROSSMAN & CO.,  
3 Maiden Lane, New York.

### Philadelphia.

Seamens & Struntz have bought out F. W. Betz, jeweler, Frankford.

G. H. Smith, Danville, Pa., was in town last week on his Fall visit to jobbers.

Charles Bash, jeweler and optician, has removed from 2311 to 2827 Germantown Ave.

H. Lay Beaven, Easton, Md., jeweler and optician, has sent out invitations for his marriage.

E. P. Zane, Christiana, Pa., was in town last week making extensive purchases for the Christmas trade.

James Freeman, jeweler, 807 Columbia Ave., is to be married shortly to Flora Levy, 512 S. 7th St.

Ralph Binder, of H. Muhr's Sons, was married last week to Miss Eleanor Woolery, of 3236 Chestnut St.

George W. Hamilton, optician, 1421 N. 10th St., was married last week to Mary R. Walker, of 1544 N. 13th St.

F. H. Smith, of the Geneva Optical Co., Chicago, was in town last week visiting the National Export Exposition.

James D. Hughes, wholesale jeweler, 730 Chestnut St., has started on a short trip through the south in his own interest.

William Wildemore, formerly of L. A. Scherr & Co., is now at the National Export Exposition as a representative of the Luxfer Prism Co.

Harry C. Ulmer, who has been in the employ of several local wholesale opticians and who is widely known, is now with D. V. Brown, 732 Sansom St.

Caroline Scherr and William Weglein, doing business as Scherr & Weglein at 2106 N. 17th St. as wholesale jewelers, have dissolved partnership. All bills are payable to Mr. Weglein.

Alexander Patterson, in charge of the exhibit of the Earle Silver Plate and Novelty Co. at the Exposition, reports that he has made several sales to the representatives of Brazil and Germany.

Mr. Midlen, of the Gorham Mfg. Co., made a study of the foreign samples department of the National Export Exposi-

tion while on a visit here last week. He was accompanied by his wife and sister.

The will of the late Daniel G. Langendorf, a well known jeweler of Camden, N. J., was admitted to probate by Surrogate West last week. The entire estate is left to his widow, Ellen H. Langendorf, who is named as the executrix.

J. C. Moncries, a demonstrating optician at the booth of the Philadelphia Optical Co., at the National Export Exposition, reported to the police Friday that he was on Wednesday night the victim of a brutal highway robbery committed at 33d and Sansom Sts.

### Minneapolis and St. Paul.

John A. Larson has resigned his position with Sisco & Beard and will go on the road for L. Finkelstein, St. Paul.

The store of Mauseth & Rob, Cameron Junction, Wis., is reported entered by burglars on the night of Oct. 24, who took watches and jewelry amounting to about \$100.

Zebulon Skinner, the young jeweler who is alleged to have helped himself liberally to the gems and valuables in the stock of Eustis Bros., Minneapolis, was in court last week, together with a number of others indicted by the grand jury. The charge against him is the embezzlement of a diamond bracelet worth \$250. To this charge young Skinner, who is alleged to have made a confession to the police, pleaded not guilty. The trial was set for Nov. 13, with bail at \$1,000. "Broker Jim" Brady, alleged to have been Skinner's handy man in disposing of the jewelry abstracted from Eustis Bros' store, was arraigned Oct. 26 on two charges of receiving stolen property. He pleaded not guilty and was held for trial in \$1,000 bail.

The death is reported of Frederick W. Wientage, Santa Fé, N. M.

Mahlon Craft, Bellaire, O., was recently succeeded by T. B. Phillips.

Wm. A. Ricard has succeeded Baker & Ricard, Toledo, O.

## EMPIRE COMBS. SIDE COMBS.

GOLD AND JEWELLED ORNAMENTED.

SPECIALTIES IN ROMAN WORK.

DAY, CLARK & Co.,

MAKERS OF FINE JEWELRY,

23 MAIDEN LANE, N. Y.



## Eliassof Bros. & Co.,

IMPORTERS AND JOBBERS OF

### DIAMONDS, WATCHES, JEWELRY,

9-11-13 Maiden Lane,

NEW YORK.

Materials, Tools and Optical Goods.

ALBANY OFFICE: 62 & 64 STATE STREET.

**Our Traveling**

**Representatives**



Traveling representatives may consider these columns open for the publication of any news or items of interest regarding themselves or their confreres.

The following traveling salesmen passed through Detroit, Mich., last week: E. W. Brannon, Jno. W. Reddall & Co.; A. J. Holly, Towle Mfg. Co.; F. M. Van Houten, Van Houten Bros. Jewelry Co.; Mr. Parker, Osmun-Parker Mfg. Co.; W. J. Carrow, Mandeville, Carrow &

Crane; Louis P. Cook, J. F. Fradley & Co.; Mr. Hodgins, Tarrant & Gismond; W. J. Lane, Geoffrey & Co.; H. A. Bliss, Kremetz & Co.; William Matschke, A. Joralemon & Son and F. & F. Felger; Henry Freund, Henry Freund & Bro.; D. P. Mygatt, Ferd. Fuchs & Bros.; H. H. Collard, A. F. Towle & Son Co.; G. H. Keller, Knothe Bros. and Jas. A. Flomerfelt & Co.; C. M. Dillon, Meriden Cutlery Co.; J. E. Simonson, A. J. Hedges & Co.; G. W. Bleecker, Martin, Copeland & Co.; D. R. Smith, Bates Bros. Co.; W. H. Gregory, Strobell & Crane.

Edwin Beekwith, the veteran optical traveler, is making his Fall trip through New York State.

Beni, Westervelt was registered at the Langwell, Elmira, N. Y., over last Sunday.

Eastern jobbers and manufacturers represented in the Twin Cities the past week were: Goldsmith Bros., by Mr. Speyer; Star Novelty Co., by T. Ryan; Carter, Qvarnstrom & Remington, by E. A. Remington.

Traveling men visiting Boston, Mass., the past week included: Fred Clarkson, Albert Lorsch &

Co.; M. Goodfriend, Goodfriend Bros.; J. Meyer, J. Heilbronn & S. Marchand; Leverett S. Lewis, Morris Prager & Co.; Mr. Beekwith, Joseph Fahys & Co.

Among the travelers in Kansas City, Mo., last week were: A. D. Engelsman, Goodfriend Bros.; J. Price, Byron L. Strasburger & Co.; I. W. Friedman; F. R. Horton, Carter, Hastings & Howe; F. E. Wallis, Thos. W. Adams & Co.

David J. Reagan, of Baldwin, Miller & Co., started on a long trip west Oct. 23, just 16 years since he started on his first trip for the same firm. J. E. Reagan has been visiting the trade in Indiana for the past two weeks. He reports business excellent—country dealers asking for high-grade goods and showing a keen desire to stock up early for the holidays.

Traveling men calling on Davenport, Ia., jewelers the past week were: Robert L. Robinson, Dennison Mfg. Co.; A. N. Brittan, M. A. Mead & Co.; A. E. Shader, Wendell Mfg. Co.; Max Noel, Stein & Ellbogen Co.; G. W. Kohn, Stein & Ellbogen Co.; M. Lighton, Simons, Bro. & Co.; LeRoy Cram, Benj. Allen & Co.; Louis Barnett, E. M. Bracher & Co.; Henry Klaus, S. Glikauf & Co.

During the last week in October the following traveling men called on jewelers in Indianapolis, Ind.: Mr. Heyman, Stern Bros. & Co.; C. L. Krugler, Jr., Champenois & Co.; John A. Abel, David Kaiser & Co.; F. D. Smith, N. E. Whiteside & Co.; Abel King, I. Emrich & Co.; W. H. Gregory, Strobell & Crane; Vic. L. Burgess, Kremetz & Co.; M. Kohn, Woodside Sterling Co.; John A. Keane, Ostby & Barton Co.; J. G. Trafton.

Among travelers in St. Louis, Mo., last week were: Harry Osborne, R. Wallace & Sons Mfg. Co.; Adolph Rosenthal; J. E. Alexander, for Frank W. Smith; A. E. Alexander, Wm. W. Hayden Co.; Mr. Kent, Wm. H. Ball & Co.; F. L. Pettee, Waterbury Clock Co.; E. A. Reed and J. F. Dean, Reed & Barton; Chas. B. Bartlett, Whiting Mfg. Co.; Abel King, I. Emrich & Co.; Otto Schneider, Hammel, Riglander & Co.; S. A. Goldsmith, Adolph Goldsmith & Son; Geo. W. White, Wm. S. Hicks' Sons; D. Untermeyer, Chas. Keller & Co.

Travelers in Pittsburgh, Pa., during the past

week were: J. M. Morrow, American Watch Case Co.; Mr. Heyman, Stern Bros. & Co.; George L. Paine, E. I. Franklin Co.; John A. Abel, David Kaiser & Co.; Mr. Sideman, Redlich & Co.; H. G. Nye, C. Rogers & Bros.; L. E. Fay, D. Wilcox & Co.; W. I. Schloss, Follmer, Clogg & Co.; Leo Goldsmith; M. Baum, Rothschild Bros.; J. R. Goodwin, Carter, Hastings & Howe; Frank J. Keller, the Keller Mfg. Co.; C. M. Dillon, Meriden Cutlery Co.; G. W. Bleecker, Martin, Copeland & Co.; F. D. Smith, N. E. Whiteside & Co.; E. C. McCarter, Lebkuecher & Co.; Isidor Lassner, Nordlinger & Mamluck; Gus W. Strandberg, Cheever, Tweedy & Co.; Frank W. Trewin, Keystone Watch Case Co.; M. J. Geary, S. Sternau & Co.; Charles C. Orcutt, Chester Billings & Son; Walter S. Noon, W. F. Cory & Bro.; A. A. Wood, Howard Sterling Co.; Mr. Kent, George O. Street & Sons and Wm. H. Ball & Co.

**Speculation as to the Loving Cup's Origin.**

AS to the origin of the loving cup *The Sun* surmises as follows:

"We think the 'loving cup' must have originated in Italy, where it happened not infrequently that hosts stabbed their guests or poisoned them at friendly banquets; but there is no definite history of the cup. The original loving cup had three handles. The host drank from it first, this act showing that the liquor in the cup was not poisoned; then, holding it by two of the handles, he passed it to his friend on the left. His two hands being occupied, he could not stab his friend; and as his friend took one handle in his right hand he would have been put to inconvenience to stab his host with his left hand. The cup did not prevent friendly assassination at dinner completely, but it made it much more inconvenient."



Poker Chip Box No. 287—M Z.



Bonbon Tray No. 256—O T.

If you desire, we can send you our catalogue illustrating the most beautiful line of

**CHRISTMAS GOODS**

ever put on the market.

**The Wave Crest Ware**

is the Newest, Snappiest and Best-Selling Line out.



Be sure to call at our  
New York Salesrooms,  
28 BARCLAY ST.

**C. F. MONROE CO.,** MANUFACTURERS OF  
**NOVELTIES FOR WEDDING AND HOLIDAY TRADE.**

Address all correspondence to Factory, **MERIDEN, CONN.**

THE EMPIRE WESTWARD TAKES ITS WAY

# WESTERN SUPPLEMENT

## THE JEWELERS' CIRCULAR

VOL. XXXIX.

NEW YORK, WEDNESDAY, NOVEMBER 1, 1899.

No. 14.

### Chicago Notes.

All communications in reference to the Chicago department of *The Jewelers' Circular*, addressed to Stephen Parlin, 1522 Lill Ave. (Telephone, Lake View 397), Chicago, will receive prompt attention.

F. M. Sproehnle, of Sproehnle & Co., has returned from a western trip.

Ed McKee, with the Geneva Optical Co., has recovered from a brief illness.

Mr. Eisenstadt, of the Eisenstadt Mfg. Co., St. Louis, Mo., was a visitor to the trade last week.

Geo. H. Cahoon, president of the Providence Optical Co., visited the optical trade here last week.

E. R. Gifford, Hannibal, Mo., was accompanied by his wife on his trip to Chicago last week.

S. J. Gardiner, who will soon begin business as an optician at San Diego, Cal., was here recently buying his opening stock.

W. J. Miller, manager of the Seth Thomas Clock Co.'s Chicago branch, has returned from a business trip to St. Louis.

The Chicago trade have been notified that Louis Oreckovsky, Duluth, Minn., has failed with a large indebtedness and no assets.

Frank R. Cross, many years traveler for the Columbus Watch Co. and now in business at Columbus, O., was here visiting old friends last week.

K. Hattori, president of the Guild of Clock and Watch Makers, of Tokyo, Japan, who is a delegate to the Export Exposition at Philadelphia, was in Chicago last week.

Geo. C. Gubbins, Chicago agent of the Illinois Watch Case Co., has returned from a trip in the northwest and will leave this week for Detroit, Cleveland, Cincinnati and Pittsburgh.

W. C. Abbott, manager of the Birmingham Optical Co., Birmingham, Ala., who will begin business in that city about Nov. 1, was here last week buying the company's opening stock.

P. J. Burroughs, jewelers' auctioneer, has returned from Dallas, Tex., where he held a successful sale. He will conduct a sale for A. K. Camp Co., Milwaukee, Wis., next week.

Mr. Snow, formerly with Charles Olson & Co., Minneapolis, Minn., has been appointed jewelry buyer of The Fair, succeeding Miss Munzer, who has gone with Siegel-Cooper Co., New York.

L. M. Bird, of Bird & Son, Aurora, Ill., called here last week. He reported the

condition of the crops in the great "cream and butter belt" was never better and the outlook for holiday trade was roseate.

W. W. Child, formerly in business at Jackson, Mich., visited old friends here last week. Mr. Child was called here to arrange for the settlement of the estate of his brother, E. L. Child, a prominent jeweler of Hamilton, Bermuda Islands, who died some time ago leaving a large estate.

A. B. Jones, who has been with E. B. Boynton, Stuart, Ia., over 12 years, and five years in the capacity of manager, was here last week buying for a new store he will open there about Nov. 1. Mr. Jones has been identified with the progressive interests of his town since boyhood, and has an enviable reputation for honesty and integrity.

Two indictments were last week voted by the Grand Jury against Fred Kauffman on charges of obtaining by false pretenses money and goods from Schlesinger & Mayer, and Edward A. Bazzett, a Madison St. jeweler. Alice J. Hall, who first figured in the case as Mrs. Kauffman, wife of Fred Kauffman, has deserted the prisoner and will testify against him.

The many friends of J. R. Davidson, manager of the Chicago branch of the T. Zurbrugg Co., surprised him last week at his home, 4549 Vincennes Ave., on the occasion of his 47th birthday. There is probably no person connected with the watch case trade of Chicago who is better known than Mr. Davidson, as he has been calling on the Chicago trade for over 33 years, 20 years of which have been spent in Chicago.

John H. Mertz, secretary of the Rich & Allen Co., and Miss Jessie M. Case were married Tuesday evening, Oct. 24, at the home of the bride on Calumet Ave. There are few of the younger men in the trade who are better known or more universally respected than Mr. Mertz. Mr. Mertz has been with the Rich & Allen Co. since the organization of the company and has been associated with his present partners since boyhood, being employed under Mr. Rich when he was manager of the Chicago office of Alfred H. Smith & Co.

The Jewelers' Bowling League will start on its career as an organization with five teams, each of the following houses being represented by a team: The Juergens & Andersen Co., Theo. Schrader & Co., Wendell & Co., Loftis Bros. & Co., and J. M. Reinke & Co. The regular schedule of games will begin in November. On ac-

count of the holiday rush of business no games will be played during December, the regular schedule being resumed next January. In a preliminary contest last week the J. M. Reinke & Co. team played the Theo. Schrader & Co. team, winning two games out of three.

Visitors in the city last week were: N. E. Benoit, Rockford, Ill.; J. C. Cleis, South Bend, Ind.; M. Heiner, Greenville, Miss.; Mr. Plain, Aurora, Ill.; August Bruder, Ft. Wayne, Ind.; Mr. Bierly, Oshkosh, Wis.; L. Weldon, Manistee, Mich.; Howard Williams, Delevan, Wis.; Wm. Egermann, Aurora, Ill.; J. F. Lindvall, Moline, Ill.; E. L. McDowell, Arkansas City, Kan.; Mr. Fenn, Prophetstown, Ill.; J. W. Hamilton, Danville, Ill.; M. Hainer, Macomb City, Miss.; Abbey Medland, Dallas, Tex.; S. W. Klase, Oconto, Wis.; F. C. Cook, Janesville, Wis.; Ed Dosh, Guthrie City, Ia.; W. H. Whitmore, Judson, Ind.; H. Mayman, Wauconda, Ill.; Wm. Rodger, Braceville, Ill.; Frank Thomas, Wyoming, Ia.; A. Combs, Paxton, Ill.; W. J. Ward, Gilman, Ia.; M. Montgomery, Windsor, Ill.; A. M. Henry, White Sulphur Springs, Mont.; D. C. Mayer, Kewaskum, Wis.; Chas. Sharp, Ripon, Wis.; E. South, Earlville, Ia.; Mr. Kuhn, Clifton, Ill.; Mr. Wise, St. Charles, Ill.; W. P. Yeoman, Waukegan, Ill.; Mr. Shortess, Traer, Ia., and C. N. Frazier, Norwalk, O.

### Pacific Northwest.

W. R. Doyle has opened a new jewelry store at Vancouver, Wash.

S. D. Stouffer, jeweler, recently of The Dalles, Ore., is in Waitsburg, Wash. where he will soon open a jewelry store.

A. Guibert, Waterville, Wash., has been at Seattle for the past week taking in the Exposition and attending to business matters in connection with his jewelry business.

H. D. Oliver, Lebanon, Ore., went to Portland last week to work in a jewelry store. He will probably return to Lebanon in the Spring and start a jewelry store at that place.

Fred E. White, jeweler, whose stock was burned out recently at Ontario, Ore., will go to the Sound and work for wages until he is able to again start up a business for himself.

Wm. F. Dielschneider, jeweler, McMinnville, Ore., has enlarged his storeroom and has added some new fixtures and large showcases which add greatly to the convenience of his store.

J. Zabranskay's new jewelry store, Seio, Ore., is about completed.

J. L. Cederstrom, of Portland, Ore., has opened a jewelry establishment at Sandy, Ore.

Sam Bayles, for some time engaged in the jewelry business in Spokane, Wash., has decided to discontinue about Jan. 1.

H. C. Van Ness, representing Durand & Co. and J. N. Provcnzano, interviewed the jewelers of Portland, Ore., the past week.

A. W. Hagey, jeweler, Seio, Ore., has just put in quite an addition to his stock, consisting of cloeks, watches and jewelry.

An addition is being built to W. T. Talbot's jewelry store, Oakesdale, Wash. Mr. Talbot will put in a new line of silver ware when his store is enlarged.

Martin Jewelry Co., of Walla Walla, Wash., have incorporated to do a jewelry business. Capital, \$4,000. Incorporators: C. D. Martin, M. Martin, K. D. Martin.

D. J. Kramer, manager of the Wm. Carpenter jewelry store, Salida, Col., has accepted a position as assistant manager of the jewelry store of Fredrick & Co. in Seattle, Wash.

The Daut Optical and Jewelry Co., The Dalles, Ore., Oct. 16 filed a petition in bankruptcy, in the United States court. The liabilities amount to \$1,695, and the assets to about \$900.

G. A. Webster, manufacturer of leather goods, Chicago, has issued his catalogue for 1900. The pages of the book are completely filled with half-tone cuts and presents a very handsome appearance.

### Pittsburgh.

John Wilkins, lately with Charles A. Wagner, is now in the employ of Leopold W. Vilsack & Co.

Mather Bros., New Castle, Pa., are remodeling their store, adding new stock and handsome fixtures.

McLean Pollock, formerly with A. E. Siedle, of the East End, is now with H. C. Cubbison, New Castle, Pa.

Fred Laban, a well known jeweler of Toronto, O., has removed to Steubenville, O., to re-engage in business.

William Henry Harrison, Jr., recently arrived in the household of William Harrison, of Geo. B. Barrett & Co.

Theodore Ingert, material man for Goddard, Hill & Co., left last week for the south, where he may go into business.

E. F. Weckerle, a manufacturing jeweler of Fifth Ave., has sold out to his son, Frank Weckerle, Jr. Mr. Weckerle will engage in other business.

One of the events of the week was the retirement from the jewelry business of Jas. R. Reed, one of the pioneers in the trade in Pittsburgh. Mr. Reed sold out his interest to his brother, George Reed, and his nephew, James Allison Reed, who will conduct the business, paying all the old debts, under the old firm name of J. R. Reed & Co. J. R. Reed will devote much of his time to travel.

Coming close upon the Biggs failure and the Reed retirement are two rumors to the effect that a new jobbing house will be opened and the consolidation of two or three of the leading retailers in the city

who propose taking an entire building and opening a model store. The trade is extremely active this Fall, and if rumors have any foundation there will be several sensations promulgated before Jan. 1.

Edward J. Bubb, Jr., administrator of the estate of Rebecca J. Bubb, issued a writ of foreign attachment against Edward J. Bubb, Sr., both manufacturing jewelers of this city, to recover \$9,680.77. The Southwest Pennsylvania pipe lines, the National Transit Co. and others are summoned as garnishees. Mrs. Bubb, now deceased, inherited, in 1882, a tract of land in Hampton township from her father, George Summerville. The land in late years yielded oil and gas, and it is alleged that she made a contract by which she was to receive certain royalties, but that E. J. Bubb, Sr., her husband, collected the money and that the same belongs to the estate of Mrs. Bubb.

Out-of-town jewelers in the city last week were: W. J. McKinney, East Liverpool, O.; F. B. McKinley, Washington, Pa.; F. H. Hayes, Washington, Pa.; G. A. Boss, McKec's Rocks, Pa.; Roy & Anderson, Braddock, Pa.; Wm. Hunt, Uniontown, Pa.; Wm. Heckman, Meadville, Pa.; Henry Hartman, Wapakoncta, O.; A. R. Fleming, Wilkinsburg, Pa.; A. J. Miller, Massilon, O.; John Linnenbrink, Roehester, Pa.; John Z. Simpson, Blairsville, Pa.; Mrs. L. C. Brehm, West Newton, Pa.; H. H. Weylman, Kittanning, Pa.; H. C. Morrison, Mt. Pleasant, Pa.; L. Furtwangler, Greensburg, Pa.; Thos. Maher, Clarksville, Pa.; Geo. V. Brady, Washington, Pa.; F. Worrell, Washington, Pa.; Jacob Wolf, Suterville, Pa.

## Over 100,000 Now in Use.

# Improved O Size Atlas Movements

EVERY MOVEMENT  
GUARANTEED.



Nickel Damask.  
Price, \$8.00,  
Catalogue List.

New issue now in NICKEL.

American manufacture.

Lever Set Hunting.

The best American Movement ever  
produced for the money.

SALE UNPRECEDENTED.

Write your Jobber for Samples.

EVERY MOVEMENT  
GUARANTEED.



Gilt.  
Price, \$7.50,  
Catalogue List.

# ATLAS WATCH COMPANY,

9 MAIDEN LANE, NEW YORK.

103 STATE STREET, CHICAGO, ILL.

The door of August C. Gies's jewelry store, 52 Frankstown Ave., was found open at 1.30 on the morning of Oct. 26 by a policeman. Mr. Gies, who resides above the store, was aroused and took part in the investigation of the store, but nothing was missing.

Mayor W. J. Diehl received a letter Oct. 25 from George Windhurst, jeweler, Baltimore, Md., enclosing a piece of one-dollar Pittsburgh scrip issued by the city in January, 1845, which he wished cashed. The Mayor will forward the sender a dollar bill and likely keep the scrip as a relic.

George Teplitz, a watchmaker at Samuel Maltinsky's jewelry store, Braddock, was seriously burned Oct. 23 by spilling alcohol upon his clothes, which immediately caught fire from a lighted taper. He ran to the street, where the blaze was extinguished by a man who wrapped his overcoat around Teplitz. The latter was burned on the face, breast and hands.

### Pacific Coast Notes.

George E. Bangle has opened a jewelry establishment at Vallejo, Cal.

B. H. Annin and H. H. Hall will shortly open a jewelry, watch making and optical store at Pasadena, Cal.

Emil Zander, optician, Los Angeles, Cal., died in that city recently. The deceased was a native of Germany, 33 years of age.

William Goeggel, formerly of Woodland, Cal., is a member of a new San Francisco jewelry company who have been incorporated with a capital stock of \$100,000.

The jewelry stock of Keshishyan & Grant, Vallejo, Cal., was damaged by the explosion of a gasoline stove a few mornings ago. The loss is fully covered by insurance.

Anderson Bros., Auburn, Cal., have made several improvements in their store. They have added several feet of new show cases and counters, recovered the floor with linoleum and papered the store room.

### Kansas City.

A. Mueler has opened a new store at Ellis, Kan.

M. O. Patrick has opened a new store at Hartshorn, I. T.

A. J. Baum, jeweler and furnishing goods dealer, has sold real estate valued at \$1,100.

Wm. Woolard, Olathe, Kan., has generally remodeled his store and bought new fixtures.

Wm. McLoud, manager of the Columbian Optical Co., this city, has returned from a trip to Omaha.

A. R. Blackstone, formerly a watchmaker in Jefferson City, Mo., has come to Kansas City and is in the employ of the Meyer Jewelry Co.

Louis J. Bohl, who has been in the employ of the manufacturing jewelers of Chicago for several years, has accepted a position with the Meyer Jewelry Co., this city, where he was formerly employed.

Lapp & Flershem, Chicago, issued last week their 1900 catalogue. It is a similar volume to its predecessors, but, of course, containing the newest goods. It is a book of 512 pages, 12x9 inches, bound in cloth stamped with the name of the recipient, the name of the issuers appearing in it nowhere.

### Cincinnati.

The police are holding a man giving his name as Joe Murphy for investigation. He had a number of "phony" rings in his possession when arrested.

Sig. Strauss is on the road with a fine line of diamond novelties. He went out this Fall with two large new trunks of new goods, and will stay out until Dec. 1.

The Neuhaus Mfg. Co. have received the order for the Cornell University class pin, having submitted but one design. This is a great card for this firm. The order is for fobs and pins.

The Bell Watch Case Co. have effected arrangements with a prominent London and New York firm for exclusive representation in Australia for the Bell watch cases. The contract was mailed last week.

Bene, Lindenberg & Co. have imported a large line of cutlery, silver novelties and bric-à-brac, which is expected next month for the holiday trade. Jewelers should send for some samples at once, before the goods are all gone.

Herman & Loeb have added to their stock an attractive line of silver novelties in plush and leather cases suitable for wedding or Christmas presents, which they are offering to the trade at prices that will sell every article.

The Jewelers' Co. turned out last week a magnificent line of cluster rings for the holiday trade. Louis J. Hendricks, manager, is on the road making a personal visit to the trade and taking orders for their jewelry specialties.

R. H. Dilley, Cambridge, O.; John Selbert, Frankfort, Ky.; W. R. Jackson and wife, Franklin, Ky.; C. A. Williams, Terre Haute, Ind.; A. Axman, Frankfort, Ky.; J. Hofman, Springfield, were among the trade buying goods here last week.

Joseph Noterman & Co. have perhaps the largest diamond order work trade in this section, and the increase this year has been notable. Their new pendants and miniature brooches, diamond mounted, are among the most popular articles on the market.

The optical department of Oskamp, Noltling & Co. is one of the features this house are making a success of this year. They manufacture many of their goods and have a large optical plant. They supply the trade at large with everything in this line and fill orders promptly and reasonably.

Frohman, Wise & Newman are making a specialty of fine ebony novelties and carry an elegant line for the holiday trade. B. S. Newman has returned from a trip through the south and reports a fine trade. He said all the jewelers were fixing up their stores and getting ready for attractive displays for the Christmas season.

The Homan Silver Plate Co. have issued an elegant catalogue, the first they have gotten up in 20 years, and it is profusely illustrated with the many lines they turn out. It has a superb cover and is altogether a desirable reference book on plated ware. As they have only a short edition those inquiring first will be served first.

Albert Bros. have been keeping their force at work until 9 o'clock every evening to fill orders promptly. They have about the largest stock of watches and clocks in town, and while they have turned

down many orders they are still going slow on movement orders. They claim they have lost numerous sales of watch cases because they could not get the movements.

The Wadsworth Watch Case Co. are making the prettiest cases this year they ever made, and adding daily new designs. Their Christmas goods are very elaborate, especially in the 0 and 6 sizes. Colored gold decorations enter largely into the artistic work, and the workmanship is unespecially in the 0 and 6 sizes. Colored other year in the history of the firm, and the excellence of their goods has achieved for them a wide and growing popularity east and west.

Judge Davis decided a few days ago that the law which provides that a person may sue another before any magistrate in the county is unconstitutional. It was in the case of the American Watch and Jewelry Co. against Charles Freund. He was sued before Magistrate Fisher, at Norwood, though he is a resident of the city, and an attachment was levied against his property. The decision is against the practice of bringing suit before a magistrate in some distant part of the county just to put the defendant to a great deal of expense.

### St. Louis.

F. W. Drostin has returned from a week's fishing trip on the Gasconade River.

Wm. Gotsch has removed to 3221 Easton Ave. He was formerly located at Grand and Easton Aves.

Morris Eisenstadt, of the Eisenstadt Mfg. Co., is in Chicago. Sam Eisenstadt, of the same firm, has just returned from New York.

Elegant plate-glass windows and other improvements are being placed in the store southeast corner 6th and Locust Sts., to be occupied this week by Hess & Culbertson.

Henry Estinghausen, of the Attleboro Jewelry Co., will leave on Nov. 4 for an extended business trip to the Hawaiian and Philippine Islands, also to Japan and Hong Kong.

Out-of-town jewelers here last week were: J. M. Earp, Lamar, Mo.; Wm. Brazeale, Pacific, Mo.; L. V. Saunier, Bonnot's Mills, Mo.; H. W. Foerste, Okawville, Ill.; J. J. Lysakowski, Lebanon, Ill.

Articles of incorporation were filed Oct. 26 by the Sempire Clock Co., of this city; capital stock, all paid in, \$200,000. The company will manufacture electro-gravity clocks. The stockholders are: Ralph H. Orthwein, 825 shares; Max R. Orthwein, 375 shares; Bernard J. Ryan, 500 shares; John C. Vulsen, De Lacy Chandler, Wm. J. Orthwein, W. E. Orthwein, H. M. Beers and R. E. Bluhrhardt, each 50 shares. The company have been in business a number of years at the corner of 4th and Locust Sts., and with formal incorporation and largely increased capital, expect to do a large business. The new stockholders are among the best known business men and capitalists of the city.

Herman L. Stricker, Calvert, Tex., has been succeeded by Herman L. Stricker & Co.



# Sig. Strauss & Co.,

**WATCHES,  
DIAMONDS,  
JEWELRY,**

CAREW BUILDING,  
CINCINNATI, O.

EDWARD ALBERT,  
LOUIS H. ALBERT.

## ALBERT BROTHERS,

Wholesale Dealers in

**Watches,  
Diamonds,  
Jewelry,  
Clocks,**

Tools, Material, Silverware.

N. E. COR.  
FOURTH AND PLUM STREETS,  
CINCINNATI, O.

**FROHMAN & CO.,  
Wholesale Jewelers  
CINCINNATI, O.**

**Ebony Goods,                    Are  
Silver Novelties,                Our  
  Specialties.**

Write us for prices and get a  
profitable line for the Holidays.

## FREE.

One of our Patent Metal Novelty Show  
Cases with every order for our  
5c. and 10c. COLLAR BUTTONS.

Write for Particulars.

**COLDBERG BROS.,  
CINCINNATI, O.**

# THE WADSWORTH GOLD-FILLED CASES.



Factory and General Office:  
**Newport, Ky.**

New York Office:  
11 John Street.

Chicago Office:  
Columbus Building.

Send for illustrated catalogue.

Dealers desiring electrotypes for advertising can  
obtain them free of cost.

## OSKAMP, NOLTING & CO., CINCINNATI, OHIO.

**Wholesale Jewelers,  
Diamond Importers,  
Optical Manufacturers.**

Send for Holiday line. Largest stock and biggest variety to select  
from. All the novelties of the season. Headquarters for optical goods.

## BENE, LINDENBERG & CO., CINCINNATI, OHIO.

**Wholesale Jewelers,  
Importers of Diamonds,  
Headquarters for Watches,  
Imported and Silver Novelties.**

Write for Prices  
and Samples of  
HOLIDAY GOODS.

**HERMAN & LOEB, Wholesale Jewelers,  
208 & 209 Johnston Building, Cincinnati, O.**

## DIAMOND IMPORTERS.

Jobbers of all kinds of American Movements and Cases,  
Jewelry, Clocks and Silver Novelties.

GIVE US A TRIAL ORDER.

WHOLESALE ONLY.

**Columbus, O.**

The board of trade of this city is having an invitation made of gold which will be sent to Admiral Dewey, asking him to visit Columbus some time in the future.

O. S. Hofman, of the Hofman Supply Co., was in New York the latter part of last week and the first of this buying goods and looking after other business in connection with his firm.

The jewelry store of Adam Border, New Washington, was burglarized on the night of Oct. 24, and a large amount of valuable goods taken. At this time no trace of the thieves has been found.

The Jewelers' Manufacturing Co., of Cleveland, have been incorporated with a capital of \$30,000 for the purpose of manufacturing, importing and jobbing jewelry. The incorporators are Herman Goldsmith, Nathan Auspach, E. Goldsmith, J. S. Russell and Elmer W. Waite.

A man giving the name of Albert Hoffman has been arrested in Cincinnati on suspicion, and on his person was found a check for \$22.50 signed with the name of Frank F. Bonnet, this city, and made payable to Frank Seidel. Mr. Bonnet says he does not know the man and never signed a check of that kind.

Hon. Philip Bruck, of the old Columbus Watch Co., has filed his report and also his resignation as receiver of the company. He gives as a reason for this action that he has so much other business that he cannot give this work the proper attention. As receiver Mr. Bruck has on hand \$3,042.13, and his receipts were \$13,790.59. The disbursements were \$10,833.21. The resignation was accepted and A. W. Krumm was appointed under a bond, which he gave.

**Detroit.**

A big down town jewelry house declare that so far their sales are 25 per cent better than last year and 40 per cent better than two years ago.

Fred Pitcher, formerly a jeweler at Benton Harbor, Mich., has returned after a three years' absence, and will open a store at 128 Pipestone St.

The county building committee last week decided to install an electrical system in the new county building now nearing completion. The rivals were the Self-Winding Clock Co. and the Johnson Electric Service Co., a fight between the electrical clock and the pneumatic clock. The vote stood four to five against both propositions at first, but the board of supervisors, to which the matter was referred, made the decision. The cost of the electrical system will be \$4,687 and of the pneumatic \$4,570.

**Indianapolis.**

Oct. 28 Enrique C. Miller left for Mexico to visit his father.

Charles R. Kluger, Huntingburg, Ind., was here last week buying his Christmas stock.

J. W. Hudson, Fortville, Ind., is greatly improved in health since his extended trip through the west.

**Omaha.**

M. Hastings, Arcadia, Neb., was in Omaha last week.

Winfield J. Taylor, Sidney, Ia., was a buyer in the city recently.

Mr. Cummings, of J. C. Cummings & Co., Attleboro, Mass., was in Omaha last week.

M. Hano, of Phillip Hano & Co., New York, called on the jewelry trade last week.

Will A. Wood, Burlington, Ia., has been engaged as salesman by J. C. Huteson, optician.

J. W. Howard, proprietor of a large jewelry and optical establishment in Hastings, Neb., was in the city last week purchasing goods.

E. P. Shaw, formerly in the wholesale jewelry department of Marshall Field's, Chicago, has been engaged as salesman by Mawhinny & Holliday, this city.

James Matthews, who has been with Mawhinny & Holliday and their predecessor, C. S. Raymond, was married last Wednesday evening to Miss Sophia Miller, of Council Bluffs.

George T. Marsh, Atlantic, Ia., called upon the wholesale dealers last week. J. Bellamy, Arapahoe, Neb., purchased goods in Omaha last week. George Frater, Louisville, Neb., was in the city last Thursday purchasing goods.

J. C. Huteson returned from the east last Tuesday. While in Boston he attended the wedding of his brother, T. J. Huteson, to Miss Isabel Moore, niece of Gov. Ames. T. J. Huteson traveled in the jewelry business for 12 years, and is well known to the trade. He and his bride will pass the Winter in Egypt.

It is impossible to tell just how much was stolen from the Columbian Optical Co. store, two weeks ago. Mr. Agnew, the manager, hears of articles every now and then which he identifies by the company's name upon them. Many of the articles have been recovered, but of those known to be missing still are a pearl opera glass and a telescope, worth between \$40 and \$50.

**Georgian STERLING SILVER.**

In Complete Table Service—



COFFEE SPOON.

French Gray Finish.

**TOWLE** MANUFACTURING CO.,  
CHICAGO. NEWBURYPORT, MASS.



**Earrings in Fashion.**

[The Sun.]

THE long continued reports that earrings were coming into fashion again have become more convincing as they have increased in number and volume, probably because constant repetition gives the appearance of unimpeachable fact, but now they have bobbed up again with many more evidences of truth. Anyway earrings are seen oftener than they were a year ago, but most of them are of the kind which screw into the ear.

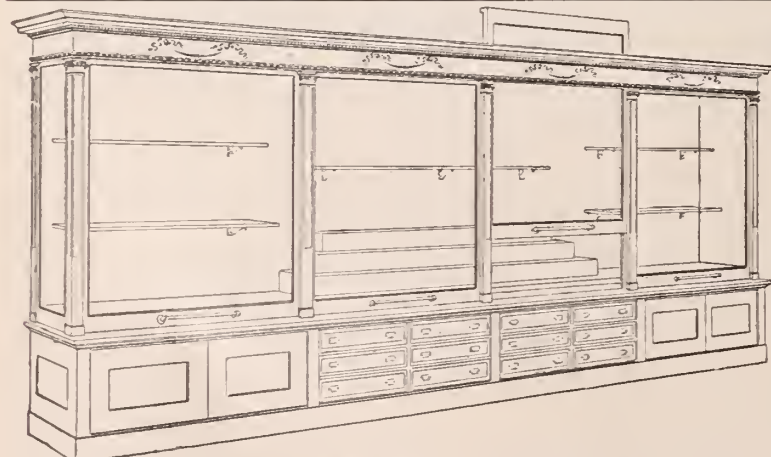

Prices cheerfully furnished upon application. Mention The Jewelers' Circular.

**Alexander H. Revell & Co.**

431 FIFTH AVE., CHICAGO, ILL.  
253 BROADWAY, NEW YORK.

MANUFACTURERS OF

**High Grade Jewelry Fixtures.**

We make a specialty of manufacturing strictly high grade jewelry fixtures, wall cases, tray cases, show cases, tables, window cases, etc. Our cases are of the most modern type in design and construction, with latest improvements for electric lights, etc., and we guarantee our work to be first class in every particular. If in the market for fixtures, give us a chance to quote price. Address Factory direct, 431 Fifth Ave., Chicago.

WRITE FOR OUR No. 8 CATALOGUE.

**Canada Notes.**

A. Lapointe, Ottawa, Ont., has sold out. John Thornton, jeweler, New Glasgow, N. S., has opened in business.

Lapierre & Coursolles, jewelers, etc., have started business at Ottawa.

Rod Curry, jeweler, has removed from Fort Hawkesbury, N. S., to Sydney, N. S. Alexander Gibson, jeweler, Hanover, Ont., has given a chattel mortgage to A. B. Kaiser for \$386.

Edgar Hurdle, jeweler, Glencoe, Ont., and wife have given a renewal chattel mortgage to S. W. Fawsett for \$390.

Among the thousand Canadian men who have volunteered for service in the Transvaal to assist Great Britain is Alex. Hannaford, jeweler, aged 23, whose birthplace is Montreal.

An attempted burglary was made on Tuesday night, Oct. 24, on the jewelry store of A. J. Allen & Co., 102 St. Lawrence St., Montreal. The thieves broke a pane of glass, but were evidently disturbed in their work. The damages were slight.

The Council of the Montreal Board of Trade has addressed the City Council upon the subject of the number of small burglaries that have recently taken place in Montreal and the neighborhood, several of which have been perpetrated upon jewelry stores.

The employes of the rolled plate department of the Montreal Watch Case Co. assembled at the Montreal Drill Hall on the night of Oct. 25 to bid one of their fellow employes, James Duncan, good-by on the eve of his departure with the Montreal Transvaal company of volunteers.

Robbers entered the store of Octave Beauregard, jeweler and watchmaker, St. Madeline, Que., during the night of Oct. 24 and stole about \$400 worth of watches, rings and other jewelry while he was sleeping. He only noticed his loss when he got up in the morning, although he was sleeping in the next room to the store.

**Connecticut.**

Charles H. Tibbits returned to Wallingford Oct. 24 from Chicago.

J. Allsopp will open a jewelry store in Derby about Nov. 1.

Fred H. Hill, the Danbury jeweler, who is now making his home in Attleboro, Mass., is on a trip to Denver, Col.

The engagement is announced of Miss Pauline Mayer, daughter of the late David Mayer, diamond merchant, of Hartford, and Julius Rosenfield, of New York.

After Jan. 1 the Barbour Silver Co., Hartford, who are absorbed in the International Silver Co., will occupy the old Meriden Silver Plate Co. factory, Meriden. The Barbour Silver Co. have been employing from 200 to 300 persons.

Representatives of the C. B. Barker Mfg. Co., 56 Warren St., New York, who will probably locate in Milford, were in town last week getting water rates and arranging other matters in the way of repairs necessary for occupancy. The deal for the purchase of the factory is almost closed.

The engine of the Middletown Silver Co., Middletown, is being put in position. This new company will occupy the second story of the old Hubbard factory on Warwick St. They hope to be able to com-

mence work next week. At first they will make only a few designs in hollow ware, but will gradually increase the number.

The fire in the factory of the E. T. Burgess Cut Glass Co., Middletown, reported in the last issue of THE CIRCULAR, did damage estimated at \$3,000. The Burgess company were insured for \$13,500. This will more than cover the loss sustained. Most of the stock of glass ware, cut and uncut, was cracked and destroyed. The fire had gained such headway that the glass was badly heated when the water was thrown in, and the result was the cracking of the glass.

To a Diamond.

THOU thing of beauty, with a soul of fire!  
 In some Eastern harem long ago  
 Didst thou adorn the favorite's hand of snow?  
 Or did some dark Egyptian queen desire  
 Thy brilliant flash along her stringed lyre,  
 While her low lidded gaze swept proud and slow  
 The valley where the Nile's deep waters flow?  
 Or did some harlot of thy beauty tire?

It matters not. Swart queens have come and gone;  
 Harlots have triumphed—and have been forgot;  
 The rose of power has withered on the vine!  
 Yet oh, most beautiful, it is thy lot  
 In radiant splendor to go flashing on—  
 In beauty deathless and in light divine!  
 —Ella Higginson in *Woman's Home Companion*.

**LINKS.**

Just a Word Regarding Our

**Anniversary Line of 10K. Link Buttons.**

Every Die New this Season, and  
 Every Pattern a Work of Art.

We guarantee them not to break and will give a  
 new pair in exchange for any pair that  
 does not give satisfaction.

**JOHN T. MAURAN MFG. CO.**

NEW YORK OFFICE,  
 3 MAIDEN LANE.

FACTORY,  
 PROVIDENCE, R. I.



**High Grade  
 Ebony Ware.**

Artistically silver mounted and plain. Mountings unique in design. Superbly finished. Send for catalogue.

**FREEMAN J. FINLEY,**

Maker of Sterling Initials,  
 Importer of Ebony Goods,

**866 BROADWAY, NEW YORK.**

We also have a large and well-equipped engraving department. Monograms, Inscriptions, Crests and Coats of Arms.

### News Gleanings.

M. C. Meeker is a new jeweler in Farmington, Minn.

L. A. Holdener, Greenville, Ill., will occupy new quarters soon.

J. A. McClelland is fitting up a watch repair shop in Piedmont, Mo.

H. W. Hartley & Co. have opened a jewelry store in Bedford, Pa.

C. Ditto, a jeweler from Davey, Neb., has opened a shop in Ashland, Neb.

Herman Unger & Son, Muskegon, Mich., have moved to 97 W. Western Ave.

Theo. F. Rude, Cuba, N. Y., has had his store handsomely redecorated and papered.

Work was discontinued on the Moore

garnet mines, at Gore Mountain, N. Y., last week.

J. Johansen, jeweler, has purchased the stock of jewelry of D. Thomson, Brigham, Utah.

A new plate glass front is being put in at J. C. Klaholt's jewelry store, Springfield, Ill.

Harry Bullard, Wellsville, N. Y., has had a handsome new oak wall case placed in his store.

Haeley & Gavin, Bolivar, N. Y., have had a new natural gas furnace placed in their store.

J. W. Smith, Hornellsville, N. Y., has added a handsome new oak wall case to his store furniture.

T. H. Denkhoff, of Dubuque, Ia., has

opened a jewelry business in Briggs's drug store, New Hampton, Ia.

The jewelry store of Woodson & Clawson, Clarence, Mo., has been moved to the Farmers' Cash Store, that town.

John H. Starbuck, formerly of New London, Conn., is very ill with typhoid fever at his home, 12 Circuit Ave., Worcester, Mass.

L. D. Robinson, who has been in the jewelry business for 25 years in Washington, Ia., has sold his stock to Earle Lewis and C. S. Lemmon.

Jos. Linz & Bros.' new store, Dallas, Tex., which they classify as "the finest jewelry establishment in the world," was thrown open to the public Oct. 21 in three "grand receptions."

The stockholders of the new Standard Silver Plating Co., Akron, O., organized Oct. 23 by electing Hugo Schumacher, president; Max Schumacher, general manager, secretary and treasurer; C. A. Williams, superintendent. The company will manufacture coffin hardware.

C. O. Upper & Co., 287 Genesee St., Buffalo, N. Y., were robbed of 15 diamond rings valued at \$1,000 on Saturday, Oct. 21. Four men entered the store between 1 and 2 o'clock p. m. and asked to look at some diamond rings. Two trays of them were placed on the show case for their inspection, and during the talk which followed the rings were taken and the men soon left without making a purchase.

William L. Fenwick, watchmaker and jeweler, 12 W. Falls St., Niagara Falls, N. Y., who was arrested a few days ago upon complaint of I. Traub, another local jeweler, charged with having disposed of goods of considerable value, the property of the complainant, by selling them in Canada, has been discharged in police court. Traub did not appear at the adjourned examination, and Fenwick was released and the \$500 bonds he was under canceled.

Hanna & Eroë, jewelers, New Castle, Pa., will, with M. Loy Hanna, who has the musical department, occupy all of the three stories of their building. This move places the firm in possession of the premises occupied by J. C. Hanna more than 50 years. Under the new arrangement each department will have a competent manager, and the store will be arranged and fitted up with that idea in mind. W. J. Eroë will continue to manage the business part of the firm, W. P. Hanna will have charge of the books and finances, and M. Loy Hanna will have exclusive charge of the musical department.

J. Manning, jeweler, who left Plain City, O., a few weeks ago, was thought to have been found last week. An article appearing in the *State Journal* attracted the eyes of some of the citizens of Plain City. It was to the effect that the dead body of a man had been found near Canal Dover, the description answering that of Manning. Mrs. Manning, hearing of the rumors, telegraphed at once for a description of the body. She received an answer and was informed that the man weighed in the neighborhood of 185 pounds, had black curly hair and mustache, with a deep scar on forehead, which does not answer to that of her husband.

## Secession Art Designs

IN UMBRELLA HANDLES.....

### Our Fall Lines Include

**Gun Metal**, inlaid with precious stones.

**Gun Metal**, inlaid with gold, Secession Designs.

**Gun Metal**, with enameled Secession portraits of celebrated beauties.

**Gun Metal**, bonbonnière heads with mirrors in hinged covers.



### The Latest Novelties in

**Limoges Enamels** on Sterling Silver, Modern Art Designs.

**Dresden Ware.**

**Burnt Ivory**, with gold and silver trimmings.

**Iridescent Pearl.**

**Crocidilite; Tortoise Shell** in knotted and carved effects; **Lapis Lazuli**, &c.

## FOLLMER, CLOGG & CO.,

PHILADELPHIA: 1031 Chestnut St.  
SAN FRANCISCO: 7 and 9 Battery St.  
FACTORY: LANCASTER, PA.

Makers of Fine Umbrellas for the Jewelry Trade.  
414 BROADWAY, NEW YORK.

## CARD CASES... Ladies' or Gentlemen's.

### Sterling Mounted.

SPECIAL LINES FOR JEWELERS.



**C. F. RUMPP & SONS,**  
FINE LEATHER GOODS,

Fifth and Cherry Streets, - Philadelphia.

New York Salesroom: 621 Broadway.



Send for Illustrated Catalogue...

John New will open a jewelry store in Winthrop, Ia.

Will Hotchkiss will open a jewelry store in Wautoma, Wis.

A. A. Wise has removed from McLouth, Kan., to Peabody, Kan.

John Kirkpatrick has opened a jewelry shop in Winchester, Kan.

K. H. Lambertson, Winthrop, Minn., is advertising his business for sale.

The jewelry store of P. Lindenstruth, Pensacola, Fla., is being remodeled.

E. J. Gilbert, Fonda, N. Y., has removed his stock to the Hees block.

William Hermann, jeweler, Vanderbilt, Pa., is seeking to locate in Ulingo, O.

W. L. D. Hagan, jeweler, is now located in Pearson's drug store, Newton, Kan.

E. A. Griffin, Oakland, Neb., has been looking for a location in Bancroft, Neb.

P. H. Nefflen is opening a jewelry store under the Brady house, Lonaconing, Md.

Daniel Ballmer, jeweler and optician, has opened a jewelry store in Cozad, Neb.

L. P. Gribble has opened a jewelry store in the Pacific Express office, Columbia, Mo.

H. T. Segerstrom is remodeling the interior of his jewelry store in Ironwood, Mich.

W. Woolfolk, Centralia, Mo., has been in Bunceton, Mo., whence he left for a trip through Texas.

C. A. Brown this week will open a jewelry store in the Maxwell building, Appleton, Wis.

Geo. J. Boitnott has removed from Collins, Ia., to Maxwell, Ia., where he will go into the jewelry business.

Frank E. Murtha, of Stamford, N. Y., in his bankruptcy petition states liabilities aggregating about \$2,500.

W. L. Ayers, Columbus Junction, Ia., has now his new store in good working order. It is an attractive establishment.

W. Allen, formerly with Andrew Clark, Port Chester, N. Y., will open a jewelry store in the Ryan block, Westchester Ave., after Nov. 1.

The jewelry stock and fixtures of J. H. Weston's store, Vestal, N. Y., have been purchased by H. L. Whitney and added to his stock in Union, N. Y.

Walter Rodman, of Slater, Mo., a practical jeweler, has purchased the jewelry stock in Tibbett's drug store, Armour, S. D., and will conduct the business.

Chas. H. Schaefer, who for eight years has been watchmaker for Olin V. Neal, Parkersburg, W. Va., has engaged in business for himself at 328 Juliana St., that city.

Two handsome silver fire trumpets adorned the window of J. J. Capron's jewelry store, Armenia, N. Y., the past week. They belonged to Armenia Hose Co. No. 1.

L. G. Call purchased the bankrupt stock of jewelry, cases, etc., of W. S. Pipes, Waynesburg, Pa. Mr. Call will continue the business. He has been to St. Louis and Chicago to stock up.

J. W. Eckart, New Iberia, La., whose place of business was destroyed by fire Oct. 10, as already announced in THE CIRCULAR, issued under date of Oct. 16 a circular announcing that he had adjusted his insurance, secured new and commodious quarters, and resumed business.

We are not content with **Keeping Abreast of the Times,**  
But are always **Ahead of the Times.**

Our September business was 25 per cent larger than any previous month, but we filled 90 per cent of the orders the day they were received.

**Unexcelled Facilities,**  
**Unexcelled Productions,** and  
**Unexcelled Service in Filling Our Orders**

are the three great reasons why we are obliged to run nights to keep **AHEAD OF THE DEMAND** for our goods.

**GEO. W. DOVER,**  
**Jewelers' Findings,**  
**Cup, Strip and Tubular Settings, Ornaments, etc.**

235 EDDY STREET, PROVIDENCE, R. I.

FRANK F. WOOLLEY, New York Representative,  
Astor House.



RINGS,  
BROOCHES,  
LOCKETS,  
SCARF PINS,  
THIMBLES,  
DIAMOND  
MOUNTINGS  
....AND....  
DIAMOND  
JEWELRY.

33-43 Gold Street,  
NEW YORK.  
149 State Street,  
CHICAGO.  
518 Market Street,  
SAN FRANCISCO.

C. E. Conklin, Canute, Kan., has sold real estate valued at \$1,000.

The Knefly Jewelry Co., Dallas, Tex., have been sued for a debt amounting to \$40.

G. W. Ellis, jeweler, Stewartville, Minn., has added a stock of notions to his business.

John Kite, Wymore, Neb., has moved his jewelry store to another location in that town.

C. W. Okley, Browning, Mo., is reporting the arrival of a pair of twins at his home.

Chase Huffman, jeweler, Springfield, O., has returned from Chicago, where he was in attendance at the Chicago Optical College.

Robert A. Douglas, North Platte, Neb.,

has sold out his entire jewelry stock to H. Dixon.

J. A. Harstad has succeeded to the entire jewelry business of Harstad & Gilbertson, Hillsboro, N. Dak.

The store room to be occupied by W. H. Ricaby, St. Joseph, Mich., is undergoing radical renovation.

Max Menein has established a jewelry store at 198 Market St., Paterson, N. J. Mr. Menein was with Elliot & Platt for five years.

Ezra F. Bowman, 12 E. Chestnut St., Lancaster, Pa., has assumed the agency in that section of the Waltham Clock Co., Waltham, Mass.

Fred Butler, formerly located in Hopkins, Mo., where he was engaged in the jewelry business, has accepted a position

as watchmaker for Alfred P. Hall, Blockton, Ia.

L. Steinbrenner is the successor of Herman & Co., opticians, Wilkes-Barre, Pa. He is located at T. C. Parker's jewelry store, 22 Public Square.

Frank Clark, of Clark & Engle, Wilkes-Barre, Pa., left, Oct. 25, for New York to make his holiday purchases in diamonds, jewelry, silver ware, etc.

W. E. McMillan, formerly engaged in the jewelry business in Des Moines, Ia., has gone to Kansas City, where he takes a position with Cady & Olmstead.

R. N. Allison, Grove City, Pa., will remove his jewelry store from the Covert & Johnston building to the new Reynolds building Nov. 1. He has leased the building for five years.

T. A. Holbrook, manufacturing jeweler, Fairfax, Mo., has just put in a complete retail line, and W. M. Freeman has taken charge of the retail business and watchmaking department.

Wesley Downs, who conducted a jewelry store and pawn office in Altoona, Pa., for several years, has opened a shooting gallery on Washington St., opposite the B. & O. passenger depot, Johnstown, Pa.

Between the hours of 4 and 6 o'clock A. M., Oct. 20, a thief broke a large plate glass window in William T. Warth's jewelry and drygoods store, 373 Hudson Ave., Rochester, N. Y. About a dozen rings and some collars and several combs, all valued at about \$25, were stolen from the window.

J. S. Lang & Son, who have been conducting a drug business in Coffeyville, Kan., for a number of years, have just returned to that city from a jewelry buying trip, and report that they have stocked up quite extensively in the jewelry line and will operate a combination store.

John Hess, who has been connected with the G. Scherzinger jewelry store, Fond du Lac, Wis., several years, has resigned with a view of engaging in the jewelry business independently. Mr. Hess has leased a portion of the Bazaar building, and expects to occupy it with a new stock of jewelry about Nov. 10.

The wholesale jewelry firm of Taylor & Son, formerly located in the Phelps bank building, Binghamton, N. Y., have been succeeded by Taylor & Lowell, who are now installed on the second floor of the Binghamton Savings bank building, Collier St. The firm are composed of Charles E. Taylor and Mason Lowell, and the business of the old concern has been increased by the addition of an optical plant. The traveling force has been increased by the addition of L. S. Beckwith, formerly with a New York jobbing house.

Burglars broke into the store of Gillette Brothers, Auburn, N. Y., a few nights ago. A rear window was used as a means for entering the store. The goods taken included one open face fancy dial New York Standard filled case watch, two H. C. gents' filled watches, one dust proof silver watch, one H. C. silver Waltham watch, two silver watches, 50 gents' watch chains, six black fob chains, four dozen charms and lockets, one dozen lodge pins, one pair of garter buckles with initial "M," four or five gold pens with pearl handles, one pair of pearl opera glasses, one pair of fancy opera glasses and a few plated fob charms.

**NOV. 1.**

**DEC. 24.**

Less than two months left to do your Christmas buying. Therefore, act promptly and order at once your needs in

**"Old Standard"**

**Simmons Chains**

**(New Patterns, New Ideas)**

**AND**

**Cyrano Chains, Locketts, Seals,  
and Marlowe Bracelets.**

**AT JOBBERS.**

**R. F. SIMMONS & Co.**

**Factory and Main Office:      New York Salesroom:**  
**Attleboro, Mass.                      9-13 Maiden Lane.**

**The Latest Patents.**

ISSUE OF OCT. 24, 1899.

**635,369. THIMBLE.** FRANCIS C. BOWEN, Madison, N. J., assignor to the Consolidated Safety Pin Company, Bloomfield, N. J. Filed July 13, 1899. Serial No. 723,668. (No model.)



A thimble of frusto-conical shape formed integral with a lower plain portion and an upper portion divided into alternating grooves and elevations, which are respectively concave and convex, of uniform area and continuous with each other, the grooves situated in a line within the surface of the thimble, and the elevations situated in a line coincident with the surface thereof, whereby both the grooves and elevations are adapted for effective presentation to the sewing needle.

**635,380. ELECTROPLATING APPARATUS.** RANSOM E. GOODRICH, New Britain, Conn. Filed May 17, 1899. Serial No. 717,132. (No model.)

**635,427. SCARF PIN.** DONALD R. CORBIN, New York, N. Y. Filed May 12, 1899. Serial No. 716,521. (No model.)



A scarf pin or ornament consisting of a design, a sleeve secured to the reverse side of said design, said sleeve projecting at an angle to the plane of the design, and a detachable pin adapted to pass through the sleeve and project beyond or to the lower portion of the design at the front of the face thereof.

**635,443. OCULIST'S TESTING FRAME.** EMIL B. MEYROWITZ, Ridgefield, N. J. Filed July 1, 1898. Serial No. 684,926. (No model.)

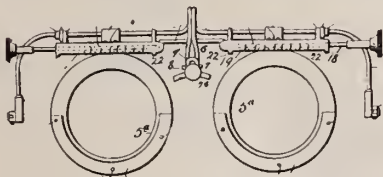

A testing or trial frame, the body of which is formed of wire bent to form loops lateral to the length of the wire, which loops form journals for the adjustable parts of the testing frame.

**635,444. OPTICIAN'S TESTING FRAME.** EMIL B. MEYROWITZ and FERDINAND BUCHHOP, New York, N. Y. Filed Nov. 14, 1898. Serial No. 696,358. (No model.)

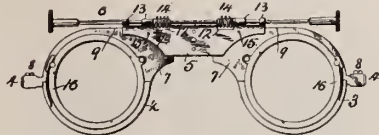

In a testing frame a bridge or yoke composed of a piece of metal folded or united along its medial line so as to form side pieces whose inner surfaces form an extended way, and means for adjusting the eye pieces back and forth in and along said way.

**635,472. PHOTOGRAPHIC OBJECTIVE.** CARL P. GOERZ and EMIL VON HOEGH, Friedenau, Germany. Filed July 2, 1898. Serial No. 685,045. (No model.)

**635,473. THREE-LENS SYSTEM FOR PHOTOGRAPHIC PURPOSES.** CARL P. GOERZ and EMIL VON HOEGH, Friedenau, Germany. Filed March 1, 1899. Serial No. 707,420. (No model.)

**635,494. EYEGLASSES AND SPECTACLES.** DAVID H. LUDLOW, Easton, Pa. Filed June 25, 1897. Serial No. 642,224. (No model.)

In combination—a pair of lenses—clamping posts connected with said lenses—a saddle bridge formed with depending loops and upwardly extending free extremities of which are connected with the clamping posts—and the inner face of which from its crest to the bights of its loops is adapted to lie



in unbroken continuous contact with the wearer's nose—and nose rests.

**635,508. EYEGLASSES.** EMILE E. PEQUEGNAT, St. Louis, Mich. Filed June 27, 1899. Serial No. 722,058. (No model.)



The combination with lenses, of the pliable or bendable plates, each having a long arm and a short arm arranged in a common plane and spaced edgewise with relation one to the other, the short arm having at its unconfined end a right-angularly-disposed shank which is made fast with one lens at a point below the short arm, a bow spring fastened to the long arms of said plates, and pad-plates also secured to said long arms of the plates.

**635,510. FINGER RING.** GAIGE M. SAUNDERS, Waterloo, Iowa. Filed Sept. 24, 1898. Serial No. 691,776. (No model.)



The herein described finger ring composed of a single piece of wire *A* whose ends are bent back to form loops *b* and *b'* each embracing the shank of the other, and the return wires after making said shanks being coiled closely as at *a* and *a'* around the body wire *A* beyond said loops, a subsidiary eye *c* formed in and projecting laterally from one of said loops, and a bangle *B* attached to said eye.

**635,611. WATCH GUARD OR PROTECTOR.** WILLIAM S. SUTTON, Belvidere, Ill. Filed June 11, 1898. Serial No. 683,206. (No model.)

A device of the class described comprising a pair of hooks fulcrumed between their ends and provided at the inner edges of their lower portions with prongs normally extending inward, said

hooks having outwardly-projecting upper portions, and links connected with the upper portions of the hooks and designed to be attached to a watch chain and adapted when there is a strain on the latter to throw the engaging portions of the hooks



outward to prevent a watch from being removed from a pocket.

**635,645. NOSE GUARD FOR EYEGLASSES.** CHARLES BILLINGTON, Attleboro, Mass. Filed March 8, 1898. Serial No. 708,210. (No model.)

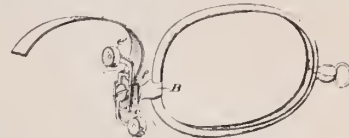

In a nose guard for glasses, the combination of suitable lens frames, a bow spring, pairs of pad carriers, each carrier being separate from the others and consisting of a shank portion having a pad at one end, blocks constructed to support a pair of pad carriers and to permit their longitudinal adjustment independent of each other, devices adapted to clamp the said bow spring, pad carriers, blocks and frames together, the frames and blocks being rotatively adjustable with respect to each other.

**635,700. FOUNTAIN PEN.** GEORGE S. PARKER, Janesville, Wis. Filed June 30, 1899. Serial No. 722,366. (No model.)



A fountain pen comprising a barrel *a* having a pin or projection *a'* therein, a nozzle *b* adapted to fit within the mouth of the barrel, said nozzle being cut away on its inner end to form an extension *b'*, the said extension being notched or cut away at *b''* to engage the pin or projection in the barrel, whereby the nozzle is removably held in place, a pen and feeder mounted in said nozzle, said feeder having ink ducts opening into the barrel and adapted to convey the ink to the point of the pen, and means for conveying ink from the side of the barrel to the ink ducts in said feeder.

**635,711. JEWELRY EXHIBITOR.** CHARLES H. BUXTON, Boston, Mass., assignor to the Dennison Mfg. Company, same place. Filed July 5, 1899. Serial No. 722,894. (No model.)

A jewelry exhibitor comprising a display card provided with an opening to receive the article to be displayed, a casing much smaller than the said card and arranged at the back of and carried by said card merely to hold the article the face of which is displayed through said opening at the face of said card, and a supporting member to

# The "Cherub"

## PRIVISE

No. 8.

KENDRICK & DAVIS,

LEBANON, N. H.

AMERICAN TOOLS ARE THE CHEAPEST

Because they are the Best and Parts can always be duplicated quickly.

FOR SALE BY ALL JOBBERS. SEND FOR OUR NEW ILLUSTRATED CATALOGUE.

support said card in elevated display position whereby the general effect of the device as ordi-



narly viewed by an intending purchaser is that of a display card.  
**635,729. ESCAPEMENT. HENRY GANNEY,**

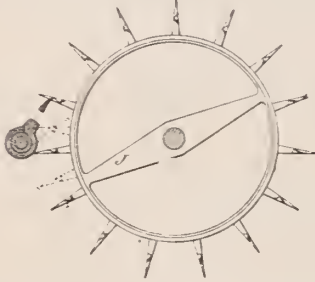

New York, N. Y. Filed Feb. 17, 1899. Serial No. 705,830. (No model.)

The combination in an escapement mechanism of an escape wheel having a plurality of teeth, a balance roller having a notch with which the said teeth are adapted to engage, a plurality of auxiliary impulse teeth, a pallet carried with the said roller and adapted to engage with the said auxiliary impulse teeth, said pallet being arranged with a clearance or recess between its outer extremity and its axis whereby it may pass clear of the impulse teeth when returning or when not desired to engage therewith.

**DESIGN 31,705. BRUSH BACK OR SIMILAR ARTICLE. FRANK J. DIACONT, Providence,**



R. I., assignor to the H. H. Curtis Company, North Attleboro, Mass. Filed Sept. 27, 1899. Serial No. 731,868. Term of patent 3½ years.

T. B. McArthur, formerly in business at Bay City, Northville, Gladwin, Pinconning and Grayling, Mich., has opened a jewelry store in Elsie, Mich.

**EXPIRED PATENTS.**

[The following list of recently expired patents of interest to the trade is furnished by R. W. Bishop, Patent Attorney, Washington, D. C. A copy of any patent may be had from him for 10 cents.]

*Issued Oct. 24, 1882.*

- 266,265. WATCH MOVEMENT BOX. L. W. ARNOLD,** Chicago, Ill., assignor of two-fifths to J. L. Hutchinson, same place.
  - 266,278. MAKING ORNAMENTAL CHAINS. WILLIAM EDGE,** Newark, N. J.
  - 266,324. RING GAGE. C. F. SMITH,** Vine-land, N. J.
  - 266,396. BALANCE-SPRING HOLDER. THEODORE SMITH and M. P. MCKOON,** Franklin, N. Y.
  - 266,436. EYEGLASSES AND SPECTACLES. J. M. CRAWFORD,** Philadelphia, Pa.
  - 266,473. COMBINED CANE AND OPERA GLASS. SAMUEL HELFGOTT,** New York, N. Y.
  - 266,475. FOUNTAIN PEN. S. W. HIGGINS,** St. Louis, Mo.
  - 266,518. TIME DETECTOR. G. F. RANSON,** Cleveland, O.
- Designs issued Oct. 25, 1892.*
- 21,919. SPOON. A. H. ULLRICH,** Evanston, Ill.
  - 21,924. MATCH BOX. SIMON ZINN,** New York, N. Y.



Price,  
**\$12.00** Per Gross.

To be had of  
 all Jobbers.

# MAINSPRINGS

Made for all  
 American Watches.

Price,  
**\$12.00** Per Gross.

**WINDSOR SPRINGS** are made from **WINDSOR STEEL** which has been tested and found to be perfect. Windsor steel produces a more perfect mainspring than any other steel, and has been compared with over fifty other makes.

If you want a **GOOD MAINSPRING** that will give you as little trouble one month as another, and with ordinary care never break; that will run the same in quality year in and year out, we advise trying the **"WINDSOR."**





# OPTICAL DEPARTMENT.

Note.—From this week till further notice this department will be run as usual, viz.: every other week.

## Encyclopedia-Dictionary and

### Reference Handbook of the Ophthalmic Sciences.

Copyrighted 1898, by The Jewelers' Circular Pub. Co

By R. H. KNOWLES, M.D.

[Commenced in issue of July 6, 1898.—Continued from  
page 53, Oct. 18, 1899.]

#### PART XXXVIII.

**Koroscopy** (*ko-ros-co-py*). [Greek, *koros* = pupil + *skopeo* = I see.] An objective method of examination of the eyes by means of the skiascope or shadow test. Synonyms: **Umbrascopy**, **Keratascopy**, **Pupilloscopy**, **Fundus reflex test**, **Skiascopy** and **Shadow test**.

#### L.

**L.** The Greek letter lambda expresses a wave length. The letters **W L**, the initial letters for Wave Length, mean the same.

**Lachrymal** (*lach'-rym-al*). [Latin, *lacryma* = tear.] That which relates to the tears. Synonyms: **Lacrymal**; **Lacrimonal**.

**Lacrima** (*lac'-rim-a*). [Latin, *lacryma* = tear.] The secretions of the lacrymal gland.

**Lacrimonal** (*lac'-rim-al*). [Latin, *lacryma* = tear.] The property of the tears.

**Lacryma** (*lac'-rym-a*). [Latin, *lacryma* = tear.] The lacrymal fluid; the tears. Synonym: **Lacrima**.

**Lacrymal** (*lac'-rym-al*). [Latin, *lacryma* = tear.] That which has reference to the gland which secretes the tears and the duct and channel through which the tears are conveyed. The lacrymal apparatus are all of the anatomical parts which deal with the tears. The lacrymal canals or the canaliculi lead from the puncta lacrymalis through the lacrymal sac to the nasal duct, through which the tears are permitted to escape. There are two of these canals, one located in the upper lid and the other in the lower lid, above and below the caruncular lacrymalia. They have the appearance of two elevated pimples which in a healthy state lie down upon the eyeball, permitting of the absorption of the tears. The lacrymal ducts lead from the gland to the palpebral conjunctiva. These ducts, fourteen in number, lie parallel in an oblique plane of about 45° downward and inward. There are several instruments employed for the purpose of entering the lacrymal canal. The lacrymal probe is used for dilating the canaliculi after it has been slit. There are about twelve sizes, each employed in turn in the course of treatment for distending these parts. The lacrymal style is used for distending the nasal duct and remains *in situ* for a shorter or longer period.

**Lacrymation** (*lac'-rim a'-tion*) [Latin, *lacryma* = tear.] An excess of tears, so

that they flow over upon the cheeks either as a symptom of a disease, or while weeping.

**Lacrymatome** (*lac-rym'-at-ome*). [Latin, *lacryma* = tear.] A sharp instrument employed for the purpose of slitting the canaliculus and plunging into the nasal duct.

**Lacrymotomy** (*lac-rym-ot'-o-my*). [Latin, *lacryma* = tear + *tome* = a cut.] The operation of slitting a stricture of the canaliculus or slitting other parts of the lacrymal channel.

**Lagophthalmia** (*lag-oph-thal'-mi-a*). [Greek, *lagos* = a hare + *ophthalmos* = the eye.] A condition in which the lids cannot close even during the hours of sleep. Taken from the false idea that the hare never closes his eyes. That which pertains to Lagophthalmia is called **Lagophthalmic**. Synonym: **Lagophthalmos**.

**Lagophthalmos** (*lag-oph-thal'-mos*). [Greek, *lagos* = a hare + *ophthalmos* = the eye.] That state in which the eyelids never close.

**Lamellar** (*lam-el'-lar*). [Latin, *lamella* = a plate or layer.] That which resembles a thin plate. A thin membrane. A lamellar cataract is one of the incomplete varieties of partial opacities of the crystalline lens. This kind of cataract occurs in children who appear to suffer from myopia. Lenses, however, will not compensate for the diminution of vision. The pupils are deep seated and gray in color. The opacity, when seen, is often mistaken for the nuclear varieties but by means of the condensing lens the layers of the opaque crystalline lens appear distinct and clearly defined, so that there can be no mistake after making an examination by means of the oblique illumination. The indirect method of ophthalmoscopy reveals a crystalline lens having a gray-like appearance with dark dots around a red ring or zone. The two eyes are affected alike and this variety of cataract occurs in children who give a history of having spasms during the period of their infancy. The children are always neurotic and the family history is always bad as to diseases which attach themselves to the nervous system. The progress of the disease is very rapid, so that a few months time will cover the period during which lamellar cataract will develop from its initial stage until the time for its removal. The treatment for the removal of this kind of cataract depends upon the gradual absorption of the lens substance by the operation of needling or dissection, which permits the aqueous humor to enter the lens by means of an incision made through the capsule. Several such operations are necessary before the opacity disappears. Sometimes it is thought best to break up the lens substance and finally remove the same by means of Bowman's syringe, the nozzle of which is allowed to dip down into the mass and to gently withdraw the substance into the syringe. This is called the suction method for the removal of a lamellar cataract.

**Lamina** (*lam'-in-a*). [Latin, *lamina* = plate or layer.] A layer consisting of a flat, thin

membrane. Three of the five layers of the cornea (Valk) are called laminae. The anterior lamina or Bowman's membrane is the second layer of the cornea, and the fourth layer (Valk) is called the posterior lamina. The posterior elastic lamina is Descemet's membrane, sometimes called the posterior epithelial layer (Valk). The vitreous lamina is a term given to the internal surface of the choroid coat.

**Laminaria probe** (*lam-in-a'-ri-a probe*). [Latin, *lamina* = plate + *probare* = to demonstrate or prove.] An exploratory probe employed for dilating the canaliculi, including the nasal duct.

(To be continued.)

#### Interesting Meeting of New York State Opticians.

SYRACUSE, N. Y., Oct. 21.—The October meeting of the New York State Association of Opticians was held in the assembly room of The Yates on Wednesday afternoon, Oct. 18, at 4 o'clock. The meeting was called to order by the president, Fred Hamilton, and Secretary Golder, of Seneca Falls, read the minutes of the previous meeting, which were approved. A communication was read from John J. Smith, of Albany, requesting information in regard to the Association and its workings and an application blank. Dr. A. E. Johnson, 301 University block, Syracuse, also desired an application blank.

In behalf of the special committee appointed to arrange for a meeting to be held at Geneva, Mr. Swart, of Auburn, reported that the committee had made definite arrangements for a meeting to be held in Geneva on the third Wednesday in January. An elaborate programme will be prepared and there will be a banquet and visits to the Geneva Optical Co.'s and Standard Optical Co.'s works. Under the head of new business various communications were read, including a letter from A. Jay Cross, president of the Optical Society of the State of New York. Under the head of unfinished business it was carried that Secretary Golder be empowered to secure a new lot of certificates of membership in place of those lost in transit.

President Hamilton then read a pithy paper of admonition and encouragement containing many valuable suggestions and much good advice, which was followed by remarks by F. L. Swart and A. W. Golder. O. E. Ward, of Phoenix, moved that a vote of thanks be given the president for his able suggestions. It was carried. Mr. Swart moved that the president appoint a committee of three to prepare a programme for the next five months. This was carried. It was moved and seconded that the president be chairman of the programme committee, which honor he accepted. The committee as appointed are Fred Hamilton, of Syracuse; Miss Viola Russell, of Weedsport, and G. N. Luckey, of Baldwinsville. John Wagner, of Utica, called the attention of the members present to glasses of his invention, called "Wagner's Improved," which called forth a general discussion as to their merits. The meeting then took on an informal air, and numerous questions pertaining to optical subjects were asked, discussed and an-

swered, following which the meeting adjourned until Nov. 15. Hereafter the meetings of the Association will be held at 501 and 502 Dillaye block, S. Salina St.

Members of the Association present included F. L. Swart, of Auburn; A. W. Golder, of Seneca Falls; E. O. Ward, of Phoenix; Miss Viola Russell, of Weedsport; Edwin Wilcox, of Fulton; A. H. Rose, of Skaneateles; John Wagner, of Utica; G. N. Luckey, of Baldwinsville; W. H. S. Weatherbee, of Clyde, and Fred Hamilton, of Syracuse. Frank E. Robbins, of Elmira, and B. S. Hopkins, of Penn Yan, both members of the Association, have joined the well filled ranks of the benedicts since its last meeting.

E. B. Allen, Laclede, Mo., is out of business.

### Workshop Notes.

**New Polish for Nickel.**—According to the *Farben Zeitung*, calcic hydrate, i.e., the residue remaining from the generation of acetylene, is an excellent polishing medium for nickeled parts. It may be employed like white chalk, but excels the latter in polishing capacity. Only the dry powder, however, should be employed.

**Selenium** is now used for coloring glass. Rose tinted glass is made by adding selenium directly to the ingredients in the melting pot. By mixing first with cadmium sulphide, orange-red is produced. This process is stated not to require the reheating of the glass and its immersion in the coloring mixture, as in the ordinary process of making red glass.

**Uninflammable Celluloid.**—According to Asselot, dissolve 25 parts of ordinary celluloidine in 250 parts of acetone and add a solution of 50 grammes of magnesium chloride in 150 grammes of alcohol, until a paste results, which occurs with a proportion of about 100 parts of the former solution to 20 parts of the latter solution. This paste is carefully mixed and worked through, then dried, and gives an absolutely incombustible material.

**Varnish for Aluminium.**—The following is a process giving a special varnish for aluminium, but it may also be employed for other metals, giving a coating unalterable and indestructible by water or atmospheric influences: Dissolve, preferably in an enameled vessel, 100 parts, by weight, of gum-lac in 300 of liquid ammonia. Heat on the water bath for about one hour and cool. The aluminium to be covered with this varnish is carefully cleaned in potash, and, having applied the varnish, the article is placed in a stove, where it is heated, during a certain time, at a suitable temperature (about 300° C.).

**Hardening of Steel.**—For hardening purposes in general the use of black soap cannot be too much recommended. The piece, after having been lightly heated, is plunged into the soap, whereby it becomes surrounded with a covering which protects it against possible overheating. It is heated again to the desired degree and hardened as usual, whatever the hardening bath may consist of. If the piece is well hardened, the layer formed by the soap becomes detached upon the slightest contact and the piece appears very white, the polished portion being only a little dull. The precaution must be taken to clean in pure water, then in alcohol, or merely in alcohol alone. Without this precaution, the piece would have a tendency to rust promptly. Every workman who has tried this process will use no other, as it affords a saving of time and a facility in working. If the steel is to be very hard, a small quantity of prussiate of potash may be added to the soap.—*Science Pratique.*

## SUSSFELD, LORSCH & CO.



Ask your jobber for  
our lines of Optical  
Goods.

### MIRRORS,

Magnifying and plain,  
in large variety.

### Magnifiers.

### Compasses.

## OPERA and FIELD GLASSES.

37 & 39 Maiden Lane, New York.



Established 1879.

*S. & A. Borgzinner,*  
Manufacturers & Importers,  
82 & 84 Nassau St.  
New York.

### To Distinguish Genuine Diamonds.

[*Le Diamant.*]

THE counterfeiting of the diamond has been developed to such an extent that the experiments of M. Margot, of the University of Geneva, with aluminium are of special interest. His method is simple. If characters or marks of any kind are drawn with an aluminium pencil on glass, porcelain or any substance containing silex, the marks cannot be erased by rubbing, however energetic the friction, and even acids will not cause them to disappear entirely, unless the surface is entirely freed from greasy matter, which can be accomplished by rubbing with whiting and passing a moistened cloth over the surface at the time of writing. So, in order to distinguish the true diamond from the false, it is only necessary to wipe the stone carefully and trace a line on it with an aluminium pencil and then rub it briskly with a moistened cloth. If the line continues visible, the stone is surely false. If, on the contrary, the stone is a true diamond, the line will disappear without leaving a trace, and without injury to the stone.

## MATTERS IN JEWELRY STOREKEEPING.

That this department shall prove mutually beneficial to our readers, it is desirable that the members of the trade generally communicate with THE CIRCULAR regarding any advantageous device or plan that they are utilizing in connection with their business.

### Best Dressed Windows Among the Retail Jewelers.

#### Series II. No. XIII.

*NOTE:—We inaugurated with the issue of May 3, 1899, the second series of characteristic retail jewelers' windows. The first series consisted of illustrations and descriptions of more than 100 different displays, extending over a period of 8 years. We desire any jeweler who thinks his window is interesting or calculated to serve as a lesson to his brother jewelers, to send to us a photograph of such window for illustration under this department.*

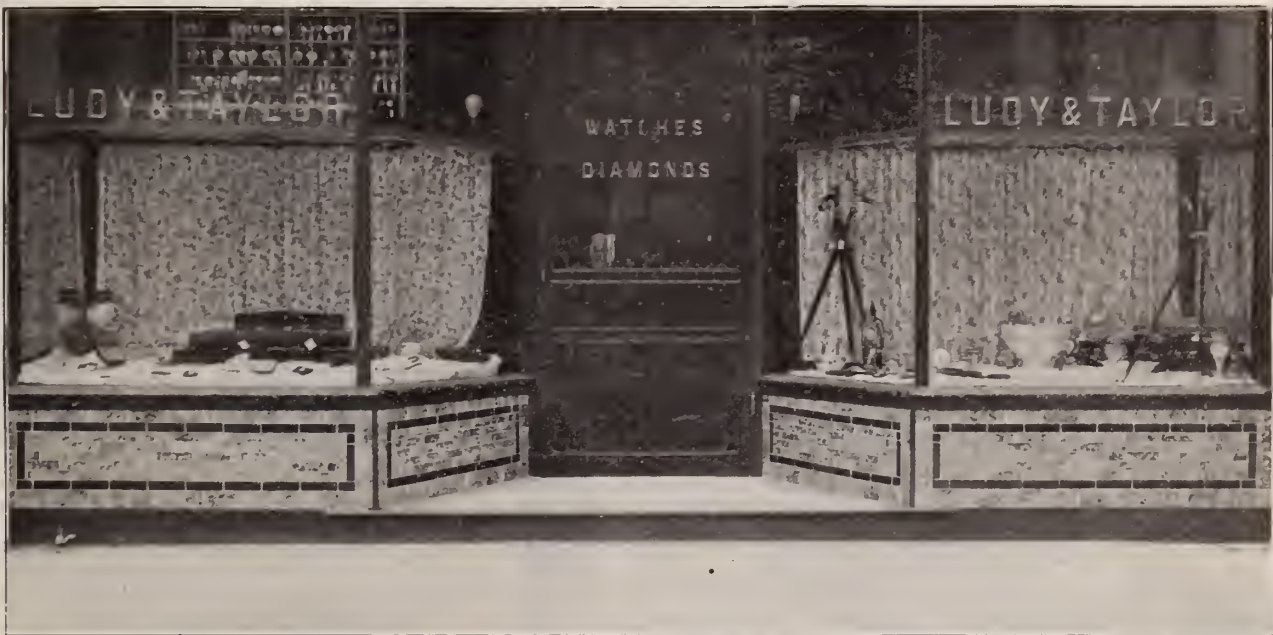

THE CHASTE AND ARTISTIC DOUBLE WINDOW OF LUDY & TAYLOR, CEDAR RAPIDS, IOWA.

TRAVELING salesmen who cover the middle west report the store of Ludy & Taylor, Cedar Rapids, Ia., as being one of the most attractive in that territory. The half tone herewith, while pretty enough, hardly does justice to the original. The bottom of the windows is usually covered with white silk. Fancy silk curtains form the background. While there is nothing elaborate about the display it is constantly attractive by reason of its perfect cleanliness, its brilliancy and its diversified arrangement of goods. On the wall of each window is a plate mirror which alternately reflects the displays for apparently the distance of a block. Irregularly shaped step platforms covered with black velvet are set here and there and are admirably adapted for the showing of watches and fine gold goods. The windows are lighted by incandescent electric lights hidden from view as much as possible. The interior of Ludy & Taylor's store is an object lesson to retailers, and will be treated in a subsequent issue of THE CIRCULAR.

#### Window Displays as Advertisements.

WE have repeatedly commented upon the important part the window display fills in any retail jewelry store. Those who have experienced the profitable results of artistic window dressing are amazed at the want of appreciation of this method of advertising displayed by many dealers who adopt many other methods of advertising. Store keepers who are in good positions complain of the heavy rents they are called upon to pay, but they overlook the fact that part

of that expense is incurred for the opportunity given them to display their goods to the great number of likely buyers. Rent is based on other considerations besides the size of the shop and the stock room. The facilities for advantageous display are always taken into account by landlords of premises or lessees of ground to build them on. If store keepers choose to keep on paying rent for this means of advertising their wares and neglect to take advantage of it they are sure to consider their rent high. Many store keepers have all sorts of excuses—we cannot call

them reasons—for neglecting their window display. They appear to look upon the window as the means for lighting the store and then for stocking as many goods as they can get into it without impeding the light. Light is very well in its way and very essential for showing goods, but the modern store window is much too valuable to be used solely for this purpose. If the only means of daylight in the shop is through the front window, far better use artificial light than neglect one of the best advertising mediums.

#### Window Display Truths.

“ATTRACTIVE window displays sell goods” is a trade axiom full of meaning to the progressive jeweler. Some

of the jewelers throughout the country seem to thoroughly recognize this, as is shown in the series of windows published in this department.

The appearance of the store, large or small, is the true reflection of business. Even in a comparatively small stocked jewelry store there are commodities that lend themselves well to the window trimmer's art, and an attractive window display is one of the best aids to the selling of jewelry. To verify this statement, one has only to stand near a jeweler's window and watch the close attention a well dressed window attracts. The window display should be changed often.

ONE OF THE READERS OF "THE JEWELERS' CIRCULAR."

Kansas City, Mo., Oct. 10, 1899.

Editor of THE JEWELERS' CIRCULAR:

THE CIRCULAR you have sent to me at Omaha, please forward to above address and oblige. For 10 or 12 years I took THE CIRCULAR at Clinton, Ia.; also 15 years at Omaha; and now we hope to receive it in this city double the years of others. We always read THE CIRCULAR. Yours truly,

C. S. RAYMOND.

# BRADLEY & HUBBARD MFG. CO.

Have produced for this season's trade the finest line of goods ever offered.

## Art Metal Goods,

PITCHERS, VASES, CANDELABRAS, FIGURES, BUSTS, TABLES, ETC.....

## Reception Lamps

WITH THE CELEBRATED "B. & H." and B. & H. RADIANT BURNERS. NEW AND ORIGINAL DESIGNS. HANDSOME AND EXCLUSIVE FINISHES.

*Dealers are cordially invited to inspect the line of Samples at our SALESROOMS.*

NEW YORK: 26 Park Place to 21 Barclay Street.

BOSTON: 160 Congress Street.

CHICAGO: 131 Wabash Avenue.

PHILADELPHIA: 714 Betz Building.

FACTORIES and OFFICES: MERIDEN, CONN.

# PAIRPOINT MFG. CO.

New Bedford, Mass.

## LATEST CONCEPTIONS

...IN....

Rich Cut Glass,

Silver Plate

...AND...

Table Ware.



38 Murray St., New York City.

Temple Building, Montreal.

ALOIS KOHN & CO., 4 MAIDEN LANE, SOLID GOLD CHAINS, Near Broadway, N. Y.

We call the attention of the Trade throughout the country to our line of

## LORNETTE AND GUARD CHAINS.

Will send Samples on Memorandum on receipt of satisfactory reference. Correspondence Solicited.

Established 1879.

Manufacturer of

LOUIS W. HRABA, Fine Leather Goods

29 East 19th St., New York.

Exclusively for the Jewelry Trade.



SAMPLE OF ENGRAVING DONE ON THE Eaton-Engle Engraving Machine.

CATALOGUE AND SAMPLE OF WORK FREE.

EATON & GLOVER have removed to the FULTON BUILDING, 87 NASSAU ST., Cor. Fulton, N. Y.

# WHEN

YOU CONSIDER GAS FURNACES

THINK OF

E. P. REICHELME & CO.,

23 JOHN STREET, N. Y.

## CROUCH & FITZGERALD,

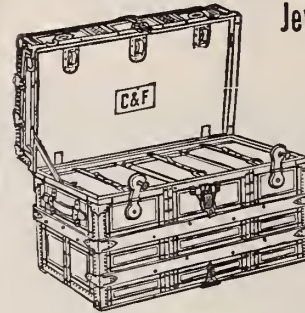

Jewelry Trunks and Cases,

161

Broadway,

Bet. Cortlandt and Liberty Sts.

688 B'way,

723 6th Av.

NEW YORK.

J. R. WOOD & SONS, 21 MAIDEN LANE, NEW YORK.



Manufacturers of



SEAMLESS PLAIN SOLID GOLD RINGS,

Diamond Engraved Stone and Child's Rings,

No Rings Stamped Different from Quality. Send for Catalogue and Price List.

Cash paid for old gold or silver or taken in trade. If allowance is not satisfactory, notify AT ONCE and will return in same condition as received.

## DR. KNOWLES'

...PRIVATE COURSE IN...

# Optometry

will be conducted during the month of November in Portland, Me.

For terms and important particulars write to

R. H. KNOWLES, M. D.,

480 CONGRESS STREET,

(OPP. THE PREBBLE HOUSE), PORTLAND, ME.

H. M. RICH & CO., Jewelry - Auctioneers,

7 and 9 Franklin St.,

BOSTON, MASS.

## WOOD & HUGHES,

Sterling Silverware Manufacturers,

FINE PLATED WARE,

No. 24 John Street, - New York.



## The Rambler's Notes.

WHAT THE RAMBLER SAW AND HEARD AMONG THE DEALERS IN ART POTTERY, CUT GLASS, BRONZES, ETC.

**CATALOGUE OF ART METAL GOODS.** **J**EWELERS who are about to complete their holiday stock of art metal goods, chafing dishes, etc., will, no doubt, be interested in the new catalogue issued by the Goodwin & Kintz Co., Winsted, Conn. This book, which is 9x6 inches, contains 36 pages giving half-tone and wood-cut illustrations of the clocks, candelabra, bronzes, clock ornaments, 5 o'clock teas, chafing dishes, inkstands, vases and other articles manufactured by this concern, as well as prices, discounts, etc. It will, no doubt, prove a handy auxiliary to the buyer of these lines.

**NEW SUBJECTS IN CASTELLINA BUSTS.**

**O**NE of the most noticeable features of the small busts in Castellina marble, this season, is the number of celebrities in the fields of music, poetry, fiction, drama and thought to be found among the subjects used. While it is true that busts of Mendelssohn, Mozart, Goethe, Wagner, Shakespeare, Milton and others have been shown before this, the same subjects this year are much improved in workmanship, and are better likenesses, being taken now directly from correct German and English models. Among the notable additions this season are busts of Dickens, Byron, Schiller and interesting subjects of the present day—Rudyard Kipling and Cecil Rhodes.

**EXCLUSIVE NOVELTIES IN FINE WARES.**

**H**ARRIS & HARRINGTON'S ware-rooms, 32-34 Vesey St., New York, which are now replete with their full Fall stock of clocks, bronzes, miniatures, bric-à-brac, pottery and fancy goods, are becoming noted for their number of exclusive novelties. Most of these novelties have been in clocks of various kinds, and the latest are to be seen in the regulators just opened. Unlike the various styles of rich gilt and enamel pieces of which the market is full, the new regulators that have been added by this firm come in odd and attractive effects following the Empire and Old English styles. Some of these are in gilt, while others are in Sienna marble with trimmings of real bronze in a deep, dull green

finish. Candlesticks and candelabra come in styles similar to the clocks.

**MINIATURES, HAND PAINTED PLAQUES, ETC.**

**L.** STRAUS & Sons have for some time been noted for the beautiful assortment of fine miniatures and hand painted plaques and panels which they carry for jewelers; but never before have they shown a more thoroughly artistic or richer line of these goods than that which now graces the shelves of their warerooms, 42-48 Warren St., New York. The plaques, while of several grades, are all finely executed, with subjects taken from the cele-

brated paintings in the European museums. While many semi-nudes appear among the subjects, all are in perfect taste and without the slightest feature that would shock the most prudish of the jewelers' customers. The plaques come in rich gilt Italian carved wood frames, though they may also be had unmounted. In connection with these is a line of handsome hand painted plates in the finest Vienna styles, with head or figure centers and richly ornamented gilt borders.

## Beautiful Jeweled Rookwood Vase.

**T**HE Rookwood vase represented here is the latest production of Mrs. Belamy Storer, which received much praise



ROOKWOOD VASE ORNAMENTED WITH JEWELS.

at the last Paris Salon. It is about 18 inches high and 24 inches in diameter. The elephants' eyes are of moonstones, and five of the nine heads have turquoises, opals or topazes held in their trunks. The body of the vase is dark brown, with lighter patches of reddish gold, and the leaves have a green "patine" (verdigris) in the veins, which gives a nice play of color. The heads of the elephants are of a shining brown, shading to black on the trunks. This coloring of the bronze involves much knowledge of chemistry and is very interesting. It is done with diluted acids and alkalis which affect the copper, and much of such experimental work is quite new in artistic bronze.

THE RAMBLER.

## A Costly Umbrella.

**T**HERE belongs to the Sultan Abdul Hamid an umbrella or parasol which cost the fantastic price of 150,000 francs. As a collector of rare jewels, the Sultan

John R. Reeves recently succeeded E. A. Maxwell, Albion, Ill.

"By Using Our Goods Your Goods Will Sell."

## We Always Lead

With Something New and Artistic for Manufacturing Jewelers.

OUR FINDINGS SPEAK FOR THEMSELVES

Call or Send for Samples of

## OUR LATEST

And Keep Your Trade Guessing What You Will Show Them Next.

We are now showing a handsome and complete line of

**MEDALLIONS AND EBONY MOUNTS.**

# HEIMBERGER & LIND,

158 PINE ST., METCALF BUILDING, PROVIDENCE, R. I.



ARE KNOWN TO THE JEWELER'S CUSTOMERS AS THEY ARE TO THE JEWELER, HAVING FOR 50 YEARS OCCUPIED THE PROUD POSITION OF "THE BEST."



THE "BRYANT" MARK IS ACKNOWLEDGED TO BE A GUARANTEE OF QUALITY, STYLE AND FINISH.

GOODS SENT ON APPROVAL TO RESPONSIBLE DEALERS.

Our new Fall line comprises a profusion of new designs.

**M. B. Bryant & Co.,**  
10 Maiden Lane, New York.

### Queries by Circular Readers.

**Note.**—Questions under this department will be answered as promptly as possible. Some queries require careful investigation before a satisfactory answer can be given; hence such answers are often seemingly delayed. THE CIRCULAR desires every jeweler to take advantage of this department.

NEW YORK, Oct. 22, 1899.

Editor of THE JEWELERS' CIRCULAR:

I am a steady reader and close admirer of your valuable magazine. I am not a jeweler myself, but know your issue to be well represented among my jeweler friends. I write to ask you to lead me to the best method of procedure with regard to a talent I possess of being able to execute beautiful, original ornamental designs, such as are used in monograms, on watch cases, medals, etc. I can originate many such designs in short order, highly executed. I remain respectfully,

S. QUINT.

**ANSWER.**—We would infer that the ability of correspondent lies in the field of drawing ornamental details; in other words, that he has some skill in ornamental drawing, but is not a practical worker in metals or an all-round designer; that he is not, for instance, an engraver, and has no practical knowledge that may be applied to the making of jewelry, watch cases, etc. It is possible that some of the bigger manufacturers may need some such ability in their designing department, where it would be used subordinately to the designers' work. The only way that we see for correspondent finding a market for his ability is to advertise just what he can do in the best circulated paper, or make a personal application to the officials of the various large firms in the jewelry and kindred lines.

KENDALLVILLE, Ind., Sept. 29, 1899.

Editor of THE JEWELERS' CIRCULAR:

Will you please tell me where in Workshop Notes I can find how to put the Roman color on rings and other pieces of jewelry? If it is not in the book, will you please tell me in Workshop Notes of your next issue?

Respectfully yours,

CHAS. G. BECKMAN,  
With L. Beckman.

**ANSWER.**—In "Work Shop Notes for Jewelers and Watchmakers," pages 138 and 170, correspondent will find paragraphs on Roman Gold Coloring. As stated in "Work Shop Notes," nearly every jeweler has his own method of coloring, which, being the result of many experiments, is held by him as a trade secret. Below, however, is given a French method for coloring gold: A solution is made of two parts nitre, one part Roman alum, and one of sea salt. The jewels or articles of gold are kept in the solution at a boiling point for from 15 to 25 minutes, and then washed in water. The surface of the gold is dull but perfectly uniform and ready for burnishing.

FAIRPORT, N. Y., Oct. 20, 1899.

Editor of THE JEWELERS' CIRCULAR:

We would like to see in your valuable CIRCULAR the operation for up-to-date diamond mounting; how to set diamonds from the way the mounting is received from the factory until it is set, including what tools to be used, and oblige,

A. G. HARDICK.

**ANSWER.**—Diamond setting is a trade, and it is practically impossible to teach it by means of literary articles or by correspondence.

W. J. Joynton opened a repair shop in Amite City, La., recently.

**WM. H. BALL & Co.,**

MANUFACTURING JEWELERS,

Anderson Building, 12-14-16 John St., N. Y.

Curb Bracelets, Bangle Bracelets, Fancy Stone Bracelets, Baby Esther Bracelets, Bracelet Mountings.

**B. I. 4**  
TRADE MARK

Our Specialty:

**Everything in  
Gold Bracelets.**



# Stella Music Boxes

ARE UNEQUALED FOR

Sweetness,  
Harmony and  
Volume

of tone, and have smooth  
metallic tune sheets playing  
thousands of tunes.

**Why Not** handle a line of Music Boxes the sale of which you can control and **Make Money?**

WRITE FOR CATALOGUE AND TERMS.

**Jacot & Son,** 39 UNION SQUARE,  
NEW YORK.

## W. C. A. WESTPHAL, WATCHMAKER,

41 Maiden Lane, NEW YORK.

Established 1892. Telephone, 3684 Cortlandt.  
Estimates, Repairing, Adjusting of Chronometers, all  
Complicated Watches and Fine Time Pieces.

### DEMAGNETIZING.

Watches made Non-Magnetic.  
Fine Wheel and Pinion Cutting

These well-known Razors, the quality of which is warranted, possess this great advantage, that they may be used for ten years before they require actual sharpening. Before using them it is necessary to rub them on good leather strop. Le Coultre's Stropps (to be had with the Razors) should be used in preference to others.

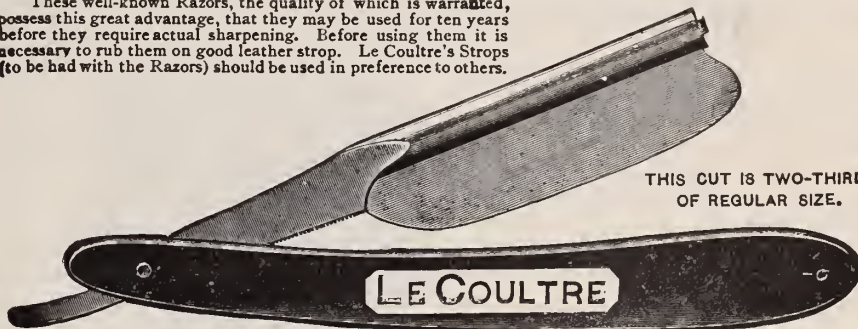

"SPECIAL"—Single Razors for Jewelers' Travelers at trade price.

## MATHEY BROS., MATHEZ & CO.

Send for Price List.

Sole Agents, 21 & 23 MAIDEN LANE, N. Y.

## American Watch Case Co.,

**A.W.C.CO**

9-11-13 Maiden Lane,

Gill Building, New York.

## FERD. FUCHS & BROS., SILVERSMITHS,

MAKERS OF STERLING SILVERWARE,

34 East 29th St., - New York.

**ESSER & BARRY,** Largest Manufacturers of  
IMITATION DIAMOND JEWELRY  
IN AMERICA.  
Write us for samples of almost anything with an Imitation Diamond in it.  
MAIN OFFICE AND FACTORY, 101 SABIN ST., PROVIDENCE, R. I.



GOLD SHELL.

"Buy direct from the manufacturer and get  
all that is coming to you."

SEND FOR OUR "HOT CATALOGUE, CONTAINING  
COLD FACTS AND PRETTY PICTURES."

**CLARK & COOMBS,**

86 WEST EXCHANGE ST.,

PROVIDENCE, R. I.

WE ARE  
HEADQUARTERS  
FOR.....

**Gold  
Shell  
Rings...**

## AIKIN, LAMBERT & CO.,

MANUFACTURERS OF

FINE GOLD PENS, HOLDERS, PENCILS,  
TOOTH PICKS and NOVELTIES.

PAUL E. WIRT FOUNTAIN PENS, at new and lower prices . . .  
MERCANTILE FOUNTAIN PENS, guaranteed to give satisfaction.

Catalogues with terms and discounts furnished to the trade.

BRANCH, 103 STATE STREET, - - - CHICAGO.

## AIKIN-LAMBERT JEWELRY CO.,

IMPORTERS OF

# DIAMONDS.

JOBBER IN

WATCHES, JEWELRY, CHAINS,  
NOVELTIES, ETC.

LATEST DESIGNS.

LOWEST PRICES.

19 MAIDEN LANE, NEW YORK.

# CHAS. F. WOOD & CO., DIAMONDS

1 MAIDEN LANE, NEW YORK.

IMPORTERS AND CUTTERS.

## DIAMONDS.

LARGE ASSORTMENTS.

DESIRABLE SIZES.

ATTRACTIVE PRICES.

**R., L. & M. FRIEDLANDER,**

**30 MAIDEN LANE, N. Y.**

97 HATTON GARDEN, LONDON.

## HALL CLOCKS,



*Mantel Clocks,  
Traveling  
Clocks,  
Clock Sets,  
Regulators,  
Bronzes,  
Vases, Ivory  
Miniatures  
and Art Goods.*

Fall Line Now Ready.

**Harris & Harrington,**

32 and 34 VESEY ST., NEW YORK.

Sole Agents to the Trade for J. J. Elliott & Co., London.

IMPORTERS AND CUTTERS OF **Diamonds** 65 Nassau St. NEW YORK. Cor. John.

**DIAMONDS** and Cutters. **L. & M. KAHN & CO.,** 172 Broadway, **DIAMONDS** Cor. Maiden Lane, N. Y.

**Silver Clocks  
and Photo Frames,**

**Gilt Regulators,  
Cut Glass,  
Fine China  
and Porcelain.**

**LE BOUTILLIER & CO.**

18 East 17th St., New York.

## HOROLOGICAL DEPARTMENT,

BRADLEY POLYTECHNIC INSTITUTE,

PEORIA, ILLINOIS.

Largest and best watch school in America. We teach Watch Work, Jewelry, Engraving, Clock Work, Optics. (Formerly Parsons' Horological Institute.) Catalogue Free.



## 37 YEARS OF HONEST RETURNS

IS OUR GUARANTEE OF SATISFACTION TO ALL OUR CUSTOMERS.

WE DO OUR OWN SMELTING,

**JOHN AUSTIN & SON,**

ASSAYERS, REFINERS AND SMELTERS,  
74 & 76 Clifford St., Providence, R. I.

TELEPHONE, 2434 18TH ST.

**FAIRCHILD & JOHNSON CO.,** 220 FOURTH AVE., NEW YORK CITY.

SUCCESSORS TO LEROY W. FAIRCHILD.

We beg to announce:—

We will continue to manufacture the same high-grade goods and respectfully solicit a continuance of your patronage.

HARRY P. FAIRCHILD, Prest.  
E. S. JOHNSON, Secy. and Treas.

GOLD PENS, PENCILS,  
PENHOLDERS, &c.

## Satisfaction

AND....

## Promptness

is the secret of our success. Our chief aim has always been to render prompt returns and to give satisfaction to all our customers.

**CONLEY & STRAIGHT,**

GOLD AND SILVER  
REFINERS, ASSAYERS and  
SMELTERS,

236 Eddy Street, PROVIDENCE, R. I.

## S. & B. LEDERER CO.,

FACTORY, 100 STEWART ST., PROVIDENCE, R. I.

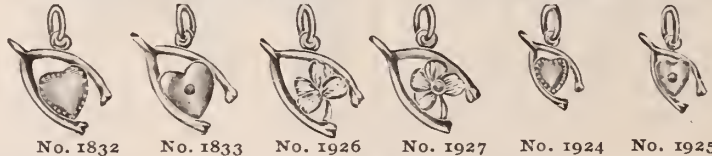

No. 1832 No. 1833 No. 1926 No. 1927 No. 1924 No. 1925

A FULL AND COMPLETE LINE OF

## Solid Gold, Rolled Plate and Sterling Silver Hearts

With or without Stones in a thousand different designs.

THE BIGGEST NOVELTY FOR THE HOLIDAY TRADE.



No. 1940 No. 1941 No. 1936 No. 1937 No. 1938 No. 1939

NEW YORK OFFICE, 11 JOHN ST.

CHICAGO OFFICE, 131 WABASH AVE.

**PROV. STOCK CO.** HIGH GRADE ROLLED PLATE  
**Chains**  
BRACELETS, LORGNETTES.

**10K. GOLD**  
Scarf Pins, Brooches,  
Neck Chains, Lorgnettes,  
Bracelets.

**P.S.C.**  
HIGH GRADE SEAMLESS WIRE  
WARRANTED TO GIVE SATISFACTION  
**PROV. ST. CO.**



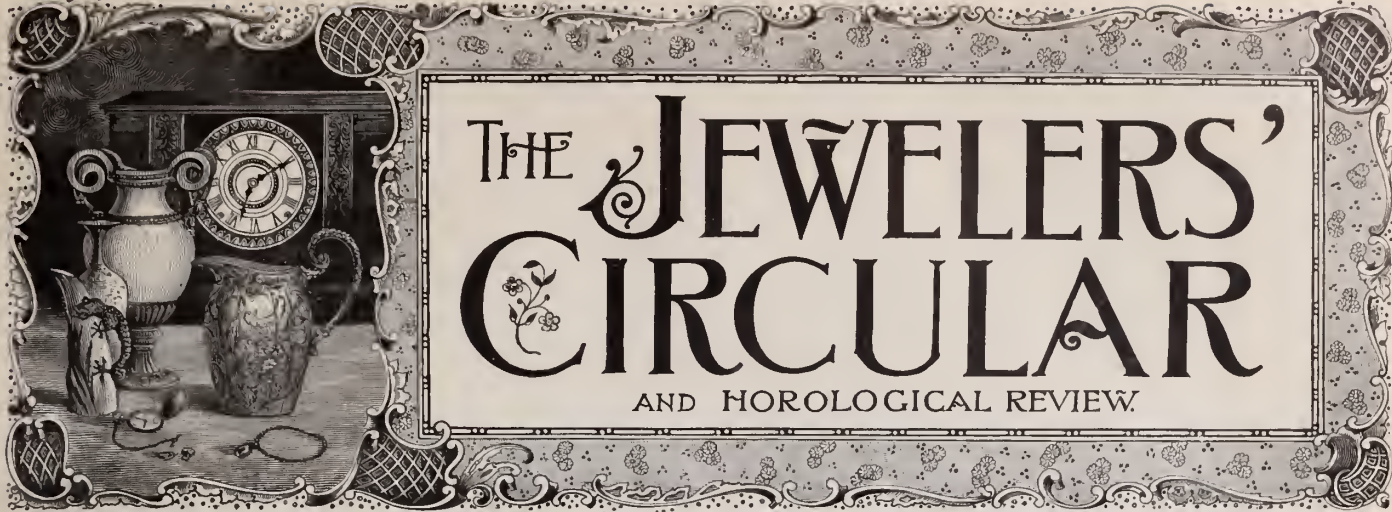

# THE JEWELERS' CIRCULAR

AND HOROLOGICAL REVIEW.

Corbin Building, 11 John St., Corner Broadway, New York.

Copyrighted by THE JEWELERS' CIRCULAR PUB. CO.

Entered at the Post Office in N. Y. as second-class matter.

VOL. XXXIX.

NEW YORK, WEDNESDAY, NOVEMBER 8, 1899.

No. 15.

## THE ARTISTIC EMBELLISHMENT OF WATCHES.

IN the show window of a large watch store in Zurich is exhibited a watch which could pass as a very valuable *chef d'oeuvre* of the horological art, both as regards the mechanism and the decoration. This rare piece is destined to bear testimony at the coming Paris Exposition of the degree of perfection which the watchmaker's art has attained in the now closing century. The watch was made in the *ateliers* of the firm of Marchand & Sandoz, Chaux de Fonds, one of the chief seats of the Swiss horological industry. This splendid timepiece is a striking watch and announces in a clear tone the quarter, half and full hours. It also repeats the minutes and records the days of the month and of the week, as well as the date and the phases of the moon. It runs on 37 rubies, and weighs 550 grammes, 360 grammes of which are gold. The diameter of the watch is eight

centimeters, its height, including the bow, 11 centimeters. One of the illustrations (see page 54) affords a glance at the wheel work of the watch, the other shows the dial. The latter consists of lightly grained dead gold, the figures being laid on in lustrous gold. In the center is a star composed of small diamonds, while the hands are set with small rubies. Above (at XII) is a circle which records the month.

At the left thereof is one showing the day of the week, and at the right that giving the date. With the seconds circle below is combined the recorder of the changes of the moon. But it is upon the spring covers that the gorgeousness of the watch is unfolded. The illustration here shows the timepiece with the case open. It scintillates in its profusion of diamonds, 165 of which were necessary for the embellishment. The lids are enameled in gar-

### Copy of an Ancient Treasure.

THE celebrated Roumanian treasure discovered in 1837 by the peasants of Pietroassa and reproduced by order of the King of Roumania for presentation on the occasion of the marriage of the hereditary Prince of Vienna with Princess Pauline of Wurtemberg, has a varied history. Dis-

dained by the peasants who discovered it accidentally while spading the ground, and who exchanged it to Bohemians for a copper vessel, it was not appreciated until two years later, when a Greek traveler hastened to buy all the scattered pieces he could find. It came to light that it was the treasure of Atanarich, King of the Visigoths. The news of the discovery reached the ears of Prince Ghika, Minister of the Interior and brother of the Prince of Wallachio, who grad-

ually secured the greater part of it for the collection of the Prince at Bucharest. But thieves made off with a portion, and the most beautiful pieces, including a necklace of the Gothic King with an inscription, disappeared. Many of the objects obtained were injured. The principal piece, a grand plate of gold covered with small inlaid figures of precious stones, was intrusted to a Berlin jeweler to be repaired and copied.



20,000 FRANC WATCH TO BE EXHIBITED AT PARIS EXPOSITION OF 1900.

net, and against this ground the glittering stones set *à jour* stand out well. The back cover is simpler in design than the top one, which is magnificently ornamented with tendril-like leaves and flowers. It required no less than two years to complete this masterpiece, hence a goodly amount of wages is stored away in it. The price is fixed at 20,000 francs.



ILLUSTRATION 1/8 SIZE.

**JEFFERSON PATTERN.**

- |                                |   |                                    |                               |
|--------------------------------|---|------------------------------------|-------------------------------|
| 1307 Coffee (6 half pints).    | 908 Large Cloth Brush.                  | 1153 Cigar Jar (Victoria pattern). | 1382 Cut Glass Pungent.       |
| 1306 Large Tea (5 half pints). | 912 Large Bonnet Brush.                 | 983 Small Puff Box.                | 922 Shoe Hook.                |
| 1302 Small Tea (1 1/4 pints).  | 904 Large Mirror.                       | 976 Paste Box.                     | 927 Shoe Horn.                |
| 1304 Large Sugar.              | 1015 Whisk.                             | 1201 Cut Glass Bon Bon.            | 918 Nail File.                |
| 1301 Small Sugar.              | 996 Comb.                               | 1292 Cut Glass Candle Stick.       | 1281 Cut Glass Violet Holder. |
| 1303 Large Creamer (1 pint).   | 916 Nail Polisher.                      | 1157 Heart and Crown Coin Box.     | 1284 Cut Glass Crown Salts.   |
| 1300 Small Creamer (1/2 pint). | 888 Manicure Scissors.                  | 1378 Ink (American Beauty).        | 1385 Cut Glass Cologne.       |
| 1305 Spoon Holder.             | 893 Bankers' Shears.                    | 1285 Cut Glass Pungent.            | 1023 Pin Tray.                |
| 906 Large Hair Brush.          | 1145 Large Puff Box (Victoria pattern). | 1381 Cut Glass Pungent.            |                               |

Send for our small catalogue showing our latest productions in sterling silver goods, and do not fail to call for some of those beautiful little Brooches we have just brought out.

**THEODORE W. FOSTER & BRO. CO.,**

100 RICHMOND STREET, - - - PROVIDENCE, R. I.

**A USEFUL NOVELTY**

**Bottle Openers,**

in Sterling Silver and Silver Plate. The convenience and cleanliness of this form of bottling having brought it into general use, these Openers will be appreciated for the table. Send for catalogue.

MADE BY

**Goodnow & Jenks,**  
SILVERSMITHS,

Stanhope and Morgan Sts.,  
Boston,

who have obtained the SOLE RIGHT from patentees to manufacture this article.



# The Best.

## The "DOUBLE-BASE" Engraving Block

shown upon this page is regarded by the users of the same as the best block for the price, viz. :

### \$15.00,

on the American market. The attachments, consisting of Spoon Holder, Button and Bangle Attachments, Ring Holder, Cement Plates, 8 sets (4 each) Pins and Pegs, and Leather Pad, are more than are given with any other block. It is a better finished block and more work can be done with the same than with any other block offered for sale.

### An Absolute Guarantee Is Given With Every Block.

In addition to the above attachments, we can furnish you with a Thimble Holder (2 pieces) for 50 cents; Cane and Watch-Cap Holder (4 pieces) for 75 cents; Cement Plates from 25 cents to 50 cents, and Polished Hardwood Base, with drawer and glass shade, for \$3.50.

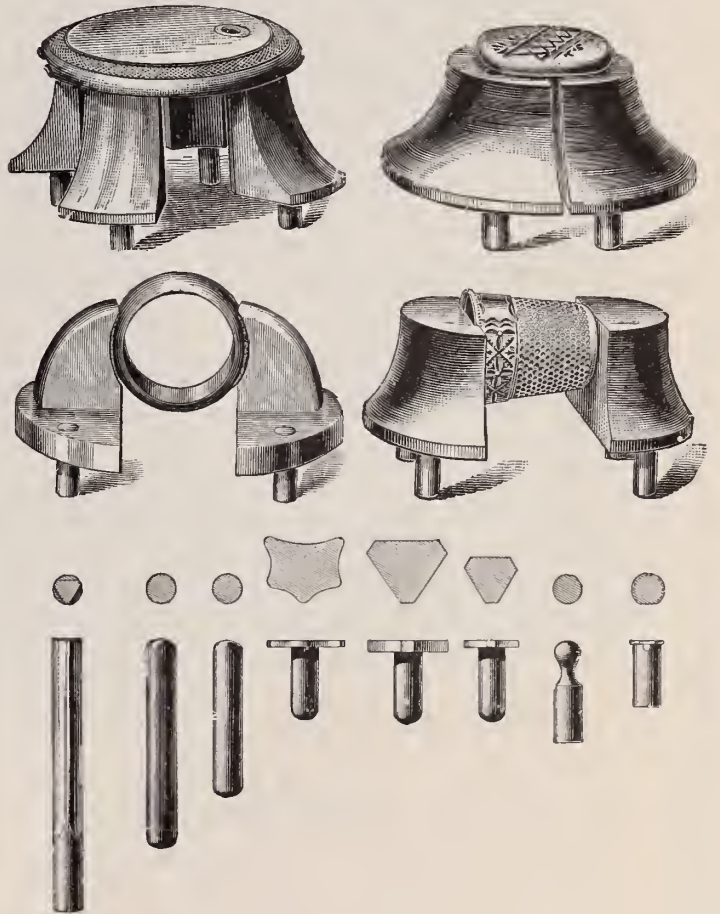
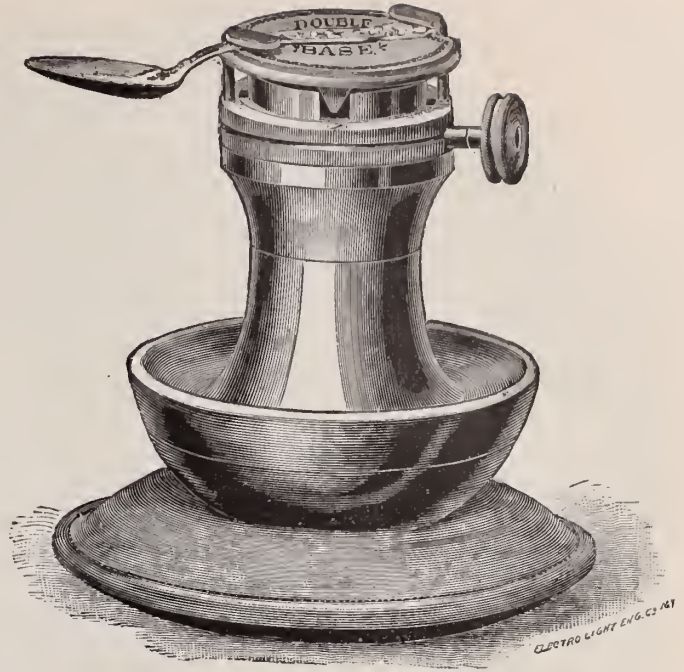

## L. C. REISNER & CO.,

Manufacturing Jobbers, Importers and Exporters,  
Watch Materials, Tools and Supplies,

Jewelry Repairers for the Trade.

LANCASTER, PA.



Bonbon Dish,  
No. 2142.

*"Sterling Silver Goods Only."*

This is only one of our new  
**BONBON DISHES**



TRADE-MARK.

**FRANK M. WHITING  
& CO.,**

**Silversmiths,**

**NORTH ATTLEBORO, MASS.**

1128 Broadway, New York.  
220 Sutter St., San Francisco.

Complete line of Samples always on display  
at our New York Office.

Our line of Dishes, Trays, Bowls,  
Tea Sets, Loving Cups, Toilet  
Goods, etc., is very complete  
this season.

## Of Greatest Importance

to the live manufacturing Jeweler is a careful  
consideration of our lines of Jewelers' Findings.

NEW ASSORTMENTS OF

**Buckles, Galleries, Brooches,  
Settings, Pins, Etc.**

**THOS. W. LIND,**

MANUFACTURER OF **JEWELERS' FINDINGS,**

67 FRIENDSHIP STREET,

PROVIDENCE, R. I.

# Library and Desk Goods.

Our assortments of Sterling Silver Library and Desk Goods require no "booming."



The cut illustrates some of the patterns. The jeweler who desires to enliven his novelty stock, here has his opportunity.

*Prices on application.*

## The Mauser Mfg. Co.,



"Watch Our Ads."

...SILVERSMITHS...

15th Street, between Broadway and 5th Avenue, NEW YORK.

1835 R. Wallace  
TRADE MARK

Do you know why you are receiving inquiries for

**“ 1835 R. Wallace ”** ?

Silver-plated Spoons and Forks

If not, write us, and we will tell you what we are doing to familiarize the public with this trade mark and create a demand for this line.

“ 1835 R. Wallace ” Silver-plated Spoons, Forks, etc., have no superior in design, plate or finish. If you have not received our latest catalogue illustrating and describing this ware, also giving a short history of the growth of the Silver-plated flat ware industry in this country—drop us a card and we will send you a copy.

This line is manufactured only by

**R. Wallace & Sons Mfg. Co.,**  
WALLINGFORD, CONN.

Branches: { 120 Sutter St., San Francisco.  
109 Wabash Ave., Chicago.  
226 5th Ave., New York City.

1835

1899

**Latest Fashions in Paris.**

PARIS, Oct. 13, 1899.

**THE EGG TALISMAN.**

**T**HE latest trinket worn by the fashionable Parisienne is an egg of gold and colored enamel. The superstitious carry these dainty "luck-giving" amulets on a fine, gold chain around the neck, generally hidden under the dress. The enameled design executed on the plain gold ground of the egg is chosen, with preference, in green, red and blue. These fashionable, "good luck" eggs may, of course, also be richly incrustated with pearls, diamonds, emeralds and other precious stones. The obliging jeweler is entirely guided by the taste and the purse of the lady customer. A very pretty talisman of this description is an egg dressed in dull blue enamel, from whose broad, open extremity the exceedingly wee head of a young chicken in mother-of-pearl peeps out. Many of these egg shaped *bijoux* are hollow and can be opened like a locket, to receive a small lock of hair from the head of the lover. This egg talisman owes its popularity to a pretty *danseuse* at the Folies Bergères, who, one night, wore as an only ornament an egg set with emeralds on a golden chain wound three times around the neck. In consequence of a prevailing fashion in ladies' dresses, coral has been restored to favor. Coral strings were, in former times, considered a necessary adjunct to the muslin dresses now

**THE RESURRECTION OF CORALS.**

ladies' dresses, coral has been restored to favor. Coral strings were, in former times, considered a necessary adjunct to the muslin dresses now

fashionable once more. Probably its red color, on whose beauty there is no disparity of opinion, has a good deal to do with it. Whatever may be the reason, it seems certain that the coral will again try to acquire a prominent place in the jeweler's art. At first we saw it in the shape of strings and chains, so popular of old and again at the present time. In long chains one notices a round coral and crystal glass or corals and gold pearls alternating, or else the gold chains show corals at regular intervals. The strings of coral pieces of irregular cut have also reappeared. One of the prettiest and most ingenious chain combinations is that of corals and pearls. Originally the red coral, which doubtless enhances the beauty of dark types, was more in demand, but now the delicate pink color is preferred. There is shown, for instance, a gold lorgnette chain, which has at regular distances a large delicate pink coral and the lorgnette frame of repoussé gold is embellished with coral crescents, in the center of which a small diamond is seen sparkling. For brooches and pins the corals are naturally employed cut as pearls and *boutons* and as drops or *en cabochon*, likewise for ear rings, leaves, flowers and other shapes. Thus, the center of a charming little round brooch is formed by a rose bud beautifully cut in coral, which, in turn, rests in a wreath of wee leaves, nicely fashioned in dead gold. A similar theme is a lily chalice with a golden stem around it. There are also pins in this *motif* as well as in the shape of small, gold framed coral hearts. A pretty combination is that of coral and pearl in various handsome

brooches representing crescent and star. The crescent and the center of the star are corals, while the rays are composed of pearls. This design is very suitable for a variation of the two stones in their composition. Coral cameos are seen in some cuff buttons set in silver. In isolated instances, shirt studs, belt buckles, etc., with corals are also met with, but this is probably merely a personal taste. It may be expected that this pretty though only semi-precious formation of nature will again remain in vogue for some time.

Belt buckles and cloak clasps are shown by the pair, in elegant cases. The latter are now produced in a considerable size and principally represent plants, enameled or in gold and silver shades.

**Virgin Mary's Wedding Ring.**

[London Globe.]

**I**T was recently stated in a society paper that a ring, said by Roman priests to be the Virgin Mary's wedding ring, was among the treasures of a church at Perugia. The *Church Gazette*, having insinuated doubts as to the genuineness of the ring, a correspondent, writing to that paper, says: "It may be as well to state that the ring in question was of onyx or amethyst. It was given in 996 by a jeweler of Jerusalem to Ranerius, a diamond merchant from Clusium. Its wonderful properties were discovered on the miraculous restoration to life of Ranerius's son. It was stolen from Clusium and transferred in 1846 to Perugia."

**Holiday Goods.**

*To the Trade:*

We present our stock of goods to the attention of the Jewelry Trade with the assurance that it is not surpassed in extent, character or price.

**MAKE SELECTIONS NOW FOR THE HOLIDAYS.**

- STERLING SILVER:** Toilet Ware, Desk Goods, Novelties, Flat Ware, Hollow Ware.
- UMBRELLAS, WALKING STICKS, CROPS AND WHIPS:** Exclusive designs in Silver and Gold, some richly jeweled. Delicate Ivory Carvings, Stag Horn, Ivory and Natural Woods, mounted with unique and original designs.
- LEATHER GOODS:** Traveling Bags, with and without Toilet Fittings; Pocketbooks, Card Cases and Chatelaine Bags, mounted in Silver and Gold; Portfolios and Desk Pads, mounted in Silver. We control and make a full line of goods in Walrus and Buffalo Leather.

**ORDERS WILL RECEIVE PROMPT ATTENTION.**



**Gorham Mfg. Co., SILVERSMITHS,**  
**Broadway and 19th Street, New York City.**

BRANCHES—New York, 21-23 Maiden Lane. Chicago, 131-137 Wabash Ave. San Francisco, 118-120 Sutter St.  
 WORKS—Providence, R. I., and New York.

### FASHIONS IN MANY FIELDS.

SUGGESTIVE IDEAS FOR JEWELERS FROM THE BEST FOREIGN FASHION AUTHORITIES.

The latest fad that has overtaken the Parisiennes with regard to their *dessous* is to have jeweled hooks and eyes to their corsets. Petticoats are also kept in place by a large bejeweled hook. Garters, instead of slipping on with elastic, are clasped with a gold or enamel hook and eye, beset with jewels and much ornamented with bows of ribbon and lace.

The sleeve of the moment for evening wear—which, by the way, is no sleeve at all, consisting of a chain or two, or a mere nothing of a band of flowers—necessitates long gloves, and these are held up by the aid of a jeweled chain passed through the shoulder strap and clasped with a gold tassel. Three narrow straps of velvet, each bearing a gold or jeweled buckle, furnish another airy simulacrum of the sleeve.

Girdles composed of alternate links of filigree gold and enamel, or cabochon emeralds and rubies, knotted and allowed to hang to the feet, are being prepared by the denizens of the Rue de la Paix for their votaries, to whom the incoming vogue of the Princesse gown makes an ornamental ceinture indispensable.

Orange color diamonds appear to be coming into fashion in sets or chains. New, also, and most curious are the long, fine gold chains held together in the center of the neck with a small crab in wrought gold. In the center of its back is a small watch, set in diamonds.

The beautiful new bags seen in the Rue de la Paix prove that the *couturières* do not intend to have any pockets in dresses. The shape is something between a purse and a bag, but it is wider than the usual purse-bag, and not so long; in fact, it is more like two small books placed back to back, for the corners are square and the side pieces go inside. The colors are beige, black, dead-leaf, slate-grey, mouse-grey, all beautifully embroidered with the finest steel, with long, fine steel chains to hang on the arm. The material is kid, doeskin and chamois leather.

A new bag-reticule, the same shape as that carried by our grandmothers, is of the softest black chamois leather, encased in the finest steel, showing the leather through. In the place of ribbon strings, it has a long steel chain to pass on the arm.

There are a great many novelties in pretty steel ornaments, some of them being so fine as to give the suggestion of lace in the distance. Beside the new purse-bags embroidered with steel, there are also beautiful waist buckles in the same style, the belt being of gros-grain ribbon. But the greatest novelty of all is the fine steel chains with two steel pendants attached. They are very *chic* on the stylish new blouses and silk skirts. The chains pass round the sailor's knot of the silk muslin tie and the ends fall low down in the front.

Old fashioned jewelry can once more see the light. Heavy Italian workmanship, broad bracelets, and massive gems may form part of the panoply in fashion's merry war in London.

A charming finish to the costume is the long chain formed of broken enamel sticks with a pearl between each stick. The colors are royal-blue, yellow, and white, with blue in the lead.

Quills in swell English walking hats of felt are kept in place by bird's claws set in silver.

#### September's Exportation of Silver Plated Ware.

WASHINGTON, D. C., Nov. 3.—The returns for the month of September show that the total exportation of plated ware from the United States amounted to \$46,370, the various points of distribution through which it passed out of this country being as follows: Baltimore, Md., \$1,000; Bangor, Me., \$13; Boston, Mass., \$148; New York city, \$29,507; Passamaquoddy, Me., \$118; San Francisco, Cal., \$1,537; Buffalo, N. Y., \$156; Cape Vincent, \$235; Champlain, N. Y., \$1,193; Detroit, Mich., \$700; Memphremagogue, Me., \$494; Niagara, N. Y., \$8,017; North and South Dakota, \$484; Oswegatchie, N. Y., \$620; Vermont, \$2,128.

#### A. & J. Plaut Get \$8,500 for Release of Their Leasehold.

CINCINNATI, O., Nov. 1.—A satisfactory adjustment between the Gibson estate and A. & J. Plaut has been reached, whereby the Plauts will vacate their present leasehold, at 34 E. 4th St., to allow it to be removed for the construction of the Schmidlapp sky-scraper. The settlement is upon a pecuniary consideration of \$8,000, with two months' rent, which amounts to about \$8,500 all told. The firm will vacate by Nov. 24.

A. & J. Plaut had a lease, which expired March 1, 1900, and when the contracts for the other property were closed, refused to give in. The jewelry firm have secured quarters at 14 E. 4th St.

#### A Case Where Creditors Come Out at the Horn's Small End.

BOSTON, Mass., Oct. 30.—In the issue of THE CIRCULAR on Oct. 25 was reported the assignment of Samuel Hubar, Providence, R. I., to Isidore Warshauer and the sale of the stock by the assignee. Warshauer poses as a wholesale jeweler and has a small room in the Jewelers building, this city. About Oct. 20 he called upon a Boston firm who were creditors of Hubar and endeavored to have them sign off their account at 25 per cent, but as the account was small, being less than \$50, the creditors requested Warshauer to get the larger creditors in the city, of whom there were two, to head the list. This he agreed to do, but on Oct. 21 he advertised in a Providence paper that the stock was to be sold at auction, and on the following Monday, before the representative of the Boston firm and one of the larger creditors could get to Providence, although they had taken an early train, Warshauer had sold the whole stock, including the fixtures, in lump for about \$150, the inventory of which was about \$700.

When Warshauer was questioned why he did not let them know that he was going to sell on so short a notice, as they had told him they would go to Providence and look the matter over, he replied that he had not been asked.

# THE APOLLO

WARRANTS THE EPITHET "POPULAR,"

as shown by sales from Maine to Oregon.



Made by J. B. & S. M. KNOWLES CO.,  
PROVIDENCE, R. I.

Established 1852.

STERLING SILVER ONLY.





# LEATHER GOODS!

<b>Walrus Hide,</b>	12 Colors,	Gun Metal Jeweled Mounts.
<b>Sea-Lion,</b>	8 Colors,	14 k. Gold Jeweled Mounts.
<b>Monkey Skin,</b>	24 Colors,	Grey Finish Mounts.
<b>Elephant Hide,</b>	5 Colors,	Green Gold Mounts.

## TRAVELING BAGS,

Plain and with Fittings of

**IVORY, EBONY, SHELL.**

## TOURIST ROLLS,

with Ivory and Ebony Sterling Mounted Fittings.

## CHATELAINE BAGS,

Antique Dutch, Sterling Silver, Gun Metal.  
Mounted in Velvet, Lizard, Sea-Lion, Monkey, Seal.

**Military Purses,** English Pigskin, Brass Letters, Monograms.

**Ebony Toilet Goods.** One Quality—The Best.

**Ivory Toilet Goods.** Unlimited Variety.



# DEITSCH BROS.,

14 East 17th St.,

New York.

### The Validity of the Waterman Fountain Pen Patent Tested.

The question of the validity of the patent granted May 24, 1898, to L. E. Waterman for improvement in fountain pens, was argued at great length Thursday before Judge Wheeler, in the Equity Part of the United States Circuit Court.

This patent is the one which forms the basis of the many suits for infringement brought by the L. E. Waterman Co. against manufacturers and dealers throughout the United States, recorded in THE CIRCULAR from time to time. Three of these dealers against whom suits were brought were Vassar College, Jno. P. Ambler and Robt. B. Sears, and in these three actions demurrers were interposed attacking the validity of the patent. The arguments on all the demurrers which came up last week involved exactly the same issues, so the three were heard as one case. Wm. B. Whitney, who appeared for the defendants, based his whole argument on the claim that the patent was manifestly invalid upon its face and that, therefore, the complaint should be dismissed. The patent, he claimed, was a remarkable one, and though it contained 26 claims, the entire device was nothing but a conical shape in the joints of a fountain pen, or a conical cap joint, combined with a conical nozzle joint. Mr. Whitney then started in to show that the principle of these joints was, as he termed it, as old as the hills, and had been in use since the days of the first bung and bung-hole. He instanced a hundred or so articles in common use, from corks in bottles and hoe handles, etc., to the joints in musical instruments and stove pipes, to illustrate his claim that it was an old principle. In fountain pens, he claimed, it had been used for years, and showed the Court a large number of old patents on fountain pens, which he contended embodied the principles of this invention, but which were never claimed to be patentable before the

time of Mr. Waterman's application. Mr. Waterman's improvement, he said, was only in the appearance of the pen and did not imply any new mechanical principle.

Walter S. Logan, who argued for the complainant, Waterman, started out by saying that there were two prominent questions to be solved in the manufacture of fountain pens. The first was to get the ink out of the pen when you wanted it, and the second was to keep the ink from getting out on your fingers and clothes when you didn't want it. There were many patents for the first, and the courts recognized the difficulty of solving both of these problems to such an extent that no fountain pen patent had ever been thrown out for want of novelty. The question of feeding ink to the paper was no more important than the question of not feeding it to the fingers, and Waterman's improvement was the first pen to overcome the latter difficulty. In the former joints in common use, instanced by Mr. Whitney, as well as in the joints of former fountain pens, friction and not elasticity produced the hold. Waterman's joints held through elasticity and not by friction.

In answering this argument Mr. Whitney contended that it was elasticity to a more or less extent which caused the hold in every joint which he had instanced. Judge Wheeler took the briefs of counsel and reserved decision.

A tramp was killed while riding in a Bluff Line freight car at Lock Haven, Ill., a few mornings ago, by some steel bolsters falling on his head. A card was found on his person bearing the name of R. E. Mitchell, jeweler, Kaufman, Tex., and on the back of the card was the name Carl Heilbrun. A fellow tramp said the dead man had told him that his home was in Fort Worth, Tex., where his father was a banker.

### Frank W. Smith's Suit Against Meriden Britannia Co.

The action brought by Frank W. Smith, silversmith, Gardner, Mass., against the Meriden Britannia Co., came before the United States Circuit Court of Appeals, in New York, Wednesday, on an appeal by Mr. Smith from an order denying to him a preliminary injunction.

The readers of THE CIRCULAR will remember that this action was commenced in Connecticut in the early part of the year, and was based on the alleged infringement of the design patent granted to Mr. Smith for silver hollow ware, Nov. 1, 1898. Mr. Smith claimed that the Meriden Britannia Co. had infringed his patent by making in silver plate, tea sets in nearly the same pattern. He made a motion for a preliminary injunction to restrain the defendants from making or selling this design during the pendency of the action, but this motion was denied by Judge Townsend, in the United States Circuit Court at Hartford, Feb. 21. The opinion of Judge Townsend, at the time, was printed in full in THE CIRCULAR of March 1. It was on the appeal from this decision by Judge Townsend that the case came before Judges Wallace, Lacombe and Shipman, in the United States Circuit Court of Appeals, Wednesday.

The grounds on which the injunction was opposed were, that there was no invention in the patent; that the patent was invalid, and even if it was valid, under its limited scope there was no infringement of it in the design of the Meriden Britannia Co. Decision was reserved.

### Death of Francis Parker Freeman.

Francis Parker Freeman, a well known retired broker, of New York, who died at his home in Lakewood, N. J., on Thursday, was at one time a conspicuous figure in the jewelry district of New York. Mr.

H  L

We Manufacture  
Knives, Forks, Spoons and Cutlery.  
Hollow Ware, Toilet Ware and Manicure Pieces.

The Kind that is sought in Jewelry Stores  
Not found elsewhere.

HOWARD STERLING CO.  
Silversmiths.  
Providence · New York · San Francisco.

# A. WITTMANAUER,

MANUFACTURER OF

## THE CELEBRATED

# Longines and Agassiz Watches,

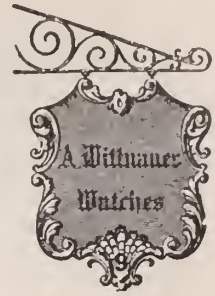

9-11-13  
MAIDEN LANE,  
NEW YORK.



AGASSIZ MOVEMENT  
1899 MODEL.

WHICH HAVE BEEN  
SOLD TO THE LEAD-  
ING JEWELERS OF  
THE WORLD DUR-  
ING THE PAST

## 53 YEARS.



CASE  
1899 MODEL.

WE HAVE A COMPLETE VARIETY OF

## Decorated Watches for the Holiday Trade.

9-11-13 Maiden Lane,     New York.

Geneva Office, 16 Rue du Mont Blanc.

Freeman, who was 72 years of age, was born in Boston, Mass., and went to New York in early life. When a young man he started in the art goods and fancy goods importing business, and 50 years ago was a member of the firm of Coles & Freeman, who were then situated at 5 Maiden Lane. Later the firm became Freeman & Ryer, who had offices at 13 Maiden Lane and subsequently at 391 Broadway.

He left this business in 1873, when at the request of Commodore Vanderbilt he opened a brokerage office in Exchange Place, where the firm of Francis P. Freeman & Co. handled a great share of the Commodore's business during his life, and later represented William H. Vanderbilt's interests to an important extent. Mr. Freeman was a director of the New York & Harlem Railroad and one of the organizers of the Lincoln National bank and the Lincoln Safe Deposit Co. He was a member of the Down Town Association, the New England Society and a trustee of the Metropolitan Museum of Art and of the American Museum of Natural History.

He retired from business in 1896, leaving his only son, Frank M. Freeman, head of the New York firm.

Captain J. E. Towers, who was formerly in Topeka, Kan., and engaged in the barber business, went to Manila with the Kansas regiment, and when he returned to San Francisco, Cal., he developed into a full fledged optician, and is now reported to be doing a very successful business.

#### A Bold Grab Game Worked Successfully in Bohm-Bristol Co.'s Store.

DENVER, Col., Oct. 29.—A cool and daring robbery occurred at 11.15 o'clock this morning in the heart of the business section of Denver. A thief entered the Bohm-Bristol Diamond Co.'s store, grabbed two of the most expensive gold watches in the establishment and within a few seconds was desperately pedaling a bicycle down 16th St., followed by an excited crowd and a man armed with a revolver.

For coolness, the heavy plate glass doors of the store were open, and only the swinging screen doors obstructed ingress from the street, which was crowded. S. B. Bowman, secretary of the company, was behind the counter at the rear, facing the doors and to one side of the diamond rooms with their heavy oak wainscoting and glass walls. The interior effect of the shop is confusing because of the glass and the arrangement of the cases. It was the hesitation on the part of a supposed customer as he entered the store that caused Mr. Bowman to look up. Two colored customers, men, remarked the stranger casually as he passed by. Mr. Bowman also noted his appearance. From their description he wore a faded brown derby hat, a light brown box overcoat and was modestly if not well dressed. His hair was sandy, complexion sallow, and the striking feature of his face was a rather large sandy mustache streaked with gray.

Mr. Bowman, at the man's request, placed two watches, one valued at \$150 and the other at \$125, on the top of the coun-

ter. Screwing his eyes as if to examine them, the man picked up the smaller time-piece first and then the other. He laid one down and looked into the case. Following the direction of his eye, Mr. Bowman went to hand out another. Before he could withdraw his hand the man with the watches took a quick step backward and strode rapidly to the door. For a moment Mr. Bowman looked blank. Then, realizing that the two watches were gone, sprang to where a revolver lay ready for any emergency and ran to the door. The thief had mounted a wheel and was riding a crooked course down 16th St. The pavement was packed with pedestrians. As Mr. Bowman burst through the door, he found himself in a crowd of ladies. Hurriedly breaking through, bareheaded and grasping his revolver, which he had mechanically cocked, he began running swiftly after the man on the bicycle. A mail wagon lumbering down Arapahoe St. interrupted his progress. The slight delay gave the thief a spurt of several yards and he finally escaped.

#### Peoria Merchants Unite to Protect Home Industries.

PEORIA, Ill., Nov. 1.—The Home Manufacturers' Association, of Peoria, now in the process of organization, held their first meeting last week in the assembly room of the City Hall. There were about 30 of Peoria's best known producers present and the meeting was an enthusiastic one. The first step taken toward organization was the election of a board of directors, which consists of representatives from each line of trade represented in the association, five of these members to constitute a quorum with power to transact business. The directory also has the authority to add to its membership as fast as new lines of trade become identified with the association. S. W. Eckley, jeweler, is one of the directors, of whom there are 20.

These directors adjourned to meet on Thursday night of this week, when they will elect officers for the association, and attend to the details of organization. The Home Manufacturers' Association are organized for the protection of home industries, and all their efforts will be in that direction.

#### The Passing of the Rodgers & Pottinger Jewelry & Optical Co.

LOUISVILLE, Ky., Nov. 1.—The Rodgers & Pottinger Jewelry & Optical Co., one of the oldest and most reputable firms in the city, will be dissolved at once, and the stock of the company is being sold out at auction. The purpose in closing out the stock, as stated by the members of the firm, is to effect a settlement with creditors and a dissolution of partnership. Messrs. Rodgers and Pottinger have been business partners for many years. They were located at the corner of 4th and Market Sts. until a short while ago, when they moved into the store at 338 Fourth Ave.

W. A. Sharick, of Shelby, O., has received word from his brother, O. L. Sharick, stating that he has moved from Juneau to Douglass, Alas., where he has opened a jewelry store.

**WATCHES**

**WHO SAID WATCHES?**

Ladies' Watches,  
Gentlemen's Watches,  
**Railroad Watches.**

We Are the Largest Distributors of

**Dueber-Hampden Watches**

IN NEW YORK.



*John W. Sherwood & Co.*

Watches. Chains. Diamonds. Jewelry.

**No. 3 MAIDEN LANE, NEW YORK.**

# THE DUEBER HERALD

THE ADVOCATE OF HONEST BUSINESS METHODS.  
\* DEVOTED TO THE RETAIL JEWELRY TRADE.\*

VOL. I

CANTON, OHIO, NOVEMBER, 1899.

No. 7.

## "EXPLANATORY."

A merchant once overdrew his bank account.

\* \* \*

On the following day he called upon the cashier of the bank and gave him a plausible explanation of how it happened.

\* \* \*

"Your explanation sounds reasonable," said the cashier, "but, Mr. Man, what we want are the accounts that never require explanation. There's a debit and a credit side. Accounts ought to explain themselves."

\* \* \*

Watches, like bank accounts, ought never to require "explanations." A watch is made to show the time of day. If it discharges this duty faithfully and accurately, what need of "explanation?"

\* \* \*

The Dueber-Hampden watch, like the properly conducted bank account, explains itself. The movement is made TO KEEP TIME; the case, to protect the movement, to be an ornament and to contain the exact amount of precious metal paid for.

\* \* \*

The Dueber-Hampden watch has no peer. It is the proudest achievement of America's watch industry.

## THE WATCH AND PUBLIC SAFETY.

One inaccurate watch can cause more railway accidents than all the block systems in the world can prevent.

We have before us the records of two fatal railway accidents, both of which were caused by inaccurate watches,—watches fitted with devices that were unsafe, though undoubtedly accompanied by lucid and interesting "explanations."

Notwithstanding these facts, many railroad managers permit themselves to be "explained" into entrusting the watch inspection on their roads to incompetent, and, moreover, interested persons, who do not shrink from "explaining" new watches upon the employes for no other reason than to force the sale of a "new" movement, supplied with "new" inventions, duly "explained."

Such procedure is manifestly wrong.

Let the retail jeweler enlighten the public and the public will have an opportunity of enlightening the managers of railroads.

Elmira, N. Y.

Have carried my 17-jewel Dueber-Hampden watch for three years. Would not change it for any on the road. It has not varied over a half minute in months, in fact, it is always right.

EUGENE H. RIBBLE, Engineer,  
N. Central R. R.

## A QUESTION AND SOME FACTS.

There are men who would "kick" if you sold them a gold dollar for 95 cents.

\* \* \*

Of these, the least said, the better. We would like to ask you a question about the other kind; the kind who come into your store, buy a good article, and, if wholly satisfied with it, have the manhood to tell you so.

\* \* \*

Have you ever met one of that kind who, after buying a Dueber watch case, came to you and said: "This case is not as represented. I'm dissatisfied?"

\* \* \*

The one glaring peculiarity of Dueber watch cases is that they are exactly as represented. If you sell one, you are sure of a satisfied customer.

\* \* \*

We heard of a retail jeweler once who said that to sell a gold-filled watch case was like "skating on thin ice." Poor, misguided man! He didn't sell Dueber's.

\* \* \*

The Dueber mark on cases is like the Hall-mark of England on silver.

# The Leading Low=Priced

American timekeeper is our new No. 7, 18 size, seven-jeweled movement. Carefully inspected and run before shipment.



Trenton, 18 Size, No. 7, 7 Jewels, Stem-Winding, Lever-Setting Open Face and Hunting.

The No. 7 contains a brass and steel composition balance of a better quality than any other movement of like price.

No. 8 in gilt finish.

SEND FOR PRICE-LIST.

The Trenton Watch Co.,  
Trenton, N. J.

### W. A. England Fined and Jailed for Receiving Stolen Property.

WORCESTER, Mass., Nov. 2.—William A. England, a prominent jeweler in Worcester, was Monday sentenced to pay a fine of \$50 and to serve a term of 30 days in the house of correction, on the charge of receiving stolen property. Motion was made for a new trial by his counsel, Col. Wm. A. Gile, but Judge Sherman overruled the motion and pronounced sentence. Mr. England was immediately taken to the Summer St. jail to commence his sentence. He was assigned to a cell in the east wing of the jail and will work in the chair department caning seats. Fred C. Ball on July 27 stole from Mrs. Fannie E. Maynard a diamond ring, the stone weighing 1 1/3 karats. It contained a flaw, and Mr. England bought the ring from Ball for \$15. He claimed the stone contained a bad flaw and was worth but \$25. Ball admitted to the police he stole the ring, and his case was placed on file. Mr. England claimed he sold the ring for \$35, but could not find the person to whom he sold it. He sent Mrs. Maynard a check for \$75, the value of the ring. For his connection in the ring case he was fined \$20 for violating the city ordinances, and the Board of Aldermen revoked his license to buy and sell old gold and silver. Since his sentence the business has been in charge of John W. Davis, head clerk. The case has attracted considerable attention among business men. His sentence expires Nov. 30.

Mr. England's jewelry store was attached to-day for \$500 by deputy sheriff James Early, at the instance of Sheehan & Cutting, counsel for Charles E. Wheelock, who alleges that England owes him for

board of horse. H. E. Bullard was placed in as keeper, and a keeper was also placed in England's stable. Later in the day the matter was settled through counsel.

### Fire Losses of the E. T. Burgess Cut Glass Co. Adjusted.

MIDDLETOWN, Conn., Nov. 4.—The losses by fire to the E. T. Burgess Cut Glass Co. have been adjusted, and work in the different departments has been resumed. Investigation showed that the damage was not as heavy as at first estimated. The machinery was not injured to such an extent but that the greater part can be placed in service again. The greatest loss was in the finished and unfinished stock and to the patterns, many of which were destroyed. The company will receive \$4,800 in insurance for the damage to the plant. The damage to the building was but slight.

### Proceedings of the Jewelers' League.

The regular monthly meeting of the Jewelers' League was held on Friday, Nov. 3. There were present Vice-President Greason, Messrs. Karsch, Street, Lissauer and L. Stevens, Jr., secretary. Upon motion Mr. Greason was elected chairman pro tem.

The report of the treasurer was presented and approved. Three requests for change of beneficiary were received and granted, and the following applicants were admitted to membership: Wm. Eberhard, Charleston, S. C., recommended by J. M. Thomas and J. P. Cater; Peter Dubois, New York, recommended by G. T. Wogolom and H. Kroll. The next meeting will be held Dec. 8.

## Our Hand-made Cases

are constructed in the old reliable way, which is a pride to the Manufacturer, Dealer and Wearer.

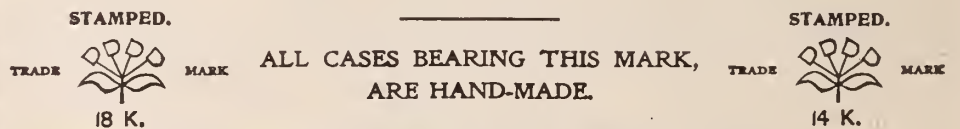

ALL CASES BEARING THIS MARK, ARE HAND-MADE.

Manufactured by **DUBOIS WATCH CASE CO.,**  
Makers of **SOLID GOLD CASES.**

21 and 23 Maiden Lane, New York.

WATCHES OF PRECISION.

## MATHEY BROS., MATHEZ & CO.,

WATCHES DEMAGNETIZED.



MANUFACTURERS AND IMPORTERS OF

Superior Plain and Complicated

## WATCHES AND MOVEMENTS.

Small Lever Watches a Specialty.



10 SIZE MOVEMENTS. BRASSUS, SWITZERLAND. 21 & 23 MAIDEN LANE, N. Y.

10 SIZE SPLITS.



# “Elf”

*A Special Line of Hand-Engraved,  
Bassine, Hunting-Case Watches —*

*The Same Designs  
in Open Face.*

*New This Season !*

THE Tiniest, Daintiest Line of Hunting Cases on the market for the Christmas season. The movement is the well known “Elf,” nickel damaskeened, with 12 jewels. The cases, of 14 k. solid gold, with a 25-year guarantee, are HAND-ENGRAVED—the very highest class of work that can be put on them. The Hunting-Case feature was never more exquisitely brought out, and every watch in the line is sure to command the attention and admiration of all holiday shoppers. We have taken especial care to have the line very choice, and in such variety and range of prices that every taste and purse may be met—the prices being very much lower than it could be supposed these watches could be sold

for, and yet there is a good profit for the dealer.

Nothing quite so fills the bill for a Christmas gift as a dainty, attractive watch. It's always in style—always in the best of taste—always a most welcome present.

Be sure you have a sufficient stock to meet your Christmas demands. We have as full a stock of these watches as it was possible to make, but the demand for this class of goods is so unprecedented, as all dealers know, that the stock won't last long.

## THE NEW ENGLAND WATCH CO.,

Waterbury, Conn.



# A. & B.

## HEADQUARTERS

FOR

## Waltham Watches

EVERY GRADE.

## AVERY & BROWN,

68 Nassau St., New York.

### CASH OFFERS.

If at any time you have offered to you by your customers any Jewelry containing diamonds, pearls or other precious stones and you do not care to buy them yourself, send them to us and we will submit an IMMEDIATE CASH OFFER. Trade and Bank References if desired. Established 1880. Correspondence solicited.

CHARLES S. CROSSMAN & CO.,  
3 Maiden Lane, New York.

### Baldwin, Miller & Co. Lose Two Valuable Employees by Death.

INDIANAPOLIS, Ind., Nov. 2.—The firm of Baldwin, Miller & Co. met with severe loss by the death on the same day, Oct. 31, of Oscar Derndinger, traveling representative, and Miss M. A. Moore, for many years employed in the office and well known to the trade and traveling men.

Mr. Derndinger was born in Offenburg, Baden, Germany, in 1845. He had been ill of typhoid fever for seven weeks. For five years he had visited the Indiana trade for Baldwin, Miller & Co., and was considered a personal friend by most of his trade. At one time he traveled for C. H. Knights & Co., Chicago. Mr. Derndinger was an honest, hard working, honorable man, whose place it will be hard to fill. He leaves a wife and one daughter. The funeral took place to-day, among the pall-bearers being Silas Baldwin, of Baldwin, Miller & Co.; Smith Nichols, of S. T. Nichols & Co., and Gus Craft, of A. P. Craft & Co.

### Decision in Reference to Missouri's Store Tax Law.

ST. LOUIS, Mo., Nov. 2.—A decision was handed down by Judge Wm. Zachritz, of Circuit Court No. 4, on Oct. 30, relative to the temporary injunction asked for by the department stores against the bill popularly known as the "Anti-Department

Store bill." In the decision the constitutionality of the law was not touched upon, but he held the Court could not pass upon a criminal statute, the Judge holding it to be such a law. He intimated that the complainants had a remedy at law if the bill was illegal by an action to recover damages for any injury sustained, and he therefore refused the temporary injunction asked for. The case has gone to the State Supreme Court and will be argued there on Nov. 16.

### Meeting of Creditors of George W. Biggs & Co.

PITTSBURGH, Pa., Nov. 3.—The meeting of George W. Biggs & Co.'s creditors was held on Tuesday, Oct. 31. The majority of the creditors were represented by their attorney, Frank Stoner, a brother of J. M. Stoner, Jr., who was elected trustee. An examination of the bankrupt firm will be held on Tuesday, Nov. 7. Henry Terheyden, who purchased the Biggs stock, and J. M. Stoner, Jr., are in New York. A rumor is current that Mr. Terheyden will occupy the store of the bankrupt firm, but no confirmation of the report could be made owing to his absence from the city.

Fred Carl, Elva, Mich., is seeking a location in the northern part of the State for a jewelry store.

**CROWN 14 K  
FILLED CASES**



**GUARANTEED  
FOR  
25 YEARS**

## Don't Deceive Yourself

when offered greater discounts that you are buying your goods at a lower figure.

### Crown 14 K. and Lion 10 K. Gold-Filled Cases

are sold at a net list subject to cash discount only.

Guarantees on

## Crown and Lion

cases mean exactly what they state.

**A New Case** of equal grade given **without charge** or conditions of any kind. That's plain, straightforward business.

**Crown and Lion Cases are**

**Sold by All Jobbers.**

**LION 10 K  
FILLED CASES**



**GUARANTEED  
FOR  
20 YEARS**



**The Employes' Silver Plate Company of Middletown Assuming Form.**

MIDDLETOWN, Conn., Nov. 4.—The Middletown Silver Co. have filed articles of incorporation with the town clerk. This new company resulted as an outcome of the deal whereby the Middletown Plate Co. were absorbed by the International Silver Co. The incorporators of the Middletown Silver Co. are largely former employes of the old plate company.

The engine in the factory of the new concern was started this week for the first time. It was found to work perfectly and as smoothly as could be desired. A few men are already at work in the factory, and a large number of castings have been made in preparation for beginning work in earnest. The company have considerable more preparatory work to do before they will feel firmly established, and it may be several weeks before any goods will be placed on the market.

The capital stock of the Middletown Silver Co., as shown in the articles of incorporation, is \$10,000 in shares of \$25 each, 20 per cent of which has been paid in. A majority of the directors are Charles H. Savage, Elbridge S. Ferree, C. V. Schram, C. J. Bright and William L. Martin.

Harry Reisinger, of Indianapolis, Ind., has been found guilty at Connersville, Ind., of knowingly receiving stolen goods. The prosecution grew out of the theft of jewelry from W. C. Klein's jewelry store, Connersville.



**Our New... Jewel Case**



has been pronounced by competent judges the best in size, shape, workmanship and fitting, in the market.

**Roy Watch Case Co.,**

Makers of **SOLID GOLD CASES,**

21 Maiden Lane,

New York.



**"OMEGA" WATCHES.**

**NONE BETTER MADE. OVER 1,000,000 IN USE.**

We want ALL LEADING Jewelers to know that the "OMEGAS" are the best watches for you to handle.

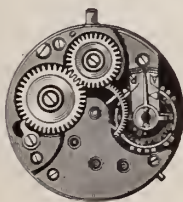

FINE ANCHOR MOVEMENT, 10 LIGNE, FULL JEWELLED—FITTED IN 14 AND 18K. O. F. CASES, SMOOTH AND FANCY ENAMELED CASES. GOOD SELLERS FOR FINE TRADE.

SEND FOR PRICE-LIST.



Pendant Set. 12, 14 and 16 Size. Made in Gun Metal, Silver, Gold Filled and Solid Gold Cases.

BECAUSE—They are ACCURATE timepieces.  
BECAUSE—They are SOLD only to the TRADE.  
BECAUSE—They give SATISFACTION to your CUSTOMERS.  
BECAUSE—They are PROFITABLE, as no prices are advertised in any journal.

The "OMEGAS" are Pendant Set, fit 0, 12 and 16 size Waltham cases, and are made in 6 different grades, as follows:

7 Jewels, Expansion Balance, Double Roller, Nickelized.

15 Jewels, Expansion Balance, Double Roller, Nickelized.

15 Jewels, Expansion Balance, Double Roller, Nickel, Pat. Reg.

17 Jewels, Expansion Balance, Double Roller, Nickel, Pat. Reg., adjusted.

17 Jewels, Expansion Balance, Double Roller, Nickel, adjusted to 5 positions.

21 Jewels, Expansion Balance, Double Roller, Nickel, adjusted to 5 positions.



Pendant Set. 0 Size. WITH SECOND HAND.

Warranted Fine Timepieces. ALL PARTS INTERCHANGEABLE

Above made to order with dealer's name if desired.

**E. E. ROBERT, 3 Maiden Lane, New York; CROSS & BEGUELIN, 17 Maiden Lane, New York, Selling Agents.**

**Death of Alfred M. Weinberg.**

The many friends of Alfred M. Weinberg throughout Maiden Lane, New York, were surprised and shocked Saturday to hear the news that he had died suddenly at his home, 474 Central Park West, the night before.

Mr. Weinberg, who was a member of the firm of Low, Weinberg & Co., importers of diamonds, 37 Maiden Lane, had been seen around the district only a couple of days before, so that the news of his death was at first hardly credited. On Thursday he claimed to be feeling ill before he went home, and Friday was attacked with pneumonia. He rapidly grew worse and died during the evening.

There was probably no more popular or better known jeweler in the Lane than

"Al." Weinberg, as he was familiarly styled among his associates. He was born 40 years ago, and started in the jewelry trade at an early age. His first position of importance was as bookkeeper for H. Oppenheimer & Co., Chicago, Ill., and later, when A. Hirsch went out of that firm and formed the firm of A. Hirsch & Co., he went with him as partner and salesman. Mr. Weinberg started in business for himself in 1882 in Chicago, and eight years later he went to New York. In January, 1891, with his brother-in-law, Hugo Low, and B. Hyman, he formed the firm of Low, Weinberg & Hyman, which continued until January, 1894, when Mr. Hyman retired. Mr. Weinberg and Mr. Low then continued the business under the style of Low, Weinberg

& Co., and for the last few years had offices in the Lorsch building, 37-39 Maiden Lane.

Mr. Weinberg had many strong friends throughout the trade, especially among his customers in the west, in which territory he traveled for a number of years. He was unmarried and is survived by his sister, Mrs. Hugo Low, with whom he lived, and his brother, E. M. Weinberg.

The remains will be cremated at 11 o'clock to-day, and the ashes will be taken to Chicago.

**Interesting Exhibition of Gold and Silver Work.**

A special exhibit of articles of gold and silver was made last week by the National Art Club, at the opening of their club house, at 37 W. 34th St., New York. This collection will be on view for a fortnight, and non-members who desire to see it can obtain tickets from the secretary or from members.

Among the objects shown are a case of old Dutch, French and German silver, lent by S. P. Avery, and another filled with Tartar silver ornaments, Russian icons and other objects, collected by George Kennan while making his investigations of the prison system of Russia and Siberia. The latter are lent by Alexander W. Drake, of the Century Company. Several prize plaques and trophies are from the workshop of Theodore B. Starr, together with a reduction in silver from the bronze statue of Diana, by Frederick MacMonnies. A case of Oriental objects, contributed by Dikran G. Kelekian, includes two Byzantine enameled crosses, set with coral and pearl, Armenian girdle clasps, an old Armenian mitre in silver, and a chalice from the Armenian Church of St. Thomas, with an inscription in Armenian of the 17th century.

Among the modern silver objects are bowls and yachting trophies. Wax and clay models for objects in gold and silver, by Henry Linder, are also exhibited. The officers of the society are George B. Post, president; Charles De Kay, secretary and managing director; Spencer Trask, treasurer. Charles R. Lamb is chairman of the Exhibition Committee; Franklin Colby, of the House Committee, and Richard Watson Gilder, of the Library Committee. The club, which has over 1,100 members, is open to both women and men, and its membership already includes more than 100 women. The club will have exhibitions of American art, potteries, leather, ivory and wood carving, silks, etc., in the course of the Winter.

**Barre Bros. Co. Buy the Levy & Michaels Stock.**

HALIFAX, N. S., Nov. 3.—The big jewelry stock of Levy & Michaels, which was sold to H. B. Clarke, several weeks ago, at auction for 46 cents on the dollar, has again changed hands. To-day Mr. Clarke sold out to Barre Bros. Co., of Montreal and Winnipeg. The new firm took immediate possession. They intend to sell the stock at bargain prices.

It is the intention of the Messrs. Barre to get rid of the present stock as soon as possible and open up a first class retail and manufacturing jewelry establishment. They will fit the store up anew.

**Another Victor.**

When the crucial test comes, when quality tells, side by side with the conquerors Concord and Raleigh stands

**THE BOSTON.**

O size, 3 rows of pearls, made in Montauk, 20 years' guarantee, and 14 F.K., 25 years' guarantee.

**Joseph Fahys & Co.,**

Established 1857.

FAHYS BUILDING, NEW YORK.

**Rites in Honor of the Late Martin S. Smith.**

DETROIT, Mich., Nov. 3.—The funeral of Martin S. Smith was held on Tuesday from the family residence, 120 Lafayette Ave. As a tribute to the departure of an honored citizen it was made memorable by the presence of many old and distin-

acterized by the same simplicity as at the house. The active bearers were Howard Meredith, Clarence Carpenter, Hamilton Dey, J. C. McCaul, John Millen, F. D. C. Hinchman, C. B. Hull and John H. Avery. The honorary pallbearers were Gen. R. A. Alger, W. A. Moore, George H. Russell, R. W. Gillett, Thos. S. McGraw, F. J. Hecker, Geo H. Barbour, G. W. Bissell, G. H. Hopkins, H. B. Ledyard, W. E. Quinby, J. T. Kenna, Homer Warren, Geo. B. Startwell, Silas B. Coleman, A. Y. Ladue, E. T. Hance, Henry Russel, H. M. Campbell, Geo. C. Langdon, C. L. Freer, W. H. Elliott, Allan Sheldon and E. Y. Swift.

Mr. Smith died from an operation on the kidneys, performed for an abscess, several months ago. Mr. Smith was a man of diversified interests and found his chief pleasure in a personal management of his great business. He kept closely in touch with the affairs of all corporations of which he was an officer or director. As a result of his activity Mr. Smith was always regarded as a most valuable man in every enterprise with which he was connected. It was this element in his nature that resulted in the noted jewelry firm of M. S. Smith & Co., which was successful until 1890, when the business passed into the hands of F. G. Smith, Sons & Co. and ceased to have his personal help and cash.

M. S. Smith was born Nov. 12, 1834, at Lima, Livingston county, N. Y. Ten years later the family came to Michigan and located near Pontiac. Here he was a newspaper man and dry goods clerk. He came to Detroit in 1851 and clerked in a jewelry store for eight years. In 1859 he purchased the stock of his former employers, largely on credit. His store was then at 51 Woodward Ave., and he soon made the firm of M. S. Smith & Co. an important factor in Detroit's business life. In 1863 the business was removed to the corner of Jefferson and Woodward Aves., where it remained for 20 years, finally being removed to the corner of State St. and Woodward Ave. The business was incorporated in 1879, when M. S. Smith retired from the active management. In 1874, five years previous, he became a member of the firm of Alger, Smith & Co.

There is no better way of demonstrating the magnitude of the business interests which more or less came under his personal supervision than to recite the official



THE LATE MARTIN S. SMITH.

guished friends and by the utterance of reverent eulogy and tender religious feeling. Numerous floral designs expressed mute sympathy. The social, professional and commercial life of Detroit was represented, as well as the Municipal and Federal governments. Gen. R. A. Alger, his business partner; Mayor Maybury, Senator McMillan, ex-Senator Thos. W. Palmer, ex-Postmaster Don M. Dickinson, Customs Collector Rich and Internal Revenue Collector Wright were prominent among the assembly. The Old Guard of the Knights Templar, 25 in number, were the only attendants who formally appeared, and only one member wore the decoration of the order, it being the wish of the family that the ceremony be rigidly unpretentious. Rev. John Reid conducted the services, which were simple and beautiful. There was no music; only words of Scriptural consolation, of personal tribute and prayer. At the close the words of the song "Nearer My God to Thee" were read.

Only the active pallbearers accompanied the family to the cemetery, where the burial was private. The services there were char-

# The Superlative Beauty

of Bell Gold-Filled Watch Cases needs but little extolling. It speaks for itself.



If you are not aware of the many advantages that accrue to you from the sale of Bell Cases, write for information.

**Buy of the Maker.**

**THE BELL WATCH CASE CO.,**

**CINCINNATI, OHIO.**

SCIENTIFIC RUBIES  
OPALS  
OLIVINES

CATSEYES | SAPPHIRES | DIAMONDS | RUBIES | EMERALDS | PEARLS | PEARL NECKS | PEARL ROPES

**PEARLS, DRILLED AND UNDRILLED.  
PEARL ROPES, NECKS and COLLARETTES.**

**We are buyers of American Pearls.**

LONDON: **JOSEPH FRANKEL'S SONS,** 68 Nassau Street, NEW YORK.  
19-20 Holborn Viaduct.

TELEPHONE, 3899 CORTLANDT.

FANCY COLORED DIAMONDS and GEMS in PEARLS and PRECIOUS STONES.

Pearl Collarettes, mounted with Diamond Bars.

**DIAMONDS.**  
**Wm. S. Hedges & Co.,**  
 IMPORTERS OF  
**Diamonds and Precious Stones.**  
**DIAMOND JEWELRY.**  
**170 Broadway, New York.**  
 26 Holborn Viaduct, London.

*Oppenheimer Bros. & Veith,*

*Importers and Cutters of*

*Diamonds*

*Dealers in*

*Watches,*

*Cor. Nassau and John Streets,*  
 (PRESCOTT BUILDING.)

*....New York....*

*Amsteraam,*  
*2 Tulp Straat.*

*London,*  
*45 Holborn Viaduct.*

positions which are set down against his name in the many corporations in which he was a stockholder. He was vice-president and treasurer of Alger, Smith & Co., lumbermen; vice-president and treasurer of the Manistique Lumber Co.; president of the Manistique Railway Co., and of the Duluth & Northern Railway Co.; president of the American National Exchange bank of Detroit; vice-president of the States Saving bank; president of the Michigan Condensed Milk Co.; director of the Union Trust Co.; treasurer of the Woodmere Cemetery Association, and was connected with a half dozen other commercial enterprises that have been wound up or have passed into the hands of others.

As a business man Mr. Smith was a model of method and regularity, of great energy, quick perception and rapid in judgment. He always took a lively interest in his employes, treating them with consideration. He gave liberally to all public and charitable enterprises. He was a Knight Templar and always prominently identified with Masonic work. Mr. Smith's principal diversion was his handsome steam yacht *Vita*. He married Mary E. Judson, of Detroit, in 1862, who survives him. He leaves one daughter, Miss Helen Smith. Two brothers survive him, Frank G. Smith, of Detroit, and T. A. Smith, of Pontiac.

The fortune of Mr. Smith is variously estimated, but the correct figure is very close to \$2,000,000. In the firm of Alger, Smith & Co., the Manistique Lumber Co., Michigan Condensed Milk Co. and the Manistique Railroad Co. he had nearly \$1,500,000 invested. The rest of his wealth was in the form of bank stocks and other investments.

#### Dissensions Among the Proprietors of the Worcester Optical Co.

WORCESTER, Mass., Nov. 4.—Arthur W. Tiffany, formerly superintendent of the Worcester Optical Co. and engaged in business on Main St., Tuesday commenced suit against the Worcester Optical Co., through his counsel, Chas. C. Milton, placing damages at \$3,000, on an alleged breach of contract. President S. B. Huselman says the company will contest the claim to the last ditch. Mr. Tiffany asks for \$600 for his services as superintendent, \$570 for commission on stock sold, and an additional sum for expenses.

The Worcester Optical Co. were organized in June, and on the 26th of that month the factory of the Windle Cycle Co. was purchased as the foundation of the company's plant. Recently there have been dissensions among the original proprietors of the company. A. W. Tiffany, O. C. Thayer and John Elm have demanded for their services in promoting the concern, the first \$600, and the other two \$300 each. The stockholders refuse to pay the claims. The company recently raised the mortgage on the building held by William Hart. Samuel W. Wiley was elected manager and superintendent of the company, and W. C. Hoar was elected a director.

G. W. Marcum, of Horse Cave, Ky., has gone to Bartow, Fla. He will open a jewelry store there in the shop of W. R. Claxton.

**MOUNT & WOODHULL,** FORMERLY WITH LATE FIRM OF  
 RANDEL, BAREMORE & BILLINGS,  
 .... IMPORTERS OF ....  
**Diamonds, Other Precious Stones, Pearls, Etc.,**  
**Makers of fine DIAMOND JEWELRY,**  
 26 MAIDEN LANE (SOUTHWEST CORNER  
 NASSAU STREET), NEW YORK.

JOHN C. MOUNT.

ADDISON W. WOODHULL.

**FOX & CO., Lapidaries** and Importers  
 of  
**....Precious Stones.**  
 Now at.....  
 22 JOHN STREET,  
 NEW YORK.  
 Cutters of American Gems and Fine Miniature Glasses  
 Fine Stone Seal Engraving  
 (Crests, Monograms, etc.), a Specialty.

## The Bowden Rings

ARE COMPLETE IN VARIETY, CORRECT  
 IN QUALITY AND PERFECT IN FINISH.  
 WE MAKE EVERY VARIETY OF FINGER  
 RINGS

**J. B. BOWDEN & Co.,**

1 MAIDEN LANE,

NEW YORK.

**Precious Stones: London Market**

HATTON GARDEN, London, Eng.,  
Oct. 28, 1899.

*The Diamond Market:* Beyond the two 5 per cent rises of Oct. 7 and 16, already announced in THE CIRCULAR, there is, as far as I can ascertain, no change in price of rough. The closest scrutiny of the cables from Kimberley fails to elicit any definite news of the condition of the mines. The mine mounds are being used by the artillery, and many of the employes appear to have been enrolled for defensive purposes; it is difficult to suppose, therefore, that production is going on.

The new Bultfontein Mine, which is also in West Griqualand and has been producing fairly for some time, has been shut down, but the employes have been retained.

The opinion that despite apparent scarcity of rough there is still a considerable quantity in the market is held in reliable quarters, but some merchants maintain that the supply is practically exhausted. A statement is published that only large parcels of rough are to be had—£5,000 and upwards. It is, I believe, a fact that many small dealers have been driven out of the trade in rough, and that the number is decreasing still more.

The rise in cut stones—comparing prices three months ago with quotations for parcels of melée under offer to-day—is probably 40 per cent to 50 per cent. £5 a karat stuff is offered at £7 to £8, and better assortments formerly priced at £8 would not be “sealed” to-day at under £11 or £12. R. F.

**Permanent Organization of the Oregon Association of Opticians.**

PORTLAND, Ore., Oct. 31.—Permanent organization of the Oregon Association of Opticians was effected at a meeting held on the night of Oct. 24. The following officers were elected: President, J. O. Watts, of Eugene; first vice-president, H. S. Butterfield, of Portland; second vice-president, G. Heitkemper, of Portland; treasurer, W. E. Garretson, of The Dalles; secretary, C. L. Haynes, of Portland. The executive committee is composed of L. E. Capps, of Portland; Dr. F. W. Binford, of Newberg; Charles F. Torrance, of Forest Grove, and E. O. Mattern, of Portland.

The meeting was largely attended and was characterized by enthusiasm and harmony. The next meeting of the association will be held in Portland on the third Monday in January, at which a paper on “Heterophoria” will be read by Dr. Charles F. Torrance; one on “Retinoscopy,” by Dr. Phillips, and one on “Optics in General,” by Dr. Capps.

The purpose for which this association is constituted is the establishment and maintenance of all legitimate optical trade in the State of Oregon, and the interchange and discussion of optical, social and business matters, and the encouragement of literature and science pertaining to optics. Meetings will be held four times each year in different cities of the State, when scientific papers will be read and discussed.

A. P. Neal & Son, Rantoul, Ill., have added a jewelry stock to their store.

ESTABLISHED 1840.

**Chester Billings & Son,**

Successors to **RANDEL, BAREMORE & BILLINGS,**  
IMPORTERS OF

1840 RANDEL & BAREMORE.  
1866 RANDEL, BAREMORE & CO.  
1880 RANDEL, BAREMORE & BILLINGS.

**DIAMONDS**

OTHER PRECIOUS STONES AND PEARLS.

58 Nassau Street,  
29 Maiden Lane, 22 Holborn Viaduct,  
NEW YORK. LONDON, E. C.

DIAMOND JEWELRY.

...ESTABLISHED 1841...

A. CARTER. C. E. HASTINGS. G. R. HOWE. W. T. CARTER. W. T. GOUGH.

**Carter, Hastings & Howe,**

TRADE  MARK.

MANUFACTURERS OF

**Gold Jewelry,**

9, 11, 13 MAIDEN LANE, NEW YORK.

FACTORY, NEWARK, N. J.

**Pearl Purchasers**

will find it to their advantage to inspect the stock of

**Fred. W. Lewis & Co.,**

the largest on this side of the Atlantic.

No. 1 MAIDEN LANE (Cushman Building), NEW YORK.

**John F. Saunders,** Cutter and Importer of

**DIAMONDS** AND OTHER  
PRECIOUS STONES.

FINE PEARLS A SPECIALTY.

68 Nassau St., cor. John St., Sheldon Building,  
Room 16, NEW YORK.

## PEARLS.

## Profitable Goods.

Our stock of Pearls and Precious Stones is made up of profitable goods—profitable to the dealer as well as to ourselves. They are purchased by us with a view of satisfying the dealer completely; an obligation of which we are ever careful. Hence, our customers receive complete value, dollar for dollar.

### Alfred H. Smith & Co.,

182 Broadway, N. Y.

CHICAGO.

LONDON.

## DIAMONDS

And Other Precious Stones.

## "The Pearl House."



PEARLS PHOTOGRAPHED EXACT SIZE.

Our recent shipments of Pearls are worthy of most careful consideration. We have no salesmen; call or drop us a line.

## Eisenmann Bros.,

Importers of Pearls and Precious Stones,

21 and 23 Maiden Lane, = = NEW YORK.

Paris: 3 Rue Saint Georges.

## Tariff Decisions.

### "WATCH GLASSES" FOR CHEMISTS' USE.

An odd protest decided last week by the Board of Classification of the United States General Appraisers was that of Chas. H. Wyman & Co., St. Louis, Mo., from the assessment of 60 per cent on glass covers for jars, commercially known as "watch glasses." The local appraiser reported that the merchandise was not intended for watches, but is used by chemists in laboratory work, while the importers contended that inasmuch as the articles are known as "watch glasses," they are dutiable as parts of clocks or watches at 40 per cent. This claim by the protestants the Board characterize as so absurd and manifestly untenable as to require no discussion. The protest is, therefore, overruled.

### RE-APPRAISEMENTS.

Among the re-appraisements by full Boards was:

Clocks, from G. Almond, Halifax, May 16, 1899: One old oak 30-hour clock, entered at 3.10 f., advanced to 5 f.; 1 old oak 30-hour clock, entered at 3 f., advanced to 4.10 f.; old oak 30-hour clock, entered at 3 f., advanced to 4.10 f.

### Canadian Merchants and the Conglomerate Store Question.

TORONTO, Can., Nov. 3.—Active preparations are on foot for a vigorous legislative campaign against the department stores. The Provincial Government last Spring, when the bill to regulate department stores was withdrawn, promised to appoint an investigating committee at the next session of the Legislature to consider the whole question. In order to have everything in readiness to submit their case to the House and fix upon a plan of campaign, the Retail Merchants' Association of Canada will hold a Convention in Toronto on or about Dec. 5, at which over 200 delegates are expected to be present, including representatives of the Pacific coast, the Northwest and the Maritime Provinces. Since last Spring information from all available sources as to the most effective methods of dealing with the question in other countries has been carefully compiled and the systems adopted or proposed in some of the United States, as well as in Germany, France, Belgium and Switzerland will be submitted to the convention.

I. B. Johnston, Toronto, a member of the Executive Committee, has made a full examination into the British system of income and personalty taxation which may have a bearing on the problem. E. M. Trowern, secretary, will give an account of his trip to St. Louis and of the Missouri anti-department store movement, and A. H. Gibbard, who has just returned from the Pacific coast, will detail from personal observation the effect of these large stores on the trade of the Northwest and British Columbia.

The removal of E. Bachmann from Milwaukee, Wis., to Memphis, Tenn., was on account of his wife's health. His new store at 107 Beale St., Memphis, was opened for business Saturday last.

**Importations at the Port of New York.**

*Weeks Ended Nov. 4, 1898, and Nov. 3, 1899.*

China, Glass and Earthen Ware:	1898.	1899.
China .....	\$83,852	\$77,017
Earthenware .....	19,055	34,441
Glassware .....	13,842	34,134
<b>Instruments:</b>		
Musical .....	9,117	15,058
Optical .....	3,343	11,709
Philosophical .....	5,179	670
<b>Jewelry, etc.:</b>		
Jewelry .....	6,548	9,879
Precious stones .....	182,407	334,074
Watches .....	19,274	22,500
<b>Metals, etc.:</b>		
Bronzes .....	4,303	6,687
Cutlery .....	12,587	30,962
Dutch metal .....	2,839	7,665
Platina .....	35,049	28,387
Plated ware .....	1,462	1,419
Silver ware .....	315	1,928
<b>Miscellaneous:</b>		
Alabaster ornaments .....	242	156
Amber .....	7,092	.....
Beads .....	4,297	723
Fancy goods .....	4,475	5,110
Clocks .....	8,821	7,306
Fans .....	7,895	12,696
Ivory .....	.....	5,632
Ivory, manufactures of.....	845	834
Marble, manufactures of.....	8,340	8,109
Statuary .....	3,352	2,553

**Charles P. Goodman Stricken While Auctioneering Off His Stock.**

PHILADELPHIA, Pa., Nov. 3.—Charles P. Goodman, a retail jeweler, for years established at 60 N. 8th St., while selling out at auction Wednesday, was attacked with heart failure and died instantly. Mr. Goodman conducted the sales himself. On Wednesday morning there was quite a crowd in his little store. Taking up an article of bric-à-brac, Mr. Goodman, who was standing on a box behind the counter, asked for an offer. The bidding was lively and Mr. Goodman urged on the prospective buyers. He was crying "Going! Going—!" when the hand which held the article fell to his side, and after a few spasmodic gasps, he fell from the box on which he was standing to the floor. Several employes were at his side at once. A patrol wagon was summoned, but the police pronounced him dead. The body was removed to his home at 5229 Jefferson St., from which place it was buried Saturday.

Mr. Goodman had been in the jewelry business all his life. He was 42 years of age and widely known in the trade.

**Robber Works Successfully in Matt Miller's Store.**

JOPLIN, Mo., Nov. 1.—A diamond robbery was perpetrated at Matt Miller's jewelry establishment a few evenings ago. While Mr. Miller was at supper a stranger stepped in and asked to be shown a valuable pair of diamond ear rings, claiming that he had talked with Mr. Miller about purchasing them several days before. The jeweler, Mr. Watkins, produced the diamonds from the showcase, and after the party had examined them for a few minutes he asked to be shown a stud. The latter was also produced, the ear rings being left on the showcase. The stud did not please the party, and as Mr. Watkins was replacing it in the showcase the thief quickly snatched the ear rings and ran out of doors. As soon as Mr. Watkins could close the showcase he started in pursuit, but the thief ran through a saloon and made his escape in the dark alley.

**NISSEN**



We carry the largest, finest and most complete line of Mounted Diamond Jewelry of any house in America.



**This is How**

the good times have affected the Diamond business.

Those who were able to buy Diamonds a year ago are now buying higher-priced Diamond pieces.

Those who a year ago had to be content with an ordinary piece

of gold jewelry are this year buying Diamond Jewelry.

As we have remarked before, "Our line of Diamond Jewelry is the successful line of the season."

**Kohne & Co**

9.11.13 MAIDEN LANE.  
NEW YORK.

OTTO K. TREIBS. PAUL E. TREIBS.

**TREIBS BROS.,**  
68 Nassau St., New York.

CUTTERS AND IMPORTERS OF

**Opals.**

**F. E. TREIBS,**  
Oberstein, Germany.

ESTABLISHED 1842.

HERMANN TREIBS. ALBERT TREIBS.  
EMIL TREIBS.

**SILVER NOVELTIES**

**SIMMONS & PAYE,**  
"The Souvenir House,"  
129 Eddy St., Providence, R. I.,  
will mail to any jeweler on request a copy of their latest catalogue, illustrating manicure goods, toilet goods, and silver-mounted glass goods.

**Commercial Congress Closed.**

**Matters of Interest to Jewelers from the National Export Exposition.**

PHILADELPHIA, Pa., Nov. 4.—With three hearty cheers for Director-General Wilson, proposed by an English delegate, the sessions of the first International Commercial Congress ever held were brought to an end at the National Export Exposition in this city last Wednesday. On every hand are heard assurances that the Congress has been of incalculable advantage to the trade circles of the whole world and particularly to those of America. Work was accomplished that never could have been accomplished under any other circumstances and a much needed impetus and stimulus given to international trade.

THE CIRCULAR has already reported the opinions of some of the leading exhibitors of jewelry and optical goods as to the success of the Congress, and all the leading manufacturers of jewelry, cases and optical goods in this city have sold goods to delegates from countries hitherto totally unknown to them.

The number of delegates who attended the Congress was 350, Australia furnishing the largest quota, 20 representatives from that country being present. Of the delegates the largest number spoke English. Delegates were present from 53 foreign countries, one of them traveling 18,500 miles, from Freemantle, West Australia, to reach Philadelphia.

All of the visitors think the Congress accomplished a great work. Prof. Mario Salvini, delegate from the Chambers of Com-

merce and Arts, Florence and Bologna, and from the Association of Industries and Commerce, Florence, said to THE CIRCULAR representative: "I go back to Italy taking with me the impression of the great utility of the Congress, the product of an intelligent and active mind which is ever exerting its influence for the increase of international commercial relations. I hope the conclusions approved by the Congress will be adopted in the interest of the relations and freedom of all nations." Mr. Salvini is a jeweler and dealer in objects of art. Delegates from Florence and other cities echoed the sentiments of Prof. Salvini.

At the opening of the last session Director-General Wilson was presented with a handsome solid silver tea and coffee set as a testimonial of the esteem of all the delegates, both foreign and American, who were grateful to Dr. Wilson for bringing them all together. The service was only decided upon a few days ago and the contract was given to the Bailey, Banks & Biddle Co. Sir Horace Tozer, of Australia, made the presentation speech and Mario Salvini, of Italy, added a few words of praise. The service is a handsome one of six pieces, the pitcher bearing the inscription:

"To Dr. Wm. P. Wilson, Director of the Philadelphia Commercial Museum, and Chief Organizer of the first International Commercial Congress, held at Philadelphia, in October, 1899; with assurance of sincere gratitude for his uniform courtesy and in recognition of his extraordinary services to international commerce. From the foreign and American delegates."

B. R. Ford will remove from Cascade, Wis., to Reedsville, Wis.

ALVIN L. STRASBURGER. SOL. KAISER.

Established 1849.

**LOUIS STRASBURGER'S SON & CO.**

9-13 MAIDEN LANE, NEW YORK.

**...DIAMONDS...**

**PEARLS, SAPPHIRES, RUBIES,**  
**EMERALDS, MARQUIS DIAMONDS.**

CHICAGO, ILL., 103 State Street. PARIS, 25 Boulevard Haussmann.



**Montgomery's New Dial for Railroad Watches.**

TOPEKA, Kan., Nov. 1.—H. S. Montgomery, general watch inspector of the Santa Fé, has devised a watch dial to prevent mistakes in reading time. On the new dial the minutes are numbered in heavy plain black figures from 1 to 60. It has been the custom for watch factories to furnish dials with large black figures of the hours, and call them railroad dials. The minutes are the important factors, and the dial referred to brings out the minutes sharp and prominently, not only in plain lines, but in plain figures which strike the eye instantly, leaving no possibility for guesswork or mistake.

The management of the Santa Fé promptly endorsed the dial and adopted it for use on its system. Railroad men who have seen it are emphatic in their praise of its advantages. Mr. Montgomery has applied for patent on the device. The dial will be placed upon the company's standard clocks, such clocks having sweeps seconds-hand, its utility being equally as important on clocks as watches, which feature will be readily observed.

**C. W. Rodman Settles with the Insurance Companies.**

SLATER, Mo., Nov. 4.—The trustee for the estate of C. W. Rodman, bankrupt, has settled with the insurance companies—the smaller policies at 75 per cent and a little less and the larger policies bunched at 57½ per cent. This is regarded as a good settlement, in view of the fact that the fire was of incendiary origin and the insurance companies were willing to fight. An examination of Mr. Rodman by the referee, on Oct. 31, brought out that after the fire Mr. Rodman had very little money, so he sold several diamonds for \$400 which he had bought on credit for \$700 or more. He claims to have bought them in the belief that the insurance policies would be quickly settled, and said that he spent the proceeds in living expenses. The drafts will shortly all be in and the first dividend speedily declared.

**Jewelers' Gold Bars Withdrawn and Exchanged at New York.**

*Week ended Nov. 4, 1899.*

U. S. Assay Office report:

Gold bars exchanged for gold coin.....\$259,147.02  
Gold bars paid depositors..... 39,200.85

Total .....\$298,347.87  
Of this the gold bars exchanged for gold coin is reported by the Sub-Treasury as follows:

Oct. 30 .....	\$59,229
Oct. 31 .....	20,692
Nov. 1 .....	51,729
Nov. 2 .....	42,924
Nov. 3 .....	30,562
Nov. 4 .....	28,093

Total .....\$233,229

**Gifts for Men**



In 14-Karat Gold—ORNAMENTED WITH PRECIOUS STONES—and in Sterling Silver. Goods that appeal to refined people at all times. Made handsomely, heavy and exclusively for the Jewelry trade.

**Woods & Chatellier,**

Gold and Silversmiths.

860 Broadway, N. Y.

42-46 Hill St., Newark, N. J.

SLEEVE LINKS,

Moonstone, Amethyst, Carbuncle,  
Jade, Opal.

**GEO. O. STREET & SONS,**

24 JOHN ST., NEW YORK.

... Established 1837 ...



**EMPIRE COMBS. SIDE COMBS.**

GOLD AND JEWELLED ORNAMENTED.

SPECIALTIES IN ROMAN WORK.

**DAY, CLARK & Co.,**

MAKERS OF FINE JEWELRY,

23 MAIDEN LANE, N. Y.

**Stern Bros. & Co.,**

Cutters of ...

MANUFACTURERS OF

**DIAMONDS,**

Gold Rings and Thimbles,

68 NASSAU STREET, NEW YORK.

RING FACTORY, 33-43 GOLD STREET, NEW YORK.

LONDON OFFICE, 29 ELY PLACE.

DIAMOND-CUTTING WORKS, 142-146 W. 14TH ST., NEW YORK.

CHICAGO OFFICE, 149 STATE ST.

**RUBIES.**

**SAPPHIRES.**

**C. G. MALLIET & CO.,**

**EMERALDS.**

14 MAIDEN LANE, N. Y.

**DIAMONDS.**

**JAMES KAHN'S SONS,**

PARIS: 7 RUE CADET.

IMPORTERS AND CUTTERS OF DIAMONDS,

Amsterdam, 2 Tulp Straat.

12, 14 & 16 John St., New York.

## The Peabody Precious Stones.

Investigation of the Affidavits of A. Peabody Regarding the Gems Seized from Him.

No final decision had been rendered by Collector Bidwell of the Port of New York, Monday afternoon, up to the time when THE CIRCULAR went to press, in the case of the seizure of about \$15,000 worth of diamonds and precious stones from Adolph Peabody, as reported in THE CIRCULAR last week. As already told, these stones were obtained from Peabody and put into the hands of the Collector, who held them pending the investigation of the charge that they had been brought into this country by way of Canada and that no duty had been paid on them. Mr. Peabody filed

with the Collector affidavits tending to show that some of the goods were diamonds cut in this country, and that the other goods he had purchased here, and consequently when he brought them back to this country he did not believe that they were dutiable.

Deputy Collector Dudley S. Phelps said to a CIRCULAR reporter Monday afternoon that he had been investigating the affidavits submitted by Peabody, and that his work was about complete. There were, he said, among the goods, a large amount of diamonds which might have been cut here, and if Mr. Peabody's evidence was sufficiently strong to satisfy the Collector that they were the goods claimed to be identified in his affidavits they would be released. On the other hand, said Mr.

Phelps, there are also a number of packages of melée, rubies, garnets, pearls and opals which were not cut in this country, and even if they had been bought here were liable to duty on re-importation. Against these goods, he said, an action would undoubtedly be commenced to have them confiscated, and, pending that act, they would be held by the Collector. The only question at the present time, he said, was how much of the large diamonds could be identified as having been cut in this country.

When asked if any criminal action would be taken against Mr. Peabody, Mr. Phelps said that he did not think so, as there was nothing to show that Mr. Peabody was not honest in his claim that he believed the goods to be free of duty because they had previously been imported.

## Pearls.

Anticipating a large demand for pearls we made preparations during the past summer to meet it, with the result that to-day we can offer a well-selected stock, loose, and mounted by themselves, or in combination with diamonds.

Prices reasonable.

We also have a large stock of DIAMONDS and COLORED STONES.

**HAYDEN W. WHEELER & Co.,**

**TWO MAIDEN LANE, N. Y.**

50 HOLBORN VIADUCT, LONDON.

### Keep a Lookout for This Stout Woman and Her Friends.

SYRACUSE, N. Y., Nov. 5.—Yesterday afternoon at 12.45 o'clock a stranger entered the store of Leiter Bros., dealers in music, pianos and jewelry, 304 and 306 S. Salina St., and said he wished to look at music. Burton Michaels waited upon him and he stopped suddenly and declared he had forgotten the name of the song he had come for. Then he said he would step back to the store and ask the lady the name of the song. He left the store and returned a little later and gave the name of the song he desired, whereupon Mr. Michaels found it for him. He then asked him to play it for him. Mr. Michaels called another clerk to play the piece, noticing at the same time that two men who had come into the store about the time the stranger did were busy at the rear of the store looking at silver ware. When one of them had engaged the attention of the clerk who was waiting upon them, sufficiently, the other sauntered up to the center of the store and finally to the front. Mr. Michaels saw him go around the end of a counter to a show window, and suspecting something was wrong walked to the front of the store and met the fellow just as he came from the window, and asked him what he was doing there; what business he had behind the counter, anyway. The man made a confused reply, whereupon in some way a tray of diamond rings, which he had hidden under his coat, dropped to the floor.

Mr. Michaels tried to intercept the fellow, but a big, fat woman stood in the door and exclaimed in an apparently excited manner: "What on earth is the matter, anyway?" Then Mr. Michaels asked the elder Mr. Leiter to call the police. The man who was at the piano listening to the song being played, remarked: "I'll call them." Mr. Leiter demanded to know the whys and wherefores of calling the police, and when the firm had recovered their senses all three men and the big, fat woman had disappeared.

After a long time the police were notified. The big, fat woman was no doubt the accomplice of the men and it was to her that the diamonds were undoubtedly to be passed. The crooks answer the description of thieves who operated successfully in Buffalo two or three weeks ago, where they made off with a tray of diamonds.

# Don't be Deceived on your wants in **novelties** for your **Holiday Trade**

Don't delay your orders. Buy in liberal quantities. At our prices you can do a land office business.

PRICES QUOTED ARE NET CASH.



## DEWEY SALT AND PEPPER SET.

No. 103. Cut full size.

(Cut full size.) Cut Glass effect; Salt Dish, Tray and Pepper Shaker, with Sterling Silver Screw Top. The most beautiful, striking and useful article ever put on the market. Having but a limited quantity on hand, we respectfully urge you in placing orders early to insure prompt delivery.

No. 103. Price per dozen sets.....\$2.50.  
Sample set, 25c.

### TWO HOT SELLERS!

We purchased all the Pairpoint Mfg. Co. had of these Jewel and Collar Button Boxes. Take advantage of the Cut Prices by ordering early. No more after these are sold.



No. 105.

#### STAMP BOX.

(Cut full size.) Stamp Box. Quadruple silver plated, on fine, hard white metal, satin finish, raised ornaments both sides. Regular price, 15c.

No. 105. Our closing out price while they last, 9c, each, or \$1.00 per dozen, net cash.

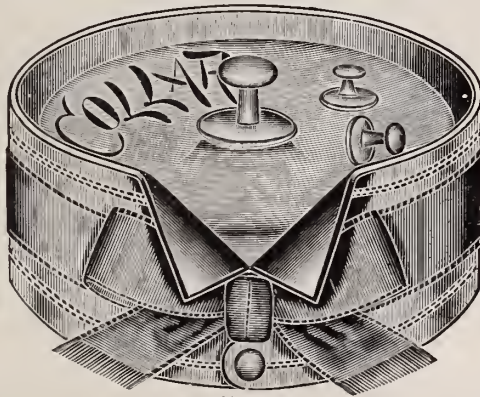

No. 104.

#### COLLAR BUTTON BOX.

(Cut full size.) Quadruple silver-plated, satin finish and bright cut engraved Box, artistically lined with colored satin, with colored silk ribbon bow around the collar. A very beautiful, odd and useful article.

No. 104. Regular price \$1.00. Our closing out price, while they last.....75c.

### A line of FANCY THERMOMETERS at less than cost to manufacture.

Having purchased the entire line of Thermometers from the Pairpoint Mfg. Co., at a closing out sale, we are going to give our customers an opportunity to avail themselves of this extraordinary bargain. These goods are all made of the finest quadruple silver-plated and finished white metal in either gold or silver. An assortment of patterns to suit the most fastidious.

Style No. 101 comes ornamented with golf stick (as shown in cut), base ball bat, ax, lawn tennis racket, oars, gun and game bag, etc.

All Thermometers guaranteed accurate and reliable. Illustrating these goods does not do them justice. They must be seen to be appreciated. Just the thing for holiday attractions. They are exceptional bargains; many of these patterns sold from \$1.00 to \$2.00 each. Don't miss taking advantage of this offer, and send your order at once, anticipating your Christmas wants, as we quote these prices while the stock lasts. No more after these are sold.

No. 101.....Each 55c  
Per dozen, assorted, \$6.00.



No. 101. (Cut full size.)



No. 107. The best yet. Fine sterling mounted comb, 925-1000 fine, guaranteed best comb in the market for the price. Cut full size. Each, net cash....33c. The above piece, with brush (price of brush, \$1.15), put up in a satin-lined, white glazed paper box, 15c, extra.

# A. C. BECKEN, 103 State St., Chicago, Ill.

**"THE AMERICAN BEAUTY"**



IN

**Sterling and Essex**

UNEQUALED.

**Hayden Mfg. Co.,**

**21-23 MAIDEN LANE,  
NEW YORK.**

**Boston.**

Herbert W. Richards has severed his connection with N. G. Wood & Sons.

E. F. Emery, formerly a foreman for the E. Howard Watch & Clock Co., has opened a new jewelry store in Windsor, Vt.

D. C. Percival will replace his Summer home at Marblehead with another residence, larger and handsomer than the present edifice.

The case of the trustees of estate of the late firm of George H. Richards, Jr., & Co., versus Robbins, Appleton & Co., has finally reached a hearing after many postponements.

Charles Harwood, of Harwood Bros., who has been ill the past fortnight with pneumonia, was somewhat improved at latest accounts, and hopes are entertained of his recovery.

Buyers in town the past week included: J. R. Roche, Eastport, Me.; E. F. Robinson, Ellsworth, Me.; H. S. Hewitt, Brockton; H. W. Jones, Freeport, Me.; W. S. Masten, Lyndonville, Vt.; George T. Springer, Westbrook, Me.; P. B. Guptill, Cherryfield, Me.; Dr. C. E. Mudgett, Fairfax, Vt.; J. M. Bacheider, Pittsfield, N. H.; A. L. Reed, Fall River.

Moses Van Dam, jeweler at 195 West Broadway, South Boston, was victimized Friday evening by a slick stranger, who got away with four watches which the proprietor placed before him in response to his request to be shown some ladies' gold watches. By the time Van Dam reached the door in his pursuit of the thief the latter had vanished from sight.

**Worcester, Mass.**

Laurence W. Pennington, manufacturing jeweler, has moved from 397 Main St. to 326 Main St.

A. W. Tiffany has invented a preparation to prevent the steaming and frosting over

of spectacles and eye-glasses. He has applied for a patent. He says one application of the preparation will last two days. It is a thin coating rubbed in the case which protects the glasses.

**Connecticut.**

The Charles Parker Co., Meriden, have received news of the death of William M. Fairbien, their principal western representative.

A. B. Ryan, formerly a jeweler of Middletown but later president of Electro-Marine Salts Co., the fraudulent enterprise conceived and promoted by the Rev. P. F. Jernegan, is now engaged in the real estate business in Boston.

Business at the Shelton factory of the International Silver Co. is very brisk, nearly all the departments being kept working from 7 A. M. until 9 and 10 o'clock P. M. The quantity of goods turned out this season has seldom been equaled at this factory.

The C. B. Barker Mfg. Co., Brooklyn, N. Y., and 56 Warren St., New York, signed a lease of the plant of the former Baldwin & Lamkin shoe factory at Milford, Conn., on Oct. 31, which will be fitted up and occupied Jan. 1. The change is made to secure larger quarters, and the firm will increase their output 25 per cent.

Within a few days the handsome tract of land in the eastern part of Waterbury which Mrs. D. B. Hamilton is to give to the city as a memorial park in honor of her late husband, David B. Hamilton, president of Rogers & Bro., will formally come into the possession of the municipality. The property will probably first be transferred to Mrs. Hamilton, who in turn will execute a deed of gift to the city.

George H. Wilcox, vice-president of the International Silver Co., and George M. Curtis, assistant treasurer of the same concern, left Mer-

**One of Our Latest Productions.**

MANY OTHERS YOU WILL FIND ILLUSTRATED IN OUR

**NEW FALL CATALOGUE,**

WHICH SHOULD BE IN YOUR POSSESSION.

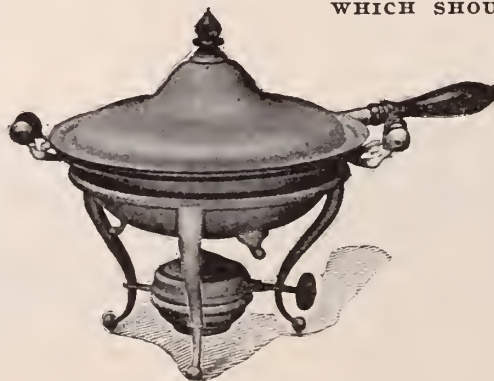

Patented Sept. 12, 1899.

**S. STERNAU & Co.**

.....Manufacturers of.....

Metal Wares in Brass,  
Copper and Silver,

**204 Church St.,  
Corner Thomas St.,  
NEW YORK.**

iden the latter part of last week and both will be away from here for two months or more. Mr. Wilcox, accompanied by his wife, left Friday for a tour through the west to California. Mr. Wilcox's health has become somewhat impaired, owing to hard work during the past two years, and the trip is taken in hopes of fully restoring it. Mr. and Mrs. Curtis and their daughter, Agnes, sailed Saturday on the *Campania* for a two months' European tour.

### Springfield, Mass.

Max Hirsch, for several years with J. W. Nickels, has taken a position with E. E. Penny.

F. C. Smith, 78 Worthington St., is adding new fixtures to his equipment and making other improvements in preparation for holiday trade.

A. L. Campbell has opened a new store at 485 Main St., the location being that formerly occupied by J. F. Whipple, who retired from business a few months ago.

F. E. Ladd is putting a new front in his store on Main St. When finished the store will be one of the most imposing in town. Mr. Marvin, formerly with C. H. Place, St. Albans, Vt., has taken a position with this house.

### The Attleboros.

John D. Wilson, of Boston, called on local business friends last week.

F. I. Gorton's jewelry factory is nearly completed and will be occupied in a few days for business.

The residence of Louis J. Lamb is in quarantine, for Leonard, his youngest son, has been very ill with diphtheria.

Some of the machinery in the C. T. Guild factory is being removed and larger and more modern apparatus of the same kind substituted.

James E. Blake, of the James E. Blake Co., treated his female employes last week to tickets to a very fine stereopticon lecture in the Bates opera house.

The local press announce the approaching wedding of Ernest J. Qvarnstrom, partner in Carter, Qvarnstrom & Remington. He will wed Miss Mabel F. Shaw within a few days.

Albert G. F. Heise, a local silversmith, is in the toils of the law. He was arrested last week and taken to New Bedford, where he was found guilty of failure to support his wife and minor child.

This week will see some steps taken by R. F. Simmons & Co., and probably by the H. M. Williams Co., in regard to the

suits for infringement of patented processes of making seamless wire brought against them in August by the Burdon Wire & Supply Co., of Providence.

Work was begun last week on the erection of the new refinery on Union St., which will be an Attleboro branch of the Providence one run by George M. Baker. The land was purchased of Everett S. Horton, of the Horton, Angell Co., and the transfer has been just filed. The building will be 40x80 feet, one story, of brick, and will be erected within six weeks, provided the weather favors.

Three jewelers of this section are talking of southern pleasure trips very soon. Charles M. Robbins looks forward to a trip to Florida and Havana, taking his sample cases along with him. Mark E. Rowe is quoted as intending to visit the national capital and then go further south for several weeks. J. Perry Carpenter, of Ford & Carpenter, Providence, was planning to accompany Mr. Robbins, but has changed his plan and will go on a fruit steamer for the voyage to Jamaica.

The new building of S. O. Bigney & Co., on Wednesday, Nov. 1, was exactly in the state of partial completion promised by that date, the shafting in, the power connected, and on that morning the shafts

**WHO KILLED COCK ROBIN?**

THE SPARROW CLAIMS THAT HE DID,  
PERHAPS THE SPARROW TOLD THE TRUTH.  
WE HAVE A CLAIM TO MAKE THAT IS  
BASED ON TRUTH BEYOND A  
PERADVENTURE.  
AND THIS IS THE CLAIM.

**AMERICAN WATCHES.**

**ELGINS WALTHAMS HOWARDS.**

CERTAINLY  
THE MOST COMPLETE LINE IN AMERICA.

**C. G. ALFORD & CO.**

195 BOWWAY NEW YORK.

spun merrily round, and Mr. Bigney had kept his word. In the height of the busiest season no firm from among those who have engaged quarters could spare time for moving in, and it will be probably into January before the power is used for running those plants. But obstacles have been overcome and the big building project has advanced to a point where Mr. Bigney sees the light ahead.

The movement inaugurated a fortnight ago by Homer M. Daggett, Jr., of the Daggett Jewelry Co., looking to a release of the jewelry manufacturers of the Attleboros, Chartley and Plainville, from the provisions of the annoying Massachusetts factory laws, is for the time quiet. The petition to Rufus R. Wade, head of the State police, for such release, while important, was but the opening gun of a campaign, and the manufacturers associated with Mr. Daggett in his work declare that another move in furtherance of the project is under way. The keenest interest in the matter is felt by every jeweler, with less than five exceptions, in the four towns, for all feel that the laws interfere with the conduct of their business in a way perhaps proper in cotton milling towns, but out of place in a jewelry community.

#### Outlook for Prices of Diamonds.

[Brooklyn Daily Eagle, Nov. 2.]

**I**F the war in the Transvaal and in all South Africa assumes any larger proportions and continues for any great length of time there is no estimating the price to which the precious stones will fly. If the war lasts two years diamonds will go up beyond the reach of all except the very richest.

"The price of diamonds will increase 1,000 per cent, if necessary, to make the mines pay a certain dividend," said Ludwig Nissen, a large wholesale diamond dealer and importer of New York, when asked about the effects of the Transvaal war as manifested here. "The entire output of diamonds is controlled by one close syndicate," continued Mr. Nissen. "The only place in the world where diamonds are mined is Kimberley, now besieged by the Boers. Some few little stones may be picked up in drifts or found occasionally in other parts of the world, but Kimberley is the only place in the world where diamonds are produced. The syndicate that owns the mines there sends the whole output to London in a rough form and another close syndicate markets the diamonds. The syndicate owners demand that the mines pay a certain dividend on investment. If the output does not permit of this dividend being paid at ordinary prices of the stones the prices are raised to enable the owners to realize the demanded dividend."

#### Death of Moses Bruhl.

Moses Bruhl, a former prominent importer of precious stones, whose critical illness was spoken of in *THE CIRCULAR* last week, died at his home, 21 W. 38th St., New York, early Wednesday morning.

Mr. Bruhl, who had been formerly a partner in the old firm of D. & M. Bruhl,



THE LATE MOSES BRUHL.

had passed 35 years in the precious stone industry in this country and retired therefrom in 1889. He was born in Worms, Germany, 64 years ago, and in 1854, when a lad of 18 years, came to America. His eldest brother, David Bruhl, had come to this country in 1848, founded a precious stone importing business, and had been joined by his other brother, Samuel Bruhl. With this house, then known as David Bruhl, Moses Bruhl became employed in a very small capacity, and gradually rose until he was admitted as a member of the firm within a few years after starting. The business increased, and David Bruhl went to Paris to look after the interests there about 1860, and has remained in that city since that time. Samuel Bruhl died in 1874, and Moses Bruhl then became head of the New York house, looking after the interests here. During the time he had charge of the firm a branch was started in Providence, R. I., and another in Yokohama, Japan, and these last two came under the direct supervision of the deceased. Prior to this the brothers had been joined by the youngest of the family, Simon Bruhl, but he became blind in 1877, and retired and went back to Europe. Moses Bruhl and his brother, David, retired from the business Jan. 1, 1889, and the firm,

then known as D. & M. Bruhl, were succeeded by one known as Bruhl Bros. & Co., which consisted of David Bruhl's sons, Paul and Henri, Solomon Bass, Samuel Sondheim and L. Lilienthal.

The deceased was twice married, first to Miss Betty Bass, and the second time, on May 1, 1877, to Miss Bijur. His wife and two daughters survive him.

During his career in the jewelry trade Mr. Bruhl was known as a thoroughly progressive man, and was a wide reader and exceptionally well informed on general topics. After his retirement he devoted much of his time to study, especially on the subjects of religious criticism. The deceased was noted for his many charities, and was a subscriber to almost all the Hebrew benevolent organizations. He endowed a fund in honor of his first wife, known as the "Betty Bass Prize Fund" in the Hebrew Benevolent Orphan Asylum. Eight years ago Mr. Bruhl was stricken with heart disease, but did not suffer from this ailment acutely until within the last eight months. Since that time he grew gradually worse, and his death, when it came, was not unexpected. He had few business interests outside of the precious stone trade, but was a director in the Celluloid Co. and was at one time interested in the *Forum* magazine. Funeral services were held from his late residence at 9 o'clock Friday morning, and were largely attended. Dr. Silverman, of the Temple Emanu El, officiated and Dr. Felix Adler also made an address. The remains were interred in Cypress Hills Cemetery.

#### Sudden Death of J. Harry Wright.

LONG BRANCH, N. J., Nov. 2.—J. Harry Wright, jeweler, 47 years of age, dropped dead yesterday afternoon. He had just stepped from the kitchen, when he was stricken with heart disease. He died before medical aid could be summoned. Mr. Wright leaves a widow and five children.

M. R. Hale and C. L. Fogelburg, who conducted a silver plating business at 13 Broad St., Utica, N. Y., up to the time it was damaged by fire a few weeks ago, have left town, and also a few creditors. They received in insurance \$400, but claimed \$1,200 loss.

While standing on the L. & N. platform, Russellville, Ky., Oct. 30, where he had gone to meet his wife, Ben Settle sustained a stroke of paralysis. He has no use of his left arm and very little use of his left leg and his speech is also affected. Though in a serious condition, the physicians believe that he may recover.

## The Mercantile National Bank

OF THE CITY OF NEW YORK,

BROADWAY AND DEY STREET,

Solicits Accounts from the Jewelry Trade.

**Providence.**

W. C. Fisher, hub cutter and designer, has removed to 220 Eddy St.

Spatcher & Parker, tool makers and machinists, have opened a shop at 187 Eddy St.

S. Seligman and Max Weber, representing Pichel & Weber, New York, were in town last week.

W. L. Brewer, of this city, representing Doran, Bagnall & Co., North Attleboro, has been ill in New York for the past few days.

The will of Celeste L. Hutchins, late wife of Sterns Hutchins, has been admitted to probate. Sterns Hutchins was named executor, bonds \$500, without surety, to pay debts and legacies.

The firm of S. W. Bassett & Co., consisting of S. W. Bassett and W. T. Gonsolve, have recently dissolved, and Mr. Bassett will continue the business alone under the same firm style.

It is understood that the Howard Button Co., now located at 178 Eddy St., will soon remove to the Manufacturers' building. They will occupy the space made vacant by the removal of the Providence Optical Co.

In the Sixth District Court, Civil Division, on Thursday, the case of the Hunt Jewelry Co. vs. John E. Henderson, for alleged trover and conversion of a watch, was decided in favor of the defendant for costs by non-suit of the plaintiffs.

Lenzen & Reuckert have taken the quarters in the Metcalf building recently vacated by S. W. Bassett & Co. The latter firm have moved up stairs. The result of this change by Lenzen & Reuckert is a material increase in the floor area occupied by the firm.

Before Justice Wilbur, in the Common Pleas Division of the Supreme Court, Frederick J. Winder was, Nov. 2, found guilty of stealing silver wire from the Gorham Mfg. Co. Winder, who was a former employe of the Gorham works, was indicted by the Grand Jury and came up before Judge Wilbur and a jury for trial to-day. The verdict was "guilty," but sentence was deferred and a stay of proceedings was granted until Jan. 1, 1900.

Gardiner B. Merrill, who for 20 years had conducted an engraving business at 3 Weybosset St., fell from a chair at his home Nov. 3 and received injuries which resulted in his death half an hour afterward. As he fell from the chair his head struck the corner of a cupboard, causing concussion of the brain, from which he did not rally. The deceased was 65 years of age and a native of Lowell. He leaves a wife, one son, who is now in New Hampshire, and two brothers.

Frederick Stedman, the young man who is charged with having deprived E. L. Logee of a watch and other valuables, amounting in value to about \$1,000, was arraigned in the Common Pleas Division of the Supreme Court early last week to answer to the indictment found against him by the Grand Jury. He pleaded *nolo contendere*, and in default of \$5,000 bail was committed, sentence being deferred. Stedman was arraigned a week previously, but at that time pleaded not guilty.

A fire which did but slight damage but which caused a stampede among the women employes of Watkins & Co.'s jewelry establishment, broke out in the Greene building, in the rear of the Enterprise building, at about 3 o'clock p. m. Nov. 2. The fire started in the shop of Everett & Barrows, directly underneath the shop of Watkins & Co. A small quantity of russet paste was ignited by a lamp and the flames quickly

communicated to a pile of packing material. There was considerably more smoke than blaze, the former making its way up into the shop of Watkins & Co., throwing the girls employed there into a panic. They stampeded for a place of safety, but fortunately no one was injured. The automatic sprinklers began to work and the flood from these extinguished the flames before the firemen arrived.

A A

**AROUND THE CIRCLE**

our travelers are taking orders every day during eleven months of the year, but they cannot possibly call upon all of our customers when they are in need. Some three thousand jewelers have not yet opened an account with us. We mean to interest five hundred new customers around the circle this season. Do you want honest goods, fair dealing, prompt filling of orders? If you do, "get into the band wagon." Consult our catalogues, circulars or salesmen. We have no old style goods. Everything new and salable. Our firm is still very young (only 10 years established). We sell a thousand and one knick-knacks in Sterling Silver and Solid Gold.

Have you our latest catalogue?  
BUY OF THE MAKERS.

**AVERBECK & AVERBECK,**  
19 MAIDEN LANE,  
NEW YORK.

A A

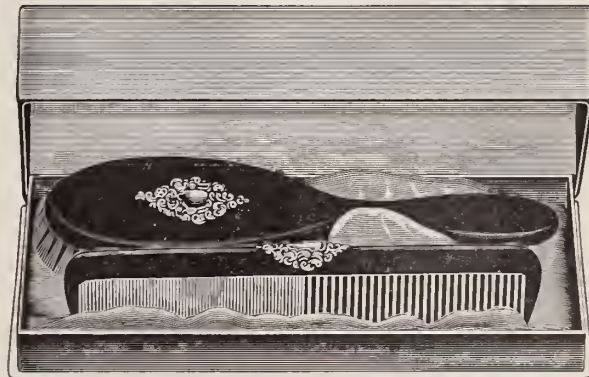

No. 913. Illustration 1-3 size.

**Genuine Ebony (solid back) Brush and Comb, Sterling Silver Mounted, in box, complete, \$15.00 PER DOZEN.**

Our Lines make Easy Selling. Your stock incomplete without them.

SEND FOR ILLUSTRATED CATALOGUE AND PRICE-LISTS.

**S. C. POWELL,** MANUFACTURER, SILVER NOVELTIES, GLASS GOODS, ETC.,  
51 & 53 MAIDEN LANE, NEW YORK.

# TO RETAIL JEWELERS, WARNING

## Keep Tabs on the Tags and Swivels.

When you buy Blackinton Chains the stamps on swivels tell the story.

EACH TAG AND STAMP ON SWIVEL REPRESENTS A DIFFERENT QUALITY

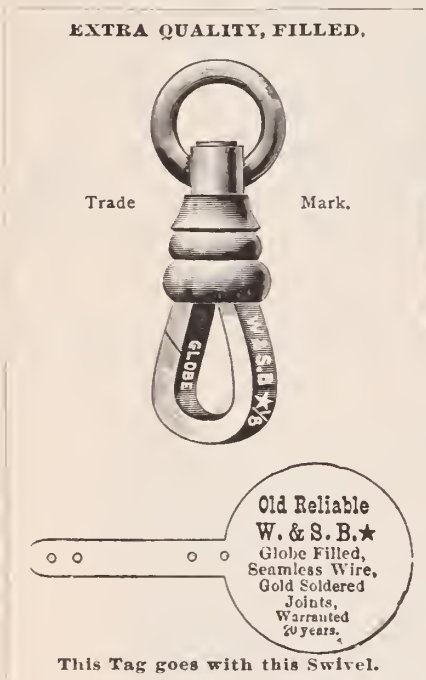

OLD RELIABLE

### W. & S. B. ★ GLOBE FILLED

ARE EXTRA QUALITY AND WARRANTED TO ASSAY  $\frac{1}{8}$  GOLD.

OUR REGULAR

### OLD RELIABLE W. & S. B. ★

ARE  $\frac{1}{10}$  PLATE AND SUCH AS WE HAVE MADE FOR 30 YEARS.

IF YOUR SWIVELS BEAR EITHER OF THE ABOVE TWO STAMPS YOU ARE SURE OF GETTING CHAINS THAT EXCEL IN

### QUALITY, DESIGN AND FINISH,

THE GREATEST OF VIRTUES THAT COMBINE TO MAKE A LINE OF GOODS

### RELIABLE AND SALABLE.

EVERY JOBBER CARRIES THESE CHAINS. INSIST ON SEEING THEM; A CAREFUL EXAMINATION WILL PROVE THE ABOVE.

Fa





EMPIRE STATE EXPRESS RUNNING 60 MILES AN HOUR. UP TO DATE, LIKE BLACKINTON'S CHAINS.

QUALITY.



Mark.

l Bellable.  
W. & S. B. ★  
Seamless Wire.

s with this Swivel.

 **STAR AND CRESCENT**

so stamped on Tag and on Swivel.

THIS IS OUR **2d QUALITY.**

**CAUTION**

Retailers when buying should be most careful to see that chains so stamped are not sold as either the old reliable W. & S. B. ★ GLOBE FILLED or the old reliable W. & S. B. ★. THIS IS BEING DONE AND HAS BEEN DONE EXTENSIVELY.

SECOND QUALITY.



Trade

Mark.

 **WARRANTED**  
14 Kt. Plate,  
Seamless Wire.

This Tag goes with this Swivel.

**W. & S. BLACKINTON.**

ry, Providence, R. I.

New York, 14 Maiden Lane.

# A Short Talk With Jewelers

You are no doubt aware that a number of Manufacturers of Silver Ware are catering largely to the Dry Goods and Department Stores, and that the latter are distributing their Catalogues broadcast throughout the country, and that many of them enter the homes of your customers. If you have these goods represented in your stock it cheapens and lowers them in the estimation of your customers, as a person who is desirous of making a wedding anniversary or birthday gift of an article of Silver Ware, and by so doing expressing their regard for the recipient by bestowing an article of value, would feel reluctant to present an article for such occasion identical with those illustrated in a Dry Goods Circular. Therefore, is it not for your interests to confine your purchases to those Manufacturers who place their goods only through the legitimate Jewelry trade, and who refuse to supply them to the Dry Goods and Department Stores?

It is not enough that a manufacturer does not sell a Dry Goods house in YOUR City, for these Catalogues go to every large city and small town, and your competition is just as direct with the Dry Goods Catalogue, as though the Manufacturer supplied them in your own city. The GORHAM MFG. COMPANY have for years pursued the policy of confining the sales of their wares to the legitimate Jewelry trade, and their customers are absolutely free from the charge of carrying Dry Goods silver ware in their stocks, and in addition to this, the articles are more exclusive and refined, the finish and workmanship better, and the prices no higher.



## Gorham Mfg. Co.,

...SILVERSMITHS...

Broadway and  
19th Street,  New York.

BRANCHES:

NEW YORK:  
21 & 23 Maiden Lane.

CHICAGO:  
131-137 Wabash Avenue.

SAN FRANCISCO:  
118-120 Sutter Street.

WORKS: PROVIDENCE, R. I., AND NEW YORK CITY.

# The Jewelers' Circular

AND  
HOROLOGICAL REVIEW.

PUBLISHED EVERY WEDNESDAY BY  
**THE JEWELERS' CIRCULAR PUB'G CO.,**  
CORBIN BUILDING, 11 JOHN ST., COR. BROADWAY,  
NEW YORK.

TELEPHONE: CABLE ADDRESS:  
1148 CORTLANDT. JEWELAR, NEW YORK.

A JOURNAL DEVOTED TO THE INTERESTS OF JEWELERS,  
WATCHMAKERS, SILVERSMITHS, ELECTRO-PLATE MANU-  
FACTURERS, AND ALL ENGAGED IN KINDRED BRANCHES OF  
INDUSTRY.

Member of the American Trade Press Association.

Our editorial columns will contain our own opinions only, and we shall present in other columns only what we consider of interest or value to our readers. Advertising matter will not be printed as news.

Advertising rates in THE CIRCULAR are lower, considering the number of tradesmen reached by its large circulation, than in any other jewelry journal.

Notices of changes in standing advertisements must be received one week in advance; new matter can be received up to Monday.

## INFORMATION FOR SUBSCRIBERS.

### Terms of Subscription, Postage Prepaid.

	PER ANNUM.
United States and Canada, - - -	\$2.00
Foreign Countries in Postal Union, - - -	4.00
Single Copies, - - - - -	.10

New Subscribers can commence at any time.

Payments for THE CIRCULAR, when sent by mail, should be made in a Post-Office Money Order, Bank Check or Draft, or an Express Money Order or Registered Letter. All postmasters are required to register letters whenever requested to do so.

Pay money only to authorized collectors having proper credentials.

**Returning Copies.** Returning your paper will not enable us to discontinue it, as we cannot find your name on our books unless your address is given.

**Changing Address.** In changing address always give the old as well as the new one. Your name cannot be found on our books unless this is done.

**Discontinuances.** We will continue to send papers until there is a specific order to stop, in connection with which all arrearages must be paid; but such an order can be given at any time, to take effect at or after the expiration of the subscription. All such orders will be promptly acknowledged by mail.

**Liability.** The courts have decided that all subscribers to journals are responsible until arrearages are paid in full and an order to discontinue has been received by the publisher.

### THE JEWELERS' CIRCULAR IN EUROPE.

Among the places in Europe where THE JEWELERS' CIRCULAR is on file are the following:

**LONDON**—First Ave. Hotel, Holborn, E. C.; Holborn Viaduct Hotel, Royal Hotel.

**PARIS**—Hotel de L'Athene, Rue Scribe.

**LEIPZIG**—Handels-Zeitung, fur die gesamte Uhren-Industrie.

**BERLIN**—Deutsche Uhrmacher Zeitung, Jager-Strasse, 73.

**GENEVA**—Journal Suisse D'Horlogerie.

**AMSTERDAM**—Continental Club, Hotel Amstel.

**ANTWERP**—Diamond Club, Rue de Pelican.

Vol. XXXIX. Nov. 8, 1899. No. 15.

Every line of reading matter in THE JEWELERS' CIRCULAR, with the exception of the few brief extracts from exchanges, always properly credited, is written exclusively for this journal. Each issue of THE JEWELERS' CIRCULAR is copyrighted. Permission to quote is extended to other publications provided such quotations are properly credited.

If you need diamonds for Christmas you will be wise if you hurry and buy them now. For the war in Africa is going to make diamonds high priced, if not scarce.—Editorial in *Brooklyn Daily Eagle*, Nov. 5.

THIS is in a few words the true analysis of the diamond situation, and jewelers should impress these facts upon their customers and prospective customers as deeply as possible, by reiterating them in their advertisements and in their verbal negotiations.

### The New Jeweler with Little Capital.

THE recent failure in Canada of half a dozen or more small jewelers has caused considerable comment in the commercial journals of the Dominion on the lot of the jeweler who attempts to do business on a very little capital. "His hopes for pulling out of the narrow groove into which circumstances placed him," says the *Montreal Journal of Commerce*, "cannot be said to be dependent on trade conditions. Pick up the average daily paper and in its advertising columns are apt to be found stirring announcements of the purchase, at a fraction of its cost, of the entire stock of some retail jeweler who was forced to the wall. This impetus doubtless assists, for the time, the dealer who was in a position to be able to take advantage of a chance for bargains. The average jeweler seldom moves about and is one of the most trusted men in business. He acquires this enviable reputation by earning it from years of correct representation in the sale of his goods. Because they admit of more deception there is a corresponding amount of trust allotted the dealer whose goods prove the faith reposed in them, and the guarantee that accompanied their sale. This confidence is invaluable to the jeweler. When he, at length, advertises a sacrifice sale, he is apt to sweep the town of considerable of its jewelry money and draw much trade from his competitors. How about the dealer who cannot afford to lose trade? He has no other field open by which he can counteract the effects of the inducement which is drawing his customers away. Times may be prosperous or otherwise, but he is not a sharer in their conditions." These conditions exist in the States as well as in the Dominion, and established retailers in limited communities complain that they are fostered by certain wholesale houses who encourage journeymen jewelers and watchmakers to start in business for themselves with little or no capital by stocking up a store and taking a blanket mortgage of the entire establishment. This practice is one of the results of overproduction of merchandise, and is bound to continue; but it is a doubtful source of profit to the wholesaler who follows it, and a distinct menace to the interests of the established retailer.

One of the two men who went into the jewelry store on Fifth Ave., New York, of Arthur Crawford, on Saturday and asked to see some jewelry, grabbed a gold watch case and both ran. They were chased and the thief ran into the arms of a policeman and was caught. He had thrown away the watch case, but it was recovered. The other man escaped.

To insure publication in the following issue, order for space for NEW advertisements must be received not later than Monday noon.

### "Jewelers' Day" at Exposition.

Representative Gathering of Tradesmen from all Parts of the Country in Philadelphia.

PHILADELPHIA, Pa., Nov. 7.—A representative gathering of jewelers and watchmaker from all parts of the east and from points as far west as Chicago was held today at the National Export Exposition, this city. The Exposition management had, at the request of J. Warner Hutchins, president of the Philadelphia Jewelers' Club, named the day "Jewelers' Day," and made special preparations for the entertainment of jewelers from all parts of the country.

The exercises were given under the auspices of this popular organization. At first, when the project originated with Mr. Hutchins and A. G. Lee, a member of the Board of Governors, it was only intended that the evening should be spent by the New York and Philadelphia members of the club in an informal way at the Exposition. But it gradually developed into a celebration of far wider scope, and was actually made one of the most important gatherings of the year.

More than ordinary publicity was given to the project, and applications from jewelers' organizations and representatives of firms all over the country were speedily sent to Mr. Hutchins. Then the members of the Jewelers' Club began to recognize that the day could be made one of serious business import instead of a merely informal junketing trip.

At a meeting of the committee on arrangements last week it was decided to have a fixed programme, and it was announced by the Jewelers' Club that on that day the club house, with its well appointed cafe and reading, lounging, reception and billiard rooms, would be thrown open for the entertaining of out-of-town jewelers who would be afforded every opportunity to see the exposition. The management of the exposition extended to the Jewelers' Club the privilege of using the meeting room on the second floor of the south wing in which to carry out their programme.

### Burglars Invade E. A. Reineman's Store, but Leave the Stock Unmolested.

ALLEGHENY, Pa., Nov. 1.—The jewelry store of Edwin A. Reineman, 913 Federal St., was entered by burglars some time between 6 o'clock last night and 6 o'clock this morning, but nothing was stolen. The burglars gained an entrance through the cellar and up through a trap door in the floor. After breaking open an optical test case they left without attacking the safe.

Mr. Reineman attributes the abandonment of the burglary to the fact that the sign of the Jewelers' Security Alliance was hanging above his safe. This opinion is shared by detectives of the local police force, whom he notified of the robbery.

## BUYERS' INFORMATION BUREAU.

Questions as to the makers of certain lines of goods, where to buy certain lines, where certain kinds of work are done, the owners of certain trade-marks and other matters relating to the buying branch of a jewelry business will be cheerfully answered under this department. The reader cannot ask too many questions.

Mt. PULASKI, Ill., Oct. 27, 1899.

Editor of THE JEWELERS' CIRCULAR:

As a subscriber I would ask you to kindly state in the columns of THE CIRCULAR what you consider the best means of cleaning white velvet lined trays. Awaiting any information which you may give, and which would be duly appreciated. I am Respectfully,

W. W. MAYER.

ANSWER:—We understand that white velvet cannot be cleaned satisfactorily. If the trays have become soiled and unsightly, they should be re-lined. This work is done by S. & A. Borgzinner, 82 Nassau St., New York. In THE CIRCULAR of Oct. 4, page 58, appeared an article on the "Regeneration of Velvet," which can be employed to the best advantage, but we doubt whether in the case of white velvet the result will be altogether satisfactory.

Woburn, Mass., Oct. 28, 1899.

Editor of THE JEWELERS' CIRCULAR:

Will you kindly inform us where we may obtain something in a Chicago souvenir spoon? Having had a call for same, did not know exactly whom to write to, so take the liberty of writing you for the desired information. Awaiting your early reply, we remain, Very truly yours,

L. E. HANSON & Co.

ANSWER:—A Chicago spoon (Fort Dearborn) was made by R. Wallace & Sons Mfg. Co., Wallingford, Conn. Spaulding & Co., 243 State St., Chicago, also have a Chicago souvenir spoon.

NEW YORK, Oct. 27, 1899.

Editor of THE JEWELERS' CIRCULAR:

Will you please give me the names of a few houses who make cane mountings?

Yours very truly,

S. B. L.

ANSWER:—Follmer, Clogg & Co., 414 Broadway; Lott & Schmitt, 116 Walker St.; J. F. Fradley & Co., 114 E. 14th St.; W. J. Braitsch & Co., Fifth Ave. and 18th St., New York.

WATERVLIET, N. Y., Oct. 27, 1899.

Editor of THE JEWELERS' CIRCULAR:

Will you kindly inform me the best book to learn engraving from? Also the price.

Yours truly,

FRANCIS FONCHIA.

ANSWER:—"Practical Instruction in the Art of Letter Engraving," by Whelpley; Second Edition, \$2. This edition has about 200 pages, nearly double the number of the first edition, which sells for \$1.25.

## Death of Louis Mandelstam.

NEWARK, N. J., Nov. 3.—Louis Mandelstam, aged 36 years, died Nov. 1 of liver complaint at the German Hospital, New York, where he had been taken for treatment Thursday last. Mr. Mandelstam was born in Riga, Russia, and after learning the watch making and jewelry business in London, England, went to Summit, N. J., in 1889 and established the business that bears his name. He was taken ill about two months ago. He leaves a widow.

## Trade-Mark Information.

Note.—The publication of our work, "Trade-Marks of the Jewelry and Kindred Trades," containing over 2,250 marks, all told, the accumulation of various works of reference and the ramifications of our business enable us to trace to their origin nearly all marks that may be found on jewelry, silver ware, art pottery and kindred lines, of both American and foreign make. All questions in regard to trade-marks will be cheerfully answered. We would be pleased to have the trade seek the benefit of our facilities regarding the identity of any marks they cannot trace. We would prefer to receive the article for examination; for if the mark is of foreign origin, the slightest difference between a drawing and the original is of great importance.

No question is too trivial nor too complicated for consideration under this department.

WASHINGTON, D. C., Oct. 21, 1899.

Editor of THE JEWELERS' CIRCULAR:

Please tell me whether your book of trade-marks contains a list of the English Hall Marks. You published such a list in THE JEWELERS' CIRCULAR several years ago. I had a copy of it, but have mislaid it. It was perhaps eight or ten years ago, when you published THE CIRCULAR in monthly form. If you can furnish me with a copy of it I shall be glad to have it. Very truly yours,

THOS A. LADSON.

ANSWER:—"Trade-Marks of the Jewelry and Kindred Trades" does not contain a list of English Hall Marks. There were recently published in THE CIRCULAR the marks of the principal English makers of silver and silver plated wares. The marks correspondent refers to were published in THE CIRCULAR more than a dozen years ago, but no extra copies of the issue are on hand. English Hall Marks may be found in Cripp's work, "Old English Time," also in "Old plate" by J. H. Buck.

BEVERLY, Mass., Nov. 1, 1899.

Editor of THE JEWELERS' CIRCULAR:

Will you be kind enough to inform us who makes scissors with silver handles stamped:

STERLING F. I. R.

We have a pair that were brought in for a new handle and we do not know the maker. Thanking you for past favors, we are, Yours very truly,

JOHN B. HILL & SON.

ANSWER:—The initials are undoubtedly E I R, which form the trade-mark of E. Ira Richards & Co., 68 Nassau St., New York. They make such goods.

London has a new fad, says the New York Herald, and the up-to-date New Yorker who aspires to the tiptop pinnacle of English fashion now carries two watches—one the plain, ungarnished chronometer of the business man, the other an ornamental hybrid, perhaps a combination of calendar and timepiece. This is really only a revival of an ancient custom, as the "modern fop" of 1777 is described as sporting

A lofty cane, a sword with silver hilt,  
A ring, two watches and a snuff box gilt.

When the owner and holder of a past due negotiable note receives payment from the person liable on same, a subsequent transferee will acquire no rights other than the transferrer possessed.

A note specifying no particular place of payment cannot be presented at the maker's former place of business, or at a bank in the town where it is payable.

A note given in settlement of claims of doubtful validity is valid, if the maker had knowledge of all the facts affecting their validity at the time he executed it.

## IF THE BOERS DO THIS

**WAR TO MAKE DIAMONDS, DEAR.**  
Special to The New York Times.  
"The Boers," it is said, to-day, "have threatened to destroy the diamond mines, and there is no telling how long it would take to get them in working shape again. Diamond mines are from 800 to 1,100 feet deep, and can be ruined by the explosion of a bomb. To put them back into a condition so that they can be worked again would require an outlay of from £1,000,000 to £3,000,000, and then it would be a question whether the English investors would care to go to such an expense to relieve their properties. The stock of diamonds will not last more than a year, and should the mines be destroyed the values may double within a year."

what will you pay for diamonds?  
Two rises so far this month.  
Buy what you'll need NOW! We'll send anything you want—loose or mounted—"On Memo."

V. WARING, N.Y.

CROSS & BEGUELIN

Importers and Cutters of Diamonds and Precious Stones

43 Rue de Meslay, PARIS

17 Maiden Lane, NEW YORK

**New York Notes.**

T. G. Hawkes & Co. have entered a judgment for \$101.20 against Geo. F. Phesay.

E. Kirstein's Sons Co. have entered a judgment for \$96.10 against Reuben Shepherd.

Among the Transvaal refugees who arrived in this city Sunday were Sender Tykolzky, a goldsmith, and Max Edelman, a watch maker.

Burglars last week made a bold attempt to rob the jewelry store of Abraham Shulman, 4 Myrtle Ave., Brooklyn, and succeeded in getting a small part of the stock.

Benj. F. Rees, of Zimmern, Rees & Co., diamond importers, and A. V. Lambert, of Lambert Bros., retail jewelers, are on the New York County Grand Jury for November.

Louis Meister, Assemblyman from the 14th district, who is again a candidate, is a practical jeweler by trade. At the time of his nomination, in 1898, he was a journeyman jeweler, working at the bench.

On the application of the Bartens & Rice Co. as judgment creditors, Judge Hascall, of the City Court, Thursday appointed Frank M. Holahan receiver in supplementary proceedings for Angela M. Devlin.

Jacques E., Adolphus E. and Frank E. Karelsen, composing the firm of E. Karelsen & Co., were discharged of all their debts in bankruptcy by Judge Brown, in the U. S. District Court, Wednesday.

A. Eastwick Wood, representative of J. B. & S. M. Knowles Co., silversmiths, will be in New York from Nov. 13 to the 18th, making his headquarters at the Hotel Bartholdi, 23d St. and Broadway. While here Mr. Wood will show the full line of his company's productions. He reports business now as being very good.

A number of conductors on the Long Island R. R. were recently discharged on the ground that they had allowed to ride free or for small fare certain instalment jewelry dealers. It is charged that in lieu of payment for goods purchased from these dealers the conductors allowed the dealers to take part or all of the amount due out in rides.

The Watchmakers' & Jewelers' Benevolent Association No. 1 announce that their 12th annual masquerade and civic ball will be held Sunday night, Dec. 24 (Christmas eve.), at Terrace Garden, 58th St. and Third Ave., New York. Particulars may be obtained from Sidney A. Meren, 165 Myrtle Ave., Brooklyn, who is chairman of the arrangements committee.

The *Mail and Express* Thursday published a column interview with Wm. Cooper,

of Cooper & Forman, 3 Maiden Lane, on the rescue by the Clyde Line SS. *Comanche* of the captain and crew of the *Napoleon Boughton*. Mr. Cooper was a passenger on the *Comanche* and vividly described the sinking of the lost schooner and the manner in which her crew were brought aboard the rescuing steamer.

In the Centre St. Police Court Wednesday Rev. Charles B. Cheshire, a colored preacher from Newark, N. J., was held in \$500 on the charge of obtaining money from Tiffany & Co. by false representations. He had secured from the firm a contribution for the John A. Dix Industrial School at Dinwiddie, Va., representing that the school buildings were up and were to open on Oct. 15. Ground has not yet been broken for the institution.

John Forsyth and William M. Davis, against whom two actions were recently commenced in the United States Supreme Court in this city, Monday filed a demurrer and answer to the suits. One action they demur to on the same grounds as came up in the Waterman fountain pen suits mentioned in another column. The answer to the other suit claims that Waterman's patent on which the suit is brought is void for the want of invention and is antedated by about 75 other patents in the United States and Europe, which are enumerated in the answer.

Geo. H. Howland, of Kleinschmidt, Howland & Co., diamond importers, 189 Broadway, is to be married Nov. 22 to Miss Ida C. Milligan, of Brooklyn. The ceremony will be performed at St. Peter's Episcopal Church, State St. near Bond St., Brooklyn, and will be conducted by the Rev. Lindsay Parker assisted by the Rev. Ferris Tripp. The bride will be given away by her cousin, Louis Kimball, with Cross & Beguelin, and the best man will be Daniel Scofield, of Scofield, Melcher & Scofield. Chas. Donnell and Jas. Williamson will be the ushers.

William P. Wilson, Director-General of the National Export Exposition being held in Philadelphia, has asked the Merchants' Association of New York to arrange for and take charge of a delegation of business men to visit Philadelphia, Monday, Nov. 13, that day having been set apart as New York Day. The Merchants' Association have accepted the invitation and some 75 business men of this city, representing a number of different interests, have already consented to go. Full information concerning all details can be obtained from H. D. Lockwood, at the rooms of the Merchants' Association, who has charge of the arrangements.

# Cut Glass.

BEST STYLES,  
LATEST IDEAS,  
LARGEST STOCK.

**C. DORFLINGER & SONS,**

36 Murray Street  
and 915 Broadway,

NEW YORK.



The Fountain  
of Gift Satisfaction.

**Waterman's  
Ideal  
Fountain  
Pen.**

There's no end to its  
usefulness.

It's a good seller and never fails  
to please. Have a full stock.

'99 styles for gifts are chaste  
and beautiful.

**L. E. Waterman Co.,**

155-157 Broadway, New York.

Largest Manufacturers of  
Fountain Pens in the World.

1851.

1899.

## THE CHATHAM NATIONAL BANK, NEW YORK.

CAPITAL STOCK, - - - \$450,000  
UNDIVIDED PROFITS, - - - 974,518

GEO. M. HARD, President.

H. P. DOREMUS, Cashier.

W. H. STRAWN, Ass't Cashier.

**Last Week's New York Arrivals.**

THE CIRCULAR has perfected arrangements for obtaining the names and hotel addresses of all the latest buyers visiting New York, and each day posts in its office, 11 John St., cor. Broadway, a bulletin which every member of the trade is cordially invited to copy.

W. C. Crosman, Auburn, N. Y., Herald Sq. H.; A. Buerkle, Pittsburgh, Pa., Bartholdi H.; C. Tiffany, South Manchester, Conn., Morton H.; E. R. Hill, (Goddard, Hill & Co.), Pittsburgh, Pa., Astor H.; E. Felsenthal (Felsenthal Bros. & Co.), Chicago, Holland H.; W. L. McDougall, Pittston, Pa., Union Sq. H.; A. Paul, Boston, Mass., Marlborough H.; C. F. Rudolph, Wilmington, Del., St. Denis H.; C. J. Wells, Utica, N. Y., St. Cloud H.; I. G. Dillon, Wheeling, W. Va., Marlborough H.; P. H. Linnehan, Birmingham, Ala., Astor H.; B. C. Silver, Montreal, Can., Astor H.; H. G. Mutzer (Kline, Eppihimer & Co.), Reading, Pa., Continental H.; H. J. Rohrbach, Chicago, Ill., Grand Union H.; T. C. Tanke, Buffalo, N. Y., Imperial H.; J. W. Grubb, Wheeling, W. Va., Gilsey H.; C. N. Hancher, Wheeling, W. Va., Marlborough H.

**Philadelphia.**

C. R. Smith & Son have refitted their jewelry store at 18th and Market Sts.

D. V. Brown, wholesale optician, has returned from a trip to Atlantic City.

John M. Scherr, brother of George W. Scherr, died last Tuesday at his home, 161 Brown St.

M. F. Davis, Wilmington, Del., visited the local jobbers and the National Export Exposition last week.

The jewelry store of Charles Kibele, 628 Chestnut St., was closed last week on account of the death of Mr. Kibele's father.

Ralph Binder, of H. Muhr's Sons, has returned from his wedding trip through the south, and is now living in West Philadelphia.

Among the buyers in town last week were Howard Fitzsimmons, West Chester; B. C. Foster, Bristol; F. W. Weiner, Phoenixville; C. E. Finck, Elkton, Md., and George T. Press, Oxford, Pa.

William P. Sackett, the able and genial manager of John Wanamaker's jewelry department, has secured the contract to furnish the prizes for the annual cross-country run of the Schuylkill Navy, to be held on Thanksgiving day.

An account which was filed of the estate of John M. Graham on Friday shows part of the assets to be 100 shares of the capital stock of Queen & Co., Incorporated, wholesale and retail opticians at 95, the value of which is estimated at \$9,500.

An inventory was filed last week of the estate of Charles R. Rittenhouse, a descendant of the famous clockmaker, showing it to be worth \$10,688.54. Among his effects are some valuable high-case Colonial clocks by Rittenhouse and Jacob Godshalk.

State College is infested by a gang of burglars. Last Tuesday night the robbers forced an entrance to Jacob Kusner's jewelry store and stole 10 gold and six silver watches, two gold chains and a pair of shoes. Kusner's loss is several hundred dollars.

Mrs. Morris Paelzer, wife of the well known Market St. jeweler, has been appointed one of the committee of arrangements to provide a programme for the entertainment to be given at the Mercantile Club for the benefit of the college settlement on Nov. 15th.

The jeweled sword recently presented

by the State of New Jersey to Rear-Admiral Sampson is on exhibition in the Chestnut St. show window of Simons, Bro. & Co., where it attracts much attention. This firm, as already reported in THE CIRCULAR, designed and made this sword.

Suit was begun last week in the local courts by William J. O'Donnell and Benjamin G. Booser, trading as O'Donnell & Booser, jewelers, against William A. McClure to recover a diamond ring valued at \$123, which the plaintiffs allege they rented to McClure, and the latter pawned it.

The Numismatic Society of Philadelphia held a memorial meeting last week in honor of Daniel Garrison Brinton, late president of the society, and Carl Edelman, formerly a wealthy jeweler and an illustrious member, who died Sept. 28th. Inman Horner read the obituary notice.

George W. Scherr and Charles H. O'Bryon, members of the bankrupt firm of L. A. Scherr & Co., were examined last week by Theodore Etting, the Master in Bankruptcy. On Monday the back wages of all the employes of the bankrupt firm were paid. The affairs of the firm will be speedily wound up.

It is desirable to correct an item in this column last week referring to Scherr & Co. The facts in the case are these: The firm composed of Geo. W. Scherr and Wm. Weglein, trading as Geo. W. Scherr, Agt., was dissolved Oct. 19, Mr. Scherr retiring and all bills due the partnership being payable to Mr. Weglein. Geo. W. Scherr has accepted a position as salesman with James D. Hughes, and a co-partnership was formed Oct. 27 between Mrs. Geo. W. (Caroline) Scherr and Wm. Weglein under the firm name of Scherr & Co., who are still doing business at 2106 N. 17th St. Mr. Scherr is in no way connected with this firm.

Harry E. Floyd, Glens Falls, N. Y., has had a new mosaic floor laid in his store, has put in two new double deck plate glass show cases, and had the whole interior re-decorated and varnished.

Wm. Carpenter, Salida, Col., has sold his jewelry store to D. J. Kramer. By this arrangement Mr. Kramer will not go to Seattle as he had intended, but will remain permanently in Salida, conducting the business as usual. Mr. Carpenter will return to Santa Barbara, Cal., to spend the Winter.

**TO BLOW EFFECTIVELY IS AN ART**

which we never practice personally; but we have invented a machine which does it for us, called the

"Reichhelm Pressure Blower."

This, with Gas Furnaces and Jewelers' Tools generally, is the stock in trade of

**E. P. REICHHHELM & CO.,**  
23 JOHN STREET, NEW YORK CITY.

**WOOD CUTS.**

*"Engraving direct where type is unnoticed"*

**THE D. B. WHITE**  
Engravers  
ELECTROTYPE  
New York, N.Y.

89 FULTON STREET.  
TELEPHONE 645-JOHN.

**SUBSTANTIAL SOLID GOLD LINKS.**



Roman Finish.

489



Bright Finish.

1147

**Links with Brilliant Diamonds,**  
**\$3.75 per Pair.**



Roman Finish.

4131

**Also another pattern, Bright, \$12.00 per doz.**

**Nos. 489 and 1147, also other patterns, \$15.00 per doz.**

**We make the prettiest line of Links on the market.**

PRICES LESS CASH DISCOUNT.

**Leys Christie & Co.**  
MANUFACTURERS OF

**65 Nassau St., New York.**

**Special Notices.**

**Situations Wanted.**

**WANTED**—Position as salesman; 15 years' general experience; good record; A1 references. Address G. H., care Jewelers' Circular.

**EXPERIENCED MAN** who can superintend and design; understands the manufacturing of jewelry in all its branches; good references. Address "Expert," care Jewelers' Circular.

**PRACTICAL DESIGNER**, with 15 years' experience in all branches of sterling silver ware, desires position; A1 references furnished. Address "Sterling," care Jewelers' Circular.

**SUPERINTENDENT AND DESIGNER** with large experience in all branches of sterling silver ware desires position; best of references. Address "Designer," care of Jewelers' Circular.

**YOUNG MAN**, well connected and acquainted in jewelry business, desires to associate himself with a first-class firm of manufacturing jewelers; gold goods preferred; will furnish some capital and unquestionable references. Address B. L., care Jewelers' Circular.

**AN OPTICIAN**, watchmaker and engraver wants a steady position with a good firm; understands the business thoroughly; young man, single, sober and steady; have tools and trial case; state salary in first letter; A1 references. Address "Optician," care Jewelers' Circular.

**Help Wanted.**

**WANTED**—A fine engraver and watchmaker until Feb. 1, with prospects of permanent position. Hussey, Hyde & Co., Salem, Mass.

**WANTED**—A good watchmaker; situation permanent to right man. Address D. C. Percival & Co., Jewelers' Building, Boston, Mass.

**WANTED**—A first-class engraver who can also do small jewelry repairing. Send sample of work and references to Henry Kohn & Sons, Hartford, Conn.

**WANTED AT ONCE**, a good engraver and jeweler to go to a southern city of 40,000. Address, with references and sample of engraving, "S." care Jewelers' Circular.

**WANTED**—A good honest young man with three or four years' experience at watch and jewelry repairing and wishes to finish his trade under a good all round workman. Address B. J. F., Mahanoy City, Pa.

**WANTED**—A good watchmaker and engraver at once; steady position; \$15 per week; a nice position to right party; send references and sample engraving, etc., in first letter. Address R. L. Keplinger, Franklin, Pa.

**WANTED**—Watchmaker, jeweler and engraver, single man preferred; all around helper, with tools; \$12 per week; send sample of engraving, references and photograph in first letter; give full particulars; this is a steady job for right party; good store, nice town, in New York State; board and room cost \$3.50 to \$4 per week. Address "Jeweler," care Jewelers' Circular.

**Business Opportunities.**

**FOR 30 DAYS** I offer my jewelry business, or fixtures only, at a very low price; I have been established 35 years. Wm. F. Wallace, Westerly, R. I.

**JEWELRY STOCKS BOUGHT**—Retailers wishing to dispose of surplus or entire stock of diamonds, watches and jewelry can find quick, cash, strictly confidential buyer by addressing S. Marx, 22 Lispenard St., New York City.

**For Sale.**

**FOR SALE**—3 8-ft. show cases, \$25 each; 1 5-ft. 6 in. show case, \$18; these cases are 16 in. high, 24 in. wide, black enamel wood, all plate glass, including mirrors; good condition; 1 oak wall case, 25 ft. long, 6 ft. high, 20 in. deep, 30x50 plate glass mirrors, all lined with black felt; double thick glass in lift sash; medium condition; \$50. The Ruddy Jewelry and Optical Co., 145 State St., New London, Conn.

**INDEX TO ADVERTISEMENTS.**

Aikin, Lambert & Co.....	59	Kohn, Alois, & Co.....	50
Aikin, Lambert Jewelry Co.....	59	Kroeber, F., Clock Co.....	56
Alford, C. G., & Co.....	29	Le Boutillier & Co.....	60
American Watch Case Co.....	45	Ledcrer, S. & B., Co.....	60
Arnstein Bros. & Co.....	60	Ledos Mfg. Co.....	45
Atlas Watch Co.....	38	Lelong, L., & Bro.....	60
Averbeck & Averbeck.....	30a	Lewis, Fred W., & Co.....	21
Avery & Brown.....	16	Levy, L. W., & Co.....	43
Ball, Wm. H., & Co.....	58	Leys, Christie & Co.....	34
Bassett Jewelry Co.....	45	Lind, Thomas W.....	4
Becken, A. C.....	27	Lorsch, Albert, & Co.....	60
Bell Watch Case Co.....	19	Mabie, Todd & Bard.....	56
Bene, Lindenberg & Co.....	42	Malliet, C. G., & Co.....	25
Billings, Chester, & Son.....	21	Mathews & Prior.....	41
Blackinton, W. & S.....	30b, 30c	Mauran, John T., Mfg. Co.....	40
Bonner & Co.....	50	Mathey Bros., Mathcz & Co.....	14
Bowden, J. B., & Co.....	20	Mauser Mfg. Co.....	5
Bradley Polytechnic Institute.....	60	Mercantile National Bank.....	30
Bradley & Hubbard Co.....	56	Mount & Woodhull.....	20
Bryant, M. B., & Co.....	58	Myers, S. F., Co.....	58
Carter, Hastings & Howe.....	21	New England Watch Co.....	15
Chatham National Bank.....	33	Noble, F. H., & Co.....	41
Clark & Coombs.....	50	Nissen, Ludwig, & Co.....	23
Cross & Bequelin.....	32	Omega Watches.....	17
Crossman, Charles S., & Co.....	16	Oppenheimer Bros. & Veith.....	20
Crouch & Fitzgerald.....	59	Oskamp, Nolting & Co.....	42
Day, Clark & Co.....	25	Patek, Philippe & Co.....	55
D'Arcy, F. P.....	41	Philadelphia College of Horology.....	41
Deitsch Bros.....	9	Powell, S. C.....	30a
Delaware Ophthalmic College.....	52	Providence Stock Co.....	60
Dorfinger, C., & Sons.....	33	Rauch & Goldsmith.....	42
Dubois Watch Case Co.....	14	Regnell, Bigney & Co.....	44
Dueber-Hampden Co.....	13	Reichhelm, E. P., & Co.....	34
Eaton & Glover.....	50	Reisner, L. C., & Co.....	3
Eisenmann Bros.....	22	Remington Typewriters.....	59
Eliassof Bros. & Co.....	43	Rich, H., & Co.....	60
Esser & Barry.....	50	Rogers, Wm., Mfg. Co.....	49
Fahys, Jos., & Co.....	18	Roy Watch Case Co.....	17
Fairchild & Johnson Co.....	60	Rumpp, C. F., & Sons.....	49
Field & Beattie.....	34	Saunders, John F.....	21
Foster, Theodore W., & Bro. Co.....	2	Schulz & Rudolph.....	55
Fox & Co.....	20	Selwyn Importing and Trading Co.....	50
Frankel's Sons, Jos.....	19	Sherwood, John W., & Co.....	12
Freund, Henry, & Bro.....	43	Simmons, R. F., & Co.....	46
Friedlander, R., L. & M.....	60	Simmons & Payne.....	24
Fuchs, Ferd., & Bros.....	56	Simons, Bro. & Co.....	48
Goldsmith Bros.....	37	Smith, Alfred H., & Co.....	22
Goodnow & Jenks.....	2	Smith, Wm., & Co.....	56
Gorham Mfg. Co.....	7, 30d	Stern Bros. & Co.....	25, 52
Gregory, E. J.....	59	Sternau, S., & Co.....	28
Harris & Harrington.....	60	Strasburger, Byron L., & Co.....	43
Haskell, H. C.....	45	Strasburger's Son, Louis, & Co.....	24
Hayden Mfg. Co.....	28	Street, Geo. O., & Sons.....	25
Hebbard & Bro.....	45	Sussfeld, Lorsch & Co.....	52, 55
Hedges, Wm. S., & Co.....	20	Towle Mfg. Co.....	40
Heimberger & Lind.....	45	Treibs Bros.....	24
Howard Sterling Co.....	10	Trenton Watch Co.....	14
Hraba, Louis W.....	50	Wadsworth, G. F.....	41
Imperial Mfg. Co.....	40	Wadsworth Watch Case Co.....	42
Jacot & Son.....	59	Waite-Thresher Co.....	47
Juergens & Andersen Co.....	39	Wallace, R., & Sons Mfg. Co.....	6
Juergensen, Jules.....	55	Waterman, L. E., Co.....	33
Kahn, L. & M., & Co.....	60	Westphal, W. C. A.....	59
Kahn's Sons, James.....	25	Wheeler, Hayden W., & Co.....	26
Kendrick & Davis.....	49	Whiting, F. M., & Co.....	4
Ketcham & McDougall.....	59	Wittnauer, A.....	11
Knowles, Dr.....	45	Wood, Chas. F., & Co.....	60
Knowles, J. B. & S. M., Co.....	8	Wood & Hughes.....	56
Kohn & Co.....	23	Woods & Chattelier.....	25
		Zurbrugg, T., Co.....	16

**To Let.**

**FRONT OFFICE**, 18x72 (occupied by the E. Howard Watch & Clock Co. for 14 years); also smaller offices and rooms for light manufacturing; rents low. Knapp Building, 41 and 43 Maiden Lane, New York.

**TO RENT** in Silversmiths' Building, CHICAGO.

A fine office on Wabash Avenue front, with north and east light, 20 x 42 feet, adjoining the Gorham Mfg. Co.'s salesroom on the sixth floor. Most desirable location in the city. For terms apply to

**GORHAM MFG. CO.,**

Silversmiths' Building, CHICAGO.

**STOP THIEF!**

On August 3, 1899, James E. Jeunett, left my employ as watchmaker, very suddenly, taking with him ten watches which belonged to customers, and which had been left with me for repairs. His height is about 5 feet 6 inches, his eyes are very dark, his hair is black, and he sometimes wears a mustache. He is addicted to the use of liquor.

Any information that would lead to his arrest would be liberally rewarded by me.

**B. E. ARONS,** 315-317 Fifth Avenue, Pittsburgh, Pa.

**ANY BOOK** pertaining to the Jewelry, Horological, Optical or Kindred Trades can be obtained through The Jewelers' Circular Publishing Co., 11 John St., New York. Send for catalogue. It is free.

THE OLD FASHIONED WESTWARD TAKES ITS WAY

# WESTERN SUPPLEMENT

## OF THE JEWELERS' CIRCULAR

VOL. XXXIX.

NEW YORK, WEDNESDAY, NOVEMBER 8, 1899.

No. 15.

### Chicago Notes.

All communications in reference to the Chicago department of *The Jewelers' Circular*, addressed to Stephen Parlin, 1522 Lill Ave. (Telephone, Lake View 397), Chicago, will receive prompt attention.

#### TRADE CONDITIONS.

Business with jobbing jewelers continues heavy, although retailers report that the October trade was not up to expectations. In a number of individual lines manufacturers cannot keep up with orders, but in a few others they say orders are easing up. Silver houses had a large trade last year and the gain for the present year is, by comparison, small. October showed the largest gain of any month so far this year in silver—about 20 per cent. Tools and materials continue in active demand and orders for optical goods are increasing. Clock manufacturers are getting more orders than they have clocks to fill—a condition that has prevailed for 30 days past, and is likely to continue up to the holidays. Manufacturing jewelers are doing a fine business—about 50 per cent better than last year and almost double that of 1894.

W. E. Reuling was in buying for his new store at Muscatine, Wis.

F. J. Nevin, buyer for the Meyer Jewelry Co., Kansas City, Mo., was a visitor here last week.

I. Speyer, Goldsmith Bros., is on a business trip to Mexico, and will be absent about six weeks.

J. H. Leyson, Butte, Mont., stopped over for a call on the trade on his return trip from the east.

M. Goldsmith was out on the Kankakee marshes a few days last week, and his friends had ducks galore.

Fred Smith, secretary of the Geneva Optical Co., has returned from a visit to the eastern office of the company.

H. W. Allen, of the Rich & Allen Co., is back from the country around Escanaba, Mich., where he reaped a harvest of grouse and quail.

General manager J. M. Cutter, of the Elgin National Watch Co., is expected back this week from a deerstalking trip in northern Wisconsin.

Seth E. Thomas, of the Seth Thomas Clock Co., spent three days recently with Manager Miller, of the Chicago office. He was on his regular annual visit west.

W. J. Buckley, tower clock man for the Seth Thomas Clock Co., has left for Fort Worth, Tex., to arrange for the erection of

a clock in the new Union depot of that city.

While hundreds of citizens were passing a thief stole a wagon load of goods from in front of the store of C. F. Adams & Co., 203 State St., Oct. 28. The value of the contents of the wagon is estimated at \$500. They consisted of clothing, jewelry and silver ware. The wagon had just been loaded, preparatory to being sent out on its daily trip.

The new reverberatory furnace at Goldsmith Bros.' factory is nearing completion, and will form an important addition to their works. On a recent visit the factory was found to be fully employed, including the 30-ton blast furnace. Where all the sweeps and old gold and silver come from is a mystery to the uninitiated, but Goldsmith Bros. account for it by the fact that they make returns on sweeps within three to five days of receipt of shipment.

W. F. Parker & Co., who opened up Sept. 1 in Indianapolis, Ind., professedly as jobbing jewelers, are being inquired after here by Indianapolis parties. According to the inquiries the firm left the city suddenly after two months of bill contracting, leaving, it is said, many unpaid obligations. According to report they rented two rooms in the Majestic building, for which they failed to pay; bought sufficient clothing on credit to keep up appearances; secured office furniture, which has not been settled for, and avoided paying salary to their help. Several parties are now anxious to learn their whereabouts.

The will of the late Theodore Schrader was filed for probate Nov. 3. The testator died Oct. 30. He left an estate valued at \$52,000. Of this \$40,000 was in personal property, including the jewelry business in which he was engaged at State and Madison Sts. at the time of his death. His real estate holdings amounted to \$12,000. All the property was left to the widow, Mrs. Ida Schrader, who was made executrix without bonds. It is directed that she educate the five children of the decedent and provide for them out of the estate. Mr. Schrader lived at 73 Maple St., where his family still reside. The will was drawn Nov. 1, 1891.

Jewelers from out of town who came in to make personal selections were numerous the past week. Among those noted were: M. Meister, for J. C. Klaholt, Springfield, Ill.; N. V. Cole, Michigan City, Ind.; Webb C. Ball, Cleveland, O.; Mr. Lanphear, Wilbur & Lanphear, Galesburg, Ill.;

George F. Beach, Valparaiso, Ind.; J. H. Leyson, Butte, Mont.; E. M. Howes, of Howes Bros., Clinton, Ia.; D. D. Shane, Grand Ledge, Mich.; G. D. Dawson, Memphis, Mo.; H. Goldman, Milwaukee, Wis.; J. H. Leroy, Fairbury, Neb.; W. J. Keating, Fairbury, Neb.; Mr. Purviance, of George Hay Co., Attica, Ind.; W. A. Shaddell, Crown Point, Ind.; R. N. Ruby, Yorkville, Ill.; Mr. Pierce, Sutherland, Ia.; L. T. Olson, Lehigh, Ia.; A. E. Henry, Rockford, Ill.; Mr. Lightfoot, Bolivar, Tenn.; T. B. Shoebotham, Fort Benton, Mont.; A. J. Shelman, Grand Rapids, Mich.; Mr. Reichel, Sturgeon Bay, Mich.; Dell C. Nelson, Marion, Ia.; Mr. Hastings, Winona, Minn.; Mr. Nisbit, Grand Rapids, Minn.; George P. Rose, La Crosse, Wis.; C. W. Scott, Saratoga, Wyo.; Mr. Smith, Racine, Wis.; E. B. Crawford, Algonquin, Ill.; George W. Howe, Laporte, Ind.; L. H. Bauer, Elgin, Ill.; Emil Fink, Elgin, Ill.; A. M. Smythe, Elgin, Ill.; E. P. Crandall, Emmetsburg, Ia.; J. E. Mix, Elkhart, Ind.; Mr. Bird, of L. M. Bird & Son, Aurora, Ill.

The jewelers' league bowling match, recently played by the Juergens & Andersen Co. and the Wendell Mfg. Co. teams, was a walkaway for the J. & A.'s. Three games were rolled, the J. & A.'s taking all three. Krien had a high average, 165, and Lark had high game, with 194. The scores:

JUERGENS & ANDERSEN CO.			
	1st.	2d.	3d.
Lark .....	194	128	147
Younger .....	109	127	124
Schroder .....	124	132	111
Wendt .....	138	126	153
Renick .....	166	140	141
Fredericks .....	123	159	144
Krien .....	170	166	159

Total ..... 1,024 978 978

WENDELL MFG. CO.			
	1st.	2d.	3d.
Becker .....	155	122	105
Swanson .....	118	108	118
Young .....	92	110	105
Engelman .....	110	114	152
Harris .....	110	118	130
Renick .....	123	118	151
Becker .....	93	131	107

Total ..... 806 821 928

The A. H. Reinke team won two out of three they rolled with the Theo. Schrader team. Six teams make up the jewelers' league: Juergens & Andersen Co., Theo. Schrader & Co., Wendell Mfg. Co., A. H. Reinke & Co., Loftis Bros. & Co., and Geiser & Enright. A meeting is to be held to complete the schedule.



# Life Insurance

is a good thing—for others when you die—but the best way to enjoy life is to make money while you are living. The best sort of a

# Business Insurance

is to sell whatever you have to sell at the highest price. We pay the highest price for **SWEEPS** and **OLD GOLD AND SILVER**. How can we do it? Because of our great facilities and because we get every particle of gold and silver out of the material you send us.

As to our reliability we refer you to any Chicago jobber, any Chicago bank, or any one of the upward of 10,000 jewelers who send their shipments to us.

Furthermore, we assume all the risk! All you have to do is to

## Send us your Old Gold and Silver.

We send you our check on receipt of your package and if our valuation is not satisfactory to you we will return your shipment intact and pay all express charges. You're a sure winner.

# GOLDSMITH BROS.,

Sweep Smelters, Refiners and Assayers,

63-65 Washington Street, ✿ Works: 5826 Throop Street, ✿ Chicago.

**Omaha.**

F. W. Hill, of Richards, Hill & Co., Attleboro, Mass., was here last week. J. L. Crandall, of J. L. Crandall & Co., Providence, R. I., called upon the trade last week.

M. D. Franks, formerly with Jeweler Lytle and later with Geo. R. Holmes, St. Paul, Minn., has been engaged by Mawhinny & Holliday, this city, and placed in charge of their watch department.

M. Thompson, Wisner, Neb.; Neile Treische, Louisville, Neb.; D. Kunkle, Osceola, Neb.; E. O. Harvey, Bancroft, Neb.; J. H. Morning, Yutan, Neb.; H. P. Sutton, McCook, Neb., and W. H. Moore, Tekamah, Neb., were among the out of town traders here last week.

Jos. Frenzer, jeweler, was the designer and manufacturer of a beautiful medal which was presented by the Elks to Belsteddt, the band director, during the last week of the Greater America Exposition. It was of 14 karat gold and very heavy. Upon the medal was an elk's head in raised gold, with two full cut diamond eyes. Around the head, in blue enamel, was the motto "Cervus Alces," and above in blue enamel, a dial. The whole was suspended from a heavy bar of chased gold and weighed 35 pennyweights. It was a handsome piece of work.

**Indianapolis.**

David Gribben, of Gray & Gribben, spent last week in Madison, Ind., visiting his family.

H. W. Bacon, Spencer, Ind.; J. E. Marsey, Springville, Ind.; J. W. Hudson, Fortville, Ind.; A. R. Cooper, Mooresville, Ind., and L. J. Myers, Thorntown, Ind., were in the city last week stocking up.

Louis C. Lowes, who had been in ill health for several years, died Oct 30, in this city. Mr. Lowes was formerly in the jewelry business on Massachusetts Ave., but sold out to L. R. Mauzy, on account of ill health. Mr. Lowes was 40 years of age and unmarried.

**Kansas City.**

The show windows of A. Alisky, W. 5th St., were broken last week and a few watches stolen.

The trade in diamonds has been very brisk for the past two weeks, it seeming as if everyone was afraid the prices would go up on account of the British-Boer war.

About \$200 worth of jewelry was stolen from W. T. Easton's store, Manhattan, Kan., last week. Entrance was secured by forcing a rear transom. The thieves were afterwards captured and most of the plunder recovered.

J. R. Mercer has offered a special prize to local amateurs during the bicycle races to be held in Convention Hall this week. The prize is a handsome bicycle cup of special design. It is expected that other jewelers will contribute likewise to the prize list.

The Manufacturers' Association, of Kansas City, at their last meeting, discussed the best way to secure more of the trade with Mexico. The plan now is to exhibit

in Mexico samples of all the different classes of goods made in Kansas City. Already the trade that the Kansas City jewelers have with Mexico is considerable. Edwards & Sloane Jewelry Co. have had several orders for medals and Masonic charms from that country in the past month.

A letter was received a few days ago by Secretary Winsborough, of the Manufacturers' Association, requesting information about Kansas City with reference to its adaptability as a point for the establishment of a factory for the making of sterling silver ware. The writer of the letter says that he has decided it will be to his advantage to move his factory west, and as he has heard much of Kansas City he has it under consideration as a point for location.

**Detroit.**

George Johnston, of the Johnston Optical Co., recently returned from a trip to Chicago.

D. F. Richardson & Co., cut glass and bric-à-brac dealers, 160 Woodward Ave., held their Fall opening last week.

James B. Moore has been appointed local agent for the New Amsterdam Casualty Co., who insure jewelry stores against burglary, etc.

William E. Fellows, a prominent jeweler at Flint, Mich., was married last week to Miss L. Grace Ayres, a sister of ex-Congressman D. D. Aitken.

Fire at Gaylord, Mich., did \$15,000 damage in the business part of the town. W.

## Over 100,000 Now in Use.

# Improved O Size Atlas Movements

EVERY MOVEMENT  
GUARANTEED.



Nickel Damask.  
Price, \$8.00,  
Catalogue List.

New issue now in NICKEL.  
American manufacture.  
Lever Set Hunting.  
The best American Movement ever  
produced for the money.

**SALE UNPRECEDENTED.**

Write your Jobber for Samples.

EVERY MOVEMENT  
GUARANTEED.



Gilt.  
Price, \$7.50,  
Catalogue List.

## ATLAS WATCH COMPANY,

9 MAIDEN LANE, NEW YORK.

103 STATE STREET, CHICAGO, ILL.

# JUERGENS & ANDERSEN CO.,

92 to 98 STATE STREET,

CHICAGO.



IMPORTERS OF....

## Diamonds, Pearls

And Precious Stones.

## Mounted Goods.

We are also showing an extensive line of new designs in **Pendants, Rings and Emblem Goods**, and invite the inspection of the visiting trade.

SPECIAL ORDER WORK IS AN IMPORTANT  
FEATURE OF OUR BUSINESS.

**If you must wait** until the last moment,  
**Don't forget us** If you haven't

**When ordering Link Buttons,  
 Chains, Bracelets, Ebony  
 Goods, Silver Novelties  
 and Toilet Sets.**

We can fill your order the same day  
 it is received,

**And Save You just 1-3 on Good,  
 Honest Quality Goods**

That will wear and give satisfaction.

**IMPERIAL MFG. CO.,**

**Masonic Temple, - - - CHICAGO.**

*Our  
 Imperial  
 Salesman*

**SPECIALTIES  
 THAT SELL QUICK.**

drop us a postal.

**Georgian STERLING  
 SILVER.**

In Complete  
 Table Service—

**French Gray  
 Finish.**



COFFEE SPOON.

**TOWLE** MANUFACTURING CO.,  
 CHICAGO.

NEWBURYPORT, MASS.



**LINKS.**

Just a Word Regarding Our

**Anniversary Line of 10K. Link Buttons.**

**Every Die New this Season, and  
 Every Pattern a Work of Art.**

We guarantee them not to break and will give a  
 new pair in exchange for any pair that  
 does not give satisfaction.

**JOHN T. MAURAN MFG. CO.**

NEW YORK OFFICE,  
 3 MAIDEN LANE.

FACTORY,  
 PROVIDENCE, R. I.

S. Carpenter, jeweler, was among the  
 losers. His stock was insured.

A. H. Berger, jeweler, Bay City, Mich.,  
 was last week compelled to move his  
 stock out in a hurry owing to fire in an  
 adjoining building. His loss was nominal.

The Johnston Optical Co. say that their  
 prescription business is constantly increas-  
 ing, indicating that people do not depend  
 upon glasses sold over the counter to  
 such an extent as was the fashion a few  
 years ago.

**St. Louis.**

Hess & Culbertson removed to their  
 new stand, southeast corner 6th and Locust  
 Sts., on Nov. 1.

Jos. Gibbs, formerly with Brooks Op-  
 tical Co., has started in business at 1306  
 Franklin Ave.

E. Jaccard Jewelry Co. are showing  
 some fine specimens of the silversmith's  
 art in their show windows. They are prizes  
 for the horse show.

Out-of-town customers here last week  
 were: C. L. Glines, Harrisonville, Mo.; E.  
 F. Waite, Corinth, Miss.; L. C. Welch,  
 Ozark, Mo.; John Koetting, Ste. Gene-  
 vieve, Mo.; Wm. Westphal, St. Charles,  
 Mo.

**Pittsburgh.**

Charles Roberts, of E. P. Roberts &  
 Sons, is in New York buying holiday  
 goods.

E. C. Wilson, formerly with E. P.  
 Roberts & Sons, is now with Hardy &  
 Hayes.

H. B. Hayes, of Hardy & Hayes, will  
 leave in a few days for a Christmas buying  
 trip with headquarters at W. L. Sexton &  
 Co.'s office, 41-43 Maiden Lane, New  
 York.

A. E. Siedle, who has a fine store on  
 Frankstown Ave., East End, will open a  
 branch store at 507 Market St. Preparations  
 are well under way for the opening.  
 Mr. Siedle will continue both stores.

Harry Baker was recently sent to jail  
 for swindling G. L. Ruff, Johnstown.  
 Baker was selling soap, and after inducing  
 Mr. Ruff to purchase a cake, was tendered  
 a \$10 bill in payment. Having no change,  
 he left his outfit as security, went for  
 change and failed to return.

It is reported that two leading dry goods  
 merchants and two well known retail jewel-  
 ery firms will open up a superb retail estab-  
 lishment in the Hacke building, corner of  
 Fifth Ave. and Market St. The situation  
 is unrivaled in the business district, and a  
 store as is said to be projected would be a  
 credit to the city. One of the leaders in  
 the enterprise when approached by THE  
 CIRCULAR representative stated that he  
 "had nothing to say."

Out-of-town jewelers in the city last  
 week were: C. C. Marsh, Sistersville, W.  
 Va.; B. E. Brown, St. Mary's, W. Va.;  
 R. A. Noble, Wellsville, O.; P. J. Manson,  
 Jeannette, Pa.; W. G. Spies, Steubenville,  
 O.; F. H. Hayes, Washington, Pa.; L.  
 Schmidt, Braddock, Pa.; W. F. Brehm,  
 Rochester, Pa.; A. Winter, Zelenople,  
 Pa.; John Linnenbrink, Rochester, Pa.;  
 A. C. Shaner, Sharpsville, Pa.; Mrs. G.  
 A. Bibby, Wilkinsburg, Pa.; John Dwyer,  
 New Castle, Pa.; H. H. Weylman, Kittan-  
 ning, Pa.

**Pacific Northwest.**

B. Erb has moved his jewelry store into new quarters in the Miller block, Republic, Wash.

C. F. Easton, Wallace, Idaho, has decided to change his occupation from watchmaker to prospector. He will close out his stock at once.

W. J. Fritz, jeweler, Port Townsend, Wash., has just returned from a trip to Chicago, where he secured a fine line of silver and glass ware.

R. B. Giles is a new arrival in Shelton, Wash. He brought with him a complete stock of jewelry and will locate there for business, having already rented quarters.

F. W. Owens is having a building erected at Loomis, Wash., which, when completed, will be occupied by him as a jewelry store. He is recently from Republic, where he had a jewelry store.

The Linn County court house at Albany, Ore., is to be provided with a tower clock. The clock will be made by the Seth Thomas Clock Co. It is expected to have it in place by Christmas.

U. B. Vogle, who is retiring from the jewelry business at Corvallis, Ore., says that during the eight years he has been located in Corvallis he has sold over 500 Seth Thomas watch movements.

A. M. Henry and family, Neihart, Mont., left a week since for a tour of the east and will then go to California. Mr. Henry will purchase a stock for his jewelry store while in Chicago and will then locate his family in California.

**Minneapolis and St. Paul.**

Edward Olson, Minneapolis, is papering and decorating the interior of his store.

John A. Vlasek, Minneapolis, has started in the jewelry business at 3035 Washington Ave. N.

S. B. Abeles, Minneapolis, has added a manufacturing and jewelry repairing department to his business.

Miss M. E. Sweet, a graduate of the Bradley Polytechnic Institute, Peoria, Ill., has accepted a position with W. H. El-singer & Co., St. Paul, and has charge of the optical department.

Eastern jobbers and manufacturers represented in the Twin Cities the past week were: F. H. Noble & Co., by A. L. Reach; J. M. Fisher & Co., by Mr. Potter; J. C. Cummings & Co., by E. J. Cummings.

**Notes of the Travelers.**

Benj. Westervelt is calling this week on his trade in the northern part of New York State.

H. C. Rowbotham, with C. P. Goldsmith & Co.'s rings and diamond goods, was in Chicago last week.

E. W. Merrill, traveler for the Tiffany Jewelry Co., Boston, has just returned from a trip through western and southern New England, and reports business excellent. He only remained in the Hub long enough to get together a new line of samples and started out on another trip over his territory.

The following traveling men visited the Indianapolis, Ind., jewelers last week: Geo. Goldberg, W. & S. Blackinton; Frank W. Trewin, Keystone Watch Case Co.; John A. Abel, David Kaiser & Co.; A. H. Oakley, for Thornton Bros.; and Walter E. Hayward; C. H. Higbee, Potter & Buffinton; F. H. Carpenter, R. F. Simmons & Co.; E. A. Tyler, Ansonia Clock Co.; Mr. Sommer, Sommer & Mills Co.; A. O. Waterman, Watson & Newell Co. and Pairpoint Mfg. Co.; F. L. Carpenter, Frank M. Whiting & Co.; Thos. H. B. Davis, Middletown Plate Co.; H. H. Callard, A. F. Towle & Son Co.; Sidney H. Joseph, Eliassof Bros. & Co.; W. S. Gilman, Towle Mfg. Co.; F. N. Wilcox, Rogers, Smith & Co.; T. H. Pope, for Frank W. Smith; Mark Franklin, Louis Kaufman & Co.; Walter Strauss, Jacob Strauss & Sons.

The following traveling men have visited Columbus, O., recently: F. N. Wilcox, International Silver Co.; F. L. Baker, Hayden W. Wheeler & Co.; Mr. Crane, Mandeville, Carrow & Crane; George C. Ridgway, Julius King Optical Co.; Thomas Meyer; E. C. Stone, Battin & Co.; Charles Williams, Gorham Mfg. Co.; W. A. Watts, the Wilcox Silver Plate Co.; Walter S. Strauss, Jacob Strauss & Sons; M. Klipper, Hipp. Didisheim & Bro.; Ernest A. Rose, Allsopp Bros.; D. C. Osborn, Maple City Glass Co.; T. E. Bowne, E. Ira Richards & Co.; G. E. Tinker, Wm. B. Durgin Co.; E. H. Pelletreau, Shafer & Douglas; Halsey Montgomery, for James W. Tufts; J. Rothschild, Ingomar Goldsmith & Co.; J. F. Dean, Reed & Barton; William Seckels; R. P. Coughlin, Wm. L. Gilbert Clock Co.; E. C. McCarter, Lebuecher & Co.; J. G. Rich, Middletown Plate Co.; E. N. Perley, Alling & Co.; Walter S. Noon, W. F. Cory & Bro.; A. L. Fuller, Towle Mfg. Co.

**The Waiter's Vernacular.**

E. W. Leeds, jeweler, Terre Haute, Ind., tells this story: A traveler for a jewelry house called at his place the other day and while making a sale he got into a reminiscent mood. "I was at Peru the other day," said the salesman, "and went in that restaurant near the depot. I asked for some eggs on toast. 'Adam and Eve on a raft,' bawled out the waiter to the kitchen in the rear. I thought that was pretty good, but decided to change that order, and I said I guessed I would have them scrambled. I counted on that stumping the fellow, but he promptly called out: 'Shipwreck that order.' Then I asked for coffee, and he yelled: 'A brown wash with that shipwreck.' I didn't ask for anything else. I had enough."

**F. P. D'ARCY,**  
Jewelers' Auctioneer, 3513 Calumet Ave., Chicago.



Makes sales only for established Jewelers in their places of business.

Indorsed by the leading New York and Chicago wholesalers and every retailer that I ever made a sale for.

I GUARANTEE THE SUCCESS OF ANY SALE I CONDUCT.  
Terms Reasonable, Best of References.  
Write for particulars.

**ABSOLUTELY THE BEST.**



Manufactured by F. H. NOBLE & CO.,

103 State St., Chicago.

Sold by all Jobbers.

**G. F. WADSWORTH,**  
Watch Case Manufacturer  
AND REPAIRER.

Everything in the line of Watch Case Repairing. Old English and Swiss Cases changed to take American Stem-wind Movements a specialty.

OLD CASES MADE NEW.  
CHARGES REASONABLE.

Silversmiths' Building, CHICAGO.

**MATHEWS & PRIOR,**

DESIGNERS AND MAKERS OF

**Sterling Silverware**

TO THE LEGITIMATE

**JEWELRY TRADE ONLY,**

245-247 West 28th Street,  
New York City.



**The Philadelphia College of Horology**

We teach thoroughly

Watchmaking, Engraving,  
Jewelry Work and Optics.

Young Men, Don't be Half Jewelers

when we can make a thorough workman of you in a short time. Write for our Prospectus, which will give you full information. Now is the time to make application for a good bench for the first of the year.

F. W. SCHULER, Principal,  
1215 Filbert Street, Philadelphia, Pa.

DON'T FORGET THE JEWELERS' CIRCULAR PUBLISHING CO.'S BOOK LIST when in want of any technical work in the Jewelry or Kindred Trades.

**Cincinnati.**

**TRADE CONDITIONS.**

Business is increasing every day and the jobbers still cry that they are short of goods in nearly every line. One jobber, it is said, has been going around offering extra percentage for movements in certain grades. The movement situation is still a serious one to the jobbers, as they all are now

saying they will lose many watch sales on account of the slowness of the output.

Miss Laura J. Bryan, of the office corps of the O. E. Bell Co., was married last week to a well known business man of Cincinnati.

I. N. Fox returns this week from a trip to the Pacific coast. Bert Fox goes east this week.

O. E. Bell is in Mansfield inspecting the new buildings now being erected there for the Bell Watch Case Co. They are progressing nicely, all the stone work being done.

J. Shambaugh, a well known traveling man, representing this season Joseph Mehmert, is laid up at Detroit, Mich., with pleurisy of the heart, and is in a dangerous condition.

Three watches and chains were stolen from Henry Cowen's jewelry store, Main St., last week. The thieves effected an entrance through the front door. They were frightened away before they could secure anything else. No clue.

Edward L. Beer, Batesville, Ind., last week consigned the entire balance of his stock of gold and silver watches, jewelry, clocks, silver ware and bric-à-brac to Ezekiel & Bernheim, Cincinnati auctioneers, to be sold at auction Monday, Nov. 6.

L. Loeb, of Herman & Loeb, started out last week for a six weeks' trip, going into the far west. C. F. Bene, of Bene, Lindenberg & Co., has returned from an extended trip and reports business everywhere flourishing. He will go south for his regular Winter trip, and will stop at his Georgia plantation for a few days' rest.

Rauch & Goldsmith, of this city, have had an unusually large and prosperous Fall trade, and all the members of the firm have been hustling. Charles Goldsmith is still out, and has been on a long trip through the northwest, renewing old acquaintances. Charles Rauch is home, but will start out again for a holiday trip.

**THE WADSWORTH  
GOLD-FILLED  
CASES.**



Factory and General Office:  
**Newport, Ky.**

New York Office:  
**11 John Street.**

Chicago Office:  
**Columbus Building.**

Send for illustrated catalogue.

Dealers desiring electrotypes for advertising can obtain them free of cost.

**OSKAMP, NOLTING & CO.,  
CINCINNATI, OHIO.**

**Wholesale Jewelers,  
Diamond Importers,  
Optical Manufacturers.**

Send for Holiday line. Largest stock and biggest variety to select from. All the novelties of the season. Headquarters for optical goods.

**BENE, LINDENBERG & CO.,  
CINCINNATI, OHIO.**

**Wholesale Jewelers,  
Importers of Diamonds,  
Headquarters for Watches,  
Imported and Silver Novelties.**

Write for Prices  
and Samples of  
**HOLIDAY GOODS.**

**RAUCH & GOLDSMITH, WHOLESALE  
... JEWELERS,**

19 West Sixth Street,  
CINCINNATI, O.  
Opp. Palace Hotel.

**Columbus, O.**

I. Kleeman has put in a stock of goods and has taken down his pawn sign.

Carl Baron's wife has been seriously ill and is not expected to live. Mr. Baron is the well known watchmaker at F. F. Bonnet's store.

James Bourquin, who has been in the employ of Goodman Bros. for some time, has resigned and will establish himself in the repair and general jewelry business at 35½ N. High St.

Thieves broke into the store of Joseph Freid, Canal Dover, on the morning of Oct. 29 and carried off about \$200 worth of jewelry. They entered by the back door and the night watchman shot at them several times, but failed to bring them down.

Charles Thompson, who is under arrest on the charge of stealing a lot of jewelry and other goods from a store at Canal Winchester, has told all kinds of stories as to how he came in possession of the goods found on him when he was arrested. The police think they have the right man.

Peter Koch, father of P. M. Koch, jeweler, died at his home on Main St. last Thursday evening at 11.30 o'clock, aged 88 years. He was born in Bonn, Germany, Aug. 6, 1811, and came to this country in 1853 and located in Columbus. He spent his life as a merchant tailor and clothing merchant.

**Trans-Atlantic Voyagers.**

**TO EUROPE.**

D. De Sola Mendes, of the Mendes Cutting Works, New York; S. Konijn, Jr., of S. Konijn & Co., New York, and Wm. Hoffman, of Eichberg & Co., New York, sailed last week on the *Kaiser Wilhelm der Grosse*.

Alvin L. Strasburger, of Louis Strasburger's Son & Co., New York, and Hugo G. Veith, of A. & H. Veith, New York, sailed Saturday on the *Campania*.

Adolphe Paroutoud, New York agent of J. Pouyat, Limoges, France, sailed Thursday on *La Touraine*.

**FROM EUROPE.**

N. Kauffmann, New York, accompanied by his wife and family, returned last week on the *Friesland*.

**Syracuse.**

G. M. Rees will open a new store in the Stone Opera House building, Binghamton, on Nov. 15th.

William A. Corbett, the man who presented forged orders to local jewelers some time ago, was arraigned before County Judge Ross last Monday, and pleaded not guilty to two indictments for forgery. A lawyer was assigned to his defense.

One of the most brilliant of the Fall weddings occurred on Thursday evening, Oct. 26th, at the Fourth Presbyterian Church, when Charles Henry Howe, younger son of Henry J. Howe, jeweler, and Miss Mabel Franc Ostrander, also of Syracuse, were united in marriage in the presence of nearly 600 guests.

**Trade Gossip.**

The International Silver Co., Meriden, Conn., are issuing proofs of a pretty picture entitled "Love that Endures." It is an admirable specimen of the designer's art and of the engraver's and printer's crafts. As a window picture it would serve as an interesting attraction.

There are few volumes published for the wholesale jeweler that are of greater aid to him than the "Jobbers' Hand Book," which is familiarly known as "that little red book." Jewelers who have not received the edition for 1899, which, like its predecessors, contains a complete list of manufacturers of jewelry and manufacturers in the kindred trades should obtain one from its publishers, *The Manufacturing Jeweler*, 42 Weybosset St., Providence, R. I.

Leslie E. Soggs, Binghamton, N. Y., has in his store a handsome new oak double deck show case, the whole thing, except the glass, being his own personal manufacture.

W. O. Blaise, the new jeweler at 97 Court St., Binghamton, N. Y., is making many improvements and changes in his store, and has had it entirely redecorated and painted.

George T. Springer who has recently closed out his jewelry business in Westbrook, Me., will for the present continue the undertaking business in which he is interested as a member of the firm of Spear & Springer.



**How ABOUT <sup>DIAMOND AND PEARL</sup> PENDANTS?**

*Our stock of these meets every requirement—patterns and prices of the prosperity-producing kind. Try some of these stock-brighteners on your next order.*

**HENRY FREUND & BRO.,**  
 DIAMONDS, WATCHES and JEWELRY,  
 9, 11 & 13 Maiden Lane, NEW YORK.  
 ELK GOODS A SPECIALTY.



**"GESSOART"  
 DISPLAY FIGURE.**

18 Inches High.

DECORATIONS IN APPROPRIATE COLORS.

This unique, attractive and useful article, used in the show window for special display of all manner of articles; or can be sold as a card receiver.

PRICE, BOXED, \$2.50; NET CASH WITH ORDER.

**L. W. LEVY & CO.,** Novelties and Optical Goods,

194 BROADWAY, NEW YORK.

Successors to Levy, Dreyfus & Co.

**Rubies and Emeralds.**

**BYRON L. STRASBURGER & CO.,**

Watches and Diamonds,

17 MAIDEN LANE,

NEW YORK.



**Eliassof Bros. & Co.,**

IMPORTERS AND JOBBERS OF

**DIAMONDS, WATCHES, JEWELRY,**

9-11-13 Maiden Lane,

Materials, Tools and Optical Goods.

NEW YORK.

ALBANY OFFICE: 62 & 64 STATE STREET.

### Canada Notes.

J. B. Williamson, Montreal, is advertising a removal sale.

J. R. Stephenson has removed from Streetsville to Hepworth, Ont.

Galbraith & Co., Shelburne, Ont., are offering to compromise with their creditors.

C. S. Newman, jeweler, Halifax, N. S., has returned from a pleasant trip to New York.

The jewelry stock of C. L. Bass, Kingston, was considerably damaged by fire on the 31st ult.

Joseph Bargman, jeweler, Madoc, Ont., has given a chattel mortgage to A. F. Wood for \$70.

E. J. McIntyre, Chatham, has completed extensive improvements and alterations in his premises.

Albert J. Grigg, jeweler, Clinton, Ont., has given a renewal chattel mortgage to W. Grigg for \$1,431.

The bankrupt stock of H. M. Lount, Toronto, was to be sold off piecemeal at auction on the 7th inst.

J. J. Zock, jewelry manufacturer, Toronto, has gone on a fortnight's deer hunting expedition in the North Country.

R. A. Dickson & Co., jewelers, Montreal, have obtained judgment against J. Blacklock and B. J. Fauteux for \$253.

Mrs. M. Cochenthaler, wife of M. Cochenthaler, jeweler, Montreal, has left the city on a two weeks' visit to New York.

T. A. Grothe & Fils, wholesale importers and manufacturing jewelers, Montreal, will hold a bailiff's sale of the goods of Theo. Daoust on Nov. 9.

J. W. Vidito, of M. S. Brown & Co., Halifax, N. S., is at present on a trip to Boston, New York and Philadelphia, in search of Christmas novelties for his firm.

The store of S. Superior, jewelry, &c., 577 Craig St., Montreal, was broken into by burglars on the night of Oct. 27, and several watches, rings and jewelry articles were stolen.

L. Herbert Luke, with Ambrose Kent & Sons, Toronto, has left for a trip to Montreal to attend the opening of a new Temple of the Mystic Shrine at Windsor Hall on the 8th inst.

An attempt was made to enter the store

of Dan Beatty, Montreal, last week. The plate glass was cut out of one of the front windows, but the thieves were evidently disturbed, as no entry was made.

The window of the J. E. Ellis Co., Toronto, contains a display of 14 gold watches which have been purchased by the directors of the Toronto Lacrosse Club for presentation to their team of 1899.

George Chillas, Gorham Mfg. Co., New York; Mr. Scheuer, leather goods, New York; C. H. A. Grant, Montreal Watch Case Co., and E. A. Kirby, Dominion Roll Plate Co., Montreal, were in Toronto last week.

Thomas Brady, representing Smith, Patterson & Co. in western Ontario, and Fred Mansfield, representing the same firm in the lower provinces, were in Montreal a few days ago, preparing for their respective journeys.

The following were the October graduates of the Optical Institute of Canada, Toronto: Mrs. W. S. Briggs, Smith's Falls; G. F. Goodwyn, Arnprior; G. S. Wrathall, Newboro; J. A. Patterson, Maplewood; Miss C. Berkinthall and R. Bain, Toronto.

Four men were arrested a few days ago who are supposed to be part of the gang which has committed so many burglaries in Montreal and vicinity recently, including four or five jewelry stores. In their possession were found safe-crackers' tools, nitro-glycerine, dynamite caps, inflammable tubes, fuses and loaded revolvers.

The continued increase in the price of diamonds is not expected by the trade to lead to any reduction in the sales. The importations have latterly been enormous and the demand under the stimulus of good times continues active. P. W. Ellis, Toronto, estimates the importations of diamonds for August at fully \$250,000.

The premises and stock of P. W. Wood, jeweler, Bleury St., Montreal, were damaged by fire and water Oct. 31. The premises of D. J. Laurie, jeweler, successor to Miller & Bremner, are only a few doors away, but fortunately these escaped injury. Mr. Wood is occupying rooms above the store until it is renovated. The stock was insured.

The following were among the Provincial dealers who visited Toronto last week: J. S. Smith, St. Catharines; Thos. Lees, Hamilton; Mr. Binkley, of Klein & Binkley, Hamilton; W. W. Woods, Brampton; F. H. Nettleton, Collingwood; George Hynds, Acton; W. F. McCarty, Lindsay; W. H. Wegenast, Drumbo; W. J. Chambers, Hillsdale.

Montreal contributed over \$7,000 towards a fund for the benefit of the Canadian volunteers for the Transvaal and their families. Among the jewelry fraternity the following contributed: R. Hemsley, D. R. Hemsley, G. F. Hemsley, Henry Birks & Sons, Mrs. Arthur Birks, R. A. Dickson & Co., R. Sharpley & Sons, Mrs. and Mr. J. S. Leo, Masters Maitland and Alan and Miss Dorothy Leo.

Ryrie Bros., Toronto, are now occupying the extension of their premises on Yonge St., which gives them a frontage of 50 feet on that thoroughfare and the largest floor area of any retail jewelry establishment in Toronto. The store is fitted up with projecting wall cases in the latest style, their design being the same as those of the New York warehouse of the Gorham Mfg. Co., and admitting of small show tables between the cases. They have also handsome new counter cases and all the most modern fittings and appliances. They open with a splendid display of high class art goods and bronzes.

The handsome designs for the hat and shoulder ornaments worn by the members of the Canadian contingent sent to the Transvaal were made by P. W. Ellis & Co., Toronto. The badge displays the maple leaf and the royal crown with the word "Canada" underneath. Those supplied the contingent were of bronze. In consequence of the war enthusiasm now prevalent, this design has become very popular and is being extensively reproduced by the firm in the form of belt buckles, hat pins, links, scarf pins, lapel buttons etc., in gold and silver, and finds an extensive market. The binocular field glasses furnished by the city to the Toronto officers of the Canadian contingent were furnished by the J. E. Ellis Co. The same firm are placing a town clock in the City Hall of St. Thomas, Ont.



Exact size with Ferrule, Sterling Silver Mounting.

We call the attention of the trade to our **Ebonoid Manicure** and **Stationery Articles**.

We claim superior workmanship. The finish of our handles excels all other manufacturers', being equal in appearance to real Ebony. **Send for Samples and Prices**; ask your Jobber for them.

Orders filled promptly.

**REGNELL, BIGNEY & CO., Attleboro, Mass.**

Samples can be seen at our New York office, No. 37 Maiden Lane; also at our Chicago office, No. 126 State Street.



**NONE BETTER.**

**THE  SOLDER**

Recommended by Manufacturers and Repairers.

Our Solders are not plated, but the natural color of the stock.  
Gold Solder in 1 dwt. pieces. Silver Solder in 1/4-oz. sheets.  
Sold in bulk or in any thickness or width desired.  
In Low Karat—6, 8, 10, 14 and 20.

**ASK YOUR JOBBER FOR IT.**  
If he does not carry it, write us.

PRICES ON APPLICATION.

MANUFACTURED  
...BY...

**THE LEDOS MFG. CO.,**  
32-34 Pearl St., Newark, N. J., U. S. A.

American  
Watch Case Co.,

**A.W.C.CO**

9-11-13 Maiden Lane,

Gill Building. New York.

**HENRY C. HASKELL,**

11 Maiden Lane, N. Y.,

has a special department for Jewelry repairing of all kinds. Prompt attention. Prices right. Exclusive Design Plates sent dealers upon request.

**MAINE ANNOUNCEMENT.**

**DR. KNOWLES**

will continue giving private instructions in

**Optometry**

during the month of November in Portland, Me.  
For terms and important particulars write to

**R. H. KNOWLES, M. D.,**  
480 CONGRESS STREET,

ROOM 3. PORTLAND, ME.

**THE BASSETT JEWELRY CO.,**

Fine Gold-Filled Chains,  
Locketts and Gold Jewelry,

PROVIDENCE, R. I.

**"By Using Our Goods Your Goods Will Sell."**

**We Always Lead**

With Something New and Artistic for Manufacturing Jewelers.

**OUR FINDINGS SPEAK FOR THEMSELVES**

Call or Send for Samples of

**OUR LATEST**

**And Keep Your Trade Guessing What You Will Show Them Next.**

We are now showing a handsome and complete line of

**MEDALLIONS AND EBONY MOUNTS.**

**HEIMBERGER & LIND,**

158 PINE ST., METCALF BUILDING, PROVIDENCE, R. I.

All kinds of . . .

**Fancy Wood Chests**

FOR TEA SETS AND FLATWARE.

Silk and Brocade Cases for Silverware and Jewelry.  
Canton Flannel Bags and Rolls.

Photo Frames of every description made in velvet and fancy woods.



**Hebbard & Brother,**

860 BROADWAY, - - NEW YORK.

### News Gleanings.

D. V. Bound has opened a jewelry store in Durant, Miss.

J. S. Freeburn & Co. have opened a jewelry store in Atlantic, Ia.

H. W. Schwertz has opened a jewelry store in Siegersville, Pa.

Eli Leeds, Terre Haute, Ind., will remove to a remodeled store.

W. R. Austin, Port Huron, Mich., has removed to another location.

The Palmer Co. have opened an auction jewelry store in Edenboro, Pa.

Frank Fearl, Hutchinson, Kan., has leased larger quarters in that city.

A. G. Hofman will remove this month from Bucyrus, O., to East Liverpool, O.

Roswell Marsh, Des Moines, Ia., is con-

valescent from an attack of typhoid fever.

J. R. Pogue, Sullivan, Ill., has added watches, clocks and jewelry to his drug line.

A. D. Bristol, jeweler, Ellenville, N. Y., has purchased a house on Market St., that town.

A new jewelry store is being fitted up on Washington St., Haverhill, Mass., for Albert Lordon.

Percival Evans, jeweler, Buffalo, N. Y., was married a few days ago to Miss Elizabeth Armitage.

Thomas Tomlinson is arranging to open a jewelry store in Charleroi, Pa. He comes from Gloucester, O.

The jewelry stock of Lovell & Crane, Pittsfield, Ill., was invoiced last week, and the store is now closed.

James E. Field, from Baltimore, Md., has commenced business as a watchmaker and jeweler at 175 Reed St., Milwaukee, Wis.

Dick Wehrle has purchased the interest of the late B. I. Wehrle in their jewelry business in Indiana, Pa.

John Hess, who will open a jewelry store in Fond du Lac, Wis., has returned from a buying trip to Chicago.

Judson S. Newing, jeweler, Binghamton, N. Y., has signed a lease for the store at the corner of Court and Collier Sts.

Chas. E. Tillson, Livermore, Ia., has moved with his family to Carrington, N. Dak. The change is for the benefit of his son, who is afflicted with asthma.

The Dueber-Hampden Co., Canton, O., on Oct. 28 will send the first shipment of watches from Canton to Manila. The goods are made specially for that market.

Ed. Wangnild and Miss Anna Amundson, of Canton, Wis., were united in marriage a few days ago. Mr. Wangnild will engage in the jewelry business in Colorado.

Jeweler H. F. Eyer, Waynesboro, Pa., has been in Baltimore and Philadelphia to purchase a large stock for his opening in the Bierman room, 68 W. Main St., on Nov. 15.

Thieves a few days ago made an attempt to break into Taylor Bros.' jewelry store, Houston, Tex., but were frightened away by some unknown cause. They had broken a pane of glass.

Chief Wandrich, of Danville, Ill., last week arrested the man who robbed J. P. Hill's jewelry store there about a year ago. The man is Henry Ripley, employed in a local blacksmith's shop. Ripley has confessed.

The entire front of the Edwards jewelry store, Pittsfield, Mass., is to be torn out and replaced with a large front window, making the entrance at one side. Tables will be substituted for counters inside and many other improvements will be made.

A case of diphtheria developed at the home of W. J. Frank, jeweler, Akron, O., a few days ago, his daughter Esther, aged 20, being the victim. The place was quarantined, and half a dozen young women who had been recently with Miss Frank were detained there also.

The A. K. Camp Co., Milwaukee, Wis., are about to retire from business. The company several years ago succeeded the Stanley & Camp Co., organized in 1877. Col. W. S. Stanley was formerly a member of the company and the business change was made when he was elected sheriff, about 12 years ago. A. K. Camp organizing a new company. THE CIRCULAR last week mentioned that P. J. Burroughs had been engaged to sell the stock at auction.

The simple country folk living at the head waters of Hughes River, W. Va., have given up their pastoral life and are now pearl fishers. There are three small streams, all highly charged with minerals and unfit for drinking, flowing into Hughes River. They abound with mussels or fresh water oysters that grow to prodigious size. A few months ago Harris Dobson found a pearl in one of these, and since then thousands of mussels have been taken out and examined. Dobson has many pearls and some of them are quite valuable.

**NOV. 8.**

**DEC. 24.**

Less than two months left to do your Christmas buying. Therefore, act promptly and order at once your needs in

**"Old Standard"**

**Simmons Chains**

**(New Patterns, New Ideas)**

**AND**

**Cyrano Chains, Locketts, Seals,  
and Marlowe Bracelets.**

**AT JOBBERS.**

**R. F. SIMMONS & Co.**

**Factory and Main Office: New York Salesroom:**

**Attleboro, Mass.**

**9-13 Maiden Lane.**

L. A. Orr will discontinue his jewelry business in Conde, S. D.

Paul Freeman will remove from Volga, S. D., to Slayton, Minn.

R. C. Hitchler has removed from Nanticoke, Pa., to Danville, Pa.

John Nielsen, of Lorain, O., will open a jewelry store in Vermillion, O.

R. J. Gabriel, Carthage, Mo., will occupy another room in that town.

E. G. Blake, Farmington, Me., has removed to the Greenwood block.

A. Calhoun, Shawnee, Okla., has filed a voluntary petition in bankruptcy.

John E. Bell, Ogdensburg, N. Y., is making radical improvements in his store.

S. Packer will discontinue his jewelry and furnishing goods business in Seattle, Wash.

W. A. Warrington, Corning, Kan., has renewed a chattel mortgage amounting to \$324.

G. A. De Wandelaer will shortly open a jewelry store in the Lazinsky block, Tucson, Ariz.

W. J. Witham & Son have opened a new stock of jewelry and racket goods in Agra, Kan.

The New Acme Plating Co., of Worcester, Mass., are contemplating locating in Pittsfield, Mass.

W. F. Fischer, of W. F. Fischer & Bro., Chattanooga, Tenn., has returned from a buying trip east.

George J. Consigny, of Crandall & Consigny, Emmetsburg, Ia., has given realty mortgages aggregating \$900.

Leslie H. Holbrook, with T. J. Dale, jeweler, Kenosha, Wis., was recently united in marriage to Miss Anna Powell.

B. F. Tinker has given a bill of sale on his interest in the jewelry business of Tinker Brothers, Maquoketa, Ia., to M. A. Tinker for \$1,000.

The Raine Jewelry Co., of Cripple Creek, Col., have been incorporated by J. C. Raine, Laura E. Raine and E. P. Arthur. The capital stock is \$5,000, all paid in.

Early on the morning of Oct. 28 two men attempted to rob the jewelry shop of L. T. Detrich, 705 E. 12th St., Altoona, Pa. They were working on the front door when a patrolman discovered them. The men saw the officer about the same time and ran away, with the policeman in hot pursuit. They succeeded in getting away in the darkness.

### Birmingham, Ala.

F. S. Jobson is erecting two handsome dwelling houses on the Southside.

J. B. Cook, watch maker at Brilliant, will go to Hamilton to open a jewelry store.

L. H. Morris & Son are now doing watch work at Elba. They have a big stock of jewelry and optical goods.

Samuel Pierce, who came here a few weeks ago and opened a business at 406 N. 20th St., will move to a location on the Southside. Mr. Pierce comes from Cincinnati.

At the Street Fair at Tuskalooza, Adj.-General Brandon gave a fine water service to the one who received the largest number of prizes. The set was engraved by Mr. Sahn, of the Alston Jewelry Co.

Many friends mourn with Ed. Herzog in the loss of his young wife by appendicitis. Mrs. Herzog was only 19 years of age and was ill only 48 hours. Mr. Herzog is leading jeweler and head man for Harry Mercer.

The Birmingham Optical Co. have opened for business at 204 N. 20th St., and are now getting their store into shape. The business will be under the control of W. C. Abbott, senior member of W. C. Abbott & Bro., wholesale and retail jewelers.

Miss Josie Gluck came near being burned to death in the jewelry store of E.

Gluck, last Saturday night, and is now in a very serious condition as a result of her wounds. Miss Gluck was standing near the door, when her brother, E. Gluck, proprietor of the store, came running out with a pan of blazing gasoline, which had become ignited in the manufacturing department and could not be extinguished. Miss Gluck jumped to open the door when the whole lot of burning liquid was dashed upon her. The unfortunate young woman ran into the street and inside a drug store near by. Men standing near snatched her clothing off and saved her life, though she was horribly blistered.

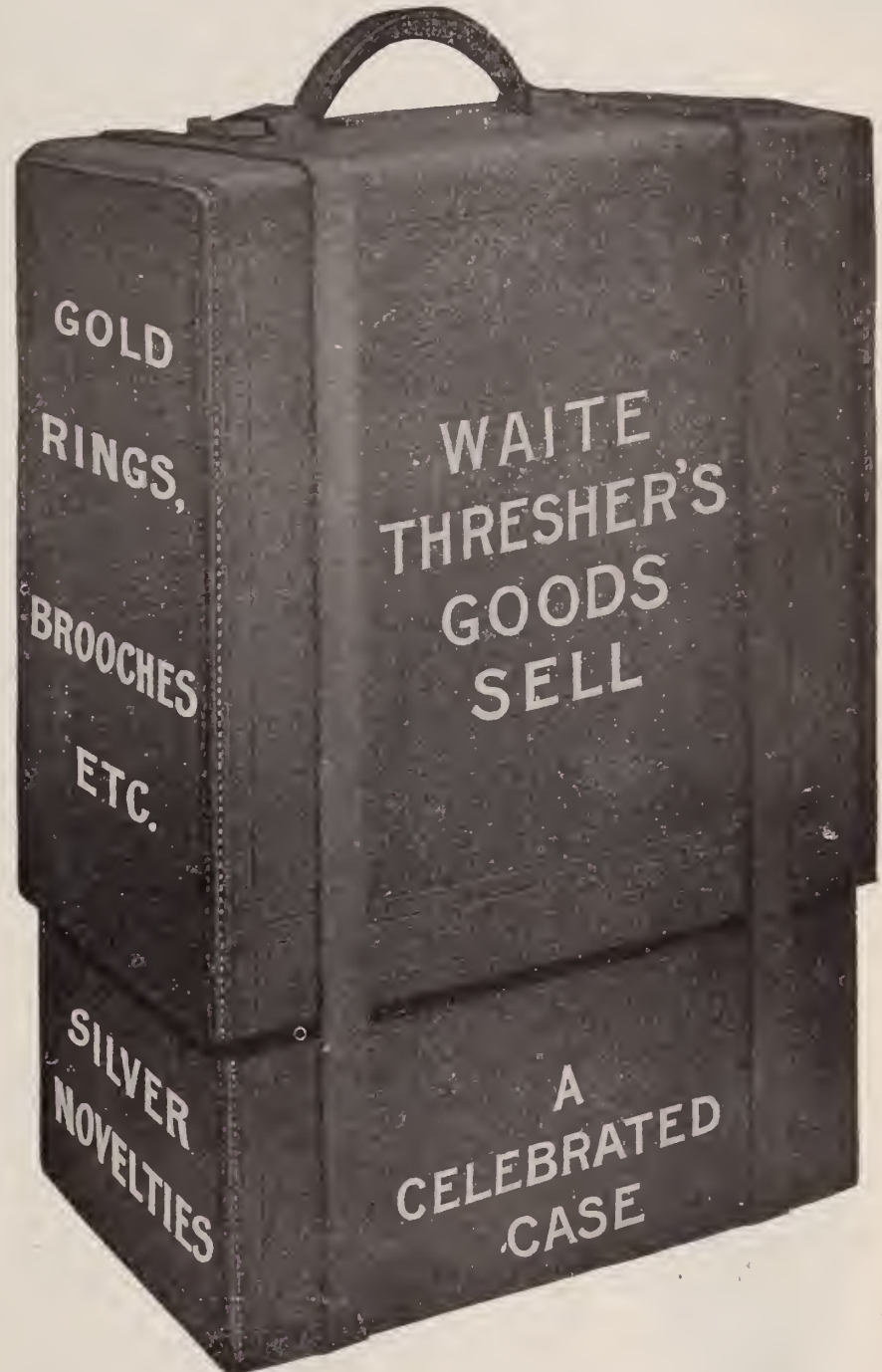

Remember that Articles Purchased from Samples Shown from the Above Celebrated Case are Quick Sellers at Popular Prices.

NEW YORK OFFICE, 11 John Street.

**Our Traveling**

**Representatives**



Traveling representatives may consider these columns open for the publication of any news or items of interest regarding themselves or their conferees.

Among the travelers in Kansas City, Mo., last week were: A. D. Engelsman, Goodfriend Bros.; J. Price, Byron L. Strasburger & Co.; S. T. Shriver, Day, Clark & Co.; S. A. Goldsmith, Adolph Goldsmith & Son; Abel King, I. Emrich & Co.; Frank F. Gibson, for Wm. Kinscheri; F. R. Horton, Carter, Hastings & Howe.

Traveling men in Boston, Mass., the past week included: Harry Lissauer, Ingomar Goldsmith & Co.; E. L. Logee, E. L. Logee & Co.; George B. Osborn, William Smith & Co.; Horace D. Sherrill, Smeck & Sherrill; George Sylvia, Pairpoint Mfg. Co.; T. B. Wilcox, Pairpoint Mfg. Co.; Frank Hadden, John Russell Cutlery Co.; Herman Schwartz, Larter, Elcox & Co.; Mr. Franklin, E. I. Franklin & Co.

The following traveling men were in Omaha, Neb., recently: Fred G. Foster, Unger Bros.; D. Schwab, L. Adler & Son; Richard Merker, Bates Bros. Co.; S. W. Abbey, E. Ira Richards & Co.; J. Price, Byron L. Strasburger & Co.; Chas. De Wolf, Landers, Frary & Clark; F. R. Horton, Carter, Hastings & Howe; W. I. Rice, Louis Hinsberger Cut Glass Co.; W. F. Adams, Simpson, Hall Miller & Co.; Mr. Loeg, L. Adler & Son; H. McConnell, C. G. Alford & Co.; R. Theis, B. H. Davis & Co.; I. Stern, E. & J. Bass; H. Cobb, Daggert & Clap Co.; Geo. H. Kettley,

Abro & Co.; J. H. Montague, with Smith, Hemingway & Co.; Otto Schneider, Hammel, Riglander & Co.

The following traveling salesmen passed through Detroit, Mich., last week: C. C. Hammond, for Rudolph Liebman; J. Alexander, for Frank W. Smith; T. H. B. Davis, Middletown Plate Co.; Walter S. Noon, W. F. Cory & Bro.; J. R. Graham, Merrill Bro. & Co.; Harry Grootage, Chas. T. Bainbridge's Sons; L. V. Benson, LaPierre Mfg. Co.; J. M. Morrow, the American Watch Case Co.; J. R. Goodwin, Carter, Hastings & Howe; Frank J. Keller, the Keller Mfg. Co.; Mr. Smith, S. B. Champlin Co.; H. A. Reichman, Jos. H. Fink & Co.; Jacob Schorsch, I. Emrich & Co.; Fred G. Foster, Unger Bros.; J. D. Friedman, for S. C. Powell; Lewis P. Cook, J. F. Fradley & Co.; H. W. Raymond, Fred C. Steimann & Co.; H. C. Barnum, Shafer & Douglas.

Travelers in Pittsburgh, Pa., last week were: L. Rockwell, Poole Silver Co.; F. R. Krugler, the H. A. Kirby Co.; John A. Davis, International Silver Co.; A. Hashegen, Endemann & Churchill; J. M. Morrow, American Watch Case Co.; Jos. Van Veen, Bradley & Hubbard Mfg. Co.; Fred Clarkson, Albert Lorsch & Co.; C. N. Perley, Alling & Co.; Charles B. Burgess, Frank M. Whiting & Co.; W. L. Mirrielees, Manning, Bowman & Co.; H. L. Sherman, Simpson, Hall, Miller & Co.; C. W. Cary, J. B. & S. M. Knowles Co.; A. N. Dorchester, Chapin & Hollister Co.; Geo. A. Stockder, the J. D. Bergen Co.; D. C. Osborn, Maple City Glass Co.; M. Baum, Rothschild Bros.; Milton S. Rodenberg, Rodenberg & Dunn; Mr. Rounds, Hancock, Becker & Co.; C. L. Bleecker, Wm. S. Hedges & Co.; J. Milleman, Wm. W. Hayden Co.; S. Sichel, Eichberg & Co.; Wm. W. Middlebrook, B. A. Ballou & Co.; Mr. Geigerman, J. Hoare & Co.

Among travelers in St. Louis, Mo., last week were: H. H. Jacobson, Jacobson Bros.; Wm. Matschke, F. & F. Felger; Wm. W. Middlebrook, B. A. Ballou & Co.; Jos. L. Herzog, Louis Kaufman & Co.; H. W. Van Houten, for C. Sydney Smith; De Lancey Stone, Shafer & Douglas; Fred C. Steimann, Fred C. Steimann & Co.; Geo. L. Paine, E. I. Franklin & Co.; Mr. Sidenman, Redlich & Co.; Mr. Boice, White & Major; John A. Abel, David Kaiser & Co.; W. H. Gregory, Stro-

bell & Crane; Geo. W. Wagoner, Wilcox & Everts; J. W. McClannin, Wilcox Silver Plate Co.; W. A. Moore, F. W. Gesswein Co.; A. Marschutz, Spence Optical Mfg. Co.; I. N. Fox, Fox Bros. & Co.; Max Arnstein, Arnstein Bros. & Co.; Sidney Goldsmith, A. Goldsmith & Son; Chas. Boss, American Cuckoo Clock Co.; Jos. Frank, Sussfeld, Lorsch & Co.; Mr. Sommer, Sommer & Mills Co.; Lewis P. Cook, J. F. Fradley & Co.; Frank S. Goff, Bennett & Bradford, W. Wigham, H. D. Merritt & Co.

Traveling representatives calling on Syracuse, N. Y., jewelers the past two weeks included: J. D. Friedman, for S. C. Powell; J. C. Cook, Bergstein & Son; D. Zimmern, Zimmern, Rees & Co.; Cyrus Price, for S. Lindenborn; J. Goldberg; Samuel E. Coggins, Towle Mfg. Co.; R. T. Supple, Wm. B. Durgin Co.; Alva J. Lasher, Wilcox & Everts; James G. Magee, C. F. Rump & Sons; H. B. Richardson, G. A. Dean & Co.; S. Glenn Walmsley, for Hermann Baum; J. W. McClannin, Wilcox Silver Plate Co.; A. W. Bogart, Waterbury Clock Co.; T. E. Bowne, E. Ira Richards & Co.; F. S. Ottley, Riker Bros.; J. C. Kennedy, Parisian Specialty Co.; H. Muller, H. Hohenstein & Co.; Jacob Schorsch, I. Emrich & Co.; Mr. Bixby, for Frank W. Smith; M. Stratton, Jr., Alling & Co.; Arthur Bradshaw, Meriden Britannia Co.; W. J. Lane, Geoffroy & Co.; R. G. Monroe, for Wm. Scheer; Arthur A. Wheeler, for Louis W. Hraba; Chas. H. Singleton, Adams & Singleton; Walter S. Noon, W. F. Cory & Bro.; W. E. Pearse, Howard Sterling Co.; Daniel Dodd; J. Rothschild, Ingomar Goldsmith & Co.; H. E. Kingman, Arnold & Steere; M. F. Untermyer, Woodside Sterling Co.; W. S. Dudley, Rogers, Smith & Co.; Theodore L. Parker, Osmun-Parker Mfg. Co.; Jos. Levy, Hirsh & Bro.; A. H. Oakley, for Thornton Bros. and Walter E. Hayward; E. W. Dellar, Wm. S. Hicks' Sons; Lawrence H. Smith, Bippart & Co.; Benj. Schloss, A. Wallach & Co.; Frank W. Harmon, M. B. Bryant & Co.; O. J. Somers, for I. Ollendorff; F. B. Bingham, Bugbee & Niles Co.; J. O. Otis, Harvey & Otis; Geo. Goldberg, W. & S. Blackinton; Mr. Ledos, the Ledos Mfg. Co.; C. F. Sweasy, Wm. B. Kerr & Co.; James Panton, Mabie, Todd & Bard; F. C. Somes, S. O. Bigney & Co.; Le Roy Thompson, for F. W. Sackett.

**GOLD-HEADED CANES ARE A SPECIALTY WITH US.**



Write for an illustrated sheet. You'll be surprised at the large and handsome line we make.

**SIMONS, BRO. & CO.,**

Silversmiths,

Thimble Makers and Manufacturing Jewelers.

PHILADELPHIA,  
616 Chestnut Street.

NEW YORK,  
19 Maiden Lane.  
41 Union Square.

CHICAGO,  
702 Columbus  
Building.

**THE "PRISCILLA,"  
STERLING SILVER.**

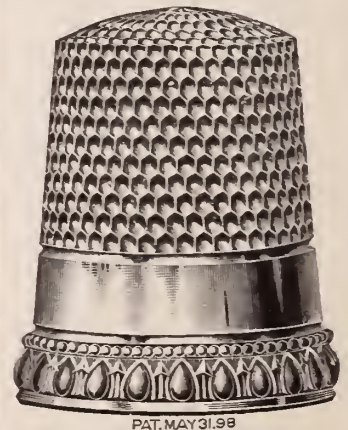

PAT. MAY 31, 1898

Our Catalogue shows a great variety of Gold and Silver Thimbles.

**The Latest Patents.**

ISSUE OF OCT. 31, 1899.

**635,760. WATCH REGULATOR.** OSCAR F. ENGWALL, Chicago, Ill., assignor of two-thirds to Charles D. Peacock, Jr., and Axel Bonde, same place. Filed June 7, 1897. Serial No. 639,690. (No model.)

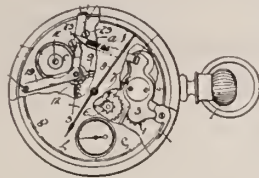

A timepiece having in combination a regulator for controlling its speed; the hand-arbor wheel; a setting stem; a disengageable gear connection between said regulator and hand-arbor wheel; a movable yoke connection between said setting stem and hand-arbor wheel and means having operative connection with the said movable yoke connection and disengageable gear for automatically disengaging the latter from the hand-arbor wheel when the said movable yoke connection is disconnected from the hand-arbor wheel.

**635,768. CLASP.** MARCUS T. GOLDSMITH, New York, N. Y. Filed May 20, 1898. Serial No. 681,191. (No model.)

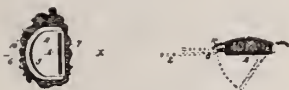

As a new and improved article of manufacture, a clasp comprising a face plate or shield, a metal box soldered or otherwise secured to the back of said face plate or shield and curved or rounded at its front or clasp side, a clasp bar hinged at its ends in the side walls of said box and adapted to close over the said front or clasp edge of the box, and a bar at the back of the box.

**635,826. JEWEL SETTING.** ALBERT WANDRY, Fort Worth, Tex. Filed April 17, 1899. Serial No. 713,315. (No model.)

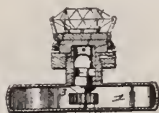

A device of the class described comprising a casing designed to contain a movement and having a projecting sleeve adapted to be arranged in a buttonhole, a spindle or arbor extending through the sleeve into the casing and designed to be geared with the movement, and a setting carried by the spindle or arbor and provided with means for detachably engaging a stone.

**635,895. ENGRAVING MACHINE ATTACHMENT.** ARCHIE A. MACCALLUM, Magog, Canada. Filed May 4, 1899. Serial No. 715,597. (No model.)

**635,901. METHOD OF ENAMELING ON SILVER LEAF.** CARL C. SCHIRM, Berlin, Germany, assignor of one-half to Albert Silbermann, same place. Filed Oct. 30, 1896. Renewed May 26, 1899. Serial No. 718,421. (No specimens.)

The process of enameling on silver leaf, consisting in producing a silver leaf with minute perforations, applying such leaf on a suitable base, the perforations permitting the air or gases to escape from between the surfaces of the leaf and base, and enameling said silver leaf.

**635,971. CONNECTED STUDS.** BRADFORD NORMAN, Portsmouth, R. I., assignor to Mabel Norman, Newport, R. I. Filed Aug. 1, 1899. Serial No. 725,798. (No model.)



The combination of a plurality of shirt studs, rigid distance pieces serving to hold the studs in separated relation to each other, and endwise movable connections between the studs to permit a ready adjustment of the studs toward and from each other.

**635,985. CUFF BUTTON LINK.** CHARLES TILGNER, New York, N. Y. Filed Dec. 20, 1898. Serial No. 699,877. (No model.)



An open link for cuff buttons, formed of a single piece of spring metal, having side bars and end bends, the end portions of the said piece of metal lying side by side, one overlapping the other, and the outermost end portion terminating opposite one of the end bends, whereby the link is double at such open end.

**636,176. EYEGLASS CASE.** WILLIAM M.



PURDY, New York, N. Y., assignor to Theo-

dore Mundorf, same place. Filed Jan. 10, 1899. Serial No. 701,771. (No model.)

A case for eyeglasses, having a longitudinal stiffening core within one edge, provided with a central recess accommodating the clips and a flexible cover about the core and receiving the eyeglasses.

**636,186. SPEED RECORDER AND ODO-**

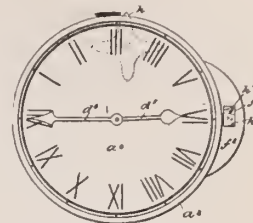

METER. HORACE G. SADGROVE, Birmingham, England. Filed Nov. 21, 1898. Serial No. 697,026. (No model.)

**The "Cherub" PENCIL**



**AMERICAN TOOLS ARE THE CHEAPEST**

Because they are the Best and Parts can always be duplicated quickly.

FOR SALE BY ALL JOBBERS. SEND FOR OUR NEW ILLUSTRATED CATALOGUE.

**CARD CASES... Ladies' or Gentlemen's.**

**Sterling Mounted.**

SPECIAL LINES FOR JEWELERS.



**C. F. RUMPP & SONS,**

FINE LEATHER GOODS,

Fifth and Cherry Streets, - Philadelphia.

New York Salesroom: 621 Broadway.

Send for Illustrated Catalogue...

**SEE THE TWO ANCHORS AND THE NAME ROGERS**

TRADE MARK:

...ON...

Like This  **ROGERS**  **"ANCHOR" BRAND**

**Silver Plated Ware.**

Get the Silverware which bears the above impression and then nobody can have any better than you'll have in the ROGERS all the time. Same through and through quality all the time. The Rogers Anchor Brand is made only by us.

Factories:  
Hartford, Conn. Norwich, Conn.  
Wallingford, Conn. Taunton, Mass.

**WM. ROGERS MFG. CO.,**  
HARTFORD, CONN.

DESIGN 31,730. BADGE OR SIMILAR ARTI-



CLE. JOHN W. MEALY, Baltimore, Md. Filed Sept. 30, 1899. Serial No. 732,237. Term of patent 7 years.

DESIGN 31,731. LINK CUFF BUTTON. JAMES



EDWIN HILLS, New York, N. Y. Filed April 25, 1899. Serial No. 714,459. Term of patent 7 years.

DESIGN 31,732. SPOON. CLARENCE L. WATSON, Attleboro, Mass., assignor to the Watson & Newell Company, same place. Filed Oct.



7, 1899. Serial No. 732,971. Term of patent 14 years.

DESIGN 31,733. HANDLE FOR SPOONS, &c. HENRY L. WALLACE, Wallingford, Conn.,



assignor to the R. Wallace & Sons Mfg. Co., same place. Filed Oct. 2, 1899. Serial No. 732,413. Term of patent 7 years.

DESIGN 31,734. HANDLE FOR BUTTON HOOKS OR SIMILAR ARTICLES. FRANK J. DIACONT, Providence, R. I., assignor to the Waite, Thresher Company, same place.

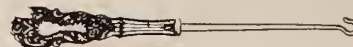

Filed Oct. 9, 1899. Serial No. 733,101. Term of patent 3 1/2 years.  
DESIGN 31,735. BACK FOR BRUSHES OR SIMILAR ARTICLES. FRANK H. LA



PIERRE, East Orange, N. J. Filed Sept. 27, 1899. Serial No. 731,869. Term of patent 7 years.

DESIGN 31,736. BACK FOR BRUSHES OR SIMILAR ARTICLES. FRANK H. LA



PIERRE, East Orange, N. J. Filed Sept. 27, 1899. Serial No. 731,870. Term of patent 7 years.

DESIGN 31,738. BOWL OR VESSEL. BENJA-



MIN DAVIES, West Hoboken, N. J., assignor to L. Straus & Sons, New York, N. Y. Filed Sept. 29, 1899. Serial No. 732,117. Term of patent 7 years.

HAVE YOU SEEN that pretty line of...

**REVOLVING SHAVING MIRRORS?**

Call and see them.

Also new ideas in TRIPPLICATES.

THE BEST SELLER OUT.

**SELWYN IMPORTING & TRADING CO.,**

14 East 17th Street, New York.

**BONNER & CO.,**

Manufacturers of

**FINE DIAMOND MOUNTINGS,**

57 MAIDEN LANE, NEW YORK.

**ALOIS KOHN & CO.,** 4 MAIDEN LANE, SOLID GOLD CHAINS, Near Broadway, N. Y.

We call the attention of the Trade throughout the country to our line of

**LORGNETTE AND GUARD CHAINS.**

Will send Samples on Memorandum on receipt of satisfactory reference. Correspondence Solicited.

Established 1879.

Manufacturer of

**LOUIS W. HRABA, Fine Leather Goods**

29 East 19th St., New York.

Exclusively for the Jewelry Trade.



**Eaton-Engle Engraving Machine.**

CATALOGUE AND SAMPLE OF WORK FREE.

**EATON & GLOVER** have removed to the FULTON BUILDING, 87 NASSAU ST., Cor. Fulton, N. Y.



GOLD SHELL.

"Buy direct from the manufacturer and get all that is coming to you."

SEND FOR OUR "HOT CATALOGUE, CONTAINING GOLD FACTS AND PRETTY PICTURES."

**CLARK & COOMBS,**

86 WEST EXCHANGE ST., PROVIDENCE, R. I.

WE ARE HEADQUARTERS FOR.....

**Gold Shell Rings...**

**EXPIRED PATENTS.**

[The following list of recently expired patents of interest to the trade is furnished by R. W. Bishop, Patent Attorney, Washington, D. C. A copy of any patent may be had from him for 10 cents.]

- 266,611. BUTTON. JOHN COSTELLO, Attleboro, Mass., assignor to Watson & Newell, same place.
- 266,620. SWIVEL. JOHN HANCOCK and LEVI RICHARDS, Providence, R. I.
- 266,737. WATCH SPRING. E. J. WATSON, and H. W. WILLSON, Worcester, Mass., assignor to the Washburn & Moen Mfg. Co., same place.
- 266,826. MUSIC BOX. ALBERT JEANRENAUD, St. Croix, Switzerland, assignor to M. J. Paillard & Co., New York, N. Y.
- 266,869. RING. NOAH MITCHELL, New York, N. Y.

**ESSER & BARRY,** Largest Manufacturers of Imitation Diamond Jewelry in America. Cheap and Medium Priced.

Write us for samples of almost anything with an Imitation Diamond in it.

MAIN OFFICE AND FACTORY, 101 SABIN ST., PROVIDENCE, R. I.

DEPARTMENT OF  
**ADVICE AND CRITICISM**  
 ON  
**RETAIL JEWELERS' ADVERTISING.**

[This department is free to every retail jeweler and optician. Forward for criticism your newspaper ads, booklets, catalogues, novelties, circulars, etc. Ask advice and offer suggestions. Replies in these columns are unbiased. Make letters full and particular as desirable. Every letter and ad. sent will receive full attention, though the publication of the matter may sometimes be delayed some weeks. Address all letters and other matters to The Jewelers' Circular Pub. Co., 11 John St., corner Broadway, New York.]

**PART LXXXI.**

LINCOLN, Ill.

Editor of THE JEWELERS' CIRCULAR:

I enclose some ads. which I have been running with success. If you could take copies of the German ads. they may be of interest to your readers, by using the German type in your paper. I sent you a copy of a large ad. I ran in a German paper two weeks ago. It may have been of interest to you. I change my ads. each week and

glasses, though the grammar is slightly faulty. Solecisms in grammar also occur in the "The Point is This" ad. If Lincoln, Ill., and vicinity have a considerable population of Germans, addressing them in the German vernacular is undoubtedly fruitful of good results.

The advertising matter accompanying Mr. Brown's letter consists of some tissue photograph envelopes and some photograph cards. In the upper part of the former is an ad. of the photographer, while below is that of the jeweler. On the front of the cards is the photographer's name, etc., while the back contains a displayed advertisement of the jeweler. This mutual advertising is undoubtedly profitable, though we think the jeweler has the best of the bargain. His business is advertised widely at little or no cost by means of the circulation of the photographs.

**A Good Cleaning Agent.**

**P**OUR 1 kilo of spirits of sal-ammoniac together with the like quantity of water and add about 100 grammes of finely shaved

**DON'T STUMBLE**



Through the world. Let some good fairy of an optician fit you out with some eyes. Don't be ashamed to wear glasses. It will give you an intellectual look, and then how nice it will be to be able to recognize friends across the street, and by returning their bow to explode the idea that we are of a haughty and unkind nature.

If we fit your glasses, you will have no trouble with them or your eyes. We would be pleased to have you come to us whenever you need our services.

J. E. CARLSON, Optical Expert, will be at my store every Thursday, Friday and Saturday.

**A. J. REINHARDT, Leading Jeweler,**  
 526 Broadway. Lincoln, Ill.

**Jedes Kindchen,**



Ob Knabe oder Mädchen, kann glücklich gemacht werden durch den Ankauf eines Kinder-Setts. Der Preis ist im Bereich eines Jeden, von \$1.00 bis \$5.00 per Set, je nach Qualität.

**Die Auswahl ist eine großartige!**

**Adolph J. Reinhardt,**

Der leitende Juwelier Lincoln's,  
 536 Broadway, Lincoln, Ill.

run ads. in 11 papers of the country. I never run same ad. twice in a paper. I find a new ad. always catches the eye and is read. I wish THE CIRCULAR success. Yours truly,  
 A. J. REINHARDT.

NEWPORT, Vt.  
 Editor of THE JEWELERS' CIRCULAR:  
 We enclose what we think is a new scheme in advertising. As we do all our own printing it, of course, is not very expensive to us. We print

yellow soap. The whole should be kept ready for use in a glass vessel with tightly closing cover; if the glass has an even rim, a piece of plate glass may serve for a lid.

**The Point is This!**



Woman are fond of nice things, and when they want something nice in the Jewelry line they know that A. J. Reinhardt carries the largest and most complete stock of Silverware, Cut Glass and Plate ware in Logan county. His prices are the lowest. Call and be convinced.

**A. J. REINHARDT,**  
 LEADING JEWELER,  
 526 Broadway. Lincoln, Ill.

**Barnum's weißer Elephant...**



War über die ganze Welt bekannt. Unsere niedrigen Preise möchten wir an alle Einwohner von Lincoln und Logan County bekannt machen. Deshalb besucht uns!

**Silver Cream Polish**, 25c per Flasche, ist das beste Präparat in der Welt für Silber- und Goldwaaren zu reinigen und zu polieren. Deshalb also mattes Schmuckzeug tragen, wenn dieses Präparat sie stets wie neu glänzend erhält.

**Adolph J. Reinhardt,**

Der leitende Juwelier Lincoln's,  
 536 Broadway, Lincoln, Ill.

All these advertisements are good, and are open to little criticism. The cuts are pat and the arrangement of the matter clear and attractive. The optical ad. especially is a good argument for the wearing of

the photographer's ad. at the top of the tissue paper enclosure for the use of our ad. at the bottom of same, so that the expense to us is only the work of printing same. I also enclose a card that they use for pictures, which they put out at 15 cents a dozen. We print their ad. on front of card for use of back of the same. Respectfully,  
 F. A. BROWN.

Into this mixture dip all metal articles to be cleaned, for one-half to five minutes. Then rinse off the objects in water, brush them over wet with whiting and dry them in some manner. Watch chains and jew-

# SUSSFELD, LORSCH & CO.



Ask your jobber for  
our lines of Optical  
Goods.

## Reading Glasses

in

### Pearl and Gilt

as well as with

### Black Handles

AND NICKEL MOUNTED.

## Opera Glasses

in latest styles.

37 & 39 MAIDEN LANE,  
NEW YORK.

elry are best laid into sawdust, while parts of watches are preferably brushed dry with a dry brush and some polishing chalk, taking special care that the wheel teeth are not omitted. The dirt from the pinion leaves is best removed with the buff stick, which operates more easily and thoroughly than anything else. This detergent dissolves everything; grease, resinified oil, oxide, only not iron rust. It is essential to fully immerse all the pieces. Whatever remains above the liquid tarnishes slightly and the dividing line remains visible. For this reason the above stated quantity is necessary for large pieces. According to a German exchange, this medium is suitable for gold and silver ware which has turned brown, spoons, jewelry, argentan ware, watch chains, as well as for small and large parts of timepieces. The last are together suspended from a wire immersed and rinsed off in water. Watch wheels need not be chalked wet; it suffices to brush them dry on both sides and over the teeth with polishing chalk, but they must not dry before, else they do not become clean. After the pinion leaves have been gone over with the buff stick, all the parts are bathed in benzine, in order to remove any adhering dust, and the cleansing is finished. The cylinder and the horizontal wheel will look like new again, while otherwise it is known to be a difficult task to clean these parts of resinified oil, which is not dissolved by benzine. Watch cases may be left about 10 minutes in the mixture; after rinsing off and drying they are slightly heated, so as to remove the water from the joints and hinges.

Gilt parts, which are not spotted or soiled, but spoiled by wear or polishing, cannot, of course, be changed. But non-gilded wheels become wonderfully clean, and every lover of neat cleaning will take pride in a timepiece thus cleaned. Parts with stones cemented in must not be placed in the mixture, because it dissolves the shellac.

### Recognizing Gems.

THE *Sun* told not long ago of a woman who had taken a diamond ring to be cleaned by a jeweler and could not be persuaded that the stones returned in it were her own. Another similar case is reported. A New Yorker sent a ring set with several large pearls to a jewelry establishment to be cleaned. When it was returned he immediately notified the firm that a mistake had been made. The jeweler was certain that the right pearls had been replaced in the setting, and offered the customer the privilege of looking through his stock of unset pearls to convince himself. This course was followed and all the unset pearls in the store were shown. The customer picked out two which he identified as his own to the satisfaction of the jeweler. A mistake had been made which the proprietors were not at first inclined to think possible.—*The Sun*.

### The Delaware Ophthalmic College

(INCORPORATED.)

We haven't time to say very much—business is the word. Send for our catalogue and compare it with others, and you will see for yourself where the best school is in the U. S. A. to get an optical education. Two courses, attendance and correspondence.

Dr. R. S. STEPHENS, President, DOVER, DEL.

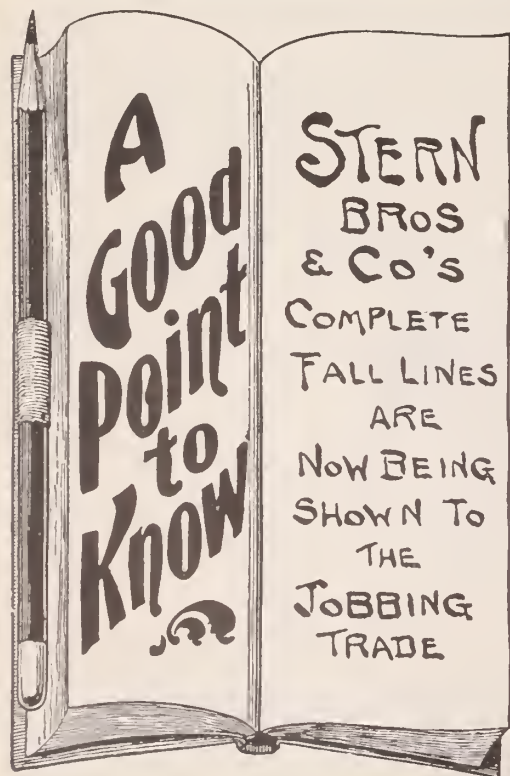

RINGS,  
BROOCHES,  
LOCKETS,  
SCARF PINS,  
THIMBLES,  
DIAMOND  
MOUNTINGS  
....AND....  
DIAMOND  
JEWELRY.

33-43 Gold Street,  
NEW YORK.

149 State Street,  
CHICAGO.

518 Market Street,  
SAN FRANCISCO.





## PRACTICAL COURSE IN ADJUSTING.

### COMPRISING

*a review of the laws governing the motion of the balance and balance spring in watches and chronometers, and application of the principles deduced therefrom in the correction of variations of rate arising from want of isochronism, change of position and variation of temperature.*

### ELUCIDATED AND DEMONSTRATED BY

*original experimental researches in the actual problem, never before published, showing the causes that are operative in the variation of rate and leading to correct remedies.*

BY THEO. GRIBI.

Copyright by Theo. Gribi; assigned to THE JEWELERS' CIRCULAR PUB. CO.

[COMMENCED IN ISSUE OF FEB. 1, 1899. PART XXI.]

### CHAPTER III. (Continued.)

**16. Auxiliary Compensation.**—The characteristic variation of the rate of chronometers, illustrated in Fig. 27, is called "secondary error." The cause of it is not well defined; for, not only does it differ quantitatively in different chronometers, but two balances of the same lot, made of the same piece of metal, and in precisely the same way, may have widely different curves, the one being flatter than the other. As a rule, chronometers giving flatter curves are preferred, for the ideal compensation would be that which would give a straight line; but no objection is raised in the naval service to one giving a strong curve, provided its rate is sufficiently regular. Many attempts have been made to overcome, or at least to reduce, this secondary error by the application of what is known as auxiliary compensation, but with only partial success. It would be beyond the scope of this work, designed, as it is, for the benefit of the watchmaker mainly, to enter into a description, as well as the merits of the various devices proposed and used to accomplish this end, their usefulness being restricted to ship chronometers. Nevertheless, a statement of the principle upon which they work, or ought to work, seems in place.

By reference to Figs. 26 and 27 we see that with the ordinary compensation balance the chronometer loses in both extremes of temperature. This shows that the effect produced by the compensation is too great in the low temperatures and not sufficient in the higher ones. Returning to Fig. 25, and the explanation there given of the movement of the rim of the balance under changes of temperature, the reader may be able to see why this is the case, and to apprehend the nature of the remedy required. The portion of the rim of the balance comprised between the points b and c, with its compensating weight, moves toward the center in a rising temperature, tending to make the actual diameter of the balance smaller and thereby to make the chronometer gain. The fact that it still loses in the high temperature shows that the

weight does not move near enough to the center. Again, under a decreasing temperature, the same portion of the rim moves away from the center, tending to make the balance larger, and thereby to make the chronometer lose. The fact that it goes slow in the low temperature proves that the weight moves too far away from the center; that, in fact, it overcompensates in that temperature. The principle, therefore, upon which an auxiliary compensation should work is that of increasing the effect of the compensation in the high temperature and checking it in the low. To state the work required of an auxiliary compensation in terms of the mechanics of motion: it must diminish the active diameter of the compensation balance, in other words its moment of inertia, in both high and low temperatures. The ideal form of an auxiliary compensation, therefore, would seem to be that of an additional weight moving toward the center in both extremes, starting from the mean temperature.

Very few of the auxiliary compensations in use fulfil this law; most of them are operative in one direction only. Some of them have the effect of reversing the rate curve—*i. e.*, of making the chronometer gain in both high and low temperatures. One of the worst effects of a bad auxiliary is, that the curve produced by the rate is quite irregular, and, therefore, not subject to any formula for its calculation.

Some years ago there was instituted at the observatory of Geneva, Switzerland, a national competitive trial of marine and pocket chronometers, specially designed to study temperature error and the effect of compensation, including auxiliary compensation. An exhaustive report of this work was published under the auspices of the "Journal Suisse d'Horlogerie" in 1885, the only work of its kind published in which temperature error in connection with watches has ever been treated. The trial was made with 61 timepieces—7 marine chronometers and 54 pocket chronometers. They were subjected to a temperature ranging from 5° to 35° centigrade (41° to 95° F.), during seven periods of five days each; first in a temperature of 5°, then in one of 10°, of 15°, and so on in ascending order of temperatures, five degrees apart; and again in the same way in descending order of temperature from 35° to 5°. The result of this trial is of exceeding great value, well worth the perusal of the reader who desires to study the subject. In this trial the value of auxiliaries was brought out in a prominent way. The result showed that, while they generally diminish the secondary error, quantitatively, they cause considerable variation, producing generally very irregular curves, often crossing and recrossing the line of mean compensation several times between the extremes of temperature. One of the points brought out was the curious freak that the curves produced by the rates during the ascending periods of the trial differ in many cases considerably from those of the descending periods, some of them being exactly reversed. This

seems to be the case particularly with those which had been recently adjusted, while several whose adjustment dated back to longer periods, one of them in particular, which had been adjusted some years before, gave curves almost identical for both ascending and descending periods.

In this trial, account was taken of the difference, as to the effect upon compensation error, between steel and palladium springs, a point which I have not thought worth while to touch upon in the foregoing investigations. It showed that, while, in general, the secondary error was smaller with palladium springs, the compensation curve for the steel springs was more regular and generally parabolic in shape. This could hardly be in-

terpreted as tending to show a superiority in the palladium spring.

There was brought out, too, in this trial, the fact, mentioned before, that two watches made by the same maker, identical in construction, balance and balance spring, gave totally different rate curves. While, therefore, the result of this trial in general corroborated the parabolic form of curve in watches, too, in particular it brought out many irregularities and exceptions. It follows that, even if watches were not subject to position error while being carried, a factor of much greater importance in their case, it would be useless to attempt to apply a rigid formula for the reduction of their rate in variable temperature.

(To be continued.)



DIAL.



WORKS.

20,000 FRANC WATCH TO BE EXHIBITED AT PARIS EXPOSITION OF 1900 (SEE PAGE I.)

### Determining the Age and Value of Antique Watches.

1. WATCHES were invented around the year 1500. The oldest specimens are cylindrical in shape and made entirely of iron, the plates, as well as the pinions, wheels, cocks and pillars.

2. Oval watches (egg watches) are not met with before the middle of the 16th century; most of them date back to the period around 1600.

3. Enamel painting in colors was invented in 1632, hence there were no watches decorated with enamel till that time.

4. The balance spring, invented as far back as 1658, but only rarely employed, did not become more general until about 1690.

5. Watches with alarm were already carried in the 16th century, but repeaters were not invented before 1676.

6. The minute hand was introduced only with the use of the balance spring, hence is not met with till the end of the 17th century.

7. The cylinder escapement, though in-

vented in 1710, is only found in isolated cases in the 18th century. Almost all time-pieces till the beginning of the 19th century were vertical watches.

8. Watches with chased cases do not occur before the beginning of the 18th century.

9. Watches with "quatre couleurs" cases are not found before the year 1790; watches with gongs not before 1780.

10. Watches with movable figures on the dial and musical watches occur only around 1800.

11. Watches set with pearls fall about in the same period.

As regards the value of antique watches, the following may serve as a guidance:—

More or less valuable are:

1. All watches of the very oldest kinds.

2. Egg watches.

3. All watches with but one hand, because they generally have artistically engraved cocks.

4. Watches with fine open-work or nicely chased cases.

5. Gold enameled watches, which are enameled both on the inside and outside.

6. Watches in general which are handsomely decorated in any respect.

Not valuable are:

1. Chased watches whose figures are worn off.

2. Watches with painted tombac cases (copper enamels).

3. Watches with cases "à quatre couleurs" (application of gold in four colors) unless very beautifully executed and well preserved.

4. Watches with painted copper dials.

5. Enameled watches which are injured.

6. All watches which are devoid of any artistic decoration, hence silver and gold watches with plain cases and unadorned dials, no matter what kind of works they have.—[From "Taschenuhren früherer Jahrhunderte," by G. H. Horstmann.]

### Weight and Size of the Balance.

*Almanach des Horlogers.*

THE regulating power of a balance is measured by its mass or weight at the circumference multiplied by the square of the velocity. The weight which is of utility is at a distance from the center; that is why care is taken to make the rim as thick as possible, and even to increase its mass with screws and otherwise. For the same reason the center and the cross arms or bars are diminished as much as possible. The velocity is measured by the space passed over in a given time by a point in the circumference. If, then, the diameter of a balance is increased, its regulating power will also be increased. Large balances are preferable to small ones. If two balances of equal weight and of equal velocity at the circumference are of unequal sizes their regulating power will be the same, but the large balance will have the advantage of being exposed to less friction because its angular movement will be less. Its arc will have a less number of degrees than the arc described by the small balance.

It is better to use a balance as large as possible and relatively light, making quick vibrations, rather than a large, heavy balance vibrating slowly. The diameter of a balance and the number of vibrations it ought to make being given, it is better to cause it to move through large arcs than to augment the mass at the expense of the velocity.

If two balances are of the same power their weights will be in inverse ratio to the squares of their velocities. If two balances are of equal weight but of unequal velocity their powers will be in the

same ratio as the squares of their velocities. If their velocity is equal the powers will be in the same ratio as the weights. If the weight and the velocity are unequal the powers will be in the ratio of the weights multiplied by the squares of the velocities.

By the aid of these principles, when the weight of a balance, its diameter, its velocity and the force which maintains its movements are known, the new conditions requisite for every other balance differing in weight, diameter and velocity, and actuated by a different force, can be ascertained.

Balances cannot have a uniform weight and size, for these two elements are determined by several laws of proportion derived from the motive force, the dimensions of the train and other variable data. The determination of the weight and diameter of the balance in relation to the wheel work and escapement has always been, and still is, the object of close research.

**Workshop Notes.**

**Varnish for Oxidized Silver.**—Alcohol (95 per cent) 16 parts, red arsenic 3 parts, lavender oil 1 part.

**Preparation of Nitrate of Silver.**—To obtain argentic nitrate, dissolve this metal in nitric acid, evaporate the solution until reduced to about half. After cooling nitrate of silver in crystals remains, which must be kept away from the light.

**Transparent Varnish.**—Powdered sandarac 100 grammes, turpentine 175 grammes, spirit of turpentine 700 grammes. Dissolve the sandarac in the water bath and the turpentine in the spirits of turpentine. Before using this varnish expose the flask to the sun for about one hour.

**Electric Brass Bath.**—An effective galvanic brass bath is prepared as follows: 20 grammes of the double salts of potassium cyanide with zinc cyanide and copper cyanide, 4 grammes of sodium carbonate, 0.75 gramme of chemically pure potassium cyanide and 0.75 gramme of ammonium chloride are dissolved in water heated to 20—25° C. With a tension of 3—4 volts an even coating of brass can be precipitated in this bath upon all metals.

**Solder for Glass.**—A metallic compound which firmly adheres to glass, and can, therefore, be employed as a solder for glass, says *Gold und Silberwaren Industrie*, is obtained by melting together 95 per cent

(by weight) of tin and 5 parts of zinc. The melting point lies at about 200° (C.). By means of a soldering iron it can be spread upon the glass, previously heated to this temperature, and, after cooling, adheres firmly to it. An alloy of 9 parts tin and 1 part aluminium may be used for the same purpose, but has the drawback that its fusing point lies considerably higher, viz., around 300°.

**Gilding or Silvering of Horn.**—In order to gild horn, it does not require a grounding, as in the case of wood, since, on the one hand, the layer would be too thick to look well, and, on the other hand, would crack off, owing to its thickness. For this reason horn work to be gilded is thinly coated with gilder's varnish and, before it has become perfectly dry, the leaf metal is applied as smoothly as possible. Next, press it down with cotton, allow to dry several days, remove the superfluous metal with a soft brush, and, finally, smooth with the burnisher. If arabesques or other or-

naments are to be put on, stamp the design on the material, execute the lines with gilding varnish and apply the leaf metal as before. Bronzing of horn is accomplished by either priming the whole surface or executing the whole design with gilding varnish, then sprinkling on the powdered bronze, and, after complete drying, sweeping off any superfluous bronze with a soft brush. In silvering horn, same must likewise be perfectly free from grease and is painted with a saturated solution of gallic acid, and next with a solution of 20 parts of argentic nitrate in 100 parts of water. The application is repeated alternately until the black coloring is replaced by a faint silvery gloss, when another coating of silver solution is applied. Rubbing with tartar solution completes the silvering.

Strangers to negotiable paper, who put their names on the back of it prior to its delivery to the payee, or to a bona fide holder, become responsible as co-makers.

**JULES JÜRGENSEN,**  
COPENHAGEN,  
**Plain and Complicated WATCHES AND CHRONOMETERS,**  
Are the leading production of their kind in the world.  
SOLE AGENTS  
**Schulz & Rudolph,**  
*Importers and Cutters of Diamonds  
and Other Precious Stones....*  
28 JOHN and 65 NASSAU ST., NEW YORK.

**PATEK, PHILIPPE & CO.,** GENEVA, SWITZERLAND,  
MAKERS IN THE HIGHEST QUALITY OF  
**Fine, Plain, Complicated  
And Decorated Watches**  
IN 15 DIFFERENT SIZES. INTERCHANGEABLE PARTS.  
NEW YORK OFFICE, 68 NASSAU ST. ALFRED G. STEIN, Representative.

**THE TRUE BLUE**  
Beaded Label Watch Glasses,  
MADE IN  
**FRANCE.**

ASK YOUR JOBBER FOR THEM.  
**SUSSFELD, LORSCH & CO.,**  
21 Rue de L'Echiquier, PARIS.  
LORSCH BUILDING,  
37 & 39 Maiden Lane, NEW YORK.



**WATCH GLASSES**

BEAR THE  
BEADED LABEL.

BEWARE OF  
IMITATIONS.

THE GENUINE  
ARE LABELED



**FRANCE.**

# BRADLEY & HUBBARD MFG. CO.

Have produced for this season's trade  
the finest line of goods ever offered.

## Art Metal Goods, Reception Lamps

PITCHERS, VASES, CANDELABRAS,  
FIGURES, BUSTS, TABLES, ETC.....

WITH THE CELEBRATED "B. & H." and B. & H. RADIANT BURNERS.  
NEW AND ORIGINAL DESIGNS.  
HANDSOME AND EXCLUSIVE FINISHES.

*Dealers are cordially invited to inspect the line of Samples  
at our SALESROOMS.*

NEW YORK: 26 Park Place to 21 Barclay Street.

BOSTON:  
160 Congress Street.

CHICAGO:  
131 Wabash Avenue.

PHILADELPHIA:  
714 Betz Building.

FACTORIES and OFFICES: MERIDEN, CONN.

# THE SWAN FOUNTAIN PEN.

Reputation World Wide.  
Made upon Distinct Principles.  
Is a Compressed Air Pump.  
Simply Wet the Insides to Provoke  
an Energy.

W. W. Stewart, Inventor and Patentee.

A variety of Styles and Prices

- 3 Sizes Safety Swans.
- 3 Sizes Self-filling Swans.
- 3 Sizes Adjustable Feed Swans.

MABIE, TODD & BARD,  
NEW YORK AND LONDON.

# FERD. FUCHS & BROS., SILVERSMITHS,

MAKERS OF STERLING SILVERWARE,  
34 East 29th St., - New York.

WOOD & HUGHES,  
Sterling Silverware Manufacturers,  
FINE PLATED WARE,  
No. 24 John Street, - New York.

# WM. SMITH & CO.,

GILL BLDG., 9-13 MAIDEN LANE, N.Y.  
61 PECK ST., PROVIDENCE, R. I.

ESTABLISHED  
1854.

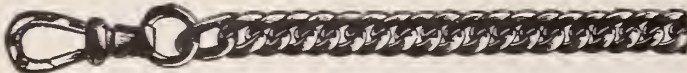

MANUFACTURED  
BY

## Gold, Silver and Rolled Plate Chains and Jewelry.

Novelties in Gold and Silver Bracelets. Also a large line of Chain Trimmings.

# THE F. KROEBER CLOCK CO., IN LIQUIDATION

ARE DISPOSING OF THEIR LARGE STOCK OF  
CHOICE

## Eight-Day and One-Day Clocks

CONSISTING OF

Porcelain, Iron, Bronze, Gilt and  
Wood Clocks

AT A

## REDUCTION

INSTEAD OF AN ADVANCE.

SALESROOMS AT

360 BROADWAY, - - NEW YORK.



EIGHT-DAY PARIS No. 2.

Beveled Glass on Front, Rear and Sides

HEAVY GILT, HEIGHT 13 1/4 inches.

PRICE, \$14.00 NET CASH.



## The Rambler's Notes.

WHAT THE RAMBLER SAW AND HEARD AMONG THE DEALERS IN ART POTTERY, CUT GLASS, BRONZES, ETC.

AMONG the CHRISTMAS NOVELTIES IN CUT GLASS. Christmas novelties in cut glass which C. Dorflinger & Sons are showing at their wholesale warerooms, 36 Murray St., New York, are many pieces and sets that will especially interest the jeweler having a trade for fine and exclusive productions. A neat little novelty in colored glass here shown is the new cordial set which comes with a decanter of half pint size, in ruby or green glass. The decanter and the cordial glasses are decorated alike with the firm's latest patterns in cuttings or stone engravings.

A SPECIAL drive is now being made by the Pairpoint Mfg. Co. in their lines of decorated porcelain and glass productions, including their Crown Pairpoint china, Crown Milano glass and other wares, which are now being offered at their New York salesrooms, 38 Murray St., at decidedly advantageous terms. Among the pieces in decorated glass are shown assortments of cracker jars, collar and cuff boxes, sugar and cream sets, and like articles for the cabinet and boudoir, in decorations of various colors, with flower effects with gilt ornamentation. These pieces are trimmed with gold or silver mountings and are satin lined. In their Crown Pairpoint china are some very large and finely painted vases, being French china blanks decorated by American artists.

THE prevailing decorations in the finer grades of the G. D. A. china, now shown by Haviland & Abbot, 29 Barclay St., New York, seem to be large bands of one color with gold relief and lace work, pink being the shade apparently now most popular. Among the prominent of these decorations are some pink and green effects in which the green is in a shaded band, in some cases wide and in others narrow, superimposed upon a band of pink. These effects run through a full line of table ware sets and the usual novelties in china. Besides the many new decorations for this season, several pretty and original

shapes in entire lines are also here to be found.

THE RAMBLER.

## Colored Diamonds.

A LARGE number of diamonds are white, though a clear, colorless, transparent stone is rarer than might be supposed. Besides white diamonds there are red, blue, green, yellow, brown, black, and pink ones. Heat often changes the color, and after awhile the acquired hue becomes permanent. Yellow diamonds perhaps afford the greatest variety of shades. Some of them surpass any other gem of that color. Specimens of canary colored diamonds are quite common. If the gem has a rose colored tint it is very valuable, while red tints, surpassing the ruby, and considered the most beautiful of all precious gems, are exceedingly rare. A few varieties are on record; one weighing 10 karats was bought by Emperor Paul of Russia for one hundred thousand dollars. A cinnamon or brown stone is undesirable, as it is seldom pure. A black diamond is nearly as scarce as a red one. Blue diamonds rank next to red ones in variety and beauty. Those of a dark blue color, resembling sapphires, are handsome gems, differing only from the sapphire in quality and the beautiful play of colors peculiar to the diamond. The only real blue stones are found in the mines of India. Besides the Bismarck and Hope diamonds there are only two others in the world that are properly called blue diamonds.

The green varieties are not as rare as the blue, black, red, and rose colored species, yet a grass-green or fine emerald is scarce. When it does occur it is more brilliant than the finest emerald. There are several varieties of green tinted diamonds at the Museum of Natural History in Paris, but the best known specimen is at Dresden, and is considered one of the five paragons of the world among gems.—From *Self-Culture*.

## Clocks in Chaucer's Time.

MANY clocks with weights and wheels were in use in England during Chaucer's time, and most of the monasteries of the 14th century possessed clocks, though these were used to show the astronomical movements as well as the passage of hours. Throughout the 15th century clocks were made mostly by armorers and blacksmiths, as they were constructed of iron and steel.

## New Books of Interest.

**Old Clocks and Watches and Their Makers:** Being an historical and descriptive account of the different styles of clocks and watches of the past, in England and abroad. To which is added a list of 8,000 makers. With 400 illustrations, many from photographs. Demy 8vo., cloth, gilt, 512 pages. By F. J. Britten, author of "The Watch and Clock Makers' Handbook," etc. London: B. T. Batsford, 94 High Holborn, publisher. Imported by Chas. Scribners' Sons, 153-7 Fifth Ave., New York.

The present volume is a recast—with much additional matter—of "Former Clock and Watch Makers." The author is the secretary of the Horological Institute, Clerkenwell, London. He has had access to many celebrated specimens of the craft, including the British Museum, South Kensington Museum and Schloss Collections and, by special permission of the Queen, the fine display of 18th century clocks at Windsor Castle. Good paper, clear type and fine engravings add to the value of a work written by an acknowledged expert. Mr. Britten possesses an easy literary style and avoids using technical terms where they are not indispensable. Ordinary readers will find a fund of interesting matter, while professional readers seeking information as to the history and technique of their art will not be disappointed.

A chronological summary of incidents connected with the history of clocks and watches appropriately opens the volume. Some introductory remarks upon ancient methods of measuring time follow. The Chinese method of a burning wick knotted at intervals is possibly the oldest. Sun, moon and stars were consulted by the ancients. Sun-dials, water clocks or clepsydrae (in which the gradual falling of water was the motive) and, probably later, weight-clocks are described. Sand glasses were also of early origin.

Thirty or 40 pages suffice to give detailed accounts of famous early fixed clocks, special notice being taken of the Strasburg clocks and their elaborate mechanical contrivances. More interesting to many readers will be the section devoted to portable timekeepers, a term which includes not only pocket watches but also many other and much earlier timepieces. The author suggests that watches were not carried in the "fob" or pocket until about 1625. About 100 pages and 150 illustrations are given to this section. The curiosities illustrated and described include many differently shaped timekeepers: octagonal,

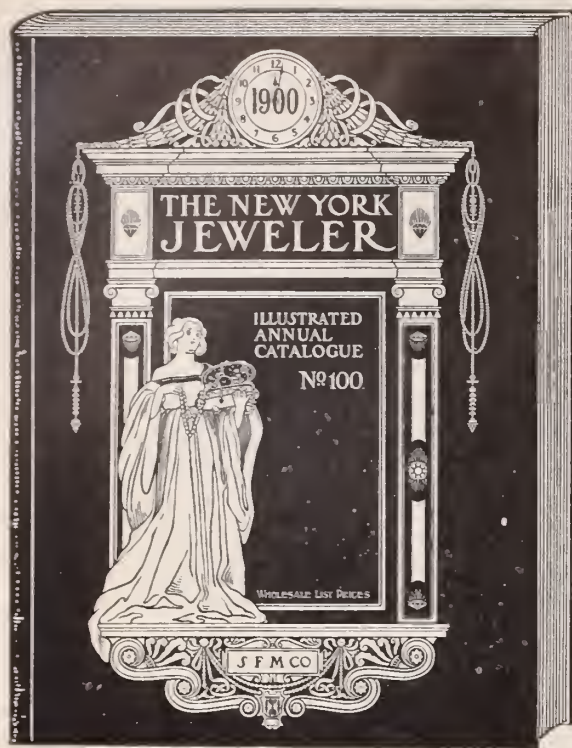

ILLUSTRATION 1-6 SIZE.

**S. F. MYERS CO.,** Manufacturers, Importers  
and Wholesale Jewelers,

MYERS BUILDING, 48 & 50 MAIDEN LANE, 33 & 35 LIBERTY STREET, N. Y.

Address Department No. U 10 when sending for catalogue.

## OUR NEW CATALOGUE

Just out.

List Prices Only.

724 PAGES, 9 x 13.

For 26 years the acknowledged authority for choice designs in reliable goods and the lowest prices current in the New York market.

WATCHES,  
DIAMONDS,  
JEWELRY,  
OPTICAL GOODS,  
SILVER NOVELTIES,  
MUSICAL MDSE.,

Clocks, Lamps,  
Cut Glass, Silverware,  
Fine Leather Goods  
And Stationery,  
Photographic  
Supplies,  
Jewelers'  
Sundries, Etc.

## The "Bryant" Rings.

ARE KNOWN TO THE JEWELER'S CUSTOMERS AS THEY ARE TO THE JEWELER, HAVING FOR 50 YEARS OCCUPIED THE PROUD POSITION OF "THE BEST."



THE "BRYANT" MARK IS ACKNOWLEDGED TO BE A GUARANTEE OF QUALITY, STYLE AND FINISH.

GOODS SENT ON APPROVAL TO RESPONSIBLE DEALERS.

Our new Fall line comprises a profusion of new designs.

**M. B. Bryant & Co.,**  
10 Maiden Lane, New York.

oval, Maltese cross, cruciform, star shaped, and designed to represent skulls, ships, books, padlocks, shells, fruits, flowers, insects, musical instruments and many other quaint forms. Many curious dials and cases are also illustrated. It is interesting to note that the fashion prevailing among ladies of wearing their watches exposed to view is a return to early usage, when they usually hung from the chatelaine.

The decoration of early watches was often very elaborate. The chapter on enamel painting—fashionable about the middle of the 17th century—deserves special attention. Queen Elizabeth owned many valuable watches. Some of gold, finely jeweled with diamonds, rubies, emeralds, pearls, opals and less expensive stones. The "skull" watches and clocks of the same period were very peculiar, the ghastly exterior contrasting with beautiful designs inside, including such subjects as the Nativity and the Garden of Eden. Biblical incidents are common in old watches and, in common with old scriptural prints, contain anachronisms in costumes, etc. Most of the "toy" watches are of French origin. Until the middle or end of the 17th century very few specimens of watches boast of minute hands. Plain enameled dials came in about the same time.

The Old Masters of the Craft, with portraits and illustrated specimens of their work, occupy over 100 pages. French Clocks and Cases in the French Style account for another 20; Mystery Clocks and Other Curious Timekeepers, 13. Succeeding chapters deal with The Progress of English Domestic Clocks, Long-Case Clocks, Bracket or Pedestal Clocks, Mechanism of Clocks and Watches, and Hall Marks.

The List of Former Clock and Watch Makers concludes the volume. It includes the best known London makers and many provincial and foreign ones; period, specialties, specimens extant, etc. It occupies 125 pages and while many noted American horologists are missing, is probably as complete as careful and painstaking research can make it.

### Clocks for Queer Uses.

[London Truth.]

ONE of the latest developments of the common domestic clock is worthy of serious attention. It comes from Switzerland, and takes the form of a phonographic attachment to an ordinary clock, which at any desired hour of the morning will shout: "It is (7) o'clock; get up! Now, don't go to sleep again!" The possibilities of an extension of this principle are immense. There might be clocks for the boxing ring, saying: "Time, gentlemen," and clocks for the parliamentary bore, with a cry of "'Vide 'vide!" Church congregations which have suffered many things at the hands of long-winded preachers might subscribe for a clock which should utter a sonorous "Amen" at the end of a suitable period. Equally valuable would be a time-piece which should convey a gentle hint to the unwanted caller; indeed, this particular development is so attractive that I am thinking of enlisting its aid for the purpose of shortening editorial interviews at *Truth* office.

**WM. H. BALL & Co.,**

MANUFACTURING JEWELERS,

Anderson Building, 12-14-16 John St., N. Y.

**B14**  
TRADE MARK

Our Specialty:

**Everything in  
Gold Bracelets.**

Curb Bracelets, Bangle Bracelets, Fancy Stone Bracelets, Baby Esther Bracelets, Bracelet Mountings.



# Stella Music Boxes

ARE UNEQUALED FOR

Sweetness,  
Harmony and  
Volume

of tone, and have smooth  
metallic tune sheets playing  
thousands of tunes.

**Why Not** handle a line of Music Boxes the sale of which you can control and **Make Money?**

WRITE FOR CATALOGUE AND TERMS.

**Jacot & Son,** 39 UNION SQUARE,  
NEW YORK.

**W. C. A. WESTPHAL,**  
WATCHMAKER,  
41 Maiden Lane, NEW YORK.  
Established 1892. Telephone, 3684 Cortlandt.  
Estimates, Repairing, Adjusting of Chronometers, all  
Complicated Watches and Fine Time Pieces.  
**DEMAGNETIZING.**  
Watches made Non-Magnetic.  
Fine Wheel and Pinion Cutting

## KETCHAM & McDOUGALL,

MANUFACTURERS OF

GOLD AND SILVER  
**THIMBLES**

ESTABLISHED 1832.



TRADE-MARK.

And the improved

Automatic Eye-Glass Reel.



Pat'd Nov. 30, '94

SEND FOR  
CATALOGUE C.

37 MAIDEN LANE, NEW YORK.

**CROUCH & FITZGERALD,**  
Jewelry Trunks  
and Cases,  
161  
Broadway,  
Bet. Cortlandt and  
Liberty Sts.  
688 B'way,  
723 6th Av.  
NEW YORK.



**JUNK-SHOP METHODS.** The time is not far distant when a jeweler will demand different methods than are now employed by some salesmen in disposing of their stock. How any jeweler with any reputation will allow an auctioneer to run in a lot of inferior goods and sell them on his reputation, using his store for a junk-shop to dispose of the auctioneer's goods, not his, is a hard problem to solve.  
**E. J. GREGORY, Jewelers' Auctioneer,**  
Jewelers' Building, Boston, Mass.



Absolutely Reliable Always  
**Remington**  
Typewriter

STANDS THE TEST OF CONSTANT SERVICE  
Wyckoff, Seamans & Benedict  
327 Broadway, New York

## AIKIN, LAMBERT & CO.,

MANUFACTURERS OF

FINE GOLD PENS, HOLDERS, PENCILS,  
TOOTH PICKS and NOVELTIES.

PAUL E. WIRT FOUNTAIN PENS, at new and lower prices . . .  
MERCANTILE FOUNTAIN PENS, guaranteed to give satisfaction.

Catalogues with terms and discounts furnished to the trade.

BRANCH, 103 STATE STREET, - - - CHICAGO.

19 MAIDEN LANE, NEW YORK.

## AIKIN-LAMBERT JEWELRY CO.,

IMPORTERS OF

**DIAMONDS.**

JOBBER IN

WATCHES, JEWELRY, CHAINS,  
NOVELTIES, ETC.

LATEST DESIGNS.

LOWEST PRICES.

# CHAS. F. WOOD & CO., DIAMONDS

1 MAIDEN LANE, NEW YORK.

IMPORTERS AND CUTTERS.

## DIAMONDS.

LARGE ASSORTMENTS.

DESIRABLE SIZES.

ATTRACTIVE PRICES.

**R., L. & M. FRIEDLANDER,**

30 MAIDEN LANE, N. Y.

97 HATTON GARDEN, LONDON.

## HALL CLOCKS,

*Mantel Clocks,*

*Traveling*

*Clocks,*

*Clock Sets,*

*Regulators,*

*Bronzes,*

*Vases, Ivory*

*Miniatures*

*and Art Goods.*

Fall Line Now Ready.



**Harris & Harrington,**

32 and 34 VESEY ST., NEW YORK.

Sole Agents to the Trade for J. J. Elliott & Co., London.

IMPORTERS AND CUTTERS OF **Diamonds** 65 Nassau St. NEW YORK.  
**Arnstein Bros. & Co.**

**DIAMONDS** and Cutters. **L. & M. KAHN & CO.** 172 Broadway, Cor. Maiden Lane, N. Y. **DIAMONDS**

**Silver Clocks**  
**and Photo Frames,**

**Gilt Regulators,**  
**Cut Glass,**

**Fine China**  
**and Porcelain.**

**LE BOUTILLIER & CO.**

18 East 17th St., New York.

**H. M. RICH & CO.,**  
**Jewelry - Auctioneers,**  
**7 and 9 Franklin St.,**  
**BOSTON, MASS.**

### HOROLOGICAL DEPARTMENT,

BRADLEY POLYTECHNIC INSTITUTE,

PEORIA, ILLINOIS.

Largest and best watch school in America. We teach Watch Work, Jewelry, Engraving, Clock Work, Optics. (Formerly Parsons' Horological Institute.) Catalogue Free.



FAIRCHILD & JOHNSON CO.

GOLD AND SILVER PENCILS,  
PENHOLDERS, &c.

Office and Factory,  
220 FOURTH AVENUE, N. Y.

## L. LELONG & BRO.,

Gold and Silver

Southwest Corner of

HALSEY and MARSHALL STREETS,

NEWARK, N. J.

**REFINERS,**  
**ASSAYERS and**  
**SWEEP SMELTERS.**

**Sweepings a Specialty.**



No. 1916. No. 1947. No. 1948.

Factory, 100 STEWART ST., PROVIDENCE, R. I.

**S. & B. LEDERER CO.**

A Full Line of Gold, Silver and Rolled-Plate Hearts in a Thousand Different Designs.

New York Office, 11 John St.

Chicago Office, 131 Wabash Ave.

ALBERT LORSCH.

TELEPHONE CALL, 746 CORTLANDT, N. Y.

ALFRED KROWER

## ALBERT LORSCH & Co.,

LORSCH BUILDING,  
37 & 39 MAIDEN LANE, N. Y.,

167 WEYBOSSET ST.,  
PROVIDENCE, R. I.

JUST RECEIVED, A LARGE SHIPMENT OF

# DIAMONDS IN ALL SIZES.

**PROV. STOCK CO.** HIGH GRADE ROLLED PLATE  
**Chains**  
BRACELETS, LORGNETTES.

**10K. GOLD**  
Scarf Pins, Brooches,  
Neck Chains, Lorgnettes,  
Bracelets.

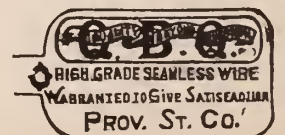

490 Stewart St., PROV., R. I. 11 John St., N. Y. Silver Smiths' Bldg., CHICAGO.



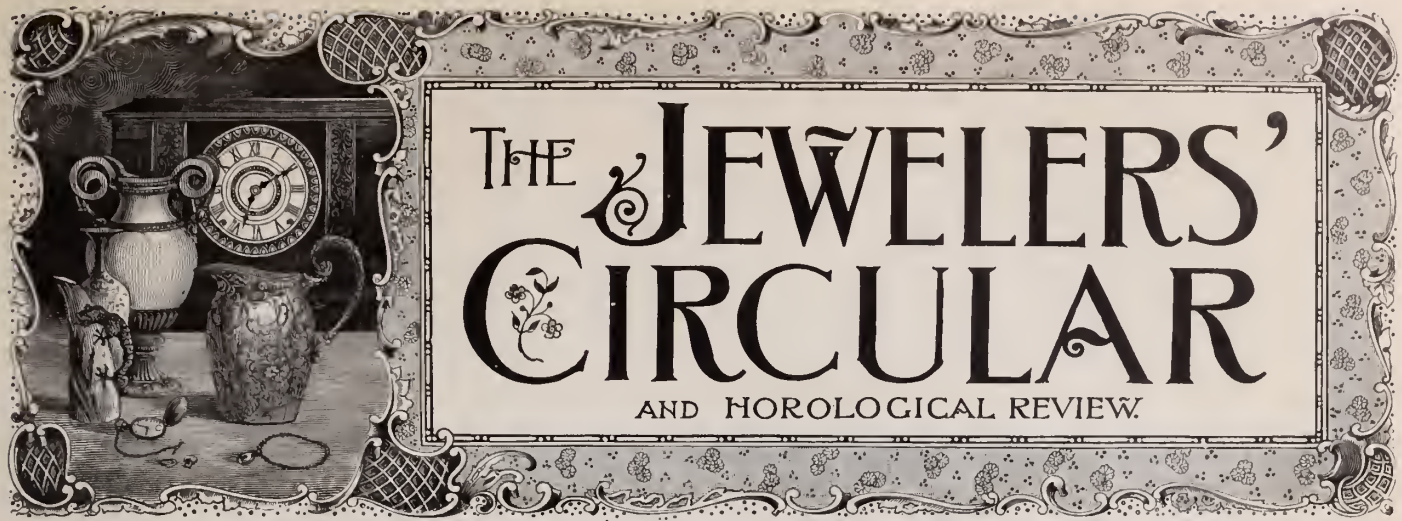

Corbin Building, 11 John St., Corner Broadway, New York.

Copyrighted by THE JEWELERS' CIRCULAR PUB. CO.

Entered at the Post Office in N. Y. as second-class matter.

VOL. XXXIX.

NEW YORK, WEDNESDAY, NOVEMBER 15, 1899.

No. 16.

## HOW DIAMONDS ARE MINED AT KIMBERLEY.

IN the exciting drama now being unfolded in South Africa no other incident attracts the attention of the world so strongly or raises such interesting mental pictures as the investment by the Boers of Kimberley, the modern Golconda, far richer in precious stones, in the people's imagination, than the mines seen by Sindbad. The mines within the city of Kimberley furnish 95 per cent of the world's diamonds, and in the mind's eye the community is a glittering fairyland—far different from the prosaic, rough and ready reality. The city and its mines have been for the past month a favorite theme of newspaper writers, and the romantic discovery of diamonds in the territory now known as Kimberley, the development of the mines, the amalgamation of the different mines, the enormous richness of and the great profits derived from them have been rehearsed and rehearsed until to-day there are few subjects upon which the public are as well informed or misinformed as the Kimberley diamond mines. But

are scenes in the city itself rather than of the mines. It is proposed in this article



FIG. 1. MINER AT WORK DRILLING ROCK BEFORE BLASTING.

as far as known, the only store house of diamonds in the original matrix in which they were formed by the enormously high temperature of volcanic action. At the present time the stones are found in what is termed "blue ground," though this is almost a solid rock. How hard this blue ground is may be seen from the picture showing a miner at work drilling rock before blasting (Fig. 1). The treatment of this rock in order to disclose the diamonds has been the principal problem to be solved. It was discovered that the mineral yielded to the solvent action of water, and to-day the system of mining may be summed up in a few words—washing out the earth and sifting. The apparatus has become more complicated and the operation more rapid, more thorough and less expensive when done on a large scale, but the principle is the same as that discovered by the old Boer who soaked his "blue ground," and waited till it disintegrated.

The DeBeers and Kimberley mines are



FIG. 2. TUNNEL WITH CART ACCUMULATING BLUE GROUND.



FIG. 3. CARTS HAULING BLUE GROUND TO THE FLOORS.

there is one aspect of the subject that has received little attention, and that is the manner in which the diamonds are mined and prepared for the London market; while such pictures as have been published

to give only, with the aid of a number of photographic views, a clear presentment of the various stages in the mining operations.

In the Kimberley mines the world has,

probably the two biggest holes which man has ever dug into the earth, the area of the former at the surface being over 13 acres, with a depth of over 500 feet; the area and depth of the latter being even



ILLUSTRATION 1/8 SIZE.

**JEFFERSON PATTERN.**

- |                                |   |                                    |                               |
|--------------------------------|---|------------------------------------|-------------------------------|
| 1307 Coffee (6 half pints).    | 908 Large Cloth Brush.                  | 1153 Cigar Jar (Victoria pattern). | 1382 Cut Glass Pungent.       |
| 1306 Large Tea (5 half pints). | 912 Large Bonnet Brush.                 | 983 Small Puff Box.                | 922 Shoe Hook.                |
| 1302 Small Tea (1 1/4 pints).  | 904 Large Mirror.                       | 976 Paste Box.                     | 927 Shoe Horn.                |
| 1304 Large Sugar.              | 1015 Whisk.                             | 1201 Cut Glass Bon Bon.            | 918 Nail File.                |
| 1301 Small Sugar.              | 996 Comb.                               | 1292 Cut Glass Candle Stick.       | 1281 Cut Glass Violet Holder. |
| 1303 Large Creamer (1 pint).   | 916 Nail Polisher.                      | 1157 Heart and Crown Coin Box.     | 1284 Cut Glass Crown Salts.   |
| 1300 Small Creamer (1/2 pint). | 888 Manicure Scissors.                  | 1378 Ink (American Beauty).        | 1385 Cut Glass Cologne.       |
| 1305 Spoon Holder.             | 893 Bankers' Shears.                    | 1285 Cut Glass Pungent.            | 1023 Pin Tray.                |
| 906 Large Hair Brush.          | 1145 Large Puff Box (Victoria pattern). | 1381 Cut Glass Pungent.            |                               |

Send for our small catalogue showing our latest productions in sterling silver goods, and do not fail to call for some of those beautiful little Brooches we have just brought out.

**THEODORE W. FOSTER & BRO. CO.,**

100 RICHMOND STREET, - - - PROVIDENCE, R. I.

**A USEFUL NOVELTY**

**Bottle Openers,**

in Sterling Silver and Silver Plate. The convenience and cleanliness of this form of bottling having brought it into general use, these Openers will be appreciated for the table. Send for catalogue.

MADE BY

**Goodnow & Jenks,**

**SILVERSMITHS,**

Stanhope and Morgan Sts.,  
Boston,

who have obtained the **SOLE RIGHT** from patentees to manufacture this article.



# The Best.

## The "DOUBLE-BASE" En-graving Block

shown upon this page is regarded by the users of the same as the best block for the price, viz.:

### \$15.00,

on the American market. The attachments, consisting of Spoon Holder, Button and Bangle Attachments, Ring Holder, Cement Plates, 8 sets (4 each) Pins and Pegs, and Leather Pad, are more than are given with any other block. It is a better finished block and more work can be done with the same than with any other block offered for sale.

### An Absolute Guarantee Is Given With Every Block.

In addition to the above attachments, we can furnish you with a Thimble Holder (2 pieces) for 50 cents; Cane and Watch-Cap Holder (4 pieces) for 75 cents; Cement Plates from 25 cents to 50 cents, and Polished Hardwood Base, with drawer and glass shade, for \$3.50.

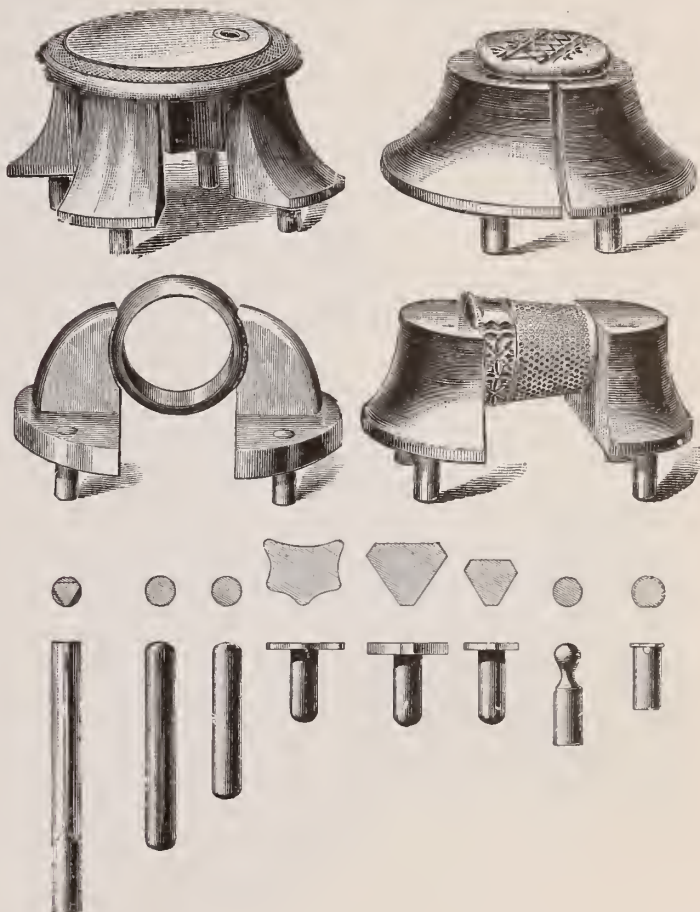
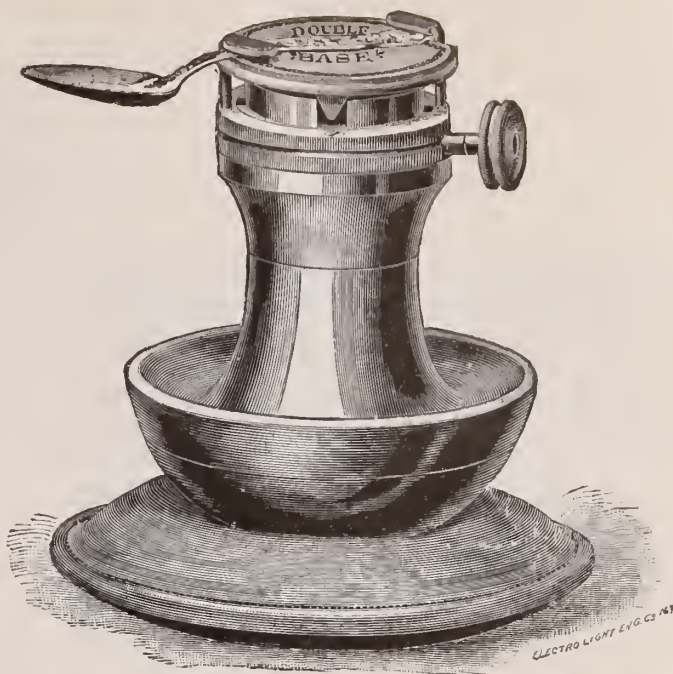

## L. C. REISNER & CO.,

Manufacturing Jobbers, Importers and Exporters,  
Watch Materials, Tools and Supplies,

Jewelry Repairers for the Trade.

LANCASTER, PA.

greater. These mines are no longer worked from the surface, but from shafts sunk at some distance from the original holes, and penetrating to the blue ground by transverse drivings at depths varying from 500 to 1,500 feet. The blue ground, when extracted, is carried in small iron trucks to the "floors." One of these trucks in one of the tunnels, accumulating

berley mine becomes quite well pulverized in three months, while that from DeBeers requires double that time. The longer the ground remains exposed the better it is for washing.

The process of exposure being completed, the blue ground is then carried to very large, elaborate and costly washing machines, in which, by means of the action

ent sizes, which then pass on to the assorters. The assorting is done on tables, first while wet by white men (Fig. 7), the only department employing white men, and then dry by natives (Fig. 8). A sign in the natives' sorting room reads: "Notice—Visitors must on no account speak to the convicts." These men are not strictly convicts, but, as they are bound for

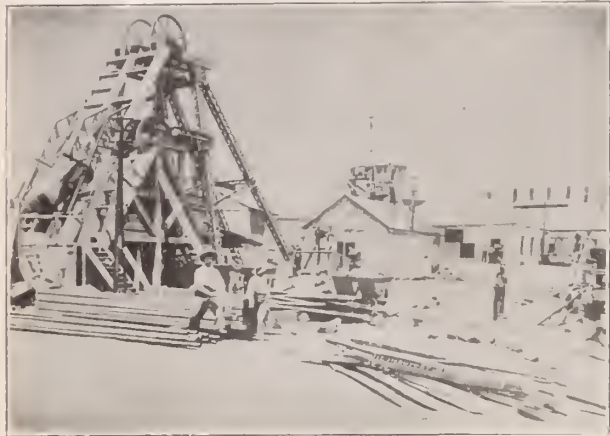

FIG. 4. MACHINERY FOR HAULING TRUCKS OF BLUE GROUND TO THE FLOORS.

blue ground, is illustrated on page 1 (Fig. 2). The "floors" are made by removing the bush and grass from a fairly level piece of ground; the land is then rolled and made as hard and as smooth as possible. These "floors" are about 600 acres in extent. They are covered to the depth of about a foot with the blue ground which, for a time, remains on them without much manipulation. The blue ground is transferred to these floors from the shafts by lines of trucks hauled, as shown in Figs.

of running water, the diamonds are separated from the ordinary earth. A view of this washing gear is given in Fig. 5, where is shown the separation of the sand and earth from the solid materials. This machinery is of American make, and is run entirely by American engineers. In fact all the mining engineers of the Kimberley mines are Americans. It may be mentioned that in this process 100 loads of blue ground are concentrated into one load of diamondiferous stuff. In washing

2 years' service and are not permitted outside the compounds, they are essentially prisoners. The assorters work with a kind of trowel, and their accuracy in detecting and separating the diamond from the eight different kinds of mineral formations which reach them is almost unerring.

After assorting the diamonds are sent daily to the general office under an armed escort, and delivered to the valuers in charge of the diamond department. The first operation is to clean the diamonds of

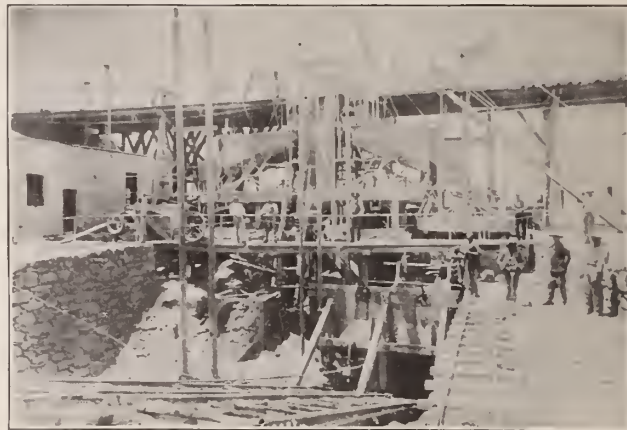

FIG. 5. WASHING MACHINE (FRONT VIEW) SEPARATING SAND AND EARTH FROM SOLID MATERIAL.

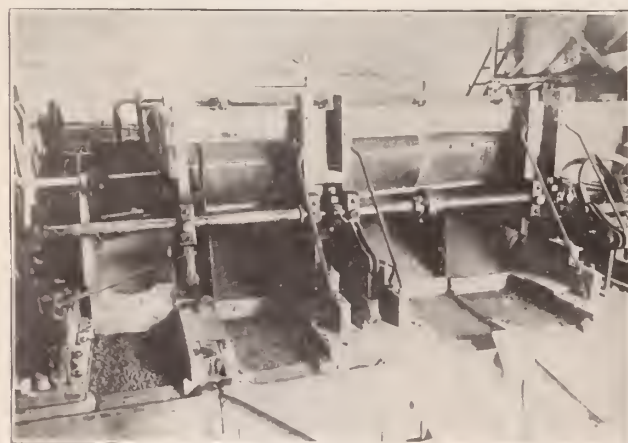

FIG. 6. THE PULSATOR SORTING DIAMONDIFEROUS STUFF INTO FOUR SIZES.

3 and 4. The heat of the sun and moisture soon have a wonderful effect upon it. Large pieces which were as hard as ordinary sandstone when taken from the mine, soon commence to crumble. At this stage of the work the winning of the diamonds assumes more the nature of farming than of mining; the ground is continually harrowed to assist pulverization by exposing the larger pieces to the action of the sun and rain. The blue ground from Kim-

berley the greatest care, of course, has to be exercised to guard against washing away diamonds. Not only is this prevented, though not invariably, by every mechanical means, but this part of the work, like every other, is constantly watched by responsible overseers. Another machine, the pulsator (Fig. 6), then separates the diamondiferous stuff, which appears to be a mass of blue and dark pebbles of all shapes, into four differ-

ent sizes, which then pass on to the assorters. The assorting is done on tables, first while wet by white men (Fig. 7), the only department employing white men, and then dry by natives (Fig. 8). A sign in the natives' sorting room reads: "Notice—Visitors must on no account speak to the convicts." These men are not strictly convicts, but, as they are bound for



FIG. 7. ASSORTERS (WHITES) DOING THE FIRST ASSORTING FROM THE GRAVEL.

STERLING SILVER....

**CHATELAINE BAG**

....in....

ANTIQUE FLEMISH FINISH.

Price, Seal or Velvet,

**\$17.50 NET.**

SPECIAL VALUE....

AND VERY CHOICE.



No. 2085,  $\frac{2}{3}$  scale.

**DEITSCH BROS.,**

14 EAST 17TH ST.,

NEW YORK.



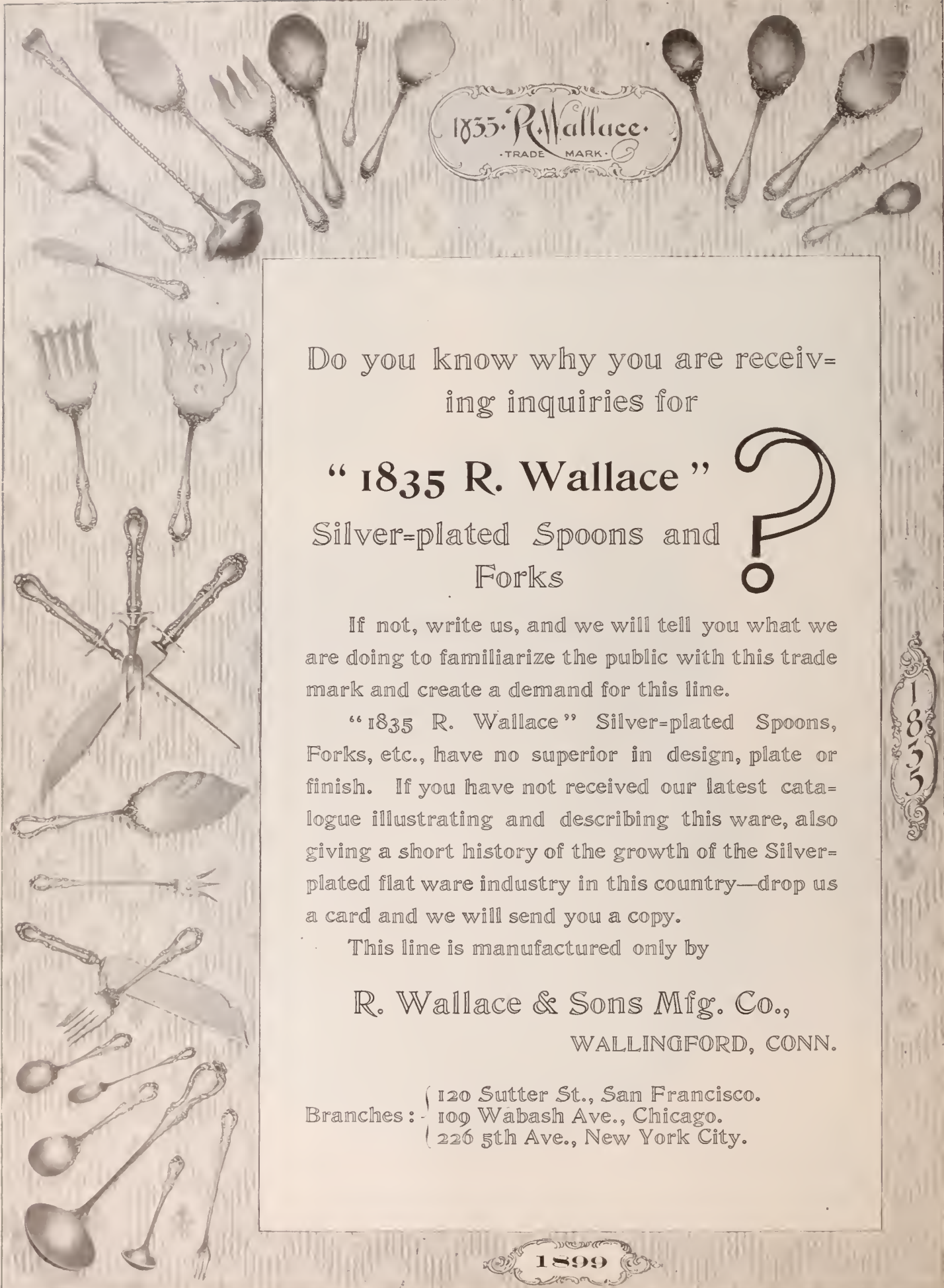

Do you know why you are receiving inquiries for

**“ 1835 R. Wallace ”**

Silver-plated Spoons and Forks

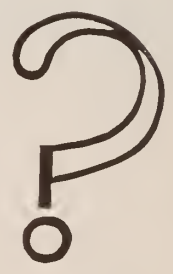

If not, write us, and we will tell you what we are doing to familiarize the public with this trade mark and create a demand for this line.

“1835 R. Wallace” Silver-plated Spoons, Forks, etc., have no superior in design, plate or finish. If you have not received our latest catalogue illustrating and describing this ware, also giving a short history of the growth of the Silver-plated flat ware industry in this country—drop us a card and we will send you a copy.

This line is manufactured only by

**R. Wallace & Sons Mfg. Co.,**  
WALLINGFORD, CONN.

Branches: ( 120 Sutter St., San Francisco.  
109 Wabash Ave., Chicago.  
226 5th Ave., New York City.

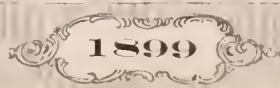
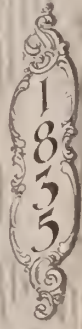

variety. In this room are concentrated some 60,000 karats, the daily production of the Consolidated Mine being about 5,500 karats.

In the working of the mine there are employed about 1,300 Europeans and 5,700 natives. The wages paid range high. Mechanics and engine drivers receive from £6 to £7 per week; miners from £5 to £6; guards and tally men from £4 to £5; natives in the underground works are paid from 4s. to 5s. per day. In the work on the "floors," which is all surface work, overseers receive from £3 12s. to £4 2s., machine men and assorters from £5 to £6, and ordinary native laborers from 17s. 6d. to 21s. per week. In addition, every employe on the "floor" has a percentage on the value of the diamonds found by himself, the white employes receiving 1s. 6d. and the natives 3d. per karat. Nearly double these amounts are paid for stones found in the mines.

The company sustain a considerable though decreasing loss by diamonds being stolen from the mines. To check this loss extraordinary precautions have been resorted to. The natives are engaged for a period of three months, during which time they are confined in a compound surrounded by a high wall. On returning from their day's work they have to strip off all their clothes, which they hang on pegs in a shed. Stark naked they then proceed to the searching room, where their mouths, their hair, their toes, their armpits and every portion of their bodies are subjected

to an elaborate examination. White men would never submit to such a process, but the native sustains the indignity with cheerful equanimity, considering only the high wages which he earns. After passing through the searching room they pass, still in a state of nudity, to their apartments in the compound, where they find blankets in which to wrap themselves for the night. During the evening the clothes which they had left behind them are carefully and minutely searched, and are restored to their owners in the morning.

Before 1887, falls of reef were a not uncommon occurrence. Since the consoli-

dated, however, in 1887, measures have been taken to prevent such disastrous occurrences, and, though rumors of falls from time to time arise, there have been no authenticated accidents of this sort in recent years. The effect of such a fall is shown in the illustration, Fig 10.

The engravings in this article are made from a valuable collection of photographs in the possession of Ludwig Nissen, of



FIG. 8. ASSORTERS (NATIVES) SORTING FOR POSSIBLE OVERSIGHTS BY FIRST ASSORTERS.

Ludwig Nissen & Co., 18 John St., New York, who has devoted much time and attention to a study of the diamond mines and the diamond industry.

#### Death of Thomas K. Brunner.

CIRCLEVILLE, O., Nov. 8.—Thomas K. Brunner, one of the oldest and best known

#### Mail Thieves Caught Red Handed in Halifax, N. S.

HALIFAX, N. S., Nov. 6.—For the past five or six weeks reports have reached the post office inspector at Halifax of parcels of merchandise being missing from the mails, the missing parcels, as a rule, being those containing jewelry, silver knives, forks, &c. In all some 20 cases were reported. These reports, followed up, proved to refer to articles sent from the eastern part of the province of Nova Scotia to parties in the western portion. Saturday night last the detective, who had been detailed on the case and had been at work on it for nearly two weeks, was on the point of giving it up, when he got a clue and caught the robbers "red-handed." It appears that the mail sacks containing newspapers and parcels which arrived at Halifax from the eastern part of the province at night were allowed to remain on a truck in the railway station till the train left for the west next morning, the only one in charge during that time being a night watchman. The bags were tied but not sealed. Saturday night the suspicions of the detective were aroused by the conduct of two young men who were hanging about the station.

They appeared to be assisting the mail driver in transferring the bags from the cars. After quite a wait he pounced upon them in the act of untying the bags, and managed to arrest one, the other escaping. The one arrested, named Pender, gave his pal away, and he was captured next day;



FIG. 9. MINERS AT PLAY IN THE COMPOUND.



FIG. 10. PART OF MINE AFTER A BIG FALL OF REEF.

to an elaborate examination. White men would never submit to such a process, but the native sustains the indignity with cheerful equanimity, considering only the high wages which he earns. After passing through the searching room they pass, still in a state of nudity, to their apartments in the compound, where they find blankets in which to wrap themselves for the night. During the evening the clothes which they had left behind them are carefully and minutely searched, and are restored to their owners in the morning.

Before 1887, falls of reef were a not uncommon occurrence. Since the consoli-

dated, however, in 1887, measures have been taken to prevent such disastrous occurrences, and, though rumors of falls from time to time arise, there have been no authenticated accidents of this sort in recent years. The effect of such a fall is shown in the illustration, Fig 10.

The engravings in this article are made from a valuable collection of photographs in the possession of Ludwig Nissen, of

his name is West. Pender was searched at the police station, and two watches, sleeve links, chains, a broken watch movement and a large number of small articles were found upon him. His boarding place was then searched, and a great variety of articles recovered, including a silver watch, studs, several gold and silver chains, silver knives and forks, spectacles, kid gloves, spoons, &c.

A fire started in the Towsley House, Waterloo, N. Y., Nov. 10, spread to several stores, the jewelry store of George E. Sherwood suffering considerably.



"Watch Our Ads."

Prices on  
Application.

**The Mauser Manufacturing Co.,**  
...SILVERSMITHS...

15th Street, between Broadway and 5th Avenue, NEW YORK.



Bonbon Dish,  
No. 2142.

*"Sterling Silver Goods Only."*

This is only one of our new  
**BONBON DISHES**



TRADE-MARK.

**FRANK M. WHITING  
& CO.,**

**Silversmiths,**

**NORTH ATTLEBORO, MASS.**

1128 Broadway, New York.  
220 Sutter St., San Francisco.

Complete line of Samples always on display  
at our New York Office.

Our line of Dishes, Trays, Bowls,  
Tea Sets, Loving Cups, Toilet  
Goods, etc., is very complete  
this season.



**Testimony in an Important Trade Name Suit.**

It may be remembered by readers of THE CIRCULAR that shortly after the Camm-Roy Watch Case Co., 21 Maiden Lane, New York, were incorporated under that name, an action was commenced by the Roy Watch Case Co., of the same address, to restrain the former concern from using their corporate name. The Camm-Roy Watch Case Co. were the successors of the Roy Mfg. Co., and the name was changed after F. L. Camm had associated himself with that concern.

When the action was commenced a motion was made before Judge Gildersleeve, in the New York Supreme Court, for a preliminary injunction restraining, during the pendency of the suit, the Camm-Roy Watch Case Co. from using his name, and this motion was finally granted in an opinion which has already been published in THE CIRCULAR.

The action came up for trial Wednesday before Judge Werner, in Part IV., Special Term of the Supreme Court, and lasted until Thursday afternoon. The complainants put upon the stand but one witness, Charles Glatz, and in rebuttal introduced the testimony of A. L. Brown, while the witnesses for the defendants were W. I. Rosenfeld and a Mr. Kahn, jobbers in watches, and Wm. F. MacDonough, F. L. Camm and A. X. Roy, members of the defendant company. The testimony brought out the fact that both the concerns got the name Roy in their title from A. X. Roy, now president of the defendant company, who was one of the incorporators of the Roy Watch Case Co. and one of the stockholders of the company until 1889. He then left the concern, starting in business as Roy & Co., subsequently incorporating it as the Roy Mfg. Co. and finally changing it to the Camm-Roy Watch Case Co. It is now known as the Camm-Roy Watch Case Co.

The testimony for the plaintiffs was to the effect that the similarity of names embarrassed their business and caused confusion and mistake. It also reduced the

plaintiffs' sales and deceived the public, and they contended that the use of the name. Camm-Roy Watch Case Co., was intended to confound the identity of the two businesses and induce persons to deal with the defendants in the belief that they were dealing with the Roy Watch Case Co.

The directors of the defendant company all testified that they had no intention of causing confusion when they adopted their corporate name, but had done it with the sole purpose of putting Mr. Camm's name in their title, as he had been so long in the watch business that it would benefit them thereby. By using the word, Camm-Roy, they thought there would be even less confusion than there formerly was between the Roy Mfg. Co. and the plaintiffs' name. Testimony was also introduced to the effect that there were about 200 jobbers, and that all these knew the difference between the concerns, and that, therefore, there could be no confusion; that the defendant company had made it plain to the trade they were the successors of the Roy Mfg. Co.; that retailers usually purchased their goods by sizes and styles, and not as the product of particular manufacturers, and that the public at large did not know or care anything as to the manufacturer of watch cases. After the testimony had been finished, Judge Werner gave counsel until Nov. 18 to submit briefs, and reserved decision.

**Leffingwell's Turquoise Syndicate Incorporated Under New Jersey Laws.**

The North American Turquoise Syndicate, which, as recently published in THE CIRCULAR, were promoted by A. MacGregor Leffingwell, of New Haven, Conn., for the purpose of consolidating a number of New Mexico turquoise mines, were incorporated under the laws of New Jersey, last week, with a capital of \$1,000,000. Their principal office is given as 243 Washington St., Jersey City, N. J., and their objects are to mine and deal in precious stones.

A. MacGregor Leffingwell, Douglas Leffingwell and Thomas J. Madden are the incorporators of the company.

**Importations at the Port of New York.**

*Weeks ended Nov. 11, 1898, and Nov. 10, 1899.*

China, Glass and Earthen Ware:	1898.	1899.
China .....	\$96,457	\$57,515
Earthen ware .....	16,332	14,110
Glass ware .....	19,082	13,498
Instruments:		
Musical .....	9,253	8,534
Optical .....	9,257	8,492
Philosophical .....	1,286	4,312
Jewelry, etc.:		
Jewelry .....	5,748	7,287
Precious stones .....	196,029	204,802
Watches .....	18,815	27,199
Metals, etc.:		
Bronzes .....	1,425	5,874
Cutlery .....	21,879	11,910
Dutch metal .....	4,175	.....
Platina .....	10,714	30,160
Plated ware .....	537	.....
Silver ware .....	2,404	803
Miscellaneous:		
Alabaster ornaments .....	3	\$11
Amber .....	4	4,582
Beads .....	238	1,215
Clocks .....	4,846	6,348
Fans .....	9,163	1,226
Fancy goods .....	3,510	8,777
Ivory .....	16,712	1,621
Ivory, manufactures of.....	1,657	197
Marble, manufactures of.....	10,635	13,616
Statuary .....	3,233	4,847

**The Case Against A. F. Pickert Falls to the Ground.**

ATLANTA, Ga., Nov. 8.—A. F. Pickert, jeweler, was placed on trial Monday morning before Judge John S. Candler in the Superior Court on the charge of receiving stolen goods. The prosecution failed to make out a case, and, by direction of Judge Candler, the jury returned a verdict of not guilty. It was not even necessary for the defense to introduce any testimony.

The prosecution first broke down on the testimony of Will Etheredge, who had confessed that he burglarized the house of S. W. Wilkes. Etheredge testified that he was employed by Pickert in the commission of the crime, but upon cross-examination he was made to contradict himself repeatedly, and in other ways to cast discredit upon his testimony. The evidence against the defendant was of such a nature that Attorney Rosser, for

**THE APOLLO** 

WARRANTS THE EPITHET "POPULAR,"  
as shown by sales from Maine to Oregon.



Made by **J. B. & S. M. KNOWLES CO.,**  
PROVIDENCE, R. I.

Established 1852.

**STERLING SILVER ONLY.**



TRADE MARK

the defense, made a motion that the jury be instructed to return a verdict of not guilty. This motion was argued at some length, but was finally concurred in by Judge Candler. The trial was thus brought to an abrupt end and the defendant declared acquitted.

#### Proceedings of the Optical Society of the City of New York.

The regular monthly meeting of the Optical Society of the City of New York was held, as usual, Wednesday evening, in Parlor D R of the Fifth Avenue Hotel. The scientific session began at 8.30 o'clock with a lecture by Prof. Fox on "Geometrical Study of Curved Mirrors," in which he took up especially the theory of circular mirrors. Then followed a practical lecture by L. L. Ferguson on "Indirect Ophthalmoscopy," after which the business session began.

Among the first business to come before the meeting was the report of the committee appointed to consider the question of identifying the city optical society with the State society. Chairman M. H. Harris, of this committee, was called upon and read the following report:

"The committee appointed by the president to consider the merging of the Optical Society of the City of New York into the N. Y. State Optical Society met at the office of the chairman of the committee on Nov. 2, '99. Mr. L. L. Ferguson attended as an honored guest. After an extremely interesting discussion the committee unanimously voted in favor of consolidation."

This report was then taken up by the society and, after being discussed, its acceptance was moved by A. Jay Cross and the motion carried.

Among the applications for membership were the following, which were left to take the usual course of procedure: R. A. Brunner, Rutherford, N. J.; F. C. Bates, New York, and W. Ivison, New York. The following new members were elected: Daniel Rosche, Denver, Col.; Chas. D. Mueller,

Newport, R. I.; Richard Stroubel, New York; H. Vallient, New York, and Mrs. Bosrer, New York.

#### The Rochester Optical Club Hold an Interesting Meeting.

ROCHESTER, N. Y., Nov. 7.—A meeting of the Rochester Optical Club was held on the night of Nov. 3 in the office of B. B. Clark, Triangle building. The reports of the officials showed that the association were in a prosperous condition. A committee were appointed to found a circulating library, to include works by the leading authors and opticians. The club voted to become a member of the Optical Society of the State of New York. A prospectus for the meetings of the next six months is being made out, and will include several papers each evening by members and outsiders, and other entertainment is being prepared for the meetings of the next six months.

#### Mrs. J. L. Bliss Has Another Legacy Added to Her Wealth.

ATCHISON, Kan., Nov. 9.—Mrs. J. L. Bliss and her daughter, Miss Grace Bliss, and Mrs. Bliss's sister, Mrs. Nellie Dunham, all prominent in Atchison society and already wealthy in their own names, have inherited a large fortune in New England by the death of Benjamin Pierce, of Spoford, N. H., father of Mrs. Dunham and Mrs. Bliss. Mrs. Bliss's and Mrs. Dunham's share is about \$150,000 each. Each receives \$100,000 in Government bonds, drawing interest at the rate of 4 per cent, and property in Kansas City, St. Louis and New England. Miss Grace Bliss's share in the estate is about \$100,000.

Mrs. Bliss inherited \$100,000 by the death of her husband four years ago. J. L. Bliss was a Grand Army man, known widely over Kansas. He was proprietor

of a large jewelry store in Atchison, and since his death his widow has successfully conducted the business.

#### Sory, Brown & Co.'s Store Burglarized of Considerable Goods.

JACKSONVILLE, Tex., Nov. 8.—Sory, Brown & Co.'s jewelry store was burglarized here a few nights ago. The following is the list of goods stolen: One solid gold bracelet, with set in center of chain on lock, patent applied for; one sterling silver solid wire chain bracelet, H. F. B. & Co. make; two gold plate solid wire bracelets, H. & H. make; two 14-karat gold filled chain bracelets, Y. & S. make; three 14-karat gold filled chain bracelets, five plain gold filled rings, three gold filled brooch pins with sets, one solid gold heart, one gold filled 15-year chain, double breasted; three gold filled ladies' neck chain guards, two pairs cuff buttons, four French harps, six New England nickel watches, six gold plated girls' chain bracelets. Liberal reward will be paid for arrest and conviction of guilty party or parties and for return of stolen goods. John B. Reagan, sheriff Cherokee county.

#### Medical Examiners for the Jewelers' League.

The following physicians were recently appointed medical examiners for the Jewelers' League: Dr. C. H. Harbaugh, 225 S. 16th St., Philadelphia, Pa.; Dr. J. T. Little, 535 Smithfield St., Pittsburgh, Pa.; Dr. L. B. Clarke, Atlanta, Ga.

The Palamountain Co., of Charlotte, N. C., have incorporated. The incorporators are Etta R. Palamountain, B. A. Sutherland and George N. Adams. The business of the corporation is to deal in jewelry and optical goods and the capital stock is \$5,000.



H L

We Manufacture  
Knives, Forks, Spoons and Cutlery.  
Hollow Ware, Toilet Ware and Manicure Pieces.

The Kind that is sought in Jewelry Stores  
Not found elsewhere.

HOWARD STERLING CO.  
Silversmiths.  
Providence - New York - San Francisco.

# A. WITTNAUER,

MANUFACTURER OF

## THE CELEBRATED

# Longines and Agassiz Watches,



9-11-13  
MAIDEN LANE,  
NEW YORK.



AGASSIZ MOVEMENT  
1899 MODEL.

WHICH HAVE BEEN  
SOLD TO THE LEAD-  
ING JEWELERS OF  
THE WORLD DUR-  
ING THE PAST

## 53 YEARS.

WE HAVE A COMPLETE VARIETY OF



CASE  
1899 MODEL.

## Decorated Watches for the Holiday Trade.

9-11-13 Maiden Lane,      New York.

Geneva Office, 16 Rue du Mont Blanc.

**The New Customs Tariff of Rhodesia, South Africa.**

WASHINGTON, D. C., Nov. 11.—Consul-General Stowe writes from Cape Town, Sept. 23, 1899:

A new customs tariff came into force throughout Rhodesia on the 1st of August. It is almost the same as the South African Customs Union tariff. Fifteen per cent of the receipts will be retained by Cape Colony for collecting the duties at its sea-ports. Considerable objection is made on account of its retrospective effect on stocks existing January 1, 1899. The duties imposed are:

**CLASS I.—SPECIAL RATES.**

Beads, known as "Kaffir beads," per pound, 3d = 6 cents.

**CLASS III.—AD VALOREM 7½ PER CENT.**

The following articles shall be liable to a duty of 7½ per cent ad valorem:

Articles of wearing apparel and personal adornment, including both shoes and slippers (exclusive of blankets, sheets, rugs, etc.)

Jewelry, plate, clocks, watches.

None of these duties shall extend or apply to any articles ground, produced, or manufactured within the South African Customs Union, or to any articles described in the free list, attached to the said customs union tariff.

**CUSTOMS UNION FREE LIST.**

Church decorations, altars, bells, fonts, lecterns, pulpits, organs, plate or vestments and illuminated windows imported by or for presentation to any religious body.

Cups, medals and other trophies imported for presentation or presented as prizes at examinations, exhibitions, shows or other public competitions for excellence in art, bravery, good conduct, humanity, industry, invention, manufactures, learning, science, skill or sport, or for honorable or meritorious public services; provided that such articles shall on importation or delivery free from the customs bear engraved or otherwise indelibly marked on them the name of the presenter

or presentee, and the occasion or purpose for which presented.

**TRANSIT TARIFF TO RHODESIA.  
No Rebate.**

Beads, known as "Kaffir beads."

Articles of wearing apparel and personal adornment, including boots, shoes and slippers.  
Jewelry, plate, clocks and watches.

**Plans of the Providence Working Jewelers' Organization.**

PROVIDENCE, R. I., Nov. 11.—The newly formed organization of the working jewelers is preparing to hold a mass meeting in the near future, probably within two weeks. At a meeting of the Journey-men Jewelers' Protective Association, No. 7,607, A. F. of L., held in Music Hall building, this decision was arrived at. This was the first meeting at which the regular work of the organization was conducted. Among other items of business transacted was the election of 60 new members, making about 475 names on the rolls. It was stated that the object of the public meeting would be to place squarely before the working jewelers and their employers, as well as the general public, the position of the association, its aims and what it expects to accomplish. Speakers from this city and from New York will be relied upon to make the explanation.

E. A. Doyle, retailer, Munroe St., Lynn, Mass., has been compelled by increasing business to remove to a larger store on the same thoroughfare, his new location being nearly opposite the old one.

**Tariff Decisions & Regulations.**

**REFUND DUTIES.**

WASHINGTON, D. C., Nov. 7.—Section 1 of the Customs Administrative Act of June 10, 1890, provides that "all merchandise imported into the United States shall, for the purpose of this act, be held and deemed to be the property of the person to whom the merchandise may be consigned." In view of this provision of the law the Treasury Department has instructed collectors of customs to the effect that certified statements for refund of duties should, in all cases, be made out in the name of the person to whom the merchandise was consigned and who paid the duties thereon.

**Resolutions on the Death of Moses Bruhl.**

At a recent meeting of the officers of the Ladies' Sewing Society of the Hebrew Orphan Asylum, of New York, the following resolutions on the death of Moses Bruhl were unanimously adopted:

Whereas, It has pleased the Almighty to call to his rest our lamented friend, Moses Bruhl, through whose death this society has lost one of its kindest benefactors; one who, by his munificent endowment of the Betty Bruhl Prize Fund, has given to our orphans a constant incentive to high endeavor and has provided for them some of the brightest days of their lives; be it

Resolved, That we express our deep sense of the benefits he has conferred on the children of our orphanage, in whose hearts his memory will ever be perpetuated.

Resolved, That these resolutions be spread on the minutes of this society, and that a copy thereof, suitably engrossed, be presented to the family of the deceased.

Mrs. J. BOOKMAN, President.  
Mrs. L. LAVENBERG, Hon. Secretary.

**Henry Rehmke & Bro.'s Store Robbed of a Large Quantity of Goods.**

ELLENSBURG, Wash., Nov. 6.—While the proprietors were absent at dinner, Nov. 1, the jewelry store of Henry Rehmke & Bro., 4th St., this city, was entered by a burglar, who helped himself to most of the valuables contained in the show cases. The thief secured a costly and excellent selection, consisting of 32 solid gold watches, eight high-grade movements, 46 diamond rings, about 400 other rings; also several fine brooches, lockets, charms, earrings, cuff buttons and pins.

The burglar has been caught and most of the jewelry recovered. About \$500 worth of valuables is still missing.

**Kruger's Talismanic Watch Charm.**

THE Cape Town correspondent of a London paper says that of the sum of 12 shillings 6 pence, which was the total amount in the Boer Treasury at the time of the gold find on the Rand, President Kruger thoughtfully appropriated the only gold coin, with the remark, "The last of the old gold and the old luck." He has since worn the coin as a charm upon his watch chain, and is said to have regarded it with a feeling of almost superstitious veneration. Some two months ago, however, it became accidentally detached, and all efforts to find it have been in vain. The President has been inconsolable for the loss, regarding it as an omen of disaster.

**WHO SAID WATCHES?**

Ladies' Watches,  
Gentlemen's Watches,  
**Railroad Watches.**

We Are the Largest Distributors of  
**Dueber-Hampden Watches**  
IN NEW YORK.



*John N. Sherwood & Co.*  
Watches. Chains. Diamonds. Jewelry.

No. 3 MAIDEN LANE, NEW YORK.

# THE DUEBER HERALD

THE ADVOCATE OF HONEST BUSINESS METHODS.  
✻ DEVOTED TO THE RETAIL JEWELRY TRADE. ✻

Vol. I.

CANTON, OHIO, NOVEMBER, 1899.

No. 8

## SIMPLE ARITHMETIC.

Put one and one together.

\* \* \*

Take Honesty of Purpose; add honest, thorough-going Ability.

\* \* \*

Subtract "Rainbow Chasing;" multiply by Success, and the result is: The Perfect Product.

\* \* \*

The Dueber-Hampden watch represents honesty of purpose, honest, thorough-going ability, religious avoidance of "rainbow chasing"; it represents: Success!

\* \* \*

Therefore, the Dueber-Hampden watch is the perfect product, the perfect watch, "The Best." Its every tick, as Time wears on, marks more and more the triumph of Honesty, Ability and Truth.

Palestine, Texas.

I am proud to be the possessor of a Dueber-Hampden watch in a gold Dueber case. In my estimation, a railroad man who is subjected to such continual jostling and changes of temperature and atmosphere, there is no watch which can beat it. I have been 14,000 feet above sea level in Colorado, 260 feet below sea level in the desert of California, under the tropical sun of Mexico, and my Dueber-Hampden never failed me.

GEO. H. WESTERVELT.

## THE QUESTION OF POLICY.

Sweet smiles and honeyed words play their part in business, as they do in the rest of the world's affairs.

*The Dueber Herald* does not admire sweet smiles and honeyed words. *The Herald* believes in a "straight-out-from-the-shoulder" policy.

The merchant who makes Reliability his watchword, who studies the why and wherefore of the goods he sells that he may be sure of his ground, needs no unctuous demeanor, no bowing and scraping to make and hold trade.

The dealer who is sure of his ground, who sells an article that he can stand by—and knows it—may safely cultivate a reasonably independent attitude. Then his words will carry a conviction that the honey-eyed kind do not.

Let those who differ, try.

Dueber goods sell on their merit Study the question and you will be sure of your ground



Entrance to Office, Hampden Watch Works.

## AGAIN THE STAMP.

Honest money ought to buy honest goods.

\* \* \*

Honest goods ought to be honestly stamped.

\* \* \*

A misleading, dishonest stamp on a watch case, is like a misleading, dishonest stamp on a piece of silver.

\* \* \*

Is it, therefore, not of vital importance to you and to every honest jeweler in the country that dishonestly stamped watch cases be driven out of the market?

\* \* \*

Answer the question to yourself; then act.

\* \* \*

## DUEBER WATCH CASES

ARE

First in Weight,  
First in Style,  
And first in the hearts of those who know.

**A. & B.**  
**HEADQUARTERS**  
 FOR  
**Waltham Watches**  
 EVERY GRADE.  
**AVERY & BROWN,**  
 68 Nassau St., New York.

**CASH OFFERS.**

If at any time you have offered to you by your customers any Jewelry containing diamonds, pearls or other precious stones, and you do not care to buy them yourself, send them to us and we will submit an IMMEDIATE CASH OFFER. Trade and Bank References if desired. Established 1880. Correspondence solicited.

CHARLES S. CROSSMAN & CO.,  
 3 Maiden Lane, New York.

DON'T FORGET THE JEWELERS' CIRCULAR PUBLISHING CO.'S BOOK LIST when in want of any technical work in the Jewelry or Kindred Trades.

**Sudden Death of O. R. Ryan.**

CHICAGO, Ill., Nov. 11.—The sad news was telegraphed here Friday evening that O. R. Ryan, one of the most popular traveling men in the west and representing the Towle Mfg. Co., this city, had died suddenly at the Athearn hotel, in Oshkosh, Wis. While eating a lozenge it slipped into his windpipe and he died in a few minutes from suffocation. Mr. Ryan had been western and northwestern traveler for the Towle Mfg. Co. for 10 years past and all who knew him liked him. He was a remarkably successful salesman, due in large measure to his indefatigable energy. For his probity of character he had endeared himself to his many customers, who relied upon his word and judgment to an unusual extent. The knowledge that "Whatever Ryan says is so" was another reason for his success.

Mr. Ryan was the senior partner in the jewelry firm of Ryan & Barnhart, Reedsburg, Wis., and has an uncle, C. E. Ryan, in business at Baraboo, Wis. He was also related by marriage to A. L. Haman, St. Paul, Minn. Deceased was a man of fine principles and politically was a staunch Republican and much sought after as a campaign speaker. He took great interest in the money question, in which he was well posted, and was a wide reader and a student. He was held in the highest esteem by his employers, both as a business and personal friend. Mr. Ryan leaves a wife and one daughter, aged 17 years, who has graduated from the State University at Madison.

Mr. Todd, of the Towle Mfg. Co., left for Oshkosh immediately on receipt of the

telegram, to make such arrangements as the family might desire.

**Death of Augustus Claus.**

SPRINGFIELD, Ill., Nov. 13.—The death of Augustus Claus, a long established jeweler of this city, occurred on Friday. Mr. Claus had been in the jewelry business here for more than 20 years. He failed a number of years ago, but recovered his losses and for years has been well regarded.

**Death of a One Time Well Known Philadelphia Jeweler.**

PHILADELPHIA, Pa., Nov. 11.—Albert Moore, at one time head purchaser for the old jewelry firm of Robins & Bailey, now Bailey, Banks & Biddle Co., and who was well known to the trade all over the country, died to-day at the age of 62 years, at his residence, in Church Lane, Yeadon, Delaware county, after an illness of four weeks' duration. For the last 12 years Mr. Moore was connected with the Lehigh Valley Railroad Co. He leaves a widow and two daughters.

The John Larson jewelry store, corner of Main and Pinckney Sts., Madison, Wis., has been sold by N. B. Van Slyke to F. P. D'Arcy, of Kalamazoo, Mich., for \$10,000. John Larson and the present help will be retained by the new owner. The stand has been used as a jewelry store since 1855. Mr. D'Arcy will remodel and re-stock the store and run it in addition to his stores in Zanesville, O., and Kalamazoo, Mich.

**"OMEGA" WATCHES.**

**NONE BETTER MADE. OVER 1,000,000 IN USE.**

We want ALL LEADING Jewelers to know that the "OMEGAS" are the best watches for you to handle.

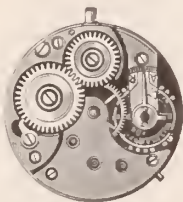

FINE ANCHOR MOVEMENT, 10 LIGNE, FULL JEWELLED - FITTED IN 14 AND 18K. O. F. CASES, SMOOTH AND FANCY ENAMELED CASES. GOOD SELLERS FOR FINE TRADE.

SEND FOR PRICE-LIST.



Pendant Set. 12, 14 and 16 Size. Made in Gun Metal, Silver, Gold Filled and Solid Gold Cases.

- BECAUSE—They are ACCURATE timepieces.
- BECAUSE—They are SOLD only to the TRADE.
- BECAUSE—They give SATISFACTION to your CUSTOMERS.
- BECAUSE—They are PROFITABLE, as no prices are advertised in any journal.

The "OMEGAS" are Pendant Set, fit 0, 12 and 16 size Waltham cases, and are made in 6 different grades, as follows:

- 7 Jewels, Expansion Balance, Double Roller, Nickelized.
- 15 Jewels, Expansion Balance, Double Roller, Nickel, Pat. Reg.
- 17 Jewels, Expansion Balance, Double Roller, Nickel, Pat. Reg., adjusted.
- 21 Jewels, Expansion Balance, Double Roller, Nickel, adjusted to 5 positions.



Pendant Set. 0 Size. WITH SECOND HAND.

Warranted Fine Timepieces. ALL PARTS INTERCHANGEABLE. Above made to order with dealer's name if desired.

E. E. ROBERT, 3 Maiden Lane, New York; CROSS & BEGUELIN, 17 Maiden Lane, New York, Selling Agents.

**Last Week's New York Arrivals.**

THE CIRCULAR has perfected arrangements for obtaining the names and hotel addresses of all the latest buyers visiting New York, and each day posts in its office, 11 John St., cor. Broadway, a bulletin which every member of the trade is cordially invited to copy.

- Albany, N. Y., F. W. Hoffman, Imperial.
- F. D. Mix, New Amsterdam H.
- J. A. Becker (J. G. Myers), 487 B'way.
- Alexandria, Va., S. S. Hopkins, Union Sq.
- Asheville, N. C., A. M. Field, Manhattan.
- Boston, Mass., A. S. Adams, Manhattan.
- Baltimore, Md., A. H. Fetting, Herald Sq.
- Charleston, S. C., T. S. Wilbur (T. A. Wilbur & Son), Hoffman H.
- Chicago, Ill., Miss C. Green (Siegel-Cooper Co), 6th Ave. & 18th St.
- Cincinnati, O., S. Fox (Fox Bros. & Co.), Astor H.
- Coatesville, Pa., I. D. Landis, B'way Cent.
- Cohoes, N. Y., T. G. Timpane, Grand Un.
- Fall River, Mass., A. Gaudette, Marlbor'h.
- Jamestown, N. Y., J. H. Kaiser, St. Denis.
- Lancaster, Pa., H. J. Cain, Astor H.
- New Bedford, Mass., L. E. Shurtleff, Broadway Central H.
- Ogdensburg, N. Y., J. E. Bell, Park Ave.
- Philippi, W. Va., W. G. Riley, Sturtevant.
- Pittsburgh, Pa., C. W. Wattles (W. W. Wattles & Sons), Imperial H.
- S. F. Roberts (E. P. Roberts & Sons), New Amsterdam H.
- Providence, R. I., J. A. Foster, Manhattan.
- Rochester, N. Y., M. Rosenbloom, Astor.
- Scranton, Pa., N. B. Levy, Astor H.
- St. Louis, Mo., I. Salomon (Barr D. G. Co.), 621 Broadway.
- E. T. Merrick, (Merrick, Walsh & Phelps Jewelry Co.), Everett H.
- Susquehanna, Pa., A. M. Bronson, New Amsterdam H.
- Tampa, Fla., S. B. Leonardi, St. Denis H.
- Troy, N. Y., J. W. F. Podmore, Astor H.
- J. H. Snyder (R. C. Cornesky), Bay State H.
- Tyrone, Pa., F. H. Acklin, Astor House.
- I. P. Walton, Astor House.
- Wheeling, W. Va., J. W. Grubb, Marlbor'h.
- C. N. Hancher, Imperial H.
- Winston, N. C., F. N. Day, Astor House.

The death occurred a few days ago of William Tall, South Haven, Mich.

**Jewelers' Day at Philadelphia.**

Large Throngs of Jewelers Accept the Courtesies of the Philadelphia Jewelers' Club.

PHILADELPHIA, Pa., Nov. 8.—Bright, crisp weather greeted nearly 500 jewelers from all parts of the country at the National Export Exposition yesterday. Contingents of jewelers, their wives, families and friends began to arrive in this city all day Monday and made their rendezvous at the headquarters of the Philadelphia Jewelers' Club, 1225 Chestnut St. The throng was made up of craftsmen from Chester, Wilmington, Baltimore, Washington, Boston, Harrisburg, Trenton, New York, Chicago, St. Louis and other points. It was an 18-karat crowd linked by chains of good fellowship, a jolly, rollicking, good natured throng which pinned its faith to the Exposition and was as happy as could be.

According to the programme, which, however, was of an entirely informal nature, the crowd gathered between 7 o'clock and 8:30 o'clock in room 16 of the second floor of the South Pavilion. Here they were greeted by J. Warner Hutchins, president of the club, with words of kindly welcome. A big crowd came over from New York and was interested in the foreign samples department. It would be useless to try to record the names of those who made up the gathering; suffice it to say that many prominent jewelers in the east were present and representatives were sent from big western and southern firms.

At 11 o'clock the happy throng left the grounds, but there was a reunion of the male element at the Jewelers' Club, where a dainty cold lunch was served. Here the crowd was entertained until the "wee sma'" hours of the morning by talent recruited from local theatres. The day and evening were altogether eminently satisfactory to the guests of the Jewelers' Club and equally satisfactory to Mr. Hutchins, who suggested Jewelers' Day.

George Kleiner, jeweler, Bloomington, Ill., was called to his home in Wisconsin the early part of last week by a telegram announcing the serious illness of his father. The elder Kleiner was hurt in Chicago two years ago, and it is supposed that the injury ultimately caused his death.

**Special Designs, Special Advantages.**

To be able to offer a customer a watch case with any special design, emblem or monogram that he may desire is one of the advantages of handling Bell Gold-Filled Watch Cases.



There are many other advantages, not to be obtained in any other case. One of them is to

**Buy of the Maker.**

**THE BELL WATCH CASE CO.,**

**CINCINNATI, OHIO.**

SCIENTIFIC RUBIES	CATSEYES	SAPPHIRES	DIAMONDS	RUBIES	EMERALDS	PEARLS	PEARL NECKS	PEARL ROPES	Pearl Collarettes, mounted with Diamond Bars.
OPALS	<p><b>PEARLS, DRILLED AND UNDRILLED.</b></p> <p><b>PEARL ROPES, NECKS and COLLARETTES.</b></p> <p><b>We are buyers of American Pearls.</b></p>								
OLIVINES	<p>LONDON: <b>JOSEPH FRANKEL'S SONS,</b> 68 Nassau Street, NEW YORK.</p> <p>19-20 Holborn Viaduct. <b>TELEPHONE, 3899 CORTLANDT.</b></p>								
<p><b>FANCY COLORED DIAMONDS and GEMS in PEARLS and PRECIOUS STONES.</b></p>									

# Simplicity of Construction

combined with superior workmanship, is what makes the

## Trenton Watches

the most reliable of all low-priced movements.



Trenton, 6 size, stem-winding, lever setting, Hunting, 7 jewels, nickel damaskeened, brass and steel composition balance, screw bankings, straight line lever escapement, hardened and tempered hairspring, quick train.

The "Trenton," for the price, far surpasses any movement ever placed upon the market.

SEND FOR PRICE-LIST.

The Trenton Watch Co.,  
Trenton, N. J.

## SILVER NOVELTIES

### SIMMONS & PAYE,

"The Souvenir House,"

129 Eddy St., Providence, R. I., will mail to any jeweler on request a copy of their latest catalogue, illustrating manicure goods, toilet goods, and silver-mounted glass goods.

### Mysterious Robbery in the Jewelry Store of Samuel Oster.

PHILADELPHIA, Pa., Nov. 12.—Samuel Oster, jeweler, 719 Sansom St., was robbed Tuesday in a mysterious manner of a tray of diamonds worth upwards of \$500. There is absolutely no clue to the thief. Oster's shop is in "Jewelers' Row," and is located at the rear of the first floor of 719 Sansom St. So carefully did the thief work that the jewels were stolen and the theft not discovered until an employe took account of stock before locking up for the night.

Mr. Oster, his employes and the police are mystified and cannot imagine how the gems were stolen, as the robbery was committed in broad daylight and while the salesmen were about the establishment. The police say the thief was a professional, as no amateur could have done the job so deftly.

### Death of W. H. Craig.

EL PASO, Ill., Nov. 10.—W. H. Craig, a jeweler of this city, 62 years of age, died Sunday at midnight from consumption. He was a native of Pennsylvania, but came to Canton, this State, in 1865. He has been a resident of this city since 1892.

S. Sutter, jeweler, Russell, Kan., is now paying a visit to Hawaii, for the purpose of finding a good location for a jewelry store in the islands, and during his absence his Russell establishment is in charge of Henry Sutter.

### Boston.

Henry W. Patterson, of Smith, Patterson & Co., has been re-elected president of the famous Point Shirley club.

A. R. Harmon, Montreal agent for Robbins, Appleton & Co., has been in Boston on a visit to the home office the past week.

Mr. Glaenger, of Glaenger Frères & Rheinboldt, New York, has been in Boston the past week on a business trip. He expects to sail for France next month.

J. C. Sawyer, who sprained his knee a week ago Sunday, is improving and is able to be at his place of business, although obliged to use a crutch and cane in getting about.

Business is brisk with all the jobbers. Smith, Patterson & Co. report pressure of work which compels them to keep a large force employed evenings. This will probably continue until the holiday rush is over. Nearly every jobber and wholesaler in this city finds Fall trade away ahead of the record in previous seasons. Nelson H. Brown reports an unprecedented demand for clocks, and manufacturers thereof are delayed on filling orders. Buyers in town are reported as follows: Charles H. Place, St. Albans, Vt.; F. E. Dana, Warren, R. I.; Jos. Lajoie, Worcester; W. H. Elliott, Pawtucket, R. I.; Mr. Newcomb, for L. H. Pratt & Co., Fitchburg; W. E. Hobbs, North Brookfield; James Tonge, Lawrence; J. H. Caswell, Bridgton, Me.; A. W. Gunnison, Hudson; Willis Carter, of Carter Bros. Co., Portland; C. W. Ambrose, Natick.

## The Leader

...IN...

HIGH GRADE  
WATCHES

—IS THE—

## VACHERON & CONSTANTIN,

GENEVA, SWITZERLAND.



FIRST in

Quality,  
Adjustment,  
Durability,  
Style.



FITS ALL SIZES  
OF AMERICAN  
CASES.

{ NEW GRADES  
SIZES  
IMPROVEMENTS.

{ SPECIAL GRADES  
FOR RAILROAD  
MEN.

EDMOND E. ROBERT, 3 Maiden Lane,

SOLE AGENT,

New York.



# WALTHAM WATCHES

*are the best and best-known watches  
in the world.*



Ralph Waldo Emerson, in his Essay on Eloquence said in speaking of a man whom he described as a Godsend to his town. "He is put together like a Waltham Watch."

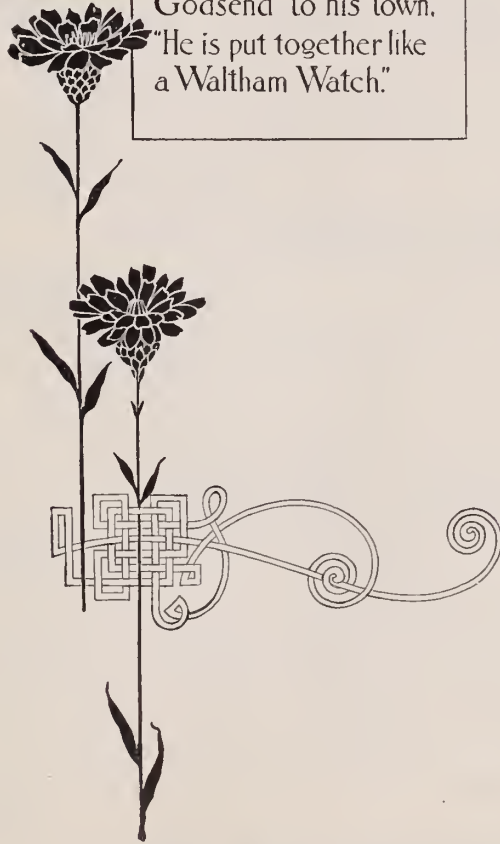

**DIAMONDS.**  
**Wm. S. Hedges & Co.,**  
 IMPORTERS OF  
**Diamonds and Precious Stones.**  
**DIAMOND JEWELRY.**  
**170 Broadway, New York.**  
 26 Holborn Viaduct, London.

# SCHULZ & RUDOLPH,

....Importers and Cutters of....

**..DIAMONDS..** .....AND OTHER....  
**PRECIOUS STONES.**

SOLE AGENTS FOR THE CELEBRATED

**JULES JÜRGENSEN WATCHES AND**  
**COPENHAGEN, CHRONOMETERS.**

**28 John and 65 Nassau St., New York.**

**MOUNT & WOODHULL,** FORMERLY WITH LATE FIRM OF  
 RANDEL, BAREMORE & BILLINGS,  
 .... IMPORTERS OF ....

**Diamonds, Other Precious Stones, Pearls, Etc.,**  
**Makers of fine DIAMOND JEWELRY,**

**26 MAIDEN LANE (SOUTHWEST CORNER), NEW YORK.**  
 NASSAU STREET

JOHN C. MOUNT.

ADDISON W. WOODHULL.

**FOX & CO., Lapidaries** and importers  
 of  
**....Precious Stones.**  
 Now at.....  
**22 JOHN STREET,**  
**NEW YORK.**  
 Cutters of American Gems and Fine Miniature Glasses  
 Fine Stone Seal Engraving  
 (Crests, Monograms, etc.), a Specialty.

# The Bowden Rings

ARE COMPLETE IN VARIETY, CORRECT  
 IN QUALITY AND PERFECT IN FINISH.  
 WE MAKE EVERY VARIETY OF FINGER  
 RINGS

**J. B. BOWDEN & Co.,**

**1 MAIDEN LANE,**

**NEW YORK.**

## Precious Stones: London Market

HATTON GARDEN, London, Eng.  
 Nov. 4, 1899.

It is stated on good authority that no further rise in rough diamonds has been announced by the Syndicate within the past week. All the chief American buyers are, of course, already home again, and in colored stones as well as diamonds there is insufficient business upon which to base any reliable report.

Pearls continue at good prices, and other gems much as usual, but trade all round is very quiet.

Very little news gets through from Kimberley. The town does not appear to have suffered yet from Boer shells. An artillery attack would probably have serious results as far as the mining works are concerned, the machinery (e. g., the washing plant) being practically at the mercy of a cannonade. The employes enrolled as combatants are, of course, all whites; the natives in the compounds are working as usual. How far this condition of affairs has affected production it is impossible to say. The London secretary of the DeBeers Co., to whom I applied on behalf of THE CIRCULAR, states that he has "no information except that which appears in the newspapers." No information is obtainable as to the Jagersfontein mine, which, although in the Orange Free State, has its headquarters at Kimberley.

The DeBeers Co. are probably unique in the history of industrial enterprise in their defensive equipment. They are said to own 6 9-pounders, 6 7-pounders, 10 Maxims and about 5,000 Lea-Metford rifles, while they practically support the Volunteer Regiment and the Diamond Fields Horse and Artillery Corps, nearly all of whom are employes of the company. R. F.

### Notes from London.

*Merchandise Marks Act.*—An important prosecution under the Merchandise Marks Act, 1887, affecting the watch trade, has been commenced by Mr. Berry, a watch movement maker of Prescott, and the Lancashire Watch Co., Ltd., against H. Williamson, Ltd., large makers of watches, of London and Coventry. The prosecution alleges that watches sold as "English levers" contained a large proportion of foreign (Swiss) parts. The cases of all the watches concerned bore English hallmarks. Key-winders containing 81 parts included 63 of foreign origin, 17 doubtful and 1 English. Keyless watches contained 117 parts, 82 foreign, 28 doubtful and 7 English. The section of the Act relied upon provides that "where a watch case has thereon any words or marks which constitute or are to common repute considered as constituting a description of the country in which the watch was made, and the watch bears no description of the country where it was made, those words or marks shall prima facie be deemed to be a description of that country within the meaning of this Act. . . . the expression 'watch' means all that portion of a watch which is not the watch case." The defence is that the watches concerned are truthfully described as "English levers," although containing a "certain amount of foreign material." The result will be of

great importance to the watch trade. It is based on what has been a notorious grievance for a long time, but English makers of movements have hitherto almost entirely neglected to avail themselves of the protection afforded them by the Act. The penalties under the Act are, on summary conviction, imprisonment not exceeding 4 months or fine not exceeding £20, or on conviction on indictment not exceeding 2 years' imprisonment or fine or both, and in either case forfeiture of the goods. In this case the defendants being a limited company a fine would, no doubt be imposed. In all 1,300 watches were seized at the defendant company's.

*The Peel Heirlooms*, the sale of which was authorized by the law courts some months ago, took place at Willis's rooms a few days ago. The total realized was about £6,000. The dinner services, numbering 10 dozen plates, fetched from 5 to 8 shillings per oz. An old English two handled vase and cover, weighing over 24 oz., realized 131 shillings per oz. An Irish potato ring 120 shillings per oz. A rare, engraved, parcel-gilt beaker and cover 73 shillings per oz. Two handled flower patterned basket, weighing over 45 oz., 50 shillings per oz. Four gilt pillar candlesticks, floral designs, 16 shillings per oz. (£141 the pair.) Old English kettle, embossed with game subjects in high relief, 25 shillings per oz. (£110 8s.).

*Buckles and Buttons* are the principal features in this season's fashionable costumes. To be entirely correct and to show you are in the swim, says a fashion correspondent, you must wear buckles on your frock, on your waistband, on your bodice, on your skirt, on your hat, and last, but not least, in your hair. To be very smart the buckle should be of old paste or enameled on gold or silver, and the ones worn at the same time should all match, though they need not be of the same size. Buttons are worn in profusion, but are very small and usually of steel. Silver will, no doubt, come into use in due course.

*A Popular Pattern* in gem rings this season consists of a band of metal overlapping in front, each end mounted with a large stone, as shown in sketch.



POPULAR RING IN LONDON.

A pearl and diamond or other combination give a good appearance; the shank is mostly quite plain. R. F.

Nothing has as yet been heard of jeweler J. Manning, Plain City, O., who disappeared some time ago. It seems his family do not know where he went, or, at least, if they do, they are deceiving the people about that town by feigning ignorance. It is said that Manning owed many persons in town, but so far it has not been ascertained whether he caught any wholesale jewelry houses or not. He seemingly did a good business for some time in Plain City, and his going away in the manner he did was a surprise to many.

ESTABLISHED 1840.

# Chester Billings & Son,

Successors to **RANDEL, BAREMORE & BILLINGS,**

IMPORTERS OF

1840 RANDEL & BAREMORE.  
1866 RANDEL, BAREMORE & CO.  
1880 RANDEL, BAREMORE & BILLINGS.

# DIAMONDS

OTHER PRECIOUS STONES AND PEARLS.

58 Nassau Street,  
29 Maiden Lane, 22 Holborn Viaduct,  
NEW YORK. LONDON, E. C.

DIAMOND JEWELRY.

## Pearl Perfection.

Perfect in quality, perfect in assortment, our stock of Pearls is one of the largest owned by any house in America.

### Fred. W. Lewis & Co.,

No. 1 MAIDEN LANE (Cushman Building), NEW YORK.

## Oppenheimer Bros. & Veith,

Importers and Cutters of

Dealers in

### Diamonds

### Watches,

Cor. Nassau and John Streets,

(PRESCOTT BUILDING.)

....New York....

Amsterdam,  
2 Tulp Straat.

London,  
45 Holborn Viaduct.

## John F. Saunders, Cutter and Importer of

# DIAMONDS AND OTHER PRECIOUS STONES.

FINE PEARLS A SPECIALTY.

68 Nassau St., cor. John St., Sheldon Building, Room 16, NEW YORK.

RUBIES.

SAPPHIRES.

## C. G. MALLIET & CO.,

EMERALDS.

14 MAIDEN LANE, N. Y.

DIAMONDS.

## PEARLS.

**The Scope.**

We do not confine ourselves to dealing in one grade of goods, but simply to dealing in one line.

We deal in everything that pertains to that line, from the most expensive to the most moderate.

The result of this thoroughness is manifest in the assortments awaiting your inspection.

**Alfred H. Smith & Co.,**

182 Broadway, N. Y.

CHICAGO.

LONDON.

**DIAMONDS**

And Other Precious Stones.

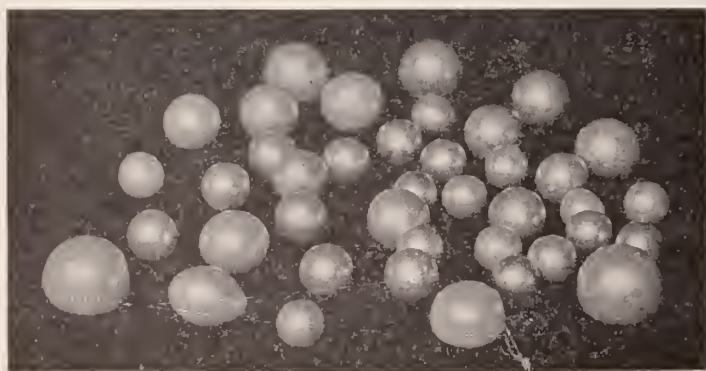
**"The Pearl House."**

PEARLS PHOTOGRAPHED EXACT SIZE.

Our recent shipments of Pearls are worthy of most careful consideration. We have no salesmen; call or drop us a line.

**Eisenmann Bros.,**

Importers of Pearls and Precious Stones,

21 and 23 Maiden Lane, = = NEW YORK.

Paris: 3 Rue Saint Georges.

**FALL and HOLIDAY FASHIONS.****A LADY'S RAMBLES AMONG THE JEWELERS.**

An important brooch illustrative of the newest order of this ornament employs a beautiful peridot, oval cut, and more than an inch across its larger axis, as the central stone. Beyond the center a row of small rubies alternating with brilliants affords just a touch of color in contrast with the transparent olive-green of the peridot. As an outer border are points of large diamonds, which, being mounted upon springs, vibrate and scintillate unceasingly. The effect of the whole accords with the idea of richness and splendor now entirely *en vogue* in dress and ornament.

\*

The Princess gown is giving increased vogue to girdles. These come in linked plaques of gold or silver or in heavy chains fastening at the front, with one end hanging in a jeweled pendant.

\*

Charming new card cases and pocket-books depart from the commonplace of their kind, for they are all in soft, undressed skins, usually of a delicate grey tone, in chamois, reindeer, lizard, etc.

\*

The corners of the flat purses in undressed leather show exquisite traceries of brilliants and olivines. A real button-hole, worked with silk, and a jeweled button, oftenest a pearl or diamond, serve for a fastening. Sometimes there is but one of these buttons, at others two or even three.

\*

Convenient and very smart clasps for feather or fur boas take somewhat the form of a letter S laid upon its side. A handsome design is a serpent thus twisted and jeweled with appropriate stones.

\*

Particularly suitable for a watch bracelet is an automatic or self-closing affair of English invention, which adapts itself to any sized wrist, and has no fastening to become unclasped.

\*

Fob chains continue much in fashion for men.

\*

Silver gilt toilet brushes with hand painted scenes on the back are among artistic productions. These employ charming floral designs, such as lilies-of-the-valley, violets, wild roses, chrysanthemums, etc.

\*

Reeded, fluted, waved or richly carved patterns are all in evidence on crystal vases, cups, jugs, etc.

\*

Exquisite smelling bottles come in Favre glass with silver gilt mountings.

\*

A very light band of gold is used in fine rings, set with diamonds, pearls, emeralds or sapphires, all of which serve as engagement rings, with quite a feeling existing for the colored stones.

\*

Broken enamel sticks, with a gem between, make a pretty chain for a girl, especially in blue enamel and pearls.

ELSIE BEE.

**The Detained Peabody Gems.**

**The Workings of a Section of the Tariff Law Involved in Their Detention.**

Adolph Peabody last week appealed to the Treasury Department for an order permitting him to recover from the Collector of the Port of New York such diamonds of American cut as were contained in the lot detained three weeks ago. It will be remembered by readers of THE CIRCULAR that about \$15,000 worth of diamonds belonging to Peabody were detained by the Collector pending an investigation on charges that they had been smuggled into this country. Mr. Peabody, it is alleged, admitted that he had brought them here, but claimed that, having purchased them in this country before he went abroad, he did not believe that any duty was required to be paid on them on their return. Among these goods are a number that he claims were cut in this country, while the remainder of the diamonds and a quantity of other precious stones were originally cut abroad.

Paragraph 483 of the present Tariff law provides for the re-importation of American manufactures, provided that certain regulations are complied with by the person who exports and then imports them. Mr. Peabody applied for an order permitting him to recover the American cut goods despite the fact that these regulations had not been complied with. No decision by the Department had reached Collector Bidwell up to Monday. As already told in THE CIRCULAR, an action to confiscate the goods cut abroad will undoubtedly be commenced. The fate of the goods claimed to be American cut depends upon the decision of the Department at Washington, and if this be favorable to Peabody, upon his ability to identify these goods absolutely as the diamonds cut here and purchased by him.

**The Mysterious Death of William Hogg Being Investigated.**

SAN FRANCISCO, Cal., Nov. 10.—One of the most remarkable cases that has ever called for police investigation in this city has just come to light. William Hogg, a well known jeweler, who resided at 1240 Bush St., was picked up Sunday night a week ago on a sidewalk in one of the most thickly populated portions of the city. He passed through the Receiving Hospital to the City and County Hospital, where he died, as "John Doe," his identity having been lost in the transfer. The body passed through the hands of the Coroner into those of an undertaker and was buried in Potter's Field, while the relatives were searching the city for the missing man.

Only by the merest accident was the identity of the body discovered. It has been exhumed and examined, and, in addition to the story of its buffetings during the past week, it is possible that another chapter, showing foul play, will be added. In other words, the relatives are convinced that the official eyes under which Hogg's body passed were not only criminally careless concerning his identity, but they were closed to a bloody crime.

Mr. Hogg, who was 43 years old, left his home Sunday evening, a week ago, to visit

his uncle, S. M. West, 1211 Bush St., with whom he had an engagement to play whist. On his way he stopped at the saloon of C. G. Ault, at the corner of Pine and Hyde Sts., where he collected 50 cents due him for repairing a clock. He spent the money there and left the place, according to the story told by those who frequent the resort. Some time later he was brought back to the place by John Nixon, who claimed that he had found the man lying in the street in a semi-conscious condition. The relatives are strongly suspicious that the dead man met his injuries in the saloon, from which he was taken to the Receiving Hospital.

The business of the late Jonathan H. Weston, Vestal, N. Y., is closed.

**Jewelers' Gold Bars Withdrawn and Exchanged at New York.**

*Week Ended Nov. 11, 1899.*

The U. S. Assay Office report:  
Gold bars exchanged for gold coin....\$236,576.74  
Gold bars paid depositors..... 46,242.14

Total .....	\$282,818.88
Of this the gold bars exchanged for gold coin is reported by the Sub-Treasury as follows:	
Nov. 6 .....	\$38,257
" 7 (election day) .....	56,776
" 8 .....	36,031
" 9 .....	37,887
" 10 .....	26,628
" 11 .....	
Total .....	\$195,579

W. A. McReynolds has removed from Springfield, Mo., to Aurora, Mo.

**A  
Timely  
Suggestion.**

Your stock of Diamonds and Precious Stones should be full and attractive, to meet a large Holiday trade; if it is not so, lose no time in putting it in that condition. Our Diamond and Precious Stone Department can render you valuable assistance in the work.

Loose Diamonds and Mounted Pieces in great profusion.

**HAYDEN W. WHEELER & Co.,**

**TWO MAIDEN LANE, N. Y.**

**50 HOLBORN VIADUCT, LONDON.**



# This is How

the good times have affected the Diamond business.

Those who were able to buy Diamonds a year ago are now buying higher-priced Diamond pieces.

Those who a year ago had to be content with an ordinary piece

of gold jewelry are this year buying Diamond Jewelry.

As we have remarked before, "Our line of Diamond Jewelry is the successful line of the season."

*Kohn & Co*  
 9.11.13 MAIDEN LANE.  
 NEW YORK.

## Rubies and Emeralds.

BYRON L. STRASBURGER & CO.,

Watches and Diamonds,

17 MAIDEN LANE,

NEW YORK.

### WELL-MADE GOLD LINKS.

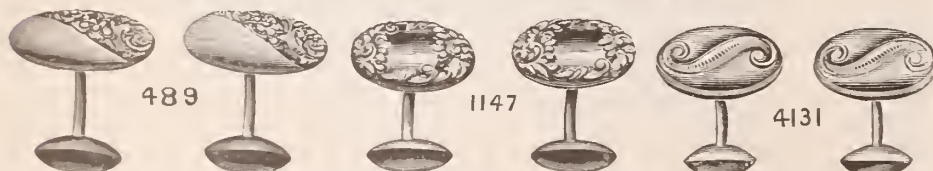

489

1147

4131

Roman Finish, \$1.25.

Bright Finish, \$1.25.

Roman Finish, \$1.00.

Links with Diamond Brilliants,  
 from \$3.75 per pair up.

LESS CASH DISCOUNT.

(WE HAVE OTHERS.)

*Leys Christie & Co.*  
 MANUFACTURERS OF  
 GOLD JEWELRY,  
 65 NASSAU ST., NEW YORK.

### About 40 Diamonds Stolen.

Gang of Expert Thieves Rob Sigler Bros. Co. in Broad Daylight.

CLEVELAND, O., Nov. 13.—One of the boldest and most audacious robberies that have ever been attempted in Cleveland occurred this afternoon, when about 40 diamonds were stolen in broad daylight from under the eyes of L. M. Sigler, of Sigler Bros. Co.

About 3.30 o'clock this afternoon three men entered the office of Sigler Bros. Co., on the second floor of 52-54 Euclid Ave. One of the men desired to match a diamond which he had, and Mr. Sigler took him into his office and brought out a box of diamonds to show to the customer. While Mr. Sigler's attention was drawn in another direction, a confederate of the pretended customer picked up the box containing the diamonds, slipped it into his pocket and walked out unobserved. The pretended customer, just at this time, also made an excuse, and saying that he would call again, quickly left the office. Mr. Sigler turned to replace the stone that he had taken from the box, and found that the entire lot of diamonds had disappeared, as had the strangers who had been in his office.

Mr. Sigler immediately notified the police, but there is no clue to the thieves' whereabouts or even to their identity, except for their description, furnished by their victim. The stolen box contained between 30 and 40 diamonds, weighing  $\frac{1}{2}$  karat to  $2\frac{1}{2}$  karats each.

It is the opinion of both Mr. Sigler and the police that the men are professional crooks and experts at the business. This is the largest robbery of the kind that has ever taken place in this city.

### Big Jewelry Factory Reported Proposed for Omaha, Neb.

OMAHA, Neb., Nov. 13.—F. H. Scherer, of Scherer Bros., wholesale jewelers, Chicago, is in Omaha for the purpose of establishing a jewelry factory. The plant will, it is said, employ 600 men and supply the trade of the west. Scherer expects to begin work on the plant in January.

### A Carpenter Charged with Burglarizing the Store He Built.

SHELTON, Conn., Nov. 12.—Irving Pierce, a carpenter, about 35 years of age, was arrested Saturday night on the charge of robbing the jewelry store of L. V. B. Hubbard. He was later released on \$200 bail. It is alleged that Pierce, who built the store two years ago, has had a key to the place, and entered it many times, taking money and jewelry.

T. Jones Williams, Uniontown, Ky., has removed to more commodious quarters in that town.

Frank T. Parritt, Bloomington, Ill., is the recipient of congratulations on every hand. He now has one of the finest jewelry stores and stock in central Illinois. His store in the new Greisheim building is a most attractive one.

# Enameled Watches

Iridescent and dull finish

New England Watch Co.  
Waterbury,  
Conn.



## “Elf”

—10 Ligne.

ALL ENAMEL,  
IRIDESCENT:

Blue,	No. 8803
Red,	8805
Green,	8807

INLAID ENAMEL BACK,  
IRIDESCENT:

Blue,	No. 8483
Red,	8485
Green,	8487

DULL ENAMEL:

Chrysanthemum Pattern.

White,	No. 8661
L't Blue,	8663
Green,	8665

Rococo Pattern.

White,	No. 8621
L't Blue,	8623
Green,	8625

## “Cavour”

—15 Ligne.

INLAID ENAMEL BACK:

Blue,	No. 9653
Red,	9663
Green,	9667

The numbers above given call for blue watches—the price list will show the numbers of other colors.

## CHARMING - STUNNING - BEAUTIFUL:

the gleam of the iridescence and the dainty gold florets underlying the enamel produce an effect that is simply exquisite. Our *Enameled Watches* are in all the best colors to match, or harmonize with, the most delicate shades of dress goods. The *Iridescent Enamels* are in dark red, blue, and green (with like colored dials, if desired), and the *Dull Enamels* in light blue, light green, and white, with rich cream dials, figures of either gold or blue, and delicately patterned gold hands.

The enameling is all on Sterling Silver, which gives precisely the same effect as if it were on solid gold, and at a great saving in cost.

*Brooches* may be had to match the watches in designs and colors; attractive boxes add to their effectiveness as holiday packages.

Our last year's enamels were the first to be sold out, and although we have a splendid stock of these new styles for this season, we do not expect the line to last very long.

Decide upon what you want, then *order at once* and *save disappointment*.

THE NEW ENGLAND WATCH COMPANY,  
WATERBURY, CONN.

**Providence.**

C. W. Mott, representing J. B. Bowden & Co., New York, was in town last week.

At 193 Richmond St. the Grant Co. will soon begin the manufacture of plated jewelry.

Edgar B. Wood, of Carpenter & Wood, has returned from a trip through New York and the west.

Frank Barton, of this city, representing P. J. Cummings & Co., Attleboro, has returned from a trip to San Francisco.

Ernest F. Rueckert has established a shop at 144 Pine St., where hub cutting, tool making and die sinking are done.

Edgar E. Craddock, with Fulford & Hobart, has established his headquarters in New York at the Broadway Central hotel.

On Tuesday last, Mrs. Albert Walker, wife of Albert Walker, jobber, died at their residence. Mr. Walker has the sympathy

of a large circle of friends in his bereavement.

Lucian Sharpe, Henry D. Sharpe and Louisa D. Sharpe have been appointed executors of the estate of the late Lucian D. Sharpe.

The Sanford, Bodwell Co., both members of the firm being former employes at the Gorham Mig. Co.'s works, are manufacturing velvet, plush, satin and leather goods for manufacturers of jewelry and silver ware.

Frederick Stedman, the young man who pleaded *nolo contendere* to the charge of committing the larceny of a diamond ring, diamond stud, a watch and a sum of money from the person of Edgar L. Logee, has been sentenced to six years in State prison by Judge Wilbur.

Simon Massell, who, on Saturday, was found guilty of the murder of his wife, was at one time an employe of the Ostby & Barton Co. Nathan B. Barton, treasurer of the company, was a witness at the trial, testifying to hearing Massell say that he was going home to kill his wife.

S. E. Budlong, of S. E. Budlong & Co., met with a bicycle accident one night last week that fortunately was not attended with very serious results, though a wrenched ankle made the use of a cane by Mr. Budlong a necessity. Mr. Budlong was riding along one of the city streets and started to pass a team that was ahead of him. Another team came up at the same moment and tried to pass the other team, and bicyclist and team collided. Mr. Budlong was thrown and, in addition to the wrenched ankle, was bruised quite badly.

After having solicited aid throughout the eastern cities, Herbert Winchester, who, it is alleged, represented that he was employed by Tiffany & Co., New York, as a designer on glass, was arrested in this city last week. The police say that it has been the man's game to solicit aid from

Episcopal ministers, telling them that he was out of work and had a wife and children to support. He represented, they say, that he had been imported by Tiffany & Co. to work as a designer upon glass for them. He was charged with being an idle person, and, admitting the charge, was sent to the workhouse for one year.

On Saturday articles of incorporation of the A. S. Cumerford Co. were filed at the office of the Secretary of State. According to the articles the company are formed for the purpose of engaging in the business of manufacturing and dealing in jewelry and other articles of ornament and use, and of manufacturing and dealing in gold and silver plate, wires and solders. The capital stock is \$25,000, and the incorporators are Arthur S. Cumerford, Frederick E. Tattersall and Eva A. Tattersall. Mr. Cumerford has, until recently, been employed by the E. Lowe Gold Plate Co. The company will do business in this city.

Walter B. Bliss, jeweler, who resides at 118 Indiana Ave., has a cat with which he would be unwilling to part. One night last week burglars forced an entrance into the house, and proceeded to Mr. Bliss's room, where they made ready to begin operations. They removed Mr. Bliss's vest from the head of the bed, where it was hanging directly over his pillow, and took from it a watch, chain and card case. They also emptied his trousers pockets of what change they contained. It was about this time that the cat put in an appearance. He jumped at the burglar, and began an unearthly mewing, that awakened Mr. and Mrs. Bliss. Mr. Bliss arose, and the cat led the way through the dining-room and parlor, Mr. Bliss following. On the floor he found his vest with the pockets emptied. The detectives were notified and are at work on the case, though no clues have been found.

**P. B. Saterlee's Store Robbed of \$600 Worth of Goods.**

MOBERLY, Mo., Nov. 9.—The business house of P. B. Saterlee, on the main business street of the city, was robbed at an early hour last night. Twenty-eight watches, 50 rings, diamonds, pins, cash and other articles, amounting in value to about \$600, were taken. Entrance was effected by way of a transom over the back door. A reward of \$125 has been offered. A good description of the thieves is held by the police force.

**S. Joseph Captured a Would-Be Grab Thief.**

DES MOINES, Ia., Nov. 11.—Fred Beal, who says he is from California, walked into Solomon Joseph's jewelry store, on one of the most prominent corners in the city, this evening, and asked to be shown a tray of diamond goods. It was handed to him and instantly he picked it up, tucked it under his arm, and started for the door. He got outside and was running toward an alley when Mr. Joseph overtook and captured him. All the goods were recovered. Beal is in jail.

W. Fred Newhall, Lynn, Mass., is having his store front remodeled, and will have some handsome new show windows for the holidays.

OTTO K. TREIBS.

PAUL E. TREIBS.

**TREIBS BROS.,**

68 Nassau St., New York.

CUTTERS AND IMPORTERS OF

**Opals.**

F. E. TREIBS,

Oberstein, Germany.

ESTABLISHED 1842.

HERMANN TREIBS.

ALBERT TREIBS.

EMIL TREIBS.

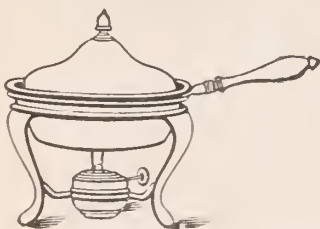

**WHY  
WAIT?**



The holiday trade promises to be the largest in the history of the country.

We are far behind our orders, and any goods you may want for

**CHRISTMAS, ORDER NOW.**

Our new illustrated catalogue sent on application.

**S. STERNAU & CO.,**

Manufacturers of Metal Wares in Brass, Copper and Silver,  
204 Church Street, New York City.



### The Attleboros.

Henry Wexel, recently retired from H. Wexel & Co., disposed of his valuable stable last week.

A brick vault for tools, dies and precious metal was built last week on the outside of the Walter E. Hayward factory.

The new Mossberg factory is nearly completed and the inside fittings and the first lot of machinery are beginning to be set up.

Slight accidents to the machinery caused temporary closing last week of both the David E. Makepeace and Walter E. Hayward factories.

The electric lights, whose slow introduction into the Plainville group of shops has been mentioned, were first used the middle of last week.

McRae & Keeler's operatives enjoyed a week off while the plant was being moved from the Robinson building No. 3 to the new Bates factory.

Scofield, Melcher & Scofield, Plainville, were put to some little inconvenience last week by the sudden bursting of a water pipe in their factory.

William A. Cook, salesman and partner in the new firm of Fontneau & Cook, has returned from his first trip. He introduced his house to the western trade and secured a good showing of orders.

Alton H. Riley went to New York last week to take charge of the New York office of Riley, French & Heffron. He closed his North Attleboro home and took Mrs. Riley with him to the metropolis.

The power was turned on last week in the new Bates shop in the burned district. Completed outside and nearly so within, it is one of the largest and best suited to the business of all the new factories since the great fire.

The employes of Carter, Qvarnstrom & Remington discovered last week that their employer, Ernest J. Qvarnstrom, becomes

a benedict on the date of this issue. They acted promptly, therefore, and on Saturday presented to him a handsome Morris chair.

The force of operatives which went on from 9 o'clock P. M. to 7 o'clock A. M. in the factory of the James E. Blake Co. was largely augmented the latter part of last week. This is one of the busiest houses of the section, and the only one with a 24-hour schedule. Mr. Blake says he expects these conditions to last well up to the opening of the new year.

Clarence L. Watson, of the Watson & Newell Co., has always lent his influence and been ready to put out money to encourage the fraternal feeling which exists among his operatives, especially those who reside in the corporation village about the factory. Last week he fitted up a club room and social headquarters for them for use out of working hours.

A political circular from Republican headquarters passed through the Attleboros in the last State campaign, reminding the voters that the present extraordinary business boom among the jewelers, which reflects prosperity on all the other businesses in the Attleboros, is largely due to Republican administration of public affairs. The vote was a very large one, despite the fact that the shops could hardly let their men go long enough to visit the polls.

Last week the Attleboro board of health were again importuned to take steps against the completion and operation of a refinery on Union St. by George M. Baker, as a branch to his Providence concern of the same kind. They refused to take any such steps on the ground that they have been assured by the management that with modern processes and with the apparatus and equipment being installed there is not the slightest danger of the place being a nuisance to the neighborhood.

Representatives of C. A. Marsh & Co., the W. H. Wilmarth Co., the Bay State Optical Co., the Attleboro Mfg. Co. and P. J. Cummings & Co. accompanied the police to the county seat last week to give testimony before the grand jury in the cases against Eugene and Clarence Skinner, of Attleboro, charged with breaking and entering and larceny in these various shops. The cases were enlarged upon some time ago in these columns, all growing out of a long series of cleverly concealed thefts from the Marsh firm. The two men were caught in the building by police stationed for that purpose, and, upon their arrest, their homes were found crowded with hundreds of dollars' worth of plunder, the accumulation of years. Both men were old and respected members of the community, and the popular surprise has been very great.

### Newark.

William M. Durand died last Wednesday. The deceased was born in Jefferson Village, near Maplewood, in 1816, and learned the trade of watch case spring setting, in this city. He came to Newark 50 years ago, and became connected with the firm of Durand & Co., on Franklin St., in which establishment he worked at his trade until 1871, when he was forced to retire because of blindness. The interment was in the Clinton Cemetery.

The residence of William J. Lieb, 22 Chestnut St., was entered by thieves Nov. 5, during the absence of the family, and jewelry valued at \$1,000 stolen. Mr. Lieb, who was formerly in the jewelry business, had a large number of articles in which he used to deal locked up in a bureau. The thieves broke this open and secured a dozen gold and a dozen silver watches, 25 gold rings, several breastpins, some silver ware and small articles. The robbery was discovered when the family returned.

## Gifts for Men

Gold Cigarette Cases,  
Gold Match Boxes,  
Gold Cigar Cutters,  
Gold Pocket Knives,

Ornamented with  
DIAMONDS  
and Precious Stones.

HIGH-CLASS NOVELTIES of all kinds in Gold and Silver,  
made handsomely, heavy and exclusively  
for the Jewelry Trade.

860 Broadway, N. Y.  
42-46 Hill Street, Newark, N. J.

**Woods & Chatellier,**  
Gold and Silversmiths.



TRADE-MARK.

**Canada Notes.**

Judgment has been obtained against A. B. White, watchmaker, Picton, N. S.: amount \$96.

W. J. Barr, manager of the Goldsmiths Stock Co., Toronto, went on a business trip to Montreal this week.

A. E. Lawrence, jeweler, Little Current, Ont., has assigned. He began business early this year with but little capital.

Simon Schreck, jeweler, and wife, St. Thomas, Ont., have given a renewal chattel mortgage to Isabella McIntyre for \$157.

Out-of-town visitors to Toronto last week included G. S. Rutherford, Sault Ste. Marie; W. S. Frost, Orillia, and E. O. Felt, Oshawa.

Barre Bros. & Co., who, last week, purchased from H. B. Clarke the remaining jewelry stock of Levy & Michaels, Halifax, N. S., paid for it the sum of \$13,683. Clarke had already sold nearly \$8,000 worth of the stock.

The use of individual communion cups is steadily increasing. They were employed for the first time in the Metropolitan Methodist Church, the largest church in Toronto of that denomination, on Sunday last.

As mentioned last week, Galbraith & Co., Shelburne, Ont., have failed and now are endeavoring to compromise with creditors at 25 per cent. This business is owned by Mrs. A. V. Galbraith, whose husband failed four years ago.

Mr. and Mrs. Henry Birks, Montreal, have left for Atlantic City, N. J., where

they will spend a 10 days' holiday. They are accompanied by their youngest son, Gerald, and their two little grandsons, children of Mr. and Mrs. Wm. Birks.

The jewelry trade is going ahead in the thriving and comparatively new town of Nanaimo, B. C. S. E. Roberts has the corner store, Green block, and makes a specialty of mounting nuggets. V. Genoni has a stand at 21 Commercial St., and L. H. Hills has also hung out a shingle on Commercial St.

Hughan & Co., jewelers, Lindsay, have made an assignment to Peter Mitchell, of the same town. A meeting of creditors is called at the office of Stewart & O'Connor, Lindsay, on the 14th inst. The liabilities amount to \$1,850, and the assets to \$1,600. The firm offer to compromise at 15 cents on the dollar.

In response to a circular issued by a trade journal with a branch in Australia, many Canadian manufacturers have replied that they are too busy with home business to look farther afield just at present. The Meriden Britannia Co., of Hamilton, state that they do all their trade with Australia from their United States factory.

Charles Potter, who had been in business in Toronto as an optician since 1853, died on the 3d inst., at the residence of his daughter, Mrs. Campbell-Black, 211 Jarvis St., after a long illness from paralysis. The deceased, who was born in London, Eng., was 68 years of age, and was for many years treasurer of the Central Methodist Church.

A list of the jewelry, etc., taken from the sailors of the steamer *Scotsman* at Liver-

pool and Queenstown has been forwarded to Chief Detective Carpenter, of Montreal. As the passengers are now widely scattered in the United States and Canada it is desired that this information be widely known so that the property may be more quickly identified.

S. Frenkel, wholesaler, Toronto, is removing from 55 and 57 Yonge St., where he occupied the upper flats, to the adjoining building, 53, which has been entirely refitted and decorated throughout in first class style. The ground floor will be occupied as offices and salesrooms for watches. The change will considerably extend his business facilities and enable him to increase his staff.

A bicycle was recently left for repairs at the Cleveland bicycle factory, Toronto Junction. Before it had been touched an employe of E. M. Morphy, Yonge St., jeweler, informed the people of the factory that it had been used to conceal stolen jewelry. On removing and deflating the tires jewelry valued at \$20 was found ingeniously secreted inside. The articles had been stolen from Mr. Morphy's store a few days previously, and the thief, afraid either to leave his booty at home or retain it on his person, concealed it in the tires. He subsequently became conscience-stricken and confessed to Mr. Morphy, telling him where the goods were to be found.

S. B. Dugger & Co., Aurora, Mo., recently sold out.

Joseph J. Pool & Son, Earlville, Ill., have been succeeded by Pool & Snow.

**GOLD-HEADED CANES ARE A SPECIALTY WITH US.**



**SIMONS, BRO. & CO.,**

Silversmiths,

Thimble Makers and Manufacturing Jewelers.

PHILADELPHIA,  
616 Chestnut Street.

NEW YORK,  
19 Maiden Lane.  
41 Union Square.

Write for an illustrated sheet. You'll be surprised at the large and handsome line we make.

THE  
"PRISCILLA."  
STERLING SILVER.

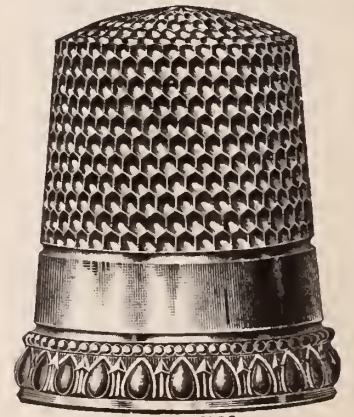

PAT. MAY 31, 98

Our Catalogue shows a great variety of Gold and Silver Thimbles.

CHICAGO,  
702 Columbus  
Building.

**Connecticut.**

J. Allsopp & Co., watchmakers and jewelers and opticians, opened a new store at 30 Elizabeth St., Derby, on Saturday, Nov. 11.

Archer Case has closed his watch repairing business in West Winsted and is now employed as inspector in the Seth Thomas Clock Co., Thomaston.

Miss Christine Sorenson, who represented the E. A. Bliss Co. at the Business Men's carnival, Meriden, was presented by the Bliss company with a handsome necklace.

J. E. Spaulding, receiver for the Winsted Optical Co., in liquidation, has applied to the Superior Court for judgment authorizing him to pay a 20 per cent dividend now in the hands of the receiver.

George C. Edwards, of the Holmes & Edwards Silver Co., Bridgeport, is having erected at Park Place a handsome residence, which, when completed, will compare favorably with any in that city.

The class pins for Miss Johnson's private school, New Haven, have just been completed by the S. Goodman Co. They are of solid gold, with a band of black enamel running diagonally across with the Greek letters "M. J. S."

Harriet E. Barbour, wife of Lucius A. Barbour, of the Barbour Silver Co., died in Hartford last week. She was a sister of Gen. Alfred C. Barnes, of Brooklyn, the publisher, and a daughter of the late Alfred S. Barnes.

The manufacturing plant of C. Rogers & Bros., Meriden, is now one of the best equipped and busiest concerns in Meriden. Within the last month two radical changes resulting in decided improvements have taken place at the factory. The improvements consist of a complete electric lighting outfit and the sinking of 20 driven wells to furnish independent water power in all departments.

A bill of complaint was filed in the United States District Court, in Hartford, Nov. 7, by the Lalanc & Grosjean Mfg. Co., of New York, against Manning, Bowman Co., Meriden. The complainants allege that the defendants, without the complainants' consent and contrary to their will, have applied to articles of enamel ware the patented trade-mark "Pearl," and are selling the same to the trade. The complainants estimate their trade-mark at a value not exceeding \$50,000, but cannot exactly state the loss and injury suffered by reason of the wrongful acts of the defendants, but believe the damage to be not less than \$5,000. They asked that the defendants be compelled to render before a commission or master of the United States Court a complete account of the profits derived, and be decreed to pay damages; that a preliminary injunction be granted restraining the defendants from manufacturing the patented articles and that they pay the costs of the suit.

**Syracuse.**

Herbert C. Watts, optician, and Miss Clarissa Burns, of Great Bend, Pa., were married on Wednesday last at Grace Episcopal Church, in Great Bend. After a trip of two weeks which will include New York, Philadelphia and Washington, Mr. and Mrs. Watts will take up their resi-

dence at 222½ Borden Ave., Syracuse. Mr. Watts is a popular and progressive young business man, and his many friends in the trade extend hearty congratulations.

The regular monthly meeting of the New York State Association of Opticians will be held at their rooms, 501 and 503 Dillaye building, on Nov. 15, at 1 o'clock p. m., and artistic cards announcing the programme and other items of interest have been received by the members. Beginning with November a series of papers has been arranged for each meeting, which will be of especial practical value to the members. Following is the programme for the November meeting: "Accommodation and Convergences," G. N. Luckey, of Baldwinsville; "Hypermetropia," G. M. Babbitt, of Syracuse; "Dioprics and Catoptics," F. Hamilton, of Syracuse.

A mattress in the rooms of William T. Gardner, jeweler, Paterson, N. J., and the leading candidate for Assembly on the American Democratic ticket, took fire last Tuesday night. How it started was a mystery that the owner of the store could not explain, as he said that there were no matches about the room and nobody home.

**Notes from Near and Far.**

George B. Chase, Le Roy, Ill., is out of business.

J. A. Covalt, Bedford, Pa., is out of business.

George Carleton, Danforth, Me., is out of business.

Isaac B. Fass, New Orleans, La., has suspended payments.

A. E. Foster recently succeeded I. B. Frazee, Blairstown, Ia.

H. Matlock's jewelry store suffered by a fire in Turner, Mich., last week.

C. O. Heyerdahl has removed from Lake Park, Minn., to Kenyon, Minn.

Miss K. Bergstrom, formerly engraver at Hight & Fairfield's, Anaconda, Mont., has left for Seattle, Wash., where she will enter one of the jewelry stores in a similar capacity.

S. O. Huseuth, who was in the jewelry business in Madison, Wis., last Spring, has just purchased a stock of goods in Park River, N. D., and will enter into business at that point.

B. M. Jenney, jeweler, who has been in the drug business in Weiser, Idaho, for many years, has sold his store to Roscoe W. Smith, of Mountain Home. Mr. Jenney will continue in the watchmaking business there.

# Troubles of Your Own?

**SHORT of WATCHES, FOR  
INSTANCE? Ladies' Watches in  
particular.**

## Elgins, Walthams,

and dainty cases for them.

Of course, just now movements and cases go  
together.

Quite likely we can help you out.

We are still at the corner of  
Broadway and Dey St., New York.

**C. G. ALFORD & COMPANY.**

November 15, 1899.

# TO RETAIL JEWELERS, WARNING

## Keep Tabs on the Tags and Swivels.

When you buy Blackinton Chains the stamps on swivels tell the story.

EACH TAG AND STAMP ON SWIVEL REPRESENTS A DIFFERENT QUALITY.



OLD RELIABLE  
**W. & S. B. ★ GLOBE FILLED**  
 ARE EXTRA QUALITY  
 AND WARRANTED TO ASSAY  $\frac{1}{8}$  GOLD.

OUR REGULAR  
**OLD RELIABLE W. & S. B. ★**  
 ARE  $\frac{1}{10}$  PLATE AND SUCH AS WE  
 HAVE MADE FOR 30 YEARS.

IF YOUR SWIVELS BEAR EITHER OF THE ABOVE TWO STAMPS YOU ARE SURE OF GETTING CHAINS THAT EXCEL IN

### QUALITY, DESIGN AND FINISH,

THE GREATEST OF VIRTUES THAT COMBINE TO MAKE A LINE OF GOODS

### RELIABLE AND SALABLE.

EVERY JOBBER CARRIES THESE CHAINS. INSIST ON SEEING THEM; A CAREFUL EXAMINATION WILL PROVE THE ABOVE.

Tr  
Thi  
Fa



MR. W. SUMNER BLACKINTON EXPLAINING THE DIFFERENT QUALITIES AS INDICATED BY THE STAMP ON THE TAGS AND ON THE GOODS.

QUALITY.



**Each Article of this Grade  
is Stamped as above.**

**THIS IS  
OUR 2d QUALITY.**

**CAUTION**

Retailers when buying should be most careful to see that chains so stamped are not sold as either the old reliable W. & S. B. ★ GLOBE FILLED or the old reliable W. & S. B. ★. **THIS IS BEING DONE AND HAS BEEN DONE EXTENSIVELY.**

SECOND QUALITY.



Trade

Mark.

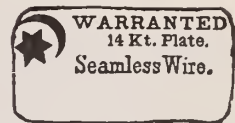

This Tag goes with this Swivel.

Mark.

Bellable.  
& S.B.★  
Seamless Wire.

with this Swivel.

**W. & S. BLACKINTON.**

Providence, R. I.

New York, 14 Maiden Lane.

# A Few Queries for the Jeweler.

**Why not** place in your stock of Silver Ware only those goods that have a **fashionable reputation** with your wealthy patrons?

**Why not** confine your purchases to houses who deal only with Jewelers, thus preserving an exclusive character to the wares in your stock not possible with goods illustrated in Dry Goods Catalogues, and identical with stocks carried by your Department Store competitor?

**Your Silver Wares** are bought for fashionable occasions, and your customers will appreciate your efforts to supply only goods of an exclusive character.

**Sterling Silver Goods sold to Department Stores** should have no place in any first-class Jeweler's stock.

**Sterling Silver Goods illustrated in Dry Goods** Catalogues and circulars are not suited to the fashionable trade.

**Sterling Silver Goods** of an exclusive character are sought for by persons of refinement desiring to make a wedding anniversary or birthday gift.

**Sterling Silver Goods** made by the Gorham Mfg. Co. are sold **only through the Jewelry trade**, and are stamped with the Lion, Anchor and the letter "G," insuring quality.



## Gorham Mfg. Co.,

...SILVERSMITHS...

Broadway and  
19th Street,      "      New York.

BRANCHES:

NEW YORK:  
21 & 23 Maiden Lane.

CHICAGO:  
131-137 Wabash Avenue.

SAN FRANCISCO:  
118-120 Sutter Street.

WORKS: PROVIDENCE, R. I., AND NEW YORK CITY.

# The Jewelers' Circular

AND  
HOROLOGICAL REVIEW.

PUBLISHED EVERY WEDNESDAY BY  
**THE JEWELERS' CIRCULAR PUB'G CO.,**  
CORBIN BUILDING, 11 JOHN ST., COR. BROADWAY,  
NEW YORK.

TELEPHONE:  
1148 CORTLANDT.

CABLE ADDRESS:  
JEWELAR, NEW YORK.

A JOURNAL DEVOTED TO THE INTERESTS OF JEWELERS,  
WATCHMAKERS, SILVERSMITHS, ELECTRO-PLATE MANU-  
FACTURERS, AND ALL ENGAGED IN KINDRED BRANCHES OF  
INDUSTRY.

Member of the American Trade Press Association.

Our editorial columns will contain our own opinions only, and we shall present in other columns only what we consider of interest or value to our readers. Advertising matter will not be printed as news.

Advertising rates in THE CIRCULAR are lower, considering the number of tradesmen reached by its large circulation, than in any other jewelry journal.

Notices of changes in standing advertisements must be received one week in advance; new matter can be received up to Monday.

## INFORMATION FOR SUBSCRIBERS.

### Terms of Subscription, Postage Prepaid.

	PER ANNUM.
United States and Canada, - - -	\$2.00
Foreign Countries in Postal Union, - - -	4.00
Single Copies, - - - - -	.10

New Subscribers can commence at any time.

Payments for THE CIRCULAR, when sent by mail, should be made in a Post-Office Money Order, Bank Check or Draft, or an Express Money Order or Registered Letter. All postmasters are required to register letters whenever requested to do so.

Pay money only to authorized collectors having proper credentials.

**Returning Copies.** Returning your paper will not enable us to discontinue it, as we cannot find your name on our books unless your address is given.

**Changing Address.** In changing address always give the old as well as the new one. Your name cannot be found on our books unless this is done.

**Discontinuances.** We will continue to send papers until there is a specific order to stop, in connection with which all arrearages must be paid; but such an order can be given at any time, to take effect at or after the expiration of the subscription. All such orders will be promptly acknowledged by mail.

**Liability.** The courts have decided that all subscribers to journals are responsible until arrearages are paid in full and an order to discontinue has been received by the publisher.

### THE JEWELERS' CIRCULAR IN EUROPE.

Among the places in Europe where THE JEWELERS' CIRCULAR is on file are the following:

**LONDON**—First Ave. Hotel, Holborn, E. C.; Holborn Viaduct Hotel, Royal Hotel.

**PARIS**—Hotel de L'Athene, Rue Scribe.

**LEIPZIG**—Handels-Zeitung, für die gesamte Uhren-Industrie.

**BERLIN**—Deutsche Uhrmacher Zeitung, Jäger-Strasse, 73.

**GENEVA**—Journal Suisse D'Horlogerie.

**AMSTERDAM**—Continental Club, Hotel Amstel.

**ANTWERP**—Diamond Club, Rue de Pelican.

Vol. XXXIX. Nov. 15, 1899. No. 16.

Every line of reading matter in THE JEWELERS' CIRCULAR, with the exception of the few brief extracts from exchanges, always properly credited, is written exclusively for this journal. Each issue of THE JEWELERS' CIRCULAR is copyrighted. Permission to quote is extended to other publications provided such quotations are properly credited.

### Retail Jewelers on Watch Case Guarantees.

WITH this issue of THE CIRCULAR we start a symposium of the retail jewelers upon a most important matter bearing upon their business interests, namely, the guarantees accompanying gold filled watch cases. The prompt and hearty response to THE CIRCULAR's letter of questions, and the numerous instances of elaborate and in every instance careful consideration of the subject by the respondents, are evidence that the matter is of living interest to the trade, and that an early solution of the problem of the future—for the approaching accumulative maturing of the long life guarantees, with the likelihood that a percentage of the number of cases in use will show signs of wear sufficient to warrant the user, in his own mind, to demand new cases for the old ones, constitutes a problem—will redound to the advantage of the trade as a whole and of the manufacturers in particular. The retail jewelers are the persons principally concerned in this question, and the consensus of their ideas and opinions bearing upon it will prove a guide to the manufacturers for the future. Up to the present time the question has given no considerable trouble, but with the increasing competition of the times and the tendency to advance guarantees, the manufacturers must place their policy clearly before the trade. This series of letters will cover several issues of THE CIRCULAR; until they are concluded we will suspend our judgment of the preponderant expression of opinion.

### A Loophole for Diamond Smuggling.

THE framers of the present tariff law showed wisdom in the providing for the return under certain conditions without imposition of duty, of articles of United States manufacture after they had been exported. They showed even profounder wisdom in demanding that "proof of the identity of such articles shall be made under general regulations to be prescribed by the Secretary of the Treasury." The first provision allows the exploitation of protected manufactures in foreign lands, while the second is designed to prevent smuggling of foreign goods in the guise of American manufactures. The recent detention by the Collector of the Port of New York of a quantity of cut diamonds, a portion of which is undoubtedly of American cut but which was exported and then imported without complying with the regulations of the Treasury Department, will provide the Government with an opportunity to test the section of the law embodying the provision referred to. Those parts of Section 483 in the free list bearing upon the case referred to are as follows:

"483—Articles, the growth, produce and manufacture of the United States, when returned after having been exported, without having been advanced in value or improved in condition by any process of manufacture or other means . . . but proof of the identity of such articles shall be made, under general regulations to be prescribed by the Secretary of the Treasury. . . ."

Without entering into the merits of the

To insure publication in the following issue, order for space for NEW advertisements must be received not later than Monday noon.

individual case at issue, it is to be earnestly hoped that measures will be taken by the Treasury Department to provide, by proper regulations, safeguards against the possible smuggling that is opened by this section. Every diamond and gem proposed to be taken out of the United States should be described in every particular, and this description entered in proper records provided for this purpose; for, if any broad identification, such as gross weight of package of stones, is permitted, the unscrupulous need not take the package out of the country at all, but need only supply themselves on the other side with a package of exactly the same weight, and thus save the 10 per cent duty. It is a practical impossibility to duplicate the individual stones as to exact weight, size, color and other characteristics, but it is comparatively easy to duplicate the weight of a package and the general character of its contents.

### Sharp Rises in the Market Price of Bar Silver.

The market for bar silver has been subject to an unusual fluctuation during the past week. The London quotation was advanced 3-16d. Nov. 8 over the price of the day before, and Nov. 9 silver was advanced 3-16d. more, making a total advance of 3/4d. an ounce in two days. The quotation for New York Nov. 9 was 59-60, an advance of nearly 3/4 cent per ounce, and certificates sold at 60.

The opinions given by two silver houses were to the effect that the advance was caused by an unusually strong demand for the metal from Hong Kong and Shanghai and from Indian buying sources. It was not believed that the European banks were seeking silver.

The prices Monday were: New York, 59c. per ounce; London, 27 1/4d. per ounce.

### Regarding Signing Extension and Compromise Papers.

At the regular monthly meeting of the directors of the Jewelers' Association and Board of Trade, held Nov. 9, 1899, they discussed the practice of members signing general extension or compromise papers as presented by debtors, of which no record was afterwards accessible except through application to the debtor. As it was deemed advisable that the organization should have on file for the use of its members all the facts in such cases, the following resolutions were unanimously adopted:

*Resolved*, That the members be requested to refrain from signing any paper of compromise or settlement presented to them by a dealer unless said paper bear a certificate of this Corporation that the debtor has filed with the Corporation a full statement of his affairs showing names of creditors, the amount owing each, his assets and liabilities, etc.

*Resolved*, That a copy of these resolutions be sent to each member of the Corporation.

## BUYERS' INFORMATION BUREAU.

Questions as to the makers of certain lines of goods, where to buy certain lines, where certain kinds of work are done, the owners of certain trade-marks and other matters relating to the buying branch of a jewelry business will be cheerfully answered under this department. The reader cannot ask too many questions.

ATLANTA, Ga., Nov. 7, 1899.

Editor of THE JEWELERS' CIRCULAR:

Can you inform us who makes the silver chain purse with a stationary top and flat lid? We don't think we have seen it illustrated in any of the catalogues, but can find plenty of the gate top style and those with the ball fastening. Thanking you in advance, we are,

Very truly yours,

JULIUS R. WATTS & Co.

ANSWER:—Such goods can be obtained from Carter, Hastings & Howe, 9-13 Maiden Lane; A. Wallach & Co., 37-39 Maiden Lane; Coddling & Heilborn Co., 13 Maiden Lane, New York.

WILMINGTON, Del., Nov. 3, 1899.

Editor of THE JEWELERS' CIRCULAR:

We have been referred to you as being able to tell us where we could get a gun metal gent's watch chain in bead design, as we have been unable to procure one as yet, although we have tried several firms. By giving the desired information you will greatly oblige,

Yours truly,

M. F. DAVIS.

ANSWER:—J. N. Provenzano, 114 E. 14th St., New York, makes these goods.

FRANKLIN, Pa., Nov. 11, 1899.

Editor of THE JEWELERS' CIRCULAR:

Will you kindly advise us through your columns what is the address of Payton & Kelley, chain makers, and oblige,

Yours respectfully,

B. J. FELDMAN'S SONS.

ANSWER:—118 Richmond St., Providence, R. I.

## A Watch that Played a Part in American History.

CHARLES A. FRICKER, of James Fricker & Bro. (Inc.), Americus, Ga., who recently visited THE CIRCULAR office, exhibited an interesting timepiece, whose story is set forth in the three engraved inscriptions in the case as appended:

*Inside of the Front.*

Worn by Gen. Cobb while President Provisional Congress and when he administered the oath to Jefferson Davis as President of the Confederate States and while Maj.-General in the Confederate States Army.

General Howell Cobb died Oct. 9, 1868.

*On the Inside Back.*

Howell Cobb, Sect'y of the Treasury, U. S., on his 45th Birthday from his wife, Mary Ann Cobb, Washington, D. C., Sept. 7, 1860.

*On the Cap.*

Presented to John A. Cobb by his mother, Mary Ann Cobb, on his 30th birthday, Athens, Ga.

## Trade-Mark Information.

Note.—The publication of our work, "Trade-Marks of the Jewelry and Kindred Trades," containing over 2,250 marks, all told, the accumulation of various works of reference and the ramifications of our business enable us to trace to their origin nearly all marks that may be found on jewelry, silver ware, art pottery and kindred lines, of both American and foreign make. All questions in regard to trade-marks will be cheerfully answered. We would be pleased to have the trade seek the benefit of our facilities regarding the identity of any marks they cannot trace. We would prefer to receive the article for examination; for if the mark is of foreign origin, the slightest difference between a drawing and the original is of great importance.

No question is too trivial nor too complicated for consideration under this department.

LANCASTER, Pa., Oct. 27, 1899.

Editor of THE JEWELERS' CIRCULAR:

I have a copy of your "Trade-Marks of the Jewelry and Kindred Trades," but am not able



to find this jewelry manufacturer's mark. Please let me hear from you. Yours respectfully,

T. WILSON DUBBS.

ANSWER:—This is the trade-mark of Charles M. Robbins, Attleboro, Mass., adopted since our work was published.

MARQUETTE, Mich., Nov. 2, 1899.

Editor of THE JEWELERS' CIRCULAR:

We are sending you this mail ebony handle sterling wax dipper, showing trade-mark, which we are unable to find in your "Trade-Marks,"

STERLING



November, 1898, supplement. Kindly inform us whose make this is. Yours truly,

GEO. N. CONKLIN.

ANSWER:—The trade-mark stamped on the article is that of John W. Reddall & Co., 54 McWhorter St., Newark, N. J. It is illustrated on page 16 of "Trade-Marks of the Jewelry and Kindred Trades," published by The Jewelers' Circular Pub. Co.

RUTLAND, Vt., Nov. 4, 1899.

Editor of THE JEWELERS' CIRCULAR:

Please give me the address of the parties making or selling plated ware with the name:

CONNECTICUT PLATE CO.

Yours very truly,

L. M. S. W.

ANSWER:—This name is used by J. W. Johnson, 22 John St., New York. See page 55 of "Trade-Marks of the Jewelry and Kindred Trades," published by The Jewelers' Circular Pub. Co.

A party brought to THE CIRCULAR office a spoon of old design bearing the stamp,

W. G. & S.

and desired the name of its maker.

ANSWER:—These initials were the stamp of William Gale & Son, who were in business 30 and more years ago and who were in 1870 succeeded by the present firm of Dominick & Haff, 860 Broadway, New York. William Gale & Son stamped the date on their goods, and their successors follow this practice. The spoon under consideration was stamped with the date 1856.

## ON MEMORANDUM

You'll have all kinds of stockings to cater to in the next few weeks, and nowhere will you get such an assortment of Diamonds and Diamond Jewelry as we can send you; but they won't last long in view of the rising market. Don't forget that our goods were bought months ago, and, notwithstanding the rises, will be sold at nearly the old prices, while they last. Anything you want—loose or mounted—"On Memo."

V. WARING, N.Y.

## CROSS &amp; BEGUELIN

Importers and Cutters of Diamonds and Precious Stones

43 Rue de Meslay, PARIS

17 Maiden Lane, NEW YORK



**New York Notes.**

The Bryant Jewelry Co. have started in business to sell jewelry on instalments at 66 Nassau St. J. F. Bryant is the general manager of the concern.

The Sheriff last week sold out the effects of the Majestic Silver Co., manufacturers of plated ware, 290 Pearl St., for \$800. The sale was on the executions which were published in THE CIRCULAR two weeks ago.

Creditors of the defunct Johnston Jewelry Co. are cited to appear in Part I. Special Term of the Supreme Court, Dec. 18, at 10.30 o'clock A. M., and show cause why a final settlement of the accounts of Henry A. Kirby, as assignee of the company, should not be had.

On Nov. 13, Monroe B. Bryant, of M. B. Bryant & Co., 10 Maiden Lane, completed his 50th year as a manufacturer of rings. Mr. Bryant is now 75 years of age. He founded the firm of Bryant & Bentley, the predecessors of M. B. Bryant & Co., in 1859.

A handsome loving cup was presented Thursday to Chas. T. Root, of the *Dry Goods Economist*, by the members of the editorial staff of that journal, on the occasion of Mr. Root's 50th birthday. The mechanical force of the paper also presented to him a magnificent silver salver, 18 inches in diameter.

Mrs. T. Lynch has entered an appearance by counsel in the action noted in THE CIRCULAR, Oct. 25, which was brought in the United States Circuit Court by Jean Baptiste Baillie, of Paris, to restrain her from using the name Le Maire on opera glasses not made by the complainant. No answer to the suit has yet been filed.

The Mount Morris bank has entered a judgment for \$5,059.02 against B. & W. B. Smith. The first meeting of the creditors of Jacob W. and W. B. Smith, composing the firm of B. & W. B. Smith, who filed a petition in bankruptcy Oct. 31, has been called for Nov. 20, at 11 o'clock A. M., and will be held at the office of Geo. C. Holt, referee in bankruptcy, 34 Pine St.

At the regular monthly meeting of the board of directors of the Jewelers' Association and Board of Trade, held Thursday, the following firms were unanimously elected members: The C. F. Monroe Co., Meriden, Conn.; Robert Beygeh & Bro., Chicago, Ill.; J. W. Forsinger, Chicago, Ill.; Madson & Buck Co., Chicago, Ill.; Western Clock Mfg. Co., La Salle, Ill.; Freudenheim Bros. & Levy, New

York, and Charles S. Crossman & Co., New York.

An order of Judge Lacombe, of the United States Circuit Court, last week, again extended the time of Ed. Cane and S. A. Lehman in which to put in their answer to the suit brought against them by the International Silver Co. This is the action in which, as already noted in THE CIRCULAR, the defendants, who are auctioneers, were restrained from using signs to the effect that they were closing out the stocks of Simpson, Hall, Miller & Co. and Rogers & Brother.

Among the creditors of Wm. Clark Noble, a sculptor, who filed a petition in bankruptcy Friday, are the Gorham Mfg. Co., to whom the schedules say is due \$21,077 for money loaned to Noble between Aug. 12, 1893, and Sept. 16, 1899. The indebtedness to the Gorham Mfg. Co., as noted, is not, however, as large as it would here seem, as the amount given is materially offset by drawings and designs made by Noble and held by the company, on which advances were made.

Before Judge Scott, in the Supreme Court last week, application was made by Franklin Bien for the voluntary dissolution of L. Tannenbaum & Co. Corporation, dealers in diamonds at 52 Nassau St. Edward L. Davis was appointed referee in the matter. The proceedings are merely a legal formality, as the corporation sold its business on June 8 back to Lippman Tannenbaum, who assumed the debts, and the capital stock was surrendered to the corporation and canceled. The company had done no business since June 8; has no assets and no liabilities. It was organized by Lippman Tannenbaum on Sept. 24, 1896, and had a capital stock of \$500,000. The firm of L. Tannenbaum & Co. are doing business as usual.

Edward Le Coulter, said to be a rich watchmaker from France, who left his wife and children and eloped to this country with Julia Kurtz, was last week excluded by the Board of Special Inquiry at the Barge Office, and he and his companion were held for deportation. The couple arrived here on *La Champagne*. In some way it became noised abroad that the couple were not man and wife, so when they arrived at this port they were taken to the Barge Office and the Board of Inquiry began an investigation. Le Coulter confessed to having left his wife and children in France to come to America with the Kurtz woman. They were on their way to Los Angeles, Cal., where they intended to live.

# Cut Glass.

BEST STYLES,  
LATEST IDEAS,  
LARGEST STOCK.

**C. DORFLINGER & SONS,**

36 Murray Street  
and 915 Broadway,

NEW YORK.

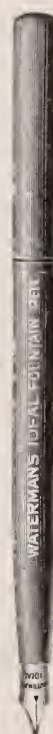

## The Fountain of Specialty Satisfaction.

You have no specialty that commands a more ready sale—that gives more satisfaction to buyer and seller—than

## Waterman's Ideal Fountain Pen.

But to reap your advantage to the full, carry a full stock of our ornamental styles.

**L. E. Waterman Co.,**  
155-157 Broadway, = New York.

Largest Manufacturers of Fountain Pens in the World.

1851.

1899.

# THE CHATHAM NATIONAL BANK, NEW YORK.

CAPITAL STOCK, - - - - \$450,000  
UNDIVIDED PROFITS, - - - - 974,518

GEO. M. HARD, President.

H. P. DOREMUS, Cashier.

W. H. STRAWN, Ass't Cashier.

H. L. Ward has entered a judgment for \$224.48 against Obadiah L. Sypher.

Otto Treibs, of Treibs Bros., New York, sailed for Europe last week on the *Lahn*.

John F. Faber, formerly with Ludeke & Power, is now city salesman for Albert Wild.

P. Marks has entered judgment for

\$121.35 against M. Eugene Hemminger.

Theresa Lynch has satisfied a judgment for \$6,280.15 entered by S. S. Jones on May 29, 1899.

The City of New York has entered a judgment for \$259.15 against the American Watchman's Time Detector Co.



American Gun Metal, Loaded with American Lead. Every Customer buys one to 1-2 doz. You want a gross at \$18.00.

#### AMERICAN GUN-METAL, NON-MAGNETIC WATCH CASES,

fitted with special American movements. Also U. S. Battleship "Maine" cases, advertised in leading magazines at \$5.00 to \$15.00 each, cost you \$24.00 doz.; ladies' size, \$27.00 doz. Order now to insure delivery.

#### AMERICAN GUN-METAL VEST CHAINS,

small, plain, neat patterns on attractive chain pads, advertised to sell at \$1.00 each. You want sample dozen at \$4.50. Ladies' Guard Chains at \$6.00 doz., retail at \$2.00 each.

Only a limited number can be made. Many will be disappointed on account of not being able to get samples.

W. F. DOLL MFG. CO.,

9-13 Maiden Lane,

New York.

NAVY YARD, NEW YORK.

June 23d, 1899.

This certifies that W. F. Doll Manufacturing Company purchased from the Government at public sale on the 9th of June, 1899, four (4) breech-loading 30 pdr. rifles, Nos. 17, 41, 121 and 126—weighing 13,600 pounds.

W. C. GIBSON, Commander, U. S. Navy, in charge delivery stores sold at Public Sale.

**"By Using Our Goods Your Goods Will Sell."**

## We Always Lead

With Something New and Artistic for Manufacturing Jewelers.

**OUR FINDINGS SPEAK FOR THEMSELVES**

Call or Send for Samples of

## OUR LATEST

**And Keep Your Trade Guessing What You Will Show Them Next.**

We are now showing a handsome and complete line of

**MEDALLIONS AND EBONY MOUNTS.**

# HEIMBERGER & LIND,

158 PINE ST., METCALF BUILDING, PROVIDENCE, R. I.

The Central Pen and Manufacturing Co., of New York, have been incorporated to manufacture fountain pens, with a capital of \$10,000. B. H. Rosenblatt, Harry Leloneck and William M. Rosebault, of New York, are the directors.

Before Judge Fitzgerald, in the Supreme Court, last week, L. & M. Kahn & Co. were allowed a judgment for \$2,391.48 against Chas. Casper and Letitia Casper. The suit was brought on promissory notes by Casper and endorsed by his wife, given for merchandise sold.

George M. Lynch, son of Mrs. T. Lynch, 1 and 3 Union Sq., Friday filed a petition in bankruptcy, with liabilities of \$16,854 and no assets. There are 73 creditors, and the debts were contracted between 1894 and 1899. They are principally for merchandise and advertising. He owes the city for taxes \$1,079.

Alphonse Gallo and Michael Gallo, formerly of the firm of Gallo Bros. & Volpe, who filed a petition in bankruptcy, have applied to the United States District Court to be discharged of all their debts. Creditors are notified to attend the hearing on this application before Judge Brown, Wednesday next at 10.30 o'clock A. M.

Bernard and Meyer Hecht, formerly of Hecht Bros., who some time ago filed petitions in bankruptcy, have applied for a discharge of all their debts. Creditors are notified that a hearing on this application for the discharge of their debts will be had before Judge Brown in the United States District Court, Dec. 6, at 10.30 o'clock A. M.

As noted in THE CIRCULAR, Nov. 1, Clara Montague, the executrix of the late Henry E. Droz, appealed to the Appellate Division of the Supreme Court from an order obtained by Mrs. Rachael Flint, making her a party defendant in the action brought by Mrs. Montague against the Jewelers' and Tradesmen's Co. Droz was, before his death, an old and well known importer and jobber of watches, and the action was over insurance on his life. The Appellate Division of the Supreme Court, Friday, handed down a decision affirming, with \$10 costs and disbursements, the order appealed from.

Judge Scott, of the Supreme Court, Monday appointed Everett B. Heyman receiver in supplementary proceedings for John Foley, gold pen manufacturer, of 5 Dey St., on the application of Joseph R. Jackson, a judgment creditor for \$4,098. Mr. Foley stated in his examination that he was not in any business. His wife, Elma, is conducting the business at 5 Dey St., but he is about the place a great part of the time. He has some jewelry, consisting of a gold watch, \$10; two California diamond studs, which cost \$1, and a pair of gold cuff buttons. In the past two years he has paid off \$10,000 to \$15,000 of his debts.

A well dressed young man entered Jas. McMurray's jewelry store, 478 Main St., Paterson, N. J., last week, and asked to see a watch. His appearance was respectable and McMurray placed a fine time-piece on the counter. The young man seized it and dashed from the store. Mr. McMurray gave chase, but the thief escaped. The police are now looking for him.

# Special Notices.

## Situations Wanted.

**DIE SINKER** wants a situation; accustomed to all kinds of die work and tool making. Address V. M. C., 315 Washington St., Brooklyn, N. Y.

**WANTED**—Fine gold jewelry stock to sell on commission in New York and other cities with diamond mounting line; fine trade. "Platina," care Jewelers' Circular.

**EXPERIENCED MAN** who can superintend and design; understands the manufacturing of jewelry in all its branches; good references. Address "Expert," care Jewelers' Circular.

**PRACTICAL DESIGNER**, with 15 years' experience in all branches of sterling silver ware, desires position; A1 references furnished. Address "Sterling," care Jewelers' Circular.

**SALESMAN**, having 15 years' experience in jewelry and silverware lines, is open for an engagement with manufacturer for 1900; well acquainted with trade; Eastern to Middle Western States; excellent references. Address "Ilustler," care Jewelers' Circular.

**AN OPTICIAN**, watchmaker and engraver wants a steady position with a good firm; understands the business thoroughly; young man, single, sober and steady; have tools and trial case; state salary in first letter; A1 references. Address "Optician," care Jewelers' Circular.

## Help Wanted.

**WANTED**—Salesman for southern and southwestern trade. Zimmern, Rees & Co., 9-13 Maiden Lane, New York.

**WANTED**—An experienced designer on sterling silver hollow ware and novelties. Address "Silversmith," care Jewelers' Circular.

**ABRAHAM & STRAUS**, Brooklyn, N. Y., require at once a thoroughly competent watch repairer; permanent position and good salary to the right party.

**WANTED**—A good watchmaker, jeweler and engraver; must have good references; permanent position to right man. Chas. F. Billau, Cedar Rapids, Ia.

**WANTED**—A good watchmaker and engraver; must be competent; permanent position to right party; wages according to ability and capacity. P. W. T., care Jewelers' Circular.

**WANTED**—A watchmaker, with full set of tools; one who can engrave preferred, with references; salary \$12; permanent position for right man. Address E. R., care Jewelers' Circular.

**WATCHMAKER**, jeweler, engraver, all around man; send sample of engraving, wages wanted, reference, photo, how long at business and full particulars in first letter; steady job for right party. J. F. Butler, Potsdam, N. Y.

**WANTED AT ONCE**, an expert jeweler, diamond setter and engraver; \$22 per week, fare to Little Rock and permanent position to right man. Address, with full particulars and reference with first reply. Albert Pfeifer, Little Rock, Ark.

**A FIRM** manufacturing sterling silver hollow ware exclusively for the legitimate jewelry trade wants a general designer who is thoroughly competent and experienced in the line; answers strictly confidential. Address "Silver," care Jewelers' Circular.

**WANTED** at once, a young man to repair jewelry, all kinds of clocks and do plain script engraving; position permanent; state wages wanted and send references and sample of engraving with first letter. Address "Jeweler and Engraver," care Jewelers' Circular.

**WANTED**—Salesman, capable, young, energetic, experienced, for the northwest, by live jewelry and novelty house; good salary; must have best of references and clean record; acquaintance with trade preferable; give full information and references in first letter. "American," care Jewelers' Circular.

**WANTED**—Watchmaker, jeweler and engraver, single man preferred; all around helper, with tools; \$12 per week; send sample of engraving, references and photograph in first letter; give full particulars; this is a steady job for right party; good store, nice town, in New York State; board and room cost \$3.50 to \$4 per week. Address "Jeweler," care Jewelers' Circular.

## Business Opportunities.

**FOR 30 DAYS** I offer my jewelry business, or fixtures only, at a very low price; I have been established 35 years. Wm. F. Wallace, Westerly, R. I.

# INDEX TO ADVERTISEMENTS.

Aikin, Lambert & Co.....	55	Kohn & Co.....	22
Aikin, Lambert Jewelry Co.....	55	Kohn, Alois, & Co.....	54
Alford, C. G., & Co.....	27	Kroeber, F., Clock Co.....	52
American Watch Case Co.....	55	Lady Racine.....	36
American Waltham Watch Co.....	17	Le Boutillier & Co.....	56
Arnsstein Bros. & Co.....	56	Lederer, S. & B., Co.....	56
Austin, John, & Son.....	56	Ledos Mfg. Co.....	47
Avery & Brown.....	14	Lewis, Fred W., & Co.....	19
Ball, Wm. H., & Co.....	47	Levy, L. W., & Co.....	43
Bassett Jewelry Co.....	47	Leys, Christie & Co.....	22
Bell Watch Case Co.....	15	Lind, Thomas W.....	57
Billings, Chester, & Son.....	19	Malliet, C. G., & Co.....	19
Blackinton, W. & S.....	28	Mathews & Prior.....	47
Bowden, J. B., & Co.....	18	Mauran, John T., Mfg. Co.....	41
Bradley Polytechnic Institute.....	56	Mathey Bros., Mathez & Co.....	38
Bradley & Hubbard Co.....	52	Mausier Mfg. Co.....	8
Bryant, M. B., & Co.....	50	Mercantile National Bank.....	46
Charham National Bank.....	33	Mount & Woodhull.....	18
Clark & Coombs.....	55	Myers, S. F., Co.....	54
Conley & Straight.....	56	New England Watch Co.....	23
Cook, Edward N.....	56	Noble, F. H., & Co.....	41
Cross & Bequelin.....	32	Omega Watches.....	14
Crossman, Charles S., & Co.....	14	Oppenheimer Bros. & Veith.....	19
Crouch & Fitzgerald.....	52	Pairpoint Mfg. Co.....	54
Day, Clark & Co.....	56	Palmtag, Jacob.....	43
Deutsch Bros.....	5	Philadelphia College of Horology.....	47
Delaware Ophthalmic College.....	48	Providence Stock Co.....	56
Doll, Wm. F., Mfg. Co.....	34	Reichhelm, E. P., & Co.....	38
Dorflinger, C. & Sons.....	33	Reisner, L. C., & Co.....	3
Dubois Watch Case Co.....	51	Remington Typewriters.....	52
Dueber-Hampden Co.....	13	Rich, H., & Co.....	47
Eaton & Glover.....	54	Robert, E. E.....	16
Eisenmann Bros.....	20	Roy Watch Case Co.....	43
Eliassof Bros. & Co.....	50	Rumpp, C. F., & Sons.....	38
Esser & Barry.....	55	Saunders, John F.....	19
Fahys, Jos., & Co.....	45	Schulz & Rudolph.....	18
Fairchild & Johnson Co.....	56	Selwyn Importing and Trading Co.....	43
Field & Beattie.....	38	Sherwood, John W., & Co.....	12
Foster, Theodore W., & Bro. Co.....	2	Simmons, R. F., & Co.....	47
Fox & Co.....	18	Simmons & Payne.....	16
Frankel's Sons, Jos.....	15	Simons, Bro. & Co.....	26
Freund, Henry, & Bro.....	38	Smith, Alfred H., & Co.....	20
Friedlander, R., L. & M.....	56	Stern Bros. & Co.....	51
Fuchs, Ferd., & Bros.....	55	Sternau, S., & Co.....	24
Goodfriend Bros.....	36	Strasburger, Byron L., & Co.....	22
Goodnow & Jenks.....	2	Street, Geo. O., & Sons.....	50
Gorham Mfg. Co.....	30	Sussfeld, Lorsch & Co.....	48
Gregory, F. J.....	43	Towle Mfg. Co.....	41
Harris & Harrington.....	56	Treibs Bros.....	24
Hayden Mfg. Co.....	39	Trenton Watch Co.....	16
Hedges, Wm. S., & Co.....	18	Wallace, R., & Sons, Mfg. Co.....	6
Heimberger & Lind.....	34	Waterman, L. E., Co.....	33
Howard Sterling Co.....	10	Westphal, W. C. A.....	55
Iraba, Louis W.....	52	Wheeler, Hawden W., & Co.....	21
Jacot & Son.....	55	Whiting, F. M., & Co.....	8
Juergensen, Jules.....	18	Wittnauer, A.....	11
Kahn, L. & M., & Co.....	56	Wood, Chas. F., & Co.....	56
Kendrick & Davis.....	51	Wood & Hughes.....	52
Knowles, Dr.....	47	Woods & Chatterlier.....	25
Knowles, J. B. & S. M., Co.....	9	Zurbrugg, T., Co.....	47

**AN EXCELLENT OPPORTUNITY**; an old-established jewelry store for sale, with or without stock; or store with fixtures; on account of death of the proprietor. Mrs. O. Zamow, 255 First Ave., New York.

**A BARGAIN**—For sale, an old estate and fine jewelry store, with complete stock and fixtures, in a good manufacturing town in the vicinity of New York; only \$2,800. Address U. B., care Jewelers' Circular.

**FOR SALE**—Stock of jewelry in a good mining town of 6,000 inhabitants; stock will inventory about \$2,000; will sell cheap and take part payment, with mortgage for balance. Address W. H. Wildenberger, Forest City, Pa.

**JEWELRY STOCKS BOUGHT**—Retailers wishing to dispose of surplus or entire stock of diamonds, watches and jewelry can find quick, cash, strictly confidential buyer by addressing S. Marx, 22 Lispenard St., New York City.

## For Sale.

**FOR SALE**—3 8-ft. show cases, \$25 each; 1 5-ft. 6 in. show case, \$18; these cases are 16 in. high, 24 in. wide, black enamel wood, all plate glass, including mirrors; good condition; 1 oak wall case, 25 ft. long, 6 ft. high, 20 in. deep, 30x50 plate glass mirrors, all lined with black felt; double thick glass in lift sash; medium condition; \$50. The Ruddy Jewelry and Optical Co., 145 State St., New London, Conn.

## To Let.

**TO LET** for manufacturing purposes, upper floor N.W. corner Maiden Lane and Nassau St., 25x50 feet; elegant light; cheap rent; five H. P. electric motor now in operation; also work benches and fittings if desired; just the thing for manufacturing jeweler. Inquire of H. Kohlbusch, Sr., balance manufacturer, 59 Nassau St., New York.

## TO RENT in Silversmiths' Building, CHICAGO.

A fine office on Wabash Avenue front, with north and east light, 20 x 42 feet, adjoining the Gorham Mfg. Co.'s salesroom on the sixth floor. Most desirable location in the city. For terms apply to

**GORHAM MFG. CO.,**

Silversmiths' Building, CHICAGO.

## SALESMAN to travel south

wanted with an up-to-date line of medium price Solid Gold Jewelry (Diamond set, &c.), extensive line of Sterling Novelties and high-grade Gold-Filled Vest Chains, Lorgnette Chains, Dumb-bell Links and Brooches. Salary, \$2,000 and expenses. Don't answer this unless you have established trade south, and can furnish high-grade references.

Address with particulars, "WIDE AWAKE," Care of JEWELERS' CIRCULAR.

## OPPORTUNITY FOR DEPARTMENT.

An old established house, city of 100,000, large corner store, magnificent window display, prominent location, will rent 1,000 feet floor space for department, Antique Furniture, Art Engravings, Paintings, Artists' Material, etc., or for Staple China and Pottery. Good opening for either above lines, for upright and active manager with experience and capital. Address with reference, T. C. L., care SLOAN & Co., 21 Maiden Lane, New York.

**Proceedings of the Jewelers' Security Alliance.**

The regular monthly meeting of the executive committee of the Jewelers' Security Alliance was held on Nov. 10, the following being present: Chairman Butts, President Bowden, Treasurer Karsch, Secretary Noyes, and Messrs. Wood, Sloan and Stern, of the committee. The following new members were admitted to the Alliance: Tiffany Jewelry Co., Boston, Mass.; S. Rogers & Co., New York; Robert P. Kiep, Joliet, Ill.; Frederick W. Buse, Waterford, N. Y.; Louis Beckman, Kendalville, Ind.; G. M. Erhardt, New Haven, Conn.; W. R. Heinrich, New York; Sylvester Rhodes, Ulysses, Neb.; A. W. Voedisch, Aberdeen, S. Dak.; Harry Bullard, Wellsville, N. Y.;

Benjamin Sands, Cleveland, O.; R. Beygeh & Bro., Chicago, Ill.; Abraham Lipman, Chicago, Ill.; Western Watch Case Mfg. Co., Chicago, Ill.; Jensen Bros., Chicago, Ill.; Mrs. H. L. Smith, Columbus, O.; R. W. Wheeler, Penn Yan, N. Y.; E. E. Muller, Malone, N. Y.; L. Heller & Son, New York; Bailey & Plumb, Ogdensburg, N. Y.; Egermann & Son, Aurora, Ill.; Chas. Ham, Frankfort, Ind.; E. H. Overton, Westfield, N. Y.; A. F. Thompson, Adel, Ia.; A. G. Bedford, Ionia, Mich.; Chas. A. Davis, Fairmont, Neb.; Alsted-Kasten Co., Milwaukee, Wis.; Bucklin, Geisler & Emrath, Chicago, Ill.; Fred Scholer, Chicago, Ill.; Geo. D. Davidson, Jersey City, N. J.; Otto Mehrkens, Hackensack, N. J.; T. Ben Turnbaugh, Bloomfield, Mo.

**New York Jewelry Shops Affected by Fire.**

A fire broke out Saturday evening in the building at 64-66 John St., New York, which completely destroyed the factory of I. Sternseher, manufacturer of gold locket and diamond mountings at that address. The fire was discovered about 8.25 o'clock by the lieutenant of Engine Co. No. 32, who, on investigating the smoke coming from the building, turned in an alarm. The flames had made such headway, however, that by the time the engines arrived the fire could not be put out until after the interior of the building had been completely gutted. The only jewelers in the building beside Mr. Sternseher were Rabinowitz & Ratner, who had benches in his factory on the second floor, and William Park, stone and metal seal engraver, on the top floor. The loss to all these people is total. It is believed that the fire started in the lower part of the building and worked up by way of the stairs to the top floor.

**Gorham Mfg. Co. to Make the "Wisconsin" Silver Service.**

MILWAUKEE, Wis., Nov. 8.—Dr. J. C. Reynolds and Julius Bleyer, of the Wisconsin Battleship Commission, held a conference with the representatives of the Gorham Mfg. Co., of New York, last evening at the Hotel Pfister, in reference to the silver ware to be presented to the battleship *Wisconsin*. The Gorham company are to make the silver ware, under the contract awarded to the C. Preusser Jewelry Co., of this city.

The E. Howard Watch & Clock Co., 41 Maiden Lane, New York, are now installing for Wm. Wise & Son, jewelers, Fulton St. and Flatbush Ave., Brooklyn, a very magnificent post clock, with four dials, arranged for illumination. The dials measure 36 inches in diameter, and the post is 15 feet from base to center of dials. This clock will be very handsome when completed, and is to be an exact counterpart of the fine Howard clock now in front of the Philadelphia and Reading depot at Philadelphia. The same concern recently completed for M. Straus, jeweler, 409 Fulton St., Brooklyn, one of the finest striking post clocks in this country. The post is 12 feet from base to center of dials, and has four dials, 30 inches in diameter. These dials are illuminated at night, and the fine large sign above the dials is also illuminated. The hours are struck on a bell weighing 65 pounds, which is placed at the top of the post. The clock is run by an hour striking tower clock movement, which is located on the second floor, the shafting and striking connections being run in tubes down through the store, then under the sidewalk and up through the post. The company are doing a larger business in post clocks than for many years past, and have installed many during the past year, among them being the fine two dial post clock in front of S. N. Wood & Co.'s store, 740 Broadway, and the one in front of the jewelry store of I. Lewkowitz, 17th St. and Sixth Ave. This last clock has two dials 40 inches in diameter, with a post 15 feet from base to center of dial.

**THE LADY RACINE**

IS THE

**Best Chatelaine Watch**

10 Line,  
11 Line,  
12 Line,  
13 Line,  
Hunting or  
Open Face,



Nickel,  
Steel,  
Silver,  
Enameled,  
Gold,

**In new and tasty designs.**

Can be ordered from all Reliable Jobbers.

**Pearls**  
**Opals**

Importers and Cutters **GOODFRIEND BROS.,** Precious and Imitation Stones  
9-13 Maiden Lane, N. Y. 174 Weybosset St., Providence, R. I. 10 Rue Cadet, Paris.  
TELEPHONE, 662 CORTLANDT.



## Our Traveling Representatives

Traveling representatives may consider these columns open for the publication of any news or items of interest regarding themselves or their conferees.

R. L. Kintz, traveling salesman for E. G. Webster & Son, Chicago, has returned from a profitable trip through the west. H. E. King, representing the Knickerbocker Silver Co., was in Chicago last week. C. M. Stone is back in Chicago from a short trip in Michigan for Simpson, Hall, Miller & Co., which yielded good results.

Among the travelers in Kansas City, Mo., last week were: W. A. Bliss, E. A. Bliss Co.; Jno. O. Slemmons, J. B. Bowden & Co.; E. Lange, P. W. Lambert & Co.; Walter Strauss, Jacob Strauss & Sons; Thos. E. Rogers, Riker Bros.

The jewelers of Portland, Ore., were recently interviewed by the following traveling men: John L. Cunningham, Leys, Christie & Co., New York; Frank G. Moyer, American Watch Case Co., New York; W. A. Weichman, for Frank W. Smith, Gardner, Mass.; F. H. Ryland, LaPierre Mfg. Co.; and A. W. Hine, Phelps & Adams, San Francisco.

Traveling men who "made" Indianapolis, Ind., last week were: J. M. Morrow, American Watch Case Co.; Wade Williams, Arnold & Steere; Wm. W. Middlebrook, B. A. Ballou & Co.; H. E. Vincent, Simpson, Hall, Miller & Co.; Gus. Rodenberg, S. & B. Lederer Co.; B. Brady, B. B. Brady & Co.; Mr. Crandall, J. L. Crandall & Co.

Among the salesmen who visited the Philadelphia, Pa., trade last week were: Leveritt S. Lewis, Morris Prager & Co.; Charles F. Duffy, Enos

Richardson & Co.; H. H. Hamilton, Wm. B. Durgin Co.; Herman Friese, Fred. W. Lewis & Co.; F. M. Woodland, Jones & Woodland; George Osborne, William Smith & Co., and John D. Batten.

Among the traveling salesmen who called on Cleveland, O., houses recently were: C. E. Dorr, Gorham Mfg. Co.; J. R. Goodwin, Carter, Hastings & Howe; S. E. Vansant, Simons, Bro. & Co.; Mr. Beardsley, Geo. W. Shiebler & Co.; H. R. Mount, for A. Wittnauer; Jno. A. Abel, David Kaiser & Co.; Mr. Tinker, The W. B. Durgin Co.; J. I. Metcalf, R. Blackinton & Co.; Mr. Howard, Dominick & Haff; Frank Schoureck, Deutsch Bros.; Mr. Williams, Gorham Mfg. Co.; Mr. Reed, Reed & Barton; C. P. Young, W. B. Kerr & Co., and others.

Travelers in St. Louis, Mo., last week were: M. Lampert, Henry Zimmern & Co.; H. A. Bliss, Krementz & Co.; H. C. Barker, Mandeville, Carrow & Crane; F. R. Horton, Carter, Hastings & Howe; Henry H. Jacobson, Jacobson Bros.; R. Guntzburger; Wm. Matschke, A. Joralemon & Co.; Thos. E. Rogers, Riker Bros.; F. M. Van Houten, Van Houten Bros. Jewelry Co.; H. W. Van Houten, for C. Sydney Smith; Ernest A. Rose, Allsopp Bros.; C. W. Cary, J. B. & S. M. Knowles Co.; DeWitt A. Davidson, Wallach & Schiele; Rudolph Noel, Albert Lorsch & Co.

Mr. Pettee, the successor to Mr. McCormish, of the Waterbury Clock Co., visited Omaha last week. Mr. McCormish traveled through the west for 20 years and was probably known to every jewelry man west of the Mississippi river. S. W. Abbey, who has represented E. Ira Richards & Co. for 15 years, was in that city last week and reported orders large all over the west. Other travelers in Omaha were: Hugh King, Knickerbocker Silver Co., Port Jervis, N. Y.; A. J. Stover, Suplee-Reeve-Whiting Co., Philadelphia, Pa.; Mr. Smith, Wilcox Silver Plate Co., New York; C. F. Warren, Florence Mfg. Co., Florence, Mass.; H. G. Nye, C. Rogers & Bros., Chicago, Ill.

Calling on Syracuse, N. Y., jewelers the past week were: F. D. Smith, N. E. Whiteside & Co.; Emil Pick, Hammel, Riglander & Co.; V. L. Burgess, Krementz & Co.; J. E. Simonson, A. J. Hedges & Co.; C. D. Hintze, Enos Richardson & Co.; Mr. Kent, Geo. O. Street & Sons and Wm. H. Ball & Co.; C. S. Fake, Whiting Mfg. Co.;

## A CARD.

Having severed my connection with George W. Dover, whose line I have carried for the past three years, I wish to notify my many friends in the trade that I am now with Thomas W. Lind, the well-known manufacturer of findings at 67 Friendship Street, Providence, R. I. I shall call upon the trade in a few days, with a complete line of findings, settings, galleries, and other trimmings, also for millinery, leather goods manufacturers, etc.

FRITZ L. KRAUS.

# Of Greatest Importance

to the live manufacturing Jeweler is a careful consideration of our lines of Jewelers' Findings.

NEW ASSORTMENTS OF

## Buckles, Galleries, Brooches, Settings, Pins, Etc.

# THOS. W. LIND,

MANUFACTURER OF JEWELERS' FINDINGS,

67 FRIENDSHIP STREET,

PROVIDENCE, R. I.



**HOW ABOUT DIAMOND AND PEARL PENDANTS?**

*Our stock of these meets every requirement—patterns and prices of the prosperity-producing kind. Try some of these stock-brighteners on your next order.*

**HENRY FREUND & BRO.,**  
DIAMONDS, WATCHES and JEWELRY,  
9, 11 & 13 Maiden Lane, NEW YORK.  
ELK GOODS A SPECIALTY.

S. Cohn, Oppenheimer Bros. & Veith; W. R. Cattle, Henry E. Oppenheimer & Co.; Fred. T. Long, Allsopp Bros.; Mr. Roth, Watson & Newell Co.; Mr. Wagner, Wagner Mfg. Co.; H. W. Sherrill, Sinnock & Sherrill; E. C. Holbrook.

Traveling men visiting the Hub the past week included: Jerome C. Adler; Charles S. Yasbel, Louis Strasburger's Son & Co.; Henry E. Ide, H. C. Hardy & Co.; Mr. Williams, for G. Armeny; H. B. Beach, International Silver Co.; W. G. Clark; Harry Barrows; John Tweedy, Cheever, Tweedy & Co.; Mr. Lederer, S. & B. Lederer Co.; E. E. Richardson, R. F. Simmons & Co.; C. E. Mott, J. B. Bowden & Co.; Ed. Horton, Mandeville, Carrow & Crane; Harold Sweet, R. F. Simmons & Co.; Louis Jones, C. A. Marsh & Co.; E. W. Martin; Arthur Rutherford, H. A. Kirby Co.; Chris. Morgan, Rogers & Bro.; Mr. French, Riley, French & Heffron; Arthur Grimshaw, B. A. Ballou & Co.; Frank Lawton, Lawton, Sherman Co.; J. B. Ellis, Parks Bros. & Rogers; W. S. Ripley, Watson, Newell Co.; A. J. Lambert, Aikin, Lambert & Co.

**Americans at Kimberley.**

THE great diamond industry of Kimberley, combined by Cecil Rhodes into one vast consolidated company representing a market value of \$90,000,000, is managed by an American. He is Gardner Williams, and his assistant, Louis I. Seymour, is also an American. The selection of Mr. Williams was made by Mr. Rhodes.

The way Williams got to South Africa is an interesting tale. It was when the great Transvaal gold find of Witwatersrand was first attracting English attention. There were many doubts in the beginning among London capitalists of the real value of the ore. The London house of Rothschild determined to investigate and directed its American correspondent to engage an American gold mining authority to visit the African workings. Mr. Williams, a famous expert of the western American gold fields, was engaged for the purpose. He went to the Transvaal, traversed the beautiful grazing lands so different from the gold country of America, entered a few shafts in the "reefs" of that marvelous deposit, unlike any other on earth, examined the black, powdery, alluvial soil that the burghers said was ore—and was disgusted.

Never in the experience of man had gold been found under such conditions, and Mr. Williams was unbelieving. He even doubted the pannings. He regarded the alleged results as fraud and eventually reported that the whole business was not worth getting off one's horse to look at.

That same black alluvial plain a few years later was turning out \$40,000,000 worth of gold per annum. But, losing this great chance, Mr. Williams nevertheless made a hit at Kimberley, and is now the manager of the greatest diamond field on earth.

**CHATELAIN BAGS. PATENT FRAME.**

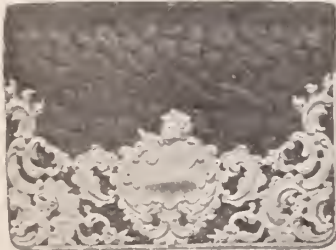

STERLING MOUNTED POCKET-BOOKS, CARD CASES, Etc.

**All Fashionable Leathers**

SPECIAL HOLIDAY LINES.



**C. F. RUMPP & SONS,**

FINE LEATHER GOODS,

Fifth and Cherry Streets, - Philadelphia.  
New York Salesroom: 621 Broadway.

**TO BLOW EFFECTIVELY IS AN ART**

which we never practice personally; but we have invented a machine which does it for us, called the

**"Reichhelm Pressure Blower."**

This, with Gas Furnaces and Jewelers' Tools generally, is the stock in trade of

**E. P. REICHHELM & CO.,**  
23 JOHN STREET, NEW YORK CITY.

WOOD CUTS.

**TIP & BEATE**  
JEWELERS' ELECTROTYPE  
New York, N.Y.

89 FULTON STREET.  
TELEPHONE 645-JOHN.

ESTABLISHED 1840  
TRADE MARK

**SIMONS BROS. & CO.**

SILVERSMITHS, JEWELERS.  
PHILA. NEW YORK CHICAGO  
MAKERS OF GOLD AND SILVER THIMBLES.

**ANY BOOK** pertaining to the Jewelry, Horological, Optical or Kindred Trades can be obtained through The Jewelers' Circular Publishing Co., 11 John St., New York. Send for catalogue. It is free.

WATCHES OF PRECISION.

**MATHEY BROS., MATHEZ & CO.,**

WATCHES DEMAGNETIZED.

MANUFACTURERS AND IMPORTERS OF

Superior Plain and Complicated

**WATCHES AND MOVEMENTS.**

Small Lever Watches a Specialty.



10 SIZE MOVEMENTS. BRASSUS, SWITZERLAND.

21 & 23 MAIDEN LANE, N. Y.

10 SIZE SPLITS.

### Philadelphia.

James D. Hughes, wholesale jeweler, has returned from a trip through the State.

Walter Parker, formerly of Bailey, Banks & Biddle Co., has accepted a position with H. Muhr's Sons.

The Bailey, Banks & Biddle Co. have placed on sale a rare collection of old Sèvres made during the period of the First Empire.

J. Albert Caldwell, of J. E. Caldwell & Co., has been nominated for re-election to the Board of Governors of the Union League.

John F. Simons, of Simons, Bro. & Co., has been appointed a member of the Publication and Library Committees of the Manufacturers' Club.

F. Ruchteshell, of Hamilton & Son, silversmiths, 13th and Sansom Sts., has been proposed for membership in the Philadelphia Jewelers' Club.

Notices have been sent out by the Horological Society of Philadelphia of a social gathering to be held at Columbia Hall, Thursday, Nov. 23.

Jacob Muhr and John F. Simons took a prominent part in the musical smoker given last week to the delegates to the International Commercial Congress.

The jewelry store of A. H. Clement, Haddonfield, N. J., was robbed last week by thieves who were supposed to have hidden in the store during business hours.

Herman Muller, a well known miniature painter, who has done the bulk of the work for H. Muhr's Sons and other leading jewelry stores, has opened a studio at 1704 Chestnut St.

A valuable collection of diamonds, jewelry and old family plate, formerly the property of William C. Murphy, deceased, was sold at auction last week. The major portion of the goods was purchased by retail jewelers.

The Philadelphia Jewelers' Club were to hold an important meeting at their headquarters, 1225 Chestnut St., Tuesday, Nov. 14, to discuss and act upon the proposition to hold open house on Thanksgiving Day. It was proposed also to give a turkey dinner at the club house on that day.

Harry Baldwin, who was arrested for the larceny of a diamond stud from the jewelry store of his employer, J. C. Dotter, 1837 Columbia Ave., has been released from prison at the instance of Mr. Dotter, who generously withdrew the charge when he learned that the diamond had been stolen to enable his salesman to reach his father's death bed.

A true bill of indictment has been returned against Alice, Irene and Ambrosine Mordecai, charged with the larceny of jewelry from Wanamaker's and other Chestnut St. stores. It will be recalled that when these women were arrested unusual attention was attracted to the case by the action of the Mayor in discharging them and denouncing the arrest as an outrage. Mayor Ashbridge went bail for the women, but, in face of strong public disapproval, subsequently withdrew as bondsman.

The receivers of the Akron Silver Plate Co., Akron, O., have paid the creditors a final dividend of 11.7 per cent.

### Trade Gossip.

J. B. & S. M. Knowles Co.'s line of silver ware is to be seen in New York this week at the Hotel Bartholdi, 23d St. and Broadway, where the exhibit is in charge of their representative, A. Eastwick Wood. Mr. Wood will stay at this hotel until Nov. 18.

C. Rogers & Bros., Meriden, Conn., have just issued a handsome catalogue of silver plated hollow ware of 92 pages, each page illustrated with handsome half tones. This is a comparatively new departure for this house, as the name of C. Rogers & Bros. has only been used heretofore on flat ware, and has become identified with that branch of the industry.

One of the prominent window displays in the New York jewelry district, last week, was that of Cross & Beguelin, 17 Maiden Lane. The feature of this display was the large and beautiful collection of fine mounted diamond jewelry which it embraced and which attracted the attention of the passers-by. Among the goods were diamond and diamond and pearl brooches of various shapes, and a large number of diamond and sapphire, diamond and ruby, and diamond and emerald rings.

To complete their lines of Christmas and holiday specialties jewelers will find no better assortment of desirable and seasonable goods than that offered by Le Boutilier & Co., 18 E. 17th St., New York. Here he may obtain absolutely new productions in such cut glass pieces as whisky and other liquor bottles, decanters, etc., with or without silver mounts, not to mention the art pottery and fancy goods lines carried by this firm, the character of which is so well known as to make specific mention superfluous.

### Birmingham, Ala.

William Rosenstihl, Jr., is at Union Springs with his brother for a few days.

John B. Rosenstihl, formerly member of the jewelry firm of Rosenstihl Bros., this city, has gone with E. Gluck, for a time at least.

At the State Fair H. C. Abbott, of H. C. Abbott & Bro., jewelers, has offered a prize of considerable value for the prettiest 2 year old baby.

J. H. South, general merchant at Montevallo, has assigned. Mr. South was formerly a member of the C. N. Maxwell Jewelry Co., Tuskaloosa, but sold out to enter business for himself. He carried a large jewelry stock at Montevallo.

On the occasion of Admiral Schley's visit to Birmingham the train stopped for a short time at Anniston, where M. F. Doering, jeweler, that city, presented to the Admiral a beautiful silver spoon engraved "Anniston, Ala., Nov. 6, 1899." The present was received with grateful appreciation by the old sea fighter.

Miss Josie Gluck, the sister of Emil Gluck, jeweler, who was so badly burned by an accident at the store of her brother on the night of Oct. 28, died from her wounds Nov. 6. She was in the diamond department and was to her brother a valuable assistant. The remains were interred at the old family plot in Cleveland, O.

## "THE AMERICAN BEAUTY"



IN

## Sterling and Essex

UNEQUALED.

## Hayden Mfg. Co.,

21-23 MAIDEN LANE,

NEW YORK.

THE EMPIRE WESTWARD TAKES ITS WAY

# WESTERN SUPPLEMENT

## THE JEWELERS' CIRCULAR

VOL. XXXIX.

NEW YORK, WEDNESDAY, NOVEMBER 15, 1899.

No. 16.

### Chicago Notes.

All communications in reference to the Chicago department of *The Jewelers' Circular*, addressed to Stephen Parlin, 1522 Lill Ave. (Telephone, Lake View 397), Chicago, will receive prompt attention.

Col. Leavenworth, treasurer of R. Wallace & Sons Mfg. Co., has been paying a visit to the Chicago office.

A. L. Sercomb left Saturday for a 10 days' business visit at New York and the Meriden Britannia Co.'s factory, Meriden.

M. N. Burchard spent a couple of days last week in St. Louis, Mo., on business for factory L. of the International Silver Co.

T. Y. Midlen, of the Gorham Mfg. Co.'s New York house, spent the past week here with Manager Ghislin, of the Chicago office, returning to New York Saturday.

Superior Plating Co., Chicago, have incorporated for manufacturing and metal plating. Capital, \$2,500. Incorporators: C. J. Barry, H. Shuler, E. G. Henkel, all of Chicago.

J. J. Vanderburg, Duluth, Minn., who has been in a hospital here for six weeks under surgical treatment, has passed the operations successfully and returned to his home. He is still somewhat weak, but is confident now of his ultimate recovery.

The referee in the affairs of Geo. Rohrer, Hancock, Mich., has directed that a 15 per cent dividend be declared Nov. 17. It was thought that the property of Mr. Rohrer, who had been a long time in business, would yield more to the creditors.

David Willems, employed as a shipping clerk for Sears, Roebuck & Co., Fulton and Desplaines Sts., is under arrest, charged with larceny. He confessed to Lieut. O'Connor that he had systematically robbed the firm during the past three months. Willems says he frequently carried away articles of jewelry, which he disposed of to second-hand dealers.

Irving H. Chase and George M. Van-Deventer, the former the secretary and the latter the New York manager for the Waterbury Clock Co., have been making their annual visit to the Chicago offices of the company. In consultations with Manager Dodgshun, they are looking ahead to the coming year's business and devising ways and means for supplying the trade.

In response to an invitation to meet Congressman Foss, of the Seventh Illinois District, at the home of M. N. Burchard,

on Warwick Road, Kenilworth, a large number of the residents of the village have signified their intention to be present on Saturday evening, the 18th inst. It is expected the Congressman will relate some of his interesting experiences abroad, probably touching upon his visit with Emperor William aboard the latter's yacht.

Fire recently damaged the West Side factory of the Sercomb & Sperry Co., 43 W. Washington St., to the extent of \$2,000. The blaze started at 2 o'clock A. M. on the upper floors, and the damage to the Sercomb & Sperry Co.'s works was caused by water only. This factory is used for silver plating large articles only, and amalgamating plates for mining purposes. The fire in no way disturbed their other plating business, and the damage to the West Side factory has already been repaired and the place put in running order.

A committee of the Chicago Jewelers' Association, consisting of Lem W. Fler-shem, chairman; A. L. Sercomb, W. H. Vogell, M. A. Mead and James A. Todd, have been appointed to take charge of all matters relating to the forthcoming banquet and perform all duties except those of reception committee. The banquet will probably be held on Thursday in the third week of January, but this will depend somewhat on the convenience of the speakers and arrangements for a suitable banquet hall. The time selected is a good one, not too soon after the holidays, and yet early enough so that those who leave the city after the year's business is closed up will be able to attend. With such banquet managers as those named in the above committee a royal time is assured.

Buyers were not quite so numerous last week, but it is the opinion of dealers that seasonable weather would add largely to the number. Among those from a distance were: George H. Thoma, Three Rivers, Mich.; W. H. Clawson, Minocqua, Wis.; S. Nordlinger, Los Angeles, Cal.; C. E. Searles, Merrill, Wis.; L. A. Fonder-smith, Hoopetown, Ill.; D. S. Whittaker, Lebanon, Ind.; J. F. Cook, Dowagiac, Mich.; J. M. Bostwick, Fort Washington, Wis.; M. F. Tinsley, Harlan, Ia.; L. D. Dana, Antigo, Wis.; S. E. Dickinson, Hartford, Wis.; N. A. Osgood, Louisville, Ky.; Charles S. Sands, Kirksville, Mo.; Mr. Gansl, of Gansl Jewelry Co., Grand Forks, S. D.; C. I. Daniels, Athens, Mich.; Mr. Eyrich, Jackson, Miss. Besides those from a distance there were a number of near-by jewelers in, among

them both Mr. Lundgren and Mr. Wilson, of Lundgren & Wilson, St. Charles, Ill.; L. H. Bauer, A. M. Smythe and Emil Fink, Elgin, Ill.; L. M. Bird and William Egermann, Aurora, Ill.; Howes Bros., La-porte, Ind.; W. P. Yeoman, Waukegan, Ill.; W. H. Drechsler, Oak Park, Ill.; Lyon & Son, Evanston, Ill.; Axel Kling, Hegewisch, Ill.

### Omaha.

A. W. Tabor, Tabor, Ia., was a purchaser of jewelry in Omaha last week.

L. A. Griffith, of Griffith & Hall, jobbers, has been in the city for a few days, and reports business throughout Iowa as very good.

M. L. Kile, an experienced watchmaker, who has just completed a course in engraving and optics in the Omaha Horological School, will open a new jewelry store in Creighton, Neb., about the middle of this month.

H. Eisele, engraver to the trade, who has also taken up assaying during the last two years, is now in the Black Hills conducting an excursion from this city to inspect a mine in which he and other Omaha men are interested.

Albert Edholm recently secured eight large pearls from a lady who had just returned from Manila. Her husband was in the commissary department. The pearls are very handsome, and were pawned by a wealthy family in Manila at the beginning of the war. They were a product of the islands.

A returned volunteer of the Iowa 51st Regt. told an Omaha jeweler that a silver joint snake ring he had purchased from him for \$2 a year ago was deemed such a curiosity in the Philippines that he traded it to a Spaniard for a rich uniform of an officer high in rank and worth probably over \$100.

S. N. Kempton, who has been attending the Omaha Horological School, has started in business for himself in North Platte, Neb. Ernest Moore, a graduate of the school, has taken charge of his father's business in Harvard, Neb. D. E. Fair, a graduate of the school, has returned to his home in Blue Ridge, Mo., and is looking for a location where he can buy out a stock or put in a new one. Fred Harris, Winterset, Ia.; W. F. Hansen, Jamestown, Kan.; George Goe, Clearfield, Ia., and M. M. Hoyal, Bois d'Arc, Mo., have entered the Omaha Horological School.



**Kansas City.**

J. S. Lang has opened a new jewelry store at Coffeyville, Kan.

Thieves entered the store of J. M. Marks, on Grand Ave., last week and secured about 10 watches and a small quantity of plated ware.

A fire which started in the Jones Dry Goods Co., Nov. 3, spread to other business houses, and among the losers was M. Rotenberg, jeweler, 602 Main St.; loss \$125.

Daniel A. Dabney and Chas. T. Wheeler, of Troy, Kan., have been arrested and charged with arson. Last May their store burned down. The insurance was paid at the time, but lately investigations have developed clues which led to their arrest.

The entire State of Kansas celebrated last week, the occasion being the return home of the 20th Kansas U. S. V. from their service in the Philippines. Every town in the State that had returning soldiers presented medals to them, and those towns that had no soldiers had medals made, took them to some other place and presented them to some company. During the grand celebration in Topeka, Kan., the stores were most beautifully decorated, all of the local jewelers doing their part. Some of the manufacturers in Kansas City worked day and night to finish the medals in time, Fred Chamberlin furnishing all of the medals for Co. B, of Kansas City, Kan.

**Indianapolis.**

Ely Millard has opened a new jewelry store in Michigan, Ind.

Letters from E. C. Miller tell of his greatly improved health since reaching Mexico.

Charles Conner, with John Wimmer, optician, is secretary of the Indiana Optical Society.

On Nov. 1 Miss Frieda Walk, the second daughter of Mr. and Mrs. Julius C. Walk, was married to Dr. Reginald W. Garstang.

Chris Bernloehr has removed to larger and more convenient quarters. He is now located at the Washington St. entrance to the Pembroke Arcade.

Buyers in town last week included: O. L. Means, New London, Ind.; J. W. Hudson, Fortville, Ind.; Ike Booth, Tip-ton, Ind.; Shelburne Bros., Zionsville, Ind.; A. A. Garner, Lebanon, Ind., and L. C. Phillips, Carbon, Ind.

**Columbus, O.**

**BUSINESS OUTLOOK.**

The outlook for a good holiday business here was never better than right now, and the jewelers' windows begin to show that they fully realize the conditions which prevail. All are preparing for the season with unusual care, and are putting in a stock of goods that would have appalled the average jeweler a year or so ago. Inquiries show that the demand for articles in solid metals is now unusually good and high grade novelties also sell well. One prominent jeweler said to THE CIRCULAR representative the other day that dealers in his line of goods count on the holiday trade as half the year's business in Columbus, and for that reason they were looking forward to the time this year with rather unusual anticipation.

J. A. Schofield has opened a store in the Scott block, Plain City, which he occu-

piated when he was in business at that place once before.

Harry P. Wilson, who had been with P. C. Krouse & Co. for more than 11 years, has opened a new store at 362 N. High St., and has put in a nice stock of jewelry, silver ware, watches, diamonds and other goods.

In a big fire at Massillon a few days ago the jewelry store of C. J. Duncan was damaged to the amount of \$8,000. He had insurance of \$5,000. The fire originated in the department store of Allman & Wetter, and destroyed about 12 stores, causing a damage of fully \$250,000 in all.

A large number of eastern engravers have recently been employed by the Duerber Watch Case Works, Canton. Most of them went to work last week. The Duerber-Hampden works have been running four nights per week for some time, and the outlook for next year is very encouraging.

**ABSOLUTELY THE BEST.**



1 DWT.  
EASY-FLOWING  
GOLD  
SOLDER  
Best on Earth

Manufactured by F. H. NOBLE & CO.,

103 State St., Chicago.

Sold by all Jobbers.

**Georgian STERLING SILVER.**

In Complete Table Service—

French Gray Finish.



COFFEE SPOON.

**TOWLE MANUFACTURING CO.,**  
CHICAGO. NEWBURYPORT, MASS.



**LINKS.**

Just a Word Regarding Our

**Anniversary Line of 10K. Link Buttons.**

Every Die New this Season, and Every Pattern a Work of Art.

We guarantee them not to break and will give a new pair in exchange for any pair that does not give satisfaction.

**JOHN T. MAURAN MFG. CO.**

NEW YORK OFFICE,  
3 MAIDEN LANE.

FACTORY,  
PROVIDENCE, R. I.

## Cincinnati.

### BUSINESS CONDITIONS.

Business is very brisk among all the jobbing trade, and some of the retail men are giving encouraging reports of increasing trade. The jobbers still complain about the scarcity of movements. One said last week he could have sold a lot of gold cases if he could have furnished the movements for the same. Many of the jobbers who make personal trips are home for new stock and say they never had such sales in so short a period.

Mr. Galbreath, of Duhme Bros. & Co., goes east this week to make holiday selections.

B. S. Newman, of Frohman & Co., is back from a trip, and will go south this week for a long trip up to Christmas.

W. V. Foster, Tipton, Ind., was last week in Cincinnati, buying goods and new fixtures for his store. He intends to have a beautiful store for the holidays.

A. G. Schwab & Bro. are making new arrangements in their store. They will have new cases for jewelry, and their counting room will be enlarged.

Mr. Shambaugh, who was reported seriously ill at Detroit last week, is improving, the crisis being passed, but he will not be able to travel any more this year.

A. E. Axman and wife, Franklin, O.; Harms & Allen, Napoleon, O.; Nicholas Sanney, Walton, Ky.; A. R. Grove, Bluffton, Ind.; J. S. Throp and wife, Greensburg, Ind.; H. P. Wilson, Columbus, O., bought goods in Cincinnati the past week.

## St. Louis.

Among out-of-town jewelers here last week: R. C. Hailey, Jonesboro, Ark.; Fred Simon, Collinsville, Ill.; Chas. Norman, Alton, Ill.

Charles Williams, who assaulted Henry Hirschberg and attempted to rob the latter's store some months since, has been sent to the penitentiary for two years.

W. F. Kemper has been elected president of the Franklin Avenue Merchants' Association, and managed the recent entertainment given by that organization.

At the recent Horse Show the delivery wagon of the E. Jaccard Jewelry Co. was awarded second prize. The reason for it not obtaining first prize was that the turnout was too fine.

## Cleveland.

### BUSINESS OUTLOOK.

Cleveland jewelers are preparing for a very busy Christmas season, and one can see clerks at work in many of the stores several evenings a week displaying of new stock and rearranging the old.

Phil Cohen has opened a jewelry store, corner of Ontario and High Sts., in the down-town district.

Miss Rose Blumkin, of this city, is in the Klondike with a stock of jewelry and millinery, and it is said she is doing well there.

A petition in bankruptcy was filed in the United States Court here by John T. Roberts, retail jeweler, East Liverpool, O. His liabilities are \$4,304.85, and assets \$271.50.

Frank H. Kramer has added to his business in the Y. M. C. A. building, by purchasing the stock and good-will of Rudolph Winzenried, corner of Ontario and Prospect Sts. He will run both stores in future.

J. H. Danforth, secretary and treasurer of the Cowell & Hubbard Co., was taken severely ill on his way to the store Saturday morning. After a few hours he was able to take a carriage and go to his home, where he will have to remain for a few days at least.

The Sigler Bros. Co. have been systematically robbed by a trusted employe. Joseph Cerney, who has been in their employ for about seven years, was last week detected and arrested under the charge of embezzlement. The amount which he is specifically charged with embezzling is \$2,000. For some time he has been under suspicion, but detection was only effected last week. Cerney is 22 years of age.

## Pacific Northwest.

N. L. Taylor, Idaho Falls, Idaho, has gone out of business.

Sumpter, Ore., has a new jewelry store. A. H. Harris is the proprietor.

Albert Barnes is moving his jewelry stock from Jacksonville, Ore., to Ashland, Ore.

Johnson, jeweler, Sheridan, Mon., has moved to new and more commodious quarters.

H. B. Meyers is visiting Medford, Ore., and is thinking of engaging in the jewelry business there.

Potter Bros. are erecting a small temporary building on their recently purchased lot at Chinook, Mon., and will move in their jewelry stock soon.

Sig. Lipman, Lewiston, Idaho, has sold his interest in the Lewiston Loan Office to his partner, Julius Wolter, who will in future confine his business to jewelry, watchmaking and repairing.

## Pacific Coast Notes.

R. A. Bay, Madera, Cal., has sold out to L. H. Service.

F. A. Ward has opened a jewelry store on 5th St., Oxnard, Cal.

J. A. Janowski, jeweler and optician, has opened a repair shop on B St., Biggs, Cal.

S. Conradi, Los Angeles, Cal., has left for the east to obtain the 33d degree of Masonry.

L. Feibush, jeweler, Stent, Cal., is seeking a new location in Groveland or Big Oak Flat, Cal.

E. B. Bullock, of Wm. H. Wilmarth Co., Attleboro, Mass., has been in Pleasanton, Cal., recently.

R. Reid, Haywards, Cal., has perfected arrangements whereby he will keep a first class optical department.

Boyd & Stahl, San Diego, Cal., have dissolved partnership. Mr. Boyd has opened a new store in the same city.

John S. Jarnigan, a watchmaker and jeweler of Knoxville, Tenn., has accepted a position with R. E. Baughman, Roswell, N. M.

M. Goldberg will shortly erect a building on the corner of Main and Line Sts., Bishop, Cal., for use as a jewelry store and repairing establishment.

Painters have been at work putting Keshishyan & Giant's store, Vallejo, Cal., in good order. The recent fire necessitated a renewal of the interior and exterior.

The establishment to be occupied by Annin & Hall, a new firm of jewelers, opticians and watchmakers of Pasadena, Cal.,

is being fitted up. A modern plate glass front will be put in and the place will be ready for occupancy next month.

Charles Harris, a well known jeweler of Wheatland, Cal., died a few days ago in that city from paralysis. The deceased was a native of Cornwall, England, and about 56 years of age. He was naturalized in August, 1879, in Storey county, Nevada. He leaves a widow, two daughters and five sons.

## San Francisco.

### TRADE CONDITIONS.

There seems to be no relaxation in the rising tide of the jewelry trade. Orders are coming in faster and faster as the season progresses. Travelers report an improvement of the country retail business in all sections. Advertisements of "jewelers wanted" are appearing in the San Francisco papers from jewelry firms in Seattle and Los Angeles.

E. Haas, Haywards, Cal., was last week in town buying stock.

Mr. Perkins, of J. D. Perkins & Son, Ione, Cal., is in San Francisco this week.

Fred Roth, representing L. & M. Kahn & Co., New York, was in town last week.

Mr. Giant, of Keshishyan & Giant, and H. G. Frey, two jewelers of Vallejo, Cal., were in town buying stock last week.

J. B. Whitney has returned from his southern trip. He reports that trade in Los Angeles and southern California is much improved by the recent rains.

A new retail store has been opened at 2005 Mission St. The proprietors are Landa & Goodenough, and the store is to be known as The Mission Jewelry Store.

Allan Marshall has closed out his business in the Thurlow block, and will take charge of the watchmaking department of the new firm of Lundberg & Lee, 232 Post St.

One of the features of the season is an unusual demand for silver ware. The present demand for large pieces of silver is greater in proportion to past demand than almost any other line.

J. H. Langhorst, Jackson, Cal., was in San Francisco a few days ago on business. Among other visiting members of the trade were Charles Niner, Santa Maria, Cal., and A. O. Solberg, Everett, Wash.

A. Kaiser, Stockton, Cal., was in San Francisco a few days ago on business. He reports the prospect for business in Stockton this Winter to be better than any previous year of its history. The grain crops were heavy, and there is now plenty of money in circulation.

Arthur F. Lundberg and Albert E. Lee, both of whom were for many years with Shreve & Co., on Nov. 11 opened a retail establishment at 232 Post St. They will deal in jewelry, silver ware, cut glass, watches, clocks, etc. They have employed Allan Marshall, formerly of the Thurlow block, to take charge of the watch repairing. They have also secured the services of a well known jewelry expert. The store has been finely fitted up. Their factory and repair shop has been located in the rear of their retail establishment. They have a good situation on one of the best business blocks on Post St., where some of the best trade of the city is to be secured.

**Queries by Circular Readers.**

**Note.**—Questions under this department will be answered as promptly as possible. Some queries require careful investigation before a satisfactory answer can be given; hence such answers are often seemingly delayed. THE CIRCULAR desires every jeweler to take advantage of this department.

MT. PULASKI, Ill., Oct. 27, 1899.

Editor of THE JEWELERS' CIRCULAR:

Can you tell me of any satisfactory way of cleaning large pieces of silver, such as salvers, etc., besides the cyanide process?

Yours truly, W. W. MAYER.

**ANSWER:**—There are a number of compounds and solutions for cleaning silver, most of which have cyanide of potassium as their basis. But the following, which we recommend, is effective and simple in its preparation. It is made by dissolving an ounce of nitrate of silver in a quart of pure, distilled water, or if this is not obtainable, then in a like quantity of boiled water. After the nitrate of silver is thoroughly dissolved, add a small quantity of powdered hyposulphite of soda—which in itself is a very good cleansing agent for silver ware—which will precipitate the silver. When this has taken place, a further addition of hyposulphite of soda should be made, which will eventually redissolve the precipitate, and the cleanser is ready for use. In order to make a good, strong solution, the hyposulphite of soda should be added slightly in excess. Shake the solution well and apply, after which the article should be rubbed with a chamois skin or a cotton flannel cloth. If the article is satin-finished, no further treatment is necessary, but if it is polished, the polish is restored by rubbing the article with the palm of the hand, or with a chamois skin which has been dipped into a mixture of the finest soft rouge and alcohol, to which a small quantity of water has been added.

**Thirty-three Years at the Same Bench.**

**T**HERE is probably no other man in the city who has watched its growth from one outlook so long as C. W. Hinman, watch repairer in L. M. Barnes's jewelry store in the Wilson block on Main St. Mr. Hinman went to North Adams 33 years ago last month from Newark, N. Y., his native town, and entered the employment of Mr. Barnes, who was one of the original tenants of the building, and who has done business in the same store ever since. The young man took his seat at a bench facing the show window, and there he has sat almost constantly during working hours for a third of a century, working as steadily as the clocks and watches that tick on the shelves and in the cases about him. His face is familiar to hundreds who have never spoken to him, and there is not a more thorough fixture in the city in animate form. The register kept in the store shows that during his term of service he has cleaned and repaired 40,000 watches at a cost of \$1 or more each. The smaller jobs are not registered, and Mr. Barnes considers it strictly within bounds to estimate that he has done work on 60,000 watches since entering his employment 33 years ago.—[North Adams, Mass., correspondent in Sunday Springfield Republican.]



**Our New....  
Jewel Case**



has been pronounced by competent judges the best in size, shape, workmanship and fitting, in the market.

**Roy Watch Case Co.,**

Makers of SOLID GOLD CASES,

21 Maiden Lane,

New York.



TRADE-MARK REGISTERED.



**"GESSOART"  
DISPLAY FIGURE.**

18 Inches High.

DECORATIONS IN APPROPRIATE COLORS.

This unique, attractive and useful article, used in the show window for special display of all manner of articles; or can be sold as a card receiver.

PRICE, BOXED, \$2.50; NET CASH WITH ORDER.

**L. W. LEVY & CO.,** Novelties and Optical Goods,

194 BROADWAY, NEW YORK.

Successors to Levy, Dreyfus & Co.



**JACOB PALMTAG,**  
Manufacturer of Watches,  
Schwenningen, (Württemberg) Germany,  
MANUFACTURES

**Watchmen's Control Watches.**

Illustrated Catalogue sent Free, post-paid.

Energetic Agents Wanted.

**JUNK-SHOP METHODS.** The time is not far distant when a jeweler will demand different methods than are now employed by some salesmen in disposing of their stock. How any jeweler with any reputation will allow an auctioneer to run in a lot of inferior goods and sell them on his reputation, using his store for a junk-shop to dispose of the auctioneer's goods, not his, is a hard problem to solve.

**E. J. GREGORY, Jewelers' Auctioneer,**  
Jewelers' Building, Boston, Mass.

HAVE YOU SEEN that pretty line of....

**REVOLVING SHAVING MIRRORS?**

Call and see them.

THE BEST SELLER OUT.

Also new ideas in TRIPLICATES.

**SELWYN IMPORTING & TRADING CO.,**

14 East 17th Street, New York.

**WATCH CASE GUARANTEES.**

**THE RETAIL JEWELERS SPEAK OUT AND GIVE THEIR IDEAS ON AN IMPORTANT MATTER BEARING UPON THEIR TRADE.**

Millions of gold filled watch cases have been sold during the past quarter century, and the vast majority have outworn and will outwear the term of guarantee that originally accompanied them, but as the months pass by the exceptional instances where the gold shell of the case has been worn through, showing the interior base metal are, taking into consideration the constantly increasing sales, bound to multiply. Until quite recently dealers have had very little trouble with the cases returned by customers, but a natural interest exists throughout the retail jewelry trade as to the cases whose long term guarantees are nearing their end. The dealer feels no anxiety about a long term filled case that has been in use only a few years, but the nearer the day of maturity the more concerned he is that the wearer of the case may discern real or imaginary defects in the case sufficient to warrant his returning it to the dealer. It was upon the request of several responsible jewelers that THE CIRCULAR entered upon the undertaking of obtaining a consensus of opinion from the retail trade, and sent to a large number of jewelers, indiscriminately, a letter of which the following is a copy:

NEW YORK, Sept. 8, 1899

WE ARE SENDING THIS LETTER TO THE RETAIL TRADE WITH THE OBJECT OF GETTING THEIR VIEWS ON AN IMPORTANT SUBJECT, NAMELY: THE GUARANTEEING OF FILLED WATCH CASES. FROM THE RESPONSES RECEIVED MAY BE EVOLVED SOME VALUABLE SUGGESTIONS.

OF THE FOLLOWING FORMS OF GUARANTEE, WHICH DO YOU CONSIDER MOST JUST, AND WHAT ARE YOUR ARGUMENTS ON THE SUBJECT?

1. SHOULD THE MANUFACTURER GIVE A NEW CASE OF THE SAME GUARANTEE IN EXCHANGE FOR THE OLD CASE THAT HAS NOT LIVED UP TO ITS GUARANTEE?

2. SHOULD THE MANUFACTURER EXCHANGE THE CASE THAT HAS NOT LIVED UP TO ITS GUARANTEE WITH ONE OF LOWER GUARANTEE? THAT IS, IF A 20-YEAR CASE HAS BECOME DEFECTIVE AT THE END OF 10 YEARS, SHOULD IT BE REPLACED WITH A 10-YEAR CASE?

3. SHOULD THE MANUFACTURER REPAIR THE CASE AND PUT IT IN CONDITION TO OUTLIVE THE UNEXPIRED TERM, IF THE CASE SHOWS THE BASE METAL BEFORE THE LIFE OF THE GUARANTEE HAS EXPIRED?

4. SHOULD HE GIVE A NEW CASE AND CHARGE FOR THE LENGTH OF TIME THE CASE THAT DID NOT LIVE UP TO ITS GUARANTEE, HAS BEEN WORN; IN OTHER WORDS, REBATE FOR THE UNEXPIRED TERM OF GUARANTEE?

YOURS VERY TRULY,

THE JEWELERS' CIRCULAR PUB. CO.

All those jewelers who did not receive this letter are cordially invited to send their views upon this subject, replying to the questions seriatim or collectively. Their replies will receive the same measure of consideration as those received direct from the letters themselves. The more views on this subject expressed by the trade at large the more convincing will be the conclusions reached.

JOLIET, Ill., Sept. 12, 1899.

Editor of THE JEWELERS' CIRCULAR:

In answer to your favor of Sept. 8, regarding filled cases, we beg to submit our opinion as follows:

1. The manufacturer cannot consistently do anything else—unless the defect be so slight that it can be satisfactorily repaired.

2. Certainly not—lower grade gold is used in 10 year cases than in 20 year, and it surely is not fair to ask a customer to accept a change of this kind.

3. This should depend on the nature of the defective part—if slight it undoubtedly can be repaired, but if general it would be difficult to successfully repair it.

4. Not if they wish to retain the good will of the customer or user, and the continued patronage of the retail jeweler.

I take it that the retail jeweler buys and sells gold filled cases in good faith—accepting the guarantee as meaning what it says and only asks that the case maker fulfill his promise.

Furthermore, if we have sold our customer a 20 year filled case that wears out in 10 years, can he expect more than 10 years' wear from another 20 year case (thus merely completing the original guarantee)? And is it fair to ask him to pay again for something he has already paid for?

I am glad THE CIRCULAR has taken up this subject, for it is a matter of much importance both to the case manufacturer and to the retail jeweler. But it is not difficult to see the end of the filled case business, if, in the first place, jewelers are asked to pay for something they do not get, viz., cases guaranteed for 20 years and only wear 10, and, in the second place, when we endeavor to make good their shortcomings to find delays, obstacles and unreasonable conditions.

Yours truly,

GEO. E. FEAGANS.

DECATUR, Ill., Sept. 12, 1899.

Editor of THE JEWELERS' CIRCULAR:

In reply to your letter of Sept. 8, in regard to manufacturers' guarantees of watch cases, we have but one view on the subject, and that is, when a filled case is guaranteed to wear for 20 years, and it fails to do so, the only way to please your customer is to give him a new case of the same quality, free of charge. There was a time, 15 or 20 years ago, when filled cases lived up to their guarantee, but of late years some factories have been putting a great many cheap filled cases on the market, and placing a guarantee on the same, knowing that the cases will not half live up to the guarantee that goes with them.

Yours respectfully,

FRANK CURTIS CO.

GALESBURG, Ill., Sept. 12, 1899.

Editor of THE JEWELERS' CIRCULAR:

Your circular letter of Sept. 8 is at hand and is a very interesting one. We think some manufacturers are to blame for all their troubles. They are to-day making cases that do not begin to equal the filled cases made 20 years ago, and in face of all that have raised the guarantee to 25 years. This was wholly uncalled for, as 20 years' wear of a filled case should satisfy any customer. We deal largely with railroad men and we think without doubt they are as hard on a watch case as any class of people who carry watches, and we venture the assertion that no engineer or fireman can carry a filled case for 20 years and not show the base metal. While on duty their hands or gloves become so oily and full of coal dust, cinders and dirt that every time they handle their watch (and it is often) it's like rubbing the case with an emery cloth. Their clothing also becomes full of dust and dirt and fairly grinds the gold off. I have carried a 20 year filled case myself for over 16 years and it looks almost new to-day, but manufacturers cannot discriminate, and as long as they warrant these cases for 20 and 25 years we say let them

take their medicine and they should replace the old with a new case equally as good as the old one was originally.

Yours very truly,

CHAPMAN & ARMSTRONG.

COSHOCTON, O., Sept. 11, 1899.

Editor of THE JEWELERS' CIRCULAR:

Replying to your circular letter of Sept. 8, beg to plant ourselves unequivocally on your first proposition, viz.: If a case is worn out within the period of guarantee that it should be replaced by a new one of the same kind and quality, otherwise your guarantee should read "to keep the purchaser in a gold colored watch for the period," etc.

Manufacturers are too prone to make extravagant representations in order to meet the false claims of some other manufacturers, when they are sure their goods will not survive the period of guarantee. If you know a thing is of sufficient merit to resist wear for 20 years, qualifying, of course, against unusual or excessive abuse, then you should be held to the strict letter of the terms of the warrant. A customer who buys a gold filled watch does it on the recommendation of the guarantee, believing that it will wear 20 years, else the maker would not give so broad guarantee. It is of no comfort to him to simply believe or know that he has a watch that will last for 20 years if it is not used, or if it is used and wears out the maker will patch it up and keep it going for the period of the guarantee.

We might say a great deal more concerning this matter in support of our opinion, but enough has been said to convey our conviction. In conclusion, let us say that we do not guarantee any filled case as long as the manufacturer does, but make a plain, frank statement of our judgment and agree to stand between manufacturer and customer as long as either or both of us are in existence. And we don't have any trouble with competition which promises everything and more than the makers. We believe watch cases should be made and stamped honestly and the guarantee for a less period than experience has shown occasional cases to wear. Then the guarantee is a stamp of quality, and the customer's pride is aroused according to the extent of his expenditure; while, on the other hand, his guarantee is a worthless recommendation which he knows is but a vehicle for shyster barter.

Make your goods honest and make the price accordingly. Very truly,

BURNS & GOSSER.

LOUDONVILLE, O., Sept. 11, 1899.

Editor of THE JEWELERS' CIRCULAR:

Your letter at hand and contents noted. In reply will say that I think the first clause would give to the public the best satisfaction, but I suppose the manufacturer would say the third. The second and fourth won't go; they would be the cause of us poor retailers getting too much abuse. But I think the thing for the manufacturer to do is to insure his cases for the term of years he knows they will wear. If the prices at present are too low to make a case that will stand the 25 years' wear, let them put out better goods and charge us accordingly. Then cut the guarantee and prices on the present output. Then I think everything will go along lovely and the jewelers will be better satisfied. Hoping the above will do you some good and be the means of telling these manufacturers where they can improve and give us more pleasure in selling filled goods,

Yours respectfully,

JAS. ROLLINS.

MADISON, Ind., Sept. 12, 1899.

Editor of THE JEWELERS' CIRCULAR:

Your letter of the 8th inst. at hand, and, in reply to your several questions asked, will state that we think a new case should be given at once, and not compel the retail merchant to wait several months for same. In our opinion the case should be exactly the same in every respect as the one of the original order.

Very respectfully, BROOKS & DOLD.

WASHINGTON C. H., O., Sept. 11, 1899.

Editor of THE JEWELERS' CIRCULAR:

Yours of the 8th at hand. In reply will say that I think the manufacturer should give a new case of same guarantee and charge same to advertising. A satisfied customer is the best ad. that he could have.

Yours truly,

C. A. GOSSARD & Co.

PARIS, Ill., Sept. 12, 1899.

Editor of THE JEWELERS' CIRCULAR:

Yours in regard to the guaranteeing of filled cases and I will say, that is a subject that I have studied, and have had over 25 years' experience with the same, and I will gladly give you my views and suggestions, in answer to your questions, viz.:

No. 1. I will say YES, emphatically; it is the only way a retail customer can be pleased; the reason why will be seen in answer to No. 2.

No. 2. Certainly not, for obvious reasons; if the 20 year case has only worn 10 years, then it is reasonable to say that the one sent to replace it will wear only the other 10 years, and generally they don't wear that long.

No. 3. Will say that it is certainly the privilege of any manufacturer to repair the same case, if he can do a workmanlike job on the case, which is not likely he can do, and if it did would cost more than a new case.

No. 4. No, if the first case did not live out its life, then the second one will not, so why should there be any charge?

Now, as to a suggestion or so, will say, the greatest trouble is with the manufacturer; he wants to put \$1 of gold in a case, and then have it wear for 20 years; it won't do it, neither will \$4 worth wear that long with the AVERAGE customer, and that is more than is in a 20 year case; however, the same case will wear with another person for more than 20 years. There is a very great difference with people who carry cases, and the conditions under which they are carried.

Cases would sell just as well, if the makers would cut their warrants in two, and then the makers and the retailer would be safe, and the people get just as much for their money; the retailer would be safe, the manufacturer safe, and the customer PLEASED. Now, why is this not the proper solution of the question? Let the maker put the same amount of gold and work in the case, and cut the life of the warrant in half. This question of filled case warrants is a serious one to the retailer who has been in the business for a long term of years, and some of the makers are getting somewhat cranky about making their warrants good. I have proof of what I say in my own experience; some make them good after a lot of quarreling, and some try to do the right thing.

Now let the makers unite and agree to warrant the 20 year case 10 years, the 25 year say 12 years, the 10 year say 3 years and the five year say one year, and then put the same amount of gold in them, and you will see all concerned happy. The customer will come back and say: "The case you sold me has worn longer than you said. I see you told me the truth and I

will buy something else." Hoping that any suggestion I have made may be of benefit to some one, I remain,

Yours truly, J. H. REED.

SPRINGFIELD, Ill., Sept. 12, 1899.

Editor of THE JEWELERS' CIRCULAR:

Your circular letter of the 8th inst. received. I believe, in guaranteeing filled watch cases, that if the case does not wear for the length of time named in the guarantee, the manufacturer should be at liberty to repair the case or give a new one which is guaranteed to wear for the length of the unexpired guarantee on the first case, and that under no circumstances would he be obliged to give a new case running the length of time of the first guarantee.

Just the same principle as an insurance policy; if you cancel the policy you pay

only for the length of time that you used the policy.

Yours truly,

GEO. W. CHATTERTON.

STREATOR, Ill., Sept. 11, 1899.

Editor of THE JEWELERS' CIRCULAR:

Yours of Sept. 8, 1899, at hand.

I think the better the guarantee the more confidence the consumer will have in gold filled cases, and the better they will sell. I think it is this guarantee (giving a new case for the old one and of the same guarantee) that has built up the gold filled watch case business. As it has been the custom in the past to give a new case for the old one, I think it would be poor policy to change.

Yours truly,

ED. REINEL.

(To be continued.)

## Another Victor.

When the crucial test comes, when quality tells, side by side with the conquerors Concord and Raleigh stands

## THE BOSTON.



O size, 3 rows of pearls, made in Montauk, 20 years' guarantee, and 14 F.K., 25 years' guarantee.

Joseph Fahys & Co.,

Established 1857.

FAHYS BUILDING,

NEW YORK.

### News Gleanings.

H. A. Skusa, Havre, Mon., is in the east buying goods.

C. C. Nufer has opened a repair shop in Huntsville, O.

A. B. Kennedy's store, Ithaca, N. Y., is being improved.

C. Goldstein, Dallas, Tex., has advertised his business for sale.

J. E. Micks & Co., Elkhart, Ind., held their opening Nov. 4.

J. E. Clemings has opened a new jewelry store in Columbia, Mo.

F. Banman, Hillsboro, Kan., has given a realty mortgage for \$600.

John Schmitz, Parsons, Kan., has given a chattel mortgage for \$800.

Samuel Goodin has opened a new stock of jewelry in Mounds, I. T.

C. A. Smith, Emmetsburg, Ia., has given a realty mortgage for \$1,900.

A suit for \$530 has been brought against Soren Jonasen, Omaha, Neb.

Edward Searles recently established a jewelry business in Richford, Vt.

J. M. Eby, Elizabethville, Pa., has added a stock of jewelry to his business.

A. Levy Tansky, Victoria, Tex., will add another story to his jewelry store.

J. A. Barth, Jr., Green Bay, Wis., is making improvements to his store.

W. R. Douglas has opened his new store in Easterbrook's block, Bristol, R. I.

A. G. Haughey, Newton, Kan., has paid off a recent chattel mortgage for \$42.

W. J. Roberts expects to return to Belt, Mon., shortly and open a jewelry store.

W. Timms, the oldest jeweler in Cleburne, Tex., will retire from the jewelry business.

C. E. Butler, Hudson, N. Y., will open a branch store in the Kane building, Chat-ham, N. Y.

T. B. Gasser, of Lowville, N. Y., will engage in the jewelry business in Carthage, N. Y.

Schofield, jeweler, has opened the store in Plain City, O., vacated by J. Manning some time ago.

The new firm of Alsted, Kasten & Co., Milwaukee, Wis., on Nov. 6 opened their store with a fine stock.

C. A. Scammon has succeeded to the entire jewelry business of the old firm of Owen & Scammon, York, Neb.

Fred A. Vogt, of Kalamazoo, Mich., has decided to locate in South Bend, Ind., and engage in the jewelry business.

Charles H. Kolter, Orange, Tex., has returned from a trip to New York and to his old home in Shrewsbury, Pa.

R. I. Bond, drug and jewelry dealer, Hartshorne, I. T., has given a chattel mortgage on his stock, etc., for \$2,000.

C. D. Strang, a former jeweler and op-

tionian, of Gorham, N. H., has secured a position with Fred L. Merrill & Co., Portland, Me.

D. Whiteside has located in Kearney, Mo., where he has opened a new jewelry store. Mr. Whiteside goes to Kearney from Liberty, Mo.

S. G. Johnson has sold out his furniture and undertaking business in Ellsworth, Ia., and will now devote his entire attention to the jewelry business.

The marriage took place Nov. 1 of W. C. Fulton, of Trask & Plain's jewelry store, Kewanee, Ill., and Miss Elizabeth McKinney, of Aledo.

W. Ellwyn White, from Minneapolis, Minn., has purchased the jewelry business of A. E. Ferguson, De Smet, S. D. Mr. White is a practical workman.

For the past few weeks a rumor has been in circulation in the Marion section of Jersey City, N. J., to the effect that the old watch factory had been sold.

Crandall & Consigny, Emmetsburg, Ia., have paid off a realty mortgage amounting to \$1,450 and given a deed on real estate for a consideration of \$1,750.

Charles H. Schaefer, for eight years watchmaker for Olin V. Neal, Parkersburg, W. Va., has engaged in business for himself at 328 Juliana St., that city.

Henry W. Vancleave, jeweler, Russellville, Ind., and Miss Eva Nichols were married at the home of the bride's parents in Russellville, a few days ago.

The jewelry business of Wetherell & Hollister, Westfield, Mass., will hereafter be conducted by Mr. Hollister, he having bought out the interest of his partner.

At Savannah, Ga., Oct. 31, Charles A. Fricker, jeweler, Americus, Ga., was united in marriage to Miss Mary C. Charlton, daughter of John D. Charlton.

Early on the morning of Nov. 8 some one broke the bulk window of jeweler E. D. Schoolfield, Millville, N. J., and seized a quantity of jewelry, making his escape.

The Bachner Time-Piece Co. have brok-en ground in Princeton, Ind., for the erection of a clock factory, and a company with \$100,000 capital stock have been formed.

Major C. B. Linn, a veteran watch-maker and jeweler of over 30 years' experience, formerly of Dallas, Tex., has opened a jewelry store at 150 Montezuma St., Prescott, Ariz.

A fire that started at 5 o'clock A. M. Nov. 3, in the jewelry store of M. B. Doty, Hawkeye, Ia., destroyed the business section of the town. Mr. Doty's loss is placed at \$3,000.

A. A. Cardwell, a jeweler of Donaldsonville, La., who stands charged with larceny, failed to appear for trial, and his bond was forfeited. The officers are anxious to find Cardwell.

At a meeting a few days ago of the Economic League of Richmond, Ind., W. E. Jenkins, jeweler, read an interesting paper on "Concentration and Specialization of Merchandising."

A. O. Marble, jeweler, who left Burlington, Vt., some weeks ago and located in Waterbury, has returned to Burlington, and will open the place he formerly occupied in the Brownell block.

On account of the death of her husband Mrs. S. Landauer, Ashland, Wis., announces that the entire stock of jewelry in her store will be closed out, as she is about to go out of business.

A. W. Bishop, Connersville, Pa., a prominent member of the local lodge of the Uniformed Rank Knights of Pythias, has received notification that he had been appointed signal officer, with the rank of captain, in the First Regiment, Uniformed Rank Knights of Pythias of Pennsylvania.

A gang of burglars is evidently infesting Hampton, Mass., as a series of petty robberies have been going on there during the past two weeks. An attempt was made to enter the jewelry store of John Gilman, but the proprietor awoke and frightened the intruders away with a shotgun.

The pearl industry along the eastern border of Iowa has been thrown into a state of excitement by the announcement that the State Board of Control was about to contract the labor of 50 convicts at Fort Madison for a term of five years at 50 cents a day to an Ognawka (Ill.) button factory.

John G. Bridgewater, jeweler, New Castle, Del., has been treated for his hearing by a Wilmington specialist. At the beginning of this treatment he was totally deaf, and his head appeared numb. Now his hearing has come back to him in a measure, and the aurist assures him that he will be very much better in a few weeks.

John Kaltenback, a jeweler, who went to Milwaukee, Wis., from Racine, Wis., was committed to the insane hospital because of a pronounced delusion that he is under a hypnotic spell, and that he has been in several trances. Kaltenback has threatened his wife, and the examining physicians report that he says the hypnotist is in league with his near friends.

William Schuster, jeweler, 507 7th St., N. W., Washington, D. C., was victimized by a well dressed negro about 5 o'clock last Monday afternoon. The fellow requested that he be given permission to pick out a ring for purchase. A pretty gold ring with two diamonds and a garnet was selected, and when the clerk turned his head the negro slipped the ring into his pocket, and in its place put a cheap ring back into the tray.

## The Mercantile National Bank

OF THE CITY OF NEW YORK,

BROADWAY AND DEY STREET,

Solicits Accounts from the Jewelry Trade.

**The Latest Patents.**

ISSUE OF NOV. 7, 1899.

- 636,246. WORKMAN'S TIME RECORDER. JOHN C. ENGLISH, New York, N. Y. Filed April 11, 1898. Serial No. 677,127. (No model.)
- 636,416. EYEGLASS HOLDER. IDELLE PHELPS, Denver, Col. Filed Jan. 31, 1899. Serial No. 703,963. (No model.)



As an improved article of manufacture, an eyeglass case or holder comprising the rear wall, the front parts separated by a central space, the narrow edge wall connecting the front and rear parts and having an opening in the top to receive the eyeglasses, and a movable lid adapted to partly close said opening, whereby the eyeglasses are locked in place.

- 636,498. GUARD OR CLIP FOR EYEGLASSES. WILLIAM I. DENGELER, New York, N. Y. Filed March 27, 1899. Serial No. 710,530. (No model.)

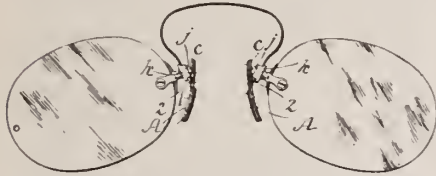

An eyeglass clip comprising two plates arranged in parallel position and having their lower ends pivoted together, one plate having a slot in its top portion and the other having an aperture in its top portion, whereby they may be conjointly and directly clamped to the post of an eyeglass by a screw passing through both said aperture and slot in such a manner as to admit of lateral bending thereof.

- 636,595. EYEGLASSES. ALBERT S. WEAVER, Boston, Mass., assignor of one-half to Camille J. Nourie, same place. Filed May 31, 1899. Serial No. 718,791. (No model.)
- The combination with an eyeglass frame, of nose-

clip supports secured thereto, nose clips each made in two parts and each part being provided with an



aperture and means passing through the aperture for securing the nose clip parts to the supports.

- 636,656. ELECTRIC TIME ALARM. GEORGE E. FRANK, Scranton, Pa., assignor of one-half to J. A. Lansing, same place. Filed Jan. 20, 1899. Serial No. 702,816. (No model.)
- 636,731. COFFEE OR TEA POT. GIDEON E. HALL, Stratford, Conn. Filed June 14, 1899. Serial No. 720,572. (No model.)



A coffee pot, consisting essentially of the body A, having a top E provided with a central opening, a collar G, located above the surrounding said opening, a support substantially at the opening to receive the ring of a coffee percolator which shall be also contiguous to the collar G, and within the same, and a removable member formed to rest upon the collar G, and comprising a cover L, a waterguard K, a funnel I joined to the guard K, at the point of support on the collar, the parts L, K and I forming a hot-air chamber, the basin M attached to said chamber, adjacent to the restricted opening of the funnel and having outlets located in a plane above the lower end of said restricted opening.

- DESIGN 31,778. BADGE. JACOB M. NABSTEDT,

**NONE BETTER.**

**THE "L" SOLDER**

Recommended by Manufacturers and Repairers.

Our Solders are not plated, but the natural color of the stock.  
Gold Solder in 1 dwt pieces. Silver Solder in 1/4-oz. sheets.  
Sold in bulk or in any thickness or width desired.  
In Low Karat—6, 8, 10, 14 and 20.

**ASK YOUR JOBBER FOR IT.**  
If he does not carry it, write us.

PRICES ON APPLICATION.

MANUFACTURED  
...BY...

**THE LEDOS MFG. CO.,**

32-34 Pearl St., Newark, N. J., U. S. A.

**Young Men, Don't Be Half Jewelers.**

What about your future? Is it as bright under your present circumstances as it would be were you equipped with the best knowledge of your profession? Why not resolve to come to us? Why not let us make a gilt-edge workman of you? Why not let us start you on the road that leads to double salary and importance?

We teach thoroughly  
**Watchmaking, Engraving,  
Jewelry Work and Optics.**

Write for our Prospectus to-day.

F. W. SCHULER, Principal,  
1215 Filbert Street, Philadelphia, Pa.

**MAINE ANNOUNCEMENT.**

**DR. KNOWLES**

will continue giving private instructions in

**Optometry**

during the month of November in Portland, Me.  
For terms and important particulars write to

**R. H. KNOWLES, M. D.,**

480 CONGRESS STREET,

ROOM 3, PORTLAND, ME.

**THE BASSETT JEWELRY CO.,**

Fine Gold-Filled Chains,  
Locketts and Gold Jewelry,

PROVIDENCE, R. I.

**H. M. RICH & CO.,**  
**Jewelry - Auctioneers,**  
**7 and 9 Franklin St.,**  
**BOSTON, MASS.**

The Superior Finish of

**CROWN 14K. FILLED**

Cases is manifest to the critical buyer.

**YOUR MONEY'S WORTH**

when insured against any possible dissatisfaction for 25 years.

**MATHEWS & PRIOR,**

DESIGNERS AND MAKERS OF

**Sterling Silverware**

TO THE LEGITIMATE

**JEWELRY TRADE ONLY,**

245-247 West 28th Street,  
New York City.



**WM. H. BALL & Co.,**

MANUFACTURING JEWELERS,

Anderson Building, 12-14-16 John St., N. Y.



**Our Specialty:**  
**Everything in**  
**Gold Bracelets.**

Curb Bracelets, Bangle Bracelets, Fancy Stone Bracelets, Baby Esther Bracelets, Bracelet Mountings.

**BUY**  
**"Simmons" CHAINS**  
**THEY SELL!**  
R.F. SIMMONS & CO.  
ATTLEBORO, MASS.  
N.Y. 9-13 MAIDEN LANE.

Davenport, Ia. Filed Oct. 2, 1899. Serial No.



DESIGN 31,779. SPOON, VICTOR BOGAERT, Lexington, Ky. Filed Sept. 23, 1899. Serial



No. 731,493. Term of patent 3 1/2 years. DESIGN 31,781. CUT-GLASS VESSEL. WILIAM HENRY GIBBS, Honesdale, Pa. Filed



Sept. 27, 1899. Serial No. 731,955. Term of patent 3 1/2 years. DESIGN 31,783. CHAFING-DISH STAND. JOHN P. STEPPE, New York, N. Y., assignor to S. Sternau & Co., same place. Filed Oct.

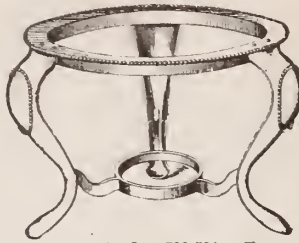

13, 1899. Serial No. 733,531. Term of patent 3 1/2 years. TRADE-MARK 33,700. FLUX FOR JEWELERS, SILVERSMITHS AND COPPER AND BRASS WORKERS. GUSTAVE GOLDSMITH, New York, N. Y. Filed Oct. 14, 1899.

**AMBERINE.**

Essential feature.—The word "Amberine." Used since Oct. 9, 1899.

**EXPIRED PATENTS.**

[Recently expired patents of interest to the jewelry trade. Reported specially for THE JEWELERS' CIRCULAR by R. W. Bishop, Patent Attorney, 723 Fifth St., N. E., Washington, D. C., who will furnish complete copies of patents at the rate of 10 cents each.]

Issued Nov. 7, 1882.

- 267,037. CATCH FOR PINS OR EARRINGS. W. C. TEMPLE, Boston, Mass.
- 267,057. WATCH KEY. ALBERT BOURGEOIS and PAUL JACKY, Bienne, Switzerland.
- 267,088. OPTOMETER. JAMES LEE, New Brighton, assignor to L. W. Levy, Edward Dreyfus and Philip Hecht, New York, N. Y.

- 267,090. FRAY FOR FINGER RINGS. BENJ. LEWKOWITZ, New York, N. Y.
- 267,092. CHIME CLOCK. JOSEPH LINDAUER, New York, N. Y., assignor to Tiffany & Co., same place.
- 267,094. TOOL FOR HOLDING FRAMES AND BACKS OF JEWELRY TOGETHER FOR BURNISHING. B. B. MANCHESTER, Providence, R. I.
- 267,104. STEM-WINDING MUSICAL WATCH. LEON FIGUET, Geneva, Switzerland.
- 267,112. SPRING RING. L. H. SANDERSON, New York, N. Y., assignor to Lysander Stillwell, Newark, N. J.
- 267,131. HOLDER FOR TABLE BELLS. J. B. BEACH, Meriden, Conn., assignor to the Meriden Britannia Company, same place.
- 267,134. LEAD OR CRAYON HOLDER. J. S. BIRCH, New York, N. Y.
- 267,161. REGULATING ATTACHMENT FOR PENDULUMS. W. D. DAVIES, Brooklyn, N. Y., assignor to himself and H. J. Davies, same place.
- 267,164. BRACELET. ANTONIO DI MARIANO, New York, N. Y.
- 267,180. FOUNTAIN PEN. JOSEPH FRIEDMANN, Seymour, Conn.
- 267,298. TIME-BALL SIGNAL. R. W. WILLSON, New Haven, Conn.
- 267,299. CLOCK FOR MAKING ELECTRIC SIGNALS. R. W. WILLSON, New Haven, Conn.
- 267,300. DEVICE FOR SYNCHRONIZING CLOCKS. R. W. WILLSON, New Haven, Conn.
- 267,309. LEAD OR CRAYON HOLDER. JOSEPH HOFFMAN, New York, N. Y., assignor to Joseph Reckendorfer, same place.

Design issued Nov. 3, 1885, for 14 years.

- 16,369. GROUP OF STATUARY. JOHN ROGERS, New Canaan, Conn.

Design issued Nov. 8, 1892, for 7 years.

- 21,974. PURSE. MAX SCHEUER, New York, N. Y.

Issued Nov. 14, 1882.

- 267,314. LEAD OR CRAYON HOLDER. LEWIS ABRAHAM, Washington, D. C.
- 267,315. BUTTON OR STUD. G. E. ADAMS, Providence, R. I.

- 267,482. MUSIC BOX. MIGUEL BOOM, Port-au-Prince, Hayti.
- 267,493. MANUFACTURE OF EYEGGLASS FRAMES. R. A. CARTER, Elizabeth, N. J., assignor to the Warwick Mfg. Co., Newark, N. J.

- 267,526. SLIDE FOR CHAIN BRACELETS AND OTHER CHAINS. JOSEPH HERZOG, New York, N. Y.

- 267,528. LEAD OR CRAYON HOLDER. JOSEPH HOFFMAN, New York, N. Y., assignor to Joseph Reckendorfer, same place.

- 267,619. ALARM CLOCK MOVEMENT. W. L. UPSON, Meriden, Conn., assignor to Bradley & Hubbard Mfg. Co., same place.

- 267,643. LEAD OR CRAYON HOLDER. C. W. BOMAN, New York, N. Y., assignor to Joseph Reckendorfer, same place.

- 267,644. SPECTACLES AND EYEGGLASSES. R. A. CARTER, Elizabeth, assignor to the Warwick Mfg. Co., Newark, N. J.

Design issued Nov. 15, 1892, for 7 years.

- 21,987. SPOON. H. M. MOSES, Richmond, Va., assignor to the H. M. Moses Company, same place.

Designs issued May 12, 1896, for 3 1-2 years.

- 25,467. BADGE. H. A. SMITH, Atlanta, Ga.
- 25,468. BUTTON. A. B. SCHOFIELD, Brooklyn, N. Y.

- 25,474. 25,475, 25,476 and 25,477. KETTLE STANDS. LOUIS WOJDKOW, Brooklyn, N. Y.

- 25,478, 25,479, 25,480 and 25,481. KETTLES. LOUIS WOJDKOW, Brooklyn, N. Y.

**SUSSFELD, LORSCH & CO.**



Ask your jobber for our lines of Optical Goods.

**Reading Glasses**

in

**Pearl and Gilt**

as well as with

**Black Handles**

AND NICKEL MOUNTED.

**Opera Glasses**

in latest styles.

37 & 39 MAIDEN LANE,  
NEW YORK.

**The Delaware Ophthalmic College**

(INCORPORATED.)

We haven't time to say very much—business is the word. Send for our catalogue and compare it with others, and you will see for yourself where the best school is in the U. S. A. to get an optical education. Two courses, attendance and correspondence.

Dr. R. S. STEPHENS, President, DOVER, DEL.



# OPTICAL DEPARTMENT.

Note.—From this week till further notice this department will be run as usual, viz.: every other week.

**Encyclopedia-Dictionary  
and  
Reference Handbook of the Ophthalmic  
Sciences.**

Copyrighted 1898, by The Jewelers' Circular Pub. Co.

By R. H. KNOWLES, M.D.

[Commenced in issue of July 6, 1898.—Continued from  
page 49, Nov. 1, 1899.]

PART XXXIX.

**Landolt, Dr.** Born at Aarau, Switzerland, in 1846; resides at present at Paris. Graduated from the University of Zurich in the class of 1869 and took a medical degree at Paris in 1875. Organized a clinic for ophthalmology at the Sabonne; in conjunction with Javal, Landolt made improvements in several instruments, as Landolt's perimeter, strabotomy forceps, ophthalmoscope, a double-bladed knife for needling operations, and an ophthalmodynamometer. Landolt's method for ascertaining an insufficiency of the internal recti muscles consists of a narrow long light. This is brought to within such a range that the two eyes cannot maintain the necessary convergence and when this fails two lights instead of one will be seen. The Landolt system takes for the unit of measure a meter and this is given the name Dioptre. This system was adopted by the ophthalmological societies at Heidelberg, in 1875. The advantage of this system over the old inch system is that by simple rules in addition and subtraction our calculations are easily determined, together with the fact that the layman cannot understand the number of the lens after the prescription is written.

LANDOLT'S SYSTEM.

Dioptres.	Focal Inches.	Value.
.12	320	314.9480
.25	160	157.4740
.50	80	78.7370
.62	60	65.6150
.75	52	52.4631
.81	48	50.4050
1.00	40	39.3685
1.12	36	35.4326
1.25	32	31.4948
1.50	26	26.2466
1.75	22	22.4963
2.00	20	19.7840
2.25	18	17.4971
2.50	16	15.7474
2.62	15	15.0280
2.75	14	14.3106
3.00	13	13.1228
3.25	12	12.1130
3.50	11	11.2481
4.00	10	9.8421
4.50	9	8.7485
5.00	8	7.8737
5.50	7	7.1579
6.00	6½	6.5614
6.50	6	6.0557
7.00	5½	5.6240
8.00	5	4.9210
8.50	4¾	4.6358

9.00	4½	4.3743
9.50	4¼	4.1400
10.00	4	3.9360
10.50	3¾	3.7493
11.00	3½	3.5789
12.00	3¼	3.2807
13.00	3	3.0285
14.00	2¾	2.8120
16.00	2½	2.4650
18.00	2¼	2.0871
20.00	2	1.9684

Dr. Landolt's writings include numerous brochures, among which are: "On the Retina," "A Manual of Ophthalmoscopy," "Examination of the Eyes," "Ophthalmic Record," "Amblyopie Hysterique," "The Anomalies of the Motor Apparatus of the Eye," "The Operation for Cataract in Our Time." His greatest work is a book entitled "A System of Diseases of the Eye," published in the United States, for students and practitioners of medicine and surgery, and which is a favorite text book in many of our medical colleges.

**Lanfranc's Collyrium** (*Lan'-francs col-lyr'-i-um*). [Proper name + Greek, *kollurion* = eye water] An eye lotion of the following formula:

℞  
 Cupri Acetatis, parts x. (10).  
 Arsenici Trisulphid, " xv. (15).  
 Pulv. Aloes.  
 " Myrrh. aa " v. (5).  
 Aquae Rosae, " cccclxxx. (380).  
 Vini Albae, " m. (1000).  
 M.  
 Sig.—Apply to phlyctenular ulcers several times daily.

**Lapis divinus** (*la'-pis di-vin'-us*). [Latin, *lapis* = stone + *divinus* = divine.] A preparation of the following formula:

℞  
 Cupri Sulphatis.  
 Alum.  
 Potassii Nitratis, aa parts xxxii. (32).  
 Camphoris, " ii. (2).  
 M. Ft. lapidem.  
 Sig.—Apply to the lids or affected parts thrice weekly.

**Lapsus** (*lap'-sus*). [Latin, *labi* = a falling.] The drooping of the upper lid produced by a paralysis of the Levator palpebrae muscle. The condition is then known as Lapsus Palpebrae Superioris. This condition may also be brought about by hypertrophy of the upper lids. Synonym: **Ptosis**.

**Lash** (*lash*). [Middle English, *lashe* = a whip snap.] A name given to the long straight hairs of the eyelids. An eye winker; Eyelash.

**Latent** (*la'-tent*). [Latin, *latere* = to conceal] That which is not apparent or manifest. Latent Hyperopia is that variety of far sight in which the true state, or the extent of the state that is made manifest is not fully demonstrable by subjective means unless the mydriatic, atropine, is employed. This is carried out with the view of suspending the accommodation which, without this means, is in a state of hyperactivity and the muscle of accommodation is paralyzed in order that it may be in the state of rest so that when the vision is taken, the rays of

light from 20 feet or infinity, traveling in parallel paths, will pass through the dioptric mediae and, in an eye which is hyperopic, will meet as it were behind the retina with the muscle of accommodation in the state of suspension or at rest. It is this latency which baffles the efforts of those who depend upon the trial case alone for positive results, although it is largely overcome and very satisfactory examination results with the use of De Zeng's Refractometer. Here the actual amount of hyperopia is developed in a large majority of cases so that the optician can prescribe with a greater degree of confidence than he otherwise could. In Latent Hyperopia the rule adopted by English ophthalmologists is to prescribe one-third of the latent added to the manifest. The American rule is to prescribe one-half of the latent added to the manifest; but in either case the rule is an empirical one, so that it is a matter of considerable importance to prescribe lenses for just the actual amount of hyperopia the patient requires. De Zeng's Refractometer is the ideal means for prescribing lenses for patients where latencies exist, especially in those who are under the sixteenth year. Latent Strabismus or Squint applies to those cases wherein there is a tendency of the eyes to turn away from parallelism. Some of the varieties which come under the heading of heterophoria are esophoria, exophoria, hyperphoria, hyperesophoria or hyperexophoria.

**Law** (*law*). [Middle English, *lawe* = law, rule or principle.] A principle or rule laid down as the result of observation of natural phenomena. Donder's Law establishes the fact that presbyopia is due to a progressive hardness of the crystalline lens, in consequence of which there is a lack of corresponding elasticity of that body together with an inability of the muscle of accommodation to render the crystalline lens as convex for the near point as it should be; we are therefore obliged to prescribe convex spherical lenses which will make up for the convexity of the crystalline lens so that a patient may read, other things being equal, the finest print (Jaeger No. 1) at the range of fourteen inches without extra effort and for an indefinite period of time. From the foregoing fact, Donder's deductions are as follows: For every five years after the fortieth year an additional dioptr convex spherical lens will be prescribed for a presbyopic patient so that he may read with comfort at the range of fourteen inches.

DONDER'S LAW.

45 years of age	= + 1 Ds.
50 " " "	= + 2 Ds.
55 " " "	= + 3 Ds.
60 " " "	= + 4 Ds.

The above lenses will be sufficient for patients who are emmetropic, but an ametropic patient should first be corrected and then the above lenses should be prescribed in addition to the correction. Listing's Law relates to the muscles controlling the movements of the eyes, to the effect that the angle of rotation corresponds to a fixed axis which is perpendicular to the various positions along the visual lines. The Law of Refraction propounds that a ray of light traveling in an oblique path from a rare to a denser media will bend

in a line towards the perpendicular; and that a ray of light passing from a denser to a rarer media will bend in a line away from the perpendicular.

**Layer** (*lay'-er*). [Middle English, *leyer* = layer.] A stratum having a certain amount of thickness and serving the purpose of a covering. Bowman's Layer is the second layer of the cornea, the anterior lamina (Valk). The three coats or tunics which envelope the eye, the sclerotic, choroid and the retina, are sometimes called the Three Layers of the Eye. The retina consists of ten layers (Gray), the chief of which is the layer of rods and cones or Jacob's membrane.

**Left** (*left*). [Middle English, *left* = the left side.] This word or its initial *L* is used instead of the words *oculus sinistra*, to in-

dicate a lens for the left eye. A prescription may be formulated as follows:

R  
R. + 2. Ds.  
L. + 2. Ds.

**Lema** (*le'-ma*). [Greek, *leme* = catarrhal fluid.] The dry, hard, yellowish-white incrustations which collect in the inner canthus.

(To be continued.)

**Fallacies About the Eye.**

[From Philadelphia Medical Journal.]

**N**ONSENSE science about the eye seems to be possessed of the proverbial nine lives of the mythical cat. How-

ever absurd, however frequently disproved, the stories reappear with the pertinacious vitality and regularity that is inexplicable. Of no other organ are these popular superstitions and fallacies so prevalent. A brief review of a few may prove interesting.

Nonsense No. 1.—For centuries novelists and story tellers have been utilizing the tale of the image of the murderer photographed upon or in the eye of the murdered man. In the last years two novelists have repeated it, and in the newspapers it often crops up with comic innocence and solemnity. Of course no image can be formed on or in the cornea or on the iris if the laws of optics are true, and without an ophthalmoscope no eye except that of the novelist could see the retina, and if by death there were an image fixed there (which there is not) it could not be seen by another eye aided or not by the arts of dissection, photography and microscopy.

Nonsense No. 2.—A novel has recently been issued from the press of a New York publishing house for which the professional title of the author may give authority to the pseudo-science which, somewhat like the nonsense photography mentioned, has a fairylike ability to revive after death. The plot of the novel turns on the absurdity that the brain cells have the power to retain impressions like a photographic plate.

Nonsense No. 3.—Even in the most serious of newspapers (perhaps also in some medical journals) there has been lately appearing a grave scientific explanation of the snakes seen by patients with delirium tremens. This consists in the fact that some oculist has reported the retinal vessels in the disease to be increased in size and tortuosity. A "jump" is then made to the supposition that the snakes are the images of these tortuous and overfilled vessels. The vessels of one's own retina are invisible except by a little device of which the drunkard knows nothing.

Nonsense No. 4.—Pseudo-scientific persons are fond of rediscovering the old bit of dogmatism that the eyes, per se, have no "expression"—that is, apart from the emotions indicated by the rest of the face. Last year one of the most self-satisfied essays of one of the most self-satisfied of English essayists was devoted to showing up what he supposed the pitiable fallacy of the whole world that the eye does have the power of expressing feeling. But what an utterly different expression does mydriasis give not only to the eyes but to the entire face! Pupillary diameters and mobilities are most sensitively obedient to the play of the emotions, and they who do not recognize this must be strangely unobservant.

Nonsense No. 5.—Although anyone can be made to see them, so few indeed have ever observed what the oculists called *muscae* that when the first happen to catch a glimpse of the filmy dots and strings floating across a page or a cloud they are frightened. Quacks set a great store by these "black specks" and treat the poor worried patients for months with medicines and lotions. *Muscae* have no pathologic significance whatever unless, perhaps, occasionally to the disordered imagination of a dipsomaniac.

# The "Bryant" Rings.

ARE KNOWN TO THE JEWELER'S CUSTOMERS AS THEY ARE TO THE JEWELER, HAVING FOR 50 YEARS OCCUPIED THE PROUD POSITION OF "THE BEST."



THE "BRYANT" MARK IS ACKNOWLEDGED TO BE A GUARANTEE OF QUALITY, STYLE AND FINISH.

GOODS SENT ON APPROVAL TO RESPONSIBLE DEALERS.  
Our new Fall line comprises a profusion of new designs.

## M. B. Bryant & Co.,

10 Maiden Lane, New York.

### SLEEVE LINKS,

Moonstone, Amethyst, Carbuncle,  
Jade, Opal.

## GEO. O. STREET & SONS,

24 JOHN ST., NEW YORK.

... Established 1837 ...



## Eliassof Bros. & Co.,

IMPORTERS AND JOBBERS OF

### DIAMONDS, WATCHES, JEWELRY,

9-11-13 Maiden Lane,

Materials, Tools and Optical Goods.

NEW YORK.

ALBANY OFFICE: 62 & 64 STATE STREET.

**Workshop Notes.**

**To Color Inferior Gold.**—Dissolve saltpetre, 2 parts; alum, 1 part, and sea salt, 1 part, in a sufficient quantity of distilled water, and boil the gold in it to dryness.

**Solders for Aluminium.**—Strong—Gold, 89 grammes; fine silver, 5 grammes; copper, 6 grammes. Medium—Gold, 54 grammes; fine silver, 27 grammes; copper, 19 grammes. Weak—Gold, 14 grammes; silver, 57 grammes; copper, 15 grammes; brass, 14 grammes.

**Process for Blueing Small Articles of Steel.**—Heat an iron bar to redness and lay it on a receptacle filled with water. On this bar place the objects to be blued, with the polished side up. As soon as the article has acquired the desired color cause it to fall quickly into the water. The pieces to be blued must always previously be polished with pumice stone or fine emery.

**Powder for Silvering Copper.**—Carbonate of lime, 30 grammes; cyanide of potassium, 13 grammes; crystallized nitrate of silver, 8 grammes. Reduce all to a very fine powder and put in well closed bottles. For use take a small cotton wad, charge it with water and then with the powder and rub the piece to be silvered with it. The object to be silvered must be well cleaned previously. When the silvering is done wash in hot water and dry in sawdust.

**To Blanch Silver.**—Mix powdered charcoal 3 parts, and calcined borax 1 part, and stir with water so as to make a homogeneous paste. Apply this paste on the pieces to be blanched. Now put the pieces on a charcoal fire, taking care to cover them up well; when they have acquired a cherry red, withdraw them from the fire and leave to cool off. Next place them in a hot bath composed of 9 parts of water and 1 part of sulphuric acid, without causing the bath to boil. Leave the articles in for about one hour. Remove them, rinse in clean water and dry.

**Some Colored Alloys of Gold.**—Blue—Fine gold, 75; iron, 25.

Color of dry leaves—Fine gold, 70; fine silver, 30.

English white—Fine gold, 75; fine silver, 15; rose copper, 10.

Dark gray—Fine gold, 94; iron, 6.

Pale gray—Fine gold, 191; iron, 9.

Red—Fine gold, 75; rose copper, 25.

Pink—Fine gold, 75; fine silver, 20; rose copper, 5.

Sea green—Fine gold, 60; fine silver, 40.

Cassel yellow—Fine gold, 75; fine silver, 12½; rose copper, 12½.

The above figures are understood to be by weight.

**To Bleach Ivory.**—Like mother-of-pearl, ivory is readily cleaned by dipping in a bath of oxygenized water or immersing for 15 minutes in spirits of turpentine, and subsequently exposing to the sun for 3 or 4 days. For a simple cleaning of smooth articles wash them in hot water, in which one has previously dissolved 100 grammes of bicarbonate of soda per liter of water. To clean carved ivory make a paste of very fine, damp sawdust and put on this the juice of one or two lemons according to the article to be treated. Now

apply a layer of this sawdust on the ivory, and when dry brush it off and rub the object with a chamouis.

**Gilt Zinc Clocks.**—It frequently happens, says M. Bourdais, a French author, that clocks of gilt zinc become covered with green spots. To remove such spots the following process is pursued: Make a small wad of cotton, which is soaked in alkali and rub it on the spot. The green color will disappear at once, but the gilding being gone on that spot, a black place will remain. Wipe off well to remove all traces of the alkali. To replace the gilding put on, by means of liquid gum arabic,

a little bronze powder of the color of the gilding. The powdered bronze is applied dry with the aid of a brush or cotton wad. When the gilding of the clock turns black or too old it may be revived by immersion in a bath of cyanide of potassium, but frequently it suffices to simply wash it with a soft brush in soap water with plenty of lather, in which a little carbonate of soda has previously been dissolved. Brush the piece in the lather, rinse in clean water and dry in pretty hot sawdust. The piece should be dried well inside and outside, as moisture will cause it to turn black.

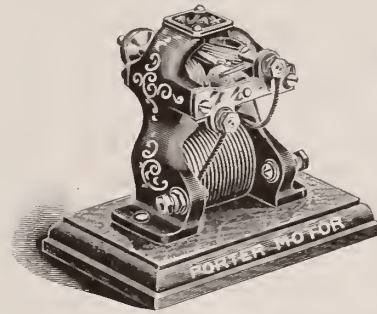

**K&D.**  
**Staking**  
**Tools**  
**AND**  
**BATTERY**  
**MOTORS.**

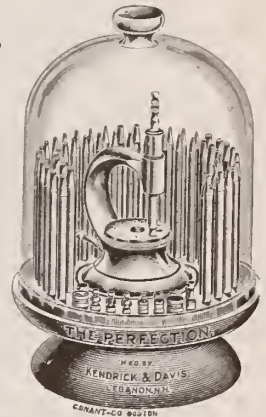

**WATCHMAKERS TOOLS.**



**KENDRICK & DAVIS, + LEBANON, N.H.**

**American Tools are the Cheapest**

Because they are the Best  
and Parts can always be duplicated quickly.

**FOR SALE BY ALL JOBBERS.**

**SEND FOR OUR NEW ILLUSTRATED CATALOGUE.**

**Our Hand-made Cases**

are constructed in the old reliable way, which is a pride to the Manufacturer, Dealer and Wearer.



ALL CASES BEARING THIS MARK,  
ARE HAND-MADE.



Manufactured by

**DUBOIS WATCH CASE CO.,**

Makers of **SOLID GOLD CASES.**

21 and 23 Maiden Lane, New York.

**Stern Bros. & Co.,**

Cutters of . . .

MANUFACTURERS OF

**DIAMONDS,** Gold Rings and Thimbles,

68 NASSAU STREET, NEW YORK.

RING FACTORY, 33-43 GOLD STREET, NEW YORK.  
DIAMOND-CUTTING WORKS, 142-146 W. 14TH ST., NEW YORK.

LONDON OFFICE, 29 ELY PLACE.  
CHICAGO OFFICE, 149 STATE ST.

# BRADLEY & HUBBARD MFG. CO.

Have produced for this season's trade  
the finest line of goods ever offered.

## Art Metal Goods,

PITCHERS, VASES, CANDELABRAS,  
FIGURES, BUSTS, TABLES, ETC.....

## Reception Lamps

WITH THE CELEBRATED "B. & H." and B. & H. RADIANT BURNERS.  
NEW AND ORIGINAL DESIGNS.  
HANDSOME AND EXCLUSIVE FINISHES.

*Dealers are cordially invited to inspect the line of Samples  
at our SALESROOMS.*

**NEW YORK:** 26 Park Place to 21 Barclay Street.

**BOSTON:**  
160 Congress Street.

**CHICAGO:**  
131 Wabash Avenue.

**PHILADELPHIA:**  
714 Betz Building.

**FACTORIES and OFFICES: MERIDEN, CONN.**

# CROUCH & FITZGERALD,

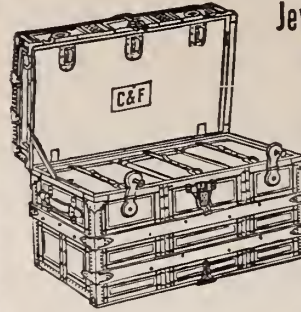

Jewelry Trunks  
and Cases,  
161

Broadway,  
Bet. Cortlandt and  
Liberty Sts.

688 B'way,  
723 6th Av.  
NEW YORK.

For Length and Quality  
of Service the  
**Remington**  
Standard Typewriter  
defies competition

Established 1879.

**LOUIS W. HRABA,**



Manufacturer of  
**Fine Leather Goods**

29 East 19th St., New York.

Exclusively for the Jewelry Trade.

# WOOD & HUGHES,

Sterling Silverware Manufacturers,

FINE PLATED WARE,

No. 24 John Street, - New York.



# THE F. KROEBER CLOCK CO., IN LIQUIDATION

ARE DISPOSING OF THEIR LARGE STOCK OF  
CHOICE

## Eight-Day and One-Day Clocks

CONSISTING OF

Porcelain, Iron, Bronze, Gilt and  
Wood Clocks

AT A

## REDUCTION

INSTEAD OF AN ADVANCE.

SALESROOMS AT

**360 BROADWAY, - - NEW YORK.**



### The Rambler's Notes.

WHAT THE RAMBLER SAW AND HEARD AMONG THE DEALERS IN ART POTTERY, CUT GLASS, BRONZES, ETC.

POPULARITY OF ROYAL COPENHAGEN WARE.

THE beautiful pottery of the Royal Copenhagen Porcelain Co. has, this season, been meeting with more than usual success in the hands of jewelers of this country, and this despite the fact that novelties in this ware have not been as numerous as formerly. The ware next year, however, promises to contain a fine variety of new pieces upon which the company have been working for some time, and which they will bring out at the Paris Exposition. Their exhibit at Paris, it may be incidentally remarked, will eclipse any they have made at previous expositions, and arrangements have been made to enable Americans visiting Paris to have goods purchased there delivered to them in this country without bother or expense.

NEW EFFECTS IN CAMEO WARE.

IN the Cameo ware, at present so popular, are some pleasing effects in new plaques in which the body color is a deep green. These plaques, like their predecessors, are in rococo shapes, but the high relief figure work shows new designs as well as the former popular subjects taken from nudes in celebrated paintings. Religious subjects are also among the new pieces. Bawo & Dotter, 26-32 Barclay St., New York, by whom these goods are now shown, have also a number of vases, urns, comports and epergnes in the same ware. Prominent in this pottery are some vases in the shapes and styles of well known Capo di Monte pieces, only instead of the colored figure decorations, there are bands of white cameo figures on a solid green ground.

THE FINER GRADE OF TEPLITZ WARE.

AS an example of the artistic properties of the finer grade of Teplitz pottery no better line could be instanced than that containing the vases embodying a raised lily decoration in combination with a body color comprised of shaded purple, green and ivory. In these the motif of the flower design is carried out perfectly throughout each piece, in the shape, in the coloring and in the general effect.

The line is now to be seen at the ware-rooms of C. L. Dwenger, 35 Park Place, New York, who is showing, among other lines especially suitable for the holiday season, a collection of new handkerchief, glove, trinket, bonbon and jewel boxes. These boxes are of porcelain, having on a matt olive ground a decoration of white scroll work in relief. Some of the smaller pieces also show white cameos of cupids, heads and busts.

THE RAMBLER.

#### Export Tax on Mother-of-Pearl in Tahiti.

WASHINGTON, D. C., Nov. 9.—Under date of Dec. 14, 1898, Vice-Consul Hart transmitted a report to the State Department from Tahiti concerning the proposed export tax upon mother-of-pearl shells. Consul Jacob L. Doty writes from Tahiti under date of Aug. 15 as follows:

I have now to inform the department that on the 14th instant a decree was promulgated at the instance of the President of the Republic of France, establishing an export duty of 15 francs (\$2.89) per 100 kilograms (220.46 pounds) upon all mother-of-pearl shells exported from this colony. This tax, however, is to be refunded upon the production of a certificate from the customs authorities in France, showing that the shells have been entered at a French port and declared for consumption.

This measure was adopted in the hope that it might stimulate trade between France and this distant colony. The opinion prevails here, however, that the duty imposed is too low to force the shipment of Tahiti shell to France, and that it will result only in hardship for divers, should merchants combine and deduct the amount of the tax from the price paid for the shells at the fisheries.

It is claimed, moreover, that France is not the best market for Tahiti pearl shells; and that the variety produced here (black edge) has in the past found but limited demand there, and in consequence large shipments to France would be unprofitable. Notwithstanding the export duty, Tahiti pearl shells will find their way to the London market, which has for many years been the distributing point for the world's supply of mother-of-pearl shells.

This tax will have no considerable bearing, if any, upon the trade of the United States. Large quantities of shells are shipped through the United States in transit to London, and this will probably continue. I am informed that notwithstanding the fact that Tahiti shells can be purchased (by arrangement) at New York before transshipment, buyers in the United States rarely avail themselves of the opportunity, but usually secure their supply from London.

#### A Hat of Diamonds.

SIR JUNG BAHAHUR, the Prime Minister to the King of Nepal, has a hat made of diamonds worth over £500,000 and perched on top is a single ruby of incalculable value.—*Tid-Bits.*

### OLD BRITISH POTTERY MARKS

HOW TO IDENTIFY 17TH CENTURY AND 18TH CENTURY CHINA AND PORCELAIN.

AS jewelers often have specimens of old English china and porcelain brought under their notice, either for purchase or to value or identify, the following list compiled by the *Pottery Gazette* will be found useful:

**Etruria Ware.**—All specimens, trial pieces excepted, produced during the lifetime of Josiah Wedgwood, are stamped with either of the following marks:—

WEDGWOOD, in capital letters.	} Before 1768 and after 1780.
Wedgwood, in small letters.	
Wedgwood, Etruria (rare).	} Only on ornamental pieces made between 1768 and 1780.
WEDGWOOD & BENTLEY, in capital letters.	
Wedgwood and Bentley, in small letters.	
Wedgwood and Bentley, Etruria, in circle.	} and intaglios.
W. and B., on small seals	

Sometimes a small mark or a capital letter is found besides the name. The stamps with which these marks were impressed in the clay are clearly and sharply cut.

**Liverpool Pottery (1716 to 1722).**—Pottery printed in Liverpool is in rare instances inscribed with the name of "SADLER," or "SADLER AND GREEN." The Herculanum pottery was originally started in 1794.



Fig. 1. Fig. 2. Marks on Herculanum Pottery before 1822.



Fig. 3.—Case, Mort & Co.'s mark on Herculanum Pottery.

The earliest mark of this ware was "HERCULANEUM," printed in blue (Figs. 1 and 2).

From 1822 until 1833 the words "HERCULANEUM POTTERY" were stamped or marked on some conspicuous part of the ware.

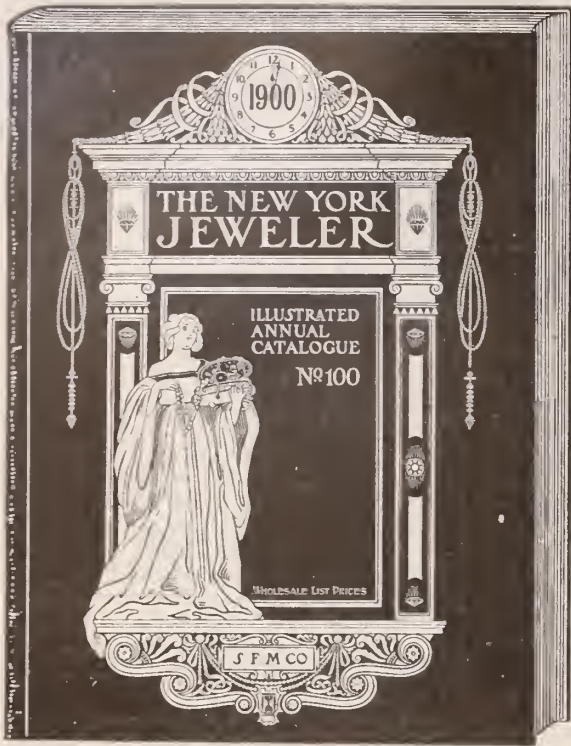

ILLUSTRATION 16 SIZE.

**S. F. MYERS CO.,** *Manufacturers, Importers*  
and *Wholesale Jewelers,*

MYERS BUILDING, 48 & 50 MAIDEN LANE, 33 & 35 LIBERTY STREET, N. Y.

Address Department No. U 10 when sending for catalogue.

# OUR NEW CATALOGUE

Just out.  
List Prices Only.

**724 PAGES, 9 x 13.**

For 26 years the acknowledged authority for choice designs in reliable goods and the lowest prices current in the New York market.

**WATCHES,  
DIAMONDS,  
JEWELRY,  
OPTICAL GOODS,  
SILVER NOVELTIES,  
MUSICAL MDSE.,**

**Clocks, Lamps,  
Cut Glass, Silverware,  
Fine Leather Goods  
And Stationery,  
Photographic  
Supplies,  
Jewelers'  
Sundries, Etc.**

Messrs. Case, Mort & Co. adopted the crest of the borough of Liverpool as their mark (Fig. 3).

**Yorkshire Pottery** (1665 to 1728).—Although the Leeds ware is but rarely marked, some specimens bear the name of the pottery impressed in full, "LEEDS POTTERY." In a few cases, "HARTLEY, GREENS, CO., LEEDS POTTERY."

The letters C G (Charles Green), G and crown (Fig 4), and an arrow's head (Fig. 5), on cream colored faience, are likewise considered as early Leeds marks.

Leeds Pottery.  
Leeds Pottery.



Fig. 4.



Fig. 5.

EARLY MARKS ON LEEDS POTTERY.

(To be continued.)

### New Safety Watch Chain.

**D**ETEKTIVE-SERGEANT JOHN J. FOGARTY, one of the ablest of Captain McClusky's staff of detectives, of New York, has just had patented a safety guard for watches, concerning which he says:

"In most cases when watches are stolen by pickpockets the watch is either separated from the pendant ring by twisting the ring off the pendant or the watch chain and watch are together removed from the waistcoat and waistcoat pocket, which operation is called by pickpockets 'removing the entire front.' This invention is designed to prevent the stealing of the watch alone or watch and chain together by pickpockets by connecting the watch with the waistcoat by means of a comparatively simple attachment, so that the pull caused by removing the watch or chain will immediately disclose the attempt of the pickpocket, so that he may be caught. The invention consists in the combination, with a garment provided with a pocket and a hole or eyelet in the rear wall of the pocket and in the lining of the garment, of a safety guard chain adapted to pass through the holes or eyelets, means for attaching the guard chain to a watch, and means for attaching the guard chain to a garment. This eye may be in the form of a screw-eye screwed into the case or a ring secured by a small screwbolt and nut, but is permanently attached to the case, so as not to be removed by ordinary use or by any manipulation of one attempting to steal the watch. When the safety attachment is applied to a watch and waistcoat, it is obvious that any attempt to remove 'the entire front,' the combined watch and chain, from the waistcoat, which is the most clever trick of the pickpocket, is immediately frustrated by the tug which is exerted on the waistcoat by the auxiliary safety guard chain, whereby the attempt at stealing the watch is immediately indicated, so that the pickpocket can be arrested and the taking of the watch prevented."

## PAIRPOINT MFG. CO.

New Bedford, Mass.

**LATEST CONCEPTIONS**

....IN....

**Rich Cut Glass,**

**Silver Plate**

.. AND ..

**Table Ware.**

38 Murray St., New York City.

Temple Building, Montreal.

**ALOIS KOHN & CO.,** 4 MAIDEN LANE, SOLID GOLD CHAINS, Near Broadway, N. Y.

We call the attention of the Trade throughout the country to our line of

### LORNETTE AND GUARD CHAINS.

Will send Samples on Memorandum on receipt of satisfactory reference. Correspondence Solicited.



SAMPLE OF ENGRAVING DONE ON THE  
**Eaton-Engle Engraving Machine.**

CATALOGUE AND SAMPLE OF WORK FREE.

**EATON & GLOVER** have removed to the FULTON BUILDING,  
87 NASSAU ST., Cor. Fulton, N. Y.



# Stella Music Boxes

ARE UNEQUALED FOR

Sweetness,  
Harmony and  
Volume

of tone, and have smooth  
metallic tune sheets playing  
thousands of tunes.

**Why Not** handle a line of Music Boxes the sale of which you can control and **Make Money?**

WRITE FOR CATALOGUE AND TERMS.

**Jacot & Son,** 39 UNION SQUARE,  
NEW YORK.

**W. C. A. WESTPHAL,**  
WATCHMAKER,

41 Maiden Lane, NEW YORK.

Established 1892. Telephone, 3684 Cortlandt.  
Estimates, Repairing, Adjusting of Chronometers, all  
Complicated Watches and Fine Time Pieces.

**DEMAGNETIZING.**

Watches made Non-Magnetic.  
Fine Wheel and Pinion Cutting

American  
Watch Case Co.,

**A.W.C.CO**

9-11-13 Maiden Lane,

Gill Building, New York.

**FERD. FUCHS & BROS.,**  
**SILVERSMITHS,**  
MAKERS OF STERLING SILVERWARE,  
34 East 29th St., - New York.

**Edward N. Cook,**  
**GOLD & SILVER PLATE**

Plated Seamless Wire  
and Aluminum Solder.

144 PINE ST., PROVIDENCE, R. I.

**ESSER & BARRY,** Largest Manufacturers of  
IMITATION DIAMOND JEWELRY Cheap and Medium Priced  
IN AMERICA.

Write us for samples of almost anything with an Imitation Diamond in it.  
MAIN OFFICE AND FACTORY, 101 SABIN ST., PROVIDENCE, R. I.



"Buy direct from the manufacturer and get  
all that is coming to you."  
SEND FOR OUR "HOT CATALOGUE, CONTAINING  
COLD FACTS AND PRETTY PICTURES."  
**CLARK & COOMBS,**  
86 WEST EXCHANGE ST., - PROVIDENCE, R. I.

WE ARE  
HEADQUARTERS  
FOR.....  
**Gold  
Shell  
Rings...**

**AIKIN, LAMBERT & CO.,**  
MANUFACTURERS OF  
FINE GOLD PENS, HOLDERS, PENCILS,  
TOOTH PICKS and NOVELTIES.  
PAUL E. WIRT FOUNTAIN PENS, at new and lower prices . . .  
MERCANTILE FOUNTAIN PENS, guaranteed to give satisfaction.  
Catalogues with terms and discounts furnished to the trade.  
BRANCH, 103 STATE STREET, - - - CHICAGO.

**AIKIN-LAMBERT JEWELRY CO.,**  
IMPORTERS OF  
**DIAMONDS.**  
JOBBER IN  
WATCHES, JEWELRY, CHAINS,  
NOVELTIES, ETC.  
LATEST DESIGNS. LOWEST PRICES.  
**19 MAIDEN LANE, NEW YORK.**

# CHAS. F. WOOD & CO., DIAMONDS

1 MAIDEN LANE, NEW YORK.

IMPORTERS AND CUTTERS.

## DIAMONDS.

LARGE ASSORTMENTS.

DESIRABLE SIZES.

ATTRACTIVE PRICES.

**R., L. & M. FRIEDLANDER,**

30 MAIDEN LANE, N. Y.

97 HATTON GARDEN, LONDON.

## HALL CLOCKS,

*Mantel Clocks,  
Traveling  
Clocks,  
Clock Sets,  
Regulators,  
Bronzes,  
Vases, Ivory  
Miniatures  
and Art Goods.*



Fall Line Now Ready.

**Harris & Harrington,**

32 and 34 VESEY ST., NEW YORK.

Sole Agents to the Trade for J. J. Elliott & Co., London.

## HOROLOGICAL DEPARTMENT,

BRADLEY POLYTECHNIC INSTITUTE,

PEORIA, ILLINOIS.

Largest and best watch school in America. We teach Watch Work, Jewelry, Engraving, Clock Work, Optics. (Formerly Parsons' Horological Institute.) Catalogue Free.



## 37 YEARS OF HONEST RETURNS

IS OUR GUARANTEE OF SATISFACTION TO ALL OUR CUSTOMERS.

WE DO OUR OWN SMELTING,

**JOHN AUSTIN & SON,**

ASSAYERS, REFINERS AND SMELTERS,

74 & 76 Clifford St., Providence, R.I.

## CUT GLASS

Whiskey Bottles,

Brandy Bottles,

Clarets, Decanters,

with and without

Silver Mounts.

ABSOLUTELY NEW  
GOODS PARTICULARLY  
ADAPTED FOR MEN.

**LE BOUTILLIER & CO.**

18 East 17th St., New York.



GOLD AND SILVER PENCILS,  
PENHOLDERS, &c.

**FAIRCHILD & JOHNSON CO.**

Office and Factory,  
220 FOURTH AVENUE, N. Y.

## Satisfaction

AND....

## Promptness

is the secret of our success. Our chief aim has always been to render prompt returns and to give satisfaction to all our customers.

**CONLEY & STRAIGHT,**

GOLD AND SILVER

REFINERS, ASSAYERS and  
SMELTERS,

236 Eddy Street, PROVIDENCE, R. I.



No. 1946. No. 1947. No. 1948.

Factory, 100 STEWART ST., PROVIDENCE, R. I.

New York Office, 11 John St.

Chicago Office, 131 Wabash Ave.

A COMPLETE LINE OF  
**FRIENDSHIP HEARTS AND LUCKY BANGLES**  
FOR HOLIDAY TRADE.

**S. & B. LEDERER CO.**

## EMPIRE COMBS. SIDE COMBS.

GOLD AND JEWELLED ORNAMENTED.

SPECIALTIES IN ROMAN WORK.

**DAY, CLARK & Co.,**

MAKERS OF FINE JEWELRY,

23 MAIDEN LANE, N. Y.

**PROV. STOCK CO.** HIGH GRADE ROLLED PLATE  
Chains

BRACELETS, LORGNETTES.

10K. GOLD

Scarf Pins, Brooches,  
Neck Chains, Lorgnettes,  
Bracelets.

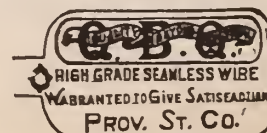

IMPORTERS AND CUTTERS OF DIAMONDS  
**Arnstein Bros. & Co.**  
 65 Nassau St. NEW YORK.  
 Cor. John.

**DIAMONDS** Importers and Cutters.  
**L. & M. KAHN & CO.,**  
 172 Broadway,  
 Cor. Maiden Lane, N. Y.  
**DIAMONDS**



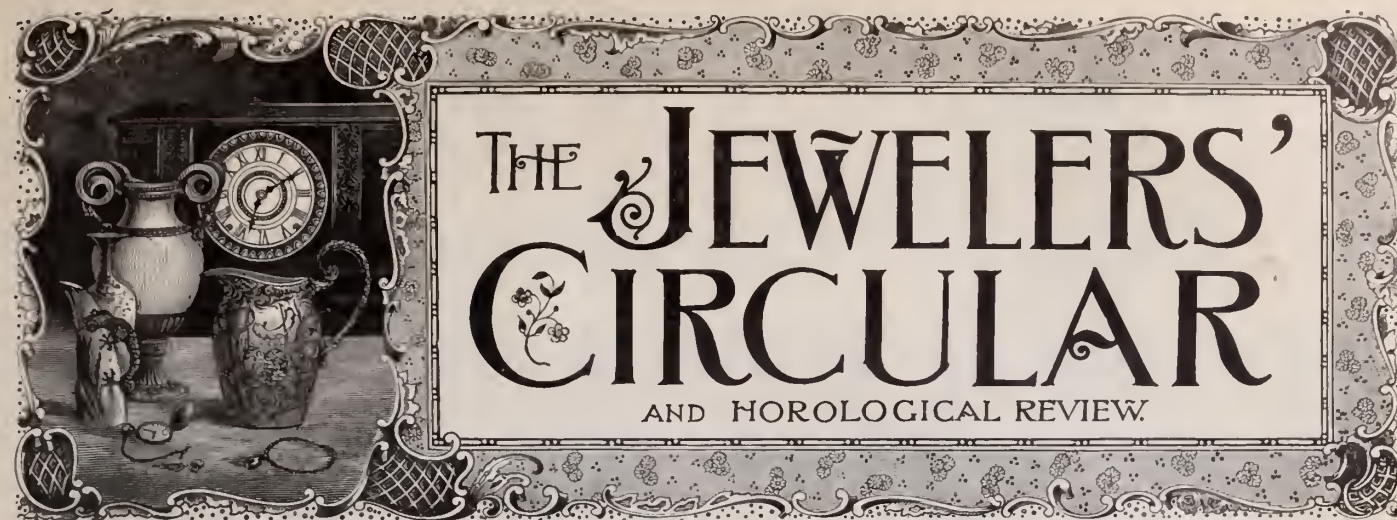

Corbin Building, 11 John St., Corner Broadway, New York.

Copyrighted by THE JEWELERS' CIRCULAR PUB. CO.

Entered at the Post Office in N. Y. as second-class matter.

VOL. XXXIX.

NEW YORK, WEDNESDAY, NOVEMBER 22, 1899.

No. 17.

## THE INCREASING CUSTOM OF PRESENTING LOVING CUPS.

THE custom of presenting loving cups, which has been growing from year to year, is in greater favor at the present time

than ever before, evidence of the extent to which this custom is now carried being found on every hand. One of the latest notable instances was the presentation of a massive loving cup to President Fordyce, of the St. Louis and Southwestern Railroad, by the employes of that company. The cup for this occasion was ordered through R. H. Stearns & Co., Pine Bluff, Ark., and was made by the Mauser Mfg. Co., New York. The cup is a massive piece of sterling silver, 24 inches high and weighing about 230 ounces. The decorations, simple yet rich, are most appropriate to the occasion of the presentation and are thoroughly emblematic. At the center of the cup is a bulbous band divided into six sections. Three alternate ones are at the mouths of cornucopias, which form the handles of the cup. The other sections between these

handles show handsomely etched panels containing the inscription, a cotton scene, and a railroad scene. At the base are

three beautiful figures in *haut relief*, typifying first, mining, second, machinery, and third, agricultural commerce.

the inscription bears the words: "Presented to President Col. Samuel W. Fordyce By Friends and Co-laborers of The St. Louis and Southwestern Railroad, 1899."



EMBLEMATIC LOVING CUP PRESENTED TO PRESIDENT FORDYCE, OF THE ST. LOUIS AND SOUTHWESTERN R. R.

The remainder of the decoration is in pure rococo style, and the piece is entirely in gray finish. The panel containing

knot of white diamonds. Another handsome ring has three diamonds of as many different colors, pink, green and yellow.

## The Jewels of Menelek

THE Emperor Menelek continues his orders, and has the ambition to form a crown of incomparable jewels. Necklaces for himself and his wife, bracelets to adorn the wrists, the arms and the ankles, rings in large quantity, diadems with very beautiful diamonds, have been selected from the richest samples. The Empress Taiton, according to the latest eccentric fashion, will receive 16 diamonds specially prepared to be inserted in false teeth. As a detail of luxury not yet adopted by Parisians, superb diamond-gaiters will complete her adornment.

Julia Arthur, the actress, is said to have a very beautiful and unique ring. It has a canary colored diamond in the shape of a heart set in a bow-

# Our New Lines For The Spring Trade

will be ready right after Christmas, and as we are sparing no effort or expense to bring them to perfection they will be lines not surpassed by any on the market during the season. The quality will be up to our usual high standard of rolled-gold plate, while the finish is the finest that can be produced.

LOCKETS, CHARMS, BRACELETS, CHAINS, PINS, EARRINGS, SILK VEST CHAINS and HAIR CHAIN MOUNTINGS; also a large variety of those dainty little BROOCHES now in vogue, and an enlarged line of BUCKLES.



Do not allow your stock of STERLING SILVER TOILET and MANICURE GOODS and NOVELTIES to get too low, as you will have a good demand for them all through the Holiday Season.

OUR CATALOGUE IS YOURS FOR THE ASKING.

**THEODORE W. FOSTER & BRO. CO.,** 100 RICHMOND ST., PROVIDENCE, R. I.  
Successors to FOSTER & BAILEY.



## A USEFUL NOVELTY

### Bottle Openers,

in Sterling Silver and Silver Plate. The convenience and cleanliness of this form of bottling having brought it into general use, these Openers will be appreciated for the table. Send for catalogue.

MADE BY

**Goodnow & Jenks,**

**SILVERSMITHS,**

Stanhope and Morgan Sts.,  
Boston,

who have obtained the SOLE RIGHT from patentees to manufacture this article.



# The Best.

## The "DOUBLE-BASE" Engraving Block

shown upon this page is regarded by the users of the same as the best block for the price, viz.:

### \$15.00,

on the American market. The attachments, consisting of Spoon Holder, Button and Bangle Attachments, Ring Holder, Cement Plates, 8 sets (4 each) Pins and Pegs, and Leather Pad, are more than are given with any other block. It is a better finished block and more work can be done with the same than with any other block offered for sale.

### An Absolute Guarantee Is Given With Every Block.

In addition to the above attachments, we can furnish you with a Thimble Holder (2 pieces) for 50 cents; Cane and Watch-Cap Holder (4 pieces) for 75 cents; Cement Plates from 25 cents to 50 cents, and Polished Hardwood Base, with drawer and glass shade, for \$3.50.

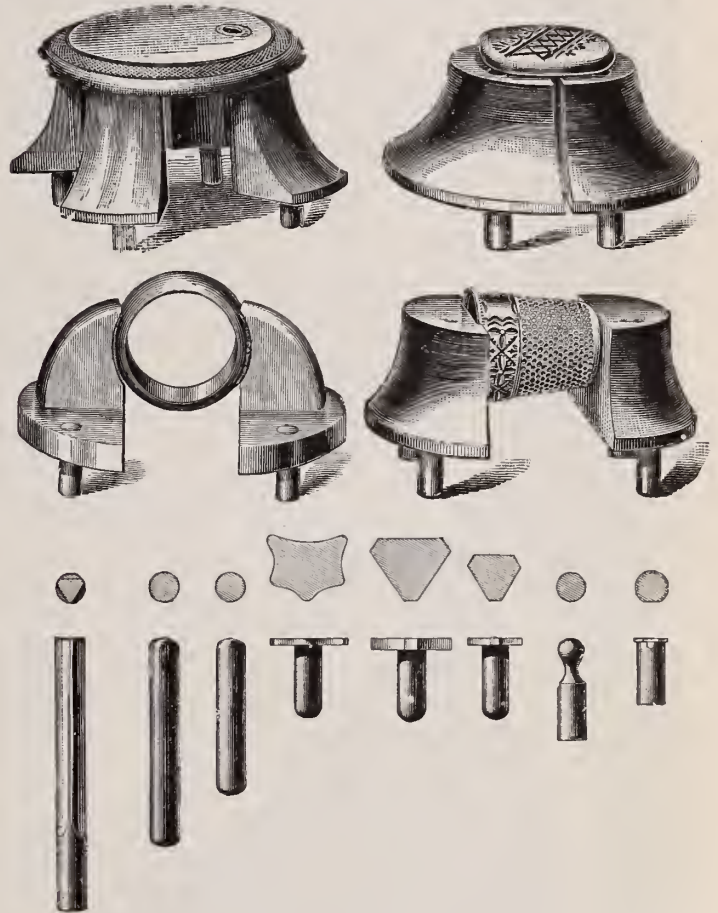
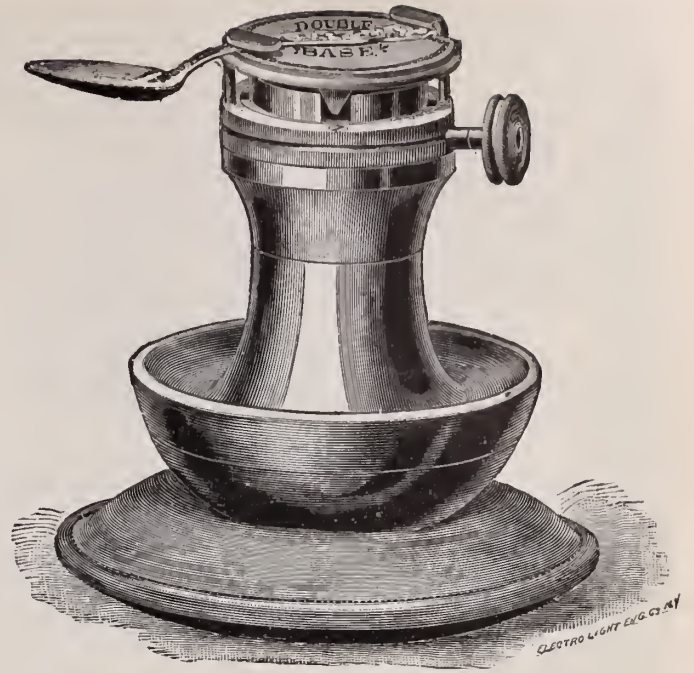

## L. C. REISNER & CO.,

Manufacturing Jobbers, Importers and Exporters,  
Watch Materials, Tools and Supplies,

Jewelry Repairers for the Trade.

LANCASTER, PA.



Our Trade-Mark  on all kinds of

**GOLD-FILLED CHAINS**

means that they **ARE BEST.**

Ask that our travelers call or send for selection package. Give us a way to convince you that what we say is so.

THE **BASSETT JEWELRY CO.,**

Successors to

The Kent & Stanley Co., Ltd.,

PROVIDENCE,

R. I.

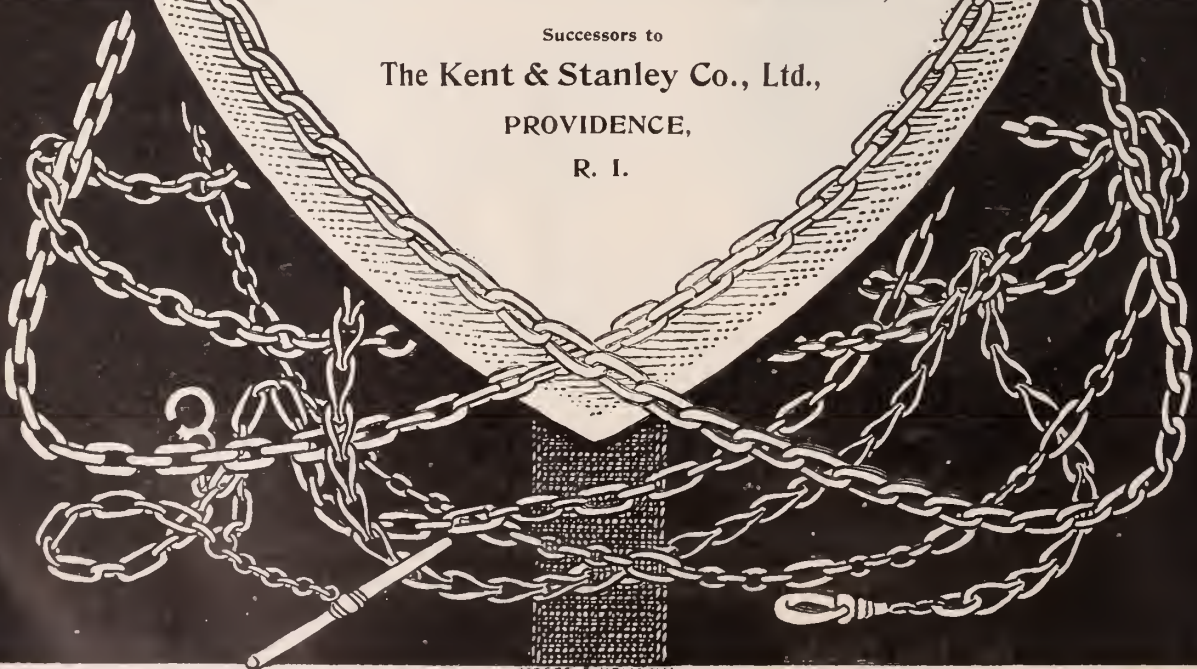



HIGHEST GRADE Silver-Plated Flat Ware Ever Manufactured in This or any Other Country.  
**THE ROGERS & HAMILTON CO.,**

New York:  
9-11-13 Maiden Lane.

Factory K, International Silver Co., Successor.

**WATERBURY, CONN.**

# WALTHAM WATCHES

*are the best and best-known watches  
in the world.*



Ralph Waldo Emerson,  
in his Essay on Elo-  
quence said in speak-  
ing of a man whom  
he described as a  
Godsend to his town,  
"He is put together like  
a Waltham Watch."



**Conditions in the Diamond Industry of Amsterdam.**

WASHINGTON, D. C., Nov. 14.—Consul Hill sends the following from Amsterdam, Oct. 18, 1899:

"The diamond trade in Amsterdam shows the effect of the war in its inactivity. Prices of rough diamonds, which for some time have been noted as rising at intervals of two months, have been marked up twice within the last eight days. The rise must restrict sales, since manufacturers will find it difficult to buy at the advanced prices."

Under date of Oct. 24, Mr. Hill adds: "The main reason for the great scarcity and high prices is the unusual demand from the United States and continental buyers. The whole output of the DeBeers mines is sold in March of each year; this year, the syndicate had to consent to an advance of 35 per cent. There is great difficulty in obtaining supplies, scarcely any parcels of less value than £5,000, or \$25,000, being sold."

**Activity in the Affairs of the Pennsylvania Optical Society.**

PHILADELPHIA, Pa., Nov. 15.—At the regular monthly meeting of the executive committee of the Pennsylvania Optical Society, held Tuesday, Nov. 14, R. S. Tozer was elected a member of the association. J. F. Brinkerhoff, West Philadelphia; H. W. Patterson, Salem, N. J., and F. B. Marchant, Brooklyn, N. Y., were elected members of the examining board to prepare questions and make all necessary arrangements for the examination of candidates for the dioptrician grade, to be held on the second Tuesday in March, 1900.

A. H. Peoples, Chester; D. V. Brown, Philadelphia, and G. F. Applegate were appointed to make arrangements for a public meeting of the society to be held the same evening, and to have papers on optical subjects prepared and read.

**American Clocks and Watches Made of Imported Material.**

WASHINGTON, D. C., Nov. 15.—Section 30 of the Tariff act provides that where imported materials on which duties have been paid are used in the manufacture of articles manufactured or produced in the United States there shall be allowed on the exportation of such articles a drawback equal in amount to the duties paid on the materials used, less one per centum of such duties. The Treasury Department has prepared an interesting table showing the operation of this section during the fiscal years of 1898 and 1899.

According to this table imported parts of clocks and watches to the value of \$2,656 were withdrawn from the warehouse at New York during 1898, upon which a drawback of \$659.83 was paid. In 1899 the same kind of material to the value of \$1,171.80 was withdrawn, upon which a drawback of \$649.67 was paid.

In 1898, 260,025 clocks and watches and parts of, manufactured from imported materials, were exported from the port of New York, the drawback aggregating \$1,151.61. During the last fiscal year the number exported was 148,153, and the drawback paid was \$1,145.15.

**Death of William J. Keith.**

WORCESTER, Mass., Nov. 17.—William J. Keith, for 50 years a resident of Southbridge and for many years engaged in the drug and jewelry trade in that town, died at the residence of his son, H. B. Keith, 10 Beaver St., this city, Wednesday, after a long sickness. He was born in Thompson, Conn., 81 years ago, and, after a short residence in New York, after graduating from school, went to Southbridge, where he engaged in trade, and was highly respected in that community. He retired from business five years ago on account of failing health.

**Mysterious Robbery of the Store of Gustav Huebner.**

MEMPHIS, Tenn., Nov. 16.—A peculiar and very mysterious robbery occurred last Tuesday night, with which the police expect to have some trouble. The store at 347 Main St. is occupied jointly by Gustav Huebner, watchmaker and jeweler, and the Idlewild greenhouse. Huebner occupies the north side of the store.

On the morning referred to, when the negro porter went to the store to make a fire and set things to rights, he found the front door open, and later, when Wm. H. Englehard, of the Idlewild greenhouse, came down, the porter was busy about his duties. The porter had no key to the store, and some one always lets him in.

When Mr. Huebner came down to his work he discovered that he had been robbed of some \$200 worth of sterling silver ware. The goods were spoons, forks, knives, etc., and were all contained in plush cases. In one or two instances where the solid ware was in the same case with plated ware, the thief took out the solid silver and left the plate. There was nothing broken open—no doors, windows nor show cases—and it is supposed that the door was opened with a skeleton key.

**Southbridge Optical Co. to Add a Grinding Department.**

SOUTHBRIDGE, Mass., Nov. 15.—The Southbridge Optical Co. are to add a grinding department to their works, and grind all lenses used for spectacles and eyeglasses. The company have always done edge-grinding, and now machine grinding will be introduced, and lenses will be ground and edged from the raw material. The Southbridge Optical Co. have always bought their lenses of the American Optical Co., but a sudden advance in prices warranted the company to grind their own lenses.



H £

We Manufacture  
 Knives, Forks, Spoons and Cutlery.  
 Hollow Ware, Toilet Ware and Manicure Pieces.  
 The Kind that is sought in Jewelry Stores  
 Not found elsewhere.

**HOWARD STERLING CO.**  
 Silversmiths.  
 Providence • New York • San Francisco

**WATCH CASE GUARANTEES.**

THE RETAIL JEWELERS SPEAK OUT AND GIVE THEIR IDEAS ON AN IMPORTANT MATTER BEARING UPON THEIR TRADE.

[This series of letters began in issue of Nov. 15.]

Millions of gold filled watch cases have been sold during the past quarter century, and the vast majority have outworn and will outwear the term of guarantee that originally accompanied them, but as the months pass by the exceptional instances where the gold shell of the case has been worn through, showing the interior base metal are, taking into consideration the constantly increasing sales, bound to multiply. Until quite recently dealers have had very little trouble with the cases returned by customers, but a natural interest exists throughout the retail jewelry trade as to the cases whose long term guarantees are nearing their end. The dealer feels no anxiety about a long term filled case that has been in use only a few years, but the nearer the day of maturity the more concerned he is that the wearer of the case may discern real or imaginary defects in the case sufficient to warrant his returning it to the dealer. It was upon the request of several responsible jewelers that THE CIRCULAR entered upon the undertaking of obtaining a consensus of opinion from the retail trade, and sent to a large number of jewelers, indiscriminately, a letter of which the following is a copy:

NEW YORK, Sept. 8, 1899.

WE ARE SENDING THIS LETTER TO THE RETAIL TRADE WITH THE OBJECT OF GETTING THEIR VIEWS ON AN IMPORTANT SUBJECT, NAMELY: THE GUARANTEEING OF FILLED WATCH CASES. FROM THE RESPONSES RECEIVED MAY BE EVOLVED SOME VALUABLE SUGGESTIONS.

OF THE FOLLOWING FORMS OF GUARANTEE, WHICH DO YOU CONSIDER MOST JUST, AND WHAT ARE YOUR ARGUMENTS ON THE SUBJECT?

1. SHOULD THE MANUFACTURER GIVE A NEW CASE OF THE SAME GUARANTEE IN EXCHANGE FOR THE OLD CASE THAT HAS NOT LIVED UP TO ITS GUARANTEE?

2. SHOULD THE MANUFACTURER EXCHANGE THE CASE THAT HAS NOT LIVED UP TO ITS GUARANTEE WITH ONE OF LOWER GUARANTEE? THAT IS, IF A 20-YEAR CASE HAS BECOME DEFECTIVE AT THE END OF 10 YEARS, SHOULD IT BE REPLACED WITH A 10-YEAR CASE?

3. SHOULD THE MANUFACTURER REPAIR THE CASE AND PUT IT IN CONDITION TO OUTLIVE THE UNEXPIRED TERM, IF THE CASE SHOWS THE BASE METAL BEFORE THE LIFE OF THE GUARANTEE HAS EXPIRED?

4. SHOULD HE GIVE A NEW CASE AND CHARGE FOR THE LENGTH OF TIME THE CASE THAT DID NOT LIVE UP TO ITS GUARANTEE HAS BEEN WORN; IN OTHER WORDS, REBATE FOR THE UNEXPIRED TERM OF GUARANTEE?

YOURS VERY TRULY,

THE JEWELERS' CIRCULAR PUB. CO.

All those jewelers who did not receive this letter are cordially invited to send their views upon this subject, replying to the questions seriatim or collectively. Their replies will receive the same measure of consideration as those received direct from the letters themselves. The more views on this subject expressed by the trade at large the more convincing will be the conclusions reached.

COUNCIL BLUFFS, Ia., Sept. 12, 1899.

Editor of THE JEWELERS' CIRCULAR:

In reply to your circular of Sept. 8, 1899, would say in reply to question No. 1, I think customers would be satisfied if they got a case that would last the balance of guarantee.

No. 2. Yes, if the gold is the same quality in the 10 year as in the old worn out case.

No. 3. There should not be any objection to the repairing of old case if it can be made to last the balance of the guarantee. It would discourage a lot of people from asking for new cases on account of very small defects.

No. 4. If the manufacturer don't want a lot of trouble he had better not think of charging. Any old thing will go with the public so long as it is free.

The customer could be given the option to pay difference for new case, or have the old one fixed up free. Yours truly,  
M. WOLLMAN.

PEKIN, Ill., Sept. 12, 1899.

Editor of THE JEWELERS' CIRCULAR:

Am pleased to give my views regarding guarantees on gold filled cases. I think it quite a serious question. I feel that I must make the guarantees of cases which I sold good, regardless of what the factories do in that direction.

No. 1. I have no objection to, same is very good.

No. 2. Is fair and all that could be asked for; the one objection is that so many cases wear only from three to six years.

Nos. 3 and 4 I cannot approve of—they are unfair. Respectfully,  
HENRY BIRKENBUSCH.

WASHINGTON, Ia., Sept. 11, 1899.

Editor of THE JEWELERS' CIRCULAR:

In answer to your circular letter of questions will say:

That the manufacturers of filled cases should give a new case if one does not wear the length of time they claim for it, because the purchaser buys the case with the understanding that it will wear, say, 20 years, and if it should only wear 10 years it would not be just to the purchaser to replace it with a 10 year case; the 20 year case was not a 20 year case, it was only a 10 year case and should not have been put on the market for over a 10 year case. Then there would be no trouble in making the case good as it has not worn as long as they claimed it would wear. If the case does not wear 20 years the buyer is deceived; he does not get what he thought he was buying. A reliable case maker will not hesitate to replace one of his cases if it does not wear the length of time claimed for it with careful wear.

Yours respectfully, L. D. ROBINSON.

YOUNGSTOWN, O., Sept. 11, 1899.

Editor of THE JEWELERS' CIRCULAR:

Yours in regard to case guarantees at hand.

I have always handled good makes of cases and have had very little trouble. However, when a case does fail the customer is always dissatisfied, and to be provided with a case to fill out the unexpired time would not be altogether satisfactory to him. He feels that he has not had what he bought, and, as a rule, he will not be thoroughly pleased with less than a case such as he at first bargained for. He, of course, gets more than he paid for, and really more than he is fairly entitled to, but as good cases rarely give out before their time, I think it is to the interest of the retailer and the maker both to give the customer a new case, provided he will be

pleased with nothing less. I, of course, am rather inclined to think that I would not feel like giving a new 20-year case in place of one that had worn all right for a period of 15 or 16 years. In short, I have found it best to satisfy people who have had goods that failed to give satisfaction, provided they did not show that they intended to impose upon me. Unless the demand is out of all reason it is policy to keep the fellow with the money in good humor.

Yours, etc.,  
F. M. POWERS.

JACKSON, O., Sept. 11, 1899.

Editor of THE JEWELERS' CIRCULAR:

In reply to yours of the 8th inst. in regard to filled cases will say:

1. The manufacturer should give a new case in exchange for the one not giving satisfaction, because he put a guarantee in the case that it will wear that long and advertised it so to the public at large, and on the strength of that the jewelers make that promise to the customer, which the case company should make good.

2. It should be exchanged for a case of the same grade, as that is what the customer bought, if any exchange is made.

3. Where it can be done, we think it just to the customer to put case in condition to wear the unexpired term.

4. It would be bad policy to ask the customers to buy a new case and rebate for the unexpired term of guarantee.

A word about filled cases. We think it is wrong to put a time guarantee on such cases, because all people do not wear a case the same way; in other words, a railroad man or a brick mason will wear the gold through in some places on the best filled case made in a few years, and a professional man or a clerk, with smooth hands and clean pocket, can wear it four or five times as long and not show as much wear. There are also a great many filled cases where the engraving is cut through the gold, and also in polishing them the gold is left very thin in some places. We don't think there is a filled case made that will not show the base metal in some place before the time of guarantee has expired, no matter how careful the customer is.

Why don't the case people say in their guarantee that the *exposed to wear edges* of the case will not stand the wear that the body of the case will, and the guarantee does not mean that a case will not show any part worn through in 20 years from the day it is bought and all at once it will all wear off. If the case companies were called on to replace all cases that are worn through to the base metal before the time of guarantee has expired it would take every case they had on hand. It is often impossible for jewelers to get a customer to pay the express charges on an exchanged case.

Yours,  
H. A. BEDEL & Co.

STERLING, Ill., Sept. 11, 1899.

Editor of THE JEWELERS' CIRCULAR:

In reply to yours of Sept. 8 regarding the guaranteeing gold filled cases, in my opinion either No. 1 or 2 would be just. In reply to No. 3 I cannot see how the manufacturer can repair a filled case so it will survive the life of the guarantee.

No. 4. The purchaser had paid for his case, with positive guarantee, and will not pay the second time for it without causing the retailer trouble, and that is what we do not want, as it places us in a bad light to our customers. If the manufacturer cannot afford to replace cases which have not worn as per guarantee, let him add more gold and charge in proportion to the amount of gold added, and go back to the



STERLING SILVER....

**CHATELAINE BAG**

....in....

ANTIQUE FLEMISH FINISH.

Price, Seal or Velvet,

**\$17.50 NET.**

SPECIAL VALUE....

AND VERY CHOICE.



No. 2085,  $\frac{2}{3}$  scale.

**DEITSCH BROS.,**

14 EAST 17TH ST.,

NEW YORK.



old plan, 20-year guarantee, and not keep cutting off the amount of gold and extending the years of guarantee.

I am truly,

E. W. BLOSSOM.

INDIANAPOLIS, Ind., Sept. 11, 1899.

Editor of THE JEWELERS' CIRCULAR:

In answer to yours of Sept. 8, '99, would say I think No. 1 is the proper thing for factories to do. Then there is no trouble with the customer and everyone is well pleased. It shows your customer you are willing to do just what you represented to him you would do. It also shows the dealer the factory is protecting him. Therefore the manufacturer should give a new case of the same guarantee in exchange for the old case that has not lived up to its guarantee. I remain yours respectfully,

LON R. MAUZY.

GOSHEN, Ind., Sept. 11, 1899.

Editor of THE JEWELERS' CIRCULAR:

I think your first suggestion is the best for the retail jewelers, for if we get an even exchange there is no kick coming from the customer, and we will sell more goods of the same make, for the people will not be afraid to take hold of them. I think the manufacturer ought to give one of the same guarantee cases for one that has not held up to what it was guaranteed for.

Yours,

C. G. ADAMS & SONS.

SPRINGFIELD, O., Sept. 11, 1899.

Editor of THE JEWELERS' CIRCULAR:

Your letter referring to guarantee of gold filled watch cases duly received. We would suggest your guarantee No. 1, as the retailers would have more annoyance than the watch sale would be worth if we wanted to duplicate something less than what was sold in the beginning. The very few cases that are returned for exchange the manufacturers can easily duplicate, and they can live up to their agreement, providing they make legitimate goods. We handle nothing but standard makes and have but very little trouble.

Yours truly,

MARGILETH & McFARLAND.

(Series of letters to be continued.)

**The Industrial Commission.**

**Investigation Before the Commission of the Workings of the International Silver Co.**

WASHINGTON, D. C., Nov. 15.—The Industrial Commission is still holding its investigations in this city, and among the latest industries to come up for examination is the silver ware, not only in its trust form, but in that of individual firms. The former interest was represented by the president of the International Silver Co., Samuel Dodd, of Meriden, Conn., and also by one of the directors, W. H. Watrous, of Hartford. N. Burton Rogers, representing C. Rogers & Bros., Meriden and Danbury, Conn., was the only representative of individual interests interviewed to-day.

The organization of the International Silver Co. last year was effected by the combination of 15 different firms, the capitalization of the company being \$20,000,000; out of \$11,000,000 of preferred stock \$5,100,000 worth has been issued; the common stock is placed at \$9,000,000. This company control from 55 to 60 per cent of the output of plated ware, and about 10 per cent of that of sterling silver goods manufactured in the United States. While these facts were acknowledged to-day by Mr. Dodd, yet he claims the combination is almost in the nature of a family affair between the old established firms of Connecticut, and was not effected to lessen the competition in this trade, but rather to lessen expenses and to enable all parties concerned to manufacture more economically; and the claim is made that, prior to the organization of the combine, many of the manufacturers were selling at a loss.

It is claimed by the combine that it has not reduced the number of traveling salesmen employed, and that more employes are now on the rolls. While it was admitted that two manufacturing plants had been closed since the formation of the company, it was claimed that this was done because there was waste room in other plants that could be utilized for the same purposes, and thus aid to lessen the

expenses of the corporation. It was also admitted that it is the intention of the company to close at least 10 of the 15 stores in operation in various cities.

The value of trade-marks owned by the corporation was placed at about \$10,000,000. The other \$10,000,000 of the capitalization is represented by the various plants themselves and stock on hand. During the past year prices have been advanced; but, it is claimed, that this has been rendered necessary by the advances that have been made in the cost of raw materials; and, as an offset to this, it is claimed that wages have been advanced from five to seven and one-half per cent above what was paid by the individual firms in the combination prior to the formation of that combination.

From the evidence of Mr. Rogers it appears that he is to-day opposed to the combination, although his firm had practically agreed to become members of the organization as first planned, and at that time an option was given on the plant; indeed, so far had the matter progressed that the books of the company were opened to the examination of the promoters. Negotiations were not completed at that time, and later, when the combination was completed, his firm were not asked to enter the combine.

He expressed himself as of the opinion that the present combination was run for the benefit of the promoters; as evidence of this the statement was made that, at a recent meeting of the board of directors the salaries of the officials were increased as follows: President's from \$7,000 to \$12,000 per annum; treasurer's from \$5,000 to \$25,000, and director's from \$5,000 to \$10,000 per annum each.

Mr. Rogers gave it as his opinion that a combination run on strictly business principles would be of advantage to the trade.

MERIDEN, Conn., Nov. 17.—President Dodd, referring to Mr. Rogers's statements as to the increases in the salaries of the officials of the International Silver Co., said: "There is not a word of truth in them."

**THE APOLLO** 

WARRANTS THE EPITHET "POPULAR,"

as shown by sales from Maine to Oregon.

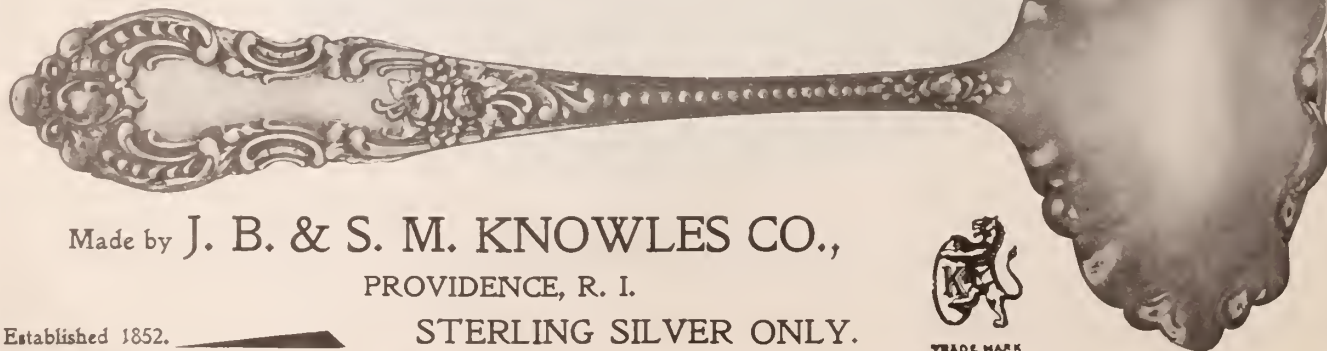

Made by **J. B. & S. M. KNOWLES CO.,**

PROVIDENCE, R. I.

Established 1852.

**STERLING SILVER ONLY.**



TRADE MARK

*"Sterling Silver Goods Only."*

This is only one of our new  
**BONBON DISHES**

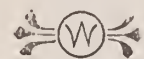

TRADE-MARK.

**FRANK M. WHITING  
& CO.,**

**Silversmiths,**

**NORTH ATTLEBORO, MASS.**

1128 Broadway, New York.  
220 Sutter St., San Francisco.

Complete line of Samples always on display  
at our New York Office.

Our line of Dishes, Trays, Bowls,  
Tea Sets, Loving Cups, Toilet  
Goods, etc., is very complete  
this season.



Bonbon Dish,  
No. 2142.

# "OMEGA" WATCHES.

**NONE BETTER MADE. OVER 1,000,000 IN USE.**

We want ALL LEADING Jewelers to  
know that the "OMEGAS" are the best  
watches for you to handle.

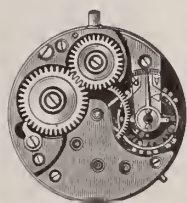

FINE ANCHOR MOVEMENT, 10 LIGNE,  
FULL JEWELLED—FITTED IN 14 AND 18K.  
O. F. CASES, SMOOTH AND FANCY  
ENAMELED CASES. GOOD SELLERS  
FOR FINE TRADE.

SEND FOR PRICE-LIST.



Pendant Set. 12, 14 and 16 Size.  
Made in Gun Metal, Silver, Gold Filled  
and Solid Gold Cases.

BECAUSE—They are ACCURATE timepieces.  
BECAUSE—They are SOLD only to the TRADE.  
BECAUSE—They give SATISFACTION to your CUSTOMERS.  
BECAUSE—They are PROFITABLE, as no prices are adver-  
tised in any journal.

The "OMEGAS" are  
Pendant Set, fit 0,  
12 and 16 size Wal-  
tham cases, and  
are made in 6 dif-  
ferent grades, as  
follows:

7 Jewels, Expansion  
Balance, Double Roller,  
Nickelized.

15 Jewels, Expansion  
Balance, Double Roller,  
Nickelized.

15 Jewels, Expansion  
Balance, Double Roller,  
Nickel, Pat. Reg.

17 Jewels, Expansion  
Balance, Double Roller,  
Nickel, Pat. Reg., ad-  
justed.

17 Jewels, Expansion  
Balance, Double Roller,  
Nickel, adjusted to 5  
positions.

21 Jewels, Expansion  
Balance, Double Roller,  
Nickel, adjusted to 5  
positions.



Pendant Set. 0 Size.  
WITH SECOND HAND.

Warranted Fine Timepieces.  
ALL PARTS INTERCHANGEABLE

Above made to order with  
dealer's name if desired.

**E. E. ROBERT, 3 Maiden Lane, New York; CROSS & BEGUELIN, 17 Maiden Lane, New York, Selling Agents.**

### Duty on Drilled Pearls.

#### Geo. F. Kunz Testifies as to the Nature and Commercial Status of Drilled Pearls.

Testimony to be introduced in the suit in the United States Circuit Court by Tiffany & Co. against the United States, and relating to the question as to the tariff on drilled pearls, was taken Wednesday before a referee in the Post Office building, New York. The question at issue is in brief as follows:

The present tariff law provides a 10 per cent duty for "pearls in their natural state," while strung pearls are assessed at 60 per cent. Tiffany & Co. imported pearls drilled but not strung, and the Board of United States General Appraisers decided, in an opinion published in THE CIRCULAR at the time, that the pearls in question were not in their natural state, and therefore not dutiable at 10 per cent, and by this decision were assessed at 20 per cent as "non-enumerated manufactured articles."

From this decision Tiffany & Co. took an appeal to the United States Circuit Court, and this appeal is now pending. The testimony Wednesday was taken before General Appraiser Wilkinson, who acted as referee, and was on behalf of the importers. Geo. F. Kunz, the gem expert of Tiffany & Co., was the witness examined, and his testimony was both specific and comprehensive. After giving his experience and showing that he was qualified to speak as an expert, Mr. Kunz

went on to say that pearls, as purchased in the open market, might be either drilled or undrilled, and that in many parts of the world the natives who gathered pearls fastened them to pieces of silk or other substance for the purpose of carrying them about. The fastening is sometimes done by a hole through the middle of the pearl and sometimes by a hole at each end. Pearls, he testified, are purchased by dealers according to their weight and quality, and the question of being drilled or undrilled was not a matter of importance, except that the dealer usually preferred to purchase the pearl undrilled and to do the drilling himself. Drilling, if anything, rather decreases than increases the value of the pearl. The goods imported by Tiffany & Co., he testified, were not, as had been contended, brooches, necklaces, bracelets, etc., of pearls that had been simply broken up, but were purchased as pearls.

The general trend of his testimony was to the effect that in commercial language a pearl was considered in its natural state, whether drilled or undrilled, and that drilled and undrilled pearls were sold side by side in the market as the same articles.

#### Death of William H. Morris.

William H. Morris, one of the oldest and best known jewelry travelers to the western trade, died suddenly at the Brevoort House, Chicago, at 2 o'clock A. M., Nov. 15. Mr. Morris was the western traveler for J. W. Richardson & Co., man-

ufacturers of emblems, 1 Maiden Lane, New York, and was at the time on a business trip for them. He arrived at Chicago several days ago, and was apparently in good health. Last Tuesday night he was seized with severe pains in the region of the heart, which became so acute that a physician was hastily summoned by the hotel clerk. Mr. Morris then grew rapidly worse and died shortly after midnight.

The deceased was born in Newburg, N. Y., about 45 years ago, and when about 17 years old entered the employ of J. W. Richardson & Co., as a boy. He gradually rose until at the death of one of the partners he succeeded him on the road and became western traveler for the firm, a position he occupied from that time until his death. During his employment with this firm Mr. Morris became closely acquainted with all the principal jewelers in his territory, and among them made many strong and lasting friends. Mr. Morris was married and lived with his family at 40 Stuyvesant Place, St. George, Staten Island. His widow and four children survive him. He was one of the earlier members of the Jewelers' League, was a member of the Brotherhood of Traveling Jewelers and also belonged to the Knights of Columbus.

The remains were brought on from Chicago and arrived in New York Friday. The funeral services were held Saturday at 10 o'clock A. M. at St. Peter's Church, New Brighton, Staten Island. The remains were interred at Calvary Cemetery.



Prices on  
Application.

**The Mauser Manufacturing Co.,**

...SILVERSMITHS...

15th Street, between Broadway and 5th Avenue, NEW YORK.

# A. WITTNAUER,

MANUFACTURER OF

## THE CELEBRATED

# Longines and Agassiz Watches,



9-11-13  
MAIDEN LANE,  
NEW YORK.



AGASSIZ MOVEMENT  
1899 MODEL.

WHICH HAVE BEEN  
SOLD TO THE LEAD-  
ING JEWELERS OF  
THE WORLD DUR-  
ING THE PAST

## 53 YEARS.

WE HAVE A COMPLETE VARIETY OF

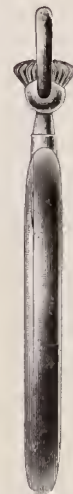

CASE  
1899 MODEL.

## Decorated Watches for the Holiday Trade.

9-11-13 Maiden Lane,         New York.

Geneva Office, 16 Rue du Mont Blanc.

**Important Bankruptcy Decision**

**Judge Brown Decides Against the Buying Off the Opposition to Procure a Discharge in Bankruptcy.**

An interesting decision in bankruptcy law, having an important bearing on the subject of buying off the opposition of creditors to procure a discharge in bankruptcy was handed down last week by Judge Addison Brown, of the United States District Court, in New York. The opinion was written on the application of H. A. Groen & Bro., to vacate the discharge of Herman J. Dietz, and is the first one in this district granting such an application. Dietz was formerly a dealer in diamonds, and his sensational failure a few years ago, when he was in business at 65 Nassau St., will be remembered by the trade. Judge Brown's opinion, which explains in full the nature of the points under consideration, is as follows:

*Brown, J.* This is an application to vacate the discharge of the bankrupt granted on July 19, 1899, on the ground that it was corruptly procured by the payment of \$200 to an opposing creditor as a consideration for withdrawing his objections to the discharge.

The adjudication was made on the bankrupt's voluntary petition on February 25, 1899. Seven creditors proved claims. Among them was the petitioner for the amount of \$4,029.91 and a claim of Feigenbaum & Schweiger for \$1,690.37. Max Schweiger, a partner in the last named firm, was chosen trustee by the creditors, the present petitioners voting for him. Upon the bankrupt's application for a discharge in April, specifications in opposition to the discharge were filed by Feigenbaum & Schweiger only, although the attorneys employed by Groen & Brotber, petitioners, were instructed to co-operate with the attorneys

of Feigenbaum & Schweiger in opposing the discharge. Considerable testimony was taken before the referee to whom the specifications were referred. On the 7th of July a written withdrawal of the specifications was filed with the referee, and thereupon upon the report of the referee a discharge was granted on July 19.

The various affidavits submitted upon the present petition show that Feigenbaum & Schweiger received \$200, being about 10 per cent of their claim, and two other creditors a like percentage, one from one, Blumberg, a cousin of the bankrupt's wife, for an assignment of their respective claims to him and the withdrawal of the objections to the discharge. The money was first lodged with a depository, under an agreement made by the attorneys of Feigenbaum & Schweiger, who thereupon withdrew the objections, suffered the discharge to be granted unopposed, on the motion of the bankrupt's attorney and thereafter received the money as agreed from the depository.

There is no doubt as to the payment of the money. That appears from the affidavit of Mr. Schweiger himself. But it is contended that the bankrupt neither procured this payment nor had any knowledge of it, and was not in any way privy to it. The bankrupt makes oath to this effect, as thoroughly and as variously as possible. Mr. Schweiger indeed makes affidavit to certain circumstances leading to the contrary inference, as that during the negotiations the bankrupt was seen by him in the elevator coming down from the office of his attorneys, though this is denied by the bankrupt. The whole amount paid by Mr. Blumberg for the assignment of these claims was \$500. He had acted previously to some extent as a banker for the bankrupt, and he states that the payment of this money was purely voluntary and as a gift, and as a consequence of his interest in the bankrupt, and his wish to make some use of him, and to rid himself of the annoyance of further examination in the bankruptcy proceeding.

There is no doubt that if the opposition of the creditor is bought off through the procurement or privy of the bankrupt, it is such fraud upon the Act as would warrant vacating the discharge, the fact itself being prima facie evidence that the bankrupt was not entitled to it. *Tuzhury vs. Miller*, 19 John, 311; in *re Douglas*, 11 Fed. 403, 406; in

*re Palmer*, 14 N. B. R. 437; *Blasdel vs. Fowle*, 120 Mass. 447; *Bell vs. Leggett*, 7 N. Y. 176. The general subject was very fully considered in the case last cited, and it was declared to be

"Of no consequence that the arrangement was made between the creditors of the bankrupt and a third person without the intervention or knowledge of the bankrupt."

All such arrangements are to be condemned, as at variance with the policy of the Bankruptcy Acts, whether expressly prohibited by the Statute or not (*Smith vs. Bromley*, Doug. Rep. 693), and as injurious to all creditors, because calculated

"To suppress the inquiry and to protect fraud and concealment from successful disclosure and development, \* \* \* and to give the bankrupt a benefit designed for the honest insolvent, and which the fraudulent debtor by sound justice and express provisions of the Statute was prohibited from receiving."

In the case of *Ex parte Briggs* (2 Lowell, 389), where a surety of the bankrupt upon an attachment bond paid the debt to a creditor who was opposing the bankrupt's discharge in his own account and wholly without the bankrupt's knowledge or privy, it was held that the discharge was not vitiated. Judge Lowell, however, expressly avers that that was an exceptional case; and he adds:

"I do not intend to say that payment by a friend actually made in behalf of the debtor with his knowledge is not prohibited, nor that very slight evidence would not affect him with participation."

It is not necessary for me to make any ruling in this case on the effect of a withdrawal of opposition procured without any actual or constructive knowledge or participation by the bankrupt. I am not satisfied that such was the present case. Though the verbal protestations are very strong to this effect, the circumstances all point to a contrary conclusion. Not indeed that the bankrupt personally was an active participant, for no doubt he was not; but his prior personal relations to Blumberg, as well as through his wife, the improbability that this sum of \$500 would have been advanced by him in the manner stated without the bankrupt's indirect privy, the fact that the money was lodged with a depository, to be turned over only after the discharge was granted, and the course of practice necessary to procure such a withdrawal and a discharge of the bankrupt through the bankrupt's attorney upon such a withdrawal, show that the transfer of these claims to Blumberg had nothing of the character of a mere purchase of them for what they might be worth, but was a very carefully planned and systematic means for procuring the withdrawal of the opposition, and thereupon the bankrupt's discharge; and such a procedure could not well take place without the privy, concurrence and knowledge of the bankrupt's attorney, as to which nothing appears in the opposing affidavits.

Another circumstance also makes it peculiarly proper that this case should be re-opened, namely: that in the conduct of the proceedings, the specifications in opposition to the discharge filed by Feigenbaum & Schweiger were relied upon by the petitioners as representing their own objections and under which their attorneys were acting conjointly. They had no notice of the application for discharge and were not heard. Strictly they were not entitled to notice of hearing, since they had not interposed independent objections; but the relations of Mr. Schweiger as trustee for all, and the knowledge of all parties of their reliance upon the specifications and participation in the opposition, as shown by the record, requires in good faith that the proceedings should be reinstated to the situation immediately prior to the withdrawal.

The order of discharge should be vacated, and the matter remitted to the referee for further bearing in behalf of the petitioners upon the specifications previously filed, which may be adopted by them.

Nov. 16, 1899.

**Death of George H. Smith.**

LANCASTER, O., Nov. 14.—George H. Smith, jeweler, of this city, died suddenly at his home this morning. He had been in failing health for a year or more. He had been a resident here for about 40 years. He leaves a widow, who is a sister of Judge Joseph Olds, of Columbus, and five children, Harry, Edson, Joseph, Rose and Lucy, all at home. Funeral will take place Thursday morning from St. Mary's Catholic Church.

WATCHES

WATCHES

WHO SAID WATCHES?

Ladies' Watches,  
Gentlemen's Watches,

Railroad Watches.

We Are the Largest Distributors of

Dueber-Hampden Watches

IN NEW YORK.



John A. Pierwood & Co.

Watches. Chains. Diamonds. Jewelry.

No. 3 MAIDEN LANE, NEW YORK.

# THE DUEBER HERALD

THE ADVOCATE OF HONEST BUSINESS METHODS.  
\* DEVOTED TO THE RETAIL JEWELRY TRADE. \*

Vol. I.

CANTON, OHIO, NOVEMBER, 1899.

No. 8.

## SIMPLE ARITHMETIC.

Put one and one together.

\* \* \*

Take Honesty of Purpose; add honest, thorough-going Ability.

\* \* \*

Subtract "Rainbow Chasing;" multiply by Success, and the result is: The Perfect Product.

\* \* \*

The Dueber-Hampden watch represents honesty of purpose, honest, thorough-going ability, religious avoidance of "rainbow chasing"; it represents: Success!

\* \* \*

Therefore, the Dueber-Hampden watch is the perfect product, the perfect watch, "The Best." Its every tick, as Time wears on, marks more and more the triumph of Honesty, Ability and Truth.

Palestine, Texas.

I am proud to be the possessor of a Dueber-Hampden watch in a gold Dueber case. In my estimation, a railroad man who is subjected to such continual jostling and changes of temperature and atmosphere, there is no watch which can beat it. I have been 14,000 feet above sea level in Colorado, 260 feet below sea level in the desert of California, under the tropical sun of Mexico, and my Dueber-Hampden never failed me.

GEO. H. WESTERVELT.

## THE QUESTION OF POLICY.

Sweet smiles and honeyed words play their part in business, as they do in the rest of the world's affairs.

*The Dueber Herald* does not admire sweet smiles and honeyed words. *The Herald* believes in a "straight-out-from-the-shoulder" policy.

The merchant who makes Reliability his watchword, who studies the why and wherefore of the goods he sells that he may be sure of his ground, needs no unctuous demeanor, no bowing and scraping to make and hold trade.

The dealer who is sure of his ground, who sells an article that he can stand by—and knows it—may safely cultivate a reasonably independent attitude. Then his words will carry a conviction that the hon-eyed kind do not.

Let those who differ, try.

Dueber goods sell on their merit. Study the question and you will be sure of your ground.



Entrance to Office, Hampden Watch Works.

## AGAIN THE STAMP.

Honest money ought to buy honest goods.

\* \* \*

Honest goods ought to be honestly stamped.

\* \* \*

A misleading, dishonest stamp on a watch case, is like a misleading, dishonest stamp on a piece of silver.

\* \* \*

Is it, therefore, not of vital importance to you and to every honest jeweler in the country that dishonestly stamped watch cases be driven out of the market?

\* \* \*

Answer the question to yourself; then act.

\* \* \*

## DUEBER WATCH CASES

ARE

First in Weight,  
First in Style,  
And first in the hearts of those who know.



# A. & B.

## HEADQUARTERS

FOR

## Waltham Watches

EVERY GRADE.

## AVERY & BROWN,

68 Nassau St., New York.

**CASH OFFERS.**

If at any time you have offered to you by your customers any Jewelry containing diamonds, pearls or other precious stones and you do not care to buy them yourself, send them to us and we will submit an IMMEDIATE CASH OFFER. Trade and Bank References if desired. Established 1880. Correspondence solicited.

CHARLES S. CROSSMAN & CO.,  
3 Maiden Lane, New York.

**Importations at the Port of New York.**

*Week ended Nov. 18, 1898, and Nov. 17, 1899.*

China, Glass and Earthen Ware:	1898.	1899.
China .....	\$93,680	\$83,132
Earthen ware.....	21,603	15,211
Glass ware.....	35,561	26,601
Optical glass .....	not recorded	3,773
Instruments:		
Musical .....	17,830	20,470
Optical .....	3,772	6,954
Philosophical .....	2,959	4,327
Jewelry, etc.:		
Jewelry .....	7,627	7,943
Precious stones .....	181,660	202,463
Watches .....	15,662	26,121
Metals, etc.:		
Bronzes.....	2,874	.....
Cutlery .....	13,034	38,736
Dutch metal .....	.....	3,510
Platina .....	11,978	35,162
Plated ware .....	1,522	545
Silver ware .....	24	8,715
Miscellaneous:		
Alabaster ornaments.....	1	643
Amber .....	934	.....
Beads .....	2,123	2,653
Clocks .....	4,985	4,745
Fans .....	6,313	4,250
Fancy goods .....	5,774	9,532
Ivory .....	9,051	3,220
Ivory, manufactures of.....	16	810
Marble, manufactures of....	12,925	17,851
Statuary .....	1,913	2,464

**The Career of the Late August Claus.**

SPRINGFIELD, Ill., Nov. 15.—The funeral services of August Claus [notice of whose death was published in THE CIRCULAR of Nov. 15] were held at the family residence Sunday afternoon.

Mr. Claus was born in Germany, in June, 1845. When a young man he came to America, and shortly after located in Springfield. He began life as a jeweler, having learned the trade in the old country. Before long he started in business for himself, and while he became successful his success was well earned and was not without attendant griefs. Mr. Claus suffered more than his share of sorrow in the death of his wife and three children. His daughter, Lottie, was the first to pass away. She died in the month of November, 1896. Five months later his wife died, and three months after her death occurred the death of his son, William Claus. About a year ago another son, Henry Claus, died in Denver, Col., and was buried in this city. Five children are still living. They are: Mrs. Lena Blakesley, wife of William Blakesley, recently married; Miss Emma Claus and Edward Claus, residing in this city, and Andrew and August Claus, Jr., who are engaged in the jewelry business at Denver, Col.

Mr. Claus was well known in fraternal and benevolent circles. He was prominent in Masonry and was a Knight Templar. He was also an old member of the I. O. O. F. and of the Knights of Pythias and was one of the charter members of the Germania Maennerchor. The members of these organizations unite in declaring that in his life were embodied the best principles of their orders.

**CROWN 14 K  
FILLED CASES**



**GUARANTEED  
FOR  
25 YEARS**

There is  
**No Difficulty**  
in selling

**Crown 14 K. and Lion 10 K.  
Gold-Filled Cases.**

They are built on honor, and guarantee is limited only by the period of time. They are made up in the newest patterns and shapes. They have earned the confidence of the buying public by their many years of proved worth. They are sold as low as any cases of equal quality.

**Crown and Lion Gold-Filled  
Cases are  
Sold by All Jobbers.**

**LION 10 K  
FILLED CASES**



**GUARANTEED  
FOR  
20 YEARS**



**ALMOND-DISHES  
SOMETHING FOR YOUR  
HOLIDAY TRADE**

THESE DISHES ARE OF GOOD  
WEIGHT AND THE PRICES  
AT WHICH WE ARE SELLING  
THEM PERMIT OF THEIR  
BEING USED AS LEADERS  
BON · BON · DISH  
TO MATCH ··· WRITE

FOR PRICES  
ILLUSTRATIONS  
FULL SIZE



NO. 257.



NO. 258.



NO. 1000.

**R. WALLACE**

**& SONS MFG. CO.**

**SILVERSMITHS**

**WALLINGFORD · CT.**

**BRANCHES**

**226 · 5<sup>TH</sup> · AVE · NEW · YORK**

**109 · WABASH · AVE · CHICAGO**

**120 · SUTTER · ST · SAN · FRANCISCO**

# Simplicity of Construction

combined with superior work-  
manship, is what makes the

## Trenton Watches

the most reliable of all low-  
priced movements.



12-Size Trenton, 7 Jewels, Stem-  
Winding, Lever-Setting, Hunting,  
(open face) without second hand.  
Supplied in Silver and 5-year Gold-  
Filled Cases.

The "Trenton," for the price,  
far surpasses any movement  
ever placed upon the market.

SEND FOR PRICE-LIST.

The Trenton Watch Co.,  
Trenton, N. J.

### Young Men, Don't Be Half Jewelers.

What about your future? Is it as bright  
under your present circumstances as it would  
be were you equipped with the best knowledge  
of your profession? Why not resolve to come  
to us? Why not let us make a gilt-edge work-  
man of you? Why not let us start you on the  
road that leads to double salary and importance?

We teach thoroughly  
Watchmaking, Engraving,  
Jewelry Work and Optics.

Write for our Prospectus to-day.

F. W. SCHULER, Principal,  
1215 Filbert Street, Philadelphia, Pa.

### Joseph H. Sandman Perpetually Enjoined from Using Word "Waltham."

Judge Townsend, of the United States Circuit Court, in New York, Monday filed the final decree in the action brought by the American Waltham Watch Co. against Jos. H. Sandman, granting to the American Waltham Watch Co. the injunction asked for in the complaint. This action, it will be remembered by the readers of THE CIRCULAR, was tried nearly a year ago and was brought by the plaintiffs to restrain Sandman from selling watches marked "Waltham" that were not made by the plaintiff company. Sandman was the selling agent of E. A. Locke who manufactured watches at Waltham under the style of the Columbia Watch Co.

Judge Townsend's decree, filed Monday, grants to the American Waltham Watch Co. a perpetual injunction restraining Sandman, his agents or attorneys, etc., first, from selling, offering, advertising, or otherwise disposing of watches, watch movements or parts thereof marked or inscribed with the word "Waltham," unless accompanied by the words "Massachusetts" or "Mass.," and unless there is also prominently collocated with the word "Waltham" when so used, in letters easily legible, the words "A new watch company at Waltham, established 1894;" second, from using the word "Waltham" in any advertisement of watches, not made by the complainants, otherwise than geographically in connection with "Massachusetts," in giving the place of business of the maker of such watches, and the defendant is required in all advertisements to take precautions to distinguish the maker of such watches from the American Waltham Watch Co., to the full extent of commercial practicability; third, from selling, offering or advertising watches, not made by the complainants, bearing the words "Waltham" or "Waltham, Mass.," and bearing

numbers not subsequently corresponding to the number of watches made by the manufacturer of the goods so offered; fourth, from using the word "Waltham" on watches, not made by the complainants, in such a way as to induce the belief that they were made by the American Waltham Watch Co., and from doing anything to avail himself of the reputation of the American Waltham Watch Co. The defendant is to pay the costs of the suit, but neither profits nor damages are assessed. The decree is final.

### Decision in Koenen Offset Guard Eye- glass Case Suit.

The suit brought by John G. Koenen, 81 Nassau St., New York, in the United States Circuit Court, at Boston, Mass., against the Orient Mfg. Co. and Wilton E. Drake, of that city, was tried there last week and a decision in favor of the defendants was rendered by Judge Lowell. This action, as already told in THE CIRCULAR, was brought to restrain the defendants from manufacturing or selling an alleged infringement of a design patent on eyeglass cases with raised space for offset guards, granted to Koenen, Oct. 18, 1898, and the suit excited considerable interest in the optical trade. Judge Lowell's opinion is as follows:

"The prior state of the art, as shown in some of the numerous objects produced at the hearing, makes it clear that the complainant's patent, if it has any validity, must be limited to a construction in every detail like that set out in the specifications and exhibited in the drawings. The defendants' eyeglass case, while it doubtless resembles the complainant's in a general way, differs from it in several of these details. Indeed, its design appears to me so different that I doubt if anyone would confound the two. Upon the whole, the complainant's design seems unpatentable, but, if patentable, then it has not been infringed. Decree for the defendants."

H. A. West, solicitor for Mr. Koenen, stated Monday that an appeal would probably be taken from this decision.



# WHY WAIT?



The holiday trade promises to be the  
largest in the history of the country.  
We are far behind our orders, and any goods  
you may want for

## CHRISTMAS, ORDER NOW.

Our new illustrated catalogue sent on application.

### S. STERNAU & CO.,

Manufacturers of Metal Wares in Brass, Copper and Silver,  
204 Church Street, New York City.

# Enameled Watches

Iridescent and dull finish

New England Watch Co.  
Waterbury,  
Conn.



## “Elf”

—10 Ligne.

ALL ENAMEL,  
IRIDESCENT:

Blue,	No. 8803
Red,	8805
Green,	8807

INLAID ENAMEL BACK,  
IRIDESCENT:

Blue,	No. 8483
Red,	8485
Green,	8487

DULL ENAMEL:

Chrysanthemum Pattern.

White,	No. 8661
L't Blue,	8663
Green,	8665

Rococo Pattern.

White,	No. 8621
L't Blue,	8623
Green,	8625

## “Cavour”

—15 Ligne.

INLAID ENAMEL BACK:

Blue,	No. 9653
Red,	9663
Green,	9667

The numbers above given call for blue watches—the price list will show the numbers of other colors.

## CHARMING - STUNNING - BEAUTIFUL:

the gleam of the iridescence and the dainty gold florets underlying the enamel produce an effect that is simply exquisite. Our *Enameled Watches* are in all the best colors to match, or harmonize with, the most delicate shades of dress goods. The *Iridescent Enamels* are in dark red, blue, and green (with like colored dials, if desired), and the *Dull Enamels* in light blue, light green, and white, with rich cream dials, figures of either gold or blue, and delicately patterned gold hands.

The enameling is all on Sterling Silver, which gives precisely the same effect as if it were on solid gold, and at a great saving in cost.

*Brooches* may be had to match the watches in designs and colors; attractive boxes add to their effectiveness as holiday packages.

Our last year's enamels were the first to be sold out, and although we have a splendid stock of these new styles for this season, we do not expect the line to last very long.

Decide upon what you want, then *order at once* and *save disappointment*.

**THE NEW ENGLAND WATCH COMPANY,**  
WATERBURY, CONN.

**The Sigler Diamond Robbery.**

Revised Value of Goods Stolen \$18,000; List of the Diamonds Stolen.

CLEVELAND, O., Nov. 18.—A revised estimate of the value of the diamonds stolen from Sigler Bros. Co., last Monday afternoon, shows that they were worth about \$18,000. The box stolen contained some 15 papers of loose diamonds, described as follows:

	Weighing
1 fine crystal white diamond,	2 $\frac{1}{4}$ & 3-64k
1 " " " "	2 $\frac{1}{4}$ less 1-64k
2 " " " diamonds,	3 $\frac{1}{2}$ & 1-64k
*28 " " " "	20 & 1-32k
28 " " " "	13 & 15-16k
19 " " " "	13 & $\frac{3}{4}$ k
25 " " " "	9 & $\frac{1}{4}$ k
6 " " " "	5 & 1-32k
7 " " " "	7 & $\frac{1}{2}$ k
2 blue white diamonds	about 2 $\frac{1}{4}$ k
14 white diamonds weighing	5k
52 " " " "	about 24k
6 " " " "	4 & $\frac{1}{4}$ k
6 " " " "	8 & $\frac{1}{4}$ k
80k of small diamonds, known as Melée	
35k " " " Melée, large size	
32k of small diamonds, known as Melée,	weighing from $\frac{1}{4}$ to $\frac{3}{4}$ k, assorted.
20k of small diamonds, known as Melée,	weighing from $\frac{1}{4}$ to $\frac{3}{4}$ k, off color.

The method of procedure adopted by the thieves was as follows: Three men entered the salesroom together, one remaining near the door to cover the retreat of his partners and guard against capture should the theft be discovered before the plunder could be taken out of the room. A second loitered about the cases, while the third approached L. M. Sigler with a proposition to match a fine stone he had in a stud, saying he wished to make a Christmas present of a pair of diamond earrings to his wife. Mr. Sigler took the supposed customer into the diamond room in the front of the store. Taking a box of diamonds from the safe, he selected one and compared it with the setting in the stud. The man who wanted to match diamonds stood in front of Mr. Sigler and engaged him in conversation. The box of diamonds lay on a case back of the proprietor, and while the latter's attention was engaged, the man who had been loitering about the cases in the storeroom stepped carelessly up to the case, took the box of diamonds, walked down the storeroom to the stairway, and thence descended to the street, followed by the man on guard. The supposed purchaser made an excuse about matching the stone he had and left the room. Mr. Sigler turned to replace the diamond he had been examining in the

\*One of the above 28 stones was mounted in a plain Tiffany ring mounting.

box, and discovered that the box was gone. A customer said a clerk had taken it to the other end of the room. By the time it was ascertained that a theft had been perpetrated, the thieves had made good their escape.

The man who engaged Mr. Sigler's attention was about 40 years old, 5 feet 8 or 9 inches tall, 170 pounds weight, and had a sandy mustache, light brown hair and the first joint of the second or third finger of one hand (Mr. Sigler thinks it was the right) was gone. The man who took the diamonds was about 32 years of age, 5 feet 8 or 10 inches tall, 165 pounds weight, with short, black mustache, black hair, was good looking and wore a dark suit, sack coat and black stiff hat.

Sigler Bros. Co. have placed the matter into the hands of the police, and have offered a reward of \$2,000 for the recovery of the diamonds and the apprehension of the thieves. The police are following the slight clues obtainable and hope to catch the robbers.

**DETROIT POLICE CLAIM TO KNOW THE THIEVES.**

DETROIT, Mich., Nov. 18.—Detroit police claim to have furnished the Cleveland officers with information as to the identity of the thieves who stole the large quantity of diamonds from Sigler Bros. Co. It is claimed that they worked Detroit some time ago, and that their names are famous among police departments. Pictures of the crooks were sent to Cleveland, and one of them was identified by Mr. Sigler as the robber who engaged him in conversation while his pals sneaked the stones. The local police officials refuse to give their names for fear of embarrassing the Cleveland officers.

C. C. Lantz, an inventor, living at the Sturtevant House, 29th St. and Broadway, New York, received word from Sigler Bros. Co., Cleveland, O., that the thief who robbed them of a package of diamonds, Nov. 13, looked very much like a photograph which Mr. Lantz once had taken of himself in disguise. At the request of the jewelry firm, Mr. Lantz forwarded to them this photograph, which will be retouched in places to make it look exactly like the thief, and will then be put into the hands of the police to aid them in running down the robbers.

A. E. Winter, Ellsworth, Wis., is out of business.

The business of the Lincoln Optical Co., Lincoln, Neb., has changed hands, L. W. Bever, who has been conducting it for two years, selling to C. E. Clark, who will continue the business under the old name.

**Death of Samuel Sondheim.**

One of the prominent and most generally well liked members of New York's precious stone trade passed away last week in the death of Samuel Sondheim. Mr. Sondheim was found dead in his apartments at 126 W. 41st St., Thursday morn-



THE LATE SAMUEL SONDHEIM.

ing, and had died some time after Tuesday night from suffocation from escaping gas. From the surrounding circumstances at the time Mr. Sondheim's body was found it is believed that he committed suicide. Apparently all preparations had been made by him, as he left the rent for the room, which he occupied at this address, and money for his laundry, etc., laid out and labeled.

The deceased was 50 years of age, and had passed his entire life from early boyhood in the jewelry trade of New York. He was born in New York, July 30, 1850, and when a lad entered the employ of David Bruhl as an errand boy. His rise in this firm was rapid, and within a few years he became salesman. Later, he went to San Francisco and started the San Francisco branch of the concern. After taking charge of this for some years, he went to Yokohama, Japan, starting a branch of the business there, which he also had charge of until 1887. Mr. Sondheim had been given an interest in the firm of D. & M. Bruhl, and, in 1888, when the firm were succeeded by Bruhl Bros. he, with S. Bass, L. Lilienthal, Paul Bruhl and Henri Bruhl, composing the new firm, continued the business. About five years later Mr. Sondheim's partnership agreement expired by limitation, and he then retired

The  
**Mercantile National Bank**

OF THE CITY OF NEW YORK,  
BROADWAY AND DEY STREET,  
Solicits Accounts from the Jewelry Trade.

from the concern and became a diamond broker. For the five years just preceding his death he had followed this line, and of late had an office at 65 Nassau St. It was universally expressed by those who knew him in the "Lane" and vicinity that no more genial, whole souled and lovable companion could be found than "Sam" Sondheim, as they familiarly called him, and many and deep were the expressions of regret at his untimely end.

Mr. Sondheim was reputed not only for his personal, but for his business qualities as well, and showed his acumen and judgment in the purchasing of stones for his firm to be equally as strong as his executive ability displayed in the management of their branch offices. Of late Mr. Sondheim had been in poor health, and though apparently cheerful in manner was believed by his friends to be somewhat despondent. The deceased was not married and is survived only by his four sisters and his nephews and nieces. For many years he was a prominent member of the Harmonie Club. The remains were interred Friday at Cypress Hills Cemetery, and the services were held at the grave.

**Another Member of the Old Bruhl Firm  
Passes Away.**

Simon Bruhl, who many years ago was a partner in the old firm of David Bruhl, up to 1877, died in Paris on Wednesday last. A cablegram announcing his death was received by S. Bass, 54 Maiden Lane, New York, on Thursday.

The deceased was a brother of the late Moses Bruhl, whose obituary was published in THE CIRCULAR of Nov. 8th, and was the youngest of the four brothers connected with the Bruhl firm. Mr. Bruhl was about 50 years of age, and came to this country as a young man, joining in the business founded by his brother, David Bruhl, in 1848, and in which Samuel and Moses were associated. He remained in this country until 1877, when he was stricken with blindness. He then severed his connection with the firm and went back to Europe, where he lived from that time.

**Decision in Action of Frank W. Smith  
Against Meriden Britannia Co.**

The United States Circuit Court of Appeals, in a decision handed down Saturday, has refused to Frank W. Smith, silversmith, Gardner, Mass., a preliminary injunction pending the adjudication of his action against the Meriden Britannia Co. This suit, as already published in THE CIRCULAR, was brought in the United States Court in Connecticut, over an alleged infringement by the Meriden Britannia Co. of a design patent for silver hollow ware, granted to Smith, Nov. 1, 1898. After bringing this suit, Smith applied for a preliminary injunction and this motion was denied by Judge Townsend, of the United States Circuit Court, in an opinion which was published in full in THE CIRCULAR March 1 of this year. The United States Circuit Court of Appeals, which heard argument on an appeal from this decision two weeks ago, has now affirmed the decision appealed from on the opinion of the court below.

## Exquisite Enamel Watches

FOR THE HOLIDAYS.

THE FINEST ASSORTMENT OF  
DAINTY GOLD AND SILVER EN-  
AMELED WATCHES, ARTISTI-  
CALLY DECORATED, FULL JEW-  
ELED LEVER AND CYLINDER  
ESCAPEMENTS.

Quality Warranted.

**HIPP. DIDISHEIM & BRO.,**

54 MAIDEN LANE, NEW YORK.

CHICAGO OFFICE, CHAMPLAIN BLDG.



## Money is in Motion

but it is moving much faster in  
some directions than in others.

The swiftest channel—that  
which is turning goods into money  
quicker than any other line in  
the Jewelry business—is that of

*Diamond Jewelry.*

Our line is right in the middle of the current, and Jewelers  
who bought our goods early in the season are already re-purchasing  
in very large quantities. \* \* \* \* \*

**Kohn & Co.**  
9.11.13 MAIDEN LANE.  
NEW YORK.

**DIAMONDS.**  
**Wm. S. Hedges & Co.,**  
 IMPORTERS OF  
**Diamonds and Precious Stones.**  
**DIAMOND JEWELRY.**  
**170 Broadway, New York.**  
 26 Holborn Viaduct, London.

*Oppenheimer Bros. & Veith,*

*Importers and Cutters of*

*Diamonds*

*Dealers in*

*Watches,*

*Cor. Nassau and John Streets,*  
 (PRESCOTT BUILDING.)

*....New York....*

*Amsterdam,*  
*2 Tulp Straat.*

*London,*  
*45 Holborn Viaduct.*

**MOUNT & WOODHULL,** FORMERLY WITH LATE FIRM OF  
 RANDEL, BAREMORE & BILLINGS,  
 .... IMPORTERS OF ....

**Diamonds, Other Precious Stones, Pearls, Etc.,**  
**Makers of fine DIAMOND JEWELRY,**

26 MAIDEN LANE (SOUTHWEST CORNER), NEW YORK.  
 NASSAU STREET

JOHN C. MOUNT.

ADDISON W. WOODHULL.

RUBIES.

SAPPHIRES.

**C. G. MALLIET & CO.,**

EMERALDS.

14 MAIDEN LANE, N. Y.

DIAMONDS.

## The Bowden Rings

ARE COMPLETE IN VARIETY, CORRECT  
 IN QUALITY AND PERFECT IN FINISH.  
 WE MAKE EVERY VARIETY OF FINGER  
 RINGS

**J. B. BOWDEN & Co.,**

1 MAIDEN LANE,

NEW YORK.

### Precious Stones: London Market

HATTON GARDEN, London, Eng.,  
 Nov. 11, 1899.

It is stated on good authority that no further advance on rough has been made by the Syndicate. It is over three weeks since the last rise was announced, and the interval has not brought very reassuring news as regards Transvaal affairs. It was generally understood in the market (before the outbreak of war) that the Syndicate had decided for the present to put up prices 5 per cent per month, and, accordingly, despite the last irregular rise, it was expected that 5 per cent would be put on last Monday.

The *Daily Telegraph* war correspondent telegraphed under date Nov. 1 as follows: "The DeBeers Mine contemplates closing, but care will be taken to keep the compound natives, 10,000 in number, usefully employed." No further news has been received on the point, but the Boers have blown up 35 tons (valued at £3,500) of dynamite belonging to the company, set fire to a considerable part of the surrounding veldt, and have built forts preparatory to shelling the town. Later news is to the effect that the attacking force has been reinforced by 2,000, is drawing closer in, and has commenced throwing in shells.

The effect of this disquieting news on the Stock Exchange appears to be nil as far as DeBeers shares are concerned, the latest quotation being at the satisfactory figure of 27½. Although troops are now arriving hourly at Cape Town, it must be remembered that it will be some time before any relief can reach Kimberley.

There is nothing fresh to report as regards other gems. R. F.

### Herman Elsholtz Charged with Systematically Robbing His Employer.

PITTSBURGH, Pa., Nov. 18.—On Nov. 15 Herman Elsholtz, of Allegheny, was arrested at his home on Ohio St. He is employed at the store of Joseph Link, 132 Chestnut St., and is charged by Mr. Link with the larceny of watch chains and gold rings. Two of the rings were found in his room. Mr. Link said that he has been missing articles of jewelry for some time, and accuses Elsholtz with taking and disposing of them. Elsholtz has been employed by Mr. Link for six months.

Further developments in this case led to the arrest of Samuel Horowitz, who keeps a jewelry store corner of Penn Ave. and 7th St., on a warrant for receiving stolen goods. This information was made by August Petschat, who is the owner of a gold chain taken from Link's store by Elsholtz. Elsholtz said that he had sold the chain to Horowitz. Horowitz was convicted of a similar offense in 1894 and narrowly escaped punishment on a second similar charge. As this is Horowitz's third offense, it is expected that he will be severely dealt with by the court.

Wm. Louwien will open a jewelry store in Bellville, Tex.

Coville & Moore, Oxford, N. Y., announce that they will close out their entire stock at auction.

**Large Pearl Smuggling Alleged.**

**1,000,000 Imitation Pearls Seized from Francois Bock Upon His Arrival in This Country.**

One of the largest seizures of pearls ever made by Customs officers, on the charge that they had been smuggled, was made Sunday, upon the arrival of the French Line S. S. *La Bretagne*. Among the passengers on this boat was Francois Bock, of Bock Bros., France, who is in business at 104 Burnett St., Providence, R. I. As Bock landed, after making his declaration, he was taken in charge by Special Treasury Agent Wm. H. Theobald, and a search was made for smuggled goods. This search resulted in the discovery of about 40 packages of pearls, the value of which had not been ascertained up to the time THE CIRCULAR went to press. Thirty of these packages were found in three pairs of shoes, which were tied up heel to toe, 10 packages in each pair; and 10 other parcels were found on the person of the suspect and in his baggage.

Bock could not speak English, but vehemently protested when the Treasury agents seized the goods, and claimed that he was on the way to Mexico with the gems. This statement, however, the Customs officers do not believe, as it is suspected that Bock had already come in and made one trip to Providence some months ago. He was locked up over night in the Charles St. Police Station and, Monday morning, was arraigned before United States Commissioner Shields, in the Post Office building, New York. Bock was not represented by counsel, and the Commissioner held him in \$5,000 bail for examination yesterday morning.

The pearls were taken to the Appraisers' stores where an examination by Jewelry Examiner Mindil disclosed the fact that they were imitation and not real pearls. The examination of the packages also disclosed that the stones numbered about 1,000,000, about 250,000 being contained in the small packages and about three times that number in a larger package.

When the case came up for examination yesterday morning Samuel Greenbaum, of Hayes, Greenbaum & Hirschfield, appeared for Bock. On the agreement between Mr. Greenbaum and Assistant District Attorney Ball the examination was adjourned until to-morrow by Commissioner Shields. The Government agents also allege that on a previous occasion Bock smuggled a quantity of the same stones concealed in bicycle tires.

PROVIDENCE AUTHORITIES HAD BEEN WATCHING BOCK.

PROVIDENCE, R. I., Nov. 20.—Francois Bock, who was arrested by the Customs officials in New York on a charge of smuggling gems into this country, and who claimed to be a Providence (R. I.) jeweler, is known to the trade here. It was really through the information furnished by the local Custom House officials that Bock was arrested. It appears that late last Winter, or during the early Spring, Bock came to this city and opened a place of business on Burnett St. He

ESTABLISHED 1840.

**Chester Billings & Son,**

Successors to **RANDEL, BAREMORE & BILLINGS,**  
IMPORTERS OF

1840 RANDEL & BAREMORE.  
1866 RANDEL, BAREMORE & CO.  
1880 RANDEL, BAREMORE & BILLINGS.

**DIAMONDS**

OTHER PRECIOUS STONES AND PEARLS.

58 Nassau Street,  
29 Maiden Lane, 22 Holborn Viaduct,  
NEW YORK. LONDON, E. C.

DIAMOND JEWELRY.

...ESTABLISHED 1841...

A. CARTER. C. E. HASTINGS. G. R. HOWE. W. T. CARTER. W. T. GOUGH.

**Carter, Hastings & Howe,**

TRADE  MARK.

MANUFACTURERS OF

**Gold Jewelry,**

9, 11, 13 MAIDEN LANE,

NEW YORK.

FACTORY, NEWARK, N. J.

**Pearl Perfection.**

Perfect in quality, perfect in assortment, our stock of Pearls is one of the largest owned by any house in America.

**Fred. W. Lewis & Co.,**

No. 1 MAIDEN LANE (Cushman Building), NEW YORK.

**John F. Saunders,** Cutter and Importer of

**DIAMONDS** AND OTHER PRECIOUS STONES.

FINE PEARLS A SPECIALTY.

68 Nassau St., cor. John St., Sheldon Building, Room 16, NEW YORK.

## PEARLS.

### The Scope.

We do not confine ourselves to dealing in one grade of goods, but simply to dealing in one line.

We deal in everything that pertains to that line, from the most expensive to the most moderate.

The result of this thoroughness is manifest in the assortments awaiting your inspection.

### Alfred H. Smith & Co.,

182 Broadway, N. Y.

CHICAGO.

LONDON.

## DIAMONDS

And Other Precious Stones.

# NISSEN

*Ludwig Nissen.*

18 JOHN ST. NEW YORK

We carry the largest, finest and most complete line of Mounted Diamond Jewelry of any house in America.

gave it out that he would engage in the imitation pearl business and said that he represented Bock Bros., dealers in imitation stones, in Paris.

It is said that Bock imported imitation stones to some extent and that they came in in the regular way through the Custom House. Apparently there was something which aroused the suspicion of the Custom House officials here, for they began an investigation. They learned that the price of imitation pearls was being affected to an extent which seemed to them unwarranted and that this slashing of prices could hardly be brought about by the small importation of stones.

About six weeks ago Bock left this city for Paris. The Custom House officials were apprised of this move and informed the proper authorities to watch for his return. That they did so is proved by the action they took when he arrived in New York. It is learned that Bock had had transactions with various local houses.

#### Death of Edward Parmalee.

MINNEAPOLIS, Minn., Nov. 18.—Edward Parmalee, one of the best known traveling salesmen in the country, died at his home, 3058 Fifth Ave., this week. He had been ill about a week, suffering from typhoid fever.

Mr. Parmalee was 56 years of age, and leaves a son, Edward Parmalee, in the employ of the Soo Railroad Co., and a daughter, wife of the proprietor of the Plankinton hotel, Milwaukee.

Mr. Parmalee had represented the Meriden Britannia Co. many years, and enjoyed the confidence and respect of his employers and customers. Kindly in disposition, upright in character, loyal to his friends, he will be missed and mourned by all who knew him. Mr. Parmalee traveled from Milwaukee to the Pacific coast.

#### The Dwindled Assets of Vernon J. Durkee.

ROCHESTER, N. Y., Nov. 16.—Two hundred dollars is all there appears to be left of the estate assigned by Vernon J. Durkee, jeweler, to attorney Ira L. Ward, although the statement filed at the time the assignment was made, Jan. 25, 1897, gave the nominal value of the property at \$2,925.30, and the value, under attest, at \$2,600.

In explanation of the state of affairs Attorney Salisbury, who represents Assignee Ward, made the following statement: "So many open charges have been made here that I think I ought to say something in Mr. Ward's behalf. In the first place this property was believed to be worth \$2,925.30, but it was agreed to be worth about \$2,600. This included a second mortgage for about \$1,500 on certain property. This was second to another mortgage of about \$1,700. The second mortgage is still a part of the assets. When this is all investigated you will find that the accounting is all right."

The creditors have demanded an accounting.

E. L. Egolf, Harrisburg, Pa., has been proposed for membership in the Board of Trade of that city.



**Last Week's New York Arrivals.**

- Albany, N. Y., H. Miller (Miller Bros.), Belvedere.
- Boston, Mass., A. E. Clifford (Houghton & Dutton), St. Denis.
- Baltimore, Md., D. Engel (J. Engel & Co.) St. Denis.
- Buffalo, N. Y., T. Clancy (H. A. Meldrum Co.), 45 Lispenard St.
- Canton, O., J. Dannenmiller (W. D. Caldwell & Co.), St. Denis H.
- Carbondale, Pa., J. E. Burr, Manhattan.
- Danbury, Conn., F. H. Hill, Cadillac.
- Detroit, Mich., W. A. Sturgeon (W. A. Sturgeon & Co.), Imperial.
- Fairhaven, Vt., W. F. Parker, Park Ave.
- Geneva, N. Y., M. C. Haight, Normandie.
- Hagerstown, Md., W. H. Reisner, Astor.
- Hartford, Conn., M. Fox (G. Fox & Co.), 41 Lispenard St.
- Kansas City, Mo., T. J. Edwards (Edwards & Sloane J'lry Co.), Rivers.
- Middletown, N. Y., R. L. De Zeng, Manhattan.
- Montreal, Can., B. C. Silver, Astor House.
- New Haven, Conn., Wm. Reeves (optical goods), Gilsey H.
- Newport, R. I., H. A. Heath, Everett.
- New Milford, Conn., C. E. Riddeford, Albert.
- Oswego, N. Y., C. Wendell (J. Wendell & Son), St. Denis.
- Philadelphia, Pa., W. H. Thompson, Everett.
- Pittsburgh, Pa., J. H. Wattles (W. W. Wattles & Sons), Astor.
- J. A. Reed (J. R. Reed & Co.), Manhattan.
- Providence, R. I., Geo. C. Darling, Morton.
- Richmond, Va., D. Lumsden, Marlboro.
- Rochester, N. Y., H. Kirstein, Hoffman.
- C. F. Beadle (Beadle & Sherburne Co.), 438 B'way.
- Springfield, Mass., O. W. Bullock, B'way Central.
- F. E. Ladd, Broadway Central.
- Syracuse, N. Y., M. L. Mantell, Union Sq.
- Tampa, Fla., S. B. Leonardi, St. Denis.
- Utica, N. Y., F. Morath (J. B. Wells, Son & Co.), Albert.
- Washington, D. C., N. Galt, Westminster.
- M. Schuster, Sturtevant.
- Washington, Pa., A. A. Poole, Continental.
- Youngstown, O., F. T. Jeannot, B'way Central.



**"The Pearl House."**

We have no salesmen; call or write.

**EISENMANN BROS.,**

PARIS, 3 Rue St. Georges.

21 & 23 MAIDEN LANE, NEW YORK.

**Rubies and Emeralds.**

**BYRON L. STRASBURGER & CO.,**

Watches and Diamonds,

17 MAIDEN LANE,

NEW YORK.

**Pearls**

**Opals**

Importers and Cutters

**GOODFRIEND BROS.,** Precious and Imitation Stones

9-13 Maiden Lane, N. Y.

174 Weybosset St., Providence, R. I.

10 Rue Cadet, Paris.

TELEPHONE, 662 CORTLANDT.

SCIENTIFIC RUBIES  
OPALS  
OLIVINES

CATSEYES | SAPPHIRES | DIAMONDS | RUBIES | EMERALDS | PEARLS | PEARL NECKS | PEARL ROPES

**PEARLS, DRILLED AND UNDRILLED.  
PEARL ROPES, NECKS and COLLARETTES.**

**We are buyers of American Pearls.**

LONDON: **JOSEPH FRANKEL'S SONS,** 68 Nassau Street, NEW YORK.

TELEPHONE, 3899 CORTLANDT.

FANCY COLORED DIAMONDS and GEMS in PEARLS and PRECIOUS STONES.

Pearl Collarettes, mounted with Diamond Bars.

**Watchmaker Robert Otto Ordered Watch Material Under Fictitious Names.**

CHICAGO, Ill., Nov. 18.—Robert Otto, of 711 First Ave., Milwaukee, Wis., was arrested by Government officers in that city on the 16th inst., while signing for a dummy package sent by the Elgin National Watch Co., of this city, under the direction of the Post Office officials. He is charged with use of the mails for fraudulent purposes. Otto, who was a watchmaker, ordered some watch material from the Elgin company, and the goods were forwarded. A second order was also honored, but as neither was paid for in a rea-

sonable time, a third and a fourth order were turned down. Shortly afterward an order was received from Henry R. Otis, of Milwaukee, also for material only, and on the supposition that Otis was a watch inspector for a railway or something of that sort, the material was forwarded him. In looking over the outstanding material accounts a little later, Mr. Prall, of the Elgin company, was attracted to these two accounts by their size, and on further investigation noticed the similarity in the handwriting of Otto and Otis and that the words "Yours truly" were spelled the same in all the orders.

Still later the company received orders from George Fleming, Milwaukee; Paul Bunde, South Milwaukee, and G. H. Barnes, 1132 Walnut St., Milwaukee, all in the same writing as the Otto and the Otis orders. Meantime the Chicago Post Office authorities had been notified and Otto's arrest followed. He had signed at the Post Office for registered mail as both Otto and Otis and was about to sign as Barnes for the Elgin dummy package. The Illinois Watch Case Co., it is said, were also victimized for a small amount, and doubtless a number of other firms.

The Elgin National Watch Co. had filled orders from Otto amounting to \$25.58 and from Otis to the amount of \$22.38, which are larger than the run of orders usually received from repairers for material. Otto was in business at Milwaukee up to a few months ago, when he is said to have been ejected from his premises for non-payment of rent. Otto was committed for trial.

**Meeting of the Philadelphia Branch of the Jewelers' League.**

PHILADELPHIA, Pa., Nov. 18.—The Philadelphia Branch of the Jewelers' League of New York held an important meeting Thursday at the headquarters of the Philadelphia Jewelers' Club, 1225 Chestnut St. This meeting was held in response to notices sent out by the local officers of the League, Wm. H. Long, president; S. S. Kind, secretary, and Wm. G. Blair, treasurer, who are anxious to materially strengthen the organization by the acquisition of new members and the infusion of new blood and spirit.

The meeting was attended by about 50 of Philadelphia's most prominent jewelers and a delegation of members from the New York branch. Nothing definite was done owing to the rush of business accompanying the holiday trade, except to decide that after the first of the year a solicitor will be employed to canvass the local trade among wholesale and retail merchants, jobbers, salesmen and others for the purpose of inducing jewelers to join the organization and further trade interests in this city.

Matthew L. Freeman, Augusta, Ga., has been adjudged a bankrupt.

E. S. Jewell, Grand View, Ind., has been succeeded by J. E. Jewell and has removed to Tell City, Ind.

S. Zetlin, Lowell, Mass., has been succeeded by Stahl & Zetlin.

J. C. Cleis, jeweler, South Bend, Ind., has been awarded the contract for furnishing the new school buildings with clocks.

OTTO K. TREIBS.

PAUL E. TREIBS.

**TREIBS BROS.,**

68 Nassau St., New York.

CUTTERS AND IMPORTERS OF

**Opals.**

**F. E. TREIBS,**

Oberstein, Germany.

ESTABLISHED 1842.

HERMANN TREIBS.

ALBERT TREIBS.

EMIL TREIBS.

ALVIN L. STRASBURGER.

Established 1849.

SOL. KAISER.

**LOUIS STRASBURGER'S SON & CO.**

9-13 MAIDEN LANE, NEW YORK.

**...DIAMONDS...**

**PEARLS,**

**SAPPHIRES,**

**RUBIES,**

**EMERALDS,**

**MARQUIS DIAMONDS.**

CHICAGO, ILL., 103 State Street.

PARIS, 25 Boulevard Haussmann.

### Action of Interest to Manufacturing Jewelers Using Steam Power.

PROVIDENCE, R. I., Nov. 18.—A case in which jewelers will be greatly interested came up before Judge Stiness, in the Appellate Division of the Supreme Court today. The case was that of David M. Watkins & Co., vs. Forrest Greene on the complainant's petition for the granting of a preliminary injunction to keep the respondent from shutting off the steam and power in the complainant's jewelry shop, in the Greene building, which is owned by the respondent.

According to the statements of Mr. Watkins, Greene cut off a supply of steam from the shop because another firm had quit the place and it was too expensive to get up steam for one tenant. The steam was needed for a sink where metals are washed, and then forced air was required for a furnace and blowpipes. It was stated that the amount of air had been diminished and with the deprivation of the steam the business was seriously affected. Greene, it was said, had tried by every means to oust the firm, seeking to entrap them into doing something which would violate the terms of the lease and finally bringing a trespass and ejectment suit which he lost. He had made certain threats in regard to so regulating the machinery that the power furnished the firm would be decreased to such a degree as to seriously interfere with the work, it was stated.

While not all the power used by Watkins & Co. was described in the lease, it was claimed that it was provided as a matter of custom. Other jewelers stated that steam and air for all the wants of a jewelry manufactory were always supplied, even though no agreement to that effect had been entered into. One jeweler stated that Greene represented that his building was fully equipped for jewelry manufacturing and that he would furnish everything required. Charles W. Bowen, who is a landlord of premises used for jewelry business, said that it was the custom for the landlord to furnish steam and air and all appliances whether stipulated or not, as a shop without them would be valueless. Huddy & Easton, for Watkins & Co., held that the motives for the acts of Greene were to be found in the loss of another tenant and the expense of furnishing power, etc., for only one concern.

James H. Hurley stated that in his experience in securing tenants for buildings devoted to jewelry manufacture, he knew of no case where a place was let unless there was a stipulation as to what was required by the tenant. Mr. Greene said that Watkins & Co. were allowed to use the steam only while another plant had it, notice being given that after that concern left they would have to pay extra. Judge Stiness reserved his decision.

Theo. R. Staley, Pittston, Pa., is in bankruptcy.

C. O. Upper & Co., Buffalo, N. Y., are retiring from the jewelry business.

Elmer E. Starr, Toledo, O., has been adjudged an involuntary bankrupt.

The business of Theodore Kelsey, Wattsburg, Pa., who recently died, is closed.

### Notes from Near and Far.

C. Wood, Nashua, Ia., is closing out his jewelry stock.

L. Cillaway has opened a jewelry store in Lake City, Mich.

Bert Tucker has moved from Harbor Beach, Mich., to Bad Axe, Mich.

J. L. Field has purchased the stock of jewelry of Lovell & Crane, Pittsfield, Ill.

A. H. Roberts, of St. Paul, and Mr. Stauffacher, of Marysville, Kan., will open a new jewelry store in Erie, Kan.

Sarratt Bros., Toronto, O., have dissolved by mutual consent, Samuel A. Sarratt retiring and James F. Sarratt, Jr., continuing the business.

J. P. Johnston, Cleveland, Ind., has gone into voluntary bankruptcy. Mr. Johnston

formerly conducted a wholesale jewelry house in La Porte, Ind.

W. C. Maynard, of Rockville, Md., has moved his family to Kissimmee, Fla., and will open his place of business soon.

M. H. Kennedy, Erie, Kan., announces that he will sell his jewelry stock at auction, beginning Dec. 10, and that he has decided to go to Chicago.

From Preston, Idaho, is reported the robbery of the jewelry store of William Luthy, of that place. Something over \$200 worth of watches was taken.

Talitha J. Moore has begun suit against Harry W. Ewalt, formerly in the jewelry business in Mt. Vernon, O., for \$500 and interest from Oct. 15, 1889, on a promissory note given by defendant at Cambridge to plaintiff on the above date.

## Diamonds and Precious Stones.

We have a very large stock of Diamonds and Precious Stones purchased far in advance of the season, at prices which to-day are cheap. As long as they last we will give our customers the benefit of our foresight.

Do not delay making your selection, for large as our stock is, it must soon be depleted by the unusual demands which are being made upon it.

### HAYDEN W. WHEELER & CO.,

TWO MAIDEN LANE, N. Y.

LONDON OFFICE, 50 HOLBORN VIADUCT.

## The Best.

The best made, the best quality, the best guarantee, the best to handle, the best to sell. These are some reasons why you should have a line of Bell Gold-Filled Watch Cases.



Remember, on a Bell Gold-Filled Watch Case you can have any special engraving you want.

Buy of the Maker.

**THE BELL WATCH  
CASE CO.,**

**CINCINNATI, OHIO.**

### Providence.

John T. Poole has begun the manufacture of paper boxes for the trade at 167 Pine St.

B. L. Penno has withdrawn from S. J. Weeden & Co., where he was foreman of the factory.

William A. Low, formerly foreman for H. M. Williams & Co., has engaged the shop at 34 Conduit St. and will manufacture plated tubing for the trade.

In the case of Martin, Copeland & Co., vs. Wallace & Simmons, Justice Rogers handed down a decision last week in favor of the plaintiffs. The case was one of assumpsit on a promissory note for \$300, made by the defendants, payable two months after date to the order of the McCormick Co., and by the latter company endorsed in blank. The suit was brought by the holders against the makers. The Court held that the makers were liable upon the note, but the defendant Wallace being dead, judgment could only be rendered against the defendant Simmons. Decision was given against Simmons for \$327.15, with costs.

The two cases of Benjamin Hill vs. George W. Dover were heard before the full bench of the Appellate Division Monday on the petition of Mr. Dover for a new trial. The cases are actions of assumpsit brought by the payee against the maker upon a check and a note, respectively, each for the sum of \$257.50. Both were given in payment of premiums upon life insurance policies issued by the New York Life Insurance Co. The case was tried before a jury and a verdict given for the plaintiff for the full amount. Mr. Dover claims, however, that the verdict was against the evidence and upon several other reasons bases his petition for a new trial.

By the death of James G. Robinson last week, the city lost one of its oldest watch-makers. Mr. Robinson died at his home on West Clifford St. after a lingering illness. He had been in business for himself for many years, for a long time having a store on what was then known as High St., this being about 20 years ago. He also had a store on Westminster St. for a long time. Two years ago he purchased the business of Charles A. Towne, in the store of J. Putney & Co., 76 Westminster St., and had since been located there. Mr.

Robinson at one time had a store on the site of the Banigan building, when the old wooden buildings of the Grosvenor estate were standing, and one at Turk's Head. Mr. Robinson was in his 68th year.

Two jewelry cases came up for settlement in the civil division of the Sixth District Court last Thursday. The first was that of W. I. Macomber, who sued Benedict Lederer to recover the price of a set of tools used to make a collar button. Mr. Lederer claimed that an agreement was made whereby Macomber was to make a set of tools to produce a button, and if they were found all right he would receive his pay. The tools were made, but, according to Mr. Lederer's testimony, the button produced by them was defective, and they were sent back. Some alterations were made, but still they were not up to the requirements, according to Mr. Lederer and his expert, Mr. Robinson, and he refused to pay for them. The plaintiff claimed that the tools were made according to specifications furnished him. Judge Sweetland rendered a verdict for the plaintiff for the amount of the claim, \$78. The second case was that of Joseph A. Ratcliffe against Michael Fitzgerald and was tried before Clerk Rueckert. The plaintiff had a claim of \$97.50 for goods and labor, and Fitzgerald had a counterclaim of \$161.36 for money and goods which he claimed to have furnished to the plaintiff. Several witnesses were examined on either side and decision for the excess was given in favor of the defendant against the plaintiff.

### The Attleboros.

Simeon S. Wood, foreman for W. G. Clark & Co., died last week.

Arthur Hewitt has just recovered from a severe attack of appendicitis.

T. I. Smith & Co. have added a pearl cutting plant to their new factory.

W. H. Hall & Co. is the new firm name of the North Attleboro house, formerly Hall & Wilmarth.

The Plainville jewelry factories are sharing the present rush with their confreres in the Attleboros.

Charles R. Bugbee, a well known former North Attleboroan, is reported to have died in Los Angeles, Cal.

Joseph Rioux, for many years with S. O. Bigney & Co., left Saturday to accept a position with A. A. Greene Co.

**Mossberg & Granville Mfg. Co.,**

PROVIDENCE, R. I.

HEADQUARTERS FOR

**JEWELERS' AND SILVERSMITHS'  
MACHINERY.**

GRINDING AND POLISHING JEWELERS' ROLLS A SPECIALTY.

N. Y. Office, 26 LIBERTY STREET.

Exhibition at the Philadelphia Bourse

No. 5 Plain Drop Press.

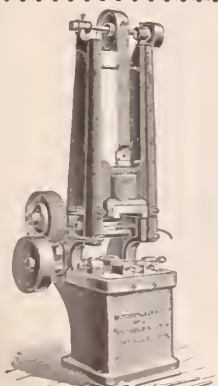

No. 5 Automatic Drop.

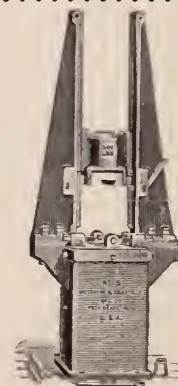

Cards are out for the wedding, Nov. 29, of James Hope Arthur, employed by A. Bushee & Co., to Miss Mary, the only daughter of Albert A. Bushee, his employer.

The Watson & Newell Co. have marked the 25th anniversary of their entrance into the jewelry field by issuing some pretty souvenir blotters, with an excellent picture of their immense factory.

The last of this month the Dunbar-Leach-Garner Co., the new plating house, expect to be installed in their quarters in the Union St. Bates building, now being vacated by the D. F. Briggs Co.

At a late hour Friday night, Francis Conolly, of Attleboro Falls, passed away at the St. Joseph's hospital, Providence, R. I. His connection with the trade was as partner in Stelle & Conolly.

Clarence and Eugene Skinner were indicted last week by the grand jury of Bristol county on three and four counts, respectively, of breaking and entering various local jewelry shops and the larceny of goods therefrom in the night.

The report which appeared in the local press, that Regnell, Bigney & Co. were about to remove to the S. O. Bigney building and that their quarters are to be occupied by Bates & Bacon with a line of chains, is vigorously denied in the offices of both interested firms.

The wedding of Ernest J. Qvarnstrom, of Carter, Qvarnstrom & Remington, took place on Nov. 15, at the home of his bride's grandfather, Captain George F. Bicknell. Among the ushers were Louis C. Luther, of J. W. Luther & Co., and William E. Richards, with the James E. Blake Co.

Henry D. Merritt has invested a part of the legacy he recently received from his father, late head of H. D. Merritt & Co., in a new industry in North Dakota. A former Attleboroan has invented a device to shorten the time required to get out flax fibre, and Merritt went west last week to look after the interests he has purchased, taking Mrs. Merritt with him.

### Canada Notes.

D. D. Bowlby, jeweler, Newbury, Ont., has removed to Alvinston.

W. J. Chambers, Hillsdale, has removed his business to Coldwater, Ont.

S. Marcon has obtained a Canadian patent for cleansing gold and silver.

John H. Feeley, gold and silver plater, Montreal, has started in business.

The Canadian Nickel Co., Ltd., Worthington, Ont., have obtained a charter.

Pope & Moore, jewelers, have commenced in business at Bothwell, Ont.

A writ has been issued by W. Bloom against F. J. Moeckel, jeweler, McGregor, Man.

A meeting of the creditors of Hughan & Co., Lindsay, Ont., took place on Nov. 14.

F. W. Vickers has sold out his jewelry business at Gladstone, Man., and purposes going to South Africa.

The jewelry imports into Montreal, including watches, amounted to \$31,382 for October, 1898, and \$45,134 for October, 1899.

J. L. Wilson, Woodstock, will shortly move into a new store specially fitted up to suit his increasing business requirements.

Arthur M. Brock, jeweler, Kingston, Ont., has given a chattel mortgage to Mills & Cunningham for \$871. This is a renewal.

At Grand Forks, B. C., a new but rapidly growing Canadian mining town, M. D. White, jeweler, has hung out his shingle on Bridge St.

The Canadian Pacific Railway watch inspectorship, at Toronto Junction, lately held by B. & H. B. Kent has been given to A. C. Stanners, jeweler, Parkdale.

Mrs. Munn, 798 Yonge St., Toronto, has erected a handsome new store, where she will carry on the jewelry business on the site formerly occupied by her late husband, James Munn.

The foreign jewelry and watches imported into Toronto in October amounted

to \$49,153, against \$29,581 for October of 1898. The glass and glassware amounted to \$31,088, against \$15,282 for October of last year.

H. Logan, Ormstown, Que., is leaving for British Columbia and contemplates setting up a jewelry establishment at Grand Forks. His business at Ormstown was an old established one, but was of small dimensions, with no opportunity for expansion.

Out-of-town buyers visiting Toronto last week included: F. D. Haight, Barrie; W. S. Frost, Orillia; W. A. Fenwick, Shelburne; F. Claringbowl, Hamilton; F. Spangenberg, Kingston; Mr. Neilly, of Neilly & Leadbetter, Aurora, and Charles Nettleton, Meaford.

### Lancaster, Pa.

L. C. Reisner, of L. C. Reisner & Co., visited the Baltimore trade last week, in the absence of one of their travelers, who is ill, and reports most excellent trade.

L. C. Reisner & Co. have rented the ground floor and basement at 111 S. 8th St., Philadelphia, for their Philadelphia business, which has grown to such an extent that they are unable to handle it in their present quarters. It is most gratifying to the firm to feel the confidence in this move that they do, from the fact that the business of this Philadelphia house has increased greatly since its purchase eight months ago. They have adopted the same principles for their branch store that they employ at home for the filling of orders, and the trade acknowledge the firm to be among the promptest people in the business. They employ none but men of high character and ability, in whom the trade seem to have the utmost confidence. This deal does not affect the Lancaster house in any way, as immediately upon its removal, the Philadelphia store will be put on its own footing, as it is now in a condition to take care of itself.

## WATCH THE TIMES, WATCH YOUR STOCK.

Watch the incoming, watch the outgoing.

AND, OF COURSE, **WATCH US FOR WATCHES.**

To satisfactorily fill the empty spaces in your watch trays,

## TRY US.

Just now in **LADIES' WATCHES**, movements and cases go together.

**C. G. ALFORD & CO.,**

# TO RETAIL JEWELERS, WARNING

## Keep Tabs on the Tags and Swivels.

When you buy Blackinton Chains the stamps on swivels tell the story.

EACH TAG AND STAMP ON SWIVEL REPRESENTS A DIFFERENT QUALITY.

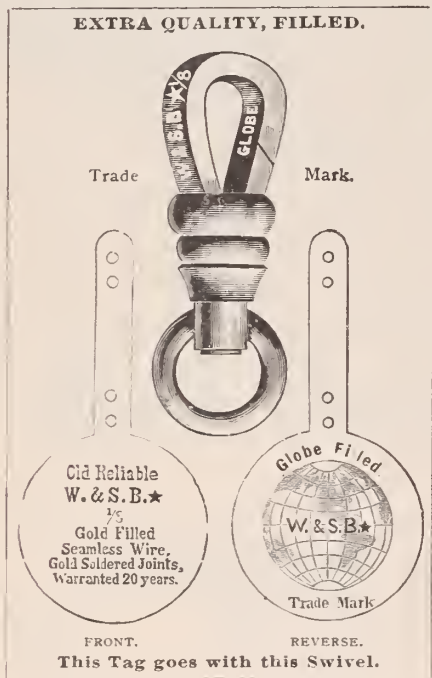

OLD RELIABLE  
**W. & S. B. ★ GLOBE FILLED**  
 ARE EXTRA QUALITY  
 AND WARRANTED TO ASSAY  $\frac{1}{8}$  GOLD.

OUR REGULAR  
**OLD RELIABLE W. & S. B. ★**  
 ARE  $\frac{1}{10}$  PLATE AND SUCH AS WE  
 HAVE MADE FOR 30 YEARS.

IF YOUR SWIVELS BEAR EITHER OF THE ABOVE TWO STAMPS YOU ARE SURE OF GETTING CHAINS THAT EXCEL IN

**QUALITY, DESIGN AND FINISH,**

THE GREATEST OF VIRTUES THAT COMBINE TO MAKE A LINE OF GOODS

**RELIABLE AND SALABLE.**

EVERY JOBBER CARRIES THESE CHAINS. INSIST ON SEEING THEM; A CAREFUL EXAMINATION WILL PROVE THE ABOVE.

Fa



MR. W. SUMNER BLACKINTON EXPLAINING THE DIFFERENT QUALITIES AS INDICATED BY THE STAMP ON THE TAGS AND ON THE GOODS.

QUALITY.

Mark.

**1 Bellable.**  
W. & S. B. ★  
Seamless Wire.

s with this Swivel.



**Each Article of this Grade  
is Stamped as above.**

**THIS IS  
OUR 2d QUALITY.**

**CAUTION**

Retailers when buying should be most careful to see that chains so stamped are not sold as either the old reliable W. & S. B. ★ **GLOBE FILLED** or the old reliable W. & S. B. ★. **THIS IS BEING DONE AND HAS BEEN DONE EXTENSIVELY.**

SECOND QUALITY.

Trade Mark.

**WARRANTED**  
14 Kt. Plate.  
Seamless Wire.

This Tag goes with this Swivel.

**W. & S. BLACKINTON.**

Providence, R. I.

New York, 14 Maiden Lane.

# A Few Suggestions.

**Do you want** your stock of Sterling Silver Ware to embrace the identical articles that are sold by Dry Goods Stores? Having in mind that the latter are sending catalogues by the thousands to the homes of your own customers, is it not a fact that the illustration of the patterns in your stock in such Catalogues makes these goods undesirable for the finer class of your patrons? Is it not true that a person of taste, desiring to make a Wedding Anniversary or other complimentary gift, would hesitate to send an article generally found in Dry Goods and Department Store Catalogues?

**If these are facts**, why not confine your purchases of Silver to the Manufacturers who deal only with the legitimate Jewelry trade, thus protecting your interests and preserving the fashionable exclusiveness of the wares in your stock, so often a feature in consummating an important sale. The productions of the **Gorham Mfg. Co.** are never sold except through the best class of Jewelers.

**They are fashionable.**

**They are exclusive.**

**Their quality is unquestioned.**

**They are not higher priced.**



## Gorham Mfg. Co.,

...SILVERSMITHS...

Broadway and  
19th Street,

☞ New York.

BRANCHES:

NEW YORK:  
21 & 23 Maiden Lane.

CHICAGO:  
131-137 Wabash Avenue.

SAN FRANCISCO:  
118-120 Sutter Street.

WORKS: PROVIDENCE, R. I., AND NEW YORK CITY.



# The Jewelers' Circular

AND  
HOROLOGICAL REVIEW.

PUBLISHED EVERY WEDNESDAY BY  
**THE JEWELERS' CIRCULAR PUB'G CO.,**  
CORBIN BUILDING, 11 JOHN ST., COR. BROADWAY,  
NEW YORK.

TELEPHONE:  
1146 CORTLANDT.

CABLE ADDRESS:  
JEWLAR, NEW YORK.

A JOURNAL DEVOTED TO THE INTERESTS OF JEWELERS  
WATCHMAKERS, SILVERSMITHS, ELECTRO-PLATE MANU-  
FACTURERS, AND ALL ENGAGED IN KINDRED BRANCHES OF  
INDUSTRY.

Member of the *American Trade Press Association.*

Our editorial columns will contain our own opinions only, and we shall present in other columns only what we consider of interest or value to our readers. Advertising matter will not be printed as news.

Advertising rates in THE CIRCULAR are lower, considering the number of tradesmen reached by its large circulation, than in any other jewelry journal.

Notices of changes in standing advertisements must be received one week in advance; new matter can be received up to Monday.

## INFORMATION FOR SUBSCRIBERS.

### Terms of Subscription, Postage Prepaid.

	PER ANNUM.
United States and Canada, - - -	\$2.00
Foreign Countries in Postal Union, - - -	4.00
Single Copies, - - -	.10

New Subscribers can commence at any time.

Payments for THE CIRCULAR, when sent by mail, should be made in a Post-Office Money Order, Bank Check or Draft, or an Express Money Order or Registered Letter. All postmasters are required to register letters whenever requested to do so.

Pay money only to authorized collectors having proper credentials.

**Returning Copies.** Returning your paper will not enable us to discontinue it, as we cannot find your name on our books unless your address is given.

**Changing Address.** In changing address always give the old as well as the new one. Your name cannot be found on our books unless this is done.

**Discontinuances** We will continue to send papers until there is a specific order to stop, in connection with which all arrearages must be paid; but such an order can be given at any time, to take effect at or after the expiration of the subscription. All such orders will be promptly acknowledged by mail.

**Liability.** The courts have decided that all subscribers to journals are responsible until arrearages are paid in full and an order to discontinue has been received by the publisher.

### THE JEWELERS' CIRCULAR IN EUROPE.

Among the places in Europe where THE JEWELERS' CIRCULAR is on file are the following:

**LONDON**—First Ave. Hotel, Holborn, E. C.; Holborn Viaduct Hotel, Royal Hotel.

**PARIS**—Hotel de L'Athene, Rue Scribe.

**LEIPZIG**—Handels-Zeitung, für die gesamte Uhren-Industrie.

**BERLIN**—Deutsche Uhrmacher Zeitung, Jäger-Strasse, 73.

**GENEVA**—Journal Suisse D'Horlogerie.

**AMSTERDAM**—Continental Club, Hotel Amstel.

**ANTWERP**—Diamond Club, Rue de Pelican.

Vol. XXXIX. Nov. 22, 1899. No. 17.

*Every line of reading matter in THE JEWELERS' CIRCULAR, with the exception of the few brief extracts from exchanges, always properly credited, is written exclusively for this journal. Each issue of THE JEWELERS' CIRCULAR is copyrighted. Permission to quote is extended to other publications provided such quotations are properly credited.*

### Protecting the Retail Dealer.

THE competition in the retail selling of jewelry exercised by the dry goods and department stores has, during the past decade, assumed large proportions and will undoubtedly increase, no matter what forces are brought against it. It is altogether reasonable, therefore, that the retail jewelers should seek protection from this competition, and several manufacturers, recognizing their claims, have overlooked the temptations of selling to the dry goods and department stores and have confined their product to the legitimate retail jewelers. The conscientiousness and fair dealing of these manufacturers, however, occasionally receive a severe shock through the ingratitude and nearsightedness of some retailer. An authentic case has been called to our notice by a firm of eastern manufacturers whose business principles have ever been of the purest and most liberal character, in which a manufacturer had been confining his business not only to retail jewelers but almost wholly to one retail jeweler. This manufacturer, noting a large falling off in purchases made by the jeweler, began an investigation which disclosed the fact that this protected retailer was buying most of his goods from a manufacturer who was supplying a large department store directly across the street from the jewelry store. The manufacturers who called our attention to this case designated it as "one of many which are gradually coming to light," but we sincerely hope that the glaringness of this case tended to exaggerate the condition in their mind. So long as the retail jeweler demands that the manufacturer confine his product to the retail jewelry trade and the manufacturer conscientiously and undeviatingly accedes to it, it is a base return of the retailer to buy goods from other manufacturers who sell to those dealers whom he claims are "illegitimate" competitors. The manufacturer who experiences two or three instances of such appreciation of his efforts to protect the "legitimate" jeweler, will be apt to think that his policy is a futile one and that those manufacturers who "make no bones" about selling their product to "any one who has the money" are on the right track.

### American Watches and Jewelry in Foreign Lands.

THE growing popularity of American clocks, watches and jewelry in foreign markets is well illustrated by a recently compiled table showing the exports in these lines during the last two fiscal years. During the fiscal year just ended the total exports of clocks amounted to \$1,043,621, as against a value of \$955,557 for the preceding fiscal year. Watches to the value of \$819,810 were exported during the fiscal year of 1899, a gain of \$47,898 over the exports of the fiscal year of 1898. Exports of jewelry during the last fiscal year were valued at \$729,194, as against a value of \$555,719 in 1898. Exports of other manufactures of gold and silver increased from \$192,061 in 1898 to \$233,962 in 1899. These interesting figures would seem to bear out the assertion that the

United States has entered upon a new industrial era. There are simply no imaginable limits to the development to which our foreign trade in the lines represented by THE CIRCULAR may, at no distant date, reasonably be expected to attain.

WE reproduce in full, in another part of this issue, a bankruptcy decision of Judge Brown, of the United States District Court for the Southern District of New York. The decision is the first on the point involved handed down in this locality, and the parties directly concerned, are members of the jewelry industry. But these facts alone did not induce us to devote so much space to the opinion. The most important feature of the decision is that it is a blow against a certain form of chicanery, which, if allowed to be exercised, would circumvent the very objects of the law. The decision is on an application to vacate the discharge of a bankrupt, already granted, on the ground that this discharge was corruptly procured by the payment of a sum of money to an opposing creditor as a consideration for withdrawing his objections to the discharge. Judge Brown carefully considers the case and remits the matter to the referee for further hearing.

### Important Action Bearing Upon Jewelers' Memorandum Sales.

BINGHAMTON, N. Y., Nov. 16.—The action brought by S. B. Schenck, jeweler of this city, against C. G. Malliet & Co., New York, was tried before Justice Sewell and a jury this week and resulted to-day in a verdict for \$5,000 in favor of the plaintiff. The suit was brought by Schenck to recover \$25,000 damages, which he alleged he suffered to his reputation in business by reason of false arrest and prosecution by the defendants.

The facts are briefly as follows: Schenck, who had been heavily in debt to Malliet & Co., failed in 1894, owing them about \$1,000. After this Mr. Malliet refused him further credit, but continued to supply him with goods on memorandum. On some of these goods Mr. Schenck did not report and finally admitted that he had sold them. After receiving no response to his demands for the return of these goods, Mr. Malliet had Schenck arrested and brought to New York in March, 1896, charged with conversion. The case went before Magistrate Wentworth, and Schenck was discharged on the ground of there not being sufficient evidence that the police court had jurisdiction. Over a year later Schenck commenced this action for damages for false arrest.

At the trial before Justice Sewell many important points were brought out, some of special interest in regard to the status of the memorandum sales. After a hard fought battle, lasting three days, the jury returned a verdict of \$5,000 in favor of Mr. Schenck. C. G. Malliet & Co. intend to appeal from this verdict and will carry the case to the highest courts if it be necessary to do so, to reverse this verdict.

The business of the late Wm. Tall, South Haven, Mich., has been succeeded to by Tall & Son.

## BUYERS' INFORMATION BUREAU.

Questions as to the makers of certain lines of goods, where to buy certain lines, where certain kinds of work are done, the owners of certain trade-marks and other matters relating to the buying branch of a jewelry business will be cheerfully answered under this department. The reader cannot ask too many questions.

LAURENS. S. C., Nov. 14, 1899.

Editor of THE JEWELERS' CIRCULAR:

Would consider it a favor if you would have some dealers in fancy goods send me their catalogues and price lists, or give me their addresses. I want a lot of medium and low priced fancy goods. Thanking you in advance,

Yours,  
W. A. JOHNSON.

ANSWER:—We furnish correspondent the following names of extensive dealers in fancy goods: Geo. Borgfeldt & Co., 3d, 4th and Wooster Sts.; A. Steinhardt & Bro., 452 Broadway; Samstag & Hilder Bros., 444 Broadway, New York. We think he can get anything he wants in the line of fancy goods from these firms, some of whom issue catalogues or sheets illustrating goods.

GOUVERNEUR, N. Y., Nov. 1, 1899.

Editor of THE JEWELERS' CIRCULAR:

I am in search of a manufacturer to make needle threaders for me; they have to be made very cheap, from brass or nickel or steel. Now, if you can give me the address of some big manufacturers that make such small articles as that it would be a great favor to me. Thanking you in advance for your kindness,

Yours truly,  
A. M. FELSON.

ANSWER:—We have made extended inquiry for manufacturers of needle threaders, but no one seems to know exactly what correspondent means. If he will send a sample of the article to Porter Bros. & Co., 68-70 Worth St., New York, who

are in close touch with manufacturers of notions, they will communicate with him anent this matter.

WATERVILLE, N. Y., Nov. 16, 1899.

Editor of THE JEWELERS' CIRCULAR:

Will you please inform me if there is such an article as a "metronome," and if so, where I may obtain it? and oblige,

Yours truly,  
W. L. HARTLEY.

ANSWER:—There is such an article as a "metronome." It is an instrument for indicating and marking exact time in music. It consists of a pendulum whose period of vibration is regulated by a shifting or sliding weight. J. Howard Foote, 31 Cortlandt St., New York, sells this article, and we have turned over the letter to him.

WATERTOWN, N. Y., Nov. 16, 1899.

Editor of THE JEWELERS' CIRCULAR:

Kindly advise us where we may find leather pocketbooks with strap attachment for passing hand through, and oblige,

Yours truly,  
J. S. BAIRD.

ANSWER:—Deutsch Bros., 14 E. 17th St., New York, make a fine line of these goods.

LOS ANGELES, Cal., Nov. 13, 1899.

Editor of THE JEWELERS' CIRCULAR:

Can you inform us where we can get rough diamonds for drilling, stone sawing etc.?

Yours respectfully,  
J. A. McINTOSH & Co.

ANSWER:—I. C. Yawger, 21 Maiden Lane, and Van Moppes & Son, 81 Nassau St., New York.

ALBANY, N. Y., Nov. 13, 1899.

Editor of THE JEWELERS' CIRCULAR:

From whom can I obtain a copy of the book entitled "A B C of Setting Glasses"? (Allen, author.) Who publishes the said work? Please mention the price. Your reply will very much oblige,

Yours truly,

JOHN J. SMITH.

ANSWER:—Julius King Optical Co., 2 Maiden Lane, New York; \$1 a copy.

DETROIT, Mich., Nov. 16, 1899.

Editor of THE JEWELERS' CIRCULAR:

Can you inform us who makes table forks, knives, spoons, etc., for one-armed people? Wish articles in sterling silver. Very respectfully yours,

ROEHM & SON.

ANSWER:—The Gorham Mfg. Co., Broadway and 19th St., New York, have the patterns for these articles but carry none of the goods in stock. We do not know of any other manufacturer who has them.

NEW BOSTON, Ill., Nov. 17, 1899.

Editor of THE JEWELERS' CIRCULAR:

Kindly inform me through the columns of THE CIRCULAR of some firm of whom I can obtain Wedgwood ware. Thanking you in advance, I am,

Yours truly,

E. M. BRAS.

ANSWER:—Davison Bros., 12 Barclay St., New York, are agents for Wedgwood ware for America.

### Progress of the Proposed Jewelers' Trust and Safe Deposit Companies.

The movement to establish a trust company and a safe deposit company in the jewelry trade, the prospectus of both of which was exclusively published in full in THE CIRCULAR, Nov. 1, is nearly consummated and the two companies may be formally organized within the next two or three weeks. It is believed that both concerns will be incorporated under New York laws.

According to Augustus K. Sloan, of Sloan & Co., who is prominently identified with the movement, the project has found great favor with the trade generally and the stock of the companies will be quickly subscribed. At the head will be a gentleman prominent in the financial world, but the president has not yet been definitely selected, though negotiations with a prominent financier are now going on.

While it is true that the plans of the companies propose the purchase of a site near Maiden Lane and Nassau St., on which is to be erected a building especially suited to the needs of the enterprises, no actual negotiations for this site, say those identified with the movement, have been made as yet. They deny the report published in the daily papers that an option had already been acquired on Maiden Lane property for the purposes named.

R. K. Smyth & Co., Newport News, Va., have left that place.

The opening of Capt. Renkl's new jewelry store, Augusta, Ga., on Nov. 14, was one of the events of the business season in that city. An orchestra, led by Prof. Burns, rendered music from 7 to 10 o'clock p. m. A delightful programme was arranged. The store is a most attractive place.

## ON MEMORANDUM



You'll have all kinds of stockings to cater to in the next few weeks, and nowhere will you get such an assortment of Diamonds and Diamond Jewelry as we can send you; but they won't last long in view of the rising market. Don't forget that our goods were bought months ago, and, notwithstanding the rises, will be sold at nearly the old prices, while they last. Anything you want—loose or mounted—"On Memo."

V. WARING, N.Y.

## CROSS & BEGUELIN

Importers and Cutters of Diamonds and Precious Stones

43 Rue de Meslay, PARIS

17 Maiden Lane, NEW YORK

**New York Notes.**

Mary Sophia Kaldenberg, the wife of Frederick J. Kaldenberg, a former well known dealer in ivory goods, pipes, etc., died at Tarrytown on Friday.

W. F. Parker, of W. F. Parker & Sons, Fair Haven, Vt., is in New York, and is making his headquarters with Eliassof Bros. & Co., 13 Maiden Lane.

The annual meeting of the Peter A. Frasse Co., dealers in jewelers' tools, 94 Fulton St., will be held at the office of the concern, Dec. 4, at 3 o'clock p. m.

Eugene Hemmendinger, diamond setter, 65 Nassau St., asks that he be not confounded with the party of a similar name against whom a judgment was entered last week.

The Rhode Island Jewelry Co., of New York, were incorporated last week, with a capital of \$10,000. David Blum, Brooklyn; S. C. Walb and L. M. White, New York, are the directors.

Gyula de Festicis is one of the directors of The Old Corner Decorating Co., who have been incorporated to manufacture stained and art glass, mantels, tiles, etc., with a capital of \$100,000.

Peter T. Lehr, police officer, of 224 W. 16th St., filed a petition in bankruptcy Friday, with liabilities of \$1,057.50 and no assets. Lehr has had several complaints against him for buying jewelry on the instalment plan and refusing payment. All debts were contracted by opening accounts in 36 different stores, with amounts due from \$7 to \$150.

On Wednesday last occurred the marriage of Miss Alice A. Robert, daughter of J. Eugene Robert, watch importer at 1 Maiden Lane, and J. Francis Booraem, of Brooklyn. The wedding took place at the home of the bride's parents, 48 W. 71st St. Only the relatives were present at the ceremony, which was performed by the Rev. Henry L. Grandlienard.

Florence Kroeber, as permanent receiver of the F. Kroeber Clock Co., 360 Broadway, is advertising for all persons indebted to or holding property of the corporation to render an account of the same to him at the office of the company on or before Jan. 3, 1900. Creditors of the firm are notified to present their claims at the same time and place, and persons holding contracts of the company are also required to present them on or before the date mentioned.

The sheriff last week received an attachment against Ivan Fox, who did business under the style of the Fox Optical Co., 41 E. 42d St., for \$424 in favor of E. &

H. T. Anthony & Co., dealers in photo supplies. It was obtained on the ground that Mr. Fox resides at Lansdowne, Pa. He has been in business for many years in Philadelphia, and has had a branch store here for several years. When the sheriff went to the store here to serve the papers he was told that Mr. Fox had sold the business Wednesday.

The Appellate Division of the Supreme Court has granted a motion by Emilie S. De Hierapolis to carry her suit against John B. Riley and others to the Court of Appeals. The plaintiff, who was a judgment creditor of Riley for jewelry purchased, sought to set aside a transfer of a fund by him to his fiancée on the ground that it was intended to hinder and defraud creditors. The judgment in Riley's favor was recently sustained by the Appellate Division of the Supreme Court, which now has permitted an appeal from its decision.

Judge Lacombe, of the United States Circuit Court, Nov. 14, signed decrees in two actions brought by the L. E. Waterman Co. against John Blair and the Diamond Point Pen Co. These suits were on alleged infringements of patents on improvements for fountain pens, and the decrees were entered by default. By the decrees the L. E. Waterman Co.'s patent is adjudged valid and has been infringed, and the defendants are restrained from further infringements and are to pay the damages suffered by the complainants from their acts as well as costs of the action.

Judge Lacombe, of the United States

Circuit Court, heard argument on motions by the L. E. Waterman Co. to amend their bills of complaint in the actions against Vassar College and John P. Ambler. The actions were for alleged infringements of patents granted on the feed devices of



**A Fountain of Satisfaction to Buyer and Seller.**

**Waterman's Ideal Fountain Pen.**

'99 styles, especially suited for Holiday Gifts, are the finest ever offered.

Don't lose the advantage to be gained by buying a full stock.

**L. E. Waterman Co.,**  
155-157 Broadway, New York.

Largest Manufacturers of Fountain Pens in the World.

While we cannot take any more orders to be made up before January 1st, we have a large and varied stock of CUT GLASS in New York for prompt shipment.

**C. Dorflinger & Sons,**

36 MURRAY STREET,

NEW YORK.

1851.

1899.

**THE CHATHAM NATIONAL BANK, NEW YORK.**

CAPITAL STOCK, - - - - \$450,000  
UNDIVIDED PROFITS, - - - - 974,518

GEO. M. HARD, President.

H. P. DOREMUS, Cashier.

W. H. STRAWN, Ass't Cashier.

fountain pens. The defendants pleaded that one of these patents expired Feb. 12, 1898, before the commencement of the action, and the L. E. Waterman Co. asked leave to amend their complaints by striking out the reference to this patent. Walter S. Logan argued for the complainants and William B. Whitney for the defendants. Decision was reserved.

A cablegram was received in this city.

## James D. Hughes, Wholesale Jeweler

Successor to F. W. Sewall,

728 Chestnut Street,

Second Floor.

Philadelphia.

### UNUSUAL OPPORTUNITY.

#### For Sale.

#### A WHOLESALE JEWELRY BUSINESS,

Established Twenty Years in  
Boston, Mass.

Stock, Good-Will, Office Fixtures, Trunks, Trays,  
and all necessary appointments.

Present firm enters different lines of trade.

This affords an excellent chance to start  
with established line of customers.

Stock will be reduced if desired.

Address "OPPORTUNITY,"

Care JEWELERS' CIRCULAR.

Monday last, announcing the death of John Daniel Brez, who died suddenly in his 64th year at the home of his sister, Mrs. Gillet, in Clarens, Switzerland. Mr. Brez was a son of Paul A. Brez, who, for nearly half a century, was a leading watch importer of New York up to the time of his death, May 1, 1878. Upon the death of his father the deceased closed the watch business, and since that time till his death was in the general brokerage business.

A. Geoffroy sailed for Europe Saturday on *La Gascogne*.

John Treherne and Geo. Taylor were before United States Commissioner Alexander, Monday, charged with smuggling photographic lenses and other apparatus valued at over \$200. Taylor is an officer on board the *Etruria*, which arrived Sunday, and Treherne is a friend who went down to meet the boat. The latter stated that he had been asked by Taylor to carry a package up to the city for him, and, without suspecting there was anything wrong about it, agreed to do so. As he was about to go off the boat, he was stopped by Custom Officer Kruckman, who detained him and found out where he had obtained the package and arrested him and Taylor. Commissioner Alexander held both prisoners in \$2,500 bail.

Collector Bidwell, of this port, yesterday afternoon, as THE CIRCULAR was going to press, gave a hearing at the Custom House upon the question of the release of the diamonds and precious stones belonging to Adolph Peabody, which have been detained at the Custom House on a charge that they were technically smuggled. At

this hearing, the complainant was given an opportunity to identify such of the diamonds as he claims were cut in this country. The question of the release of the goods identified as American cut, it is said, has been left by the Treasury Department to the discretion of Collector Bidwell. At this hearing Ex-Judge Dittenhoefer appeared for Mr. Peabody, and the Government's interests were looked after by Col. D. F. Phelps, Deputy Collector in charge of the Law Division of the Custom House.

#### Mysterious Disappearance of O. R. Ryan's Trunk.

CHICAGO, Ill., Nov. 20.—The sample trunk owned by O. R. Ryan, the traveler for the Towle Mfg. Co. whose death occurred in Oshkosh, as reported in THE CIRCULAR last week, is missing. It contained \$3,000 worth of silver ware used as samples. No checks for his trunks were found on his person. No clue to it has been found up to date.

Robbers broke a large plate glass window, Nov. 15, in the Deadwood Loan Co.'s jewelry store, Deadwood, S. D., and got away with all the valuables in sight.

In the Muncie, Ind., Circuit Court Monday B. C. Bowman was appointed receiver for the Ontario Silver Ware Co., furnishing a bond in the sum of \$75,000. The works are considered one of the most stable industries in Muncie, and the application for a receiver was simply to assist in settling the estate of the late Dr. Clark, of Buffalo, a large stockholder.



EIGHT-DAY PARIS No. 2.  
Beveled Glass on Front, Rear and Sides.  
HEAVY GILT, HEIGHT 13½ inches.

## THE F. KROEBER CLOCK CO., IN LIQUIDATION

ARE DISPOSING OF THEIR LARGE STOCK OF  
CHOICE

### Eight-Day and One-Day Clocks

CONSISTING OF

Porcelain, Iron, Bronze, Gilt and  
Wood Clocks

AT A

## REDUCTION

INSTEAD OF AN ADVANCE.

SALESROOMS AT

360 BROADWAY, - - NEW YORK.

# Special Notices.

## Situations Wanted.

**YOUNG MAN** wants position as stock clerk in jewelry house; has had three years' experience. Address C. N. K., care Jewelers' Circular.

**WATCHMAKER** Expert on fine work would like to exchange his position; satisfactory reasons given. Address "Escapement," care Jewelers' Circular.

**WANTED**—Position as assistant watchmaker and French clock repairer, also act as salesman; first-class references. W. J., 99 Central St., Springfield, Mass.

**PRACTICAL DESIGNER**, with 15 years' experience in all branches of sterling silver ware, desires position; AI references furnished. Address "Sterling," care Jewelers' Circular.

**WANTED**—Position by one who has represented factory lines for 20 years, west of Chicago to the coast; reference given to the best people on the territory; good reasons given for making a change. Address J., care Jewelers' Circular.

**AI OPTICIAN**, watchmaker and engraver wants a steady position with a good firm; understands the business thoroughly; young man, single, sober and steady; have tools and trial case; state salary in first letter; AI references. Address "Optician," care Jewelers' Circular.

## Help Wanted.

**WANTED**—Salesman for southern and southwestern trade. Zimmern, Rees & Co., 9-13 Maiden Lane, New York.

**WATCHMAKER** and engraver wanted in a town of Pennsylvania. Apply to David Marx, 54 Maiden Lane, New York.

**WANTED**—An experienced designer on sterling silver hollow ware and novelties. Address "Silversmith," care Jewelers' Circular.

**WANTED**—A good reliable watchmaker; also hard solderer; \$12 a week, with advance; steady work guaranteed. Address Box 59, Stamford, Conn.

**WANTED**—A good watchmaker and engraver; must be competent; permanent position to right party; wages according to ability and capacity. P. W. T., care Jewelers' Circular.

**WANTED**—Two first-class manufacturing jewelers and stone setters; one first-class engraver and jeweler; references required. Geo. Wettstein, manufacturing jeweler, Cedar Rapids, Iowa.

**WANTED**—An experienced traveler for the Eastern, Middle and Southern States to sell a general line of watches, diamonds and jewelry. R., L. & M. Friedlander, 30 Maiden Lane, New York.

**AT ONCE**—First-class watchmaker, jewelry repairer and to wait on trade; references from former employers; steady job to the right man; salary according to ability. Address Box 121, Hopkinsville, Ky.

**WANTED**—Salesman, capable, young, energetic, experienced, for the northwest, by live jewelry and novelty house; good salary; must have best of references and clean record; acquaintance with trade preferable; give full information and references in first letter. "American," care Jewelers' Circular.

**WANTED**—A first-class traveling salesman for an up-to-date and live line of solid gold and gold-filled jewelry suitable for the best and medium trade; only one having a good connection and a past record need apply; good salary to the right man. Apply at once to J. & B. C. Silver, Lorsch Building, Maiden Lane, New York, or to our Montreal office.

## Business Opportunities.

**FOR 30 DAYS** I offer my jewelry business, or fixtures only, at a very low price; I have been established 35 years. Wm. F. Wallace, Westerly, R. I.

**AN EXCELLENT OPPORTUNITY**; an old-established jewelry store for sale, with or without stock; or store with fixtures; on account of death of the proprietor. Mrs. O. Zamow, 255 First Ave., New York.

**A BARGAIN**—For sale, an old estate and fine jewelry store, with complete stock and fixtures, in a good manufacturing town in the vicinity of New York; only \$2,800. Address U. B., care Jewelers' Circular.

**JEWELRY STOCKS BOUGHT**—Retailers wishing to dispose of surplus or entire stock of diamonds, watches and jewelry can find quick, cash, strictly confidential buyer by addressing S. Marx, 22 Lispenard St., New York City.

## INDEX TO ADVERTISEMENTS.

Aikin, Lambert & Co.....	51	Kohn & Co.....	21
Aikin, Lambert Jewelry Co.....	51	Kohn, Alois, & Co.....	16
Alford, C. G., & Co.....	29	Kroeber, F., Clock Co.....	39
American Watch Case Co.....	51	Lady Racine.....	49
American Waltham Watch Co.....	6	Le Boutillier & Co.....	60
Arnstein Bros. & Co.....	60	Lederer, S. & B., Co.....	60
Atlas Watch Co.....	43	Ledos Mfg. Co.....	51
Avery & Brown.....	16	Lelong, L., & Bro.....	60
Ball, Wm. H., & Co.....	58	Lewis, Fred W., & Co.....	23
Bassett Jewelry Co.....	4	Levy, L. W., & Co.....	39
Bell Watch Case Co.....	23	Lind, Thomas W.....	41
Billings, Chester, & Son.....	28	Lorsch, Albert, & Co.....	60
Blackinton, W. & S.....	30, 31	Mabie, Todd & Bard.....	56
Bonner & Co.....	47	Malliet, C. G., & Co.....	22
Bowden, J. B., & Co.....	22	Mathews & Prior.....	39
Bradley Polytechnic Institute.....	60	Mathey Bros., Mathez & Co.....	56
Bradley & Hubbard Co.....	56	Mauser Mfg. Co.....	12
Bryant, M. B., & Co.....	58	Mercantile National Bank.....	20
Carter, Hastings & Howe.....	23	Mossberg & Granville Mfg. Co.....	28
Chatham National Bank.....	35	Mount & Woodhull.....	22
Clark & Coombs.....	56	Myers, S. F., Co.....	58
Cross & Reguelin.....	34	Neuhaus, Theodore, & Co.....	44
Crossman, Charles S., & Co.....	16	New England Watch Co.....	19
Crouch & Fitzgerald.....	59	Nissen, Ludwig, & Co.....	24
Crown and Lion Watch Cases.....	16	Omega Watches.....	11
Day, Clark & Co.....	46	Oppenheimer Bros. & Veith.....	22
Deitch Bros.....	9	Patek, Phillippe & Co.....	52
Didisheim, Hipp., & Bro.....	21	Philadelphia College of Horology.....	18
Doll, Wm. F., Mfg. Co.....	38	Potter, Wm. K.....	40
Dorflinger, C., & Sons.....	25	Powell, S. C.....	38
Dubois Watch Case Co.....	56	Providence Stock Co.....	60
Dueber-Hampden Co.....	15	Reichhelm, E. P., & Co.....	51
Eaton & Glover.....	47	Reisner, L. C., & Co.....	3
Eisenmann Bros.....	25	Remington Typewriters.....	59
Eliassof Bros. & Co.....	46	Rich, H., & Co.....	60
Esser & Barry.....	47	Rogers, Wm., Mfg. Co.....	59
Fahys, Jos., & Co.....	45	Roy Watch Case Co.....	49
Fairchild & Johnson Co.....	60	Rumpp, C. F., & Sons.....	46
Field & Beattie.....	56	Saunders, John F.....	23
Foster, Theodore W., & Bro. Co.....	2	Schulz & Rudolph.....	51
Frankel's Sons, Jos.....	25	Selwyn Importing and Trading Co.....	47
Freund, Henry, & Bro.....	38	Sherwood, John W., & Co.....	14
Friedlander, R., L. & M.....	60	Simmons, R. P., & Co.....	39
Fuchs, Ferd., & Bros.....	56	Simmons & Payne.....	59
Goodfriend Bros.....	25	Simons, Bro. & Co.....	51
Goodnow & Jenks.....	2	Smith, Alfred H., & Co.....	24
Gorham Mfg. Co.....	32	Smith, Wm., & Co.....	46
Gregory, E. J.....	59	Stern Bros. & Co.....	40
Harris & Harrington.....	59	Sternau, S., & Co.....	18
Haskell, H. C.....	40	Strasburger, Byron L., & Co.....	25
Hayden Mfg. Co.....	56	Strasburger's Son, Louis, & Co.....	26
Hedges, Wm. S., & Co.....	22	Street, Geo. O., & Sons.....	46
Heimberger & Lind.....	51	Susfeld, Lorsch & Co.....	48, 52
Holmes & Edwards Silver Co.....	44	Towle Mfg. Co.....	44
Howard Sterling Co.....	7	Trebb Bros.....	26
Hraba, Louis W.....	47	Trenton Watch Co.....	18
Hughes, James D.....	39	Wadsworth, G. F.....	44
International Silver Co.....	5	Waite-Thresher Co.....	59
Jacot & Son.....	59	Wallace, R., & Sons Mfg Co.....	17
Juergensen, Jules.....	51	Waterman, L. E., Co.....	35
Kahn, L. & M., & Co.....	60	Westphal, W. C. A.....	59
Kahn's Sons, James.....	39	Wheeler, Hayden W., & Co.....	27
Kendrick & Davis.....	47	Whiting, F. M., & Co.....	11
Ketcham & McDougall.....	59	Wittnauer, A.....	13
Knowles, Dr.....	56	Wood, Chas. F., & Co.....	60
Knowles, J. B. & S. M., Co.....	10	Wood & Hughes.....	56
		Woods & Chatellier.....	39

## For Sale.

**RARE BARGAIN**—A No. 1 Moseley lathe, 11 chucks, counter shaft, freeing tool, slide rest and universal head. W. J. Eddy, L. B. 462, No. Adams, Mass.

**FOR SALE**—3 8-ft. show cases, \$25 each; 1 5-ft. 6 in. show case, \$18; these cases are 16 in. high, 24 in. wide, black enamel wood, all plate glass, including mirrors; good condition; 1 oak wall case, 25 ft. long, 6 ft. high, 20 in. deep, 30x50 plate glass mirrors, all lined with black felt; double thick glass in lift sash; medium condition; \$50. The Ruddy Jewelry and Optical Co., 145 State St., New London, Conn.

## To Let.

**LOFTS**—Large and light, for manufacturing purposes; Spring St., near W. Broadway; vacant after Jan. 1; very cheap rent. Edward F. S. Clegg, 99 Nassau St., New York.

**TO LET** for manufacturing purposes, upper floor N.W. corner Maiden Lane and Nassau St., 25x50 feet; elegant light; cheap rent; five H. P. electric motor now in operation; also work benches and fittings if desired; just the thing for manufacturing jeweler. Inquire of H. Kohibusch, Sr., balance manufacturer, 59 Nassau St., New York.

## Miscellaneous.

**WANTED**—A jewelry manufacturer to share the expense of a New York office, and salesman to cover New York State and Pennsylvania; gold or silver or chain house preferred. P. O. Box 166, Providence, R. I.

**WHEN WANTING a good lathe**, remember the "Moseley"; there is none better, many not as good; their reputation has been built up by good design and good workmanship with very little waste; wind alone will not do it; send for our new illustrated circular. When interested, write your jobber, or Moseley Lathe Co., Elgin, Ill.

## TO RENT in Silversmiths' Building, CHICAGO.

A fine office on Wabash Avenue front, with north and east light, 20 x 42 feet, adjoining the Gorham Mfg. Co.'s salesroom on the sixth floor. Most desirable location in the city. For terms apply to

**GORHAM MFG. CO.,**

Silversmiths' Building, CHICAGO.

**SALESMAN** to travel south wanted with an up-to-date line of medium price Solid Gold Jewelry (Diamond set, &c.), extensive line of Sterling Novelties and high-grade Gold-Filled Vest Chains, Lorgnette Chains, Dumb-bell Links and Brooches. Salary, \$2,000 and expenses. Don't answer this unless you have established trade south, and can furnish high-grade references.

Address with particulars, "WIDE AWAKE,"

Care of JEWELERS' CIRCULAR.



American Gun Metal, Loaded with American Lead. Every Customer buys one to 1-2 doz. You want a gross at \$18.00.

**AMERICAN GUN-METAL, NON-MAGNETIC WATCH CASES,**

fitted with special American movements. Also U. S. Battleship "Maine" cases, advertised in leading magazines at \$5.00 to \$15.00 each, cost you \$24.00 doz.; ladies' size, \$27.00 doz. Order now to insure delivery.

**AMERICAN GUN-METAL VEST CHAINS,**

small, plain, neat patterns on attractive chain pads, advertised to sell at \$1.00 each. You want sample dozen at \$4.50. Ladies' Guard Chains at \$6.00 doz., retail at \$2.00 each.

Only a limited number can be made. Many will be disappointed on account of not being able to get samples.

**W. F. DOLL MFG. CO.,**

9-13 Maiden Lane, New York.



NAVY YARD, NEW YORK.

June 23d, 1899.

This certifies that W. F. Doll Manufacturing Company purchased from the Government at public sale on the 9th of June, 1899, four (4) breech-loading 30 pdr. rifles, Nos. 17, 41, 121 and 126—weighing 13,600 pounds. W. C. GIBSON, Commander, U. S. Navy, in charge delivery stores sold at Public Sale.

**Philadelphia.**

Wm. S. Yarnall, optician, Media, Pa., was married last week to Susan V. Watson, this city.

James W. Barry, secretary of the Jewelers' Club, is reported to have entered the insurance business.

John Haas, of C. R. Smith & Son and a member of the Horological Society, was married last week.

Frederick Kruger, watchmaker, has left the employ of C. R. Smith & Son to accept a position with Geo. W. Russell.

The Philadelphia Horological Society held a meeting Thursday last at which it was decided to have a lecture followed by an entertainment in January next.

Julian Watson, an expert clock setter and maker, widely known in the trade here and employed in Wanamaker's, died Nov. 13 at his home, 3840 Terrace St., aged 40 years. Mr. Watson was an artisan of rare ability and was employed to repair and set valuable historical, town and tower clocks in Philadelphia and nearby cities.

**Boston.**

E. A. Cowan started south on a business trip on Monday of last week, to be absent through the holiday season, and possibly until after New Year's.

A. Stowell & Co., retailers, have been incorporated under the laws of Massachusetts, with the name of A. Stowell & Co., Incorporated. Capital stock is set at \$200,000, with a par value of \$100 per share. Charles S. Cook is president and treasurer.

F. C. Babbitt, formerly of Faulkner Station, Malden, and previously well known in this city by reason of his connection with the retail house of Wilson Bros., has formed a partnership with his nephew, C. M. Godsoe, opening a store at 1022 Washington St., Boston, under the firm name of Babbitt & Godsoe.

An interesting contribution to trade prosperity facts is furnished by a representative of the American Waltham Watch Co., who says that the buyers of leading Boston jobbing houses are frequently at the office of Robbins, Appleton & Co., selling agents for the manufacturers, at an early hour in the morning, awaiting the arrival of watch movements and anxious to learn what their allotment from the package is going to be. Demand outruns supply, and the vaults of the company, which are usually well filled at this season of each year in anticipation of the holiday requirements, are now nearly depleted of available stocks.

The action brought by the Meyrowitz Mfg. Co., New York, against Wm. H. Eccleston and Lyman H. Sibley, Southbridge, Mass., came up for argument yesterday before Judge Colt, in the U. S. Circuit Court, in this city. The suit is over an alleged infringement of a patent granted to Emil B. Meyrowitz Nov. 3, 1885, for improvements in spectacle frames. An injunction and damages are asked. The principal defence of the defendants is laches on the part of the plaintiffs, though the usual allegations of non-infringement and invalidity of the patent are also set up. H. A. West appears for the complainants and Oliver R. Mitchell for the defendants.

**NOW WHEN YOU RECEIVE A SPECIAL ORDER**

*for something you may not just have in stock—a fine watch or piece of jewelry or some loose diamonds—write or wire us. Goods by return express—you can depend on it. Many jewelers know this by experience. We should also like to demonstrate it to you.*

**HENRY FREUND & BRO.,**  
11 Maiden Lane, NEW YORK.

**ELK GOODS A SPECIALTY.**

**S. C. POWELL, 51 & 53 Maiden Lane, New York.**  
.... STERLING SILVER NOVELTIES ....



**HEARTS.**  
Sterling Silver.  
No. 80. Per dozen, = \$1.00



**SOLID GOLD CUFF BUTTONS.**  
Special.  
No. 993 Price, per pair, \$1.25  
Sterling Silver.  
No. 993 1/2. Per doz. pairs, 2.00



**NAPKIN RING.**  
Sterling Silver.  
No. 771. Price, each, = 50c.



**EMERY.**  
Sterling Silver.  
No. 602. Price, doz., = \$1.75



**TIE CLASP.**  
No. 01170.  
Sterling Silver, per doz., \$2.00  
Solid Gold, each, = 1.00  
" " Diamond set, 1.50



**VINAIGRETTE or GLOVE SCENTS.**  
Sterling Silver Screw Tops.  
Assorted Shapes.  
No. 915. Per doz., = \$4.50

Above prices subject to six per cent discount. Send for our New Catalogue.

## Our Traveling Representatives



Traveling representatives may consider these columns open for the publication of any news or items of interest regarding themselves or their conferees.

Traveling men seen in Indianapolis, Ind., last week were: Edward Manheimer, Illinois Watch Case Co.; F. R. Sheridan, Horton, Angell Co.; George C. Booth, Hutchison & Huestis; Ernest Block, W. & S. Blackinton; I. Price, Byron L. Strasburger & Co.; George Frey,

Ford & Carpenter; J. Charles Becker, Jos. Fahys & Co.; H. J. Fink, for David Marx.

Alf. Eaves, traveler for Edmund Eaves, Montreal, is on his usual Fall trip to the Eastern Townships.

T. A. Brady, representative in Canada of Smith, Patterson & Co., is laid up with a severe attack of rheumatism.

A. S. Holly, representative in the big cities for the Towle Mfg. Co., stopped over in Chicago for a couple of days last week.

Sidney Josephs, representing Eliassof Bros. & Co., New York, was in Chicago last week with reports of an excellent business.

J. E. Dyke, traveler for P. W. Ellis & Co., Toronto, in eastern Canada, is out on the road and making a successful journey.

W. C. X. Hull, of the Towle Mfg. Co., will finish the trip interrupted by the death of O. R. Ryan, and will be in Wisconsin this week.

T. P. Bowen, representative of Jas. Eastwood, New Glasgow, N. S., in Toronto, was in Montreal a few days ago with a special line of his firm's goods.

Max Huss, with S. & A. Borgzinner, is out again after having been confined to his home at Mount Vernon, N. Y., with a gathering in his ear and a boil on his neck.

Benj. Westervelt spent last Sunday at his home at Mount Vernon, N. Y. He was out on the "warpath" again Monday morning and says this Fall was made for hustlers only.

Willie Hayes, traveler for Alfred Eaves, Montreal, is in the Ottawa district. This firm finds business very good, especially in the watch department, the orders for watches exceeding anything before experienced.

The following traveling men interviewed the jewelers of Portland, Ore., the past week: H. C. McConnell, C. G. Alford & Co.; Chas. L. Trout, Chas. L. Trout & Co.; Fred S. Davis, Nordman Bros., and W. P. Hammatt, Whiting Mfg. Co.

Mr. Backley, representative of the American Watch Case Co., Toronto, is visiting Montreal and eastern Canada. L. Herbert Luke, traveler for Ambrose Kent & Sons, Toronto, attended the recent inauguration of the Masonic order, the Mystic Shrine, in Montreal.

W. F. Macomber, traveler for E. A. Cowan, Boston, Mass., has just returned from a southern tour which lasted three months to a day. He reports excellent business throughout the territory covered, and extended his journey to Texas, after visiting the principal Gulf cities.

Among the travelers in Kansas City, Mo., last week were: A. J. Baum, Rothschild Bros.; S. W. Abbey, E. Ira Richards & Co.; De Lancy Stone, Shafer & Douglas; E. Thompson, Derby Silver Co.; A. J. Hatfield, Jordan Cutlery Co.; Thos. E. Rogers, Riker Bros.; R. Guntzberger.

The Jewelry Travelers' Association of New England will probably hold their annual meeting and midwinter banquet between Christmas Day and New Year's. The Executive Committee have the matter under consideration, but have not as

## Gifts for Men



In 14-Karat Gold—ORNAMENTED WITH PRECIOUS STONES—and in Sterling Silver. Goods that appeal to refined people at all times. Made handsomely, heavy and exclusively for the Jewelry trade.

**Woods & Chatellier,**  
Gold and Silversmiths.

860 Broadway, N. Y.  
42-46 Hill St., Newark, N. J.

## MATHEWS & PRIOR,

DESIGNERS AND MAKERS OF

## Sterling Silverware

TO THE LEGITIMATE

## JEWELRY TRADE ONLY,



245-247 West 28th Street,  
New York City.

## "GESSOART" DISPLAY FIGURE.

18 Inches High.

DECORATIONS IN APPROPRIATE COLORS.

This unique, attractive and useful article, used in the show window for special display of all manner of articles; or can be sold as a card receiver.

PRICE, BOXED, \$2.50; NET CASH WITH ORDER.

**L. W. LEVY & CO.,** Novelties and Optical Goods,

194 BROADWAY, NEW YORK.

Successors to Levy, Dreyfus & Co.



**BUY "Simmons" CHAINS THEY SELL!**  
RFSIMMONS & CO. ATTLEBORO, MASS. N.Y. 9-13 MAIDEN LANE.

## JAMES KAHN'S SONS,

PARIS: 7 RUE CADET.

IMPORTERS AND CUTTERS OF DIAMONDS,

Amsterdam, 2 Tulp Straat.

12, 14 & 16 John St., New York.

# "THE AMERICAN BEAUTY"



IN

## Sterling and Essex

UNEQUALED.

## Hayden Mfg. Co.,

21-23 MAIDEN LANE,  
NEW YORK.

yet determined which hotel will be selected as the place of meeting.

Eastern jobbers and manufacturers represented in the Twin Cities the past week were: Albert Berger & Co., by H. Somborn; Sussfeld, Lorsch & Co.; by Jos. Frank; F. W. Gesswein Co., by Mr. Moore; L. Black & Co., by J. Segal; Martin, Copeland & Co., by Mr. Bleecker; Theodore W. Foster & Bro. Co., by J. A. Limbach.

Among the Cincinnati, O., travelers who went home last week to stock up, having sold out their entire stock, were: S. Lindenberg, of Bene, Lindenberg & Co.; A. Herman, of Herman & Loeb; Isa Schroder, of A. C. Schwab & Bro.; Jonas Wise, of Frohman & Co.; Eli Gutman, of L. Gutman & Sons. They all report the best trade they ever had.

Travelers visiting the Hub last week included: Fred L. Martin, Eichberg & Co.; Mr. Peck, Waite, Thresher Co.; Charles Bennett, Jacob Bennett & Son; Frank Jeanne, William S. Hedges & Co.; Mr. Byron, Whiting Mfg. Co.; Ed. Eckfeldt, Eckfeldt & Ackley; W. E. Hayward; John L. Shepherd, Keystone Watch Case Co.; P. L. Witzell, L. Straus & Sons.

The following traveling men were in Omaha, Neb., last week: Eugene Hoge, formerly with Fox & Stendicke, but now with the Cosy Camera Co.; M. F. Thornton, Ed. Todd & Co.; John O. Slemmons, J. B. Bowden & Co.; E. A. Tyler, Ansonia Clock Co.; J. M. Morrow, American Watch Case Co.; Will H. Maire, with Duerber Watch Case Mfg. Co.; E. B. Frank, Pairpoint Mfg. Co.

C. D. Maughan, representing the Goldsmiths Stock Co., Toronto, returned a few days since from an extended and highly successful trip to the northwest and British Columbia. He reports everything prosperous and the trade anticipating larger returns than the previous season and disposed to purchase freely, with a specially heavy demand for sterling silver goods. Mr. Maughan left on the 15th on a tour to the Lower Provinces.

The following traveling salesmen passed through Detroit, Mich., last week: Rudolph Liebman; Richard C. Rhode, Bawo & Dotter; S. C. Howard, Dominick & Haff; C. H. Higbee, Potter & Buffinton; Frank F. Gibson, for William Kinsheri; A. J. Sherrard, Enos Richardson & Co.; Chas. B. Bartlett, Whiting Mfg. Co.; H. W. Sherrill, Sinner & Sherrill; Samuel Heller, L. Heller & Son;

M. Ginsberg; A. W. Levy, Byron L. Strasburger & Co.; J. Rothschild, Ingomar Goldsmith & Co.; P. M. Layman, Riker Bros.; W. H. Gregory, Strobell & Crane; Harry Osborne, R. Wallace & Sons Mfg. Co., and a representative of J. W. Grant & Co.

Among travelers in St. Louis, Mo., last week were: F. C. Steimann, F. C. Steimann & Co.; W. A. Peck, O. W. Bullock & Co.; Mr. Parker, Osmun-Parker Mfg. Co.; Mortimer C. Adler and I. Price, Byron L. Strasburger & Co.; Hy. Freund, Henry Freund & Bro.; Frank L. Wood, Ludwig Nissen & Co.; J. R. Graham, Merrill Bros. Co.; Wm. Rosenberger, A. Wallach & Co.; M. Baum, Rothschild Bros.; S. W. Abbey, E. Ira Richards & Co.; Walter S. Noon, W. F. Cory & Bro.; John F. Garland, L. H. Keller & Co.; Frank E. Wallis, Thos. W. Adams & Co.; J. E. Simonson, A. J. Hedges & Co.; W. F. Adams, Simpson, Hall, Miller & Co.; Laurence H. Smith, Bippart & Co.; Chas. Perret, Julius Racine & Co.; Ernest Block, W. & S. Blackinton; Ed. Mumford, Waite, Thresher Co.; Fred Kennon, John T. Mauran Mfg. Co.

Travelers in Pittsburgh, Pa., recently were: D. Skutch, New Haven Clock Co.; William Matschke, F. & F. Felger, and A. Joralemon & Son; F. Van Olinda, the New England Watch Co.; Leo Henle, Sussfeld, Lorsch & Co.; George W. White, William S. Hicks' Sons; E. H. Pelletreau, Shafer & Douglas; S. C. Howard, Dominick & Haff; T. H. B. Davis and W. R. Eliot, International Silver Co.; Edward J. Hauck, William Schimper & Co.; C. N. Perley, Alling & Co.; Abel King, I. Emrich & Co.; Robert B. Steele, J. B. Bowden & Co.; A. H. Oakley, Thornton Bros. and Walter E. Hayward; Mr. Parker, Osmun-Parker Mfg. Co.; Charles C. Orcutt, Chester Billings & Son; J. E. Simonson, A. J. Hedges & Co.; Ray Randall, Riley, French & Heffron; J. W. McClannin, International Silver Co.; W. K. Helmbold, National Optical Co.

## San Francisco.

### TRADE CONDITIONS.

The demand for jewelry, watches, etc., has been so great here this season that jobbers are running short on a number of lines. The greatest need is for watch movements. Jobbers are short on these and do not seem able to get them. The holiday trade is in full swing with the wholesale establishments. Retailers are not so busy, but report good sales for this early in the season.

L. C. Koberg, Healdsburg, Cal., was a trade visitor in town last week.

E. B. Dana, of Carter, Hastings & Howe, New York, was in San Francisco last week, his headquarters being at Lick house.

Henry M. Abrams, of M. L. Levy & Co., is on a trip through Arizona and New Mexico. He is doing a good business.

It is announced that Frank M. Jackson, formerly in the retail business at Los Gatos, Cal., has removed to Redwood City, Cal.

Among the jewelers in town last week were G. Naher, Fresno, Cal.; J. C. Wahlen, Petaluma, Cal., and R. C. Richmond, Arcata, Cal.

M. Ehrenberg, formerly with G. Aronson but now a member of Lehrberger & Warkheim, reports that his firm are doing an unusually heavy business.

A. Hirschman, retailer, 10 Post St., has on exhibition a gold nugget weighing

## Survival of the Fittest.

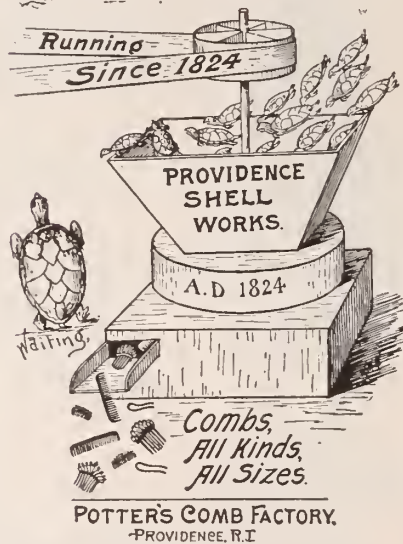

**We Grind for You,  
Send along your Work.**

## Stern Bros. & Co.,

Cutters of...

MANUFACTURERS OF

### DIAMONDS,

### Gold Rings and Thimbles,

68 NASSAU STREET, NEW YORK.

RING FACTORY, 33-43 GOLD STREET, NEW YORK.  
DIAMOND-CUTTING WORKS, 142-146 W. 14TH ST., NEW YORK.

LONDON OFFICE, 29 ELY PLACE.  
CHICAGO OFFICE, 149 STATE ST.



27 1-8 ounces, which was brought from Cape Nome, Alaska, by C. S. Rosener. This is said to be one of the largest nuggets taken from the Alaskan gold fields.

H. Blitz, a San Francisco jeweler, was arrested in this city on Nov. 12 for violating a city ordinance forbidding passengers on street railways giving away transfer checks. Mr. Blitz is said to have given his transfer to a newsboy. The ordinance is to be tested in the courts.

Autopsy Surgeon Zabala, who held an autopsy upon the body of William Hogg, jeweler, who was supposed to have been buried in the potter's field as John Doe, announced that the autopsy disclosed the fact that the body had not been buried by City Undertaker Hagan, but had been placed in the pickling vat of a medical college preparatory to dissection. The cause of death was found to be cerebral hemorrhage, and was not due to violence.

**Pittsburgh.**

R. P. Hall, Braddock, Pa., has sold out and will retire temporarily from business.

Charles T. Ahlborn, lately in business for himself, is now with Samuel Sipe, as diamond setter.

A. E. Siedle is holding an auction sale, conducted by Harry Moore, in the new store on Market St.

Carl H. Leighner has opened a new store in Butler, Pa., having purchased his stock in Pittsburgh. He will run an optical department.

J. Harvey Wattles, who has charge of

the sterling silver ware department of W. W. Wattles & Sons and who goes abroad annually in search of foreign novelties, is east, visiting the importers and silversmiths in New York, Boston, Providence and Baltimore.

William R. Blair, referee in bankruptcy, notified the creditors of George W. Biggs & Co., on Nov. 14, that the petition of James M. Stoner, Jr., trustee of the Biggs estate, had been filed praying for an order of court to sell certain real estate belonging to the bankrupts, and that the petition will be heard at a Court of Bankruptcy on Nov. 28 at 3 o'clock p. m. in Room 25, St. Nicholas building, 450 Fourth Ave. George W. Biggs was examined last week by attorneys for the creditors. There was nothing developed at the examination.

Among the out-of-town jewelers in the city last week were: H. C. Morrison, Mt. Pleasant, Pa.; E. S. McLeod, Washington, Pa.; E. H. Kennerdell, Tarentum, Pa.; R. L. Kirkpatrick, Butler, Pa.; E. Grieb, Butler, Pa.; E. F. Preiss, Homestead, Pa.; F. F. Robinson, Saltsburg, Pa.; D. L. Cleland, Butler, Pa.; E. H. Schaefer, Beaver Falls, Pa.; Carl Leighner, Butler, Pa.; Harvey Wallace, Smith's Ferry, Pa.; John B. Schafer, Charleroi, Pa.; M. J. Samuels, Youngstown, O.; John Zugschwert, Carnegie, Pa.; W. J. Lowrie, East Palestine, O.; John Linnenbrink, Rochester, Pa.; William Hunt, Uniontown, Pa.; Bert Kurtz, Dawson, Pa.; F. H. Hayes, Washington, Pa.; M. E. Shutterly, New Castle, Pa.; P. C. Yester, McKeesport, Pa.; F. W. Laban, Steubenville, O.

**A CARD.**

Having severed my connection with George W. Dover, whose line I have carried for the past three years, I wish to notify my many friends in the trade that I am now with Thomas W. Lind, the well-known manufacturer of findings at 67 Friendship Street, Providence, R. I. I shall call upon the trade in a few days, with a complete line of findings, settings, galleries, and other trimmings, also for millinery, leather goods manufacturers, etc.

**FRITZ L. KRAUS.**

**Of Greatest Importance**

to the live manufacturing Jeweler is a careful consideration of our lines of Jewelers' Findings.

NEW ASSORTMENTS OF

**Buckles, Galleries, Brooches,  
Settings, Pins, Etc.**

**THOS. W. LIND,**

MANUFACTURER OF JEWELERS' FINDINGS,

67 FRIENDSHIP STREET,

PROVIDENCE, R. I.

THE JEWELERS' CIRCULAR

WESTERN SUPPLEMENT

THE JEWELERS' CIRCULAR

WESTERN SUPPLEMENT

VOL. XXXIX.

NEW YORK, WEDNESDAY, NOVEMBER 22, 1899.

No. 17.

### Chicago Notes.

All communications in reference to the Chicago department of *The Jewelers' Circular*, addressed to Stephen Parlin, 1522 Lill Ave. (Telephone, Lake View 397), Chicago, will receive prompt attention.

W. H. Vogell, of Alired H. Smith & Co., is visiting east.

W. A. Barrows has returned from a business trip to Kansas City and Omaha.

J. C. Leppert, 244 W. Madison St., is convalescent from a severe attack of typhoid fever.

W. J. Miller, Chicago manager for the Seth Thomas Clock Co., has gone to the factory for a few days' visit.

L. A. Lawton, representative of H. M. Quackenbush, Herkimer, N. Y., was here inspecting customers' stocks.

F. P. D'Arcy was here last week buying a stock for his new acquisition, the former John-Larson store, Fond du Lac, Wis.

Henry Klopf, Neillsville, Wis., called on the trade here while on his way to Arizona, where he will spend the Winter.

H. C. Rowbotham, for C. P. Goldsmith & Co., is on a trip in the northwest, and will return to Chicago early in December.

H. D. Fish, Mechanicsville, Ia., who recently bought out H. A. Elson there, added to the stock by purchases here last week.

W. H. Beck, Sioux City, Ia., was in town for a short time, but made no purchases, coming for a family visit to Indiana.

George T. Bynner returned Monday from the east, where he had been visiting the factories for which he is the Chicago representative.

Notices have been sent to creditors of C. W. Rodman, Slater, Mo., of a meeting of creditors, Nov. 25, for the purpose of declaring a dividend of 40 per cent.

Gus Rodenberg, agent for S. & B. Lederer Co., has gone to Mount Clemens, Mich., for treatment for rheumatism, and after a cure will visit his home town, Providence.

Messrs. Reck and Ingalls, the former the financial manager and the latter the silver ware man for L. S. McCabe & Co., Rock Island, Ill., were in town last week making purchases.

Joseph St. Clair was here last week buying stock for a new store at 416 N. 16th St., Omaha, Neb. Mr. St. Clair purchased a good stock of general jewelry and a line of stationery.

Auctioneer J. T. Anderson will shortly

hold an auction at C. S. Bidwell's branch store, Perry, Ia. Mr. Bidwell was here last week buying stock for his main store at Monticello, Ia.

A meeting of the banquet committee of the Chicago Jewelers' Association will not be called for a week or 10 days on account of the absence of Messrs. Sercomb, Fler-shem and Vogell, of the committee.

R. J. Washburn, of R. J. Washburn & Son, Palmyra, Wis., was a caller on the trade last week. F. C. Mayworm, Hancock, Mich., was here buying his holiday stock. L. D. Merrill, Sparta, Wis., bought a good stock in anticipation of a large Fall business.

Frank Blake is a believer in expansion. For 10 years past he had seen its exemplification with the Towle Mfg. Co., one year here and nine at the factory. He passed through last week on his way to Honolulu to take the position of financial manager on a sugar plantation there.

In the matter of E. C. Brand, bankrupt, Dallas, Tex., Mr. Brand has filed a petition for his discharge from bankruptcy, which will be heard Nov. 30. Nothing is known as to the dividend to be paid, but the bankrupt may be discharged and a dividend not declared for a month afterward.

That was a lucky move that Chambers, Inskeep & Co. made a month ago, when they moved their wholesale optical establishment from 146 State St. to 88-90 Wabash Ave. Nov. 16 the quarters from which they had so recently removed were destroyed by fire with a total loss to the dental concern occupying them.

Julius H. Dawes, of Stoughton, Wis., who was arrested by Post Office Inspector Mayer some months ago for using the mails for fraudulent purposes, pleaded guilty before Judge Kohlsaet in the United States District Court Nov. 13 and was fined \$300. He sent out circulars advertising valuable diamonds which could be obtained at a low cost.

G. R. Strickland & Co., New London, Wis., are opening a new store at Fond du Lac, Wis., for which Mr. Strickland was in town buying his opening stock. The new store will be operated as Strickland, Smith & Co. and be under the personal management of Messrs. Strickland and Smith themselves, the latter a Sault Ste. Marie man. Mr. Tulien, of Sault Ste. Marie, has been engaged to manage the New London store.

George Kummer, jeweler, 464 Grand Ave., who buried the bodies of his twin babies in his back yard a few days ago, de-

clares the interment was only intended to be temporary. He states it was his intention to remove the bodies to Elgin, where a relative owns a cemetery burial lot, and that on Nov. 8, before the story was published, he wrote to Elgin in regard to the matter. Mr. Kummer denounces as false the story that his wife did not receive proper medical care.

Manager Loeb, of the Wadsworth Watch Case Co., has taken a financial interest in the Vaughn Metallic Air Brake Hose Co., for the manufacture of metal hose for car connections to replace the rubber hose now in use. It has been approved of and has been in use on a number of roads centering here and is a likely property. Mr. Hooker, formerly a wholesale jeweler, of Des Moines, Ia., is also interested in the company, who have incorporated with a capital stock of \$1,000,000. The hose will be made in Mr. Hooker's factory at Baltimore.

There were a fair number of buyers in town last week, and a number of new stocks were sold. Among the buyers were: G. R. Strickland, of Strickland, Smith & Co., Fond du Lac, Wis.; J. E. Korty, Bluffs, Ill.; A. H. Pollard, Shelbyville, Ill.; William Danor, Fond du Lac, Wis.; R. J. Washburn, Palmyra, Wis.; F. C. Mayworm, Hancock, Mich.; L. D. Merrill, Sparta, Wis.; L. C. Wilson, Crown Point, Ind.; Mr. Freeman, Hoagland, Ia.; E. Munson, Mendota, Ill.; A. B. Conklin, Varna, Ill.; William Morris, Oskaloosa, Ia.; J. H. Gray, Postville, Ia.; A. W. Ford, Freeport, Ill.; A. H. Bollinger, Rockford, Ill.; E. J. Camp, Monmouth, Ill.; D. F. Greene, Fort Wayne, Ind.; J. Van Kammer, Granville, Mich.; C. S. Bidwell, Monticello, Ia.; I. V. Sherman, Cassopolis, Mich.; C. C. Thoma, Battle Creek, Mich.

### Pacific Coast Notes.

J. H. Hoever's jewelry store has been removed to Walnut St., Willow, Cal.

E. M. Bashore, jeweler, Globe, Ariz., is fitting up a side wall case for the display of silver ware.

Fire at Crescent City, Cal., on the 11th inst., destroyed the establishments of Mrs. Elizabeth Stelzer and T. Eausino.

The Utah exhibit of the Paris exposition will include exquisitely tinted onyx tables from the quarry in that State.

The De Friez block, Pasadena, Cal., is being remodeled. Annin & Hall's jewelry and optical store will occupy it upon completion.

**Cincinnati.**

**TRADE CONDITIONS.**

The manufacturers have been busy right along and it seems, as the holiday season advances, the more order work comes in. Most of the firms are working at nights.

Joseph Noterman & Co. have been compelled to work at nights, and all firms are on long time. The demand for diamond work seems to increase as the reports concerning advances still give no hope for a stationary market. Customers are making inquiries and buying more now than they anticipated. Dorst & Co. are busy on Masonic work.

Theodore Neuhaus & Co. are one of the few firms who make a specialty of fine silversmithing, and they are making a name for exquisite workmanship. They have new and most modern machinery and have also most skilled workmen. The firm are busy.

The Bell Watch Case Co. have enough orders for special designs to carry their whole force on till Christmas.

Jos. Mehmert will take up the trip of his salesman who is laid up with illness at Detroit. He goes south this week.

Flat ware will be one of the staple lines this year for holiday presents and some of the leading houses are beginning to show the latest patterns. Oskamp, Nolting & Co. have a fine display.

A. & J. Plaut are moving into their new store near Vine St. on the same side of the street as their old quarters. They will have larger quarters than before and better facilities and conveniences.

Gov. Bushnell has issued a requisition upon the Governor of Indiana for Herman Shrackman, who is wanted in Cincinnati on a charge of stealing a \$50 watch from Duhme Jewelry Co., on June 23,

1899, and who had just been apprehended at Evansville, Ind.

Most of the jobbers will not be able to send out selection packages this year as formerly owing to the large sales made and their depleted stock by the time the holidays approach. So the jewelers who depend largely on these goods for holiday displays will this year be disappointed.

Cincinnati detectives are on the lookout for the professional jewelry thieves who robbed the Sigler Bros. Co. store, Cleveland, as they suspect that the same parties have been lurking in the vicinity of the large stores here. A close watch will be kept for the trio, who are still at large.

A number of retail jewelers were in the city last week buying goods, among them B. J. Dillard, Lebanon, Tenn.; W. B. McAdams, Lawrenceburg, Tenn.; M. Murray, Pulaska, Tenn.; John Zelly, Eaton, O.; J. R. Grove, Bluffton, Ind. They expect a large holiday trade and are preparing for it.

**Columbus, O.**

**TRADE CONDITIONS.**

The jewelers of this city have had a good week, and from all appearances the trade will continue good now until after the holidays. As was predicted in THE CIRCULAR some time ago, they are selling a large amount of high priced goods and a great many costly novelties. This class of business was almost unknown two or three years ago, and the dealers were afraid to buy anything unless they knew it would not go out of style within the next few years, for they had no idea of when they would sell it. Now the case is different, and all the dealers have put in large stocks of the latest styles of everything and they will have little to carry over if the trade continues

as it has been, and, of course, it is only just beginning now.

Mrs. May Baron, wife of Carl Baron, with F. F. Bonnet, died last Tuesday morning at their residence, after a painful illness of more than five months. She was only 25 years of age and leaves a husband and a little son five years of age. The funeral took place at the residence Thursday at 11 o'clock and the remains were interred at the childhood home of the deceased, Reynoldsburg. W. G. Bancroft, Dr. C. C. Benner, Arlington Yauch, E. T. Albert, F. B. Ross and Charles Kahler acted as pallbearers.

**Minneapolis and St. Paul.**

Emil Wirsen has removed from 11 4th St., S. E., to 304 Central Ave., Minneapolis.

F. O. Fiske, of Fiske Bros., Minneapolis, has received a telegram announcing the death of his brother, Elmer Fiske, who was a member of the firm and had been traveling south for his health.

**Cleveland, O.**

Last Monday afternoon Mrs. B. Sands, 24 Sanford St., whose husband is a jeweler on Euclid Ave., lost a chamois bag containing a collection of diamonds and other jewelry valued at \$350. In response to an advertisement the lost bag was returned to Mr. Sands's store at noon, Tuesday. The contents were intact, but one of the rings was badly crushed, some one having stepped upon it.

**Over 100,000 Now in Use.**

**Improved O Size Atlas Movements**

EVERY MOVEMENT  
GUARANTEED.



Nickel Damask.  
Price, \$8.00,  
Catalogue List.

New issue now in NICKEL.  
American manufacture.  
Lever Set Hunting.  
The best American Movement ever  
produced for the money.

**SALE UNPRECEDENTED.**

Write your Jobber for Samples.

EVERY MOVEMENT  
GUARANTEED.



Gilt.  
Price, \$7.50,  
Catalogue List.

**ATLAS WATCH COMPANY,**

9 MAIDEN LANE, NEW YORK.

103 STATE STREET, CHICAGO, ILL.

**St. Louis.**

William Loeffel, Jr., is hunting with a party of friends in the Ozark Mountains.

Wm. Duber has taken a position as watchmaker with Herman Mauch. He was formerly with Jos. Hefner.

Several short term stores have opened and will open in this city shortly. They will carry such lines as Turkish novelties, decorated china ware, etc.

The Western Mercantile Mfg. Co. were incorporated Nov. 11, with a capital stock of \$2,000. They will deal in optical goods. The shareholders are George H. Robinson, Jacob Stumff and Philip Steller.

A new store called Peerless opened on Nov. 20 in the premises formerly occupied by Hess & Culbertson, northeast corner Locust and 6th Sts. It will carry such specialties as silver novelties, bronzes and bric-à-brac.

Among out-of-town members of the trade here last week were: Fred Reed, with I. F. Clark & Co., Big Spring, Tex.; A. Buchroeder, with Gillman & Dorsey, Columbia, Mo.; J. A. Buckmaster, Rolla,

**G. F. WADSWORTH,  
Watch Case Manufacturer  
AND REPAIRER.**

Everything in the line of Watch Case Repairing. Old English and Swiss Cases changed to take American Stem-wind Movements a specialty.

**OLD CASES MADE NEW.  
CHARGES REASONABLE.**

Silversmiths' Building, CHICAGO.

Mo.; W. B. Kern, Bunceton, Mo.; J. W. Acklin, California, Mo.; E. Troutman, Greenville, Ill.; C. E. Randle, Litchfield, Ill.; Arnold Zerweck, De Soto, Mo.

**Kansas City.**

B. C. Bennett's store, Nashville, Kan., was entirely destroyed by fire last week.

C. S. Raymond Sons had a magnificent display of cut glass in their windows last week which made an attractive exhibit.

Burglars broke into the show window of L. J. Marks, jeweler and pawnbroker, 10th and Main Sts., last week, and stole about 40 watch charms and a few chains.

J. H. Wolsieffer, Salina, Kan., proprietor of one of the largest general stores in the west, died last week of heart disease. He was well known among the jewelry salesmen, as he kept a large side line of jewelry.

To make a test of the constitutionality of the department store law William B. Thayer, of Emery-Bird-Thayer Co., submitted to a formal arrest Nov. 15 and later to a fine in the Criminal Court and then took an appeal to the Supreme Court. This proceeding was had as the result of an understanding and agreement between F. C. Farr, the license commissioner, and the attorneys for all the department stores.

The C. J. Wells Co., Utica, N. Y., have been making many improvements in their store, adding very much to its cheerful and beautiful appearance; a handsome new steel ceiling being the more noticeable of them.

**Omaha.**

David Ballmer has opened a jewelry store in Cozad, Neb.

H. A. Borsheim has established a manufacturing and repair shop in the Paxton block.

William Abel, who started in the jewelry business in Petersburg, Neb., last Summer, is erecting a new store building.

Wholesalers of Omaha have some good openings in the west, where they will assist the right man to establish himself.

Carson & Banks, manufacturing jewelers, have secured the services of Andrew Evanson, of Sioux City, Ia., as engraver and diamond setter.

Henry Freund, of Henry Freund & Bro., New York, was in Omaha last week calling on the trade. Norbert Gunzburger, diamond merchant, New York, was in the city Wednesday.

Norman P. Dean, until recently an engraver to the trade, but now giving his exclusive services to Mawhinny & Holliday, was married last week to Miss Sophia Miller, of Hiawatha, Kan.

George Bloom, who recently came to Omaha from New York, and started a jewelry repair shop, has given a chattel mortgage for \$100 on his jewelry tools to Harry Freidman, his landlord.

A. Mandelberg announces that he will hold his Winter opening Dec. 2, when his handsome store room will be decorated with flowers, and the occasion will be enlivened with orchestral music.

The Columbian Optical Co. have added two men to their force. Elwood Riggs, an experienced optician, took charge of the office department early in November. He has been in business in Chicago, and later in Butte, Mon. Edwin H. Reese, of New York, has been secured as an expert in the optical line. He has been with Gall & Lembke and Paul A. Meyrowitz, New York.

Mrs. E. D. Squibb has entered the Omaha Horological School for the purpose of learning optics and engraving, her husband, in the meantime, taking up watchmaking. When they have completed their course they will return to their home, in Bois D'Arc, Mo., and start in business. The horological schools state that the demand for good watchmakers and engravers is greater than it has ever been in Omaha.

A Chicago man got himself interviewed by the reporters of the press last week, and announced that he would establish a mammoth jewelry factory here, employing 600 men. The announcement is causing considerable amusement among the trade. All would welcome such an enterprise, but they look upon the scheme as phantasmagorical. But if a factory cannot be secured, they are hoping for a large wholesale store, which would be a benefit to the smaller jobbers.

**INTERNATIONAL SILVER CO.,**

Successor to

**The Holmes & Edwards Silver Co. AND The Barbour Silver Co.**

MANUFACTURERS OF

**SILVERWARE,**

SPOONS, KNIVES, FORKS, LADLES AND HOLLOW-WARE.

**ST. LOUIS SALESROOMS:**

Holland Building, 209-211-213 North Seventh St.,

ST. LOUIS, MO.

**Georgian STERLING SILVER. In Complete Table Service—**



COFFEE SPOON.

**French Gray Finish.**

**TOWLE MANUFACTURING CO.,**  
CHICAGO. NEWBURYPORT, MASS.



**THEODORE NEUHAUS & CO.,**

Lion Building, 5th and Elm Streets,  
CINCINNATI, OHIO.

SPECIAL WORK TO ORDER.

**Gold and Silver Smiths. MEDALS, BADGES, SCHOOL PINS,**

Repairing and Refinishing Given Special Attention.

All Grades.

The store of Sasek, Prokop & Co., Wilber, Neb., general store with jewelry stock, burned Nov. 12. Loss, \$20,000; insurance, \$12,000.

Rasmer Jensen, jeweler, who recently bought out his employer's stock, has given a chattel mortgage for \$25 upon his tools to A. C. Cumings.

The drug store of H. C. Stokes, Harvard, Neb., who carried a side line of jewelry, burned Nov. 12. Some of the stock was saved. Loss covered by insurance.

Last August Albert Peterson, the janitor in the Paxton block, stole a pair of diamond earrings worth \$350 from A. Mandelberg's jewelry store, which is on the first floor of that building. He confessed his crime and the stolen property was recovered. Nov. 14 his case came up in the District Court, and his attorney brought in evidence that Peterson had not been right in his mind for three years. His case was referred to the insanity board for examination.

Madame Mina L'Aubrey, of Denver, is in the city. Several years ago she was left destitute and started to walk to Cripple Creek. On the way she fainted from fatigue and lack of food. A clergyman who found her by the roadside interested others in her case, and money was raised to send her on to Cripple Creek. There she managed to get into the jewelry business in a small way, and then into "promoting." Her ventures at placing mining stocks were successful, and from a small business she developed a large one. She is now traveling, selling mining stock.

#### Detroit.

Hugh Connolly, who has been ill for several weeks, is at his store again.

The supervisors last week confirmed the contract for clocks for the new county building with the Self-Winding Clock Co.

Foreman A. M. Ward, of the Johnston Optical Co., who was burned about the face while mixing acids for silvering mirrors, has recovered.

The electric clocks all stopped suddenly at the State Capitol building, and a thorough search failed to reveal the cause until Acting Governor Townsend confessed that the ticking of the clock over his folding bed disturbed him and he disconnected the wires.

#### Indianapolis.

##### TRADE CONDITIONS.

Everybody is busy and happy, jobbers filling orders and attending to their trade, retail dealers stocking up and getting into shape for the holiday business, which promises to be very brisk in all lines. So far jobbers have been able to supply all demands for watch movements. Silver novelties are popular.

Out-of-town dealers who came to the city last week to purchase holiday goods included: J. W. Thompson, Danville, Ind.; L. J. Small, Carmel, Ind.; John W. Vest, Greenwood, Ind.; Charles Wolfe, Dana, Ind.; C. E. Arnkens, Frankfort, Ind.; J. W. Hudson, Fortville, Ind.; E. O. Collins, Columbus, Ind.; R. L. Porter, Tipton and Elwood, Ind.; Fred Newhart, North Indianapolis, Ind.; Joseph Booth, Tipton, Ind.

#### An Up-to-Date Jewelry Store.

NOV. 10 marked the seventh anniversary of the establishment in Pueblo, Col., of the store of the Rushmer Jewelry Co. During those years the business has steadily grown, and to-day it occupies one of the handsomest stores in the west. The present location is 319 N. Main St., in the new Pope block, and everything about the store is up-to-date, as are both stock and fixtures. There are displayed just enough cut glass and choice sterling silver to give one an idea of the fine stock inside. In day time the light from the outside is unshadowed by any unnecessary woodwork and at night the light from the top of the window is caught and reflected thousands of times by the sparkling cut glass. The in-

terior arrangement is just about as perfect, and all the woodwork is of natural oak, forming a beautiful contrast with the light colored and frescoed walls and ceiling. The show cases are built on Tennessee marble bases and are of the latest design with curved corners. The tall wall display cases are of the same artistic design and all the cases are but fit receptacles for the fine stock. Along one side of the room is the cut glass. The silver department is just opposite. Both are attractive displays. A large line of diamonds is included in the stock and the holiday goods for the present season are now on exhibition.

To the rear, separated from the store by curtains and ornamental woodwork, is the optical department. John T. Rushmer, a graduate of the Chicago Ophthalmic Col-

## Another Victor.

When the crucial test comes, when quality tells, side by side with the conquerors Olympia and Raleigh stands

## THE BOSTON.



O size, 3 rows of pearls, made in Montauk, 20 years' guarantee, and 14 F.K., 25 years' guarantee.

## Joseph Fahys & Co.,

Established 1857.

FAHYS BUILDING, NEW YORK.

GOLD, SILK AND STONE FOBS,  
 FOB SEALS.

**GEO. O. STREET & SONS,**

24 JOHN ST., NEW YORK.

... Established 1837 ...

TRADE  MARK.

**EMPIRE COMBS. SIDE COMBS.**

GOLD AND JEWELLED ORNAMENTED.

**SPECIALTIES IN ROMAN WORK.**

**DAY, CLARK & CO.,**

MAKERS OF FINE JEWELRY,

23 MAIDEN LANE, N. Y.

**CHATELAIN BAGS. PATENT FRAME.**



STERLING MOUNTED POCKET-  
 BOOKS, CARD CASES, Etc.

**All Fashionable Leathers**

SPECIAL HOLIDAY LINES.



**C. F. RUMPP & SONS,**

FINE LEATHER GOODS,

Fifth and Cherry Streets, - Philadelphia.

New York Salesroom: 621 Broadway.



**Eliassof Bros. & Co.,**

IMPORTERS AND JOBBERS OF

**DIAMONDS, WATCHES, JEWELRY,**

9-11-13 Maiden Lane,

NEW YORK.

Materials, Tools and Optical Goods.

ALBANY OFFICE: 62 & 64 STATE STREET.

**ALOIS KOHN & CO.,** SOLID GOLD CHAINS,  
 4 MAIDEN LANE, Near Broadway, N. Y.

We call the attention of the Trade throughout the country to our line of

**LORNETTE AND GUARD CHAINS.**

Will send Samples on Memorandum on receipt of satisfactory reference. Correspondence Solicited.

**WM. SMITH & CO.,** GILL BLDG., 9-13 MAIDEN LANE, N. Y.  
 61 PECK ST., PROVIDENCE, R. I.

ESTABLISHED  
 1854

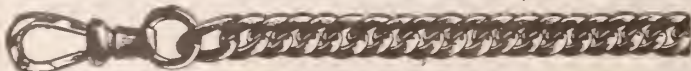

MANUFACTURERS  
 OF

**Gold, Silver and Rolled Plate Chains and Jewelry.**

Novelties in Gold and Silver Bracelets. Also a large line of Chain Trimmings.

lege, is in charge of that department. James Hopkins has charge of the watch repairing department in the front of the store. The lens grinding and the engraving are done just over the optical department. Gorton Rushmer, the general manager of the store, has been in the jewelry business for 25 years. He personally buys all the stock and his good judgment and artistic taste are evident in every article in the stock. The local papers gave admiring notices of the anniversary of this house.

**Connecticut.**

C. H. Tibbits, Wallingford, has contracted for the erection of a fine residence for himself.

The Bridgeport Electric Co., Bridgeport, will soon open a silver plating shop at 166 John St., under the management of A. Robinson.

R. S. Gardner, Derby, is ill and on Thursday his condition had become critical. Acute Bright's disease is developing from the severity of the fever poisoning, and a consultation of physicians was held Thursday afternoon.

A new brick boiler house, 40x25, is being built for the International Silver Co., on S. George St., Meriden, to be used by the Barbour Silver Co. when they move into the factory formerly occupied by the Meriden Silver Plate Co., about Jan. 1.

The Middletown Silver Co., Middletown, started work at their factory Thursday morning with a small force of men. They will increase their force as the trade demands it. They will have out in about 10 days a line of silver plated ware.

A fire broke out in Pillard's bicycle shop, Main St., New Britain, Nov. 18. The shop is in the old Lewis, Wessel & Leward jewelry factory. The department responded promptly and the blaze was extinguished in a short time. An overheated stove in the repair shop is blamed for the blaze. The front part of the building is occupied by Porter & Dyson, jewelers, and Edward W. Riecker, who sleeps in their office, didn't know there was a fire until he heard the noise on the outside.

**Worcester, Mass.**

Frederick Hermann Lucke, son of Hermann Lucke, jeweler, 281 Main St., was married Nov. 14, to Miss Grace Eustes Whitten, daughter of Mrs. H. W. E. Whitten, the ceremony taking place at the home of the bride.

S. B. Husselman, president of the Worcester Optical Co., is interested in the incorporation of the American Tropical Planting Co., soon to be incorporated under the laws of Delaware, with a capital stock of \$1,000,000.

Nathan B. Fisk, for one year a resident of Worcester, died Wednesday at the home of his daughter, Miss Ella Fisk, 3 Davis St., from heart disease, death being sudden. He was born in North Scituate, R. I., 77 years ago, and had lived in Uxbridge and Miliord for a long time, working at the trade of jeweler. His body was taken to Uxbridge Saturday for burial, services being conducted by the Uxbridge Grand Army Post, of which he was a member.

**Dividend to Creditors of the E. Howard Watch & Clock Co.**

BOSTON, Mass., Nov. 18.—It is announced that the creditors of the E. Howard Watch & Clock Co. have received a first payment of 20 per cent on their claims. It will be remembered that the company, together with president Samuel Little and treasurer Arthur M. Little, made an assignment in April, 1898. Various attempts have been made since that time to dispose of the plant by the trustees, Carpenter & Snow, and a syndicate of which President Little was the head held an option on the property several weeks prior to Oct. 15, when it expired without action on their part.

The liabilities are several hundred thousand dollars, but it is anticipated that eventually creditors will realize 75 per cent or more of the indebtedness.

**Movement to Consolidate the Manufacturers of Cameras.**

CHICAGO, Ill., Nov. 18.—A movement having for its object the consolidation of all the camera manufactories is being quietly made, and already, it is said, options have been secured from nearly all the manufacturers in Chicago. Projectors of the proposed combination say that enough signatures already have been secured to assure success. The movement already has had the effect here of a radical reduction in prices of both plate and film cameras, one big eastern firm outside the combination, and manufacturing film cameras, leading in the war of prices. A movement is also said to be on foot for the combination of all the plate manufacturers into a trust. In this movement, as in that of the proposed camera trust, one big eastern concern has refused to accede to the terms of the trust organizers, and the movement may fall through.

**Death of an Old Clock Case Maker.**

BRISTOL, Conn., Nov. 17.—William Day, one of the oldest persons in town, died Tuesday night after a short illness from whooping cough. He was almost 91 years of age. He was born in Lanesboro, Mass., March 28, 1809, and was educated in the common schools of his native place until he was 15 years of age, when he went to Pittsfield, Mass., to learn the trade of a cabinet maker. He remained there until he was 21, when he came to Connecticut and went to work for the first Seth Thomas in Plymouth Hollow (now Thomaston), making clock cases. This business he followed during the remaining years of his active life. After leaving Plymouth Hollow he lived in Unionville, Farmington and Southington, and in 1841 came to Bristol to enter the employ of Ray & Carpenter, clock makers. This firm were succeeded by Ray & Ingraham, and their successors were Brewster & Ingraham, who were succeeded by E. Ingraham & Co., the E. Ingraham of that time being Elias Ingraham, the grandfather of the present Ingraham, the clock maker. He remained with the latter concern until 1880, when he retired from active work. He represented Bristol in the Legislature of 1854.

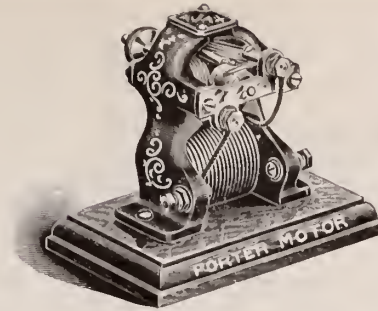

**K. & D.**  
**Staking Tools**  
**AND**  
**BATTERY MOTORS.**



**WATCHMAKERS TOOLS.**



**KENDRICK & DAVIS, + LEBANON, N. H.**

**American Tools are the Cheapest**

Because they are the Best  
and Parts can always be duplicated quickly.

**FOR SALE BY ALL JOBBERS.**

**SEND FOR OUR NEW ILLUSTRATED CATALOGUE.**

**EBONY GOODS.**

Before placing your orders for import do not fail to see our line. We can save you money. A postal card will insure a call from our representative with samples.

**SELWYN IMPORTING & TRADING CO.,**

14 East 17th Street, New York.

**BONNER & CO.,**

Manufacturers of

**FINE DIAMOND MOUNTINGS,**

57 MAIDEN LANE, NEW YORK.

Established 1879.

Manufacturer of

**LOUIS W. HRABA, Fine Leather Goods**

29 East 19th St., New York.

Exclusively for the Jewelry Trade.



SAMPLE OF ENGRAVING DONE ON THE

**Eaton-Engle Engraving Machine.**

CATALOGUE AND SAMPLE OF WORK FREE.

**EATON & GLOVER** have removed to the FULTON BUILDING, 87 NASSAU ST., Cor. Fulton, N. Y.



**ESSER & BARRY,**

Largest Manufacturers of

Cheap and Medium Priced

**IMITATION DIAMOND JEWELRY**

IN AMERICA.

Write us for samples of almost anything with an Imitation Diamond in it.

MAIN OFFICE AND FACTORY, 101 SABIN ST., PROVIDENCE, R. I.

### News Gleanings.

Daniel Van Alst has opened a jewelry store in Montgomery, N. Y.

J. Frank Starbuck will re-locate in the jewelry business in Marion, Ia.

Sydney Diamond has established himself as a watchmaker in Tallahassee, Fla.

W. B. Godfrey has purchased the jewelry stock of C. S. Graves, Bay City, Mich.

The National Watch & Clock Concern, Richmond, Ind., has removed to 1030 Main St.

W. J. Shiffler and B. F. Gorsuch will open a jewelry store at Williamsburg, Pa., soon.

John D. Pease will open a jewelry department at Reed & Bennett's store, Barker, N. Y.

Mr. Richards has opened a jewelry store in the Seeburger block, North Des Moines, Ia.

Ali Hallberg has closed his repair shop in Belt, Mon., and removed to Great Falls, Mon.

The new jewelry house of Simon Bros., 325 Austin St., Waco, Tex., has been opened.

J. W. Forney, Steubenville, O., has been appointed official watch inspector for the W. & L. E. railway.

James Doughty, Bridgeton, N. J., has closed his restaurant and will start afresh in the jewelry business.

F. W. Laban, formerly of Toronto, O., is now thoroughly established in his new store in Steubenville, O.

M. L. Vial, Weiser, Idaho, is now located in his handsome new brick store across the street from the old stand.

D. G. Lowe, who has been in the jewelry business in East Tawas, Mich., for 20 years, has closed out his business.

In a fire in Hartford City, Ind., that destroyed several business houses, the store of C. L. Casterline, jeweler, suffered.

H. C. Morrison, Mt. Pleasant, Pa., has moved his jewelry store into the Farmers' and Merchants' National Bank block.

Weichel, jeweler, Scranton, Pa., announces that he is going out of business Jan. 1, and is running an auction sale.

Ira Bullard has purchased the watch repairing outfit of Charles Enkoff, Montgomery, Ind., and will continue at the old stand.

Bert Carey, Montrose, Mich., has enlarged his quarters and added a line of lamps and fancy crockery to his jewelry stock.

In a fire in Saranac, Mich., a few days ago E. A. Anderson's jewelry stock and building suffered to the extent of \$1,000; no insurance.

The Buffalo (N. Y.) Review of Nov. 13 contained complimentary notices of the jewelry stores of E. E. Muller, Austin Prescott and C. C. Bradley & Co., Batavia, N. Y.

Bachner Timepiece Co., Princeton, Ind., have incorporated for the manufacture of timepieces, motors, etc. Capital, \$100,000. Incorporators: J. Bachner, of Chicago, Ill.; S. T. Gilman, H. E. Lewis, W. H. Lewis, J. A. Oswald, all of Princeton.

Sun Optical Mfg. Co., with principal of-

fice at 8 N. Warren St., Trenton, N. J., have been incorporated to manufacture optical goods. Capital, \$50,000. Incorporators: George F. Applegate, Freeman C. Leaming, Paul Lupke, all of Trenton, N. J.

Treasurer L. C. Lane, of the Watch Factory Relief, of Waltham, Mass., makes the following report for the month of October: Received for dues, \$340; paid out in sick and death benefits, \$556; making \$216 more paid out than received.

On the night of Nov. 12 a thief entered the drug store of Dr. H. C. Hudson, Kenton, Tenn. F. W. Bice, jeweler, who has one window of the store for his jewelry department, lost several watches, tools, etc. The thief evidently knew the store well.

Henry G. Meyer has resigned his position as assistant cashier of the Citizens' Savings bank, Meridian, Miss., to engage in the jewelry business with the firm of Meyer & Schamber, retaining his interests in the bank and his membership on the directory board.

J. V. Alfried & Co., stationers and jewelers, 190 Main St., Norfolk, Va., have recently put on a new dress both inside and outside their new store, which now presents a most attractive appearance. The firm make a fine display of C. Dorflinger & Sons' cut glass.

E. G. Clark, vice-president of the Ontario Silver Co., Muncie, Ind., reports the past year's business of the company very successful. The company established themselves in Muncie three years ago. They operate a similar plant in Humberstone, Ontario.

A. A. Roy, jeweler, East Hampton, N. Y., has purchased property, 151x25 feet, and store building, which he has occupied since November, 1896. Jeweler Roy went to East Hampton three years ago, and has now established his store upon a basis which has placed him among the permanent business men of the village.

The trial of Albert Knispel, alias McLane, on a charge of stealing some watches from the jewelry repair shop of S. A. Tipton, 938 P St., Lincoln, Neb., took place a few days ago. The boy had confessed his guilt and had aided the officers in recovering the stolen property, so the Judge did not care to be very hard on him. He was fined \$100 and costs and was committed to the county jail.

Penrose Myers, jeweler, Gettysburg, Pa., at the last election was elected county treasurer of Adams county for three years, by a majority of 581. The Democratic majority of the county is 300, so Mr. Myers ran away ahead of his ticket. The town of Gettysburg was 195 Republican majority, but Mr. Myers carried it by 167 Democratic majority, the Republican candidate also residing in that city. Mr. Myers will take his office Jan. 1, 1900. The Littlestown Jeffersonian, commenting on the election, said: "Penrose Myers is profoundly thankful to the public for their most emphatic endorsement of his candidacy for county treasurer. They believed that he needed it; he recognizes that only the highest standard of excellence in the administration of the county treasurer's office can suffice as repayment for the voters' kind consideration of his candidacy."

## SUSSFELD, LORSCH & CO.



Ask your jobber for  
our lines of Optical  
Goods.

### Reading Glasses

in

**Pearl and Gilt**

as well as with

**Black Handles**

AND NICKEL MOUNTED.

### Opera Glasses

in latest styles.

37 & 39 MAIDEN LANE,  
NEW YORK.



Jas. P. Butler has opened a repair shop in Greenville, Miss.

A. W. Sower has sold out his jewelry business in Van Buren, Ark.

J. C. Kelley has discontinued his jewelry business in Big Timber, Mon.

A judgment for \$180 has been rendered against A. E. Colburn, Argenta, Ark.

Joseph W. Field, Galveston, Tex., has been sued for taxes amounting to \$354.

Oscar E. De Worthen, Columbia, Mo., has given a realty trust deed for \$6,000.

Wm. A. Ingalls, South Bend, Wash., has given a chattel mortgage for \$300.

M. L. Pershall, Spokane, Wash., has paid off a chattel mortgage amounting to \$420.

Jake Hilderbrand has given a bill of sale on his watchmaking business in Alexander, Ia.

James Nabb has removed his optical parlors from El Paso, Tex., to Albuquerque, N. M.

F. W. Seidl, Manitowoc, Wis., is contemplating extensive improvements at his store.

An auction sale has been advertised of the jewelry stock of P. H. Ramsour, Tyler, Tex.

A. E. Sipe, Buffalo, N. Y., has returned from a business trip to New York and Providence.

A. D. Ralph, optician and jeweler, has opened a store in room No. 4, Allen block, Cherryfield, Me.

W. S. Shuttles & Son, wholesale jewelers, of Dallas, Tex., have been sued on a debt amounting to \$6,000.

K. E. Knowles, of the Wilkinson Jewelry Co., Denison, Tex., together with others, has been sued for \$248.

Sam Sterchi, Terre Haute, Ind., who has been sick for some time, was removed to St. Anthony's Hospital last week.

George J. Haffa, Buffalo, N. Y., last week filed a petition in bankruptcy. The liabilities are \$720.20; assets nothing.

A. F. Smith, who has been with M. T. Torsen, Decorah, Ia., for two or three years past, will open a jewelry store in Waucoma, Ia.

E. L. McDowell, Arkansas City, Kan., has just returned to his home after spending a vacation visiting the eastern cities, accompanied by his family.

A. Aron, Springfield, O., who had a limb amputated recently, was removed from the hospital to his home last week, having partially recovered after the operation.

Ottawa Silver Co., Ottawa, Ill., have incorporated with a capital stock of \$45,000 for the manufacturing of and dealing in solid and plated wares. Incorporators: Samuel D. Wead, George T. Page, David Ross.

J. C. Johnson, Mt. Sterling, Ill., has sold his fixtures to Hoettchen & Wolff, of Astoria, who will open a first class jewelry store in the room vacated by him. Mr. Hoettchen is an optician while Mr. Wolff is a jeweler.

E. H. Hopkins, Palmer, Mass., has gone to Hartford, Conn., to take a position with the firm of A. L. Foster & Co. The firm are putting in a line of watches and clocks, and Mr. Hopkins will have charge of the new department.

# THE LADY RACINE

IS THE

## Best Chatelaine Watch

10 Line,  
11 Line,  
12 Line,  
13 Line,  
Hunting or  
Open Face,



Nickel,  
Steel,  
Silver,  
Enameled,  
Gold,

In new and tasty designs.

Can be ordered from all Reliable Jobbers.



## Our New...

# Jewel Case



has been pronounced by competent judges the best in size, shape, workmanship and fitting, in the market.

### Roy Watch Case Co.,

Makers of SOLID GOLD CASES,

21 Maiden Lane, New York.



TRADE-MARK REGISTERED.

W. B. Waggoner, of Columbus, O., was in Muskegon, Mich., last week, the guest of his brother, E. G. Waggoner, inventor of the Waggoner watchman's clock. Until very recently W. B. Waggoner has been chief clerk of the mechanical department of the Pennsylvania railroad at Columbus, but resigned to go to Muskegon and take the management of the Waggoner Watchman's Clock Co. Mr. Waggoner has secured offices in the William Alden Smith building, S. Ionia St., Grand Rapids, and will open up headquarters there. The clocks will continue to be manufactured in Muskegon.

#### Clock Manufacturing in Japan.

[From Tokyo, Japan, *Commercial Journal*, July.]  
**O**UR wall clocks which had had once a considerable market in Vladivostock, China and Korea, have lost all the patronage in those places, owing to dishonest practices on the part of some unscrupulous manufacturers of Nagoya, some time last year, the unfortunate event itself being largely an outcome of a very keen competition among the increasing number of manufacturers, which naturally had brought down the prices to a very low level. Under the circumstances, a proposal was re-

cently started among the manufacturers at Nagoya and vicinity to effect a trust of the trade. Some days ago two representatives of Nagoya manufacturers came up to Tokyo to induce their metropolitan confreres to endorse the trust scheme. The Tokyo Tokei Seizo Kwaisha (Tokyo Clock Factory), the Seikosha and some other establishments of Tokyo, are reported so far to have expressed themselves in favor of the project, a sentiment shared by most of the Osaka manufacturers also. In consequence a conference regarding the formal organization of the trust is expected to take place at Nagoya at an early date, to be attended by the representatives of all the principal manufacturers in the country. We learn that the draft resolutions for discussion on the occasion will be drawn by the officers of the Tokyo Clock Factory.

#### The Rage for Gems.

[New York *World*, Nov. 12.]

**N**EVER before in the history of our country was there such a rage for jewels as now. Never before, indeed, were such magnificent displays of gems possible on this side of the Atlantic.

While America was poor and undeveloped the habits of her people were simple. Now, in an age of record breaking fortunes, with a society made up of multimillionaires, she puts to shame the luxury of the Orient.

Here are a few of the startling facts that prove it:

On the day of their wedding George Vanderbilt clasped a necklace of rubies about the throat of his bride. Its value is \$100,000. It cannot be duplicated anywhere on this planet.

Its great feature is the series of five perfectly matched pigeon-blood rubies, of wonderful size and beauty, in the upper strand. These stones are valued at \$80,000. The diamonds used for the loops and pendants are worth \$20,000.

Another bride, only a few years ago, Mrs. Oliver Iselin, had more jewels among her wedding presents than any rajah of India ever dreamed of.

Mrs. Bradley-Martin has a tiara of thirty-six points valued at a quarter of a million. Besides this she has "a few quarts"—not to say pecks—of other jewels, among them a splendid diamond and sapphire necklace.

Mrs. Hicks-Lord, whose jewel casket is regarded as of very moderate dimensions, has five diamond necklaces, one of which is valued at \$250,000. It is one of the finest in the world, being made up of flawless stones exquisitely matched.

The late Mrs. John Jacob Astor once wore a panoply of jewels of such surpassing and perilous value that she was not only guarded by private detectives, but accompanied by 10 mounted policemen on her way to and from the ball. Her gems were then accounted the most costly in America.

It is estimated that the jewels belonging to the Vanderbilt family alone aggregate in value at least \$3,000,000. The collection includes most of the gems with which the Empress Eugenie once dazzled Paris.

Even in luxury and extravagance the East must yield. America still leads.

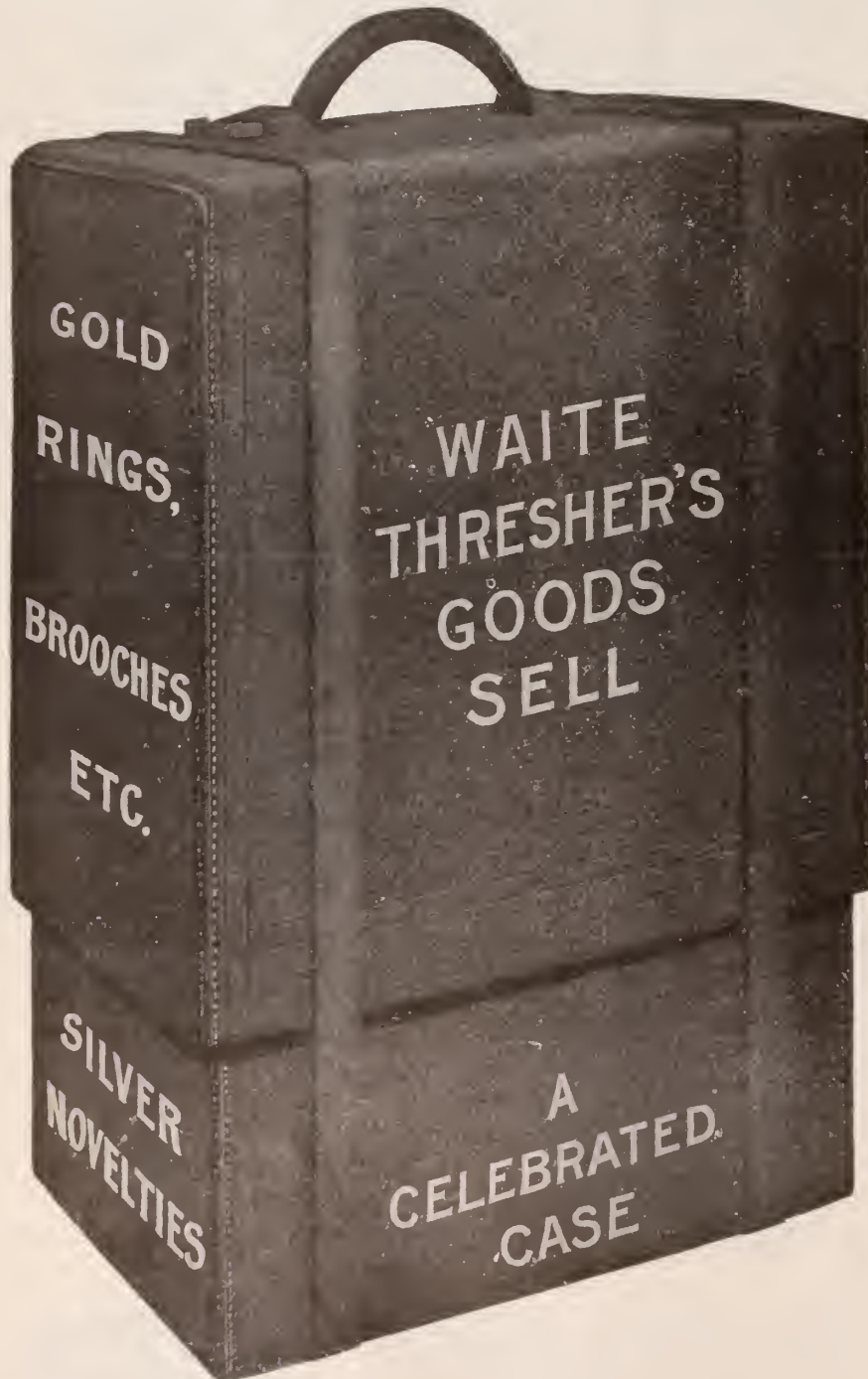

Remember that Articles Purchased from Samples Shown from the Above Celebrated Case are Quick Sellers at Popular Prices.

NEW YORK OFFICE, 11 John Street.

**NONE BETTER.**

# THE "L" SOLDER

Recommended by Manufacturers and Repairers.

Our Solders are not plated, but the natural color of the stock.  
Gold Solder in 1 dwt. pieces. Silver Solder in ¼-oz. sheets.

Sold in bulk or in any thickness or width desired.  
In Low Karat—6, 8, 10, 14 and 20.

**ASK YOUR JOBBER FOR IT.**

If he does not carry it, write us.

PRICES ON APPLICATION.

MANUFACTURED  
...BY...

**THE LEDOS MFG. CO.,**

32-34 Pearl St., Newark, N. J., U. S. A.

American  
Watch Case Co.,

**A.W.C.CO**

9-11-13 Maiden Lane,

Gill Building. New York.

**TO BLOW EFFECTIVELY IS AN ART**

which we never practice personally; but we have invented a machine which does it for us, called the

"Reichhelm Pressure Blower."

This, with Gas Furnaces and Jewelers' Tools generally, is the stock in trade of

E. P. REICHELHM & CO.,  
23 JOHN STREET, NEW YORK CITY.



**SIMONS BROS AND CO**  
PHILA. NEW YORK CHICAGO  
SILVERSMITHS, JEWELERS.  
MAKERS OF GOLD AND SILVER THIMBLES.

"By Using Our Goods Your Goods Will Sell."

# We Always Lead

With Something New and Artistic for Manufacturing Jewelers.

**OUR FINDINGS SPEAK FOR THEMSELVES**

Call or Send for Samples of

# OUR LATEST

**And Keep Your Trade Guessing What You Will Show Them Next.**

We are now showing a handsome and complete line of

**MEDALLIONS AND EBONY MOUNTS.**

# HEIMBERGER & LIND,

158 PINE ST., METCALF BUILDING, PROVIDENCE, R. I.

# JULES JÜRGENSEN,

COPENHAGEN,

Plain and Complicated **WATCHES AND CHRONOMETERS,**

Are the leading production of their kind in the world.

SOLE AGENTS

# Schulz & Rudolph,

Importers and Cutters of Diamonds and Other Precious Stones.....

28 JOHN and 65 NASSAU ST., NEW YORK.

# AIKIN, LAMBERT & CO.,

MANUFACTURERS OF

FINE GOLD PENS, HOLDERS, PENCILS,  
TOOTH PICKS and NOVELTIES.

PAUL E. WIRT FOUNTAIN PENS, at new and lower prices . . .  
MERCANTILE FOUNTAIN PENS, guaranteed to give satisfaction.

Catalogues with terms and discounts furnished to the trade.

BRANCH, 103 STATE STREET, - - - CHICAGO.

# AIKIN-LAMBERT JEWELRY CO.,

IMPORTERS OF

# DIAMONDS.

JOBBERS IN

**WATCHES, JEWELRY, CHAINS,  
NOVELTIES, ETC.**

LATEST DESIGNS.

LOWEST PRICES.

**19 MAIDEN LANE, NEW YORK.**

**The Latest Patents.**

ISSUE OF NOV. 14, 1899.

**636,811. CASE FOR EYEGLASSES OR SPECTACLES.** HENRY E. KIRSTEIN, Rochester, N. Y. Filed July 14, 1899. Serial No. 723,844. (No model.)

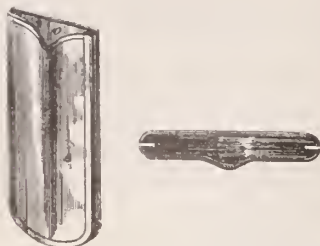

A collapsible case for eyeglasses and spectacles open at one edge consisting of the two stiff side pieces, one of them having the inwardly-turned flange at the edge, and flexible connections between three of the edges of the side pieces.

**636,960. BUTTON.** GEORGE W. DOVER, Cranston, R. I. Filed Aug. 29, 1899. Serial No. 723,923. (No model.)



A button comprising a tapering post, two concavo-convex plates with their convex surfaces outermost each secured to the post, and a third plate extending over the upper of said plates constituting a face plate.

**637,179. SECONDARY ELECTRIC CLOCK.** JAMES J. STOCKALL, SR., London, England. Filed Sept. 12, 1899. Serial No. 730,267. (No model.)

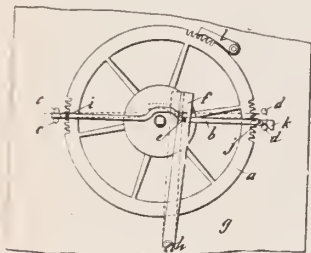

In apparatus for effecting a step-by-step rotary motion, the combination with a toothed wheel to

which a step-by-step rotary motion is to be imparted, of an arm receiving a to-and-fro motion from any suitable power and two pallets actuated by such arm so as to be alternately engaged with opposite sides of said wheel so that the one pallet which only has a to-and-fro motion radially of the said wheel comes into engagement therewith before the other pallet which receives both a radial to-and-fro motion and a circumferential motion is brought out of engagement.

**637,032. RETINOSCOPE.** SETH A. RHODES, Chicago, Ill., assignor to the Geneva Optical Company, same place. Filed Aug. 9, 1899. Serial No. 726,638. (No model.)

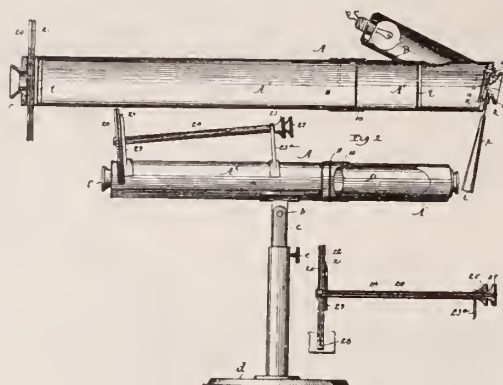

In retinoscopes, the combination with the stationary section of the focal tube having cross slot on its upper side, of the rotatable section of said tube having the light tube projected at an angle therefrom, the tilting mirror extending across such rotatable section and the transverse disk with plural lenses therein, said disk being mounted within said cross slot and permanently above the stationary section of the focal tube free from contact with the patient's face.

**637,189. COLLAR BUTTON.** WILLIAM O. WHEELER, Sharon, Conn. Filed Aug. 1, 1899. Serial No. 725,792. (No model.)

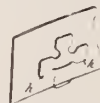

A collar button composed of thin material substantially as described, having the vertical wings adapted to enter the horizontal buttonholes in the collar and neckband and lateral wings extending beyond the ends of the buttonholes in the buttonhole of the collar.

**637,199. EYEGLASSES.** HARRY FENNELL, Everett, Mass., assignor of one-half to Arthur A. Gleason, same place. Filed Aug. 8, 1899. Serial No. 726,556. (No model.)



The combination with a lens, a setting or clasp for the same provided with forks or arms which embrace said lens, a screw extended through said forks or arms and said lens, and provided with an angular portion below its head, of a locking device having an angular opening through which said angular portion of the screw extends and provided with fingers to engage the setting.

**DESIGN 31,817. WATCH STAND FOR TOILET TABLES.** SADIE W. RAY, Annapolis, Md. Filed Oct. 16, 1899. Serial No. 733,832. Term of patent 3 1/2 years.

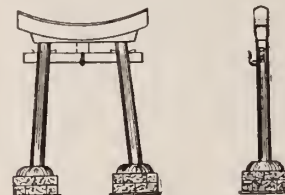

**EXPIRED PATENTS.**

[Recently expired patents of interest to the jewelry trade. Reported specially for THE JEWELERS' CIRCULAR by R. W. Bishop, Patent Attorney, 728 Fifth St., N. E., Washington, D. C., who will furnish complete copies of patents at the rate of 10 cents each.]

Issued Nov. 21, 1882.

**267,782. BRACELET.** ALEX. ENGELMANN, North Attleboro, Mass.

**267,824. WATCH HANDS.** J. W. BELL, Conowingo, Md.

**267,851. BRACELET.** ALEX. ENGELMANN, North Attleboro, Mass.

**267,886. BRACELET.** J. C. HARRINGTON, Providence, R. I.

**267,970. LEAD OR CRAYON HOLDER.** F. W. BROOKS, New York, N. Y., assignor of one-fourth to W. C. McIntire, Washington, D. C.

**267,976. SLEEVE BUTTON.** WALLACE DURAND, Newark, N. J., assignor to Durand & Co., same place.

Designs issued Nov 22, 1892, for 7 years.

**22,000. THIMBLE.** F. G. CRABB, New Haven, Conn.

**22,011. CLOCK CASE.** ARTHUR MERRITT and E. F. AUCAIGNE, New York, N. Y.

Design issued Nov. 19, 1896, for 3 1-2 years.

**25,501. WATCH CHAIN.** F. W. WOOD, Indianapolis, Ind.

W. P. Reichert, Canton, Ill., will occupy a remodeled store.

Noble's jewelry store, Guthrie, Ky., was burned out Nov. 13.

**PATEK, PHILIPPE & CO., GENEVA, SWITZERLAND,**

MAKERS IN THE HIGHEST QUALITY OF

**Fine, Plain, Complicated And Decorated Watches**

IN 15 DIFFERENT SIZES.

NEW YORK OFFICE, 68 NASSAU ST.

INTERCHANGEABLE PARTS.

ALFRED G. STEIN, Representative.

**THE TRUE BLUE**

Beaded Label Watch Glasses,

MADE IN

**FRANCE.**

ASK YOUR JOBBER FOR THEM.

**SUSSFELD, LORSCH & CO.,**

21 Rue de L'Echiquier, PARIS.

LORSCH BUILDING,

37 & 39 Maiden Lane, NEW YORK.



**WATCH GLASSES**

BEAR THE BEADED LABEL.

BEWARE OF IMITATIONS.

THE GENUINE ARE LABELED



**FRANCE.**



## PRACTICAL COURSE IN ADJUSTING.

### COMPRISING

*a review of the laws governing the motion of the balance and balance spring in watches and chronometers, and application of the principles deduced therefrom in the correction of variations of rate arising from want of isochronism, change of position and variation of temperature.*

### ELUCIDATED AND DEMONSTRATED BY

*original experimental researches in the actual problem, never before published, showing the causes that are operative in the variation of rate and leading to correct remedies.*

BY THEO. GRIBI.

Copyright by Theo. Gribi; assigned to THE JEWELERS' CIRCULAR PUB. CO.

[COMMENCED IN ISSUE OF FEB. 1, 1899. PART XXI.]

## CHAPTER IV.

### APPLICATION OF CORRECT PRINCIPLE IN THE CONSTRUCTION OF WATCHES AND PRACTICAL WORK OF ADJUSTING.

**17. Mechanical Defects.**—Before proceeding any further we must now turn our attention to the consideration of disturbances which have their origin in mechanical defects; for they must be remedied ere we can expect good results. The principal ones which the repairer meets with are in the escapement.<sup>10</sup>

In the first place the escapement must be "in beat"—*i. e.*, the interval between two successive beats must be of equal duration. This is the case when, with the balance at rest, the jewel pin stands on the line of centers between pallet arbor and balance. We have already discussed (4, c) the unlocking and impulse in the lever escapement. These factors are unavoidable, but their effect can be reduced to a minimum by adherence to correct principles in the construction of the escapement. It is very plain, for instance, that, when the locking angle is too great the disturbing influence resulting from the unlocking is increased. In properly made escapements with steel wheels,  $1\frac{1}{2}^\circ$  is sufficient, and  $2^\circ$  should be the maximum. The smallness of the locking angle permissible depends upon the fidelity with which the wheel and anchor are executed. If the wheel is perfectly true and round and reduced to a minimum weight, and the lifting stones of the proper width, the minimum of locking angle can always be obtained.

Another defect frequently met with which needlessly increases the resistance of the unlocking is too much passage way, or lost motion, of the lever after the tooth has fallen off the lifting stone. There should be just

enough to insure the passage of the highest tooth, and that requires very little. In many watches, particularly factory-made ones, we find the impulse table too large, both as to the safety action and the distance of the jewel, or impulse pin, from the center. This invariably necessitates lost lever motion.

Again, too great a draw angle on one or the other, or both, of the lifting stones will increase the resistance to the unlocking. In many of the American watches the slots in the steel frame for the reception of the lifting stones are cut too wide, and the setting of them at the proper angle depends upon the cementing in. This leaves the draw open to the chances of variation. While too much draw angle increases the resistance to the unlocking, on the other hand too little of it makes the locking unsafe, particularly on the entering stone, where the action of the wheel is of the nature of a push, as distinguished from that on the exit stone, where it is a real draw. The latter defect may prove fatal, particularly when the lever is not in poise, or too much out of poise, in consequence of which the fork may fall back, after banking, in some one or the other of the vertical positions, and the guard touch the impulse table. This defect is the more serious, as it is difficult to detect it in the act, and may manifest itself only during the carrying of the watch.

One of the principal conditions to be observed is the proper freedom of the jewel pin in its passage in and out of the fork during the action of the escapement. When the passage way of the fork from one banking to the other has been limited to the least possible to insure safe escapement, the jewel pin, when in the act of passing out of the fork and while standing in front of the outer corner of the slot should have just enough clearance to pass without touching the corner in any of the positions the watch may be placed in. There should be a little play between the corner and the flattened front of the jewel pin when the fork rests against the banking. It is difficult to say just how much, but one degree motion of the fork would be a safe quantity. It should be the least possible, taking into consideration the side shake of the pivots. Too much play, on the other hand, the passage way of the fork being limited to the proper extent, would result in diminished impulse communicated to the balance, which is also to be avoided.

The weight of the escape wheel, as well as of the fork and pallets, is of vital consideration in a watch, the adjustment of which is to be attempted. Keeping in view the desideratum of getting the greatest motion of the balance with the least motive power, and not forgetting that the latter, at the circumference of the escape wheel, is reduced to an infinitesimal quantity, reason dictates that these organs, more than any other in the watch, should be the lightest possible consistent with proper firmness. All unnecessary weight in them increases the general resultant of defects in the escapement. For this

(10) The reader should familiarize himself with the principles of the lever escapement by consulting Grossman's "Lever Escapement;" Mr. C. Saunier's works, both translated into English, or the various treatises on the subject published by the Journal Suisse d'Horlogerie, Geneva, Switzerland.

reason a scape-wheel made of steel, which can be made hard and thin, is preferable to one of brass, and much preferable to one made of gold. The lighter escape wheel, fork and pallets are, the prompter and surer will their function be. A heavy escape wheel, moreover, directly increases the inequality of the impulse before and after the line of centers (4. c); for, owing to the draw on the locking surface of the lifting stones, there necessarily results a certain amount of recoil of the wheel during the arc of unlocking of the balance. As this takes place when the latter has acquired its greatest

velocity, it throws the wheel back a little further than necessary, so that the tooth does not immediately slide on to the driving plane of the lifting stone on reaching the locking corner, but by reason of its sluggishness lags behind and may reach the plane only when the fork has reached nearly the line of centers, thus diminishing still more the impulse communicated before the balance spring reaches its state of rest. No very close adjustment can ever be obtained in watches with heavy escape wheel, fork and pallets.

(To be continued.)

### Setting the Seconds Hand in Pocket Watches.

(Translated from the *Annales de l'Alliance Scientifique*.)

THE stem-winder of portable watches does not allow of setting to time the hand on the seconds dial, so that very often the owner of a seconds watch does not know the time except within about a minute. A Paris watchmaker, Mr. Nitzel, has contrived a mechanism for adjusting the second without changing in any respect the exterior arrangement of watches. This apparatus has been attached for the first time to a chronometer belong-

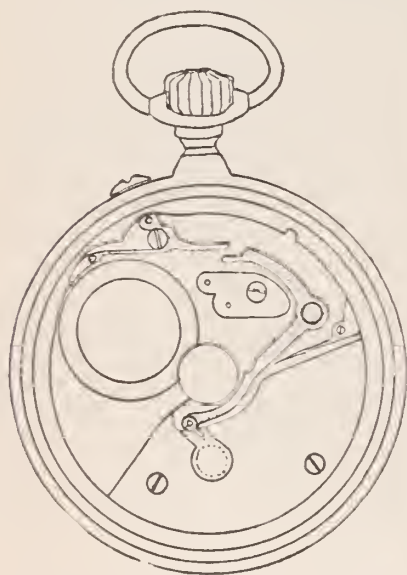

ing to L. de Rosny, to whom the invention has been dedicated. It is represented in the accompanying figure. A long elbowed lever, having two unequal arms, is arranged in the interior of the watch, which can be put in action by a second lever worked by a push piece in the rim of the case. The longest arm of the first lever carries at its extremity, and at a right angle with the direction of its movement, a click or elevator which ends near the circumference of a kind of ratchet fixed on the prolongation of the arbor of the seconds wheel. Ordinarily the elevator does not touch the ratchet, but if the push piece is pressed in sufficiently a displacement of the long lever takes place, carrying the elevator into the teeth work of the ratchet, on which it acts tangentially in order to move forward the wheel bearing the seconds hand. The maximum displacement corresponds to one-fourth of the cir-

cumference, and it can be adjusted to all lesser variations, for it is proportional to the working of the push piece. A slight conicity is given to the prolongation of the arbor to prevent the ratchet from being driven from its position under the repeated movements of the elevator.

The seconds hand can thus be set without moving the central hands.

### Index for Watches.

THIS invention is designed to effect the easy displacement of the index in one direction or the other by means of a guiding piece, pivoting either on the cock or some other part of the watch, as bridge or plate; the index and the revolving piece gearing with each other by means of three teeth carried, one, the intermediary tooth, on one of the pieces, and the two others on the other piece. Two different applications of the principle are herewith represented. In Fig. 1 the intermediate tooth is on the index, while in Fig. 2 this tooth is a part of the guiding piece, the result being the same in both cases. The tooth *a*, Fig. 1, is formed by the finger of the index. It is set between the teeth *d* and *d'*, which form a sort of crescent solidly attached to the arbor *c* pivoting on the cock. This arbor or swivel may be manipulated, either by the slit of a screw, as indicated in the fig-

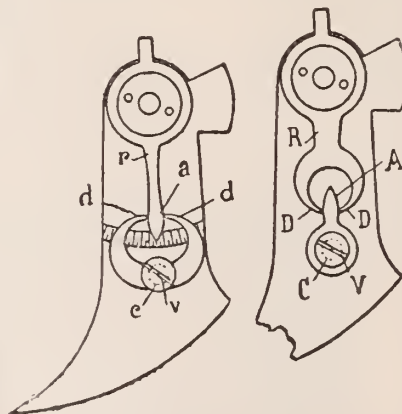

FIG. 1.

FIG. 2.

ure, or by a square, or otherwise. It may, if desired, pass through and work on the cap of the watch, so that the index can be moved without opening the cap. In this case a graduated arc can be traced on the cap concentric with the arbor and supplied with an index, which may be the slit *v*. In

the variation represented in Fig. 2, the single tooth *A*, forming a part of the axis *C*, is set between the two teeth *D* and *D'* terminating the arm of the index *R*, impelling the latter to the right or the left, according to the direction in which the axis *C* is turned.

In both cases a suitable form should be given to the three teeth, which will permit their engagement with the least play possible. The patent can be applied to all kinds and sizes of watches, whatever the form or dimensions of their parts.

### Workshop Notes.

**Greasing Plaster Models.**—Take linseed oil, 1 kilo; calcined lead, 50 grammes; litharge, 60 grammes; umber, 30 grammes; talc, 25 grammes. Boil for two hours at least on a moderate fire; skim frequently and keep in well closed flasks.

**To Blacken Brass.**—The blacking of brass may be accomplished by immersing it in the following solution and then heating over a Bunsen burner or a spirit flame. The immersion and heating are repeated until the brass turns dark, then it is brushed and dipped in negative varnish or dull varnish. The solution is prepared by adding a saturated solution of ammonium carbonate to a saturated copper sulphate solution, until the precipitate resulting in the beginning has almost entirely dissolved.

**Testing Steel for Tools.**—In order to test tool steel for its quality the following process is employed: A bar of the steel to be tested is provided with about nine notches running around it in distances of about 15 millimeters. Next, the foremost notched piece is heated in a smith's hearth in such a manner that the remaining portion of the bar is heated less by the fire proper than by the transmitted heat. When the foremost piece is heated to scintillation, i. e., to combustion, and the calcification of the succeeding pieces gradually passes into dark brownish redness, the whole rod is hardened. A test with the file will now show that the foremost burned piece possesses the greatest hardness, that several softer pieces will follow, and that again a piece ordinarily situated in the second third, whose temperature was the right one for hardening, is almost as hard as the first one. If the different pieces are knocked off, the fracture of the piece hardened at the correct temperature exhibits the finest grain. This will give one an idea of the temperature to be employed for hardening the steel in question and its behavior in general. Very hard steel will readily crack in this process.

## MATTERS IN JEWELRY STOREKEEPING.

That this department shall prove mutually beneficial to our readers, it is desirable that the members of the trade generally communicate with THE CIRCULAR regarding any advantageous device or plan that they are utilizing in connection with their business.

### Best Dressed Windows Among the Retail Jewelers.

#### Series II. No. XIV.

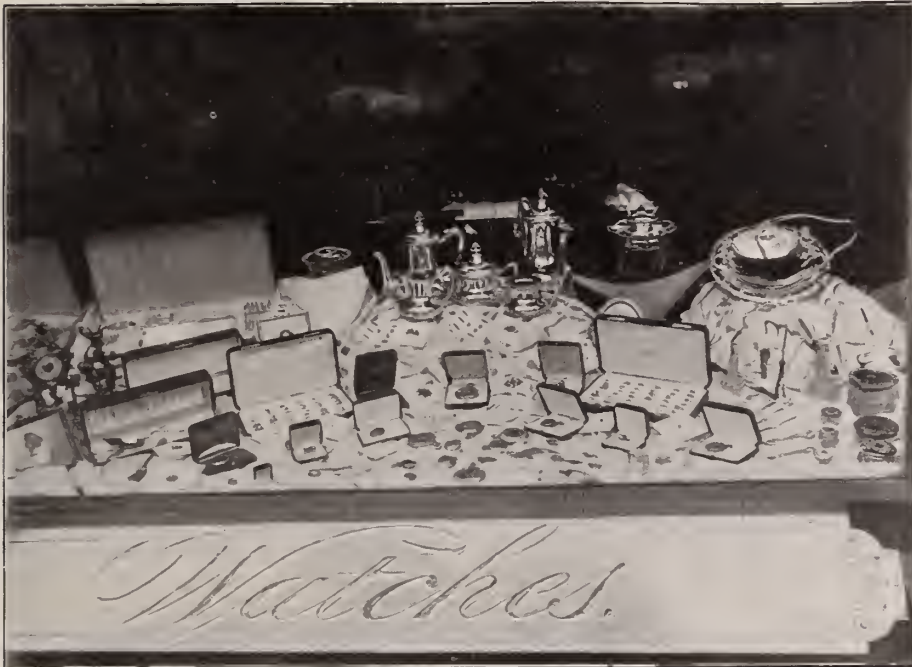

THE SHOW WINDOWS OF J. W. NEASHAM, OTTUMWA, IA.

THE double windows of J. W. Neasham, Ottumwa, Ia., are considered among the most attractive in his neighborhood. Regarding them, Mr. Neasham writes to THE CIRCULAR: "We change our window display twice each week. One window we use for diamond jewelry, watches and other goods in distinctively jewelry and silver ware lines, while the other window is used for cut glass, fine hand decorated china, Rookwood pottery, etc."

### The Importance of Jewel Boxes.

ONE of the most important cares of the jeweler is to arrange the jewelry he has prepared in boxes the best adapted for exhibiting its beauty. From his sagacity and intelligent harmonizing of the colors of the richest wares, his good taste is judged. There are many considerations to be taken into account: the nature of the jewelry, the circumstances under which it is offered, the taste of the person for whom it is designed, none must escape the attention of the jeweler. He ought to keep them in view, in order that his jewels may be fully appreciated, as well as to guide his customer in the selection.

A slight error of taste may be sufficient to spoil, or at least diminish the effect of a present. The person who receives it ought to be not only satisfied, but charmed from the outset by the delicate care, the attention, the taste evinced in the make-up of the jewel box, which is the most convincing proof of the pleasure sought to be imparted. The engagement ring is offered in rather a modest box, while the richest cases are reserved for the ornaments to be given at the time of the wedding. When there are pearls, they are set off by a lining of blue. For diamonds and colored stones other hues are chosen, according to personal taste.

The fashion of white cases, without being an absolute rule, is still in favor for wedding jewelry. For the most beautiful jewels it is customary to affix an inscription in silver on the case.

### New Method for Displaying Goods.

EDWARD ROEHM, of Roehm & Son, Detroit, Mich., has designed a new method for showing goods in a window, that is original. He has a board background slanting backward from the front of the window at an angle of 45 degrees, covered with soft, white cotton corduroy. Upon this slanting surface rest blocks of various shapes, such as prisms, octagons, cubes, etc., cut in such a way as to present upright fronts and flat tops. They are covered with white corduroy and are kept in place by tiny hooks on the back that fasten into the cloth on the board. They can be easily lifted off and rearranged, making a changeable window, which is the principal end to be reached. Designs of jewelry, such as pins, brooches, rings and watches and precious stones present an excellent appearance. The goods are thrown forward towards the spectator more than in the usual window designs. This particular display is attracting much attention.

A novelty in the shape of a white rat was placed in Wm. L. Smith's jewelry store window, Seymour, Conn., recently, where it created much amusement, being placarded "From the Philippine Islands, presented by Michael Hayes."

Cat's eyes are quite conspicuous in fine jewelry.

Gigantic gold hooks and eyes are provided for ladies' cloak clasps.

# BRADLEY & HUBBARD MFG. CO.

Have produced for this season's trade the finest line of goods ever offered.

## Art Metal Goods,

PITCHERS, VASES, CANDELABRAS, FIGURES, BUSTS, TABLES, ETC.....

## Reception Lamps

WITH THE CELEBRATED "B. & H." and B. & H. RADIANT BURNERS. NEW AND ORIGINAL DESIGNS. HANDSOME AND EXCLUSIVE FINISHES.

Dealers are cordially invited to inspect the line of Samples at our SALESROOMS.

NEW YORK: 26 Park Place to 21 Barclay Street.

BOSTON: 160 Congress Street.

CHICAGO: 131 Wabash Avenue.

PHILADELPHIA: 714 Betz Building.

FACTORIES and OFFICES: MERIDEN, CONN.

## Our Hand-made Cases

are constructed in the old reliable way, which is a pride to the Manufacturer, Dealer and Wearer.

STAMPED.



ALL CASES BEARING THIS MARK, ARE HAND-MADE.

STAMPED.



Manufactured by **DUBOIS WATCH CASE CO.,**  
Makers of **SOLID GOLD CASES.**

21 and 23 Maiden Lane, New York.

These well-known Razors, the quality of which is warranted, possess this great advantage, that they may be used for ten years before they require actual sharpening. Before using them it is necessary to rub them on good leather strop. Le Coultre's Stropps (to be had with the Razors) should be used in preference to others.



THIS CUT IS TWO-THIRD OF REGULAR SIZE.

"SPECIAL"—Single Razors for Jewelers' Travelers at trade price.

## MATHEY BROS., MATHEZ & CO.

Send for Price List.

Sole Agents, 21 & 23 MAIDEN LANE, N. Y.



GOLD SHELL.

"Buy direct from the manufacturer and get all that is coming to you."

SEND FOR OUR "HOT CATALOGUE, CONTAINING COLD FACTS AND PRETTY PICTURES."

CLARK & COOMBS,

86 WEST EXCHANGE ST., PROVIDENCE, R. I.

WE ARE HEADQUARTERS FOR.....

Gold Shell Rings...

## THE SWAN FOUNTAIN PEN.

Reputation World Wide.  
Made upon Distinct Principles.  
Is a Compressed Air Pump.  
Simply Wet the Insides to Provoke an Energy.

W. W. Stewart, Inventor and Patentee.

A variety of Styles and Prices

- 3 Sizes Safety Swans.
- 3 Sizes Self-filling Swans.
- 3 Sizes Adjustable Feed Swans.

**MABIE, TODD & BARD,**  
NEW YORK AND LONDON.

**HENRY C. HASKELL,**

11 Maiden Lane, N. Y.,

has a special department for Jewelry repairing of all kinds. Prompt attention. Prices right. Exclusive Design Plates sent dealers upon request.

MAINE ANNOUNCEMENT.

DR. KNOWLES

will continue giving private instructions in

## Optometry

during the month of November in Portland, Me. For terms and important particulars write to

R. H. KNOWLES, M. D.,  
480 CONGRESS STREET,

ROOM 3, PORTLAND, ME.



**FERD. FUCHS & BROS.,**  
**SILVERSMITHS,**  
MAKERS OF STERLING SILVERWARE,  
34 East 29th St., - New York.

**WOOD & HUGHES,**  
Sterling Silverware Manufacturers,  
FINE PLATED WARE,  
No. 24 John Street, - New York.





**THE RAMBLER'S NOTES.**

WHAT THE RAMBLER SAW AND HEARD AMONG THE DEALERS IN ART POTTERY, CUT GLASS, BRONZES, ETC.

CUT GLASS AND IMITATIONS.

UNDER the title of "Cut Glass and Imitations," C. Dorflinger & Sons, 36 Murray St., New York, have issued for the use of their customers a 12-page booklet, explaining exactly what they believe should be considered *cut glass*, and where the line should be drawn between the real and the imitation. The principal subject of the pointed remarks of this brochure is "acid polishing," and while some other manufacturers may take issue with the conclusions drawn herein, the booklet is undoubtedly of interest to C. Dorflinger & Sons' customers, and gives them arguments in favor of this brand of glassware which they will no doubt use with their patrons.

AMERICAN DECORATED FRENCH CHINA.

THERE is to be found among the American decorated china offered to the trade by L. W. Levy & Co., 194 Broadway, New York, some especially rich and attractive effects in large flower subjects. The rose is perhaps the flower most in evidence, though lilac, lily and other effects may also be found. These decorations are shown on a large line of plates, chop dishes, cups, saucers, chocolate pots and sets, jars and small novelties, and in all cover the entire piece. All the articles of this line are of the finest French china, decorated in this country, and show none of the characteristics of imported china. Another line here displayed consists of decorated porcelain handkerchief, jewel, trinket and other boxes, silk lined and trimmed with metal mountings.

NEW PATTERNS IN CUT GLASS.

THE Fall line of J. C. O'Connor's cut glass displayed at his New York sales-rooms, 39 Union Square, is to be remarked for the many new shapes and decorations which it contains. Of the several new cuttings here shown the richest and most expensive pattern is called "Santiago," and in it is a new effect that is sure to prove popular. This cutting is done in circular panels, filled in with hob-nails, the panels containing bands of exquisite detail work surrounding a star.

The most popular priced cutting of the display is called "Olympia," whose salient feature is a feathered prism-like effect, angularly disposed to the periphery of large stars, giving the effect of pin-wheel fireworks. The "Santiago" cutting is shown on a full line, while the "Olympia" appears only on bowls.

THE RAMBLER.

**Old American Turquoises.**

[From *The American Antiquarian*.]

WE know from the narrative of Bernal Diaz and the journals of the Coronado expedition that the turquoise was in general use for personal adornment, and that it was most highly prized, and was an object of trade or commerce between the various tribes. It was also reported as in use at Cibola for the adornment of the portals of chiefs' houses by inlaying. Thus, the Friar Marcos de Niza, in his reconnaissance in Soñora and northward in search of the seven large cities of Cibola, was informed that he would there find the chief doorways ornamented with turquoise. On his way, he met Soñora Indians, returning from the north, who explained that they had been to Cibola to get turquoises and cow (buffalo) skins. Turquoises were suspended from their ears and noses, and they wore belts adorned with turquoises. At one village the chief men were adorned with collars of turquoise, while others were allowed to use them in their ears and noses only. When Castenada reached Tusayan the people presented him with some turquoises. Mendoza, in his letter regarding the seven cities, says: "They have turquoises in quantity." Vasquez reported the use of turquoises in worship as offerings to the gods, and he adds that generally they were poor ones. In Castenada's narrative mention is made of presents of turquoises to the devil by the inhabitants of Culiacan, and also that a certain clan of women were decorated with bracelets of fine turquoises.

In the celebrated Coronado expedition northward from Mexico to Cibola, 1540-42, the negro explorer Estevan, who went with the party, gave the good friars great trouble and anxiety by his greed in collecting turquoises and objects of value from the natives. Estevan appears to have been always ready to press on in advance, an explanation of which may probably be found in his desire to get the first pick of the gems. He was loaded with them on his arrival at the outposts of Cibola, where he was killed and his turquoises confiscated.

**OLD BRITISH POTTERY MARKS**

HOW TO IDENTIFY 17TH CENTURY AND 18TH CENTURY CHINA AND PORCELAIN.\*

[Commenced in issue of Nov. 15.]

**Bristol Porcelain.** (1773). — The best known among the British Bristol porcelain marks is a simple cross (Fig. 6a and 6b) in blue or slate color printed on the glaze. The capital letter B (Fig. 7a and 7b) has been likewise identified as an undoubted Bristol mark. Both these marks are commonly accompanied by numbers varying from 1 to 24, and indicating the



FIG. 6a. FIG. 6b. [FIG. 7a. FIG. 7b.]

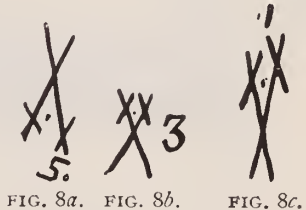

FIG. 8a. FIG. 8b. FIG. 8c.

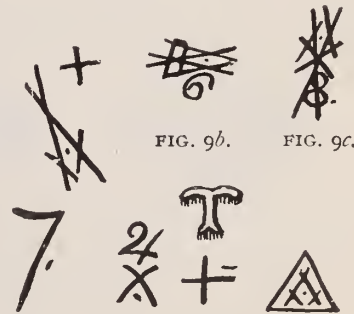

FIG. 9b. FIG. 9c.

FIG. 9a. FIG. 10. FIG. 11. FIG. 12.

decorator of the specimen. The Dresden mark of crossed swords is frequently found on Bristol china, blue under the glaze (Fig. 8a, 8b, and 8c), sometimes combined with the cross, the letter B, and painter's number over the glaze (Fig. 9a, 9b, and 9c). When a number in gold is added to the Dresden, or any other Bristol mark, it indicates the gilder, not the painter. In a few cases the Plymouth mark is used in connection with

\*Adapted from the *Pottery Gazette*.

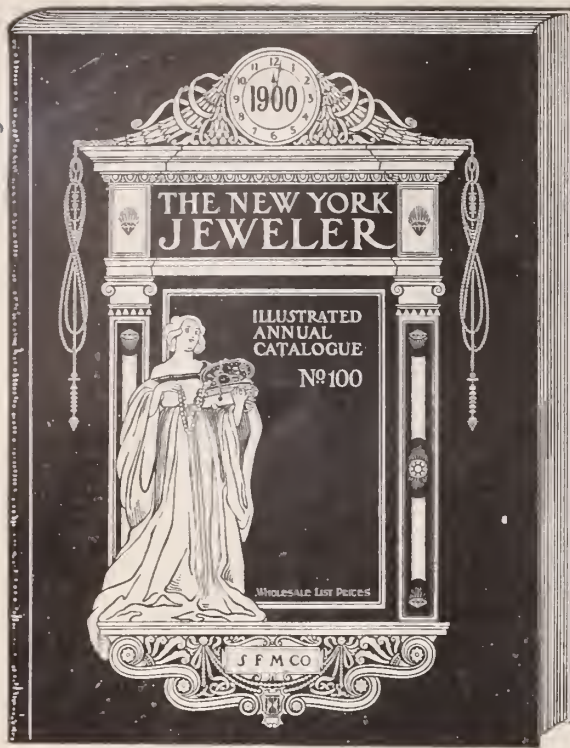

ILLUSTRATION 1-6 SIZE.

# OUR NEW CATALOGUE

Just out.  
List Prices Only.

724 PAGES, 9 x 13.

For 26 years the acknowledged authority for choice designs in reliable goods and the lowest prices current in the New York market.

WATCHES,  
DIAMONDS,  
JEWELRY,  
OPTICAL GOODS,  
SILVER NOVELTIES,  
MUSICAL MDSE.,

Clocks, Lamps,  
Cut Glass, Silverware,  
Fine Leather Goods  
And Stationery,  
Photographic  
Supplies,  
Jewelers'  
Sundries, Etc.

**S. F. MYERS CO.,** Manufacturers, Importers  
and Wholesale Jewelers,

MYERS BUILDING, 48 & 50 MAIDEN LANE, 33 & 35 LIBERTY STREET, N. Y.

Address Department No. U 10 when sending for catalogue.

## The "Bryant" Rings.

ARE KNOWN TO THE JEWELER'S CUSTOMERS AS THEY ARE TO THE JEWELER, HAVING FOR 50 YEARS OCCUPIED THE PROUD POSITION OF "THE BEST."



THE "BRYANT" MARK IS ACKNOWLEDGED TO BE A GUARANTEE OF QUALITY, STYLE AND FINISH.

GOODS SENT ON APPROVAL TO RESPONSIBLE DEALERS.

Our new Fall line comprises a profusion of new designs.

**M. B. Bryant & Co.,**  
10 Maiden Lane, New York.

**WM. H. BALL & Co.,**

MANUFACTURING JEWELERS,

Anderson Building, 12-14-16 John St., N. Y.



Our Specialty:

**Everything in  
Gold Bracelets.**

Curb Bracelets, Bangle Bracelets, Fancy Stone Bracelets, Baby Esther Bracelets, Bracelet Mountings

the Bristol mark (Fig. 10); and some specimens bearing the Plymouth mark alone, but closely resembling Bristol in texture, may have been made at Champion's works under the Plymouth patent, between 1770 and 1773. Figs. 11 and 12 represent two marks found on a few pieces of undoubted Bristol porcelain. In Fig. 11 the letter T is embossed or raised; the cross painted in blue. Fig. 12 (the Dresden cross in a triangle). Another impressed mark, T°, occurs on the set of figures representing the elements, and may, perhaps, be ascribed to the modeler Tebo.

**Bow Porcelain** (1730 to 1760).—The present state of our knowledge concerning the marks which undoubtedly belong to the Bow works, is far from satisfactory,

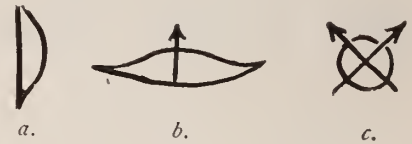

FIG. 12.

and will perhaps remain so. Four different classes of marks have been appropriated for Bow. The bow (Fig. 12, a, b, c), the arrow (Fig. 13, a, b, c, d, e), the anchor (Fig. 14, a, b), and the dagger (Fig. 15, a,

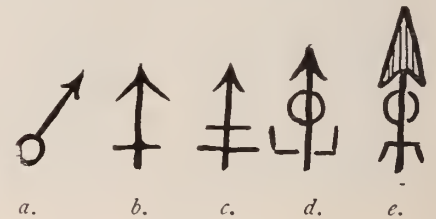

FIG. 13.

b, c). They appear variously drawn, either single or in groups scratched in the clay or penciled on the glaze, in red, blue, brown, and black. Sometimes a cross and crescent are added (Fig. 16 a, b). The bow or arrow marks are generally found

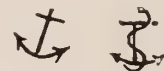

FIG. 14.

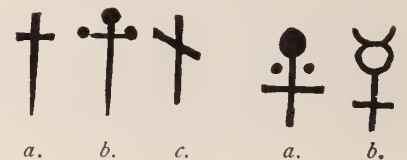

FIG. 15.

FIG. 16.

on small pieces, as saltcellars, butterboats, &c.; an anchor, combined with a dagger, and sometimes with a crescent, on figures. The marks illustrated in Fig. 16 are of rare occurrence. The anchor mark is, by some connoisseurs, claimed exclusively for Chelsea porcelain; but, however that may be, it is sufficient for the collector of old English china to know that any piece on which one or a group of the above marks occurs is valuable.

(To be continued.)



# Stella Music Boxes

ARE UNEQUALED FOR

Sweetness,  
Harmony and  
Volume

of tone, and have smooth  
metallic tune sheets playing  
thousands of tunes.

**Why Not** handle a line of Music Boxes the sale of which you can control and **Make Money?**

WRITE FOR CATALOGUE AND TERMS.

**Jacot & Son,** 39 UNION SQUARE,  
NEW YORK.

## SILVER NOVELTIES

### SIMMONS & PAYE,

"The Souvenir House,"

129 Eddy St., Providence, R. I.,  
will mail to any jeweler on request a  
copy of their latest catalogue, illus-  
trating manicure goods, toilet goods,  
and silver-mounted glass goods.

## CROUCH & FITZGERALD,



Jewelry Trunks  
and Cases,  
161  
Broadway,  
Bet. Cortlandt and  
Liberty Sts.  
688 B'way,  
723 6th Av.  
NEW YORK.

## W. C. A. WESTPHAL,

WATCHMAKER,

41 Maiden Lane, NEW YORK.

Established 1892. Telephone, 3684 Cortlandt.

Estimates, Repairing, Adjusting of Chronometers, all  
Complicated Watches and Fine Time Pieces.

### DEMAGNETIZING.

Watches made Non-Magnetic.

Fine Wheel and Pinion Cutting

**JUNK-SHOP METHODS.** The time is not far  
distant when a jeweler will de-  
mand different methods than are now employed by  
some salesmen in disposing of their stock. How any  
jeweler with any reputation will allow an auctioneer  
to run in a lot of inferior goods and sell them on his  
reputation, using his store for a junk-shop to dispose  
of the auctioneer's goods, not his, is a hard problem to  
solve.

**E. J. GREGORY, Jewelers' Auctioneer,**  
Jewelers' Building, Boston, Mass.

## KETCHAM & McDOUGALL,

MANUFACTURERS OF

GOLD AND SILVER  
THIMBLES

ESTABLISHED 1832.

**M&D**

TRADE-MARK.

And the improved

Automatic Eye-Glass Reel.

37 MAIDEN LANE,

NEW YORK.



No. 144



Pat'd Nov. 30, '94

SEND FOR  
CATALOGUE C.

## SEE THE TWO ANCHORS AND THE NAME ROGERS

TRADE MARK:

Like This  **ROGERS**  "ANCHOR"  
BRAND

**Silver Plated Ware.** Get the Silverware which bears the above  
impression and then nobody can have any  
better than you'll have in the ROGERS

ANCHOR BRAND. New designs all the time. Same through and through quality  
all the time. The Rogers Anchor Brand is made only by us.

Factories:

Hartford, Conn. Norwich, Conn.  
Wallingford, Conn. Taunton, Mass.

**WM. ROGERS MFG. CO.,**  
HARTFORD, CONN.

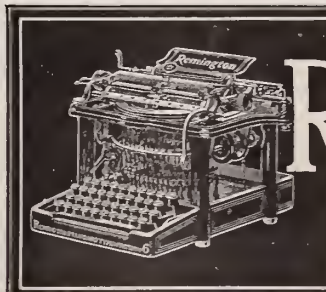

Absolutely Reliable Always  
**Remington**  
Typewriter

STANDS THE TEST OF CONSTANT SERVICE

Wyckoff, Seamans & Benedict  
327 Broadway, New York

# DIAMONDS.

LARGE ASSORTMENTS.

DESIRABLE SIZES.

ATTRACTIVE PRICES.

**R., L. & M. FRIEDLANDER,**

30 MAIDEN LANE, N. Y.

97 HATTON GARDEN, LONDON.

## HALL CLOCKS,

*Mantel Clocks,  
Traveling  
Clocks,  
Clock Sets,  
Regulators,  
Bronzes,  
Vases, Ivory  
Miniatures  
and Art Goods.*



Fall Line Now Ready.

**Harris & Harrington,**

32 and 34 VESEY ST., NEW YORK.

Sole Agents to the Trade for J. J. Elliott & Co., London.

IMPORTERS AND CUTTERS OF **Diamonds** 65 Nassau St. NEW YORK. Cor. John.

**DIAMONDS** Importers and Cutters. **L. & M. KAHN & CO.,** 172 Broadway, Cor. Maiden Lane, N. Y. **DIAMONDS**

## CUT GLASS

**Whiskey Bottles,  
Brandy Bottles,  
Clarets, Decanters,**  
with and without  
**Silver Mounts.**

ABSOLUTELY NEW  
GOODS PARTICULARLY  
ADAPTED FOR MEN.

**LE BOUTILLIER & CO.**

18 East 17th St., New York.

## HOROLOGICAL DEPARTMENT, BRADLEY POLYTECHNIC INSTITUTE, PEORIA, ILLINOIS.

Largest and best watch school in America. We teach Watch Work, Jewelry, Engraving, Clock Work, Optics. (Formerly Parsons' Horological Institute.) Catalogue Free.



GOLD AND SILVER PENCILS,  
PENHOLDERS, &c.

**FAIRCHILD & JOHNSON CO.**

Office and Factory,  
220 FOURTH AVENUE, N. Y.

## L. LELONG & BRO.,

Gold and Silver

Southwest Corner of  
HALSEY and MARSHALL STREETS.

**REFINERS,  
ASSAYERS and  
SWEEP SMELTERS.**

**NEWARK, N. J.**

**Sweepings a Specialty.**

**H. M. RICH & CO.,**  
Jewelry - Auctioneers,  
7 and 9 Franklin St.,  
BOSTON, MASS.



No. 1946. No. 1947. No. 1948.

Factory, 100 STEWART ST., PROVIDENCE, R. I.  
New York Office, 11 John St. Chicago Office, 131 Wabash Ave.

A COMPLETE LINE OF  
**FRIENDSHIP HEARTS AND LUCKY BANGLES**  
FOR HOLIDAY TRADE.

**S. & B. LEDERER CO.**

ALBERT LORSCH.

TELEPHONE CALL, 744 CORTLANDT, N. Y.

ALFRED KROWER

# ALBERT LORSCH & Co.,

LORSCH BUILDING,  
37 & 39 MAIDEN LANE, N. Y.,

167 WEYBOSSET ST.,  
PROVIDENCE, R. I.

JUST RECEIVED, A LARGE SHIPMENT OF

# DIAMONDS IN ALL SIZES.

**PROV. STOCK CO.** HIGH GRADE ROLLED PLATE  
**Chains**  
BRACELETS, LORGNETTES.

**10K. GOLD**  
Scarf Pins, Brooches,  
Neck Chains, Lorgnettes,  
Bracelets.

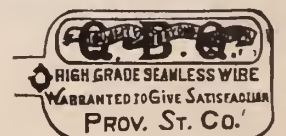

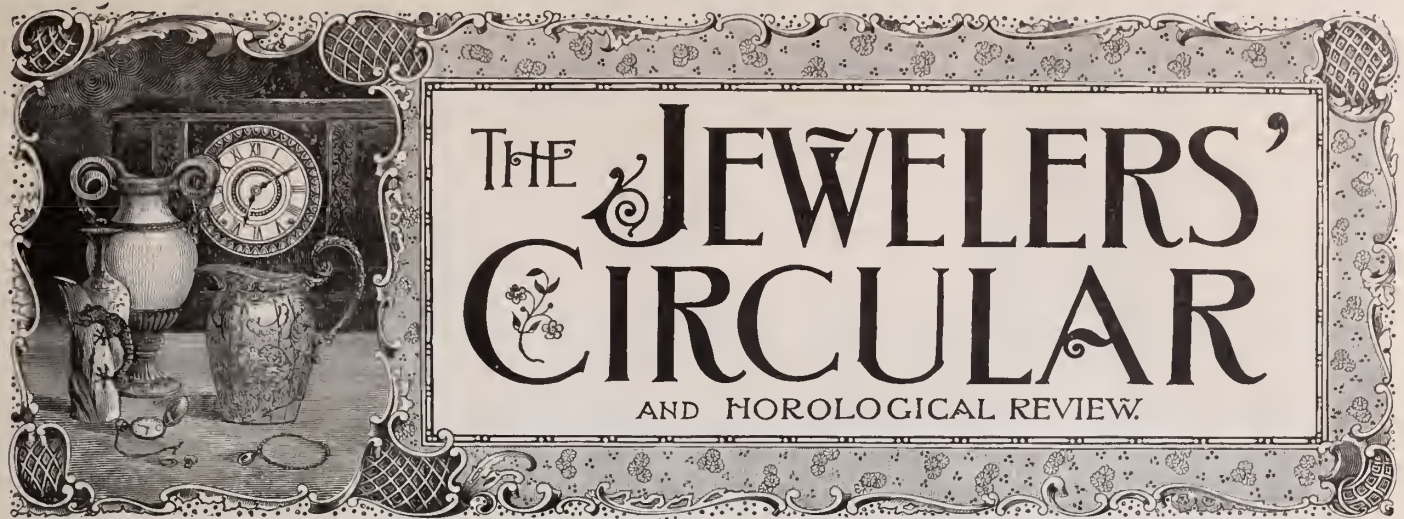

Corbin Building, 11 John St., Corner Broadway, New York.

Copyrighted by THE JEWELERS' CIRCULAR PUB. Co.

Entered at the Post Office in N. Y. as second-class matter.

VOL. XXXIX.

NEW YORK, WEDNESDAY, NOVEMBER 29, 1899.

No. 18.

## PRIZE DESIGNING IN HIGH CLASS JEWELRY.

THE second *concours* for designers organized by La Chambre Syndicale de la Bijouterie, Paris, this year had for its theme a design, natural size, of a piece of jewelry to be worn at the corsage. Fifty competitors responded. A number of those not possessed of the necessary professional knowledge misconstrued the meaning of the word, jewelry, and their designs, though very interesting and not without

ble at a distance, and the proportions of the piece are good, though the shining star at the top is a little heavy and the whole reminds one of certain compositions by Mucha which are so much in vogue at present. Apropos of this head, which may be executed in gold, in enamel, in hard,

be worn." We do not entirely share this opinion, and without desiring to cite the examples of the Greek, of the great artists of the Renaissance and many others, we believe that the human form employed with taste and discernment is, on the contrary, a proper element with which to uplift the jeweler's art and render it more interesting. Certain contemporary artisans are proving this fact strikingly every day.



2D PRIZE DESIGN FOR ORNAMENT.  
[Slightly reduced.]

real merit, have been rejected from the beginning as not coming within the scope of the competition.

The first prize has been awarded to Mr. Marchand for the design which we reproduce herewith, representing a female head, whose hair dress, richly decorated with stars and diamond ornaments, is arranged in the shape of sinuous curls. The lines are sufficiently simple to be discerni-



1ST PRIZE DESIGN FOR CORSAGE ORNAMENT.  
[Slightly reduced.]

semi-transparent stone or even in ivory, we would like to state what we think of the employment of the human figure in jewelry, writes Henri Vever. Certain authorities, not the minority, hold that "the entire figure in *plein relief* is out of place in a piece of jewelry which is destined to



3D PRIZE DESIGN FOR ORNAMENT.  
[One-half size.]

But this is an element which does not admit of mediocrity, for then it is liable to run into the ugly and the grotesque.

The second prize was given to Mr. Douy-Pascual for a branch of mimosa, freely interpreted and sufficiently *stylisée*, although it bears some resemblance to the mistletoe. It has been designed with taste, and is highly suitable to be executed as jewelry. Georges Ecalle obtained

# Our New Lines For The Spring Trade

will be ready right after Christmas, and as we are sparing no effort or expense to bring them to perfection they will be lines not surpassed by any on the market during the season. The quality will be up to our usual high standard of rolled-gold plate, while the finish is the finest that can be produced.

LOCKETS, CHARMS, BRACELETS, CHAINS, PINS, EARRINGS, SILK VEST CHAINS and HAIR CHAIN MOUNTINGS; also a large variety of those dainty little BROOCHES now in vogue, and an enlarged line of BUCKLES.



Do not allow your stock of STERLING SILVER TOILET and MANICURE GOODS and NOVELTIES to get too low, as you will have a good demand for them all through the Holiday Season.

OUR CATALOGUE IS YOURS FOR THE ASKING.

**THEODORE W. FOSTER & BRO. CO.,** 100 RICHMOND ST., PROVIDENCE, R. I.  
Successors to FOSTER & BAILEY.

## A USEFUL NOVELTY

### Bottle Openers,

in Sterling Silver and Silver Plate. The convenience and cleanliness of this form of bottling having brought it into general use, these Openers will be appreciated for the table. Send for catalogue.

MADE BY  
**Goodnow & Jenks,**  
SILVERSMITHS,  
Stanhope and Morgan Sts.,  
Boston,

who have obtained the SOLE RIGHT from patentees to manufacture this article.



# The Best.

## The "DOUBLE-BASE" Engraving Block

shown upon this page is regarded by the users of the same as the best block for the price, viz. :

### \$15.00,

on the American market. The attachments, consisting of Spoon Holder, Button and Bangle Attachments, Ring Holder, Cement Plates, 8 sets (4 each) Pins and Pegs, and Leather Pad, are more than are given with any other block. It is a better finished block and more work can be done with the same than with any other block offered for sale.

### An Absolute Guarantee Is Given With Every Block.

In addition to the above attachments, we can furnish you with a Thimble Holder (2 pieces) for 50 cents; Cane and Watch-Cap Holder (4 pieces) for 75 cents; Cement Plates from 25 cents to 50 cents, and Polished Hardwood Base, with drawer and glass shade, for \$3.50.

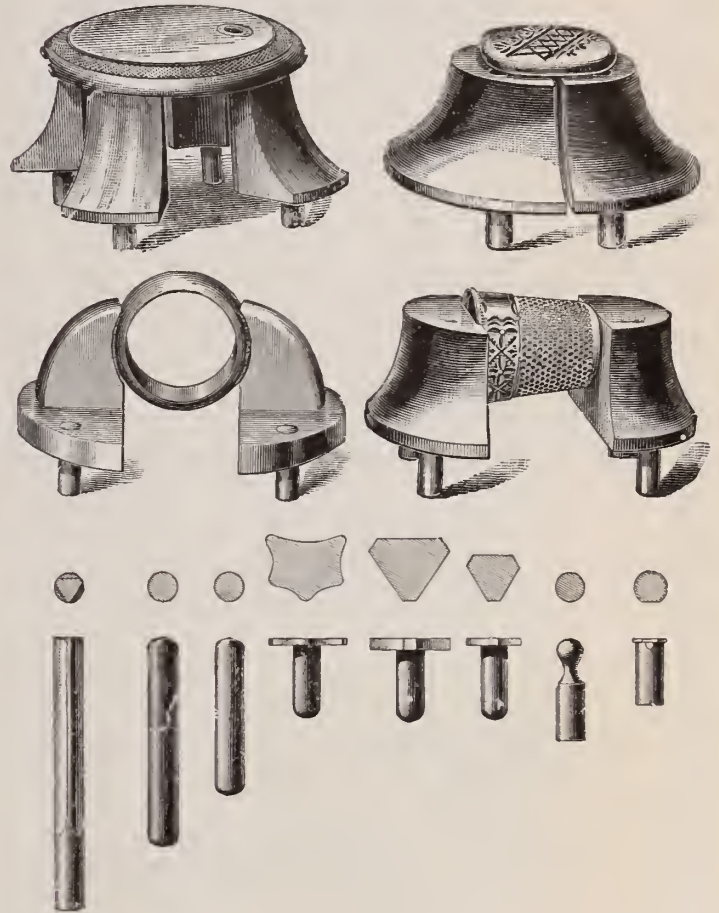
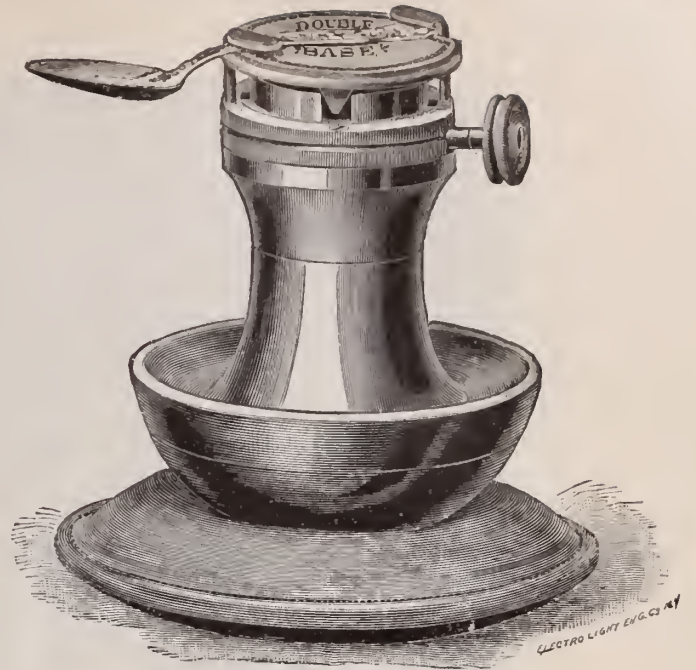

## L. C. REISNER & CO.

Manufacturing Jobbers, Importers and Exporters,  
Watch Materials, Tools and Supplies,

Jewelry Repairers for the Trade.

LANCASTER, PA.



"Watch Our Ads."

*Prices on Application.*

**The Mauser Manufacturing Co.,**

**...SILVERSMITHS...**

15th Street, between Broadway and 5th Avenue, NEW YORK.

# Of Greatest Importance

to the live manufacturing Jeweler is a careful consideration of our lines of Jewelers' Findings.

NEW ASSORTMENTS OF

## Buckles, Galleries, Brooches, Settings, Pins, Etc.

### THOS. W. LIND,

MANUFACTURER OF JEWELERS' FINDINGS,

67 FRIENDSHIP STREET,

PROVIDENCE, R. I.



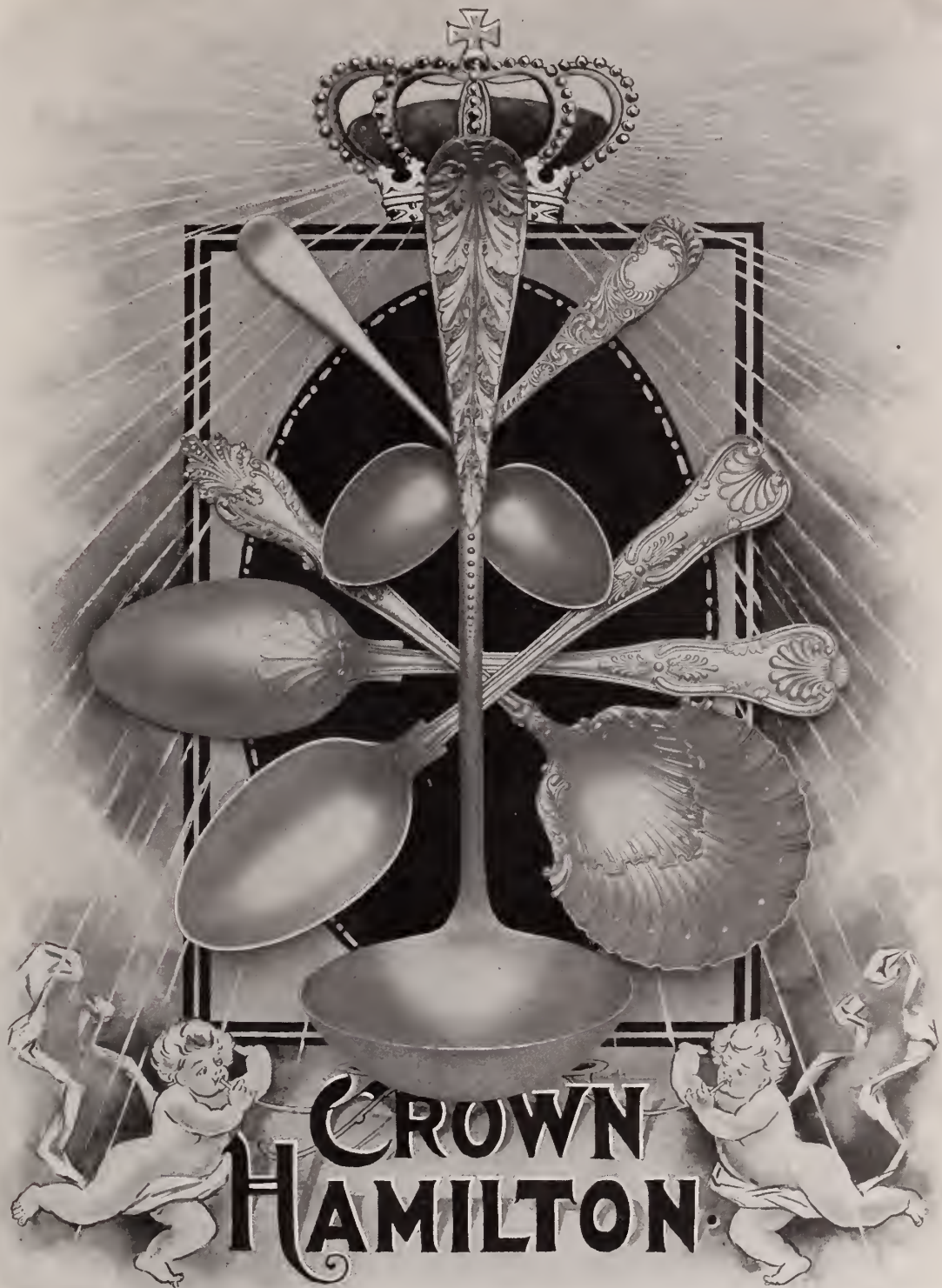

HIGHEST GRADE Silver Plated Flat Ware Ever Manufactured in This or any Other Country.

**THE ROGERS & HAMILTON CO.,**

New York:  
9-11-13 Maiden Lane.

Factory K, International Silver Co., Successor.

**WATERBURY, CONN.**

**ALMOND DISHES**  
**SOMETHING FOR YOUR**  
**HOLIDAY TRADE**

THESE DISHES ARE OF GOOD  
WEIGHT AND THE PRICES  
AT WHICH WE ARE SELLING  
THEM PERMIT OF THEIR  
BEING USED AS LEADERS  
BON · BON · DISH  
TO MATCH... WRITE  
FOR PRICES  
ILLUSTRATIONS  
FULL SIZE



NO. 257.



NO. 258.



NO. 1000.

**R. WALLACE**

**& SONS MFG. CO.**

**SILVERSMITHS**

**WALLINGFORD · CT.**

**BRANCHES**

**226 · 5<sup>TH</sup> · AVE · NEW · YORK**

**109 · WABASH · AVE · CHICAGO**

**120 · SUTTER · ST · SAN · FRANCISCO**

the third prize for designs which are well adapted for jewelry after making a few slight changes. His *motif* of iris flowers and leaves lends itself well to that purpose, and for this reason the jury preferred it to other designs by this competitor, which are, perhaps, superior.

We would enumerate the competitors who have obtained a mention: Mr. Truffier, whose design does not lack originality, and who also seems to be inspired by Mucha. His mistletoe branch with a female head, personifying Winter, as well as his *motifs* with peacock feathers, is charming. Mr. Ehrenfeuchter, who shows us an octopus with green eyes, the body being represented by a large diamond in the shape of a shuttle, which with feelers from which are suspended black and white pearls. A row of small colored stones, olivines or topazes, puts its discreet note into this object, which would make a handsome jewel, but whose beauty would, according to our idea, be enhanced if the pearls were held directly by the feelers instead of being suspended on little chains. This design is herewith reproduced. Mr. Vergnolet has received a mention for his composition of three umbels surrounded by circles. This is an ornament well poised and of distinguished aspect.

Beside these rewarded pieces there are others which deserve recognition for various reasons: Those of Mr. Leroy, which present pretty branches of chrysanthemums and iris, ably composed but too natural and conveying the impression of something one has seen before. His square *bordures de corsage*, embellished with mimosas, clover and lilies-of-the-valley in diamonds are more attractive. The trimming of mistletoe sent by Mr. Feraille does not lack in merit.

Miss Charmois and Messrs. Deslignères, Landry, Coutreau, Léger and Corrette merit a citation on various accounts. The two principal designs by Mr.

Corrette are much too complicated. One symbolizes the "Year Which Comes, Passes and Departs." The year is personified by a figure in chased gold, having at its side the day and night symbolized by a rooster and an owl on enameled tablets. Arranged above this are the signs of the zodiac, likewise enameled and framed by a diamond ornament. The other subject, "Night Fleeing from the Sun," is better, because it is simpler, but it is still sur-



MENTION DESIGN FOR CORSAGE ORNAMENT.  
[One-half size.]

charged. The sun is very cleverly rendered by a splendid yellow diamond encircled by rays of white brilliants. To represent night Mr. Corrette has designed a female head in carved opal, placed in the center of two large, outspread bats' wings, destined to be executed in translucent enamel. The golden hair dress is adorned with poppies, the ribbing of the wings is set with diamonds, and a field of stars of unequal size, traversed by little bats, seems as though suspended in space under cover of night. Certainly there is an idea, but the design would benefit by being less complicated and overburdened. This jew-

el, greatly simplified, would be unique and interesting.

It is a pity that the competing ladies did not succeed better than they did. Much was expected from them, as they should understand the true meaning and purpose of jewelry, but unfortunately the wish was not realized. We must, however, give justice to Miss Vimont for her three plates, a little Oriental in appearance, united by a chain of flowers, and to Miss Delillier for her violet, tulip and umbel ornaments, the last one composed of flowers much too small to produce a good effect in jewelry. They are a little waggish and complicated. On the whole the *concours* has borne fruit in attracting a certain number of young artists and causing them to devote themselves to a branch of industry which is among the most interesting and which gives them ample opportunity to unfold their talents and their inventive genius.

**Demand for Old English Pewter.**

OLD English pewter has been for some time a fad among collectors. Interesting articles on the subject in the *Art Journal* by Davis Benn show that in order to supply the demand not only are all manner of jugs, lamps, epergnes, etc., in foreign pewter placed in dealers' windows, but the original old English moulds have been unearthed and are being used for the wholesale production of "antique" pewter plates and other articles. The usual faking to simulate age is done so cleverly as to deceive the most expert. Some auction prices quoted show great variety. Recently six eight inch or nine inch plates sold for 21 guineas; two five inch plates with arms for 23s. and 35s. respectively, while a 16 inch plate fetched £5.

E. L. Hoges, Warren, Ark., has given a chattel mortgage for \$100.

H £

We Manufacture  
Knives, Forks, Spoons and Cutlery.  
Hollow Ware, Toilet Ware and Manicure Pieces.

The Kind that is sought in Jewelry Stores  
Not found elsewhere.

HOWARD STERLING CO  
Silversmiths.  
Providence · New York · San Francisco.

### The Workings of the Dominion Tariff Law on Travelers' Samples.

MONTREAL, Can., Nov. 15.—The Montreal *Journal of Commerce* published an article on Sept. 29 on the shortcomings of the Tariff law, with the heading, "How to Kill British Trade." To this an English correspondent, who is engaged in the manufacturing jewelry and silversmith trade, in London, writes as follows: "I fully endorse every word of your leader. Last year I visited Canada with my samples only, no two articles alike. I had them in three large boxes, and was very much surprised to find that I was charged 30 per cent duty not only on my samples, but also on the boxes in which they were packed. I had to pay £76, English money (\$369.36) before I could get them through the Custom House. I had intended to come every year, and so build up a trade in Canada, but can you imagine my surprise when I found there was no rebate when I wanted to return? What I did not sell I had to bring back and lose my money. All this simply means that when I again take the trip I shall come empty handed, and it is a question if I come at all. Is this the way to encourage trade with England? The sooner Canada alters her policy the better for her and England." To which the *Journal* replies:

"The above case differs somewhat from the one we referred to on Sept. 29. In that instance the samples were not offered for sale, nor intended for sale, being samples only. In the case above narrated our correspondent says, 'What I did not sell in

Canada, I had to bring back and lose my money,' which implies that some of the samples were sold. It is evident, therefore, that if the whole of the samples had been admitted free of duty, those which were sold would have had an unfair advantage over the goods of Canadian importers who had paid a duty on them. It is also evident that if a package of samples is broken by some being taken out for sale it would be practically impossible for the Customs officers to identify those which were left unsold and taken out of the country by the merchant who had brought them in as samples. A claim, therefore, for rebate on such unsold goods would be most difficult to maintain in the absence of such identification. A wide opening, too, would be made for fraud on the Customs, as goods of one quality could be brought in and rebate claimed on goods of a different class." The *Journal* concludes: "The problem is a difficult one, but until British merchants are afforded better and less costly facilities for displaying samples of their wares when soliciting orders in Canada, the manufacturers of Great Britain will be handicapped in their efforts to build up a trade in this Dominion. Our correspondent complains, also, of being kept three days waiting for his samples to pass the Customs, during which time he was wasting his money and time hanging about unable to seek business. This, however, is a comparatively minor affair, but the obstacle put in the way of showing samples answers our question, 'How to Kill British Trade.'"

### American Clock Factory Reported to Be Proposed for Japan.

[From Tokyo, Japan, *Commercial Journal*.]

There is now maturing a scheme for establishing a large clock factory at Nagoya under the auspices of Ansonia (?) Clock Factory of America. The factory will, we hear, be established there backed by a capital of 2,000,000 yen. Nagoya is a center of the clock manufacturing business, having upwards of 10 establishments of the kind, and it is from this place that our clocks have been exported to China, Korea, India and other neighboring countries in considerable quantities during recent years, though the exportation has shown a great diminution of late in consequence of deterioration in the quality of the articles. Now that the above enterprise has reached the ears of the local manufacturers, they are panic stricken, and a story goes to the effect that the rival local manufacturers may ultimately become united into one powerful establishment so as to compete with the proposed foreign factory.

Joseph Schweizer, of the Ansonia Clock Co., New York, when shown the above extract, said there was no truth in the report, as far as his company were concerned.

Chas. E. Berry, of Hopkinsville, Ky., will open a jewelry store with a new stock in Clarksville, Tenn., on Jan. 1. Mr. Berry has lived in Clarksville before, having been in the employ of Quarles Bros. The style of the new firm will be Chas. E. Berry & Co.



Bonbon Dish,  
No. 2142.

"Sterling Silver Goods Only."

This is only one of our new

**BONBON DISHES**

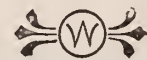

TRADE-MARK.

**FRANK M. WHITING  
& CO.,**

**Silversmiths,**

**NORTH ATTLEBORO, MASS.**

1128 Broadway, New York.

220 Sutter St., San Francisco.

Complete line of Samples always on display  
at our New York Office.

Our line of Dishes, Trays, Bowls,  
Tea Sets, Loving Cups, Toilet  
Goods, etc., is very complete  
this season.

**WATCH CASE GUARANTEES.**

**THE RETAIL JEWELERS SPEAK OUT AND GIVE THEIR IDEAS ON AN IMPORTANT MATTER BEARING UPON THEIR TRADE.**

[This series of letters began in issue of Nov. 15.]

It was upon the request of several responsible jewelers that THE CIRCULAR entered upon the undertaking of obtaining a consensus of opinion from the retail trade regarding the guaranteeing of gold filled watch cases, and sent to a large number of jewelers, indiscriminately, a letter of which the following is a copy:

New York, Sept. 8, 1899.

WE ARE SENDING THIS LETTER TO THE RETAIL TRADE WITH THE OBJECT OF GETTING THEIR VIEWS ON AN IMPORTANT SUBJECT, NAMELY: THE GUARANTEEING OF FILLED WATCH CASES. FROM THE RESPONSES RECEIVED MAY BE EVOLVED SOME VALUABLE SUGGESTIONS.

OF THE FOLLOWING FORMS OF GUARANTEE, WHICH DO YOU CONSIDER MOST JUST, AND WHAT ARE YOUR ARGUMENTS ON THE SUBJECT?

1. SHOULD THE MANUFACTURER GIVE A NEW CASE OF THE SAME GUARANTEE IN EXCHANGE FOR THE OLD CASE THAT HAS NOT LIVED UP TO ITS GUARANTEE?

2. SHOULD THE MANUFACTURER EXCHANGE THE CASE THAT HAS NOT LIVED UP TO ITS GUARANTEE WITH ONE OF LOWER GUARANTEE? THAT IS, IF A 20-YEAR CASE HAS BECOME DEFECTIVE AT THE END OF 10 YEARS, SHOULD IT BE REPLACED WITH A 10-YEAR CASE?

3. SHOULD THE MANUFACTURER REPAIR THE CASE AND PUT IT IN CONDITION TO OUTLIVE THE UNEXPIRED TERM, IF THE CASE SHOWS THE BASE METAL BEFORE THE LIFE OF THE GUARANTEE HAS EXPIRED?

4. SHOULD HE GIVE A NEW CASE AND CHARGE FOR THE LENGTH OF TIME THE CASE THAT DID NOT LIVE UP TO ITS GUARANTEE HAS BEEN WORN; IN OTHER WORDS, REBATE FOR THE UNEXPIRED TERM OF GUARANTEE?

YOURS VERY TRULY,

THE JEWELERS' CIRCULAR PUB. CO.

All those jewelers who did not receive this letter are cordially invited to send their views upon this subject, replying to the questions seriatim or collectively. Their replies will receive the same measure of considera-

tion as those received direct from the letters themselves. The more views on this subject expressed by the trade at large the more convincing will be the conclusions reached.

[Third series of replies.]

LONDON, O., Sept. 11, 1899.

Editor of THE JEWELERS' CIRCULAR:

I received your letter this morning in regard to the guarantee of filled cases. In regard to the first question I consider that the company guarantee should be filled with goods of same quality, for in making the sale of a 20-year case, we state that if the case fails it will be replaced by as good as the original case.

2d. I find that the companies (with the exception of two companies) do not make good their guarantee of the cases. The last one I sent to a certain company I received a plated one which the owner of the case would not have, so I had to replace with one of another firm.

3d. I would not consider the repair question good, as I have had one of that kind that failed.

4th. No. Respectfully yours,  
O. L. BOISOL.

WARREN, O., Sept. 11, 1899.

Editor of THE JEWELERS' CIRCULAR:

Replying to your letter of 8th.

No. 1 and 2. I think if one case warranted 20 years only lasts 10 years it will take two of them to fulfill the contract. I do not think it possible to repair a filled case which has worn off. I think a manufacturer when he finds his cases do not last 20 years should reinforce the weak points and make a case that will last the time out.

It is a great damage to the retail jeweler to have cases coming back, and the least the manufacturer can do to square it with him is to send a new case fully as good as the old one, which was not as good as represented.

Yours truly,  
THAD ACKLEY.

SOUTH BEND, Ind., Sept. 11, 1899.

Editor of THE JEWELERS' CIRCULAR:

In answer to yours of the 8th, will say some watch case companies had better withdraw their guarantee altogether, as I have had cases guaranteed for 10 years that have come back to me in one week. My judgment is never to guarantee any-

thing unless you are strictly honest in what you say, and always do a little more to fulfill that guarantee than a little less. People will never be satisfied with a 10-year case if they have had a 20-year.

Yours,

FRANK MAYR.

WARREN, O., Sept. 11, 1899.

Editor of THE JEWELERS' CIRCULAR:

We are of the opinion that a case should be given by the manufacturers that will wear out the unexpired term of the same quality that the original case was.

Yours respectfully,

VAUTROT & SIDELLS.

SEYMOUR, Ind., Sept. 11, 1899.

Editor of THE JEWELERS' CIRCULAR:

I answer your questions as follows:

1. No.

2. I think the trade would be satisfied to exchange case with one of a lower guarantee.

3. It is never satisfactory to customers to repair case.

4. To charge a customer the difference for the length of time the old case has been worn and a new one will not do, as it is the same as trying to sell him a new case which he does not want to buy.

Respectfully,

J. G. LAUPUS.

HILLSBORO, Ill., Sept. 12, 1899.

Editor of THE JEWELERS' CIRCULAR:

In reply to your circular letter of Sept. 8 I would say that the only way out of the filled case difficulty is for the manufacturers to put enough gold into the cases to make them last the correct time of the guarantee, and then charge enough for them. To put a snide case on the market and then try to dodge the responsibility isn't the way to do a successful business.

I have now before me an 18 size hunting case, made by a leading manufacturer, for which I paid \$4, which with the cash discount off is \$3.60. This case is warranted for 10 years. How many of these cases will wear the 10 years? I say none. Yet I must sell it because my neighbor does. I point out to my customer the excellent standing of the people who make it and then await results.

THE APOLLO 

WARRANTS THE EPITHET "POPULAR,"

as shown by sales from Maine to Oregon.

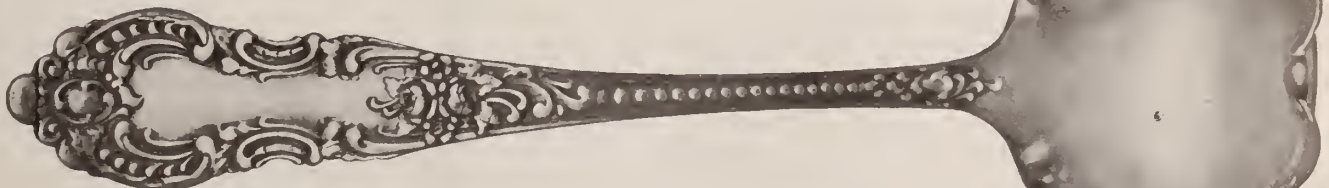

Made by J. B. & S. M. KNOWLES CO.,  
PROVIDENCE, R. I.

Established 1852.

STERLING SILVER ONLY.



TRADE MARK

If the man I sell it to dies or moves away, all well and good; but if he stays, there will be trouble between him and me and between me and the case company.

I have sold filled cases from the very beginning of that industry, and have now in the pockets of my customers filled cases that I sold over 20 years ago, and I venture to say that there is to-day more gold in those old cases than in many new ones that are now warranted for 20 years.

To show you the difficulty the retail trade is laboring under at the present time I will cite an actual experience: About six years ago I sold five 20-year cases to five young men, relatives and friends living in the same neighborhood. Every one of these cases wore off and had to be exchanged. They were made by two of the leading factories, and I am quite ready to acknowledge that the exchange was made cheerfully and without squirming. Yet, how do I stand in that neighborhood? Will these young men send their friends to me to buy watches?

Now to your special questions. No. 1—When I sell to a man a 14k. case, 25 years, he expects to wear such a case for that time. He won't allow me to substitute an inferior one. He, of course, cannot claim a case after the original 25 years have rolled by. This also answers your question 2. 3—It is my opinion that the case cannot be so repaired. 4—If I sell a case my customer expects me to stand by the guarantee without additional expense to him, and if I make about \$3 on a case I can't out of my own pocket pay \$4 to make good the factory's guarantee.

As I stated in the start, the only way to do is to put in enough gold and charge accordingly for the case. Yours truly,

FRED. NOTERMAN.

KEENE, N. H., Sept. 12, 1899.

Editor of THE JEWELERS' CIRCULAR:

In reply to yours of Sept. 8, will say that I think the customer would be better satisfied to receive a case as good as the original, and if cases were made as good as they should be there would be little for the makers to complain of. In my 20 years' experience I have had only one case to return to the makers. That case showed the base metal in about six or seven years in one place where the gold seemed to be thin, through no fault of the makers. They furnished a new case of the same grade without expense, requiring a receipt from the customer that he received it without any expense whatever. We have used only such cases as we believed to be the best, and our experience has been very satisfactory.

Very truly yours,  
W. E. WRIGHT.

AURORA, Ill., Sept. 12, 1899.

Editor of THE JEWELERS' CIRCULAR:

Your circular at hand relative to guaranteeing of filled cases. Will say that it is our opinion that if the case shows the base metal before the life of the guarantee has expired the manufacturer should repair the case and put it in condition to outlive the unexpired term. Should the case not live up to its guarantee another good plan would be to give rebate for the unexpired term of guarantee. He should not be expected to replace the poor case with one of the same length of guarantee as the old case, by no means, but one that would outlive the unexpired term of guarantee.

Yours truly,  
EGERMANN & SON.

(Series of Letters to be continued.)

### New York Credit Men Listen to Several Able Speeches on Commercial Topics.

An important meeting of the New York Credit Men's Association took place Wednesday evening last, at the rooms of the Drug Club, and as usual on these occasions, the 100 members present gathered together at an informal dinner preceding the meeting. At the conclusion of the dinner President Bartindale, with a few happy remarks, introduced as the first speaker of the evening Bird S. Coler, the Comptroller of Greater New York.

Comptroller Coler showed the members the relation of their work to the political body of the community by saying that a man honest in trade will be honest in politics, and then called attention to the necessity of business men and merchants taking more active interest in politics than they do. He said that he was in hearty sympathy with the purposes of the organization, as he was opposed to fraud and imposition of all kinds, and believed that the higher the credit of the individual unit of the business community, the higher will be the credit of the community as a whole. He asked the members to go a little outside their work and take a more active interest in the credit of New York, financial and social. He then briefly reviewed the progress recently made by the city, and also pointed at some of its shortcomings. He condemned those who slandered or vilified the city, as hurting the community, individually and collectively, and asked the members to tell the world, if necessary, the improvements that were being made, as well as the other advantages the metropolis possesses. When evils are discovered, he suggested that the people endeavor to remedy them and not go about pointing them out to every stranger. He concluded by again asking the members to take an interest in local affairs and guard the fair name of New York from slander.

Mr. Coler's remarks were received with great approval, and he was followed by Morris S. Wise, a referee in bankruptcy, of New York. Mr. Wise's remarks were principally upon the bankruptcy law and upon bankruptcy. He called attention to one inherent defect in the present statute, viz., it does not prevent a bankrupt who is guilty of fraud under certain circumstances from being discharged, and suggested an amendment to the law which would also provide for the punishment of fraudulent transfers of property. Another defect which Mr. Wise touched upon as existing in the present laws, was the diversity of the various State exemption laws, which give different degrees of exemption to bankrupts. Additional information on bankruptcy was given in the remarks of the following speaker, E. C. Brandenburg, who is connected with the Department of Justice at Washington. Then followed G. Waldo Smith, who talked upon the subject of "Canals," and who in turn was succeeded by Hugo Kanzler, who talked on the subject of credits, especially on the evils of dating. Next came a speech by W. A. H. Bogardus, which contained much general advice to the members, and was well received. The speech-making for the evening was concluded by a few brief remarks from ex-president Chas. Biggs.

WATCHES

WHO SAID WATCHES?

Ladies' Watches,  
Gentlemen's Watches,

Railroad Watches.

We Are the Largest Distributors of

Dueber-Hampden Watches

IN NEW YORK.



John H. Pierwood & Co.  
Watches. Chains. Diamonds. Jewelry.

No. 3 MAIDEN LANE, NEW YORK.

# THE DUEBER HERALD

THE ADVOCATE OF HONEST BUSINESS METHODS.  
 ✽ DEVOTED TO THE RETAIL JEWELRY TRADE. ✽

VOL. I.

CANTON, OHIO, NOVEMBER, 1899.

No. 9.

## TRUTHS.

You may hide Truth;

\* \* \*

You may cover it, disguise it, deny it.

\* \* \*

You may down it for a time—but only for a time; for, do what you will, Truth will prevail in the end.

\* \* \*

The Dueber-Hampden Works are the largest and best-appointed watch works in the world. That is Truth.

\* \* \*

The Dueber-Hampden Watch is the most accurate and reliable in the world, "The Best." That is Truth.

\* \* \*

The success of the Dueber-Hampden Works, the success of the Dueber-Hampden Watch is unequalled. That is Truth.

\* \* \*

And Truth will prevail.

## LABOR AND MACHINERY.

To produce a perfect watch, perfect labor and perfect machinery are necessary.

The attributes of the workmen must be skill, integrity and the ability to fill perfectly the positions assigned to them. The machinery must be modern, practicable and perfectly adapted to their requirements.

All this, the reader will say, is self evident. True; but how many watch factories are there who can boast of perfect labor and perfect machinery?

The management of the Dueber-Hampden Works have made a study of the labor and machinery questions, with the result that their skilled labor and their machinery represent the very best obtainable.

So far do they carry care and discrimination, that no help is hired without passing muster before John C. Dueber personally, the President of the Dueber-Hampden Works; no machinery is made or purchased, be it ever so trivial, without Mr. Dueber's sanction, and not one is there in the vast army of hands, from foreman to errand-boy, with whom Mr. Dueber is not personally acquainted.

Therefore it is that the high order of talent employed by the Dueber-Hampden factories cannot be equaled by any or all of their competitors.

## CASE-TALK.

Over thirty-five years ago the first Dueber watch case was born.

\* \* \*

It triumphed. Then, with every new case, the triumph of Dueber goods grew more pronounced.

\* \* \*

Why? Because "What is worth doing, is worth doing well" is the motto under which Dueber goods are made.

\* \* \*

To-day, despite the tremendous growth of the enterprise, the same careful and rigid inspection is made of all Dueber goods, as when every case was passed upon by John C. Dueber himself.

\* \* \*

Dueber goods are: **Term and Stamp True.**

Alvorado, Texas.  
 I am a chief dispatcher at this station for the M. K. & T. R. R., and am the possessor of one of your new 17-jewel watches named "New Railway." It gives perfect satisfaction and is one of the best timekeepers on the road.  
 O. E. MAER.

Let Columbia time  
 Her Progress by the  
 Dueber-Hampden Watch.

DUEBER  
 WATCH  
 CASES  
 make trade and  
 hold it.

# Simplicity of Construction

combined with superior workmanship, is what makes the

## Trenton Watches

the most reliable of all low-priced movements.



12-Size Trenton, 7 Jewels, Stem-Winding, Lever-Setting, Hunting, (open face) without second hand. Supplied in Silver and 5-year Gold-Filled Cases.

The "Trenton," for the price, far surpasses any movement ever placed upon the market.

SEND FOR PRICE-LIST.

**The Trenton Watch Co.,**  
Trenton, N. J.

### Decision of Interest to Jewelers.

#### Superior Court of Pennsylvania Decides Jeweler Has No Right to Sell His Goods at Auction Without Authority.

PHILADELPHIA, Pa., Nov. 24.—An interesting question affecting the right of manufacturing and retail jewelers to dispose of their goods by auction was settled on Wednesday by Judge Beaver, of the Superior Court of Pennsylvania, affirming the judgment of the Quarter Sessions Court of Lebanon County in the case of the Commonwealth vs. Percival.

E. P. Percival is a jeweler and watchmaker with a large establishment at 221 N. 8th St., Philadelphia. He is widely known in the trade throughout the city and State. The prosecution was brought at the instance of manufacturing and retail jewelers.

Percival was arrested in August, 1898, for selling watches at private sale and public auction at Mount Gretna, Pa. He was convicted of violating the act of Assembly of April 2, 1830, regulating such sales without authority. Percival alleged that he had not violated the act, because he was a manufacturer of the watches and, therefore, had the right to sell them at auction. The defense also alleged that the act was unconstitutional. After elaborate argument Judge Beaver handed down the following decision:

"The jury in this case returned, under the instruction of the court below, the following special verdict: 'The defendant is a resident of the city of Philadelphia, in the State of Pennsylvania, is engaged and has his place of business in said city—No. 221 N. Eighth St.—where he carries on a business of a jeweler and watchmaker, purchases the movements, dials, springs, hands and cases separately, assembles these parts and puts them into a marketable condition as watches. During the Summer season he goes from place to place selling these watches privately and by auction, and in the course of his travels he visited Mount Gretna, in the county of Lebanon, on August 18, 1898, where he sold several of these watches at private sale and by outcry to competitive bidders at public auction; that the several watches herewith brought into court and made a part of this special verdict are similar to the watches sold by him on the above mentioned date at Mount Gretna. If under the above facts and act of Assembly appeared April 2, 1830, which is made a part of the verdict, the court is of the opinion that the above act of Assembly is unconstitutional and that the defendant has violated any of the provisions thereof, then we find the defendant guilty in manner and form as he stands indicted, otherwise not guilty and the county to pay the costs of prosecution.'

"Upon consideration of these facts the court below entered judgment for the Commonwealth, and the defendant was duly sentenced.

"Two questions are raised by the appellant. First, that he has not violated the act, because he is a manufacturer of goods, wares and mer-

chandise within this Commonwealth, and has, therefore, a right under the act to expose the products of his own manufacture to sale by vendue or outcry; and, second, that the act is unconstitutional.

"A manufacturer, as defined by Bouvier, is 'one engaged in the business of working raw materials into wares suitable for use.' In the case under consideration, the defendant assembled and put together the various parts of a watch. He made none of them. He expended no labor upon them to fit them for their place. He purchased no part of any of them as raw material. Each particular part of the finished watch was in itself a finished product. Much less is he a manufacturer in contemplation of the act under consideration.

"The contention as to the unconstitutionality of the law is that it offends against the Federal Constitution in regard to inter-state commerce. Legislation in regard to hawkers and peddlers began very early in the history of our Commonwealth. The preamble to the act of March 30, 1784, reads: 'Whereas many idle and vagrant persons may come into this State and under pretense of being workers or peddlers, may greatly impose upon many persons in the quality and price of goods, and also may commit felonies. For preventing such inconveniences and evil practices and to the end no persons may be permitted to follow the business of hawkers or peddlers within this State but those who are of known honesty and civil behavior.'

"There seems to have been in 1830 a return of the apprehension of the Legislature as to the evils which might follow indiscriminate hawking and peddling, and therefore the act of Feb. 6, 1830, relating to this and clock peddlers and the act under consideration for regulating hawkers and peddlers, passed the same year. It is very evident from a consideration of the preamble of the act of 1784, and of the acts themselves, that the Legislature had in mind the regulating of hawking and peddling, under the police power of the State which rested in it. The appellant's argument is specially directed against the proviso of the second section, which is 'That nothing contained in the act shall prohibit the citizens of this Commonwealth who may manufacture goods, wares or merchandise within this Commonwealth from vendue or exposing the same to sale in the same manner as if said act had not been passed into a law.' If this promise stood as independent legislation there would be some force in the argument of the appellant, but it is to be observed that the proviso is in favor of the citizens of the Commonwealth, and it is easy to see that, in view of the evil to be remedied and of the remedy which the legislature had in mind, the safety of the people would be considered as less endangered at the hands of our own citizens than of irresponsible hawkers and peddlers who might come, no one knew whence and go no one knew whither. If the defendant had been a manufacturer within, and an effort had been made to impose the penalty provided in the section for the sale of goods manufactured without the Commonwealth the question raised by the appellant would have been closer, but such is not the case, and even if the contention were well founded and we were disposed to assent to it, the appellant could in no wise be benefited for; if the proviso be swept away, he has nothing whatever to stand upon. Admitting that the proviso sins against the provisions of the Federal Constitution in regard to inter-state commerce it might be held to be unconstitutional and the remainder of the act valid.

"If it were necessary in this case to invoke the aid of the principal, we would do so without hesitation. So far as the rights of the appellant, therefore, are concerned it is not necessary for

WATCHES OF PRECISION.

## MATHEY BROS., MATHEZ & CO.,

WATCHES DEMAGNETIZED.



MANUFACTURERS AND IMPORTERS OF

Superior Plain and Complicated

### WATCHES AND MOVEMENTS.

Small Lever Watches a Specialty.



10 SIZE MOVEMENTS.

BRASSUS, SWITZERLAND.

21 & 23 MAIDEN LANE, N. Y.

10 SIZE SPLITS.





## “Elf”

*A Special Line of Hand-Engraved,  
Bassine, Hunting-Case Watches—*

*The Same Designs  
in Open Face.*

*New This Season!*

THE Tiniest, Daintiest Line of Hunting Cases on the market for the Christmas season. The movement is the well known “Elf,” nickel damaskeened, with 12 jewels. The cases, of 14k. solid gold, with a 25-year guarantee, are HAND-ENGRAVED—the very highest class of work that can be put on them. The Hunting-Case feature was never more exquisitely brought out, and every watch in the line is sure to command the attention and admiration of all holiday shoppers. We have taken especial care to have the line very choice, and in such variety and range of prices that every taste and purse may

be met—the prices being very much lower than it could be supposed these watches could be sold for, and yet there is a good profit for the dealer.

Nothing quite so fills the bill for a Christmas gift as a dainty, attractive watch. It's always in style—always in the best of taste—always a most welcome present.

Be sure you have a sufficient stock to meet your Christmas demands. We have as full a stock of these watches as it was possible to make, but the demand for this class of goods is so unprecedented, as all dealers know, that the stock won't last long.

*The New England Watch Co.*  
*WATERBURY, CONNECTICUT.*

# Exquisite Enamel Watches

FOR THE HOLIDAYS.

THE FINEST ASSORTMENT OF DAINTY GOLD AND SILVER ENAMELED WATCHES, ARTISTICALLY DECORATED, FULL JEWELLED LEVER AND CYLINDER ESCAPEMENTS.

Quality Warranted.

## HIPP. DIDISHEIM & BRO.,

54 MAIDEN LANE, NEW YORK.

CHICAGO OFFICE, CHAMPLAIN BLDG.

us to pass specifically upon the question raised by him in regard to the constitutionality of the proviso of the second section of the act above quoted for that reason as already estimated, that, even if so declared it could not in any event relieve him.

"Upon consideration of the whole case we think the conviction was legally had and that the action of the court below in entering judgment upon the special verdict was proper. Judgment affirmed."

### Decisions as to Alleged Infringements on the "Marcella" Chain Patent.

Judge Colt, of the U. S. Circuit Court, at Boston, Mass., last week handed down decrees in the two suits brought by Lissauer & Co., New York, against A. H. Bliss & Co., North Attleboro, Mass. The actions, as already told in THE CIRCULAR, were upon infringement of the patent for the "Marcella" chain, and for unfair competition in trade. The decree relating to the unfair competition suit provides that the defendant, Anthony H. Bliss, his agents, workmen, etc., be perpetually enjoined and restrained from using the name "Cinderella" upon or in connection with any watch chain or chains, and from selling, keeping or offering for sale any watch chains bearing thereon the said name "Cinderella"; that the defendant is in like manner enjoined and restrained from making, purchasing, procuring or using cards or cardboard, cut or slit like those alleged to be copied from Lissauer & Co.'s chain cards, upon which to hang, drape or arrange watch chains. In addition the defendant is enjoined and restrained from using or employing portraits or similar pictures upon cards on which the chains are arranged and offered for sale, or in advertisements in the trade journals, circulars, etc. Finally the defendant is enjoined and restrained from doing any act intended to promote or enable unfair competition, or the substitution or sale of his chains for the complainants' chains.

In the suit relating to the infringement of the design patent for the "Marcella" chain, the Court awards damages and profits to Lissauer & Co. and further decrees as follows:

"That United States Letters Patent No. 31,064, granted June 27, 1899, to the complainants, Lissauer & Co., for a new and original design for a watch chain and necklace, being the Letters Patent in suit, are good and valid Letters Patent; that the title thereto and to the invention described and claimed therein is vested in the complainants; that the complainants are the owners of the entire right to recover damages and profits from all infringers of said Letters Patent; that the defendant has infringed upon said Letters Patent, and upon the exclusive rights of the complainants under the same, by the manufacture, use and sale of chains, containing and employing the invention described and claimed in said Letters Patent, and among others known and designated as Cinderella chains.

"That a perpetual injunction be issued herein against the said defendant, his officers, servants, agents, attorneys, employes, workmen and confederates, and each and every one of them, perpetually enjoining and restraining them, and each of them, from directly or indirectly making, constructing, using or vending, or in anywise counterfeiting or imitating the said invention, or any chains like or similar to those which the said defendant has heretofore made, used and sold, in infringement of said Letters Patent No. 31,064."

D. O. Herndon, jewelry auctioneer, after closing a sale in Grand Island, Neb., was compelled to go to his home in Mendon, Mo., on account of illness.

The  
**Leader**

...IN...  
HIGH GRADE  
WATCHES

—IS THE—

## VACHERON & CONSTANTIN,

GENEVA, SWITZERLAND.

FIRST in { Quality,  
Adjustment,  
Durability,  
Style.

FITS ALL SIZES  
OF AMERICAN  
CASES.

{ NEW GRADES  
SIZES  
IMPROVEMENTS.



{ SPECIAL GRADES  
FOR RAILROAD  
MEN.



**EDMOND E. ROBERT,** 3 Maiden Lane,  
SOLE AGENT,

**New York.**

# WALTHAM WATCHES

*are the best and best-known watches  
in the world.*



Ralph Waldo Emerson, in his Essay on Eloquence said in speaking of a man whom he described as a Godsend to his town. "He is put together like a Waltham Watch."





# A. & B.

## HEADQUARTERS

FOR

## Waltham Watches

EVERY GRADE.

## AVERY & BROWN,

68 Nassau St., New York.

*James D. Hughes,*  
*Wholesale Jeweler*

*Successor to F. W. Sewall,*

*728 Chestnut Street,*

*Second Floor.*

*Philadelphia.*

### Frank Bailey Kills His Brother, Then Himself.

DETROIT, Mich., Nov. 24.—The village of Stockbridge was excited yesterday by a double tragedy, the victims being Frank and George Bailey, jewelry and bicycle dealers in that town. George entered the store from the rear at 4 o'clock yesterday afternoon, and Frank, who had partially disrobed, shot him from the rear, the bullet passing through the neck. The murderer then shot himself between the eyes with the rifle and died almost instantly. He left a letter giving minute directions for the funeral arrangements, but gave no reason for his crime. The authorities can find no motive except insanity. This theory is borne out by the fact that the murderer had been under the physician's care for a year because of an affection of the mind. They conducted a successful business and were always of a friendly disposition towards each other and the citizens of the village.

### Meeting of the Creditors of John T. Roberts.

LISBON, O., Nov. 24.—At a meeting of the creditors of John T. Roberts, bankrupt jeweler, East Liverpool, George E. Davidson was elected trustee. Mr. Roberts, on being examined, said that the jewelry store in East Liverpool is run in the name of M. E. Roberts, his wife; that she became owner of the store Jan. 16, 1899, and that on and before that date he had owned the store; that the transfer was made by him to his wife in part payment

of a chattel mortgage of \$1,000 which she held against the property.

The goods turned over to her were appraised at \$700, and she still remains a creditor for \$300 and the interest on the same. The chattel mortgage, Mr. Roberts testified, was executed to secure the payment to his wife of the \$1,000 he owed her for labor at the rate of \$6 per week, she having helped him in the store. He claimed that no person held any property in trust for him and that none of his property was in anybody's name.

### New Trial of A. F. Lynch, Charged with Murder.

MAUSTON, Wis., Nov. 21.—The most important case on the calendar for trial in the Juneau county term of the Circuit Court is that of the State of Wisconsin vs. A. F. Lynch, a jeweler of Tomah, who was charged with the murder of William Hetzel, aged 70 years, father of his divorced wife, whom he shot and killed in Tomah, July, 1898. Hetzel was charged by Lynch to be the author of the latter's domestic troubles and the defense set up will be a plea of insanity. When the case first came to trial in Mauston, in April, 1899, on a change of venue the issue of insanity was tried first and resulted in a disagreement of the jury.

Caleb B. Martin, a jeweler of Butler county, Ky., filed a petition in bankruptcy in the Federal court in Owensboro, Nov. 21. Assets \$110, liabilities \$1,734.93. His creditors reside at Morgantown, Hartford and Beaver Dam.

# "OMEGA" WATCHES.

NONE BETTER MADE. OVER 1,000,000 IN USE.



Pendant Set. 12, 14 and 16 Size.  
Made in Gun Metal, Silver, Gold-Filled  
and Solid Gold Cases.

Send for Price-List.

Our 10 Ligne O. F. "Omegas," full Jeweled Anchor Movements, in 14 K., plain polished or enameled cases, are "just the thing" for the Holiday trade.

Our 12 Size "Omegas," made in 7 and 15 Jewel grades, and Our 16 Size "Omegas," made in 6 different grades—7 Jewels to 21 Jewels—are particularly desirable where fine timepieces are desired.

The "Omegas" are sold only to the regular trade, so no prices will be found in any publication whatever, thereby insuring a good profit.

**Edmond E. Robert, 3 Maiden Lane, N. Y.;**  
**Cross & Beguelin, 17 Maiden Lane, N. Y.,**

SOLE SELLING AGENTS.

**A. R. Justice & Co. and Riverton Silver Co. Rehabilitated.**

PHILADELPHIA, Pa., Nov. 23.—A. R. Justice & Co. and the Riverton Silver Co., jewelers and silversmiths, doing business on Chestnut St. near 8th St., both of which firms failed April 18 last and were declared bankrupts, have now recovered from their misfortunes, and have filed a petition in the United States District Court praying that the Court dismiss for non-prosecution the petition of Albert L. Silberstein *et al.* which prayed for an adjudication in bankruptcy against the firms. The Court has appointed Tuesday, Dec. 12, 1899, as the day for the hearing and all known creditors and persons in interest will be summoned to show cause, if any, why the petition should not be granted.

Samuel H. Kirkpatrick is acting as attorney for the firms' interests. The members of the firms, who are highly respected and well liked in the local trade, are Alfred R. Justice, F. Millward Justice and C. Arthur Roberts, general partners, and Fearay Hale, special partner.

**New York Members to Entertain Philadelphia Members of the Philadelphia Jewelers' Club.**

PHILADELPHIA, Pa., Nov. 25.—The New York members of the Philadelphia Jewelers' Club have made arrangements to entertain the local members with a theater party and banquet in New York on Saturday, Jan. 6. Charles F. Duffy, of Enos Richardson & Co.; Newton B. Elting, of Jung, Staiger & Klitz, and Charles Le B. Snedeker have been appointed a committee to perfect the details. Mr. Duffy is chairman of the committee. This will be the first time in the history of the Jewelers' Club that the members have been entertained by the New York contingent and a royal good time is expected.

Local jewelers are enthusiastic over the

invitation and more than 50 have already promised to be present. Although all the details have not yet been completed, it is practically settled that the Philadelphians will take the 2 o'clock train Saturday afternoon, Jan. 6, and will be met at the ferry by the New Yorkers. They will most likely register at The Arena. From there they will be taken to Koster & Bial's and back again to The Arena, where the banquet is to be served. Notices have already been sent out by William Quinn, acting secretary of the Jewelers' Club.

**The Removal of Barbour Silver Co. to Meriden.**

HARTFORD, Conn., Nov. 25.—Some time ago it was announced that the Barbour Silver Co., whose factory is included in the International Silver Co., would be transferred from Hartford to Meriden. It is now thought that this transfer will take place about Jan. 1. One of the officials of the company stated this week that it is now the busiest season and no removal can be contemplated while the season lasts. After the Christmas trade is supplied the change will be considered and operations will begin. The company have over 200 employees.

**Louis Haase's Trunks Robbed of Their Best Contents.**

INDIANAPOLIS, Ind., Nov. 24.—Last night burglars entered the jewelry store of Louis Haase, 17½ S. Meridian St., and carried off \$2,000 worth of gold goods. Mr. Haase does a small jobbing business and had left his three trunks, packed for the road, in his rooms. Everything in the trunks was gone over, the plated goods thrown aside and the gold goods carried off. A vain attempt was made to break into the safe. Less than a year ago Haase suffered a similar loss in the same way. No clue to the robbers has been discovered.

**The Discovery of Corundum Deposits in Canada.**

MONTREAL, Can., Nov. 18.—The discovery of large deposits of corundum in Canada in fairly pure condition has given rise to the hope that its more precious relations, the ruby and the sapphire, might also be found in the same region, and this has led to considerable investigation. In some places corundum has been found which shows plainly the blue line of the sapphire, but as yet no real gems have been discovered. The deposits of corundum in Ontario, however, are of such value, and are so easily worked, that it is hoped this valuable abrasive material will soon be placed upon the market at a much more reasonable price than now obtains. The deposits of Ontario lie north of Kingston and cover a large area. The corundum occurs along with mica and other substances. It is tapped up into powder, and separated from the rest of the rock by washing, its weight being much greater than that of the other constituents of the rock.

The deposits have only recently been discovered, and are as yet almost undeveloped. The Massey-Harris Co., however, have now started to develop some of the deposits, which they have purchased from the Government, and these mines will doubtless soon become a factor in the market. At present corundum is only mined in America in one place, in North Carolina, and even there very little has been accomplished. This deposit is found in the Appalachian mountain range, which runs through the eastern townships of Quebec, and, as the rock formation is the same in that place as in North Carolina, it is supposed that corundum will be found there also, although no discoveries have been made up to this date.

C. J. Hubbard, Ludlow, Vt., is preparing to add an optical department to his store.

# Gifts for Men

Gold Cigarette Cases,  
Gold Match Boxes,  
Gold Cigar Cutters,  
Gold Pocket Knives,

Ornamented with  
DIAMONDS  
and Precious Stones.



TRADE-MARK.

HIGH-CLASS NOVELTIES of all kinds in Gold and Silver,  
made handsomely, heavy and exclusively  
for the Jewelry Trade.

860 Broadway, N. Y.

42-46 Hill Street, Newark, N. J.

**Woods & Chatellier,**  
Gold and Silversmiths.

**DIAMONDS.**  
**Wm. S. Hedges & Co.,**  
 IMPORTERS OF  
**Diamonds and Precious Stones.**  
**DIAMOND JEWELRY.**  
**170 Broadway, New York.**  
26 Holborn Viaduct, London.

**SCHULZ & RUDOLPH,**

....Importers and Cutters of....

**..DIAMONDS..** .....AND OTHER....  
**PRECIOUS STONES.**

SOLE AGENTS FOR THE CELEBRATED

**JULES JÜRGENSEN WATCHES AND**  
**COPENHAGEN, CHRONOMETERS.**

**28 John and 65 Nassau St., New York.**

**MOUNT & WOODHULL,** FORMERLY WITH LATE FIRM OF  
..... IMPORTERS OF ..... **RANDEL, BAREMORE & BILLINGS,**

**Diamonds, Other Precious Stones, Pearls, Etc.,**  
**Makers of fine DIAMOND JEWELRY,**

**26 MAIDEN LANE (SOUTHWEST CORNER NASSAU STREET), NEW YORK.**

JOHN C. MOUNT.

ADDISON W. WOODHULL.

**RUBIES.**

**SAPPHIRES.**

**C. G. MALLIET & CO.,**

**EMERALDS.**

**14 MAIDEN LANE, N. Y.**

**DIAMONDS.**

**The Bowden Rings**

**ARE COMPLETE IN VARIETY, CORRECT  
 IN QUALITY AND PERFECT IN FINISH.  
 WE MAKE EVERY VARIETY OF FINGER  
 RINGS**

**J. B. BOWDEN & Co.,**

**1 MAIDEN LANE,**

**NEW YORK.**

**Precious Stones: London Market**

HATTON GARDEN, London, Eng.,  
 November 17, 1899.

*Diamonds.* Nothing has transpired as to any further advance in rough. American buying is, I imagine, practically at an end for the present. The effect of high prices in stones does not seriously influence the cost of jewelry in which small brilliants only are used.

News from Kimberley continues meager. An intermittent bombardment of the town has gone on for a week or two. The correspondents have been reticent (or the military censorship has made them appear so), but there is no doubt that the Boers have made a special mark of the DeBeers property, and it is evident considerable damage has been done. Details are, however, lacking and no definite intimation of the contemplated closing of the mines having been consummated has reached London.

The Ottos Kopje Diamond Mine has ceased working, owing to the shelling by the Boers, but the output is, as has previously been reported, of very little importance. This evening's cables confirm the news that the relief expedition, under the command of Lord Methuen, is nearing Kimberley. On the Stock Exchange DeBeers shares have risen to 29, 1½ higher than a week ago.

The largest London dealer in pearls (according to common repute) states that the all round advance in prices is equal to 100 per cent only in the last three or four years.

An 11-row pearl collar with five diamond bars was sold by Debenham's, yesterday, for £367. Other pearl necklaces and collars fetched £69, £60 and £58. Diamond pendants £65, £59 and £39. Studs and sleeve links £46. Half hoop brilliant ring £36, and a diamond and pearl marquise ring £35. R. F.

**Notes from London.**

*Christie's* sold a plain coffee pot of Queen Anne's reign at 67s. per oz., and old Irish potato ring, circa 1780, at 98s. per oz.

*Some Unique Ecclesiastical Silver* wares were shown after high mass, at the final services in the old Roman Catholic Church of St. Mary's, Moorfields, London. The chalice and gold goblets were presented to the church in 1820 by Pope Pius VII., and are stated to weigh 20 lbs. They are jeweled with diamonds, pearls and emeralds, and valued at over £7,000.

*Recent Fashionable Weddings* illustrate the present taste in jewelry in London. Diamonds and pearls, of course, predominate. Emeralds, rubies and sapphires are in evidence, but the noticeable feature is the increased use of the turquoise. An amethyst spray presented by the Duke of Westminster to the bride of Lord Longford is also an unusual item. Experts say that women's dress was never so artistic and expensive as at present. Valuable lace is, no doubt, partly responsible, but the increasing use of jewels in the main accounts for the enhanced cost. Jeweled glove buttons are to be noted in trade lists. R. F.

**Decision of Interest to Manufacturing Jewelers Using Steam Power.**

PROVIDENCE, R. I., Nov. 25.—Judge Stiness, before whom came the case of D. M. Watkins & Co. vs. Forrest Greene, asking for an injunction to restrain the respondent from depriving the complainants of the use of the steam and power in his building occupied by them, handed down a decision this week. This decision will be of interest to all jewelers leasing buildings for manufacturing purposes, since the Judge denied the petition of the complainants.

Judge Stiness said that he found that the injunction asked for was, in reality, a permanent injunction forcing the respondent to furnish the complainants with steam and power. He finds that the complainants' contention that the steam and power they particularize are by general custom considered the appurtenances of a building let for the manufacture of jewelry, is not borne out, it only seeming that this appears to be the case when a shop is hired by the month. Even then he finds that the lessor and lessee are accustomed to agree upon the question of steam and power in some manner.

In his opinion the statement of the respondent that he told the complainants he would furnish them with steam and power as long as a certain other tenant, who was also in the manufacturing jewelry business, remained in the building, but that thereafter he would charge the complainants \$10 a month extra for furnishing such steam and power, showed that the complainants were made to understand in this case that the steam and power were not to be accepted as appurtenances of the shop covered by the lease. He therefore denies the petition. The particulars of the case were given in last week's CIRCULAR.

**The Assignment of the Bicknall & Wood Company.**

PROVIDENCE, R. I., Nov. 25.—The Bicknall & Wood Co., the outgrowth of the old firm of Warren & Wood, established in this city some 24 years ago, assigned Thursday. It was stated that the assets of the Bicknall & Wood Co. would amount to about \$20,000 in round figures, and the liabilities to about \$15,000. At Bradstreet's it was stated that the firm have no rating in their Fall books.

C. Frank Parkhurst has been named as assignee of the firm. Mr. Parkhurst stated that it would be several days before he would be in a position to give out any statement regarding the condition of the firm, but that he would commence the duties of his position immediately. The cause given for the assignment is that the firm were no longer able to compete with the department stores. The firm were incorporated in July, 1898, with a capital stock of \$20,000, and with Frank J. Bicknall, George H. Wood and Stephen B. Brown as the incorporators. This firm were organized after the liquidation of the Wood, Bicknall & Potter Co., who were the outgrowth of the firm of Wood, Bicknall & Potter, who succeeded Warren & Wood. It is understood that New York parties who have furnished stock are the heaviest creditors.

ESTABLISHED 1840.

**Chester Billings & Son,**

Successors to **RANDEL, BAREMORE & BILLINGS,**

IMPORTERS OF

1840 RANDEL & BAREMORE.  
1866 RANDEL, BAREMORE & CO.  
1880 RANDEL, BAREMORE & BILLINGS.

**DIAMONDS**

OTHER PRECIOUS STONES AND PEARLS.

58 Nassau Street,  
29 Maiden Lane, 22 Holborn Viaduct,  
NEW YORK. LONDON, E. C.

✻ **DIAMOND JEWELRY.** ✻

*Oppenheimer Bros. & Veith,*

*Importers and Cutters of*

**Diamonds**

*Dealers in*

**Watches,**

*Cor. Nassau and John Streets,*

*(PRESCOTT BUILDING.)*

*....New York....*

*Amsterdam,  
2 Tulp Straat.*

*London,  
45 Holborn Viaduct.*

**Pearls**

**Opals**

Importers and Cutters **GOODFRIEND BROS.,** Precious and Imitation Stones

9-13 Maiden Lane, N. Y. 174 Weybosset St., Providence, R. I. 10 Rue Cadet, Paris.

TELEPHONE, 662 CORTLANDT.

**John F. Saunders,** Cutter and Importer of

**DIAMONDS** AND OTHER PRECIOUS STONES.

FINE PEARLS A SPECIALTY.

68 Nassau St., cor. John St., Sheldon Building, Room 16, NEW YORK.

**CASH OFFERS.**

If at any time you have offered to you by your customers any Jewelry containing diamonds, pearls or other precious stones, and you do not care to buy them yourself, send them to us and we will submit an IMMEDIATE CASH OFFER. Trade and Bank References if desired. Established 1880. Correspondence solicited.

**CHARLES S. CROSSMAN & CO.,**  
3 Maiden Lane, New York.

When selecting your stock see that the 14K. GOLD-FILLED CASES are stamped



... WARRANTED FOR 25 YEARS ...

## PEARLS.

### Our Experience

in purchasing goods simplifies matters for the discriminating buyer who purchases of us.

He will find exactly the goods he needs, in assortments large enough to admit of careful and successful selection.

### Alfred H. Smith & Co.,

182 Broadway, N. Y.

CHICAGO.

LONDON.

## DIAMONDS

And Other Precious Stones.

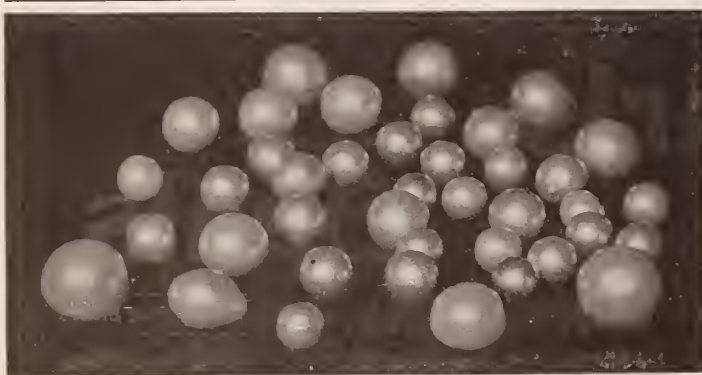

"The Pearl House."

We have no salesmen; call or write.

**EISENMANN BROS.,**

PARIS, 3 Rue St. Georges.

21 & 23 MAIDEN LANE, NEW YORK.

## Rubies and Emeralds.

BYRON L. STRASBURGER & CO.,

Watches and Diamonds,

17 MAIDEN LANE,

NEW YORK.

### The Sigler Diamond Robbery.

The Police Trying to Get on the Track of the Trio of Thieves.

CLEVELAND, O., Nov. 26.—L. M. Sigler, of Sigler Bros. Co., from whose business place a box containing \$18,000 worth of diamonds was stolen recently, received word from Pittsburgh, Pa., Friday night that a man had been captured in that city while in the act of making away with a tray containing \$6,000 worth of diamonds from A. E. Siedle's jewelry store. The Cleveland police authorities were also notified and asked to send someone to Pittsburgh to identify the man if he should prove to be the one wanted in Cleveland for the Sigler robbery. Chief Corner told THE CIRCULAR reporter he would not send a man to Pittsburgh, as the Pittsburgh people had a good case to hold their prisoner, and he would wait for a photograph.

Both Chief Corner and Mr. Sigler expressed the opinion that the Pittsburgh robber would prove to be another man than the one wanted in Cleveland; they did not think the Cleveland thief would do another job of the same kind in so short a time nor so near the field of his first exploit. Mr. Sigler has had several long conferences with Chief Corner and Captain of Detectives Lohrer in regard to the robbery here. None of the parties to the conferences would tell anything of their import, but Mr. Sigler said they were important. Chief Corner said the police had been unable to gain any trace of the robbers. In spite of this denial, it is believed that the local police have clues that have placed them on the track of the Sigler robbers.

Trio of Thieves Boldly Try to Rob the Store of A. E. Siedle.

PITTSBURGH, Pa., Nov. 25.—The sensation of the day is the attempted \$6,000 diamond robbery, which occurred last night at 6 o'clock. The intended victim was A. E. Siedle, who is conducting an auction sale on a large scale at 507 Market St. Robert Miller, a clerk, was in charge of the store, assisted by the colored porter, Joseph Burgess. Three men were implicated in the robbery. The first one entered the store and engaged Mr. Miller in conversation, and later the second entered and talked to Burgess. While the quartet were engaged with the clerk at the extreme end of the store, the third and most active partner entered and stood near the show window. He opened the window and took out the tray containing 24 diamond rings. Miller's suspicions had been excited and he saw the movement. The confederate grabbed Miller, who broke after the thief, and the second man tried to trip him.

An exciting chase ensued, and the Fifth Ave. portion of the city was soon in a state of wild commotion. The thief was finally run down on board a Fort Pitt St. car by an active citizen who was aided by Detective McGovern. The thief, who gave his name first as James Robinson, later as Jack Rollins, was arrested. He is evidently a professional, as he was equipped with a large black bag which he wore under his overcoat in a professional man-



ner. The gems were found in the bag, and 23 were recovered. The missing one, valued at \$200, was picked up by a bystander. The plot would have been successful if Robinson's confederates had rendered him more able assistance. They escaped, but the police have good descriptions of them. Rollins is thought to be one of those implicated in the recent Sigler robbery in Cleveland, and the Cleveland police are expected here to-day. Rollins was finely dressed, his garments bore the trade-mark of leading New York clothiers and were marked "J. R."

Roger O'Mara, superintendent of the bureau of detectives, to-day identified the man who attempted to rob A. E. Siedle's store as being James Reilly, a noted diamond thief, whose picture is in the rogues' gallery at Philadelphia, where he was arrested in 1888 on a charge of conspiracy. Word has been sent to all prominent cities of his capture. He was wearing a lot of new jewelry thought to be stolen. The tray of diamonds was valued at \$6,000.

Robinson is young, good-looking and smooth shaven. He and his two confederates were all well dressed. The arrested man was examined by the Bertillon system and it was discovered that he tallied with the description of James Reilly, alias John Richards, alias Ritchie, who was arrested Jan. 14, 1893, in Philadelphia, for conspiracy. He was born in St. Paul and is a peddler. He is 30 years of age, 5 feet 6½ inches in height, weighs 132½ pounds, has a Roman nose, scar on the cheek bone under left eye, is dark, wears good clothes, had \$50 and a new gold watch and chain, and a ticket from New York to Buffalo. He has a Jewish cast of countenance. The prisoner, last night, said his name was James Robinson. Later, he said he was Jack Rollins, a clerk, of Cincinnati. To-day he told Superintendent O'Mara that his name was Wallingford, and that he was a Canadian. Cincinnati and Philadelphia police have been telegraphed for.

**Utica.**

The retailers are all buying more goods this year for the holiday business than they have for several years back.

Police Sergeant Corrou went last week to Syracuse, where he arrested J. A. Goulson, spectacle peddler, who, it is alleged, swindled several women out of old gold for pairs of cheap spectacles.

**A Great Banquet Coming.**

**Arrangements for the Forthcoming Banquet of the Jewelers' Association and Board of Trade.**

The Jewelers' Association and Board of Trade will have a banquet on Jan. 23, 1900, at the Hotel Waldorf-Astoria, New York. This banquet will be the first since the New York Jewelers' Association and the New York Jewelers' Board of Trade combined into the present organization, and it was decided upon at the last monthly meeting of the board of directors. President A. K. Sloan was then authorized to appoint a banquet committee to take charge of the work, and he has appointed over 40 gentlemen, representing every line in the jewelry trade, who have agreed to work to make the occasion a momentous one. The committee held their first meeting Monday. From the character and members of this committee, the success of the banquet is already assured, and it is confidently expected that from 400 to 500 guests and members will participate.

Every effort will be made to excel in this all other banquets of both associations. For this purpose it has been decided upon to obtain the most prominent and renowned speakers possible. These speakers will, if nothing intervenes, be men of national reputation. One of the occasions of the banquet is to commemorate the combination of the two organizations, and also the fact that the Jewelers' Association and Board of Trade is to-day one of the largest mercantile bodies of its kind in the United States. Owing to the number that will participate it has been decided that the banquet will be held in the ball room of the Waldorf-Astoria, as this is one of the few places in the city that would meet the requirements of the occasion. The general committee who will take charge of affairs and number in all 43, met for the first time Monday and fixed the date and place of the banquet. They will work in the following sub-committees: Committee on banquet, committee on speakers, reception committee and committee on printing and souvenirs. The reception committee is the largest of these committees and numbers 25. The following is a list of the members on the separate committees:

*Banquet Committee.*—Oliver G. Fessenden, chairman; Geo. E. Fahys, Joseph B.

OTTO K. TREIBS.

PAUL E. TREIBS.

**TREIBS BROS.,**

68 Nassau St.,

New York.

CUTTERS AND IMPORTERS OF

**Opals.**

F. E. TREIBS,

Oberstein,

Germany.

ESTABLISHED 1842.

HERMANN TREIBS.

ALBERT TREIBS.

EMIL TREIBS.

**Survival of the Fittest.**

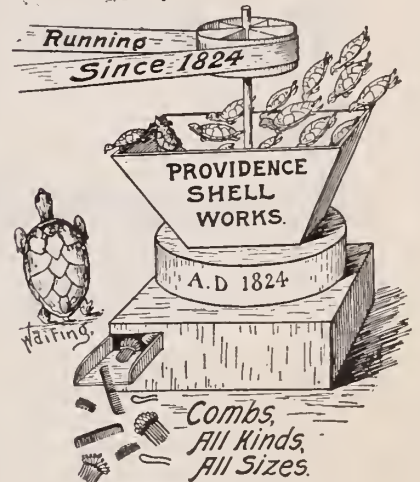

POTTER'S COMB FACTORY,  
PROVIDENCE, R. I.

**We Grind for You,  
Send along your Work.**

ESTABLISHED 1840  
TRADE MARK  
**SIMONS BROS. & CO.**  
SILVERSMITHS,  
JEWELERS.  
PHILA. NEW YORK CHICAGO  
MAKERS OF GOLD AND SILVER THIMBLES.

CATSEYES | SAPPHIRES | DIAMONDS | RUBIES | EMERALDS | PEARLS | PEARL NECKS | PEARL ROPES

**PEARLS, DRILLED AND UNDRILLED.  
PEARL ROPES, NECKS and COLLARETTES.**

**We are buyers of American Pearls.**

LONDON: 19-20 Holborn Viaduct. **JOSEPH FRANKEL'S SONS,** 68 Nassau Street, NEW YORK.

TELEPHONE, 3899 CORTLANDT.

FANCY COLORED DIAMONDS and GEMS in PEARLS and PRECIOUS STONES.

OLIVINES  
OPALS  
RUBIES  
SCIENTIFIC

Pearl Collarettes, mounted with Diamond Bars.

Bowden, Harry H. Bliss, Samuel H. Levy, Wm. I. Rosenfield.

*Speakers' Committee.*—Ludwig Nissen, chairman; Fred'k H. Larter, Geo. W. Shiebler, H. Blanchard Dominick, Geo. W. Street, Leopold Stern, Alfred H. Smith.

*Reception Committee.*—C. G. Alford, chairman; Geo. H. Cahoon, Clarence Breckenridge, Ira Barrows, Edwin R. Crippen, Henry Untermeyer, Chas. F. Wood, Jas. E. Spencer, Luther Hyde, Courtland E. Hastings, Wm. H. Ball, C. C. Champenois, David J. Frankel, Jno. T. Howard, David C. Townsend, Horace D. Sherrill, Wm. F. Dorflinger, David Kaiser, Stephen Avery, W. L. Thompson, Seth E. Thomas, Julius Lebkuecher, Henry B. Billings, Fred H. Webster, Nicholas Geoffroy.

*Printing and Souvenirs.*—Leo Wormser, chairman; Jno. C. Day, Alfred Krower, Jno. L. Shepherd.

#### Death of Charles R. Birch.

COOPERSTOWN, N. Y., Nov. 27.—Chas. R. Birch, for many years the leading retail jeweler of this town, died Sunday. Mr. Birch had been ill for over a year. For more than 40 years he had been identified with the jewelry industry of this town, and had learned the trade as a boy here with P. G. Tanner. He started in business for himself in 1860 and soon became the leading retail jeweler, a position which he continued to occupy until his ill health caused him to turn over his business to M. L. Lippit, about a year ago.

The deceased was one of the most prom-

inent citizens of the town, held many offices of trust and stood high in charitable and church work.

#### Importations at the Port of New York.

*Weeks Ended Nov. 25, 1898, and Nov. 24, 1899.*

	1898.	1899.
China, Glass and Earthen Ware:	\$85,806	\$86,016
China .....	30,437	12,832
Earthen ware .....	16,252	16,668
Glass ware .....	not recorded	21
Optical glass .....		
Instruments:		
Musical .....	14,001	12,077
Optical .....	11,139	10,004
Philosophical .....	2,973	1,400
Jewelry, etc.:		
Jewelry .....	8,228	6,675
Precious stones .....	134,242	211,791
Watches .....	21,021	25,442
Metals, etc.:		
Bronzes .....	583	4,019
Cutlery .....	21,195	23,387
Dutch metal .....	549	....
Plated ware .....	997	....
Platina .....	4,685	38,227
Silver ware .....	6,348	3,304
Miscellaneous:		
Alabaster ornaments .....	....	248
Amber .....	1,417	990
Clocks .....	4,775	7,302
Fancy goods .....	5,589	6,383
Fans .....	3,993	3,598
Ivory .....	29,774	23,183
Ivory, manufactures of.....	118	277
Marble, manufactures of.....	6,819	6,672
Statuary .....	1,150	9,401

#### Jewelers' Gold Bars Withdrawn and Exchanged.

*Week Ended Nov. 25, 1899.*

The U. S. Assay Office report:

Gold bars exchanged for gold coin.....	\$215,215.10
Gold bars paid depositors.....	47,875.47
Total .....	\$263,090.57

Of this the gold bars exchanged for gold coin is reported by the Sub-Treasury as follows:

Nov. 20 .....	\$26,526
Nov. 21 .....	30,575
Nov. 22 .....	54,587
Nov. 23 .....	46,748
Nov. 24 .....	15,982
Nov. 25 (closed).....	....
Total .....	\$174,418

#### New Turn in the Affairs of the Ontario Silverware Co.

MUNCIE, Ind., Nov. 23.—A new turn of affairs has arisen in the case of the Ontario Silverware Co., in which Ben. C. Bowman was appointed as receiver by Judge Leffler on the petition of members of the firm. Attorneys Brady and Warner, representing the interest of Edward Clark, the vice-president and general manager of the company, a son of the deceased Dr. Clark, whose death is alleged to be the cause of the receivership, presented a motion Tuesday to set aside the receivership.

The claim upon which this motion was made is that a proper notice of the proceedings was not given to Clark, who is one of the members of the firm, as is required by law. Tuesday night the case was argued, but Judge Leffler voluntarily vacated the receivership and gave 10 days' time in which Leonard McGlashan, one of the members of the firm, who resides in Canada, can have a chance to appear and state his side of the case.

W. S. Quencer, Watertown, N. Y., has removed to handsome quarters at 5 Court St.

Ludy & Taylor, Cedar Rapids, Ia., held their holiday opening Nov. 25. The firm presented a gift to every customer and there was music all day.

## Diamonds and Precious Stones.

We have a very large stock of Diamonds and Precious Stones purchased far in advance of the season, at prices which to-day are cheap. As long as they last we will give our customers the benefit of our foresight.

Do not delay making your selection, for large as our stock is, it must soon be depleted by the unusual demands which are being made upon it.

### HAYDEN W. WHEELER & Co.,

TWO MAIDEN LANE, N. Y.

LONDON OFFICE, 50 HOLBORN VIADUCT.

**"Imitation Jewelry" Scheme that Looks Much Like a Green Goods Swindle.**

What is believed to be a variation of the green goods swindle that has been tried more than once was disclosed Monday when United States Commissioner Rowe, of Jersey City, held J. McAndrew, Bayonne, N. J., in \$2,500 bail to await examination. McAndrew purports to be a dealer in "imitation jewelry," but in his correspondence gives the impression that "imitation jewelry" is merely another name for "imitation money." He first sends out a circular headed "Barrels of Money," outlining his scheme, and then a letter in which he gives prices of his goods. In this letter he says:

"Dear Friend—We have a lot of imitation jewelry which you can dispose of very easily. The price \$1 is in each corner of the long green printed card each piece is put upon. These goods are gotten up so well that no one except an expert can tell the difference between them and the genuine. They are a perfect imitation of the real goods. After a while we will have some for sale, the selling price printed \$2, \$5 and \$10."

Those who write for a sample and enclose \$1 get a third letter in which is a cheap brass pin with a piece of green glass in it, attached to a white card edged with green, on which is printed in green ink on each corner, price \$1. This pin is attached to a crisp new \$1 Treasury note. The letter says:

"Dear Sir—Your letter of recent date containing \$1 received. We herewith enclose you a dollar sample of our imitation jewelry. You will notice that it is a very good imitation of the real article. We enclose a \$1 bill back to you as agreed. You can see that it is a fine imitation of the real article and will prove satisfactory we feel confident. If it does we shall expect a large order from you. If you do not care to make a trial start please let us know at once, then we can erase your name from our books. Awaiting your early reply, we are Yours truly,

"J. McAndrew."

**Jacob I. Kerns's Bravery Foils the Designs of Two Desperados.**

CURWENSVILLE, Pa., Nov. 22.—Saturday evening two men entered the store of Jacob I. Kerns and asked him to change a \$50 bill. Mr. Kerns went to his safe to look for the cash, when he was suddenly held up by a loaded revolver. He is an active and muscular man and seized the intruder and threw him to the floor. The other man ran out of the store, and while Mr. Kerns was pursuing him the chief miscreant got away.

**Gift Enterprise Operator Guilty of Promoting a Scheme of Chance.**

CLEVELAND, O., Nov. 25.—In Police Court, to-day, Mrs. Flora J. Burt, proprietress of the Globe Tea Co., was found guilty of promoting a scheme of chance. Mrs. Burt did a large business in selling cans of tea containing "prizes" of cheap jewelry. Her methods were exposed in THE CIRCULAR some time before the local authorities took any notice of them.

The Palamountain Co., recently incorporated, have taken charge of an old jewelry business in Charlotte, N. C., of the late J. C. Palamountain. The business will be continued at the old stand, under the name above stated, and under the management of B. A. Southerland, who had been with Mr. Palamountain for a number of years. The business is owned by B. A. Southerland and George N. Adams and Mrs. Etta C. Palamountain.

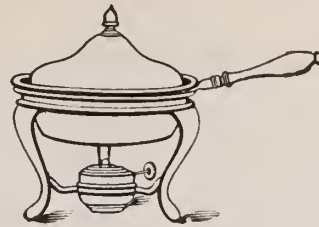

**WHY  
WAIT?**



The holiday trade promises to be the largest in the history of the country. We are far behind our orders, and any goods you may want for

**CHRISTMAS, ORDER NOW.**

Our new illustrated catalogue sent on application.

**S. STERNAU & CO.,**

Manufacturers of Metal Wares in Brass, Copper and Silver,  
204 Church Street, New York City.



**NOW WHEN YOU RECEIVE A SPECIAL ORDER...**

*for something you may not just have in stock—a fine watch or piece of jewelry or some loose diamonds—write or wire us. Goods by return express—you can depend on it. Many jewelers know this by experience. We should also like to demonstrate it to you.*

**HENRY FREUND & BRO.,**

11 Maiden Lane, NEW YORK.

ELK GOODS A SPECIALTY.

**S. C. POWELL, 51 & 53 MAIDEN LANE, NEW YORK.**

**STERLING SILVER NOVELTIES.**

CUTS ONE-HALF ACTUAL SIZE.



**File No. 1150.** Sterling Silver Handle, made up in twelve different pieces. **Price per doz., \$2.38.**

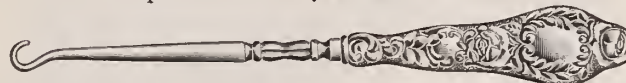

**Shoe Hook No. 430.** Sterling Silver Handle, mounted in twelve different pieces. **Price per doz., \$4.88.**



**Corn Knife No. 450.** Sterling Silver Handle, made in twelve different pieces. **Price per doz., \$6.75.**

Prices subject to 6 per cent discount. Send for our new catalogue.



**Cuticle No. 882.** Genuine Ebony, mounted with Sterling Silver ornaments, twelve different pieces. **Price per doz., \$2.63.**



## Our Traveling Representatives

Traveling representatives may consider these columns open for the publication of any news or items of interest regarding themselves or their confreres.

Lewis P. Cook, representing J. F. Fradley & Co., New York, was in the wreck of a B. & O. train near Cumberland, Md., last week while en route to Pittsburgh, Pa. Outside of a few splinters and a general shake up Mr. Cook escaped serious injury.

Among the travelers in Kansas City, Mo., last week were: J. M. Morrow, American Watch Case Co.; A. J. Hatfield, Jordan Cutlery Co.; M. Rosenberger, A. Wallach & Co.; Herman Kind, Graef & Schmidt; Lawrence H. Smith, Bippart & Co.

A representative gathering of commercial traveling men attended a banquet and reunion at the Winthrop Hotel, Meriden, Conn., Tuesday evening, Nov. 21. Among the 100 or more travelers present were: G. L. Sweet, of Simpson, Hall, Miller & Co.; John M. Harmon, of the International Silver Co., the latter an invited guest.

The jewelers of Portland, Ore., were interviewed the past week by the following traveling men: Geo. D. Lunt, Towle Mfg. Co., Chicago, Ill.; E. G. Haight, for W. B. Glidden, San Francisco, Cal.; E. B. Dana, Carter, Hastings & Howe, New York; H. L. Rothschild, Rothschild & Hadenfeldt, San Francisco, Cal.

Indianapolis, Ind., trade were visited last week by the following traveling representatives: Mortimer C. Adler, Byron L. Strasburger & Co.; Thomas Frothingham, T. G. Frothingham & Co.;

Charles Perret, Jules Racine & Co.; George A. Stockder, J. D. Bergen Co.; Herbert W. Van Houten, for C. Sydney Smith; Frank W. Trewin, Keystone Watch Case Co.

Traveling men in Boston, Mass., last week included: H. A. Friese, F. W. Lewis & Co.; Mr. Thompson, Elgin National Watch Co.; H. D. Sherrill, Sincock & Sherrill; A. W. Levy, Byron L. Strasburger & Co.; Matt. Stratton, Alling & Co.; Mr. Schwartz, Larter, Elcox & Co.; John Taylor, Krementz & Co.; Charles L. Power, Ludeke & Power; H. C. Barnum, Shafer & Douglas; Mr. Simpson, Riker Bros.

The following traveling salesmen passed through Detroit, Mich., last week: C. C. Offerman, William Smith & Co.; J. N. Beckwith, Beckwith & Grant; J. W. McClannin, the Wilcox Silver Plate Co.; E. C. McCarter, Lebkuecher & Co.; F. R. Krugler, the H. A. Kirby Co.; Frank L. Wood, Ludwig Nissen & Co.; H. A. Bliss, Gorham Mfg. Co.; F. L. Pettee, Waterbury Clock Co.; Fred Foster, Unger Bros., and E. C. Stone, Battin & Co.

Thursday, Dec. 28, has been selected as the date for the midwinter dinner and annual meeting of the Jewelry Travelers' Association of New England. Walter B. Snow, William C. Wales, W. Emory Clement and Fred H. Elliott, the committee in charge, are preparing a fine entertainment for the boys, and it is probable that the privilege will be accorded the members of inviting some of their customers to participate with them in the festivities of the occasion.

Traveling men in Omaha, Neb., the past week were: I. Guntzburger, Dattelbaum & Friedman; E. F. Strickland, Seth Thomas Clock Co.; Charles Fairbrother, B. K. Smith & Co.; H. L. Stanton, Chicago; Charles Garlich, Theodore Schrader & Co.; Jack Ashe, Sommer & Mills Co.; E. E. Spaulding, Bassett Jewelry Co.; De Lancey Stone, Shafer & Douglas; W. F. Adams, Simpson, Hall, Miller & Co.; H. C. Rowbotham, C. P. Goldsmith & Co.; M. Wolf, for Fred Kaufman; Mr. Henderson, Johnston Optical Co.; H. C. Barker, Mandeville, Carrow & Crane; S. L. Scott, M. F. Barger & Co.; E. W. Brannon, J. W. Reddall & Co.

Not many travelers visited Pittsburgh, Pa., last week. Among those who did were: George H.

Remington, Waite, Mathewson & Co.; John A. Abel, David Kaiser & Co.; Mr. Luther, Smith & Crosby; F. B. Lawton, Lawton-Sherman Co.; J. F. Dean, Reed & Barton; Walter S. Noon, W. F. Cory & Bro.; W. H. Gregory, Strobell & Crane; Abel King, I. Emrich & Co.; Mr. Barclay, Mauser Mfg. Co.; E. A. Reed, Reed & Barton; Frank W. Trewin, Keystone Watch Case Co.; Lewis P. Cook, J. F. Fradley & Co.; Leo Goldsmith; Mr. Lampert, Henry Zimmern & Co.; Emil Pick, Hammel, Riglander & Co.; Leo Henle, Sussfeld, Lorsch & Co.; A. L. Reach, F. H. Noble & Co.

Travelers visiting the trade in Louisville, Ky., last week were: Frank E. Wallis, Thomas W. Adams & Co.; I. Price, Byron L. Strasburger & Co.; Mr. Bunnell, Pittston Cut Glass Co.; Charles Lochner, Hayes Bros.; G. Hofman, the Ansonia Clock Co.; John E. Valk, N. H. White & Co.; Mr. Waugh, E. Kirstein's Sons Co.; J. C. Miller, the H. Keck Mfg. Co.; Zach A. Oppenheimer; D. L. Skutch, New Haven Clock Co.; Samuel Heller, L. Heller & Son; Charles Perret, Jules Racine & Co.; Robert B. Steele, J. B. Bowden & Co.; R. P. Coughlin, Wm. L. Gilbert Clock Co.; W. L. Baker, Hayden W. Wheeler & Co.; Frank L. Gibson, for Wm. Kinscherf; Thos. E. Rogers, Riker Bros.; Emanuel Jacobson, Jacobson Bros.; Frank E. Whitmarsh, Alvin Mfg. Co.

Among travelers in St. Louis, Mo., last week were: V. Hirsh, Hirsh & Hyman; Thomas E. Rogers, Riker Bros.; W. G. E. Pettes, A. Sartorius & Co.; C. P. Young, Wm. B. Kerr & Co.; G. W. Townsend, Kreis, Hubbard & Co.; De Witt A. Davidson, Wallach & Schiele; J. M. Morrow, American Watch Case Co.; J. Williams, for G. Armenia; Chas. Lochner, Hayes Bros.; L. W. Melcher, F. A. Hardy & Co.; A. H. Felix, for A. Wittnauer; E. C. McCarter, Lebkuecher & Co.; C. N. Perley, Alling & Co.; R. H. Stevens, Mabie, Todd & Bard; F. C. Winship, T. B. Clark & Co.; Geo. W. Bleecker, Martin, Copeland & Co.; I. Friedman, Zimmern, Rees & Co.; Louis Bernheim, Bernheim, Cohn & Beer; A. Pretzfelder, for Manasseh Levy; A. J. Sherrard, Enos Richardson & Co.; O. Sinauer, Oppenheimer Bros. & Veith.

Traveling representatives calling on Syracuse, N. Y., jewelers the past two weeks were: E. Horton, Mandeville, Carrow & Crane; Wm. W. Middlebrook, B. A. Ballou & Co.; L. E. Waterman, Jr., L. E. Waterman Co.; H. S. Hefelee, LaPierre Mfg. Co.; Mr. Rounds, Hancock, Becker & Co.; Walter R. Shute, Day, Clark & Co.; Arthur Lape, Simpson, Hall, Miller & Co.; W. H. Bryant, T. G. Hawkes & Co.; F. C. Gick, Frank M. Whiting & Co.; M. Klipper, Hipp, Didisheim & Bro.; A. M. Connett; Anson D. Manning, D. Wilcox & Co.; E. C. North, Smith & North; Wm. Kinscherf, Jr., for Wm. Kinscherf; W. D. Crittenden, Ithaca Calendar Clock Co.; W. E. Pearse, Howard Sterling Co.; Jas. Panton, Mabie, Todd & Bard; D. C. Osborn, Maple City Glass Co.; W. C. Hughes, for S. A. Weller; Frank L. Wood, Ludwig Nissen & Co.; G. B. Osborn, Wm. Smith & Co.; Frank H. Dana, the H. A. Kirby Co.; Isie Jaskow, Fink, Bodenheimer & Co.; M. Adler; Wm. Guiler, Carter, Hastings & Howe; A. N. Dorchester, Chapin & Hollister Co.; J. A. Holmes, John Russell Cutlery Co.; Fred C. Staudinger, E. A. Lehmann & Co.; M. Gattle, Gattle, Ettinger & Hammel; Harry W. Frohlichstein, Henry Froehlich & Co.; Herman C. Schwartz, Larter, Elcox & Co.; E. F. Skinner, Henry Ginnel & Co.; Fred G. Gruen, D. Gruen & Sons and National Watch Case Co.; J. N. Beckwith, Beckwith & Grant; J. Goldberg; H. E. Sweet, R. F. Simmons & Co.; G. M. Boyce, Louis H. Bronner; W. H. Rupert, J. C. Sawyer; W. H. Warrington, J. T. Scott & Co.; J. Laffey, Gorham Mfg. Co.; B. Rosencrans, for J. C. Hacker. Van Sise & Chapter were also represented.

J. S. Lewis & Co., Ogden, Utah, have put in an elegant new outfit of fixtures.

Harry P. Holmes, East Des Moines, Ia., has removed from 511 to 517 E. Locust St.

Burglars a few days ago secured watches and jewelry worth about \$100 at Sanford & Logan's store, Black Earth, Wis.

D. F. Sullivan, who recently sold out his jewelry business in Rockford, Ill., has been appointed as district agent of the New York Life Insurance Co., in the Rockford district, comprising the counties of Winnebago, Stephenson, Boone, Ogle and McHenry.

# "A bird in the hand, &c., &c."

## THE APPLICATION:

A fair quantity of the right kinds of watches in your stock, WORTH more than double the quantity of the wrong kinds, in the stock of your Competitors.

It goes without saying, that we have the right kinds—

## Elgins, Walthams, Howards.

### C. G. ALFORD & CO.,

195 Broadway,

November 29, 1899.

NEW YORK.

**Boston.**

**TRADE CONDITIONS.**

Jewelers here are making elaborate preparations for a big holiday trade. All indications forecast a remarkable run of business. The call for watches has been particularly pronounced, but gems of all kinds are also in great demand and are expected to show up splendidly at the retail end of the business between now and Christmas. The jobbers will close Thanksgiving Day, but most of them will have to put in some overtime to make up for it. Some of the big houses have been adding two or three hours daily to the working time of their busiest departments. Handlers of ornamental clocks and fine bronzes find the call this season for their goods unusually lively. Sterling silver novelties and table ware are also in special request.

Geo. H. Quaid has been adjudged a bankrupt.

Charles F. Morrill is planning to spend the Winter south.

C. W. Wingate, formerly in business in Newburyport, Mass., has opened a jewelry store on Bromfield St., this city.

Edward R. Holt, plater, was a loser by the fire Thursday night in the building at the corner of Portland and Sudbury Sts.

F. W. Prescott, formerly with Ingraham's optical establishment, has started in business on his own account on Tremont St.

W. S. Tiffany, of the recently incorporated Tiffany Jewelry Co., has resigned the presidency of the corporation to devote his attention to business interests recently acquired in Providence.

Buyers in town during the past week included: M. Hirsch, Holyoke; C. F. Godfrey, Falmouth; L. P. La Bonte, Manchester, N. H.; U. C. Smith, Brockton; Osborn Gillette, Woburn; F. S. Hall, Fitchburg; Mr. Flint, of Flint Bros., St. Johnsbury, Vt.; F. A. Harriman, Waterville, Me.; Charles A. Harriman, Bath, Me.; E. R. Bumps, Thomaston, Me.

Fred C. Babbitt, who was reported in a recent issue of THE CIRCULAR as having opened up a new store at 1022 Washington St., in partnership with C. M. Godsoe, died very suddenly of apoplexy last Wednesday forenoon in his store. He was 55 years of age, and lived in Malden, where he was well known and formerly conducted an optical business.

J. S. Rounds, proprietor of a prominent jewelry instalment business, with branch houses in Bangor, Me., and Worcester, Mass., died last Friday evening at his home in Wakefield, Mass., after a lingering illness from consumption. The business, which has been carried on under the name of J. S. Rounds & Co., will be continued by John J. Rounds, son of the deceased.

W. J. Jenkins, of Brockton, Mass., is financially embarrassed and some of the firms in the Jewelers building, this city, are much interested in the outcome of the affair. They are dissatisfied with the foreclosure of a mortgage held by a relative of Jenkins, it is stated, and also with the manner in which Jenkins loaded up with goods shortly before the news of his difficulties reached them.

Diamond Cutlery Co., with principal office at 164 Market St., Newark, N. J., have incorporated for the manufacture of cutlery. Capital, \$125,000. Incorporators: Dennis V. Bergen, Samuel F. Strong, Willard S. Muchmore, all of Newark.



**Money is in Motion**

but it is moving much faster in some directions than in others.

The swiftest channel—that which is turning goods into money quicker than any other line in the Jewelry business—is that of

*Diamond Jewelry.*

Our line is right in the middle of the current, and Jewelers who bought our goods early in the season are already re-purchasing in very large quantities. \* \* \* \* \*



**STONE SEAL RINGS.**

**GEO. O. STREET & SONS,**

24 JOHN ST., NEW YORK.

... Established 1837 ... TRADE  MARK.

**Stern Bros. & Co.,**

Cutters of ... **DIAMONDS,** Gold Rings and Thimbles, MANUFACTURERS OF  
68 NASSAU STREET, NEW YORK.

RING FACTORY, 33-43 GOLD STREET, NEW YORK. LONDON OFFICE, 29 ELY PLACE.  
DIAMOND-CUTTING WORKS, 142-146 W. 14TH ST., NEW YORK. CHICAGO OFFICE, 149 STATE ST.

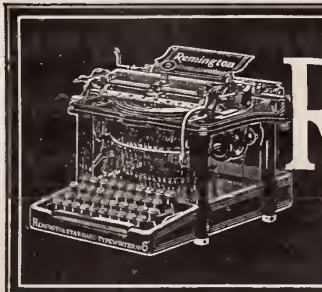

Absolutely Reliable Always  
**Remington**  
Typewriter  
STANDS THE TEST OF CONSTANT SERVICE  
Wyckoff, Seamans & Benedict  
327 Broadway, New York

### Philadelphia.

A. Martin, president of the Pennsylvania Optical Society, has published an interesting book on the cause, effect and correction of eye strain.

Edward L. Warpool, who recently passed a worthless check on jeweler James H. Wright, Wilmington, Del., has been caught and imprisoned.

Thomas D. Pearce, of Pearce & Feraille, was chosen to act as an honorary pall-bearer at the funeral of the venerable politician, James McManes.

A new combination pool and billiard table has been bought by the Philadelphia Jewelers' Club. The pool, billiard and shuffleboard tournament is now in full swing.

D. V. Brown last week finished some important improvements in his wholesale optical establishment at 730 Sansom St. A new counting room has been added to the store.

The contract for about 50 silver trophies to be distributed as prizes at the exhibition of the Keystone Poultry, Pigeon and Pet Stock Association has been awarded to the Bailey, Banks & Biddle Co.

The handsome silver trophies to be awarded as special prizes at the Philadelphia Dog Show and which were presented to the organization by C. B. Newboid, Alexander Van Rensselaer and Mrs. S. Boyd Carrigan have been made by J. E. Caldwell & Co.

The jeweled sword, designed and made by Simons, Bro. & Co., this city, which was recently given to Rear-Admiral Wm. T. Sampson by the State of New Jersey,

has been placed on exhibition in the west arcade of the main building of the National Export Exposition.

Among the local tradesmen who were last week chosen as jurors to serve at the next term of court are: George Henderson, jeweler; August Mensch, optician, 1804 Judson Place; John L. Borsch, optician, 1310 Walnut St., and Charles E. Elliott, silverplater, 616 Poplar St.

The United States Treasury officials were in Philadelphia last week in conference with the Custom House officials. The latter were advised to take every precaution to watch most carefully both passengers and crews of vessels coming to this point to prevent the smuggling of gems into this country. The Treasury officials are fearful that there has been a combination formed in Europe to smuggle pearls and diamonds into America.

Mrs. Samuel Kind, wife of S. S. Kind, the well known wholesale and retail jeweler, died suddenly last Wednesday of heart disease, at her home, 1515 N. 10th St. She had always taken an active interest in charitable work and was widely known and well liked. Two of her sisters, Mrs. S. Schweizer and Mrs. M. Marshall, of Manheim, Germany, had just come to this city to visit Mrs. Kind. Simon and Morris Paelzer, of Paelzer Bros. & Co., are brothers of Mrs. Kind. Her husband and five children, Frank, Morris, Oscar, Philip Kind and Mrs. Joseph Kohn, survive her. She was buried Saturday. Both the 8th St. and Chestnut St. stores were closed in recognition of Mrs. Kind's death.

### Canada Notes.

J. E. Gagnon, jeweler, Quebec, has consented to assign.

The stock of the late G. L. Darling, Simcoe, Ont., is advertised for sale by tender.

D. R. Dingwall, jeweler, has obtained judgment against Thomas Gudjnu, Winnipeg, for \$848.

James M. Whitney, jeweler, Woodstock, Ont., has given a chattel mortgage to J. McCulloch for \$1,546.

J. E. Nelson, jeweler, Ridgetown, Ont., is endeavoring to effect a compromise with his creditors at 33 cents on the dollar on liabilities of \$1,300.

J. B. Pattillo, who recently graduated in the United States as an expert optician, has started in business in Halifax, N. S., and opened handsome optical parlors at 161 Barrington St.

Burglars made a haul of about \$400 worth of silver ware and cutlery from the store of Fletcher & Sheppard, Toronto, some time after 1 o'clock A. M., Nov. 21. The store doors were found unlocked by a policeman and a light was burning.

The many friends of A. J. Whimbey, in Montreal and St. Lambert, presented to him a beautifully illuminated address and Mrs. Whimbey a handsome pair of diamond earrings the other day, the occasion being Mr. Whimbey's leaving the city to take charge of Simpson, Hall, Miller & Co.'s headquarters recently removed to Toronto. Mr. Whimbey was Canadian manager of the firm in Montreal for many years and was several times Mayor of St. Lambert.

## A Brief Argument.

Why not carry our exclusive and fashionable line of Sterling Silver Wares, and those only? **Fashionable**, because of their correct design and perfection of manufacture and finish. **Exclusive**, because they are never found in dry goods stores or made common-place by illustration in department store catalogues.

**Gorham Goods** have those characteristics, with the further advantage of being of unquestioned quality; their productions are never made below the Sterling standard, 925-1000 fine.

**The Prices** are always made as low as are consistent with this quality, combined with good workmanship.



# Gorham Manufacturing Co.,

SILVERSMITHS,

BROADWAY AND 19TH STREET, NEW YORK.

Branches: { 21 to 23 Maiden Lane, New York.  
131 to 137 Wabash Avenue, Chicago.  
118 to 120 Sutter Street, San Francisco.

Works: { Providence, R. I.,  
and  
New York City.

# The Jewelers' Circular

AND  
HOROLOGICAL REVIEW.

PUBLISHED EVERY WEDNESDAY BY  
**THE JEWELERS' CIRCULAR PUB'G CO.,**  
CORBIN BUILDING, 11 JOHN ST., COR. BROADWAY,  
NEW YORK.

TELEPHONE:  
1148 CORTLANDT.

CABLE ADDRESS:  
JEWLAR, NEW YORK.

A JOURNAL DEVOTED TO THE INTERESTS OF JEWELERS,  
WATCHMAKERS, SILVERSMITHS, ELECTRO-PLATE MANU-  
FACTURERS, AND ALL ENGAGED IN KINDRED BRANCHES OF  
INDUSTRY.

Member of the American Trade Press Association.

Our editorial columns will contain our own opinions only, and we shall present in other columns only what we consider of interest or value to our readers. Advertising matter will not be printed as news.

Advertising rates in THE CIRCULAR are lower, considering the number of tradesmen reached by its large circulation, than in any other jewelry journal.

Notices of changes in standing advertisements must be received one week in advance; new matter can be received up to Monday.

## INFORMATION FOR SUBSCRIBERS.

### Terms of Subscription, Postage Prepaid.

	PER ANNUM.
United States and Canada, - - -	\$2.00
Foreign Countries in Postal Union, - - -	4.00
Single Copies, - - -	.10

New Subscribers can commence at any time.

Payments for THE CIRCULAR, when sent by mail, should be made in a Post-Office Money Order, Bank Check or Draft, or an Express Money Order or Registered Letter. All postmasters are required to register letters whenever requested to do so.

Pay money only to authorized collectors having proper credentials.

**Returning Copies.** Returning your paper will not enable us to discontinue it, as we cannot find your name on our books unless your address is given.

**Changing Address.** In changing address always give the old as well as the new one. Your name cannot be found on our books unless this is done.

**Discontinuances** We will continue to send papers until there is a specific order to stop, in connection with which all arrearages must be paid; but such an order can be given at any time, to take effect at or after the expiration of the subscription. All such orders will be promptly acknowledged by mail.

**Liability.** The courts have decided that all subscribers to journals are responsible until arrearages are paid in full and an order to discontinue has been received by the publisher.

### THE JEWELERS' CIRCULAR IN EUROPE.

Among the places in Europe where THE JEWELERS' CIRCULAR is on file are the following:

**LONDON**—First Ave. Hotel, Holborn, E. C.; Holborn Viaduct Hotel, Royal Hotel.

**PARIS**—Hotel de L'Athene, Rue Scribe.

**LEIPZIG**—Handels-Zeitung, für die gesamte Uhren-Industrie.

**BERLIN**—Deutsche Uhrmacher Zeitung, Jäger-Strasse, 73.

**GENEVA**—Journal Suisse D'Horlogerie.

**AMSTERDAM**—Continental Club, Hotel Amstel.

**ANTWERP**—Diamond Club, Rue de Pelican.

Vol. XXXIX. Nov. 29, 1899. No. 18.

Every line of reading matter in THE JEWELERS' CIRCULAR, with the exception of the few brief extracts from exchanges, always properly credited, is written exclusively for this journal. Each issue of THE JEWELERS' CIRCULAR is copyrighted. Permission to quote is extended to other publications provided such quotations are properly credited.

### A Manufacturer of Watches Defined.

IT is a relief to note that the endeavors of a certain class of the too enterprising are not always crowned with success. From time to time the courts in the different States are called upon to aid in preventing the invasion of country districts, as well as the towns, by hawkers, peddlers and auction promoters, without the payment of the just and proper license fees. A salient case in point is that decided last week by Judge Beaver, in the Superior Court of Pennsylvania, whose decision in full is reprinted on another page of this number of THE CIRCULAR. It was alleged that the defendant, E. P. Percival, was a jeweler and watchmaker in Philadelphia, and, during August, 1898, sold several watches at Mount Gretna at private sale and public auction. He was convicted of violating the act of Assembly of April 2, 1830, regulating such sales, without authority. The defendant alleged that he had not violated the act, because he was a manufacturer of the watches, and, therefore, had the right to sell them at auction; also that the act was unconstitutional. From the evidence it appeared that he purchases the movements, dials, springs, hands and cases separately, assembles these parts and puts them into a marketable condition as watches. This proceeding, Judge Beaver points out, does not constitute the defendant a manufacturer, as contemplated by the law. He makes none of the parts and does not expend any labor upon them to fit them for their place. "He purchased no part of any of them as raw material," says the Judge. "Each particular part of the finished watch was in itself a finished product." We entirely indorse Judge Beaver's view of the matter. The defendant is no more a manufacturer of watches than the 20,000 or more dealers of watches throughout the country. Many of these dealers are able to and occasionally are called upon to make a watch from the raw material; but even then some parts, as the balance spring, are bought completed. Few if any of these dealers would designate themselves as watch manufacturers; they are, in addition to being handlers of timepieces, artisans who bring a knowledge of horology to the repairing of timepieces or the occasional duplication of missing parts. If Mr. Percival's contention stood, the virtue of the old law—and it has a great deal of virtue as far as the merchants and the public of small communities are concerned—would be obliterated; for it takes no great skill to put a watch movement into its case, or to adjust the dial and hands. Any peddler or hawker could do this, or readily find someone who could.

### Serious Damage by Fire to the Baltimore Sterling Silver Co.

BALTIMORE, Md., Nov. 25.—The fire that broke out Monday evening on the third floor of the building occupied by the Baltimore Sterling Silver Co., Charles C. Stieff, manager, 318 Cider Alley, caused damage to the building, machinery and patterns of from \$18,000 to \$19,000. The fire started on the third floor, which contains the patterns, moulds and valuable machinery.

### The Pearl Smuggling Case.

**Francois Bock, the Alleged Smuggler, Indicted by the U. S. Grand Jury—The Number of Imitation Pearls 917,000.**

There were interesting new developments last week in the sensational imitation pearl smuggling case, reported in the last issue of THE CIRCULAR. Francois Bock, as already told, who was arrested on the arrival of *La Bretagne*, for attempting to smuggle the imitation pearls in question, was to have been examined before Commissioner Shields on Thursday. When the time came the examination was postponed until the following day, Friday, and then instead of demanding the examination, Bock's attorney, Samuel Greenbaum, waived it on his client's behalf, and Commissioner Shields held the prisoner for the Grand Jury in the same bail, \$5,000.

A more careful examination of the goods shows that there were less imitation pearls in the packages seized than at first had been estimated, the number running upwards of 917,000. The latest appraisal of the goods puts their value at \$1,209.

Bock was indicted by the U. S. Grand Jury yesterday.

### A HENIUS'S TIP LED TO THE ARREST.

PROVIDENCE, R. I., Nov. 24.—Opinions are divided among local manufacturing jewelers as to Francois Bock, who was arrested in New York Monday on the charge of smuggling a large quantity of imitation pearls. Some think that Bock had genuine pearls, but those who are of the opinion that he was bringing over a lot of imitation pearls are largely in the majority.

The authorities found that Bock's prices were lower than those which prevailed in Paris and in Japan, and that Bock was making serious inroads into the business of the principal importers in the United States. They also learned that before Bock sailed abroad the last time he offered to fill orders for 100,000 lots without limit. Arthur Henius, of Bruhl Bros., this city, went to Paris last September and purchased imitation gems for that house, and incidentally he kept tabs on Bock. Upon his return he notified the Customs authorities that Bock would soon arrive with a big stock of imitation pearls. This tip led to the arrest.

### ALLEGED SMUGGLER, ARRESTED IN ST. LOUIS, CLAIMS BOCK IS HIS CONFEDERATE.

ST. LOUIS, Mo., Nov. 22.—The arrest here yesterday of William Bull, charged with smuggling photographic lenses into the United States and some of his confederates in other cities, is regarded by Collector of Customs Smith as the most important made by his department in years. Col. Montgomery, special agent of the Treasury Department, who has been at work on the case for months, says that Bull and his confederates have defrauded the Government out of thousands of dollars.

Bull told Collector Smith that one of his confederates was George Bock, the jeweler of Providence, R. I., who was arrested in New York on the charge of smuggling imitation pearls. Bull claimed that he was in collusion with certain employes of a steamship line.

## Trade-Mark Information.

Note.—The publication of our work, "Trade-Marks of the Jewelry and Kindred Trades," containing over 2,250 marks, all told, the accumulation of various works of reference and the ramifications of our business enable us to trace to their origin nearly all marks that may be found on jewelry, silver ware, art pottery and kindred lines, of both American and foreign make. All questions in regard to trade-marks will be cheerfully answered. We would be pleased to have the trade seek the benefit of our facilities regarding the identity of any marks they cannot trace. We would prefer to receive the article for examination; for if the mark is of foreign origin, the slightest difference between a drawing and the original is of great importance.

No question is too trivial nor too complicated for consideration under this department.

NORTH ADAMS, MASS., Nov. 10, 1899.

Editor of THE JEWELERS' CIRCULAR:

I have just ordered a book of "Trade-Marks" of your agent, and I showed him this piece of a pair of scissors. We could not make out what the trade-mark was, and he advised me to send it to you. So I do so. Can you inform me who the maker was?

Yours truly,

L. M. BARNES.

ANSWER:—The stamp is an indistinct representation of the mark of the LaPierre

TRADE MARK  
L

Mfg. Co., 33 Union Square, New York. See page 44 of "Trade-Marks of the Jewelry and Kindred Trades," published by The Jewelers' Circular Pub. Co.

PROVIDENCE, R. I., Nov. 18, 1899.

Editor of THE JEWELERS' CIRCULAR:

We enclose herewith sketch of a trade-mark on a silver spoon. We are unable to place this. Will



you kindly let us know the name of the maker? and oblige,

Yours respectfully,

TILDEN-THURBER Co.

ANSWER:—The mark belongs to Watson & Newell Co., Attleboro, Mass. See page 50, "Trade-Marks of the Jewelry and Kindred Trades," published by The Jewelers' Circular Pub. Co.

SALTSBURG, Pa., Nov. 20, 1899.

Editor of THE JEWELERS' CIRCULAR:

I enclose stamp for which will you please inform me what firm makes the collar button having

ACME

stamped on post, and oblige?

Yours very truly,

H. J. TAYLOR.

ANSWER:—S. & B. Lederer Co., 11 John St., New York, make the "Acme" lever collar button.

Baltimore.

Louis De Baer, formerly with Samuel Kirk & Son Co., has accepted a position with Pioneer Jewelry Co.

The store of S. I. Rodberg & Son was entered by a colored man on the 24th, who stole two diamond rings valued at \$90 each.

## Last Week's New York Arrivals.

THE CIRCULAR has perfected arrangements for obtaining the names and hotel addresses of all the latest buyers visiting New York, and each day posts in its office, 11 John St., cor. Broadway, a bulletin which every member of the trade is cordially invited to copy.

Albany, N. Y., F. W. Hoffman, Imperial.  
A. J. Becker (J. G. Myers), 487 Bway.  
Baltimore, Md., J. S. MacDonald, Imperial.  
Boston, Mass., S. T. Pierce (R. H. White & Co.), 480 Broome St.  
A. T. Otis (Pitts, Kimball & Co.), Broadway Central.  
A. W. Paul (A. Paul & Co.), Marlborough.  
Cleveland, O., P. J. Dolt (Williams & Rodgers Co.), 335 Broadway.  
Denver, Col., M. I. Ward, Herald Square.  
Detroit, Mich., C. F. Hammond, Holland.  
Elmira, N. Y., A. Samuels, Belvedere.  
Fall River, Mass., R. J. Viau, B'way Cent.  
Lancaster, Pa., A. Rhoads, Imperial.  
Louisville, Ky., N. L. Rodgers (Rodgers & Pottinger O. & J. Co.), Gd. Union.  
Milton, Pa., A. F. Hitchler, Metropolitan.  
Philadelphia, Pa., F. Levy, Imperial.  
Pittsburgh, Pa., E. R. Hill, Gd. Union.  
Richmond, Va., C. Galeski, Everett.  
Syracuse, N. Y., S. M. Shimberg, Astor.  
Miss A. M. Smith (E. W. Edwards & Sons), Albert.  
Spartansburg, S. C., P. Luckey, Astor.  
Susquehanna, Pa., A. M. Bronson, Mort'n.  
Toronto, Can., J. G. Kent, Astor.  
Wyalusing, Pa., H. J. Hallock, Astor.  
York, Pa., I. I. Cohen (Cohen & Pirost), St. Cloud.

## Syracuse.

William A. Corbett, the man who presented forged orders to several local jewelers a few months ago, pleaded guilty in County Court Nov. 14 to forgery in the second degree and said that he preferred to take two days before the passage of sentence. He pleaded not guilty when arraigned three weeks ago.

The death of Mrs. Louis Leiter, wife of Louis Leiter, of Leiter Bros., occurred early last Wednesday morning at her home in Warren St. Mrs. Leiter had been ill but a few days, and her sudden demise came as a great shock to her family and the many friends who knew and valued her many lovely qualities. Mrs. Leiter had been a resident of Syracuse all her life, and is survived by her husband and three sons.

John Collins, 29 years old, of Lancaster, Pa.; William O'Brien, 32, of this city; George Deitch, also of this city, were before Justice Thompson last Tuesday on the charge of burglary and larceny. It was alleged that they entered Charles H. Miller's jewelry store and stole a quantity of silver ware. They pleaded not guilty, although Una Bill identified Collins as the man who on the day succeeding the burglary tried to sell her some spoons and pearl handled nut picks. All were new goods. They were held.

## ON MEMORANDUM

You'll have all kinds of stockings to cater to in the next few weeks, and nowhere will you get such an assortment of Diamonds and Diamond Jewelry as we can send you; but they won't last long in view of the rising market. Don't forget that our goods were bought months ago, and, notwithstanding the rises, will be sold at nearly the old prices, while they last. Anything you want—loose or mounted—"On Memo."

V. WARING, N.Y.

# CROSS & BEGUELIN

Importers and Cutters of Diamonds and Precious Stones

43 Rue de Meslay, PARIS

17 Maiden Lane, NEW YORK



**New York Notes-**

The Johnston Optical Co. have entered a judgment for \$139.25 against Richard H. Poillon.

Camerden & Forster have entered a judgment for \$99.51 against Samuel H. Hopkins.

The Max Nathan Co., of New York, have been incorporated to deal in diamonds, jewelry and pearls, with a capital of \$5,000. Max Nathan, E. H. Nathan and Carl J. Nanz, New York, are the directors.

In the Yorkville Police Court last week Martin Blank, who gave his occupation as a jeweler, was held in \$3,000 bail for examination on a charge of burglary. Mrs. Catherine Heintz, of 389 Park Ave., found him ransacking her rooms, and was almost choked by him. The man finally threw her on the floor and ran out of the room, but was captured.

The American Watch & Diamond Co., 19 Maiden Lane, applied last week to the Supreme Court for the voluntary dissolution of the corporation, and Judge Truax Wednesday appointed John Hone referee in the matter. The company have no liabilities and no assets, as they have sold all their property and distributed the proceeds among the stockholders. Directors Hugo Baer, William I. Rosenfeld and Bertha H. Schwartz made the application.

Saul Prager, a wholesale jeweler doing business in the Anderson building, 12-16 John St., filed a voluntary petition in bankruptcy in the United States District Court, Wednesday. The schedules filed with the petition show his liabilities to be \$3,601.51, of which \$3,309.51 is on unsecured claims and \$292 on notes and bills for which other parties are jointly liable. There are no creditors holding securities, and all the liabilities were contracted between 1894 and 1897. He has no assets. Among the principal creditors are: Max Kolliner, Minneapolis, Minn., \$1,500; J. A. Browne, \$627; H. K. Sheldon, \$312; B. Berman, \$245; James and Rosalie Schawel, \$158; E. Limbach, \$250; M. Kollender, \$115; E. L. Anrich, \$100, and Lewisohn & Co., \$192.

Adolph Spieler, who gave his occupation as a jeweler, of 127 Broome St., was arrested Thursday on an order issued by Judge Bookstaver, of the Supreme Court, in a civil suit brought by Bessie Birn Spieler. The plaintiff, who is 18 years of age, sues for \$25,000 damages on the claim that Spieler induced her to marry him although he had another wife living at the time. Spieler's first wife, to whom,

it is stated, he was married six years ago, secured a separation from him some time ago, and he was ordered to pay alimony. An order was issued the same day by Judge Bookstaver, on the application of his first wife, to show cause why he should not be committed for contempt of court in his failure to pay the alimony now past due. He was held in \$2,500 bail in the first named action for damages.

An old failure was recalled Thursday when Isaac Steinau, of 147 E. 61st St., filed a petition in bankruptcy, with liabilities of \$41,160 and no assets. He was formerly of Steinau Bros. & Co., wholesale jewelers, 441 Broadway, who made an assignment in August, 1882, and \$32,550 of the liabilities are on that firm's account. The balance of the liabilities, \$8,610, are individual debts contracted in the past two years in the restaurant business. Among the creditors of Steinau Bros. & Co. for more than \$500 are: Watson, Newell & Co., \$2,506; T. I. Smith & Co., \$1,797; G. A. Babbitt and others, \$928; Chas. Bushee and others, \$1,021; Horton, Angell & Co., \$1,069; P. & A. Linton, \$877; A. Liebermuth, \$3,257; S. & B. Lederer, \$837; Bates & Bacon, \$1,824; M. Fitzgerald & Co., \$592; Robinson & Co., \$865; Cummings & Wexel, \$1,320; W. H. Wilmarth, \$1,439, and several others not in the jewelry trade.

A well known crook, whose picture is in the rogues' gallery, was arrested in Maiden Lane, Thursday, by Detectives Nugent and Madden. The man's name is Frank Bernard and he is also well known

by several aliases, among which are Lewis, Roberts and Baron Rudolph. When he entered the "Lane" he was at once spotted by the detectives, who followed him to 19 Maiden Lane and waited at the entrance of that building.



**Jewelry  
Store  
Style**

is embodied to a remarkable extent in the Holiday styles of

**Waterman's  
Ideal  
Fountain  
Pen.**

They are the most beautiful articles of unlimited usefulness that your stock contains. Have a full stock; there's advantage in it.

**L. E. Waterman Co.,  
155-157 Broadway, New York.**

**Largest Manufacturers of  
Fountain Pens in the World.**

While we cannot take any more orders to be made up before January 1st, we have a large and varied stock of CUT GLASS in New York for prompt shipment.

**C. Dorflinger & Sons,  
36 MURRAY STREET, NEW YORK.**

1851.

1899.

**THE CHATHAM NATIONAL BANK, NEW YORK.**

**CAPITAL STOCK, - - - - \$450,000  
UNDIVIDED PROFITS, - - - - 974,518**

**GEO. M. HARD, President.**

**H. P. DOREMUS, Cashier.**

**W. H. STRAWN, Ass't Cashier.**

## Beauty, Quality, Workmanship,

combined, are what make the Bell Gold-Filled Watch Cases the best filled cases made. You may know of many advantages of handling these cases, but you probably don't know them all. Write and learn of the many ways in which we aid you in selling these cases.



You can have any special design, emblem or monogram engraved on a case when you

**Buy of the Maker.**

**THE BELL WATCH  
CASE CO.,  
CINCINNATI, OHIO.**

### New York Notes.

(Continued.)

Here Bernard went to the office of Averbeck & Averbeck, wholesale jewelers, and represented himself to be a traveling salesman. While inspecting a number of pieces of jewelry, Bernard attempted to palm a few and was detected by a salesman, who ran down for an officer. The detectives who were waiting at the door came up and arrested Bernard, and a search disclosed that he had stolen three scarf pins and two brooches, worth about \$52. The thief was taken to the Centre St. Court where he waived examination and pleaded guilty. Magistrate Poole held him in \$1,000 bail for the Grand Jury. Bernard is known as an expert "pennyweight" thief, and was arrested in July, 1895, by the same detectives. Nugent and Madden, for stealing umbrella handles from Bierman, Heidelberg & Co., for which crime he served one year in prison. He is 5 feet 10 inches in height, of medium build, wears a dark mustache and dresses well.

Philip Krukin, formerly of Manhattan borough, is now located at 343 Fulton St., Brooklyn.

J. W. Lederer, of S. & B. Lederer Co., Providence, R. I., was in New York last week for a few days.

Daniel Birdsall & Co. last week sold for Mrs. Emily Thorburn the vacant lot, 25.8x 120.10, at 15 John St., adjoining the Corbin building. The name of the purchaser or the price paid could not be learned.

Bessie M. Gattle, the 15 year old daughter of Emanuel M. Gattle, died Saturday. Funeral services were held yesterday morning at Temple Israel, 125th St. and Fifth Ave.

A meeting of the creditors of Jacob W. and W. B. Smith, doing business as B. & W. B. Smith, manufacturers of architectural woodwork, was held Friday before Referee in Bankruptcy Geo. C. Holt, at 34 Pine St. About 50 claims were filed and W. S. Edgar was elected trustee. The liabilities are \$82,925 and assets \$70,431.

Mrs. Carrie Kolenberger, Wednesday morning, had summoned to the Adams St. Police Court, Brooklyn, a man who had sold to her a ring for \$14 at the Montana Diamond Co.'s store, Fulton St., in that borough. She claimed that she found the ring was worth only \$1, and that the accused refused to give her back her mon-

ey. The man was ordered by Magistrate Bremer to take back the ring and return the purchase price, and upon doing so was discharged.

M. Gittleman, a traveling jewelry salesman, whose name was connected with the recent discharge of a number of conductors on the Long Island Railroad, last week sent the following statement to the *Brooklyn Times*:

"To the public of Long Island: I desire to say to my many friends and patrons with whom I have had business and social relations for many years that the rumors now current that through my disclosures many conductors employed upon the Long Island Railroad have been discharged, are wholly without foundation in fact. I have never asked, nor received, any favor in the way of free passage from any conductor, nor have I ever so stated. I ask my friends to withhold judgment until they have heard both sides of this matter.

"M. GITTLEMAN."

As foretold in a recent issue of THE CIRCULAR Geo. H. Howland, of Kleinschmidt, Howland & Co., diamond importers, 189 Broadway, and Miss Ida C. Milligan, of Brooklyn, were married Wednesday last at St. Peter's Episcopal Church, State St. near Bond St., Brooklyn. Rev. Lindsay Parker, assisted by the Rev. Ferris Tripp, performed the ceremony. The bride was given away by her cousin, Louis Kimball, with Cross & Beguelin, and the best man was Daniel Scofield, of Scofield, Melcher & Scofield. Chas. Donnell and Jas. Williamson were the ushers. Mr. and Mrs. Howland are now in the south on their wedding trip.

A dispatch from Sag Harbor states that 150 piece work engravers of the Fahys Watch Case Co. have demanded a change to week work employment. The matter is under consideration by the management, who are willing to accede to the request if an amicable settlement of wages can be arranged. The cause of the demand is that a better class of work is required to be turned out now, and the fact that all the New York engravers employed here are on week work and that most of the principal shops in the country, including the branch of the Fahys company in New York, are on week wages. Only a short while ago a demand was made by the association for 15 per cent increase on all piece work. It was granted by the company.

Creditors of Saul Prager, who filed a petition in bankruptcy Wednesday, are notified that the first creditors' meeting will

## Mossberg & Granville Mfg. Co.,

PROVIDENCE, R. I.

MANUFACTURERS OF

### JEWELERS' AND SILVERSMITHS' MACHINERY.

**Power Presses, Wire Drawing Machinery,  
Rolling Mills, fitted with Roller Bearings.**

If in the market for the above machinery, write us, sending samples with output required and let us send you photographs of our latest productions.

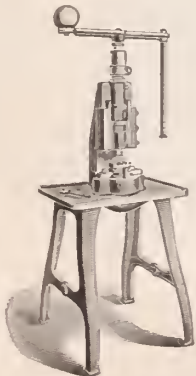

No. 1A, Screw Press. N. Y. Office, 26 LIBERTY STREET.

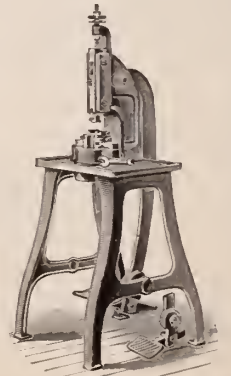

Exhibition at the Philadelphia Bourse.

No. 1A, Foot Press.

**New York Notes.***(Continued.)*

be held on Dec. 15, at the office of Theodore Aub. referee in bankruptcy, 149 Broadway.

Jos. B. and M. L. Bowden, of J. B. Bowden & Co., ring manufacturers, have the sympathy of their fellow members in the trade in the loss of their mother, Charlotte F. Bowden, which occurred Nov. 21. Mrs. Bowden was the widow of Joseph Bowden, the founder of the business continued by his sons, and was 75 years old. The funeral services were held Friday at her late home in Flushing, L. I., and the remains were interred in Cypress Hills Cemetery.

The motions told of in THE CIRCULAR last week, made by the L. E. Waterman Co. to amend their complaints in the action against Vassar College and Jno. P. Ambler, have been denied by Judge Lacombe, of the United States Circuit Court. The actions were for alleged infringements on patents granted on the feed device of fountain pens, and the defendants had pleaded that one of these patents had already expired before the suits in question had been commenced. The motions were to strike out the reference to this patent in the complaints, but the Judge did not deem this necessary.

John Treherne and George Taylor, who, as told in THE CIRCULAR last week, were arrested by the Customs officials on the charge of smuggling costly lenses and other photographic apparatus, were before United States Commissioner Alexander Friday afternoon for examination. Taylor, as already told, is a steward on board the *Etruria*, and Treherne, a friend of his, claimed that he was an innocent victim, and had unwittingly taken a package which Taylor had given him to deliver in the city. The prisoners both waived examination, and Commissioner Alexander held them for the Grand Jury in \$2,500 bail.

**The Demand for Rich Goods.**

FOR years Alfred H. Smith & Co., 182 Broadway, New York, have been prominent as importers of the rarest gems coming to this country, but this Autumn they have excelled all previous records. Their offerings have included very rare rubies of high value, pairs of Oriental pearls as large as 100 grains, superb single pearls of high quality, important strings and ropes of pearls, etc.; also rare emeralds, sapphires and diamonds. Some of these goods have been sold, but at present their stock contains some of the rarest and most expensive pearls to be found in the American market, as well as equally fine diamonds and exceptional rubies up to 7½k. One of the finest diamonds in the country and now in their stock is a superb "river" stone, absolutely perfect, which weighs over 13 karats. Among other notable pieces which forcibly strike the attention of the visitor to this firm's offices are a number of large pieces mounted with pearls, emeralds and diamonds, such as stomachers and necklaces.

**Providence.**

Louis Kranz, die sinker and designer, has removed to commodious quarters, at 150 Orange St. Mr. Kranz's old place of business was on Weybosset St., but increasing patronage forced him to take more roomy quarters.

Jacob L. Meyers, a veteran journeyman jeweler, died at his home last Monday, from heart failure, superinduced by indigestion. At the age of 17 years Mr. Meyers came to this city, learning the jeweler's trade from the senior J. B. Maintien. Later he accepted a position with Robert Barton, leaving there in 1863 to fill a position with Mathewson & Allen, remaining until the dissolution of the firm. From that time he held a good position with J. B. Mathewson & Co., and then with their successors, the C. H. Cooke Co.

**The Attleboros.**

A carload of new machinery for the Frank Mossberg Co. arrived last week in Attleboro.

G. K. Webster & Co. added two hours to their working day last week. This firm are among the busiest in the Attleboros.

Woodbury Melcher purchased a large piece of land in North Attleboro, last week, and has given contracts for the erection of a fine dwelling house.

William J. Ritchie, for years with the Horton, Angell Co., now one of the trusted employes of J. M. Fisher & Co., has mysteriously disappeared. He left home with \$145 in his pocket. He was a skilled workman and an exemplary man, and the matter creates much interest.

Sidney O. Bigney, of S. O. Bigney & Co., was approached lately to allow his name to be used for the presidency of the Bristol County Agricultural Association. He declined, owing to the demands made upon him by his big business and the construction of his factory.

It is reported that Eugene and Clarence Skinner, charged with breaking and entering at several Attleboro shops, went before the Superior Court last week and entered a plea of guilty. It is expected that they will receive lenient treatment.

A unique gathering, but one filled with patriotism, was the 13th annual reunion and banquet of the Association of ex-Prisoners of War, in Attleboro, last week. Major Everett S. Horton, of the Horton, Angell Co.; Emmons D. Guild, of the W. H. Wilmarth Co., and Edward C. Martin, another jeweler, have engineered these gatherings since their inception with increasing measure of success.

A fortunate discovery of an incipient blaze saved the Bates building, Union St., occupied by the D. F. Briggs Co., Charles M. Robbins, Dolan & Co., Simms & Co. and other firms. Some papers picked up in cleaning around the shop had been thrust into one of the forges. Blazing fragments blew back onto the floor, and being unseen for several hours, set fire to the woodwork in front of the forge. The first man in the morning discovered the flames, which had gotten a good headway, and he quickly extinguished them.

On the date of this issue occurs in Attleboro the largest and most fashionable wedding of the year. Miss Mary Elmer

**"THE AMERICAN BEAUTY"****Sterling and  
Essex Gold Filled.****UNEQUALED.**

PRICE, \$2.00. FOR SALE BY ALL JOBBERS.

**Hayden Mfg. Co.,****21-23 MAIDEN LANE,  
NEW YORK.**

Bushee, only daughter of Mr. and Mrs. Albert A. Bushee, is to be married to James Hope Arthur of this town. Mr. Arthur is employed in the jewelry house of A. Bushee & Co., at the head of which is Albert A. Bushee. The wedding takes place at 7.30 o'clock, in the Second Congregational Church, beautifully decorated for the event. Rev. Elwin L. House, of Boston, officiates, and the bridal party numbers 21.

An era of moving has struck the tenants of the Robinson building, No. 3, on Union St., Attleboro. McRae & Keeler have left the building and gone into the new Bates factory, on Mill St. The two floors they vacated were instantly filled. The S. M. Einstein Co., mail order jobbing house, moved into one floor, and the other is shared by the new firm of Sykes & Strandberg and by Richards, Hill & Co. The basement vacated thus by Richards, Hill & Co. has been taken by Cyprien Dion.

### CONSULT

## "The New York Jeweler"

Before Buying Jewelry or Kindred Lines.

For 26 years the acknowledged authority for all that is new, artistic and beautiful in the Jewelry World.



724 Pages. Size, 9x13.

This profusely illustrated catalogue enables the dealer to make a better selection than the majority of travelers' stocks affords.

## S. F. MYERS CO.,

MANUFACTURING and WHOLESALE JEWELERS

Myers Building, 48-50 Maiden Lane, New York.

Mention Dept. G 12 when sending for catalogue.



## DEITSCH BROS.,

14 East 17th St.,  
New York.

LEATHER. SHELL,  
EBONY, IVORY.

## THE LEDOS MFG. CO.,

MANUFACTURERS OF

## Watch Case Materials,

Crowns, Pendants, Bows, Solders,  
Springs, Findings, Etc.,

34-36 PEARL ST., NEWARK, N. J.

### Collector Bidwell Releases the Peabody Diamonds

Collector Bidwell, after the hearing on the case of the diamonds belonging to Adolph Peabody, which have been detained at the Custom House, has decided to return to Mr. Peabody absolutely and without payment of duty all those diamonds which he had positively identified as having been cut in this country. Deputy Collectors Couch and Phelps, assisted by Jewelry Examiner Geo. W. Mindil, Friday afternoon went over the goods and separated those identified as American cut from the others. The remainder of the diamonds the Collector, by order of the Treasury Department, will release to Mr. Peabody upon the payment of the full duty. The lot of stones, it was shown, had been taken from this country by Mr. Peabody to Europe and reimported without payment of duty. The customs authorities believed that there was no intent to smuggle as Peabody was under the impression they were not dutiable, and that only a technical violation of the customs laws had been committed.

The stones released to Mr. Peabody are in number less than half, but in value more than half of the entire amount involved. The goods held for duty will be the pearls, precious stones and melée, while the goods released absolutely will be the diamonds of more than half karat.

### Daniel Earl Reports the Loss of Over \$7,000 Worth of Precious Stones.

CHICAGO, Ill., Nov. 27.—Daniel Earl, a diamond importer, is reported to have lost a leather pouch containing \$7,363 worth of diamonds, rubies, sapphires and other precious stones while carrying it from his office to the safety deposit vaults Saturday night. He placed the pouch in his outside coat pocket and missed it when in the street.

The business of E. H. Hynson, Smyrna, Del., who recently died, is closed.

## JULES J. LINTZ,

## Watch and Chronometer Maker

FOR THE TRADE.

Two Diplomas and First Prizes for Scientific Workmanship.

108 Fulton Street, New York.

Downing Bldg., Room 1019.

Repairing of Fine and Complicated Watches  
Pocket and Marine Chronometers.

All kinds of New Pieces made to order and adjusted.

## TO BLOW EFFECTIVELY IS AN ART

which we never practice personally; but we have invented a machine which does it for us, called the

"Reichhelm Pressure Blower."

This, with Gas Furnaces and Jewelers' Tools generally, is the stock in trade of

E. P. REICHHHELM & CO.,  
23 JOHN STREET, NEW YORK CITY.

### News Gleanings.

E. B. Culpeper has removed from Buchanan, Tenn., to Hazel, Ky.

B. F. Giddens, Knoxville, Tenn., recently sold out to G. F. Hauser.

H. T. Harris has removed from Denning, N. M., to Silver City, N. M.

Frank Pequegnat, St. Louis, Mich., has been succeeded by A. W. Pequegnat.

L. W. E. Goldiuss, of Oconomowoc, Wis., has opened a jewelry store in Horicon, Wis.

The loss to George E. Sherwood, in the recent fire in Seneca, N. Y., has been adjusted at \$150.

H. J. Knapp, of Traverse City, Mich., has bought out A. Large's jewelry store, Bellaire, Mich.

The Armstrong Jewelry Co. building, Brownwood, Tex., has been sold to E. B. McGhee for \$3,000.

F. L. Clawson, formerly of Woodson & Clawson, Clarence, Mo., will open a new jewelry store in a few days.

The business of H. S. Pond, Melrose, Mon., who recently died, is being continued by Miss Ethelia Pond.

J. C. Johnston, Mt. Sterling, Ill., has removed the remainder of his stock to Clayton, Ill., to sell at auction.

An attempt was made to burglarize the jewelry store of G. E. Smith & Sons, Parkersburg, W. Va., on the night of Nov. 22.

The jewelry business of T. K. Brunner & Son, Circleville, O., will be continued by Fred B. Brunner, his father having transferred the business to him in 1898.

A man entered Spencer's jewelry store, Kingston, N. Y., shortly after 6 o'clock last Wednesday night and took away two watches which were shown to him and which he said he wanted to buy.

The jewelry store of August Reher, Pana, Ill., was broken into on the night of Nov. 20, and robbed of over \$200 worth of silver ware, jewelry, etc. The robbers are thought to be residents of that city.

H. M. Dayton's jewelry store, Colo, Ia., was broken into last Wednesday night and the following goods taken: One York silver plated cornet, one Boley lathe, one Prentiss vise and most all of his jewelry tools. Ten dollars reward is offered.

The jewelry store of Leon de la Reussille, Red Bank, N. J., was entered by a burglar Sunday morning last and about \$60 worth of sterling and plated silver ware was stolen. Entrance was effected through a rear window. The robbery was committed between the hours of 4 and 6 o'clock.

F. C. O'Harra, Edgmont Ave. and Welsh St., Chester, Pa., has sold his jewelry store to William G. Atherholt. The store was formerly owned by Atherholt & Co., but when Mr. Atherholt went to Pittsburgh he sold out his interest in the firm to Mr. O'Harra. Mr. Atherholt bought the entire stock and the establishment will be run under his name.

Sneak thieves made a considerable haul on the evening of Nov. 20, from the shop of A. L. Hause, manufacturing jeweler, on the second floor of the building, northeast corner of Adams and Superior Sts., Toledo, O. While the operatives were at supper a valise containing 25 watches, a quantity of jewelry and gold cases and parts of watches was taken from the place.

## Special Notices.

### Situations Wanted.

**WATCHMAKER**—Expert on fine work would like to exchange his position; satisfactory reasons given. Address "Escapement," care Jewelers' Circular.

**YOUNG MAN** wants position to learn jewelry business; three months' experience in Waltham Horological School; references. Address F. R. Seymour, Lunenburg, Mass.

**OPTICIAN**—Wanted, a situation by a steady, all-around workman; good gold solderer, edge grinder and general repairer; references. Address J. H., care Jewelers' Circular.

**PRACTICAL DESIGNER**, with 15 years' experience in all branches of sterling silver ware, desires position; All references furnished. Address "Sterling," care Jewelers' Circular.

**SUPERINTENDENT AND DESIGNER** with large experience in all branches of sterling silver ware desires position; best of references. Address "Designer," care Jewelers' Circular.

**STRICTLY HIGH GRADE** watchmaker, 18 years' experience on fine watches; speaks French and English; \$25 per week; none but strictly first-class house need apply. Address 35, M., care Jewelers' Circular.

**SITUATION WANTED** by first-class watchmaker, jewelry repairer and engraver; 15 years' experience; competent to take charge of all work; permanent position if any. Address "Jeweler," 190 Oak St., Lewiston, Me.

**OPTICIAN**, watchmaker and engraver wants a steady position with a good firm; understands the business thoroughly; young man, single, sober and steady; have tools and trial case; state salary in first letter; All references. Address "Optician," care Jewelers' Circular.

**REFRACTING OPTICIAN** of 25 years' practical experience, skilled in all modern methods of examination and having a thorough knowledge of the jewelry business, is open for engagement with a first-class jewelry house desirous of opening an optical department; unexceptional reference. Address A., care Jewelers' Circular.

### Help Wanted.

**WANTED**—Watchmaker; young, single man preferred; permanent job. F. E. Hull, Saranac Lake, N. Y.

**WANTED**—Salesman for southern and southwestern trade. Zimmern, Rees & Co., 9-13 Maiden Lane, New York.

**WANTED**—An experienced designer on sterling silver hollow ware and novelties. Address "Silversmith," care Jewelers' Circular.

**WANTED**—First-class watchmaker and optician; \$13 and share in optical department; large city in New York State. Address, with references, M., care Jewelers' Circular.

**WANTED**—Two first-class manufacturing jewelers and stone setters; one first-class engraver and jeweler; references required. Geo. Wettstein, manufacturing jeweler, Cedar Rapids, Iowa.

**WANTED**—An experienced traveler for the Eastern, Middle and Southern States to sell a general line of watches, diamonds and jewelry. R., L. & M. Friedlander, 30 Maiden Lane, New York.

**WANTED**—A first-class optician, watchmaker and engraver; none other need apply; state wages desired in first letter; a permanent position guaranteed to right man. Address B., care Jewelers' Circular.

**WANTED**—Young man, good on clock and jewelry repairing and who can do plain watch work; must have own tools and lathe; good habits, reliable, willing and energetic; state wages desired and ability in detail in first letter. Address J. C. D., care Jewelers' Circular.

**AFTER JAN. 1**—A first-class manufacturing jeweler and stone setter who can make all kinds of diamond mountings, cluster work, and understands enameling and the use of dynamo for gilding and plating, as foreman in a newly equipped shop with six to eight men; highest salary and permanent position to right man; best of references required. Address G. O., care Jewelers' Circular.

### Business Opportunities.

**FOR 30 DAYS** I offer my jewelry business, or fixtures only, at a very low price; I have been established 35 years. Wm. F. Wallace, Westerly, R. I.

**FOR SALE**—A good jewelry and repair business; New York town of 3,000; established 1887; repairs \$60 to \$70 per month; invoice about \$600. Address "S. 78," care Jewelers' Circular.

## INDEX TO ADVERTISEMENTS.

Aikin, Lambert & Co.....	51	Kahn, L. & M., & Co.....	52
Aikin, Lambert Jewelry Co.....	51	Knowles, Dr.....	48
Alford, C. G., & Co.....	24	Knowles, J. B. & S. M., Co.....	9
American Watch Case Co.....	51	Kohn & Co.....	25
American Waltham Watch Co.....	15	Kohn, Alois, & Co.....	41
Arnstein Bros. & Co.....	52	Lady Racine.....	50
Austin, John, & Son.....	52	Le Boutillier & Co.....	52
Averbeck & Averbeck.....	34	Lederer, S. & B., Co.....	52
Avery & Brown.....	16	Ledos Mfg. Co.....	32
Ball, Wm. H., & Co.....	50	Levy, L. W., & Co.....	47
Bassett Jewelry Co.....	48	Lind, Thomas W.....	4
Bell Watch Case Co.....	30	Lintz, Jules J.....	32
Billings, Chester, & Son.....	19	Malliet, C. G., & Co.....	18
Bowden, J. B., & Co.....	18	Mathews & Prior.....	44
Bradley Polytechnic Institute.....	52	Mathey Bros., Mathez & Co.....	12
Bradley & Hubbard Co.....	48	Mausier Mfg. Co.....	4
Bryant, M. B., & Co.....	50	Mercantile National Bank.....	37
Chatham National Bank.....	29	Mossberg & Granville Mfg. Co.....	30
Clark & Coombs.....	51	Mount & Woodhull.....	18
Conley & Straight.....	52	Myers, S. F., Co.....	32
Cook, Edward N.....	51	New England Watch Co.....	13
Cross & Beguelin.....	28	Omega Watches.....	16
Crossman, Charles S., & Co.....	19	Oppenheimer Bros. & Veith.....	19
Crouch & Fitzgerald.....	48	Pairpoint Mfg. Co.....	48
Crown and Lion Watch Cases.....	19	Potter, Wm. K.....	21
Day, Clark & Co.....	52	Powell, S. C.....	23
Deitsch Bros.....	32	Providence Stock Co.....	52
Didisheim, Hipp., & Bro.....	14	Reichhelm, E. P., & Co.....	32
Dorflinger, C., & Sons.....	29	Reisner, L. C., & Co.....	3
Dubois Watch Case Co.....	47	Remington Typewriters.....	25
Dueber-Hampden Co.....	11	Rich, H. M., & Co.....	48
Eaton & Glover.....	48	Robert, E. E.....	14
Eisenmann Bros.....	20	Roy Watch Case Co.....	36
Eliassof Bros. & Co.....	44	Rumpp, C. F., & Sons.....	47
Esser & Barry.....	51	Saunders, John F.....	19
Fahys, Jos., & Co.....	41	Schulz & Rudolph.....	18
Fairchild & Johnson Co.....	52	Selwyn Importing and Trading Co.....	47
Field & Beattie.....	48	Sherwood, John W., & Co.....	10
Foster, Theodore W., & Bro. Co.....	2	Simmons, R. F., & Co.....	48
Frankel's Sons, Jos.....	21	Simmons & Paye.....	48
Freund, Henry, & Bro.....	23	Simons, Bro. & Co.....	21
Friedlander, R., L. & M.....	52	Smith, Alfred H., & Co.....	20
Fuchs, Ferd., & Bros.....	51	Solomon Bros. & Gross.....	35
Goodfriend Bros.....	19	Stern Bros. & Co.....	25
Goodnow & Jenks.....	2	Sternau, S., & Co.....	23
Gorham Mfg. Co.....	26	Strasburger, Byron L., & Co.....	20
Gregory, E. J.....	46	Street, Geo. O., & Sons.....	25
Harris & Harrington.....	52	Sussfeld, Lorsch & Co.....	46
Hayden Mfg. Co.....	31	Towle Mfg. Co.....	40
Hedges, Wm. S., & Co.....	18	Treibs Bros.....	21
Heimberger & Lind.....	43	Trenton Watch Co.....	12
Howard Sterling Co.....	7	Wallace, R., & Sons Mfg. Co.....	6
Iraba, Louis W.....	48	Waterman, L. E., Co.....	29
Hughes, James D.....	16	Westphal, W. C. A.....	51
Imperial Mfg. Co.....	40	Wheeler, Hayden W., & Co.....	22
International Silver Co.....	5	Whiting, F. M., & Co.....	8
Jacot & Son.....	51	Wood, Chas. F., & Co.....	52
Juergensen, Jules.....	18	Wood & Hughes.....	48
		Woods & Chattelier.....	17

**FOR SALE**—Well established small jewelry and optical goods store on leading business street in Brooklyn; exceptionally good opportunity for fine watchmaker with small capital. Address R. A., care Jewelers' Circular.

**JEWELRY STOCKS BOUGHT**—Retailers wishing to dispose of surplus or entire stock of diamonds, watches and jewelry can find quick, cash, strictly confidential buyer by addressing S. Marx, 22 Lispenard St., New York City.

### For Sale.

**FOR SALE**—3 8-ft. show cases, \$25 each; 1 5-ft. 6 in. show case, \$18; these cases are 16 in. high, 24 in. wide, black enamel wood, all plate glass, including mirrors; good condition; 1 oak wall case, 25 ft. long, 6 ft. high, 20 in. deep, 30x50 plate glass mirrors, all lined with black felt; double thick glass in lift sash; medium condition; \$50. The Ruddy Jewelry and Optical Co., 145 State St., New London, Conn.

### To Let.

**FRONT OFFICE**, 18x72 (occupied by the E. Howard Watch & Clock Co. for 14 years); also smaller offices and rooms for light manufacturing; rents low. Knapp Building, 41 and 43 Maiden Lane, New York.

**TO LET** for manufacturing purposes, upper floor N.W. corner Maiden Lane and Nassau St., 25x50 feet; elegant light; cheap rent; five H. P. electric motor now in operation; also work benches and fittings if desired; just the thing for manufacturing jeweler. Inquire of H. Kohlbusch, Sr., balance manufacturer, 59 Nassau St., New York.

### Miscellaneous.

**WHEN WANTING** a good lathe, remember the "Moseley"; there is none better, many not as good; their reputation has been built up by good design and good workmanship with very little wind; wind alone will not do it; send for our new illustrated circular. When interested, write your jobber, or Moseley Lathe Co., Elgin, Ill.

### TO RENT in Silversmiths' Building, CHICAGO.

A fine office on Wabash Avenue front, with north and east light, 20 x 42 feet, adjoining the Gorham Mfg. Co.'s salesroom on the sixth floor. Most desirable location in the city. For terms apply to

#### GORHAM MFG. CO.,

Silversmiths' Building, CHICAGO.

### SALESMAN to travel south

wanted with an up-to-date line of medium price Solid Gold Jewelry (Diamond set, &c.), extensive line of Sterling Novelties and high-grade Gold-Filled Vest Chains, Lorgnette Chains, Dumb-bell Links and Brooches. Salary, \$2,000 and expenses. Don't answer this unless you have established trade south, and can furnish high-grade references.

Address with particulars, "WIDE AWAKE,"

Care of JEWELERS' CIRCULAR.

## FOR SALE. TO CLOSE AN ESTATE. A jewelry business in one of the brightest towns in Wisconsin. An excellent business opportunity. Capital required about \$3,500.

Address, TOWLE MFG. CO., 149 State St., Chicago.

# HOLIDAY SELLERS—ORDER EARLY.



No. 65, Gents' Set. Pair Sterling Mounted Ebonoid Military Brushes and Sterling Top Comb, \$2.12, complete. Illustration one-half size. Foxwood Brushes, "New," same price.



No. 67, Gents' Set, for traveling. Real Leather Case, with pair of Ebonoid Sterling Shield Brushes, \$2.00, complete. Pair Brushes only, \$1.50. A Big Seller. Foxwood Brushes, "New," same price.



No. 75, Toilet Set. Wood Hinge Top Case, \$5.00 each. Paper Case, \$4.50. Hair Brush only, \$3.75. Comb only, 50c. Illustration one-third size.



No. 78, Toilet Set. In Wood Case, \$9.50. In Paper Case, \$9.00. Mirror only, \$5.50. Hair Brush only, \$2.50 each. Same set, with Ring-Handle Mirror, \$1.00 each less. Ring-Handle Mirror only, \$4.50 each. Illustration one-third size.

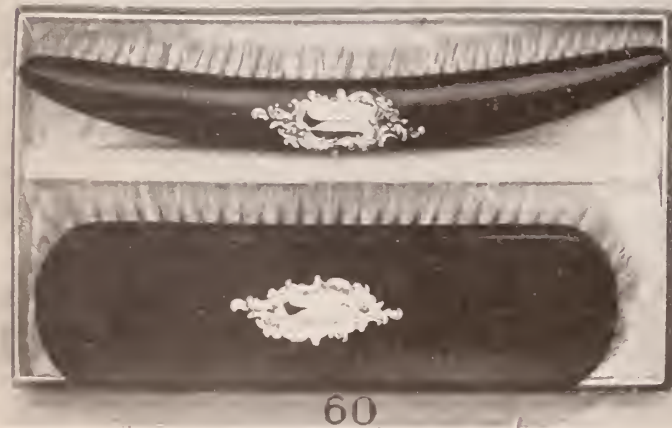

No. 60, Cloth and Hat Brush. Set Ebonoid Brushes, Sterling Shields, first-class Bristles, \$1.87, set complete. Illustration one-half size.



No. 82, Manicure Set. Scissors, Buffer, Vaseline Jar, Hook, File, Cuticle, \$3.00 each. Illustration one-third size.

Prices net less 6% for Cash. Consult Catalogue for other Sellers.

**AVERBECK & AVERBECK,**  
Manufacturers, 19 MAIDEN LANE, NEW YORK.

F. Bauer, Salina, Kan., has sold real estate valued at \$250.

C. Goldstein, Dallas, Tex., has been sued on a debt amounting to \$51.

J. A. Meeker, Chanute, Kan., recently sold real estate valued at \$1,000.

M. H. Kennedy is selling out his stock of jewelry in Erie, Kan., at auction.

W. E. Smith has given a bill of sale on his fixtures, tools, etc., in Sedan, Kan.

Charles E. Lovelace, Bolivar, Mo., has given a mortgage on stock and fixtures for \$475.

A. Hallberg will remove his stock from the old location in Belt to Great Falls, Mont.

John Ryburg, Seneca, Kan., has given a chattel mortgage on tools, furniture, etc., for \$60.

A. T. Claypool has discontinued the jewelry business in Bolivar, Mo., and moved to Springfield, Mo.

Chas. A. Cantwell, Malone, N. Y., has had his store redecorated and papered in bright and cheerful colors.

A. H. Gordon, Middletown, N. Y., left last week to enter the employ of Greenleaf & Crosby Co., Jacksonville, Fla.

Fred L. Hall, Carthage, N. Y., has recently placed in his store a 10 foot "double

deck" show case lighted by incandescent electric lights.

E. K. Kitchen, formerly with E. W. Wade, Chatham, N. Y., has accepted a position as watchmaker with Walter Ware, Waverly, N. Y.

Leopold Schneider, Brushton, N. Y., has improved his store by the addition of a handsome new oak show case and a new burglarproof Cary safe.

Gid Ralston, of Sebewa, Mich., has purchased John A. Campbell's jewelry stock, Portland, Mich. Mr. Campbell will do repair work for Mr. Ralston.

W. C. Tomlin, Enid, Okla., last week made a trip to Shawnee, Okla., for the purpose of looking over the G. S. Calhoun stock, with a view to purchasing.

Chas. E. Palmiter, Watertown, N. Y., has invented a new reflector for acetylene gas bicycle lamps, which adds very much to the powerful effect of the light.

J. S. Ross, of Sutton, W. Va., and his brother, J. B. Ross, Summersville, W. Va., have formed a copartnership and will open a jewelry store in the latter place.

Ed. L. Heaton, Canton, N. Y., and C. E. Haywood, Potsdam, N. Y., have been enjoying an outing in the North Woods just previous to the end of the Fall season.

Walter Vail, Deposit, N. Y., is exhibiting in his show a pumpkin weighing over 60 pounds, which was raised in his own garden.

We are pleased to note the convalescence of Emmett VanSickle, Port Jervis, N. Y., who has been confined to his bed for the past three weeks, after having undergone a severe surgical operation.

A. M. Felson, Gouverneur, N. Y., has invented a new needle threader, which is a marvel of accuracy and simplicity, and which should find a ready sale. He has also invented a pencil or pen holder which is of the simplest and most perfect mechanism.

A. J. Tulian, jeweler in the employ of H. A. Harrison, Sault Ste. Marie, Mich., has left for New London, Wis., to assume the management of Geo. R. Strickland & Co.'s jewelry store. E. J. Kiefer, now with the H. B. Shellito Jewelry Co., will succeed Mr. Tulian at Harrison's.

The final step toward securing the Wadsworth Watch Case Co. for Dayton, Ky., was taken Nov. 14, when the lease for the property of the Victoria Cordage Co., Dayton, whose buildings they are to occupy, was signed. They will remove their plant to Dayton about June, 1900.



Sterling, No. 28 \$10.50 doz. Gilt Lined.



Sterling, No. 93 \$12.00 doz. Gilt Lined.



Sterling, No. 98 \$12.00 doz. Gilt Lined.



Sterling, No. 25 \$12.00 doz. Gilt Lined.



Sterling, No. 32 \$7.50 doz. Special.



Sterling, No. 45 \$9.50 doz. Gilt Lined.

"Fountain Head of Good Values." **SOLOMON BROS. & GROSS.** *The Sterling House* "Makers of Trade Winners." 37-39 MAIDEN LANE, N. Y.

Makers of the most extensive line of

# Sterling Silver Novelties

ON THE MARKET.

## SOLOMON BROS. & GROSS,

MANUFACTURING

SILVERSMITHS AND JEWELERS,

37 and 39 MAIDEN LANE,

NEW YORK.

Telephone, 1701 Cortlandt.

Factories, Newark, N. J. Providence, R. I.

### Connecticut.

Samuel Phillips, Stamford, has enlarged his store by hiring the store adjoining and taking out the partition.

The Atlas Silver Factory, North Ave., Bridgeport, was destroyed by fire Nov. 16, causing a loss, it is reported, of about \$10,000; partially insured.

The C. B. Barker Mfg. Co., who lately purchased the Baldwin & Lamkin shoe factory, Milford, have a force of men at work remodeling the shafting.

Gen. Geo. H. Ford, New Haven, is by request preparing a valuable historic article for the *Connecticut Magazine* regarding New Haven's founding and history.

Jeweler J. C. Tracy, Willimantic, has added to his force Louis B. Lincoln, who has resigned from a position in the Willimantic post office to accept Mr. Tracy's offer.

M. J. Garfinkel's jewelry store, Hartford, was broken into about 1 o'clock Nov. 18. Entrance was effected by forcing the door in the rear. A small amount of jewelry was stolen.

The jewelry and notion store of Joseph Dulbus, 369 Water St., Bridgeport, was burglarized last Tuesday night. When he opened up his establishment he missed three watches, two of gold and one of silver, a long neck chain, two gold rings and a number of minor articles of lesser value.

It is quite possible that in the near future a new feature will be added to Bristol's already large clock business. W. F.

Brainard is the promoter of an attempt to organize a new company for the purpose of manufacturing clocks to contain an electric movement that has been but recently patented.

The officials of the New Haven Clock Co. have made changes in several departments of the factory which are taken by the employes to mean that the contract system is to be re-established. About seven years ago the company abolished the system, making many of the contractors foremen.

A. Randall Davidson, jeweler and optician, Ansonia, will on Dec. 1 occupy a new store at 124 Main St., now in process of erection. The location is unsurpassed in the city, being within four doors of the post office. All fittings of the store will be new and the store will be much more extensive than the store Mr. Davidson is vacating.

### The Supposedly Lost Trunk of O. R. Ryan Recovered.

CHICAGO, Ill., Nov. 25.—The supposedly lost trunk of the Towle Mfg. Co., carried by their Mr. Ryan at the time of his sudden death at Oshkosh, Wis., which it was presumed had been shipped ahead by him just previous to his death, has been recovered. W. C. X. Hull, who had taken up the unexpired trip of Mr. Ryan, wired the house Thursday that the trunk had been found with contents intact. Details are lacking, but it is probable that the information that the trunk had been shipped from Oshkosh was incorrect.

### Trade Gossip.

Theodore Neuhaus & Co., Cincinnati, O., are making up an order for loving cups on a magnificent scale.

The Atlas Watch Co., Chicago, report their product sold up to Jan. 1. There has been an unusual demand for Atlas movements, and they seem to just fill the requirement of the retail jewelry trade.

The Jewelers' Co., Cincinnati, O., are forging to the front as an exclusive ring house of the west. They make every variety of ring and have a reputation for carrying a large line of their own manufacture.

O. E. Bell, Cincinnati, O., says they recently made a contract for a large lot of diamonds, and will now push forward their plan relating to holiday rings, which depended on this contract. He expects in the next week to have on the market a fine and cheap line of diamond rings that will be a surprise to the trade.

The optical plant of Oskamp, Nolting & Co., Cincinnati, O., is becoming a noted feature with this house. It is in charge of Harry Emrie, who is one of the most experienced opticians in that section. They make their own specialties and do their own grinding and are prepared to fill all orders from the trade at very low prices with quickness and dispatch.

Louis Manheimer, Chicago, says in the 25 years he has handled watches he has never before seen the trade in any such condition as it now is. The demand is growing even now, and the supply is fast diminishing. What the trade will do for watches in December is a problem. Mr. Manheimer says he has for some time past and now is buying everywhere he can get them to even fairly supply his customers.

Mathews & Prior, silversmiths, 245 W. 28th St., New York, who make a specialty of supplying only the legitimate jewelry trade, are becoming noted for the many new ideas and novelties which they have been adding to their various lines. Among the latest creations of this firm which will prove desirable in a jeweler's stock of holiday presents are some novel cigar lamps, cigar rests, match stands and complete smoker sets.

### A Novelty in Locketts.

WITH a considerable portion of a man's nasal septum in his pocket, James D. Hughes, a manufacturing jeweler, returned from Carlisle yesterday and will make a locket which a battle scarred football hero will wear as a trophy. It seems that a member of the Dickinson College team had his scalp plowed open by a member of the eleven representing Pennsylvania College at Gettysburg. The Gettysburg player who did the plowing overlooked a portion of the bridge of his nose, which the surgeons afterward extracted from the scalp of the Dickinson College man, and the latter appropriated it as a legitimate spoil of war. The locket, when done, will take its place beside trinkets fashioned out of human skin and the small bones of the ears, fingers and toes, all of which are numbered among the proud possessions of freshmen in medical colleges.—*Philadelphia Record*, Nov. 19.



## Our New.... Jewel Case



has been pronounced  
by competent judges  
the best in size, shape,  
workmanship and fit-  
ting, in the market.

**Roy Watch Case Co.,**

Makers of **SOLID GOLD CASES,**

21 Maiden Lane,

New York.



TRADE-MARK REGISTERED.



**Miss L. A. Rosenthal, "South Carolina's Lady Optician," Opens Her Parlors.**

CHARLESTON, S. C., Nov. 21.—Yesterday afternoon at 5 o'clock the large and handsome optical store of Miss L. A. Rosenthal, in the Masonic Temple, next to the corner of Wentworth St., on King, were opened. The large plate glass windows were tastefully dressed, one with fine optical goods and the other with cameras and photographic supplies. The goods were



MISS L. A. ROSENTHAL.

displayed on white pyramids, with Nile border, and green brocaded silk hangings.

The main store is handsomely papered in gold and colors, with a rich border, and the shelving and wall cases are finished in white enamel and gold. On one side the counters are white, with green felt tops; on the other side quartered oak, surmounted by beveled plate showcases. Comfortable, leather seated oak chairs stand at intervals on the linoleum, and flowers, ferns and pictures are everywhere.

A portiere of beads and bamboo cuts off the store from the testing room for optical work. It is Oriental in design. Further on are stock rooms, dark rooms for developing photographs, etc. The store and stock rooms are filled with optical goods, artists' supplies, cameras and photographic supplies.

Miss Rosenthal advertises and is known as "South Carolina's Lady Optician."

Her friends applaud her for her indomitable pluck and perseverance in adopting such a useful profession and winning success in it. Barely 18 years of age when her father, Ernest Rosenthal, optician and jeweler, died after a very short illness, in May, 1894, she, in conjunction with her sister, Beatrice, who was nearly four years younger than herself, came to a conclusion to try and keep up the optical branch of the business and to do all in their power not to become incumbrances on their widowed mother. Miss Rosenthal very soon made a journey to New York and placed herself under the personal tuition of Dr. Julius King. She remained there several months, studying very hard and diligently, so that she was enabled to pass her examination, receiving her diploma. She returned to New York on four other occasions—each time studying and attending lessons and lectures.

**Birmingham, Ala.**

**TRADE CONDITIONS.**

Business during the past week has been especially good in and around Birmingham, caused by the Alabama State Fair, which had been in session for 10 days. Some 3,000 strangers were brought here each day, and they took advantage of the occasion to do a bit of holiday shopping. Local jewelers have sold quite a number of Christmas presents to people who will not be able to get back for the holidays.

J. T. Adams, Jr., Talledega, now carries optical goods.

C. T. Blaum has opened a new jewelry store at Dothan.

J. W. Hollan has opened a stock of optical goods at Troy.

Davis Jewelry Co., Tuscumbia, have enlarged their business.

Dr. F. H. May has opened a stock of optical goods at Huntsville.

J. E. Whitten has opened a jewelry stock and repair shop at Ensley.

W. T. Bell, jeweler for E. Lowensohn, has returned from Ozark, with his bride.

J. T. Tarner is now at Hartselle, where he has put in a big stock of general jewelry goods.

I. Dahlheimer has been closing out the stock of the Palace Jewelry Store, Mobile, at auction.

John A. Humphries has opened a jewelry stock in the store of the Freeman Drug Co., Ensley.

Rainey & Watkins, Alexander City, druggists, have added a line of jewelry to their business.

"Shelley, the Jeweler," has opened at Eufaula with a good stock and arrangements for repairs.

A. C. Colley has opened a stock of jewelry in Wetumpka, Ala., in the same building with McD. Cain.

A. W. LeBron, Montgomery, has become watch inspector of the Louisville and Nashville Railroad in that territory.

William Rosenstihl, former member of Rosenstihl Bros., and secretary of the Alabama Retail Jewelers' Association, has gone with Harry Mercer.

F. S. Jobson, manufacturing jeweler, has added to his business the grinding of instruments and the hollow grinding of razors. J. P. Goesser has charge of this department.

E. F. Herzog, with Harry Mercer, who lost his wife 10 days ago, has returned to his duties. Mrs. Herzog was only 19 years of age. A little baby boy is left motherless.

Herman Jonas and Solomon Jonas were here last week. The former is with Pfaelzer Bros. & Co., Philadelphia, Pa., and the latter with I. W. Friedman, New York. Both reported business fine in the south.

C. C. Buder, of Buder Bros., Columbus, Miss., whose business is largely in Alabama in the towns nearby, is east this week purchasing a stock. The wholesale end of the Buder establishment is now being pushed.

William Rosenstihl, Jr., who has been at Union Springs for a few days, has returned. While at Union Springs Mr. Rosenstihl interested the Board of County Commissioners in a proposition to place a clock in the court house tower there.

M. F. Doering, the jeweler at Anniston, who presented Admiral Schley with a spoon while the Admiral was in the south, has received the following letter in the handwriting of the Admiral himself:

"The Everett,  
WASHINGTON, D. C., Nov. 10, 1899.  
"Dear Sir—Very many thanks for the kind gift of the souvenir spoon, which I appreciate highly and which I shall always keep in memory of a most delightful visit to the south.

"Very truly yours,  
"W. S. SCHLEY.  
"Mr. MAX F. DOERING,  
"Anniston, Ala."

"Our concern has turned out 400,000 watch cases the current year," said Joseph T. Brennan, of the Dueber Watch Case Mfg. Co., Canton, O., at the Knutsford to a Salt Lake (Utah) *Tribune* reporter, Nov. 14, "and the demand for watches all over the country has been so great that recently the factory wired me to return the stock that I carry with me as it had all been sold. We employ 3,600 hands, and our daily production is from 1,500 to 1,800 watches. The total frontage of the factory is equal to eight blocks of the city of Canton. People seem to be buying watches all over the country, and, in fact, with the prevalence of good times under a Republican administration, people have the money to spare for this purpose."

The  
**Mercantile National Bank**

OF THE CITY OF NEW YORK,

BROADWAY AND DEY STREET,

Solicits Accounts from the Jewelry Trade.

THE WESTERN JEWELERS' CIRCULAR SUPPLEMENT

THE JEWELERS' CIRCULAR

THE GREAT WESTWARD TAKES ITS WAY

VOL. XXXIX.

NEW YORK, WEDNESDAY, NOVEMBER 29, 1899.

No. 18.

**Chicago Notes.**

All communications in reference to the Chicago department of The Jewelers' Circular, addressed to Stephen Parlin, 1522 Lill Ave. (Telephone, Lake View 397), Chicago, will receive prompt attention.

President Hulburd, of the Elgin National Watch Co., is in the east.

A. S. Holly, of the Towle Mfg. Co., has returned east from his visit here.

C. R. Eveson, Anderson, Ind., was here last week on a buying trip that consumed three days.

A. L. Sercomb, of the Meriden Britannia Co., returned Monday from a 10 days' visit at the factory and New York.

Miss Lelia Green, for a number of years with Lapp & Flershem, has accepted a place with B. F. Norris, Alister & Co.

H. G. Nye, Chicago manager for C. Rogers & Bros., is on an extended eastern trip, covering the territory as far east as Pittsburgh, Pa.

W. J. Miller, manager in Chicago for the Seth Thomas Clock Co., is back from New York. S. C. Payson, traveler for the company, has also returned from the same city.

John Messing, Burt, Ia., was one of the largest buyers of the past week. Mr. Messing is a discriminating buyer and knows well the requirements of his customers.

W. H. Vogell, of Alfred H. Smith & Co., returned to Chicago Wednesday from his visit to the New York house, and said business with them both east and west is excellent.

Three bill clerks and several house salesmen were added to Otto Young & Co.'s forces the past week, the addition to the force being necessary to promptly get the orders on the way to the buyer.

F. W. Hauenstein, New Ulm, Minn., who, besides being proprietor of a fine store also represents the J. W. Tufts lines, was in town last week. Mrs. Hauenstein has quite recovered from the serious burning she received nearly two years ago.

The working force in A. C. Becken's salesrooms has been added to till fully 50% more people are employed than he had a year ago, which gives an air of greatly increased activity, for the requirements on each individual, despite the larger number, seem to have increased even more rapidly than has the force.

A meeting of the banquet committee of the Chicago Jewelers' Association, was held Tuesday of this week, all the members

of the committee having returned to the city, and an outline of the work to be accomplished was decided on. According to the preliminary arrangements the jewelers have a treat in store for the latter part of January.

G. A. Rogers, optical expert, has accepted a professorship in the Chicago Ophthalmic College and will fill the chair of optometry. Dr. H. M. Martin will move the college, Dec. 1, from W. Van Buren St. to large and handsome quarters in the Stewart building, northwest corner State and Washington Sts., a central location of greater convenience to the students.

Stein & Ellbogen Co. last week finished the cutting of the largest diamond that ever passed through their diamond cutting works, a 25 $\frac{3}{4}$  karat stone of perfect form, absolutely pure white and free from any blemish whatever. As a centerpiece for a tiara or corsage or necklace of large stones, it is a rare gem that is destined some day to become a valued heirloom.

Buyers here for the past week included the following: E. W. Trask, of Trask & Plain, Aurora, Ill.; J. W. Neasham, Ottumwa, Ia.; W. J. Gamm, Madison, Wis.; D. T. Greene, Lafayette, Ind.; W. W. Woolley, Streator, Ill.; F. W. Wilson, Centre Point, Ia.; J. R. Pitts, Lockport, Ill.; S. H. Clausin, Minneapolis, Minn.; Edward Rathke, Maysville, Minn.; A. J. Leach, Casson, Minn.; A. W. Nisbitt, Diamonddale, Ill.; A. M. Smythe, Elgin, Ill.; John Becks, Michigan City, Ind.; E. Pearson, Princeton, Ill.; Thomas S. Lockhart, Kenosha, Wis.; L. H. Bauer, Elgin, Ill.; R. P. Kiep, Joliet, Ill.; F. C. Sheldon, Shelbyville, Ind.; E. J. Born, Ashland, Wis.; E. L. Thayer, Rockford, Ill.; R. E. Brackett, Lansing, Mich.; John Messing, Burt, Ia.; Emil Fink, Elgin, Ill.; C. R. Eveson, Anderson, Ind.; F. W. Hauenstein, New Ulm, Minn.; Iran Clark, Sterling, Ill.; Mr. Wykkel, of Pyl & Wykkel, Kalamazoo, Mich.; J. Schneider, McHenry, Ill.; W. J. Dick, Watseka, Ill.; A. L. Griffin, Potomac, Ill.; A. S. Staubenbiel, Dubuque, Ia.; J. W. Van Dorn, Miononk, Ill.; Howard Williams, Delavan, Wis.; C. J. Peterson, St. Charles, Ill.; W. P. Yeoman, Waukegan, Ill.; A. E. Henry, Rockford, Ill.; C. L. Rost, Crawfordsville, Ind.

W. W. Titley, who had a jewelry store at 1220 $\frac{1}{2}$  Seventh Ave., New Brighton, Pa., has sold his stock and will go to West Virginia to engage in religious work. He belongs to an order called the Evening Lights.

**Cincinnati.**

**TRADE CONDITIONS.**

There was a revival of business the past week among jobbers. Retail jewelers were arranging their Thanksgiving displays and expected a spurt in trade during the week. The factories are unusually busy, order and repair work coming in with every mail. There never were so many diamond sales in this city as during this month.

S. W. Rookard, Jellico, Tenn.; J. C. Bailey, Hampden Junction, O., and John Kennard, Rushville, Ind., were in town last week.

S. Labusher, road representative of the Bell Watch Case Co., is home from an extended western trip, and said he made the biggest sales since his connection with the house.

L. Gutman left on Monday, Nov. 20, with Mrs. Gutman on an extensive southern trip. They will spend some time at Atlanta and other points in Georgia, and will go thence to Florida, where they will remain until about the time of the holidays.

**Omaha.**

H. L. Stanton, manufacturer of silk watch guards and eyeglass cords, Chicago, called upon the retailers Thursday.

Mike Treusch, Louisville, Neb.; A. B. Park, Waterloo, Neb., and M. Hartzstein, Talmage, Neb., were purchasers in the city last week.

The B. H. Stief Jewelry Co., Nashville, Tenn., have secured an injunction against Sosnoski, furrier, alleging that he is about to remove his goods from Omaha.

"Shanty" Campbell, one of the boys who broke through the window of the Columbian Optical Co. and stole several articles, was released by the Judge, with the understanding that he would be sent to the reform school if he repeated the offense.

Chas. Garlick, representing Theo. Schrader & Co., Chicago, and who has been traveling through Omaha for over 20 years, was in the city Thursday. He had a handsome display of opals, and left on exhibition with McComb what is claimed to be the largest opal of its purity and color in this country. He reports to THE CIRCULAR that the demand for jewelry on this trip through the west is very heavy and for better goods than of recent years. Especially he has noted the demand for diamonds, notwithstanding the higher price.

"If that ain't enough I'll steal something else, but I'm bound to get in the pen," were the words of Micky Kroll, an ex-convict, when he was caught after stealing a gold watch from Mawhinny & Hol-

liday's. He called at that establishment Wednesday morning and asked to be shown a gold watch. A tray of watches was placed before him and, snatching one, he ran to the door. The alarm was given at once and a crowd followed the thief. When a block away he stumbled over a messenger boy and fell into the arms of an officer. Kroll is looked upon by the police as a rare specimen in criminology.

The Columbian Optical Co., who now have large houses in Omaha, Kansas City and Denver, will open a fourth in Des Moines, Ia., the first of January, 1900. They have rented a suite of four rooms in the new Crocker block, which will give them 1,800 square feet of floor space. One room will be used as a store room, one for reception, a third for testing eyes and a fourth for grinding and prescription work. A \$7,000 stock has been purchased, and this establishment will be the second, if not the largest in the State. E. H. Reese, formerly of Omaha, but now of Chicago, will be the manager, and Charles Cowan, of Omaha, will be in charge of the mechanical department.

Albert Edholm has picked up what he believes is a family heirloom which had been stolen and which the owner would be glad to recover. It is a heavy 20 karat gold seal mourning ring. The stone is black onyx, and upon the face is evidently the crest of some family. Encircling a fox head is a ribbon, in which is sunk backward, so as to appear correctly when used in sealing, the motto, "Qui Caput Capitur." The inside of the ring bears the inscription:

"David Smith, died May 27, 1877, aged 58 years. Jane Cunynghame Dick, died Sept. 23, 1875, aged 41 years. R. I. P."

The ring was picked up in a pawn shop in Chicago and brought to this city by a gentleman who traded it to Mr. Edholm.

## Pittsburgh.

### TRADE CONDITIONS.

Everything points to a lively holiday trade. Dealers have taken on the customary addition of relief clerks, and holiday sales are now on. Despite the high prices which diamonds now command, this commodity has been having an unprecedented demand. Silver novelties are the usual favorite and first seller, but the call this year is for first-class goods.

A. J. Sheff, for A. E. Siviter & Co., came in last week from a three weeks' successful tour.

Steele F. Roberts has returned from a trip to New York for holiday goods and an incidental visit to the Horse Show.

Jacob Grainer, of Grafner Bros., is making a business trip through Cumberland, Md., Uniontown, Connellsville and other towns.

A. E. Siedle, proprietor of the new Market St. store, has improved the East End main establishment by making it larger and adding new fixtures.

A runaway horse belonging to Squire Louis Holtzman, of Braddock, Pa., ran away on Friday afternoon, and dashed into the display window of John Yenny's jewelry store, 910 Braddock Ave. About \$500 worth of holiday goods was destroyed, and three large plate glass windows broken.

Samuel Horowitz is charged before Al-

derman J. F. Madden with larceny by bailee. It is alleged by Mrs. Mary Bryan, of Chartiers township, that she took a clock to Horowitz to have repaired and that when she called for it he refused to give it to her. A warrant was issued. Mr. Horowitz's troubles are accumulating.

On Nov. 20, Common Pleas Court No. 1 issued a *capias* for Mattie Carson, a young woman, charged with neglecting to pay rent for a pair of diamond earrings. The writ was issued at the instance of Aaron B. West, jeweler, Eichbaum building. When the girl leased the earrings a price of \$385 was set on them, and when she had paid enough rent they were to be hers. Mr. West says that only \$15 has been paid.

Mrs. Emanuel De Roy, of Smithfield St., notified the police of the loss of a diamond ring and brooch, valued at \$2,000. She had been visiting her daughter in Newark, N. J., and lost her diamonds on the train from Newark to Philadelphia. She carried them in a small bag which she supposes she dropped. Mrs. De Roy does not think that she was robbed. Mrs. De Roy is personally interested in the store on Smithfield St.

Al. Andrews, of Heeren Bros. & Co., met with a painful accident on Friday. While endeavoring to pass another person behind the counter, he was accidentally jostled against a plate glass door, which was utterly demolished. Mr. Andrews' hand was badly cut. A few moments previous a large electrolier hanging from the ceiling came down unexpectedly and was smashed on the marble floor. Fortunately no one was near at the time of the occurrence.

One of the local travelers in until after Thanksgiving gives the following information: W. G. Spies, Steubenville, O., has fitted up two rooms in the second story of his building for music boxes and a complete optical department. His two daughters, the Misses Lulu and Marie, recently graduated from an eastern school, Miss Lulu as an optician and Miss Marie as an engraver. Both departments will be under their direct supervision. John A. Slonecker, Scio, O., has removed to his handsome new building on the same street in Scio. The store is the handsomest in the booming oil center, with tiled floors, hardwood fixtures, etc.

Out-of-town jewelers in the city last week were: E. H. Kennerdell, Tarentum, Pa.; R. L. Kirkpatrick, Butler, Pa.; L. C. Brehm, West Newton, Pa.; George V. Brady, Washington, Pa.; R. H. Wolf, Smithton, Pa.; D. W. Hull, Warren, Pa.; J. C. Keith, Ellwood City, Pa.; T. N. Smith, Morgantown, W. Va.; L. B. Mather, New Castle, Pa.; A. V. Johnston, Evans City, Pa.; Carl H. Leighner, Butler, Pa.; M. E. Shutterly, Mt. Pleasant, Pa.; P. J. Manson, Jeannette, Pa.; H. R. Brown, New Brighton, Pa.; F. W. Laban, Steubenville, O.; L. G. Coll, Waynesburg, Pa.; A. C. Gaul, Sharpsburg, Pa.; Charles A. Loughman, McKee's Rocks, Pa.; A. Teplitz, McKeesport, Pa.; J. C. Rhodes, Homestead, Pa.

H. B. Lindsey is a new jeweler in Orrick, Mo.

## St. Louis.

Goodman King, of Mermod & Jacard Jewelry Co., is out of the city for a few days.

Charles Derleth, East St. Louis, Ill., is making extensive improvements to his store and increasing his stock.

The St. Louis Jewelers' Supply Co. have been incorporated. Capital stock, \$2,000. Incorporators: B., F. J., L. and J. P. Kersting.

F. W. Drost, Fullerton building, has rearranged his show cases in his beautiful store. The improvement effected thereby is great, and is done in anticipation of the holidays.

The engagement is announced of Miss Gertrude Heyman to Ike Felsenthal, Galena, Kan. Miss Heyman has been connected with the Bauman-Massa Jewelry Co. for some years.

Out-of-town jewelers here last week: J. O. Warren, Muscogee, I. T.; Chas. Mauth, of Mauth & Adams, Marshall, Mo.; C. H. Gieseke, Trenton, Ill.; Fred Herold, Jerseyville, Ill.; Albert Pfeifer, Little Rock, Ark.; M. G. Wolff, Chester, Ill.

## Columbus, O.

Haines & Oberer have put in a large stock of fancy leather goods for the holiday trade. They are making a handsome display of this line.

William B. Tucker has opened a store and repair shop on the viaduct. This makes three stores on the viaduct within a square of each other.

J. M. Hockenberry, jeweler, Newark, and Miss Iva Myrtle Colville, daughter of Newton Colville, were married Wednesday evening, at the home of the bride's parents.

Albert H. Bonnet, one of the best known wholesale men here, says he has sold more goods and of a better quality this season than ever before. He is well satisfied with the business, and thinks the jewelers everywhere will have the best season's business they have enjoyed in many a day.

J. B. White will after the first of the year devote his whole time and attention to the optical business, and will close out his jewelry stock altogether. He will put in a large stock and will do a wholesale as well as retail business. This will make two large optical houses for Columbus, the other being that of the H. Cole Co.

Bancroft Bros. have been adding to their capacity again and are now in good shape for the holiday trade. They have placed another fine oak wall case in their store and another bench in the working department. Two additional men have been employed and they are ready for the rush. They have two engravers who will do nothing else but work on the goods that are sold for holiday purposes.

E. Lerew, Hamburg, Ia., has purchased a building east of the post office and will improve and remodel it for a jewelry store.

Alf Wissing, jeweler, Sioux City, Ia., who has sold his lease of the store he now occupies at 603 4th St., will move Jan. 1 to 625 4th St.

**Detroit.**

W. H. Mitchell, of Middleville, Mich., has opened a new jewelry store at Sparta, Mich.

R. Loughlin, Port Huron, Mich., has opened a repair shop at 277 Michigan Ave., that city.

J. A. Selling & Co., wholesale jewelers, Hammond building, will shortly remove to 125 Jefferson Ave.

G. W. Johnson, formerly a jeweler on Grand River Ave., has entered the employ of Montgomery Ward & Co., Chicago.

A. E. Tucker, Cass City, Mich., closed up his jewelry business there and is now located at Bad Axe, Mich., in the same business.

Chas. Graves has purchased the jewelry stock of C. S. Graves, Bad Axe, Mich.; also the jewelry stock of W. B. Godfrey, Bay City, Mich. He will probably consolidate the two into one stock at the latter city.

W. E. Dennis, an optician at Mendon, Mich., who came to Michigan from Philadelphia six years ago, announces that he was called to Chicago last week, where he found that he was a real Irish lord and that he has unlimited funds at his command.

Ira D. Lane, Bad Axe, and C. G. Draper, Plymouth, were the only Michigan country buyers here last week.

**Pacific Northwest.**

E. B. Wheat will open up a jewelry store in Arlington, Ore.

Reeves & Prindle have opened a new jewelry store at Fossil, Ore.

John Locke, a jeweler, formerly of Seattle, was in Grant's Pass, Ore., last week.

A. J. Douglas, optician, formerly of Seattle, Wash., has just returned from Alaska to Seattle, where he will locate for business.

John Hermann, who robbed Henry Rehnke & Bro.'s jewelry store, Ellensburg, Wash., was sentenced to 10 years in the penitentiary.

J. H. Leyson, Butte, Mont., has returned from an extended trip to the east. He visited Boston, New York, Washington, Chicago and St. Paul.

A. A. DuBois, who was for a time associated with M. F. Johnson in the jewelry business at McMinnville, Ore., has removed to Kansas.

C. H. Tempel, jeweler, has purchased a building at Hood River, Ore., and will have the place remodeled and refitted for his jewelry business.

W. A. Ingalls, South Bend, Wash., left for San Francisco last week to lay in a complete stock of jewelry and silver ware for the holiday trade.

An attempt was made recently to burglarize the jewelry establishment of M. Copinus, Wardner, Idaho. The burglars

were unsuccessful in effecting an entrance.

Chas. Robinson's jewelry store, Cordon, Wash., was entered by robbers one day last week between 8 and 10 o'clock A. M. and about 20 watches were stolen. There is no clue to the thieves.

P. O. Borg has purchased the Garrigues building, Heppner, Ore., and after the same is remodeled, he will move his jewelry store therein, which will afford him a great deal more room than at present.

M. L. Vial is now located in his handsome new block at Weiser, Idaho. He has ordered a new wall case and several more handsome show cases and, to make up the display therein, he is more than doubling his stock of musical goods and jewelry. He will also put in a fine line of silver ware.

**Kansas City.**

Chas. Lasky, 1019 Main St., is disposing of his stock at auction.

W. J. Gurney and Thos. Ware, two well known business men of this city, being formerly with Cary & Olmstead, have opened a new store at 1005 Walnut St. They have an elegant location, handsome trimmings and have laid in a very complete stock.

Since the return of the 20th Kansas Regiment from the Philippines the Streicher Watch & Jewelry Co. have received and completed orders for 907 medals for the soldiers, to be given by the citizens. The medals given by the people of La Cygne to its heroes are about as large as \$20 gold pieces. On one side are crossed rifles and the legend, "Twentieth Kansas Heroes," and on the reverse is engraved, "Co. D, Manila, P. I., 1899; presented by citizens of La Cygne, Kansas, Nov. 21, 1899."

Grant I. Rosenweig, attorney, went to Jefferson City last night to assist in arguing before the Supreme Court that the department store act, passed by the last Legislature, is unconstitutional. The first case to be argued went up from St. Joseph. There the department store managers were arrested as they were here, and they appealed to the Supreme Court. By invitation of the St. Joseph attorneys, Mr. Rosenweig, who is attorney for the Doggett Dry Goods Co. and for John Taylor, appears in the case.

**Indianapolis.**

Sam Sterchi, of S. Sterchi & Co., Terre Haute, Ind., is quite ill at a hospital in that city. Chas. Williams is also on the sick list.

Among the buyers in the city last week were: Claud Bishop, of G. W. Bishop's Sons, Walton, Ind.; Wm. Drake, La Rue, O.; H. L. Rost, Columbus, Ind.; Washburn Jewelry Co., Anderson, Ind.; Miller Bros., Middletown, Ind.; August Anderson, North Salem, Ind.; J. M. Tryon, Monroeville, Ind.; A. W. Owen, Greenwood, Ind.; E. A. Wiley, Morrisville, Ind.; A. Pursel, Nobleville, Ind.; G. S. Drake, Pendleton, Ind.; Mr. Dressler, of Dressler & McCann, Bowling Green, Ind.; Kemper Bros., Greentown, Ind.; F. G. Heinzl, Tell City, Ind. Mail orders have also been very plentiful, and travelers have sent in good orders.

**HAVE YOU SEEN IT!****The Maxine Oriental Band.****ENTIRELY NEW. SET WITH GENUINE CUT PARISIAN STONES.**

Rubies, Emeralds, Amethysts, Corals, Turquoises &amp; Sapphires.

**A PRONOUNCED PARISIAN FAD.**

Made of Sterling Silver, 925-1000 fine.

\$7.50 for the assortment of 6, or \$14.50 per dozen.

**The Fastest-Selling Bracelet ever shown.  
Order ½ dozen for a sample.**

They'll go like wildfire, at a good profit.

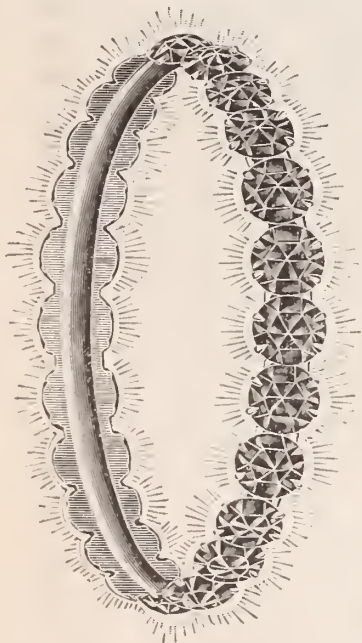
**IMPERIAL MFG. CO.,  
Masonic Temple, CHICAGO.****Georgian** STERLING SILVER.

In Complete Table Service—

French Gray Finish.

COFFEE SPOON.

**TOWLE** MANUFACTURING CO.,  
CHICAGO. NEWBURYPORT, MASS.

**Minneapolis and St. Paul.**

P. K. Wiser, Mankato, Minn., mourns the loss of his wife, who died last week.

G. M. Bennett, of Reed, Bennett Co., Minneapolis, is home suffering with inflammation of the bowels.

Fred Weidhoff, Minneapolis, has accepted a position as watchmaker with W. M. James, Breckinridge, Minn.

George F. Gage, formerly with Eustis Bros., Minneapolis, who has been east for some time, has returned, and for the present is associated with Charles D. White & Co.

Fred Fiske, Minneapolis, has gone to Omro, Wis., to attend the funeral of his brother, Elmer Fiske, who recently died in Arizona, and was taken to his old home for burial.

W. C. Haviland, agent for the Jersey Silver Co., with offices in the Boston block, Minneapolis, died last Monday, at St. Barnabas Hospital, Minneapolis. He leaves a wife and one son.

R. B. Ackerman, foreman of the Minneapolis Jewelry Mfg. Co.'s repairing department, has rented rooms at 39-41 3d St. S., and on Jan. 1 will resign his position with his present firm and engage in the manufacturing jewelry and repairing business for himself, the firm name being R. B. Ackerman & Co.

Zebulon S. Skinner has pleaded guilty to a charge of grand larceny in the second degree, but has not yet been sentenced. Skinner was employed by Eustis Bros., Minneapolis, as a clerk in their store, and was charged with having stolen jewelry from his employers. "Broker Braidy," a pal of Skinner, is on trial here this week.

The body of Frank Dailey, manager of the Northwestern Bottling Co., Minneapolis, was picked up on the St. Louis tracks last week, horribly mangled. Both of his legs were severed from his body and he was otherwise cut up. It is believed that Mr. Dailey fell over the embankment and was probably dead before being run over by a train. He was 57 years old, a veteran of the civil war, and had resided in Minneapolis for the past 30 years. He leaves a wife and three daughters. Mr. Dailey was formerly a member of the firm of Reed, Dailey & Bateman, and Reed & Dailey, wholesale jewelers, of Minneapolis.

**Elmira.**

Fred H. Rees, employed as a watchmaker and engraver at W. H. Frost's jewelry store, has been granted a patent on a spring lace hook for shoes and another on an automatic announcer of stations on railroad trains.

Cecil E. Chambers, watchmaker and engraver of Swarthout & Brooks's jewelry store, has been arrested on the complaint of his wife charging him with non-support. The affair has created a sensation here. Chambers pleaded not guilty to the charge and will fight his case to a finish.

Robert J. Knox, one of the bank draft swindlers under arrest in New York, is a former Elmira lawyer, having been a member of the firm of Knox & Herendeen. Knox is the son of a former Presbyterian

minister of this place. Five years ago the news came that Mr. and Mrs. Knox were in prison in Belem, Mexico, charged with having obtained \$10,000 worth of jewelry from a jeweler there on a worthless draft. The draft was drawn on Alonzo Whiteman, who then lived in Dansville, N. Y. Whiteman was one of the men recently arrested with Knox. Soon after their imprisonment both the Knoxes contracted typhus fever, and Mrs. Knox came near dying. Friends in Elmira and neighborhood raised nearly \$1,100 with which to employ counsel to defend the prisoners, but at the trial both were convicted. Knox was sentenced to two years' imprisonment and Mrs. Knox was fined \$500, which was paid by her friends.

**Louisville.**

Higgins & De Graw, formerly at 413 W. Jefferson St., have removed to 438 W. Market St.

James W. Sharrard has moved his store from 4th St. to 306 W. Market St., where he has more commodious quarters.

Wm. G. Buschemeyer, diamond setter and manufacturing jeweler, is now installed in new quarters at 325 Fourth Ave.

Wm. Kendrick's Sons must be credited with having one of the finest displays yet shown in Louisville at their holiday opening now in progress.

Max H. Griffin, long identified with the engraving trade, has opened a watchmaking and engraving establishment at 213 Fourth Ave. An exclusive engraving and watchmaking store is a new venture here.

**Another Victor.**

When the crucial test comes, when quality tells, side by side with the conquerors Olympia and Raleigh stands

**THE BOSTON.**

O size, 3 rows of pearls, made in Montauk, 20 years' guarantee, and 14 F.K., 25 years' guarantee.

**Joseph Fahys & Co.,**

Established 1857.

FAHYS BUILDING,

NEW YORK.

## VIEWS ON MERCHANDISING.

ADDRESS BY W. E. JENKINS, JEWELER, RICHMOND, IND., ON "CONCENTRATION AND SPECIALIZATION IN MERCHANDISING," BEFORE THE ECONOMIC LEAGUE.

### First Half.

AT the barter stage of commerce in the infancy of exchange the vendor, as distinct from the maker, did not exist. Every producer disposed of his production as fast as he accumulated an exchangeable surplus. In a more specialized stage of industry merchandising differentiated itself from manufacturing, and a distinct class of sellers grew up, those who dealt in the products of the labor of others. Possibly the first merchants were nomads or adventurers, who, in the course of their travels, made note of the coincidence of a surplus of a particular commodity in one locality with a scarcity of the same thing in another region, and equalized the two conditions to their profit.

The merchandising class has grown in importance with the progress of specialized and diversified industry, and it exists in obedience to economic law; that is to say, it is cheaper to contribute commodities in that way.

Of course, the merchant as a distinct industrial factor, did not come into existence at any distinguishable point of time. He was slowly evolved in obedience to the law of economy. Restrictive laws, prejudices, immemorial customs have retarded and modified, but they have not prevented, the development of the merchandising class. The function of distribution has progressively been discharged by more and more highly specialized agencies. At one time the shop owner or caravan master bought, transported and sold all manner of utilities. Now, in a general way, this work is divided between the common carrier, the wholesaler, and the retail merchant, with, in some cases, a sub-jobber and an importer taking part in the operation. Furthermore, each branch of this service has undergone a high degree of specialization.

The actuating cause of this development has been all along the same as that operating in the production of merchandise: namely, the stress of competition, escape from which could be had only through the obtaining of greater economy by means of increased efficiency. So along the lines of specialization of function or division of labor the evolution of merchandising has taken place—not at the same rate in all countries, and at all times, but to a degree corresponding to the general industrial plane reached at any particular time and in any particular country. For instance in remote and sparsely settled rural districts the general store yet survives along with the primitive method of barter, and in some cases the merchant acts as a sort of common carrier, transporting his own and the neighborhood's goods from and to the nearest railroad or steamboat line.

With a higher development of such localities comes about a greater specialization in merchandising, and a rudimentary classification of different kinds of merchandise in separate stores is attempted. With the further growth of the community a more definite classification appears,

and the stage is reached with which we are familiar in small towns, a more or less definite segregation in separate stores of the different kinds of merchandise. In older communities (such as the cities of Europe) where large populations had grown up prior to the rise of the factory system, the classification is most definite because, first, of the persistence of the more primitive condition in which the proprietor of the store makes on a small scale the things he sells; secondly, because of the former control of industry by secular guilds or societies, the regulations of which permitted a single trade to each man.

It was not until the early years of Queen Victoria's reign that trade was made free in English cities; so the prejudice against a mixing of lines of merchandise is simply the ghost of recently interred legislation. Perhaps, too, a sentiment of natural equity enters into the prejudice, akin to the trades union view, that a man should have one trade and is entitled to make a living off it.

In America, however, we broke with the past, not only in political things, but also in industrial things. The large area over which trade is unhindered by national boundaries or by artificial barriers like octrois or by restrictions similar to guild control spoken of have permitted a freer development.

There has been an initial separation of the factory and the store. The factory has sought the localities best for its purpose—nearest the raw material and convenient to transportation. The work of distribution has been left to the energies of a distinct class. The conservative prejudice gendered by guild control of trade has been much fainter, with the result that development in merchandising has taken place upon lines more purely economic than in Europe. It has been a more rapid and unhindered evolution. The units have been fewer and larger, and greater efficiency and economy have resulted. The first stage of merchandising in America, as we have said, was represented by the general country store, possibly carried on in connection with other vocations—a very rudimentary and unspecialized type—the same man buys, sells and delivers goods, keeps accounts and advertises, if these latter features are present at all. Next a classification takes place in separate stores of distinct lines of goods, which represents a higher type involving a clearer separation of functions and a higher specialization. Perhaps there is a special buyer, and a special bookkeeper; certainly there is a delivery boy. Now, we can imagine this development proceeding along these lines indefinitely until it culminates in the big single line store of the metropolitan type, employing a multitude of buyers, accountants, sales people, floor walkers, inspectors, window dressers, cashiers, janitors, watchmen, cash girls, delivery men and an advertising expert or two. So far the evolution has been along distinct lines, actuated by a striving for greater economies obtainable through higher specialization.

An observer a few years ago might reasonably expect this growth to proceed indefinitely along these lines. But nature loathes monotony. She showers a myriad

of seeds, no two with exactly the same possibilities of life, upon a meager palm's breadth of soil, and by infinite repetition of the process starts a new species on its career, and thereby alters the face of a continent. So in purely human affairs the cost of an economical variation may be an immense initial waste.

In the rough classification of merchandise which I spoke of as growing out of the *mielee* of the country store, not every line was of equal mercantile importance. That is to say, in some lines a greater variety of articles and qualities and larger possibilities of aggregate business were involved. Especially was this true of the trade in women's apparel, the dry goods business so-called. In most localities at the time it detached itself from the country store it consisted of those articles which are the raw material of feminine dress, not including head wear or foot wear, together with some household utilities, such as bed clothing, table linen, curtains and carpets. These things in the average town constituted the stock in trade of the average dry goods store.

Now, women are *ex-officio* the purchasers for the family. On special occasions when unusually large or important purchases are to be made, the buying may come off with the advice, consent, and even the presence of the male, but in general, and it is only in general terms we can speak at all of such a matter, the woman does the bulk of the ordinary normal buying for the average American household. And it is equally true that a very large item of expenditures is the cost of feminine attire. Woman's dress is a matter of daily consideration. It consists of a multitude of details of the greatest variety and necessitates almost daily renewal and modification. Hence the average woman is a frequent visitor to the dry goods store, both on her own account, and that of the other feminine members of her family. Now, this fact gives the dry goods merchant a sort of strategic position in the struggle for business. His particular patrons, the women, are the largest and most frequent purchasers. They are familiar with the atmosphere of the dry goods store. The average man approaches these marts of trade with fear and trembling, but here the woman's "foot is on her native heath, and her name is McGregor." Naturally, if the goods be shown she drifts into the habit of making other purchases, buys things for her husband and the boys; buys her hats there, buys shoes there, buys bric-à-brac there, and, I am sorry to say, sometimes buys jewelry there. So, by a sort of natural accretion, the stock of the dry goods man becomes more varied. In the beginning his line possesses the advantages mentioned; it is large and varied and staple; it attracts the greatest number of buyers, and, as a natural evolution, it tends to absorb other lines. The dimensions of the dry goods business are normally very great, possibly greater than those of any other mercantile line. Ordinarily the condition of his business compels the dry goods merchant to employ a relatively large number of salesmen and saleswomen. So there is a chance to effect a higher specialization, an employe for this particular work, another

for that, and so on—hence greater efficiency. From the nature of the business relatively large space is required, so there is the opportunity for better economy. These advantages are inherent in the business, and have helped to give this branch of trade the commanding position it enjoys.

There are, it is true, inherent disadvantages in the conduct of a large business. The directing mind must be of a broader type. The difficulty of securing competent subordinates is considerable. The small merchant can have his business all under his eye, and will be apt to bring to every feature of it a greater degree of devotion and skill than the subordinate whose interest ends with his salary. This fact has acted as a check on the growth of the general store, as has also the instinctive prejudice of the community in favor of the one line store—a prejudice shared to a large degree by many of those merchants who could reasonably hope to see their own business undergo such an extension. There is very naturally in every business the temptation to take on lines which are apparently handled with profit by others. And there has always been a tentative reaching out after the profits that come from the successful handling of added lines. This very naturally arises, as I have tried to show in the dry goods trade. Certainly there are small dry goods stores, and unsuccessful ones, but in general the dry goods trade is made up of larger individual units. We can only speak in general terms in this matter, and with much qualification. But I think we are safe in saying, that the majority of department stores were originally dry goods businesses; that the gravitation of bulk and the attraction of economic handling have drawn the trade in other lines to themselves. The term "natural evolution" which I have used in characterizing the rise of the department store, is, I think, more applicable in this connection than in the case of so-called trusts; for in the progress of the latter, there is a stage that can hardly be called natural; namely, the creation of an artificial entity called a corporation. I do not know of an analogy in biological evolution to this feature of industrial concentration in the field of manufacture. The plan of incorporation with its manifest advantages over individual or firm activity would seem an indispensable stage in the growth of trusts. But in the case of the department store this growth has taken place as rapidly and surely in the case of individual or firm control as in the case of corporate control.

But there are certain phases of modern mercantile concentration to which I hesitate to apply the term evolution. In a large sense the term evolution describes the process by which things have changed from what they were to what they are, and in general this process has been a growth in the direction of greater definiteness, complexity and variety. When, however, the change in one of these particulars is reversed and the current runs the other way, that phenomenon, while a part of the general process, is given the special name of reversion. To illustrate: There is a disposition on the part of many public men to insist on the evolutionary nature

of the so-called trusts, and, no doubt, from the purely economic point of view, there are certain obvious economies possible for this form of organization which would be effected and entitle trusts to be called a natural evolution. But if, while securing these economies, they result in a lower standard of living, in longer hours, in less intelligent and skilled labor, in higher absolute values, in less certain employment, then so far as they do this they are not evolutionary, but reversionary. They revert in these particulars to conditions that have been outgrown. It is too soon yet to pronounce upon this matter. The future must determine whether trusts are entitled to shelter themselves behind this impregnable defense; for variation may, and often is, on one side an evolution and on the other a reversion. There has been all along a growing ethical, social, altruistic element in the progress of industrial development, so we are entitled to scrutinize the phenomena of each industrial variation to see to what extent it is characterized by these qualities. If we find them present to a less degree than in the type which preceded it, then in spite of any and all economies it may effect, it is not an evolution, but a reversion.

(To be continued.)

L. Dinelly, Terrell, Tex., has given a realty mortgage for \$1,000.

W. A. Wright, jeweler, Waterville, Kan., is reported to have purchased the entire stock of jewelry of G. S. Calhoun, Shawnee, Okla.

**The Latest Patents.**

ISSUE OF NOV. 21, 1899.

637,233. COLLAR OR CUFF BUTTON. JAMES B. CAVERS, New York, N. Y. Filed



May 19, 1899. Serial No. 717,391. (No model.)

A button composed of a shoe, a head and a telescopic shank, the shank consisting of two sections one arranged to slide within the other, and one section being provided at its open end with an annular inwardly projecting flange, and the other section being pivoted to the head and provided at one end with a shoulder and at the other end with a shoulder on the side opposite to the first-named shoulder, and a spring located between the two sections and adapted to subserve the double function of preventing one section being too far withdrawn from the other section and to exert its energy to force the shoulder of one section into engagement with the shoulder of the other section and hold the button in a contracted position.

637,315. TIME STAMP. JOHN C. WILSON, Boston, Mass. Filed April 16, 1894. Serial No. 507,626. (No model.)

637,366. ALARM WATCH. HENRY BAETHIG,

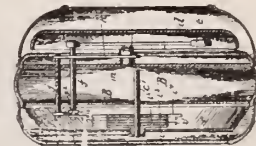

Buffalo, N. Y. Filed July 11, 1898. Serial No. 655,608. (No model.)

**"By Using Our Goods Your Goods Will Sell."**

**We Always Lead**

With Something New and Artistic for Manufacturing Jewelers.

**OUR FINDINGS SPEAK FOR THEMSELVES**

Call or Send for Samples of

**OUR LATEST**

**And Keep Your Trade Guessing What You Will Show Them Next.**

We are now showing a handsome and complete line of

**MEDALLIONS AND EBONY MOUNTS.**

**HEIMBERGER & LIND,**

158 PINE ST., METCALF BUILDING, PROVIDENCE, R. I.

The combination with the spindle operated by the watch movement, a series of trip wheels mounted side by side on said spindle and having different numbers of teeth, and the alarm device, of a rock shaft carrying the hammer and arranged parallel with said spindle, an actuating pawl capable of sliding lengthwise on said hammer rock shaft but held against turning thereon, a shifting arm capable of movement parallel with said rock shaft, and a rod connecting said arm with said pawl and arranged parallel with said rock shaft, whereby the movement of said shifting arm is transmitted to the actuating pawl and the latter is shifted on the hammer rock shaft to face either of said trip wheels.

**637,367. NOTE DISK MUSIC BOX.** GUSTAV A. BRACHHAUSEN, Rahway, N. J., assignor to the Regina Music Box Co., same place. Filed April 1, 1897. Serial No. 630,240. (No model.)

**637,368. GOVERNOR.** GUSTAV A. BRACHHAUSEN, Rahway, N. J., assignor to the Regina Music Box Co., same place. Filed July 18, 1899. Serial No. 724,221. (No model.)

**637,387. PROGRAM ALARM CLOCK.** JOHN L. HALL, Brookville, Pa. Filed Aug. 17, 1897. Serial No. 648,535. (No model.)

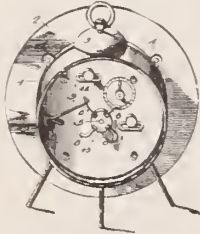

The combination with a clock, of a recording attachment consisting of a band encircling the casing and having outwardly extending ears, an annular plate fitted against the clock face to expose the dial and having its inner peripheral edge portion overlapping said band and clock casing, and having facial spaces corresponding with the divisions of the clock dial for inscribing memo-

randa thereon, and means for securing the memorandum plate to the supporting hand.

**637,439. FOUNTAIN PEN.** FERDINAND R. WOLTER, Kasson, Minn. Filed Nov. 28, 1898. Serial No. 697,720. (No model.)



In a fountain pen, the combination of an ink fountain *R*, and pen nozzle *L*, a feed bar *K*, provided at the upper side with a channel *x*, said channel *x*, constructed to have centrally located therein, and throughout its entire length, a V-shaped projection or ridge, whereby V-shaped grooves are formed on either side of the ridge, and the upper edge of said ridge *a*, standing below the upper edge of the walls of the channel *x*.

**637,444. BIFOCAL LENS.** JOHN L. BORSCH, Philadelphia, Pa. Filed March 18, 1899. Serial No. 709,571. (No model.)



A bifocal lens formed of two pieces of glass of dissimilar index and size placed and secured face to face, the smaller of said lenses being mounted in a recess in the larger of said lenses, and exposed upon one face of the latter.

**637,631. FOUNTAIN PEN.** BYRON F. MARSH, Eustis, Fla. Filed June 15, 1899. Serial No. 720,665. (No model.)

A fountain pen having a barrel, a pen seat fitted into the open end thereof and comprising a plug hermetically engaging the inner walls of the barrel, and an outer portion projecting beyond the barrel, the pen seat being formed with a longitudinal cavity extending through it from end to end, and an air tube fitting in the cavity and projecting beyond each end of the pen seat, the air

tube filling the inner portion of the cavity in the pen seat and being firmly engaged with the inner walls of the plug of the pen seat, and the outer portion of the cavity being enlarged at its outer portion to form an ink reservoir and the air tube

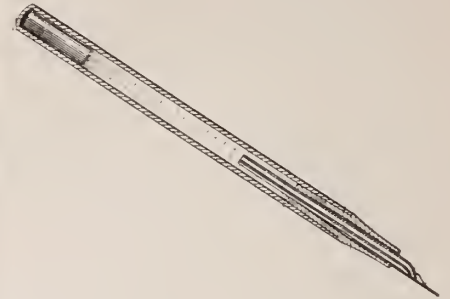

being formed with a longitudinally extending external groove forming an ink duct, the outer portion of the air tube serving to hold the pen point against the inner wall of the outer portion of the pen seat.

**637,454. ELECTRIC CLOCK.** FRED I. GETTY, Chicago, Ill., assignor to the Automatic Electric Clock Co., Kansas City, Mo. Filed Sept. 26, 1898. Serial No. 691,886. (No model.)

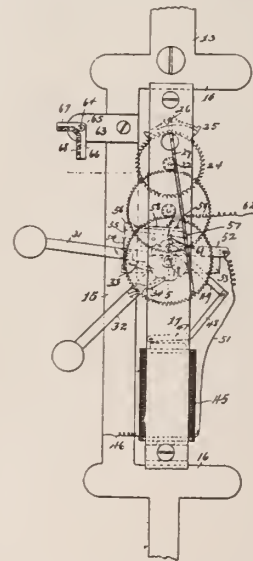

**637,721. TIME STAMPING MACHINE.** GEORGE E. EMERSON, Newark, N. J., assignor to the Emerson Time Stamp Co., same place. Filed Nov. 11, 1898. Serial No. 696,159. (No model.)

**EXPIRED PATENTS.**

[Recently expired patents of interest to the jewelry trade. Reported specially for THE JEWELERS' CIRCULAR by R. W. Bishop, Patent Attorney, 728 Fifth St., N. E., Washington, D. C., who will furnish complete copies of patents at the rate of 10 cents each.]

*Issued Nov. 28, 1882.*

**268,016. OPTOMETER.** F. A. HARDY, Chicago, Ill.

**268,102. ORNAMENTAL CHAIN.** J. J. HORTON, Attleboro, Mass.

**268,112. OPERA GLASS HOLDER.** WILLIAM MACK, Terre Haute, Ind.

**268,272 and 268,273. MUSIC BOXES.** ERNEST PAILLARD, Sainte Croix, Switzerland, assignor to M. J. Paillard & Co., New York, N. Y.

**268,322. SYNCHRONIZING CLOCKS.** LEONARD WALDO, New Haven, Conn.

**268,340. MACHINE FOR ROUGHING OUT PINIONS, ARBORS AND STAFFS FOR WATCHES.** C. V. WOERD, Waltham, Mass.

**268,354. DUST-PROOF WATCH PLATE.** ABRAHAM BITNER, Lancaster, Pa.

**268,355. LEAD OR CRAYON HOLDER.** C. W. BOMAN, New York, N. Y., assignor to Joseph Reckendorfer, same place.

*Design issued May 26, 1896, for 3 1-2 years.*  
**25,544. BADGE.** L. A. BROWN, St. Louis, Mo.

**MATHEWS & PRIOR,**

DESIGNERS AND MAKERS OF

**Sterling Silverware**

TO THE LEGITIMATE

**JEWELRY TRADE ONLY,**



245-247 West 28th Street,  
New York City.



**Eliassof Bros. & Co.,**

IMPORTERS AND JOBBERS OF

**DIAMONDS, WATCHES, JEWELRY,**

9-11-13 Maiden Lane,

Materials, Tools and Optical Goods.

NEW YORK.

ALBANY OFFICE: 62 & 64 STATE STREET.

**ALOIS KOHN & CO.,** SOLID GOLD CHAINS,  
4 MAIDEN LANE, Near Broadway, N. Y.

We call the attention of the Trade throughout the country to our line of

**LORNETTE AND GUARD CHAINS.**

Will send Samples on Memorandum on receipt of satisfactory reference. Correspondence Solicited.



# OPTICAL DEPARTMENT.

Note.—From this week till further notice this department will be run as usual, viz.: every other week.

## Encyclopedia-Dictionary and

## Reference Handbook of the Ophthalmic Sciences.

Copyrighted 1898, by The Jewelers' Circular Pub. Co.

BY R. H. KNOWLES, M.D.

[Commenced in issue of July 6, 1898.—Continued from  
page 49, Nov. 15, 1899.]

### PART XL.

**Lens** (*lens*). [Latin and German, *lentil* = a pea.] A transparent substance, crown glass or pebble chiefly, through which an object is increased or decreased in size. Lenses were employed at an early period in a form similar to a large reading or magnifying glass held in the hand. Rudyard Kipling discovered such a lens made of beryl in the ruins of Ninevah and this would indicate that lenses in this form were employed as early as the seventh century. The form of both convex and concave were double till 1804, when Wollaston invented the meniscus or periscopic lens which avoids chromatic as well as spherical aberration. He took the cornea as a hint. Cylinders were developed in 1865 after Donders had published his researches and the correction of astigmatism by means of cylindrical or astigmatic lenses. The Astigmatic Lenses of Stokes are employed for the purpose of demonstrating astigmatism and consist of convex and concave cylinders. The Crystalline Lens is a jelly-like body, globular in youth. It is surrounded by its capsule, the tendency of which is to flatten the lens. This lens lies in the path of the visual line, immediately beneath the aqueous humor, is one-fifth of an inch in its axial diameter and one-third of an inch in the transverse diameter. The capsule is in turn surrounded by the muscle of accommodation or ciliary body, held to its place by means of the suspensory ligament, the Zone of Zinn. These collectively give us the focusing apparatus. The Crystalline Lens has a focal strength of ten to twelve dioptries convex spheres during a state of rest (Static-refraction), and sixteen to eighteen dioptries convex spheres while in the state of its greatest activity (Dynamic-refraction). A Spherical Lens is a segment of a sphere and focuses in all meridians alike, while a Cylindrical Lens is a section of a cylinder and focuses in only one meridian. These lenses are found in the trial case and they are collectively spoken of as the Test Set of Lenses. Compound Lenses may be made up of a spherical lens upon one surface and a cylinder upon the other surface; such a lens is called a Sphero-Cylindrical lens or a Sphero-Cylinder.

**Lenticulous** (*len-tic-o'-nus*). [Latin and German, *lentil* = a pea + Latin, *conus* = apex.] A peculiar congenital malformation of the crystalline lens, producing an irregular astigmatism in which there is a conical

projection of the crystalline lens either anteriorly or posteriorly.

**Lenticular Astigmatism** (*len-tic-u-lar-as-tig'-mat-ism*). [Latin and German, *lentil* = a pea + *ula* = small + Greek, *a* = lacking + *stigma* = a point.] That variety of irregular astigmatism due to a misshapen crystalline lens. Irregular or Lenticular Astigmatism is divided under two headings:

Lenticular Astigmatism. { 1. Static.  
2. Dynamic.

1. Static Lenticular Astigmatism describes the condition of an eye having a misshapen crystalline lens while in the state of rest or during the period in which the rays of light from twenty feet or infinity, traveling in as nearly parallel paths as possible, will pass through and form an irregular image upon the retina. The skiascope will reveal very irregular lines while tilting the mirror, the lines either narrowing or widening near the center.

2. Dynamic Lenticular Astigmatism applies to an irregular image formed upon the retina after the rays have passed through a misshapen crystalline lens during the time the lens is rendered as convex as it is possible to be, or, in other words, during the period of reading, sewing, etc., etc. The two varieties mark degrees rather than kind. In either instance there is no lens which will correct the defect.

**Lentitis** (*len-ti'-tis*). [Latin and German, *lentil* = a pea + Greek, *itis* = an inflammation.] A suppurative state in which it is possible for the crystalline lens to become inflamed. Synonym: **Phakitis**.

**Leprophthalmia** (*lep-roph-thal'-mi-a*). [Greek, *lepis* = a scale + *ophthalmos* = eye.] A disease in leprosy manifesting symptoms, tubercular, nodular or papular, with characteristic inflammations of the superficial structures of the eyes.

**Lencitis** (*leu-ci'-tis*). [Greek, *leukos* = white + *itis* = an inflammation.] An inflammation of the sclerotic coat of the eye. Synonyms: **Scleritis**; **Scleroticitis**.

**Leukoma** (*leu-ko'-ma*). [Greek, *leukos* = white.] An opaque condition of the cornea in which this body resembles ground glass. The result of phlyctenular ulcers in which are appearances such as slaked lime produces when thrown into the eyes. This condition may be partial or complete. Partial Leukoma resembles a small patch upon the cornea; when it is very small it is a nebula. Complete Leukoma involves the whole cornea and it is then called Total Leukoma or Leucoma.

**Leukomatosis** (*leu-ko-mat-o'-sis*). [Greek, *leukoma* = albumen + *nosos* = a disease.] An unusual state of the cornea in which there is an increase of albuminous elements.

**Leukophthalmous** (*leu-koph-thal'-mous*). [Greek, *leukos* = white + *ophthalmos* = an eye.] A state in which the eyes are exceedingly white.

**Leukops** (*leu'-kops*). [Greek, *leukos* = white + *ops* = an eye.] A person whose eyes are very white.

**Leukoscope** (*leu'-ko-scope*). [Greek, *leukos* = white + *skopeo* = I see.] An instrument employed in making an examination of the eyes for color-blindness.

**Leukosis** (*leu-ko'-sis*). [Greek, *leukos* = white.] The progress of disease of the cornea from ulceration to opacity of the same, producing the condition of leukoma.

**Levator palpebra superioris muscle** (*le-va'-tor pal'-pe-'ra su-pe-ri-o'-ris mus'-cle*). [Latin, *levator* = an elevator + *palpebra* = an eyelid + *superus* = the leader, the highest.] This muscle has its origin at the lesser wing of the spheroid bone and insertion at the upper tarsal cartilage. It is for the purpose of lifting the upper eyelid. The third pair of nerves, the motor oculi, control the movements of this muscle, a paralysis of which or a thickening of the eyelids, producing ptosis or falling of the lids.

**Levorotatory** (*le-vo-ro'-tat-o-ry*). [Latin, *laevus* = the left + *rotare* = to rotate.] A crystal which turns polarized light toward the left.

**Lid** (*lid*). [Middle English, *lid* = lid.] A short term sometimes employed in place of Eyelid. The covering of the eye composed of skin and integument, the orbicularis palpebrarum and levator palpebra superioris muscle, the connective tissue, the palpebral cartilage and conjunctiva with the eyelashes and meibomian glands; all of which serve as a protection, for lubrication and for support.

**Lieberkühn, J. N.** Born 1711; died in Berlin, Germany, 1765. A celebrated physician and surgeon after whom the Fibres of Lieberkühn, the circular fibres of the muscle of accommodation, are named. He made a solar-microscope.

(To be continued.)

### A Binocular Microscope.

**U**NTER den Blinden ist der Einäugige König! (German proverb:—"The one-eyed man is a king among the blind.") This may be a truism for the blind, but is a poor consolation for the one-eyed person. For, through the loss of one eye the human strength of vision is not only decreased one-half, but the faculty of seeing objects plastically, i. e., in relief, which depends upon the convergence of both eyes, is lost as well. Would one believe, therefore, that the members of many professions voluntarily forego the use of one eye? For all persons such as watchmakers, opticians, engravers, miniature painters, zoologists, anatomists, etc., etc., who have to deal with especially small articles, the suppression of the vision of one eye at the expense of the other has been a necessity. The compulsion to use the microscope deprives them of the immense advantage of viewing objects in relief and—owing to the unequal employment of their organs of sight—injures their eyesight greatly.

These men will hail with delight the news that the famous oculist, Dr. Emil

Berger, residing at Paris, has succeeded in constructing a microscope for both eyes, which is said to obviate the defects of the old monocular medium in an ingenious manner and increases the strength of vision of both eyes in an equal degree, while at the same time enhancing the plasticity of the viewed objects. The employment of the old microscopes for both eyes is mainly opposed by the fact that they only have short focal distances of 5, 7½ and 10 cm., and the lines of vision of both eyes cannot be combined upon an object at so slight a distance. A binocular vision at so short a distance is physically impossible, because the inner canthi cannot turn the axes of the eyes far enough toward the center line. The binocular microscope of Dr. Berger brings the plastic image of the object into a normal distance from the eye (about 33 cm.). This invention, doubtless, represents an epoch-making novelty in the optical field, and solves a problem with which humanity has been confronted for more than two centuries, says *Technische Notizen*. The use of the microscope in the shape of stereoscopic spectacles constitutes for the members of the above-named professions an invaluable advantage, for the strengthening of the eyesight goes hand in hand with the obviation of the tiring and over-exertion of the eye muscles so well known to oculists.

T. D. Robertson, formerly with Jos. Linz & Bro., Dallas, Tex., has just commenced business on his own account with a new and complete stock at 314 Main St., same city.

#### New York State Opticians Hold an Interesting Session.

SYRACUSE, N. Y., Nov. 17.—The New York State Association of Opticians held their November meeting at the new rooms, 501 and 503 Dillaye building, on Wednesday, 4 o'clock P. M. The meeting was called to order by President Hamilton and the minutes of the previous meeting, read by Secretary Golder, were approved. Treasurer C. B. Hibbard, of Pulaski, made a report on the finances of the Association which was followed by a report of the standing committees. Messrs. Golder, of Seneca Falls, and Swart, of Auburn, reported on the details of the January meeting which will be held in Geneva. A large attendance is expected and there will be an all-day session, with lectures by prominent oculists and trips of inspection to the Geneva Optical Co.'s and Standard Optical Co.'s works, followed by a banquet in the evening. All opticians living in the vicinity are invited to attend.

There will be no meeting of the Association in December on account of the holidays; the January meeting will be held in Geneva, and the programme as arranged for the next three months follows: February—"Accommodation and Convergence," G. N. Luckey, of Baldwinsville; "Myopia," Frank Lee, of Memphis; "Astigmatism," Louis Emery, of Waverly. March—"Ophthalmoscope," Bert S. Hopkins, of Penn Yan; "Retinoscopy," F. L. Swart, of Auburn; "Ophthalmometer," A. W. Golder, of Seneca Falls. April—"Asthenopia," F. E. Robbins, of Elmira;

"Frame Adjusting," James Holden, of Syracuse.

The receipt of several communications asking for application blanks for membership was reported by the secretary. G. M. Babbitt, of Syracuse, then read an entertaining paper on "Hypermetropia." Mr. Babbitt discussed the form of the eye, its structure and powers, and then passed to the consideration of different styles of lenses. Mr. Babbitt, who is an ardent advocate of the double convex lens, said in part:

The glasses in most common use have their two surfaces ground of the same curve, convex or concave, on either side, and having their cones opposite each other are rendered free from chromatic substance and prismatic light, points of the utmost importance in the construction of spectacle lenses. Periscopic glasses in which the two surfaces are of different curvature are sometimes worn and claimed as giving rather more range of vision without turning the head, but their optical qualities are in other respects less perfect than those of the usual form and should be avoided. As the crystalline lens gradually increases in hardness as age advances, so that the ciliary muscles can no longer effect the change of form in the lens which is requisite for the concentration of divergent rays, it is evident that a suitable convex glass, which lessens the divergence of the rays before they enter the eye and thus calls for less effort of accommodation, must be the only means of relief. Glasses having their cones opposite each other and of uniform density, ground and polished, are the only kind to put before the eyes in spectacles. All others being bent or molded to the form are positively injurious and should be avoided.

Spirited discussion as to the respective merits of double convex and periscopic lenses followed the close of Mr. Babbitt's paper. Next on the programme was an able paper on "Dioptrics and Catoptrics," by president Fred Hamilton, of Syracuse. Mr. Hamilton entered into an elaborate explanation of the laws which govern refraction and then proceeded to the consideration of the various lenses and the process of making a lens of a certain focus and prisms of a certain degree. Mr. Hamilton said:

For my part I think it would be better for all concerned if we would drop the combination that we call periscopic and double convex and concave, and in their place use plano-convex and plano-concave sphericals. It would be possible then for us to carry plain spherical segments that could be used on either plus or minus sphericals or plus or minus cylinders. We could get a great many more combinations with less stock and at less than half the expense. To me the plano-spherical lenses are the ideal lenses.

After a few remarks on the refraction of the eye and reflection, Mr. Hamilton closed a paper which was made the more interesting and instructive by the use of numerous drawings and illustrations which he had prepared. The meeting then adjourned until the third Wednesday in January at Geneva.

A neat little clock in the window of A. B. Shaw, jeweler, New Rochelle, N. Y., has attracted much attention the past week. A tiny porcelain doll swings on a projecting bar, and her gentle see-saw marks the flight of time.

**JUNK-SHOP METHODS.** The time is not far distant when a jeweler will demand different methods than are now employed by some salesmen in disposing of their stock. How any jeweler with any reputation will allow an auctioneer to run in a lot of inferior goods and sell them on his reputation, using his store for a junk-shop to dispose of the auctioneer's goods, not his, is a hard problem to solve.

**E. J. GREGORY, Jewelers' Auctioneer,**  
Jewelers' Building, Boston, Mass.

## SUSSFELD, LORSCH & CO.



Ask your jobber for  
our lines of Optical  
Goods.

### Reading Glasses

in

**Pearl and Gilt**

as well as with

**Black Handles**

AND NICKEL MOUNTED.

### Opera Glasses

in latest styles.

37 & 39 MAIDEN LANE,  
NEW YORK.

**Workshop Notes.**

**Cold Soldering for Iron.**—Crush a n d mix six parts of sulphur, six parts of white lead and one part of borax. Make a rather thick cement of this powder by triturating it with sulphuric acid. The paste is spread on the surfaces to be welded, and the articles pressed firmly together. In six or seven days the soldering is so strong that the two pieces cannot be separated, even by striking them with a hammer.

**Steel Blue and Old Silver on Brass.**—For the former dissolve 100 grammes of carbonic carbonate in 750 grammes of ammonia and dilute this solution with distilled water, whereupon the cleaned articles are dipped into the liquid by means of a brass wire. After two to three minutes take them out, rinse them off in clean water and dry in sawdust. Old silver on brass is produced as follows: The articles are first silvered and next painted with a thin paste, consisting of graphite six parts, pulverized hematite one part and turpentine, using a soft brush, and dry well. The powder is then brushed off thoroughly. Oxidized silver is obtained by dipping the silvered goods into a heated solution of liver of sulphur five grammes, ammonia carbonate 10 grammes, and water one liter. Only substantially silvered objects are suited for oxidation, as a weak silvering is taken off by this solution. Unsatisfactory coloring is removed with potassium cyanide solution. Furthermore, it is recommended to lay the articles in hydrogen sulphide-ammonia solution diluted with water, wherein they acquire a blue to a deep black shade.

**Jos. Linz & Bro.'s Fine New Building and Store.**

**T**HE Dallas (Tex.) *Morning News* of Nov. 5 devoted one and one-half columns of its space to the fine, fireproof building of Jos. Linz & Bro., jewelers, corner of Main and Martin Sts., that city. The building is six stories high, topped by a roof garden. It occupied two years to design and complete the structure. The building with its appointments is a triumph of architectural ingenuity. The jewelry establishment of Jos. Linz & Bro., on the ground floor, is a grand, harmonious composition of polished, figured mahogany, marble, polished plate glass and mirrors with most artistic and effective trimmings in delicate shades of green, pink and gold, softened by massive paneled ceiling supported upon Ionic columns of polished green scagliola marble with antique bronze caps of perfect proportions. The whole effect is illuminated by some 1,700 electric lights under ground glass globes. The wholesale department of Jos. Linz & Bro. is in a separate room, flanked by numerous massive burglar-proof safes, large vaults, etc. Over the wholesale department, in the mezzanine story, from which the entire floor can be overlooked, is the executive department and the book-keepers, etc., isolated from all other departments.

Jacob Dover, Nelson, B. C., is making extensive alterations to his jewelry establishment.



**“GESSOART”** A HARDENED COMPOSITION RESEMBLING TERRA COTTA.  
**DISPLAY FIGURE.**

18 Inches High.

DECORATIONS IN APPROPRIATE COLORS.

This unique, attractive and useful article, used in the show window for special display of all manner of articles; or can be sold as a card receiver.

PRICE, BOXED, \$2.50; NET CASH WITH ORDER.

**L. W. LEVY & CO.,** Novelties and Optical Goods,

194 BROADWAY, NEW YORK.

Successors to Levy, Dreyfus & Co.

**CHATELAINÉ BAGS.** PATENT FRAME.



STERLING MOUNTED POCKET-BOOKS, CARD CASES, Etc.

**All Fashionable Leathers**

SPECIAL HOLIDAY LINES.



**C. F. RUMPP & SONS,**

FINE LEATHER GOODS,

Fifth and Cherry Streets, - Philadelphia.

New York Salesroom: 621 Broadway.

**Our Hand-made Cases**

are constructed in the old reliable way, which is a pride to the Manufacturer, Dealer and Wearer.

STAMPED.



ALL CASES BEARING THIS MARK, ARE HAND-MADE.

STAMPED.



Manufactured by

**DUBOIS WATCH CASE CO.,**

Makers of

**SOLID GOLD CASES.**

21 and 23 Maiden Lane, New York.

**EBONY GOODS.**

Before placing your orders for import do not fail to see our line. We can save you money. A postal card will insure a call from our representative with samples.

**SELWYN IMPORTING & TRADING CO.,**

14 East 17th Street, New York.

# BRADLEY & HUBBARD MFG. CO.

Have produced for this season's trade the finest line of goods ever offered.

## Art Metal Goods,

PITCHERS, VASES, CANDELABRAS, FIGURES, BUSTS, TABLES, ETC.....

## Reception Lamps

WITH THE CELEBRATED "B. & H." and B. & H. RADIANT BURNERS. NEW AND ORIGINAL DESIGNS. HANDSOME AND EXCLUSIVE FINISHES.

*Dealers are cordially invited to inspect the line of Samples at our SALESROOMS.*

NEW YORK: 26 Park Place to 21 Barclay Street.

BOSTON: 160 Congress Street.

CHICAGO: 131 Wabash Avenue.

PHILADELPHIA: 714 Betz Building.

FACTORIES and OFFICES: MERIDEN, CONN.

## SILVER NOVELTIES

### SIMMONS & PAYE,

"The Souvenir House,"

129 Eddy St., Providence, R. I., will mail to any jeweler on request a copy of their latest catalogue, illustrating manicure goods, toilet goods, and silver-mounted glass goods.

## CROUCH & FITZGERALD,

Jewelry Trunks and Cases, 161

Broadway, Bet. Cortland and Liberty Sts.

688 B'way, 723 6th Av. NEW YORK.

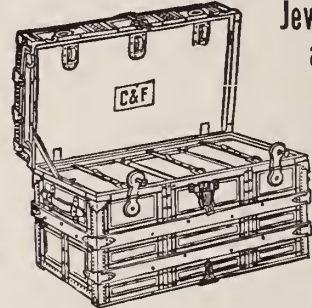

## PAIRPOINT MFG. CO.

New Bedford, Mass.

### LATEST CONCEPTIONS

... IN ...

Rich Cut Glass,

Silver Plate

.. AND ..

Table Ware.



38 Murray St., New York City.

Temple Building, Montreal.

## MAINE ANNOUNCEMENT.

### DR. KNOWLES

will continue giving private instructions in

## Optometry

during the month of November in Portland, Me. For terms and important particulars write to

R. H. KNOWLES, M. D.,

480 CONGRESS STREET,

ROOM 3, PORTLAND, ME.



H. M. RICH & CO.,  
Jewelry - Auctioneers,  
7 and 9 Franklin St.,  
BOSTON, MASS.

WOOD & HUGHES,  
Sterling Silverware Manufacturers,  
FINE PLATED WARE,  
No. 24 John Street, - New York.

THE BASSETT JEWELRY CO.,  
Fine Gold-Filled Chains,  
Lockets and Gold Jewelry,  
PROVIDENCE, R. I.

Established 1879.

Manufacturer of

## LOUIS W. HRABA, Fine Leather Goods

29 East 19th St., New York.

Exclusively for the Jewelry Trade.



### SAMPLE OF ENGRAVING DONE ON THE Eaton-Engle Engraving Machine.

CATALOGUE AND SAMPLE OF WORK FREE.

EATON & GLOVER have removed to the FULTON BUILDING, 87 NASSAU ST., Cor. Fulton, N. Y.

BUY "SIMMONS" CHAINS THEY SELL!  
RE SIMMONS & CO. ATTLEBORO, MASS. N.Y. 9-13 MAIDEN LANE.



## THE RAMBLER'S NOTES.

WHAT THE RAMBLER SAW AND HEARD AMONG THE DEALERS IN ART POTTERY, CUT GLASS, BRONZES, ETC.

**NEW PATTERN IN GILT CLOCKS.**

TO their series of new gilt clocks, already mentioned in this column, the F. Kroeber Clock Co., 360 Broadway, New York, recently added a style known as "Paris No. 4." This style is perhaps the "Frenchiest" in effect of all thus far introduced in this line. Unlike its predecessors, it has no glass panels, the panel space being filled in with decorated porcelain, and a porcelain ornament also appearing at the top. Both in style and price this clock may be considered one of the most desirable novelties of this kind put before the jeweler this season.

**L. STRAUS & SONS' CUT GLASS.**

THE assortment of cut glass shown every year by L. Straus & Sons, 42-48 Warren St., New York, for the holiday trade, is always large, and this season's display in no way departs from the general rule. One of the most interesting features in the exhibit of this firm's glass ware is the unusually extensive assortment of very large punch bowls. The bowls referred to range from 12 to 20 inches in diameter, and include shallow and deep varieties, as well as those with large central glass feet. Among these bowls are a great number mounted with rich bands of sterling silver in bright and oxidized finishes, while on some of the pieces in colored glass are to be found silver mountings with gilt finish.

**FINE DECORATED GLASS FOR THE HOLIDAYS.**

JEWELERS who have not yet completed their holiday stock of fine decorated glass ware should not fail to inspect the exhibit of these lines now made by Chas. Ahrenfeldt & Son, 52-54 Murray St., New York. The display now made in the firm's glass department is one of the finest they have yet shown to the trade, and includes not only all the usual lines of Bohemian colored and gilt glass ware, colored glass with cut and other decorations, etched glass filled with gilt and iridescent vases of many varieties, etc., but also a great number of lines with

odd and unusual decorations, as well as reproductions of old German glass, old Dutch effects and a number of novelties. Among the latter may be mentioned a new line in reproductions whose body is a green glass having thereon figure and other decorations done in brown and black in the style of etchings, together with inscriptions.

THE RAMBLER.

## The Results of Prosperity.

BY S. S. CONOVER.

THE year 1899, which is rapidly drawing to a close, has been most unique in its freedom from business failures. In the memory of the oldest merchants no year in mercantile life compares favorably with it. This is all the more remarkable, in view of the increased volume of business transacted, attended by substantial increases in prices. A canvass of some of the principal lines of trade indicates that the amount of losses sustained this year through bad debts is only trivial; and the credit man who had so much to contend with in the tempestuous periods of 1893 and 1896 has recently experienced the pleasure of the Summer sea.

The Bankruptcy law has also had the effect of checking questionable embarrassments on the part of the smaller traders, who were in the habit of failing over night. Everyone now knows that in case of business suspension the law gives all of the creditors an equal chance, and this acts as a deterrent to those who are in any way inclined in the direction of making fraudulent assignments. Another pleasing feature that has characterized the present year is the numerous credits entered to profit and loss accounts, previously charged with losses made in former years.

**Bronzing Cast Goods.**—Here are two very simple methods for bronzing castings. It suffices to cover them with a light layer of linsced oil and then heat over a coal fire, prolonging the heat until the desired shade is reached. Or else expose the objects to be bronzed for about five minutes to the vapors of a bath composed of 50 parts of nitric acid and 50 parts of concentrated hydrochloric acid. Then rub the articles with vaseline and heat until the vaseline is decomposed. The objects to be bronzed must always be perfectly polished.

## OLD BRITISH POTTERY MARKS

HOW TO IDENTIFY 17TH CENTURY AND 18TH CENTURY CHINA AND PORCELAIN.\*

[Commenced in issue of Nov. 15.]

**Chelsea Porcelain** (Founded in 1676; early specimens date from 1745).—The information about the earliest marks on Chelsea porcelain still remains uncertain. The triangle incised in the paste (Fig. 17) belongs to them, as a milk jug, in the possession of W. Russell, Esq., proves, which bears the above mark and the inscription "Chelsea, 1745." As another earlier mark must be considered the embossed oval with raised anchor upon it



FIG. 17.



FIG. 18.



FIG. 19.



FIG. 20.



FIG. 21.

(Fig. 18). Later the plain anchor was adopted. Its form varies, especially with regard to the angle and to the points of the transverse bars; sometimes the latter are barbed (Figs. 19 and 20), sometimes like annulets (Fig. 21). The cable ring on the top is hardly ever omitted. On pieces of the best quality the anchor mark is gilt, on specimens of the second quality painted in red, brown, or purple on the glaze. In rare cases two anchors with cable rings are employed. This anchor mark must not always be looked for on the bottom of the piece, but is frequently found on the pedestal, or on some other part of the decoration. By its minute size it often escapes observation, or, if in gold, gets rubbed off.

Further means for identifying Chelsea porcelain is afforded by the glaze, which is of a softer milky white and less thick than on Bow china. On cups and saucers, plates and dishes, the glaze sometimes accumulated around the basal rim in tears, but in most specimens the inequalities of the glaze are removed by the rim having been ground smooth. Three spots free from glaze, caused by the three points on which the piece rested during the firing, are frequently found on dishes and other flat pieces manufactured at Chelsea.

\*Adapted from the Pottery Gazette.

# THE LADY RACINE

IS THE

## Best Chatelaine Watch

10 Line,  
11 Line,  
12 Line,  
13 Line,  
Hunting or  
Open Face,



Nickel,  
Steel,  
Silver,  
Enameled,  
Gold,

In new and tasty designs.

Can be ordered from all Reliable Jobbers.

# The "Bryant" Rings.

ARE KNOWN TO THE JEWELER'S CUSTOMERS AS THEY ARE TO THE JEWELER, HAVING FOR 50 YEARS OCCUPIED THE PROUD POSITION OF "THE BEST."



THE "BRYANT" MARK IS ACKNOWLEDGED TO BE A GUARANTEE OF QUALITY, STYLE AND FINISH.

GOODS SENT ON APPROVAL TO RESPONSIBLE DEALERS.

Our new Fall line comprises a profusion of new designs.

**M. B. Bryant & Co.,**  
10 Maiden Lane, New York.

**WM. H. BALL & Co.,**

Our Specialty:

MANUFACTURING JEWELERS,

Anderson Building, 12-14-16 John St., N. Y.



Everything in  
**Gold Bracelets.**

Curb Bracelets, Bangle Bracelets, Fancy Stone Bracelets, Baby Esther Bracelets, Bracelet Mountings.

**Derby Porcelain** (1751).—The marks on Derby china changed with the four periods. Before 1769 the mark, if any, was a simple D, or the word "Derby," printed in red or scratched in the clay. After the union of the Chelsea and Derby works the anchor of Chelsea crossing a

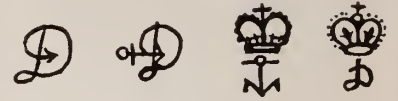

FIG. 22. FIG. 23. FIG. 24. FIG. 25.

capital D (Fig. 22, 23), was adopted. After the visit of the King and Queen in 1737 the crown first appears above an anchor (Fig. 24), or over a capital D (Fig. 25), generally in blue, rarely in puce or gold. The second Duesbury (circa 1788) separated the D from the crown by crossed batons, with three dots in each side angle (Fig. 26), in gold, blue, or puce, later in



FIG. 26. FIG. 27. FIG. 28.

vermillion. Sometimes batons and dots are wanting, and the word "Derby" or a capital D placed underneath the crown (Figs. 27 and 28). The monogram D.K. (Duesbury and Kean) occurs occasionally after 1795 (Fig. 29). Specimens so marked are scarce, and therefore valuable. Three Chinese marks, called the potter's stool (Fig. 30, a, b, c), are ascribed to the Derby Factory, and on some pieces the crossed



FIG. 29. FIG. 30. FIG. 31.

swords of the Meissen fabric (Fig. 31), or the Sèvres mark surmounted by a crown (Fig. 32) are found. A star with six points stamped in the bottom center of the piece may likewise be considered a Crown Derby mark. Bloor continued to mark his ware with the crown, the batons and dots less carefully drawn, the crown not jeweled, as in the third Duesbury's time (Fig. 33), until 1825, when he substituted his own name in connection with a crown. The successors of Bloor, Messrs. Locker



FIG. 32. FIG. 33. FIG. 34.

& Co. (1849), Stevenson, Sharp & Co., and Courtray, Bloor's agent in London, marked their wares with their names in full. Fig. 34.—Stephenson & Hancock, King-street Factory, 1862; same mark used afterwards by Sampson Hancock, and now in use.

(To be continued.)



# Stella Music Boxes

ARE UNEQUALED FOR

Sweetness, Harmony and Volume of tone, and have smooth metallic tune sheets playing thousands of tunes.

**Why Not** handle a line of Music Boxes the sale of which you can control and **Make Money?**

WRITE FOR CATALOGUE AND TERMS.

**Jacot & Son,** 39 UNION SQUARE, NEW YORK.

**W. C. A. WESTPHAL,**  
WATCHMAKER,  
41 Maiden Lane, NEW YORK.  
Established 1892. Telephone, 3684 Cortlandt.  
Estimates, Repairing, Adjusting of Chronometers, all Complicated Watches and Fine Time Pieces.  
**DEMAGNETIZING.**  
Watches made Non-Magnetic.  
Fine Wheel and Pinion Cutting

American  
Watch Case Co.,

**A.W.C.CO**

9-11-13 Maiden Lane,  
Gill Building, New York.

**FERD. FUCHS & BROS.,**  
**SILVERSMITHS,**  
MAKERS OF STERLING SILVERWARE,  
34 East 29th St., - New York.



144 PINE ST., PROVIDENCE, R. I.

Plated Seamless Wire  
and Aluminum Solder.



**ESSER & BARRY,** Largest Manufacturers of Cheap and Medium Priced IMITATION DIAMOND JEWELRY IN AMERICA.

Write us for samples of almost anything with an Imitation Diamond in it.  
MAIN OFFICE AND FACTORY, 101 SABIN ST., PROVIDENCE, R. I.



GOLD SHELL.

"Buy direct from the manufacturer and get all that is coming to you."  
SEND FOR OUR "HOT CATALOGUE, CONTAINING COLD FACTS AND PRETTY PICTURES."  
**CLARK & COOMBS,**

86 WEST EXCHANGE ST., - PROVIDENCE, R. I.

WE ARE HEADQUARTERS FOR.....

Gold Shell Rings...

**AIKIN, LAMBERT & CO.,**  
MANUFACTURERS OF  
FINE GOLD PENS, HOLDERS, PENCILS,  
TOOTH PICKS and NOVELTIES.

PAUL E. WIRT FOUNTAIN PENS, at new and lower prices . . .  
MERCANTILE FOUNTAIN PENS, guaranteed to give satisfaction.  
Catalogues with terms and discounts furnished to the trade.  
BRANCH, 103 STATE STREET, - - - CHICAGO.

19 MAIDEN LANE, NEW YORK.

**AIKIN-LAMBERT JEWELRY CO.,**  
IMPORTERS OF  
**DIAMONDS.**

JOBBER IN  
WATCHES, JEWELRY, CHAINS,  
NOVELTIES, ETC.

LATEST DESIGNS. LOWEST PRICES.

# CHAS. F. WOOD & CO., DIAMONDS

1 MAIDEN LANE, NEW YORK.

IMPORTERS AND CUTTERS.

## DIAMONDS.

LARGE ASSORTMENTS.

DESIRABLE SIZES.

ATTRACTIVE PRICES.

**R., L. & M. FRIEDLANDER,**

30 MAIDEN LANE, N. Y.

97 HATTON GARDEN, LONDON.

## HALL CLOCKS,

*Mantel Clocks,  
Traveling  
Clocks,  
Clock Sets,  
Regulators,  
Bronzes,  
Vases, Ivory  
Miniatures  
and Art Goods.*



Fall Line Now Ready.

**Harris & Harrington,**

32 and 34 VESEY ST., NEW YORK.

Sole Agents to the Trade for J. J. Elliott & Co., London.

## HOROLOGICAL DEPARTMENT,

BRADLEY POLYTECHNIC INSTITUTE,

PEORIA, ILLINOIS.

Largest and best watch school in America. We teach Watch Work, Jewelry, Engraving, Clock Work, Optics. (Formerly Parsons' Horological Institute.) Catalogue Free.



## 37 YEARS OF HONEST RETURNS

IS OUR GUARANTEE OF SATISFACTION TO ALL OUR CUSTOMERS.

WE DO OUR OWN SMELTING,

**JOHN AUSTIN & SON,**

ASSAYERS, REFINERS AND SMELTERS,  
74 & 76 Clifford St., Providence, R.I.

## CUT GLASS

**Whiskey Bottles,  
Brandy Bottles,  
Clarets, Decanters,  
with and without  
Silver Mounts.**

ABSOLUTELY NEW  
GOODS PARTICULARLY  
ADAPTED FOR MEN.

**LE BOUTILLIER & CO.**

18 East 17th St., New York.



GOLD AND SILVER PENCILS,  
PENHOLDERS, &c.



**FAIRCHILD & JOHNSON CO.**

Office and Factory,  
220 FOURTH AVENUE, N. Y.

## Satisfaction

AND....

## Promptness

is the secret of our success. Our chief aim has always been to render prompt returns and to give satisfaction to all our customers.

**CONLEY & STRAIGHT,**

GOLD AND SILVER  
REFINERS, ASSAYERS and  
SMELTERS,

236 Eddy Street, PROVIDENCE, R. I.

## Horseshoe, Clover, Heart, Wishbone and Anchor.

THESE ARE A FEW OF THE THOUSAND DIFFERENT DESIGNS OF LUCKY BANGLES.

**S. & B. LEDERER CO.**

FACTORY: 100 STEWART STREET,  
PROVIDENCE, R. I.

New York Office, 11 John Street.

Chicago Office, 131 Wabash Avenue.

## EMPIRE COMBS. SIDE COMBS.

GOLD AND JEWELLED ORNAMENTED.

SPECIALTIES IN ROMAN WORK.

**DAY, CLARK & Co.,**

MAKERS OF FINE JEWELRY,

23 MAIDEN LANE, N. Y.

**PROV. STOCK CO. Chains**

HIGH GRADE ROLLED PLATE

BRACELETS, LORGNETTES.

**10K. GOLD**

Scarf Pins, Brooches,  
Neck Chains, Lorgnettes,  
Bracelets.

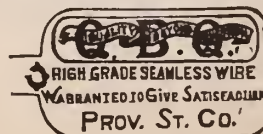

400 Stewart St., PROV., R. I. 11 John St., N. Y. Silverm. Bldg., CHICAGO.

IMPORTERS AND CUTTERS OF DIAMONDS  
**Arnstein Bros. & Co.**  
 65 Nassau St. NEW YORK.  
 Cor. John.

**DIAMONDS** Importers and Cutters.  
**L. & M. KAHN & CO.,**  
 172 Broadway,  
 Cor. Maiden Lane, N. Y.



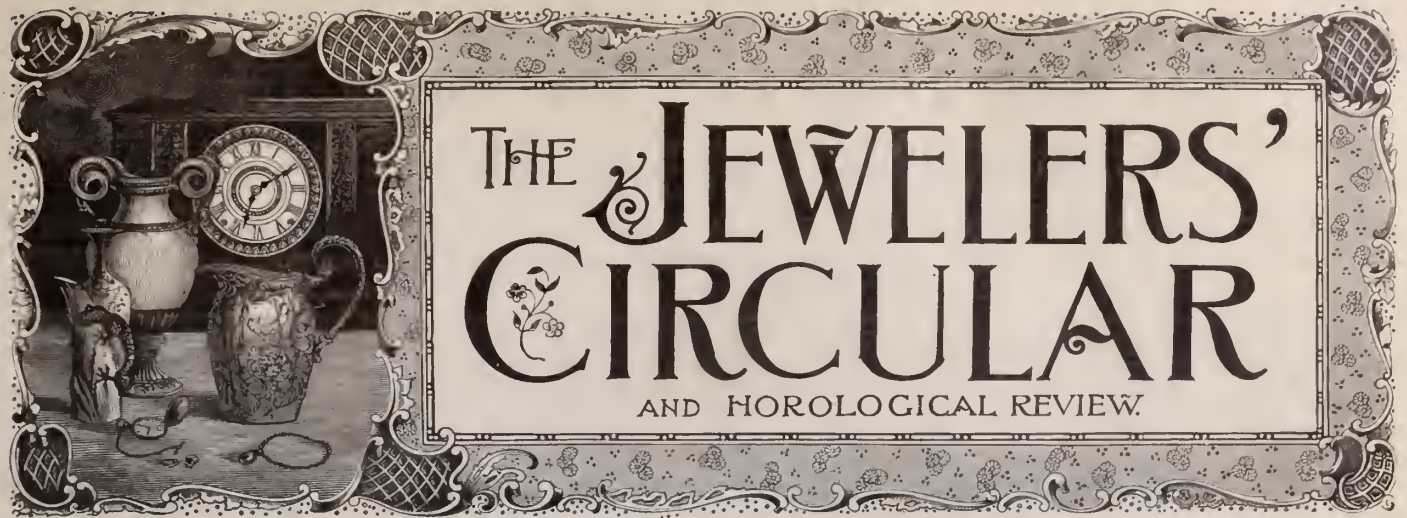

Corbin Building, 11 John St., Corner Broadway, New York.

Copyrighted by THE JEWELERS' CIRCULAR PUB. Co.

Entered at the Post Office in N. Y. as second-class matter.

VOL. XXXIX.

NEW YORK, WEDNESDAY, DECEMBER 6, 1899.

No. 19.

UNIQUE DESIGNING IN AMERICAN GOLDSMITHING.

THE Board of Trade, of Columbus, O., has sent one of the most novel invitations to Admiral Dewey to visit that city that has ever been gotten up. It is made of solid 14-karat gold and the metal in it weighs almost one pound. In size the tablet is 4½ by 6½ inches. The main part of the plate is taken up with a map of the Buckeye State on which the body of the invitation is engraved. In the center of this is an engraving of the State House, and the whole is surrounded with a border of raised work. At each of the upper corners of this is a medallion, the one on the left being a representation of Columbus, and the one on the right that of Dewey himself. At the lower left hand corner appears a representation of the ship, *Santa Maria*, and at the right hand Dewey's flagship, *Olympia*. These are all surrounded with wreaths of green gold in raised work. The whole is surmounted with the seal of the State of Ohio, and from beneath it protrudes an Admiral's flag and the Stars and Stripes. Just beneath the seal appear the words "Columbus to Dewey." At the bottom are a number of emblems of naval warfare, including a ship's anchor. Between this and

the invitation proper are the names of the Governor, the Mayor of the city and the

members of the City Council. The tablet was designed and made by D. L. Auld, manufacturing jeweler, Columbus, and is a handsome piece of work. A committee of prominent citizens of the city were in Washington Nov. 20 and presented the invitation to the Admiral, Hon. J. H. Outhwaite acting as spokesman.

Beatrix first mentions casually what I consider the most novel fashion of the hour, but, oh! so expensive to carry out, says a writer in the *Ladies' Home Journal*. She says: "All the best dressed women here wear them now." She was talking of sets of buttons to be worn on gloves. They come, it seems, in sets of three and four or more, and are made of real stones, turquoises, pearls, emeralds, rubies, garnets, etc., set in gold, and may be sewed on any pair of gloves one wishes. They have a loop at the back just like an ordinary button. The common pearl button is taken off and the jeweled one put in its place.

A fascinating Parisian fancy in the new girdles is one composed of five rows of sparkling cut crystal beads fastened with graceful golden clasps.

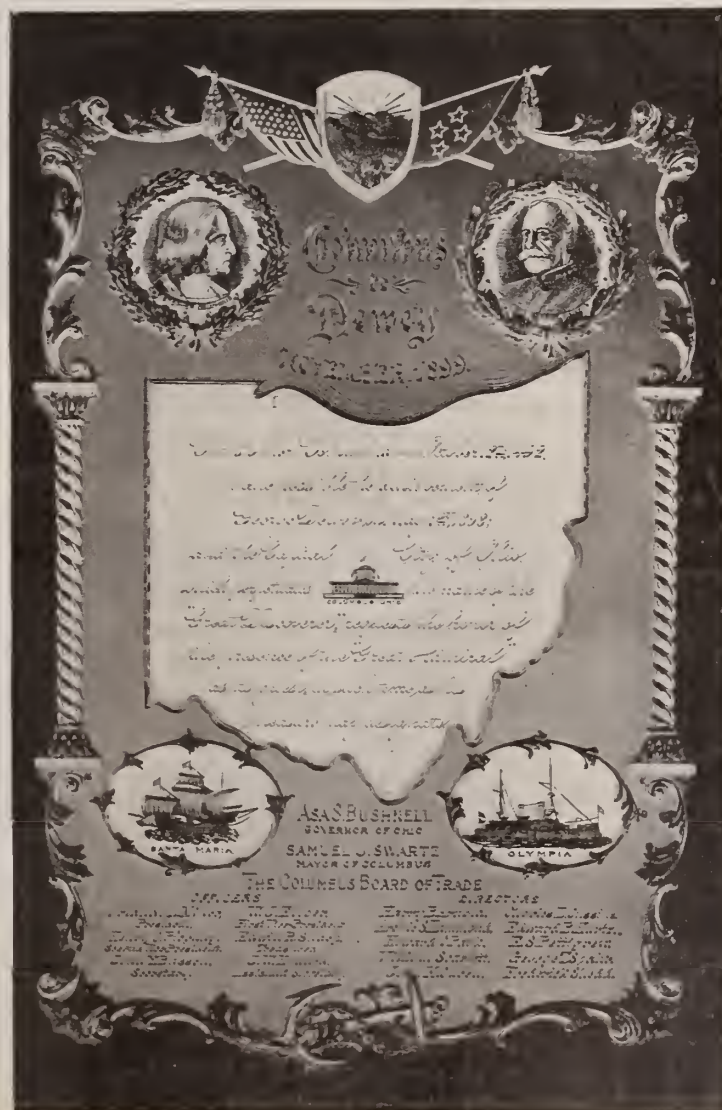

GOLD INVITATION FROM THE CITY OF COLUMBUS, O., TO ADMIRAL DEWEY.

# Our New Lines For The Spring Trade

will be ready right after Christmas, and as we are sparing no effort or expense to bring them to perfection they will be lines not surpassed by any on the market during the season. The quality will be up to our usual high standard of rolled-gold plate, while the finish is the finest that can be produced.

LOCKETS, CHARMS, BRACELETS, CHAINS, PINS, EARRINGS, SILK VEST CHAINS and HAIR CHAIN MOUNTINGS; also a large variety of those dainty little BROOCHES now in vogue, and an enlarged line of BUCKLES.



Do not allow your stock of STERLING SILVER TOILET and MANICURE GOODS and NOVELTIES to get too low, as you will have a good demand for them all through the Holiday Season.

OUR CATALOGUE IS YOURS FOR THE ASKING.

**THEODORE W. FOSTER & BRO. CO.,** 100 RICHMOND ST., PROVIDENCE, R. I.  
Successors to FOSTER & BAILEY.



## A USEFUL NOVELTY

### Bottle Openers,

in Sterling Silver and Silver Plate. The convenience and cleanliness of this form of bottling having brought it into general use, these Openers will be appreciated for the table. Send for catalogue.

MADE BY

**Goodnow & Jenks,**  
SILVERSMITHS,  
Stanhope and Morgan Sts.,  
Boston,

who have obtained the SOLE RIGHT from patentees to manufacture this article.



# Seasonable Goods, Real Values.

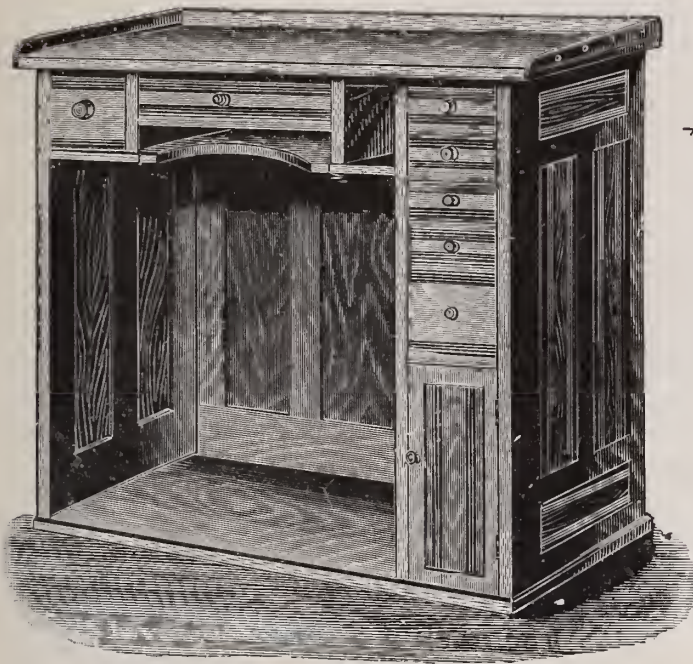

No. 1.

**SOLID OAK, PLAIN TOP, WATCHMAKERS' WORK BENCHES**, without castors, made of well-seasoned Oak lumber and put together by people who know how.

**1st QUALITY, \$9.00 NET.**

**2d " 8.00 " SOLID OAK.**

Size: Length, 40 in.  
Height, 40 "  
Width, 20 "

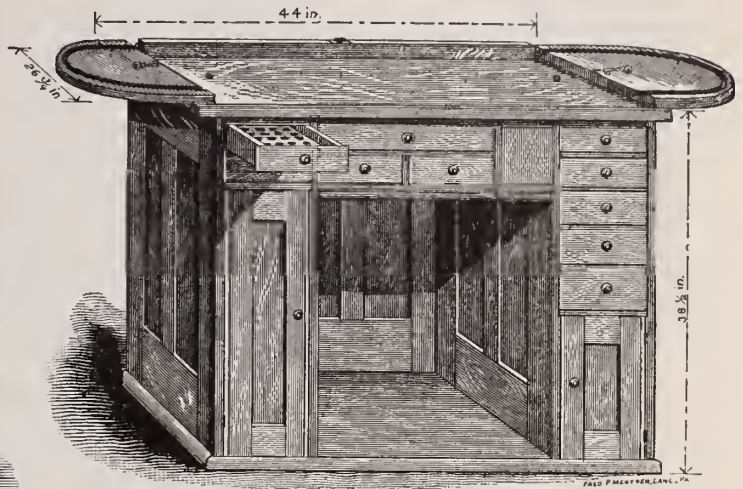

No. 2.

**OUR ROLL-TOP SOLID OAK BENCHES** are made of the same material as the plain tops, have curtain tops, 10 drawers, apron, chalk hole, lock automatically and are on castors.

**PRICE, \$14.00, NET CASH.**

Size: Length, 44 in.  
Height, 40 "  
Width, 26 3/4 in.

## Double-End and Single-End Gravers and Liners.

Our GRAVERS have been imitated, in part, as to style only. The quality of our gravers stands the use better than any other graver made to-day.

If your jobber does not have them, insist on getting them, and take no other, or send to us, where your wants will be filled with dispatch.

# L. C. REISNER & CO.

Manufacturing Jobbers, Importers and Exporters,  
Watch Materials, Tools and Supplies,

Jewelry Repairers for the Trade.

LANCASTER, PA.



Bonbon Dish,  
No. 2142.

*"Sterling Silver Goods Only."*

This is only one of our new  
**BONBON DISHES**



TRADE-MARK.

**FRANK M. WHITING  
& CO.,**

**Silversmiths,**

**NORTH ATTLEBORO, MASS.**

1128 Broadway, New York.

220 Sutter St., San Francisco.

Complete line of Samples always on display  
at our New York Office.

Our line of Dishes, Trays, Bowls,  
Tea Sets, Loving Cups, Toilet  
Goods, etc., is very complete  
this season.

# Of Greatest Importance

to the live manufacturing Jeweler is a careful  
consideration of our lines of Jewelers' Findings.

NEW ASSORTMENTS OF

**Buckles, Galleries, Brooches,  
Settings, Pins, Etc.**

**THOS. W. LIND,**

MANUFACTURER OF JEWELERS' FINDINGS,

67 FRIENDSHIP STREET,

PROVIDENCE, R. I.

# Enameled Watches

Iridescent and dull finish

New England Watch Co.  
Waterbury,  
Conn.



## “Elf”

—10 Ligne.

ALL ENAMEL,  
IRIDESCENT:

Blue, No. 8803  
Red, 8805  
Green, 8807

INLAID ENAMEL BACK,  
IRIDESCENT:

Blue, No. 8483  
Red, 8485  
Green, 8487

DULL ENAMEL:

Chrysanthemum Pattern.

White, No. 8661  
L't Blue, 8663  
Green, 8665

Rococo Pattern.

White, No. 8621  
L't Blue, 8623  
Green, 8625

## “Cavour”

—15 Ligne.

INLAID ENAMEL BACK:

Blue, No. 9653  
Red, 9663  
Green, 9667

The numbers above given call for blue watches—the price list will show the numbers of other colors.

## CHARMING - STUNNING - BEAUTIFUL:

the gleam of the iridescence and the dainty gold florets underlying the enamel produce an effect that is simply exquisite. Our *Enameled Watches* are in all the best colors to match, or harmonize with, the most delicate shades of dress goods. The *Iridescent Enamels* are in dark red, blue, and green (with like colored dials, if desired), and the *Dull Enamels* in light blue, light green, and white, with rich cream dials, figures of either gold or blue, and delicately patterned gold hands.

The enameling is all on Sterling Silver, which gives precisely the same effect as if it were on solid gold, and at a great saving in cost.

*Brooches* may be had to match the watches in designs and colors; attractive boxes add to their effectiveness as holiday packages.

Our last year's enamels were the first to be sold out, and although we have a splendid stock of these new styles for this season, we do not expect the line to last very long.

Decide upon what you want, then *order at once* and *save disappointment*.

THE NEW ENGLAND WATCH COMPANY,  
WATERBURY, CONN.

# ALMOND DISHES SOMETHING FOR YOUR HOLIDAY TRADE

THESE DISHES ARE OF GOOD  
WEIGHT AND THE PRICES  
AT WHICH WE ARE SELLING  
THEM PERMIT OF THEIR  
BEING USED AS LEADERS  
BON · BON · DISH  
TO MATCH... WRITE  
FOR PRICES

ILLUSTRATIONS  
FULL SIZE



No. 257.



No. 258.



No. 1000.

**R. WALLACE**  
**& SONS MFG. CO.**  
SILVERSMITHS  
WALLINGFORD · CT.  
BRANCHES  
226 · 5<sup>TH</sup> · AVE · NEW · YORK  
109 · WABASH · AVE · CHICAGO  
120 · SUTTER · ST · SAN · FRANCISCO

**FALL and HOLIDAY FASHIONS.**

**A LADY'S RAMBLES AMONG THE JEWELERS.**

The noble red man and his customs furnish the *motif* for an exceedingly unique and thoroughly American line of holiday silver wares. These articles are finished with a curiously indented surface enameled in reds, greens, blues, etc., reminiscent of the native ideas of color but softened and subdued from any crudity. Here, there and everywhere, dotted around with a view solely to good effect, are precious stones—spinel, olivines, rhodolites, colored pearls, brilliants, etc. For men, match boxes, cigarette cases, cigar cutters, knives, etc., exploit the new idea. On the larger pieces are depicted figures and woodland scenes—an Indian in full panoply of the chase or war, deer coursing through the forest, a graceful canoe and its occupants, and the like.

Curiously enough the most characteristic feature of the new North American silver manifests itself for the benefit of the feminine contingent of buyers, and this is neither more nor less than the "scalp-lock," which, in the form of finest silver wire, figures upon a number of personal ornaments. For instance, little plaques of silver enameled and jeweled as already described, punctuate long neck chains at regular intervals, and from each of these plaques hangs a lock of fine silver wire representing the historic and sanguinary emblem of savage prowess. This miniature and conventionalized scalp-lock also furnishes the pendant for many pins and brooches in odd and effective original designs. Particularly happy results are achieved with this Indian enameling and jewelery in serpent bracelets and bangles. Smelling bottles furnish another article in which the boldness and freedom of aborig-

inal art has been cleverly adapted to present standards. A further ingenious and admirable notion is the introduction of polished arrow heads into the silver belt buckles. Small arrow heads also replace the more commonplace bead and cabochon ornaments of long silver chains to which they are attached as pendants.

Umbrellas, a standby of perplexed Christmas shoppers, are this season handsome and varied in the extreme. One of these, of which the handle and the ferrule fold back by means of a double hinge and screw arrangement, so that the umbrella fits easily into a dress suit case, represents a decidedly attractive novelty. The parts are not separated, therefore not liable to be lost, and when screwed in position for use the joints are firm and not noticeable.

Belt buckles grow larger; some conventional oval and square forms are seen, but odd and fanciful designs predominate. Some of the prettiest novelties are in French grey silver or in gold richly shaded.

Old Dutch designs are liked for chate-laine bag frames.

Small sized, open-face and half-hunting case watches in plain bright gold with white dials represent the stylish utilitarian watch for women.

The head (silver or silver gilt) of the latest hat pin is long and slender with a high, round topped stone set in it.

A baby's knife and fork shows just a dainty little flower edging.

An addition to table ware, which is sure of a welcome in every household, is the roast fork. This is a large, two tined fork,

supernumerary to the carving set, which is to be plunged into the middle of fowl or roast and there remain as a handle, thus obviating the troublesome and frequent withdrawal and replacement of the usual fork. The roast fork has a curved stag handle more or less decorated with silver.

Delightful bonbon and almond dishes come in deep sapphire or ruby glass set in old English pierced silver frames.

Pencil holders, paper weights, ink stands, stamp boxes, cutters and folders, blotters, pen wipers, racks for paper, envelopes and postal cards give scope to the various styles of silver decoration and loom up temptingly upon the horizon of holiday trifles.

Handsome dark woods predominate in walking sticks, with crooks either right angled or rounded. Sometimes the knobs of a stick are tipped with silver. Smooth, black handles are banded with silver. Massive handles are in heavily carved French grey silver and gold handles are also elaborately chased. Caps and knobs remain standard styles.

A grateful gift for a smoker is to be found in a small, red morocco case containing a silver gilt match box, knife and cigar cutter.

Nut bowls, an article appropriate to the season, come in silver and in silver mounted glass, both the low, wide bowls and the taller ones being in style.

There is perhaps hardly a prettier and more fashionable evening ornament than the single-strand pearl necklace with diamond clasp.

Turquoise tips the point of silver pen holders.

ELSIE BEE.

H £

We Manufacture  
 Knives, Forks, Spoons and Cutlery.  
 Hollow Ware, Toilet Ware and Manicure Pieces.  
 The Kind that is sought in Jewelry Stores  
 Not found elsewhere.  
**HOWARD STERLING CO.**  
 Silversmiths.  
 Providence - New York - San Francisco.

# "OMEGA" WATCHES.

NONE BETTER MADE. OVER 1,000,000 IN USE.



Pendant Set. 12, 14 and 16 Size.  
Made in Gun Metal, Silver, Gold-Filled  
and Solid Gold Cases.

Our 10 Ligne O. F. "Omegas," full Jeweled Anchor Movements, in 14 K., plain polished or enameled cases, are "just the thing" for the Holiday trade.

Our 12 Size "Omegas," made in 7 and 15 Jewel grades, and Our 16 Size "Omegas," made in 6 different grades—7 Jewels to 21 Jewels—are particularly desirable where fine timepieces are desired.

The "Omegas" are sold only to the regular trade, so no prices will be found in any publication whatever, thereby insuring a good profit.

**Send for Price-List.**

**Edmond E. Robert, 3 Maiden Lane, N. Y.;**  
**Cross & Beguelin, 17 Maiden Lane, N. Y.,**

**SOLE SELLING AGENTS.**

## Our Hand-made Cases

are constructed in the old reliable way, which is a pride to the Manufacturer, Dealer and Wearer.

STAMPED.



ALL CASES BEARING THIS MARK,  
ARE HAND-MADE.

STAMPED.



Manufactured by

**DUBOIS WATCH CASE CO.,**

Makers of **SOLID GOLD CASES.**

21 and 23 Maiden Lane, New York.

## SILVER NOVELTIES

### SIMMONS & PAYE,

"The Souvenir House,"

129 Eddy St., Providence, R. I.,  
will mail to any jeweler on request a  
copy of their latest catalogue, illus-  
trating manicure goods, toilet goods,  
and silver-mounted glass goods.

DON'T FORGET THE JEWELERS' CIRCULAR PUBLISHING CO.'S BOOK LIST when in want of any technical work in the Jewelry or Kindred Trades.

# Mossberg & Granville Mfg. Co.,

PROVIDENCE, R. I.

## HEADQUARTERS FOR JEWELERS' AND SILVERSMITHS' MACHINERY.

GRINDING AND POLISHING JEWELERS' ROLLS A SPECIALTY.

N. Y. Office, 26 LIBERTY STREET.

Exhibition at the Philadelphia Bourse.

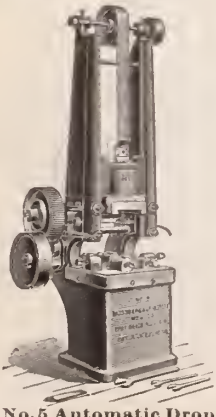

No. 5 Automatic Drop.

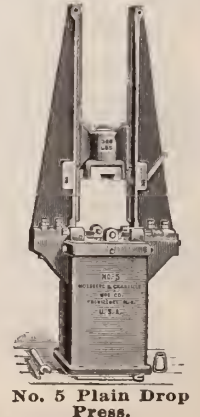

No. 5 Plain Drop Press.



**WATCH CASE GUARANTEES.**

**THE RETAIL JEWELERS SPEAK OUT AND GIVE THEIR IDEAS ON AN IMPORTANT MATTER BEARING UPON THEIR TRADE.**

[This series of letters began in issue of Nov. 15.]

It was upon the request of several responsible jewelers that THE CIRCULAR entered upon the undertaking of obtaining a consensus of opinion from the retail trade regarding the guaranteeing of gold filled watch cases, and sent to a large number of jewelers, indiscriminately, a letter of which the following is a copy:

NEW YORK, Sept. 8, 1899.

WE ARE SENDING THIS LETTER TO THE RETAIL TRADE WITH THE OBJECT OF GETTING THEIR VIEWS ON AN IMPORTANT SUBJECT, NAMELY: THE GUARANTEEING OF FILLED WATCH CASES. FROM THE RESPONSES RECEIVED MAY BE EVOLVED SOME VALUABLE SUGGESTIONS.

OF THE FOLLOWING FORMS OF GUARANTEE, WHICH DO YOU CONSIDER MOST JUST, AND WHAT ARE YOUR ARGUMENTS ON THE SUBJECT?

1. SHOULD THE MANUFACTURER GIVE A NEW CASE OF THE SAME GUARANTEE IN EXCHANGE FOR THE OLD CASE THAT HAS NOT LIVED UP TO ITS GUARANTEE?

2. SHOULD THE MANUFACTURER EXCHANGE THE CASE THAT HAS NOT LIVED UP TO ITS GUARANTEE WITH ONE OF LOWER GUARANTEE? THAT IS, IF A 20-YEAR CASE HAS BECOME DEFECTIVE AT THE END OF 10 YEARS, SHOULD IT BE REPLACED WITH A 10-YEAR CASE?

3. SHOULD THE MANUFACTURER REPAIR THE CASE AND PUT IT IN CONDITION TO OUTLIVE THE UNEXPIRED TERM, IF THE CASE SHOWS THE BASE METAL BEFORE THE LIFE OF THE GUARANTEE HAS EXPIRED?

4. SHOULD HE GIVE A NEW CASE AND CHARGE FOR THE LENGTH OF TIME THE CASE THAT DID NOT LIVE UP TO ITS GUARANTEE HAS BEEN WORN; IN OTHER WORDS, REBATE FOR THE UNEXPIRED TERM OF GUARANTEE?

YOURS VERY TRULY,

THE JEWELERS' CIRCULAR PUB. CO.

All those jewelers who did not receive this letter are cordially invited to send their views upon this subject, replying to the questions seriatim or collectively. Their replies will receive the same measure of considera-

tion as those received direct from the letters themselves. The more views on this subject expressed by the trade at large the more convincing will be the conclusions reached.

[Fourth series of replies.]

COLUMBUS, O., Nov. 12, 1899.

Editor of THE JEWELERS' CIRCULAR:

Yours of the 8th inst. to hand, contents noted. In regard to manufacturers of filled gold watch cases I claim the manufacturer should stand by his guarantee; otherwise the retail merchant has no show at all. We, the retail merchants, make seven-tenths of our sales on the strength of the guarantee. Yours,

P. C. KROUSE & CO.

GENESEO, Ill., Sept. 12, 1899.

Editor of THE JEWELERS' CIRCULAR:

In reply to yours of the 8th would say: Question 1. No. 2. Manufacturers should not be asked to do more than give 20 years' wear. 3. Should repair the case if practicable to last out the 20 years, or give one that would. 4. No. It would create too much muddle. Yours,

FRED STEIN.

AURORA, Ill., Sept. 12, 1899.

Editor of THE JEWELERS' CIRCULAR:

Why is not the guarantee of a filled case to the dealer the same as a guaranteed main spring to the customer for a certain length of time? If a mainspring that we furnish breaks at end of nine months, the party wants a new one and would laugh at us if we charged him with nine months' service of old one. I claim if they guarantee the case for a certain length of time the manufacturers should replace it with one equally as good. Yours, &c.,

W. W. DENNEY.

CUYAHOGA FALLS, O., Sept. 12, 1899.

Editor of THE JEWELERS' CIRCULAR:

1. He should give a legitimate dealer a new case even if it has worn 15 years. But if case had changed hands or been sent in by another dealer I suggest manufacturer ignore it.

2. No.

3. No. Send new case. See above.

4. No.

This gold filled case business has got to a point where it places the manufacturer in the same boat as a business man doing business with not enough capital, and knowing every day that his expenses are greater than his income.

Twenty years ago I paid \$18 to \$22 each and not one of the cases that I ever paid over \$15 for has ever worn off, and I think I voice the feeling of most dealers that if that same grade case was made to-day we would sell more cases and make more money. In the last eight years I have not given a personal guarantee on any make of filled cases, and I openly discourage the sale, and urge the sale of solid cases. There is a day of reckoning near at hand to all case manufacturers who have extended their warrants. But as I said in my answer to your first question, if they insist on giving such contracts make them stand by that agreement, and I for one shall insist on their doing it. But only in cases where I sell to a good customer and the watch does not change hands, i. e., is brought back by the original purchaser, I shall insist on the maker keeping that customer in a "covered" case, or one that does not show base metal for the term of the warrant. But I will not return case not sold by me to the maker. Yours respectfully,

B. F. PHILLIPS.

NASHUA, N. H., Sept. 12, 1899.

Editor of THE JEWELERS' CIRCULAR:

It is with pleasure that I reply to your communication received this morning in regard to filled case guarantees, for I feel that this is one of the most important questions that the retailer has had brought before him for many years; and while I have listened to arguments in favor of nearly all the forms presented by you, I must say that I can see only one position that any man who claims to be honest and just in business transactions can accept, and that is Form 1. Why? For 20 years I have been selling the popular gold filled cases to my customers, giving them a certain guarantee from the maker that said case is good for a stated period of time, and by my actions, at least, endorsing the guarantee as good; therefore, if I am an honest man, I am under obligation to stand by the guarantee as given by myself and as understood by my

**THE APOLLO** 

WARRANTS THE EPITHET "POPULAR,"

as shown by sales from Maine to Oregon.

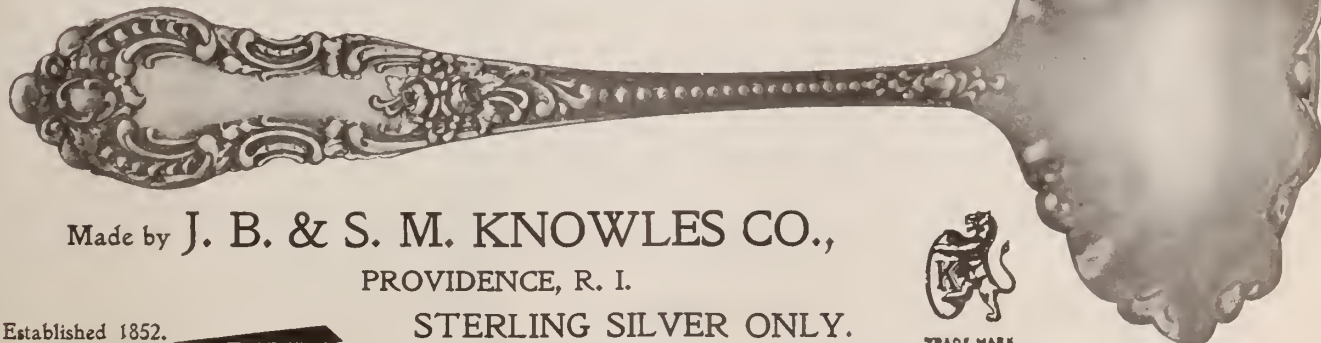

Made by **J. B. & S. M. KNOWLES CO.,**  
PROVIDENCE, R. I.

Established 1852.

**STERLING SILVER ONLY.**



customer; and if the case does not prove as represented I am expected to replace it with one that will stand the test of the guarantee. And it gives me pleasure right here to say that I have found all the leading filled case manufacturers except one ready and willing to send a duplicate (new) case in place of every one that has proved defective, and in nearly all cases they have written me a letter of thanks for calling their attention to the case, and have requested me to do so again should I have an occasion to do so. Now, gentlemen, the position the above case makers have taken with me is, as I believe right, and the only honorable position for anyone to take. It may not be pleasant to have the goods returned, but time, I believe, will prove that the company that goes back on its own guarantee, will be the loser in the end.

Of course, if the returned case should show an unreasonable lack of care on the part of the wearer and the defect due to his abuse, rather than to natural wear, both sides of the question should be considered in the spirit of right and justice to all concerned.

Thanking you for bringing this matter before the retail jewelers, and hoping that it will create such a spirit among the trade that they will demand from all case makers an honest and righteous guarantee that they will stand back of, and thus save many unkind feelings between them and the dealer and his patrons.

Very respectfully yours,  
E. E. CHENEY.

KEENE, N. H., Sept. 12, 1899.

Editor of THE JEWELERS' CIRCULAR:

Replying to yours of the 8th inst. will

say, when the public buy a watch case with a 20-year guarantee, they expect it to wear 20 years. I have just had a case come back that had been in wear 11 years; the party wanted it made good for 20 years from time of purchase; he was not willing to take a new case with a rebate for the unexpired term of guarantee.

I think the manufacturers should repair the case, and put it in condition to outlive the unexpired term, or if a 20-year case becomes defective at the end of 10 years or so, it should be replaced with a new 10-year case. I believe this is the most just for both parties.

I think it time some understanding was brought about so that the retail jeweler would know what to tell his customer when selling a gold filled watch case, for some think they can wear a case 15 years, then get a new 20-year case for the old one.

Yours very truly,  
S. S. QUINN.

MARSHALLTOWN, Ia., Sept. 12, 1899.

Editor of THE JEWELERS' CIRCULAR:

In answer to your circular of the 8th would say:

- No. 1. Yes.
- No. 2. No.
- No. 3. No. Should give a new one.
- No. 4. Should give a new case and not make any charges.

Respectfully,  
R. W. CHAMBERLAIN.

(Series of letters to be continued.)

A. H. Roberts, formerly of St. Paul, Kan., has again gone into the jewelry business, having opened a new stock in Erie, Kan., the firm name being Roberts & Stauffacher.

Importations at the Port of New York.

Weeks Ended Dec. 2, 1898, and Dec. 1, 1899

China, Glass and Earthen Ware:	1898.	1899.
China .....	\$23,509	\$62,871
Earthen ware .....	16,223	13,698
Glass ware .....	15,234	23,035
Instruments:		
Musical .....	17,436	11,518
Optical .....	9,969	9,634
Philosophical .....	524	2,964
Jewelry, etc.:		
Jewelry .....	5,389	5,481
Precious stones .....	95,619	207,912
Watches .....	19,689	33,211
Metals, etc.:		
Bronzes .....	541	1,434
Cutlery .....	22,178	40,163
Dutch metal .....	814	760
Platina .....	64,690	62,530
Silver ware .....	890	5,425
Miscellaneous:		
Alabaster ornaments .....	80	6
Amber .....	42	1,447
Beads .....	1,087	1,335
Clocks .....	6,062	4,874
Fans .....	4,998	4,288
Fancy goods .....	4,125	3,186
Ivory .....	15,976	44,140
Ivory, manufactures of.....	178	123
Marble, manufactures of.....	3,659	1,941
Statuary .....	724	11,185

The Extent of the West Texas Pearl Hunting Industry.

AUSTIN, Tex., Nov. 26.—The pearl industry in the Concho River, in west Texas, has grown very rapidly during the past few years. Many men are now employed in the work of hunting for pearls along that clear stream. In Sterling, Concho and Tom Green counties there are a number of organized companies who make a business of gathering and selling the pearls. These localities are in a very sparsely settled part of the State, and the nearest railroad point is many miles distant. It is for these reasons that the general public, even in Texas, are unaware of the extensiveness of this industry.

The pearls gathered along the Concho are marketed twice each year. The semi-annual harvest is intrusted to an expert. He takes them to New York city and obtains for them the highest market price. The great majority of the gems range in value from \$5 to \$35. Some valuable pearls have also been found in the Llano River and other tributaries of the Upper Colorado River.

The Bankruptcy Affairs of Elmer E. Starr.

TOLEDO, O., Nov. 28.—The case of Elmer E. Starr, jeweler, was taken up before Commissioner of Bankruptcy Belford, Nov. 25. The creditors appointed Lorain C. Miller as trustee. Between \$10,000 and \$12,000 of unsettled claims were shown up. The stock will be sold at private sale. The creditors will meet within the next two weeks to determine the time of the sale.

The contents of the safe of C. J. Duncan, Massillon, O., when taken from the fire ruins of the jewelry store were found all right. The knob on a wheel was broken off, but otherwise the safe was not seriously damaged. After a careful inventory of the stock saved Mr. Duncan finds his loss to be between \$2,000 and \$2,500.

WATCHES

WHO SAID WATCHES?

Ladies' Watches,  
Gentlemen's Watches,

Railroad Watches.

We Are the Largest Distributors of

Dueber-Hampden Watches

IN NEW YORK.



John N. Sherwood & Co.

Watches. Chains. Diamonds. Jewelry.

No. 3 MAIDEN LANE, NEW YORK.

# THE DUEBER HERALD

THE ADVOCATE OF HONEST BUSINESS METHODS.  
✻ DEVOTED TO THE RETAIL JEWELRY TRADE. ✻

Vol. I.

CANTON, OHIO, DECEMBER, 1899.

No. 9

## TRUTHS.

You may hide Truth;

\* \* \*

You may cover it, disguise it, deny it.

\* \* \*

You may down it for a time—but only for a time; for, do what you will, Truth will prevail in the end.

\* \* \*

The Dueber-Hampden Works are the largest and best-appointed watch works in the world. That is Truth.

\* \* \*

The Dueber-Hampden Watch is the most accurate and reliable in the world, "The Best." That is Truth.

\* \* \*

The success of the Dueber-Hampden Works, the success of the Dueber-Hampden Watch is unequalled. That is Truth.

\* \* \*

And Truth will prevail.

## LABOR AND MACHINERY.

To produce a perfect watch, perfect labor and perfect machinery are necessary

The attributes of the workmen must be skill, integrity and the ability to fill perfectly the positions assigned to them. The machinery must be modern, practicable and perfectly adapted to their requirements.

All this, the reader will say, is self evident. True; but how many watch factories are there who can boast of perfect labor and perfect machinery?

The management of the Dueber-Hampden Works have made a study of the labor and machinery questions, with the result that their skilled labor and their machinery represent the very best obtainable.

So far do they carry care and discrimination, that no help is hired without passing muster before John C. Dueber personally, the President of the Dueber-Hampden Works; no machinery is made or purchased, be it ever so trivial, without Mr. Dueber's sanction, and not one is there in the vast army of hands, from foreman to errand-boy, with whom Mr. Dueber is not personally acquainted

Therefore it is that the high order of talent employed by the Dueber-Hampden factories cannot be equaled by any or all of their competitors.

## CASE-TALK.

Over thirty-five years ago the first Dueber watch case was born.

\* \* \*

It triumphed. Then, with every new case, the triumph of Dueber goods grew more pronounced.

\* \* \*

Why? Because "What is worth doing, is worth doing well" is the motto under which Dueber goods are made.

\* \* \*

To-day, despite the tremendous growth of the enterprise, the same careful and rigid inspection is made of all Dueber goods, as when every case was passed upon by John C. Dueber himself.

\* \* \*

Dueber goods are: **Term and Stamp True.**

Alvarado, Texas.  
I am a chief dispatcher at this station for the M. K. & T. R. R., and am the possessor of one of your new 17-jewel watches named "New Railway." It gives perfect satisfaction and is one of the best timekeepers on the road.  
O. E. MAER.

Let Columbia time  
Her Progress by the  
Dueber-Hampden Watch.

DUEBER  
WATCH  
CASES  
make trade and  
hold it.

## "THE AMERICAN BEAUTY"



**Sterling and  
Essex Gold Filled.**

UNEQUALED.

PRICE, \$2.00. FOR SALE BY ALL JOBBERS.

**Hayden Mfg. Co.,**

**21-23 MAIDEN LANE,  
NEW YORK.**

### Death of Count Von Imhofft, Watchmaker.

ATLANTA, Ga., Nov. 25.—Emaciated by consumption, surrounded by his pictures, books, musical instruments, paraphernalia of his profession, with his sword and old revolver hanging near his pillow, and with only an old negro woman and a watchman of a building to watch it, the body of W. S. Langbein, or more properly, Count Von Imhofft, was added to the immortal list Friday night, in a room of the Chamberlain-Johnson-Dubose building. With not a living relative in this city, and but two or three friends, W. S. Langbein, a German watchmaker and jeweler, followed his profession in Atlanta almost unknown. In his younger days Langbein was in his own country proud, rich and surrounded by all that was wished for, and was called Count Von Imhofft.

He served with distinction in the Franco-Prussian war. Always a close student, he had grown to have opinions of his own and to hold to these with all the tenacity of his stern ancestors. When the time came for him to obey certain commands of his father which did not agree with his ideas in some way, he rose in his strength and refused so to do. The result was he was disinherited. An affair of the heart brought on a duel in the midst of all this. When the storm was passed the young count found that he must leave the country and face the future in a new country. He came to America and settled down to the life of a jeweler. Of an artistic, mechanical nature, he soon mastered the trade, and in

Atlanta he was pronounced one of the most efficient, careful and delicate workmen in the city. He had been here for the past 12 or 13 years, and was about 55 years old.

### Wallace P. Myers Files a Petition in Bankruptcy.

WORCESTER, Mass., Nov. 25.—Wallace P. Myers, jeweler and optician, Washington Ave., who formerly conducted an optician's room at 225 Main St., and came to Worcester from Derry, N. H., filed a petition in bankruptcy in the United States District Court, at Boston, Thursday. The claims were contracted while he was in business in Derry, N. H.

Myers' liabilities are \$1,075.40; assets \$250. The unsecured claims amount to \$975.40 and the secured to \$100. L. H. Pillsbury & Son, of West Derry, N. H., have a claim for \$50, which is secured, and the Travelers' Insurance Co., Hartford, Conn., have one for a like amount. The principal creditors holding unsecured claims and the amounts due them are: Echo Lodge, I. O. O. W., West Derry, N. H., \$104.15; G. O. Goodwin & Co., \$354.62, and Smith, Patterson & Co., \$163.16, both of Boston; Charles Bartlett, West Derry, N. H., \$58.50. The assets are made up by these items: Household belongings (except), \$100; jewelers' tools, \$100; debts due the petitioner, \$50.

Will Crandall has opened a jewelry business in Madelia, Minn.

George J. Consigny, Emmetsburg, Ia., has sold real estate for \$880.

## Exquisite Enamel Watches

FOR THE HOLIDAYS.

THE FINEST ASSORTMENT OF  
DAINTY GOLD AND SILVER EN-  
AMELED WATCHES, ARTISTI-  
CALLY DECORATED, FULL JEW-  
ELED LEVER AND CYLINDER  
ESCAPEMENTS.

Quality Warranted.

**HIPP. DIDISHEIM & BRO.,**

**54 MAIDEN LANE, NEW YORK.**

CHICAGO OFFICE, CHAMPLAIN BLDG.

**"Montana Diamond Co." Charged with Being a Larcenous Enterprise.**

BOSTON, Mass., Dec. 3.—Considerable stir has been created in town by the action of Judge Dewey in granting a warrant for the arrest of Isaac M. Jacobs, head of the Montana Diamond Co., so called, which has a store on the ground floor of the Jewelers building. This action was taken on Friday at the instigation of a Boston daily newspaper, complaints having come to the paper that the concern was doing business illegally and making misrepresentations to purchasers of its jewelry.

It is claimed that customers were informed that the "diamonds" were real stones, crystals dug out of the ground in Montana, whereas lapidaries in the Boston trade to whom they were submitted pronounced the "gems" paste. The specific charge against Jacobs under Massachusetts laws is larceny, and four counts are enumerated. He was not in Boston on Friday and the warrant was not served. It is reported that he is in Philadelphia. Two salesmen, Felix Wiener and Samuel Hirshfeld, also charged with larceny on account of alleged misrepresentation in selling goods, were arrested Saturday. A representative of the newspaper in question and two police inspectors made the purchases upon which the specified charges were based.

None of the jewelers in the big Jewelers building has liked the idea of having such a concern in the building with him, but several, when interviewed, said that

the proprietor, in their opinion, had a perfect right to sell imitation gems freely so long as the real character of the material was acknowledged. If, as had been alleged, there had been misrepresentation, they would be very glad to see the business shown up in its true light. Jacobs has been in business in New York and Philadelphia, as well as in Boston, and he came here early in February of this year, securing a lease of the store for one year. He has done an excellent business, apparently, requiring the services of about half a dozen employees.

**Jewelers' Gold Bars Withdrawn and Exchanged.**

*Week Ended Dec. 2, 1899.*

The U. S. Assay Office report:  
 Gold bars exchanged for gold coin.....\$184,931.02  
 Gold bars paid depositors..... 60,136.39

Total .....	\$245,067.41
Of this the gold bars exchanged for gold coin is reported by the Sub-Treasury as follows:	
Nov. 27 .....	\$31,384
Nov. 28 .....	47,329
Nov. 29 .....	39,138
Nov. 30 (Holiday).....	.....
Dec. 1 .....	5,299
Dec. 2 .....	21,164

Total .....

Otto Mueller, son of ex-mayor Gustave Mueller, of Wausau, Wis., has opened a jewelry store in that city.

A new jewelry store has been opened in the Byrne block, Littleton, N. H., by O. P. and F. F. Giles, of Fryeburg, Me.

OTTO K. TREIBS. PAUL E. TREIBS.

**TREIBS BROS.,**

68 Nassau St., New York.

CUTTERS AND IMPORTERS OF

**Opals.**

F. E. TREIBS,

Oberstein, Germany.

ESTABLISHED 1842.

HERMANN TREIBS. ALBERT TREIBS.  
 EMIL TREIBS.

**TO BLOW EFFECTIVELY IS AN ART**

which we never practice personally; but we have invented a machine which does it for us, called the

**"Reichhelm Pressure Blower."**

This, with Gas Furnaces and Jewelers' Tools generally, is the stock in trade of

**E. P. REICHHHELM & CO.,**  
 23 JOHN STREET, NEW YORK CITY.



COPYRIGHT, 1899, BY AMERICAN WALTHAM WATCH CO., REG. IN U. S. PATENT OFFICE.

**DIAMONDS.**  
**Wm. S. Hedges & Co.,**  
 IMPORTERS OF  
**Diamonds and Precious Stones,**  
**DIAMOND JEWELRY.**  
**170 Broadway, New York.**  
 26 Holborn Viaduct, London.

*Oppenheimer Bros. & Veith,*

*Importers and Cutters of*

*Diamonds*

*Dealers in*

*Watches,*

*Cor. Nassau and John Streets,*  
*(PRESCOTT BUILDING.)*

*....New York....*

*Amsterdam,*  
*2 Tulp Straat.*

*London,*  
*45 Holborn Viaduct.*

**MOUNT & WOODHULL,** FORMERLY WITH LATE FIRM OF  
 RANDEL, BAREMORE & BILLINGS,  
 IMPORTERS OF . . .

**Diamonds, Other Precious Stones, Pearls, Etc.,**  
**Makers of fine DIAMOND JEWELRY,**

26 MAIDEN LANE (SOUTHWEST CORNER NASSAU STREET), NEW YORK.

JOHN C. MOUNT.

ADDISON W. WOODHULL.

RUBIES.

SAPPHIRES.

**C. G. MALLIET & CO.,**

EMERALDS.

14 MAIDEN LANE, N. Y.

DIAMONDS.

## The Bowden Rings

ARE COMPLETE IN VARIETY, CORRECT  
 IN QUALITY AND PERFECT IN FINISH.  
 WE MAKE EVERY VARIETY OF FINGER  
 RINGS

**J. B. BOWDEN & Co.,**

1 MAIDEN LANE,

NEW YORK.

### Precious Stones: London Market

HATTON GARDEN, London, Eng.,  
 November 25, 1899.

Still no news of any further advance in rough diamonds. Some of the wholesale houses are reported to be buying again pretty freely. An American buyer interviewed to-day on the eve of going back home stated that he had no fear of any reaction in prices after the war; the Syndicate, he considered, were powerful enough to keep the market prices up. Although business was quiet at present he anticipated a revival in the New Year, January being usually a good month. In reference to pearls he said prices were as high as ever. In reply to a question, he said that, as nearly as he could figure it up, diamonds had advanced 40 per cent in the year.

From Kimberley the cables assure us that the city is "all right." The bombardment at long range has been singularly ineffective from a military standpoint. It appears, however, from certain indications in the cables that the mines are practically closed. This means probably that only the washing, sorting, etc., are carried on. The compounds are apparently still in working order and presumably the convict station is not closed. If my surmises are correct the effect would be to decrease the stock of "blue" ground but keep the production of stones at much about normal state. R. F.

### Sudden Death of Frederick Borgerding.

LOUISVILLE, Ky., Dec. 2.—Frederick Borgerding, the well known jeweler, of Borgerding Bros., was found dead at his store, 422 E. Market St., this morning at 7 o'clock. Coroner McCulloch pronounced death due to mitral obstruction of the heart and said it must have occurred about midnight.

Yesterday afternoon Mr. Borgerding, after playing with his children for some time, went to his store about 3 o'clock. When he left home he seemed in the best of spirits and health. Nothing was thought of his failure to appear at supper for he often remained at the store until late. However, when this morning he had not come home his family became alarmed, and his father, D. H. Borgerding, and Mr. Dillon, a friend, went to investigate. The place was closed, but Mr. Dillon had a key with which he obtained entrance. Mr. Borgerding was found lying on the sofa in the rear of the store. At first it was thought he was asleep. An attempt to awaken him proved that he was dead.

For some time Mr. Borgerding had been a sufferer from asthma and heart trouble. He leaves three small children. His wife left him a widower last year. She died of heart trouble. Mr. Borgerding was a thirty-second degree Mason and a member of Preston Lodge. He was also a member of the Delmont Club. The Masons will have charge of the funeral. He was 35 years of age. In February, 1898, his brother, Frank R. Borgerding, was accidentally killed while cleaning a revolver.

A. L. Campbell, Springfield, Mass., has removed to 485 Main St.

**Retailers in Convention.**

**Canadian Single Line Merchants Discuss Methods for Meeting Department Store Competition.**

TORONTO, Can., Dec. 2.—The annual meeting of the Retail Merchants' Association of Canada was held at the Temple building, this city, on Nov. 27, about 150 persons being present.

W. B. Rogers, the president, delivered an address dealing mainly with the department store question. He thought that in order to cope with the department stores on terms of equality in the purchase of goods, a central organization of retailers should be formed to act as buyers for the respective trades, and thus by purchasing in large quantities secure the lowest terms. The department stores were, by their business methods, enabled to advertise goods so as to operate prejudicially against the single line dealer. By concentrating their attacks upon one particular branch, selling for a time at or under cost price in that line and looking for profits to the other departments, they were able to break down opposition and run their opponents. Thus they had succeeded in driving hundreds out of business, and were rendering it impossible for any young man of moderate means to establish himself independently in trade.

It was the duty of the Government to apply some remedy. With a view to practical action he submitted a list of the different forms in which bills had been prepared in other countries with this object, and spoke strongly in favor of a system of progressive taxation as the best method. If the merchants were properly organized there would be no difficulty in getting such a law adopted by the Legislature.

The legislative committee presented a report favoring a tax on the total annual business turn-over in place of the present personalty tax, differing slightly from the similar proposition presented to the Legislature last session. The report was adopted.

Arrangements were considered for presenting evidence to the committee of the Legislature with respect to the effect of department stores on the business of towns and villages.

Resolutions were adopted in reference to misrepresentation in advertising, recommending that steps should be taken to amend the law so as to make corporations subject to the same laws and penalties as individuals, and condemning the use of trading stamps and similar schemes. A committee were appointed to devise some plan of action with regard to the trading stamp evil.

The following officers were elected: President, John Hargraves, Toronto; first vice-president, W. H. Henry, Kincardine; second vice-president, J. T. Boyd, Ottawa; treasurer, G. E. Gebbard, Toronto; secretary, E. M. Trowern, Toronto.

J. H. Booth, formerly of Gordon & Booth, Laconia, N. H., has started in business in that city on his own account.

G. T. Dutcher, jeweler, late of Baraboo, Wis., has bought the stock and jewelry business of T. R. Mundy, Dodgeville, Wis.

ESTABLISHED 1840.

**Chester Billings & Son,**

Successors to **RANDEL, BAREMORE & BILLINGS,**  
IMPORTERS OF

1840 RANDEL & BAREMORE.  
1856 RANDEL, BAREMORE & CO.  
1880 RANDEL, BAREMORE & BILLINGS.

**DIAMONDS**

OTHER PRECIOUS STONES AND PEARLS.

58 Nassau Street,  
29 Maiden Lane, 22 Holborn Viaduct,  
NEW YORK. LONDON, E. C.

❖ DIAMOND JEWELRY. ❖

...ESTABLISHED 1841...

A. CARTER. C. E. HASTINGS. G. R. HOWE. W. T. CARTER. W. T. GOUGH.

**Carter, Hastings & Howe,**

TRADE  MARK.

MANUFACTURERS OF

**Gold Jewelry,**

9, 11, 13 MAIDEN LANE,

NEW YORK.

FACTORY, NEWARK, N. J.

**Pearls**

**Opals**

Importers and Cutters **GOODFRIEND BROS.,** Precious and Imitation Stones

9-13 Maiden Lane, N. Y.

174 Weybosset St., Providence, R. I.

10 Rue Cadet, Paris.

TELEPHONE, 662 CORTLANDT.

**John F. Saunders,** Cutter and Importer of

**DIAMONDS** AND OTHER  
PRECIOUS STONES.

FINE PEARLS A SPECIALTY.

68 Nassau St., cor. John St., Sheldon Building,  
Room 16, NEW YORK.

## PEARLS.

## Our Experience

in purchasing goods simplifies matters for the discriminating buyer who purchases of us.

He will find exactly the goods he needs, in assortments large enough to admit of careful and successful selection.

## Alfred H. Smith &amp; Co.,

182 Broadway, N. Y.

CHICAGO.

LONDON.

## DIAMONDS

And Other Precious Stones.

## NISSEN

*Ludwig Nissen.*



18 JOHN ST. NEW YORK

We carry the largest, finest and most complete line of Mounted Diamond Jewelry of any house in America.

## Elgin Watch Co. Raise Wages.

The Elgin National Watch Co. Decide to Allow Their Employees to Share in Their Prosperity.

CHICAGO, Ill., Dec. 2.—“On Jan. 1 it is proposed to put in effect a readjustment of rates for day work and prices for piece work throughout the several departments of this factory, restoring the general average to the figures that each obtained for the fiscal year, 1892.”

The above notice was posted at the Elgin National Watch Co.'s factory Dec. 1, and came as a surprise to the employes, as the action was entirely voluntary on the part of the company. When President Hulburd assumed his office in December, a year ago, he met and talked with the employes of the factory, and then stated that it was his policy to restore wages to the 1892 schedule as soon as possible. All his efforts since have tended in that direction, and Dec. 1 he telephoned to the superintendent to post the above notice in the various departments of the factory.

In the past year there has been a complete rearrangement of some of the departments, notably the assembling room, and previous to the latest order a general raise in the lowest wages of fully 6 per cent had been effected. The restoration of the wages to the 1892 basis will be by a readjustment of each separate job, which is considered fairer to the employes than a horizontal advance throughout the works. By the proposed readjustment the company will pay to their employes \$120,000 a year more than they now receive, in which every employe at the factory will share. The wages now earned will be compared with the wages earned in 1892, and matters so arranged that the wages of the latter year can be earned without overwork on the part of the employes.

In commenting on the raise President Hulburd said to the THE JEWELERS' CIRCULAR representative: “I am a believer in the old adage that a workman is worthy of his hire. The company have had a successful year, and our employes have been faithful to our interests. We feel that they are entitled to share in the general prosperity. The feelings of the employes and the management have ever been of the most friendly nature, and it is only a question of right that they should share in the earning power of the factory.”

## This Bold Diamond Thief Nearly Won His Game.

KANSAS CITY, Mo., Nov. 28.—Last evening a tray containing over \$700 worth of diamonds was stolen from jeweler J. B. Schmeltz, 1231½ Grand Ave., and it was only by good luck that the diamonds and thief were secured.

About 6 o'clock last evening a man called at Mr. Schmeltz's store and requested him to show him some diamonds. He said that he desired to purchase a diamond engagement ring. On being shown a tray containing 12 rings he asked to be shown some others, as those shown were too expensive, ranging in price from \$50 to \$100. He said there was one in the window that suited him, and Mr. Schmeltz reached



in the window for it and turned around just in time to see the man and tray disappear out of the door.

At that time two policemen noticed a man running across the street, and as there was no car in sight, they thought it looked suspicious and gave chase. The thief, seeing the officers coming, concealed the tray in his pocket, and ran into an alley, but by chance stumbled and fell, so the officers managed to secure him. By this time Schmeltz appeared and told of the robbery; all of the diamonds were secured except two which the thief lost in his run. The thief gave his name as F. P. Montrose and claims to have come from Texas.

In May, 1897, this same store was robbed. At that time it was owned by Le Roy Garton, and the robbery was attempted in about the same manner, only Mr. Garton caught and held onto one of the thieves, being severely beaten in so doing. These two thieves were Jim Conside, who was sent to the penitentiary, and J. Williams, who was sent back to Tennessee to serve out an unexpired term there.

**Bicknall & Wood Co.'s Stock Sold Out to a Department Store.**

PROVIDENCE, R. I., Dec. 3.—The entire stock of goods in the store of the Bicknall & Wood Co., 359 Westminster St., whose assignment to C. Frank Parkhurst was announced in the last issue of THE CIRCULAR, has been purchased by Shepard & Co., operators of one of the largest department stores in this city. The announcement of the transaction, which is an important one, covering a large stock of silver ware, cut glass, china, bric-à-brac, etc., was made today.

John Shepard, of Shepard & Co., informed THE CIRCULAR correspondent that the work of removing the goods from the Bicknall & Wood Co. store had already begun. He stated further that Messrs. Bicknall and Wood would both be associated with Shepard & Co. hereafter, as would also a number of the former concern's salespeople, and that the stock just purchased would be placed on sale immediately.

Ed Hoffman, a skilled jeweler, has returned to Ocala, Fla., from Spartanburg, S. C., and again taken service with A. E. Burnett.

**Developments in the Attempted Robbery at A. E. Siedle's Store.**

PITTSBURGH, Pa., Dec. 2.—The representative of THE CIRCULAR secured to-day from Roger O'Mara, Superintendent of Police, photographs and descriptions of the two confederates in the A. E. Siedle diamond robbery of Nov. 24, as shown below:



**Two of the Thieves Who Attempted to Rob A. E. Siedle, and Who Are Still at Large.**

Charles Hoyt, crime, robbery; age 35; height 5 ft. 6 1/4 inches; weight 160 lbs.; build stout; hair dark chestnut; eyes dark blue; complexion medium dark; dark moustache; born Philadelphia; occupation salesman; scar on right index finger; bald on top and crown of head.

William Devlin, age 23; height 5 ft. 6 inches; weight 132 lbs.; build slender; hair dark blond; eyes dark blue; complexion medium dark; born New York; occupation waiter; scar on left wrist.

James Reilly, the diamond thief, was given a hearing on Nov. 28 before Magistrate Bernard McKenna. The testimony regarding the robbery was substantially that of the story already published in THE CIRCULAR. Robert Miller, the young salesman who was in the store when the robbery happened, positively identified Reilly or Robinson as the man who had taken the tray of diamonds. Reilly was represented by attorney James F. Burke, who made the ineffectual plea for his client's discharge that the testimony did not show that any goods had been taken from the store. However, the accused was held in \$2,000 bail for court to answer a charge of entering a building to commit a felony.

Reilly has been positively identified as

the principal in a diamond robbery that occurred in Philadelphia on Jan. 14, 1898, when 23 diamonds were stolen. He was sent to the penitentiary for that, with his accomplices, James Sullivan, William Devlin and Charles Hoyt, who got 15 months each. Reilly has been at liberty two months, his time having been shortened for good behavior. It has also been ascertained by Superintendent Roger O'Mara that Reilly was mixed up in several other robberies of a similar character before his arrest in Philadelphia.

Detective McGovern, who made the clever arrest, has also recovered the only missing \$300 ring, and returned it to Mr. Siedle.

**Mysterious Robbery of Daniel Earl.**

CHICAGO, Ill., Dec. 2.—No trace has been found of the thief who, it is supposed, extracted a pocketbook of precious stones from the pocket of Daniel Earl, on State St., Nov. 25. At 4.30 o'clock p. m. that

day Mr. Earl started for his home in Englewood and was anxious to make the train. He put the pocketbook of stones into his outer left hand overcoat pocket and put bundles he was taking home on his left arm. After waiting for a moment for an elevator he rode down, and on the way felt for the pocketbook and it was there. He talked with a friend on the elevator and on reaching the street started north on the west side of State St. to place the stones in the Masonic Temple safety vaults for the night. When at Washington St. he again felt his pocket, and the book was missing. The contents were all uncut stones, and comprised diamonds, rubies, sapphires, emeralds and various other colored stones, aggregating in value between \$7,000 and \$8,000. Detectives were at once put on the

SCIENTIFIC RUBIES	OPALS	OLIVINES	CATSEYES	SAPPHIRES	DIAMONDS	RUBIES	EMERALDS	PEARLS	PEARL NECKS	PEARL ROPES	Pearl Collarettes, mounted with Diamond Bars.	
			<p><b>PEARLS, DRILLED AND UNDRILLED.</b></p> <p><b>PEARL ROPES, NECKS and COLLARETTES.</b></p> <p><b>We are buyers of American Pearls.</b></p>									
			<p>LONDON: <b>JOSEPH FRANKEL'S SONS,</b> 68 Nassau Street, NEW YORK.</p> <p>19-20 Holborn Viaduct. TELEPHONE, 3899 CORTLANDT.</p>									
			<p>FANCY COLORED DIAMONDS and GEMS in PEARLS and PRECIOUS STONES.</p>									



## Selections of Diamond Jewelry.

Write to us for  
Diamond Jewelry on  
memorandum.

We fill all orders  
the same day as received  
and you never miss a

sale when you show our goods.

Try us once and you will do so again.

*Kohn & Co.*  
9.11.13 MAIDEN LANE.  
NEW YORK.



“The  
Pearl  
House.”

We have no salesmen:  
call or write.

**EISENMANN BROS.,**

PARIS, 3 Rue St. Georges.

21 & 23 MAIDEN LANE, NEW YORK.

## Rubies and Emeralds.

BYRON L. STRASBURGER & CO.,

Watches and Diamonds,

17 MAIDEN LANE,

NEW YORK.

case, but so far their efforts have not availed in turning up a clue to either stones or thief.

Mr. Earl is in business as Earl & Co. on the ninth floor, Champlain building, and sells precious stones to city retail and manufacturing jewelers. He came from Australia some years ago and first engaged in business in this country as a seller of opals and traveled to the larger cities. Five or six years ago he settled in Chicago and has had an office here since, making occasional trips out of town.

### Two Fires in the Jewelry Manufacturing Trade of Providence.

PROVIDENCE, R. I., Dec. 3.—John T. Cuddy & Co.'s jewelry shop, corner of Calender and Mason Sts., was visited by fire shortly after midnight Thursday morning. The injury resulting from the fire itself was comparatively slight, but the water damage was more considerable, particularly in the shop of R. G. Shutz, diesinker, which was flooded by the water which leaked down from the floors above. The loss would have been much greater, however, but for the good work of the protective department in spreading covers. Silverman Bros. also received some damage to their stock of jewelry in their shop on the fourth floor of the building by reason of the dense smoke.

Fire was discovered at about 4 o'clock this morning in the jewelry shop of Babcock & Stone, fourth floor of the factory building, 409 Pine St. The prompt sounding of the alarm and the equally prompt and effective work of the fire department nipped in the bud what might easily have been a serious conflagration in the jewelry district. When the firemen reached the blaze they found that the flames had gotten a firm hold on the woodwork underneath the bench at the south end of the shop, but by the quick use of the chemical succeeded in extinguishing the blaze before any material damage had been done. The building is a part of the property of Leander Peck, and the loss is well covered by insurance.

### Syracuse.

The demand for good watchmakers exceeds the supply in this section of New York State.

Owing to a steadily increasing business Hitchcock & Morse have been obliged to move their optical department to rooms on the floor above their present location, as the space it occupies is needed for increased office facilities.

In 1848 the Onondaga Co. Agricultural Society gave as premiums at their county fair thin, oblong shaped medals of sterling silver which were made and engraved by Becker & Lathrop. A few years later one of these silver pieces came again into the hands of Daniel Becker, the senior member of the firm, through a purchase of old silver, and by him was used to open watch cases until his death some six years ago. It is now carried as a pocket piece by Charles L. Becker, who succeeded his father in the firm of Becker & Lathrop.

**A Grab Thief Makes Off with a Tray of Rings from Jas. L. Litchfield's Store.**

STAMFORD, Conn., Nov. 30.—A daring robbery occurred shortly after 6 o'clock last Thursday evening, when a man got away with \$200 worth of gold rings from the store of James L. Litchfield, 30 Gay St., and made his escape by running across lots and through the yards.

While Mr. Litchfield was alone in the store a fairly well dressed man wearing a light brown suit, no overcoat and a black derby hat, came in and asked to look at some rings. Mr. Litchfield recognized the fellow. He had been in the night before just about the same hour, and after looking over some rings left the place remarking that he wanted to go elsewhere and see if he could do better, and if not he would return later and get what he wanted. When he asked to see the rings Mr. Litchfield placed a tray on the show case, and after the fellow had looked at them a few minutes he picked up the tray, holding about 50 gold rings, and ran for the door, after telling Mr. Litchfield he could go to a place warmer than Stamford is. The fellow ran to the street closing the door as he did so. Mr. Litchfield was obliged to walk to the other end of the counter to get around, and started in pursuit, crying "stop thief." Mr. Litchfield, realizing that no one was left in his store, and thinking that the fellow might have an accomplice who would loot the place, returned and gave up the chase.

Next morning Mr. Litchfield and an officer went over the ground and found four of the rings which had been dropped. In

the meantime word had been sent to Police Headquarters and Chief Bowman, with his corps of officers, instituted a search over the town. Mr. Litchfield went to the depot, where he watched the outgoing trains. The description given by Mr. Litchfield answered that of Anthony Murphy, a well known character of the growler gang, and an officer tried to find him. He met Murphy and took him to police headquarters, where he met Mr. Litchfield, who said he was not the man.

**The Wife of the "Barley King" Accused of Trying to Defraud Her Creditors.**

MONTREAL, Que., Nov. 28.—The hearing of Mrs. O'Neil, wife of Henry O'Neil, of Chicago, a well known plunger, known at one time as the "Barley King," by her maiden name, Evangeline Claire, of Chicago, charged with having swindled different firms of over \$30,000 in jewels and dresses, was resumed to-day.

Godfroi Lafontaine, bailiff, testified that he had been charged some time ago to serve a writ of attachment before judgment on the accused for some goods which she had in eight large trunks at the Windsor Hotel. The contents were composed of articles of great value. The greatest part of all these articles seemed to be new. He did not notice any jewelry. The goods he saw he would estimate at least \$5,000 or \$6,000. There was on the part of the defendant no attempt to secrete the goods. At this point Mr. Markey, representing Mrs. O'Neil, remarked the goods of his client were bought on

running account. Some were bought in Paris, some in Baltimore, in fact, everywhere she had traveled.

Judge Chouquet remarked that it was proven that the defendant had more wearing apparel than the law allowed, but, on the other hand, the prosecution had not made any proof of secretion. The prosecution, which was represented by J. E. Martin, who was present with William Willhartz, of Ringer & Willhartz, Chicago, contended that it was in a position to prove intention to defraud by confidences made to this effect to one of Mrs. O'Neil's maids by Mrs. O'Neil herself. The Judge said he would wait further particulars from the commission in Chicago, and the case was remanded.

**QUANTITY OF GOODS OBTAINED BY MRS. O'NEIL SEIZED.**

DETROIT, Mich., Dec. 2.—The police this week seized two packages at the Oakland County Savings Bank, Pontiac, Mich., deposited by Mrs. Evangeline Claire O'Neil, arrested at Montreal at the instance of Chicago merchants. She is charged with defrauding them out of a large quantity of silver, jewelry and other goods. The goods were placed with the Union Trust Co., of Detroit, and the proper officers opened them on Saturday, and found over \$8,000 worth of fine laces, linens, jewelry and silver ware. The silver ware was just as delivered from the stores, but the purchaser had engraved the family monogram deeply into every piece, making it practically worthless except for the melting pot.

ALVIN L. STRASBURGER.

Established 1849.

SOL. KAISER.

**LOUIS STRASBURGER'S SON & CO.**

9-13 MAIDEN LANE, NEW YORK.

**...DIAMONDS...**

**PEARLS,**

**SAPPHIRES,**

**RUBIES,**

**EMERALDS,**

**MARQUIS DIAMONDS.**

CHICAGO, ILL., 103 State Street.

PARIS, 25 Boulevard Haussmann.

**Plate Camera Manufacturers Combine and Effect an Organization.**

ROCHESTER, N. Y., Dec. 1.—This morning there were filed in the Secretary of State's office at Albany and in the County Clerk's office here articles of agreement of the Rochester Optical & Camera Co., to have a capital of \$3,500,000. The company start off with a capital of \$2,000,000, which will all be subscribed by Rochester financiers. The company formed to purchase the plants of the Rochester Optical Co., the Rochester Camera and Supply Co., the Monroe Camera Co., the Ray Camera Co., of Rochester, and the Western Camera Mfg. Co., of Chicago. The new company hold options on these properties, and it is proposed to close up two or three of the factories and centralize the business in this

city. The concerns mentioned are said to manufacture 85 per cent of the plate cameras in the United States.

The officers in Rochester are W. F. Carlton, president, and H. B. Carlton, treasurer. The names of the directors of the corporation for the first year are William F. Carlton, Harvey B. Carlton, Rufus K. Dryer, Benjamin E. Chase, Edward W. Peek, Vincent M. Smith and Frederick P. Allen. The principal business office of the corporation is to be located in Rochester, N. Y.

M. L. Comfort, Owego, N. Y., started an auction sale Dec. 4, as he "wishes to make a radical change in his business." J. H. Mitchell, of New York, is the auctioneer.

**Bet Over Weight of Diamonds Takes Two Experts into Court.**

PHILADELPHIA, Pa., Dec. 2.—Two diamond experts, one well known in New York trade circles and the other a merchant in this city, are at odds over a wager and have appealed to Magistrate Cunningham to settle the dispute, and though the latter is one of the most astute of the minor judiciary, the case has become so much entangled in a mesh of legal technicalities that he is at a loss how to decide the bet.

The parties to the wager were J. A. Ross, jeweler and diamond dealer, 9th and Race Sts., and Meyer Alexander, diamond dealer of New York. Some days ago while Ross was in his shop Alexander came in and offered to sell him a pair of diamond earrings for \$500. Ross appraised the stones and offered \$250 for them. Alexander lost his temper and, after high words, took a pin from his cravat and said:

"Now, will you give me \$500 for the earrings with this thrown in?"

Ross examined them carefully and concluded: "They are not worth more than \$350 at the most."

Alexander was furious. Striking his fist on the table he offered to wager \$100 that the three stones would weigh more than nine karats. Ross took the bet and scales were produced. The three stones were weighed before several persons. Their weight was a fraction less than nine karats.

Alexander started a row at once, declaring that Ross had taken \$100 which he claimed to have left on the counter, and rushing to Magistrate Cunningham's office swore out a warrant for the arrest of Ross. Next morning at the hearing the stones were again weighed and still were short of nine karats.

Obsolete and antique laws have been thrust upon the Magistrate for consideration, and he was to have decided Saturday, but Alexander was away on business and couldn't be present. Since then it has been suggested that the bet be called off. Alexander assented cheerfully, but Ross would not touch his share, and stormed: "I'll have it all or none. If it was a bet it was a real bet. I've won and I'll fight till I get the money."

G. DeW. Babcock, Quincy, Mich., is conducting an auction sale, as he is going out of business.

The Burlington R. R. has changed the plan for registering trainmen's watches. Hereafter the principal record of each watch will be on a card kept by its owner which he will present to the watch examiner at each examination and which will be filled out by the examiner. Each card will last three months.

Geo. Gordon, jeweler, Haverhill, Mass., is minus a diamond ring, valued at \$85, and an opal ring, worth \$34. Mr. Gordon was cleaning some lights in his store last Saturday afternoon, and had taken the rings from his hand. Two young men came in and asked to look at some watches. Mr. Gordon went to the window, and after showing some watches, the men left, taking with them the rings.

## In Three Weeks

Christmas will have come and gone; to make the three weeks thoroughly remunerative you must sell many diamonds, and to aid you in doing this we offer you the assistance of our Diamond Department, the resources of which are very extensive.

Our stock of MOUNTED DIAMONDS was never so full—use it to buy from, use it to make sales from, use it often.

EMERALDS, RUBIES, OPALS,  
SAPPHIRES, PEARLS,  
TURQUOISES.

**HAYDEN W. WHEELER & Co.,**

**TWO MAIDEN LANE, N. Y.**

50 HOLBORN VIADUCT, LONDON.

**Export Exposition Awards.**

**List of First Awards for Exhibits of Interest to the Trade.**

PHILADELPHIA, Pa., Dec. 3.—A partial list of the exhibitors at the National Export Exposition winning the silver medal and diploma of the exposition was made public by the department of awards to-day. None of the juries of award has yet made a final report. The silver medals will not be ready for issue to the winners until some time early the coming year, as the dies have not been cut.

The judges have also the power to award diplomas of honorable mention, and a list of the exhibitors so honored will be ready in a few days.

In addition to the medal or diploma of honorable mention the judges may recommend the reference of exhibits to the Committee of Science and the Arts of the Franklin Institute for further examination, with the view of the grant of the Edward Longstreth silver medal of merit, the John Scott premium and bronze medal, and the Elliott Cresson gold medal.

**SILVER MEDALS AND DIPLOMAS.**

J. E. Caldwell & Co., Philadelphia, have been awarded the silver medal for gold, silver and plated ware.

C. F. Rumpp & Sons, silver medal for carved leather goods.

Libbey Glass Co., Toledo, O., silver medal for glass ware.

Pittsburgh Plate Glass Co., Pittsburgh, Pa., silver medal for glass ware, cut and pressed.

PHILADELPHIA, Pa., Dec. 5.—Following additional awards of silver medals were made to-day:

Bausch & Lomb Optical Co., Rochester, N. Y.

W. E. & J. E. Gurley, Troy, N. Y., surveyors' instruments.

Queen & Co., Inc., Philadelphia, scientific instruments.

**L. M. Sigler Now Offers \$5,000 for the Return of His Gems.**

CLEVELAND, O., Dec. 2.—L. M. Sigler has offered a reward of \$5,000 for the return of the \$18,000 worth of diamonds stolen from his store and no questions asked. Mr. Sigler told THE CIRCULAR correspondent that he was in hopes the thieves would accept this method of disposing of the gems, as it was probably as much as they could realize through a "fence."

**Two Cincinnati Jewelry Stores Burglarized.**

CINCINNATI, O., Dec. 4.—Two Arcade jewelry stores were burglarized Sunday night, those of S. B. Duncan and Louis F. E. Hummel; jewelry, silver ware and watches were taken. The burglars bored a hole through the basement wall. The loss is estimated at several hundred dollars.

**Gifts for Men**



In 14-Karat Gold—ORNAMENTED WITH PRECIOUS STONES—and in Sterling Silver. Goods that appeal to refined people at all times. Made handsomely, heavy and exclusively for the Jewelry trade.

**Woods & Chatellier,**  
Gold and Silversmiths.

860 Broadway, N. Y.  
42-46 Hill St., Newark, N. J.

**MATHEWS & PRIOR,**

DESIGNERS AND MAKERS OF

**Sterling Silverware**

TO THE LEGITIMATE

**JEWELRY TRADE ONLY,**



245-247 West 28th Street,  
New York City.

**Pearl Perfection.**

Perfect in quality, perfect in assortment, our stock of Pearls is one of the largest owned by any house in America.

**Fred. W. Lewis & Co.,**

No. 1 MAIDEN LANE (Cushman Building), NEW YORK.

**Stern Bros. & Co.,**

Cutters of . . .

MANUFACTURERS OF

**DIAMONDS,**

Gold Rings and Thimbles,

68 NASSAU STREET, NEW YORK.

RING FACTORY, 33-43 GOLD STREET, NEW YORK.  
DIAMOND-CUTTING WORKS, 142-146 W. 14TH ST., NEW YORK.

LONDON OFFICE, 29 ELY PLACE.  
CHICAGO OFFICE, 149 STATE ST.

**JAMES KAHN'S SONS,**

PARIS: 7 RUE CADET.

IMPORTERS AND CUTTERS OF DIAMONDS,

Amsterdam, 2 Tulp Straat.

12, 14 & 16 John St., New York.

## A Striking Innovation

in watch case engraving and one that will appeal most strongly to your customers is the case illustrated below.

On a Bell Gold-Filled Watch Case you can have engraved any portrait or group that may be desired—an exact reproduction of the photograph engraved in the case.



Send on a photograph and let us engrave a sample case for you. Then you will see the great advantages that accrue to you when you

**Buy of the Maker.**

**THE BELL WATCH  
CASE CO.,  
CINCINNATI, OHIO.**



**DEITSCH BROS.,**  
14 East 17th St.,  
New York.

**LEATHER. SHELL,  
EBONY, IVORY.**

**H. M. RICH & CO.,**  
**Jewelry - Auctioneers,**  
**7 and 9 Franklin St.,**  
**BOSTON, MASS.**

DON'T FORGET THE JEWELERS' CIRCULAR PUBLISHING CO.'S BOOK LIST when in want of any technical work in the Jewelry or Kindred Trades.

### Death of Harlie Bliss Harper.

GREENVILLE, O., Nov. 29.—The funeral of Harlie Bliss Harper took place Sunday afternoon from the residence of his father. There was a large outpouring of friends and relatives to pay tribute to the memory of the deceased.

Harlie Bliss, son of William M. and Helen A. Harper, was born in Greenville, O., on Feb. 17, 1869. Here he passed the years of his boyhood, was educated in the public schools and learned the trade of his father, that of jeweler and engraver. He was an able workman, and from his very early manhood in Kansas City, Mo., Dayton, O., and Atlanta, Ga., he had remunerative employment till failing health several months ago compelled him to give up his position and go to Arizona in quest for health. Twelve years ago he was united in marriage to Miss Bessie Mitchell, of Piqua. Two daughters, with their mother, survive him. He was greatly esteemed by all who knew him.

### Three Mercantile Swindlers Sent to Jail.

PITTSBURGH, Pa., Dec. 4.—Adolph Blau, Jacob Green and Jacob Rifkin, of Wilkes-Barre, Pa., who were recently convicted in the United States Court, in this city, of using the mails to defraud jewelers and other merchants, have been sent to jail. Blau was sentenced to serve 11 months, and Rifkin and Green were each sentenced to eight months. These men were members of a gang of alleged swindlers, whose scheme was to get goods from various wholesale merchants, including jewelers, without any intention of paying for them.

The business of W. H. Craig, El Paso, Ill., who recently died, is closed.

Thomas M. Hannah, Belvidere, Ill., has transferred his business to his wife, Mary L. Hannah.

### Tariff Decisions.

OLD DUTY ON CASES CONTAINING GOGGLES.

The Board of United States General Appraisers last week decided an old protest filed by L. Hammel & Co. (now Hammel, Riglander & Co.), involving the duty on cases containing goggles under the tariff law of March 3, 1883. The merchandise was imported July 22, 1890, and was assessed for duty at 100 per cent. They were claimed to be free of duty as the usual coverings for the goods and the Collector in his report to the Board says that in view of certain decisions "it would appear that these cases were entitled to free entry as the usual and necessary covering of the merchandise. The claim set forth in the protest would, therefore, appear to be well founded." The Board decided in accordance with this recommendation and sustain the protest. The action imposing the duty is reversed with instructions for an appropriate re-liquidation.

### Lancaster, Pa.

The Hamilton Watch Co. shut down for Thanksgiving day, but started up very active on Friday morning.

Messrs. Smedley and Williams, managers of the L. C. Reisner & Co. branch store in Philadelphia, were the guests of Mr. Reisner on Sunday and Monday.

J. C. Hahn, of the material department of L. C. Reisner & Co., has left on a southern trip in the interests of this house, taking the place of F. A. Wheeler, whose illness still confines him to his home. Mr. Hahn expects to finish his trip in time to return for the holidays.

The local trade was called upon the past week by Joseph D. Varley, Allsopp Bros.; J. A. Browne, Reeves & Browne; L. E. Brushaher, canes and umbrellas, Townsend, Desmond & Voorhees Co.; H. Grabowski, Dattelbaum & Friedman; Harry Lissauer, Ingomar Goldsmith & Co.

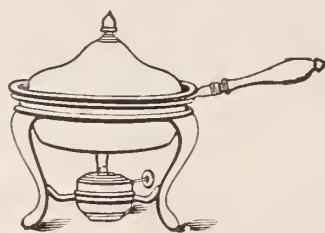

**WHY  
WAIT?**



The holiday trade promises to be the largest in the history of the country. We are far behind our orders, and any goods you may want for

**CHRISTMAS, ORDER NOW.**

Our new illustrated catalogue sent on application.

**S. STERNAU & CO.,**

Manufacturers of Metal Wares in Brass, Copper and Silver,  
204 Church Street, New York City.

**IMMUNITY AGAINST THIEVES.**

**HOW THE MAIDEN LANE DISTRICT IS GUARDED  
—SOME VALUABLE HINTS TO  
JEWELERS.**

THE recent daring robberies by jewelry thieves in various cities of the United States have, by contrast, called attention to the almost absolute security enjoyed by the merchants of the jewelry district of New York. With the enormous amount of stock and property concentrated within the confines of the four square blocks familiarly known as the "Lane," it is no wonder that foreigners and visitors to the metropolis are amazed to see with what little fear, and, in fact, with what perfect confidence thousands of dollars' worth of diamonds and jewelry are carried around from place to place. This condition, perfectly understandable to the New York jeweler, is almost incomprehensible to any one who does not understand the methods taken for the protection of this valuable district from invasion by the crooks. Though so apparently easy of access, this district to the ordinary crook is almost as difficult to enter as would be the Dardanelles to a warship of the Sultan's enemy. The proof of this will be found in the fact that not one important robbery in the vicinity of the "Lane," committed by a professional thief, can be recalled as having taken place within the past 15 years.

The system for the protection of the "Lane" is simple, and it lies in the fact that two detectives, to whom is personally known every dangerous jewelry crook who has operated in the United States, are constantly on the watch and patrol this district during the entire business term of the day. The work of these men, important as it is to hundreds of merchants, is but little known and less understood, for their efficiency lies not only in the detection but in the prevention of crime. Hardly a month goes by but some crook, attracted by the enormous wealth apparently lying around loose in the vicinity of the "Lane," dares the danger which he knows lies there and attempts to go by the so-called "dead line." Before he passes John St., however, he finds himself spotted by one of the two "watch dogs" of the trade, and is either taken to court or to Police Headquarters. These arrests, which in nearly every case prevent the possibility of one or more large robberies, are hardly ever heard of.

This system of prevention was started over 20 years ago, when Thomas Byrnes was the Chief of the Detective Bureau, and has continued up until the present time. The jewelry district, as is well known, includes John St. and Maiden Lane, and runs from Broadway to William St. The remainder of the city below this part, between Broadway and Pearl St., is known as the banking district or "Wall St." In these two districts are to be found the "wealth of empires," so the necessity for its absolute protection is readily seen. For this reason the so-called "dead line" was established many years ago at John St., and a professional crook has seldom been able to get below this street without difficulty, unless his errand

has been a legitimate one. The "Wall St." district, which is large in area, has about 25 Central Office detectives detailed throughout it, while the Jewelry district, comprising less than two square blocks, has but two. These latter at the present time are Detective-Sergeants Andrew Nugent and Thos. E. Madden, whose clever work and untiring energy deserve the gratitude of the entire trade. While it is true that with the exception of the thief arrested Nov. 23, no professional crook has operated in the jewelry district within the past year, it is on the other hand not known that over a dozen dangerous professional crooks have been captured within the same time and taken out of the district before they had time to do any harm. The safety of the merchants in the "Lane" becomes greater each year in proportion as the knowledge is distributed among the thieves that to rob the "Lane" is impossible, and it will probably be but a short time before even attempts to get within the precinct so well guarded will no longer be made. From their constant work in the trade, Detectives Nugent and Madden have become familiar with almost all of the people who have business in the district, and strangers are by them easily detected. All who are not unmistakably shoppers are to a more or less extent watched, and if they commit any suspicious acts they are followed.

Whenever an arrest is made of a man known to be a dangerous operator, he is taken to Police Headquarters and there inspected by the entire staff of detectives, so that they may be familiar with his appearance and characteristics. This is also done to find out if any of the detectives wish him held for any crimes past or present. In this way and by means of the photographs sent out by the police authorities, the detectives become familiar with nearly all crooks known as dangerous and who appear to be especially enterprising, and in addition a record is kept by the department by which they know where many of these thieves are when their prison terms expire and when they will likely be at large.

At the present time there are known to be about 50 expert professional jewelry thieves, men who make no blunders and who know all about the trade. These men are watched for especially. It may be incidentally remarked that the expert women thieves, who were prominent in the robberies of years ago, are no longer so, nearly all having disappeared from the business. It is a peculiarity that women thieves and shoplifters never work alone, but either in partnership with a man or with another woman. Where the man and woman work together, the thief, or "touch," is generally the woman, while the man goes as a decoy or "stall." "Penny-weighters" are the most expert of thieves and are among those who are most dangerous to the jewelry trade. Their mode of procedure is generally to visit a store to get an idea of certain parts of the stock, have a substitute made for some piece, and then return with another person presumably to purchase. The same goods are asked for and shown to the "penny-weighters," who then substitute the imitation for the real. This game has not been worked so much of recent years

**Best "HOLIDAY" Sellers**

The Patented,  
Adjustable, Combination

**NECK  
AND  
GUARD CHAINS**  
FOR  
Watches, Lorgnettes or Fans.



*Perpetual injunctions against  
infringements issued by the U. S.  
Court, Boston, Nov. 20, 1899.*

**ALL WHOLESALE HOUSES  
carry a full line.**

Jewelers desiring to advertise  
"MARCELLA" chains in their  
LOCAL PAPERS will be fur-  
nished with *Electrotypes*, free  
of charge, by addressing

*Jissauer & Company*  
12 MAIDEN LANE

P. O. Box 2516.

NEW YORK.

# Simplicity of Construction

combined with superior workmanship, is what makes the

## Trenton Watches

the most reliable of all low-priced movements.



12-Size Trenton, 7 Jewels, Stem-Winding, Lever-Setting, Hunting, (open face) without second hand. Supplied in Silver and 5-year Gold-Filled Cases.

The "Trenton," for the price, far surpasses any movement ever placed upon the market.

SEND FOR PRICE-LIST.

The Trenton Watch Co.,  
Trenton, N. J.

**ESTABLISHED 1840**  
**TRADE MARK**  
**PHILA. NEW YORK CHICAGO**  
**SILVERSMITHS, JEWELERS.**  
**MAKERS OF GOLD AND SILVER THIMBLES.**

### CASH OFFERS.

If at any time you have offered to you by your customers any Jewelry containing diamonds, pearls or other precious stones, and you do not care to buy them yourself, send them to us and we will submit an IMMEDIATE CASH OFFER. Trade and Bank References if desired. Established 1880. Correspondence solicited.

CHARLES S. CROSSMAN & CO.,  
3 Maiden Lane, New York.

as formerly, but several "penny-weighters" are still operating.

The question will undoubtedly be asked: "Are there no new thieves coming into the trade to take the place of those who are disappearing?" and the answer is, of course, "Yes." The trade is protected against the newcomers, however, by the fact that the amateur is more easily detected and arrested. Also, when the arrest of a man or woman who appears to have the making of a dangerous character in his or her disposition takes place in any part of the country within a reasonable distance of New York, the detectives especially employed in the jewelry district are sent to examine and study the thieves while they are awaiting trial. If the arrest be too far away for this, a photograph is generally obtained, together with the peculiarities of the methods employed and the characteristics of the operator.

In conclusion it may be well to call attention to the fact that the holiday season is the most dangerous time to the jeweler, and the time most often employed by the professional crook for his work. This is accounted for by two reasons: First, the enormous crowds of shoppers that throng the stores at this time make detection and capture more difficult; and second, at this season the jeweler carries a larger and more valuable stock than at any other period of the year. A few well known maxims of warning, therefore, are not out of place, and should here be reiterated:

First, the jeweler should be alone in his store as little as possible.

Second, he should never serve more than one customer at a time.

Third, he should be constantly on the watch and have an extra person watching, if possible.

Fourth, he should be especially suspicious of a customer who handles a handkerchief or gloves while examining stock.

Fifth, he should never show a large number of pins, or small pieces loose, and never attempt to take out one lot of goods until he has put back those he has been showing.

By following these rules he will avoid many robberies which are perpetrated by the simplest methods employed by crooks.

### Last Week's New York Arrivals.

THE CIRCULAR has perfected arrangements for obtaining the names and hotel addresses of all the latest buyers visiting New York, and each day posts in its office, 11 John St., cor. Broadway, a bulletin which every member of the trade is cordially invited to copy.

Boston, Mass., A. W. Paul (A. Paul & Co), Marlborough.

F. G. Butler, Park Ave.

Barre, Vt., O. J. Dodge, Gd. Union.

Cincinnati, O., O. Keck (H. Keck Mfg. Co.), Astor.

Cleveland, O., O. L. Mason (Hower & Higbee), Gd. Union.

Detroit Mich., C. F. Hammond, Holland.  
Greensburg, Pa., L. Furtwangler, Gilsey.  
Milwaukee, Wis., A. W. Neisser (Neisser Jewelry Co.), Hoffman.

Montreal, Can., B. C. Silver, Astor.

Philadelphia, Pa., W. H. Thompson, Bartholdi.

Pittsburgh, Pa., L. Jacobson (Jacobson & Rosenthal), Marlborough.

Richmond, Va., S. Hirsh (M. Millhiser & Co.), 258 Church St.

Toronto, Can., T. G. Kent, Imperial.

Torrington, Conn., J. B. Lyon, Gd. Union.

York, Pa., I. I. Cohen (Cohen & Pirosh), St. Cloud.

C. M. Carpenter, Brandon, Vt., has again improved the interior of his jewelry store.

## S. C. POWELL, 51 & 53 MAIDEN LANE, NEW YORK.

### STERLING SILVER NOVELTIES.



Nail Polisher. Sterling Silver Mounted. No. 42. Per doz., \$5.50.



Sterling Silver Pocket-Knife. Best grade steel. No. 243. Per doz., \$3.00. Ladies' size, \$2.75.



Vinaigrette. Imitation Cut Glass with Sterling Silver Screw Top. No. 806. Price, per doz., \$2.00.

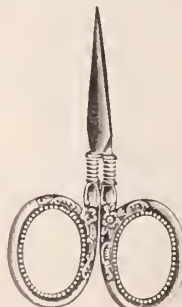

Sterling Silver Scissors. Embroidery or Manicure. No. 923. Price, per doz., \$4.88.



Match Box. Sterling Silver, Satin or Polish. No. 597. Price, each, 75c. Per doz., \$9.00.

Prices subject to 6 per cent discount.

Send for our Fall Catalogue.



**Philadelphia.**

R. W. Quicksall has opened a new jewelry store in Mt. Holly.

The Little Jet Jewelry Store, 12 N. 8th St., was among the firms burnt out by the big fire Wednesday last.

There is a well defined demand in the local trade for silver flower bowls with a net work of silver across the mouth, as bridal gifts.

Among the buyers in town last week were: H. V. Stratton, Mt. Holly, N. J.; Gus Rietzen, Ashland, Pa., and F. H. Fry, Burlington, N. J.

S. S. Kind was last Thursday granted letters of administration on the estate of his wife, whose sudden death was reported in these columns last week.

The magnificent tea set and silver chest which were on Saturday presented to Thos. S. Martin, secretary of the Park Commission, were made by Simons, Bro. & Co.

The hearing of the application for the discharge of Charles H. O'Bryon and George W. Scherr, formerly trading as L. A. Scherr & Co., bankrupt jobbers, has been fixed for Dec. 15.

C. F. Rumpp & Sons, manufacturers of leather goods, donated \$50 Thanksgiving day to the German Hospital, while at the same time the Keystone Watch Case Co.

gave \$40, and Bailey, Banks & Biddle Co. \$25.

The City Council of Wilmington will, it has been stated, soon ask for bids for a new timepiece for the City Hall, the present clock having been in use nearly a century and its works being worn out.

Charles Lockhart, formerly with L. A. Scherr & Co., and who about two years ago went west for his health, has returned to this city and has entered the employ of James D. Hughes, wholesale jeweler, 723 Chestnut St.

The loving cup presented to the St. Andrew's Society by its members, at the banquet Thursday night, is a splendid example of the silversmith's art, weighing 100 ounces. It was designed and made by J. E. Caldwell & Co.

S. Lubin, manufacturing optician, who has a cineograph show at the National Export Exposition, has completed negotiations to have a series of moving pictures taken of a performance of Hagenbach's animals, and will exhibit the pictures abroad.

The charge of shoplifting jewelry from Wanamaker's store made against Alice, Irene and Ambrosine Mordecai some weeks ago, and which was exploited at the time in these columns, was withdrawn Friday

and a verdict of not guilty taken. Mayor Ashbridge made himself notorious by furnishing bail for the women and demanding their discharge. Wanamaker's detectives refused to acquiesce, making oath that the women had been caught stealing belts, buckles, bracelets and stick pins. Now the detectives state "the goods were taken by mistake and not with criminal intent."

**Cleveland.**

Wm. C. Kinney, of this city, called at Police Headquarters at Pittsburgh, Pa., last week, and identified John Robinson, who was arrested there for the attempted robbery of A. E. Siedle's jewelry store, as one of three men who robbed him of \$75 on an elevator in Cleveland a few days before the Pittsburgh robbery.

The Leonard Mfg. Co., of Chicago, expect to move to this city and have secured quarters in the Leonard block, corner Lake and Water Sts., where they will open up one of the largest mail establishments in the country. The firm comprise M. M. Levison, Henry Morris and Louis Morris, and it is their intention to make a specialty of all kinds of jewelry.

Jake Goldman, Poweshiek, Ia., has sold out.

WANT TO ROUND OUT YOUR WATCH STOCK?

IF SO,  
WRITE TODAY  
RATHER THAN  
TOMORROW.  
C.G. ALFORD & CO.  
195 BROADWAY  
NEW YORK.

WATCH US FOR WATCHES

# A Few Suggestions.

**Do you want** your stock of Sterling Silver Ware to embrace the identical articles that are sold by Dry Goods Stores? Having in mind that the latter are sending catalogues by the thousands to the homes of your own customers, is it not a fact that the illustration of the patterns in your stock in such Catalogues makes these goods undesirable for the finer class of your patrons? Is it not true that a person of taste, desiring to make a Wedding Anniversary or other complimentary gift, would hesitate to send an article generally found in Dry Goods and Department Store Catalogues?

**If these are facts,** why not confine your purchases of Silver to the Manufacturers who deal only with the legitimate Jewelry trade, thus protecting your interests and preserving the fashionable exclusiveness of the wares in your stock, so often a feature in consummating an important sale. The productions of the **Gorham Mfg. Co.** are never sold except through the best class of Jewelers.

**They are fashionable.**

**They are exclusive.**

**Their quality is unquestioned.**

**They are not higher priced.**



## Gorham Mfg. Co.,

...SILVERSMITHS...

Broadway and  
19th Street,  New York.

BRANCHES:

NEW YORK:  
21 & 23 Maiden Lane.

CHICAGO:  
131-137 Wabash Avenue.

SAN FRANCISCO:  
118-120 Sutter Street.

WORKS: PROVIDENCE, R. I., AND NEW YORK CITY.

# The Jewelers' Circular AND HOROLOGICAL REVIEW.

PUBLISHED EVERY WEDNESDAY BY  
**THE JEWELERS' CIRCULAR PUB'G CO.,**  
CORBIN BUILDING, 11 JOHN ST., COR. BROADWAY,  
NEW YORK.

TELEPHONE: 1148 CORTLANDT. CABLE ADDRESS: JEWELAR, NEW YORK.

A JOURNAL DEVOTED TO THE INTERESTS OF JEWELERS, WATCHMAKERS, SILVERSMITHS, ELECTRO-PLATE MANUFACTURERS, AND ALL ENGAGED IN KINDRED BRANCHES OF INDUSTRY.

Member of the American Trade Press Association.

Our editorial columns will contain our own opinions only, and we shall present in other columns only what we consider of interest or value to our readers. Advertising matter will not be printed as news.

Advertising rates in THE CIRCULAR are lower, considering the number of tradesmen reached by its large circulation, than in any other jewelry journal.

Notices of changes in standing advertisements must be received one week in advance; new matter can be received up to Monday.

### INFORMATION FOR SUBSCRIBERS.

#### Terms of Subscription, Postage Prepaid.

	PER ANNUM.
United States and Canada, - - -	\$2.00
Foreign Countries in Postal Union, - - -	4.00
Single Copies, - - - - -	.10

New Subscribers can commence at any time.

Payments for THE CIRCULAR, when sent by mail, should be made in a Post-Office Money Order, Bank Check or Draft, or an Express Money Order or Registered Letter. All postmasters are required to register letters whenever requested to do so.

Pay money only to authorized collectors having proper credentials.

**Returning Copies.** Returning your paper will not enable us to discontinue it, as we cannot find your name on our books unless your address is given.

**Changing Address.** In changing address always give the old as well as the new one. Your name cannot be found on our books unless this is done.

**Discontinuances.** We will continue to send papers until there is a specific order to stop, in connection with which all arrearages must be paid; but such an order can be given at any time, to take effect at or after the expiration of the subscription. All such orders will be promptly acknowledged by mail.

**Liability.** The courts have decided that all subscribers to journals are responsible until arrearages are paid in full and an order to discontinue has been received by the publisher.

#### THE JEWELERS' CIRCULAR IN EUROPE.

Among the places in Europe where THE JEWELERS' CIRCULAR is on file are the following:

- LONDON—First Ave. Hotel, Holborn, E. C.; Holborn Viaduct Hotel, Royal Hotel.
- PARIS—Hotel de L'Athene, Rue Scribe.
- LEIPZIG—Handels-Zeitung, fur die gesamte Uhren-Industrie.
- BERLIN—Deutsche Uhrmacher Zeitung, Jager-Strasse, 73.
- GENEVA—Journal Suisse D'Horlogerie.
- AMSTERDAM—Continental Club, Hotel Amstel.
- ANTWERP—Diamond Club, Rue de Pelican.

Vol. XXXIX. Dec. 6, 1899. No. 19.

Every line of reading matter in THE JEWELERS' CIRCULAR, with the exception of the few brief extracts from exchanges, always properly credited, is written exclusively for this journal. Each issue of THE JEWELERS' CIRCULAR is copyrighted. Permission to quote is extended to other publications provided such quotations are properly credited.

THE approaching holidays, with the increased displays of rich jewels and the gathering about the shops of crowds of sightseers and buyers, have aroused the energies of the enterprising robber, and he is abroad in the land in large numbers. The jeweler cannot exercise too much vigilance in his dealings with presumptive customers, and he should be alive to all suggestions aimed to minimize the chance of loss to jewelers through clever members of the light fingered fraternity. In the article entitled "Immunity Against Thieves," in another portion of this issue of THE CIRCULAR, are several rules. These rules may strike the jeweler as axiomatic or obvious; but the failure to exercise them, nevertheless, has, the experiences of the police prove well, been followed by many a serious loss to the jeweler.

#### Precious Stone Imports During November.

THE importations of precious stones through the Port of New York

during the November just passed maintain the high record of the previous months. The report of Gen. Geo. W. Mindil, Jeweler Examiner at the Appraiser's stores, for November, 1899, is as follows:

	Cut.	Rough.
Precious stones ...	\$811,625.13	\$264,774.51
The same month of the three preceding years shows:		
	Cut.	Rough.
1898 .....	\$427,334.09	\$445,655.04
1897 .....	640,668.52	230,256.02
1896 .....	116,982.10	114,946.48

For the 11 months ended Nov. 30, 1899, the importations of precious stones amounted to nearly \$19,000,000, of which over \$13,000,000 worth was cut and over \$5,600,000 was rough.

#### American Competitive Methods Approved.

THE London Watchmaker, Jeweller and Silver-smith for November

reports an interesting interview with C. M. Fogg, connected with one of the large watch case companies of the United States. Among Mr. Fogg's impressions of his trip to Great Britain and the Continent are the following: "London is undoubtedly one of the greatest distributing points in the world for watches, whilst the increased popularity and the confidence which the English trade places in American watches is decidedly marked. The fact that English watch dealers have been so ready to recognize the merits of the American watches manufactured by machinery on the best scientific principles, in spite of the fact that England has for hundreds of years had a world-wide reputation as manufacturers of good watches, shows that fairmindedness for which Englishmen are celebrated the world over. After Great Britain, Germany presents the next best field for high grade American watches. It is quite conspicuous that the more the English language is spoken the more marked is the appreciation of the people for good timekeeping watches." Apropos of these remarks, THE CIRCULAR's London correspondent notes that in common talk in trade circles American competition is regarded with a different feeling to that of other countries. The

German and Swiss imports, for example, are looked upon very differently. The case now before the courts, referring to "English Levers," arouses indignation, on the ground that (if the allegations are true) the Swiss movements are being sold under the cloak of the English Hall-mark. The average Englishman rather appreciates open and above-board competition, as it puts him on his mettle; but he is intensely aggravated at being "taken in." It is then that "foreign rubbish" is talked about. In the course of the last year or two THE CIRCULAR correspondent quoted has been in communication with many English manufacturers, avowedly as representing THE CIRCULAR, and only upon one occasion has he heard complaints of American competitive methods.

#### End of the Peabody Case.

##### Certain Goods Released Outright and a Fine Imposed on Others.

In accordance with his decision which he sent to Washington last week, and which was fully outlined in the last issue of THE CIRCULAR, Collector Bidwell, of the Port of New York, Monday returned to Adolph Peabody the diamonds and precious stones which have been for the past few weeks under detention pending an investigation on the charge of their having been smuggled. The amount of the entire lot was about \$15,000, and of this the greater part consisted of diamonds of over half a karat, which Mr. Peabody proved to the satisfaction of the Collector were cut in this country. These stones have been returned to him outright. The remainder of the lot, consisting of precious stones and melée, valued at \$4,416.10, the Collector agreed to return upon payment of a fine equal to the amount of the duty which should have been paid. This fine, amounting to \$441.61, was paid by Mr. Peabody and the stones released to him.

In speaking of the case yesterday to a CIRCULAR reporter, Ex-Judge Dittenhofer, counsel for Mr. Peabody, called attention to the fact that this could not be considered as a smuggling case in any way. The utmost that could be claimed, he said, was that Peabody, having purchased stones in this country, some of which had been cut here and others on which duty had already been paid, took them out of the country and reimported them without extra payment. While there might be a technical violation of the Customs law in regard to a few of the goods, there was no contention that Mr. Peabody intended to defraud the Government in any way. Another hard part of the case, from Mr. Peabody's standpoint, is the fact that in paying the \$441 he paid duty upon certain diamonds as imported goods which were purchased by him from dealers in this country on the representation that they were cut here.

J. E. Jahnke, optician, Chattanooga, Tenn., whose serious illness was reported some days ago, is much worse, and it is hardly expected that he will live. His brother has arrived from Richmond, and everything possible is being done for him. Meningitis has taken a firm hold upon him and the physicians express little hope.

## Trade-Mark Information.

Note.—The publication of our work, "Trade-Marks of the Jewelry and Kindred Trades," containing over 2,250 marks, all told, the accumulation of various works of reference and the ramifications of our business enable us to trace to their origin nearly all marks that may be found on jewelry, silver ware, art pottery and kindred lines, of both American and foreign make. All questions in regard to trade-marks will be cheerfully answered. We would be pleased to have the trade seek the benefit of our facilities regarding the identity of any marks they cannot trace. We would prefer to receive the article for examination; for if the mark is of foreign origin, the slightest difference between a drawing and the original is of great importance.

No question is too trivial nor too complicated for consideration under this department.

CHICAGO, Nov. 18, 1899.

Editor of THE JEWELERS' CIRCULAR:

Regarding the watch case referred to on



page 48 of the Sept. 6 issue of THE CIRCULAR will say as follows regarding the Ross

guarantee. This was an invention of a man named Jackson, at that time manager for Lamos & Co., of this city. Jackson would sell a lot of fake cases to a customer and give him as many guarantees, in a separate bundle, as he had sold him cases. No matter what make the cases were, the customer would himself put the guarantees in the cases. Mr. Jackson was, by fear of being prosecuted by the Keystone Watch Case Co., forced to desist from this practice. After Lamos's death, Jackson was manager for Mrs. Lamos, and, when the estate was settled up, Jackson continued the business for himself in a smaller way, later failed in business, and disappeared from sight some four years ago.

Respectfully yours,

P. S.

MARQUETTE, Mich., Nov. 29, 1899.

Editor of THE JEWELERS' CIRCULAR:

We send you this mail two teaspoons. We are unable to find who makes them, as we cannot find the marks in your book of "Trade-Marks." Will you kindly inform us who makes them?

Yours truly, GEO. N. CONKLIN.

ANSWER:—The spoon stamped as below



STERLING

is made by Watson & Newell Co., Attleboro, Mass. See page 4. "Supplement, Trade-Marks of the Jewelry and Kindred



STERLING

Trades." The spoon stamped as above is

made by F. S. Gilbert, North Attleboro, Mass. This house has only recently gone into the manufacture of some kinds of spoons; hence the omission of its trade-mark from our book or supplement.

ELYRIA, O., Nov. 27, 1899.

Editor of THE JEWELERS' CIRCULAR:

We are sending you under same cover a sterling teaspoon, trade-mark on which I am unable to find in your "Trade-Marks." Thanking you in advance for your early reply. I am,

Very respectfully,

E. E. CRITZ.

ANSWER:—This spoon was made by the old firm of Jos. Seymour, Sons & Co., Syracuse, N. Y., whose business now is conducted by the Jos. Seymour Mfg. Co., 36 Montgomery St., Syracuse, N. Y. The trade-mark stamped on the spoon, as below, is their old and discontinued one;



the present one being

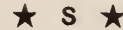

## Trans-Atlantic Voyagers.

TO EUROPE.

E. Sussfeld, of Sussfeld, Lorsch & Co., New York, sailed Saturday on the *Campania*.

D. De Sola Mendes, New York, and F. A. Jeanne, of Alfred H. Smith & Co., New York, returned last week on the *Umbria*.

FROM EUROPE.

Adolphe Paroutaud, New York agent of J. Pouyat, Limoges, France, returned last week on *La Champagne*.

## H. E. Wiederrecht Accused of Running a "Fence."

DENVER, Col., Nov. 28.—H. E. Wiederrecht, jeweler, 1724 Larimer St., has been arrested on the charge of receiving stolen goods. He turned up about \$100 worth of jewelry and silver ware that had been sold to him by George Washington, a colored thief. He had hidden the stuff in his shop and at first denied that he had it at all. Two watches that were sold to him a few days ago had been melted up. He had also taken two small diamonds from a pair of bracelets. The police say that Wiederrecht has been running a "fence" for thieves for several years, and that they will send him to the penitentiary for a long term of years.

The demand for the "Marcella" neck and guard chains since they were first put upon the market has been phenomenal, and they are proving to be among the best selling goods for the holiday season. Jewelers desiring to advertise these chains in their local papers can procure electrotypes free of charge by applying to Lissauer & Co., P. O. Box 2516, New York, and mentioning THE JEWELERS' CIRCULAR.

# ON MEMORANDUM



You'll have all kinds of stockings to cater to in the next few weeks, and nowhere will you get such an assortment of Diamonds and Diamond Jewelry as we can send you; but they won't last long in view of the rising market. Don't forget that our goods were bought months ago, and, notwithstanding the rises, will be sold at nearly the old prices, while they last. Anything you want—loose or mounted—"On Memo."

V. WARING, N.Y.

# CROSS & BEGUELIN

Importers and Cutters of Diamonds and Precious Stones

43 Rue de Meslay, PARIS

17 Maiden Lane, NEW YORK

**New York Notes.**

Secretary De Loid Safford, of the Jewelers' Association and Board of Trade, returned from his trip to Savannah, Ga., Thursday, much improved in health.

Judge Hascall, of the City Court, Saturday appointed Frank M. Holahan receiver for Angela M. Devlin in supplementary proceedings instituted by the Bartens & Rice Co. as judgment creditors.

The first meeting of the creditors of Isaac Steinau, who filed a petition in bankruptcy Nov. 23, has been called for Dec. 11, at 2 o'clock P. M., at the office of F. K. Pendleton, referee in bankruptcy, 44 Broadway.

Creditors of John Mason, a former jeweler, now in bankruptcy, are notified that a hearing on his petition to be discharged of all his debts will be had in the United States District Court, Dec. 13, at 10.30 o'clock A. M.

E. E. Kipling, a former dealer in precious stones, who filed a petition in bankruptcy April 22, was recently discharged of all his debts by Judge Kirkpatrick, in the United States District Court, in New Jersey.

James and Morris Klaber, of S. Klaber & Co., sons of the late Simon Klaber, the former head of the firm, announce that the marble working business conducted at 47 W. 42d St. will be continued by them as before, under the old firm name.

The Barker Silver Co., of New York city, have been incorporated with a capital of \$50,000. Charles B. Barker and James N. Blauvelt, Brooklyn, and Charles E. Barker, J. W. Bird and R. L. Tarbox, of New York, are the directors of the company.

The reports published in the daily papers last week to the effect that the police of the W. 30th St. Station were investigating a robbery from Bartens & Rice Co., jewelers, 328 Fifth Ave., have been pronounced untrue both by the police and the jewelry firm. The alleged thefts were reported as amounting to \$6,000.

Postmaster-General Smith sent Postmaster Wanser, of Jersey City, last week, a fraud order against James McAndrew, of 92 W. 49th St., Bayonne. The order prevents him from receiving any mail matter or using the mails. McAndrew, as told in THE CIRCULAR last week, was arrested on a charge of conducting a green goods business under the cloak of selling imitation jewelry.

The Brooklyn police are looking for the thieves who about 6 o'clock Saturday morning robbed the store of Abraham

Nathan, Manhattan Ave. and Kent St., of jewelry valued at \$150. A brick was hurled at the window, completely shattering the plate glass, which measured 10 by 10 feet. A number of trinkets, valued at the amount stated, were then removed from the showcases in the store.

The Merchants' Association of New York have set on foot an investigation of all matters pertaining to the proposed Ramapo water contract, and at the request of this body the Board of Public Improvements, on Nov. 22, passed a resolution suspending all action on the Ramapo contract for three months to permit the association to make a thorough inquiry into all the circumstances bearing upon the matter.

Tiffany & Co. have denounced as unauthorized and absolutely untrue the various reports published in the newspapers of the country associating their name with the management of the North American Turquoise Syndicate, recently incorporated. Tiffany & Co. say that they have had absolutely nothing to do with this concern and decidedly object to the use of their name in connection with it.

Isaac Kutner, who claimed that he was employed as a collector by a New York jewelry firm, was arrested at New Rochelle last week on a charge of larceny. He was accused of stealing from Miss Helen Gabriel an engagement ring valued at \$55, given to her by Chas. Brown. Kutner claimed that the ring had not been paid for by Brown, and that the latter had authorized him to take it back. He ob-

tained it from Miss Gabriel by a subterfuge, and when he attempted to depart with it she had him arrested.

Tiffany & Co. have commenced an action in Chicago to recover \$4,500 on a



**The Public Approves...**

We know from the way our Holiday styles are selling that they have met with a full measure of approval.

**Waterman's Ideal Fountain Pen**

will be the most profitable specialty of the season if you carry a full stock and give the goods a chance.

**L. E. Waterman Co.,**  
155-157 Broadway, New York.

Largest Manufacturers of Fountain Pens in the World.

While we cannot take any more orders to be made up before January 1st, we have a large and varied stock of CUT GLASS in New York for prompt shipment.

**C. Dorflinger & Sons,**

36 MURRAY STREET, NEW YORK.

1851.

1899.

**THE CHATHAM NATIONAL BANK, NEW YORK.**

CAPITAL STOCK, - - - \$450,000  
UNDIVIDED PROFITS, - - - 974,518

H. P. DOREMUS, Cashier.

GEO. M. HARD, President.

W. H. STRAWN, Ass't Cashier.

**EGYPTIAN SCARABS,**

MOUNTED AS FOBS, CHARMS AND SLEEVE LINKS.

**GEO. O. STREET & SONS,**

24 JOHN ST., NEW YORK.

... Established 1837 ...



**EMPIRE COMBS. SIDE COMBS.**

GOLD AND JEWELLED ORNAMENTED.

**SPECIALTIES IN ROMAN WORK.**

**DAY, CLARK & Co.,**

MAKERS OF FINE JEWELRY,

23 MAIDEN LANE, N. Y.

**WM. SMITH & CO.,** GILL BLDG., 9-13 MAIDEN LANE, N.Y.  
61 PECK ST., PROVIDENCE, R. I.

ESTABLISHED 1854

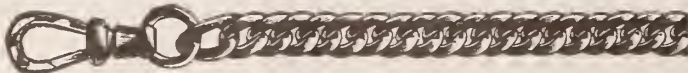

MANUFACTURERS OF

**Gold, Silver and Rolled Plate Chains and Jewelry.**

Novelties in Gold and Silver Bracelets. Also a large line of Chain Trimmings.

**ALOIS KOHN & CO.,** 4 MAIDEN LANE, SOLID GOLD CHAINS,  
Near Broadway, N. Y.

We call the attention of the Trade throughout the country to our line of

**LORGNETTE AND GUARD CHAINS.**

Will send Samples on Memorandum on receipt of satisfactory reference. Correspondence Solicited.

**BONNER & CO.,**

Manufacturers of

**FINE DIAMOND MOUNTINGS,**

57 MAIDEN LANE, NEW YORK.



SAMPLE OF ENGRAVING DONE ON THE

**Eaton-Engle Engraving Machine.**

CATALOGUE AND SAMPLE OF WORK FREE.

**EATON & GLOVER** have removed to the FULTON BUILDING,  
87 NASSAU ST., Cor. Fulton, N. Y.

BUY

**"Simmons" CHAINS**

R. F. SIMMONS & CO.  
ATTLEBORO, MASS.  
N. Y. 9-13 MAIDEN LANE.

THEY SELL!



**THE MAUSER MFG. COMPANY,**  
SILVERSMITHS,

"Watch Our Ads." 15th St., bet. Broadway and Fifth Ave., New York.

jewelry account owed them by the late Alice Snell McCrea, who died about a year ago. The suit is brought against the executors of the estate of the deceased, who was a daughter of a millionaire of Chicago. The debt was secured on a trust deed on some lots, and the plaintiffs declare that neither taxes have been paid on the property nor interest paid on the note to them, so that the entire amount due is about \$7,000. Tiffany & Co. asked the Court to compel the executors of the deceased to pay them that amount.

H. M. Condit, former secretary of the New York Jewelers' Board of Trade, has the sympathy of his friends in the Lane over the death of his mother, which occurred last week.

The creditors of Henry Carter, under his old assignment to F. L. Zabriski, are notified to appear before L. J. Benson, the referee appointed to take and state the accounts of the assignee. The hearing for this purpose will take place at the referee's office, 56 Wall St., on Dec. 21, at 4 o'clock P. M.

The bail in the case of Francois Bock, who, as told in THE CIRCULAR last week, was indicted on a charge of attempting to smuggle nearly 1,000,000 imitation pearls, will probably be reduced. It was originally placed at \$5,000 by Commissioner Shields, but after a conference between the prisoner's attorney, Samuel Greenbaum, and Assistant United States District Attorney Baldwin, the latter agreed to have it reduced to half that sum, or to \$2,500. Yesterday Commissioner Shields reduced the bail to \$3,000, and Bock was released on the bond of Alexander Rollins.

Isidor Heyse, a watchmaker, who has an office on the second floor of 70 Fifth Ave., was alone in his shop when a stranger entered about 11 o'clock, Friday morning. The man asked for a clock which had been left by a Mr. Davis, who, he said, was a buyer for R. H. Macy & Co., and when Mr. Heyse told him he had no such clock, the stranger remarked that he would wait for a few minutes, as he expected Mr. Davis in to straighten out the matter. Mr. Heyse thereupon turned his back and resumed his work, but in a few minutes noticed the stranger suddenly grab a watch and run out of the place. Mr. Heyse pursued him, and in so doing tripped upon the long stairway into the street, and by his fall received serious injuries about the head. The thief escaped. Mr. Heyse had his wounds dressed and then notified the police.

The body of John Daniel Brez, who, as told in THE CIRCULAR, Nov. 22, died at Clarens, Switzerland, Nov. 18, was brought to this country and the funeral services will be held to-day at his late residence, 22 Pierrepont St., Brooklyn, at 3 o'clock P. M. The interment will take place at Greenwood Cemetery. The deceased was the son of Paul A. Brez, who for about a

half a century was a leading watch importer of New York. Upon the death of the elder Brez, on May 1, 1878, John Daniel Brez closed out the watch business and became a broker. His death occurred while on a visit to his sister, Mrs. Gillet, in Switzerland.

John Drake, the New York representative of R. F. Simmons & Co., and Miss Jennie Farrington, of Brooklyn, were married yesterday afternoon. Mr. Drake is one of the youngest and most popular New York salesmen of the eastern houses, and has the well wishes for his future happiness of his many friends throughout the trade.

The Appellate Term of the Supreme Court last week affirmed the decision of the Municipal Court, in favor of the defendant, in the action brought by James A. Flomerfelt against Herman Englander. Flomerfelt sued to recover rent under a lease made to Englander, March 29, which the latter contended was never completed or accepted by him. The Court upheld this contention.

The work in preparation of the coming banquet of the Jewelers' Association and Board of Trade, which, as exclusively told in THE CIRCULAR last week, will be held Jan. 23, 1900, at the Hotel Waldorf-Astoria, is already well under way by the various committees in charge. The banquet committee, of which Oliver G. Fessenden is chairman, met Wednesday last and formally commenced their work, appointing sub-committees on wines, etc., while the printing committee, of which Leo Wormser is chairman, met Saturday. The speakers committee, in charge of Ludwig Nissen as chairman, met Monday afternoon and decided on some of the speakers whom

they wish to obtain, detailing individual members to get the consent of these speakers. The members of the general committee have shown unusual activity and have taken up their work with a will. The committee on printing and souvenirs will, within a short time, have their notifications of the banquet out to the members, asking them to decide as quickly as possible how many tickets they will desire.

**Trade Gossip.**

At a time such as this when retailers and jobbers are having difficulty in obtaining all the watch movements they desire, jewelers generally will be interested in knowing where large assortments of ladies' and gentlemen's watches may always be had. It is therefore timely to remark that John W. Sherwood & Co., the well known jobbers, 3 Maiden Lane, New York, have on hand always a large stock of movements, especially of Dueber-Hampden watches, of which they are said to be the largest distributors in New York.

At this season of the year, Jacot & Son, importers and manufacturers of music boxes, 39 Union Square, New York, are calling attention to the number of musical novelties especially suitable as Christmas presents, which they carry in addition to the regular music box line. Among these are musical albums, musical beer mugs and musical decanters. All, especially the beer mugs, decanters and albums, are made in the ordinary form of the article, with a hidden musical movement. The decanter and the beer mug, which have a music box at the bottom, start playing the moment the article is raised, while the album plays upon being opened. The regular lines of

music boxes made by this firm are so well known that comment upon them would be superfluous.

The demand for fine and complicated watches, as is well known, has been this season larger than for many years back, and while the condition is partly due to the general prosperity, it is in great measure also owing to the improvements in the manufacture and design that have been made in the fine Swiss watches of recent years. This is especially true of the product of Mathey Bros., Mathez & Co., 21-23 Maiden Lane, New York, whose chronographs, splits and repeaters are renowned throughout the entire trade. It may be said of this firm's watches that the improvements within the recent years have been so pronounced that it is almost impossible to compare their watches of years ago with their watches of to-day. Heretofore the complicated watches had two pronounced disadvantages; first, their large size as compared with the ordinary watch; and second, the difficulty and expense in repairing. These disadvantages have been entirely eliminated by the firm above named, as will be seen from an inspection of the lines now displayed at their offices. Their splits, chronographs and repeaters are not only made as small and as thin as any ordinary watch, but the parts of these watches are now made on a uniform principle, are interchangeable, and can be purchased from the manufacturers at a very low cost. These improvements in the manufacture of fine watches have not come all at once, but have been gradually developing through years of experimenting at the factory, under the supervision of Charles H. Meylan. Their splits and chronographs follow the regular watch sizes, from 12 to 16, while their repeating watches run from the smallest ladies' size up. The assortment which this firm always carry on hand is one of the largest to be found in the metropolis.

**HOLIDAY SELLERS—ORDER EARLY.**



No. 65, Gents' Set. Pair Sterling Mounted Ebonoid Military Brushes and Sterling Top Comb, \$2.12, complete. Illustration one-half size. Foxwood Brushes, "New," same price. Real Ebony Brushes, \$2.63 pair.



No. 67, Gents' Set, for traveling. Real Leather Case, with pair of Ebonoid Sterling Shield Brushes, \$2.00, complete. Pair Brushes only, \$1.50. A Big Seller. Foxwood Brushes, "New," same price. Real Ebony Brushes, \$2.50, complete.

Prices net less 8% for Cash. Consult Catalogue for other Sellers.

**AVERBECK & AVERBECK, Manufacturers,**

**19 Maiden Lane, New York.**



Traveling representatives may consider these columns open for the publication of any news or items of interest regarding themselves or their confreres.

Traveling representatives seen in Indianapolis, Ind., last week were: A. R. Varian, Dennison Mfg. Co.; Roman Warshawski, for I. Ollendorff.

Traveling men were not numerous in Louisville, Ky., last week. Those there were: W. J. Lemoin, Ames-Bonner Co., Toledo, O.; Sol K. Jonas, for I. W. Friedman, New York; Leo Goldsmith, New York; I. B. Ettinger, Gattle, Ettinger & Hammel, New York; Ed. J. Mayer, Julius King Optical Co.; Chas. B. Burgess, Frank M. Whiting & Co., North Attleboro, Mass.; A. F. Elliott, W. J. Braitsch & Co., Providence, R. I.; Max Arnstein, Arnstein

### CONSULT

## "The New York Jeweler"

Before Buying Jewelry or Kindred Lines.

For 26 years the acknowledged authority for all that is new, artistic and beautiful in the Jewelry World.



An idea of the assortments illustrated is shown by the fact that there are over 1000 Designs in **Diamond Jewelry**; 2000 Designs in **Watches**; 3000 Designs in **Emblems**; 5000 Designs in **Gold and Silver Novelties**; and proportionate displays from our **Silverware, Clock, Cut Glass, Lump, Musical, Photographic, Optical, Scientific Instruments, Leather and Fine Stationery** Departments.

724 Pages. Size, 9x13.

This profusely illustrated catalogue enables the dealer to make a better selection than the majority of travelers' stocks affords.

## S. F. MYERS CO.,

MANUFACTURING and WHOLESALE JEWELERS

Myers Building, 48-50 Maiden Lane, New York.

Mention Dept. G 12 when sending for catalogue.

Bros. & Co., New York; Mr. Hofer, M. A. Mead & Co., Chicago.

Edwin Giles has taken a position on the road for C. K. Landon, Chicago.

Max Noel, Stein & Ellbogen Co., Chicago, visited the house for a few days last week.

Mr. Zuggerberg, of the L. Seligman Jewelry Co., New York, was in Chicago last week.

Mr. Matthews, formerly a traveler for H. L. Houghton, Boston, Mass., has taken a position with F. S. Hall, Fitchburg, Mass.

Ed. Hoffman, F. C. Happel Co., Chicago, rushed in last week to get a new assortment and immediately struck out for the west again.

Tom Hofer, M. A. Mead & Co., called at the Chicago house for a single day last week and seemed to regret being off the road that long.

All of the travelers of H. F. Hahn & Co., Chicago, had the pleasure of returning for a Thanksgiving dinner at home, leaving for their territories the following day.

Among traveling representatives in Toronto, Ont., last week were: F. M. Lahm, Edward Todd & Co.; J. M. Armbruster, Illinois Watch Co., and C. H. Greene, Simpson, Hall, Miller & Co.

Among the travelers in Kansas City, Mo., last week were: Chas. Lochner, Hayes Bros.; Herman Kind, Graef & Schmidt; Otto Sinauer, Oppenheimer Bros. & Veith; Lawrence H. Smith, Bip-part & Co.

Eastern jobbers and manufacturers represented in the Twin Cities the past week were: Riley, French & Heffron, by Ray Randall; Herman & Co., by Mr. Mann; Goodfriend Bros., by Mr. Engelsmann; F. C. Happel Co., by Mr. Happel.

The jewelers of Portland, Ore., were interviewed the past week by the following traveling men: David Beer, Bernheim, Cohen & Beer, New York; Jacob Marx, Kossuth Marx Jewelry Co., New York; W. H. Thompson, H. A. Kirby Co., New York; Burr W. Freer, Heacock & Freer, San Francisco, Cal.; A. J. Lyons, George Greenzweig & Co., San Francisco.

Traveling men in Boston, Mass., the past week included: E. A. Woodmaney, Potter & Buffinton; H. W. Dunham and H. B. Beach, International Silver Co.; Mr. Sansbury, Sansbury & Ellis; Ed. Eckfeldt, Eckfeldt & Ackley; Mr. Crane, Strobell & Crane; J. Leonard Snow, Snow & Westcott; John A. Abel, David Kaiser & Co.; Mr. Jones, C. A. Marsh & Co.; Mr. Cole, Towle Mfg. Co.; E. W. Martin, Martin, Copeland & Co.

The following traveling salesmen passed through Detroit, Mich., last week: Mr. Gregory, Strobell & Crane; R. H. Schley, Sloan & Co.; T. E. Browne, E. Ira Richards & Co.; Robert P. Sutcliffe, Geneva Optical Co.; W. S. Dudley, Rogers, Smith & Co.; G. W. Bleecker, Martin, Copeland & Co.; W. H. Bryant, T. G. Hawkes & Co.; George Frey, Ford & Carpenter; Mr. Parker, Osmun-Parker Mfg. Co.; W. H. Hamill, Leys, Christie & Co.; W. E. Bliss, E. A. Bliss Co.; S. H. Joseph, Eliassof Bros. & Co.; T. J. Hofer, M. A. Mead & Co.; S. Cohn, Oppenheimer Bros. & Veith.

Among the travelers in Syracuse, N. Y., the past week were: M. M. Corsa, Dominick & Haff; L. Weber, Joseph H. Fink & Co.; Walter S. Noon, W. F. Cory & Bro.; Otto J. Somers, for I. Ollendorff; M. Klipper, Hipp. Disidheim & Bro.; Mr. Kenrick, Reed & Barton; J. C. Cook, Bergstein & Son; Edward R. Kant, Green Bros.; M. Stratton, Jr., Alling & Co.; F. M. Lahm, Edward Todd & Co.; Edward S. Watkins, William Wise & Sons; Mr. Sutherland, for E. C. Keer; E. W. Dellar, William S. Hicks' Sons; H. D. Brown, Paul Mfg. Co.; Frank E. Whitmarsh, Alvin Mfg. Co.; Mr. Marston, Manning, Bowman & Co. Alfred H. Smith & Co. were also represented.

Travelers in St. Louis, Mo., last week were: J. C. Howard, Dominick & Haff; Mr. Jonas, for I. W. Friedman; F. R. Krugler, the H. A. Kirby Co.; Frank F. Gibson, for Wm. Kinscherf; F. R. Horton, Carter, Hastings & Howe; H. A. Bliss,

Kremenz & Co.; C. L. Krugler, Jr., Champenois & Co.; H. J. Fink, for David Marx; T. H. B. Davis, International Silver Co.; E. A. Reed, Reed & Barton; M. W. Smith, S. B. Champlin Co.; Henry H. Jacobson, Jacobson Bros.; A. J. Elliott, W. J. Braitsch & Co.; Thomas E. Rogers, Riker Bros.; H. C. Rowbotham, C. P. Goldsmith & Co.; Herman Kind, Graef & Schmidt; F. D. Smith, N. E. Whiteside & Co.; Charles B. Burgess, Frank M. Whiting & Co.; Chas. Williams, Gorham Mfg. Co.; L. E. Smith, M. B. Bryant & Co.

The list of travelers for eastern firms in Pittsburgh, Pa., last week is unusually small, and the postal cards received as notices of those to arrive this week were very scant in number. Among the few in the city last week were: Mr. Bleecker, Wm. S. Hedges & Co.; A. Adler, New Jersey Lamp and Bronze Works; H. A. Bliss, Kremenz & Co.; J. W. McClannin, International Silver Co.; Herbert W. Van Houten, for C. Sydney Smith; Frank E. Whitmarsh, Alvin Mfg. Co.; W. H. Gregory, Strobell & Crane; Harry Osborne, R. Wallace & Sons Mfg. Co.; E. A. Brannon, Jno. W. Reddall & Co.; J. Fred Crane, Mandeville, Carrow & Crane; Walter S. Strauss, Jacob Strauss & Sons; Fred Clarkson, Albert Lorsch & Co.; Max S. Jacoby, Manchester Mfg. Co.; Mr. Metcalf, R. Blackinton & Co.

### Boston.

E. H. Harnden, formerly for many years with the American Waltham Watch Co., is now with D. C. Percival & Co. as inside salesman.

Bernard Addleberg, jeweler, 1023 Washington St., notified the police Friday that S. Ellisberg, his salesman, was missing, and from his safe there had been taken in his absence five silver watches, four gold watches, two diamond rings and other jewelry. He believes the clerk and the goods have disappeared together and the police are looking for the man.

Benjamin Ellis, for many years a well known Boston optician, located at 120 Tremont St., received last Wednesday from the German Government a bronze medal commemorative of the 100th anniversary of the birth of William I., of Germany. The metal is from a bronze cannon captured from the French in the war of 1870. Mr. Ellis was a soldier in the Prussian army and has other medals awarded him for bravery in battle.

Robert Phillips, charged with the larceny of a diamond ring from Eben Cain, jeweler, Summer St., has been held in \$500 for the Grand Jury. It is alleged that Phillips visited Frank Moakley, an employe of Cain, and while in the place was shown the diamond ring. Subsequently it was missing, and circumstances, according to Moakley's testimony, indicated that Phillips took it. Phillips, on the other hand, tried to throw suspicion on Moakley, but the Judge found probable cause to hold the accused as above.

W. Scott is continuing the business of S. & W. Scott, Floyd, Va.

# The Mercantile National Bank

OF THE CITY OF NEW YORK,

BROADWAY AND DEY STREET,

Solicits Accounts from the Jewelry Trade.



**Special Notices.**

**Situations Wanted.**

**YOUNG MAN**, 7 years' experience, desires to obtain position in a wholesale jewelry firm. Address M. C., care Jewelers' Circular.

**WATCHMAKER**, jeweler and optician would like permanent position; first-class references. Address C. G., care Jewelers' Circular.

**WATCHMAKER**—Expert on fine work would like to exchange his position; satisfactory reasons given. Address "Escapement," care Jewelers' Circular.

**WANTED**—Position as assistant watchmaker and French clock repairer, also act as salesman; first-class references. W. J., 99 Central St., Springfield, Mass.

**SALESMAN**, hustler, established trade for N. Y., Pa. and N. E., wants a manufacturer's line, 10k. or 14k. goods, Jan. 1; salary only. Address A. L. P., care Jewelers' Circular.

**GOOD WATCHMAKER** wants steady position; can do hard soldering and jewelry repairing; young man, age 24, single; wages expected \$11. Address Box 77, Franklin, Pa.

**PRACTICAL DESIGNER**, with 15 years' experience in all branches of sterling silver ware, desires position; A1 references furnished. Address "Sterling," care Jewelers' Circular.

**WANTED**—By young man, a position as traveling salesman; 12 years' experience on the road; southern territory; can give best of references. Address E. care Jewelers' Circular.

**WANTED**—A position to travel in Southern States for good house; been in jewelry business 20 years; fair salary or on commission; best reference. J. M. Nisanska, Laurens, S. C.

**SUPERINTENDENT AND DESIGNER** with large experience in all branches of sterling silver ware desires position; best of references. Address "Designer," care Jewelers' Circular.

**EXPERIENCED JEWELRY SALESMAN**, past 10 years with a jewelry and material house, is open for an engagement Jan. 1; best of references. Address R., care Jewelers' Circular.

**EXPERIENCED TRAVELER** desirous of making change, thoroughly versed in loose and mounted diamond line, wishes position with first-class house. Address "Experience," care Jewelers' Circular.

**EXPERIENCED TRAVELER** desires position from Jan. 1; well acquainted with the retail trade east and west; understands diamonds, colored goods, loose or mounted; watches, jewelry or silver ware; best of references. Address A. J., care Jewelers' Circular.

**AI OPTICIAN**, watchmaker and engraver wants a steady position with a good firm; understands the business thoroughly; young man, single, sober and steady; have tools and trial case; state salary in first letter; A1 references. Address "Optician," care Jewelers' Circular.

**Help Wanted.**

**WANTED**—Watchmaker; young, single man preferred; permanent job. F. E. Hull, Saranac Lake, N. Y.

**WANTED**—An experienced designer on sterling silver hollow ware and novelties. Address "Silversmith," care Jewelers' Circular.

**WANTED**—A young man thoroughly acquainted with the retail trade in city and surrounding in the watch line. Address, with full particulars, A. C., care Jewelers' Circular.

**WANTED AT ONCE**, in an Ohio city of 35,000 population, a young man who is a fairly good engraver and watch repairer. Address C. B. G., care Jewelers' Circular.

**WANTED**—Two first-class manufacturing jewelers and stone setters; one first-class engraver and jeweler; references required. Geo. Wettstein, manufacturing jeweler, Cedar Rapids, Iowa.

**WANTED**—An experienced traveler for the Eastern, Middle and Southern States to sell a general line of watches, diamonds and jewelry. R., L. & M. Friedlander, 30 Maiden Lane, New York.

**WANTED**—A first-class optician, watchmaker and engraver; none other need apply; state wages desired in first letter; a permanent position guaranteed to right man. Address B., care Jewelers' Circular.

**WANTED**—First-class salesman for jobbing house; one with trade in west and north-west preferred; good salary and steady position to right man. Address, with full particulars, "Jobber," care Jewelers' Circular.

**INDEX TO ADVERTISEMENTS.**

Aikin, Lambert & Co..... 51  
 Aikin, Lambert Jewelry Co..... 51  
 Alford, C. G., & Co..... 25  
 American Watch Case Co..... 51  
 American Waltham Watch Co..... 13  
 Arnstein Bros. & Co..... 52  
 Averbeck & Averbeck..... 31  
 Avery & Brown..... 34  
 Ball, Wm. H., & Co..... 50  
 Bassett Jewelry Co..... 51  
 Bell Watch Case Co..... 22  
 Billings, Chester, & Son..... 15  
 Bonner & Co..... 30  
 Bowden, J. B., & Co..... 14  
 Bradley Polytechnic Institute..... 52  
 Bradley & Hubbard Co..... 48  
 Bryant, M. B., & Co..... 50  
 Carter, Hastings & Howe..... 15  
 Chatham National Bank..... 29  
 Clark & Coombs..... 48  
 Cross & Bequelin..... 28  
 Crossman, Charles S., & Co..... 24  
 Crouch & Fitzgerald..... 51  
 Crown and Lion Watch Cases..... 43  
 Day, Clark & Co..... 30  
 Deitch Bros..... 22  
 Didisheim, Hipp., & Bro..... 12  
 Dorfinger, C., & Sons..... 29  
 Dubois Watch Case Co..... 8  
 Dueber-Hampden Co..... 11  
 Eaton & Glover..... 30  
 Eisenmann Bros..... 18  
 Eliassof Bros. & Co..... 35  
 Esser & Barry..... 34  
 Fahys, Jos., & Co..... 41  
 Fairchild & Johnson Co..... 52  
 Field & Beattie..... 48  
 Foster, Theodore W., & Bro. Co..... 2  
 Frankel's Sons, Jos..... 17  
 Freund, Henry, & Bro..... 39  
 Friedlander, R., L. & M..... 52  
 Fuchs, Ferd., & Bros..... 48  
 Goldsmith Bros..... 37  
 Goodfriend Bros..... 15  
 Goodnow & Jenks..... 2  
 Gorham Mfg. Co..... 26  
 Harris & Harrington..... 52  
 Haskell, H. C..... 48  
 Hayden Mfg. Co..... 12  
 Hedges, Wm. S., & Co..... 14  
 Heimberger & Lind..... 51  
 Howard Sterling Co..... 7  
 Hrabka, Louis W..... 39  
 Jacot & Son..... 51  
 Juergensen, Jules..... 44  
 Kahn, L. & M., & Co..... 52  
 Kahn's Sons, James..... 21  
 Ketcham & McDougall..... 51  
 Knowles, Dr..... 48  
 Knowles, J. B. & S. M., Co..... 9  
 Kohn & Co..... 18  
 Kohn, Alois, & Co..... 30  
 Lady Racine..... 50

Lederer, S. & B., Co..... 52  
 Ledos Mfg. Co..... 44  
 Lelong, L., & Bro..... 52  
 Levy, L. W., & Co..... 31  
 Lewis, Fred W., & Co..... 21  
 Lind, Thomas W..... 4  
 Lintz, Jules J..... 41  
 Lissauer & Co..... 23  
 Lorsch, Albert, & Co..... 52  
 Mabie, Todd & Bard..... 48  
 Mallicet, C. G., & Co..... 14  
 Mathews & Prior..... 21  
 Mathey Bros., Mathez & Co..... 48  
 Mauser Mfg. Co..... 30  
 Mercantile National Bank..... 32  
 Mossberg & Granville Mfg. Co..... 8  
 Mount & Woodhull..... 14  
 Myers, S. F., Co..... 32  
 New England Watch Co..... 5  
 Nohle, F. H., & Co..... 38  
 Neuhaus, Theodore, & Co..... 35  
 Nissen, Ludwig, & Co..... 16  
 Omega Watches..... 8  
 Oppenheimer Bros. & Veith..... 14  
 Patek, Philippe & Co..... 34  
 Potter, Wm. K..... 52  
 Powell, S. C..... 24  
 Providence Stock Co..... 52  
 Reichhelm, E. P., & Co..... 13  
 Reisner, L. C., & Co..... 3  
 Remington Typewriters..... 35  
 Rich, H. M., & Co..... 32  
 Rogers, Wm., Mfg. Co..... 35  
 Roy Watch Case Co..... 35  
 Rumpp, C. F., & Sons..... 48  
 Saunders, John F..... 15  
 Schulz & Rudolph..... 44  
 Selwyn Importing and Trading Co..... 34  
 Sherwood, John W., & Co..... 10  
 Simmons, R. F., & Co..... 30  
 Simmons & Payne..... 8  
 Simons, Bro. & Co..... 24  
 Smith, Alfred H., & Co..... 16  
 Smith, Wm., & Co..... 30  
 Stern Bros. & Co..... 21  
 Sternau, S., & Co..... 22  
 Strasburger, Byron L., & Co..... 18  
 Strasburger's Son, Louis, & Co..... 19  
 Street, Geo. O., & Sons..... 30  
 Sussfeld, Lorsch & Co..... 46  
 Towle Mfg. Co..... 38  
 Treibs Bros..... 13  
 Trenton Watch Co..... 24  
 Wadsworth, G. F..... 38  
 Waite-Thresher Co..... 40  
 Wallace, R., & Sons Mfg. Co..... 6  
 Waterman, L. E., Co..... 29  
 Westphal, W. C. A..... 52  
 Wheeler, Hayden W., & Co..... 20  
 Whiting, F. M., & Co..... 4  
 Wood, Chas. F., & Co..... 52  
 Wood, John R., & Son..... 51  
 Wood & Hughes..... 48  
 Woods & Chattelier..... 21

**AT ONCE**—First-class watchmaker, jewelry repairer and to wait on trade; references from former employers; steady job to the right man; salary according to ability. Address Box 121, Hopkinsville, Ky.

**WANTED**—An experienced salesman on salary and commission; one acquainted with the Newark manufacturers and large New York dealers; best of references required. Address H., care Jewelers' Circular.

**WANTED**—Traveling salesman on commission to sell a small but well assorted stock of colored and precious stones; one representing a diamond or mounting house preferred; mention territory and references. Address "Importers," care Jewelers' Circular.

**AFTER JAN. 1**—A first-class manufacturing jeweler and stone setter who can make all kinds of diamond mountings, cluster work, and understands enameling and the use of dynamos for gilding and plating, as foreman in a newly equipped shop with six to eight men; highest salary and permanent position to right man; best of references required. Address G. O., care Jewelers' Circular.

**Business Opportunities.**

**FOR SALE**—A good jewelry and repair business; New York town of 3,000; established 1887; repairs \$60 to \$70 per month; invoice about \$600. Address "S. 78," care Jewelers' Circular.

**FOR SALE**—Well established small jewelry and optical goods store on leading business street in Brooklyn; exceptionally good opportunity for fine watchmaker with small capital. Address R. A., care Jewelers' Circular.

**I BUY JEWELRY STOCKS**.—Retailers or wholesalers wishing to dispose of surplus or entire stock of diamonds, watches and jewelry can find quick cash buyer by addressing John Grossberg, 104 2d St., New York.

**JEWELRY STOCKS BOUGHT**—Retailers wishing to dispose of surplus or entire stock of diamonds, watches and jewelry can find quick, cash, strictly confidential buyer by addressing S. Marx, 22 Lisperard St., New York City.

**Miscellaneous.**

**WHEN WANTING** a good lathe, remember the "Moseley"; there is none better, many not as good; their reputation has been built up by good design and good workmanship with very little wind; wind alone will not do it; send for our new illustrated circular. When interested, write your jobber, or Moseley Lathe Co., Elgin, Ill.

**TO RENT** in Silversmiths' Building, CHICAGO.

A fine office on Wabash Avenue front, with north and east light, 20 x 42 feet, adjoining the Gorham Mfg. Co.'s salesroom on the sixth floor. Most desirable location in the city. For terms apply to

**GORHAM MFG. CO.,**

Silversmiths' Building, CHICAGO.

**SALESMAN** to travel south

wanted with an up-to-date line of medium price Solid Gold Jewelry (Diamond set, &c.), extensive line of Sterling Novelties and high-grade Gold-Filled Vest Chains, Lorgnette Chains, Dumb-bell Links and Brooches. Salary, \$2,000 and expenses. Don't answer this unless you have established trade south, and can furnish high-grade references.

Address with particulars, "WIDE AWAKE,"

Care of JEWELERS' CIRCULAR.



# A. & B.

## HEADQUARTERS

FOR

## Waltham Watches

EVERY GRADE.

## AVERY & BROWN,

68 Nassau St., New York.

### BEER STEINS,

For Prizes, Club Use and Home Decoration.

75 Cents to \$4.50 Each.

L. W. LEVY & CO.,

Novelties and Optical Goods,

194 BROADWAY, NEW YORK.  
Successors to Levy, Dreyfus & Co.

### Selwyn Importing and Trading Co.

STAG HANDLES,

BOARS' TUSKS,

IVORY, BUCKHORN, Etc.,

For the Cutlery Trade and for Silversmiths.

14 E. 17th Street, New York.

## PATEK, PHILIPPE & CO., GENEVA, SWITZERLAND,

MAKERS IN THE HIGHEST QUALITY OF

### Fine, Plain, Complicated And Decorated Watches

IN 15 DIFFERENT SIZES.

NEW YORK OFFICE, 68 NASSAU ST.

INTERCHANGEABLE PARTS.

ALFRED G. STEIN, Representative.



**ESSER & BARRY,** Largest Manufacturers of  
... Cheap and Medium Priced  
**IMITATION DIAMOND JEWELRY**  
IN AMERICA.

Write us for samples of almost anything with an Imitation Diamond in it.  
MAIN OFFICE AND FACTORY, 101 SABIN ST., PROVIDENCE, R. I.

### Providence.

#### TRADE CONDITIONS.

There is no indication here of anything in the nature of a falling off in the almost unprecedented period of prosperity which has been enjoyed for some months by manufacturers of jewelry. Rather the volume of business seems to increase. One manufacturer, whose shop has been running regularly 12 and 14 hours a day since September, says that he could easily do double his present large business if the capacity of his plant were only great enough. Nearly every factory, weeks ago, reached the absolute physical limit of production and has since been running on that basis. Workmen are beginning to become worn out by working long days, week after week, and no good plan for bettering this condition of affairs seems to have been arrived at. Some shops have individual power plants and might be able to run their machinery 24 hours a day if it were not for certain elements of difficulty, such as the necessity of having the same superintendents, foremen and managers of departments to see the work carried through all the different stages of manufacture. For this and other reasons the plan of running a day and a night force on the same plant appears to be impracticable.

The Cutler Jewelry Co. are removing their plant from 195 Eddy St. to a new and more advantageous location at 19 Calender St.

The funeral of Mrs. Elizabeth C. Ostby, wife of Englehardt C. Ostby, of the Ostby & Barton Co., was solemnized at 1 o'clock last Wednesday afternoon, in the presence of a large assemblage of friends at her late residence, 230 Waterman St.

Among the representatives of jobbing firms who placed orders with Providence manufacturers the past week were Mr. Kurtz, for M. Friedman & Co., New York; James Smith, of James Smith & Son, Brooklyn; A. Bader, New York, and Mr. Teale, buyer for Rest Fenner Smith Co., New York.

The Rhode Island Jewelry Co., recently organized in New York with stated capital at \$10,000 and S. C. Wolf and L. M. White, New York, and David Blum, Brooklyn, as incorporators, are to be located in this city at 19 Calender St., where business will be begun at once to take advantage of the rush of trade now being experienced in all branches of the jewelry industry. Samuel C. Wolf is to attend to the financial affairs of the new concern and will represent the company on the road, while Philip Riley will manage the factory.

The Eminence Jewelry Co., Eminence, Ky., have left that town.

### The Attleboros.

Bliss Bros. and E. D. Gilmore & Co. made their employes happy on Thanksgiving day by gifts of turkeys and money.

Mr. and Mrs. James H. Arthur, whose wedding was mentioned in these columns last week, are enjoying a honeymoon tour through Washington and Philadelphia.

Mr. Williams, buyer for Robert Johns, and A. Stone, buyer for Stone Bros., both of Chicago, are booked to call on the local manufacturers and place orders this week.

Sadler Bros., South Attleboro, have added the manufacture of mounted combs to their business, and have succeeded unexpectedly well in introducing them to the trade.

The erection of the new building for the Frank Mossberg Co., corner of Mill and S. Main Sts., Attleboro, is completed, and the next 10 days will see all the machinery installed and the place in actual operation.

William J. Ritchie, the jeweler whose disappearance was mentioned last week, has returned to his family. He tells a dramatic tale of being drugged and kidnapped, which the local press has given to the public in elaborate style.

George L. Shepardson, of C. A. Marsh & Co., was summoned to Mansfield last week by the police. In the absence of his father and mother from their home in that town, the house had been ransacked and much valuable booty secured.

The traveling men are getting ready their lines of samples, in order to start the very day the Christmas rush shows marked signs of slackening. It is the word of men in a position to know that there are to be an unusually small number of new designs.

J. Lyman Sweet, of R. F. Simmons & Co., who has been exiled from home for several years by a long illness, returned Saturday and was warmly greeted by his old friends. It is hoped his recovery is sufficient to allow him to remain and resume his business, for he has always been one of the town's most public spirited citizens.

The construction work at the new Bigney building is completed. The factory is now, according to all the jewelers who have visited it, the most complete in which jewelry is manufactured in the United States. No factory ever built in town attracted so much attention from other jewelers. It was criticised with scathing freedom by other manufacturers, who declared that the arrangement of its floors made it the darkest shop in town, and that the arrangement of the stamp blocks inside would make it impossible to set up the machinery to advantage. The completed building shows these two points to be the strongest instead of the weakest in the whole plan. The darkest corner is lighter than many other factories in the town, and there is less disadvantage from the stamp block supports by a wide margin than in any shop in town of over two stories. Visitors now have only words of praise. S. O. Bigney & Co., Providence, and F. H. Sadler & Co. and Macdonald & Culver, Attleboro, are preparing to move into their quarters directly. Ninety-ninths of the 60,000 feet of floor space have been hired, and the first of the year will see the shop filled with tenants.

**Pittsburgh.**

Arthur Arnheim, son of J. Arnheim, Allegheny, is a victim to typhoid fever.

Mr. Bygate, Scottsdale, Pa., was here last week. The firm has made extensive alterations and improvements.

G. A. Boss, McKee's Rocks, Pa., was in the city last week, his first trip since his recovery from typhoid fever.

James M. Stoner, Jr., receiver for George W. Biggs & Co., filed his account last week. A balance of \$8,676 remains to be turned over to the trustees.

E. A. Bloser, New Kensington, Pa., will remove to his new store in the same town on Dec. 9, and will inaugurate a quite unusual "opening." He has engaged the two brass bands and the only drum corps of the town for the musical programme, and will furnish an oyster supper to all patrons.

Among the out-of-town dealers in the city last week were: Carl H. Leighner, Butler, Pa.; F. M. Langnecker, New Brighton, Pa.; E. H. Schaefer, Beaver Falls, Pa.; J. W. Caler, Beaver, Pa.; Benjamin Robinson, Clarksburg, W. Va.; Fred Laban, Steubenville, O.; F. B. Satterthwaite, Mercer, Pa.; Durr Bros., New Martinsville, W. Va.; Mrs. G. W. Schmidt, McDonald, Pa.; A. Masher, East Palestine, O.; A. G. Crabbe, Hyndman, Pa.; J. E. Miller, Glen Campbell, Pa.; L. C. Grassell, Mahoningtown, Pa.; John Z. Simpson, Blairsville, Pa.; J. F. Murphy, Dawson, Pa.; F. W. Koehler, Sharon, Pa.; Max Wilson, Indiana, Pa.; T. C. Donahue, Punxsutawney, Pa.

John A. Scott, of Findlay, O., received a stolen watch on Nov. 27, in a remarkable manner. His residence was entered by burglars about six weeks ago, and among the articles stolen was a gold watch. A few days ago a man residing in East St. Louis, Ill., left a watch with C. W. Hoen, a jeweler of that place, to be repaired. When Mr. Hoen started to register the watch he noticed his private repair mark on the inside of the case. He looked up his books and discovered that he had repaired the same watch for Mr. Scott while he was engaged in business in Findlay in 1891. He communicated with Mr. Scott, thinking that perhaps the watch had been stolen from him. The East St. Louis man purchased the watch in Toledo. As a result of the letter to Mr. Scott the watch was returned to him, and an effort will be made to apprehend the thief upon the clues in possession of the Toledo police.

**Columbus, O.**

I. Kleeman has moved his store to 166 N. High St., where he will have a very much better location.

The case of the National Cash Register Co. against the New Columbus Watch Co., the Hallwood Cash Register Co. and Jerome T. Gratingny has been assigned to take place in the United States Court here this week.

The Ellsworth Bros. Co., of Cleveland, were incorporated a few days ago by Frank H. Townsend, L. E. Ellsworth, F. F. Stranahan, W. J. Wilson and M. M. Ellsworth, with a capital stock of \$50,000. The company propose to manufacture and deal in soda water apparatus, bottling machinery, silver ware and silver plated ware.



**Our New...  
Jewel Case**



has been pronounced by competent judges the best in size, shape, workmanship and fitting, in the market.

**Roy Watch Case Co.,**

Makers of SOLID GOLD CASES,

21 Maiden Lane,

New York.



TRADE-MARK REGISTERED.

**SEE THE TWO ANCHORS AND THE NAME ROGERS**

TRADE MARK:

...ON...

Like This



**ROGERS**



**"ANCHOR" BRAND**

**Silver Plated Ware.**

Get the Silverware which bears the above impression and then nobody can have any better than you'll have in the ROGERS

ANCHOR BRAND. New designs all the time. Same through and through quality all the time. The Rogers Anchor Brand is made only by us.

Factories:

Hartford, Conn. Norwich, Conn.  
Wallingford, Conn. Taunton, Mass.

**WM. ROGERS MFG. CO.,**

HARTFORD, CONN.



**Eliassof Bros. & Co.,**

IMPORTERS AND JOBBERS OF

**DIAMONDS, WATCHES, JEWELRY,**

9-11-13 Maiden Lane,

NEW YORK.

Materials, Tools and Optical Goods.

ALBANY OFFICE: 62 & 64 STATE STREET.



Absolutely Reliable Always

**Remington  
Typewriter**

STANDS THE TEST OF CONSTANT SERVICE

Wyckoff, Seamans & Benedict  
327 Broadway, New York

THE EMPIRE WESTWARD TAKES ITS WAY

# WESTERN SUPPLEMENT

## OF THE JEWELERS' CIRCULAR

VOL. XXXIX.

NEW YORK, WEDNESDAY, DECEMBER 6, 1899.

No. 19.

### Chicago Notes.

All communications in reference to the Chicago department of *The Jewelers' Circular*, addressed to Stephen Parlin, 1522 Lill Ave. (Telephone, Lake View 397), Chicago, will receive prompt attention.

H. G. Nye, Chicago manager for C. Rogers & Bros., returned last Tuesday from an extended trip east.

Will Manheimer is just in from a trip for Louis Manheimer and reports good ante-holiday trade in all sections.

Robert Crawlford, for many years watchmaker for Charles H. Reynolds, Alpena, Mich., died recently from tumor on the brain.

J. R. Davidson, Chicago manager for the T. Zurbrugg Co., expects to visit the eastern factory the latter part of the month.

The many friends of J. W. Tice will be glad to know that Mrs. Tice, who has been dangerously ill, is improving in health.

Mr. Payson, connected with the Seth Thomas Clock Co. here, came in from his trip suffering from a grippy cold that laid him up.

The young daughter of Charles Spencer, of the Stein & Ellbogen Co., who has been quite seriously ill, is improving in health rapidly.

Benj. Allen & Co.'s salesrooms present an active scene these days, with over 100 employes on the floor. The house is doing a phenomenal business.

Mr. Rodenberg, S. & B. Lederer Co.'s Chicago representative, who is temporarily at Mount Clemens for rheumatism, writes he is feeling quite frisky and expects to leave shortly for Chicago.

Crossed wires caused a fire scare in the third floor of the building at 241-243 State St., occupied by Spaulding & Co., jewelers, on the morning of Nov. 28, but the incipient blaze was extinguished before any great damage was done.

The banquet committee of the Chicago Jewelers' Association came together last Tuesday and took another step forward by appointing the following sub-committees: On hall, Messrs. Sercomb and Flershem; on speakers, Messrs. Dodgshun and Vogell; on printing and invitations, Mr. Todd. The convenience of the prospective speakers will be ascertained before the committee on halls will report.

Mrs. Grace Miles McGredy, wife of Frederick McGredy, and daughter of the

late Josiah C. Haines, died Thanksgiving day after a severe illness from cerebrospinal meningitis. She had been removed to a hospital a few days before her death to undergo a surgical operation, but was too low to be operated on. The department heads and salesmen of Lapp & Flershem, with whom her husband, Frederick McGredy, had been a co-worker for 15 years, attended in a body.

Buyers here last week in person were quite numerous, but some difficulty was experienced in securing the names on account of the busy condition of the jobbing houses. Those reported included: J. E. Daly, Necedah, Wis.; H. A. Kingsbury, Garrett, Ind.; E. C. Pike, Kankakee, Ill.; H. A. Bowen, Kewaunee, Ill.; J. C. Peers, Rockford, Ill.; L. Ratzesberger, Milford, Ill.; Fred Eynatten, Peoria, Ill.; Rovelstad Bros., Elgin, Ill.; A. M. Smythe, Elgin, Ill.; Fred A. Marean, Belvidere, Ill.; Frank Smith, Pontiac, Ill.; A. J. Leach, Casson, Minn.; J. P. Bader, Clarksdale, Miss.; W. H. Parker, Sanborn, Ia.; J. W. Neasham, Ottumwa, Ia.; E. E. Chandler, Boone, Ia.; Mr. Christophersen, of Christophersen & Amundsen, Menominee, Mich.; W. P. Reichert, Canton, Ill.

### Pacific Coast Notes.

Fetzer Bros. have started a new store at Weaverville, Cal.

A. D. Rickey, a jewelry importer, is in Los Angeles, Cal., on business.

G. A. De Mandeler recently opened a new jewelry store at 87 W. Congress St., Tucson, Ariz.

J. H. Mitchell opened a line of jewelry as a department in his drug store at Willows, Cal., on Dec. 1.

J. B. Rowe, jeweler, 402 N. Main St., Los Angeles, Cal., has opened another store at 217 N. Spring St., that city.

H. R. Eckstrom, jeweler, Santa Rosa, Cal., has presented to the new German Lutheran Church, that city, a handsome clock.

F. W. Hawley, of San Jose, Cal., has opened a jewelry store corner of Light-house Ave. and 16th St., Pacific Grove, this State.

O. H. St. John, Fort Bragg, Cal., announces that he has not sold out his jewelry business in that city, as reported a short time ago.

C. L. Reynolds, jeweler, Roswell, N. M., who left for the east last Spring after a residence of several years in that city, has returned, and will probably start in business again.

Mr. Scudder, optician, San Diego, Cal., has formed a partnership with Miss Morrell, a graduate of the Chicago Ophthalmic College, and will open establishments at San Diego and San Bernardino, Cal.

J. S. McGinnis has brought suit in Justice Rosenthal's court, San Jose, Cal., against C. G. H. MacBride to recover the sum of \$100 alleged to be due upon an assigned claim from John M. Bonnet, jeweler, Zanesville, O.

A big Winter trade is expected by George Jordan, jeweler, Redlands, Cal., and he is preparing for it. The store is now being painted and papered and some alterations are being made to add to the attractiveness of the place.

Eugene Smith was arrested at Logan, Utah, recently upon suspicion of being one of the parties who burglarized Wm. Luthy's jewelry store, Preston, Idaho. The other party arrested for complicity in the crime is a young fellow named Brown, whose home is in Bear Lake Co., Idaho. Both men deny any knowledge of the burglary, and none of the stolen goods was found upon either. Smith was taken before the Preston Justice, but as no evidence was found against him he was exonerated.

### Kansas City.

Chas. Lasky, 1019 Main St., is selling out his stock at auction.

Although Clem B. Altman has been occupying his new building for the past two weeks, it has just been entirely completed. It is now one of the handsomest jewelry stores in the west, both in decorations and furnishings, and its location, 11th and Walnut Sts., is one of the best in the retail district of this city.

Harry Carswell has just completed a very handsome and novel cup to be presented to the Kansas City Fire Department by the members of Co. E, of the 20th Kansas Volunteers, who have recently returned from Manila. The body of the cup is made from a projectile fired from a Spanish ship, and was secured by one of the men of Admiral Sampson's fleet. The wooden pedestal is made from a piece of wood from one of the doors to Morro Castle, which was secured by a soldier of this city, who was detailed to guard the castle, and managed to secure this piece. The whole cup is handsomely engraved and bears the names of the entire muster roll of Co. E, its donors. The designing and work were done entirely by Mr. Carswell.

# Life Insurance

is a good thing—for others when you die—but the best way to enjoy life is to make money while you are living. The best sort of a

# Business Insurance

is to sell whatever you have to sell at the highest price. We pay the highest price for **SWEEPS** and **OLD GOLD AND SILVER**. How can we do it? Because of our great facilities and because we get every particle of gold and silver out of the material you send us.

As to our reliability we refer you to any Chicago jobber, any Chicago bank, or any one of the upward of 10,000 jewelers who send their shipments to us.

Furthermore, we assume all the risk! All you have to do is to

## Send us your Old Gold and Silver.

We send you our check on receipt of your package and if our valuation is not satisfactory to you we will return your shipment intact and pay all express charges. You're a sure winner.

# GOLDSMITH BROS.,

Sweep Smelters, Refiners and Assayers,

63-65 Washington Street, ✻ Works: 5826 Throop Street, ✻ Chicago.

**San Francisco.**

**TRADE CONDITIONS.**

Buyers are flocking into San Francisco. Another week of heavy rains has given great encouragement to the country trade, and purchases so far indicate that the holiday trade of San Francisco jobbers this year will be one of the greatest on record. The demand for sterling silver novelties is exceptionally strong, and it is said there is already a scarcity in a number of lines with no immediate prospect of a change in the situation. Fancy decorated clocks in cuckoo and other styles seem to have become quite a fad for holiday gifts.

A. Kuhlman, formerly of 129 Montgomery St., has removed to 510 Kearny St.

Bernard Neves, a jeweler of Oakland, Cal., has given a trust deed for his property for \$630.

**G. F. WADSWORTH,  
Watch Case Manufacturer  
AND REPAIRER.**

Everything in the line of Watch Case Repairing. Old English and Swiss Cases changed to take American Stem-wind Movements a specialty.

**OLD CASES MADE NEW.  
CHARGES REASONABLE.**

Silversmiths' Building, CHICAGO.

**ABSOLUTELY THE BEST.**



Manufactured by F. H. NOBLE & CO.,

103 State St., Chicago.

Sold by all Jobbers.

George H. Wilcox, first vice-president of the International Silver Co., arrived in San Francisco a few days ago.

Isadore Lewis, retailer, formerly of 6th St., near Mission, has moved to a new and better location on 9th, near Market Sts.

E. W. Perkins, Ione, Cal., was in San Francisco last week and bought a complete outfit for watchmaking and jewelry work.

A. F. Radke, who has been with Geo. W. Ryder, San Jose, Cal., for a number of years, is now with F. W. Carter, Santa Rosa, Cal.

D. Hyman and D. Michelson, Sacramento, Cal., were in San Francisco last week. They report a good business being done at the capitol city.

F. W. Ward and H. C. Ray, representing the retail trade of Visalia, Cal., reported a splendid prospect for trade in the upper San Joaquin valley.

Colonel Andrews, proprietor of the Diamond Palace, owing to the great popularity of silver novelties, has added a line of these goods to his stock for the holiday trade.

James C. Kane, for many years with Shreve & Co., who recently returned with the California volunteers from Manila, died at the Presidio Hospital, in this city, on Nov. 17.

The Baldwin Jewelry Co. have opened a branch store at the corner of 3d and Stevenson Sts., this city. This location is only a short distance from lower Market St. and should catch a large part of the down-town trade.

Advices from Manila state that Felix Ullman, a retail jeweler of that city, is in some trouble with the Customs authorities. Just what the trouble is is not clear, but Mr. Ullman is now on the bond to appear before the authorities when required.

The First Regiment of Tennessee Volunteers has presented to Mrs. A. S. Townsend a handsome silver loving cup as a token of their regard. The cup bears the date of Nov. 22, 1899, the day on which the regiment was discharged. This cup is now on exhibition at Shreve & Co.'s.

Hammersmith & Field took advantage of the interest aroused by the Thanksgiving

day football game to dress their windows in honor of the two rival universities. One window was dressed entirely in cardinal for the eyes of the Stanford people, and the other in blue and gold, in honor of Berkeley.

Among the buyers here visiting the jobbers last week may be mentioned P. Engel, Marysville, Cal.; J. H. Pearson, Randsburg, Cal.; E. I. McManus, San Luis Obispo, Cal.; H. H. Wiendieck, Red Bluff, Cal.; H. Jacoby, Oroville, Cal.; Mr. Schuchard, Salinas, Cal.; Y. H. Boudreau, Modesto, Cal.; J. Glick, Stockton; J. D. White, Santa Cruz; F. T. Schumi, Pleasanton; A. DeNui, Virginia City, Nev.; O. H. St. John, Fort Bragg, Cal.; S. D. Schoenfeldt, Red Bluff, Cal.; P. Johnson, Angel's Camp; H. Hauschildt, Haywards, Cal.; E. Praet, Woodland, Cal.

**Louisville.**

**TRADE CONDITIONS.**

Trade conditions were never brighter in Louisville than at present. More than a score of new stores have opened their doors for business right in the heart of the city. Plans for several new sky-scraping buildings are in progress. A number of factories have just moved their plants here on account of exemption from taxes, due to a city ordinance recently adopted. Louisville jewelers are anticipating a splendid holiday trade, which has already begun to show with a handsome increase in sales.

Detective Daly arrested Walter Gatewood Wednesday afternoon, charged with burglarizing Joseph Wagner's jewelry store, Market St., last Sunday.

W. J. Bate, for many years with Wm. Kendrick's Sons, while out hunting a few days ago, was shot by some over-zealous sportsman, who fired in his direction. Mr. Bate's hand was badly mangled.

**Indianapolis.**

A new jewelry store has been opened at Lafayette, Ind., by L. N. Philbin.

Chris Bernloehr, jeweler, Pembroke Arcade, took the 32d degree in the Scottish Rite last week.

Philip Koch, New Albany, Ind., has almost completely recovered from his recent stroke of paralysis.

The robbery of the Columbia Jewelry Co., Louis Haase, manager, continues to remain a mystery, as no clue has been discovered.

Charles W. Se Legue has opened a repair and engraving shop at Logansport, Ind. Mr. Se Legue was formerly with J. D. Taylor, also of Logansport, Ind.

Buyers at the wholesale houses were numerous last week. Among them were: W. W. Barton, Milroy, Ind.; Joseph Hummel, Jr., Muncie, Ind.; Aug. Anderson, North Salem, Ind.; W. R. Adams, Camden, Ind.; L. J. Small, Carmel, Ind.; J. W. Thompson, Danville, Ind.; L. C. Phillips, Carbon, Ind.; A. O. Means, Greenwood, Ind.; H. W. Bacon, Spencer, Ind.; Helton Pauley, Bloomington, Ind.

**Georgian STERLING SILVER.**

In Complete Table Service—

French Gray Finish.



COFFEE SPOON.

**TOWLE** MANUFACTURING CO.,  
CHICAGO.

NEWBURYPORT, MASS.



**THEODORE NEUHAUS & CO.,**

Lion Building, 5th and Elm Streets,  
CINCINNATI, OHIO.

SPECIAL WORK TO ORDER.

**Gold and Silver Smiths.** MEDALS, BADGES, SCHOOL PINS,  
Repairing and Refinishing Given Special Attention.

All Grades.

**St. Louis.**

Goodman King returned from his New York trip on the 28th ult

Louis E. Hirsch & Co. have opened a photographic supply store at 206 N. 6th St.

Arthur Kroenecke, a recent graduate from a local watchmaking school, has embarked in business at Concordia, Mo.

J. Reed Elliott, one of the traveling force of Eisenstadt Mfg. Co., lost his wife on Dec. 1. The lady was only 25 years of age, and her death resulted from typhoid fever.

One of the devotees of cocked hat among the jewelry fraternity is Gus Loeffel, of 1224 S. Broadway. He recently made the highest score seen for some time on a local alley.

Among out-of-town jewelers here last week were: E. R. Matters, Neosho, Mo.; E. K. Kane, Pinckneyville, Ill.; Wm. Westphal, St. Charles, Mo.; Albert G. Cordes, with C. H. Bard, Sedalia, Mo.

**Minneapolis and St. Paul.**

Dave Michaels, with S. B. Abeles, Minneapolis, had his arm dislocated at the elbow while playing football last week.

A. L. Mealey, Delano, Minn.; A. Hawkins, Blue Earth City, Minn., were country buyers in the Twin Cities the past week.

F. J. Schisler, who some time ago closed out his business at Blooming Prairie, Minn., is now with the Union Watch and Novelty Co., Minneapolis.

Harry S. Aicher and Joe Aicher, traveling representatives for the A. F. Towle & Son Co., Greenfield, Mass., have returned from the last trip of the season and will remain in Minneapolis until after the holidays.

Owing to the death of Elmer Fiske, of Fiske Bros., 32 Washington Ave. S., Minneapolis, the entire stock is being sold at auction. The estate, it is announced, is to be closed. The sale began Dec. 2, at 10 o'clock A. M., under the direction of Sam Martin, jewelers' auctioneer.

**Omaha.**

C. L. Shook, of the Shook Jewelry Co., has been ill for a week.

Dr. Seymour, who has been located in Omaha for several years, has established himself in the optical business in Chicago.

Jos. P. Frenzer has made some excellent sales during the past 10 days. Last Monday he sold a fine, steel-blue stone without a flaw, 1½ karat in weight, for \$500. This particular stone was of a quality not often seen in this part of the country; one which always commands a good price, in large cities, where there is more demand for such gems.

**Detroit.**

George B. Wiggin, for 18 years a die cutter for Roehm & Son, died on Saturday at his residence here of consumption.

Frank J. Roehm, formerly of Roehm & Son, who recently started a repair shop and watch store in the Banlet block, has just added a line of gold jewelry and novelties.

The silver service for the new steamer being constructed for the Soo Steamship

Co. will be manufactured by Reed & Barton, and will be furnished by Traub Bros. & Co., Detroit.

**Pacific Northwest.**

Dr. J. H. Durfee, optician and jeweler, has located at Northport, Wash.

A new jewelry store will be opened at Roseburg, Ore., by Chas. Kelly, a recent arrival from Myrtle Creek.

H. B. Meyer has purchased the Crater building, Medford, Ore., and will put in a large stock of jewelry.

Dr. Lowe, optician, has purchased the optical department of Joseph S. Luckey's jewelry store, Eugene, Ore.

George E. Ellis, jeweler, Toronto, Ont., is displaying a large stock of diamonds at the Dover jewelry house, Nelson, B. C.

Felix Friedlander, representing W. Friedlander, Portland, Ore., was in Sumpter, Ore., last week with a full line of jewelry, and he says he will visit the adjacent mining districts.

**Cincinnati.****TRADE CONDITIONS.**

Jobbers and manufacturers are very busy and the retail trade is picking up. The mails are heavy and all the banks are busy. Fewer failures are recorded for this season than in many years, and the outlook for January assignments does not portend many in the jewelry interests. The out-of-town jeweler has shown marked improvement in both collections and sales this Fall.

Owing to the order rush of the past week Jos. Noterman & Co. have been obliged to add office help and new tables in the counting room to facilitate the factory work.

Albert Bros. sold more goods the past week than they sold in one season in other years.

The great demand upon the Jewelers' Co. for fancy rings has compelled them to increase their effort and work at nights.

Every bench in the Queen City Watch Case Co. factory is now occupied and still there is needed more help to aid them in getting out work promptly.

Max L. Jacoby was the solitary eastern man in town Saturday.

A. G. Schwab & Bro., Nov. 29, made a donation of \$25 to the general fund for the reception of the First Regiment of Tennessee at Nashville.

Frohman, Wise & Newman, who assigned a few years ago, have been discharged from bankruptcy, and they may now enter into business free from liability.

Charles Goetheim, who has been associated in the jewelry business for the past quarter of a century and who assigned his stock two years ago and went with the Duhme Jewelry Co., has been discharged from bankruptcy by the Hamilton County Court, and he has formed a partnership with Messrs. Feder and Holtzman in a banking firm, and will act as a broker.

Three boys were captured by the police last week selling stamps to drug stores which they had stolen from E. & J. Swigart, the wholesale material firm. One of the boys was employed at Swigart's, and he improved his opportunities to carry off pieces of jewelry, materials and stamps, which his brother and another boy sold. The charge of petit larceny was placed against them.

Among the out-of-town dealers here buying goods last week were: A. Clooney, Maysville, Ky.; A. Boiarsky, Charleston, W. Va.; M. Heisterman, of Heisterman & Zechman, Germantown, O.; J. L. Wanner, Aurora, Ind.; M. B. Ullery, Covington, O.; A. C. CaJacob, Wapakoneta, O.; John A. Worrell, Washington C. H., O.; C. E. Diefenbach, Brookville, O.; A. H. Beer, Versailles, Ind.; C. A. Gossard, Washington C. H., O.; R. Moss, Owensboro, Ky.; Chas. Rieckel, Cynthiana, Ky.; W. C. Gregory, Blanchester, O.; A. E. Axman, Franklin, O.; Chas. E. Hodgen, Kokomo, Ind. They all reported prospects for a big holiday trade.

Archie McPhee will open a jewelry store in Canton, O., about Jan. 1.



**NOW WHEN YOU RECEIVE A SPECIAL ORDER...**

*for something you may not just have in stock—a fine watch or piece of jewelry or some loose diamonds—write or wire us. Goods by return express—you can depend on it. Many jewelers know this by experience. We should also like to demonstrate it to you.*

**HENRY FREUND & BRO.,**  
11 Maiden Lane, NEW YORK.

**ELK GOODS A SPECIALTY.**

Established 1879. Manufacturer of

**LOUIS W. HRABA,**  **Fine Leather Goods**

29 East 19th St., New York. Exclusively for the Jewelry Trade.

### News Gleanings.

T. L. Williams, jeweler and optician, Quincy, Mass., is to occupy a store in Tirrell's block.

The creditors of E. E. Starr, Toledo, O., have appointed L. C. Miller as trustee of the property.

The Cardon Jewelry Co., Logan, Utah, will erect an electric clock in front of their establishment.

George F. Hussey, Haverhill, Mass., is confined to his home with a severe attack of pneumonia.

Owing to continued ill health A. O. Albin has decided to close out his business in Sayville, N. Y.

A jewelry establishment is being added to Mr. Warner's bicycle shop, 814 Broadway, Toledo, O.

Chas. E. Peterson, of Woodbridge, N. J., has opened a branch store at Grant's pharmacy, Carteret, N. J.

Arthur F. Smith, of Postville, Ia., has purchased a jewelry store at Waucoma, Ia., and taken possession.

Harold C. Ormsby, of Farmington, Me., is to open a jewelry store in the E. N. Merrill block, Skowhegan, Me.

Nov. 25 was the opening day of the new jewelry store of A. G. Hofman, Stevenson block, 205 Market St., East Liverpool, O.

Charles Kyle has purchased the jewelry department at A. M. Morriss & Co.'s drug store, Kerrville, Tex., from J. A. Eames.

R. S. Porter, watchmaker and jeweler, has severed his connection with J. Iverson, Stevens Point, Wis., and started a shop of his own in the Atwell block.

Jas. C. Beitel, Catasauqua, Pa., has taken in a new partner in the person of the son, Robert J., who since his school days has been associated with his father in the business.

James C. Berzine, who recently purchased Charles E. Elliott's jewelry business, Williamson, N. Y., has now purchased the jewelry store conducted by Mathew E. Van Doorn.

The police of Burlington, Ia., have recovered a large quantity of goods, including 27 articles of jewelry, stolen by a gang of shoplifters. Jeweler Geo. C. Henry has identified a number of these articles.

The lease of the store 119 N. Main St., Bloomington, Ill., has been transferred to W. H. Homuth. Mr. Homuth has been conducting a jewelry store at 101 N. Main St., and will now embark in the business on a larger scale.

A man named Conn was a few days ago arrested on the charge of conversion made by G. H. McKelvey, St. Joseph, Mo. Conn was employed by him in the jewelry store several months, and Mr. McKelvey charges that he appropriated \$40 to his own use.

H. V. Brown has taken the store at 517 Essex St., Lawrence, Mass., which has for 15 years been conducted by A. A. Spofford as a dry and fancy goods store. The front and the entire store have been remodeled. Mr. Brown carries a general jewelry stock.

F. Post, arrested on the charge of embezzlement at Biloxi, Miss., has been placed in jail in Baton Rouge, La. Post, up to a few months ago, conducted a jewelry store in Baton Rouge, and he is charged with embezzling a watch when he left.

Frank Beal, the young man who attempted to get away with \$2,000 worth of diamonds from the jewelry store of Solomon Joseph, Des Moines, Ia., as already reported in THE CIRCULAR, has been indicted by the grand jury. Beal entered the store, asking to be shown some stones. A clerk waited upon him. After looking over the tray of gems he grabbed it up and made a start for the door. He was apprehended. It is believed he had an accomplice.

Geo. Wettstein, Cedar Rapids, Ia., has just enlarged his factory and has now one of the finest and best equipped shops in the west. He has also put in a large, fine Emerson motor, larger dynamos for gilding and plating, three more polishing lathes, while all the other machinery is new and of the latest improved pattern. The firm is making diamond mountings, rings, studs and scarf pins in gold for its wholesale department, and working up a fine business, although it has not run the manufacturing department a year yet. Mr. Wettstein also does repair work for the trade; in fact, he is getting so much of this work that his men are working until 10 o'clock p. m., and he is anxious to get more first class men.

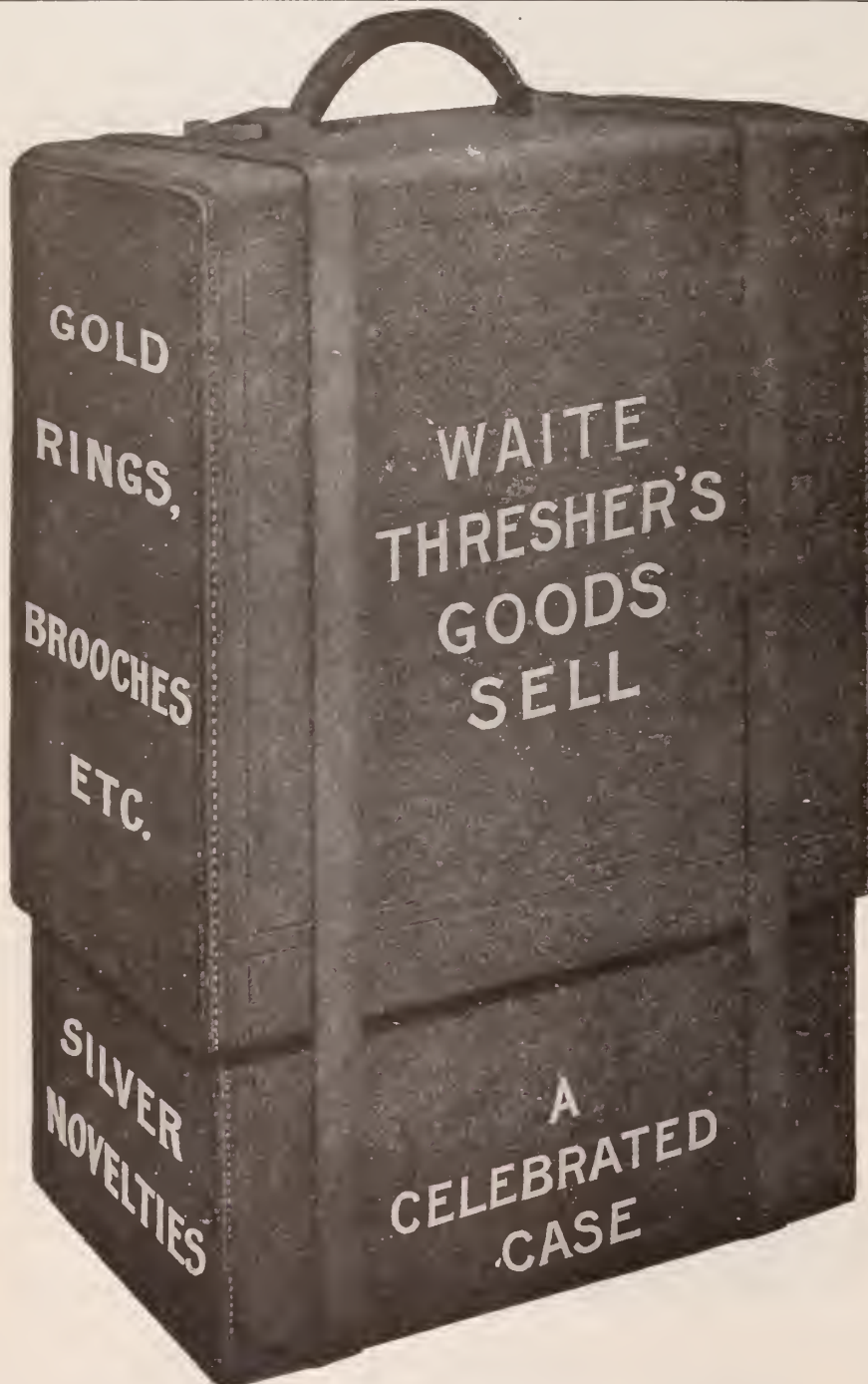

Remember that Articles Purchased from Samples Shown from the Above Celebrated Case are Quick Sellers at Popular Prices.

NEW YORK OFFICE, 11 John Street.



H. A. Dulin has advertised his jewelry business in McKinney, Tex., for sale.

C. P. Almroth has succeeded to the business of William James, Brookfield, Mo.

W. A. Townsend, La Porte City, Ia., announces that he will remove to northern Iowa.

Lewis Koethe has given a bill of sale on his entire stock of jewelry in Parkersburg, Ia.

D. C. Slusher has purchased the entire stock of jewelry, etc., of W. L. Orear, Odessa, Mo.

Fred Underwood has sold out his entire stock of jewelry in Laredo, Tex., to L. Daichs & Co.

Miesch Bros. have succeeded to the jewelry business in Clarksville, Tex., of Michael Miesch, Jr.

W. E. Bidwell & Co. have given a chattel mortgage amounting to \$2,150 on their stock of jewelry and fixtures in Perry, Ia.

The death is reported of R. R. Reid, on Nov. 23, who had been conducting a jewelry business in Seward, Neb., for his wife.

Wm. B. Joseph, Hudson, N. Y., is transforming the appearance of his store, paint, paper and a fine artistic taste being the mediums.

H. O. Bailey, formerly of Smith Center, Kan., has moved his stock of jewelry to Shawnee, Okla., and reports the outlook very encouraging.

Hanks & Kline, Westfield, Wis., have dissolved partnership, F. W. Kline taking full possession and M. W. Hanks buying out a jeweler at Benton.

Eugene Freeman, jeweler, Paola, Kan., has made arrangements for an auction sale for next week. Chas. Manor, of Kansas City, will conduct the sale.

Frederick W. Zimmer, for the past 22 years with Wm. H. VanKeuren, Poughkeepsie, N. Y., has opened a jewelry store at 8 Garden St., Poughkeepsie, N. Y.

Edward L. Rinkenback, Harrisburgh, Pa., has improved his store. A new workshop extends across the entire rear portion, and two large wall cases have been added.

Nov. 20 was opening day for the J. S. Lewis & Co. jewelry house, Ogden, Utah, and a splendid opening it was. The room was dressed in flowers and evergreens.

Samuel Fish, for a number of years past with Geo. W. Halliwell, Poughkeepsie, N. Y., has entered St. Stephen's College at Annandale, N. Y., to study for the Episcopal ministry.

William M. Snow, head of the silverware department of Quackenbush & Co.'s store, Paterson, N. J., died Nov. 26. He was suddenly taken ill three weeks ago with inflammation of the bowels.

Will Hudson, who has the management of the jewelry business of George Hudson, Winfield, Kan., has just returned to that city after spending some time visiting a sister living at Battle Creek, Mich.

L. A. Orr, of Conde, S. D., has purchased a half interest in the jewelry business of J. E. Reid, Rochester, Minn. It is reported that the new firm will erect a three story building in the Spring and engage more extensively in the manufacture of jewelry.

Albert W. Akers, aged 38 years, died of consumption, Nov. 15, at his home, 2509

N. Charles St., Baltimore, Md. He was unmarried and was in the jewelry business on Pratt St., near Charles, being successor to his father, Edward Akers, who was in business for 50 years.

Joseph May, recently released from jail, where he served a term for breaking a window in the Russ House, Harrisburgh, Pa., continued his operations on the main street of Carlisle, Pa., and broke the plate glass windows of several stores, among them E. H. Conlyn's jewelry store.

F. E. Ladd, 417 Main St., Springfield, Mass., has made extensive improvements in his store. The main store room has been enlarged by means of extending the show windows three feet farther toward the street. The windows are enlarged and supplied with new plate glass. The

door at the entrance also contains a plate glass window.

The formal opening, Nov. 25, of what is and will be known as the Mortimer block, corner Centre and Norwegian Sts., Pottsville, Pa., marked a distinct era in the business world of Pottsville. The new Mortimer building is an up-to-date structure, that greatly beautifies the locality. It is occupied by the Mortimer brothers, F. P. Mortimer, dry goods merchant, and W. H. Mortimer, jeweler. The jewelry store is finished in a fine and artistic manner. The furnishings are all of mahogany and of the latest pattern. Communication is possible with every floor in the building from the store room, and every convenience has been introduced to insure a speedy service.

## Another Victor.

When the crucial test comes, when quality tells, side by side with the conquerors Olympia and Raleigh stands

## THE BOSTON.



O size, 3 rows of pearls, made in Montauk,  
20 years' guarantee, and 14 F.K.,  
25 years' guarantee.

**Joseph Fahys & Co.,**

Established 1857.

FAHYS BUILDING, NEW YORK.

## VIEWS ON MERCHANDISING.

ADDRESS BY W. E. JENKINS, JEWELER, RICHMOND, IND., ON "CONCENTRATION AND SPECIALIZATION IN MERCHANDISING," BEFORE THE ECONOMIC LEAGUE.

### PART II.

[Continued from page 43, Nov. 29.]

NOW to come to the point: there are in modern concentration of merchandising certain features that do not accord with the principles of evolutionary growth. I refer to the establishment of completely equipped general stores, mostly located in the largest cities, carrying enormous stocks embracing every line of merchandise and offering to perform every professional service. "All kinds of merchandise," "Retailers of everything," are the mottoes of these marts. One advertises to supply every want from the cradle to the grave, from a physician to usher the individual into life to a funeral director to decently inter him; dentists and pharmacists, caterers, grocers, butchers, decorators. I have heard, but I do not vouch for it, that one department store in Chicago will move your house for you. Certainly they will transmute metals for you. I have seen a long line of apparently sane men and women waiting to get \$5 in gold for \$4.75. There are picture exhibitions, concerts, recitals, minstrel performances. Indeed we are in the atmosphere of farce comedy and extravaganza when we try to enumerate the strange variations that merchandising undergoes in the form of some of the modern metropolitan general stores. If this be evolution, it is from a different germ, and is actuated by different principles from those present in the case of the dry goods stores whose development we have traced. I find myself comparing these strange forms to the grotesque and monstrous developments of the saurian age. "Monsters of the prime, that tear each other in the slime."

I find it difficult temperately to enumerate the characters of this type. Its mere size is not unnatural, for a growth in size has been one of the features of the legitimate evolution we have considered. There are examples of the legitimate type fully as large.

It is first the scope of the yellow store's operations (I shall, for convenience, call them by this epithet. It has acquired by its association with a certain kind of journalism the exact shade of meaning I need). Many of the lines carried and the services proffered can obviously, under present conditions, yield no profit, but are sustained for the sensational publicity gained by catering to the classes whose tastes are formed by cheap melodrama and yellow journalism. The yellow department store colors all its methods with loudness, extravagance and glitter.

It makes a deliberate onslaught on the business of the single line merchants. The advertising columns of the yellow one will accuse the small special merchant of gross extortion, with asking profits of 200 and 300 per cent, whereas the yellow store has the same goods for a mere fraction of the other's price. The actual difference is

usually due to a deliberate sacrifice in order to create a false impression of cheapness. In one case that came under my notice a yellow store advertised copper plate engraved cards for 50 cents a hundred. I was informed by an employe that the engraving of the plate cost them 75 cents besides the cost of the cards and the work, the object of the drive being to create a false impression of cheapness that should lead to larger business in other lines. The loss was charged to advertising and paid from the profits elsewhere, and the legitimate engraver's business suffered from the natural assumption on the part of the public that he had all along been exacting an unfair price. The bulk of the advertising of the yellow store exploits goods which are slaughtered for purposes of sensational publicity. The profits are made on other lines, and are, in many cases, of a highly satisfactory nature. The small fry of merchandising would be glad to average such profits. Of course they must be great somewhere in order to equalize the heavy losses. I recently picked up an article in a large department store in New York marked 39 cents, for which I had just paid \$27 a gross, or 18 cents each. No doubt the yellow store paid something less, as it had many gross in sight. On the same counter were articles which I could not buy at wholesale for the price for which they were offered. These latter were probably the leaders or baits which led up to the purchase of the highly profitable article.

In addition to this jockeying of prices the yellow stores advertise bargains that they never intend to give. When Madam arrives breathless and demands that seal-skin wrap for \$4.98, she is informed that the last one has just been sold. Goods are handled by the yellow man as Napoleon handled his troops.

They are sent to slaughter in order to attract and hold attention while in another quarter another brigade of merchandise turns the flank of the pocket books, and carries off handsome profits prisoner. The demoralization wrought among the small fry of single line merchants amounts, in some cities, to extermination. And my proposition is that it has been due, in no small degree, to these sensational and fraudulent methods. Of course the public has been humbugged since long before Barnum's time, and there are frauds among small as well as big merchants, but the extent, the ingenuity, the disastrous success of the frauds perpetrated by the yellow merchants have never been duplicated—never the faintest approximation to them.

That they have effected legitimate economies nobody can deny. Their very size would make it possible to highly organize and specialize their business. And they would probably have been successful had they relied on these methods alone. But it is unlikely that they could have wrought the devastation they have without using them.

The small store in Chicago is passing rapidly as the result of the yellow store's rise. Even the smaller department stores of the legitimate type have suffered severely, and, in several instances, succumbed, to be sold out by the yellow ones

at bankrupt sale. During 1895, while the Ishmaelites of merchandising were generally thought to be taking large profits, certainly while their stores were crowded with purchasers, the greatest merchant in America was said, according to credible report, to be losing on an average \$2,000 a day in his retail business. Now, on a basis of real economy the legitimate merchant had every advantage, larger resources, better organization, unimpeachable reputation, but the quack had the patient's ear and his purse. Every word in every advertisement of this great reputable merchant stood for a reality and appealed to the self-respect and reason of the purchaser, and all values were actual, but down the street gold \$5 pieces were being given for \$4.75, and what could withstand that argument?

It is true that the abuses charged against the yellow store have attached themselves to establishments not in that class. There are single line merchants who have a heavy account to answer for, made up of these particulars. But the fact remains that the yellow stores are the most inveterate and conspicuous offenders, and that their notorious success is founded largely upon economies resulting from these abuses. With any legitimate cheapening no sensible man can quarrel. Rather should we honor the men who have, by mercantile genius, made it possible to sell \$2 worth of goods on the margin formerly required for \$1 worth. That is in the line of industrial evolution, which constantly makes for greater efficiency in every part of the industrial mechanism. But when cheapness is effected, not through greater efficacy but through longer hours, harder labor and inferior workers, that is not evolution; that is reversion of type, a sort of going backwards and downwards. It may be urged that the \$3 a week clerk takes the place of the \$6 one, and the public gets the saving, but that view is based on the assumption that the cheap clerk does the same work equally well, a thing manifestly impossible. In the one case there is more or less special knowledge and interest in the consumer's wants; in the other, the specialized ability to rap for the cash girl and utter the mechanical query, "Take it with you, or have it sent?" You can't think on \$3 a week and pay 60 cents of it for car fare. I have heard an apology for the yellow merchant on the ground that no individual is responsible for these conditions, but a great impersonal tendency which it would be folly to resist. "A man must meet competition in order to succeed." It is of a piece with the fallacy, "A man must live."

The objection is urged against department stores that they cause a great loss in real estate through the extinction of the numerous small dealers. Whole districts have been changed from prosperous centers of retail trade to groups of empty stores. But the loss is in a measure compensated for by the enhanced values of real estate in the central districts. Certain holders of realty have lost; others have gained. The values have shifted; such shifting has always gone on, notably in the case of the value of water fronts in river towns. It is likely, however, that the loss has fallen on a number of small

holders, while the gain has accrued to a few large ones. Then, too, there is the congestion of traffic and of transportation in the down town quarters due, in part, to the growth of department stores. This disadvantage is being met by improved methods of transportation, underground and elevated roads.

As a direct result of the department store success, a multitude of small dealers have been driven from business and others are passing—many of the former are now employes of the department store. The transformation of a contented, independent shop keeper into a disgruntled clerk or floor walker is not a distinct benefit to the moral tone of the community, but in time an adjustment will take place. The president of the sugar trust recently proclaimed that in manufacturing the individual must go. As for merchandising, that process has already begun. It would probably be less painful to the individual if he could see that his elimination is for the benefit of the community, and not in such a great degree for the benefit of those engaged in the eliminating process. The proprietor of a department store in Chicago testified in 1895 before a committee appointed by the legislature, that all the capital invested in his business employing 2,000 people, was the original \$5,000 and the subsequent profits thereupon. Another firm testified at the same time that their net profits for the year were 50 per cent

on a capitalization of \$700,000. These were stores of the yellow type. No conservative, legitimate department store at that time, I venture to say, could show such earnings. The latter of the two yellow stores referred to was notoriously a place given over to the sale of shoddy goods; vile things, at vile prices.

(To be continued.)

**Connecticut.**

F. T. Bidwell will open a jewelry store in Bradstreet's block, Thomaston.

The police of Hartford have captured the burglar wanted for the job at M. Garfinkel's jewelry store.

Wilbur F. Rogers, of C. Rogers & Bros., Meriden, announces that he will not accept the re-nomination for Alderman of that city.

The Shelton factory of the International Silver Co. was so pressed with orders as to render it necessary for the works to run half a day on Thanksgiving day, something not done before in the history of the factory.

Mrs. Valeria Terry, widow of the late James Terry, of Terryville, whose grandfather, Eli Terry, the clockmaker, founded the village, died after a lingering illness at the home of her sister-in-law, Mrs. E. T. Richardson, in Bristol, last Wednesday morning.

Additional details of the organization of

the new electric clock company, in Bristol, are at hand. It is proposed to capitalize the company for \$150,000. The Bristol people are asked to subscribe for the entire issue of the preferred stock, \$50,000. The industry when in working order will, it is said, give employment to 150 hands.

Prentice Lewis died at his home in South Windham, Nov. 29, aged 71 years. Mr. Lewis was a native of Groton. In youth he learned the jewelers' trade in Central Village. He went to live in South Windham about 40 years ago, where he carried on the jewelry business, coupling with it the repairing of musical instruments, until about 20 years ago.

Superintendent Hobson, of the Barbour Silver Co., Hartford, a branch of the International Silver Co., was in Meriden, last Wednesday, to look over the old Meriden Silver Plate Co.'s factory where the Barbour plant is to locate. It is the purpose of the International officials to take advantage of the January shut down to move the Hartford business to Meriden. No unnecessary delay will occur, as the company's prospects for business are exceedingly good.

Mrs. Wm. Schlechter, of Easton, Pa., mother of G. A. Schlechter, jeweler, Reading, Pa., died last week, aged 81 years. Mrs. Schlechter was a well known and highly respected citizen of Easton.

**CROWN 14 K  
FILLED CASES**



**GUARANTEED  
FOR  
25 YEARS**

**Merit**

counts when money is plentiful. Good times call for the best quality of merchandise. To the watch buyer of to-day, quality and style are as much of a consideration as price.

**All Three to Suit**

is the sale-making consideration of

**Crown 14 K. and Lion 10 K.  
Gold-Filled Cases,**

the best built and best wearing watch cases in the market. Notwithstanding **Extra Merit** they cost no more than other makes of filled cases.

**Sold by All Jobbers.**

**LION 10 K  
FILLED CASES**



**GUARANTEED  
FOR  
20 YEARS**

**The Latest Patents.**

ISSUE OF NOV. 28, 1899.

**637,876. CLOCK.** ALMERON M. LANE, Meriden, Conn. Filed April 16, 1897. Serial No. 632,454. (No model.)

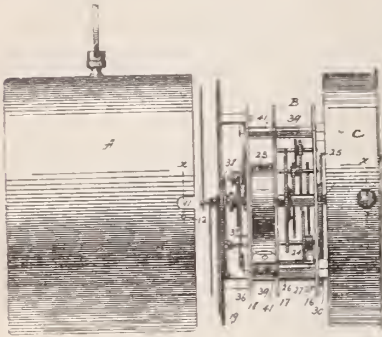

**637,955. PHOROMETER.** JOHN F. BYINGTON, Battle Creek, Mich. Filed July 2, 1898. Serial No. 682,328. (No model.)

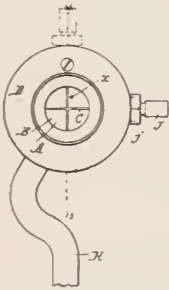

A transformer for phorometers having a lens and an opaque shade, said shade having a sight disposed in a straight line crossing the optical center of the lens, whereby a flame viewed through it appears to be transformed and presents to the

**JULES J. LINTZ,**

**Watch and Chronometer Maker**

**FOR THE TRADE.**

Two Diplomas and First Prizes for Scientific Workmanship.

108 Fulton Street, New York.

Downing Bldg., Room 1019.

Repairing of Fine and Complicated Watches Pocket and Marine Chronometers.

All kinds of New Pieces made to order and adjusted.

eye an image corresponding to the shape of the sight.

**638,018. TIME LAMPLIGHTER.** ARTHUR JOHNSON, Ipswich, Mass. Filed May 2, 1899. Serial No. 715,343. (No model.)

**638,160. ELECTRIC CLOCK.** HJALMAR E.

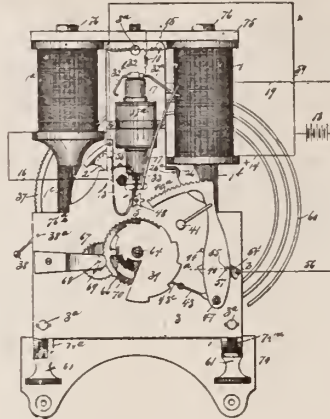

ANDERSSON, Stockholm, Sweden. Filed Feb. 16, 1899. Serial No. 705,711. (No model.)

**DESIGN 31,883. EYEGLASS GUARD.** MAX W. KAUFMANN, New York, N. Y., assignor to L. W. Levy & Co., same place. Filed Aug.



3, 1899. Serial No. 726,054. Term of patent 14 years.

**TRADE-MARK 33,806. SPECTACLES AND SPECTACLE TEMPLES.** SIEGFRIED G. MARSHUTZ, Los Angeles, Cal. Filed Nov. 6, 1899.

**AUROCONE**

*Essential feature.* The word "Aurocone." Used since Nov. 25, 1897.

**TRADE-MARK 33,807. PRECIOUS STONES AND SEMIPRECIOUS STONES.** CHAS. F. WOOD & Co., New York, N. Y. Filed Nov. 1, 1899.

**T**

*Essential feature.* The letter "T." Used since June 1, 1899.

**THE LEDOS MFG. CO.,**

MANUFACTURERS OF

**Watch Case Materials,**

Crowns, Pendants, Bows, Solders, Springs, Findings, Etc.,

34-36 PEARL ST., NEWARK, N. J.

**TRADE-MARK 33,808. EARTHEN WARE, CHINA, PORCELAIN AND PARIAN.** PERCY SHELLEY, Longton, England. Filed May 12, 1899.

**FOLEY**

*Essential feature.* The word "Foley." Used since Jan. 1, 1863.

**EXPIRED PATENTS.**

[Recently expired patents of interest to the jewelry trade. Reported especially for THE JEWELERS' CIRCULAR by R. W. Bishop, Patent Attorney, 728 Fifth St., N. E., Washington, D. C., who will furnish complete copies of patents at the rate of 10 cents each.]

Issued Dec. 5, 1882.

**268,388. CRUET.** W. A. COLLINS, Madison, Ind.

**268,454. SHOW CASE FOR JEWELRY.** LEONHARDT BREIDENSTEIN, San Francisco, Cal.

**268,469. INLAID WORK.** W. C. EDGE, Newark, N. J.

**268,486. PROCESS OF FORMING ORNAMENTAL DESIGNS ON METAL.** T. N. HENCHY and E. P. FEICHER, Northampton, Mass., assignor of one-half to E. E. Wood, same place.

**268,524. PENDULUM ADJUSTMENT.** Z. R. NILES, Oneida, N. Y.

**268,687. PLATED WIRE.** KAUFMANN KAUFMANN, New York, N. Y.

**268,713. WATCH CROWN.** THEO. MUELLER, Philadelphia, Pa.

**268,714. WATCH PENDANT.** THEO. MUELLER, Philadelphia, Pa.

*Designs issued Dec. 6, 1892, for 7 years.*

**22,030 and 22,031. SPOONS.** J. S. RATHBONE, Mystic, Conn.

**22,033. SPOON.** G. A. SCHLECHTER, Reading, Pa.

**22,034. SPOON.** W. C. SOMMER, Springfield, Ill.

**22,035. SPOON.** W. A. BIGLER, Chicago, Ill.

**22,039. PURSE.** MAX SCHEUER, New York, N. Y.

*Designs issued June 2, 1896, for 3 1-2 years.*

**25,553. BADGE.** L. A. BROWN, St. Louis, Mo.

**25,554. BADGE.** J. S. BLINN, New Haven, Conn., assignor to the Scovill Mfg. Co., Waterbury, Conn.

**25,558. SPOON.** P. B. NOYES, Niagara Falls, N. Y., assignor to the Oneida Community, Limited, Kenwood, N. Y.

**25,568. BRUSHBACK.** H. A. WEILMAN, Philadelphia, Pa.

**Newark.**

George Grimsey, of Nutley, is looking for a satchel which he left on a car on his return home from Newark Thursday night. He is a diamond setter, and went to Newark Nov. 30 to work. When he started for home he took a lot of gold and stones which he expected to set at home, and rode home on a trolley car. The contents of the bag which he left in the car are valued at \$1,000. He had 60 gold rings and a number of diamonds, rubies and pearls. No trace has as yet been obtained of the bag.

Arthur Kennedy, Carlton Shepard and William Cornell, whose ages range from 18 to 22 years, and who say they reside in Mt. Vernon, N. Y., were arrested on the night of Nov. 27 charged with attempting to work a swindling game. They were discharged by Judge Lambert next morning for lack of evidence. The prisoners had a quantity of cheap watches and paste diamonds, together with some alleged bogus pawn tickets, representing diamond rings pawned for \$50. The police thought that the boys had been selling the alleged bogus pawn tickets, but the detectives could not find that the suspects had offered for sale anything but the cheap jewelry.

**JULES JÜRGENSEN,**

COPENHAGEN,

Plain and Complicated **WATCHES AND CHRONOMETERS,**

Are the leading production of their kind in the world.

SOLE AGENTS

**Schulz & Rudolph,**

Importers and Cutters of Diamonds and Other Precious Stones....

28 JOHN and 65 NASSAU ST., NEW YORK.



## PRACTICAL COURSE IN ADJUSTING.

### COMPRISING

*a review of the laws governing the motion of the balance and balance spring in watches and chronometers, and application of the principles deduced therefrom in the correction of variations of rate arising from want of isochronism, change of position and variation of temperature.*

### ELUCIDATED AND DEMONSTRATED BY

*original experimental researches in the actual problem, never before published, showing the causes that are operative in the variation of rate and leading to correct remedies.*

BY THEO. GRIBI.

Copyright by Theo. Gribi; assigned to THE JEWELERS' CIRCULAR PUB. CO.

[COMMENCED IN ISSUE OF FEB. 1, 1899. PART XXII.]

## CHAPTER IV.

*(Continuation of Mechanical Effects.)*

Another of the essential points is the size and form of the balance pivots and their proper play. The diameter of a balance pivot should not be over 0.12 of a millimeter in an 18 size watch and not above 0.11 millimeter in one of 16 size. They should be perfectly cylindrical for a length a little more than the thickness of the jewels and the space between the latter and the endstones. Both upper and lower ones should be of the same size and the ends should never be made perfectly flat; yet neither too pointed. It is absurd to want to adjust watches by flattening the ends of the pivots with a view of equalizing the arcs of motion in vertical and horizontal positions. In the first place, it cannot be done by flattening the pivots, as the friction will always be much greater on the circumference than on the ends, and in the second place, if it could be done it would be no advantage, but rather a disadvantage, as we shall see hereafter. The end shake should be only sufficient to insure perfect freedom and all three mobiles, balance, pallet arbor and wheel should have the same amount. The side shake of the balance pivots should not be more than 0.01 millimeter. If it is more than that and the jewels are thin, as is the case in many fine watches, the oil will run out of the holes and the pivots run dry and cut in a little while.

In this connection I would state that it is my opinion, founded on long experience, that many makers of fine watches use balance jewels that are altogether too thin. They do not retain the oil so well. This is the case particularly when the space between end stone and top of jewel is too great, and, as stated just now, when, in addition, the side shake of the pivot is greater than it ought to be. It is difficult to understand why they should use such thin jewels and make the sides of the holes olive shaped at that, which reduces the surface in contact almost to a knife edge. It certainly cannot be that they do it with a view to reducing the friction in vertical posi-

tions and with a full knowledge of the law of friction, viz.: that it is independent of the surfaces in contact, the pressure remaining the same. What they really do is to limit the wear and tear of friction to a narrower surface. After all that has been said on the subject of friction there still seems to exist a confusion in the minds of many between friction as a resistance to motion and the work done by friction in the wear and tear of the surfaces in contact. While the former is independent of the surfaces in contact the latter is inversely proportional to them, the pressure remaining the same, *i. e.*, the work done by friction in the wear and tear of the rubbing surfaces is greater when the extent of the latter is reduced. Hence, thin jewels will cut the pivots quicker than thicker ones, and this will be the case particularly when the oil runs away from the pivots. It is a pity that more thought is not given to this matter in the making of balance jewels, which as to form and finish are often real gems of art, but which, owing to their being too thin, are worse than useless for the purpose intended. Of course, the repairer has to take things as they come sometimes without being able to alter them, and to him these reflections may be of little practical benefit except to enable him to connect cause and effect when results are unsatisfactory.

Attention must be paid to the end stones. They should not be too far away from the jewels; 0.03 to 0.04 of a millimeter should be the maximum, and their flat surfaces should be perpendicular to the axis of the balance. If this is not the case differences of rate between "dial up" and "dial down" will be the result.

The poising of the balance should be perfect and should be done on the poising tool. Not only is this the best we can do, but the idea of poising the balance from differences observed in the rate of a watch in opposite vertical positions as practiced by some and recommended by M. Lossier<sup>11</sup> is fallacious. Position error is no proof that the balance is out of poise (11, a and b and 12). We can indeed, to some extent, correct position error by putting the balance out of poise; this, however, only corrects the error in the highest and lowest arcs; in the middle ones between 360° and 450° it would still exist, and these are just the arcs of motion the balance generally has in vertical positions.

It may be a matter of surprise to some of my readers that I have not before alluded to the poise, or want of poise, of the lever as one of the factors in the variation of the rate of watches. The fact is that want of poise in the lever, if sufficient to influence the rate at all, can do so only in the vertical positions; in the horizontal positions it is entirely without effect and can therefore not be considered as one of the factors disturbing the isochronism of the spring; not only that, but I am sure that an attempt at poising it, if a heavy counterpoise is required, such as is frequently found in watches, is

(11) Étude sur la théorie du réglage, p. 112.

more disastrous through the increased friction caused by the increase of the weight of the lever, for in no part of the watch is the addition or diminution of the weight of the moving parts so important as in the latter. There was a time when the poise of the lever was considered an essential condition by the manufacturers. They applied a heavy counterpoise; often, when required, as in the case of the long forks, at a great distance from the center of motion, unconscious, apparently, of the fact that they were surcharging the already small enough force exerted at the circumference of the scapewheel by giving it more work to do. It became a matter of fashion, the artistic taste taking advantage of it in the production of fanciful and fantastic designs. We have unlearned all this. In the best watches made to-day the counterpoise is dropped entirely, experience having shown that lightness in the lever is of greater importance than

its equipoise. It should be observed that in a lever reduced to its least weight consistent with a proper firmness, and particularly in the case of short forks, which are now almost universal, the want of poise can never be very considerable. Taking an ordinary practical example, M. Lossier, in the work before quoted, page 49, has shown that a want of poise in the lever, such as may be found in a well-constructed watch, would cause a variation of rate between opposite vertical positions of not more than 0.11 seconds in 24 hours, a quantity entirely neglectable. We may therefore dismiss this factor, as to its influence in the work of adjusting, with the sole recommendation to the workman to look to the freedom and the lightness of the lever rather, and to secure the proper amount of draw on the locking surface of the pallets.

(To be continued.)

### Workshop Notes.

**To Amalgamate the Zinc for Electric Batteries.**—Dissolve two parts of mercury in one part of aqua regia. This accomplished, add five parts of hydrochloric acid. This solution is made warm. It suffices to dip the zinc to be amalgamated into this liquid only for a few seconds.

**Gold Varnish for Copper.**—Alcohol (95%), 1 liter; seed-lac, 170 grammes; pulverized glass, 100 grammes; melted amber, 60 grammes; dragon's blood, 30 grammes; gamboge, 5 grammes; turmeric, 2 grammes; boracic acid, 3 grammes; macerate during five to six days, then filter.

**Jewelers' Glue Cement.**—Dissolve in a water bath 50 grammes of fish glue in a little 95% alcohol, adding four grammes of gum ammoniac. On the other hand dissolve 2 grammes of mastic in 10 grammes of alcohol. Mix these two solutions and preserve in a well corked flask. For use it suffices to soften it on the water bath.

**Alloys for Jewelry Matrices.**—Lead, 90 parts; antimony, 10 parts; or, lead, 87.5 parts; antimony, 12 parts; arsenic, 0.5 parts; or, copper, 35 parts; tin, 35 parts; bismuth, 30 parts; or, lead, 60 parts; zinc, 17 parts; tin, 13 parts; antimony, 10 parts; or, lead, 48 parts; tin, 47 parts; antimony, 5 parts; or, lead, 60 parts; tin, 37 parts; antimony, 3 parts.

**Silvering Metals Without Battery.**—Dissolve 10 grammes of nitrate silver in 50 grammes of distilled water. On the other hand, dissolve 30 grammes of cyanide of

potassium in 60 grammes of distilled water. Mix all, stir for a quarter of an hour, and add 1 gramme of mercury. For use, make a paste with Paris white, adding for the silvering 10% of finely powdered cream of tartar.

**Bronze Powders.**—Gold bronze is a mixture of equal parts of oxide of tin and sulphur, which are heated for some time in an earthen retort. Silver bronze is a mixture of equal parts of bismuth, tin and mercury, which are fused in a crucible, adding the mercury only when the tin and the bismuth are in fusion. Next reduce to a very fine powder. To apply these bronzes, white of egg, gum arabic or varnish is used. It is preferable to apply them dry upon one of the above named mediums serving as size, than to mix them with the liquids themselves, for in the latter case their luster is impaired.

**White-Pickling Alloyed Silver.**—To increase the white color of silver in copper-silver alloys by pickling the following processes are in use: The articles produced from alloyed silver are sometimes covered with a thin, black film of cupric oxide, if they had to be annealed during the working, and sometimes they do not possess, although made bright by filing, scraping, etc., a pure silver color, but have more of a reddish-white appearance, according to the percentage of copper in the alloy. To impart to silver objects the handsome appearance peculiar to fine silver, the copper contained in the alloy should be removed by the aid of a solvent from the exterior surface of the articles, thus causing the remaining very thin film of fine silver to

cover up the true color of the alloy. In order to enable the solvent or pickle to act thoroughly upon the copper the latter should be oxidized by annealing, and for this reason the articles, which come bright from the working, should be moderately annealed for a short time before the pickling so as to acquire the said blackish coating of cupric oxide. For the pickle an acid liquid is employed capable of dissolving the cupric oxide, but not the silver. Various compositions are suitable for this purpose. Generally a solution of 15 grammes of finely powdered tartar and 30 grammes of cooking salt in one-half to three-quarters liter of water is employed, in which solution, after it has been heated in a copper vessel to a boil, the objects are left until they appear bright upon removal. The time required varies according to the fineness of the silver. Very effective for blanching silver is also diluted sulphuric acid, prepared from sulphuric acid, 20 grammes, and water, 1 liter. A solution of strong action is obtained by dissolving 50 grammes of potassium bisulphate in one-half liter of water, which solution need not be heated before use. A single pickling does not give the silver goods the desired whiteness. They are, therefore, rubbed with fine sand, or if the surface is not smooth, but ornamented, with a brass wire scratch brush, then they are annealed again and the pickling repeated. Frequently the annealing and pickling are repeated even for the third time. Works which are to remain matt are covered before the second pickle with a paste of water and potash, dried, annealed and cooled in water.

## THE TRUE BLUE

Beaded Label Watch Glasses,

MADE IN

FRANCE.

ASK YOUR JOBBER FOR THEM.

SUSSFELD, LORSCH & CO.,

21 Rue de L'Echiquier, PARIS.

LORSCH BUILDING,  
37 & 39 Maiden Lane, NEW YORK.



## WATCH GLASSES

BEAR THE  
BEADED LABEL.

BEWARE OF  
IMITATIONS.

THE GENUINE  
ARE LABELED



FRANCE.

## MATTERS IN JEWELRY STOREKEEPING.

That this department shall prove mutually beneficial to our readers, it is desirable that the members of the trade generally communicate with THE CIRCULAR regarding any advantageous device or plan that they are utilizing in connection with their business.

### Best Dressed Windows Among the Retail Jewelers.

#### Series II. No. XV.

*NOTE:—We inaugurated with the issue of May 3, 1899, the second series of characteristic retail jewelers' windows. The first series consisted of illustrations and descriptions of more than 100 different displays, extending over a period of 8 years. We desire any jeweler who thinks his window is interesting or calculated to serve as a lesson to his brother jewelers, to send to us a photograph of such window for illustration under this department.*



ORIGINAL IDEA FOR A JEWELER'S CHRISTMAS  
HOLIDAY WINDOW.

IN the above original design for a retail jeweler's Christmas holiday window, it will be seen that the salient feature is the cross. This cross is composed of bands of broad silk or satin ribbon suspended from holly wreaths. At each end of the cross is a rosette. Attached to the cross are diamond pins, brooches, and other jewelry pieces, while hanging from the lower extremity of the cross are chains which tend to hold the ribbon taut and in place. Such an arrangement would make a bright, cheerful as well as timely and suggestive window exhibit, and it is entirely practicable.

#### Mirrors in Show Windows.

EFFECTIVE results in show windows are often produced by the aid of mirrors, doubling the exhibit, or even seeming indefinitely to extend it. A curious illustration of the effectiveness in such use was shown in a window of a big toy store. Ranged in companies and battalions, following one another upon a foot-wide strip of glass raised above the floor of the window and extending along close to the window in front, and along the entire width of it, was a long column

of toy soldiers, marching, or seeming to march, the figures being all in marching attitudes. At the side of the window was a mirror standing vertically, but running back from the front at an angle slightly acute. Seen from the sidewalk and at a little distance from the window the reflection in the mirror of the marching column of soldiers had the appearance of a continuation of it, the column turning at the mirror, at a slight angle from the course of its march along the glass, the effect being produced by the angle at which the mirror was set.—*The Sun.*

#### Jewelers' Ideas and Schemes.

J. N. Brittain, 22 Geary St., San Francisco, Cal., sends out a card in which are punched a series of holes showing sizes of rings. The card enables the buyer to determine the proper size of ring by merely inserting the finger in the proper hole.

R. J. Riles, Jacksonville, Fla., displays a fine conductor's lantern of which he will make a present to the most popular conductor on the Plant System. Every purchaser of goods at his store, even to the small amount of 10 cents, can cast one vote. The conductor receiving the highest number of votes will get the lantern.

#### Retailers' Christmas Souvenirs.

A neat and handy souvenir presented with Christmas greeting to the patrons of Wm. Glover, Jr., retail jeweler, Hazleton, Pa., is an eight-page booklet with a pretty embossed cover. In it are to be found lists of suitable presents under the head of "What to Buy for Ladies, for Gentlemen, for Children and for the Home." The book will, no doubt, prove useful to Mr. Glover's customers in a way that will be advantageous to himself.

A chic little souvenir issued by Thos. D. Ladson, 1115 F St., N. W., Washington, D. C., is a 3x3½ inch book entitled "A Jeweled Sandwich." It contains information for the jeweler's customers on many topics of interest, among which is a list of the wedding anniversaries, a table of the great diamonds of the world, a table of birth month stones and their meaning, as well as the birth month poem, the superstitious sentiments of gems, together with a summary of the lines adapted as holiday gifts. One page is devoted to old English silver, in which an invitation is extended to the public to avail themselves of Mr. Ladson's records to learn the date of old pieces.

The 20th Century Christmas Messenger, under which style catalogue No. 15, of Ambrose Kent & Sons, Toronto, Can., is sent to the public, is a very finely illustrated, 36-page pamphlet of large size. Eight pages are devoted to half-tone illustrations of their various silver novelties; one page to wood cuts of Masonic and other emblems; three pages to sterling silver, hollow ware and cut glass, while space proportionate to their importance is given to rings, chains, silver plate, clocks, spoons and other lines. The diamond jewelry appears illustrated in colors, gold and white appearing on a black ground, and giving an excellent idea of the articles. On the back cover of the catalogue are some interior and exterior views of the firm's jewelry factory, engraving department, optical and other rooms, etc., at 156 Yonge St., and 5 and 7 Richmond St., W., Toronto, Can.

W. F. Main, Iowa City, Ia., has employed Louis E. Lyon to oversee the purchase and erection of the machinery for his East Iowa City jewelry factory and such other work as is necessary to prepare the factory for operation.

# BRADLEY & HUBBARD MFG. CO.

Have produced for this season's trade the finest line of goods ever offered.

## Art Metal Goods,

PITCHERS, VASES, CANDELABRAS, FIGURES, BUSTS, TABLES, ETC.....

## Reception Lamps

WITH THE CELEBRATED "B. & H." and B. & H. RADIANT BURNERS. NEW AND ORIGINAL DESIGNS. HANDSOME AND EXCLUSIVE FINISHES.

*Dealers are cordially invited to inspect the line of Samples at our SALESROOMS.*

NEW YORK: 26 Park Place to 21 Barclay Street.

BOSTON: 160 Congress Street.

CHICAGO: 131 Wabash Avenue.

PHILADELPHIA: 714 Betz Building.

FACTORIES and OFFICES: MERIDEN, CONN.

## SILVER MEDAL AWARDED

... BY ...

NATIONAL EXPORT EXPOSITION, Philadelphia,

... TO ...



**C. F. Rumpp & Sons,** Established 1850.

PHILADELPHIA, FOR

**HAND-CARVED LEATHER GOODS.**

SEND FOR ILLUSTRATED CATALOGUE.

These well-known Razors, the quality of which is warranted, possess this great advantage, that they may be used for ten years before they require actual sharpening. Before using them it is necessary to rub them on good leather strop. Le Coultre's Strops (to be had with the Razors) should be used in preference to others.

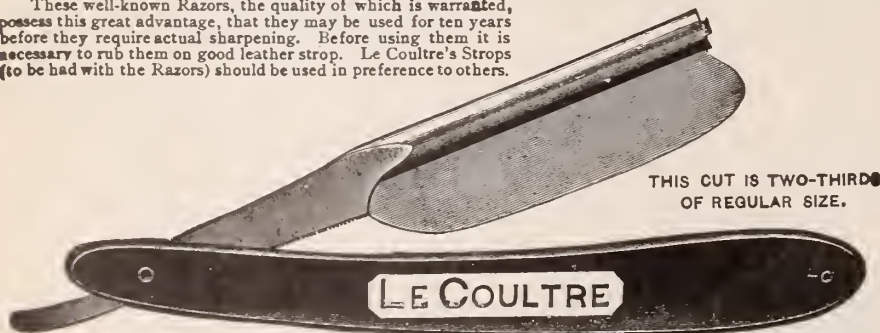

"SPECIAL"—Single Razors for Jewelers' Travelers at trade price.

## MATHEY BROS., MATHEZ & CO.

Send for Price List.

Sole Agents, 21 & 23 MAIDEN LANE, N. Y.



GOLD SHELL.

"Buy direct from the manufacturer and get all that is coming to you."

SEND FOR OUR "HOT CATALOGUE, CONTAINING COLD FACTS AND PRETTY PICTURES."

**CLARK & COOMBS,**

86 WEST EXCHANGE ST.,

PROVIDENCE, R. I.

WE ARE HEADQUARTERS FOR.....

**Gold Shell Rings...**

## THE SWAN FOUNTAIN PEN.

Reputation World Wide. Made upon Distinct Principles. Is a Compressed Air Pump. Simply Wet the Insides to Provoke an Energy.

**W. W. Stewart,** Inventor and Patentee.

A variety of Styles and Prices

3 Sizes Safety Swans.

3 Sizes Self-filling Swans.

3 Sizes Adjustable Feed Swans.

**MABIE, TODD & BARD,**  
NEW YORK AND LONDON.

**HENRY C. HASKELL,**

11 Maiden Lane, N. Y.,

has a special department for Jewelry repairing of all kinds. Prompt attention. Prices right. Exclusive Design Plates sent dealers upon request.

**DR. KNOWLES'**

...PRIVATE COURSE IN...

## Optometry.

SPECIAL RATES IN THE CORRESPONDENCE DEPARTMENT.

"EYE DEFECTS,"

A New Book, in cloth, Price, \$1.00.

For terms and important particulars, write to **R. H. KNOWLES, M. D.,** 11 John Street, New York.



**FERD. FUCHS & BROS.,**  
**SILVERSMITHS,**  
MAKERS OF STERLING SILVERWARE,  
34 East 29th St., - New York.

**WOOD & HUGHES,**  
Sterling Silverware Manufacturers,  
FINE PLATED WARE,  
No. 24 John Street, - New York.





**THE RAMBLER'S NOTES.**

WHAT THE RAMBLER SAW AND HEARD AMONG THE DEALERS IN ART POTTERY, CUT GLASS, BRONZES, ETC.

**NOVELTIES IN SICILIAN GLASS.**  
 TO their line of Sicilian glass, described in this column some months ago, Wicke & Co., 32-36 Park Pl., New York, the agents for this ware, have recently received many additions. The new pieces are principally small articles of utility and ornament, such as bon bon baskets, sugar bowls, pitchers and flower vases, and many new effects in coloring are to be found on them. Of these colorings, perhaps the simplest, yet most attractive, is the plain milk white shading into a golden yellow, which produces a slight opalescent effect that greatly enhances the beauty of the small, graceful flower vase so treated.

**WINDOW BOXES IN GERMAN FAIENCE.**  
 WINDOW boxes of German faience are among the novelties shown by C. L. Dwenger, 35 Park Pl., New York, and as these pieces are suitable for holding plants and ferns in places where it is impossible to use a jardiniere, success has already crowned their introduction. In decorations they show odd effects in deep colorings with conventional flower designs of bright hues, and in this they are similar to a large line of vases now to be seen in the same ware as these boxes. The boxes are in diversified rectangular shapes and in several sizes.

**"WAVE CREST" AS A HOLIDAY LINE.**  
 THE holiday season always brings out the greatest demand for the C. F. Monroe Co.'s beautiful productions in "Wave Crest" ware, as this line is composed essentially of articles suitable for presentation purposes. No more desirable pieces for the jewelers' Christmas stock can be found than the cigar jars, tobacco boxes, cigarette cabinets, playing card cases and similar articles now shown at the company's New York salesrooms, 23 Barclay St., and this is also true of the handkerchief, glove and trinket boxes, comb and brush trays, toilet articles and other pieces of a more feminine character which abound in this ware. The new vases and footed jardiniere introduced this season have also become very popular.

DINNER CALLS OF VARIOUS KINDS.

**M**ONTAGUE F. HARRIS, of Harris & Harrington, returns to-day from Europe, where he has been arranging for the firm's Spring lines as well as for the novelties yet to be received this season. Among the many articles shown at this firm's warerooms, 32 Vesey St., New York, that are selling especially well during this holiday season, are dinner calls of various kinds. Many new styles are now shown, having carved oak or mahogany stands from which are suspended two, four or eight tubular chimes. Bar chimes with similar stands are also selling well.

THE RAMBLER.

**John and the Clock.**

[From Harper's Round Table.]

**J**OHAN MULDOON, an Irishman, had been hired as a general standabout and valet to a certain irascible old gentleman. Three days after his debut at the gentleman's house a friend met him on the street and asked him how he liked his new job.

"'Twas bad," said John; "that bad I c'u'dn't tell ye. Oi'm bounced, an' all fer doin' me juty!"

In response to a request for particulars, John told the following story of his unjust discharge:

"Sure," said he, "'twas this-a-way. Wid all me other num'rous juties Oi hed to clane up and doost the master's lib'ry, wid all the books and statoary and what not. Now the master had an auld thing av a clock a'hangin' on the wall, and he says, says he, 'John, be careful wid th' clock,' an' Oi med up me moind that no'ut sh'uld harrum the clock, 'fer,' says Oi, 'me place de-pinds on th' clock.' An' th' next mornin,' when Oi was a-doostin' th' clock—takin' all proper care—what sh'uld happen but a measily little burd comes and hops on th' top av th' clock, as impident as you plaze.

"'Ho, ho!' says Oi, 'it's not there ye'll shtay fer long, ye meddlin' chippee!"

"'But he niver shtirred at all, at all, fer all me talk.

"'Get off!' says Oi.

"'Cuck-oo!' says he, as quick and sassy as you plaze.

"'Bur-r-r-r-r-roo!' says Oi (not loikin' to be outdone in blackguardin'), and thin Oi basted him wid the doost rag.

"The next dey I was tould me sarvices was no longer required.

"An' that's how the rich treats the poor man fer doin' his juty by them fair and square."

The German Emperor has a passion for glass, and possesses some very rare and antique specimens. He has recently purchased a lovely dinner service in finest Salviati ware. The decanters are reproductions from ancient designs.

Dainty and precious and quite unique is Mrs. Sheldon's diamond rapier, formed of big and beautiful old mine gems set in a crest of smaller stones.

**OLD BRITISH POTTERY MARKS**

HOW TO IDENTIFY 17TH CENTURY AND 18TH CENTURY CHINA AND PORCELAIN.

[Commenced in issue of Nov. 15.]

**Swansea Ware** (1802).—The ordinary mark of the factory was the word "Swansea" stenciled in red or impressed. The trident alone, or in connection with the name of the factory (Figs. 35 and 36), de-



FIG. 35.



FIG. 36.

notes, according to Mr. Dillwyn's explanation, a supposed improvement which was ultimately not found to answer.

**Shropshire Pottery.**—The specimens are not always marked, but frequently found stamped with the word "Salopian," either alone or in connection with a painted crescent. The letter S in blue under the glaze (Fig. 37), sometimes accompan-



FIG. 37.



FIG. 38.



FIG. 39.



FIG. 40.

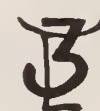

FIG. 41.



FIG. 42.

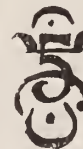

FIG. 43.



FIG. 44.



FIG. 45.



FIG. 46.



FIG. 47.



FIG. 48.

\*Adapted from the Pottery Gazette.

# THE LADY RACINE

IS THE

## Best Chatelaine Watch

10 Line,  
11 Line,  
12 Line,  
13 Line,  
Hunting or  
Open Face,



Nickel,  
Steel,  
Silver,  
Enameled,  
Gold,

**In new and tasty designs.**

Can be ordered from all Reliable Jobbers.

# The "Bryant" Rings.

ARE KNOWN TO THE JEWELER'S CUSTOMERS AS THEY ARE TO THE JEWELER, HAVING FOR 50 YEARS OCCUPIED THE PROUD POSITION OF "THE BEST."



THE "BRYANT" MARK IS ACKNOWLEDGED TO BE A GUARANTEE OF QUALITY, STYLE AND FINISH.

GOODS SENT ON APPROVAL TO RESPONSIBLE DEALERS.

Our new Fall line comprises a profusion of new designs.

**M. B. Bryant & Co.,**  
10 Maiden Lane, New York.

ied by a small cross, a butterfly, or crossed swords (Fig. 38), is another Caughley mark. Specimens marked with a series of Arabic numerals from 1 to 8 (Fig. 39 to 46), a sort of Oriental mark (Fig. 47), an arrow head (Fig. 48), and a birdbolt (Fig. 49), are likewise considered as of Turner's manufacture.

**Coalport Ware (1750).**—Genuine and early marks of the Coalport factory are the words "Coalport," or C. Dale, the initials C., C. D. (Fig. 50), or C. B. D., in monogram (Fig. 51), a rose (Fig. 52). In tea sets generally only the sugar basin is marked. Later specimens bear the in-



FIG. 49.



FIG. 50.



FIG. 51.

scription "John Rose & Co., Colebrook Dale, 1850," and since 1861 a monogram (Fig. 53) in pink and gold is used, the cursive letters representing a C. and S.,



FIG. 52.

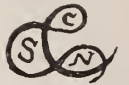

FIG. 53.

for Coalport and Salop. The Roman capitals within the loops are the initials of Caughley, Swansea and Nantgarw, incorporated with Coalport.

**Staffordshire Porcelain.**—Minton's porcelain is generally marked with the name of the firm indented on the ware. The earlier marks, impressed or painted in gold and colors, are given in Figs. 54, 55 and 56 (Minton's ermine mark).



FIG. 54.



FIG. 55.



FIG. 56.

Between 1800 and 1827 Spode's china was marked either with the name "SPODE," impressed or painted in blue, purple, or red, or "SPODE, FELSPAR PORCELAIN," "SPODE, STONE CHINA"; after 1833, until 1847, "COPELAND & GARRETT" in a circle within branches, surmounted or centered by a crown. Inscriptions like "NEW BLANCHE," "SAXON BLUE," &c., indicate certain improvements in paste or decoration. Two C.s interlaced and the name Copeland underneath is the mark since 1847.

(To be continued.)

Further details of the incorporation of the Sun Optical Mfg. Co., under the laws of the State of New Jersey, are as follows: The incorporation is for the purpose of manufacturing in Trenton, N. J., all kinds of optical goods, including spectacles, opera glasses, field glasses, microscopes, etc. The incorporators are George F. Applegate, with six shares; Freeman Leaming, with three shares, and Paul Lupke, with one. The stock will be divided into 500 shares of \$100 each. The business will be gone on a capital of \$1,000.

**WM. H. BALL & Co.,**

**Our Specialty:**

MANUFACTURING JEWELERS,

Anderson Building, 12-14-16 John St., N. Y.



**Everything in  
Gold Bracelets.**

Curb Bracelets, Bangle Bracelets, Fancy Stone Bracelets, Baby Esther Bracelets, Bracelet Mountings.

American  
Watch Case Co.,

**A.W.C.CO**

9-11-13 Maiden Lane,

Gill Building, New York.

**CROUCH & FITZGERALD,**

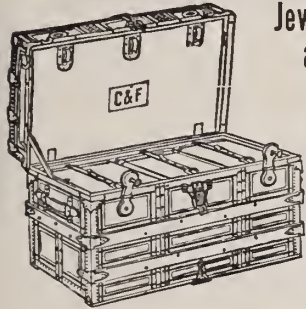

Jewelry Trunks  
and Cases,  
161  
Broadway,  
Bet. Cortlandt and  
Liberty Sts.  
688 B'way,  
723 6th Av.  
NEW YORK.

**J. R. WOOD & SONS,**  
21 MAIDEN LANE, NEW YORK.

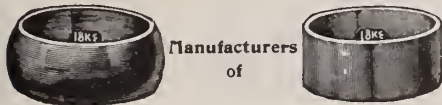

SEAMLESS PLAIN SOLID GOLD RINGS,  
Diamond Engraved Stone and Child's Rings,  
No Rings Stamped Different from Quality.  
Send for Catalogue and Price List.

Cash paid for old gold or silver or taken in trade. If allowance is not satisfactory, notify AT ONCE and will return in same condition as received.

**THE BASSETT JEWELRY CO.,**

Fine Gold-Filled Chains,  
Locketts and Gold Jewelry,

PROVIDENCE, R. I.

**JACOT & SON, IMPORTERS.**

**STELLA AND  
IDEAL  
MUSIC BOXES.**

39 UNION SQUARE, - N. Y.

**"By Using Our Goods Your Goods Will Sell."**

**We Always Lead**

With Something New and Artistic for Manufacturing  
Jewelers.

**OUR FINDINGS SPEAK FOR THEMSELVES**

Call or Send for Samples of

**OUR LATEST**

**And Keep Your Trade Guessing What You Will  
Show Them Next.**

We are now showing a handsome and complete line of

**MEDALLIONS AND EBONY MOUNTS.**

**HEIMBERGER & LIND,**

158 PINE ST., METCALF BUILDING, PROVIDENCE, R. I.

**KETCHAM & McDOUGALL,**

MANUFACTURERS OF

GOLD AND SILVER

**THIMBLES**

ESTABLISHED 1832.

**M&D**

TRADE-MARK.

And the improved

**Automatic Eye-Glass Reel.**



No. 140



Pat'd Nov. 30, '94

SEND FOR  
CATALOGUE C.

37 MAIDEN LANE,

NEW YORK.

**AIKIN, LAMBERT & CO.,**

MANUFACTURERS OF

FINE GOLD PENS, HOLDERS, PENCILS,  
TOOTH PICKS and NOVELTIES.

PAUL E. WIRT FOUNTAIN PENS, at new and lower prices . . .  
MERCANTILE FOUNTAIN PENS, guaranteed to give satisfaction.

Catalogues with terms and discounts furnished to the trade.

BRANCH, 103 STATE STREET, - - - CHICAGO.

19 MAIDEN LANE, NEW YORK.

**AIKIN-LAMBERT JEWELRY CO.,**

IMPORTERS OF

**DIAMONDS.**

JOBBER'S IN

**WATCHES, JEWELRY, CHAINS,  
NOVELTIES, ETC.**

LATEST DESIGNS.

LOWEST PRICES.

# CHAS. F. WOOD & CO., DIAMONDS

1 MAIDEN LANE, NEW YORK.

IMPORTERS AND CUTTERS.

## DIAMONDS.

LARGE ASSORTMENTS.

DESIRABLE SIZES.

ATTRACTIVE PRICES.

**R., L. & M. FRIEDLANDER,**

30 MAIDEN LANE, N. Y.

97 HATTON GARDEN, LONDON.

## HALL CLOCKS,

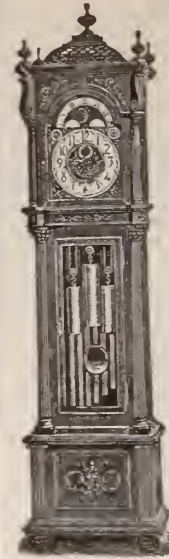

*Mantel Clocks,  
Traveling  
Clocks,  
Clock Sets,  
Regulators,  
Bronzes,  
Vases, Ivory  
Miniatures  
and Art Goods.*

Fall Line Now Ready.

**Harris & Harrington,**

32 and 34 VESEY ST., NEW YORK.

Sole Agents to the Trade for J. J. Elliott & Co., London.

Survival of the Fittest.

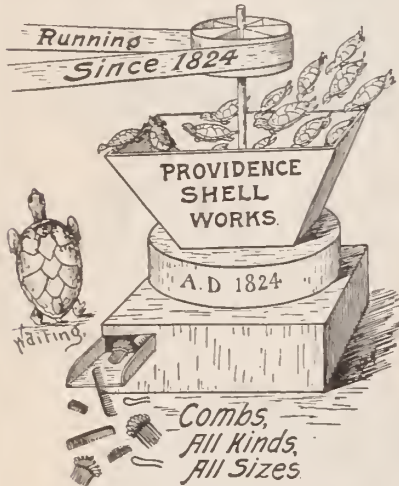

POTTER'S COMB FACTORY,  
PROVIDENCE, R. I.

We Grind for You,  
Send along your Work.

**W. C. A. WESTPHAL,**

WATCHMAKER,

41 Maiden Lane, NEW YORK.

Established 1892. Telephone, 3684 Cortlandt.

Estimates, Repairing, Adjusting of Chronometers, all  
Complicated Watches and Fine Time Pieces.

DEMAGNETIZING.

Watches made Non-Magnetic.

Fine Wheel and Pinion Cutting

## HOROLOGICAL DEPARTMENT,

BRADLEY POLYTECHNIC INSTITUTE,

PEORIA, ILLINOIS.

Largest and best watch school in America. We teach  
Watch Work, Jewelry, Engraving, Clock Work,  
Optics. (Formerly Parsons' Horological Institute.)  
Catalogue Free.



GOLD AND SILVER PENCILS,  
PENHOLDERS, &c.



FAIRCHILD & JOHNSON CO.

Office and Factory,  
220 FOURTH AVENUE, N. Y.

## L. LELONG & BRO.,

Gold and Silver

Southwest Corner of

HALSEY and MARSHALL STREETS,

NEWARK, N. J.

REFINERS,  
ASSAYERS and

SWEEP SMELTERS.

Sweepings a Specialty.

Horseshoe, Clover, Heart, Wishbone and Anchor.

THESE ARE A FEW OF THE THOUSAND  
DIFFERENT DESIGNS OF LUCKY BANGLES.

**S. & B. LEDERER CO.**

FACTORY: 100 STEWART STREET,  
PROVIDENCE, R. I.

New York Office, 11 John Street.

Chicago Office, 131 Wabash Avenue.

ALBERT LORSCH.

TELEPHONE CALL, 746 CORTLANDT, N. Y.

ALFRED KROWER

## ALBERT LORSCH & Co.,

LORSCH BUILDING,

37 & 39 MAIDEN LANE, N. Y.,

167 WEYBOSSET ST.,

PROVIDENCE, R. I.

IN STOCK, A LARGE ASSORTMENT OF

# PEARLS

ALL SIZES AND  
QUALITIES.

**PROV. STOCK CO.**

HIGH GRADE ROLLED PLATE

Chains

BRACELETS, LORGNETTES.

10K. GOLD

Scarf Pins, Brooches,  
Neck Chains, Lorgnettes,  
Bracelets.

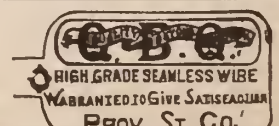

IMPORTERS AND CUTTERS OF DIAMONDS  
 65 Nassau St. NEW YORK.  
 Cor. John.

DIAMONDS and Cutters.  
 L. & W. KAHN & CO.,  
 175 Broadway, N. Y.

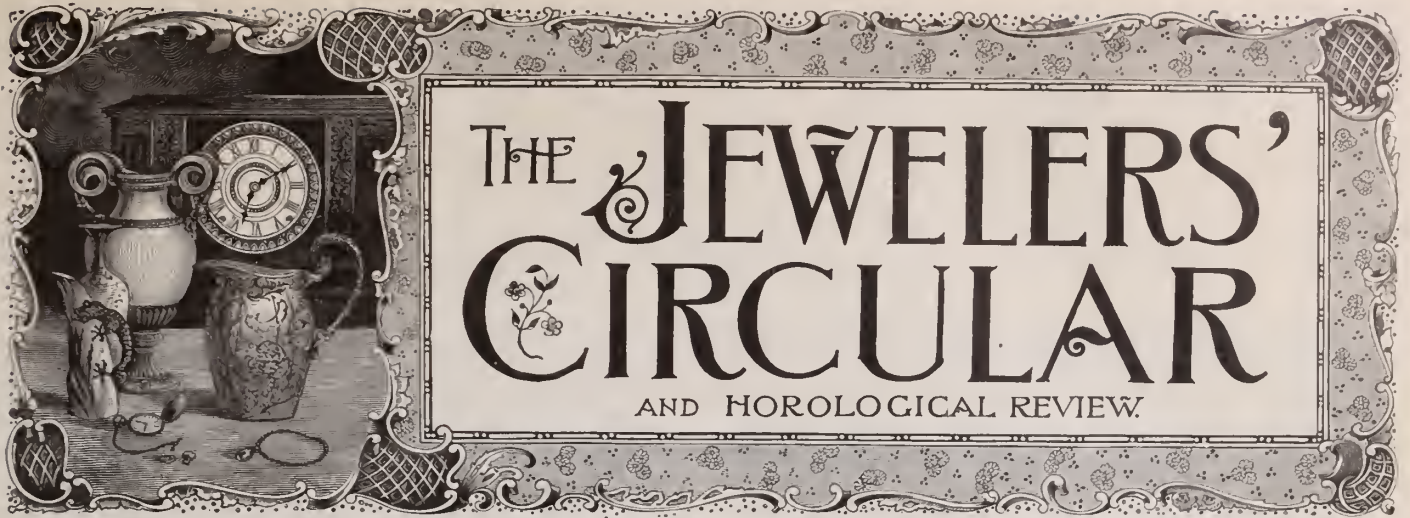

Corbin Building, 11 John St., Corner Broadway, New York.

Copyrighted by THE JEWELERS' CIRCULAR PUB. CO.

Entered at the Post Office in N. Y. as second-class matter.

VOL. XXXIX.

NEW YORK, WEDNESDAY, DECEMBER 13, 1899.

No. 20.

## A JEWELER AND HIS GIGANTIC PROPOSAL.

FROM the brain of a well known jeweler, Henry A. Spaulding, has been evolved a scheme for the good of the nation, of such gigantic proportions that no adequate description of it can be presented in the confines of a newspaper article. This scheme comprehends the erection of a

It is to be a museum of living history, and that title has been adopted for it provisionally. Everything about it is to be on a scale of true magnificence. The idea is not a new one. The subject has been under consideration for many years, and an exhaustive study of the great museums

to permit the greatest warship to lie at it. From this quay a mighty stair of stone, ornamented with noble statuary, is to lead grandly upward to the museum. It is hoped that the building will be used by the city and by the nation as the place of welcoming all distinguished guests who



THE MUSEUM OF LIVING HISTORY, PROPOSED AND DESIGNED BY HENRY A. SPAULDING, A ONE TIME JEWELER.

structure that will be for the United States even more than what the Kensington Museum is for England, for it is hoped that it will become the Parthenon of America. George B. Post, the noted architect, has completed plans for the structure, a front elevation of which is here presented.

of Europe has been made, that all their good points may be used to advantage in this American building, which is to rise in the upper West Side of New York city in a position that will command an approach to the North River. A part of the plan is a huge stone quay, large enough

can be brought to it by water.

The material to be used is gray granite and marble, and the ground form is that of a cross, superimposed on a circle. This circle is 800 feet in diameter, and it incloses five circular galleries; two concentric circular galleries on the main floor,

# Our New Lines For The Spring Trade

will be ready right after Christmas, and as we are sparing no effort or expense to bring them to perfection they will be lines not surpassed by any on the market during the season. The quality will be up to our usual high standard of rolled-gold plate, while the finish is the finest that can be produced.

LOCKETS, CHARMS, BRACELETS, CHAINS, PINS, EARRINGS, SILK VEST CHAINS and HAIR CHAIN MOUNTINGS; also a large variety of those dainty little BROOCHES now in vogue, and an enlarged line of BUCKLES.



Do not allow your stock of STERLING SILVER TOILET and MANICURE GOODS and NOVELTIES to get too low, as you will have a good demand for them all through the Holiday Season.

OUR CATALOGUE IS YOURS FOR THE ASKING.

**THEODORE W. FOSTER & BRO. CO.,** 100 RICHMOND ST., PROVIDENCE, R. I.  
Successors to FOSTER & BAILEY.

## A USEFUL NOVELTY

### Bottle Openers,

in Sterling Silver and Silver Plate. The convenience and cleanliness of this form of bottling having brought it into general use, these Openers will be appreciated for the table. Send for catalogue.

MADE BY

**Goodnow & Jenks,**

SILVERSMITHS,

Stanhope and Morgan Sts.,  
Boston,

who have obtained the SOLE RIGHT from patentees to manufacture this article.



# Seasonable Goods, Real Values.



No. 1.

**SOLID OAK, PLAIN TOP, WATCHMAKERS' WORK BENCHES**, without castors, made of well-seasoned Oak lumber and put together by people who know how.

**1st QUALITY, \$9.00 NET.**

**2d " 8.00 " SOLID OAK.**

Size: Length, 40 in.  
Height, 40 "  
Width, 20 "

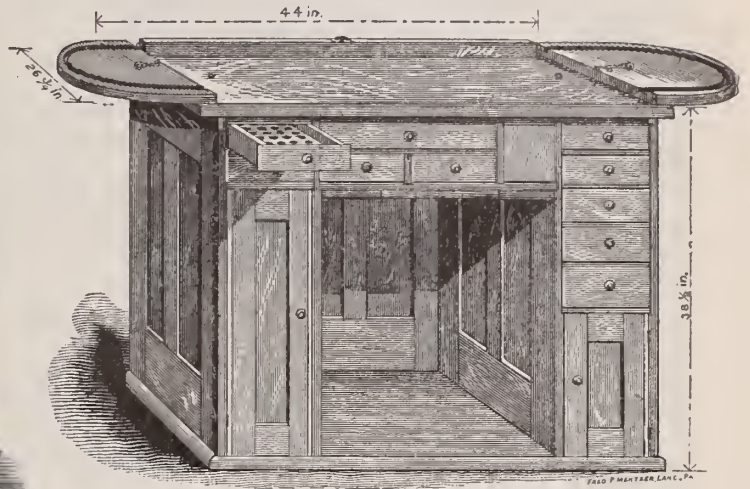

No. 2.

**OUR ROLL-TOP SOLID OAK BENCHES** are made of the same material as the plain tops, have curtain tops, 10 drawers, apron, chalk hole, lock automatically and are on castors

**PRICE, \$14.00, NET CASH.**

Size: Length, 44 in.  
Height, 40 "  
Width, 26 3/4 in.

## Double-End and Single-End Gravers and Liners.

Our GRAVERS have been imitated, in part, as to style only. The quality of our gravers stands the use better than any other graver made to-day.

If your jobber does not have them, insist on getting them, and take no other, or send to us, where your wants will be filled with dispatch.

# L. C. REISNER & CO.

Manufacturing Jobbers, Importers and Exporters,  
Watch Materials, Tools and Supplies,

Jewelry Repairers for the Trade.

LANCASTER, PA.

# "OMEGA" WATCHES.

NONE BETTER MADE. OVER 1,000,000 IN USE.

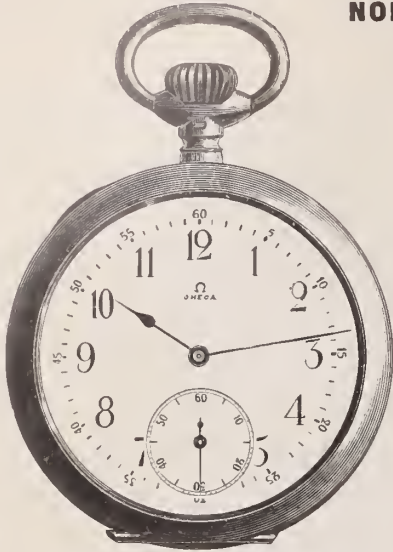

Pendant Set. 12, 14 and 16 Size.  
Made in Gun Metal, Silver, Gold-Filled  
and Solid Gold Cases.

Send for Price-List.

Our 10 Ligne O. F. "Omegas," full Jeweled Anchor Movements, in 14 K., plain polished or enameled cases, are "just the thing" for the Holiday trade.

Our 12 Size "Omegas," made in 7 and 15 Jewel grades, and Our 16 Size "Omegas," made in 6 different grades—7 Jewels to 21 Jewels—are particularly desirable where fine timepieces are desired.

The "Omegas" are sold only to the regular trade, so no prices will be found in any publication whatever, thereby insuring a good profit.

**Edmond E. Robert, 3 Maiden Lane, N. Y.;**

**Cross & Beguelin, 17 Maiden Lane, N. Y.,**

**SOLE SELLING AGENTS.**

## Of Greatest Importance

to the live manufacturing Jeweler is a careful consideration of our lines of Jewelers' Findings.

NEW ASSORTMENTS OF

**Buckles, Galleries, Brooches,  
Settings, Pins, Etc.**

**THOS. W. LIND,**

MANUFACTURER OF JEWELERS' FINDINGS,

67 FRIENDSHIP STREET,

PROVIDENCE, R. I.





.. TO ..

**THE RETAIL TRADE:**

Do you know how much you **SAVE** by  
buying your Filled Chains **DIRECT**?

Our Chains, in point of

**QUALITY**  **and Finish,**

are **SUPERIOR** to any on the market.

SEND FOR SELECTION.

**THE BASSETT JEWELRY CO.,**

Successors to

**The Kent & Stanley Co., Ltd.,**

**PROVIDENCE,**

**R. I.**

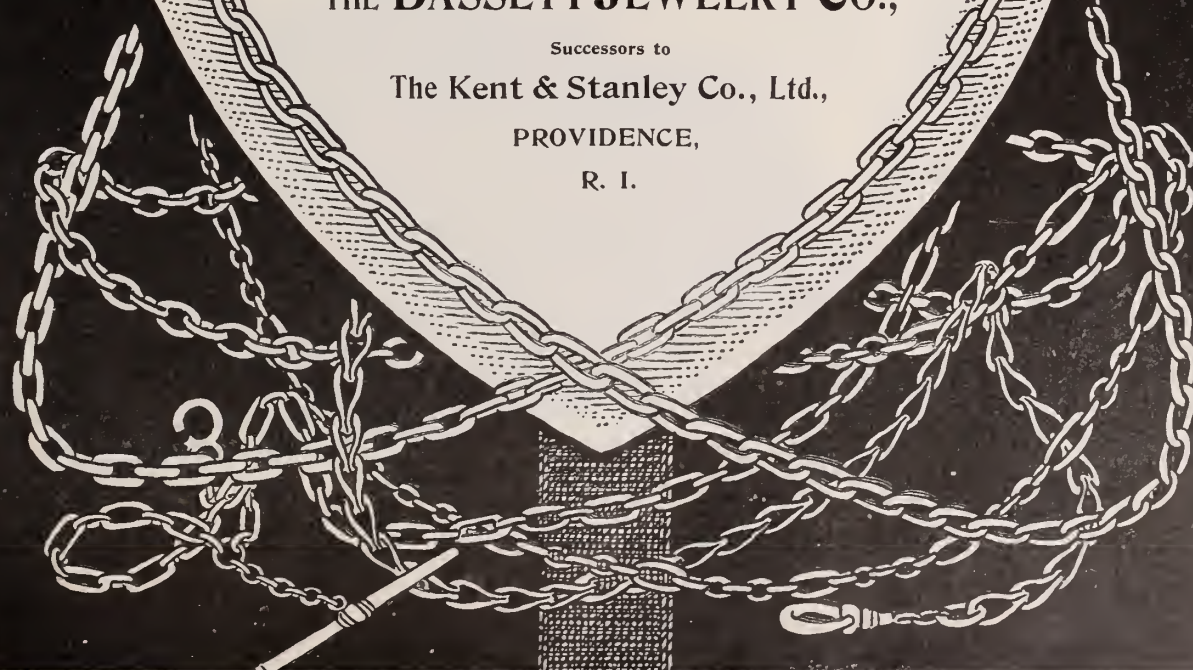



NO. 257.



NO. 258.



No. 1000.

**ALMOND DISHES**  
**SOMETHING FOR YOUR**  
**HOLIDAY TRADE**

THESE DISHES ARE OF GOOD  
 WEIGHT AND THE PRICES  
 AT WHICH WE ARE SELLING  
 THEM PERMIT OF THEIR  
 BEING USED AS LEADERS  
**BON · BON · DISH**  
**TO MATCH · · · WRITE**

FOR PRICES  
 ILLUSTRATIONS  
 FULL SIZE



**R. WALLACE**  
**& SONS MFG. CO.**  
**SILVERSMITHS**  
**WALLINGFORD · CT.**  
**BRANCHES**  
**226 · 5<sup>TH</sup> · AVE · NEW · YORK**  
**109 · WABASH · AVE · CHICAGO**  
**120 · SUTTER · ST · SAN · FRANCISCO**

having together a width of 125 feet; two below these, and one above the outer gallery. The outer circular gallery thus has two stories above the ground; the inner circular gallery has one. These circular galleries are intersected, diametrically, on the ground floor, by four wings at right angles to each other and having each a length of 800 feet, a width of 200 feet and a height of 35 feet. These four wings are to be known respectively as the Donors' Hall, the Hall of Literature, the Hall of Religion and the Hall of Gifts. They will be surmounted, at their intersection, by a central and open dome, rising to a height of 404 feet, and having at its base a diameter of 250 feet. The interior of the building is carefully and elaborately planned to systematically and comprehensively represent every branch of art, science and industry—every form of human endeavor.

The provisional builder's estimates of the proportions of this building are for a structure to cover about nine and one-half acres of ground. The length and width of the building, 520 feet; floor surface of rotunda, 24,328 square feet; four entrance halls, each 11,448 square feet; four inner galleries, each 3,230 square feet; four outer galleries, each 5,616 square feet; one first floor, including stair halls, etc., 130,880 square feet; second story, 51,464 square feet; in all, 182,344 square feet. Picture lines, rotunda, 496 feet; inner galleries, 944 feet; outer galleries, 1,164 feet; upper galleries, 4,056 feet; in all, 6,660 feet. The cubic contents of the building are to be 17,736,355 cubic feet, of which 4,605,488 cubic feet are below the first floor.

The originator of the idea is, H. A. Spaulding, formerly of Tiffany & Co. He has been working on this, which he hopes to make his lifework, for many years, and since his retirement from active business he has made rapid progress with it. He has seen and interested the President and his Cabinet and scores of prominent and rich men, especially in New York. The idea first came to him while he was in Paris, over 20 years ago. In 1881 and 1882 he made a tour of all the courts of Europe, during which he met every one of

the rulers and most of the men and women then prominent in the history of the world. Mr. Spaulding's wide experience in the field of art has made him unusually enthusiastic about his plans and eminently fit to make them properly. In addition to this, he had invaluable experience at the last Paris Exhibition, where he represented Ill-



HENRY A. SPAULDING,  
CONCEIVER OF THE MUSEUM OF LIVING HISTORY.

inois as State Commissioner. After the exhibition there he went to Japan, and thence to other parts of the Orient. In Japan he was elected a member of the Fine Arts Society. He is a member of the Metropolitan Museum of Art here, the Historical Society of Chicago and the American Fine Arts Society.

In explaining his plans he said: "As man progresses and learns the steps by which he has climbed out of the past, surveying the rude ladders upon which he has mounted, a natural desire arises to mark

off the heights he has gained by white monuments, carved with nicest cunning and reared not alone for his own satisfaction, but to point other more tardy climbers. This is his 'record mark'—a line back of which civilization and all that makes for progress shall not retrograde, an epoch from which to date anew the story of man's struggles and triumphs. Thus is born the exposition, the centennial, the world's fair of the nations. By these aggregations of art and industry the people of the whole earth come in touch with each other. They are intellectual exchanges for the nations, international clearing houses for the paper of a world's trade, living encyclopedias of the planet's formation, universal compendiums of the race's knowledge, shining gems crystallized from the precipitation of the chemistry of progress. Such was the first World's Exposition, the Crystal Palace of London; such was the International Exposition at Paris; such was the magnificent World's Columbian Exposition, and such must be all those to which the future is to give birth.

"Such a monument of progress is the South Kensington Museum, an outgrowth of the Crystal Palace. In this great school, founded by the late Prince Albert, one of the most enlightened minds of his time, with its means and adjuncts for education, we see a speaking illustration of what can be done by vital force. It is safe to say that its influence upon the minds of the British people is greater than all the inactive art collections of Great Britain put together. It is real eloquence; the rest are sermons delivered with folded arms and closed eyes. The Kensington Museum from its first foundation became at once a potent influence in the cause of art among the people of the British Isles. It has proven of inestimable value to them, and its influence is now felt in the remote corners of Her Majesty's dominions and of the world.

"America should have its Parthenon—a worthy abiding monument to its ever-accumulating evidences of the great part it is destined to play in the story of the nations."

# THE APOLLO

WARRANTS THE EPITHET "POPULAR,"

as shown by sales from Maine to Oregon.

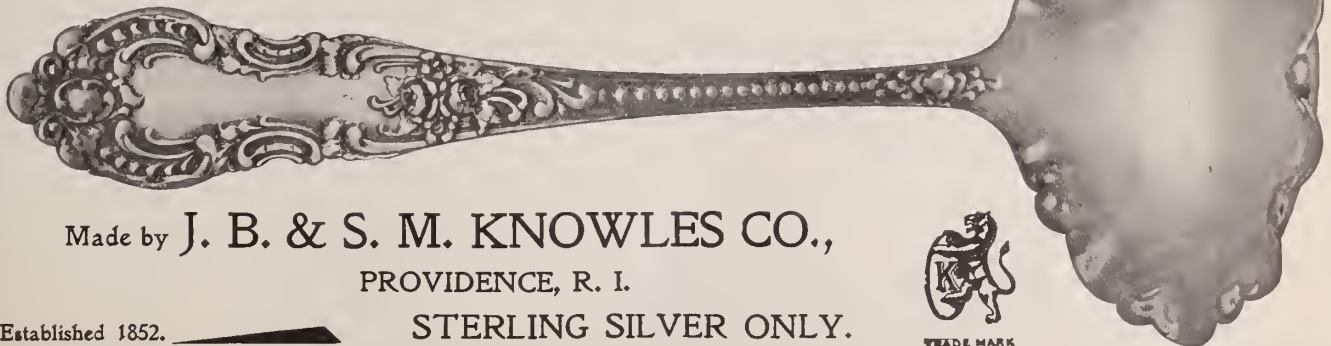

Made by J. B. & S. M. KNOWLES CO.,  
PROVIDENCE, R. I.

Established 1852.

STERLING SILVER ONLY.



TRADE MARK

**DIAMONDS.**  
**Wm. S. Hedges & Co.,**  
 IMPORTERS OF  
**Diamonds and Precious Stones.**  
**DIAMOND JEWELRY.**  
**170 Broadway, New York.**  
 26 Holborn Viaduct, London.

## SCHULZ & RUDOLPH,

....Importers and Cutters of....

**..DIAMONDS..** .....AND OTHER....  
**PRECIOUS STONES.**

SOLE AGENTS FOR THE CELEBRATED

**JULES JÜRGENSEN WATCHES AND**  
**COPENHAGEN, CHRONOMETERS.**

28 John and 65 Nassau St., New York.

**MOUNT & WOODHULL,** FORMERLY WITH LATE FIRM OF  
 RANDEL, BAREMORE & BILLINGS,  
 .... IMPORTERS OF ....

**Diamonds, Other Precious Stones, Pearls, Etc.,**  
**Makers of fine DIAMOND JEWELRY,**

26 MAIDEN LANE (SOUTHWEST CORNER), NEW YORK.  
 NASSAU STREET

JOHN C. MOUNT.

ADDISON W. WOODHULL.

RUBIES.

SAPPHIRES.

**C. G. MALLIET & CO.,**

EMERALDS.

14 MAIDEN LANE, N. Y.

DIAMONDS.

## The Bowden Rings

ARE COMPLETE IN VARIETY, CORRECT  
 IN QUALITY AND PERFECT IN FINISH.  
 WE MAKE EVERY VARIETY OF FINGER  
 RINGS

**J. B. BOWDEN & Co.,**

1 MAIDEN LANE,

NEW YORK.

## FALL and HOLIDAY FASHIONS.

A LADY'S RAMBLES AMONG THE JEWELERS.

Crystal seems very fashionable in umbrella handles; and in it are carved the heads of greyhounds, swans and other creatures that lend themselves well to the purpose. Few things are prettier than a crystal ball cut in many facets, and smooth straight tips of the same material are also seen. Staghorn is much used, sometimes curiously carved and tinted, and pearl has taken on new life in connection with silver gilt. Serpents twisted somewhat into the shape of a shepherd's crook are attractive in small, light silver handles. The head of a dragon in oxidized silver forms a massive handle for a man's umbrella. Crooks, straight handles, knobs and balls—no one of them has precedence of the other, while old designs of beasts and birds are equally in vogue. Golf club designs also contribute to the attractive medley.

Emblems of athletic sports, hunting, fishing, driving, racing, etc., remain always in season and in favor.

A slender band and invisible mounting are used for the finest solitaire rings.

The list of silver toys for cabinets and silver tables has received an addition in the shape of miniature tea sets.

Triple hoop rings for men appear to please.

Quite new are tiny charms carved from coral. These include little images, a skull and cross bones, rabbit, pig, clover leaf, etc.

A handsome line of short handled double lorgnons employs the richest shades of yellow and red gold, with elaborate decoration including some intricate carving. Brilliants are often introduced; olivines represent a favorite colored stone for this purpose, and green enameling proves effective.

ELSIE BEE.

### Proceedings of the Jewelers' League.

The regular monthly meeting of the executive committee of the Jewelers' League was held Dec. 8. There were present: President Hayes, Vice-Presidents Fessenden and Bowden, Messrs. Karsch, Street, Lissauer, Breckinridge and L. Stevens, Jr., secretary. Upon motion, duly seconded, Mr. Fessenden was elected chairman *pro tem*.

The report of the treasurer was presented and approved. One request for change of beneficiary was received and upon motion granted, and the following applicants were admitted to membership: F. T. Short, Chicago, Ill., recommended by I. W. Nichols and J. F. Tenney; C. P. Jennings, New York, recommended by J. Strauss and F. E. Knight.

The League paid on Dec. 8, 1899, \$5,000 to the beneficiary of Wm. Smith, Jr., Providence, R. I. Mr. Smith has been a member since Oct. 1, 1880, and had paid into the League for dues and assessments \$926, an average of about \$49 per year.

The next meeting will be held on Jan. 5, 1900.

**Precious Stones: London Market**

HATTON GARDEN, London, Eng.,  
December 2, 1899.

No further advance is yet announced in rough diamonds. Reports as to business are curiously divergent. Some mounters report that during the last month they have been exceptionally busy, while others are obliged to turn off men.

Mr. Rhodes once stated that the best test of the diamond market was the price of DeBeers shares. They have been very dodgy this week—on Thursday rising in London and falling in Paris. To-day, on the strength of Lord Methuen's advance towards Kimberley, they have advanced  $\frac{1}{2}$  to 29 $\frac{1}{4}$ . The relief of Kimberley is now practically assured and will put an end to much of the speculation as to the condition of the mines. The large area of the mining properties—nearly 12 acres—makes it extremely probable that considerable damage has been done which it will take time to repair.

Prospects generally are not bright. The Court is again in mourning and many leading families are in the same position through the loss of relatives at the war. Diamonds and pearls will, therefore, be still in vogue.

In the ordinary course, a further rise of 5 per cent in rough is due on Monday, Dec. 4, but the double rise in October may have upset this arrangement. R. F.

**The Pearl Market.**

The pearl market, it appears from information gathered abroad at this time, is now not only as strong as ever before, but there is no indication of reduction in price in the future. In reference to the situation, one of the largest dealers in Paris stated in a letter to this country, last week, that he had just had an interview with one of the most prominent merchants in Bombay who said there was absolutely no prospect of cheaper pearls in the future. On the contrary, this Bombay merchant informed him that undrilled pearls would, in all probability, be dearer within a short time. The entire pearl business, he said, is now in the hands of four enormously rich Indian houses, and these concerns would rather lock up their stock in their safes and stop selling than come down in the price. According to the positive assurances of the Bombay merchant, the four houses control the bulk of the pearl output, and have agreed to take the new crop at about 30 per cent advance over last year's prices. They, therefore, could not under any circumstances think of a reduction in price, but would probably demand an increase to make up for this advance. That the sale or non-sale of the present product could make a difference in the price at which pearls would be sold to the importers was absolutely denied. THE CIRCULAR has been informed by representatives of prominent pearl houses of this country that the information as given in the letter above quoted is verified and borne out by their own correspondents.

Sam Sterchi, Terre Haute, Ind., is able to be out again after an attack of typhoid.

ESTABLISHED 1840.

**Chester Billings & Son,**

Successors to **RANDEL, BAREMORE & BILLINGS,**  
IMPORTERS OF

1840 RANDEL & BAREMORE.  
1856 RANDEL, BAREMORE & CO.  
1880 RANDEL, BAREMORE & BILLINGS.

**DIAMONDS**

OTHER PRECIOUS STONES AND PEARLS.

58 Nassau Street,  
29 Maiden Lane, 22 Holborn Viaduct,  
NEW YORK. LONDON, E. C.

❖ **DIAMOND JEWELRY.** ❖

*Oppenheimer Bros. & Veith,*

*Importers and Cutters of*

*Dealers in*

**Diamonds**



**Watches,**

*Cor. Nassau and John Streets,*  
*(PRESLOTT BUILDING.)*

*...New York...*

*Amsterdam,*  
*2 Tulp Straat.*

*London,*  
*45 Holborn Viaduct.*

**Pearls**

**Opals**

Importers and Cutters

**GOODFRIEND BROS.,**

Precious and Imitation Stones

9-13 Maiden Lane, N. Y.

174 Weybosset St., Providence, R. I.

10 Rue Cadet, Paris.

TELEPHONE, 662 CORTLANDT.

**John F. Saunders,** Cutter and Importer of

**DIAMONDS**

AND OTHER  
PRECIOUS STONES.

FINE PEARLS A SPECIALTY.

68 Nassau St., cor. John St., Sheldon Building, Room 16, NEW YORK.

**ALOIS KOHN & CO.,**

SOLID GOLD CHAINS,

4 MAIDEN LANE,

Near Broadway, N. Y.

We call the attention of the Trade throughout the country to our line of

**LORNETTE AND GUARD CHAINS.**

Will send Samples on Memorandum on receipt of satisfactory reference. Correspondence Solicited.

## PEARLS—DIAMONDS

### Special Advantages

arise from doing business with "specialists."

We are distinctly "specialists," dealing in but one line of goods.

We are dealers in Pearls and Precious Stones exclusively.

In consequence, most advantageous buying results and the best selections are put before our customers.

### Alfred H. Smith & Co.,

182 Broadway, N. Y. LONDON.  
CHICAGO.

And Other Precious Stones.

### The Convening of Congress.

#### Introduction of Bills of More or Less Intimate Interest to the Jewelry Trade.

WASHINGTON, D. C., Dec. 5.—Congress has convened and with it has come the usual introduction of an avalanche of bills, covering all subjects, from the monetary question to that of the employment of criminal labor; all of which may be taken as an earnest of the very great amount of business that will be brought up for action during the present session. The two great political parties are more evenly divided than they have been for many years past, and there is much new material to be developed on both sides. While many of our ablest men have passed over the Great Divide and many more have been retired since the last session of Congress, yet it is reasonable to suppose that among the new men will be found some new stars of as great if not greater magnitude, and spirited discussions may be expected on matters of general importance.

Among the measures already introduced is one by Representative Thomas, of North Carolina, asking that the Secretary of the Treasury be authorized to cause to be placed a clock with an illuminated dial, or such other dial as the supervising architect might see fit to suggest, upon the public Government building in Newbern, for which the sum of \$5,000 is asked to be appropriated.

Representative Terry has introduced a bill for the amendment of the Act to Regulate Commerce so as to permit common carriers to allow reduced rates of transportation to various named classes of persons, among them commercial travelers, and an increased weight of baggage when such traveling and business shall be in connection with legitimate business; no unjust discriminations to be allowed, and the concessions to be similar in all cases.

A bill has been introduced to protect and maintain the integrity of the United States coin, which provides that no coins shall be refused in exchange at or in payment to the Treasury on account of being clipped, mutilated, punched or burnt, so long as they can be recognized as genuine United States coin. Two provisions are added, one to the effect that a deduction may be made to the amount of the coinage metal that has been eliminated by means of such mutilation, the other, that the Secretary may require the coin to be presented for redemption in sums of \$20 or multiples thereof.

Representative Gibson has introduced a bill providing that all goods and wares made or manufactured in whole or in part by convicts shall be branded, labeled or stamped, permanently, "Made by convicts at —," giving name of place, Territory or State where same was made; that all goods so made or manufactured when transported into some other State or Territory shall be subject to the laws governing in such circumstances, whether imported in original packages or not; all goods transported in violation of such laws and not first seized under the laws of such State or Territory are to be considered forfeited to the United States, and every person who intentionally aids such viola-

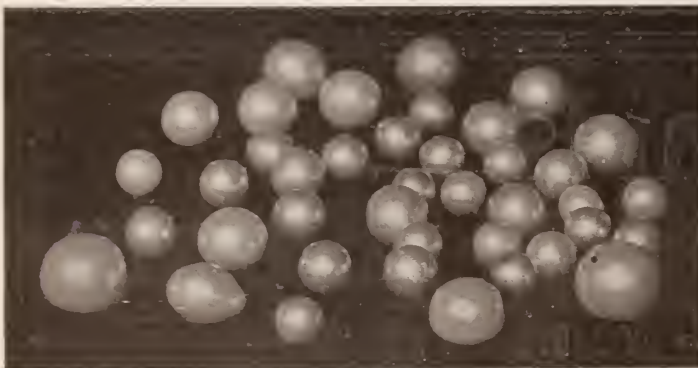

"The  
Pearl  
House."

We have no salesmen;  
call or write.

**EISENMANN BROS.,**

PARIS, 3 Rue St. Georges.

21 & 23 MAIDEN LANE, NEW YORK.

## Rubies and Emeralds.

BYRON L. STRASBURGER & CO.,

Watches and Diamonds,

17 MAIDEN LANE,

NEW YORK.

tions shall be deemed guilty of a misdemeanor, punishable by a fine of not more than \$1,000.

#### Death of Edouard Beguelin.

The announcement of the death of Edouard Beguelin, watch manufacturer, of Berne, Switzerland, which occurred on Nov. 21, was received in New York, last week. Mr. Beguelin was a brother of Tell A. Beguelin, importer of watches and materials, John and Nassau Sts., New York, and of the late Henry E. Beguelin, of Cross & Beguelin, 17 Maiden Lane, New York. His death was unexpected and came as the result of an operation. The deceased was born in Berne, Switzerland, 58 years ago, and was the son of Henry Beguelin, the well known watchmaker of that city. As a boy he learned the watchmaking trade with his father and later entered the business. Here he continued, and at his father's death, about 15 years ago, succeeded to the business. A widow and four sons survive him. One of the sons, Henry Beguelin, was associated with the deceased in his business and will probably continue it.

#### The Brass Combine Seems Now an Assured Fact.

ANSONIA, Conn., Dec. 8.—The brass combine may now be said to be an assured fact. Recently three of the Valley concerns have taken advantage of the provisions of an act of the General Assembly of Connecticut, of 1874, and merged themselves into what is to be known as the American Brass Co. The three concerns referred to are: The Coe Brass Co., of Torrington and Ansonia; the Ansonia Brass & Copper Co., and the Waterbury Brass Co. This is to be a nucleus of the organization, the door having been left open for others to come in, which they will probably do later on. Officers have not yet been elected, but they probably will be somewhere about the first of January. Possibly Charles F. Brooker will be president of the new organization. An organization under the title of the American Brass Co. has been maintained since 1874 simply to preserve the charter then granted, but no successful attempt has been made heretofore to vitalize the corporation.

#### Serious Offence Charged Against a Medical Student.

BIRMINGHAM, Ala., Dec. 7.—Frank Johnson, of Jernigan, Ala., a student of the medical college here, is in the county jail, the charge being that he purloined a diamond worth \$140 from the store of H. C. Abbott & Bro. It is charged that a couple of weeks ago Johnson had some work done at the Abbott store, and while there one of the clerks showed him some diamonds. One handsome stone was missing after Johnson had left.

Messrs. Abbott offered \$25 reward and a couple of detectives were put on the case. Johnson was arrested yesterday after having traded the stone to A. S. Smith for \$50 and a gold watch. Johnson states that while walking on the street near the Abbott store he found the stone on the sidewalk. He picked it up and later on



## Selections of \_\_\_\_\_ Diamond Jewelry.

Write to us for  
Diamond Jewelry on  
memorandum.

We fill all orders  
the same day as received  
and you never miss a

sale when you show our goods.

Try us once and you will do so again.

*Kohn & Co*  
9.11.13 MAIDEN LANE.  
NEW YORK.

## Gifts for Men



In 14-Karat Gold—ORNAMENTED WITH PRECIOUS  
STONES—and in Sterling Silver. Goods that appeal  
to refined people at all times. Made handsomely,  
heavy and exclusively for the Jewelry trade.

**Woods & Chatellier,**

Gold and Silversmiths.

860 Broadway, N. Y.  
42-46 Hill St., Newark, N. J.

## MATHEWS & PRIOR,

DESIGNERS AND MAKERS OF

## Sterling Silverware

TO THE LEGITIMATE

## JEWELRY TRADE ONLY,



245-247 West 28th Street,  
New York City.

made the trade with Mr. Smith. He says he returned the watch to Mr. Smith as soon as he heard the stone was stolen and gave an order for the money. The stone has been returned to Messrs. Abbott.

#### Death of C. C. Stevens.

KENNEBUNK, Me., Dec. 5.—C. C. Stevens, aged 79 years, died of paralysis Friday. He was a resident of Boston for 20 years, being engaged in the jewelry business.

G. F. Dutcher has purchased the jewelry store of Mundy & Graham, Dodgeville, Wis.

W. B. Thimming, of Bessemer, Mich., will locate a jewelry repair shop at Wausaukee, Wis.

#### The Methods of a Gift Enterprise Magazine.

NEWBURYPORT, Mass., Dec. 7.—In the police court last week, Associate Justice Jones presiding, the defendant in a larceny case was discharged. From the testimony it appeared that an agent had struck a bargain with the defendant, something to this effect: She was to take 95 numbers of a magazine and was to receive as a premium a watch. The certificate, or contract, stated that after 65 payments, at 10 cents each, had been made, she was to have the privilege of selecting a watch. It seems that the defendant had made 49 payments, and being desirous to obtain the watch to give a son, who was soon to have a birthday, she tendered the agent a sufficient sum of money to equal that which would

have been paid in 65 payments. The agent thereupon told her she would have the privilege of selecting the watch, but that it would not be delivered until the entire 95 payments had been made. The purchaser said that she had understood by the word selected that the watch was to be forthcoming as soon as 65 payments had been made, and having been allowed to take the watch she proposed to hold it. The agent thereupon brought her into court on a charge of larceny. The Judge held that she was not guilty.

#### Summons Out for the Arrest of J. H. Miles.

SALT LAKE CITY, Utah, Dec. 8.—J. H. Miles, the erstwhile jeweler, who failed some time ago, is wanted by the officers to answer to a charge of embezzlement. The complaint was sworn to by H. G. Button and a warrant for the arrest of Miles was issued. Button alleges that he left a valuable watch in the care of Miles and that the latter failed to return it. A more serious charge is also likely to be made against Miles, it is said. The officers say the accusation regarding the watch, however, is sufficient grounds for holding him, if he can be found, until the other charge, that of embezzling about \$500, funds of one of the local lodges of the order of Woodmen of the World of which Miles was treasurer, is formulated. It is stated Miles has gone to Montana.

#### Trade Journal Publishers Agitating for Increased Postal Facilities.

At the annual meeting of the American Trade Press Association, of which THE JEWELERS' CIRCULAR is a member, a committee of five were appointed to confer and cooperate with Postmaster Van Cott, of New York, in his project to secure for the city adequate relief from the great congestion in the postal service, in the shape of a new post office building to be erected in some location convenient to the Grand Central Depot. The committee have adopted the following resolutions:

WHEREAS, The postal facilities of the City of New York have long been insufficient for the requirements of the business, resulting in loss and inconvenience to all classes of the business community, particularly to publishers of newspapers, who are affected both in the delay in the distribution of their publications and the receipt of their mail;

WHEREAS, The present New York Post Office is entirely inadequate to the demands of the service, being now overcrowded to a degree which is hurtful to the health of the employes and discreditable to the Government, the men being compelled to work under conditions to which we as private employes would be unwilling to subject our employes; and

WHEREAS, It seems impossible that any sufficient improvement in the postal service of New York City can be attained without the building of a new Post Office,

Resolved, That the American Trade Press Association heartily endorses the bill for the erection of a new Post Office in New York City which is about to be introduced in Congress, and urges its members to use all the influence of their journals to promote its passage.

Resolved, That a copy of this preamble and resolution be sent to the Postmaster-General, Postmaster Van Cott, the Postal Committees of the Senate and House of Representatives and to our Senators and Representatives.

NEW YORK, Dec. 7, 1899.

J. J. Wills has removed from Washington C. H., O., to Pottsville, Pa.

## Holiday Buyers.

During the coming week you will have many buyers wishing Diamond and Precious Stone Jewelry, some of whom will want to see pieces you may not have in stock; that is when our Diamond and Precious Stone Department can give you great assistance. A letter or telegram will procure for you a liberal selection package to meet any such special demands.

### HAYDEN W. WHEELER & Co.,

TWO MAIDEN LANE, N. Y.

50 HOLBORN VIADUCT, LONDON.



**Imports and Exports of October, 1899, and the Preceding 10 Months.**

WASHINGTON, D. C., Dec. 1.—The summary statement of imports and exports for the month ended Oct. 31, 1899, and the 10 months ended the same date, compared with the corresponding periods of 1898, has been issued, and contains the accompanying figures relative to the jewelry trade:

**Retail Jewelers' Seasonable Souvenirs.**

R. P. Thorn & Sons, 9 N. Pearl St., Albany, N. Y., are sending out a neat holiday card, telling about the attractive goods they offer for the holidays.

F. W. Sim & Co., Troy, N. Y., have just issued their annual jewel catalogue. The book contains 80 pages, which include photographic reproductions of articles of jewelry and novelties in gold, silver, leather and cut glass.

IMPORTS OF MERCHANDISE.

ARTICLES.	OCTOBER.		TEN MONTHS ENDING OCT. 31.	
	1898.	1899.	1898.	1899.
	Value. Dollars.	Value. Dollars.	Value. Dollars.	Value. Dollars.
<b>CLOCKS AND WATCHES, AND PARTS OF:</b>				
Clocks and parts of.....dut..	42,261	54,725	207,237	262,145
Watches, watch materials and movements.....dut..	109,245	151,126	678,168	930,840
<b>JEWELRY, MANUFACTURES OF GOLD AND SILVER, AND PRECIOUS STONES:</b>				
Diamonds, uncut, including miner's, etc., not set, free .....	268,817	720,576	1,851,362	4,416,672
Diamonds, cut, but not set.....dut..	665,478	584,805	4,918,239	7,992,278
Other precious stones, rough or uncut.....free..	2,345	9,148	24,838	48,316
Other precious stones, cut, but not set.....dut..	150,309	288,060	1,438,382	2,214,609
Jewelry, and manufactures of gold and silver.....dut..	173,292	471,060	1,688,286	4,011,823
<b>Total.....</b>	<b>1,260,241</b>	<b>2,073,649</b>	<b>9,921,107</b>	<b>18,683,698</b>
<b>PRECIOUS STONES, ETC. (free), imported from—</b>				
United Kingdom .....	62,180	712,869	820,053	3,549,992
France .....	193	.....	54,428	18,957
Netherlands .....	208,179	16,502	980,128	886,317
Other Europe .....	56	352	14,689	7,914
Brazil .....	.....	.....	20	1,808
Other countries .....	554	1	6,882	.....
<b>Total.....</b>	<b>271,162</b>	<b>729,724</b>	<b>1,876,200</b>	<b>4,464,988</b>
<b>JEWELRY, AND OTHER PRECIOUS STONES, ETC. (duti-able), imported from—</b>				
United Kingdom .....	227,110	369,100	2,278,661	4,362,841
France .....	496,509	586,212	2,705,464	4,460,845
Germany .....	68,272	110,616	576,793	829,653
Netherlands .....	80,443	205,716	1,815,671	3,656,474
Other Europe .....	90,007	68,766	612,820	877,674
British North America .....	150	183	2,088	6,604
Mexico .....	254	1,462	4,497	17,046
East Indies .....	.....	274	9,794	984
Other countries .....	25,334	1,596	39,119	6,589
<b>Total.....</b>	<b>989,079</b>	<b>1,343,925</b>	<b>8,044,907</b>	<b>14,218,710</b>

EXPORTS OF DOMESTIC MERCHANDISE.

<b>CLOCKS AND WATCHES:</b>				
Clocks and parts of.....	103,080	103,900	795,739	924,728
Watches and part of.....	78,697	47,897	709,730	536,257
<b>Total.....</b>	<b>181,777</b>	<b>151,797</b>	<b>1,505,469</b>	<b>1,460,985</b>
Jewelry .....	52,025	69,016	469,696	617,876
Other manufactures of gold and silver.....	20,182	20,319	174,513	187,749
<b>Total.....</b>	<b>72,207</b>	<b>89,335</b>	<b>644,209</b>	<b>805,625</b>
Plated ware .....	45,026	51,268	325,345	394,372

OTTO K. TREIBS. PAUL E. TREIBS.

**TREIBS BROS.,**

68 Nassau St., New York.  
139 Mathewson St., Providence, R. I.

CUTTERS AND IMPORTERS OF

**Opals.**

F. E. TREIBS,

Oberstein, Germany.  
ESTABLISHED 1842.

HERMANN TREIBS. ALBERT TREIBS.  
EMIL TREIBS.

**Survival of the Fittest.**

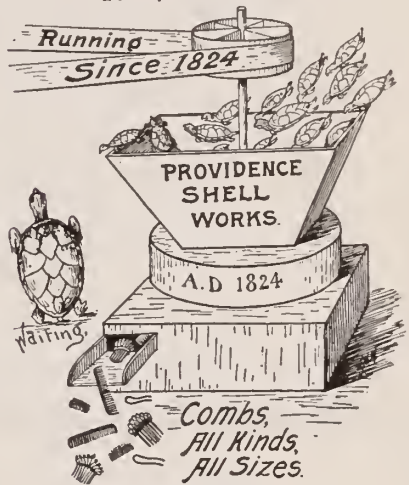

POTTERS COMB FACTORY.  
PROVIDENCE, R. I.

**We Grind for You,  
Send along your Work.**

**CASH OFFERS.**

If at any time you have offered to you by your customers any Jewelry containing diamonds, pearls or other precious stones, and you do not care to buy them yourself, send them to us and we will submit an IMMEDIATE CASH OFFER. Trade and Bank References if desired. Established 1880. Correspondence solicited.

CHARLES S. CROSSMAN & CO.,  
3 Maiden Lane, New York.

SCIENTIFIC RUBIES  
OPALS  
OLIVINES

CATSEYES | SAPPHIRES | DIAMONDS | RUBIES | EMERALDS | PEARLS | PEARL NECKS | PEARL ROPES

Pearl Collarettes, mounted with Diamond Bars.

**PEARLS, DRILLED AND UNDRILLED.  
PEARL ROPES, NECKS and COLLARETTES.**

**We are buyers of American Pearls.**

LONDON: 19-20 Holborn Viaduct. **JOSEPH FRANKEL'S SONS,** 68 Nassau Street, NEW YORK.

TELEPHONE, 3899 CORTLANDT.

FANCY COLORED DIAMONDS and GEMS in PEARLS and PRECIOUS STONES.

## Selling Silver Plated Ware.

### Traveling Salesman's Suit Against C. Rogers & Bros. Creates a Lively Time in Court.

MERIDEN, Conn., Dec. 8.—One of the most interesting civil cases tried in Meriden for some time was that of Walter R. Bristol vs. C. Rogers & Bros., that came up before Judge Platt in yesterday's session of the City Court. Several details as regards salary, commissions, work expected of a traveling salesman, etc., were made public. Attorney G. H. Fay appeared for the plaintiff and attorney W. F. Davis for the defendants.

The plaintiff was the first witness examined and he was kept on the stand for over two hours. He said he had been in the employ of C. Rogers & Bros. for 16 years. At the time he left, the latter part of January of this year, he was receiving a salary of \$3,200 per year and traveling expenses. During the month of December, '98, he had a conversation with Cephas Rogers, asking if his services were desired another year, his five years' contract having expired. The plaintiff claims that Mr. Rogers's answer was: "Why certainly, Walter, you are the best man we've got. We can't get along without you." At another time Cephas Rogers informed the plaintiff that if the company did not go into the trust (International Silver Co.), they would want him. As the trust was not entered, Mr. Bristol considered his position secure. Concerning the custom of traveling salesmen during the holiday season, Mr. Bristol testified that they spent their time at the factory, more or less, attending to correspondence, waiting on customers, cleaning up their samples and getting ready to go out on the road again. These things occupied Mr. Bristol's attention during January, the month in dispute.

The plaintiff said that it was his custom to go to New York or Boston in the interest of the company whenever he wished, before starting on his regular western trip. During January he was at

the factory nearly every day. During that time several mail orders were received by him and turned over to the company. They amounted to over \$1,200. The envelopes were all addressed to "W. R. Bristol, Meriden, Conn." On Dec. 19 a representative of a western house called at the local factory and sent a message to Mr. Bristol, who was at home at the time. Mr. Bristol responded and sold a bill of goods amounting to \$1,918. Cephas and Gilbert Rogers were in New York at the time. On Jan. 21, a conversation relative to the sale was held between the head of the company and Mr. Bristol. Mr. Rogers said the order was a good one, and he was glad to receive it. The plaintiff thought his services for the month were worth proportionately what they were for the year, or \$271.77. He had received no pay for the month in question.

Upon cross-examination Mr. Bristol stated that usually during the month of January he spent the greater part of his time between Boston and St. Louis, but this year he remained in Meriden. On Jan. 30 he asked the International Silver Co. for employment, and he is now engaged by that concern at a salary of \$2,500 per year and traveling expenses. On Jan. 20 he asked Cephas Rogers if he should go to Boston, and the alleged reply was to wait a few days, until the combine was heard from, that prices might be arranged. Attorney Fay then asked his client what, according to his judgment, it had cost C. Rogers & Bros. to market their goods during the past four years. Mr. Bristol replied that the cost had been from 12 to 14 per cent.

John M. Harmon was the next witness, and he was asked what it would cost to market goods such as the defendant handled, judging from his experience with former concerns. Mr. Harmon thought about 15 per cent, but when asked to make a distinction between flat ware and hollow ware, and give a price, he refused to answer the question.

"You'll answer or go to jail," ruled Judge Platt. "I won't go to jail," replied the witness. "You won't?" inquired the Court, turning in his chair to look at him.

Mr. Harmon then stated the cost would be from 10 to 15 per cent on flat ware. On cross-examination, Mr. Harmon was unable to state what any company outside of the International

paid for selling its goods, and the examination was dropped.

Charles F. Monroe took the stand, but was unable to testify on the cost of putting out flat ware, although his factory's goods were sold among about the same trade. He was excused.

C. Berry Peets, manager of Rogers, Smith & Co., said he hired salesmen but never discharged them. "No, he's too good natured to dismiss them," said Attorney Davis, and the Court agreed with him. The Court took a recess at 12:45 until 2 o'clock.

At that hour, George Rockwell, of the International Silver Co., was put on the stand for the purpose of telling what it cost to market flat ware. He thought it cost from 8 to 25 per cent, the average being 12 per cent during the past five years. It might cost some salesmen 8 and others 12 per cent. He stated he had never figured the cost of selling flat ware independent of hollow ware, but, in answer to a question, said he had audited the accounts of one man on flat ware sales. When asked by Attorney Davis who that man was Mr. Rockwell declined to answer. The following dialogue then took place:

Mr. Rockwell—"I decline to answer, for I do not consider the question a fair one."

Mr. Davis—"I insist on an answer, or that all of Mr. Rockwell's testimony be stricken out."

Judge Platt—"Mr. Davis's question is permissible, and if it comes to me to decide this, Mr. Rockwell will have to go to New Haven jail until such time as he chooses to answer. I do not care to take any such step, however, and would prefer the question be answered now. If you still persist in refusing you must accompany the sheriff."

Mr. Davis—"Although it is unusual, I will allow the witness to leave the stand and consult with his attorney, if he desires."

Mr. Rockwell—"What time will I be obliged to go with the sheriff?"

Judge Platt—"I think you will go at such a time as you leave the witness box. If, however, you wish to arrange any business matters we can keep you in custody until such a time as you see fit to answer it."

Mr. Rockwell—"Well, I decline to answer the question."

Mr. Davis—"Such an instance as this has never before arisen in my experience before the bar. If you insist on going on the stand and testifying against the interests of my clients, I must insist on demanding an answer to the question I have asked. As a friend of Mr. Rockwell's I would advise him to consult his attorney."

Judge Platt—"If he wishes to retire and consult any parties before giving his final answer, I am willing for him to do so. He may go and return with his final answer."

Mr. Rockwell—"You must see as a matter of common sense, outside of law, that as confidential agent of a concern I cannot give away private matters. I am called in here and casually asked to give my opinion on the cost of marketing flat ware. I don't feel that it is fair or just to insist on an answer to the question."

After considerable more discussion Mr. Rockwell withdrew and talked the matter over with Attorney Fay, with the result that the witness's testimony was wholly withdrawn and himself excused.

Cephas B. Rogers told the Court that Mr. Bristol had called at the company's New York office during 1898, and had asked that the contract be renewed. Mr. Rogers, who was there at the time, refused absolutely to renew it. The matter was brought up three or four times at various dates, but Mr. Rogers had refused to consider the matter at Mr. Bristol's figures. The contract expired Dec. 31, and at that time Mr. Bristol was supposed to be suspended. Jan. 27 the plaintiff called at Mr. Rogers's home and talked with him regarding the renewal of the contract. From \$3,200, Mr. Bristol came down, \$100 at a time, to \$2,000. Plaintiff then said to Mr. Rogers, "I want to stay with you, will you make me an offer?" This was refused, and that was the last heard about employment until the bill was received. Mr. Rogers testified that what the plaintiff had said on the stand pertaining to the conversation alleged to have been held between them was false. Mr. Rogers further stated that Mr. Bristol did not perform any duties at the factory during January that he was aware of. He was not in the employ of the company after the first of that month. Concerning the \$1,918 sale at the factory, Mr. Rogers said the goods were disposed of at a very low price that was far from being satisfactory. Concerning the mail orders, Mr. Rogers said the company had sold to the parties before and since the plaintiff was in their employ. Mr. Rogers stated he would not pay commission for selling a job lot

WATCHES

WHO SAID WATCHES?

Ladies' Watches,  
Gentlemen's Watches,

Railroad Watches.

We Are the Largest Distributors of

Dueber-Hampden Watches

IN NEW YORK.



John N. Pierwood & Co.  
Watches. Chains. Diamonds. Jewelry.

No. 3 MAIDEN LANE, NEW YORK.

# THE DUEBER HERALD

THE ADVOCATE OF HONEST BUSINESS METHODS.  
\* DEVOTED TO THE RETAIL JEWELRY TRADE. \*

Vol. I.

CANTON, OHIO, DECEMBER, 1899.

No. 10.

## A HURRIED WORD.

No time to talk much.

\* \* \*

You're busy waiting on customers.  
Haven't time to read.

\* \* \*

Therefore, only a hurried word:  
Have you seen the new 12-size Due-  
ber Watches ?

\* \* \*

Ever see anything better?

\* \* \*

Also, did you get a copy of the  
new Dueber Catalogue? That's all.

\* \* \*

Wish you a good trade.

## IMPORTANT NOTICE.

The Dueber Herald takes pleasure  
in recording the remarkable success  
of the three new 12-size watches  
placed upon the market by the Due-  
ber-Hampden Works.



“DUEBER WATCH CO.”

## THE LAST CALL.

How's your watch stock?

\* \* \*

Large enough? Good enough?  
Or, does it need embellishing?

\* \* \*

If so, remember the new 12-size  
Dueber Watches. To say nothing  
of “The Four Hundred,” for ladies.

\* \* \*

Don't wait another day.

\* \* \*

The new Dueber Catalogue is de-  
signed to help you. It will, if you  
let it.

\* \* \*

Merry Christmas.



“JOHN HANCOCK.”

The movements  
are made in three  
grades, viz.: The  
“John Hancock,” the  
“Dueber Watch Co.”  
and the “Dueber  
Grand;” and are sold  
only in the 14 and 18  
karat solid gold and 14-  
karat gold-filled cases of the Dueber Watch  
Case Co.

They have been  
voted the handsomest  
and closest-running  
watches ever pro-  
duced. A detailed  
description of their  
merits will be pub-  
lished in a later issue  
of The Dueber Herald.



“DUEBER GRAND.”



*No watch ever  
made has sold as  
well as No 333*

It is the only nickel watch that comes anywhere near the style and beauty of the fine gold cases:

It is 14-size and modeled so that it does not bulge out the pocket:

It has a jeweled movement, is thoroughly tested and carries the same guarantee of accuracy as we give all our watches:

It is the popular size for men, yet not too large for a boy:

Not dead stock at any season—at this season it is *the quickest-selling article a jeweler can handle*:

Arabic, Roman or Card Dial:

**NICKEL OR GUN METAL.**

*New England Watch Co.*  
WATERBURY, CONN.

**No  
333**



at such an unsatisfactory figure as the factory sale referred to.

On cross-examination, Mr. Rogers did not remember very well just what took place last January. He was sick, but did not remember how many days or whether he had a physician. He had been in New York, when, how many times and how long he remained he did not remember. He stated that Mr. Bristol's services had not always been entirely satisfactory, and in answer to Mr. Fay's question as to why plaintiff's salary was raised from \$3,000 to \$3,200 then, Mr. Rogers stated that he would rather pay a man more than he was worth many times than to let him go, especially if he had been with the concern for some time. Mr. Bristol was not satisfactory because he did not sell goods enough. Following Cephas B. Rogers, Gilbert and Wilbur Rogers took the stand. Their testimony was to the effect that Mr. Bristol was not in their employ during January.

The case was adjourned until Saturday morning, when the arguments will be heard.

#### **E. P. Percival to Carry the Case Against Him to the Highest Court.**

PHILADELPHIA, Pa., Dec. 8.—Ebenezer P. Percival, jeweler, 221 N. 8th St., who was in August, 1898, declared guilty of selling watches at private and public sale at Mount Gretna, Pa., without a license, intends to carry his case, which involves questions of the greatest importance to the trade, to the highest tribunal in Pennsylvania, the Supreme Court.

About two weeks ago the Superior Court handed down a decision, published in full in THE CIRCULAR, upholding and sustaining the verdict of the Court of Quarter Sessions of Lebanon county that Percival was guilty. At the instance of

Percival's attorney, Justice Brown granted Tuesday a rule, returnable on Jan. 6 next, to show cause why an appeal should not be allowed in the case of the Commonwealth against Percival, and directed that the rule act as a supersedeas in the meantime. The case was carried to the Supreme Court from the Superior Court to which it had been appealed from the Quarter Sessions Court of Lebanon county. Mr. Percival alleges the ruling of the Superior Court is contrary to the law and that a great injustice has been done him, and that the questions are of sufficient importance to be heard by the Supreme Court.

#### **Alfred Krower Had the Right to Take His Own Goods.**

PROVIDENCE, R. I., Dec. 8.—A non-suit was ordered yesterday by Justice Douglas, in the Common Pleas Division of the Supreme Court, in the case of George T. Harding against Alfred Krower, *et al.* The plaintiff is proprietor of the Novelty Jewelry Co.'s store, corner of Westminster and Battery Sts. The suit was brought as an action of trespass in the sum of \$5,000 against Mr. Krower and Egbert B. Shepard, for taking from the plaintiff's store stick pins and imitation precious stones to the value of about \$100, in June, 1898.

It was claimed for the defense that the goods were the defendants' property and had been taken by an employe, Edward S. Harding, previously, without payment or record appearing on the books. Against

## Exquisite Enamel Watches

FOR THE HOLIDAYS.

THE FINEST ASSORTMENT OF  
DAINTY GOLD AND SILVER EN-  
AMELED WATCHES, ARTISTI-  
CALLY DECORATED, FULL JEW-  
ELED LEVER AND CYLINDER  
ESCAPEMENTS.

Quality Warranted.

**HIPP. DIDISHEIM & BRO.,**

54 MAIDEN LANE, NEW YORK.

CHICAGO OFFICE, CHAMPLAIN BLDG.

# WALTHAM WATCHES

*are the best and best-known watches  
in the world.*



Ralph Waldo Emerson,  
in his Essay on Elo-  
quence said in speak-  
ing of a man whom  
he described as a  
Godsend to his town,  
"He is put together like  
a Waltham Watch."

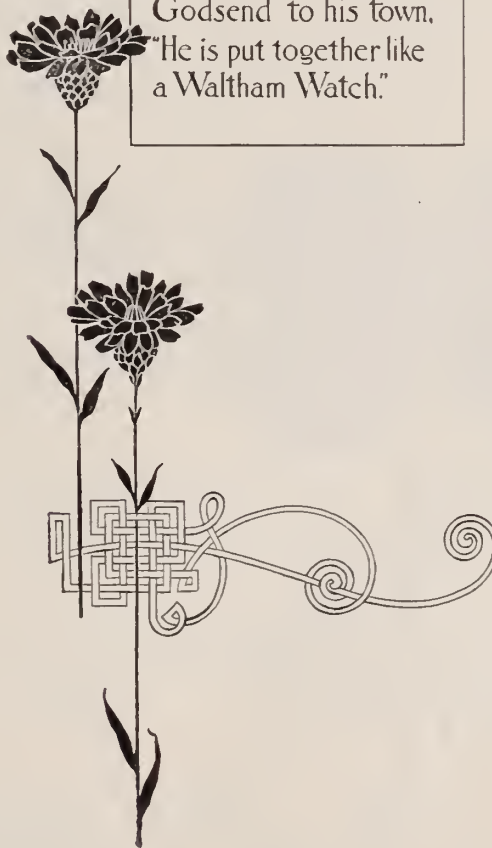

this the plaintiff alleged that all excepting \$24 worth of the stones had been paid for and that in a previous suit Edward S. Harding had been acquitted on a charge of larceny. In ordering the non-suit Justice Douglas ruled the defendants had the right to take away Mr. Krower's property and the plaintiff's property which he had mixed with it.

H. C. Milligan, from Keosauqua, Ia., is placing a stock of jewelry in the McClelland building, New London, Ia.

Richard Robinson, who has represented several eastern manufacturers on the road, has opened a jewelry store in Marion, O.

## The Essential Features

of the high-priced movements  
are all contained in even the  
lowest-priced grades of

### Trenton Watches,

all of them having lever escapements, screw bankings and tempered hair springs. They are the best timekeepers for the price.

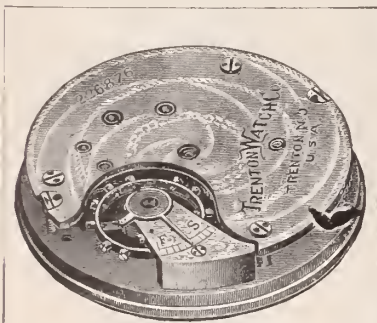

Trenton, 18 Size, No. 7, 7 Jewels,  
Stem-Winding, Lever-Setting, Open  
Face and Hunting.

Trenton Watches are the most desirable for the retail jeweler to handle, as he can sell them at a large profit and still make a contented customer.

SEND FOR PRICE-LIST.

The Trenton Watch Co.,  
Trenton, N. J.

### Canada's "Quadruple Plate" Case

#### The Conviction of T. Eaton Co. for Wrongful Use of the Term Sustained.

TORONTO, Ont., Dec. 9.—On the 5th inst. the case of the Queen *vs.* the Timothy Eaton Co., convicted about a year ago on an indictment for applying a false trade description to goods in advertising a tea set as "quadruple plate," came up before the Divisional Court, at Osgoode Hall, Toronto, upon appeal, a case having been reserved by the trial Judge of the lower court.

The following were the questions reserved: 1. Was the use of the words "quadruple plate" by the defendants in the advertisement an application of a false trade description to goods within the meaning of the fourth count, provided that the goods in question were not and could not be properly described as quadruple plate?

2. Was there evidence to go to the jury that the description "quadruple plate" in the advertisement might refer to the tea set sold to Impey?

The majority of the Judges decided in the affirmative, and the conviction against the Timothy Eaton Co. was consequently sustained.

#### Organization of the Granite State Association of Opticians.

BOSTON, Mass., Dec. 11.—Briggs S. Palmer, president of the New England Association of Opticians, and Albert G. Barber, of the Globe Optical Co., went to Manchester, N. H., last Tuesday, to assist in organizing there what is to be known as the Granite State Association of Opticians. The meeting was held at the New Manchester house, and there were 22 opticians present from representative cities of the State. Letters were also read from several others who favor the project and who will become members of the association. The constitution and by-laws adopted by the participants were modeled upon those of the New England Association, and the following officers were chosen: President, George H. Brown, of Manchester; vice-presidents, J. F. Safford, of Farmington, and Albert Lord, of Tilton; chairman of directors, C. F. Hussey, of Portsmouth.

Ed. Busse, jeweler with Rush & Smith, Mt. Carmel, Ill., was married at Vincennes a few days ago to Miss Hartman.

#### More Awards at the National Export Exposition.

PHILADELPHIA, Pa., Dec. 9.—The following additional awards of silver medals have been made by the jury of awards of the National Export Exposition:

Silver medal, the highest, for philosophical, optical and mathematical instruments, to the following firms: National Optical Co., 11th and Mifflin Sts., Philadelphia; Loughlin-Hough Co., New York city; Williams, Brown & Earle, 917 Chestnut St.; Keystone Scale Works, Limited, Philadelphia, and Fauth & Co., Washington, D. C.

Robert H. Ingersoll & Bro., New York, were awarded a silver medal for timepieces and recording apparatus.

#### Creditors of David F. Conover & Co. Called Upon to Meet.

PHILADELPHIA, Pa., Dec. 10.—The first meeting of the creditors of B. Frank Williams, who traded under the firm name of David F. Conover & Co., an old and at one time wealthy wholesale jewelry establishment, and who was duly adjudicated a bankrupt, Nov. 28 last, has been called for Monday, Dec. 13, at 3 o'clock p. m., at the office of Edward F. Hoffman, referee in bankruptcy, 560 Bullitt building. The creditors have been notified "to attend, appoint a trustee, examine the bankrupt and transact such other business as may properly come before the meeting."

#### Details of the Robbery of the Jewelry Stores in the Arcade, Cincinnati.

CINCINNATI, O., Dec. 9.—The mystery surrounding the burglarizing of the stores of the Arcade jewelers, as reported in the last issue of THE CIRCULAR, increases as the investigation progresses. The burglars entered S. B. Duncan's store first through a bull's-eye window in the rear, as footprints were found on the safe right under the window. They showed expertness by taking from the trays left out the gold jewelry, leaving the plated. Several packages of new goods just received by the firm which had not been opened yet were carried off. The cash register was taken to the basement and rifled. After effecting an entrance into L. F. E. Hummel's store, they were too frightened to go above, and only plundered in the basement, their haul here being not of much value. The fact that the places are both opposite the entrance to the Emery hotel and that an electric light was burning all night making the interior of Hummel's store light as day possibly prevented a bigger haul.

We have made a specialty of

## FINE FINGER RINGS

for more than half a century.

## GEO. O. STREET & SONS,

24 JOHN ST., NEW YORK.

... Established 1837 ...



**Daniel Earl Fails Promptly After His Reported Robbery.**

CHICAGO, Ill., Dec. 9.—Daniel Earl, diamond merchant, 126 State St., who claimed he was robbed on the street Nov. 25 of a wallet containing a large number of precious stones, has filed in the United States Court for the Northern District of Illinois a petition in bankruptcy. The petition reveals that Daniel Earl was also known to a number of New York diamond dealers back in 1888, under the name of Augustus C. Radcliffe, and that the New Yorkers hold promissory notes aggregating \$17,050, signed by Radcliffe, alias Earl. Another fact is revealed by the petition, namely, that his reported loss of between \$6,000 and \$7,000 took all but \$173.48 of the victim's stock. There is not lacking abundant criticism of a man who will put practically all of his earthly possessions in an outer overcoat pocket and then venture out on a crowded Chicago street. The petition in bankruptcy covers Mr. Earl's debts as Daniel Earl and also the debts he contracted in 1888, under the name of Augustus C. Radcliffe, and shows the following indebtedness:

Contracted in name of Augustus C. Radcliffe: Simon Dessau, April, 1888, promissory note with interest, \$2,700; D. L. Van Moppes, June, 1888, promissory note with interest, \$10,200; Henry Fera, June, 1888, promissory note with interest, \$2,800; J. G. Doty, July, 1888, promissory note with interest, \$700; J. Haas, July, 1888, promissory note with interest, \$650. Contracted in name of Daniel Earl: Albert Lorsch, three promissory notes, April 10, 1899, aggregating \$2,137; L. Heller & Son, note Aug. 31, 1899, \$259; M. R. Cobb, book account, Nov. 18, 1899, \$53; estate of D. E. Camerer, house rent, \$162; S. Lyons & Son, note, Aug. 21, 1899, \$356; Stein & Ellbogen Co., note, Oct. 14, 1899, \$441; Robert Beygeh & Bro., book account, Nov. 6, 1899, \$673; S. Buchsbaum & Co., note, Nov. 14, 1899, \$612; Union Central Ins. Co., note, Sept. 15, 1899, \$261; miscellaneous book accounts, Nov. 3 to Nov. 18, \$309; total indebtedness, \$22,313. Against this unsecured indebtedness there are assets of \$395, as follows: Stock in trade in place of business, \$173.48; household goods, \$130; wearing apparel, \$60; ornaments, \$20; books and pictures, \$12; total assets, \$395.48. Of the assets the major portion is exempt.

**Death of a Picturesque Attleboro Character.**

ATTLEBORO, Mass., Dec. 11.—Ernest C. H. Myers, one of the pioneer jewelry polishers and one of the most picturesque characters of the Attleboro of old days, died last week at his home. Myers was a native of Mecklenberg-Schwerin and a veteran of the German army. He saw hard campaigning in the Danish war, in the King's Guards, a regiment made up of men all over six feet high. His stature was six feet five inches, and even in old age his figure was one of great manly beauty, so that he was a conspicuous person whenever he appeared upon the street. After the war he came to this country, landing at New York with a blanket and 73 cents. After four years of hard work he reached New York again, having trav-



**NOW WHEN YOU RECEIVE A SPECIAL ORDER...**

*for something you may not just have in stock—a fine watch or piece of jewelry or some loose diamonds—write or wire us. Goods by return express—you can depend on it. Many jewelers know this by experience. We should also like to demonstrate it to you.*

**HENRY FREUND & BRO.,**  
11 Maiden Lane, NEW YORK.

**ELK GOODS A SPECIALTY.**

**S. STERNAU & CO.,**  
204 CHURCH STREET, NEW YORK.

Manufacturers of **METAL WARES**  
in Brass, Copper and Silver.

**CHAFING DISHES, KETTLES, TRAYS,**  
Crumb Trays and Scrapers. Bread Baskets, Etc.

CATALOGUE ON APPLICATION.



The **Leader**  
...IN...  
**HIGH GRADE WATCHES**  
—IS THE—  
**VACHERON & CONSTANTIN,**  
GENEVA, SWITZERLAND.

FIRST in { Quality, Adjustment, Durability, Style.

{ FITS ALL SIZES OF AMERICAN CASES. } **NEW** GRADES SIZES IMPROVEMENTS. { SPECIAL GRADES FOR RAILROAD MEN.

**EDMOND E. ROBERT,** 3 Maiden Lane,  
SOLE AGENT, **New York.**



## "THE AMERICAN BEAUTY"



### Sterling and Essex Gold Filled.

UNEQUALED.

PRICE, \$2.00. FOR SALE BY ALL JOBBERS.

**Hayden Mfg. Co.,**  
**21-23 MAIDEN LANE,**  
**NEW YORK.**

ersed Cuba, the south and the central west. He was taken with yellow fever in New York, and was later discharged cured from a hospital, but this time he walked the streets with no blanket nor 73 cents. He entered an intelligence office and found the older E. Ira Richards, of North Attleboro, so eager for men that he would hire anyone who was willing to try his hand at polishing. Myers followed him home and for years pursued the trade.

Myers went to the war with the 24th Massachusetts. He was drum major of the famous Gilmore's Band, which accompanied the regiment, and in his magnificent dress towered nine feet two inches high from the floor to the tip of the plume on his bearskin. He returned to the bench, but at last age debarred him from work, and loving children afforded him a happy retreat from labor. He was buried Saturday by William A. Streeter Grand Army Post.

#### **Jeweler's Wife at the Point of a Revolver Foils Three Would-Be Thieves.**

CHICAGO, Ill., Dec. 9.—Mrs. Arnold Strassburger, wife of a jeweler at 483 Lincoln Ave., by her nerve and presence of mind this week foiled two men and a woman who attempted to rob the store of diamonds. The strangers went in and asked to see some diamond rings. Her husband was away, and she herself took out the tray, containing about 100 rings, and the men began to try them on the woman. She claims that instead of putting the rings back in the tray, they substituted imitation diamond rings. She detected the fraud after several rings had been taken, and, reaching under the counter, she drew a revolver, and said: "What kind of a game is this you are playing? Just put those rings back." The men were completely cowed and began returning the rings to the tray. One of them dropped a ring on the floor, and at the point of the revolver she made him pick it up. Then, after she had carefully counted her property and seen that it was all there, she allowed the men to go, as there was no one else in the house and she had no way of communicating with the police.

They had the appearance of well-to-do people, said Mrs. Strassburger to THE CIRCULAR representative. One of the men was about five feet six inches tall, medium complexion, smooth shaven, and would weigh about 160 pounds. The other man was about five feet nine inches, dark complexion, smooth face, and a little heavier in build than the shorter man. The woman was dark complexioned and about five feet four or five inches, and would weigh about 125 pounds.

Skillman, Vanderveer & Williams, Trenton, N. J., announce that they are about to give up the retail business and stick to their old business of manufacturing jewelry. They are conducting an auction sale.

John Lamonthé, the victim of an accident at the works of the American Optical Co., Southbridge, Mass., a couple of weeks ago, when a heavy press tipped over and crushed him, died at the Worcester hospital from the effects of his injuries. He was 43 years of age.

#### **Death of Reinhold Siedle.**

PITTSBURGH, Pa., Dec. 9.—Reinhold Siedle, who was the oldest business man on Fifth Ave., this city, so far as years given over to business are counted, died on Wednesday, Nov. 6, at the family residence, 4610 Forbes Ave. Mr. Siedle was the head of R. Siedle & Sons.

Mr. Siedle was born in Furtwangen, Germany, April 5, 1829, and came to

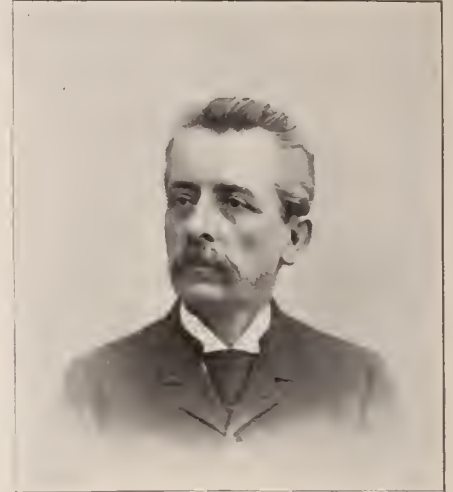

THE LATE REINHOLD SIEDLE.

America in 1847 and settled in Pittsburgh, where he has resided ever since. In 1849 he formed a partnership with his brother-in-law, H. C. Reineman, in the jewelry business, under the firm name of Reineman & Siedle. Mr. Reineman retired in 1855, and in 1861 Louis Reineman and Charles Meyran became partners in the business, and the firm name was changed to Reineman, Meyran & Siedle. Mr. Reineman retired in 1869, and Mr. Meyran in 1873. Mr. Siedle continued the business until 1889, when his two sons, William R. and Oscar C. Siedle, were taken into the firm. The new firm were thereafter known as R. Siedle & Sons.

Mr. Siedle was married in 1849 to Miss Catherine Elizabeth Reineman, who, with four sons, Charles H., Albert R., William R. and Oscar C., survives. He was an uncle of Oscar Ganter, jeweler. The funeral services were held to-day at his late home and the interment occurred in Homewood Cemetery. Mr. Siedle was a man of rare business qualities, of sterling integrity, and was one of the foremost business men of Pittsburgh. His death is deeply deplored by his many friends.

Capt. Harry L. Archer has purchased an interest in Lieut. A. S. Wadsworth's jewelry establishment, Beatrice, Neb., and the firm will hereafter be known as Wadsworth & Archer. The new arrangement went into effect Dec. 1. Lieut. Wadsworth is still in the hospital at San Francisco, but hopes to be home soon, the wound in his leg improving slowly. He went to the Philippines as first sergeant of the Beatrice company and came back as second lieutenant of B Company at Fullerton. Archer went out as first lieutenant of the Beatrice company.



# Our Traveling Representatives



Traveling representatives may consider these columns open for the publication of any news or items of interest regarding themselves or their confreres.

## Eastern Travelers Recreates.

PROVIDENCE, R. I., Dec. 8.—The Manufacturing Jewelers' Salesmen's Association held their first social gathering of the present Winter season last evening in their rooms in the Fletcher building, corner of Union and Weybosset Sts.

There was a good attendance of members and a number of friends of the association were also present. The entertainment was an informal affair given in the form of a smoker with plenty of refreshments. Prof. Arthur C. Moore added to the pleasure of the occasion with some of his banjo solos, and under his leadership the Washburn Banjo, Guitar and Mandolin Club played several selections. Thomas U. Catlow gave a highly amusing caricature of Sousa leading his band, while Joseph Catlow, the former's partner in the firm of Catlow Bros., sang songs in excellent voice. W. L. Brewer sang negro melodies and "rag time" songs in his clever manner, James T. Franey gave readings in a finished manner and Messrs. Hunter and Abbott rendered selections. Fred Mack again gave his remarkable exhibition of skill on the piano, and the entertainment closed with an Oriental dance by the inimitable Claricino. The committee in charge of the successful event consisted of W. L. Brewer and Thomas U. Catlow. Previous to the social session a short business meeting was held and W. A. Cook, of Fontneau & Cook, Attleboro Falls, and Mr. Major, salesman for W. H. Luther & Son, were elected active members of the association, and C. L. Valentine, who is with Thomas W. Lind, was elected an associate member. Another business meeting will be held on Thursday evening, Dec. 21.

James Brown, for George B. Barrett & Co., Pittsburgh, Pa., will return this week from his trip and will remain until after the holidays.

The jewelers of Portland, Ore., were interviewed during the past week by Jno. O. Slemmons, representing J. B. Bowden & Co., New York; and Hugo Low, Low, Weinberg & Co., New York.

Among the travelers in Kansas City, Mo., last week were: E. A. Reed, Reed & Barton; J. Rothschild, Ingomar Goldsmith & Co.; Otto Sinauer, Oppenheimer Bros. & Veith.

James Brennan started out on his initial trip for E. A. Dayton & Co., Omaha, Neb., last week, he having been promoted from the position of material clerk. Frank Newcomb has just returned from a prosperous trip through Missouri and Kansas for Sol Bergman & Co., Omaha.

The following traveling salesmen passed through Detroit, Mich., last week: Mr. Waugh, E. Kirstein's Sons Co.; W. S. Noon, W. F. Cory & Bro.; Fred J. Foster, Unger Bros.; M. F. Thornton, Edward Todd & Co.; Charles Lochner, Hayes Bros., and Mr. Smith, Smith & North.

Travelers in Pittsburgh, Pa., last week were: J. F. Dean, Reed & Barton; G. E. Tinker, Wm. B. Durgin Co.; Fred Clarkson, Albert Lorsch & Co.; I. Arnstein, Arnstein Bros. & Co.; William S. Manheimer, Atlas Watch Co.; Charles A. Whiting, Whiting & Davis; Mr. Heiser, H. C. Hardy & Co.

F. J. Wirtz, representing F. A. Hardy & Co., Chicago, was in Omaha, Neb., last Thursday. He has been with the house nine years, traveling for it four years. One year ago he was given this territory, taking the place of J. C. Hutson, who established himself in the optical business in Omaha.

C. D. Maughan, traveling representative of the Goldsmiths Stock Co., Toronto, who has just returned from a trip to the Maritime Provinces, reports business brisk and a good demand for staples and novelties. The advent of the firm of Barre Bros. Co., lately of Winnipeg, has induced keen competition in the Halifax trade, the newcomers having introduced the principle of strictly cash sales and smaller profits.

Recent traveling men in Omaha, Neb., were: M. Wolfe, for Fred Kaufman; Charles Lochner, Hayes Bros.; Louis E. Fay, D. Wilcox & Co.; W. S. Sparrow, Stern Bros. & Co.; Thomas E. Rogers, Riker Bros.; F. D. Smith, N. E. Whiteside & Co.; F. R. Horton, Carter, Hastings & Howe; J. Patterson, Geneva Optical Co.; E. A. Reed, Reed & Barton; A. Barker Snow, Snow & Westcott.

Travelers in St. Louis, Mo., last week were: J. Rothschild, Ingomar Goldsmith & Co.; E. W. Brannon, John W. Reddall & Co.; H. J. Fink, for David Marx; Ben. Eichberg, Eichberg & Co.; R. G. Monroe, for Wm. Scheer; J. E. Simonson, A. J. Hedges & Co.; Wm. Hofer, M. A. Mead & Co.; W. C. Barry, Larter, Eleox & Co.; L. P. Buller, Heintz Bros.; Arthur A. Wheeler, for Louis W. Hrabka; E. J. Roehr, Bassett Jewelry Co.; Stephen Woods, Woods & Chatellier; Herbert W. Van Houten, for C. Sydney Smith; W. H. Bryant, T. G. Hawkes & Co.; S. B. Kent, Wm. H. Ball & Co.

## Connecticut.

The Ruddy Jewelry & Optical Co., New London, have made several advantageous changes in their store.

Samuel Barry, who travels south in the interest of the International Silver Co., returned last Tuesday to Middletown.

The E. T. Burgess Cut Glass Co., Middletown, have decided to wind up their affairs and go out of business. This is because of their inability to secure a place suitable for their business.

John B. Kendrick, accountant and auditor, has opened an office in Room 40, Sage-Allen building, New Haven. Mr. Kendrick is an expert accountant and was for years the auditor of Simpson, Hall, Miller & Co., Wallingford.

The Miller Bros.' Cutlery Co., Meriden, have sued the city of Meriden for \$17,500 damages for obstructions placed in the water supply system of the company and because the water was diverted from the shops in changing the grade of certain streets. The suit is returned to the December term of the Superior Court.

## Bangor, Me.

### TRADE CONDITIONS.

The trade conditions among the jewelers here for Christmas are particularly bright, and all of them have planned for a big business. The Bangor jewelers' trade in sterling silver has been cut into considerably during the past year by the addition of silver ware departments by some of the large book stores and dry goods establishments. The Bangor jewelers have bought large stocks of clocks, watches, silver ware and gems for the holiday trade.

W. E. Clendennin, of Winn, Me., has entered the Waltham Horological School, Waltham, Mass., to take a course in watchmaking.

Frank H. Woodbury, Gardiner, Me., has a ring which is quite a novelty. It is made wholly of Maine material. The gold was taken from a mine in East Pittston and is very fine. The stone is a tourmaline which was found at Mt. Mica. The ring with the setting was made by Mr. Woodbury and is probably the first piece of jewelry which was entirely made from Maine product.

A secret marriage, which took place May 16, came to light in Evansville, Ind., Dec. 3, when I. Herman Haas was sued for divorce. He is a dentist and a member of a prominent family. His wife was Nellie May Bittrolff, daughter of a leading jeweler.

STERLING SILVER GOODS ONLY



FRANK M. WHITING & CO.  
SILVERSMITHS  
NORTH ATTLEBORO MASS  
1128 B'WAY, NEW YORK.  
220 SUTTER ST. SAN FRANCISCO.

## CONSULT

"The New York Jeweler"

Before Buying Jewelry or Kindred Lines.

For 26 years the acknowledged authority for all that is new, artistic and beautiful in the Jewelry World.



An idea of the assortments illustrated is shown by the fact that there are over 1000 Designs in Diamond Jewelry; 2000 Designs in Watches; 3000 Designs in Emblems; 5000 Designs in Gold and Silver Novelties; and proportionate displays from our Silverware, Clock, Cut Glass, Lamp, Musical, Photographic, Optical, Scientific Instrument, Leather and Fine Stationery Departments.

724 Pages. Size, 9 x 13.

This profusely illustrated catalogue enables the dealer to make a better selection than the majority of travelers' stocks affords.

S. F. MYERS CO.,

MANUFACTURING and WHOLESALE JEWELERS

Myers Building, 48-50 Maiden Lane, New York.

Mention Dept. G 12 when sending for catalogue.

# Control Your Own Watch Cases.

You can control your own designs and in other ways receive valuable assistance that will enable you to avoid competition and increase your profits if you handle Bell Gold-Filled Watch Cases.

Write for particulars.



Any monogram, emblem, special design, portrait, etc., you can have engraved on a watch case when you

Buy of the Maker.

**THE BELL WATCH CASE CO.,**

CINCINNATI, OHIO.

### Importations at the Port of New York.

*Weeks Ended Dec. 9, 1898, and Dec. 8, 1899.*

China, Glass and Earthen Ware:	1898.	1899.
China .....	\$49,214	\$67,866
Earthen ware .....	17,709	28,407
Glass ware .....	14,357	21,204
Optical glass .....	not recorded	167
Instruments:		
Musical .....	9,231	23,366
Optical .....	9,724	6,714
Philosophical .....	596	752
Jewelry, etc.:		
Jewelry .....	1,306	6,114
Precious stones .....	55,578	281,407
Watches .....	19,945	24,875
Metals, etc.:		
Bronzes .....	2,040	1,366
Cutlery .....	10,989	15,004
Dutch metal .....	2,221	9,928
Platina .....	14,954	19,350
Plated ware .....		1,184
Silver ware .....	5,037	1,208
Miscellaneous:		
Alabaster ornaments .....	835	3
Amber .....	42	7,747
Beads .....	1,109	2,348
Clocks .....	7,303	5,913
Fans .....	11,317	14,585
Fancy goods .....	5,442	9,547
Ivory .....	4,353	31,762
Ivory, manufactures of .....	567	1,181
Marble, manufactures of .....	7,042	14,875
Statuary .....	1,471	4,185

### Jewelers' Gold Bars Withdrawn and Exchanged.

*Week Ended Dec. 9, 1899.*

The U. S. Assay Office report:

Gold bars exchanged for gold coin.....	\$191,322.86
Gold bars paid depositors.....	53,184.76
Total .....	\$244,507.62

Of this the gold bars exchanged for gold coin is reported by the Sub-Treasury as follows:

Dec. 4.....	\$44,984
" 5.....	26,139
" 6.....	20,670
" 7.....	37,204
" 8.....	26,400
" 9.....	15,345
Total .....	\$170,742

C. M. Woodhouse, Springer, N. M., is out of business.

Last May a sneak thief entered J. K. Stebbins's jewelry store, Ashtabula, O., and got away with a gold watch and opal stick pin. He was lately captured in Buffalo and taken to Jefferson jail, where a few weeks ago he was sentenced to serve one year in the penitentiary at Columbus. The police in Buffalo have been watching for the goods, and they a few days ago were located in a pawnshop in that city.

### Trial of the Case Against the "Montana Diamond Co."

BOSTON, Mass., Dec. 11.—The "Montana Diamond Co." case came up by continuance Friday in the Municipal Court before Judge Dewey. Much of the time was taken up in legal sparring by counsel, but it was brought out at the hearing that the so-called gems sold by the defendants, Hirshfield and Weiner, clerks for the concern, were really a superior quality of glass. I. M. Jacobs, head of the company, came on from New York to testify as an expert.

A "Montana diamond" was offered in evidence, and the witness was asked to explain what it was. Objection was made, and Judge Dewey sustained the objection, saying: "It doesn't make any difference what a 'Montana diamond' is. The question is, what were the stones which were bought." A scaripin put in evidence was then called for by defendants' lawyer, and witness Jacobs identified the substance as a "Montana diamond." He said that the imitation was made of silver, mined in the earth, and compounded with oxide of lead, potash, etc., over 60 per cent of the compound being silver. He was questioned about the sign in the company's window, which says that Montana diamonds will stand all the tests of a real diamond, and he said they would stand some of the tests, the usual acid and would cut glass, although not so well as a real diamond. He admitted that ordinary window glass would contain about as much silica as the "Montana diamonds." On cross-examination the witness was asked:

"Isn't it a fact that your 'diamonds' are nothing more than a hard kind of window glass?" Ans.—"Well, you could term it that way."

"As a matter of fact, the material of which these 'Montana diamonds' are made is put in a pot and melted together, isn't it?" Ans.—"Yes, amalgamated."

To-day (Monday) the hearing was resumed. Judge Dewey took occasion to remark that in view of the admissions of Mr. Jacobs on Friday he could see little reason for prolonging the hearing. He patiently permitted the defense to continue, however, and at the close found the two salesmen guilty on each of the four counts brought against them, imposing a fine on each count for each defendant of \$5.

The fines were paid and the men were released.



"Watch Our Ads."

**THE MAUSER MFG. COMPANY,**  
SILVERSMITHS,

15th St., bet. Broadway and Fifth Ave., New York.

HEADQUARTERS FOR  
JEWELERS'  
AND  
SILVERSMITHS'

**MACHINERY**

DROP PRESSES,  
FOOT PRESSES,  
SCREW PRESSES,  
POWER PRESSES,  
ROLLING MILLS.

WESTERN OFFICE,  
MERCANTILE BANK BLDG.,  
CLEVELAND, OHIO.

MOSSBERG & GRANVILLE MFG. CO.,  
PROVIDENCE, R. I.

NEW YORK OFFICE,  
126 LIBERTY ST.

**Views as to the Commercial Status of Drilled Pearls.**

Further testimony upon the commercial status of drilled pearls was taken before a referee in the Post Office building, New York, Wednesday. This testimony, like that of Geo. F. Kunz, told in THE CIRCULAR of Nov. 22, is to be introduced in a suit by Tiffany & Co. against the United States that will come before the United States Circuit Court within a few weeks. The action in question is an appeal from a decision by the Board of General Appraisers which resulted in the assessment of duty at 20 per cent on pearls drilled and

not strung. The importers claim that the pearls should be assessed at 10 per cent under the paragraph providing for "pearls in their natural state."

Among the witnesses examined Wednesday were: Fred. W. Lewis, of Fred. W. Lewis & Co.; Henry B. Billings, of Chester Billings & Son; Simon Frankel, of Jos. Frankel's Sons; J. Howard, of Howard & Co.; E. P. Benedict, of Benedict Bros.; Alfred H. Smith, of Alfred H. Smith & Co., and United States Jewelry Examiner Geo. W. Mindil. These gentlemen testified as to the commercial meaning of "pearls in their natural state," some claim-

ing that drilled pearls are considered commercially as pearls in their natural state, while others insisted that they are not.

J. E. Jahnke, optician, Chattanooga, Tenn., who has been seriously ill, is reported getting better. Early recovery is now hoped for.

F. P. D'Arcy has decided to move his manufacturing plant from Kalamazoo, Mich., to Zanesville, O., and will add it to his jewelry business there. He will do a wholesale business.

# AS YOU KNOW,

There are  
**Watch Houses**  
and **Watch Houses**  
and **Watch Houses**

## **GOOD—BETTER—BEST.**

**WHEN** there are more than two thousand dealers, those who carry good large stocks, who assert that we are the **BEST WATCH HOUSE**, they must have their reasons for saying so.

**NOW** we have to say, that we are willing to have the number of dealers doubled who accord us this distinction.

*1899 will soon have passed into History.*

*1900 has a bright outlook before it.*

Our watch plans have in them **much** that may be of interest and profit to you.

### **C. G. ALFORD & CO.,**

**195-197 BROADWAY,**

**NEW YORK.**

# A Short Talk With Jewelers

You are no doubt aware that a number of Manufacturers of Silver Ware are catering largely to the Dry Goods and Department Stores, and that the latter are distributing their Catalogues broadcast throughout the country, and that many of them enter the homes of your customers. If you have these goods represented in your stock this cheapens and lowers them in the estimation of your customers, as a person who is desirous of making a wedding anniversary or birthday gift of an article of Silver Ware, and by so doing expressing his regard for the recipient by bestowing an article of value, would feel reluctant to present an article for such occasion identical with those illustrated in a Dry Goods Circular. Therefore, is it not for your interests to confine your purchases to those Manufacturers who place their goods only through the legitimate Jewelry trade, and who refuse to supply them to the Dry Goods and Department Stores?

It is not enough that a manufacturer does not sell a Dry Goods house in YOUR City, for these Catalogues go to every large city and small town, and your competition is just as direct with the Dry Goods Catalogue, as though the manufacturer supplied a Dry Goods Store in your own city. The GORHAM MFG. COMPANY have for years pursued the policy of confining the sales of their wares to the legitimate Jewelry trade, and their customers are absolutely free from the charge of carrying Dry Goods silver ware in their stocks, and in addition to this the articles are more exclusive and refined, the finish and workmanship better, and the prices no higher.



## Gorham Mfg. Co.,

...SILVERSMITHS...

Broadway and  
19th Street,  New York.

BRANCHES:

NEW YORK:  
21 & 23 Maiden Lane.

CHICAGO:  
131-137 Wabash Avenue.

SAN FRANCISCO:  
118-120 Sutter Street.

WORKS: PROVIDENCE, R. I., AND NEW YORK CITY.

# The Jewelers' Circular

AND  
HOROLOGICAL REVIEW.

PUBLISHED EVERY WEDNESDAY BY  
**THE JEWELERS' CIRCULAR PUB'G CO.,**  
DORBIN BUILDING, 11 JOHN ST., COR. BROADWAY,  
NEW YORK.

TELEPHONE:  
1146 CORTLANDT.

CABLE ADDRESS:  
JEWELAR, NEW YORK.

A JOURNAL DEVOTED TO THE INTERESTS OF JEWELERS,  
WATCHMAKERS, SILVERSMITHS, ELECTRO-PLATE MANU-  
FACTURERS, AND ALL ENGAGED IN KINDRED BRANCHES OF  
INDUSTRY.

## Member of the American Trade Press Association.

Our editorial columns will contain our own opinions only, and we shall present in other columns only what we consider of interest or value to our readers. Advertising matter will not be printed as news.

Advertising rates in THE CIRCULAR are lower, considering the number of tradesmen reached by its large circulation, than in any other jewelry journal.

Notices of changes in standing advertisements must be received one week in advance; new matter can be received up to Monday.

## INFORMATION FOR SUBSCRIBERS.

### Terms of Subscription, Postage Prepaid.

	PER ANNUM
United States and Canada, - - -	\$2.00
Foreign Countries in Postal Union, - - -	4.00
Single Copies, - - -	.10

New Subscribers can commence at any time.

Payments for THE CIRCULAR, when sent by mail, should be made in a Post-Office Money Order, Bank Check or Draft, or an Express Money Order or Registered Letter. All postmasters are required to register letters whenever requested to do so.

Pay money only to authorized collectors having proper credentials.

**Returning Copies.** Returning your paper will not enable us to discontinue it, as we cannot find your name on our books unless your address is given.

**Changing Address.** In changing address always give the old as well as the new one. Your name cannot be found on our books unless this is done.

**Discontinuances.** We will continue to send papers until there is a specific order to stop, in connection with which all arrearages must be paid; but such an order can be given at any time, to take effect at or after the expiration of the subscription. All such orders will be promptly acknowledged by mail.

**Liability.** The courts have decided that all subscribers to journals are responsible until arrearages are paid in full and an order to discontinue has been received by the publisher.

## THE JEWELERS' CIRCULAR IN EUROPE.

Among the places in Europe where THE JEWELERS' CIRCULAR is on file are the following:

**LONDON**—First Ave. Hotel, Holborn, E. C.; Holborn Viaduct Hotel, Royal Hotel.

**PARIS**—Hotel de L'Athene, Rue Scribe.

**LEIPZIG**—Handels-Zeitung, für die gesamte Uhren-Industrie.

**BERLIN**—Deutsche Uhrmacher Zeitung, Jäger-Strasse, 73.

**GENEVA**—Journal Suisse D'Horlogerie.

**AMSTERDAM**—Continental Club, Hotel Amstel.

**ANTWERP**—Diamond Club, Rue de Pelican.

Vol. XXXIX. Dec. 13, 1899. No. 20.

*Every line of reading matter in THE JEWELERS' CIRCULAR, with the exception of the few brief extracts from exchanges, always properly credited, is written exclusively for this journal. Each issue of THE JEWELERS' CIRCULAR is copyrighted. Permission to quote is extended to other publications provided such quotations are properly credited.*

It is a gigantic enterprise that Henry A. Spaulding proposes that the city of New York should undertake, but if the scheme were carried out to its full extent the direct financial benefit to the community as having one of the great attractions of the world to tourists would more than compensate for the outlay, while the educational benefit to the people of the entire country would be illimitable.

THE American Trade Press Association, in co-operating with Postmaster Van Cott, of New York, in the agitation for an additional post office building to relieve the great congestion of the present postal service in that city, have formulated resolutions to be sent to the proper authorities, in which are offered several strong reasons why such an addition should be made to the facilities. Of mail matter, a severe sufferer is the second class matter, which includes newspapers. It is safe to assert that delays in the receipt of newspapers are more the fault of the overcrowded and inadequate service than of the publisher's tardiness in delivering his papers at the post office. The whole country suffers by these conditions, which would be considerably ameliorated by the passage of the bill for the erection of a new post office in New York, about to be introduced in Congress.

## The Souvenir Emblem Pin a Coming Fad?

THERE have been few if any fads connected with the jewelry trade that have had such a long and triumphant career as the souvenir spoon. Conceived in this country about nine years ago, the popularity of the souvenir spoon spread like wildfire, and those jewelers who were early in the field with patented emblematic designs reaped a goodly harvest of dollars. Within a year every city or town throughout the country was represented by at least one spoon symbolical of its history, its noted personage or its industrial characteristics. The fad has continued till to-day, though it is well past its zenith. It has found manifestations other than those relating to its initial significance; and as symbols of organizations, of national and municipal events, of persons before the public eye, of expositions and shows generally, the spoon promises to continue for all time; but as a sentimental emblem in metal of a city or town, or of a State, it has seen its best days. Jewelers, therefore, are naturally interested in any sign that points toward the legitimate successor of the spoon. Such a sign is the souvenir emblem pin of Louisiana, to be placed before the public by a well known firm of New Orleans retail jewelers, whose scheme for obtaining the design was a decidedly profitable one to all concerned. By offering a prize to the members of an art school, the jewelers gave a stimulus to extra endeavor on the part of the students to bring out their native talent, which was profitable to them, even if they did not win the prize; while the many designs submitted gave the jewelers an opportunity for a fine selection. A black and white, enlarged representation and a description of the winning design are given on another page of this issue. Who would

be surprised if this would prove the beginning of a pretty fad of the people, profitable to the retail and manufacturing jewelers?

## The Jewelers' Trust and Safe Deposit Companies Maturing.

The movement to establish a trust and a safe deposit company in the jewelry trade of New York, full details of which have already been published in THE CIRCULAR, is making rapid progress, and the organization of the two companies is only a question of very short time. One of the delays with which the promoters had to contend was due to the difficulty of selecting a president that would be prominent in the financial world and at the same time unite and harmonize all interests. This question has now been satisfactorily settled by the selection of Chas. M. Inglis as president of the Sterling Trust Co. Mr. Inglis late last week agreed to accept this position and will be elected as soon as the company is organized.

Augustus K. Sloan, who is prominent in the movement to organize these companies, stated Monday that no president has yet been decided on for the safe deposit company. This, however, is not of so much importance, as the two concerns will be practically under the same management. Both companies will be incorporated under the New York laws.

## Reminiscence of the Many Swindles of Abe Rothchild.

CINCINNATI, O., Dec. 9.—The case of Oskamp, Natli & Co. against the Southern Express Co. was argued in the Supreme Court to-day. The case has gone from one court to another, the express company gaining the decision in one court and the jewelers in another, until the case has reached the Supreme Court.

It will be remembered that Abe Rothchild ordered expensive jewelry from many jewelers throughout the country from various cities, under the name of some rich and prominent citizen of those places respectively. From Hopkinsville, Ky., he ordered under the name of T. M. Jones, a prominent and wealthy citizen of that place, some diamonds from Oskamp, Nolting & Co., and the order was filled by the firm. It developed later, of course, that the real Jones had had no connection with the transaction, and the jewelry firm sued the express company for delivering the diamonds to Rothchild instead of to the real Jones, to whom they were directed. It will also be remembered that Rothchild was arrested promptly through the publication in THE JEWELERS' CIRCULAR of his methods and the general form of the letter which he sent to the various jewelers. Thos. Lees, Hamilton, Ont., who had read the matter in THE CIRCULAR, caused his arrest.

Articles of incorporation were filed Dec. 2 with the Register of Deeds in Milwaukee, Wis., for the Milwaukee Optical Mfg. Co. Among the incorporators are the names of Hiram J. Smith and J. M. Webster, of Racine. Mr. Webster, who has been with the Elkins Jewelry & Music Co. for the past five years, will have charge of the business.

**BUYERS' INFORMATION BUREAU.**

Questions as to the makers of certain lines of goods, where to buy certain lines, where certain kinds of work are done, the owners of certain trade-marks and other matters relating to the buying branch of a jewelry business will be cheerfully answered under this department. The reader cannot ask too many questions.

NEW YORK, Dec. 5, 1899.  
 Editor of THE JEWELERS' CIRCULAR:  
 Where can we get Joseph Jefferson souvenir spoons?  
 THE NEVIUS COMPANY.  
 ANSWER:—W. H. Williams & Son, 12 N. Pearl St., Albany, N. Y.

LOS ANGELES, Cal., Nov. 29, 1899.  
 Editor of THE JEWELERS' CIRCULAR:  
 Can you inform us where we can get lap wheels and grindstones, such as are used for cutting and polishing jewel stones, agates, quartz, etc.?  
 Yours truly,  
 J. A. McINTOSH & Co.  
 ANSWER:—Correspondents can get lap wheels from Colville Lead Co., 63 Centre St., New York, and grindstones from Jno. McCroden & Co., 58 Washington St., New York.

SALINA, Kan., Nov. 27, 1899.  
 Editor of THE JEWELERS' CIRCULAR:  
 Can you inform me where I can get transparent paper in imitation of stained glass? By giving me the above information you will very much oblige,  
 Yours truly,  
 S. J. STRICKLER.  
 ANSWER:—Palma & Fechteler Co., 3 W. 13th St., New York, deal in such paper.

WASHINGTON, D. C., Nov. 20, 1899.  
 Editor of THE JEWELERS' CIRCULAR:  
 Can you give me the name of anyone who does carved ivory work? A customer has a finely carved umbrella handle, and one of the cupids has lost his head. She wishes its original appearance restored, so I want to know who can "put a head" on the cupid. If you can give me the information you will greatly oblige,  
 Yours very truly,  
 THOS. A. LADSON.

ANSWER:—Joseph Shardlow, 116 Fulton St., New York, can do this work.

NEW YORK, Nov. 21, 1899.  
 Editor of THE JEWELERS' CIRCULAR:  
 Kindly advise us where Messrs. Young & Stern (chain house) are located, and oblige,  
 Yours truly,  
 GREEN BROS.  
 ANSWER:—Young & Stern, manufacturers of chains, North Attleboro, Mass., were succeeded by Louis Stern & Co., 144 Pine St., Providence, R. I., and 37-39 Maiden Lane, New York.

SAVANNAH, Ga., Nov. 27, 1899.  
 Editor of THE JEWELERS' CIRCULAR:  
 I am desirous of getting a book descriptive of precious stones—if possible with colored illustrations—and am referred to you for information, which, if you can give, will be appreciated.  
 Very respectfully,  
 B. J. FISHER.

ANSWER:—We recommend "Precious Stones and Gems," by Edw. W. Streeter, London, England, new edition (Sixth), 345 pages, price \$6, for sale by The Jewelers' Circular Publishing Co.

OTTAWA, Can., Dec. 6, 1899.  
 Editor of THE JEWELERS' CIRCULAR:  
 Can you give me any address of one who is likely to repair shell goods like lorgnettes, combs and such like, made of real tortoise shell? and oblige,  
 Respectfully,  
 A. ROSENTHAL.  
 ANSWER:—The Potter Shell Works, Providence, R. I., will repair such articles.

**N. Y. Standard Watch Co. Sold.**

**Interests that Control the Keystone Watch Case Co. and T. Zurbrugg Co. Buy the Watch Company.**

A despatch to a Newark paper from Jersey City, Monday, stated that the stock in the New York Standard Watch Co., held by President Roberts and Howard Slater, has been bought by a person who is said to be the agent of the Drexel-Morgan Co. Who the real purchasers are was not known, but it was generally believed that some sort of a consolidation of interests is going on and that one management now controls the works in the Lafayette section of Jersey City, where the movements are made, and also the watch case factory near Philadelphia. It is said that the purchasers paid \$752,000 for the plant, or \$147 per share. About a decade ago shares could be bought for \$37. It was said that the watch case plant will be transferred to Jersey City and that the capacity of the plant will be doubled.

President Wm. C. Roberts, of the New York Standard Watch Co., was seen yesterday afternoon by a CIRCULAR reporter in reference to the above dispatch, and practically confirmed it except as to details. "You may say," he said, "that the same financial interests which now control the Keystone Watch Case Co. and T. Zurbrugg Co. will hereafter control the New York Standard Watch Co. The latter's factory will remain at Jersey City and there will be no change in the name. In fact," concluded Mr. Roberts, "the only change is that I will no longer be connected with the company."

**The Wages of the Employees of the American Waltham Watch Co.**

BOSTON, Mass., Dec. 9.—The announcement to the effect that the Elgin National Watch Co. will put into effect on Jan. 1, 1900, a readjustment of the wages of the employees, so that the general average of pay shall be restored to the figures that ruled in 1892, has called out a report to the effect that the American Waltham Watch Co. would also at an early date take similar action. One of the officials of the company, in reply to queries by a reporter, said:

"The American Waltham Watch Co. began to raise wages in January, 1897, and the Elgin Co. has merely followed its example. No further changes are contemplated at Waltham. The Waltham pay roll is already substantially on the 1892 level. Our total pay roll, including all salaries, for the month of November, 1892, was \$148,061, being an average of \$50.12 per month, or \$2 per day for 2,954 employees. For the same month in 1899 the total pay roll was \$122,182, being a monthly average of \$49.71, or \$1.99 per day for 2,458 employees. Our force of employes has been somewhat reduced since 1892, as will be seen, chiefly through the introduction of new machinery, but we produced, none the less, last month, an average of over 2,100 watches daily, and expect to raise the average this month to about 2,300."

J. A. Buck has bought out W. M. Randle, Hickman, Ky.

**WIRE US**

THE WESTERN UNION TELEGRAPH COMPANY.  
 INCORPORATED  
 21,000 OFFICES IN AMERICA. CABLE SERVICE TO ALL THE WORLD.  
 THOS. T. ECKERT, President and General Manager.  
 No. 168  
 To: *Cross & Beguelin*  
 17 Maiden Lane, New York  
 Dec 12 1899  
 Send assortment three stone rings  
 fancy stone centre one to  
 three hundred dollars also brooches  
 fifty to one hundred dollars  
 B. Quick & Co.

We are prepared for just such orders as this, and fill them soon as received.

If you have special calls for anything

you haven't got in just what you want, and you'll get it by return express! Our very complete stock of Mounted Goods is at your service.

**CROSS & BEGUELIN**

Importers and Cutters of Diamonds and Precious Stones

43 Rue de Mestay, PARIS

Telephone, 2158 Cortlandt

17 Maiden Lane, NEW YORK

**New York Notes.**

Joseph Fahys has entered a judgment for \$82.70 against John T. Baber.

Bernard Schuette, Chicago, has applied for membership in the Jewelers' Association and Board of Trade.

The Ansonia Clock Co. have entered a judgment for \$5,472.01 against Frank R. Johnson. The judgment is a revival of a former judgment for \$2,862, entered in November, 1884.

The case of Edward D. Norton, charged with stealing a gold watch from Warren Scarborough, jeweler, Long Island City, was ordered to trial by Judge Moore in the County Court of that place last week.

Ed. Cane and S. A. Lehman, the auctioneers who were recently restrained from using the names of Rogers & Bro. and Simpson, Hall, Miller & Co. in connection with their sales, have had their time extended until to-day in which to answer the suit in the United States Circuit Court, brought by the International Silver Co., and on which this injunction was issued.

Eaton & Glover, the makers of the Eaton-Engle engraving machine, have received notice that at the Greater America Exposition, Omaha, Neb., which was held from July 1 until Nov. 1, of this year, they were awarded the highest prize for engraving machines, consisting of a gold medal and diploma. At the National Export Exposition, at Philadelphia, this firm have been awarded the highest prize, a silver medal and diploma, the awarding of the prizes at this place being conducted by the Franklin Institute of Philadelphia.

Applications for tickets for the forthcoming banquet of the Jewelers' Association and Board of Trade are coming in from the members at a rate that seems to already ensure its success from the point of numbers. The banquet, as already told in these columns, will be held at the Hotel Waldorf-Astoria, Tuesday, Jan. 23, 1900, and the price of the tickets has been fixed at \$12 per plate. Though the notices of the banquet and blanks for tickets were sent out by the committee only late last week, nearly 100 tickets had been spoken for up to the time THE CIRCULAR went to press. Whether round or long tables will be used is a point the banquet committee may decide this week.

A sale of seized merchandise will, by order of Collector Bidwell, take place tomorrow at 10 o'clock A. M., at the seizure room of the Appraiser's Stores, 641 Washington St. Chas. A. Berrian, auctioneer, will conduct the sale. Among the articles

to be sold is a quantity of jewelry of all kinds, valued in the aggregate at over \$2,000. Among the principal lots of these goods are a pair of diamond earrings, valued at \$240; diamond brooch, \$224; diamond ring, \$80; gold watch and diamond pin, \$89; 95 finger rings, \$176; 104 charms, \$128; 114 pairs earrings, \$140; one case of jewelry, \$451. The last named contains 473 brooches, 254 bracelets and 1040 coral necklaces. Other pieces range in value from \$2 to \$70.

Frank Bernard, a well known crook, who, as told in THE CIRCULAR of Nov. 29, was arrested while attempting to steal from Averbeck & Averbeck's offices, 19 Maiden Lane, jewelry worth \$52, pleaded guilty before Judge Cowing, in the Court of General Sessions, Thursday, and was sentenced to three years in the State Prison. Bernard, as already told in THE CIRCULAR, pretended to be a salesman when he visited Averbeck & Averbeck's offices, and while inspecting various lines attempted to steal three scarf pins and two brooches. He was detected and put under arrest by Detectives Nugent and Madden, who had followed him to these offices. Bernard has a long record as a professional criminal, and has been arrested many times. He was arrested at Boston, Mass., in 1883 under the name of Rudolph Miller and sentenced to 18 months in the House of Correction. He was sentenced in April, 1885, in New York under the name of Rudolph Lewis, to two years in Sing Sing by Judge Cowing. Again, in March, 1896, he was sentenced

under the same name to one year in the penitentiary by Judge Newberger, and in May of last year received a similar sentence from Judge McMahon. The charge in all these cases was larceny.

The old jewelry factory in the rear of 17



**The Fountain of Specialty Satisfaction.**

You have no specialty that commands a more ready sale—that gives more satisfaction to buyer and seller—than

**Waterman's Ideal Fountain Pen.**

But to reap your advantage to the full, carry a full stock of our ornamental styles.

**L. E. Waterman Co.,**  
155-157 Broadway, New York.

Largest Manufacturers of Fountain Pens in the World.

While we cannot take any more orders to be made up before January 1st, we have a large and varied stock of CUT GLASS in New York for prompt shipment.

**C. Dorflinger & Sons,**

36 MURRAY STREET, NEW YORK.

1851. 1899.

**THE CHATHAM NATIONAL BANK, NEW YORK.**

CAPITAL STOCK,	-	-	-	\$450,000
UNDIVIDED PROFITS,	-	-	-	974,518

GEO. M. HARD, *President.*

H. P. DOREMUS, *Cashier.* W. H. STRAWN, *Ass't Cashier.*

John St. was the scene Monday of a fire which broke out on the top floor shortly before 6 o'clock p. m. The blaze started in the factory of W. P. Williamson & Co., makers of umbrella and cane heads, and completely gutted the shop before it was extinguished. The employes had left some time before and there was no one in the place when the fire started. The engines quickly responded to the alarm, and the firemen succeeded in putting out the blaze before it had penetrated beyond this floor. All the other floors below, however, were so thoroughly soaked by water that business throughout the entire building was stopped yesterday when THE CIRCULAR went to press. The amount of the loss of Williamson & Co. could not be ascertained, but it is stated to be almost total. Among the other tenants who suffered by water were: M. T. Goldsmith, manufacturer of mountings for leather goods; Brinker & Fried, polishers; F. Jeandheur, Jr., plater; Henry Goll & Co., watch case repairers; J. A. Garvin, plater; J. F. Newman, W. W. Hurd, Abegg & Herring, manufacturers of fountain pens; J. Fried, polisher; Geo. P. Gaygoul, manufacturer of fountain pens; Wollstein & Sulzberger, smelters, and L. S. Beals, die sinker.

#### Legal Proceedings Follow the Disappearance of Meyer Goldstien.

The disappearance a short time ago of Meyer Goldstien, the former bookkeeper of H. S. Kramer, dealer in jewelers' supplies and jewelry, 82 Nassau St., New York, has already resulted in legal proceedings. These proceedings include a criminal prosecution against Goldstien by Kramer for forgery and larceny, and suits against Mr. Kramer by alleged creditors of the firm. Mr. Kramer claims that Goldstien not only stole checks, money and articles of jewelry while in his employ, but also purchased goods from dealers in his (Kramer's) name, part of which he is said to have pawned. Among the jewelers who sold goods to Goldstien, believing they were selling to Mr. Kramer, are H. B. Davis & Co., Chester Billings & Son, Oppenheimer Bros. & Veith and Eichberg & Co. Mr. Kramer has repudiated these sales.

Abraham Levy, counsel for Goldstien, claims that the latter is ill at the present time, but will be produced to answer any charges that Mr. Kramer may bring against him as soon as he is well. Mr. Levy claims that Mr. Goldstien was a partner of Mr. Kramer and that his acts were within the legitimate scope of the partnership. The lawyer claims that the purchases complained of were made for the partnership and the proceeds used to settle Mr. Kramer's debts. B. H. Davis & Co. are among the creditors who will test the question of partnership of Goldstien

and Kramer by bringing action against the latter.

#### Death of William H. Ball.

William H. Ball, one of the leading manufacturers in the jewelry trade of Newark and New York and head of one of the oldest manufacturing firms in the business, died at his home in Newark yesterday at 8 o'clock a. m., after a brief illness. Death was due to intestinal trouble, from which he had been suffering for some time. Mr. Ball was taken ill in October last, and after three weeks apparently recovered. He, however, suffered a relapse on Dec. 5 and was confined to his bed from that time till his death.

There was probably no more widely known or better liked member of the trade in the vicinity of Maiden Lane than William H. Ball, whose face and name



THE LATE WILLIAM H. BALL.

were alike familiar to all down-town jewelers. The deceased was head of the manufacturing jewelry firm of William H. Ball & Co., 14-16 John St., New York, with factory in Newark, N. J. The business was founded in 1842 by Taylor & Ball, to which firm Mr. Ball was a direct successor. Taylor & Ball were succeeded by Horace W. Ball & Co., whose senior member was an uncle of the deceased, and whose other members were Hooper C. Ball, father of the deceased, and a Mr. Scudder. During subsequent years the business was known as Ball, Barnard & Parsell, Ball, Barnard & Rogers, then Ball & Barnard and finally William H. Ball & Co.

The deceased was born in Newark in 1841, and was the son of Hooper C. Ball.

Mr. Ball's childhood was passed in his native city, where he received his education, and when he reached his 18th year he entered his father's business in the capacity of a utility boy in the office in New York. Later he went to the factory to learn the trade of jeweler, and after mastering it became salesman for the firm. In 1861 Hooper C. Ball died, and then William H. conducted it for the widow until 1865, when he purchased her interest. Then, with Thos. Barnard, he formed the firm of William H. Ball & Co., and continued under the same style after Mr. Barnard's death in 1886.

During his travels on the road Mr. Ball visited many parts of the country, including all the eastern cities and part of the south and west, and in this way personally became acquainted with a great number of the customers of his firm. By reason of his thorough knowledge of the jewelry trade and his natural energy and ability Mr. Ball built up his business until to-day the firm are recognized as one of the largest manufacturers of gold bracelets in this country. The deceased was married in 1865, and two daughters, both married, survive him. He was a member of St. John's Lodge, F. & A. M., of Newark, and in the jewelry organizations was prominent as a member of the Jewelers' League, Jewelers' Association and Board of Trade and Jewelers' Security Alliance. The funeral services will probably be held on Friday.

#### Death of H. L. Judd.

WALLINGFORD, Conn., Dec. 11.—Hubert L. Judd died this afternoon after a long illness. He was born in New Britain 70 years ago, and first engaged in business there. Later he became the head of the brass manufacturing concern, H. L. Judd & Co., then of Brooklyn, N. Y., and later of this place. He leaves two children, a son and a daughter.

#### Lancaster, Pa.

John W. Ellers, New York, was the guest on Sunday of Mr. Drury, of the Non-Retailing Co.

D. F. Dubbs, Hanover, Pa., was a business caller at the L. C. Reisner & Co. establishment last week. Mr. Dubbs reports excellent business in his section.

Owing to the continued illness of Fred Wheeler, L. C. Reisner & Co. have taken J. Ed. Reisner from the western territory to care for the eastern field, in which the firm have a large trade.

The local jewelers who have been open evenings since Dec. 1 report a larger watch trade this season than ever before. All have taken on extra help over the holidays, and signs bearing "Presents reserved for small weekly payments" are prominently displayed.

## The Mercantile National Bank

OF THE CITY OF NEW YORK,

BROADWAY AND DEY STREET,

Solicits Accounts from the Jewelry Trade.



**Philadelphia.****TRADE CONDITIONS.**

Local jewelers are enthusiastic over the early beginning of the holiday trade. Representative firms reported to THE CIRCULAR correspondent that business has been better than for years past.

James W. Barry is now with James D. Hughes, wholesale jeweler.

John Sackett, son of Wm. P. Sackett, is now with Peter L. Krider Co.

Leo Hughes is now associated with his brother, James D. Hughes, wholesale jeweler.

Jake Zimmern, southern representative of M. Sickles & Sons, has returned from a three months' trip.

Charles Lockhart has left the employ of James D. Hughes, and is now with H. O. Hurlburt & Sons.

Louis Scherr, son of George W. Scherr, has accepted a position with Gimbel Brothers as an engraver.

E. M. Bracher & Co., jobbers, New York, have established a branch office in this city at 730 Chestnut St.

Harry Schimpf, of H. Muhr's Sons, is dangerously ill and has been confined to his home for the last two weeks.

A quantity of silver ware and cutlery was stolen from the store of Daniel Weiss, Easton, Pa., last Thursday night.

Robert Wright, formerly of Harris & Shafer, Washington, D. C., is now employed in Wanamaker's jewelry department.

J. Albert Caldwell, of J. E. Caldwell & Co., was last Monday re-elected a member of the board of directors of the Union League.

A valuable collection of diamonds and jewelry from the estate of Mrs. B. Stephen, a wealthy Philadelphian, is to be sold late this week at auction.

H. Muhr's Sons have pledged themselves to give \$100 towards the fund to secure the holding of the Republican National Convention in this city next June.

Merchant & Co. issued on Saturday a foreign attachment from the Common Pleas Court against the Philadelphia Jewelry Mfg. Co., with bail fixed at \$1,421.36.

L. C. Reisner & Co.'s branch office will be removed to the new building at 8th and Bennett Sts., after the first of the year, and other local jewelers contemplate taking offices at the same place.

Charles Stutzbach, an aged employe of the T. Zurbrugg Co.'s watch case factory, Riverside, N. J., was struck and killed by a train of the Amboy division of the Pennsylvania Railroad at Riverside last Saturday.

Harry O. Hines, Gettysburg, Pa., came into possession last Tuesday of a rare piece of pottery. It is an Aztec heart dish, probably 700 years old, and was found by an American laborer digging a ditch in the City of Mexico.

Owing to the holiday rush the day of meeting of the Jewelers' Club has been temporarily changed from Tuesday evening to Sunday. John R. Morss, of R. Blackinton & Co., New York, has been proposed for membership in the Jewelers' Club.

Antone Belati, manufacturer of optical goods, of this city, was arrested Friday night, charged by his sister-in-law, Martha J. Malloy, with felonious assault in the woods near Lincoln Park, Aug. 9. Belati

waived a hearing and was committed by Justice Pancoast in default of \$1,000 bail.

John F. Simons, of Simons, Bro. & Co., has been named as chairman of the committee of the Manufacturers' Club to solicit funds from the trade in the interests of the city to secure the Republican National Convention in 1900. John Gordon Gray, of Queen & Co., Inc., will look after the opticians.

A. L. Millard has brought suit against Henry Weinmann, jeweler, to recover \$20,000 damages for malicious prosecution. Millard was arrested in 1896 on a warrant sworn out by Weinmann, charging him with the larceny of a gold bracelet valued at \$100. The case was tried in the Quarter Sessions Court and Millard was acquitted.

Among the buyers who visited the local wholesalers last week were: B. C. Foster, Bristol, Pa.; Jesse Webb, West Chester; J. S. Baker, Glen Rock; Milton Reed, Doylestown; C. S. Hunsberger, Souderton; B. F. Schlichter, Limerick; J. B. Heckler, Mainland; John C. Sheldon; Bridgeton, N. J.; E. L. Thomas, Phoenixville; M. F. Bovard, Manayunk, and Charles Kohler, Norristown.

The action of Partridge & Richardson, who were burned out in the great fire two weeks ago, in moving into the store at 8th and Chestnut Sts., formerly occupied by Sharpless Brothers, has been a source of greatest relief to the Chestnut St. retail jewelers, who have been somewhat alarmed for months past at a rumor that the corner was to be turned into a big retail jewelry department.

During an address, delivered at the Manufacturers' Club last week by H. Rotheram, delegate from the Melbourne, Australia, Chamber of Commerce, to the recent International Commercial Congress, on "Australia as a field for American manufacturers," Mr. Rotheram urged American manufacturers to secure local agents as the best means of introducing their goods, and among a list of the greatest needs of the country mentioned watches, clocks and silver ware.

John Smith, a negro burglar supposed to have robbed a number of jewelry stores in Chester, was arrested last week. He was identified by Jacob Rosenberg as the man he had seen jumping from a window in his store. Three gold and four silver watches were found in his possession. Smith was convicted in court in Media Dec. 8 on the charge of burglary and sentenced to eight years in the Eastern Penitentiary. Smith robbed the jewelry store of Samuel Sapovits of 16 watches, and also the clothing store of Jacob Rosenberg.

The will of William F. Kercher, formerly in business at 3d and Arch Sts., who died recently at his home, 3125 Mantua Ave., worth \$38,000, was admitted to probate Friday. He devises his entire stock of watches, diamonds, jewelry, store fixtures and everything in connection with his business to his son, Wm. E. Kercher, who is constituted one of the executors and the largest beneficiary. Mr. Kercher will carry on his father's business. He was also bequeathed all the book accounts of money due his father for goods sold and delivered and remaining unpaid at the time of his death.

**Newark.**

George Grinsey, diamond setter, of Nutley, who left behind him in a trolley car a satchel containing 60 gold rings, 300 unset rubies and some diamonds, hasn't found the goods yet.

Mrs. Lena Hanna, 19 years of age, was arraigned in Judge Lambert's court Wednesday charged by Ernest A. Young, jeweler, 53 Market St., with the theft of two diamond rings valued at \$50. According to Mr. Young, Mrs. Hanna entered his place and asked for rings. The jeweler says she handled her muff in a peculiar way. None of the rings in the tray seemed to suit and she started for the door. Young says he saw that two rings were missing. He accused Mrs. Hanna. The woman denied the theft, but Young claims he heard something drop to the floor, and soon found the two rings near where the woman had stood. Mrs. Hanna denied that she stole the rings, but was held in \$300 bail for the Grand Jury.

John J. Jackson, proprietor of a jewelry shop at 91 Mechanic St., became involved in a quarrel with another tenant in the building Dec. 8, and after a scuffle he fell upon the floor and died. Jackson's store occupies the basement and ground floor, and Christian Fleissner has a leather manufacturing establishment on the first floor above. Smoke from a fire in the jewelry shop ascended to the upper floors, and Fleissner went down to Jackson to protest. Jackson went up stairs to see Fleissner about the matter. When Jackson sank to the floor he was helped to his office and two doctors were summoned, but could do nothing for him. They said death had been caused by fatty degeneration of the heart. Jackson was 55 years old and weighed more than 300 pounds.

A. F. Lynch, jeweler, Tomah, Wis., was acquitted at Mauston, Wis., a few days ago of the charge of murdering his father-in-law, William Welzel.



# A. & B.

## HEADQUARTERS

FOR

## Waltham Watches

EVERY GRADE.

## AVERY & BROWN,

68 Nassau St., New York.

## Providence.

### RETAIL TRADE CONDITIONS.

Unusually attractive displays for the holiday trade are being made by the retail jewelers in this city, and the jewelers unanimously report business to be better this season than it has been for years. For a long time, whether because Providence is a manufacturing center in the jewelry trade or for other reasons, the retail jewelry business here has been comparatively small in view of the size of the city. This Christmas season there is a noticeable difference. The jewelers are making brilliant window displays, and by advertising in the daily papers and in other ways are making a strong bid for trade, of which there can be no doubt they are receiving a large share.

The Grant Co. is the name of a new manufacturing jewelry firm at 193 Richmond St.

George H. Randall has severed his connection as salesman for P. S. Eddy, 144 Pine St.

Thomas J. Halliday has withdrawn from his connection with the Torrey Jewelry Co., Attleboro, and is now with J. W. Grant & Co., 25 Calender St., this city.

The new brick addition to the factory of W. H. Luther & Son, on Oxford St., has been completed and is rapidly being occupied by the firm, whose capacity is nearly doubled thereby.

W. C. Gardner has gone into business as a repairer at 76 Westminster St., the old stand of J. G. Robinson, whose death was recorded in THE CIRCULAR of Nov. 22.

Philip Stern, this city, and Julius Stern, New York, have associated themselves with Henry Ludwig, of the H. Ludwig Co., for the manufacture of jewelry at the shop until now occupied by the latter concern.

According to news received from Washington, D. C., a robbery was committed on board the steam yacht *Senator* last Thursday, \$1,900 in money and a diamond stud worth \$350 being stolen. The yacht is the property of Charles H. Fuller, of Geo. H. Fuller & Son Co., Pawtucket.

Among a number of jewelry buyers in town the past week, replenishing their stocks, were: A. L. Stone, Stone Bros., Chicago; W. Williams, for Robert Johns, Chicago; A. W. Neisser, Neisser Jewelry Co., Milwaukee; B. C. Silver, J. & B. C. Silver, Montreal; A. Kunstader, J. Floersheim, Kunstader & Co., Chicago; and J. A. Main, Warsaw, N. Y.

Besides working their entire large force in their factory on the sixth floor of the Manufacturers' building 13 hours a day for many weeks, W. & S. Blackinton have been obliged to hire additional floor space to keep up with the volume of business. The new portion is enough in itself to make a good sized factory, occupying an entire floor in the L under the shop of Parks Bros. & Rogers. This is devoted to the fine chain department, from 60 to 70 women being employed on this work.

Babcock & McLoughlin, whose shop was visited by fire twice in the last few weeks, once at 180 Friendship St. and again after their removal to 409 Pine St., have dissolved partnership, A. L. McLoughlin withdrawing from the firm. Their business will be continued at 409 Pine St. by their successors under the style of A. W. Babcock & Co., the members of the new firm being A. W. Babcock, R. R. Babcock and W. D. Stone.

Mr. Stone was formerly with the Fisher Co. and more recently with W. A. Lakey & Co.

The Dunbar-Leach-Garner Co. have been formed by articles of incorporation filed at the office of the Secretary of State, in this city, Thursday, the incorporators being Edwin F. Leach, Clarence M. Dunbar and William H. Garner. The articles state that the company formed for the purpose of manufacturing and dealing in plated and other stock for jewelers, jewelers' findings and plated and other jewelry and other business incidental thereto or connected therewith. The capital is \$12,000 and the location of the new company is Providence.

Sidney O. Bigney, of S. O. Bigney & Co., informs THE CIRCULAR correspondent that he is beginning to make arrangements for the removal of his factory now in the Manufacturers' building, 7 Beverly St., to his new factory at Attleboro. He expects to begin to move on Dec. 20 and to "pull out" from his present quarters entirely, if possible, on the 27th. The details of the building of his immense new factory at Attleboro have already been given in THE CIRCULAR. The shop reserved for his own use in the new building has a floor space measuring about 275 by 40 feet, which will provide room enough for the employment of between 300 and 400 hands.

### The Attleboros.

Clarence W. Richards is reported as the new salesman for W. H. Bell & Co.

A buyer for J. Floersheim, Kunstader & Co., Chicago, called on the local manufacturers last week.

A change for the better is reported in the condition of Oscar M. Draper, who has been quite ill recently.

Miss Edythe D'Aubigne, daughter of J. Albert Bigney, of Regnell, Bigney & Co., died last week, aged 3 years.

Clarence A. Fisher, of C. A. Fisher & Co., who has been visiting relatives in Milford, N. H., returned to his office last week.

Harry C. Perkins, North Attleboro, left last week for Chicago, where he will be associated with his father in the diamond cutting business.

R. Curtis Read has resigned his post as traveler for J. C. Cummings & Co. Fred W. Brigham has been made salesman for Cheever, Tweedy & Co.

A change has been made in the hours of work in the group of factories at Robinsonville. The operatives work with a 40-minute noon intermission in order to get away to their homes on more convenient cars and trains.

The local papers are giving considerable space to wondering what will be done with S. O. Bigney & Co.'s force of 200 hands when the firm start work in Attleboro on the 27th. There is not nearly accommodation for the operatives now in town, and North Attleboro, Chartley, Norton, Taunton, Pawtucket and Mansfield hold already a large overflow population.

The Attleboro Woman's Suffrage League has made public its gratitude to a score of jewelry houses who through it made exhibit of their products at the re-

cent bazar held in Boston under the auspices of the State organization of the league. The firms that thus advertised the town with their goods were D. A. White & Co., J. T. Inman & Co., Marble, Smith & Forrester, the Torrey Jewelry Co., the D. F. Briggs Co., McRae & Keeler, Simms & Co., F. W. Weaver & Co., Charles M. Robbins, David E. Makepeace, Attleboro Mig. Co., A. Bushee & Co., Regnell, Bigney & Co., Bliss Bros., Horton, Angell Co., Smith & Crosby, C. H. Allen & Co., and the James E. Blake Co., R. F. Simmons & Co.

Fred E. Bodman, who is leaving his post as foreman for R. F. Simmons & Co., to enter business as a proprietor in Providence, was presented with a very handsome roll top desk by the employes Friday. Mr. Bodman, Edward E. Richardson, head of the selling department, and Fred H. Carpenter, the western salesman, are all leaving to be partners in a new manufacturing house in the Rhode Island capital. This necessitates a variety of changes at the office. Mr. Bodman is succeeded by August L. Blumenthal, who has been assistant foreman for 10 years. Mr. Richardson is succeeded by Harold E. Sweet, formerly eastern salesman. Mr. Carpenter is succeeded by Louis E. Fay, for years western man for Dutee Wilcox & Co., Providence. The vacant eastern route will be covered by George L. Sweet, who leaves Chapman & Barden, Plainville, for that purpose. J. Lyman Sweet, head of the firm, who has been exiled from his New England home since 1896 with a persistent illness, has now returned and taken general management of the whole house. His return to the circles of business was a welcome one, as he has always been one of Attleboro's most public spirited citizens.

### Boston.

Frederick H. Pope, of D. C. Percival & Co., went to New York the past week on a business trip.

R. G. Kittredge, jeweler in the city of Waltham, has been elected a member of the Board of Aldermen of that municipality.

The New England Association of Opticians have just received as a gift from Sussfeld, Lorsch & Co. a fine large Bardo astronomical telescope.

Arthur W. Forbes, formerly with D. C. Percival & Co., has made arrangements to go to Matanzas, Cuba, where he intends to engage in business on his own account.

Walter B. Snow, resident representative of the Poole Silver Co., Taunton, underwent a surgical operation at the Massachusetts General Hospital last week, and is now convalescent.

The many friends of Charles Harwood, of Harwood Bros., have been gratified to hear encouraging reports of his progress toward recovery from the serious attack of pneumonia which has kept him confined to his home for several weeks.

W. S. Tiffany, who recently resigned the presidency of the Tiffany Jewelry Co., has disposed of his interest in the business to the company and severed his connection therewith. He will be located in Providence hereafter, having made new business connections in another line of trade in that city.

## Special Notices.

Rates 75c. per insertion for notices not exceeding 3 lines (25 words); additional words 2 cents each. If answers are to be forwarded, postage stamps must be enclosed. Two insertions, 15 per cent off; three insertions, 20 per cent off; four insertions or more, 25 per cent off. Payable strictly in advance.

Display cards on this page will be charged at \$2.00 per inch for first insertion, subject to same discount as above for subsequent insertions.

Under the heading of SITUATIONS WANTED on this page advertisements will be inserted for One Cent a Word, each insertion, no discount, but no advertisement will be inserted for less than 25 cents. This offer refers to SITUATIONS WANTED ONLY. Payable strictly in advance.

In all cases if answers are to be forwarded, 10 cents extra to cover postage must be enclosed.

## Situations Wanted.

**JEWELRY SALESMAN** now employed desires to change; highest reference. Address "Cluster" care Jewelers' Circular.

**SALESMAN**, hustler, established trade for N. Y., Pa. and N. E., wants a manufacturer's line, 10k, or 14k. goods, Jan. 1; salary only. Address A. L. P., care Jewelers' Circular.

**PRACTICAL DESIGNER**, with 15 years' experience in all branches of sterling silver ware, desires position; All references furnished. Address "Sterling," care Jewelers' Circular.

**SUPERINTENDENT AND DESIGNER** with large experience in all branches of sterling silver ware desires position; best of references. Address "Designer," care Jewelers' Circular.

**EXPERIENCED TRAVELER** desires position from Jan. 1; well acquainted with the retail trade east and west; understands diamonds, colored goods, loose or mounted; watches, jewelry or silver ware; best of references. Address A. J., care Jewelers' Circular.

**WANTED**—Side line of jobber's or manufacturer's line of jewelry and novelties, on commission or salary; command trade in New York, Pennsylvania, Connecticut and Massachusetts; 20 years' experience. Address "Salesman," care Jewelers' Circular.

**AN OPTICIAN**, watchmaker and engraver wants a steady position with a good firm; understands the business thoroughly; young man, single, sober and steady; have tools and trial case; state salary in first letter; All references. Address "Optician," care Jewelers' Circular.

## Help Wanted.

**WANTED**—Salesman for city and vicinity. American Watch Case Co., 9-11-13 Maiden Lane, New York.

**WANTED AT ONCE**—First-class watchmaker, jeweler, optician and engraver; must be sober and reliable; none other need apply; \$15 per week. Address S. V. Fasnach, Raleigh, N. C.

**WANTED**—Two first-class manufacturing jewelers and stone setters; one first-class engraver and jeweler; references required. Geo. Wettstein, manufacturing jeweler, Cedar Rapids, Iowa.

**STERN BROS.**, West 23d St., New York, require a thoroughly competent buyer for their jewelry department. Apply by letter only, stating length of experience and where previously employed.

**WANTED**—An experienced salesman on salary and commission; one acquainted with the Newark manufacturers and large New York dealers; best of references required. Address H., care Jewelers' Circular.

**WANTED**—Traveling salesman on commission to sell a small but well assorted stock of colored and precious stones; one representing a diamond or mounting house preferred; mention territory and references. Address "Importers," care Jewelers' Circular.

**AFTER JAN. 1**—A first-class manufacturing jeweler and stone setter who can make all kinds of diamond mountings, cluster work, and understands enameling and the use of dynamos for gilding and plating, as foreman in a newly equipped shop with six to eight men; highest salary and permanent position to right man; best of references required. Address G. O., care Jewelers' Circular.

## INDEX TO ADVERTISEMENTS.

Aikin, Lambert & Co.....	41	Knowles, Dr.....	47
Aikin, Lambert Jewelry Co.....	41	Knowles, J. B. & S. M., Co.....	7
Alford, C. G., & Co.....	23	Kohn & Co.....	11
American Watch Case Co.....	47	Kohn, Alois, & Co.....	9
American Waltham Watch Co.....	17	Lady Racine.....	46
Arnstein Bros. & Co.....	48	Lederer, S. & B., Co.....	48
Austin, John, & Son.....	48	Ledos Mfg. Co.....	44
Avery & Brown.....	29	Levy, L. W., & Co.....	48
Ball, Wm. H., & Co.....	38	Lind, Thomas W.....	4
Bassett Jewelry Co.....	5	Lintz, Jules J.....	43
Bell Watch Case Co.....	22	Malliet, C. G., & Co.....	8
Billings, Chester, & Son.....	9	Mathews & Prior.....	11
Bowden, J. B., & Co.....	8	Mathey Bros., Mathez & Co.....	46
Bradley Polytechnic Institute.....	48	Mausier Mfg. Co.....	22
Bradley & Hubbard Co.....	44	Mercantile National Bank.....	28
Chatham National Bank.....	27	Mossberg & Granville Mfg. Co.....	22
Clark & Coombs.....	40	Mount & Woodhull.....	8
Conley & Straight.....	48	Myers, S. F., Co.....	21
Cook, Edward N.....	47	New England Watch Co.....	16
Cornell & Andrews.....	38	Noble, F. H., & Co.....	35
Cross & Beguelin.....	26	Omega Watches.....	4
Crossman, Charles S., & Co.....	13	Oppenheimer Bros. & Veith.....	9
Crouch & Fitzgerald.....	47	Pairpoint Mfg. Co.....	44
Crown and Lion Watch Cases.....	43	Potter, Wm. K.....	13
Day, Clark & Co.....	48	Providence Stock Co.....	43
Deitsch Bros.....	47	Reichhelm, E. P., & Co.....	43
Didisheim, Hipp., & Bro.....	16	Reisner, L. C., & Co.....	3
Dorflinger, C., & Sons.....	27	Rich, H. M., & Co.....	44
Dubois Watch Case Co.....	47	Robert, E. E.....	19
Dueber-Hampden Co.....	15	Roy Watch Case Co.....	37
Eaton & Glover.....	40	Rumpp, C. F., & Sons.....	46
Eisenmann Bros.....	10	Saunders, John F.....	9
Eliassof Bros. & Co.....	38	Schulz & Rudolph.....	8
Esser & Barry.....	40	Sherwood, John W., & Co.....	14
Fahys, Jos., & Co.....	33	Simmons, R. F., & Co.....	38
Fairchild & Johnson Co.....	48	Simmons & Payne.....	44
Field & Beattie.....	44	Simons, Bro., & Co.....	44
Foster, Theodore W., & Bro. Co.....	2	Smith, Alfred H., & Co.....	10
Frankel's Sons, Jos.....	13	Stern Bros. & Co.....	38
Freund, Henry, & Bro.....	19	Sternau, S., & Co.....	19
Friedlander, R., L. & M.....	48	Strasburger, Byron L., & Co.....	10
Fuchs, Ferd., & Bros.....	44	Street, Geo. O., & Sons.....	18
Goodfriend Bros.....	9	Towle Mfg. Co.....	35
Goodnow & Jenks.....	2	Treibs Bros.....	13
Gorham Mfg. Co.....	24	Trenton Watch Co.....	18
Harris & Harrington.....	48	Wallace, R., & Sons Mfg. Co.....	6
Hayden Mfg. Co.....	20	Waterman, L. E., Co.....	27
Hedges, Wm. S., & Co.....	8	Westphal, W. C. A.....	47
Hemberger & Lind.....	47	Wheeler, Hayden W., & Co.....	12
Hraba, Louis W.....	44	Whiting, F. M., & Co.....	21
Jacot & Son.....	47	Wood, Chas. F., & Co.....	48
Juergensen, Jules.....	8	Wood & Hughes.....	44
Kahn, L. & M., & Co.....	48	Woods & Chatellier.....	11

## Business Opportunities.

**I BUY JEWELRY STOCKS.**—Retailers or wholesalers wishing to dispose of surplus or entire stock of diamonds, watches and jewelry can find quick cash buyer by addressing John Grosberg, 104 2d St., New York.

**JEWELRY STOCKS BOUGHT.**—Retailers wishing to dispose of surplus or entire stock of diamonds, watches and jewelry can find quick, cash, strictly confidential buyer by addressing S. Marx, 22 Lispenard St., New York City.

## To Let.

**FRONT OFFICE**, 18x72 (occupied by the E. Howard Watch and Clock Co. for 14 years); also smaller offices and rooms for light manufacturing; rents low. Knapp Building, 41 and 43 Maiden Lane, New York.

## For Sale.

**FOR SALE.**—Fine jeweler's burglar-proof Diebold safe. Apply or address J. C. Broghamer, care of C. W. Little, 43 Cortlandt St., New York.

## Miscellaneous.

**WHEN WANTING** a good lathe, remember the "Moseley"; there is none better, many not as good; their reputation has been built up by good design and good workmanship with very little wind; wind alone will not do it; send for our new illustrated circular. When interested, write your jobber, or Moseley Lathe Co., Elgin, Ill.

## TO RENT in Silversmiths' Building, CHICAGO.

A fine office on Wabash Avenue front, with north and east light, 20 x 42 feet, adjoining the Gorham Mfg. Co.'s salesroom on the sixth floor. Most desirable location in the city. For terms apply to

**GORHAM MFG. CO.,**

Silversmiths' Building, CHICAGO.

## SALESMAN to travel south

wanted with an up-to-date line of medium price Solid Gold Jewelry (Diamond set, &c.), extensive line of Sterling Novelties and high-grade Gold-Filled Vest Chains, Lorgnette Chains, Dumb-bell Links and Brooches. Salary, \$2,000 and expenses. Don't answer this unless you have established trade south, and can furnish high-grade references.

Address with particulars, "WIDE AWAKE,"

Care of JEWELERS' CIRCULAR.

## FOR SALE. TO CLOSE AN ESTATE. A

jewelry business in one of the brightest towns in Wisconsin. An excellent business opportunity. Capital required about \$3,500.

Address, TOWLE MFG. CO., 149 State St., Chicago.

### Decision as to Liability of Jeweler for Goods Returned by Express.

The Appellate Division of the New York Supreme Court recently handed down an interesting decision in the action of Walter C. Stearns against Oliver M. Farrand, retail jeweler, 3 Maiden Lane, New York, involving the jeweler's liability for the loss of rings sent by express. The action arose in this way: On Dec. 23, 1897, Mr. Stearns, who is an old customer of Mr. Farrand's, called at the latter's store and left some rings to be cleaned and reset. He instructed the jeweler to send them by express to his home in Fredericksburg, Va. The work was done by Mr. Farrand and the goods sent the next day by the Adams Express Co., the only express company running to Fredericksburg. The alleged value of the rings was \$268, but no value was given to the express company. The rings were not received by Mr. Stearns, and at his request Mr. Farrand sent him the express receipt. This was the last the jeweler heard of the transaction until September, 1898, when Mr. Stearns made a demand for the rings or their value, claiming that the jeweler was liable for their loss, although no charge was made for the repairing. Mr. Farrand refused to consider himself liable and Mr. Stearns brought suit in the City Court of New York.

The case came to trial early this year before Judge Schuchmann and a jury, and as there was no conflict in the testimony each side moved that the Judge direct a verdict in its favor. Judge Schuchmann denied the motion of Mr. Farrand's attorney, but granted that of Mr. Stearns's and a judgment was entered against the jeweler. From this an appeal was taken to the General Term of the City Court, which reversed the judgment of the court below. An appeal was taken by Mr. Stearns from this to the Appellate Term of the Supreme Court.

In the long opinion written by Judge Freedman the court holds that Mr. Farrand, having exactly complied with the instructions of his customer, was not liable for the loss of the jewelry caused in transit.

### Sneak Thief Operates in the Store of Robert Leding.

WASHINGTON, D. C., Dec. 7.—Robert Leding, jeweler, informed the police last night that he had lost several valuable articles from his stock by theft yesterday. During a rush in the establishment about 2 o'clock in the afternoon, a stranger sought to look at some lockets and chains which were in a tray. The attention of the clerk was distracted by another customer, and the stranger disappeared shortly afterward. When the stock on the tray was rearranged, it was discovered that a gold chain valued at \$33 and a gold locket worth \$28 had vanished. The stranger who is suspected is described as being a man about 5 feet 6 inches in height, well dressed and of very gentlemanly demeanor. He was about 40 years of age.

Wm. W. Stubbs, Marshalltown, Ia., has filed a petition in bankruptcy, giving liabilities of \$3,137.

### Last Week's New York Arrivals.

**THE CIRCULAR** has perfected arrangements for obtaining the names and hotel addresses of all the latest buyers visiting New York, and each day posts in its office, 11 John St., cor. Broadway, a bulletin which every member of the trade is cordially invited to copy.

Bath, N. Y., Chas. Kausch, St. George. Boston, Mass., E. Passmore, St. Denis. Buffalo, N. Y., J. J. Dickinson, Grand Un. Cumberland, Md., Walter Powell, Morton. Hartford, Conn., F. H. Sloan, Park Ave. New Haven, Conn., Wm. Reeves, St. Denis. Scranton, Pa., George Waters, Morton H. Seneca Falls, N. Y., A. G. Golden, Imperial.

### Trans-Atlantic Voyagers.

#### TO EUROPE.

Mr. and Mrs. E. Aug. Neresheimer, New York, sailed Wednesday on the *St. Paul*.

#### FROM EUROPE.

Carl F. Lomb, of the Bausch & Lomb Optical Co., Rochester, N. Y., accompanied by his wife, returned last week on the *Trave*.

### Middletown, Conn.

Miss Eugenia Bartlett, of Boston, Mass., has accepted a position with Clark & True.

Wesleyan University is having a set of chimes put in the tower clock by the E. Howard Watch & Clock Co.

One of the first pieces of hollow ware to be turned out by the new plated ware company of this city is a fine loving cup presented by Company H to First Sergeant T. McDonough Russell. It is pronounced by competent judges to be a very fine piece of work.

Local oculists and opticians are having a rush of business at present by reason of eyesight tests in schools. Many of the children have been found to have some defect, which has been reported to parents, and the children have been sent to oculists and opticians to determine the trouble.

### Trade Gossip.

The Mossberg & Granville Mfg. Co., Providence, R. I., have opened a western office at Room 12, Mercantile Bank building, Cleveland, O., which will be under the management of George R. Lamb, who is a thorough mechanic and well posted on jewelers' and silversmiths' machinery, and who will give prompt attention to any inquiries for this class of machinery he receives.

As a sign of the general prosperity throughout the country Henry Freund & Bro., 9-13 Maiden Lane, New York, point to the large number of special orders they have received for expensive goods not usually carried in stock by retailers. This firm have special facilities for filling such orders and expressing the goods the same day the order is received.

### News Gleanings.

M. G. Roseman has opened a jewelry store in Perry, N. Y.

Slade & Parshall are successors of F. A. Wiley, Mitchell, S. D.

E. B. Buck, jeweler, Brewer, Me., is to close out his business and leave the city.

Herman Engel, Wilkes-Barre, Pa., has moved his place of business to 25 Public Sq.

Henry Childs has succeeded to the business of the late Frank Childs, Angleton, Tex.

A. O. Albin, Sayville, N. Y., who has been in ill health for some time, will close out his business.

Gilbert D. Gunn is the new superintendent of the Worcester Optical Co., Worcester, Mass.

O. H. Farr, Wabash, Ind., recently bought out James Lynn, Jr., a brother jeweler of that town.

J. C. Nelson and J. D. Hovermale have purchased the repair business of J. A. Richards, Sharpsburg, Ky.

In a fire in Augusta, Ga., the stores of M. L. Freeman and Lewis J. Schaul are reported to have been burned out.

M. Goodman and H. Lauffer, Memphis, Tenn., recently combined their stores under the name of Goodman & Lauffer.

John Drew, a crook, who, it is claimed, stole several watches from the jewelry store of William F. Spencer, Kingston, N. Y., on Nov. 22, was arrested in Amsterdam, N. Y., Dec. 7.

Fred Getty, a former employe of the Illinois Watch Co.'s plant, Springfield, Ill., has perfected the invention of an electric clock, and is reported to be manufacturing the clocks in Chicago.

The show window in K. Radin's jewelry store, Reading, Pa., was broken into early on the morning of Dec. 7, and about \$25 worth of goods abstracted. The window was smashed with a large stone and a good sized hole made through which the various articles were taken.

The Harrisburgh (Pa.) newspapers are highly complimentary in their descriptions of the remodeled store of E. L. Rinkensbach, 1221 N. 3d St. The main store room has been extended to the rear so as to admit of the addition of an office and a workshop. Two large mahogany wall cases—one for each side of the room—18 feet long, elaborately carved and with sliding fronts of heavy plate glass, beneath which are ornate drawers with brass pulls, are conspicuous improvements. There is also a large French plate mirror on the left of the entrance, and the room has been artistically papered throughout. Electric lights illuminate the cases and every corner of the store.

## SPECIAL NOTICES

IN THE

## Jewelers' Circular

PRODUCE THE

DESIRED RESULTS.

O. T. Chapman, Cedar Vale, Kan., has given a realty mortgage for \$400.

A. E. Foster has succeeded to the jewelry business of I. B. Frazee, Blairtown, Ia.

A. Robert has removed his stock of jewelry from Spokane, Wash., to Wallace, Idaho.

A. C. Dorner, Helena, Mont., has given chattel mortgages on stock amounting to \$4,600.

H. J. Ogden has bought out the jewelry business of W. H. Todd, 31 Congress St., Portland, Me.

Louisville Ice Co., Louisville, Ky., want addresses of parties handling church or tower clocks.

J. C. Street has resumed business at his old profession as watchmaker and jeweler in Lakeland, Fla.

Andrew C. Bosen, Ephraim, Utah, has received a release from a chattel mortgage amounting to \$500.

The Court has issued an order of sale for the stock and machinery of M. A. Miles, Salt Lake City, Utah.

In a fire in Onancock, Va., a few days ago, J. W. Duncan's jewelry store was among the places destroyed.

S. H. Kantor has succeeded to the entire jewelry business of the old firm of Kantor Brothers, Fargo, N. D.

C. O. Balliett, Waterloo, Ia., is remodeling his store, and the improvements will be completed by Jan. 1.

H. & S. Nathan, jewelers and pawnbrokers, Beaumont, Tex., have given a chattel mortgage on a safe for \$220.

The stock of jewelry of Chas. Joyce, Garland, Tex., sustained a loss in the recent fire of about \$100 in removal.

Porter & Marlow, Moline, Kan., have dissolved, and C. L. Porter will succeed to the entire business and continue it in the same location.

The improved store of Mrs. A. Seidensticker, at 237 High St., Hamilton, O., arouses the admiration of the public and of the local press.

Fire last week destroyed the Rosenbaum block, Meridian, Miss., causing a property loss estimated at \$250,000. Among the losers is E. R. v. Seutter, jeweler.

Dr. R. S. Lindsay has sold his drug store in Constantia, N. Y., to H. F. Talcott, who will continue the drug business together with his jewelry store in the Masonic block.

On the night of Dec. 5 a serious fire occurred in Maysville, N. D., among the stores burned out being that of A. L. Thompson, jeweler. His loss on building is placed at \$1,500; insurance \$1,000.

Burglars entered J. J. Ring's jewelry store, Logan, Ia., a few evenings ago by breaking out the glass in the rear door while the proprietor was at supper, and stole five watches, 20 rings and several chains, altogether amounting to \$125.

Wilson Omer, who has been conducting a jewelry business in Cainesville, Mo., in connection with numerous other lines of business, has decided to move the first of January to Tabor, Ia., where he will engage in the jewelry and watchmaking business exclusively.

Willard & Frick Co., of Rochester, N. Y., were incorporated Dec. 7, with a capital of \$250,000 to manufacture time locks

and automatic time stamps and registers. Among the directors are Frederick A. Frick and James MacCoy, of New York, and J. Louis Wills and William H. Ried, of Rochester.

The jewelry store of Albert Beck, 117 Clinton St., Buffalo, N. Y., was broken into a few nights ago, and a revolver, several scarf pins, a number of watch chains, hair brushes and cigar holders were stolen. Detectives subsequently arrested Frank Carney, 18 years old, and John Rubato, 19 years old, for the crime. Part of the stuff was in their possession. The boys admitted the theft.

The jewelry store of J. W. Mealy, Son & Co., 9 S. Charles St., Baltimore, Md., has been enlarged and remodeled, and the interior of the structure has been rear-

ranged artistically. Excellent judgment has been displayed in the lighting, casing and ceiling, and a rich appearance is given to the fittings by the mahogany finish. The firm started in business a few months ago, and the store has been increased to double its former size.

Moore & Winder, Troy, N. Y., under date of Dec. 2, issued a card announcing that the co-partnership theretofore existing between Charles H. Moore and George Winder, under the firm name of Moore & Winder, was that day dissolved by mutual consent. George Winder is entitled to receive payment of all debts owing to said co-partnership and will pay all debts owed by it. George Winder will continue the business at the same place, 351 Broadway.

## Another Victor.

When the crucial test comes, when quality tells, side by side with the conquerors Olympia and Raleigh stands

## THE BOSTON.



O size, 3 rows of pearls, made in Montauk,  
20 years' guarantee, and 14 F.K.,  
25 years' guarantee.

**Joseph Fahys & Co.,**

Established 1857.

FAHYS BUILDING, NEW YORK.

THE EMPIRE WESTWARD TAKES ITS WAY

# WESTERN SUPPLEMENT

## THE JEWELERS' CIRCULAR

VOL. XXXIX.

NEW YORK, WEDNESDAY, DECEMBER 13, 1899.

No. 20.

### Chicago Notes.

*All communications in reference to the Chicago department of The Jewelers' Circular, addressed to Stephen Parlin, 1522 Lill Ave. (Telephone, Lake View 397), Chicago, will receive prompt attention.*

Mr. Fowler, of the Aurora Silver Plate Co., Aurora, Ill., was here on business last week.

M. N. Burchard is spending the week at factory L, of the International Silver Co., at Wallingford, Conn.

C. A. Kiger & Co., Kansas City, Mo., were here at the close of the week looking for goods for immediate delivery.

J. C. Leppart, 244 W. Madison St., is able to again look after his business, having entirely recovered from a long attack of typhoid fever.

After a week's confinement at home by reason of a sprained arm, sustained in a fall, Guy Happel, of F. C. Happel Co., has returned to his business duties.

Frank Bowe, for 20 years in the packing department of the Waterbury Clock Co., is seriously ill at his home with spinal meningitis, which tends toward paralysis.

George High, who left Otto Young & Co. two years ago to accept a position with F. Lewald & Co., has returned to Otto Young & Co. to take charge of the optical department.

"This has been the busiest year we have had in many years," remarks F. L. Merrick, Chicago manager for Bradley & Hubbard Mfg. Co. "Our new finishes took well and we are still very busy cleaning up orders."

A final meeting of the creditors of Hauenstein & Co., Lima, O., was held Saturday, and a declaration of dividend will be made within 10 days. The assets and liabilities of the firm are not known here, but there are only a few small claims held by Chicago parties.

James Chalmers, formerly a stockholder in several large concerns and now a book-keeper confessed insolvency in the United States District Court, a few days ago, in a petition in which he placed his liabilities at \$497,867, with no assets. The petitioner was formerly connected with the Chicago Watch Co.

Monte Gluck, for many years with Otto Young & Co., but who has had a try at the retail trade as salesman in the diamond department of a large State St. retail jeweler, has gone back to his first love. He will resume his position as house salesman for Otto Young & Co. for the holidays, and go on the road in February.

The trial of Alexander Ramm, on the charge of larceny as bailee, was put on the court call a week ago, but has been postponed until after the holidays. Ramm secured about \$3,000 worth of diamonds from S. K. Huston, a diamond dealer in the Champlain building, some months ago, and asserts they were stolen from behind a picture frame in his house while the family were absent. He had secured them to show to a prospective customer.

The banquet committee have decided that the members and friends of members of the Chicago Jewelers' Association shall dine on Jan. 19, 1900. The hall in which the banquet will be held is yet under consideration. A most important matter in regard to the banquet has been settled by the selection and acceptance of Frank O. Lowden as toastmaster. Those of the trade who have attended former banquets and heard Mr. Lowden in less important roles will warmly approve his selection as master of ceremonies. The list of speakers is not yet far enough advanced for publication, but promises a rich treat.

There were 1,317 rating inquiries sent to the office of the Chicago Jewelers' Association, in November, and 3,928 reports were furnished members in that month. This required the sending out of 765 letters and kept Mr. Hurd and his assistants exceedingly busy. December promises an even larger number of inquiries. This indicates that the Chicago trade is spreading out and reaching into new territory for this market. The increase includes new firms in old territory and customers seeking goods in this market from States tributary to other commercial centers. There were a few from even the more eastern of the New England States.

There were a good number of buyers here in person, considering the active trade retail jewelers are now having at home. Among them were C. A. McGregor, Pontiac, Ill.; Mr. Howard, Frankfort, Ind.; W. H. Thorpe, Beaver Dam, Wis.; Mr. Finberg, Ironwood, Mich.; E. H. Carpenter, Burlington, Ia.; J. F. Lindvall, Moline, Ill.; Charles Veuve, Peotone, Ill.; Mr. Volkman, of Volkman & Wambach, Kankakee, Ill.; E. C. Pike, Kankakee, Ill.; H. M. Newell, Coal City, Ill.; W. S. Heifelfinger, Carroll, Ia.; Mr. Young, Rock Island, Ill.; Mr. Harker, Plainville, Ia.; Charles Geishert, Niles, Mich.; T. J. Dale, Kenosha, Wis.; H. Fast, Milwaukee, Wis.; J. W. Burkitt, Arlington Heights, Ill.; R. S. Trask, Ottawa, Ill.; Rovelstad Bros., Elgin, Ill.; T. H. Anderson, Bluffton, Ind.; D. S. Hewitt, Toulon, Ill.; W. H. Evans,

Red Oak, Ia.; H. C. Klein, Muncie, Ind.; Fred Eynatten, Peoria, Ill.; J. E. Haep, Montpelier, O.; J. W. Crouch, Fowler, Ind.; Mr. Bird, Aurora, Ill.; Frank Schron, Whitewater, Wis.; C. E. Dodge, Walnut, Ill.; C. J. Linden, Kankakee, Ill.; S. B. Turner, Cassopolis, Mich.; J. R. Losey, Plymouth, Ind.; Mrs. Spalding, buyer for L. C. Garwood estate, Champaign, Ill.; Carl Oesterle, Joliet, Ill.; H. H. Speck, Milwaukee, Wis.

### Cincinnati.

#### TRADE CONDITIONS.

Very few of the jobbers will be able to comply with their customers' request for selection packages this year, as goods are being rapidly sold and the stocks so depleted that they will not have any to spare. Most of the jobbers have sent out word that they can not give out any this year. It is surprising how few are asking for them this year, which is certainly an indication that they have been able to buy their own stock and will not depend on the jobbers for samples for holiday display.

Harry R. Smith, the old time jeweler, renewed his bond as Southern Railroad trustee for the next five years for the sum of \$100,000, with David Sinton, the multimillionaire, and J. Burgoyne as sureties.

Jennie Painter, an old time thief, has been placed behind the bars where she will stay until after the holidays. She is rated as an expert shoplifter, and the authorities are afraid to let her out while the stores are crowded during the holiday season. She makes a specialty of jewelry.

Visiting jewelers in Cincinnati last week were: M. Clark, Anderson, Ind.; Mr. Sidwell, Elwood, Ind.; Chas. Sieglitz, Vevay, Ind.; Geo. W. Keifner, Loogootee, Ind.; H. Bertrams, Augusta, Ky.; Frank Emmerling, Hillsboro, O.; E. Israel, Harrison, O.; Chas. Crites, London, O.; A. Waller, Hartford City, Ind.

A new material house will be one of the 1900 innovations. The Messrs. Thoma, well known jewelers of Piqua, O., have leased the second floor of the Oskamp building, and are putting it into shape for the opening, Jan. 1, of a well equipped material and tool house. Fred Thoma, who has been traveling for A. G. Schwab & Bro., has notified that firm of his withdrawal the first of the year, and he will be associated with his father in the new concern. J. Shambaugh, who has been with Joseph Mehmert, has severed his connections with that firm and will take Mr. Thoma's place with A. G. Schwab & Bro.

**Detroit.**

Burglars last week stole \$200 worth of watches and cutlery from Gidding's general store, Sand Lake, Mich.

W. F. Guile, formerly of Cheboygan, Mich., but later at St. Ignace, has removed his jewelry business back to Cheboygan permanently.

H. A. Harrison, Sault de Ste. Marie, Mich., is closing out his stationery stock with a view to enlarging his jewelry department to the full capacity of the big store.

R. J. F. Roehm entered the jewelry business in Detroit 50 years ago last Tuesday, when he was 14 years of age. He is one of the oldest and most successful business men in the city and received many congratulations on his success and good health.

G. L. Lowe, manufacturers' agent, with headquarters in this city, left for north Michigan last week for the last trip before the holidays. He says that the jewelry trade in large cities is excellent, but in small towns collections are poor and the retailers are conservative in placing orders. Stocks are low, comparatively speaking.

Traub Brothers have conceived and executed some very pretty window displays with tinsel and the bowls of silver and souvenir spoons. The latest is a dazzling star and crescent, suspended in the center. It consists of a crescent of white wire attached to which are spoons tied with white ribbon. The wires are concealed by tinsel. At the proper point is a star of the same material, under which is a white dove. On the lower point is a cupid.

**Omaha.**

All the jewelers are employing an extra force this month. Mawhinny & Holliday have added 12 clerks.

Mrs. Lee Simpson, of Kansas City, has opened an optical establishment at 1902 Farnam St., this city.

A. I. Agnew, manager of the Columbian Optical Co., is in New York on business and pleasure.

Fred Harris, who has been attending the Omaha Horological School, has been engaged by F. Lemon, Ashland, Neb.

C. L. Shook, who has been very ill for 10 days, is able to be out, although not to attend to business.

C. L. Trout, New York, was in Omaha last week. Henry Jacobson, of Jacobson Bros., New York, spent several days in the city last week.

J. H. Hardin, manager of F. A. Hardy & Co., Chicago, passed through Omaha last week on his way to Denver, Col., to look after the interests of their branch house in that city.

Roy Given, implicated in the burglary of the Columbian Optical Co. store, was set free to go to his father in Nebraska City, the Judge thinking that would be better than to send him to the reform school. He is 15 years of age.

Recent customers here were: Harry Baker, Horton, Kan.; L. E. Burriss, Elliot, Ia.; W. F. Laraway, Glenwood, Ia.; A. F. Zimmer, Nebraska City; Mr. Sampson, of Farnum & Sampson, Blair, Neb., and Mr. Phillips, of Deadwood, S. D.

August Wetteroth, St. Joseph, Mo., will leave the first of the year for a three months' visit to Texas. His son, who located in Memphis, Tenn., a year ago, has returned to St. Joseph to look after his father's business in the meantime.

In an altercation Wednesday last between G. C. Porter, a newspaper correspondent, and Albert Edholm, jeweler, in the latter's store, Edholm was seriously wounded in the face. He says Porter shot him, but Porter insists that he did not. Porter was arrested and released in \$1,000 bond.

Mrs. Dr. Burdette, Lincoln, is taking a course of optics in the horological school; Dr. Lee Simpson, Kansas City, a course in watchmaking and engraving; W. R. McLaughlin, Omaha, a course in optics. Other new students are George Coe, Clearfield, Ia.; I. L. Morgan, Harland, Ia., and James E. Arthur, Chanute, Kan.

Fred Beal, who was sentenced in Des Moines, Ia., to seven and a half years in the penitentiary for trying to steal a tray of jewelry, worth \$1,500, from the St. Joseph jewelry store, was an Omaha boy and his true name is Fred Heins. His father was a prominent politician in his lifetime, and his mother brought strong influence to bear upon the Governor to secure a pardon for the young man. His father was at one time Treasurer of Douglas county. Heins is only 20 years old. When the Judge sentenced him he said that this was one of the most daring attempts at robbery he ever knew, and he believed the young man was only one of a gang of thieves, although he maintained that he alone was implicated. As he had not been in Omaha for three years the Judge would not accept testimony of Omaha men as to the boy's good reputation.

**Columbus, O.**

F. F. Bonnet has been appointed chairman of the committee on invitations for the inauguration of Gov. Nash.

Harry McLeod, alias Harry Kennedy, is under arrest at Parkersburg, W. Va., on the charge of stealing a lot of jewelry from Isaac Kopelman, jeweler, Toledo, and it is thought he may have had something to do with the diamond robbery at the store of Sigler Bros. Co., Cleveland.

P. C. Krouse took a very peculiar manner to collect a debt last week. Joe Silver, a tailor, owed him \$45, which he was not able to collect, and an attachment was gotten out against him. Silver was found in a restaurant, and the constable took his hat and coat that were hanging on a hook.

Peter Koch, jeweler, met with a very painful accident a few days ago. He was unloading a revolver when one of the shells exploded and the ball plowed through the palm of his hand, making a very ugly wound. It is now slowly healing, and he will be well in a short time if no complications set in.

The store owned by Isaac Kleeman, just moved from the viaduct to 166 N. High St., has been transferred to the Columbus Jewelry Co., of which Mr. Kleeman is the principal owner. He purchased the goods and good will of this company some time ago, after it became involved in debt and was put in the hands of a receiver.

**Pittsburgh.**

The auction sale of the stock of George W. Biggs & Co., recently purchased by Henry Terheyden, has begun.

Early one morning last week smoke was discovered issuing from the cellar of Henry Terheyden's store, 530 Smithfield St. Fire was discovered in two barrels of waste paper and a still alarm was sent in. No damage was done. An unlocked door from the cellar to the street occasioned apprehensions of attempted burglary, but there was nothing found on which to base suspicions.

Dealers from nearby towns last week were: D. S. Pelton, Sistersville, W. Va.; C. C. Marsh, Sistersville, W. Va.; N. L. Marsh,

**ABSOLUTELY THE BEST.**



1 DWT.

**EASY-FLOWING**

**GOLD**

**SOLDER**

**Best on Earth**

Manufactured by F. H. NOBLE & CO.,

103 State St., Chicago.

Sold by all Jobbers.

**Georgian STERLING SILVER.**

In Complete Table Service—



COFFEE SPOON.

French Gray Finish.

**TOWLE** MANUFACTURING CO.,

CHICAGO.

NEWBURYPORT, MASS.



Mannington, W. Va.; Bert Kurtz, Dawson, Pa.; W. F. Hasinger, Blairsville, Pa.; F. N. Marshall, Derry, Pa.; S. B. Craig, Noblestown, Pa.; J. V. Rosendahl, Irwin, Pa.

James Reilly, alias John Robinson, the diamond thief, pleaded guilty to larceny and entering a building to commit felony, in Criminal Court before Judge J. W. White. Judge White said: "I could give you seven years on this indictment, four years for entering a building and three for larceny. I will sentence you to the penitentiary for four years." A second thought that such a sentence would free Reilly in the Winter time prior to the busy holiday season, and his attorney's plea finally induced Judge White to make the sentence for three years and nine months. The two "stalls" whose pictures were in last week's CIRCULAR are still at large and have been admitted by Reilly to be his confederates.

### Indianapolis.

George A. Fletcher, jeweler, Fairmount, Ind., is town clerk and treasurer.

Dec. 6 a fire broke out in the apartment house in which Silas Baldwin, of Baldwin, Miller & Co., lives. He suffered some inconvenience and a slight loss.

On the night of Dec. 6 burglars broke into the room occupied by Smith & Grey, jewelers, Commercial building. Most of the stock was locked in a large safe. Only a watch and a few dozen spectacles were carried off. Loss, about \$100. The money drawer was broken into, but it was empty. The safe had only been in use two days.

Holiday buyers in the city last week included: Monroe Ewing, Ridgefarm, Ill.; Mr. Kersey, of Campbell & Kersey, Darlington, Ind.; L. J. Mayer, Thornton, Ind.; Shelburn Brothers, Zionsville, Ind.; E. B. Scott, Sims, Ind.; S. J. Saylor & Son, Rossville, Ind.; C. A. Bassett, Anderson, Ind.; W. H. O'Rear, Jamestown, Ind.; J. E. Ward, Worthington, Ind.; Mr. Carpenter, of Allen & Co., Hagers-town, Ind.; J. W. Hudson, Fortville, Ind.; A. W. Owen, Greenwood, Ind.; B. Maier, Edinburg, Ind.; J. W. Thompson, Danville, Ind.; H. T. Scharf, Center Point, Ind.; Byron Ash, Chrisman, Ill.; Chas. M. Hunnicutt, Rockville, Ind.

### Cleveland.

Mrs. Antoinette Muhlhauser won a suit last Tuesday, begun against her by E. J. Pinney, assignee of Brunner Bros., to collect \$369.70, alleged to be due for jewelry. Mrs. Muhlhauser claimed that she had paid the bill.

Private Detective Jake Mintz says that the Sigler diamond robbery was committed by the same man who stole \$1 from the stamp window of the post office about a year ago. Mintz also says that the police know the name of the man. He is one of the cleverest crooks in the country.

Saturday evening a man entered the jewelry store of H. L. Long, 80 Superior St., and asked to see some watches. A number were placed on the show case, and then the man asked to see one in the window. While the proprietor was getting the watch from the window the man took one of the timepieces from the show case and ran out of the door and across the via-

duct. He was not caught. The police were notified of the robbery. The stolen watch was worth about \$15.

### St. Louis.

#### TRADE CONDITIONS.

Retail jewelers report excellent trade, and anticipate one of the largest Christmas trades in years. Jobbers note a similar condition of affairs.

A. L. Spalding, a graduate from a local watchmaking college, has started in business at Jacksonville, Ill.

Among out-of-town jewelers here last week were: Robt. Tetley, Farmington, Mo.; Otto Rink, Carlyle, Ill.; C. Keyler, Nashville, Ill.; H. G. Knecht, Evansville, Ill.; S. C. Schneider, Bonne Terre, Mo.; T. G. Burckhardt, Jefferson City, Mo.; George Carroll, Virden, Ill.; John Roark, Winchester, Ill.; Geo. F. Longnecker, Winchester, Ill.; J. C. Johnson, Mt. Sterling, Ill.

Thos. D. Witt, executor of the estate of E. J. Cuendet, having resigned the office and turned over to his successor, Eugene R. Cuendet, the property of said estate, which included a large majority of the shares of the stock of the E. Jaccard Jewelry Co., has also resigned the presidency of this company and retires from the business. Eugene R. Cuendet, having been appointed administrator of the estate of E. Cuendet, has been chosen president of the E. Jaccard Jewelry Co., to fill the vacancy.

### Pacific Northwest.

Chas. Tempel, jeweler, Hood River, Ore., will move into his new store room this week.

A paper published at Enterprise, Ore., says there is a good opening at that place for a jeweler.

J. H. Peare's jewelry store, La Grande, Ore., has just been attractively repainted and remodeled.

H. A. Myers is having a building remodeled at Medford, Ore., which when completed he will occupy with a stock of jewelry.

W. A. Ingalls, South Bend, Wash., returned last week from a trip to San Francisco, where he went to purchase new goods.

W. D. McGloughlon, jeweler, of Dover, Del., has rented a store in the Maxwell building, Everett, Wash., for a jewelry business.

Sol Davidson, who has run for some time a jewelry repair shop at Cottage Grove, Ore., has put in a case of jewelry and a stock of clocks.

Fritz Abendroth, jeweler, Portland, Ore., mourns the loss of a diamond ring valued at \$100. Two men entered the place, leaving a cheap ring to be repaired. While there Abendroth showed them a tray of rings, and after their departure discovered the valuable diamond missing.

### Kansas City.

L. S. Cady, of Cady & Olmstead, has given a realty mortgage for \$13,000.

J. N. Warner, traveler for Oppenheimer Jewelry Co., has just returned from an

extensive western trip and reports business as very brisk.

M. N. Morrison's store, Pittsburg, Kan., was robbed last week of seven gold watches and some chains, thieves securing entrance through a rear transom.

The department store managers have arranged with the Supreme Court of the State so the new license law will come up about the first of the year and be soon settled definitely one way or the other.

A. F. Tucker, of the Tucker & Parkhurst Co., Ogdensburg, N. Y., was in the city all last week considering the inducements offered him for moving the company's factory here. This city is one of half a dozen cities visited. Mr. Tucker said he was very well pleased with Kansas City and her business outlook, and also with the fact of her large growing trade with Mexico.

### San Francisco.

#### TRADE CONDITIONS.

These are busy days with the jobbers and manufacturers. The greater part of the holiday orders are now in, and an effort is being made to fill them. Only a few buyers were in town from the interior last week, but a goodly number of hurry orders were received by mail and telegraph. Within the last few days, several telegraphic orders of large and small size were sent east. Opticians report an unusual demand for silver mounted opera and field glasses for holiday gifts.

Isadore Lewis, whose removal from 6th St. to 9th near Market, was noted last week, has completed the alterations in the new store and now has one of the prettiest retail stores in the city.

James C. Fitzpatrick, a traveling jeweler, has been sentenced to 100 days in jail for failing to return a watch which he obtained for purposes of repairs from Miss Mary Rogers, of Oakland, Cal.

R. S. Lomax, who formerly had a general store at Paso Robles, Cal., and handled a small stock of jewelry, has failed. The stock was to be sold at auction on Dec. 7, for the benefit of creditors. F. W. Marvin, of this city, is trustee.

The Mission Jewelry Co.—Landa & Goodenough, proprietors—doing business at 2025 Mission St., this city, have dissolved. Mr. Goodenough has opened a store at 16th St. and Julian Ave. Mr. Landa has entered into partnership with Peter Christian, and will continue in business at the old stand.

### Pacific Coast Notes.

W. S. Bailey has succeeded Wint B. Ross, Pomona, Cal.

J. S. Spears, jeweler, Los Angeles, Cal., and Mrs. Seth W. Fancher were married last month.

A fire at Placerville, Cal., recently, caused a small loss to the jewelry establishment of Thomas Patton.

John Luckenbach, wholesale jeweler, Los Angeles, Cal., says he will discontinue business in that city on Jan. 1.

R. H. Witherel, watchmaker and jeweler, Redondo, Cal., is considering the prospect of starting a business at Monrovia, Cal.

H. J. Whitley, jeweler, 111 N. Spring St., Los Angeles, Cal., has purchased a large portion of the wholesale watch and jewelry stock of J. Luckenbach.



**Canada Notes.**

**TRADE CONDITIONS.**

The demand for silver ware is as pronounced as ever and the outlook for a good watch trade very encouraging, if buying conditions were more favorable to the retailer. The lumber trade is better than ever, with high wages, and a heavy demand for watches from the lumber camps can always be looked for under such conditions. The good times have induced a strong feeling of confidence, and dealers everywhere are expanding their business and carrying large stocks. The shortage in the watch supply will have a tendency to reduce trade in the line below the limit it would otherwise reach. The watch trade, in fact, appears to have reached something of a crisis, owing to the action of the American movement manufacturers in raising prices, and new developments may be looked for. Jobbers point out that the manufacturers in dealing with the Canadian market lose sight of the fact that while they are protected at home by a high tariff, the Canadian duty is only 10 per cent and that consequently Canadian buyers will not continue to pay prices fixed according to the U. S. tariff limit, but will import more largely from Europe. Swiss goods are coming in freely, and jobbers are beginning to look to that quarter especially for cheaper grades.

The retail jewelers of Montreal and district are prepared for the holiday trade, which they expect to be more than usually active. Times have been good this year, and this month it is expected that sales will be the largest ever reported.

In Manitoba, as well as in the east, the weather has been unusually soft for this time of year, and everybody is praying for frost and snow, and lots of it.

The death is announced of A. Paquet, jeweler, Quebec.

A. Wilson has opened a jewelry store in Havelock, Ont.

The assets of J. E. Gagnon, jeweler, Quebec, were sold on the 11th inst.

Alfred McNamara, watchmaker, St. John, N. F., has opened in business.

E. M. Buzzel, jeweler, Magog, Que., has sold out his business to Dr. W. W. Chalmers.

Judgment for \$108 has been obtained against Levy & Michaels, late jobbers of Halifax, N. S.

Mrs. G. H. Keeve, widow of the late G. H. Keeve, jeweler, Lindsay, died in Toronto, on Nov. 26.

C. W. Hughan, watchmaker, Lindsay, Ont., has given a chattel mortgage to W. J. Bragg for \$1,200.

Mary Sampson has registered as proprietress of La Compagnie D'Optique et Bijouterie de Quebec.

John W. Armstrong, jeweler, Lucknow, Ont., has given a renewal chattel mortgage to G. W. Berry for \$577.

The bankrupt stock of John Watson, Montreal, is being sold at the store formerly occupied by him on St. Catherine St.

The premises of John H. Cochran, jeweler, Tottenham, Ont., were entered one night recently and about \$40 or \$50 worth of jewelry stolen.

The remaining stock of Davis Bros. is being offered for the holiday trade at 191 Yonge St., Toronto, together with a quantity of newly imported goods.

The Whitby business of John S. Barnard, who recently bought out the stock of H. Davis, London, and removed there, is offered for sale.

N. M. Deveau, optician, has opened a branch store at 164 Yonge St., Toronto, across the street from his main establishment, for the holiday trade.

The first and final dividend to the creditors of W. H. Ferguson, Prescott, on lia-

bilities of \$1,930 has been paid, amounting to 3 $\frac{1}{2}$  cents on the dollar.

Dr. Thompson, optician, who has been traveling for the Globe Optical Co., Toronto, will open a wholesale and retail optical establishment in Winnipeg, Man., early next year.

Out-of-town buyers visiting the Toronto trade last week included J. Horn, Bowmanville; R. Robertson, Hagersville; C. A. Humber, Sr., Goderich, and J. R. Munshaw, Wingham.

The imports of jewelry and watches and manufactures of gold and silver into Canada through the port of Montreal for November amounted to \$43,214, compared with \$37,615 for the same period last year.

D. Arcand has been appointed curator of the estate of J. E. Gagnon, jeweler, Quebec. In 1893 Gagnon compromised at 30 cents on the dollar, an arrangement which, at the time, was not wholly favorably received.

Winnipeg clerks are pushing their movement for early closing with a vigor which augurs success. The proposal is to close stores at 6 o'clock on the first five business days of the week and at 9 o'clock on Saturdays.

Wm. T. Short, watchmaker and jeweler, will, in a few days, occupy a handsome new store one block south of his present place of business, 105 Gottingen St., Halifax, N. S. The new store has a large plate glass front and the interior will be handsomely fitted.

A. E. H. Grupé has returned from an extended tour through the eastern States

and maritime provinces in the interests of the Globe Optical Co., Toronto, and is at present engaged with N. M. Deveau, optician, Toronto.

The graduates of the November class of the Optical Institute of Canada were: M. D. Tugenhaft, Toronto; Miss C. Berkinthal, Toronto; A. J. Howell, M. D., Beamsville; H. B. Bridgland, Bracebridge, and M. C. Fenwick, Corea, Asia.

Considerable excitement was caused on the busiest part of St. Catherine St., Montreal, about half past 9 at night early last week, owing to the report that the building of Henry Birks & Sons, jewelers, was on fire. The soot had burned itself out, however, by the time the firemen had arrived, and their services were not required.

The Council of the Montreal Board of Trade has passed the following resolution anent the recent epidemic of burglaries: "That the frequency of successful burglaries in this city, and the failure of the police to prevent their recurrence, shows that the police force and detective service are incapable of fulfilling their duty of protecting property. That the Council of the Board of Trade therefore asks the City Council to take the necessary steps for the reorganization of the police force, with special reference to the improvement of its detective service."

The two mail robbers, West and Pender, who were captured in Halifax, N. S., about five weeks ago, in the act of looting bags of mail at the railway station, have been tried and found guilty, but



# Our New.... Jewel Case



has been pronounced  
by competent judges  
the best in size, shape,  
workmanship and fit-  
ting, in the market.

**Roy Watch Case Co.,**

Makers of **SOLID GOLD CASES,**

21 Maiden Lane,

New York.



TRADE-MARK REGISTERED.

Wm. Oscar Cornell.

Frederick W. Andrews.

Frank H. Andrews.

**CORNELL & ANDREWS,**  
**ASSAYERS,**  
**GOLD AND SILVER REFINERS,**  
**SWEEP SMELTERS.**

FINE METALS, JEWELERS' AND PHOTOGRAPHERS' CHEMICALS

WORKS: PROVIDENCE, R. I., AND MERIDEN, CONN.

Office: 15 Calender Street,

PROVIDENCE, R. I.

Telephone, 456.

P. O. Box 476.

sentence was suspended temporarily to give the prisoners a chance to tell where the bulk of the goods stolen had been hidden, but they refused to tell and were accordingly sentenced, West to 12 years in Penitentiary and Pender, who was not of age, to two years in a reformatory. Detective Wright and the Post Office inspector who have been working on the case since the arrests have so far recovered 22 silver watches, 15 gold and silver plated chains, four gold rings, several napkin rings and three brooches, besides a large quantity of other articles, such as silk handkerchiefs, neckties, etc. The sentence of West was a most severe one, but the Judge remarked at the time that the crime was one of the most serious in the calendar.

The case of Mrs. O'Neil (Evangeline Claire), charged with swindling different firms of about \$50,000 worth of jewelry, dresses, etc., was fixed for Monday, Dec. 11, at Montreal, when it was expected that Judge Sicotte would have returned from Chicago, where he went to take evidence in the case.

It is said that coast jobbers are now making a strong effort to secure a larger share of the Kootenay trade. The Yukon, Atlin and northern trade has increased business at coast cities so much during the past two years that the jobbers have not given as much attention to the southern interior trade as they otherwise would have done.

The principal jewelry stores of Montreal have now their front windows set out for the holiday trade, and, as this has been accomplished with much taste, they all look very beautiful. The advantages of advertising, too, are fully recognized, and the daily papers have been full of choice ads., those particularly noticeable being by Henry Birks & Sons, R. Hemsley, R. Sharpley & Sons, R. A. Dickson & Co., M. Cochenthaler, D. Beatty, J. B. Williamson. Over three columns of write-up are given to Henry Birks & Sons' store in last Saturday's *Herald*.

Two important arrests have been made by the Montreal detectives. Henry Dufresne, for about five years in the employ of Alfred Eaves, jewelry jobber, but who left his service about four months since, is charged with and has pleaded guilty to having stolen about \$200 worth of valuables from his late employer. Armand Lamberge was arrested for receiving stolen goods. A quantity of rings, studs, links, gold pens, pencils, and ornaments of various kinds was found in his possession, and he has also pleaded guilty. It cannot be ascertained to what extent the thefts have been carried on. Mr. Eaves says that \$500 or \$1,000 worth may have been taken

Clark & Carnahan, Bentonville, Ark., have dissolved by mutual consent.

F. W. C. Folkers, La Crosse, Wis., has moved his jewelry department from the store of the Wilhelm-Nelson Carpet Co. to the drug store of Cargen & Young.

W. C. Sherman, Orlando, Fla., left Dec. 1 for New York and Boston on a business trip which will occupy his time for a month. On his return Mrs. Sherman, who is now in Boston, will accompany him.



**Eliassof Bros. & Co.,**

IMPORTERS AND JOBBERS OF

**DIAMONDS, WATCHES, JEWELRY,**

9-11-13 Maiden Lane,

NEW YORK.

Materials, Tools and Optical Goods.

ALBANY OFFICE: 62 &amp; 64 STATE STREET.

**Stern Bros. & Co.,**

Cutters of . . .

MANUFACTURERS OF

**DIAMONDS, Gold Rings and Thimbles,**

68 NASSAU STREET, NEW YORK.

RING FACTORY, 33-43 GOLD STREET, NEW YORK.

LONDON OFFICE, 29 ELY PLACE.

DIAMOND-CUTTING WORKS, 142-146 W. 14TH ST., NEW YORK. CHICAGO OFFICE, 149 STATE ST.

**WM. H. BALL & Co., Our Specialty:**

MANUFACTURING JEWELERS,

Anderson Building, 12-14-16 John St., N. Y.

**B14**  
TRADE MARK

**Everything in  
Gold Bracelets.**

Curb Bracelets, Bangle Bracelets, Fancy Stone Bracelets, Baby Esther Bracelets, Bracelet Mountings.

**BUY**  
**"SIMMONS" CHAINS**  
**THEY SELL!**  
 R.F. SIMMONS & CO.  
 ATTLEBORO, MASS.  
 N. Y. 9-13 MAIDEN LANE.

**WATCH CASE GUARANTEES.**

**THE RETAIL JEWELERS SPEAK OUT AND GIVE THEIR IDEAS ON AN IMPORTANT MATTER BEARING UPON THEIR TRADE.**

[This series of letters began in issue of Nov. 15.]

It was upon the request of several responsible jewelers that THE CIRCULAR entered upon the undertaking of obtaining a consensus of opinion from the retail trade regarding the guaranteeing of gold filled watch cases, and sent to a large number of jewelers, indiscriminately, a letter of which the following is a copy:

NEW YORK, Sept. 8, 1899.

WE ARE SENDING THIS LETTER TO THE RETAIL TRADE WITH THE OBJECT OF GETTING THEIR VIEWS ON AN IMPORTANT SUBJECT, NAMELY: THE GUARANTEEING OF FILLED WATCH CASES. FROM THE RESPONSES RECEIVED MAY BE EVOLVED SOME VALUABLE SUGGESTIONS.

OF THE FOLLOWING FORMS OF GUARANTEE, WHICH DO YOU CONSIDER MOST JUST, AND WHAT ARE YOUR ARGUMENTS ON THE SUBJECT?

1. SHOULD THE MANUFACTURER GIVE A NEW CASE OF THE SAME GUARANTEE IN EXCHANGE FOR THE OLD CASE THAT HAS NOT LIVED UP TO ITS GUARANTEE?

2. SHOULD THE MANUFACTURER EXCHANGE THE CASE THAT HAS NOT LIVED UP TO ITS GUARANTEE WITH ONE OF LOWER GUARANTEE? THAT IS, IF A 20-YEAR CASE HAS BECOME DEFECTIVE AT THE END OF 10 YEARS, SHOULD IT BE REPLACED WITH A 10-YEAR CASE?

3. SHOULD THE MANUFACTURER REPAIR THE CASE AND PUT IT IN CONDITION TO OUTLIVE THE UNEXPIRED TERM, IF THE CASE SHOWS THE BASE METAL BEFORE THE LIFE OF THE GUARANTEE HAS EXPIRED?

4. SHOULD HE GIVE A NEW CASE AND CHARGE FOR THE LENGTH OF TIME THE CASE THAT DID NOT LIVE UP TO ITS GUARANTEE HAS BEEN WORN; IN OTHER WORDS, REBATE FOR THE UNEXPIRED TERM OF GUARANTEE?

YOURS VERY TRULY,  
THE JEWELERS' CIRCULAR PUB. CO.

All those jewelers who did not receive this letter are cordially invited to send their views upon this subject, replying to the questions *seriatim* or collectively. Their replies will receive the same measure of consideration as those received direct from the letters themselves. The more views on this subject expressed by the trade at large the more convincing will be the conclusions reached.

[Fifth series of replies.]

CRESTON, Ia., Sept. 12, 1899.

Editor of THE JEWELERS' CIRCULAR:

Yours in regard to guarantees on filled watch cases at hand. Have carefully studied same, and in reply will say: First of all these questions are evidently prompted by the well known fact that the so-called filled cases that have been manufactured in the last 10 or more years are not in all instances filled as is understood by the James Boss patent, and that they will not and are not wearing anywhere near to their guarantee. Second. I do not think you are submitting these questions to the right parties, namely, the retail jewelers, who are only the go-betweens of those who buy and wear these cases and the manufacturers; and, of course, they would be conciliatory opinions which, however nice and sweet, are perfectly useless in deciding the points at issue.

With this idea I have to-day placed your

letter before some 20 different persons, all of them wearers of filled cases; some of them railroad men, some machinists, some office men and some farmers, and after they had read the same, asked them what would be satisfactory to them. Several had cases that were worn through; some warranted for 20 years that had only seen five to seven years' wear, and yet were worn out so far as looks and gold were concerned. Here is the consensus of their opinions: Fourteen for the 1st guarantee; none for the 2d; four for the 3d, and two said they would be satisfied with the 4th.

Now this is my opinion: The manufacturers should make their guarantee good as stated in the first instance, because the manufacturers know all the conditions to which their cases will be subject, and if the cases will not wear for the length of time under the worst of the conditions, they should not guarantee them. That they have to compete with each other in price is no excuse. Further, a man who buys a 20-year case and pays a 20-year price is entitled to have such a case; that it wears 10 years is no reason why he should not have a 20-year case at the end of the 10 years. He didn't buy a 10-year case, and if he has had the wear of the case the manufacturer has had the use of his money for what the customer never bought, or rather never intended to buy. The manufacturer knew the condition and fixed his price, accepted the money and took the responsibility, and if he is an honest man, should not try to crawl out not only from a manly and moral point, but from a future business point. He should put a 20-year case in the place of the case that has failed or of the grade the man paid for in the start.

What is one to think when he can hear traveling salesmen say to merchant Smith: "Now, Mr. Smith, these chains are warranted or these cases are warranted for 20 years or 10 years or five, as the case may be, by the manufacturers, but you and I know they won't wear that long. But they are as good as can be bought for the money, and it makes them sell better, and if one happens to come back why just give him another and the house will stand by you." Oh, yes, a nice proposition to go up against—a nice, honest proposition.

A guarantee should not be lightly given, and when given should be lived up to without a whimper.

I am not much of an expansionist, anyway, and am not in favor of it when it comes to expanding gold on a filled case till it is so thin it will not wear out its guarantee. Some of these cases are not filled so far as the rims are concerned.

Yours truly, H. BOWERS.

BUCYRUS, O., Sept. 12, 1899.

Editor of THE JEWELERS' CIRCULAR:

In reply to yours of the 9th, I would like to say considerable on the subject, but will confine myself to your inquiries. Would say no to No. 1. No. 3 is the most just proposition provided the cases are returned to the owners in not more than two weeks. If that cannot be done, No. 2 is the next best provided the case is of same quality. No. 4 cannot be considered at all, as the public would not put up with it. Respectfully yours,

F. B. KEHRER.

JEFFERSONVILLE, Ind., Sept. 12, 1899.

Editor of THE JEWELERS' CIRCULAR:

In answer to yours of 8th inst., beg to

say: The manufacturer of gold filled watch cases should give a new case of the same guarantee in exchange for the case that has not lived up to the guarantee. A case of a lower guarantee would necessarily have to be a cheaper article; a 10-year case when compared with a 20 or 25-year case has a very common appearance.

To give a new case and charge for the length of time the case that did not live up to its guarantee has been worn could not be done successfully; the owner may not have the necessary wherewithal to pay the difference, or he may feel that the old case was not a first-class one and that the dealer was trying to take advantage of him. If the old case can be repaired to outlive the unexpired term that should be perfectly satisfactory.

Yours truly,  
GEO. J. LIEBEL.

VALPARAISO, Ind., Sept. 12, 1899

Editor of THE JEWELERS' CIRCULAR:

Yours of the 8th received, and in regard to filled case business will say that I think it is time that something was done to change the plan, now in force, of giving a new case in exchange for one that has been worn from 5 to 18 years.

I had one customer who claimed a new case, under his guarantee, after it had worn 18 years, and he got the case. This certainly is an injustice to the manufacturer. I think manufacturer should only be liable for the length of his guarantee; that is, if the guarantee calls for 20 years and the case wears through in 10 years, he should only be liable for a 10-year case, and should not give a new 20-year case.

I think the customer should be given an option to take a case that will fulfil the guarantee not expired, or, if he wants the best case, let him take the best and pay the difference between the two. This I think would be fair to both parties concerned under the present system.

Personally, I do not think much of the present system of guaranteeing cases. There would be just as much sense in a shoemaker or a tailor putting a positive guarantee on his goods as there is in the system of guaranteeing cases. One person will wear out a pair of shoes in one-third the time that another will, and the same will hold true of cases.

I think that filled cases should be made and marketed the same as other merchandise, and the retailer and consumer should pay for what they get, that is for the amount of value in the article, and not have any guarantee, for the reasons named above. I think that under this system there would be just as many cases sold and each party interested would pay for just what value there was in the case.

Yours respectfully, GEO. F. BEACH.

MASON CITY, Ia., Sept. 18, 1899.

Editor of THE JEWELERS' CIRCULAR:

Perhaps it would be well to discuss the matter in two ways. As a matter of justice the manufacturer could not be asked to do any more than make his warranty good. As a matter of policy, it might be well to give a man a new case with as long a warranty as the original.

A very small percentage of the cases are sent in for redemption and a factory for its advertising can afford to be more than just. I would be in favor of making all filled cases as good as they are now and reducing the number of years of warranty.

We have too many cheap goods on the market now.

Yours,  
C. E. MANN.

(To be continued.)

**The Latest Patents.**

ISSUE OF DEC. 5, 1899.

**638,316. OPTICAL APPLIANCE.** EPHRAIM C. BRIDGE, Chariton, Iowa. Filed June 10, 1898. Serial No. 683,079. (No model.)

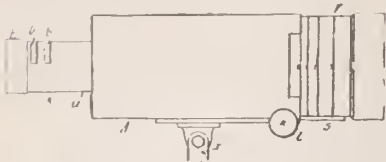

In an optical instrument, the combination of a main tube provided toward one end with a relatively small slidable tube carrying a negative lens, and provided toward its other end with a relatively large slidable tube telescoping the main tube, means for effecting the adjustments of these slide tubes, a plurality of converging lenses in the larger slide tube, and an indicating scale in connection with the latter tube and main tube.

**638,510. WATCH PLATE.** FELIPE HECHT, Geneva, Switzerland. Filed Nov. 18, 1897. Serial No. 658,911. (No model.)



In a watch, the combination, with a barrel-bridge provided with an extension having a recess or depression, and an abutment at the junction of the bridge and extension, of a winding-wheel supported above said barrel-bridge, and an expansile click-spring located in said recess, fixed against movement longitudinally therein, and engaging by its teeth the teeth of said winding-wheel, said click being provided at its outer side with a heel engaging said abutment, and the shank of said click-spring extending from the click adjacent to said heel along the recess-wall.

**638,525. MUSIC BOX AND EXCHANGEABLE MUSIC DISK.** MAX SCHLUSS, Leipzig, Germany, assignor to the Symphonion Mfg. Co., New York, N. Y. Filed Aug. 11, 1899. Serial No. 726,867. (No model.)

**638,618. COLLAR BUTTON.** WILLIS R. AUSTIN and WILLIAM N. CRAW, South Norwalk, Conn. Filed Jan. 27, 1899. Serial No. 703,564. (No model.)



A collar button comprising a base-plate, a shank rigidly secured thereto and provided with a disk lying in a plane at right angles to the axis of the shank and wholly at one side of the shank, said disk having a groove *4* across its face, and a head pivoted directly to said disk and eccentrically to the shank and having a spring which is adapted

to engage the groove so as to retain the head at either the receiving or holding position, said head having a flange fitting closely around the disk and shielding the same, said flange and head being rotatable relatively to the disk.

**638,641. TEA KETTLE, &c.** WILLIAM Mc-AUSLAND, Taunton, Mass., assignor to the Reed & Barton Corporation, same place. Filed Aug. 4, 1899. Serial No. 726,126. (No model.)

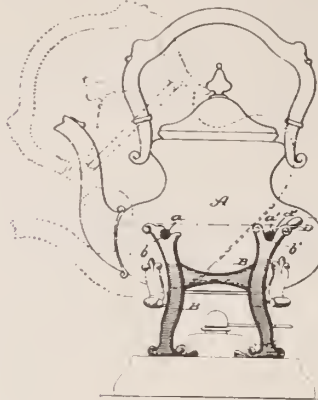

The combination with a supporting-base having two open trunnion-seats on each side, the front ones extending up and partially over the position of the trunnions; of a receptacle having two trunnions on each side, and a locking device arranged to secure one of the rear trunnions in its seat.

**638,660. NECKTIE FASTENER.** CHARLES BREVES and EDWARD CAPOUCH, Chicago, Ill. Filed July 24, 1899. Serial No. 724,912. (No model.)

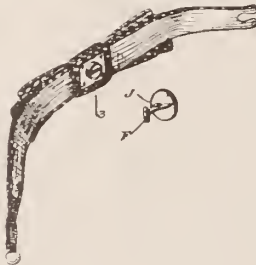

In a necktie fastener, the combination of the collar button having the horizontally-widened shank *J* and the vertical cylindrical head *F*, with the plate *A* adapted to fasten to a tie and having the raised boss *D* thereon provided with a depression *E* surrounding the horizontal aperture *G* which receives the head of the collar button when the parts are in abnormal relative position and prevents their disengagement when in their normal relative position.

DESIGN 31,920. CLOCK FRAME. CHARLES F.

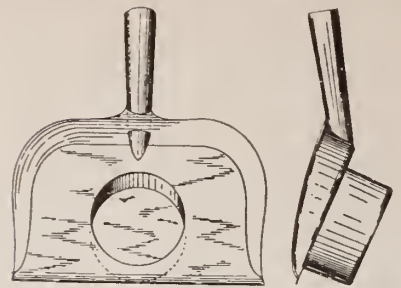

CHOUFFET and EDWARD J. ISLEY, Buffalo, N. Y. Filed July 15, 1899. Serial No. 724,002. Term of patent 3 1/2 years. TRADE-MARK **33,834.** SPY GLASSES AND DOUBLE OPERA GLASSES. JEAN BAP.



TISTE ALEXANDRE BAILLE, Paris, France. Filed Aug. 28, 1899. Essential feature.—The representation of a bee. Used since Dec. 21, 1896.

TRADE-MARK **33,835.** MEDALS AND BADGES. THE COLLEGE and COMMISSARIAT OF THE HOLY LAND, Brookland, D. C. Filed Nov. 7, 1899.

**CRUSADE.**

Essential feature.—The word "Crusade." Used since Aug. 1, 1899.

TRADE-MARK **33,839.** UMBRELLAS AND PARASOLS. ALLISON & LAMSON, New York, N. Y. Filed Oct. 24, 1899.

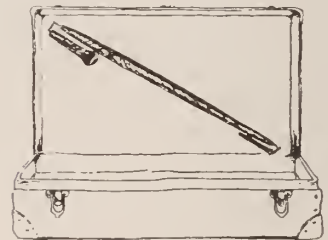

Essential feature.—The representation of an open dress-suit case, in which is placed an umbrella folded at each end. Used since Oct. 20, 1899.

**EXPIRED PATENTS.**

[Recently expired patents of interest to the jewelry trade. Reported especially for THE JEWELERS' CIRCULAR by R. W. Bishop, Patent Attorney, 728 Fifth St., N. E., Washington, D. C., who will furnish complete copies of patents at the rate of 10 cents each.]

- 268,831. PURSE. F. W. SCHWARZ, Offenbach-on-the-Main, Germany.
- 268,884. WATCH-MOVEMENT BOX. W. A. GUSTAFSSON, Chicago, Ill.
- 268,890. CLOCK STAND. GEO. HILLS, Plainville, Conn.
- 268,902. CALENDAR CLOCK. M. L. JACQUEMIN, Council Bluffs, Iowa.
- 268,911. CLOCK MOVEMENT. F. A. LANE, New Haven, Conn.
- 269,052. TORSION-PENDULUM CLOCK. ANTON HARDER, Ransen, Germany.
- 269,108. HANDLE FOR FLAT WARE. J. S. and ASHBEI RAY, East Haddam, Conn.
- 269,109. KNIFE. J. S. and ASHBEI RAY, East Haddam, Conn.
- Designs issued Dec. 8, 1885, for 14 years.
- 16,405. CARD RECEIVER AND STAND. M. S. CLARK, New York, N. Y.
- 16,412. FORK HANDLE. CHAS. WITTECK, New York, N. Y., assignor to Dominick & Haft, same place.
- Designs issued June 9, 1896, for 3 1-2 years.
- 25,600 and 25,601. POCKET BOOKS. P. O. DICKINSON, Newark, N. J.
- 25,604. CANE HEAD. J. T. MORRIS, Baltimore, Md.



GOLD SHELL.

"Buy direct from the manufacturer and get all that is coming to you."

SEND FOR OUR "HOT CATALOGUE, CONTAINING GOLD FACTS AND PRETTY PICTURES."

**CLARK & COOMBS.**

86 WEST EXCHANGE ST., PROVIDENCE, R. I.

WE ARE HEADQUARTERS FOR.....

**Gold Shell Rings...**



SAMPLE OF ENGRAVING DONE ON THE **Eaton-Engle Engraving Machine.**

CATALOGUE AND SAMPLE OF WORK FREE.

**EATON & GLOVER** have removed to the FULTON BUILDING, 87 NASSAU ST., Cor. Fulton, N. Y.



**ESSER & BARRY,** Largest Manufacturers of Imitation Diamond Jewelry in America. Cheap and Medium Priced.

Write us for samples of almost anything with an Imitation Diamond in it. MAIN OFFICE AND FACTORY, 101 SABIN ST., PROVIDENCE, R. I.

# OPTICAL DEPARTMENT.

Note.—From this week till further notice this department will be run as usual, viz.: every other week.

## Encyclopedia-Dictionary and Reference Handbook of the Ophthalmic Sciences.

Copyrighted 1898, by The Jewelers' Circular Pub. Co.

BY R. H. KNOWLES, M.D.

[Commenced in issue of July 6, 1898.—Continued from  
page 45, Nov. 29, 1899.]

### PART XLI.

**Ligament** (*lig'-am-ent*). [Latin, *ligare* = to ligate or bind.] A compact band of connective tissue, the purpose of which is to connect the bones together or surround them as a capsule. Several ligaments are concerned in the anatomy of the eye. Among them is the Ciliary Ligament which consists of soft, porous tissue located at the sclero-corneal margin in a fold within the anterior chamber of the aqueous humor. This ligament is also called the *ligamentum pectinatum*. The Palpebral Ligament joins the cartilage of the lids to the orbit the same as the Tarsal Ligament. The External Palpebral Ligament unites the lid to the outer edges of the orbit. The Internal Palpebral Ligament covers an area including the upper maxilla to the inner margin of the lid. The Suspensory Ligament or Zonæ of Zinn surrounds the crystalline lens and holds it in place between the fibres of the muscle of accommodation. The Ligament of Zinn joins the lesser wing of the sphenoid bone to the internal, external and inferior recti muscles of the eye at their origin. The Canal of Schlemm is also a ligament which joins the muscle of accommodation at its origin to its firm, unyielding b-d, so that when the muscle contracts it may contract upon its origin as in the case of all muscles.

**Light** (*light*). [Middle English, *light* = light.] That agent whose action, when stimulating the retinal elements, produces sight. There are several theories advanced to explain this phenomenon. The emission theory of Newton takes the supposition that light consists of corpuscular elements which are emitted or thrown off by luminous bodies and give rise to the sense of sight when thrown upon the retinal elements. Christian Huyghens, of Holland, disputes this supposition and advances the undulatory theory, which supposes that light is the result of vibrations set in motion by means of luminous bodies and which are thrown off in every direction alike, with a maximum amount of speed to the number of 186,500 miles every second. Cosmical Light, the result of molecular vibrations of necessity does not depend upon luminous bodies at all. Tesla in his experiments has produced light without any reference to a luminous body, demonstrating that it is more than probable that light is entirely an individual thing and in nowise dependent upon the Sun or any other luminous body, although the Sun and other luminous bodies do pro-

duce the phenomenon which we call light. Maxwell has propounded his theory that an electromagnetic disturbance develops vibrations which are thrown off at right angles to the ray of light. Reflection Light depends upon the law that the angle of incidence is equal to the angle of reflection. The Refraction of Light applies to a ray of light, which traveling in an oblique path in passing from a rare to a denser medium, bends towards the perpendicular. The same ray of light in passing from the dense to the rarer medium will tend in a direction away from the perpendicular. Oblique Light is thrown upon the outer structures of the eye by means of a condensing lens so that those structures may be seen clearly and diseases and foreign bodies described and properly treated or removed.

**Limbus** (*lim'-bus*). [Latin, *limbus* = the boundary line.] The extreme outer edge of a body or organ. The Limbus Corneæ is the sclero-corneal margin of the cornea or the extreme outer edge of that body. The Limbus Luteus describes the border of the macula lutea or the outer edge of the sight area or Spot of Saemmering.

**Limitans** (*lim'-it-ans*). [Greek, *limen* = the entrance of a door.] That which limits or bounds a body or organ. The Membrana Limitans Interna, or the internal limiting membrane, is the first of the ten layers of the retina (Gray), while the Membrana Limitans Externa, or the external limiting membrane, is the tenth layer of the retina which lies imbedded within the pigmentary element (Gray).

**Lippa** (*lip'-pa*) [Latin, *lippus* = a blurred eye.] A diseased state of the margin of the eyelids characterized by an inflammation in which the margins appear raw and bald as to the eyelashes, the eyelids being thick and covered with yellow crusts. Synonyms: **Blepharitis marginalis**; **Blurry eye**; **Lippitudo**.

**Lippershey, Hans.** Born in Germany about 1550. He was the inventor of the spy glass.

**Lippitudo** (*lip-pi-tu'-do*). [Latin, *lippus* = a blurred eye.] An inflammation of the margins of the eyelids. Synonym: **Lippa**. When this inflammation is located at the outer angle of the eye and is chronic in character it is called **Lippitudo Angularis** (*an-gul'-ar'-is*). [Latin, *angulus* = angle.] When the inflammation is specific in character and not only involves the palpebral mucous membrane but also the conjunctiva covering the globe of the eye of a newly born human infant, the disease is called **Lippitudo neonatorum** (*ne-on-a-to'-rium*). [Greek, *neos* = new + Latin, *natus* = one born.]

**Listing's law** relates to the various movements of the eyeball. The premises are taken that the angle of rotation is identical in the second position as the first position, as though the eye turned upon a fixed axis. Listing's Reduced Eye is an ideal emmetropic eye, showing that the two principal

nodal points are nearly the same. In this way the refractive surfaces are demonstrated for the dioptric mediae and the laws of refraction are thus easily simplified and demonstrated.

**Littrow, J. J.** Born in Germany 1781; died 1840. His writings include two important publications, "Maps of the Starry Heavens" and "Wonders of the Heavens." He was a professor of astronomy in several schools and was in charge of the Observatory at Vienna.

**Loemophthalmia** (*loem-oph-thal'-mi-a*). [Greek, *loimus* = a contagion + *ophthalmos* = the eye.] An inflammation of the superficial structures of the eye, due to a contagious element.

**Logadectomy** (*log-ad-ec'-to-my*). [Greek, *logades* = the white part of the eye in the sclera + *ekto* = out + *tome* = a cut.] A removal of a part of the conjunctiva by means of a sharp knife.

**Logades** (*log'-ad-es*). [Greek, *logades* = the sclera or white parts of the eye.] The first coat or tunic of the eye. Synonym: **Sclerotic Coat**.

**Logaditis** (*log-ad-i'-tis*). [Greek, *logades* = the sclera + *itis* = an inflammation.] An inflammation of the sclerotic eye. Synonym: **Scleritis**.

(To be continued.)

### The New Borsch Bifocal Lens.

PHILADELPHIA, Pa., Nov. 25.—A patent was granted Wednesday to John L. Borsch, manufacturing optician, 1310 Walnut St., for a new form of bifocal lenses invented by Mr. Borsch. A description of the new form of lenses was furnished to THE CIRCULAR representative by Mr. Borsch, who claims that they will have a great future.

"The improved form," said he, "consists of three elementary lenses. Each lens is accurately ground, the inner curves, of course, being made to absolutely coincide. The larger lenses are made of crown glass, or one of crown and the other of flint, while the small lens is always made of flint glass of a much higher index. These glasses present no indication of their method of construction, and look like a veritable puzzle to the uninitiated. The position and shape of the lenses allow one to walk, particularly up and down stairs, without difficulty. The lenses have been approved of by the members of the Section of Ophthalmology of the College of Physicians, of Philadelphia; by Dr. G. C. Harlan, who says he has been in the habit of using these glasses in operating as well as in reading and had found them entirely satisfactory, and by Dr. W. Thompson, who spoke in favor of these lenses both from personal experience and that of his patients. About a year ago I made a pair of bifocals in which for the usual presbyopic segment there was substituted a small lens 15 mm. in diameter, made of flint glass and sunk into the distance lens made of crown glass. The increased refraction, of course, of the small lens, depended upon the higher index of flint glass. Its exposed surface was ground to the same curvature as that of the larger lens."

### Is the Souvenir Pin to Become a Fad?

**F**EELING the need of a suitable souvenir to take the place of souvenir spoons, A. B. Griswold & Co., jewelers, 728 Canal St., New Orleans, La., offered



PRIZE WINNING DESIGN FOR LOUISIANA STATE SOUVENIR PIN.

to the art class of the H. Sophie Newcombe College, a college for women, New Orleans, a prize of \$15 for the best design for a souvenir emblematic pin. The young women fell to with zest, less to gain the emolument offered than to win distinction through their own originality and the acceptance of one of the many special drawings offered. A competent committee decided the merits of the large number of designs submitted, and after due consideration it was conceded that the most unique, graceful and meaningful of the drawings was that done by Miss Elizabeth Goelet Rogers, a senior of the Newcombe Art School.

The chosen design, of which an outline illustration much enlarged is here presented, can scarcely be judged by cold lines, the brilliancy of the enameled colors and the yellow of the gold adding much to the graceful outline. The fleur de lis of France in gold on splendid blue is the coat-of-arms at the left; that of Spain on the right in scarlet and yellow; these are representative of French and Spanish domination of Louisiana when she was their colony. The Louisiana State emblem, the pelican, surmounts these shields, and below them is the State motto, "Non sibi sed suis" (translation, "Not for himself, but for his own"). The make up of the pin artistically and as an example of the goldsmith's art is entirely successful, and will meet with the approbation of the home people, as well as strangers seeking an emblematic souvenir of the State.

Messrs. Griswold & Co., writing to THE CIRCULAR, characterize the design "as highly satisfactory in every particular."

**Varnish for Jewelry.**—Seed lac, 90 grammes; gamboge, 30 grammes; amber, 30 grammes; dragon's blood, 2 grammes; turmeric, 1 gramme; extract of saunders, 1 gramme; alcohol (95%), 600 grammes.

**Varnish for Cuivre Poli.**—Alcohol (95%), 1 liter; sandarac, 110 grammes; resin, 30 grammes; glycerine, 5 grammes. Dissolve the sandarac and the resin in the alcohol, then add the glycerine.

### Queries by Circular Readers.

**Note.**—Questions under this department will be answered as promptly as possible. Some queries require careful investigation before a satisfactory answer can be given; hence such answers are often seemingly delayed. THE CIRCULAR desires every jeweler to take advantage of this department.

DETROIT, Nov. 23, 1899.

Editor of THE JEWELERS' CIRCULAR:

Where can we secure copies of photographs from which half tones on first pages of THE CIRCULAR of Nov. 15 were taken? Yours respectfully,

ROEHM & Son.

**ANSWER:**—If correspondents will communicate with Ludwig Nissen & Co., 18 John St., New York, this firm will furnish all information desired regarding these photographs. This answers the several other inquiries to the same effect received on the subject.

ALBANY, N. Y., Nov. 21, 1899.

Editor of THE JEWELERS' CIRCULAR:

Can you inform me of any collectors of antiquated watches? I have a gold, French repeating watch, made by Bréguet, of Paris, in the year 1787. I wish to dispose of this watch at a reasonable price, and was requested by a resident watchmaker to inform you of the fact. There is a history connected with it. I would also like to know if any of Bréguet's heirs or representatives are living and where. Thanking you in advance, I am,

Very truly yours,  
Wm. S. DUGAN.

**ANSWER:**—The only collectors of old watches of whom we have record are: Edward A. Sweet, with Sussfeld, Lorsch & Co., 37-39 Maiden Lane, New York, and Prof. Calvin Rae Smith, of the College of the City of New York, New York. We understand that a Bréguet watch has no unusually large value, but may command a fair price from a collector who does not happen to have one in his collection. The grandson of Bréguet, Louis Bréguet, died in 1883, but we understand that a relative of the family is still in business in the Rue de la Paix, near the Madeleine, Paris. What his name is we do not know.

NEW YORK, Nov. 20, 1899.

Editor of THE JEWELERS' CIRCULAR:

Will you please inform me with what I can regild a large gold frame? Thanking you for the favor, Yours truly,

L. M.

**ANSWER:**—Rub the surface of the frame to be gilded smooth with shave glass or fine sand paper. Then carefully remove dust and grit, and apply a priming of glue size, two coats of oil paint and one of flattening. When the last coat of paint is dry it should be rubbed with a chamois skin, to free it from dust and grit. If any designs or figures are to remain ungilded, they should be painted with the white of an egg mixed with water. Gold leaf, which adheres to this, can be easily removed with a damp cloth. Then strain the sizing through a muslin cloth and place it in a saucer and add to it sufficient ochre, or vermilion, mixed with oil only, to give it color. Then, with a stiff camel's-hair brush begin to paint the surface, being careful to lay it on smoothly and not too thick, as in the latter case it would run and leave wrinkles in the gilding. In doing this, begin at the top of the frame and work from the left, downward. Paint lightly, but firmly, mapping out the surface to be sized into blocks, and finish each block before proceeding to another. If there are patterns to be left ungilded, carefully trace their outline with a black pencil and paint the enclosed surfaces with the white of an

egg mixed with water. When the surface is completely covered with the sizing, see that there are no faulty places; if there are, retouch the spots with a small camel's-hair brush previously dipped in the sizing. When very perfect gilding is required, the surface should be sized twice, the first coat being allowed to dry thoroughly before the second is applied. In carved work, be careful to brush the hollows of the carving. It is a good plan to allow the sizing to dry during the night, so that one can gild in the morning. But be sure that the sizing is thoroughly dry before proceeding farther. The readiness of it can be ascertained only by the touch. If when touched by the finger the surface daubs or comes off, it is not ready, but if it feels clammy or sticky it is sufficiently dry. If too dry the surface should be resized. When the sizing is in proper condition, dry the book of gold leaf before the fire for about one-half hour. This will render it more manageable. Then take a camel's-hair brush and draw it over the hair, so as to enable it to raise the gold leaf from the book. If the leaf curls, work it about with a dry brush or the blade of a knife. Then raise the leaf with the greasy brush and place it on the sized surface. As in sizing, work from left to right and be very careful so that each leaf overlaps the next, thus avoiding gaps and spaces. Lay on whole leaves wherever possible, and afterward gild the curves and corners which need smaller pieces. Be very careful when cutting the leaf and proceed as follows: Place a leaf flat on a pad or cushion, made for the purpose, and, taking the knife in the right hand, draw the edge easily and evenly along it with a gentle pressure. Divide the leaf into as many pieces and shapes as required, and lay on as before. When the surface is completely covered take a piece of cotton and gently dab the gold, after which the surplus is brushed off with cotton or a camel's-hair brush. If the camel's-hair brush is used, it will remove the marks of the joining and other small imperfections. Then smooth the gold with a soft piece of chamois skin, and the frame, or moulding, is set aside to dry. There is a particular state or degree of dryness, known only by experience, in which the frame, or moulding, is in a fit state for burnishing. The burnishers used by the gilder are either flint or agate, generally the former; the steel burnishers used by jewelers would not answer the purpose. The burnishers used are of different shapes and sizes, so that they can be adapted to the piece of work which is to be burnished. After burnishing, the parts which have not been burnished are weak-sized; that is, wetted with water in which a small amount of clear sizing has been melted; this helps to secure the gold. Finally, if any defective spots are seen repair them by taking small pieces of leaf and laying them on the faulty places, previously moistened with sizing. We would add that, if correspondent has one frame only which he desires to regild it would save him time and money if he would take it to a gilder at once, for we know of no other work which requires as much care and patience as gilding on wood. Besides, we know of frame gilders who cannot make their own sizing, but must buy it already prepared.

## VIEWS ON MERCHANDISING.

ADDRESS BY W. E. JENKINS, JEWELER, RICHMOND, IND., ON "CONCENTRATION AND SPECIALIZATION IN MERCHANDISING," BEFORE THE ECONOMIC LEAGUE.

### PART III.

[Continued from page 43, Dec. 6.]

SO much for the wrong; now for the remedy. The legislatures of several States have passed restrictive laws intended to harass and make unprofitable the business of conducting department stores by placing a cumulative tax on each additional line of goods carried above a certain number. This plan has been tried in Paris in the case of several large general stores without results. In Chicago a similar restrictive measure was set aside by the courts. Legislation of this class will fail of its purpose. In the first place, it is undertaken at the instigation of small merchants, who have their own interests at heart and not those of the public. So, instead of striking at the abuses of the yellow stores, fraudulent advertising, etc., these laws aim to do away with those features which are the source of legitimate economies, viz.: The handling of a variety of lines and the employment of large forces of sales people.

The legislation is framed by those without special knowledge of the situation and usually is demagogical compliance with popular clamor. It has yet to pass the courts anywhere, I think. If legislation be invoked at all it might effect a censorship of advertisements, though I have not much faith in the suggestion, and believe it to be unnecessary, as eventually the stormy uproar will fail to convince and quieter methods will follow.

On the grounds of public policy, shoddy merchandise should be branded, just as oleomargarine and other imitations are tolerated under the pure food laws, only when put up in distinctive packages, as inferior goods, shoddy and seconds form the bulk of the sales of the yellow stores, constitute the chief sources of profit (articles of established reputation, well known brands, etc., being handled usually as leaders to attract trade). In this way they would be seriously handicapped and the public would be protected.

They should not be permitted to employ children during the period of compulsory attendance at school. No substitute in the nature of a store school should be accepted, however good.

Sanitary conditions should be insisted upon, plenty of light and air, just as in the case of a public hall; short hours, and seats for the women clerks provided. I do not see how legislation can go further. What remains to be done must be done by enlightened and organized public opinion. The Consumers' League, with its white list of stores, where a certain minimum of consideration for employes is shown and living wages paid, will do more for the fumigation of the yellow store than legislation can. The Consumers' League is enlisted in a holy crusade, that should be reinforced from every pulpit in the country. The power of such a boycott was shown last year in Denver, when the whole population resented the effort of certain large

stores to dictate to the papers in regard to advertisements. The stores capitulated in less than ten days, after suffering enormous losses.

A feature of the merchandising situation which will tend to check the general stores is the successful conduct of large single line stores in central business districts. Every advantage save that of variety of merchandise they possess. The economic handling of goods at retail sale depends not so much upon the amount of business done in a variety of lines as the quantity of one kind sold. In this particular the large specialist has the advantage over the general store merchant, as he can concentrate his capital and attention upon one class of goods and make a better showing therein, than can the merchant who scatters both over 50 departments. The best methods of the department store have been adopted by the specialists, liberal advertising, small profits, close cash buying in quantity. If the general stores were closed by radical legislation these large, centrally located, single line stores would succeed to the bulk of their trade. It is not unlikely that they will grow in number and become a larger factor than heretofore.

Circumstances have favored the rise of the yellow store during the last eight or ten years. There has been in this period a very general overproduction of merchandise which the makers have had to dispose of, and in their efforts to realize they have naturally gone to those who were able to take the largest quantities and have sold their surplus cheap for cash. The yellow stores have been the dumping ground of large quantities of goods sold at a considerable loss to the manufacturer. With constantly narrowing markets there was for several years a constantly accumulating volume of merchandise distributed at a loss to the maker, and to the immense advantage of the department stores. They were prepared to take anything in any line provided they could get all of the lot at their own price.

"Give you half and take all you've got. How much have you got?" became a formula of the yellow store buyers. On these exclusive purchases large earnings were made. Another morbid condition of the business situation during the recent period of hard times has made for the advantage of the yellow store. I refer to the purchase of bankrupt stocks for 25 to 50 cents on the dollar, and the sale of them at retail at a corresponding figure. With the return of better times both of these sources of supply will be cut off in a measure, and the yellow stores will have to fall back on the advantage they possess by reason of size and higher specialization.

This advantage in normal times is real but not so overwhelming as their operations during the period of depression would seem to indicate, and they share it with the larger single line stores.

I believe that the progress of this vulpine type of store to an absolute control of the merchandising situation will be much less rapid in the future than in the past. Educated public opinion will learn to discriminate in favor of the merchant who gives uniform values, and who makes provision for the comfort of his employes. This coercion will extend to the conditions

of manufacture, and the sweat shop contractor will find his occupation gone. The larger stores will grow larger, and the yellow one will grow whiter. The small stores in staple lines not perishable will disappear from the cities, and their growth be checked in the smaller towns by the growing drift of merchandising to large centers. The exceptional small store merchant may by superior methods in some cases hold his own.

We know in the biological field, when some plant or animal is threatened with extinction, a happy variation on the part of some individual preserves the whole species with modified characters. Something analogous to this may happen to save the small merchant, but it must be confessed that there is nothing in the manifest tendencies of the present to justify such a hope.

"The individual must go," complacently announce those who would profit by his extinction. But if he disappear from the field of industry there must be some compensation to him in another capacity. If he give up his initiative as an industrial agent, he must be recompensed therefor. His individuality in other capacities must be protected and fostered. He must have a larger share in the material and spiritual product of his activity. He must become more of an individual instead of less; better educated, better clothed, better housed, with more leisure and higher recreations. His part in the social and civic activities must be larger. He must start in the competition on equal terms, and his proper reward must be insured him.

Nature has taken a thousand eons for the creation of the individual, and I cannot think that her mighty purpose will meet defeat. If anything be clear in the great stream of tendency we call evolution, it is that the individual is the favorite of the gods.

We who are afloat on the surface of the flood may mistake a petty eddy for the main current and err in regard to the direction of its flow, but the vast stream moves on, drawn by the gravitation of God's purpose, and by and by we feel the swell of the world wave beneath our vessel's keel and know that we are in His hand who decreed that man should be an individual, and He will preserve His own.

## JULES J. LINTZ, Watch and Chronometer Maker

FOR THE TRADE.

Two Diplomas and First Prizes for Scientific Workmanship.

108 Fulton Street, New York.

Downing Bldg., Room 1019.

Repairing of Fine and Complicated Watches  
Pocket and Marine Chronometers.

All kinds of New Pieces made to order and adjusted.

The Latest Designs and the Newest Shapes  
are to be found in

## CROWN 14 K.

GOLD-FILLED WATCH CASES.

Warranted for

## 25 YEARS.

# BRADLEY & HUBBARD MFG. CO.

Have produced for this season's trade  
the finest line of goods ever offered.

## Art Metal Goods,

PITCHERS, VASES, CANDELABRAS,  
FIGURES, BUSTS, TABLES, ETC.....

## Reception Lamps

WITH THE CELEBRATED "B. & H." and B. & H. RADIANT BURNERS.  
NEW AND ORIGINAL DESIGNS.  
HANDSOME AND EXCLUSIVE FINISHES.

*Dealers are cordially invited to inspect the line of Samples  
at our SALESROOMS.*

NEW YORK: 26 Park Place to 21 Barclay Street.

BOSTON:  
160 Congress Street.

CHICAGO:  
131 Wabash Avenue.

PHILADELPHIA:  
714 Betz Building.

FACTORIES and OFFICES: MERIDEN, CONN.

## SILVER NOVELTIES

### SIMMONS & PAYE,

"The Souvenir House,"

129 Eddy St., Providence, R. I.,  
will mail to any jeweler on request a  
copy of their latest catalogue, illus-  
trating manicure goods, toilet goods,  
and silver-mounted glass goods.

## THE LEDOS MFG. CO.,

MANUFACTURERS OF

## Watch Case Materials,

Crowns, Pendants, Bows, Solders,  
Springs, Findings, Etc.,

34-36 PEARL ST., NEWARK, N. J.



**SIMONS BROS. CO.**  
PHILA. NEW YORK CHICAGO  
SILVERSMITHS, JEWELERS.  
MAKERS OF GOLD AND SILVER THIMBLES.

## FERD. FUCHS & BROS., SILVERSMITHS,

MAKERS OF STERLING SILVERWARE,

34 East 29th St., - New York.

## WOOD & HUGHES,

Sterling Silverware Manufacturers,

FINE PLATED WARE,

No. 24 John Street, - New York.



**T. & B. ENGRAVERS**  
"Engravings attract, where Type is unnoticed"  
89 FULTON STREET.  
TELEPHONE 645-JOHN.  
New York, N.Y.

## H. M. RICH & CO., Jewelry - Auctioneers, 7 and 9 Franklin St., BOSTON, MASS.

## PAIRPOINT MFG. CO.

New Bedford, Mass.

### LATEST CONCEPTIONS

... IN ...

### Rich Cut Glass,

Silver  
Plate

... AND ...

Table  
Ware.

38 Murray St., New York City.

Temple Building, Montreal.

Established 1879. Manufacturer of

## LOUIS W. HRABA, Fine Leather Goods

29 East 19th St., New York. Exclusively for the Jewelry Trade.

## AIKIN, LAMBERT & CO.,

MANUFACTURERS OF

FINE GOLD PENS, HOLDERS, PENCILS,  
TOOTH PICKS and NOVELTIES.

PAUL E. WIRT FOUNTAIN PENS, at new and lower prices . . .  
MERCANTILE FOUNTAIN PENS, guaranteed to give satisfaction.

Catalogues with terms and discounts furnished to the trade.

BRANCH, 103 STATE STREET, - - - CHICAGO.

## AIKIN-LAMBERT JEWELRY CO.,

IMPORTERS OF

## DIAMONDS.

JOBBER IN

WATCHES, JEWELRY, CHAINS,  
NOVELTIES, ETC.

LATEST DESIGNS.

LOWEST PRICES.

19 MAIDEN LANE, NEW YORK.





**THE RAMBLER'S NOTES.**

WHAT THE RAMBLER SAW AND HEARD AMONG THE DEALERS IN ART POTTERY, CUT GLASS, BRONZES, ETC.

**THE POPULAR STYLE OF CUT GLASS.**

THE style of cut glass which is reported by C. Dorringer & Sons, 36 Murray St., New York, to be enjoying at the present time the greatest popularity among the principal dealers of the larger cities, is that which consists of a combination of stone engraving and deep cuttings. Though expensive, the glass of this style has continually increased in popularity during the last few months, and particularly the jugs, vases and flower bowls of green and ruby glass ornamented in this way. In the colored pieces the cuttings are at the bottom of the jugs and vases, while the stone engraving is above it, running up to the neck. The jugs so decorated are of many kinds and styles and are shown with or without silver mountings; the mountings being in oxidized, gilt or bright silver finish.

**BEER MUGS AND DECORATED GLASS.**

TWO lines which Endemann & Churchill, 50 Murray St., New York, are now pushing successfully with jewelers for the holiday trade, are their beer mugs and fine decorated glass ware. The beer mugs, as have before been described in this column, are of Flemish ware, in rich and artistic varieties that are not to be confounded in any way with the cheaper steins sometimes sold to the trade. The glass ware consists principally of decanters, glasses and similar novelties. The holiday season has produced a large demand for the many kinds of sets which this firm have put in satin lined cases. The principal decoration shown in this line is a new effect produced by metallic luster colorings and gilt scroll work.

**FIGURES FOR CHRISTMAS TRADE.**

THE jeweler who contemplates filling out his Christmas stock with figures of any kind, bronze, terra cotta or china, would do well to visit the show rooms of Lazarus, Rosenfeld & Lehmann, 60 Murray St., New York, whose display of these goods surpasses anything of the kind they have ever made before. A few of the lines in the figures are real and im-

itation bronzes, real and imitation terra cotta, Castellina and Carrara marbles, real and imitation bisque, Teplitz, Dresden and other effects. The larger terra cotta pieces now contain electric light fixtures, similar to but more striking in effect than the fixtures on bronzes introduced in the past few years. Entirely new subjects, as well as a host of new effects and decorations, are to be found in the bisque and smaller terra cotta pieces.

THE RAMBLER.

**The Antwerp Ivory Market.**

WASHINGTON, D. C., Dec. 7.—Consul-General Lincoln, at Antwerp, on Nov. 7, 1899, reports:

"At the fourth quarterly sale held on the 30th and 31st of October, the ivory offered and sold was as follows:

Kongo:	Pounds.
Hard .....	118,574
Soft .....	5,185
Angola .....	27,002
Gaboon .....	9,894
Kameroun .....	5,633
Senegal and Gold Coast .....	1,365
Zanzibar (soft) .....	904
Hippopotamus tusks .....	492

Total ..... 169,049

"The totals for the corresponding quarter of preceding years were:

	Pounds.
1898 .....	110,230
1897 .....	165,345
1896 .....	132,276
1895 .....	156,527

"The bidding was very active, and the prices advanced by from 19.3 to 29 cents per 2.2046 pounds for tusks of all weights, and about 10 cents for the scriverails and tusks for balls. These rises in price are more important than those which took place at the last sales in London. The oversizes remained at the price of the last sales; the tusks for bangles alone diminished in price by about 19.3 cents. The soft ivory advanced by from 38.6 to 57.9 cents. The stock on hand amounts to about 225,972 pounds, against 176,368 pounds in 1898, 134,481 pounds in 1897, and 136,685 pounds in 1896. The next quarterly sale will be held on the 6th of February, 1900."

Among new and handsome pottery is the Grueby ware made in New England and showing among its colors a peculiarly attractive dark green.

A useful bit of bric-a-brac is the time-piece in a crystal sphere. One lately seen was swung from chains held in the mouth of a watchdog in green bronze.

**OLD BRITISH POTTERY MARKS**

HOW TO IDENTIFY 17TH CENTURY AND 18TH CENTURY CHINA AND PORCELAIN.\*

[Commenced in issue of Nov. 15.]

**Worcester Ware.**

Nos. 1, 2 3 appear on all kinds of Worcester china from 1752 to about 1800. The crescent is the true Worcester mark; it was taken from one of the quarterings in the Warmstry arms.

Nos. 4 and 5.—The crescents with addi-

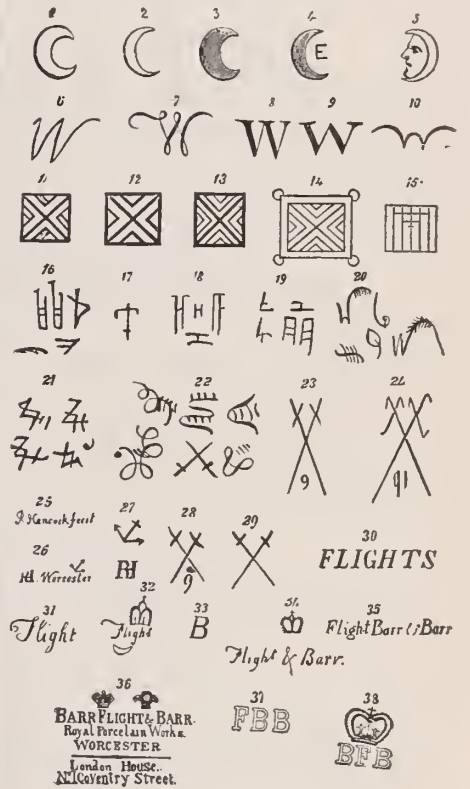

MARKS ON WORCESTER CHINA.

tions are not common; they are generally on blue ware.

Nos. 6, 7, 8, 9, 10.—The W mark is found on a great variety of patterns of early date.

Nos. 11, 12, 13 are the square marks so much sought after, and at present so freely forged.

Nos. 14, 15.—Also square marks, but not so common.

Nos. 16 to 22 are copies of Chinese and Japanese patterns, and generally appear on ware of that class.

\*Adapted from the Pottery Gazette.

# THE LADY RACINE

IS THE

## Best Chatelaine Watch

10 Line,  
11 Line,  
12 Line,  
13 Line,  
Hunting or  
Open Face,



Nickel,  
Steel,  
Silver,  
Enameled,  
Gold,

In new and tasty designs.

Can be ordered from all Reliable Jobbers.

### SILVER MEDAL AWARDED

... BY ...

NATIONAL EXPORT EXPOSITION, Philadelphia,

... TO ...



**C. F. Rumpp & Sons,** Established 1850.

PHILADELPHIA,

FOR

**HAND-CARVED LEATHER GOODS.**

SEND FOR ILLUSTRATED CATALOGUE.

These well-known Razors, the quality of which is warranted, possess this great advantage, that they may be used for ten years before they require actual sharpening. Before using them it is necessary to rub them on good leather strop. Le Coultre's Strops (to be had with the Razors) should be used in preference to others.

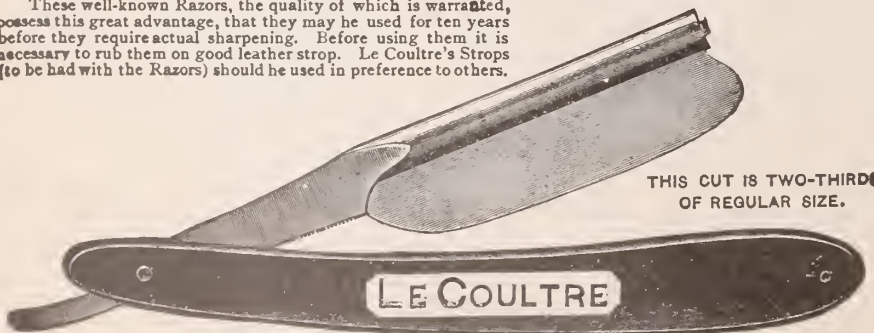

THIS CUT IS TWO-THIRD OF REGULAR SIZE.

"SPECIAL"—Single Razors for Jewelers' Travelers at trade price.

**MATHEY BROS., MATHEZ & CO.**

Send for Price List.

Sole Agents, 21 & 23 MAIDEN LANE, N. Y.

Nos. 23 and 24 and 28 and 29 are imitations of the Dresden mark, but they appear on many styles of ware, sometimes even on black print.

Nos. 25, 26, 27 appear only on black transfer prints between 1756 and 1774.

No. 30 has been found impressed in the ware 1783 to 1791.

No. 31.—In blue underglaze for the same period.

No. 32 appears on the Royal surface made for the Duke of Clarence.

No. 33.—This letter is found scratched in the clay after Mr. Barr was taken into partnership; from 1793 to about 1800.

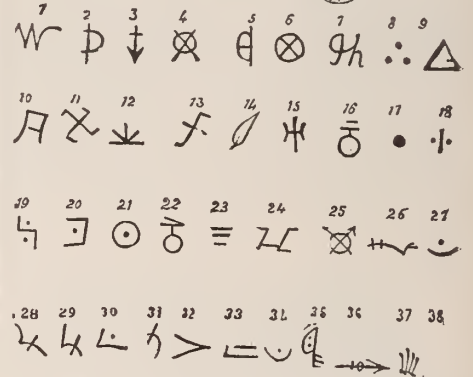

MARKS ON WORCESTER WARE.

No. 34.—From 1793 to 1807.

Nos. 35 and 37.—From 1807 to 1813.

Nos. 36 and 38.—From 1813 to 1840.

No. 39.—Used by Chamberlains, written with and without "Worcester," from 1788 to about 1804.

No. 40.—Written on specimens in 1814.

No. 41.—Printed mark used from 1814 to about 1820.

No. 42.—Printed mark used from 1820 to 1840.

No. 43.—Printed mark used between 1840 and 1845.

No. 44.—Printed mark used in 1847.

No. 45.—Used between 1847 and 1850; sometimes impressed in the ware, at other times printed upon it.

No. 46.—Mark used in 1850 and 1851.

No. 47.—Mark used by Kerr and Binns from 1852 to 1862.

No. 48.—Mark used by Kerr and Binns on special pieces.

No. 49.—Mark used by the present company from 1862.

[THE END.]

American  
Watch Case Co.,

**A.W.C.CO**

9-11-13 Maiden Lane,

Gill Building, New York.

**CROUCH & FITZGERALD,**



Jewelry Trunks  
and Cases,  
161  
Broadway,  
Bet. Cortlandt and  
Liberty Sts.  
688 B'way,  
723 6th Av.  
NEW YORK.

**DR. KNOWLES'**

...PRIVATE COURSE IN...

**Optometry.**

SPECIAL RATES IN THE  
CORRESPONDENCE DEPARTMENT.

**"EYE DEFECTS,"**

A New Book, in cloth, Price, \$1.00.

For terms and important particulars, write to  
**R. H. KNOWLES, M. D.,**  
36 John Street, New York.

**W. C. A. WESTPHAL,**

WATCHMAKER,

41 Maiden Lane, NEW YORK.

Established 1892. Telephone, 3684 Cortlandt.  
Estimates, Repairing, Adjusting of Chronometers, all  
Complicated Watches and Fine Time Pieces.

**DEMAGNETIZING.**

Watches made Non-Magnetic.  
Fine Wheel and Pinion Cutting

**DEITSCH BROS.,**

14 East 17th St.,  
New York.

LEATHER, SHELL,  
EBONY, IVORY.

**JACOT & SON, IMPORTERS,**

**STELLA AND  
IDEAL  
MUSIC BOXES.**

39 UNION SQUARE, - N. Y.

DON'T FORGET THE JEWELERS' CIRCULAR PUBLISHING CO.'S BOOK LIST when in want of any technical work in the Jewelry or Kindred Trades.

**"By Using Our Goods Your Goods Will Sell."**

**We Always Lead**

With Something New and Artistic for Manufacturing  
Jewelers.

**OUR FINDINGS SPEAK FOR THEMSELVES**

Call or Send for Samples of

**OUR LATEST**

**And Keep Your Trade Guessing What You Will  
Show Them Next.**

We are now showing a handsome and complete line of

**MEDALLIONS AND EBONY MOUNTS.**

**HEIMBERGER & LIND,**

158 PINE ST., METCALF BUILDING, PROVIDENCE, R. I.

**Our Hand-made Cases**

are constructed in the old reliable way, which is a pride to  
the Manufacturer, Dealer and Wearer.

STAMPED.



ALL CASES BEARING THIS MARK,  
ARE HAND-MADE.

STAMPED.



Manufactured by **DUBOIS WATCH CASE CO.,**

Makers of **SOLID GOLD CASES.**

21 and 23 Maiden Lane, New York.



**Plated Seamless Wire  
and Aluminum Solder.**

144 PINE ST., PROVIDENCE, R. I.

# CHAS. F. WOOD & CO., DIAMONDS

1 MAIDEN LANE, NEW YORK.

IMPORTERS AND CUTTERS.

## DIAMONDS.

LARGE ASSORTMENTS.

DESIRABLE SIZES.

ATTRACTIVE PRICES.

**R., L. & M. FRIEDLANDER,**

**30 MAIDEN LANE, N. Y.**

97 HATTON GARDEN, LONDON.

## HALL CLOCKS,



*Mantel Clocks,  
Traveling  
Clocks,  
Clock Sets,  
Regulators,  
Bronzes,  
Vases, Ivory  
Miniatures  
and Art Goods.*

Fall Line Now Ready.

**Harris & Harrington,**

32 and 34 VESEY ST., NEW YORK.

Sole Agents to the Trade for J. J. Elliott & Co., London.

## HOROLOGICAL DEPARTMENT,

BRADLEY POLYTECHNIC INSTITUTE,

PEORIA, ILLINOIS.

Largest and best watch school in America. We teach Watch Work, Jewelry, Engraving, Clock Work, Optics. (Formerly Parsons' Horological Institute.) Catalogue Free.

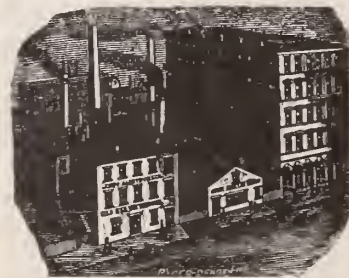

## 37 YEARS OF HONEST RETURNS

IS OUR GUARANTEE OF SATISFACTION TO ALL OUR CUSTOMERS.

WE DO OUR OWN SMELTING,

**JOHN AUSTIN & SON,**

ASSAYERS, REFINERS AND SMELTERS,

74 & 76 Clifford St., Providence, R.I.

## BEER STEINS,

For Prizes, Club Use and Home Decoration.

75 Cents to \$4.50 Each.

**L. W. LEVY & CO.,**

Novelties and Optical Goods,

194 BROADWAY, NEW YORK.

Successors to Levy, Dreyfus & Co.

## TO BLOW EFFECTIVELY IS AN ART

which we never practice personally; but we have invented a machine which does it for us, called the

"Reichhelm Pressure Blower."

This, with Gas Furnaces and Jewelers' Tools generally, is the stock in trade of

**E. P. REICHHELM & CO.,**

23 JOHN STREET, NEW YORK CITY.



GOLD AND SILVER PENCILS, PENHOLDERS, &c.



**FAIRCHILD & JOHNSON CO.**

Office and Factory,  
220 FOURTH AVENUE, N. Y.

## Satisfaction

AND....

## Promptness

is the secret of our success. Our chief aim has always been to render prompt returns and to give satisfaction to all our customers.

**CONLEY & STRAIGHT,**

GOLD AND SILVER

REFINERS, ASSAYERS and SMELTERS,

236 Eddy Street, PROVIDENCE, R. I.

## Horseshoe, Clover, Heart, Wishbone and Anchor.

THESE ARE A FEW OF THE THOUSAND DIFFERENT DESIGNS OF LUCKY BANGLES.

**S. & B. LEDERER CO.**

FACTORY: 100 STEWART STREET, PROVIDENCE, R. I.

New York Office, 11 John Street.

Chicago Office, 131 Wabash Avenue.

**EMPIRE COMBS.**

**SIDE COMBS.**

GOLD AND JEWELED ORNAMENTED.

SPECIALTIES IN ROMAN WORK.

**DAY, CLARK & Co.,**

MAKERS OF FINE JEWELRY,

23 MAIDEN LANE, N. Y.

**PROV. STOCK CO., Chains**

HIGH GRADE ROLLED PLATE

BRACELETS, LORGNETTES.

**10K. GOLD**

Scarf Pins, Brooches,  
Neck Chains, Lorgnettes,  
Bracelets.

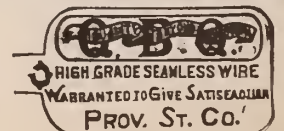

40 Stewart St., PROV., R. I. 11 John St., N. Y. Silvermth' Bldg., CHICAGO.

IMPORTERS AND CUTTERS OF **Diamonds** 65 Nassau St. NEW YORK.  
**Arnstein Bros. & Co.**

**DIAMONDS** and Cutters. **L. & M. KAHN & CO.,** 172 Broadway, **DIAMONDS**  
 Cor. Maiden Lane, N. Y.

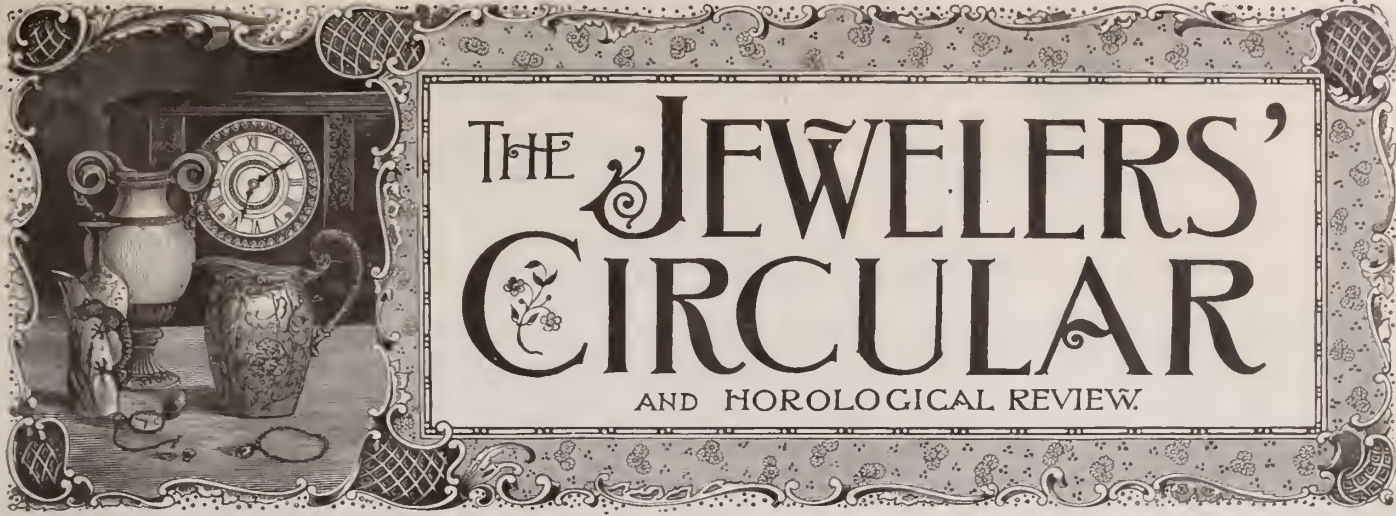

# THE JEWELERS' CIRCULAR

AND HOROLOGICAL REVIEW.

Corbin Building, 11 John St., Corner Broadway, New York.

Copyrighted by THE JEWELERS' CIRCULAR PUB. CO.

Entered at the Post Office in N. Y. as second-class matter.

VOL. XXXIX.

NEW YORK, WEDNESDAY, DECEMBER 20, 1899.

No. 21.

## UNIQUE PRESENTATION TO THE QUEEN OF ENGLAND.

THE Queen of England only upon rare occasions performs functions which call for gifts. When a sovereign has passed her 80th year it is only reasonable to think that each public ceremonial may be the last one in which she will take part. The opening of the Bristol Jubilee Convalescent Home, at Bristol, England, took place on Nov. 15. The electric button illustrated here, from a photograph supplied specially to THE CIRCULAR, caused the doors to fly open upon a touch by her Majesty. It is made in the form of a paper weight, and consists of 18-karat gold. The center—the push-button—is a single brilliant surrounded by rubies in the form of a Tudor rose. The Royal crown, the miniature view of the Home, and other parts are beautifully enameled in colors. The upper part shows the city arms. The length of the whole is about 5 inches. A casket containing an address from the Mayor and Corporation of Bristol was also given to her Majesty. It will be published in the next issue of THE CIRCULAR.

### Falsified Diamonds.

DURING the last few years it has been repeatedly at-

tempted to increase the value of yellow Cape diamonds 25 to 30 per cent, by trans-

forming them into white diamonds. It was reported from Belgium that the experiment had been successful and that a large law suit was expected. Meanwhile chemical science has taken hold of the matter, and, as regards the results obtained, Henri de Parville makes the following report:

The chemist Gilon has investigated whether it is possible to falsify diamonds, i.e., to alter their color. It is thought that the diamond is inaccessible to dyeing agents; but there may be doubts as to this point. According to the physical principle of complementary colors, whereby white can be obtained from violet and yellow, Gilon prepared a solution of alcohol and aniline-violet, and thinking that a binding agent was necessary, he added a few grammes of benzoïn gum. Into this liquid he dipped a yellow diamond, leaving it therein for about one-quarter hour. When he removed it it was white, but had lost all fire. Gilon renewed the experiment with a stronger aniline solution, immersing the diamond only a few seconds. When taken out it was perfectly white and sparkled with its former magnificence. Some weeks after the stone had lost none of its former



ELECTRIC BUTTON OF GOLD, GEMS AND ENAMEL—NEARLY FULL SIZE.

# Our New Lines For The Spring Trade

will be ready right after Christmas, and as we are sparing no effort or expense to bring them to perfection they will be lines not surpassed by any on the market during the season. The quality will be up to our usual high standard of rolled-gold plate, while the finish is the finest that can be produced.

LOCKETS, CHARMS, BRACELETS, CHAINS, PINS, EARRINGS, SILK VEST CHAINS and HAIR CHAIN MOUNTINGS; also a large variety of those dainty little BROOCHES now in vogue, and an enlarged line of BUCKLES.

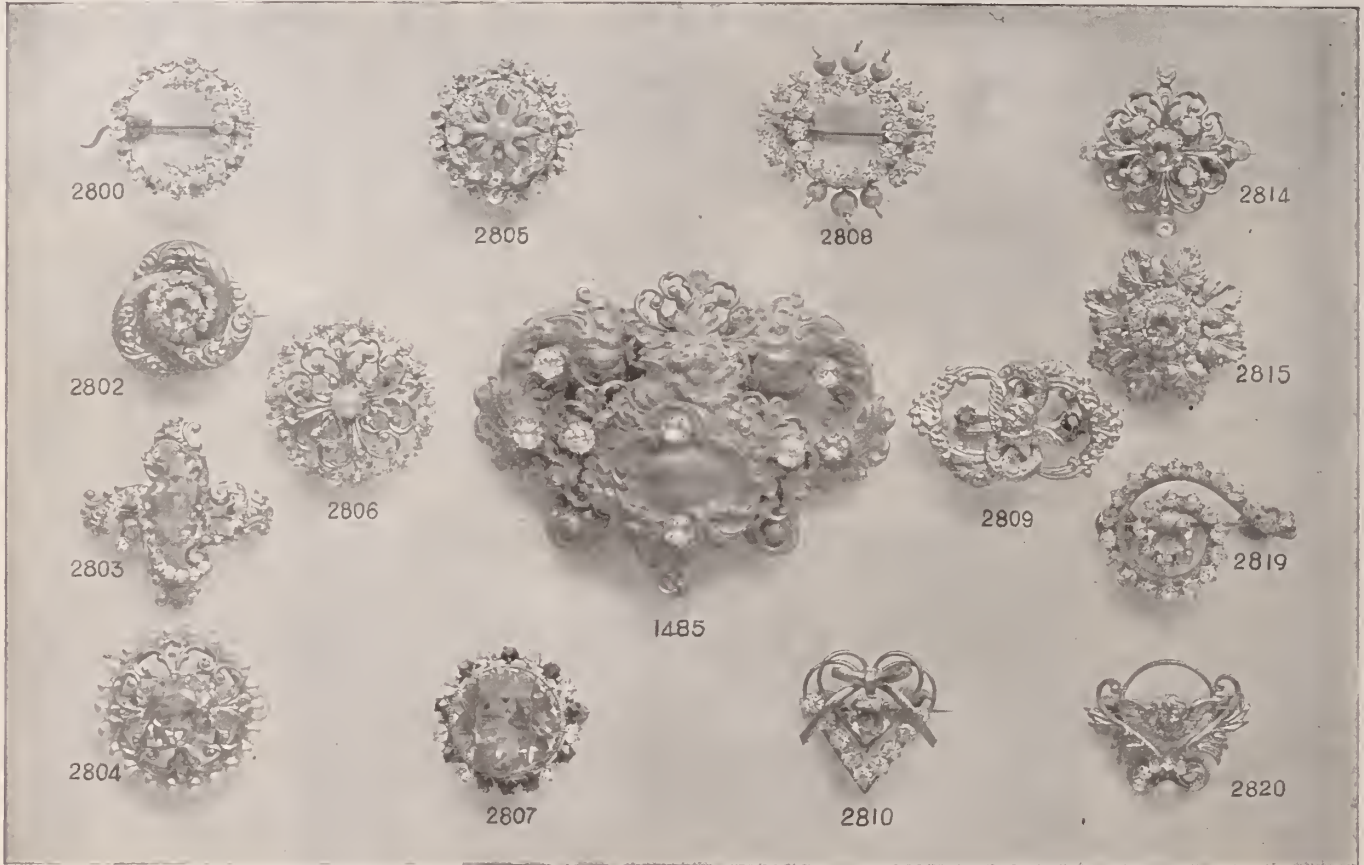

Do not allow your stock of STERLING SILVER TOILET and MANICURE GOODS and NOVELTIES to get too low, as you will have a good demand for them all through the Holiday Season.

OUR CATALOGUE IS YOURS FOR THE ASKING.

**THEODORE W. FOSTER & BRO. CO.,** 100 RICHMOND ST., PROVIDENCE, R. I.  
Successors to FOSTER & BAILEY.

Established 1879. Manufacturer of

**LOUIS W. HRABA,** Fine Leather Goods

29 East 19th St., New York. Exclusively for the Jewelry Trade.

**THE BASSETT JEWELRY CO.,**  
Fine Gold-Filled Chains,  
Lockets and Gold Jewelry,  
PROVIDENCE, R. I.

WATCHES OF PRECISION.

## MATHEY BROS., MATHEZ & CO.,

WATCHES DEMAGNETIZED.



MANUFACTURERS AND IMPORTERS OF

Superior Plain and Complicated

### WATCHES AND MOVEMENTS.

Small Lever Watches a Specialty.



10 SIZE MOVEMENTS.

BRASSUS, SWITZERLAND.

21 & 23 MAIDEN LANE, N. Y.

10 SIZE SPLITS.

# Seasonable Goods, Real Values.



No. 1.

SOLID OAK, PLAIN TOP, WATCHMAKERS' WORK BENCHES, without castors, made of well-seasoned Oak lumber and put together by people who know how.

1st QUALITY, \$9.00 NET.

2d " 8.00 " SOLID OAK.

Size: Length, 40 in.  
Height, 40 "  
Width, 20 "

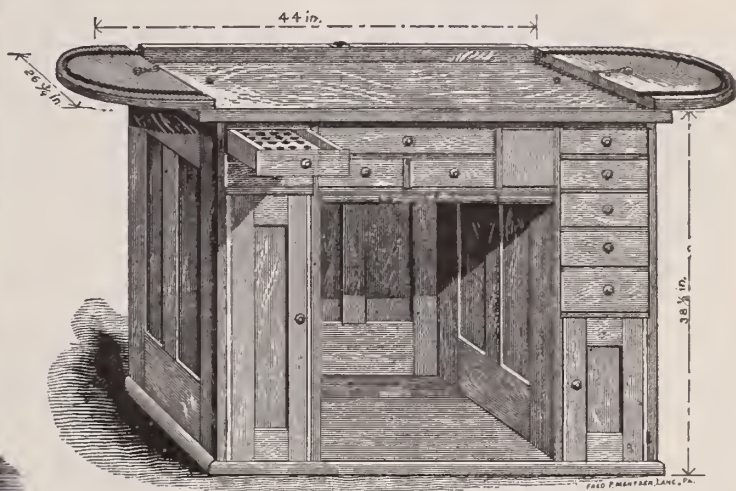

No. 2.

OUR ROLL-TOP SOLID OAK BENCHES are made of the same material as the plain tops, have curtain tops, 10 drawers, apron, chalk hole, lock automatically and are on castors.

PRICE, \$14.00, NET CASH.

Size: Length, 44 in.  
Height, 40 "  
Width, 26 3/4 in.

## Double-End and Single-End Gravers and Liners.

Our GRAVERS have been imitated, in part, as to style only. The quality of our gravers stands the use better than any other graver made to-day.

If your jobber does not have them, insist on getting them, and take no other, or send to us, where your wants will be filled with dispatch.

# L. C. REISNER & CO.

Manufacturing Jobbers, Importers and Exporters,  
Watch Materials, Tools and Supplies,

Jewelry Repairers for the Trade.

LANCASTER, PA.

# "OMEGA" WATCHES.

NONE BETTER MADE. OVER 1,000,000 IN USE.



Pendant Set. 12, 14 and 16 Size.  
Made in Gun Metal, Silver, Gold-Filled  
and Solid Gold Cases.

Send for Price-List.

Our 10 Ligne O. F. "Omegas," full Jeweled Anchor Movements, in 14 K., plain polished or enameled cases, are "just the thing" for the Holiday trade.

Our 12 Size "Omegas," made in 7 and 15 Jewel grades, and Our 16 Size "Omegas," made in 6 different grades—7 Jewels to 21 Jewels—are particularly desirable where fine timepieces are desired.

The "Omegas" are sold only to the regular trade, so no prices will be found in any publication whatever, thereby insuring a good profit.

**Edmond E. Robert, 3 Maiden Lane, N. Y.;**

**Cross & Beguelin, 17 Maiden Lane, N. Y.,**

**SOLE SELLING AGENTS.**

## Of Greatest Importance

to the live manufacturing Jeweler is a careful consideration of our lines of Jewelers' Findings.

NEW ASSORTMENTS OF

**Buckles, Galleries, Brooches,  
Settings, Pins, Etc.**

**THOS. W. LIND,**

MANUFACTURER OF JEWELERS' FINDINGS,

67 FRIENDSHIP STREET,

PROVIDENCE, R. I.



# The Last Shall be First.

# 1900

All conditions indicate that the last year of the century will be the best and most prosperous one. The retail jeweler can assure this beyond peradventure if he will carry in stock a complete line of

## The Standard Simmons Chains.

They are the best chains of the century, the acme of the chain-maker's art, and the 1900 line is better than ever. The same can be said of our

**CYRANO CHAINS, LOCKETS, SEALS AND  
MARLOWE BRACELETS.**

---

...AT JOBBERS...

---

# R. F. SIMMONS & CO.

Factory and Main Office:

New York Salesroom:  
9-13 MAIDEN LANE.

ATTLEBORO, MASS.

---

SALESMEN FOR 1900.

Western Representative, LOUIS E. FAY.

Eastern Representative, GEORGE L. SWEET.

New York Representative, JOHN DRAKE.



No. 257.



No. 258.



No. 1000.

**ALMOND DISHES**  
 SOMETHING FOR YOUR  
 HOLIDAY TRADE  
 THESE DISHES ARE OF GOOD  
 WEIGHT AND THE PRICES  
 AT WHICH WE ARE SELLING  
 THEM PERMIT OF THEIR  
 BEING USED AS LEADERS  
 BON · BON · DISH  
 TO MATCH ··· WRITE  
 FOR PRICES  
 ILLUSTRATIONS  
 FULL SIZE



**R. WALLACE**  
 & SONS MFG. CO.  
 SILVERSMITHS  
 WALLINGFORD · CT.  
 BRANCHES  
 226 · 5<sup>TH</sup> · AVE · NEW · YORK  
 109 · WABASH · AVE · CHICAGO  
 120 · SUTTER · ST · SAN · FRANCISCO

whiteness and fire, and Gilon does not doubt that it will retain these qualities for a long time yet. Hence it is proven that a falsification is possible. When viewing the falsified stone under a microscope not the slightest stratification nor the least dimness on the facets is visible. Rubbing with camel's hair or linen does not affect the coloring. It was formerly believed that it would be sufficient to dip the sophisticated diamond into alcohol to restore its yellow color. As a matter of fact, this is often successful, but Gilon has rendered the coloring so solid that even an alcohol bath does not affect the doctored stone. So there is no way of recognizing the adulteration? Yes there is, concludes the *Journal der Goldschmiedekunst*; Gilon has found this as well. Dip the suspected stone for a few seconds in aqua fortis. If really falsified, its yellow color will reappear at once.

### Louis XV. Clock Brings \$6,400.

[New York Herald, Dec. 6.]

AT the sale of the Gazelin collection a remarkable Louis XV. clock, which brought 21,000 francs at the Double sale in 1881, realized 32,000 francs.

A clock with Dresden figures fetched 2,850 francs, three gilt-bronze candelabra with Dresden figures 3,500, a pair of scent-burners in bronze and Dresden 1,520, a Dresden porringer 1,500, a group of three Dresden figures 4,150, a Dresden shepherd and shepherdess 2,000, a pair of Chinese children in Dresden 3,000, and a statue of Time in Dresden china 1,400.

Miss Lillian Pauncefote has a most beautiful engagement ring. Two large, heart shaped sapphires are set side by side and capped by a true love knot in diamonds. The whole is set in platinum, sprinkled with tiny brilliants.

Ivory tusk cups and vases with silver mountings appeal to the artistic sense.

### CHRISTMASTIDE NOVELTIES.

#### A LADY'S RAMBLES AMONG THE JEWELERS.

In the jewelers' shops the glowing color and flashing light of gems, the glitter of gold and the soft sheen of silver combine to create a fairyland of delight to the Christmas shopper. Many women, wise in their experience, plan to do most of their Christmas buying therein, even when this is to be carried out upon a modest scale. For the small wares of to-day, in personal ornaments, silver or leather goods, are designed and executed with the same care and skill which are bestowed upon more pretentious objects, and one may make purchases of any of them with the comfortable assurance of securing something of intrinsic worth and beauty, whether the price be marked in cents or dollars. And, as a matter of fact, the variety in a list of trifles ranking in the former category would be a complete surprise to the uninitiated shopper.

It is noticeable that in the attractions provided for the holidays masculine wants and pleasures are quite as skilfully catered to as those of my lady fair. For instance, what cleverness marks the new smoker's cabinet, which is veritable treasure-trove, not only for the persons for whose special delectation it was designed, but also for the dainty housewife who seeks a remedy for the trail of ashes and burnt matches that is too often over all. This is a handsome, gilt-bronze box lined with cedar. Lifting the lid, a tray containing receptacles for ashes and matches and a match scratcher is disclosed. The peculiar point of interest is in this tray. Contrary to custom, it does not lift out, but, being pivoted to the box, at a touch it swings upward to the perpendicular. The ash and match receivers maintain their equilibrium and their contents, because they are hung in the tray after the fashion of the cars in a Ferris wheel. The colored decoration of the lid is of striking character and appertains to racing, golfing and other sports.

For men the double vest chain is decidedly in favor and there is promised among the ultra-fashionable an epidemic of a fad of the eighteenth century, when the "swell" of the day sported a cane, a sword, rings, snuff-box and "two watches." It is supposable that one of these watches will continue to be a plain, accurate, every day timepiece, while the other may represent any of the rich, rare or curious affairs which ingenious makers delight in contriving. Gold and platinum continue fashionable in chains, while some shades of gold introduce a glint of red or russet that is very effective.

English briar pipes are inlaid with silver or carved and banded with gold or silver. Meerscham and amber show mounting of silver or gold in various degrees of elaboration. Appropriate accompaniments for a pipe are cleaners, folding spoon, packer, pick, etc.

Match boxes for the vest pocket vary little except in finish and decoration. The frame inside for a picture remains popular.

Flat topped gold sleeve links with a handsomely engraved monogram will be recognized as quite the correct thing by a conservative dresser. In scarf pins the pearl is always safe, but oftener something handsome, odd or unique is preferred.

The turquoise is hardly a man's stone, yet it is occasionally introduced into rings, and being the stone for December, is very appropriate for a combined birthday and Christmas gift.

Heads of nearly every animal that can be manipulated to the purpose serve as ornaments for umbrella handles. They are carried out in carved crystal, ivory and ebony, etc. Stag horn is much used and iridescent pearl seems to have taken on new life in connection with silver and silver-gilt. Serpents twisted somewhat into the shape of a shepherd's crook are attractive in small light handles. A dragon's

# THE APOLLO

WARRANTS THE EPITHET "POPULAR,"

as shown by sales from Maine to Oregon.

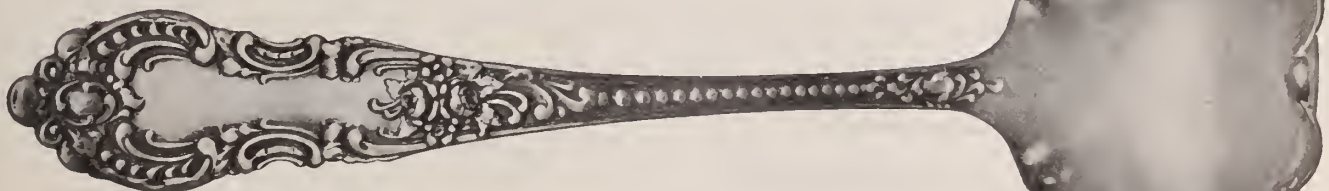

Made by J. B. & S. M. KNOWLES CO.,  
PROVIDENCE, R. I.

Established 1852.

STERLING SILVER ONLY.



**DIAMONDS.**  
**Wm. S. Hedges & Co.,**  
 IMPORTERS OF  
**Diamonds and Precious Stones.**  
**DIAMOND JEWELRY.**  
**170 Broadway, New York.**  
 26 Holborn Viaduct, London.

*Oppenheimer Bros. & Veith,*

*Importers and Cutters of*

*Diamonds*

*Dealers in*

*Watches,*

*Cor. Nassau and John Streets,*  
 (PRESCOTT BUILDING.)

*...New York...*

*Amsterdam,*  
*2 Tulp Straat.*

*London,*  
*45 Holborn Viaduct.*

**MOUNT & WOODHULL,** FORMERLY WITH LATE FIRM OF  
 RANDEL, BAREMORE & BILLINGS,  
 . . . . IMPORTERS OF . . . .  
**Diamonds, Other Precious Stones, Pearls, Etc.,**  
**Makers of fine DIAMOND JEWELRY,**

26 MAIDEN LANE (SOUTHWEST CORNER), NEW YORK.  
 NASSAU STREET

JOHN C. MOUNT.

ADDISON W. WOODHULL.

RUBIES.

SAPPHIRES.

**C. G. MALLIET & CO.,**

EMERALDS.

14 MAIDEN LANE, N. Y.

DIAMONDS.

## The Bowden Rings

ARE COMPLETE IN VARIETY, CORRECT  
 IN QUALITY AND PERFECT IN FINISH.  
 WE MAKE EVERY VARIETY OF FINGER  
 RINGS

**J. B. BOWDEN & Co.,**

1 MAIDEN LANE,

NEW YORK.

head in oxidized silver forms a handsome handle for a man's umbrella. Goli has contributed its inspiration to the tale of handles. A cut crystal ball is a daring but successful appeal to feminine taste. Carved tortoise shell, enamel on silver, Dresden china and jeweled gun metal represent other pleasing fashions.

Some of the prettiest long chains for women are in plain gold with very fine links and distinguished only by daintiness and originality of pattern. These measure from 42 to 48 inches.

Enameled flower pins bloom again in their perennial popularity. Violets, single or double; pansies, marguerites, wild roses and four leaved clover all tempt the feminine shopper.

Carved ivory, crystal and jade are all greatly in evidence in bric-à-brac.

There is a strong fad for Dutch silver in objects of art and in table ware.

Martelé work remains the last word in silver and its field extends from cases for jewels, hollow ware for the table, magnificent vases and other decorative objects to cigarette and match boxes and tiny bonbonieres.

Flower bowls, with their latticed tops, come in exquisite china and ornamental silver.

A magnificent diamond corsage ornament represents a spray of wild rose—leaves, blossom and birds. The flower is effectively mounted on a vibrator, a style increasingly noted in finest jewelry.

A plate to beguile a child into learning its letters is of Delft with the alphabet in raised characters forming the border, and in the center a sleek pussy cat complacently lapping cream from a bowl.

ELSIE BEE.

**Artistic Gold Mounted Gavel Presented to Speaker Henderson.**

WASHINGTON, D. C., Dec. 7.—Speaker Henderson will be reminded, all through his work as Speaker of the House, of the kindly regard with which he is held, especially by the citizenship of Iowa, through the medium of a gavel which has been presented to him. The wood of which the handle is composed is from the State of Iowa, but that of which the mallet is made was brought from the Spanish flagship *Reina Maria Christina*, sunk by Dewey in Manila Bay. The gavel is ornamented by three solid gold plates, one bearing the coat of arms of the United States, another those of Iowa, and still another Mr. Henderson's monogram; on either end, on gold flanges, are representations of agriculture, commerce and the thrift of Iowa; on the handle are other plates bearing the wild rose, as the emblem of Iowa, and around the ferrule run ears of corn, also in gold. The handle is also ornamented with 45 golden stars, representative of the States of the Union. Steven C. Wilcox, a veteran of the civil war, did the engraving, while Frank Schiampp prepared the gold. Both gentlemen belong to Des Moines.

**Precious Stones: London Market.**

HATTON GARDEN, London, Eng.,  
December 9, 1899.

Contrary to expectations no further rise in rough was announced on Monday. Definite statements are made in the London jewelry journals to the effect that the Syndicate has signed a new contract to come into effect at the close of the current one (next April) at an advance of 25 per cent. I have received no confirmation of the rumor. The present contract was not signed until the end of 1898 or early in 1899.

The Boer paper, *The Standard and Diggers' News*, published in the Transvaal, states that a dispatch from Mr. Rhodes has been intercepted declaring that the DeBeers Company's mines are filling with water owing to lack of coal to work the pumping machinery. The damages are estimated at £10,000 a day. The journal referred to has always been antagonistic to the DeBeers Company. Many rumors have been current as to damage to the mines by the bombardment, which have lacked confirmation. On the other hand there is reliable information as to minor difficulties; many of the employes are on permanent military duty and others are engaged in making shells. It would be absurd to suppose that under the circumstances production can be carried on. The expression that the mines were "practically closed" appeared in an authoritative cable a few weeks ago. The town has been besieged for six or seven weeks.

There is very little talk of anything but diamonds. Pearls and emeralds are still in good demand, but no other specialties are mentioned. Trade will quiet down towards the Xmas holidays, but business has been very fair for some weeks. The shopkeepers will now have their innings.

R. F.

**The Estate of the Late Reinhold Siedle.**

PITTSBURGH, Pa., Dec. 16.—The will of Reinhold Siedle was filed for probate on Monday, Dec. 11. It disposes of an estate of \$65,000, of which \$15,000 is in real estate. The executor, Robert T. Reineman, is directed to have the testator's interest in the firm appraised and give his sons, William R. and Otto C. Siedle, an opportunity for purchasing it. If they refuse to buy, then the interest is to be sold at auction, public or private, to the highest bidder. If they buy the interest, they shall pay \$10,000 at once, and the remainder in 10 equal payments with interest within five years. The two sons, W. R. and O. C., receive \$5,000 each. The reason that they receive larger shares than their brothers is that they had been "dutiful" and have assisted in the business.

H. M. Woodruff, jeweler, Kennebunkport, Me., and his family are Winter visitors at Winter Park, Fla.

Greenleaf & Crosby Co., Jacksonville, Fla., issued invitations to their holiday opening of holiday goods, Dec. 11, held from 10 o'clock A. M. to 9 o'clock P. M.

ESTABLISHED 1840.

**Chester Billings & Son,**

Successors to **RANDEL, BAREMORE & BILLINGS,**  
IMPORTERS OF

1840 RANDEL & BAREMORE.  
1866 RANDEL, BAREMORE & CO.  
1880 RANDEL, BAREMORE & BILLINGS.

**DIAMONDS**

OTHER PRECIOUS STONES AND PEARLS.

58 Nassau Street,  
29 Maiden Lane, 22 Holborn viaduct,  
NEW YORK. LONDON, E. C.

**DIAMOND JEWELRY.**

...ESTABLISHED 1841...

A. CARTER. C. E. HASTINGS. G. R. HOWE. W. T. CARTER. W. T. GOUGH.

**Carter, Hastings & Howe,**

TRADE  MARK.

MANUFACTURERS OF

**Gold Jewelry,**

9, 11, 13 MAIDEN LANE, NEW YORK.

FACTORY, NEWARK, N. J.

**Pearls** \_\_\_\_\_  
**Opals**

Importers and Cutters **GOODFRIEND BROS.,** Precious and Imitation Stones

9-13 Maiden Lane, N. Y. 174 Weybosset St., Providence, R. I. 10 Rue Cadet, Paris.

TELEPHONE, 662 CORTLANDT.

**John F. Saunders,** Cutter and Importer of

**DIAMONDS** AND OTHER  
PRECIOUS STONES.

FINE PEARLS A SPECIALTY.

68 Nassau St., cor. John St., Sheldon Building, Room 16, NEW YORK.

## PEARLS—DIAMONDS

### Special Advantages

arise from doing business with "specialists."

We are distinctly "specialists," dealing in but one line of goods.

We are dealers in Pearls and Precious Stones exclusively.

In consequence, most advantageous buying results and the best selections are put before our customers.

### Alfred H. Smith & Co.,

182 Broadway, N. Y.  
CHICAGO. LONDON.

And Other Precious Stones.

# NISSEN

*Ludwig Nissen.*

*Emil Knopf*

18 JOHN ST. NEW YORK

*John W. Ruelker*

We carry the largest, finest and most complete line of Mounted Diamond Jewelry of any house in America.

### Big Fire in a Clock Factory.

Case Manufacturing Shop of the E. N. Welch Mfg. Co. Completely Destroyed by Fire.

BRISTOL, Conn., Dec. 14.—The case manufacturing building of the E. N. Welch Mfg. Co., clock manufacturers, Forestville, known as the J. C. Brown shop, was totally destroyed by fire to-night, causing a loss of \$60,000; insurance, between \$45,000 and \$50,000. The building destroyed was of wood and brick, 225 feet long, 48 feet wide and four stories high. It was in the rear of a group of four other buildings, all of which were damaged, but the loss to the other buildings will be comparatively light. The burned building was filled with clock cases in all stages of construction and much material. The cause of the fire is unknown, but it is supposed to have originated in the boiler room adjoining the main building. The movement shop was destroyed last April, entailing a loss of \$60,000, but a new shop has just been completed. The last fire will necessitate a suspension of business until a new factory can be built, and, though it is planned to erect a new brick factory as rapidly as possible, it will be several months before operations can be again resumed. More than 300 hands are thrown out of employment.

The blaze was discovered at 8.05 o'clock in the vicinity of the boiler room, but in a few minutes, owing to the inflammable nature of the contents, the building was ablaze on every floor and from end to end. There were 175 hands employed in the burned building.

### \$20,000 Worth of Seized Diamonds to Be Sold at Auction.

DETROIT, Mich., Dec. 15.—Twenty thousand dollars' worth of diamonds will shortly be sold at auction by the United States authorities here in the Federal building. The date of the sale will be announced later and it is expected that diamond dealers from all over the country will be present. These stones, 581 in number, were seized by the authorities from Louis Bush, who was arrested here some time ago by special customs officer Chas. E. Lewis, who followed Bush across the border from Canada and landed him in jail. Bush was afterwards released on \$5,000 bail furnished by William P. Holiday.

To make the sale of the gems possible, Judge Swan entered an order forfeiting them to the Government, as no claim or answer had been filed within the time given to Bush. It is thought that he is at present in New York. The stones are in 11 packages and it is the intention to sell them by the package instead of singly. However, if diamond dealers do not come in as large numbers as expected, Detroiters may have a chance to buy a few.

Mr. Ogden, late of the Portland Optical Co., has purchased Chandler's jewelry business, 431 Congress St., Portland, Me.

F. L. Reams, in charge of the Mrs. A. Shibley jewelry store, Wooster, O., has been united in marriage to Miss Emily Marquis, of Zanesville, O.

**The Department Store.**

**John Wanamaker Testifies Before the Industrial Commission.**

WASHINGTON, D. C., Dec. 9.—Among the many prominent merchants, manufacturers, corporation representatives and others who have appeared before the Industrial Commission to give evidence during its present session no one has attracted more attention than John Wanamaker, who to-day testified upon the subject of department stores. This interest was partly due to his financial standing, partly to the very large department store interests in which he is at present deeply engaged; and perhaps more still on account of his many years of department store experience. Contrary to the opinion held by the public in general and the smaller retail merchant in particular, he claims that the department store is beneficial to society and that it is the natural result of existing conditions. Speaking of the question in its general outlines he said:

"It is a natural product evolved from conditions that exist as a result of fixed trade laws. Cheaper capital, better transportation and more rapid communication make the modern retail store possible, natural and useful; therefore inevitable. Executive capacity combined with the command of capital finds opportunity in these conditions, which are in harmony with the irresistible determination of the producer to meet the consumer directly, and of merchandise to find distribution along the lines of least resistance. Economy in the expenditure of money, time and effort measures department store success. Just in proportion as these ends are reached is it popular, powerful and prosperous."

In confirmation of the assertion that the user gets the benefit of reduced prices on account of the system of department stores Mr. Wanamaker called attention to many instances in which this was the case, from his point of view. Among the articles named were the standard patterns of French China dinner ware and cut glass, which he claims are now retailed at 25 per cent less than they were 10 years ago, the reduction to be credited entirely to the influence of the modern retail store.

When asked the percentage of profit that was made by the keeper of the store

department store Mr. Wanamaker stated it to be his opinion that it did not exceed from three to six per cent.

So far as throwing people out of employment and business was concerned, Mr. Wanamaker claims that the department store has not only reduced prices, but that the immediate result has been an increased consumption and employment, more labor being required for production, transportation and distribution; although he could not deny the assertion that the introduction of the large retail store had conspired to drive the smaller merchant out of business. But in this connection he took up the well worn assertion that the interests of the few people thus concerned were not to be compared with the interests of the masses of the people who were benefited.

Wages are claimed to be better under the department store system than they are in the case of smaller merchants, and it was claimed that the manufacturer was able to make more profit under the present method of direct sale to the merchant than he could when everything was bought through the wholesaler. It was claimed that in large stores the purchaser of large quantities did not have any advantage over the small one. He also stated that the mail order business had not been found to be profitable in so far as his own experience was concerned. He also favors the employment of women in business houses, and states that he has known instances where they are paid as high as \$5,000 per year.

Referring to the question of trusts, he expressed himself as of the opinion that the number and variety of articles offered for sale in a department store are so varied that it would be almost impossible to form a combination. He also expressed himself as of the opinion that there should be some law enacted that would be restrictive of the power of trusts.

The hearing was a lengthy one, but as a conclusion Mr. Wanamaker stated it as his opinion that there is no cause for the present warfare on the department store.

Mr. Duell, who has been engaged in the jewelry business in Garden City, Mo., for some time, is reported to have failed.

George Lerew, jeweler, Hamburg, Ia., has purchased a store building located diagonally across the corner from his old stand and moved into it.

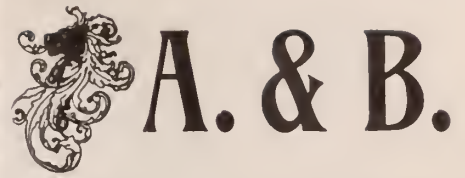

**A. & B.**  
**HEADQUARTERS**

FOR

**Waltham Watches**

EVERY GRADE.

**AVERY & BROWN,**

68 Nassau St., New York.

OTTO K. TREIBS.

PAUL E. TREIBS.

**TREIBS BROS.,**

68 Nassau St.,

New York.

139 Mathewson St.,  
Providence, R. I.

CUTTERS AND IMPORTERS OF

**Opals.**

**F. E. TREIBS,**

Oberstein,

Germany.

ESTABLISHED 1842.

HERMANN TREIBS.

ALBERT TREIBS.

EMIL TREIBS.

**CASH OFFERS.**

If at any time you have offered to you by your customers any Jewelry containing diamonds, pearls or other precious stones, and you do not care to buy them yourself, send them to us and we will submit an IMMEDIATE CASH OFFER. Trade and Bank References if desired. Established 1880. Correspondence solicited.

CHARLES S. CROSSMAN & CO.,  
3 Maiden Lane, New York.

CATSEYES | SAPPHIRES | DIAMONDS | RUBIES | EMERALDS | PEARLS | PEARL NECKS | PEARL ROPES

OLIVINES  
OPALS  
SCIENTIFIC RUBIES

Pearl Collarettes, mounted with Diamond Bars.

**PEARLS, DRILLED AND UNDRILLED.**

**PEARL ROPES, NECKS and COLLARETTES.**

**We are buyers of American Pearls.**

LONDON: **JOSEPH FRANKEL'S SONS,** 68 Nassau Street,  
19-20 Holborn Viaduct. NEW YORK.

TELEPHONE, 3899 CORTLANDT.

FANCY COLORED DIAMONDS and GEMS in PEARLS and PRECIOUS STONES.

**Hery Charged with Being a Good Imitator of a Pennyweighter.**

WILLIAMSPORT, Pa., Dec. 14.—A man giving his name as M. Hery and claiming Chicago as his home was arrested here Tuesday evening, on the charge of having stolen a diamond ring from Huston Jackson's jewelry store, Elliot block. Hery is an agent for Johnson & Tomek, 103 and 105 N. Lincoln St., Chicago, and handles a line of mouldings. He arrived in the city Tuesday afternoon and registered at the Updegraff. About 4:30 in the afternoon he called at Mr. Jackson's store. He asked Mr. Jackson to let him look at some diamond rings to the value of \$10 or \$15. A trayful was shown him. He did not like the rings and wanted to see higher priced goods. They were shown to him. He appeared to be a connoisseur in diamonds and Mr. Jackson placed a jeweler's eye glass at his disposal. He picked up several rings at a time and turning his back to the case examined them critically, finally placing the rings back in the tray. Mr. Jackson noticed that the tray compartments were filled, a condition in which he keeps them. Hery picked upon a particularly fine ring and said he would be around in the morning. If the ring proved to be as good in daylight as it appeared then he would take it. He departed.

After supper Mr. Jackson had occasion to place the tray on the case again. He immediately discovered that a ring worth about \$10 occupied the place of a \$35 ring. The Chief of Police was called in and was given a description of Hery. The Chief visited a number of jewelry stores and

while at Kolb Brothers' place Hery came in. The Chief got a clerk at Sylvester Mussina's jewelry store to identify Hery, the man having been there. The Chief then kept on Hery's trail and followed him around to several jewelry stores. He arrested his man at Pine and W. 4th Sts. Hery was taken to Mr. Jackson's. He pulled out a box containing some rings and from among the number Mr. Jackson picked out the one he had missed. The ring was later identified by Mr. Jackson by private marks. The identification was positive.

At the police department, City Hall, Hery was searched. On him were found \$297 in bills and \$4.40 in silver. He had 10 rings, one of which contained no stone. He had a diamond stud and a gold watch and chain with a \$10 gold piece for a charm. About his person was found Mr. Jackson's jeweler's eye glass. Later at night Mr. Jackson, Mr. Diener, of Diener & Co., and J. B. Dayton made a critical examination of the jewelry. The diamond stud was valued at \$85 and the rings ranged from \$10 to \$125. The latter ring was an exceptionally fine one. Hery's possessions, including money and jewelry, footed up to \$873.40. An attempt had been made to remove some of the private marks on the rings. An excellent description of all the property is in the hands of the police. Hery claims to be a German. He is about 35 years old, 5 feet 8½ inches tall, weighs 160 pounds, has a broad face, high cheek bones, long flat nose; black hair, thin in front and on the crown; brown moustache with ends turned up; large ears extending out from the head.

He wore black enamel shoes, striped pants, black diagonal sack coat, black worsted overcoat, light gray Fedora hat with white band. He was sent to jail today in default of \$500 bail.

Hery's order book showed that he has been doing some business in the moulding line. His itinerary, as shown by his order book, has been as follows: September—12th, Hornellsville; 13th, Salamanca; 16th, Hornellsville, Olean, Wellsville; 18th, Corning, New York. October—23d, Auburn; 25th, Penn Yan; 30th, Owego; 31st, Oneida, New York. November—1st, Rome, Utica; 2d, Little Falls; 3d, Amsterdam; 6th, Cohoes; 8th, Albany, New York; 9th, Pittsfield; 11th, Northampton; 13th, Greenfield; 14th, Clinton, Pittsburgh, Massachusetts; 16th, New London; 21st, New Haven; 23d, Bridgeport, Connecticut; 27th, South Norwalk; 28th, Peekskill; 30th, Kingston, New York. December—4th, Middletown, New York; 9th, Wilkes-Barre; 11th, Plymouth, Bloomsburg; 12th, Scranton, Pittston, Williamsport.

Howard Crawford, an employe of the Knickerbocker Silver Co., Port Jervis, N. Y., had a narrow escape from death last week. He was engaged in his work near some machinery in the factory, when suddenly he was seized by the belting and carried to the shafting near the ceiling. As he arrived at the upper shafting the belt fortunately slipped off the wheel, and Crawford then fell to the floor. Otherwise he would have been carried over the shafting and probably killed. Both bones of his right forearm were broken.

ALVIN L. STRASBURGER.

SOL. KAISER.

Established 1849.

# LOUIS STRASBURGER'S SON & CO.

9-13 MAIDEN LANE, NEW YORK.

## ...DIAMONDS...

PEARLS,

SAPPHIRES,

RUBIES,

EMERALDS,

MARQUIS DIAMONDS.

CHICAGO, ILL., 103 State Street.

PARIS, 25 Boulevard Haussmann.



**Failures in the Diamond Trade of Antwerp.**

WASHINGTON, D. C., Dec. 14.—Consul Hill writes from Amsterdam, Nov. 17, 1899:

"Advices from Brussels state that two failures in the diamond trade have taken place at Antwerp, and that within the next fortnight other suspensions will be announced. On Wednesday evening a concourse of men, estimated at 2,500, without work, marched through the streets of Antwerp. The entire stock of diamonds is said to be exhausted, and by March a rise in price of 100 per cent is predicted. In Amsterdam 2,000 men have been laid off, but no failures are reported."

**Litigation Over Alleged Infringements of Fountain Pen Patents.**

A number of new suits for infringement of patents or for selling infringing goods have recently been instituted by the L. E. Waterman Co. Four bills in equity were recently filed in the United States Circuit Court for the District of Philadelphia against the Parker Pen Co. and Frank Beaston, Joseph Beaston and George Beaston, to enjoin them from making alleged infringements upon an improvement in fountain pens, the patents of which are owned by the Waterman company. Other actions are against Rhodes, Lockwood & Co., proprietors of the Sterling Fountain Pen Co.; H. R. Johnston, Springfield, Mass., for selling Sterling pens; Smith & McDonough, Hartford, Conn., for selling the A. A. Waterman pen; C. M. Parker, New Haven, Conn., for selling the Parker pen; J. C. Parker, Washington, D. C., for selling the Sterling pen; Yale College, New Haven, Conn., for handling the Parker pen.

Testimony to be introduced on the action of the L. E. Waterman Co. against R. H. Macy & Co. was taken last week in the Post Office building, New York. The action in question is now on at the United States Circuit Court, and is to restrain the defendants from selling the "non-leakable pen," which is claimed to contain infringements of Waterman's patents.

Judge Lacombe Dec. 10 denied a motion to restrain the L. E. Waterman Co. from bringing further actions against the customers of the Parker Fountain Pen Co. until the test cases on the patents involved in the suits had been decided. The motion was made Dec. 1 in the suit in the United States Circuit Court brought by the L. E. Waterman Co. against Vassar College.

H. E. Adams, who recently went to Tampa, Fla., from Sanford, Fla., and opened a jewelry store, gave his formal opening Dec. 9. A fine orchestra was in attendance and a throng of people were there during the evening. Mr. Adams is the watch inspector for the Plant System.

**Gifts for Men**



In 14-Karat Gold—ORNAMENTED WITH PRECIOUS STONES—and in Sterling Silver. Goods that appeal to refined people at all times. Made handsomely, heavy and exclusively for the Jewelry trade.

**Woods & Chatellier,**  
Gold and Silversmiths.

860 Broadway, N. Y.  
42-46 Hill St., Newark, N. J.

**Pearl Perfection.**

Perfect in quality, perfect in assortment, our stock of Pearls is one of the largest owned by any house in America.

**Fred. W. Lewis & Co.,**

No. 1 MAIDEN LANE (Cushman Building), NEW YORK.

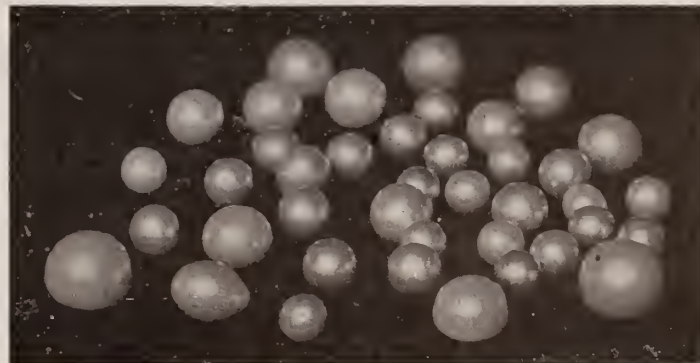

**"The Pearl House."**

We have no salesmen; call or write.

**EISENMANN BROS.,**

PARIS, 3 Rue St. Georges.

21 & 23 MAIDEN LANE, NEW YORK.

**Stern Bros. & Co.,**

Cutters of . . .

MANUFACTURERS OF

**DIAMONDS, Gold Rings and Thimbles,**

68 NASSAU STREET, NEW YORK.

RING FACTORY, 33-43 GOLD STREET, NEW YORK.

DIAMOND-CUTTING WORKS, 142-146 W. 14TH ST., NEW YORK.

LONDON OFFICE, 29 ELY PLACE.

CHICAGO OFFICE, 149 STATE ST.

**JAMES KAHN'S SONS,**

PARIS: 7 RUE CADET.

IMPORTERS AND CUTTERS OF DIAMONDS,

Amsterdam, 2 Tulp Straat.

12, 14 & 16 John St., New York.

**Importations at the Port of New York.**

*Weeks Ended Dec. 16, 1898, and Dec. 15, 1899.*

China, Glass and Earthen Ware:	1898.	1899.
China .....	\$58,059	\$50,228
Earthen ware .....	19,366	13,050
Glass ware .....	13,766	10,764
Optical glass .....	not recorded	1,968
<b>Instruments:</b>		
Musical .....	10,855	13,418
Optical .....	8,438	6,852
Philosophical .....	978	3,417
<b>Jewelry, etc.:</b>		
Jewelry .....	9,009	6,565
Precious stones .....	144,205	158,772
Watches .....	25,845	32,603
<b>Metals, etc.:</b>		
Bronzes .....	3,483	2,914
Cutlery .....	24,802	36,658
Dutch metal .....	4,712	.....
Platina .....	37,508	21,937
Plated ware .....	2,235	.....
Silver ware .....	676	732
<b>Miscellaneous:</b>		
Alabaster ornaments .....	.....	398
Amber .....	1,571	390
Beads .....	2,361	1,344
Clocks .....	1,526	3,153
Fans .....	19,449	17,238
Fancy goods .....	4,669	8,390
Ivory .....	2,300	.....
Ivory, manufactures of.....	665	366
Marble, manufactures of.....	10,124	4,595
Statuary .....	4,863	16,573

**The New President of the E. Jaccard Jewelry Co.**

ST. LOUIS, Mo., Dec. 14.—Eugene R. Cuendet, the subject of this sketch, was born in this city in the '70's. What brings him prominently before the public eye is his recent election as president of the E.



**EUGENE R. CUENDET,**  
NEW PRESIDENT OF E. JACCARD JEWELRY CO.

Jaccard Jewelry Co. When young he was taken to Switzerland and spent three years at school in Lausanne, completing his education in this city. His father, Eugene J. Cuendet, was president of E. Jaccard Jewelry Co., and his mother, before

her marriage, was Miss Lizzie Sells, of a noted local family. Mr. Cuendet, though young and possessed of the cares of an old established and large business, is affable and approachable, and is noted in the community in which he lives for his business push, enterprise and unostentatious liberality.

**Important Regulation in the Dominion Tariff.**

TORONTO, Can., Dec. 15.—Hon. Wm. Patterson, Minister of Customs, recently held a conference in Montreal with the leading importers of that city during which some important points in regard to appraisement were discussed. The chief issues raised were in connection with the iron and steel trade, but the principles adopted by the Government relate equally to other classes of imports. There have been complaints as to a lack of uniformity in appraisement at different ports arising from the fact that goods ordered before the rise in values took place have been valued for duty at current prices in the country of export, instead of at invoice value. The ruling of the Department is that appraisement should be at present values, under the section of the Customs Act, which reads:

"The value for duty should be the fair market value thereof when sold for consumption in the principal markets of the country whence and at the time when the same were exported, etc."

Importers of goods bought before a rise but shipped after the increased price has gone into effect will, therefore, have to pay duty upon a Customs valuation higher than the invoice price. In the case of goods forwarded on commission the amount of commission is to be added to the invoice price in fixing the value for duty.

**Dishonest Bookkeeper of Grafner Bros. in Jail.**

PITTSBURGH, Pa., Dec. 16.—The trade of this city were treated to another sensation this week in the disappearance of Grafner Bros.' bookkeeper, Benjamin Lewis. He did the banking for his employers as usual on Monday afternoon, but failed to return. The firm, growing alarmed at his absence, telephoned the Second National Bank, and received the reply that he had not been at the bank that day. The police were at once notified and the firm looked up the missing stock, which was inventoried as follows: One diamond brooch sunburst, set with a large pearl and 15 one-half karat diamonds; diamond ring of two karats; solitaire diamond earrings of one karat each; diamond stud of two karats; one pair diamond links and a turquoise ring surrounded by diamonds. He took with him \$350 in cash and about \$500 in checks. Later in the week he was captured at Fairchance, Pa., and brought to Pittsburgh.

The jewelry and checks were found upon him, but he had made away with \$75 of the cash. He is also short of \$125 in his accounts. He was sent to jail in default of \$1,000 bail. The Grand Jury returned a true bill against him on Friday.

Jeweler Merritt, Northville, Mich., announces that he will close out his business, previous to moving elsewhere soon after Jan. 1. Mr. Merritt lately received an offer from the Libbey Glass Co., Toledo, O., to go to Paris to take charge of their exhibit at the exposition. Mr. Merritt represented the same firm at the World's Fair at Chicago.

**WHO SAID WATCHES?**

Ladies' Watches,  
Gentlemen's Watches,  
**Railroad Watches.**

We Are the Largest Distributors of

**Dueber-Hampden Watches**

IN NEW YORK.

*John N. Sherwood & Co.*

Watches. Chains. Diamonds. Jewelry.

**No. 3 MAIDEN LANE, NEW YORK.**

# THE DUEBER HERALD

THE ADVOCATE OF HONEST BUSINESS METHODS.  
\* DEVOTED TO THE RETAIL JEWELRY TRADE.\*

Vol. I.

CANTON, OHIO, DECEMBER, 1899.

No. 10.

## A HURRIED WORD.

No time to talk much.

\* \* \*

You're busy waiting on customers.  
Haven't time to read.

\* \* \*

Therefore, only a hurried word:  
Have you seen the new 12-size Dueber Watches?

\* \* \*

Ever see anything better?

\* \* \*

Also, did you get a copy of the  
new Dueber Catalogue? That's all.

\* \* \*

Wish you a good trade.

## IMPORTANT NOTICE.

The Dueber Herald takes pleasure in recording the remarkable success of the three new 12-size watches placed upon the market by the Dueber-Hampden Works.



“DUEBER WATCH CO.”

## THE LAST CALL.

How's your watch stock?

\* \* \*

Large enough? Good enough?  
Or, does it need embellishing?

\* \* \*

If so, remember the new 12-size Dueber Watches. To say nothing of “The Four Hundred,” for ladies.

\* \* \*

Don't wait another day.

\* \* \*

The new Dueber Catalogue is designed to help you. It will, if you let it.

\* \* \*

Merry Christmas.



“JOHN HANCOCK.”

The movements are made in three grades, viz.: The “John Hancock,” the “Dueber Watch Co.” and the “Dueber Grand;” and are sold only in the 14 and 18 karat solid gold and 14-karat gold-filled cases of the Dueber Watch Case Co.

They have been voted the handsomest and closest-running watches ever produced. A detailed description of their merits will be published in a later issue of *The Dueber Herald*.



“DUEBER GRAND.”

# Simplicity of Construction

combined with superior workmanship, is what makes the

## Trenton Watches

the most reliable of all low-priced movements.

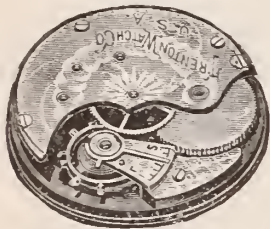

Trenton, 6 size, stem-winding, lever setting, Hunting, 7 jewels, nickel damaskeened, brass and steel composition balance, screw bankings, straight line lever escapement, hardened and tempered hairspring, quick train.

The "Trenton," for the price, far surpasses any movement ever placed upon the market.

SEND FOR PRICE-LIST.

**The Trenton Watch Co.,**

Trenton, N. J.

### New York City Opticians Condemn Some Practices of Ophthalmic Hospitals.

The regular monthly meeting of the Optical Society of the City of New York was held Wednesday, as usual, at the Fifth Avenue hotel, this time in room 15. The scientific session opened with a lecture by Prof. Fox on theoretical optics and his discourse was mainly upon the calculation of the catoptric power of convex and concave mirrors. President Ferguson then followed with an interesting lecture on anisometropia. The business session then commenced, and H. W. Appleton, in the absence of Secretary Dilworth, read the minutes, which were approved and adopted. The following applicants were unanimously admitted to membership: Danl. Rosche, Denver, Col.; Chas. D. Mueller, Newport, R. I.; Richard Stroubel, H. Valiant and Mrs. Booser, New York. President Ferguson then addressed the meeting upon the violation of the Dispensary law by the numerous hospitals and dispensaries of the city. At the conclusion of his address he read the following resolutions, which, after a full discussion, were unanimously carried:

*Whereas:* Section 25, Chapter 368 of the laws of 1899 of the State of New York expressly forbids the hospitals of this State from the giving of free medical or other treatment to those that can afford the same, under severe penalties; and,

*Whereas:* A number of Ophthalmic Hospitals in the City of New York continually violate the letter and spirit of this enactment by the giving of free treatment to patients who can afford to pay, as is evidenced by the sale of gold spectacles in many cases on the part of said hospitals to their "poor" patients; and,

*Whereas:* The prices charged the poor patients at the Ophthalmic Hospitals for their spectacles are at variance with the purport and intent of charitable institutions: rarely less and frequently more than the current prices of the best opticians; and,

*Whereas:* The commercial and lucrative sale of spectacles on the part of the hospital authorities to their patients brings them into competition with legitimate opticians, such practices being a violation of the State law under which such hospitals derive their charter; and,

*Whereas:* That such practices tend to nullify the intent of the laws which have been passed for the relief of the poor,

**THEREFORE BE IT RESOLVED:** That the Optical Society of the City of New York, assembled in session at the Fifth Avenue Hotel, condemns the practices of Ophthalmic Hospitals, whose staffs either write their prescriptions in unintelligible ciphers, or engage in the commercial sale of spectacles themselves, or appoint "official opticians" for the same purpose without submitting such work to be done by the lowest reputable bidder.

### New Rules in Bankruptcy.

Judge Brown, of the United States District Court, last week promulgated the following additional rules in bankruptcy:

XIV.—Case Closed; Stay Vacated.—If no meeting of creditors has been held, the case shall be deemed closed at the expiration of one year from the date of adjudication, and any stay granted thereon shall thereupon be deemed vacated unless otherwise ordered by the Court.

XV.—Indemnity Account.—The referee's certificate that the case is closed should be accompanied by an itemized statement of the sums deposited with him as indemnity, and of the items of charges against the same with the dates thereof, and of the balance remaining, if any; and upon the receipt of such statement, together with a certificate that the case is closed, the deposit shall be paid over by the Clerk.

XVI.—Fees on Special References.—On references of specifications in opposition to discharge, or other special references not within the ordinary duties of referees, they shall be entitled to \$3 per day, the rate of compensation of United States Commissioners in civil causes; and the referees in such cases will be also designated as special Commissioners.

XVII.—Notices to Creditors.—All notices mailed by referees to creditors shall have printed upon the envelope enclosing the notice the name and address of the referee, with direction to return the same to him if the person addressed is not found within ten days. Returned notices or a list thereof shall be preserved and reported as required.

### Proceedings of the Jewelers' Security Alliance.

The regular monthly meeting of the executive committee of the Jewelers' Security Alliance was held on Dec. 8, the following being present: President Bowden, Treasurer Karsch, Secretary Noyes and Messrs. Stern, Sloan and Untermeyer.

The following new members were admitted: Hopkins & Witty, Dubuque, Ia.; H. C. Morrison, Mt. Pleasant, Pa.; Warren Prior & Son, Fayetteville, N. C.; H. B. Carswell, Kansas City, Mo.; Gurney & Ware, Kansas City, Mo.; L. J. Marks, Kansas City, Mo.; Jacob P. Ernst, Wilkesbarre, Pa.; Chas. W. Uhrig, Gallipolis, O.; John F. Zugschwert, Carnegie, Pa.; Jeremiah A. Angell, Providence, R. I.; Emile Bourquin, Horton, Kan.; The S. C. Scott Mfg. Co., New York; C. V. L. Pitts & Son, Kingston, N. Y.; H. E. Adams, Tampa, Fla.; L. H. Jewett, Saugerties, N. Y.; Victor E. Zoeller & Co., Wilmington, N. C.; E. G. Alber, Kansas City, Mo.; Dave Finkelstein, Kansas City, Kan.; Meyer Jewelry Co., Kansas City, Mo.; Frank Winkler, Kansas City, Kan.; Loring Andrews & Co., Cincinnati, O.; Klee & Groh, Rochester, N. Y.; Simon Zausmer, Waverly, N. Y.; E. P. Campbell, Kansas City, Mo.; E. A. Doyle, Lynn, Mass.; A. Hartman, Brooklyn, N. Y.; Rich & Allen Co., Chicago, Ill.; Jas. A. Wilson, Kansas City, Mo.; D. I. Kramer, Salida, Col.; Peter Holler, Brooklyn, N. Y.; J. & C. Mundie, North Tonawanda, N. Y.; W. A. Sturgeon & Co., Detroit, Mich.; B. Lillienfeld, Norfolk, Va.; Richard W. Wehrle, Indiana, Pa.; Raine Jewelry Co., Cripple Creek, Col.

## BEER STEINS,

For Prizes, Club Use and Home Decoration.

75 Cents to \$4.50 Each.

**L. W. LEVY & CO.,**

Novelties and Optical Goods,

194 BROADWAY, NEW YORK.

Successors to Levy, Dreyfus & Co.

## S. STERNAU & CO.,

204 CHURCH STREET, NEW YORK.

Manufacturers of **METAL WARES**

In Brass, Copper and Silver.

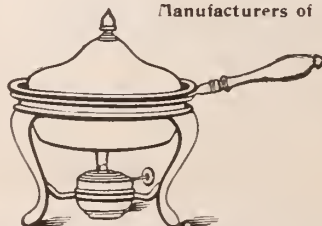

**CHAFING DISHES,  
KETTLES, TRAYS,**

Crumb Trays and Scrapers. Bread Baskets, Etc.

CATALOGUE ON APPLICATION.



**Death of Eugene H. Richards.**

BOSTON, Mass., Dec. 14.—From ancient King's Chapel to-day were borne with all the honors due to his exalted rank in the Masonic body the remains of the late Eugene H. Richards, formerly one of the best known men in Boston, prominent in the jewelry manufacturing trade and beloved by many associates in various walks of life.

Mr. Richards was born in Attleboro, Mass., 56 years ago. He was a graduate of Tufts College and a veteran of the Civil War. He was also a member of Boston's famous organization, the Ancient and Honorable Artillery Company. As past commander of Post 113, G. A. R., he was identified with some of the leading citizens of Boston in military circles, and as past grand commander of the Grand Commandery of Massachusetts and Rhode Island, Knights Templar, he was equally well and widely known in the Masonic fraternity, which had bestowed upon him the 33d degree.

His death took place last Monday night at the McLean Asylum for the Insane, of which he had been an inmate for about a year. The death of his wife, which occurred about three years ago, was an affliction from which he never rallied. His business suffered and reverses financially followed this severance of domestic ties. Shortly before his commitment to the hospital at Waverley his failure, for the second time within a brief period, was announced, and the business which he had conducted for a number of years at 7

Green St., in this city, passed into other hands.

The services at King's Chapel have rarely been exceeded in impressiveness. The full Knights Templar service was performed under the direction of Boston Commandery, and dignitaries of the order took part in the ceremonies. At the close of the services in the church the body was taken under escort of Masonic and Grand Army comrades to South Attleboro for burial.

**Death of Bennett W. Ellison.**

Bennett W. Ellison, for the past 35 years connected with the jewelry trade of New York and Providence, as manufacturer and salesman, died of quick consumption Sunday morning, at 8 o'clock, at the residence of his daughter, 58 Morningside Ave., New York. The interment took place yesterday in Calvary Cemetery.

"Ben" Ellison, as he was familiarly called, was known to nearly every jewelry manufacturer, jobber and salesman in the United States. He was born in Poughkeepsie, N. Y., 57 years ago. At the age of 18 years he enlisted in the Union Army and served throughout the war. He was more than once mentioned by the commanding officer for his special acts of bravery, and when mustered out he left the army as Colonel Ellison. After the war he went to New York and engaged in the jewelry business, which he continued until the day of his death. He leaves a host of loyal friends, who will mourn his death.

**Death of Frank M. Avery.**

CHICAGO, Ill., Dec. 16.—Frank M. Avery, vice-president of the Chicago Brass Co., died on Wednesday at the Lancaster hotel. Dr. Noel, representing Coroner Berz, finds gastritis as the cause of the death. Mr. Avery called at the hotel Tuesday and when assigned to a room gave the name of Charles Williams, but refused to register. He spent the afternoon in writing and about 8 o'clock called the bellboy and gave him two letters to mail, one of which was directed to a woman. The other, the boy thinks, was addressed to Mr. Avery's father. Early next morning the chambermaid reported that Mr. Avery was unconscious. At that time his identity was not known. Shortly after this Dr. Frank Billings and a Dr. Miller, sent, it is said, from the Avery residence, 2123 Prairie Ave., arrived at the hotel. They remained with Mr. Avery until 2 o'clock, when he died. Both physicians immediately signed a death certificate attributing death to acute gastritis.

Frank M. Avery was the son of T. M. Avery, former president of the Elgin National Watch Co., and was a member of the Calumet, Chicago, Washington Park, Illinois, and Chicago Athletic clubs. He was 36 years of age and leaves a widow and one child.

The lace curtains in W. H. Van Keuren's jewelry store, Poughkeepsie, N. Y., became ignited from a gas jet a few evenings ago. The flames were extinguished before much damage was done.

**WALTHAM WATCHES**  
ARE CARRIED ALL OVER THE WORLD



No  
333

*No watch ever made  
has sold as well as  
No 333*

It is the only nickel watch that comes anywhere near the style and beauty of the fine gold cases :

It is 14-size and modeled so that it does not bulge out the pocket :

It has a jeweled movement, is thoroughly tested and carries the same guarantee of accuracy as we give all our watches :

It is the popular size for men, yet not too large for a boy :  
Not dead stock at any season —at this season it is *the quickest-selling article a jeweler can handle :*

Arabic, Roman or Card Dial :

**NICKEL OR GUN METAL.**

*New England Watch Co.  
WATERBURY, CONN.*

No  
333



**Reciprocity Treaties.**

**Features of Treaties Now Before the Senate for Ratification of Interest to the Trade.**

WASHINGTON, D. C., Dec. 16.—The President has submitted to the Senate for ratification the several reciprocity treaties that have been completed during the past Summer. Among the provisions contained therein are the following items of interest, viz.:

The treaty for the Barbadoes, signed June 16, 1899, provides for the free admission into that colony of clocks, while glass ware and cutlery will be admitted upon a payment of duty at 5 per cent ad valorem. Similar provisions are contained in the arrangements with British Guiana, under date of July 18; while the treaty with Turks and Caicos Islands admits watches in addition to the above.

The treaty with Jamaica, under date of July 22, allows a free importation to tortoise shell when imported from Jamaica into the United States in its crude state. On the other hand, we may ship to Jamaica free of duty magic lanterns and slides, also photographic apparatus.

Under treaty with Bermuda, bearing date July 24, clocks are to be admitted free of duty.

In accordance with the terms of the treaty made with France under date of July 24, it is provided that entries of merchandise from the United States will be accorded the minimum rate of duty, with the exception of certain articles, none of which are of any interest to the jewelry trade. In return we yield to the merchandise received in the United States from France the following reductions: On imitation jewelry, a reduction of 10 per cent; jewelry, 5 per cent; fans, 10 per cent; articles of amber, bone, ivory, mother-of-pearl, shell, meerscham, 15 per cent; buckles, 10 per cent; glass decanters, 5 per cent; spectacles and glasses for spectacles, also opera glasses, lenses, etc., 10 per cent; cutlery, 10 per cent; watchmakers' articles, clocks, 15 per cent; metallic pens, pen holders, 10 per cent, from the rates of duty as established under the present Tariff act.

**The Creditors of Theo. Schelle Will Receive No Dividend.**

CHICAGO, Ill., Dec. 16.—The creditors of Theo. Schelle, retail jeweler, Milwaukee, have been advised that there will be nothing left from the assets for a dividend. Mr. Schelle's store was closed by the

sheriff July 20, 1898, on judgment for \$11,808 and some time later he made an assignment. Some time previous he had bought out a party named Gilowski and assumed the latter's indebtedness, which he failed to pay. Gilowski to protect himself closed down on Schelle. His claim against Schelle was thought to be preferred in violation of the bankruptcy act, but the Court has decided otherwise and nothing is left for the general creditors. As Schelle had been slow in his payments for some time previous to his failure, the outstanding indebtedness in this city is small.

**Mrs. H. J. O'Neil Regains Her Liberty and Her Goods.**

MONTREAL, Can., Dec. 16.—Judge Choquet yesterday afternoon heard the arguments of counsel on the difficulties that have arisen in connection with the report and evidence taken by L. W. Sicotte who was appointed commissioner to hear witnesses in the United States for the prosecution in the case against Mrs. H. J. O'Neil charging her with defrauding her creditors out of several thousands of dollars' worth of goods. Messrs. Martin and Foster, for the prosecution, contended that, while the depositions of the witnesses were not signed by them and the stenographers who took down the evidence did not swear that their shorthand notes were correctly extended to long hand, it was sufficient that the commissioner as an officer of the court should declare or certify that the documentary evidence produced was correct.

Mr. Fitzpatrick and Mr. Markey, for the defense, contended that there were many mistakes and irregularities connected with the commission. It should never have been appointed in the first place. It was appointed by the Judge of another court while the case was still in the hands of Judge Choquet. In any case the report of the commissioner should have been returned to the court which appointed him and not to Judge Choquet.

Judge Choquet to-day ruled that the evidence taken by Judge Sicotte could not be admitted, because the commissioner had not given the proper notice to counsel. As there was no evidence before the court to support the charge, Judge Choquet discharged Mrs. O'Neil. The civil actions were also withdrawn, and, the seizures being removed, Mrs. O'Neil regains possession of the goods and is once more at liberty.

**NEW LINES.**

**NEW FIRM.**

**SEAMLESS-SOLID-GOLD-FILLED  
.... RINGS ....**

**THESE ARE A SPECIALTY WHICH IS MEETING WITH GREAT SUCCESS.**

*New York Representative :*  
W. M. BOOTH,  
No. 3 Union Square.

**CHASE MFG. CO.,**  
40 Clifford St., PROVIDENCE, R. I.

*Western Representative :*  
I. S. RICHTER,  
Chicago—Stewart Bldg.

Manufacturers of Link Buttons, Shirt-Waist Sets, Locketts and Charms, Beauty Pins, Tie Holders, Chain Pins, in Rolled and Electro Plate.

**Auctioneers Compensate International Silver Co. for Wrongful Use of Names.**

The International Silver Co. last September commenced an action in the United States Circuit Court against Edw. Cane or Cohen and Sigmund A. Lehman, auctioneers, who were then conducting a sale at 36 E. 14th St., New York. The auctioneers had used above their door a sign stating that the entire stocks of Simpson, Hall, Miller & Co.'s and Rogers Bro.'s silver ware were there on sale and the suit was to restrain the auctioneers from using the name of either of these concerns, and from representing that they were authorized or employed by any of the companies controlled by the International Silver Co. to dispose of goods. The International Silver Co., as published in THE CIRCULAR Sept. 13, obtained a preliminary injunction restraining the auctioneers from committing any of the acts complained of, and the signs were at once taken down. The suit for a permanent injunction and for damages was continued in the United States Circuit Court, but the defendants, however, from time to time, obtained an extension of the period in which to file their answer.

The action has now been settled out of court by the auctioneer paying costs and expenses to date to the International Silver Co. and stipulating that they will never again commit any of the acts which the preliminary injunction restrained them from doing. Upon these conditions Geo. M. Pinney, of Pinney & Thayer, attorney for the International Silver Co., has agreed that the suit be discontinued.

**Who Are the Le Maire Optical Co., to Be Incorporated with \$1,000,000 Capital?**

An announcement was made in the daily papers Monday that the Le Maire Optical Co. were to be incorporated at Albany, N. Y., with a capital of \$1,000,000, and were to have two factories that would give employment to 5,000 men. One factory, it said, was to be at Franklin Park, Ill., and the other in Connecticut. Machinery valued at \$500,000, it was stated, would be imported for their plants. The accounts went on to speak of the Le Maire Optical Co. as having factories in London and Paris, and gave the impression that this was the concern owned by Jean Baptiste Baille, of Paris, who manufactures the

well known optical goods under the name, "Lemaire."

The principal importers of the genuine Lemaire optical goods told a CIRCULAR reporter that they do not believe that the company to be incorporated have anything to do with the manufacturer of the original Lemaire products. At the office of the Le Maire Optical Co., a concern at 177 Broadway, New York, a reporter was informed that they were not the concern to be incorporated, but that they might probably consolidate with the Le Maire Optical Co., spoken of, after the incorporation took place. The Le Maire Optical Co. to be incorporated, it was here said, now have quarters on the parlor floor of 32 E. 23d St.

**Whiting Mfg. Co. Suit Against Jos. H. Bauland Co. Settled.**

An action commenced a little over a year ago by the Whiting Mfg. Co., New York, against Jos. H. Bauland Co., Brooklyn, has been settled out of court and discontinued without costs to either party. It will be remembered by the readers of THE CIRCULAR that the action was commenced in November, 1898, to restrain the defendants, who run a department store, from an alleged improper use of the plaintiffs' name. The Bauland Co. had purchased a stock of silver ware from Fred'k. Loeser & Co., and in advertising these goods had used the name "Whiting" in a way that the plaintiff company claimed would induce people to believe that the goods were made by the Whiting Mfg. Co., whereas they were made by Frank M. Whiting & Co. They, therefore, brought an action in the New York Supreme Court to restrain the defendants from so advertising the goods and obtained a restraining order for a few days. A motion for a preliminary injunction was denied by Judge Prior and the case went on for trial. The defendants, in their briefs, stipulated not to use the name Whiting Mfg. Co., Whiting Co., Whiting or Whiting's.

Rounds & Dillingham, the attorneys for the Whiting Mfg. Co., stated to a CIRCULAR reporter, Monday, that the suit had been settled out of court on a basis satisfactory to both parties. The defendants, they said, no longer continued the acts complained of, and, in fact, had sold out their silver ware department. The order formally discontinuing the action, the attorneys said, would be entered to-day.

**Unlimited Variety**

of designs can be obtained in the Bell Gold-Filled Watch Cases, as any special device your customer may desire—any emblem, portrait, monogram, building, etc.—can be engraved for the asking.



The Bell Gold Filled Cases have the best guarantee and are the most profitable cases to sell.

**Buy of the Maker.**

**THE BELL WATCH CASE CO.,**

**CINCINNATI, OHIO.**

**Mossberg & Granville Mfg. Co.,**

PROVIDENCE, R. I.

**HEADQUARTERS FOR JEWELERS' AND SILVERSMITHS' MACHINERY.**

GRINDING AND POLISHING JEWELERS' ROLLS A SPECIALTY.

N. Y. Office, 26 LIBERTY STREET.

Exhibition at the Philadelphia Bourse.

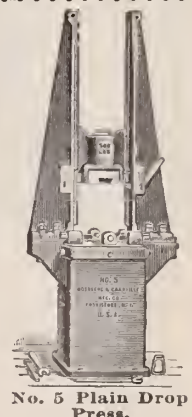

No. 5 Plain Drop Press.

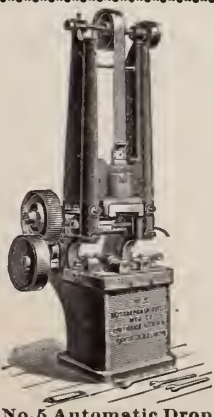

No. 5 Automatic Drop.

**STERLING  
SILVER  
GOODS ONLY**



**FRANK M. WHITING & CO.**

**SILVERSMITHS**

**NORTH ATTLEBORO  
MASS**

1128 B'WAY, NEW YORK.  
220 SUTTER ST. SAN FRANCISCO.

**CONSULT**

**“The New York Jeweler”**

Before Buying Jewelry or Kindred Lines.

For 26 years the acknowledged authority for all that is new, artistic and beautiful in the Jewelry World.

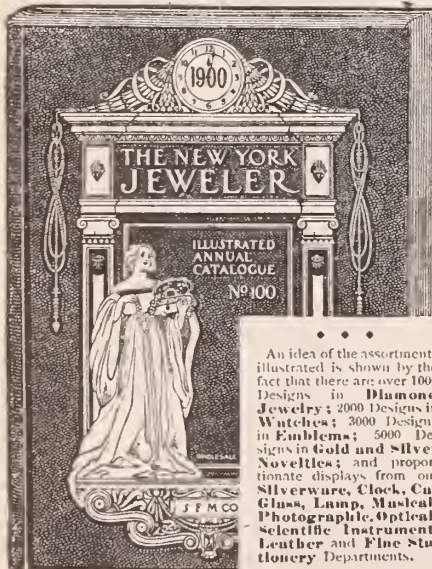

An idea of the assortments illustrated is shown by the fact that there are over 1000 Designs in Diamond Jewelry; 2000 Designs in Watches; 3000 Designs in Emblems; 5000 Designs in Gold and Silver Novelties; and proportionate displays from our Silverware, Clock, Cut Glass, Lamp, Musical, Photographic, Optical, Scientific Instrument, Leather and Fine Stationery Departments.

724 Pages. Size, 9x13.

This profusely illustrated catalogue enables the dealer to make a better selection than the majority of travelers' stocks affords.

**S. F. MYERS CO.,**

MANUFACTURING and WHOLESALE JEWELERS

Myers Building, 48-50 Maiden Lane, New York.

Mention Dept. G 12 when sending for catalogue.

**Bonschur & Holmes's Optical Establishment Burned Out.**

PHILADELPHIA, Pa., Dec. 17.—The handsome new building of Bonschur & Holmes, opticians, 1533 Chestnut St., was burned out early this morning, causing a loss of nearly \$10,000. The fire is supposed to have originated in an explosion of chemicals. About 1:10 o'clock six or seven loud reports were heard within the Bonschur & Holmes building and in a few seconds flames were seen shooting up the elevator shaft close to the front of the building. When the engines arrived the fire was burning at a fierce rate in the rear of the building. Bonschur & Holmes's portion, stocked with costly optical supplies, also caught fire, and for a time it was thought the blaze would not be easily controlled. It was nearly half an hour before this was done. The part of the building which escaped fire was badly damaged by water. The reason for the supposed chemical explosions has not yet been determined.

**J. B. Bowden & Co. Pass the Half Century Milestone.**

In a modest and neat card to the trade J. B. Bowden & Co., ring manufacturers, 1 Maiden Lane, New York, make a simple announcement of their thanks for the favors shown to this house during the past half century. The long career of this firm is one of which they may justly feel proud, and merits even more attention by the trade than they have called for. The business was established by Joseph Bowden in 1849 and continued by him under that name until 1874. During the four years following it was in charge of the present head of the firm, J. B. Bowden, his son. In 1878 the name was changed to J. B. Bowden & Co., the partners being Jos. Bowden, the founder, and J. B. and M. L. Bowden, his sons. The business has since continued under this style, and since 1886 the partners have been only J. B. and M. L. Bowden. The firm have the congratulations of the entire trade upon their long and successful career and the trade's best wishes for the future.

F. L. Likens has sold out his stock of drugs and jewelry in Teller, Col., to C. P. Heckler.

**Fire in an Upper Floor of the Gill Building, New York.**

The fire-proof qualities of the 15 story office (Gill) building at 9-11-13 Maiden Lane, New York, were severely tested by a blaze which broke out in the rear of the 12th floor early Friday morning. The painters had been at work in room 1208, in which the fire occurred, and there was nothing in it at the time the blaze was discovered, at 2:45 o'clock A. M., except the paints and materials of the workmen. How the fire occurred is not known, but when the engines responded to the alarm a threatening blaze was in progress. After a strong effort the blaze was put out before it had penetrated beyond this room. A gratifying part of the occurrence was that, although a great quantity of water was used, not one drop leaked through to the office below, nor was any other office in the building injured in any way by the flames or the water.

A peculiar incident was the fact that the office of Eliassof Bros. & Co., on the fourth floor and in the front of the building and far removed from the scene of the fire, was broken into, and their double locked door was found to be completely smashed when a representative of the firm arrived Friday morning. Eliassof Bros. & Co. keep a large quantity of stock exposed in their office and for this reason have their own lock upon the door. They could obtain no satisfactory explanation from the superintendent of the building as to why their locked door was broken open while the offices adjoining, for which the janitor has the keys, were not interfered with.

**Jewelers' Gold Bars Withdrawn and Exchanged.**

*Week Ended Dec. 16, 1899.*

The U. S. Assay Office report:

Gold bars exchanged for gold coin.....\$191,664.24  
Gold bars paid depositors..... 98,562.10

Total .....\$290,226.34

Of this the gold bars exchanged for gold coin is reported by the Sub-Treasury as follows:

Dec. 11 .....	\$54,067
" 12 .....	31,138
" 13 .....	37,706
" 14 .....	16,203
" 15 .....	21,462
" 16 .....	10,759

Total .....\$171,335

**MATHEWS & PRIOR,**

DESIGNERS AND MAKERS OF

**Sterling Silverware**

TO THE LEGITIMATE

**JEWELRY TRADE ONLY,**

245-247 West 28th Street,  
New York City.





**Death of Moses C. Haight.**

ROCHESTER, N. Y., Dec. 13.—The death of Moses C. Haight occurred Monday evening at the Hygienic Institute, Geneva. Mr. Haight was one of the best known merchants of Geneva, where he had been in the jewelry business for 37 years. He had not been in good health for 20 years. Last Summer he was stricken with a disease paralytic in nature and never recovered from the shock, although he had not been confined to his bed until last Friday.

The deceased was 76 years of age. He is survived by one son, Clarence Haight, of Geneva.

**Many Jewelers Pay Last Respects to the Memory of William H. Ball.**

The funeral of Wm. H. Ball, the well known jewelry manufacturer, whose death was announced in last week's CIRCULAR, took place Friday afternoon from his late residence, 184 Clinton Ave., Newark, N. J. The funeral services were largely attended by the friends, relatives and business associates of the deceased and were conducted by the Rev. Dr. Lyman Whitney Allen, of the South Presbyterian Church. Among the pall bearers were Ex-State Treas. Geo. R. Gray, Samuel Beardsley, Louis Liscomb, Wilbur Doremus, David Perry, A. J. Hedges, of A. J. Hedges & Co., Jas. Y. De Mott, John R. Greason, Cyrus Currier, Stephen B. Kent, Henry Jonies and Jas. F. Umpleby.

Among the many jewelers present were: Wm. R. Alling, of Alling & Co.; Henry Hayes, of the Brooklyn Watch Case Co.; Horace Alling; Julius Lebkuecher, of Krementz & Co.; John Hoagland, of Hoagland & Co.; A. J. Kent, F. B. Crane and a number of members of the local jewelry trade, as well as a delegation from the factory of the deceased's firm. The remains were interred at Evergreen Cemetery, Brooklyn.

**R. H. Ingersoll & Bro. Accused of Infringing a Dial Patent.**

Jas. L. Clark, of Chicago, who claims to be the patentee of an original design for watch and clock dials, has commenced an action in the United States Circuit Court in New York against R. H. Ingersoll & Bro., of New York, alleging an infringement by them of his patent. The design, which consists of a dial surrounded by the heads of prominent men of the day and having at the center a portrait of Admiral Dewey, was patented by Clark, Sept. 12. He claims that R. H. Ingersoll & Bro., without license and in violation of his rights, have made and sold dials that clearly infringe his design patent. He asks for the usual accounting and damages and that the infringing dials be destroyed and turned over to the complainant.

A preliminary and a permanent injunction restraining the defendants or their agents from making or selling the alleged infringements are also asked for. The complaint in the action was filed Saturday and a subpoena issued to the defendants.

O. M. Bundy has succeeded to the jewelry and drug business of Childress & Roth, Packwood, Ia.

**Louis Combremont Makes an Assignment of His Business.**

Louis Combremont, an importer and dealer in watch materials and jewelers' supplies at 45 Maiden Lane, New York, made an assignment Friday to Purdy Van Vliet. At the same time an execution was issued against him to the sheriff for \$1,098 on a judgment obtained by the Banque Federale of Switzerland. Deputy Sheriff Rinn found the place locked and in possession of the assignee.

At the office of Maas & Goldberg, the attorneys for Mr. Combremont, it was stated that no definite figures of the liabilities could be given until the schedules were made up. The assignee, it was said, would file these schedules within a week or so. From other sources it was learned that Mr. Combremont's liabilities in this

country amount to less than \$500, while the debts to Swiss houses amount to about \$9,000. The latter are on notes running to 1904. Mr. Combremont, it is said, in 1896 purchased at full price a quantity of stock which was not worth the amount paid for it and two-thirds of which are still unsold. The business will probably be wound up.

S. Harvey Horner has sold out his jewelry business in Caldwell, Kan., to a party named Stevens, and will go east for a considerable stay before again embarking in business for himself.

Of the sufferers in the fire in Augusta, Ga., Dec. 10, were jewelers Lewis J. Schaul, M. L. Freeman and Charles M. Sacre. Mr. Schaul is reported to have carried \$10,000 insurance, Mr. Freeman \$1,000 and Mr. Sacre \$500.

## The Next Few Days

will mean much to the jeweler, and it is our purpose to help him realize every possible advantage which may be derived from a large stock; ours is here to supplement his, and telegrams—the mails are too slow—for Diamonds and Diamond Jewelry will meet with prompt and liberal responses.

BROOCHES, CORSAGE ORNAMENTS,  
RINGS, STUDS, SCARF PINS,  
PEARL NECKLACES.

### HAYDEN W. WHEELER & Co.,

TWO MAIDEN LANE, N. Y.

50 HOLBORN VIADUCT, LONDON.

**SOUVENIR SPOONS**

We are up to the cash buyer. If you are a cash buyer, you must have our special circular on souvenir coffee spoons for cash buyers. We won't give you time, but we will give you price. No jeweler can afford to be without this circular, nor neglect to give us a chance to quote prices in the way of souvenir spoons or souvenir novelties. We have everything in this line.

**SIMMONS & PAYE,**  
 "The Souvenir House,"  
 129 Eddy Street, Providence, R. I.

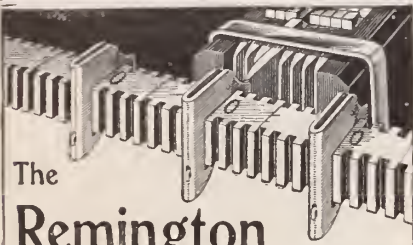

The **Remington**

Billing and Tabulating Attachment  
 accomplishes all kinds of Billing, Statistical, and Accounting Work on the New Models of the

**Remington Standard Typewriter**

as quickly and as accurately as ordinary typewriting is done. It automatically secures perfect perpendicular as well as horizontal alignment.



REMINGTON DEALERS EVERYWHERE SUPPLY IT.

**A GOOD REPUTATION**

is a wonderful help in selling an article of merchandise easily and profitably. The reputation of silver-plated ware with this imprint



MAKES IT EASY TO SELL.

The public have learned by experience that goods bearing the "Anchor" mark are of reliable quality and that their use will prove satisfactory. The U. S. Government has designated the "Rogers Anchor Brand" as the standard of quality and durability.

Send for Catalogues.

**INTERNATIONAL SILVER CO.,**  
 SUCCESSOR TO  
**WM. ROGERS MFG. CO.,**  
 HARTFORD, CONN

New York Warerooms: 9-11-13 Maiden Lane.

**A. R. Justice & Co. Declared Not to Be Involuntary Bankrupts.**

PHILADELPHIA, Pa., Dec. 15.—Alfred R. Justice, F. Milwood Justice and C. Arthur Roberts, general partners, and Fraray Hale, special partner, trading as A. R. Justice & Co. and The Riverton Silver Co., on Chestnut St. near 8th St., were to-day declared not to be involuntary bankrupts by Judge McPherson in the United States District Court. A petition was filed by Silberstein, Hecht & Co. on April 18 last asking that A. R. Justice & Co. be declared involuntary bankrupts. No further proceedings were taken against them and at the hearing the petitioners failed to press their suit.

**Clues to the Cleveland Diamond Robbers Reported Found.**

CLEVELAND, O., Dec. 14.—L. M. Sigler, of Sigler Bros. Co., said to a reporter that he believed the diamond thieves who robbed the store some weeks ago would soon be apprehended. A detective who went to Toledo in connection with the robbery is believed to have brought back important information. The police refuse to divulge it. Both Chief Corner and Mr. Sigler deny that the detective went to Toledo for the purpose of meeting a go-between to make a settlement with the thieves.

The St. Louis police department has sent to the Cleveland police a photograph of a handsome diamond studded brooch, evidently worth hundreds of dollars. The brooch, with a lover's knot of pure gold encrusted with gems, was found in the possession of two Italian laborers who were arrested in St. Louis, Nov. 30. Chief Campbell, of the St. Louis force, confiscated the jewel and is now holding it in anticipation of a claimant.

**Philadelphia.**

Jacob Muhr has returned from a trip to Washington.

Joseph Gigon, New York, has assumed charge of Gimbel Bros.' jewelry department.

Jeweler Fyfe, Girardville, has sold out his store and has accepted a position with C. R. Smith & Son.

William Wildemore, formerly with L. A. Scherr & Co., is now with James D. Hughes, wholesale jeweler.

William Goodall, formerly in business for himself on Market St., is temporarily employed by H. Muhr's Sons.

Charles Flaig, optician, 3224 15th St., has been summoned to act as juror at the next session of the Criminal Court.

The contract for the prizes to be awarded at the amateur boxing tournament has been awarded to Simons, Bro. & Co.

The jewelry and optical store of D. Rosenfeld, 945 S. 2d St., was robbed by a window smasher Saturday night of goods worth \$50.

The handsome silver trophy to be presented to the winner of the shooting tournament of the Riverton Gun Club is being made by Hamilton & Diesinger.

Thaddeus S. Adle, jeweler, Norristown, who was injured in the Exeter wreck on the Reading road some months ago, has compromised with the Reading Railway Co. for \$10,000 damages.

Jacob Muhr, of H. Muhr's Sons, and Mrs. Fannie Muhr last week gave \$250 each toward the new building of the Young Women's Union. Maurice Pfaelzer gave \$100 and his wife gave \$25.

The L. E. Waterman Co. on Friday filed two bills in equity against William F. Murphy's Sons Co., asking that the defendants be enjoined from making alleged infringements on improvements in fountain

**Our Hand-made Cases**

are constructed in the old reliable way, which is a pride to the Manufacturer, Dealer and Wearer.



Manufactured by **DUBOIS WATCH CASE CO.,**  
 Makers of **SOLID GOLD CASES.**

21 and 23 Maiden Lane, New York.



**Eliassof Bros. & Co.,**

IMPORTERS AND JOBBERS OF

**DIAMONDS, WATCHES, JEWELRY,**

9-11-13 Maiden Lane,

NEW YORK.

Materials, Tools and Optical Goods.

ALBANY OFFICE: 62 & 64 STATE STREET.

pens, the patents of which are owned by the complainants.

A foreign attachment was issued from the Common Pleas Court Saturday by the Fairbanks Co. against Philadelphia Jewelry Mfg. Co. Last week a judgment for \$1,421.36 was entered against the same firm.

**Boston.**

**TRADE CONDITIONS.**

Retail trade in the holiday lines carried by jewelers in this city has been equal to that of the previous Christmas with all the leading houses, and most of them report an even better volume of demand than they have known in any previous year. There is a noticeable trade in diamonds and other precious stones. The call for watches is also extraordinarily large. For the general run of novelties of all sorts a good, steady call is in evidence. The wholesalers and jobbers will have their men home from the road until New Year's, as a rule, and can find plenty for them to do as inside salesmen until after Christmas, at least. The past month has been a very busy one for the Boston trade, and satisfactory profits have been possible on the bulk of the goods sold.

F. L. Butman, dealer in fountain pens, gold pens, etc., 332 Washington St., has opened another place of business at 76 Washington St., first floor front, and will carry, in connection with his other goods, a line of Aikin, Lambert & Co.'s gold pens, pencils, etc., at wholesale and retail.

**Connecticut.**

E. Vanderwerken, of Stamford, is running an auction sale.

The E. T. Burgess Cut Glass Co., Middletown, who are going out of business, are selling their stock to the public at 214 Main St., that city.

The Barker Silver Co., who have located in Milford, have rented their spare room in their factory to the Russell-Tomlinson Electrical Co., of Shelton.

The stock of O. G. Richman, Rockville, is being sold at auction. Mr. Richman will retire from the jewelry business and devote his whole time to his optical and repairing business.

J. I. Byam, 54 years of age, died at Cherry Farm last week. He was a foreman at the factory of the New England Watch Co. and had been employed there most of the time since the institution of the concern. He leaves a wife and one son, and also a brother, Charles, who is employed by the American Waltham Watch Co.

The largest mortgage ever recorded in the town clerk's office in Middletown was received by Town Clerk Howard Dec. 15. It was given by the International Silver Co. and the Continental Trust Co., of New York, as trustee, and was for \$4,500,000. This mortgage was given to guarantee the payment of bonds issued by the International Silver Co. This mortgage has been recorded in all towns where the International company own property.

The wind blew with such force against one of the large plate glass windows in John A. Stapf's jewelry store, Dunkirk, N. Y., on the afternoon of Dec. 12, as to crack the glass through from top to bottom and entirely across. The glass was valued at \$75. Mrs. Stapf was alone in the store and said the cracking of the glass was as loud as a pistol shot.



**NOW WHEN YOU RECEIVE A SPECIAL ORDER...**

*for something you may not just have in stock—a fine watch or piece of jewelry or some loose diamonds—write or wire us. Goods by return express—you can depend on it. Many jewelers know this by experience. We should also like to demonstrate it to you.*

**HENRY FREUND & BRO.,**  
11 Maiden Lane, NEW YORK.

**ELK GOODS A SPECIALTY.**



**DESIGNS, QUALITY, PRICES,**

**Small Profits and Large Sales**

combined have created the great demand for the . . .

**10k. and 14k. Gold Jewelry**

MANUFACTURED BY

**HANCOCK, BECKER & CO.,**  
Providence, R. I.

**SOLD THROUGH JOBBERS ONLY.**

We have made a specialty of

**FINE FINGER RINGS**

for more than half a century.

**GEO. O. STREET & SONS,**

24 JOHN ST., NEW YORK.

... Established 1837 ...



**EMPIRE COMBS. SIDE COMBS.**

GOLD AND JEWELLED ORNAMENTED.

**SPECIALTIES IN ROMAN WORK.**

**DAY, CLARK & Co.,**

MAKERS OF FINE JEWELRY,

23 MAIDEN LANE, N. Y.

### Trade Gossip.

The Bell Watch Case Co. and the O. E. Bell Co., Cincinnati, O., are sending out their delayed watch and ring circulars which are catching the trade on late holiday orders. This special will be followed by a new edition the first of the year.

Geo. E. Homer, manufacturer of souvenir spoons, 45 Winter St., Boston, Mass., has made a special design Masonic spoon for Alexander Washington Lodge, Alexandria, Va. It shows in the bowl the chair which Washington used when master of the lodge. The Masonic emblem is on the handle.

The Chase Mfg. Co., 40 Clifford St., Providence, R. I., are making a specialty of seamless, solid gold filled rings that are meeting with marked success. They also have entirely new lines of link buttons, shirt waist sets, lockets and charms, beauty pins, tie holders and chain pins in rolled plate and electro plate.

Among the souvenirs presented this season by retail jewelers to their customers is a booklet sent out by H. Rempe, Danville, Pa. The book is an aid to Christmas shoppers, in that it contains an epitome of the lines carried by Mr. Rempe, classed under divisions enumerating suitable presents for men, for women and for children. Not only are the articles named, but with them are the minimum and maximum prices.

Jewelers will find in the latest price list of hollow ware made by the Meriden Britannia Co., just sent to the trade, a handy

book that will act as an auxiliary in keeping in touch with the various pieces, styles and prices of this ware. The book contains 48 pages, filled with half tone illustrations of the 1847 Rogers spoons, knives, forks, etc., and tables giving in compact form the prices of all the pieces in the different patterns and different grades of plate.

In a circular letter sent out by Edwin W. Drury, of the Non-Retailing Co., Lancaster, Pa., he announces to his customers in the vicinity of Washington, D. C., that he is making his headquarters at the National Hotel, that city, and will be there until Dec. 26. As the goods in the lines this firm carry are scarcer this season than they have been at any time back, Mr. Drury enumerates those lines in watches, cases, chains and bracelets which he can supply without any difficulty.

The optical trade generally will no doubt be pleased with the latest innovations in the line of offset guard eye glass cases, just introduced by E. Kirstein's Sons Co., Rochester, N. Y. This case is known as the "Kordian, Jr.," and is one of the smallest on the market for offset guard eye glasses. It is both compact and neat and suitable for OO eye size glasses. Being open at the end, like the ordinary spectacle case, it is not necessary to open or close the Kordian, Jr., when putting in or removing the glasses, yet it holds them firmly so that the glasses will not drop out.

That prosperity has its disadvantages to the manufacturer as well as the hard

times has been instanced by the experience of W. & S. Blackinton, the well known chain manufacturers of Providence, R. I. The firm, for the first time in their history, have been receiving complaints from some of their customers on account of the delays in the shipment of goods, and this condition has arisen despite every effort on their part to carry on the business with the promptitude for which they are reputed in the trade. The reason for this condition lies in something that cannot be remedied, namely excessive business, and, though the firm have worked their factory to its utmost capacity, they have been for a time unable to keep up with the demands made upon them. Their power has been in operation till 9 o'clock p. m., and their packing department has been worked every night until 10 and 11 o'clock, and in some cases as late as 2 o'clock a. m., but even this effort was not sufficient to fulfill all demands made upon them.

### Lancaster, Pa.

Joseph L. Hohmann, a damaskeener at the Hamilton Watch Co.'s factory, died at his home on Saturday.

J. M. Jenks, of J. M. Jenks & Co., was a business caller among the wholesale trade in New York last week.

The local trade was visited during the past week by Mr. Gray, of Shafer & Douglas; Jesse L. Browne, Henry Freund & Bro.; H. Bodenheimer, Fink, Bodenheimer & Co.; Emanuel Jacobson.

# A Brief Argument.

Why not carry our exclusive and fashionable line of Sterling Silver Wares, and those only?

**Fashionable**, because of their correct design and perfection of manufacture and finish.

**Exclusive**, because they are never found in dry goods stores or made common-place

by illustration in department store catalogues.

**Gorham Goods** have those characteristics, with the further advantage of being of unquestioned quality; their productions are never made below the Sterling standard, 925-1000 fine.

**The Prices** are always made as low as are consistent with this quality, combined with good workmanship.



## Gorham Manufacturing Co.,

SILVERSMITHS,

BROADWAY AND 19TH STREET, NEW YORK.

Branches: { 21 to 23 Maiden Lane, New York.  
131 to 137 Wabash Avenue, Chicago.  
118 to 120 Sutter Street, San Francisco.

Works: { Providence, R. I.,  
and  
New York City.

# The Jewelers' Circular

AND  
HOROLOGICAL REVIEW.

PUBLISHED EVERY WEDNESDAY BY  
**THE JEWELERS' CIRCULAR PUB'G CO.,**  
CORBIN BUILDING, 11 JOHN ST., COR. BROADWAY,  
NEW YORK.

TELEPHONE: CABLE ADDRESS:  
1148 CORTLANDT. JEWELAR, NEW YORK.

A JOURNAL DEVOTED TO THE INTERESTS OF JEWELERS,  
WATCHMAKERS, SILVERSMITHS, ELECTRO-PLATE MANU-  
FACTURERS, AND ALL ENGAGED IN KINDRED BRANCHES OF  
INDUSTRY.

Member of the American Trade Press Association.

Our editorial columns will contain our own opinions only, and we shall present in other columns only what we consider of interest or value to our readers. Advertising matter will not be printed as news.

Advertising rates in THE CIRCULAR are lower, considering the number of tradesmen reached by its large circulation, than in any other jewelry journal.

Notices of changes in standing advertisements must be received one week in advance; new matter can be received up to Monday.

### INFORMATION FOR SUBSCRIBERS.

#### Terms of Subscription, Postage Prepaid.

	PER ANNUM.
United States and Canada, - - -	\$2.00
Foreign Countries in Postal Union, - - -	4.00
Single Copies, - - - - -	.10

New Subscribers can commence at any time.

Payments for THE CIRCULAR, when sent by mail, should be made in a Post-Office Money Order, Bank Check or Draft, or an Express Money Order or Registered Letter. All postmasters are required to register letters whenever requested to do so.

Pay money only to authorized collectors having proper credentials.

**Returning Copies.** Returning your paper will not enable us to discontinue it, as we cannot find your name on our books unless your address is given.

**Changing Address.** In changing address always give the old as well as the new one. Your name cannot be found on our books unless this is done.

**Discontinuances.** We will continue to send papers until there is a specific order to stop, in connection with which all arrearages must be paid; but such an order can be given at any time, to take effect at or after the expiration of the subscription. All such orders will be promptly acknowledged by mail.

**Liability.** The courts have decided that all subscribers to journals are responsible until arrearages are paid in full and an order to discontinue has been received by the publisher.

#### THE JEWELERS' CIRCULAR IN EUROPE.

Among the places in Europe where THE JEWELERS' CIRCULAR is on file are the following:

- LONDON—First Ave. Hotel, Holborn, E. C.; Holborn Viaduct Hotel, Royal Hotel.
- PARIS—Hotel de L'Athene, Rue Scribe.
- LEIPZIG—Handels-Zeitung, fur die gesamte Uhren-Industrie.
- BERLIN—Deutsche Uhrmacher Zeitung, Jager-Strasse, 73.
- GENEVA—Journal Suisse D'Horlogerie.
- AMSTERDAM—Continental Club, Hotel Amstel.
- ANTWERP—Diamond Club, Rue de Pelican.

Vol. XXXIX. Dec. 20, 1899. No. 21.

*Every line of reading matter in THE JEWELERS' CIRCULAR, with the exception of the few brief extracts from exchanges, always properly credited, is written exclusively for this journal. Each issue of THE JEWELERS' CIRCULAR is copyrighted. Permission to quote is extended to other publications provided such quotations are properly credited.*

### The Impulse of **O**UR attention has been called to a trade condition upon which, now that

the Winter days are approaching, comment is thoroughly apropos. It has for some time been the common practice of traveling jewelry salesmen to engage the services of men to carry their cases of goods from store to store of prospective customers. These carriers haunt the hotel corridors, waiting to do just such work, and are to all appearance and experience decent and honest men. With few exceptions the more important jewelry stores—in the cities of the east at any rate—have but a single entrance, through which the salesman must find his way to the proper buyer. While the salesman and buyer are engaged together, the carrier must wait outside the store, sometimes for as long as two or three hours and in the most inclement weather. The jeweler has heretofore had little occasion to give thought to the subject, for he does not come in contact with the carrier, while the salesman hesitates to bring the subject to his consideration. We are sure that many, yes most of the jewelers who at present have no accommodations for these carriers, will, if their establishments permit, make some arrangements for them. No luxurious apartment is in order; only some place—an off room or a hall way—where the men may abide till their employers have ended their interviews.

### Wages and the In- **T**HE restoration by the Elgin National Watch Co. of

their wage scale of 1892 is serving as an argument for many editorials in the press to prove the existence of industrial prosperity. Increased wages usually follow in the wake of any wave of industrial prosperity, so that the advances in this respect, which have been accorded workers generally, may be looked upon as being a conclusive argument. The fact is that in most lines wages have responded more promptly this year to the touches of prosperity than ever before. Of course, those branches of industry that have taken a longer time to convalesce from the depressing effects of the adverse conditions of a few years ago have not been able to keep step with other more favorably situated industries in advancing wages; and perhaps the manufacturing of jewelry has been the last industry to feel this wave of prosperity. The jewelers are going through the crucial period of their year's business, and whether the wave is an overwhelming one as far as they are concerned remains to be seen.

**T**HE Merchants' Association of New York will commence an active campaign at once in favor of the metropolis as the greatest market in this country for buyers. The officials of the organization will send circulars to every merchant throughout the country, setting forth the excellencies of the New York market in every direction, and will work with even more than their accustomed energy to

make the Spring buying season of 1900 the largest in the history of the city. This is a laudable undertaking and will redound to the advantage of the merchants of not only New York but of the country as a whole, for it will arouse the competition of other cities, with the result that buying will be prompter and more general than a policy of inactivity could make it.

**T**HERE are few jewelry and silver ware manufacturers who have any conception to what an extent the inquiry department of THE JEWELERS' CIRCULAR has grown. The replies published in each issue are but a portion of the number of inquiries received every week. It is quite a common thing for messengers to come to our offices with samples of goods to ask who are the makers. Our services in this way can always be commanded. We wish to still further considerably extend this section of our work; so we want dealers to help us by forwarding us a drawing of any mark they come across in the ordinary way of business which they think might puzzle their fellow-tradesmen in tracing. Orders for matching may not always be acceptable either to the dealer or to the manufacturer, but in the interests of both they must receive attention. Often to the dealer and to the manufacturer they mean the opening of new accounts. Every jeweler should have a copy of our work, "Trade-Marks of the Jewelry and Kindred Trades." It will often be the means of making sales or at least of accommodating the best customers. It may occasionally happen that a mark is not in the book or its Supplement. Inquiry to us will bring the promptest possible response.

#### Death of Malcolm Graham.

Malcolm Graham, of the old firm of Schuyler, Hartley & Graham, now Hartley & Graham, who were for many years in the fancy goods and military goods business at 19 Maiden Lane, New York, died early Monday morning at his country residence in Seabright, N. J. Mr. Graham had been ill for several months as the result of an attack of typhoid fever in September.

The deceased was born in 1832 and after receiving his education commenced his business career with Smith, Young & Co., fancy goods importers, 4 Maiden Lane. In 1853 Mr. Graham left this firm and joined G. R. Schuyler and Marcellus Hartley in the firm of Schuyler, Hartley & Graham, who at first devoted themselves to fancy goods and military goods and later became one of the leading military supply houses in the country. The deceased was twice married; first to Miss Annie Douglas, who died in 1872, and four years later to Miss Amelia Whitlock. His widow and four children by his first wife survive him. The deceased was up to the time of his death not only connected with Hartley & Graham, but was interested in the Remington Arms Co., the Union Metallic Cartridge Co., the Bridgeport Gun & Implement Co. and other concerns. The remains will be brought to New York, where the services will be held Friday at the Brick Presbyterian Church. The interment will be at Woodlawn Cemetery.

**BUYERS' INFORMATION BUREAU.**

Questions as to the makers of certain lines of goods, where to buy certain lines, where certain kinds of work are done, the owners of certain trade-marks and other matters relating to the buying branch of a jewelry business will be cheerfully answered under this department. The reader cannot ask too many questions.

PHILADELPHIA, Pa., Dec. 11, 1899.

Editor of THE JEWELERS' CIRCULAR:

We would thank you very much if you can give us the names and addresses of two or three firms which manufacture machinery especially for the turning out of silver ware, such as table services, etc.

Yours very truly,  
NATIONAL ASSOCIATION OF MANUFACTURERS.  
Per W. M. B.

ANSWER:—Mossberg & Granville Mfg. Co., Providence, R. I.; Langelier Mfg. Co., Providence, R. I., make such machinery.

NORWICH, N. Y., Dec. 13, 1899.

Editor of THE JEWELERS' CIRCULAR:

Can you inform us where we may be able to find aluminum cards, where they are made or where they are sold? Any information on this subject will be fully appreciated. Thanking you in advance for any trouble in this matter, we are

Most sincerely yours,  
C. E. MERRITT.

ANSWER:—Reymond & Gottlob, 831 Broadway, New York, can furnish these goods.

WATERTOWN, N. Y., Dec. 11, 1899.

Editor of THE JEWELERS' CIRCULAR:

Can you inform us where we can obtain solid gold cuff buttons set with "Rhodelite" stones?

Yours truly,  
J. S. BAIRD.

ANSWER:—We presume correspondent means "rhodonite." If so, we do not think any manufacturer carries it in stock. If

he will write to Geo. O. Street & Sons, 24 John St., New York, that firm will give him all particulars concerning the stone and furnish, if possible, what he wants.

PLATTSBURGH, N. Y., Dec. 9, 1899.

Editor of THE JEWELERS' CIRCULAR:

Can you find out for me in any way what concern makes a sterling silver berry dish with an edge of strawberries and strawberry leaves? I believe the berries are raised and cut or engraved. If you can tell me who the maker is I will be greatly obliged.

Yours truly,  
CHAS. J. DALE.

ANSWER:—The Woodside Sterling Co., 11 John St., New York, are the makers of this article.

At a meeting of the creditors of Elmer E. Starr, Toledo, O., a few days ago, it was decided to offer the stock of jewelry at public auction. Trustee Lorain C. Miller has charge of the auction.

In the case of Julius Sinks, charged with stealing diamonds and jewelry from the store of D. G. Gallett, Aberdeen, S. D., a settlement has been made. Sinks makes full restitution, pays the county the cost of keeping him in jail for several months and pleads guilty to a minor offense, for which he will serve a brief term in the county jail and escape a long sentence in the penitentiary.

**Trade-Mark Information.**

**Note.**—The publication of our work, "Trade-Marks of the Jewelry and Kindred Trades," containing over 2,250 marks, all told, the accumulation of various works of reference and the ramifications of our business enable us to trace to their origin nearly all marks that may be found on jewelry, silver ware, art pottery and kindred lines, of both American and foreign make. All questions in regard to trade-marks will be cheerfully answered. We would be pleased to have the trade seek the benefit of our facilities regarding the identity of any marks they cannot trace. We would prefer to receive the article for examination; for if the mark is of foreign origin, the slightest difference between a drawing and the original is of great importance. No question is too trivial nor too complicated for consideration under this department.

MINNEAPOLIS, Minn., Nov. 6, 1899.

Editor of THE JEWELERS' CIRCULAR:

Please let us know at once whose trade-mark the



enclosed drawing is, and greatly oblige,

Respectfully,  
WELD & SONS.

ANSWER:—This trade-mark belongs to the Manchester Mfg. Co., 100 Stewart St., Providence, R. I. See page 45 of "Trade-Marks of the Jewelry and Kindred Trades," published by The Jewelers' Circular Pub. Co.

SCHENECTADY, N. Y., Dec. 9, 1899.

Editor of THE JEWELERS' CIRCULAR:

Can you tell me the name of manufacturer of silver butter-dish containing the mark enclosed? It is impossible for me to send article, but instead

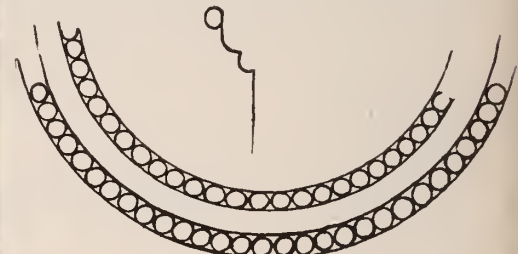

[Full size.]



I send you enclosed a rough sketch of same and hope you will be able to locate maker by this. Thanking you in advance for your trouble, I remain,  
Yours truly,  
CHAS. BICKELMANN.

ANSWER:—With considerable inquiry we have not been able to trace the maker of this article. Can any reader enlighten us on this subject?

The engagement of B. M. Henschee, of Heintz Bros., Buffalo, N. Y., to Miss Lillian Straus, of the same city, is announced.

F. L. Boucher, formerly in the jewelry business at Ackley, Ia., but who has been at American Forks, Utah, for some time past, will locate at Clarion, Ga.

The furnace under the store of M. Menin, jeweler, 198 Market St., Paterson, N. J., became overheated at midnight last Saturday and ignited the flooring. Firemen extinguished the blaze. The damage was slight.

**WIRE US**

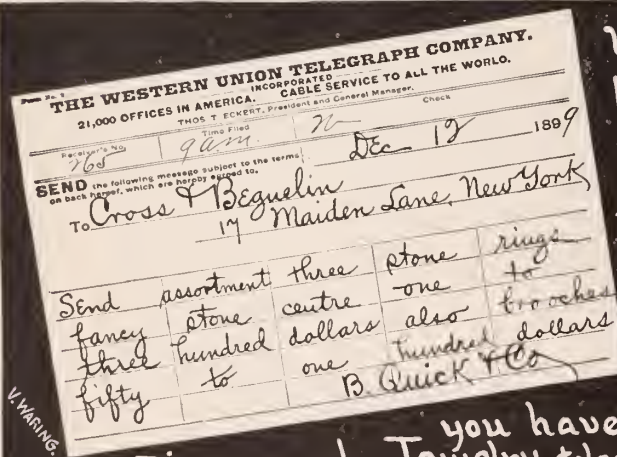

We are prepared for just such orders as this, and fill them soon as received.

If you have special calls for anything

you haven't got in Diamond Jewelry telegraph or telephone just what you want, and you'll get it by return express! Our very complete stock of Mounted Goods is at your service.

**CROSS & BEGUELIN**

Importers and Cutters of Diamonds and Precious Stones

43 Rue de Mestay, PARIS Telephone, 2188 Cortlandt 17 Maiden Lane, NEW YORK

**New York Notes.**

A judgment for \$85.81 has been entered against Moritz Moos by F. C. Finlay.

The Western National Bank has entered a judgment for \$6,786.80 against Eberhard Faber.

Gattle, Ettinger & Hammel have entered a judgment for \$212.60 against Edward W. Carhart.

Judgments against Walton Storm by O. M. Farrand for \$299.89 entered June 18, 1897, and \$226, entered Oct. 21, 1895, were satisfied last week.

Hardy & Co., of Brooklyn, have been incorporated to deal in diamonds with a capital of \$5,000. Henry G. Hardy, George A. Nall and Metcalf B. Hatch, Brooklyn, are the directors.

Frederick C. Manvel, formerly of Ackerman, Bicker & Manvel, was elected clerk of Plymouth Church, Brooklyn, at the adjourned annual meeting held Friday evening.

Creditors of Irving L. Russell, who filed a petition in bankruptcy Oct. 30, are notified that the first meeting of creditors will be held Dec. 26, at 10 o'clock A. M. in the office of Peter B. Olney, referee in bankruptcy, 31 Nassau St. Claims will then be proved and a trustee elected.

John Mason, the former Fifth Ave. jeweler, who failed nearly eight years ago and who recently filed a petition in bankruptcy, was discharged of his debts by Judge Brown, in the United States District Court, Wednesday. Mason's liabilities, according to the schedules filed with the petition, were \$210,257. He had no assets. Mason made his assignment early in 1892 to John Oscar Ball.

At the regular monthly meeting of the directors of the Jewelers' Association and Board of Trade held Thursday, the following firms were unanimously elected members of the association: Samuel R. Zwetow, Denver, Col.; B. Schuette, Chicago, Ill.; Alfred H. Smith & Co., Chicago, Ill.; Seth Thomas Clock Co., Chicago, Ill.; Wm. W. Hayden Co., Newark, N. J., and the Standard Optical Co., Geneva, N. Y.

Since their removal to their new, large and commodious store at 45th St. and Fifth Ave., Marcus & Co., retail jewelers, have put in a silver department. During the many years they were at 17th St. and Broadway, the firm confined themselves almost exclusively to diamond jewelry and did not handle silver. Their new quarters afford them much more room and ample opportunity for a display of fine silver lines. A complete stock of the best

products in hollow ware and flat ware will hereafter be carried by this firm.

Benedict Bros., retail jewelers, Broadway and Cortlandt St., have decided to give up their silver ware department and are now closing out the stock on hand. Read Benedict, of this firm, stated to a CIRCULAR reporter last week that this action was caused by the increase in their watch and fine jewelry trade, which necessitates more room for these departments. As it is impossible to enlarge their present store they decided to give up the silver department and devote the space which it now occupies to watches and jewelry.

The division of old silver and Sheffield plate in the exhibition, at 8 W. 34th St., of the Wernicke collection of antiques is particularly extensive. The silver includes some of the work of the period of George IV., when the hand beater's art was in its zenith, and among the pieces of interest are the silver mounted leather drinking set of Cromwell and the master centerpiece made by Thomire for Napoleon. W. O. B. Clifford, the executor of Mr. Wernicke's estate, has given notice that the disposition of these antiques will not be by the usual auction sale, but that they will be sold privately at cost as entered by the late Mr. Wernicke at the time of purchase abroad.

The formal order of Judge Scott in the dissolution proceedings of the corporation of L. Tannenbaum & Co., mentioned in THE CIRCULAR Nov. 15, has been officially published in the *Law Journal*. The order

provides that persons interested in the corporation shall show cause before Edw. L. Parris, the referee, 261 Broadway, on Feb. 10, at 2 o'clock P. M., why the concern should not be judicially dissolved. The company have done no business since June 8, have no assets and no liabilities. The corporation were organized by Lippman Tannenbaum on Sept. 24, 1896, and had a capital stock of \$500,000. The corporation should not be confused with the firm of L. Tannenbaum & Co., a partnership at Maiden Lane and Nassau St., who are doing business as usual.

The police are looking for three men who Thursday afternoon walked into the watch repairing shop of J. Frank, 12 Market St., choked Frank, stole five watches from his watchmaker's rack, and made their escape into the crowded street. Frank is 85 years of age, and his shop is the front room of his apartments on the ground floor of a flat house. The thieves did not attempt to rifle his pockets, but as soon as they grabbed their booty and before he could recover and alarm the neighbors the men quietly went out and slipped away in the crowd. The police are inclined to believe that Frank's son, with whom Frank has had some trouble, knows something about the robbery. Frank, however, does not think his son had anything to do with it. He said that he would not be sure that he could identify the men if they were caught. Two of the watches which were stolen were Frank's, one gold and the other gold filled, and three silver watches belonged to custom-

While we cannot take any more orders to be made up before January 1st, we have a large and varied stock of CUT GLASS in New York for prompt shipment.

**C. Dorflinger & Sons,**

36 MURRAY STREET,

NEW YORK.

1851.

1899.

**THE CHATHAM NATIONAL BANK, NEW YORK.**

CAPITAL STOCK, - - - \$450,000

UNDIVIDED PROFITS, - - - 974,518

GEO. M. HARD, President.

H. P. DOREMUS, Cashier.

W. H. STRAWN, Ass't Cashier.

ers. In their haste the robbers dropped several watches on the floor.

Alvin L. Strasburger, of Louis Strasburger's Son & Co., returned from Europe last week on the *St. Louis*.

E. O. Zadek, of the E. O. Zadek Jewelry Co., Mobile, Ala., who was ill in New York for several weeks, at 133 W. 47th St., has entirely recovered and with his wife left New York for Mobile yesterday.

The *World* Sunday published an interesting and instructive article on the manufacture of lens glass and the injury done to the eyes by cheap lenses. The article was written by Chas. S. Lembke, president of the American Association of Opticians.

In Alfred Britton, arrested last week by Central Office detectives on a charge of being implicated in the theft of a watch from a pedestrian, the police recognized a famous "pennyweight" thief known under the alias "Tooth Pick," of whom they had lost track for the last five years. The capture is said to be one of importance and one that may save the jewelry trade some trouble and loss.

Applications for tickets for the coming banquet of the Jewelers' Association and Board of Trade, to be held at the Waldorf-Astoria, Jan. 23, still come in at a rate that insures for this the largest attendance of all banquets held in the jewelry trade. The banquet committee, after discussing the subject thoroughly last week, decided to have round tables instead of long ones. These round tables will vary in size, according to the number in the parties desiring to sit together.

Testimony in the action brought by Meyrowitz Mfg. Co., New York, against Eccleston & Sibley, in the United States Circuit Court in Massachusetts, was taken Monday at the office of the plaintiffs' attorney, 31 Nassau St. This action, as already told in *THE CIRCULAR*, was over an alleged infringement on improvements on spectacle frames, patented by E. B. Meyrowitz, and was recently argued in the United States Circuit Court at Boston. The case, however, was reopened Dec. 5 in order that further testimony could be taken and witnesses were examined Monday for this purpose.

There was but little progress made last week regarding the organization of the Sterling Trust Co. and the safe deposit company to be formed in the jewelry trade, as noted in *THE CIRCULAR* from time to

time. John N. Blair, the attorney for the proposed companies, stated Monday that nothing had been done since Mr. Englis had consented to become the president of the Sterling company. There would, however, he said, be a meeting of those who are promoting the companies yesterday afternoon, after *THE CIRCULAR* went to press, after which he expected to be able to report a great deal of progress.

Through the courtesy of Central Office Detectives Madden and Nugent, who are detailed in Maiden Lane, *THE CIRCULAR* is enabled to notify the trade that Jos. Keepers, a notorious jewelry crook, is at large and probably in New York. Jewelers, particularly those who have begun business in recent years and who are not familiar with this thief, are notified to keep a sharp lookout lest he swindle or rob them. Keepers goes by the alias of "Mason," and is a small, thin man, about 5 feet 5 inches in height, with sallow complexion, stooping shoulders and dark brown mustache. He is, as a rule, dressed well, and talks as if he knew about the business. He is an expert at various methods of swindling. He is somewhat eccentric in his manner and is believed to be slightly demented.

A warrant was recently issued for Chas. A. Lyle, a messenger employed at Paterson, N. J., on the complaint of J. Dechert & Co., retail jewelers of that city. Lyle is charged with having failed to deliver four rings valued at \$194 to S. Lindenberg, diamond dealer, 14 Maiden Lane, this city. Dechert & Co. had received five rings on memorandum from Mr. Lindenberg. They kept one and gave the other four to Lyle to return. This was in last July. Lyle claimed that he had delivered the rings but received no receipt for the goods. Dechert & Co. later received a bill from the New York house for the four rings, and confronted Lyle, who, after many excuses, claimed that he had lost the rings, but would settle up. Mr. Lindenberg offered to take off 25 per cent from their bill and Dechert & Co. promised to let off Lyle with an equal amount if he would make restitution. Lyle agreed to pay for the rings at the rate of \$10 a month, but did not do so, and the Paterson jewelers recently learned that he had pawned the jewelry and kept the proceeds. They then went to Judge Hausermann and made a complaint on which a warrant for Lyle's arrest was issued.

### Special Railroad Rates to Merchants Visiting New York.

The lines forming what is known as the Central Passenger Association have granted the application of the Merchants' Association of New York for reduced rates from Central Passenger territory. This covers all that section of the country lying west of Buffalo, N. Y., Pittsburgh, Pa., and Wheeling, W. Va., as far as the Mississippi River, including Chicago and St. Louis, and south to the Ohio river; taking in, however, that portion of northern Kentucky which is traversed by the lines of the Chesapeake and Ohio system. The dates on which reduced rates will be in effect are Feb. 13-17 inclusive and March 1-4 inclusive, with a limit of 30 days from date of sale, the rate of fare being one fare and one-third for the round trip, the general terms and conditions being the same as those heretofore surrounding concessions granted from the same territory.

The Trunk Lines have already granted reduced rates from the territory as far west as Buffalo, Pittsburgh and Wheeling, including Washington on the south for the dates of March 16-21 inclusive, and April 3-6 inclusive, with a return limit of 15 days from the date of sale.

Application for reduced rates of fare is now before the lines of the Southwestern Passenger Association, which covers the State of Texas.

### The Sale of the New York Standard Watch Co.

General Manager Roberts, of the Keystone Watch Case Co., was seen at the company's New York office, yesterday afternoon, by a *CIRCULAR* reporter in reference to the sale of the New York Standard Watch Co., details of which were published in these pages last week. Mr. Roberts said that there was nothing whatever to add to the account which *THE CIRCULAR* published, as that was absolutely accurate and contained all the facts that could be given. No change, he said, would be made in the factory or the business of the New York Standard Watch Co., which would simply be continued as before, only under the control of the same financial interests that now control the Keystone Watch Case Co. and T. Zurburg Co.

## The Mercantile National Bank

OF THE CITY OF NEW YORK,

BROADWAY AND DEY STREET,

Solicits Accounts from the Jewelry Trade.



THE MAUSER MFG. COMPANY,  
SILVERSMITHS,

"Watch Our Ads." 15th St., bet. Broadway and Fifth Ave., New York.



# Our Traveling Representatives



Traveling representatives may consider these columns open for the publication of any news or items of interest regarding themselves or their confreres.

J. R. Rothschild, Ingomar Goldsmith & Co.; and Mr. Sherrill, Sinnock & Sherrill, were in Indianapolis, Ind., last week.

The following traveling salesmen passed through Detroit, Mich., last week: A. A. Richardson, Williams & Winn; H. A. Reichman, Jos.

H. Fink & Co.; Frank E. Wallis, Thos. W. Adams & Co.; A. W. Levy, Byron L. Strasburger & Co.; H. J. Fink, for David Marx; Leo Goldsmith; J. R. Goodwin, Carter, Hastings & Howe; William J. McQuillin, Hodenpyl & Sons; H. C. Barnum, Shafer & Douglas; Harry Osborne, R. Wallace & Sons Mfg. Co.; Fred J. Foster, Unger Bros.; M. F. Thornton, Edward Todd & Co.; Mr. Bliss, Kremenz & Co.; Chas. Lochner, Hayes Bros.; T. H. B. Davis, International Silver Co.

F. C. Steimann, of F. C. Steimann & Co., New York, called on the Twin City jobbers the past week.

E. A. Woodmancy, representing Potter & Buffinton, Providence, R. I., was in Toronto last week.

Asa Richmond, who has been salesman for Wm. Bens & Co., Providence, R. I., has left their employ and taken a position with Burtonwood & Wheelock, Attleboro, Mass.

Benj. Westervelt returned from his Fall trip last week and is enjoying a well earned rest at his home at Mount Vernon, N. Y., where all communications will reach him.

Mr. Tiffany, traveling man for F. H. Sadler & Co., Attleboro, Mass., is home after a trip on the road. Frank Mack, the New York representative, visited the home office last week.

The jewelers of Portland, Ore., were interviewed the past week by I. P. Eisenbach, representing S. B. Champlin Co., Providence, R. I., S. K. Grover & Co., Providence, R. I., and Palmer & Peckham, North Attleboro, Mass.; Jos. Leudan, representing A. Eisenberg & Co., San Francisco, Cal.; John S. Jepson, of Riker Bros., Newark, N. J., and A. F. Lowenthal, New York.

Report has been current that Fauldine D. White, who has made the goods of A. Bushee & Co., Attleboro, Mass., familiar to the jewelry buyers of the whole United States, was about to resign and be succeeded by William L. Bushee, now in the office of the firm. The firm deny this strenuously and are annoyed at the publicity which the rumor has received in salesmen's circles.

Fred M. Brewer has been engaged by C. H. Allen & Co., Attleboro, Mass., to look after that hustling concern's eastern trade. Mr. Brewer is a young man, but he has a large acquaintance with the members of the trade and a wide experience with their methods. He has had charge of the rooms of the Manufacturing Jewelers' Salesmen's Association since their institution in the Fletcher building, and has discharged the duties of that

position efficiently, making for himself many friends who wish him excellent success.

Travelers in St. Louis, Mo., last week were: Walter S. Noon, W. F. Cory & Bro.; Louis Freund, Henry Freund & Bro.; A. J. Sherrard, Enos Richardson & Co.; C. N. Perley, Alling & Co.; B. M. Engelhard, E. Karelsen & Co.; T. E. Rogers, Riker Bros.; De Lancey Stone, Shafer & Douglas; W. H. Gregory, Strobel & Crane; Wm. J. McQuillin, Hodenpyl & Sons; I. B. Ettinger, Gattle, Ettinger & Hammel; A. Pretzfelder, for Manasseh Levy; R. H. Schley, Sloan & Co.; Lawrence H. Smith, Bippart & Co.

The Towle Mfg. Co., Chicago, have been fortunate in securing the services of K. H. Clark to represent them on the road in the territory that was covered by the late O. R. Ryan. Mr. Clark has been with the Meriden Britannia Co. the past two years and was formerly in the retail business at St. Joseph. He is not only at home in silver lines, but is also a good watchmaker, a judge of precious stones, and familiar with every detail of the jewelry business—just the kind of man one likes to talk with. The firm are to be congratulated on the accession of Mr. Clark to their distributing force.

The vacant post of traveler for the Bugbee-Niles Co., North Attleboro, Mass., recently surrendered by Fred W. Brigham, has been filled by the appointment thereto of Frank P. Somes. Mr. Brigham has assumed the grip of another local house. Mr. Somes has for 10 years acted as foreman for the Bugbee-Niles Co., and is perfectly familiar with the goods of the house from close acquaintance with their construction. His employers consider him on this account peculiarly well fitted to talk with the trade in the west. His place as foreman has been filled by the promotion of Daniel H. Chisholm.

Representatives of wholesale houses calling on Syracuse, N. Y., jewelers the past two weeks were: Herman C. Schwartz, Larter, Elcox & Co.; Mr. Wile, Buffalo Jewelry Case Co.; E. H. Cox, Sussfeld, Lorsch & Co.; G. H. Holden, A. C. Geiger & Co.; Fred'k C. Staudinger, E. A. Lehmann & Co.; C. D. Hintze, Enos Richardson & Co.; H. C. Barnum, Shafer & Douglas; Frank G. Moyer, American Watch Case Co.; Mr. Noyes, Ehrlich & Sinnock; V. L. Burgesser, Kremenz & Co.; Dave Zimmern, Zimmern, Rees & Co.;

T. E. Bowne, E. Ira Richards & Co.; S. Glenn Walmsley, for Hermann Baum; E. B. Downs, Hayden W. Wheeler & Co.; Wm. Matschke, F. & F. Felger and A. Joralemon & Son; R. T. Supple, Wm. B. Durgin Co.; J. Goldberg; Frank W. Harmon, M. B. Bryant & Co.; C. F. Sweasy, Wm. B. Kerr & Co.; A. L. Reach, F. H. Noble & Co.; Benj. Westervelt, New England Watch Co., S. & A. Borgzinner, Van Bergh Silver Plate Co., and W. H. Terhune & Co.; H. B. Mount, for A. Wittnauer; Henry Fein, L. H. Keller & Co.; Herbert H. Rosensteel, B. H. Davis & Co.; C. E. Mott, J. B. Bowden & Co.; Rudolph Cony, for Max Nathan; Theo. L. Parker, Martin, Copeland & Co.; W. H. Warrington, J. T. Scott & Co.

Notices of the 10th annual meeting and banquet of the Jewelry Travelers' Association of New England have been sent out. The affair will be held at the Quincy House, Boston, Thursday, Dec. 28, 1899. The executive committee have made a special effort to provide a thoroughly up-to-date entertainment and first-class banquet. The price of the tickets has been reduced to \$1.50, although it is confidently expected that the whole affair will be fully up to any previous occasion, as the entertainment and refreshments are to be provided for out of the treasury fund. Every member is urged to attend and to bring a friend or customer. It is necessary that members should make application for tickets in advance, so that the committee may know how many to cater for. An orchestra has been engaged to furnish music during the evening. Tickets can be secured of the secretary or any of the members of the committee: W. C. Wales, Room 43, Jewelers building; W. B. Snow, Room 34, Jewelers building; W. E. Clement, D. C. Percival & Co.; F. H. Elliott, Smith, Patterson & Co.; Geo. L. Swett, Simpson, Hall, Miller & Co.; E. A. Bigelow, secretary and treasurer, Room 57, Jewelers building, 373 Washington St., Boston.

H. C. Boyd has sold out his stock of jewelry in Mason, Tex.

Chas. Tucker & Son will discontinue their jewelry business in Durango, Col.



## Our New... Jewel Case



has been pronounced by competent judges the best in size, shape, workmanship and fitting, in the market.

Roy Watch Case Co.,

Makers of SOLID GOLD CASES,

21 Maiden Lane,

New York.



TRADE-MARK REGISTERED.

### TO BLOW EFFECTIVELY IS AN ART

which we never practice personally; but we have invented a machine which does it for us, called the

"Reichhelm Pressure Blower."

This, with Gas Furnaces and Jewelers' Tools generally, is the stock in trade of

E. P. REICHELME & CO.,  
23 JOHN STREET, NEW YORK CITY.

## Providence.

### TRADE CONDITIONS.

The manufacturers here are experiencing a comparative lull in the rush of business now. Firms who had been operating their plants 12 to 14 hours a day have gone back to the normal 10-hour schedule, and orders for certain grades of goods, particularly silver and other novelties, have fallen off in the past week. This condition is natural and was expected as Christmas was approached. Such an immense volume of goods as has been turned out has, in effect, drugged the market, but it is believed that all these goods will be gotten out of the way by New Year's, and trade, which will be comparatively quiet in the meantime, will brighten up then and hold good and strong until the first or middle of March at least.

Herbert S. Capron, of Capron & Co., has gone to Havana to spend the Winter months.

Howard Daughaday has severed his connection with J. M. Fraser & Co., whom he has long represented on the road. It is understood he intends to embark in manufacturing on his own account.

William G. Graham has withdrawn from the firm of Graham Bros., 220 Eddy St. The business will be carried on by Thomas H. Graham and D. C. Williams under the style of Graham & Williams. Mr. Williams was formerly in the Minerva Jewelry Co.

A new manufacturing jewelry firm have started at 7 Beverly St., known as the Harvard Button Co. The members are W. A. Locke and Frank Whipple. Mr. Whipple is a member of Slade & Whipple, gold and silver refiners, Attleboro, with whom he retains his connection.

Fuller, Carpenter & Co. expect to be ready to begin business with the new year at their factory, 7 Beverly St., Manufacturers' building. This is the new concern succeeding to the business of the old and well known firm of J. G. Fuller & Co. with the addition of three new members, Edward E. Richardson, Fred Bodman and Fred H. Carpenter, who are leaving the old established house of R. F. Simmons & Co., Attleboro.

A number of buyers called upon the local manufacturers the past week, some of them in search of novelties. Among them were: Messrs. Hemken and Zequil, of Hans Hemken & Co., Chicago; J. A. Selling, Detroit; A. J. Richardson, of Partidge & Richardson, Philadelphia; S. Deutch, of the Jewelry Mfg. Co., Cleveland; Eugene Stern, Philadelphia; L. Block, Buffalo; J. Oppenheimer, of D. Oppenheimer & Bro., Baltimore; J. L. Felsenthal, Chicago; R. Eiseman, of M. A. Eiseman & Bro., Chicago; B. Prentke, of Prentke Bros., Cleveland, and G. Steinfeld, Rochester.

George W. Dover, manufacturer of jewelers' findings, had an experience Saturday evening of such an unexpected nature that he has not yet recovered from the surprise. He was inveigled into one of the private banquet rooms at the club house of the Providence Athletic Association, where he found himself the guest of honor at a dinner provided by some 25 of the heads of departments and skilled mechanics in his factory. Harry Mays, Mr. Dover's superintendent, was largely responsible for the deception practiced upon Mr. Dover. Both are members of a quartette, the other two being Dr. Clarence Davis and George

Freese, who sing quite frequently at various functions in the city. About a week ago Mr. Mays told Mr. Dover that the quartette had been engaged to sing at the athletic club and that the compensation was to be \$60. He said that the Governor and other dignitaries might be present, and the quartette ought to do well. Saturday evening the quartette met at the Narragansett hotel. Then they went to the athletic club. George Pritchard, Mr. Dover's former partner, was made master of ceremonies, and a thoroughly good time was had by everybody present.

## The Attleboros.

The office of the Frank Mossberg Co. was moved into the new factory building Saturday.

Sykes & Strandberg have prepared their first line, put out their new sign, and are ready to deal with the trade.

Thomas Chalmers, prominent in the Ancient Order of United Workmen and foreman for the Attleboro Mfg. Co., died last week at his home, aged 36.

Theron I. Smith, of T. I. Smith & Co., and Henry H. Curtis, of the H. H. Curtis Co., with their families, are planning a trip to California in a few weeks.

The 81x35 foot factory building being erected for F. I. Gorton on Bank St., North Attleboro, is nearly completed and the first of the interior fixtures are being installed.

A meeting of the creditors of the Mason Jewelry Co., Attleboro Falls, has been called for the first Thursday in February. Meantime David E. Makepeace is acting as trustee.

The Torrey Jewelry Co. have taken an office in the Park Row building, New York, and it has been opened for business. Ernest White will handle the interests of the firm in the metropolis.

The Novelty Mfg. Co. have fitted up a new shop in the Wilmarth building and placed Robert Moore in charge. Arthur E. Rhodes, the senior partner, plans to represent the firm on the road.

C. A. Childs, salesman for Charles M. Robbins, Attleboro, has returned from the west. This is the off season in Mr. Robbins's line and at the end of the week he will shut down for a fortnight.

The Danbar, Leach, Garner Co., who have received articles of incorporation and gone into business in the Bates factory, Union St., received their first order Saturday and formally opened their doors to the trade on Monday.

The various concerns who will occupy the S. O. Bigney building are having their new machinery moved in now. The power starts for the Bigney firm on Dec. 27, and probably nearly all the others will take advantage of it at the same time.

Patrick Nihan, head of one of the departments in the factory of the James E. Blake Co., and with Mr. Blake's various enterprises for the past 14 years, left last week to accept a more responsible place in the plating house of David E. Makepeace.

It is credibly reported that the North Dakota Flax Fibre Co. have made a big land deal in Taunton, Mass. This is the concern at the back of which is Henry D

Merritt, Jr., who withdrew a few weeks ago from a partnership in H. D. Merritt & Co., North Attleboro.

The Attleboro Masonic lodge is a body of representative jewelers. In their meeting last week the following prominent manufacturers were vested with authority: Carl Christensen, Frank W. Weaver, Benjamin P. King, Herbert C. Bliss, N. Justin Smith, Everett S. Horton and Alfred R. Crosby.

Grover, Son & Co. have made a change in their personnel, Edgar A. Cummings withdrawing. The concern for the present will be run by Charles L. Grover and his son, Louis E. Grover. The latter has carried the grip for the house for some time. Mr. Cummings prefers not to give out for publication at this time his plans for the future.

There are a number of houses who have been slacking down the past week, allowing help to go, and generally displaying signs of the approach of the end of the Christmas rush. This state of things, however, promises to be reversed at once, for the Spring orders are just beginning to come. McRae & Keeler are quoted as declaring the Spring orders they received the past week to be the largest in their recollection.

Charles H. Cummings has been appointed postmaster of the office at Attleboro Falls by President McKinley. He takes the place the last of the month, leaving a responsible position with J. F. Sturdy's Sons to do so. He succeeds John E. Doran. The latter goes from the office onto the eastern circuit with the grip for Doran, Bagnall & Co., in which house he is a partner. Mr. Doran in his four years has brought the office up one class, has introduced the money order system, and has won praise from residents and superiors by his excellent administration.

Several jewelry buyers from the west and from Canada called upon the local manufacturers and placed large orders the past week. Among them were Hans Hemken, Chicago; a representative of Felsenthal Bros. & Co., Chicago; Al. Stone, of Stone Bros., Chicago; both partners of the Neisser Jewelry Co., Milwaukee; a representative of M. A. Eiseman & Bro., Chicago; representative of S. M. Stern & Co., Philadelphia; William Croft, Jr., Montreal; representative of D. Oppenheimer & Bro., Baltimore; Mr. Selling, Detroit; representative of Prentke Bros., Cleveland, and Mr. Steinfeld, Rochester, N. Y.

The manufacturers in the new Bates building, Mill St., had a little passage at arms last week with Factory Inspector Tierney. It is law in Massachusetts that all doors opening into hallways in factories must be always unlocked to afford egress in case of fire. The occupants of this building are so situated in this regard that to have all the doors of this class unlocked is a serious annoyance. The inspector came and found them locked and gave the manufacturers a very few minutes to alter their plans. After finding protest of no avail they got around it by providing all the doors with knobs on the inside and false knobs on the outside, which will be seen to be both legal and convenient.

# Special Notices.

## Situations Wanted.

**TRAVELING SALESMAN**, silver ware line, desires position Jan. 1, with first-class house; experienced and highest references. Address "Sterling," care Jewelers' Circular.

**PRACTICAL DESIGNER**, with 15 years' experience in all branches of sterling silver ware, desires position; all references furnished. Address "Sterling," care Jewelers' Circular.

**SUPERINTENDENT AND DESIGNER** with large experience in all branches of sterling silver ware desires position; best of references. Address "Designer," care Jewelers' Circular.

**FIRST-CLASS WATCHMAKER** and optician would like situation with first-class firm in Missouri, Colorado or Kansas; state salary in first letter; all references. Address C. G., care Jewelers' Circular.

**SALESMAN** desires position with either diamond or precious and imitation stone house; acquainted with Western, Newark and City trade; highest references can be given. Address B. N., care Jewelers' Circular.

**WANTED**—Situation by an experienced traveling salesman in Middle or Western territory, or such section as would open up a permanent trade to an enterprising and energetic man. "B," care Jewelers' Circular.

**WE DESIRE TO ACT** as New York representative for silver ware manufacturer; have established place of business near Union Square, and wish to communicate with some reliable house. V. M. C., care Jewelers' Circular.

**EXPERIENCED TRAVELING SALESMAN**, 10 years on the road and acquainted with the best trade in the west and middle western States, is open for engagement Jan. 1 to 15; best of references. Address, D. G., care Jewelers' Circular.

**EXPERIENCED SALESMAN** with established trade in New York, Pennsylvania and New England desires position with good, live manufacturers of silver ware or gold goods Jan. 1; salary only. Address, A. L. P., care Jewelers' Circular.

**EXPERIENCED TRAVELER** desires position from Jan. 1; well acquainted with the retail trade east and west; understands diamonds, colored goods, loose or mounted; watches, jewelry or silver ware; best of references. Address A. J., care Jewelers' Circular.

**EXPERIENCED SALESMAN** with established trade for New York City and State, Philadelphia, Baltimore, Washington and Pennsylvania, desires position Jan. 1; 20 years with present firm; highest reference; ring manufacturer preferred. Address L. E. W., care Jewelers' Circular.

**AN OPTICIAN, watchmaker and engraver** wants a steady position with a good firm; understands the business thoroughly; young man, single, sober and steady; have tools and trial case; state salary in first letter; all references. Address "Optician," care Jewelers' Circular.

**EXPERIENCED REFRACTING OPTICIAN** who can command some capital, desiring location, would accept situation to manage retail store or department with view of buying same; state particulars in first letter; references exchanged. Address "Refractionist," care Jewelers' Circular.

**WANTED**—Situation by watchmaker, engraver and salesman; American, 38 years old, 26 years' experience at bench, five years with present employer; fully competent to take entire charge of store or department; if you want sober and industrious man, write me; personal reasons for desiring change. Address "Blue 19," care Jewelers' Circular.

## Help Wanted.

**AN EXPERIENCED TRAVELER** for the middle West to carry a line of diamonds and watches. Address with full particulars, R. A., care Jewelers' Circular.

**WANTED**—Two first-class manufacturing jewelers and stone setters; one first-class engraver and jeweler; references required. Geo. Wettstein, manufacturing jeweler, Cedar Rapids, Iowa.

**AFTER JAN. 1**—A first-class manufacturing jeweler and stone setter who can make all kinds of diamond mountings, cluster work, and understands enameling and the use of dynamos for gilding and plating, as foreman in a newly equipped shop with six to eight men; highest salary and permanent position to right man; best of references required. Address G. O., care Jewelers' Circular.

# INDEX TO ADVERTISEMENTS.

Aikin, Lambert & Co.....	47	Lady Racine.....	40
Aikin, Lambert Jewelry Co.....	47	Lederer, S. & B., Co.....	48
American Watch Case Co.....	47	Ledos Mfg. Co.....	47
American Waltham Watch Co.....	47	Lelong, L., & Bro.....	48
Arstein Bros. & Co.....	18	Levy, L. W., & Co.....	16
Avery & Brown.....	11	Lewis, Fred W., & Co.....	13
Ball, Wm. H., & Co.....	40	Lind, Thomas W.....	4
Barbour Silver Co.....	35	Lintz, Jules J.....	39
Bassett Jewelry Co.....	2	Lorsch, Albert, & Co.....	48
Bell Watch Case Co.....	19	Mabic, Todd & Bard.....	44
Billings, Chester, & Son.....	9	Malliet, C. G., & Co.....	8
Bonner & Co.....	40	Mathews & Prior.....	20
Bowden, J. B., & Co.....	8	Mathey Bros., Mathez & Co.....	2
Bradley Polytechnic Institute.....	48	Mauser Mfg. Co.....	28
Bradley & Hubbard Co.....	4	Mercantile National Bank.....	28
Carter, Hastings & Howe.....	49	Mossberg & Granville Mfg. Co.....	19
Chase Mfg. Co.....	18	Mount & Woodhull.....	8
Chatham National Bank.....	27	Myers, S. F., Co.....	20
Clark & Coombs.....	44	Neuhaus, Theodore, & Co.....	35
Cross & Bequelin.....	26	New England Watch Co.....	18
Crossman, Charles S., & Co.....	11	Nissen, Ludwig, & Co.....	10
Crouch & Fitzgerald.....	47	Omega Watches.....	4
Crown and Lion Watch Cases.....	33	Oppenheimer Bros. & Veith.....	8
Day, Clark & Co.....	23	Patek, Philippe & Co.....	44
Deitch Bros.....	39	Potter, Wm. K.....	48
Dorfinger, C., & Sons.....	27	Providence Stock Co.....	48
Dubois Watch Case Co.....	22	Remington Typewriters.....	22
Dueber-Hampden Co.....	15	Reichhelm, E. P., & Co.....	29
Eaton & Glover.....	40	Reisner, L. C., & Co.....	3
Eisenmann Bros.....	13	Rich, H. M., & Co.....	47
Eliassof Bros. & Co.....	22	Rogers, Wm., Mfg. Co.....	22
Esser & Barry.....	40	Roy Watch Case Co.....	29
Fahys, Jos., & Co.....	37	Rumpp, C. F., & Sons.....	44
Fairchild & Johnson Co.....	48	Saunders, John F.....	9
Field & Beattie.....	44	Schulz & Rudolph.....	43
Foster, Theodore W., & Bro. Co.....	2	Sherwood, John W., & Co.....	14
Frankel's Sons, Jos.....	11	Simmons, R. F., & Co.....	6
Freund, Henry, & Bro.....	23	Simmons & Payne.....	22
Friedlander, R. L. & M.....	48	Simons, Bro., & Co.....	47
Fuchs, Ferd., & Bros.....	44	Smith, Alfred H., & Co.....	10
Goodfriend Bros.....	9	Smith, Wm., & Co.....	44
Gorham Mfg. Co.....	24	Stern Bros. & Co.....	13
Hancock, Becker & Co.....	23	Sternau, S., & Co.....	16
Harris & Harrington.....	48	Strasburger's Son, Louis, & Co.....	12
Haskell, H. C.....	44	Street, Geo. O., & Sons.....	23
Hedges, Wm. S., & Co.....	8	Sussfeld, Lorson & Co.....	43
Heimberger & Lind.....	47	Towle Mfg. Co.....	36
Holmes & Edwards Silver Co.....	35	Treibs Bros.....	11
Hraba, Louis W.....	2	Trenton Watch Co.....	16
Jacot & Son.....	47	Wadsworth, G. F.....	35
Juergensen, Jules.....	43	Waite-Thresher Co.....	38
Kahn, L. & M., & Co.....	48	Wallace, R., & Sons Mfg. Co.....	6
Kahn's Sons, James.....	13	Westphal, W. C. A.....	48
Ketcham & McDougall.....	47	Wheeler, Hayden W., & Co.....	21
Knowles, Dr.....	44	Whiting, F. M., & Co.....	20
Knowles, J. B. & S. M., Co.....	7	Wood, Chas. F., & Co.....	48
Kohn, Alois, & Co.....	40	Wood & Hughes.....	44
		Woods & Chatellier.....	13

**PLATED WARE SALESMAN** wanted to sell a high-grade line on commission as a side line; only those having at least three years' acquaintance with the jewelry trade need apply. Address, "Flatware," care Jewelers' Circular.

**WANTED**—A first-class salesman thoroughly acquainted with the wholesale and retail jewelry trade in and west of Chicago, to take charge of our Chicago office and travel in the west; only those acquainted with the business need apply; best of references required. Van Bergh Silver Plate Co., Rochester, N. Y.

**JEWELRY TRAVELING SALESMEN** to carry a side line on commission of a new collar-button just being put on the market and extensively advertised; only those of high standing and controlling trade will be considered; mention territory now covering; references given and required. H. M. Mays, 235 Eddy St., Providence, R. I.

## Business Opportunities.

**I BUY JEWELRY STOCKS.**—Retailers or wholesalers wishing to dispose of surplus or entire stock of diamonds, watches and jewelry can find quick cash buyer by addressing John Grosberg, 104 2d St., New York.

**JEWELRY STOCKS BOUGHT.**—Retailers wishing to dispose of surplus or entire stock of diamonds, watches and jewelry can find quick, cash, strictly confidential buyer by addressing S. Marx, 22 Lispenard St., New York City.

**FOR SALE. TO CLOSE AN ESTATE.** A jewelry business in one of the brightest towns in Wisconsin. An excellent business opportunity. Capital required about \$3,500.

Address, TOWLE MFG. CO., 149 State St., Chicago.

## For Sale.

**FOR SALE**—Large Mosler fire-proof jeweler's safe; weight, 5,600 lbs., 6 feet high, 4 feet high inside. W. S. Parker, Prairie City, Ia.

## SALESMAN to travel south

wanted with an up-to-date line of medium price Solid Gold Jewelry (Diamond set, &c.), extensive line of Sterling Novelties and high-grade Gold-Filled Vest Chains, Lorgnette Chains, Dumb-bell Links and Brooches. Salary, \$2,000 and expenses. Don't answer this unless you have established trade south, and can furnish high-grade references.

Address with particulars, "WIDE AWAKE,"

Care of JEWELERS' CIRCULAR.

## TO LET

IN THE

## UPTOWN JEWELRY and SILVERWARE DISTRICT,

UNION SQUARE, WEST,

From Feb. 1, for a term of years, No. 19, (second door above Tiffany's), large store, basement, first and second floors; separately if desired. Janitor on premises. Apply to

HORACE W. DAY,

17 STATE STREET, NEW YORK.

TELEPHONE, 724 BROAD.

## Canada Notes.

### TRADE CONDITIONS.

All indications point to a larger and more remunerative holiday trade this season than for years. Retailers were never more lavish in their display of costly and high grade goods, and a very noticeable feature is the extent to which advertising is being resorted to with a profusion of cuts, with the object of obtaining orders by mail. The rush of holiday shopping has fairly set in and business in all lines is exceedingly active.

Judgment has been obtained against W. J. Brydes, watchmaker, Montague Bridges, Prince Edward Island, for \$112.

The bankrupt stock of H. M. Lount, Toronto, is being sold off piecemeal by auction, the sale being continued from day to day.

W. H. Davis, recently of the jewelry firm of H. Davis & Son, London, who retired from business a short time since, has gone to Europe on a six months' tour.

Provincial buyers in Toronto last week included J. Binkley, Hamilton; W. G. Maybee, St. Catharines; W. M. Cross, Sutton; A. E. Tyndale and R. T. Crawford, both of Woodstock.

Wm. T. Short, watchmaker and jeweler, Haliiax, N. S., has moved into his new premises on Gottingen St. He has a large plate glass front and is making an elaborate window display.

Capt. Wyatt, of the Queen's Own Rifles, gave a lecture on "Medals" on the evening of the 12th inst. to a military audience, exhibiting a collection of about 50 with descriptions of their origin and significance.

The business which Barre Bros. & Co., who recently started in the jewelry trade in Halifax, N. S., at Levy & Michaels's old stand, have been doing is reported by the firm to be far ahead of their expectations.

The jewelry store of W. A. Aston, Truro, N. S., has been thoroughly renovated, refitted and supplied with goods for the season's trade. The store's elegant show cases, mirrors and other fittings make it one of the most attractive jewelry stores in the province. The stock was secured principally among New York manufacturers.

Henri Dufréne, charged with stealing jewelry from Alfred Eaves, Montreal, of whom he was an employe, has been sentenced to three months' imprisonment. The leniency of the sentence is accounted for by Mr. Eaves's recommendation to mercy of the Judge. Armand Lefebvre, who was charged with receiving the stolen goods from the former, was given one month's imprisonment.

## Birmingham, Ala.

V. M. Bell has located a jewelry store on Fourth Ave., Decatur.

C. F. Carruth is putting a job lot of jewelry on the market at Heflin.

A stock of optical goods has been put in at Wright's drug store, Talladega.

Dr. E. T. Douglas, Troy, Ala., has put in a stock of optical goods in the jewelry store of J. T. Douglas, Brewton.

C. N. Maxwell, of the C. N. Maxwell Jewelry Co., Tuskaloosa, was the foreman of the Grand Jury of Tuskaloosa county, just adjourned.

The Newman Drug Co., who recently moved from 20th St. and First Ave. to

First Ave., near 21st St., have put in a stock of optical goods.

A. S. Montgomery has opened a place at 2009 Second Ave., where he has a bench and is doing watch work and engraving. Mr. Montgomery was formerly with E. Gluck.

Dock Maddox is again with E. Gluck, and J. T. Talmage, of Jacksonville, Fla., has gone with E. Lowinsohn. John Rosenstihl has also a place with E. Gluck, and Will Rosenstihl with Harry Mercer.

Frank Johnson, the medical student, charged with stealing a diamond worth \$140 from H. C. Abbott & Bro. and selling it to A. S. Smith for a watch and \$50, was acquitted on trial, the Judge holding that there was nothing to show that the stone was not found as the young man claimed.

The ladies of Montgomery will give to Miss Annie Wheeler, daughter of Major-Gen. Joseph Wheeler, of this State, a beautiful loving cup, which is now on exhibition at Le Bron's jewelry store, in the capital city. The gift is in memory of her devoted work in nursing the sick and wounded soldiers in the Santiago campaign. The inscription is: "The ladies of Montgomery to Miss Annie Early Wheeler." On the right of this is a splendid etching of the Alabama State capitol building, and on the left a picture is depicted showing Miss Wheeler ministering to wounded and sick soldiers.

## Henry Bacon Drops Dead.

LOWELL, Mass., Dec. 13.—Henry Bacon, who was a member of the old firm of Bacon Brothers, jewelers, who for years kept the store at the corner of Middle and Central Sts., dropped dead in a store at about 3 o'clock P. M. Dec. 8. Mr. Bacon was seized with a stroke of apoplexy while riding in a buggy with his niece on Broadway. His condition was noticed by several men who were near him, and they carried him into the store and a physician was summoned. Before the doctor arrived, however, death had relieved the aged man. Apoplexy was pronounced as the cause of death.

Chas. H. Judson was last month re-elected Alderman of the 18th Ward of Rochester, N. Y. Both in stature and good nature he is a typical Alderman, and the residents of the "Flower City" should be proud in having his services.

A slight fire was occasioned at the jewelry store of L. W. Zerby, Mahanoy City, Pa., last Monday evening. A bottle containing benzine was accidentally overturned off a work bench on the second floor, and falling on an iron lathe wheel broke, the gaseous fumes igniting from a lamp and spreading to the window curtain, up which they ran, and in turn ignited the sash weight rope, burning it through. The weighted end of the burning rope was drawn back into the boxing of the window, setting fire to the wood-work back of the plastering. The fire company responded to the alarm, but the fire had gained but small headway before it was located and drowned out with a few buckets of water.

## News Gleanings.

Mrs. L. J. LeBoeuf, Woonsocket, R. I., is out of business.

Ashley M. Harger has opened a jewelry store in Lake Mills, Wis.

An execution for \$5,000 has been issued against Jos. A. Link, Allegheny City, Pa.

The business of H. L. Wilson, Platteville, Wis., who recently failed, has been sold out.

The business of Louis Nollive, La Fayette, La., is closed, Mr. Nollive having died recently.

C. G. Wock, of Fort Plain, N. Y., has opened a jewelry store at 599 Main St., Little Falls, N. Y.

W. B. Greenland, Johnstown, N. Y., has recently added a large burglar proof safe to his store equipment.

E. H. Thompson, Buffalo, N. Y., has removed to a much larger and better store in the new block at 301 Connecticut St.

E. R. v. Seutter, Meridian, Miss., whose store was recently burned out, has opened a store on 4th St., between 23d and 25th Aves.

Miss Ella Harrington, Amsterdam, N. Y., has recently placed in her store a very large, handsome, new fire and burglar-proof safe.

E. A. Anderson, jeweler, Saranac, Mich., who was recently burned out, has taken a position with R. E. Von Houten, Ionia, Mich.

One of the handsomest and most cheerfully fitted up stores in Buffalo, N. Y., is the recently remodeled store of Schneider Bros., 355 Genesee St.

Victor E. Zoeller & Co. had their opening last week at their new jewelry establishment, 124 N. Front St., Wilmington, N. C. It is a modern, up-to-date store.

J. P. Swatzell has sold out his stock of jewelry in Elk City, Kan., to C. H. Kerr, who will continue the business in connection with his drug establishment.

James Dolan, who was arrested on suspicion of breaking into the jewelry store of George S. Kelley, New Bedford, Mass., was discharged in court. There was no evidence to connect him with the break.

T. J. Pottinger will continue the business of the Rodgers & Pottinger Jewelry & Optical Co., Louisville, Ky., at the old store. Henry Werne, who will be connected with Mr. Pottinger, has just returned from the east.

On the evening of Nov. 20 the jewelry store of A. L. Hause, room 3, Cook block, Toledo, O., was entered and a quantity of jewelry and gold stolen. No trace of the thieves has been obtained, but last week the case which was stolen was returned to the detectives. The case had been stripped of its valuables.

The Crowell Optical Co., Terre Haute, Ind., are mourning the loss of a \$100 ring. A few evenings ago two persons entered the store and asked to be shown some rings. A tray containing fine goods was set on the show case for their inspection. After examining the rings the shoppers departed, and very soon it was discovered that a fine diamond set ring valued at \$100 was missing.

W. F. Rippman, Millerstown, Pa., has opened his new store.

E. P. Randolph has opened a jewelry store in Millette, S. D.

Ross Quicksall has opened a jewelry store in Mt. Holly, N. J.

E. G. Burlingame has opened a new jewelry store in Elkhart, Ind.

S. N. Ronk, of Hampton City, W. Va., has opened a jewelry store in Kenova, W. Va.

H. C. Milligan, from Keosauqua, Ia., has opened a jewelry store in New London, Ia.

Joseph E. Sykes, 117 Ellison St., Paterson, N. J., has decided to quit the jewelry business.

Albert C. Kraft, optician, Camden, N. J., has opened an office and salesroom at 426 Market St.

William Eberle, Mapleton, Ia., is closing out his stock of jewelry, preparatory to going on the road for a Des Moines firm.

The Bell Jewelry Co., San Antonio, Tex., are now settled in their handsome and commodious new quarters at 227 W. Commerce St.

L. D. Dana, Antigo, Wis., has closed out the branch at Kaukauna, Wis., to Otto Mueller, of Wausau, who was in Mr. Dana's employ for the past year.

The jewelry store of E. A. Bloser, New Kensington, Pa., was relieved of a con-

siderable quantity of valuable goods last Wednesday night by burglars.

Dr. Lutherpher Joseph Weikert has removed his jewelry, patent medicines, watch mending, clock fixing establishment and cigar factory from the corner room of the Livingston block, Center Square, to the middle room of the same building.—New Oxford (Pa.) *Item*.

Burglars entered the store of Howard J. Norfolk and Thomas Pilkey, at Felts Mills, near Watertown, N. Y., last Monday night, and stole a quantity of clothing and 23 watches. James Devine and Moses Cornell were arrested on suspicion of having committed the deed, as a portion of the stolen property was found on Cornell.

The new five-story brick addition to the Fahys watch case factory, Sag Harbor, N. Y., is now about completed and adds about 3,000 feet of floor space to the factory. The structure is surmounted by an octagon tower, which adds architectural beauty to the plant. This tower incloses a huge water tank for fire purposes. This is the only five-story brick building in Suffolk county.

The diamond ring stolen from L. M. Barnes, North Adams, Mass., last year and found when Patrick Killoran and Susie Simmons were arrested in Pittsfield, Mass., was restored to Mr. Barnes, Dec. 11, by the lawyer who had charge of the defense during the trial. The ring con-

tained three diamonds and was valued at \$150. This was the last article of the stolen jewelry to be returned.

A. W. Miller, a jeweler, formerly in the employ of D. F. Sullivan, Rockford, Ill., but now in business at Fort Dodge, Ia., was in Rockford a few days ago, stopping off there while en route to Chicago. One of the objects of Mr. Miller's trip was to secure an opening booking for the new opera house just completed at Fort Dodge. He reports that he is doing well in the jewelry business in his new location.

R. P. Thorn & Sons, Albany, N. Y., have had mounted a shell which was one of the last used by the *Brooklyn* in sending a five-inch projectile into the battered *Viscaya* at the battle without the harbor of Santiago. Three silver handles have been adjusted to it and it is adorned with silver bands. It will be inscribed with a history of its participation in the battle and with the name of its presenter and the date when the gift was made.

Shortly before 6 o'clock on the evening of Dec. 8, a slight fire occurred in the grinding department on the third floor of the E. Kirstein's Sons Co.'s optical establishment, 204 Court St., Rochester, N. Y. The blaze was caused by an employe accidentally dropping a lighted match in a box containing tar. The tar blazed fiercely for a short time, until it was extinguished with a few pails of water. No damage was caused by the fire.



# NO UNPROFITABLE SALES

made by jewelers selling

## CROWN 14 K.

## and LION 10 K.

GOLD-FILLED CASES.

Every Crown or Lion Case sold means a satisfied customer.

### WHY?

**FIRST.**—Because the cases have proved merit and are made up in the latest and most popular designs.

**SECOND.**—Because the guarantees mean precisely what they state. No conditions, no subterfuges.

**THIRD.**—Because they cost no more than inferior goods.

**CROWN 14 K. and LION 10 K. cases are SOLD BY ALL JOBBERS.**

THE EMPIRE WESTWARD TAKES ITS WAY

# WESTERN SUPPLEMENT

## OF THE JEWELERS' CIRCULAR

VOL. XXXIX.

NEW YORK, WEDNESDAY, DECEMBER 20, 1899.

No. 21.

### Chicago Notes.

All communications in reference to the Chicago department of *The Jewelers' Circular*, addressed to Stephen Parlin, 1522 Lill Ave. (Telephone, Lake View 397), Chicago, will receive prompt attention.

Sig. Stern, of Stern Bros. & Co., is here looking over the field.

G. A. Jewett, manufacturers' agent, has returned to New York.

James Mander writes to *THE CIRCULAR* that he is still in the optical department of Otto Young & Co.

T. Y. Midlen, of the New York office, visited the Chicago office of the Gorham Mfg. Co. last week.

H. F. Fitton, Deep River, Ia., has purchased the jewelry department in the store of Converse & Co., that town.

Mr. Loeb will shortly leave for his regular annual business visit to the Wadsworth Watch Case Co.'s factory.

Enoch A. Reed, representing Reed & Barton as western traveler, was at the Chicago salesrooms early the past week on his way east. Mr. Smith, for the same company, also was here.

J. Floersheim, Kunstader & Co. will on Jan. 1 move to the northeast corner of Adams and Market Sts., where they will occupy the entire second floor, a space nearly three times as large as that they now have.

N. L. Bradley, of the Bradley & Hubbard Mfg Co., the past week visited Manager Merrick, of the Chicago house, looked over general conditions in the west and incidentally attended to some personal outside interests.

Buyers in person here were scarce last week. Among them were: L. D. Dana, Antigo, Wis.; George O. Warren, Sycamore, Ill.; W. H. Gruenhert, Green Bay, Wis.; M. G. Peterson, Gibson City, Ill.; M. E. Lubman, Manitowoc, Wis.; W. R. Smith, Geneva, Ill.; Mr. Barstow, Oshkosh, Wis.

At Kinsley's, Jan. 19, is the decision of the committee on time and place for holding the Chicago Jewelers' Association banquet. The time has previously been announced, but the decision in favor of Kinsley's was reached only last week, after offers had been made by a number of the leading hotels and clubs. Those who have attended the jewelers' banquets previously held at Kinsley's will be pleased with the selection of the committee. Next in order is the issuing of the invitations, for there undoubtedly will be a number sent

to out-of-town people, who might not be in a position to accept at short notice.

### Cincinnati.

F. Pairan, an aged jeweler, who formerly conducted a jewelry store in the Grand hotel, died at Madeira, O., a few days ago.

B. S. Newman, of Frohman & Co., accompanied by his wife will spend the holiday season in the east and be in New York by the first of the year to buy goods.

The students of the Hughes High School, of Cincinnati, have chosen a permanent school pin, a flag of red enamel, with the name "Hughes" in white. The design was submitted by Theodore Neuhaus & Co., Cincinnati, who are making the pins.

Bernard Plaut, who for years conducted a retail and wholesale house on Elm St. and who sold out last Summer and went west for his health, died at Salt Lake City last week, and his remains were shipped to Cincinnati for interment in the Walnut Hills Cemetery.

Among the buyers in town last week were: J. H. Mullholland, Springfield, O.; J. L. Wanner, Aurora, Ind.; H. A. Rohs, Cynthiana, Ky.; George W. Keifner, Loo-gootee, Ind.; Baldwin Bros., Winchester, Ky.; W. A. Orwin, Rushville, Ind.; J. D. Ward, Rising Sun, Ind.

One of the holiday events in social circles at Cairo, Ill., will be the wedding of Miss Minnie Buder, daughter of E. A. Buder, jeweler, of that place, to L. F. Biller, traveler for Heintz Bros., Buffalo, N. Y. He made the acquaintance of Miss Buder while selling goods to her father.

George E. Fahys, of Joseph Fahys & Co., was in Cincinnati some days ago on his annual western trip, and he seemed pleased with the great trade of their house this season. He expressed a firm belief of a good Spring trade to follow the big holiday trade, as a natural consequence.

A "fence" has been located in Chicago where has been found much stolen goods belonging to Cincinnati. Among the property is a great deal of jewelry. The detectives have not been able to get a single clue to the Arcade robbery, and the goods from S. B. Duncan's store have not been recovered. It is now believed that the goods were immediately shipped out of the city to some fence. Detective Schnucks is in Chicago endeavoring to identify some of the stuff.

Fred Knell, Perry, Ia., has given a realty mortgage for \$1,000.

### "Railway" as a Watch Trade-Mark.

**Hampden Watch Co. Bring an Interference Suit Against Webb C. Ball and American Waltham Watch Co.**

CHICAGO, Ill., Dec. 18.—Evidence is being taken as to the right to the use of the word "Railway" as applied to watch movements in the case brought by the Hampden Watch Co. against Webb C. Ball and the American Waltham Watch Co. The Hampden Watch Co., as successors of the New York Watch Mfg. Co. and New York Watch Co., have for many years past sold movements under the trade-mark of "Railway" and assert exclusive right to that trade-mark. This trade-mark right has been exercised under common law for about a quarter of a century by the Hampden Watch Co. and their predecessors. In 1893 Webb C. Ball registered the words "Railway Queen" as a trade-mark, and some time ago the American Waltham Watch Co. began to use the registered stamp "Railroad."

The Hampden Watch Co. have started an interference proceeding against the two concerns named as defendants, to assert their priority of right in the trade-mark "Railway" and as against any colorable or varying modification of that trade-mark. It is now pending as an interference case in the Patent Office and the parties to the case are taking evidence. First will come the Hampden Watch Co. evidence, then that of the defendants, and then probably the rebutting evidence of plaintiffs, so it is likely to be some months before the case can be decided.

Spurgeon Callison has removed his stock of jewelry from Macksburg, Ia., to Dexter, Ia.

N. Burton Rogers, vice-president of C. Rogers & Bros., was in Chicago at the end of the week, returning to New York Saturday.

The Cincinnati Chamber of Commerce is constantly receiving letters of inquiry concerning the city's advantages regarding location for manufacturing plants. Recently an eastern jewelry firm, looking for a western location, asked if local capital could be interested to any extent in the matter of bringing a large concern to Cincinnati. They have been investigating large cities, and think that Cincinnati is about the most central location for distribution. The name of the firm is not given out for publication at present.

**Detroit.**

Jeweler F. E. Platte has received his discharge in bankruptcy from Judge Swan.

F. B. McArthur, Bay City, Mich., has opened a jewelry and bazaar stock at Elsie, Mich.

Jeweler Wood, formerly of Pinconning, Mich., has opened up a new store at East Tawas.

J. H. Hollister has removed from 31 Lafayette Ave. to a better location on Antoine St.

Fred Preston has purchased the optical stock and department of Roehm & Son and will rent the space in the store.

The Johnson Optical Co. recently enlarged their prescription department so that its capacity is now 1,000 per day.

A. T. Gillick, Midland, Mich., has moved his stock into a new brick store which was arranged with special reference to the needs of his business.

August Marwede, Alpena, Mich., recently remodeled his jewelry store and now has one of the best in that part of the State. He added a large wall case made for his cut glass, novelties and silver ware.

Down town jewelers enjoyed the first real taste of Winter and holiday trade last week, and business came with a rush. Out-of-town retailers also woke up and a large number of purchasers were seen among the jobbers.

On Dec. 12, 1889, Henry W. Simms lost \$700 worth of diamonds while he lay ill in the Central block, Bay City. They were brought there in the rough by George D. Sidman from South Africa, and Simms prepared them for sale by having them cut by a Chicago lapidary. Soon afterwards they disappeared. Last week, 10 years afterwards, a Bay City detective recovered them, but no prosecution will follow the discovery.

Adolph Enggass, one of Detroit's best known jewelers, last week filed a petition in bankruptcy and was adjudged a bankrupt. The liabilities as given are \$10,775; assets only \$260, and claimed to be exempt. Enggass has been in business here for 15 years and did a prosperous business when located at the lower end of Woodward Ave. About two years ago, however, he moved his stock into the store opposite J. L. Hudson on Gratiot Ave., and the location proved to be too obscure. Business fell off and Mr. Enggass says he recently reached the end of his rope.

**Indianapolis.**

Dec. 15 Enrique C. Miller returned from a two months' visit in Mexico.

James N. Mayhew, who two years ago sold out to Paul E. Haulsman, will re-enter the optical business on Massachusetts Ave. He will be ready for business Jan. 1, 1900.

All the retail stores are handsomely decorated with holly and laurel. One of

the daintiest Christmas windows is F. M. Herron's. An artistic use of holly and an exquisitely embroidered window curtain in holly sprigs make a background seldom equaled in beauty and appropriateness.

Holiday buyers in the city last week included: W. F. Kattman, Poland, Ind.; Charles Ham, Frankfort, Ind.; E. P. Houg, Paris, Ill.; A. Pursell, Noblesville, Ind.; Mr. Foust, of Foust & Young, Warren, Ind.; A. Hawkins, Noblesville, Ind.; E. A. Wiley, Mooresville, Ind.; H. Pauley, Bloomington, Ind.; J. W. Hays, Hillsboro, Ind.; Wm. Drake, Pendleton, Ind.

The beginning of 1900 will mark the birth of a new wholesale jewelry firm in this city, Sims & Lauer, 1024 Stevenson building. The firm will be composed of Charles Elliott Sims and Charles W. Lauer, both of whom have been connected with the firm of Heaton, Sims & Co. Mr. Lauer will represent the firm on the road and Mr. Sims will manage the office. They will start with an entirely new stock of jewelry—no watches—and will visit the trade in Indiana and Illinois.

**Minneapolis and St. Paul.**

A. L. Thompson, Mayville, N. D., who was burned out recently, as already reported, lost \$1,500; \$1,000 insurance.

L. J. Wilk, Minneapolis, has started an auction sale and will continue the same during the holidays. Sam Martin is conducting the sale.

Out-of-town jewelers visiting the Twin Cities on business the past week were: W. G. Gould, Glencoe, Minn.; William Nis-

bett, Grand Rapids, Minn.; M. Seewald, Harvey, N. D.; Fred Eickmeier, North Branch, Minn.

Charles Winter, of S. H. Clausin & Co., Minneapolis, on account of eye trouble will take a vacation for some time in order to go under proper treatment.

Alexander Sartor, San Antonio, Tex., has sold real estate for a consideration of \$500 cash and notes for \$900.

Mrs. Miles, wife of J. H. Miles, jeweler, Salt Lake City, Utah, who is wanted for embezzlement, has returned from a trip to Butte, Mont., where she is said to have gone in search of her husband, which, however, was unsuccessful. She found that the furniture and effects at her house had been attached by creditors of her husband on the supposition that both husband and wife had departed for good. On representations made by Mrs. Miles, the attachments were released. The Sheriff is sending out photographs and descriptions of Miles to various parts of the country in the hope of his identification and capture.

**G. F. WADSWORTH,  
Watch Case Manufacturer  
AND REPAIRER.**

Everything in the line of Watch Case Repairing. Old English and Swiss Cases changed to take American Stem-wind Movements a specialty.

**OLD CASES MADE NEW.  
CHARGES REASONABLE.**

Silversmiths' Building, CHICAGO.

**INTERNATIONAL SILVER CO.,**

Successor to

**The Holmes & Edwards Silver Co. <sup>AND</sup> The Barbour Silver Co.**

MANUFACTURERS OF

**SILVERWARE,**

SPoons, KNIVES, FORKS, LADLES AND HOLLOW-WARE.

**ST. LOUIS SALESROOMS:**

Holland Building, 209-211-213 North Seventh St.,

ST. LOUIS, MO.

**Georgian STERLING SILVER.**

In Complete Table Service—

French Gray Finish.



COFFEE SPOON.

**TOWLE MANUFACTURING CO.,**

CHICAGO.

NEWBURYPORT, MASS.



**THEODORE NEUHAUS & CO.,**

Lion Building, 5th and Elm Streets, CINCINNATI, OHIO.

SPECIAL WORK TO ORDER.

**Gold and Silver Smiths.**

MEDALS, BADGES, SCHOOL PINS, All Grades.

Repairing and Refinishing Given Special Attention.

### St. Louis.

Ed. Becker, Florissant, Mo., is now working for A. Unger, 4217 N. 20th St.

Edwin Massa, of the Bauman-Massa Jewelry Co., arrived home on the 15th from a southwestern trip.

Out-of-town jewelers here last week were: H. G. Knecht, Evansville, Ill.; H. W. Foerste, Okawville, Ill.; P. Zeigle, Nashville, Ill.; S. D. McPherron, Greenfield, Ill.; W. J. Sproul, Sparta, Ill.

One of the finest decorated stores in the business districts is that of Gerhard Eckhardt, 6th, near Olive Sts. An ever-green arcade reaching from the curb to the store entrance is a feature.

Frank Wendl, one of the old jewelers of this city, died on the 10th inst., aged 75 years. Up to five years ago he conducted a store at Market and 10th Sts., when he retired from active business. His funeral took place on the 12th inst., from his residence to the Missouri Crematory, where the remains were incinerated.

Charles L. Bates, diamond dealer, whom his wife, now in New York, charges with attempting to kidnap her son and wishing to place herself in an insane asylum, continues to deny the allegations made by his wife both in the complaint to the police captain and in her divorce suit which preceded the complaint. He now declares that he will contest the suit, as he is convinced that his wife was deceiving him regarding her intentions in going to New York.

### Pacific Northwest.

Johnson & Cyrus have removed their jewelry store to a new location in Prineville, Ore.

W. B. Clifton has accepted a position in Caldwell & Thom's jewelry store, Seattle, Wash.

J. P. Durfee, Shaw, Marion county, Ore., is preparing to establish a jewelry store at Lebanon, Ore.

F. C. Brodie has sold out his jewelry establishment at Goldendale, Wash., and will locate at Sumpter, where he will carry a stock of jewelry.

A. M. Goldman, Walla Walla, Wash., has received the order for silver ware for the dining room of Billings's Hall, the boys' dormitory of Whitman College.

J. H. Leyson, Butte, Mont., held his holiday opening last week, and had on exhibition a magnificent display of jewelry, cut glass, etc. Many souvenirs were distributed. The store was beautifully decorated for the occasion.

### Kansas City.

A. N. Gray has opened a new jewelry store at 309 W. 9th St.

Chas. Manor, auctioneer, is conducting a sale for Eugene Freeman.

W. H. Hudson, Winfield, Kan., passed through the city last week on his way home from an eastern trip.

All of the retail stores are now open evenings until after Xmas, and are having an exceptional rush of business.

Jaccard's have had almost more work in the stationery department the last few days than they have been able to do and have been obliged to run day and night

part of the time. There seems to be a greater demand for engraved invitations, monogram paper, etc., than there was for several previous holiday seasons.

Although diligent search has been made for the two diamond rings lost from the tray of diamonds which was stolen from J. B. Schmeltz recently, the gems have not been found, and it is supposed they were either swept away in the street cleaning or were picked up by some person not conscientious enough to return them.

A. F. Tucker left for the east Dec. 12, after spending two weeks here examining the city as a point for the manufacture of silver ware by the Tucker & Parkhurst Co., Ogdensburg, N. Y. Before going Mr. Tucker said: "In every way Kansas City has come up to what I expected. It is too early for a decision, but if we decide to come I shall be back in two or three weeks to arrange for one of the buildings I have looked over."

### Columbus, O.

#### TRADE CONDITIONS.

It looks very much like old times about the stores in this city now and it certainly seems so to the merchants in all lines of business. There is not one of them who is not doing a nice business and selling more goods than he has sold during a holiday season for many a year. For a time it seemed as if the trade was lagging and people were holding back for some reason, but now they are buying with a vim. The counters in all the stores were crowded from one end to the other with customers and all seemed to be looking for goods of superior quality. Reports from the smaller towns in the State are to the effect that the trade is good in all of them and that the dealers will realize the hopes which they have all along entertained in regard to the volume of business they will do this year. All of them will undoubtedly come out far ahead of any other season for many years.

The involuntary bankruptcy case of the Towle Mfg. Co. against Charles L. Hall, Gallipolis, has been passed in the United States Court and 10 days given to file papers which are required.

A fire occurred in the show window of jeweler H. L. Smith, late Saturday evening, which did quite a little damage to the stock on display. The draperies and holly with which the window was decorated became ignited from a gas jet, and in a moment the entire window was ablaze. There were watches, diamonds and other goods in the window which were damaged more or less, but Mr. Smith dragged the burning draperies from the window in time to keep the loss from being very large. In doing so he had his hands burned severely. The loss is estimated at about \$200.

Philip H. Bruck, former Mayor of Columbus and until recently receiver of the old Columbus Watch Co., made an assignment late Thursday evening to Nicholas Turner. The assets are placed at \$77,000 and the liabilities at between \$55,000 and \$60,000. Mr. Bruck said that there was about \$6,000 in claims pressing him and in order that no one should suffer he decided to make the assignment. He is interested in the New Columbus Watch Co., but this will not affect the company in any way. He was also interested in many other business enterprises in the city and had not these claims been pressed for payment at once he would have been able to meet them. He is almost prostrated over

the affair, although his property is ample to pay all claims and leave a nice balance.

### San Francisco.

A. H. Ewert, Ukiah, Cal., was in San Francisco last week replenishing his stock of holiday novelties.

Allan Marshall, manager of the watch department of Lundberg & Lee's new Post St. store, became the father of another son last week.

W. M. Gregory, formerly with the Occidental Watch Co., this city, is reported to be engaged in the hair dressing business at Redwood City, Cal.

Country buyers who were in San Francisco the past few days were: J. F. Schilling, Redding; C. H. Tully, Middletown, and L. C. Koberg, Healdsburg.

Jewelry exports from this port are steadily increasing. The chief demand comes from Hawaii, Japan and Manila. Last week seven packages were shipped to Japan and one to Manila.

F. F. Daunt, Merced, Cal., and Z. F. Vaughn, Tulare, Cal., were about the only representatives of the trade from San Joaquin Valley in San Francisco last week. They say that the recent rains will add largely to their holiday sales.

On Dec. 6 Detective Harper, of the San Francisco police force, arrested William Marvin and a woman who claims to be his wife, who are said to be jewelry thieves. When arrested Marvin was carrying a small grip, which was found to contain a quantity of jewelry which has not been satisfactorily accounted for. The two prisoners refused to be interviewed.

Mrs. Gertie Fiel, wife of I. Fiel, jewelry auctioneer, Oakland, Cal., was killed on the evening of Dec. 7 by falling or jumping from a third story window in that city. It is said that Fiel and his wife did not get along well together, and the officers suspect that it was a case of suicide following a quarrel. Mr. Fiel, however, denies this, and says that he was asleep at the time of the occurrence.

### Pacific Coast Notes.

The new jewelry establishment of J. H. Porter, Willow, Cal., has been opened.

Frank Six intends to open a jewelry business at Roswell, N. M., in the near future.

Victor Berta, Torro Creek, has purchased a watchmaker's and jeweler's stand in Santa Maria, Cal.

A creditors' dividend of 2.44 per cent has been declared on A. Wyatt, formerly jeweler at Salt Lake City, Utah.

C. C. Sullivan, accused of burglary in connection with the attempted robbery of A. O. Gott's jewelry store, Alameda, Cal., on Oct. 8, when Bert Willmore was killed, has given notice of an intention to move for a change of venue.

Capt. M. V. Bronson, Verdi, Nev., has moved with his family to Healdsburg, Cal., and will at once take charge of the work of developing the Cazadero onyx mine. The number of workmen in the quarry will be increased at once and the work of opening up the various veins pushed rapidly.



**WATCH CASE GUARANTEES.**

**THE RETAIL JEWELERS SPEAK OUT AND GIVE THEIR IDEAS ON AN IMPORTANT MATTER BEARING UPON THEIR TRADE.**

[This series of letters began in issue of Nov. 15.]

It was upon the request of several responsible jewelers that THE CIRCULAR entered upon the undertaking of obtaining a consensus of opinion from the retail trade regarding the guaranteeing of gold filled watch cases, and sent to a large number of jewelers, indiscriminately, a letter of which the following is a copy:

NEW YORK, Sept. 8, 1899.

WE ARE SENDING THIS LETTER TO THE RETAIL TRADE WITH THE OBJECT OF GETTING THEIR VIEWS ON AN IMPORTANT SUBJECT, NAMELY: THE GUARANTEEING OF FILLED WATCH CASES. FROM THE RESPONSES RECEIVED MAY BE EVOLVED SOME VALUABLE SUGGESTIONS.

OF THE FOLLOWING FORMS OF GUARANTEE, WHICH DO YOU CONSIDER MOST JUST, AND WHAT ARE YOUR ARGUMENTS ON THE SUBJECT?

1. SHOULD THE MANUFACTURER GIVE A NEW CASE OF THE SAME GUARANTEE IN EXCHANGE FOR THE OLD CASE THAT HAS NOT LIVED UP TO ITS GUARANTEE?

2. SHOULD THE MANUFACTURER EXCHANGE THE CASE THAT HAS NOT LIVED UP TO ITS GUARANTEE WITH ONE OF LOWER GUARANTEE? THAT IS, IF A 20-YEAR CASE HAS BECOME DEFECTIVE AT THE END OF 10 YEARS, SHOULD IT BE REPLACED WITH A 10-YEAR CASE?

3. SHOULD THE MANUFACTURER REPAIR THE CASE AND PUT IT IN CONDITION TO OUTLIVE THE UNEXPIRED TERM, IF THE CASE SHOWS THE BASE METAL BEFORE THE LIFE OF THE GUARANTEE HAS EXPIRED?

4. SHOULD HE GIVE A NEW CASE AND CHARGE FOR THE LENGTH OF TIME THE CASE THAT DID NOT LIVE UP TO ITS GUARANTEE HAS BEEN WORN; IN OTHER WORDS, REBATE FOR THE UNEXPIRED TERM OF GUARANTEE?

YOURS VERY TRULY,  
THE JEWELERS' CIRCULAR PUB. CO.

All those jewelers who did not receive this letter are cordially invited to send their views upon this subject, replying to the questions seriatim or collectively. Their replies will receive the same measure of consideration as those received direct from the letters themselves. The more views on this subject expressed by the trade at large the more convincing will be the conclusions reached.

[Sixth series of replies.]

WESTBROOK, Me., Sept. 13, 1899.

Editor of THE JEWELERS' CIRCULAR:

In reply to your favor of the 8th inst., just received, asking my views upon the subject of the guaranteeing of gold filled watch cases, I will say that to my mind the kind of settlement to be made by the manufacturer would depend much upon what portion of the time of the guarantee had expired; for instance, if only 10 years had expired under a 20 or 25 year guarantee, I would say the manufacturer should give a new case of the same quality. I don't believe in your second proposition, as I don't think a customer should be asked to accept a 10 karat case in place of a 14 karat one, as the 10 year cases are inferior in quality of the gold to the 20 year. If the first case has worn 15 or 18 years, then I would say that the manufacturer should repair the case and put it in condition to live out the unexpired term, as I believe the purchaser should have a

case that does not show the base metal for the guaranteed time without being obliged to make a new payment, as offered in your fourth proposition; if, however, the purchaser prefers a new case and will pay the difference, that would be an equitable way to settle the matter.

I shall be interested to know what the general opinion is on this subject. I am very truly yours,  
GEO. T. SPRINGER.

COSHOCTON, O., Sept. 13, 1899.

Editor of THE JEWELERS' CIRCULAR:

In reply to your letter of the 6th, in regard to guarantees on gold filled cases, my opinion is that No. 1 is the only subject for the retailer to consider. The manufacturer makes a case with a known amount of gold on it, he puts in the back of this a guarantee that it will wear for 20 years. If he is familiar with the details of his business he should know to almost a posi-

tive certainty how long gold of a certain thickness will wear, as he has had past experience enough to guide him in this direction by the number of cases returned. But he cannot expect to cheapen his product year after year and not also lessen his period of guarantee; one year he makes an 18 size case with 10 pennyweights of gold guaranteed for 20 years and the next the same size case and covers the same surface with three pennyweights of gold and then claims the same wearing quality as the former. By this method he is simply getting money for his product under false pretences and trusts to luck that he will not be called upon to make it good. If the manufacturer to-day cannot make a case guaranteed to wear for 20 years at the price it is sold for, then let him raise the price and the standard of his goods until they do fulfil the terms of the guarantee. If, after a customer pur-

**Another Victor.**

When the crucial test comes, when quality tells, side by side with the conquerors Olympia and Raleigh stands

**THE BOSTON.**



O size, 3 rows of pearls, made in Montauk, 20 years' guarantee, and 14 F.K., 25 years' guarantee.

**Joseph Fahys & Co.,**

Established 1857.

FAHYS BUILDING, NEW YORK.

chases a case and he is assured that the factory is thoroughly reliable, makes honest goods, has a great reputation, etc., he finds in three or four years that his case is worn through and has not lived up to the promises made by the retailer who sold it or the firm that made it, he feels that he has been imposed upon and that the retailer who sold the case knew that it would not do as represented, and if a new case is given in exchange it is accepted with doubt and misgivings by the customer, and, thenceforth, the retailer's guarantees are "taken with a grain of salt."

Then, again, there are instances where the value of a watch case is not purely intrinsic. It may be the gift of a mother, or

friend, who has gone to the great beyond and the gift cannot be replaced by a 10 year case to finish out the unexpired term of an unworthy predecessor.

Then the retailer is put to extra expense for mail or express charges in sending back cases to be exchanged. And if we let down the bars to the repairing or replacing of bogus 20 year cases by 10 year or plated and doctored imitations, the man that stands behind the retail counter can prepare to add largely to his expenses, and find that the word of fakir or street corner merchant is equal to that of the legitimate jeweler who has spent years in building up a reputation for honesty and integrity.

Give us honest goods, honest guaran-

tees, and the retail jewelers will do the rest. Yours very respectfully,

C. D. BROOKE.

BANGOR, Me., Sept. 13, 1899.

Editor of THE JEWELERS' CIRCULAR:

I. It seems unjust that the manufacturer should give an entirely new case (say a 20 year) after the case has been worn perhaps 15 or 18 years.

II. I don't think most of the owners would consent to accepting a lower quality case, although this would be a fair way.

III. I think it would be perfectly just to perhaps put a new back on a case if it was worn through and the other parts good.

IV. This is out of the question; nobody would consent to pay part cash.

I have been in business 25 years right here, long enough to see the practical working of gold filled cases. The best quality cases which I sold 16 and 18 years ago are wearing through in places. Cases with milled centers wear through in the highest places; a plain case wears longer than milling or sharp edges.

From what I have seen no case will be in use fully 20 years and not be worn through in some place or other. Therefore, the extension of the warrant from 20 to 25 years is a great mistake, and will make the retailers and manufacturers a great deal of trouble in time to come. It was furthermore uncalled for; everybody was satisfied with the 20 year warrant. I don't think it would have made any difference with the few manufacturers of first quality gold filled cases, even if the manufacturers of inferior cases had put a 25 year warrant into theirs, which the retailers would have known did not amount to anything.

I think the better way to warrant a case would be as to the amount of gold in the case, for instance:

x.....x		
:	This case	:
:	is warranted	:
:	to contain 5 dwt. 14 K. gold.	:
x.....x		

This would state an actual fact, nobody could get around it, and a careful man could make his case last 20 years perhaps, and a less careful one could not complain if it became worn through at the end of 15 years.

As it is, I hate to sell a case with a 25 year guarantee, because I know it won't wear that length of time.

ADOLF PFAFF.

ALLENTOWN, Pa., Dec. 1, 1899.

Editor of THE JEWELERS' CIRCULAR:

In reply to your questions regarding filled watch cases, we think if a 20 year case becomes defective at the end of 10 years or so it ought to be replaced with a new one of 20 years' guarantee. While the majority of customers will apparently be satisfied with another case that will outlive the unexpired term of years, yet a slight misconfidence has been created with the customer and he is very apt to buy or advise his friends to buy another make of case probably from some other dealer. We think the manufacturer ought to pay the penalty for this by giving an entirely new case with the original number of years' guarantee. This will restore confidence with the customer and be the very best advertisement for the maker of the case. Yours very truly,

FAUST & STERNER.

(Series of letters to be continued.)

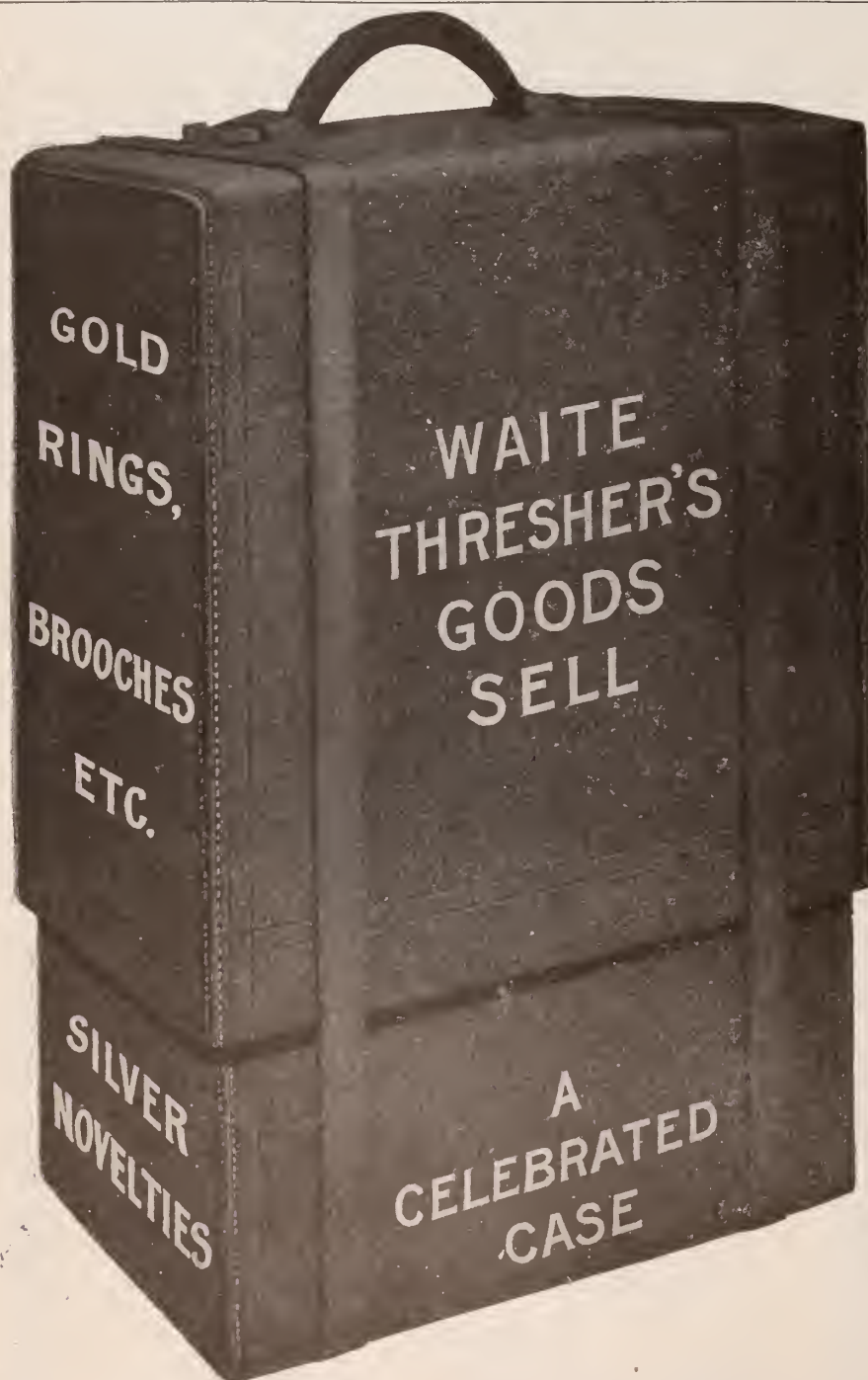

Remember that Articles Purchased from Samples Shown from the Above Celebrated Case are Quick Sellers at Popular Prices.

NEW YORK OFFICE, 11 John Street.

**The Latest Patents.**

ISSUE OF DEC. 12, 1899.

**638,727. FRAME FOR MEASURING SPECTACLES.** ALPHONSE J. LAUCH, Kankakee, Ill., assignor to Charles F. Whitmore, same place. Filed Nov. 26, 1898. Serial No. 697,511. (No model.)



In a spectacle-measuring frame provided with a nose-piece, a pair of measuring-arms separate from the nose-piece and pivotally attached at their outer ends to the nose-piece support, said arms adapted to be moved in and out in a plane at right angles to the face.

**638,745. DEVICE FOR ADJUSTING THE BEAT OF PENDULUM CLOCKS.** JOHN H. NEWELL, Lyndon, Kans. Filed Sept. 12, 1899. Serial No. 730,257. (No model.)

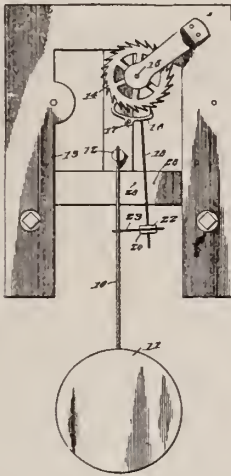

The combination with a verge-rod and a pendulum-rod of a clock-movement, of a beat-adjuster having two members frictionally engaging one with the other to travel together under normal conditions, and engaging with said pendulum and the verge-rod respectively.

**638,779. FOUNTAIN-PEN.** ARTHUR A. WATERMAN, Boston, Mass. Filed Aug. 16, 1899. Serial No. 727,347. (No model.)



An ink-feeder for a pen, the same consisting in a bar provided with a longitudinal groove extending along one side thereof, a divisional reed disposed longitudinally in said groove near the walls thereof and dividing the same into a comparatively narrow capillary subchamber beneath said reed, and an ink-supply duct above said reed of a comparatively large cross-sectional area, and a capillary passage extending along the side of said reed and connecting said subchamber with the said ink-supply duct, whereby said ink-supply duct is constantly maintained moist when the pen is not in use for quickly starting the flow of ink in said ink-supply duct when the pen is used.

**638,855. SOLDER FOR ALUMINIUM OR OTHER METALS.** CHARLES B. THWING, Galesburg, Ill. Filed April 17, 1899. Serial No. 713,395. (No specimens.)

As a solder for aluminium and other metals, an alloy of tin, bismuth and zinc, the tin being considerably in excess of the other metals.

**639,094. CUFF-BUTTON.** WALTER ROHRBEK, Yorktown Heights, N. Y. Filed April 13, 1899. Serial No. 712,847. (No model.)

A button composed of a base, a shank and an elastic head, the normal diameter of which is less than that of the base and practically the same as that of the shank, and means for compressing said

head to increase its diameter to exceed that of the shank, said means adapted to hold said head in



compressed position after it has been inserted through a buttonhole.

**639,110. TIME-CHECK MECHANISM.** JAMES J. STOCKALL, JR., London, England. Filed May 16, 1899. Serial No. 717,077. (No model.)

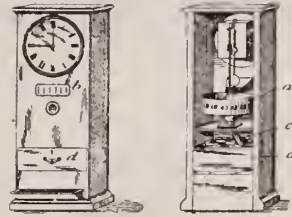

The combination with the subdivided tray, and the rotating spout, of a main timepiece having a pivoted, gravitating detent-lever *k* provided with two pendent detent-fingers *k'*, *k''* of different length, an auxiliary clock-work set in motion by the main timepiece, controlled by said detent-lever and geared with said rotating spout to control the motion thereof, a cam-disk *i* having a plurality of definitely-spaced-apart peripheral notches *i'* co-operating with the short detent-finger of said lever, a secondary cam-disk *j* having a plurality of definitely-spaced-apart peripheral notches *j'* co-operating with the long detent-finger of the detent-lever, said lever serving to accurately release and stop the auxiliary clockwork and the rotating spout thereof, an escapement-wheel *l* having pins *m*, *m'*, a pallet *o* co-operating with said pins to accurately stop and release the said escapement-wheel, auxiliary clockwork and rotating spout at predetermined periods of time, and means for revolving notched cam-disks at different speeds, the slow-revolving cam-disk controlling the detent-lever to prevent the action of the rotating spout during the intervals between the times when persons are required to deposit checks, and the fast-revolving cam-disk determining the fractional intervals of an hour at which said spout is set in motion.

**639,166. TIME LAMPLIGHTER.** JOSEPH FROSSARD, Porrentruy, Switzerland, assignor to Bernard Rund, Zurich, Switzerland. Filed Aug. 20, 1898. Serial No. 689,113. (No model.)

**639,177. WATCH-MOVEMENT BRIDGE.** JOSEPH L. KURTZ, New York, N. Y. Filed May 13, 1899. Serial No. 716,683. (No model.)

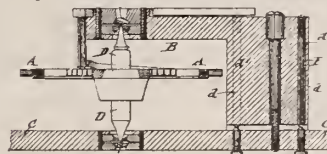

The combination, with the bridge of a watch-movement and its staff, of a fastening-screw attaching the rear end of the bridge to the bottom plate of the movement, and regulating screws arranged adjacent to said fastening-screw and formed of two sections each, one section being attached to the bottom plate and the other to the rear end of the bridge so as to retain the bridge in accurate position relatively to the staff in all temperatures.

DESIGN 31,964. MEDAL OR SIMILAR AR-



TICLE. WILLIAM VETTER, Cincinnati, O. Filed Nov. 6, 1899. Serial No. 736,047. Term of patent 3 1/2 years.

TRADEMARK 33,867. WATCHES. ELGIN NATIONAL WATCH Co., Chicago, Ill. Filed Nov. 20, 1899.



Essential feature.—The picture of a boy holding a watch. Used since Jan. 1, 1890.

**EXPIRED PATENTS.**

[Recently expired patents of interest to the jewelry trade. Reported especially for THE JEWELERS' CIRCULAR by R. W. Bishop, Patent Attorney, 728 Fifth St., N. E., Washington, D. C., who will furnish complete copies of patents at the rate of 10 cents each.]

[Issued Dec. 19, 1882.]

- 269,166. BRACELET.** J. M. BATES, Attleboro, Mass.
- 269,174. JEWELER'S DRILLING MACHINE.** W. S. BROWER, Albany, N. Y.
- 269,276 and 269,277. TABLE CUTLERY.** J. D. FRARY, Bridgeport, Conn.
- 269,278. CLOCKWORK ESCAPEMENT.** G. P. GANSTER, Reading, Pa.
- 269,290. PEN.** JOHN HOLLAND, Cincinnati, O.
- 269,383. EAR-KNOB.** JOHN CALDWELL, Providence, R. I., assignor to W. B. Bennett & Co., same place.
- 269,385. WATCH-REGULATOR.** D. W. CHALMERS, Springfield, Ill.
- 269,386. WATCH-CASE.** A. D. COE, Chicago, Ill.
- 269,428. WATCH-ESCAPEMENT.** JAMES KNEEN, 2d, Birmingham, and W. M. REED, Huntington, Conn.
- 269,446. HAND-VISE FOR BROOCH-PINS.** MYER MOSS, Yarmouth, Can.
- 269,450. STRIKING AND REPEATING MECHANISM FOR CLOCKS.** C. G. ORTH, and H. L. BRUGGEMAN, Cleveland, O.
- 269,475. ALARM APPARATUS FOR EIGHT-DAY CLOCKS.** W. D. SMITH, Pittsburgh, Pa. [Designs issued Dec. 20, 1892, for 7 years.]
- 22,059. SPOON.** G. U. ROULET, Toledo, O.
- 22,060. SPOON.** G. B. STOCKING, Tacoma, Wash.
- 22,061, 22,062, 22,063, 22,064, 22,065, 22,066, 22,067, and 22,068. SPOONS.** A. F. JACKSON, Taunton, Mass., assignor to the Reed & Barton Corporation, same place. [Designs issued June 16, 1896, for 3 1/2 years.]
- 25,632. BROOCHES, SCARF-PINS, Etc.** SAUL PRAGER, New York, N. Y.
- 25,636. HANDLES OF TABLE WARE.** P. O. DICKINSON, Newark, N. J.
- 25,637. NAPKIN-RING.** JOHN HASSELBRING, Brooklyn, N. Y.

**JULES J. LINTZ, Watch and Chronometer Maker**

**FOR THE TRADE.**

Two Diplomas and First Prizes for Scientific Workmanship.  
108 Fulton Street, New York.  
Downing Bldg., Room 1019.

Repairing of Fine and Complicated Watches  
Pocket and Marine Chronometers.  
All kinds of New Pieces made to order and adjusted.



**DEITSCH BROS.,**  
14 East 17th St.,  
New York.

**LEATHER. SHELL, EBONY, IVORY.**

# THE LADY RACINE

IS THE

## Best Chatelaine Watch

10 Line,  
11 Line,  
12 Line,  
13 Line,  
Hunting or  
Open Face,



Nickel,  
Steel,  
Silver,  
Enameled,  
Gold,

**In new and tasty designs.**

Can be ordered from all Reliable Jobbers.

**WM. H. BALL & Co.,**

**Our Specialty:**

MANUFACTURING JEWELERS,

Anderson Building, 12-14-16 John St., N. Y.



**Everything in  
Gold Bracelets.**

Curb Bracelets, Bangle Bracelets, Fancy Stone Bracelets, Baby Esther Bracelets, Bracelet Mountings.

**ALOIS KOHN & CO.,** SOLID GOLD CHAINS,  
4 MAIDEN LANE, Near Broadway, N. Y.

We call the attention of the Trade throughout the country to our line of

### LORGNETTE AND GUARD CHAINS.

Will send Samples on Memorandum on receipt of satisfactory reference. Correspondence Solicited.

**BONNER & CO.,**

Manufacturers of

**FINE DIAMOND MOUNTINGS,**

57 MAIDEN LANE, NEW YORK.



SAMPLE OF ENGRAVING DONE ON THE

**Eaton-Engle Engraving Machine.**

CATALOGUE AND SAMPLE OF WORK FREE.

**EATON & GLOVER** have removed to the **FULTON BUILDING,**  
87 NASSAU ST., Cor. Fulton, N. Y.

**ESSER & BARRY,** Largest Manufacturers of  
... Cheap and Medium Priced  
**IMITATION DIAMOND JEWELRY**  
IN AMERICA.

Write us for samples of almost anything with an Imitation Diamond in it.  
MAIN OFFICE AND FACTORY, 101 SABIN ST., PROVIDENCE, R. I.

### Workshop Notes.

**Metallic Varnish for Plaster.** — Tin, 1 part; mercury, 1 part, and bismuth, 1 part. Fuse the tin and the bismuth, then add the mercury to the two metals in fusion, stirring well so as to effect the combination. When this amalgam has cooled off reduce it into powder. For use, mix this powder with white of egg and apply on the plaster to be varnished.

**Gilding Steel.** — Pure gold is dissolved in aqua regia; the solution is allowed to evaporate until the acid in excess has gone. The precipitate is placed in clean water, 3 times the quantity of sulphuric acid is added and the whole left to stand for 24 hours in a well closed flask, until the ethereal gold solution floats on top. By moistening polished steel with the solution a very handsome gilding is obtained. By the application of designs with any desired varnish the appearance of a mixture of gold and steel may be imparted to the article.

**Cleaning Gold and Silver Lace, Etc.** — The lyes sometimes used are objectionable since they attack the color of the silk. Soap solutions are also injurious to certain colors. Spirit of wine is the best medium to renew the luster of the gold without injuring the silk, but if the gold is worn off much it causes the base metal to be too perceptible. For silver lace the following remedy is recommended: Take very finely powdered alabaster, lay the lace on a cloth and rub both sides by means of a soft brush and some of the powder until they are clean and bright. Then polish with another brush to remove all traces of the powder.

**Various Enamels for Precious Metals.**  
—*White:*—Crystal glass, 30 grammes; oxide of tin, 6 grammes; borax, 6 grammes; dioxide of arsenic, 2 grammes, or silicious sand, 50 grammes; powder consisting of 15 of tin per 100 of lead, 100 grammes; carbonate of potassium, 40 grammes. Fuse the whole with a quantity of manganese. To take away the accidental coloring pour it into water, and after having pulverized it, melt again three or four times.

*Transparent red:*—Purple of Cassius, 65 centigrammes; crystal glass, 30 grammes; borax, 4 grammes.

*Transparent blue:*—Crystal glass, 34 grammes; borax, 4 grammes; cobalt oxide, 4 grammes.

*Opaque blue:*—Crystal glass, 30 grammes; borax, 6 grammes; cobalt oxide, 4 grammes; calcined bone, 4 grammes; dioxide of arsenic, 2 grammes.

*Violet:*—Crystal glass, 30 grammes; borax, 4 grammes; dioxide of manganese, 4 grammes; cobalt oxide, 13 decigrammes.

*Transparent green:*—Crystal glass, 30 grammes; blue verditer, 4 grammes; borax, 2 grammes.

*Opaque green:* — Crystal glass, 30 grammes; borax, 8 grammes; blue verditer, 4 grammes; calcined bone, 4 grammes; dioxide of arsenic, 2 grammes.

*Black:*—Crystal glass, 30 grammes; borax, 8 grammes; oxide of copper, 4 grammes; oxide of iron, 3 grammes; oxide of cobalt, 4 grammes; oxide of manganese, 4 grammes.

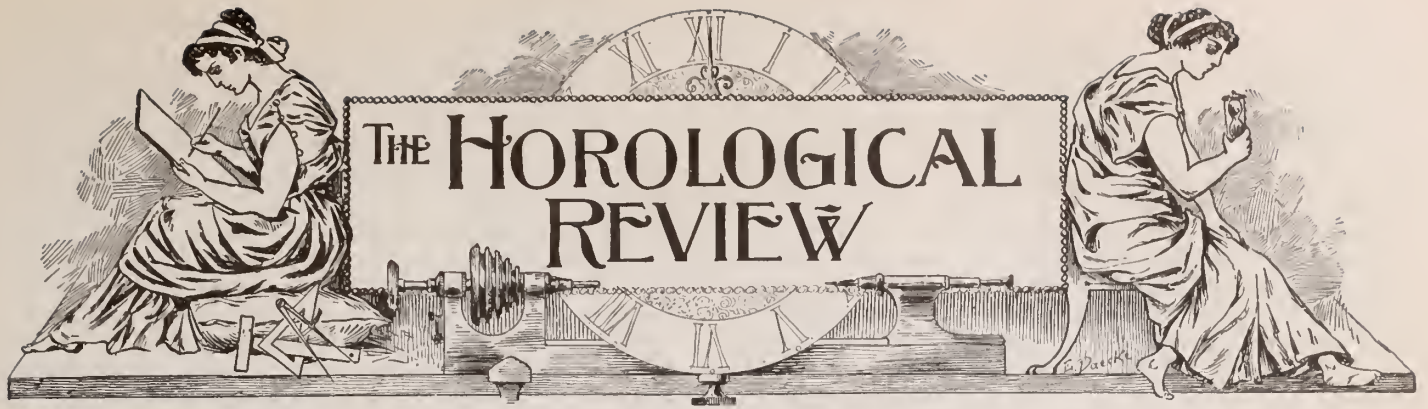

## PRACTICAL COURSE IN ADJUSTING.

### COMPRISING

*a review of the laws governing the motion of the balance and balance spring in watches and chronometers, and application of the principles deduced therefrom in the correction of variations of rate arising from want of isochronism, change of position and variation of temperature.*

### ELUCIDATED AND DEMONSTRATED BY

*original experimental researches in the actual problem, never before published, showing the causes that are operative in the variation of rate and leading to correct remedies.*

BY THEO. GRIBI.

Copyright by Theo. Gribi; assigned to THE JEWELERS' CIRCULAR PUB. CO.

[COMMENCED IN ISSUE OF FEB. 1, 1899. PART XXIII.]

## CHAPTER IV.

*(Continuation of Mechanical Effects.)*

The train of a watch must, of course, be perfectly free and the depth perfect, so that the transmission of the motive power should be effected under the most favorable conditions. To this intent the mainspring as the motive power merits our special attention. The main object to be accomplished is the development of the most uniform power during the interval of two successive windings. We have seen (12) that if we could limit the motion of the balance to a range between  $360^{\circ}$  and  $450^{\circ}$  the mean position error would be a minimum. In a mechanically perfect watch this can readily be accomplished by the choice of a proper mainspring and its fastening. This being a very important factor in adjusting, I shall consider it somewhat at length.

Some years ago I had occasion to pass upon the merits of a number of samples of mainsprings from different makers. I constructed an apparatus for measuring, by weight, the development of the force of a spring. I soon found that there was a great difference between springs of different makers and also between springs of the same maker, but differing in price. Among a great many I tested there were only two, the product of two different Swiss makers, that gave anything like a uniform development of force. The measurements were made for every eighth of a turn winding. One of the springs that gave the best result was a hookless one, *i. e.*, a spring that required no hook, sometimes called "slip spring," the outer end of which suddenly became thicker about eight and a half centimeters from the end, so that it braced itself against the wall of the barrel until wholly wound, when the strain produced by further winding caused it to slip. The other was a spring found only in the finest Swiss watches. The discrepancies in the development of the force of the springs led me to make a special inquiry as to the cause of it. I measured the thickness of some of them throughout their entire length for every centimeter distance. The spring which gave

the best result, one of the hookless ones, measured for the first eight centimeters from the outer end 0.32 of a millimeter. From that point it rapidly tapered down to 0.19 when about ten centimeters from the end. Then it continued at that until about twelve and a half centimeters from the inner end, when it again gradually increased in thickness until one centimeter from the end, where it measured 0.22 millimeters. The tapering at both ends, as well as the measuring between, was so uniform that it excited my admiration for the painstaking of the man who made it. The measurements of some of the other springs were very irregular, indicating no painstaking on the part of the maker. But I was not satisfied with this test. Desiring to watch the behavior of the springs in the barrel while being wound, I pierced the lid in form of the web of a wheel, which enabled me to look into the barrel at any stage of the winding. There appeared a marked difference in their behavior. While those which gave good results, and particularly the hookless one, wound in regular spirals around the arbor, the coils being more or less separated from each other during the winding, others, and particularly such as gave irregular results, fell to one side of the barrel immediately as I commenced winding them, pressing more or less heavily upon the arbor on one side and against the barrel wall on the other, the coils rubbing hard against each other and only becoming centered again during the last turn of winding. I soon discovered that this feature depended largely upon the manner of hooking the spring to the barrel wall. There was at that time a spring in the market used by one of the watch factories which had what was called a "punched hook," *i. e.*, the spring had at its outer end a tongue punched out which, being pressed outward, hooked into a notch milled into the barrel wall. This tongue would straighten out immediately upon commencing the winding of the spring and press the whole spring towards the opposite side of the barrel. All the springs with this hook gave very bad results in the development of their force; at some stage in their winding it was impossible to determine it, the addition or taking away of weight producing no appreciable difference in the indication of their force. The same was the case, though not quite so marked, with springs that had what is called the "T" hook. None of these springs would wind in concentric spirals around the arbor. The same factory that was using the spring with the "punched hook" had also a spring with what was called "a brace," but which, for reasons of economy, had been discarded. This brace consisted of an additional lamina riveted to the end of the spring just back of the hole, with a lip extending sideways through a notch in the lid, and a free tongue extending beyond the rivets in the direction of the spring. The lamina being riveted to the inside of the spring, this tongue acted as a reinforcement as far as it extended, holding the spring firmly against the wall of the barrel. Springs with this "brace" invariably gave better results as to the development of their force as

well as to winding concentrically; in fact, springs that had given very bad results with the punched hook would, on that being removed and the brace put in its place, give as good results as any of the ordinary springs. This experience led me to formulate a rule that, in order to obtain the best development of the force of a spring the outer end of it must be hooked solidly against the barrel wall. The method employed in some of the best foreign watches for holding the end of the spring to the wall by a lamina set inside of the first coil immediately beyond the hook and traversing both lid and bottom of barrel answers the purpose very well; but I believe that the "brace" is still better, inasmuch as the loose tongue of it

FIG. 28.

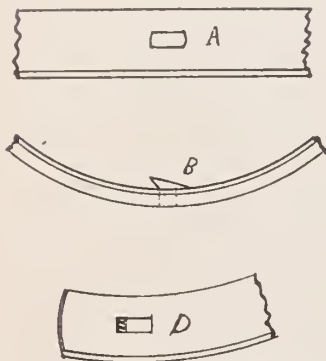
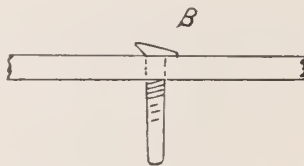

FIG. 29.



reinforces the spring and makes it wind more concentrically to the arbor. According to the experience with the hookless spring, there should be a tapering in thickness for a

short distance immediately back of the hook to increase its strength at that point and this condition the "brace" very nearly fulfills. A very good development of the force of springs can, however, be obtained without the use of the "brace" by properly hooking it in the ordinary way. This result depends wholly upon the manner in which the hook in the barrel and the hole in the spring are made, and for our guidance we need only consider some of the essential points of a good hooking. In the first place, the hook must be strong enough to resist all strain put upon it when the spring is fully wound. It should hold the end of the spring closely and tightly to the barrel wall. It should be as narrow as possible in order not to require too wide a hole in the spring, which

would weaken the latter at that point. A hook made in the old-fashioned way in the screw plate will serve the purpose well. If we make a hook, as shown in Fig. 28, A in plan and B in profile, and a corresponding hole in the spring D, we need not fear that it will ever break or allow the spring to slip. The undercut on the hook should be a trifle steeper than the slant bevel in the hole of the spring, for then the spring would take its hold at the very root of the hook, close to the barrel wall, and the greater the tension of the spring becomes the closer it will hug it. To make this hook, we select some hole in the screw plate—it need not be a large one, No. 9 of the Swiss plate will do for most watches—and having filed a piece of brass or nickel wire, tapering for a sufficient length to go through the hole free for a centimeter or a little more, we screw it into the hole until a full thread is formed on it. We then cut it off and hammer the large end down onto the plate as shown at B, Fig. 29, file up the front undercut for the catch and the sides, fitting the hook to the hole, previously punched into the spring and beveled, as shown at D, Fig. 28. It will be seen that the hook is made long and narrow and the back of it hammered down close onto the plate so as to act as a brace to it when screwed home against the barrel wall. To enable us to make the hook in the right direction on the wire so that when screwed home in the barrel it will stand just right, a trifling preliminary experiment is necessary—once for any given hole in the screw plate is sufficient if we make a note of it for future guidance: Screw a tapering piece of wire into the hole of the screw plate that is to be used. It is not necessary to form a full thread on it for the purpose. Cut it off, leaving a little of a projection on the large end, and on a level with the surface of the plate make an incision with a screw head file, on the side of the part that projects, noting the direction in which the incision stands with respect to the cardinal points of the screw plate; then remove it from the plate, screw it into the barrel from the inside and note the direction in which the incision stands in the barrel when flush with the wall. This will guide us as to the direction in which to make the hook on the plate, so that when it is screwed home in the barrel it will stand just right.

(To be continued.)

**Inclined Plane Clock.**

WHILE the clock on the inclined plane was invented by a Marquis of Worcester, as far back as 1661, we are today able to present to our readers one of very recent date, constructed in an especially pleasing frame by J. Podolski, of Wunstorf, Germany. The peculiarity of the clock on the inclined plane, says *Gesamte Uhren Industrie*, is that it works without a mainspring, while it rolls down the incline at a uniform, but hardly perceptible rate. While in the first clocks of this description the interesting phenomenon of the apparent absence of impulse was effected by a weight (lead semi-circle), which was situated on an arm connected with the hour wheel, this weight, or more correctly speaking, counter weight, is, in this construction, attached to the movement proper and the wheel carrying the hour hand is thus deprived of its character as chief or impulse wheel.

The cross section, fig. 2, of the clock movement of the later construction will suffice to disclose the details of its functions. In the center of the posterior wall *a* of the case, which is provided with finely

ribbed edges, we see a strong stud *b* on which the work frame proper is kept pivoted freely, but without any jamming, with its plates *c* and *d*, shoved by means of the protruding tube *e* and held by the aid of

depthing with this first wheel *g*, as is plainly shown in the sketch. It is obvious that a revolution of the movement proper around its axis or else a revolution of the fixed wheel *g* on this common axis must

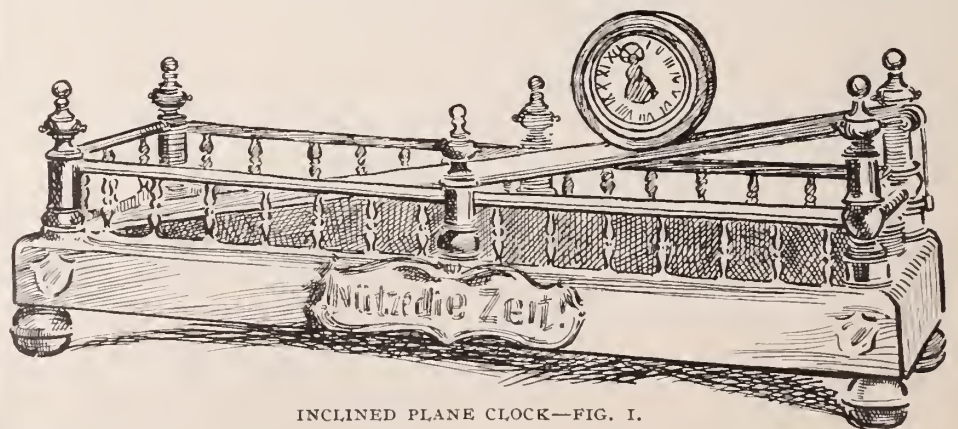

INCLINED PLANE CLOCK—FIG. I.

the screw *f* gearing with a groove of the stud. Concentrically to the stud *b* a wheel *g* is fastened by screws to the back *a* of the case upon three pillars riveted in. A pinion *h* of the movement proper stands in

start the movement, with which the pinion *h* is connected inside of the plates *c*, *d*, as soon as the movement proper is prevented by a one-sided weighting, to also revolve freely upon the stud *b*. Such a rotation of

the fixed wheel takes place *eo ipso*, when the case is started into a rolling motion on an inclined plane.

To this rotation, however, to prevent its being completed in a moment, a resistance must be offered by a counter weight. This must be movable and so arranged that it is independent of the rolling case. While, as said before, this counter weight, in the

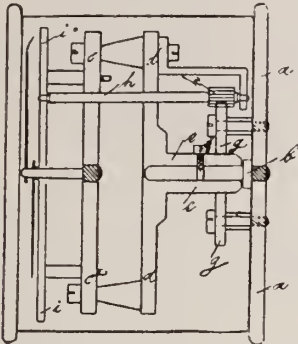

FIG. 2.

original construction, was fixed to the hour wheel, it is here fastened to the movement proper. The clock case, owing to its weight, gravitating downward, but being prevented from rolling down by the counter weight, which, of course, must be in a certain proportion to the weight of the case, this counter weight, which is marked



FIG. 3.

by dotted lines in fig. 3, showing the dial side of the clock, by having a tendency to turn the movement and with it the pinion *h* (fig. 2) around the fixed wheel *g*, exerts a pressure upon the train and the escapement, which starts the clock. In consequence of the possibility of a descent of

the impelling counter weight by reason of the advancing motion of the wheels, an equalization is again made room for, inasmuch as the counter weight by a slight descent of the case on the inclined plane reobtains its original position. Naturally these movements, the sinking of the counter weight and the rolling of the case, occur in such a small measure that they are hardly perceptible to the eye of the observer, and the dial, which is firmly united with the movement, never changes its vertical position (XII up). As regards the slope of the inclined plane this is dependent upon the frictional proportions between the materials of which the plane and the case are made. If the plane were continually made steeper without regard to this frictional proportion, the work would finally lose its balance, rendering the counter weight ineffective, and the whole would turn a somersault and dart down the incline. In Podolski's construction the inclined plane consists of slate, while the case has ribbed edges. This edging will have to be very fine and uniform, if the intended advantage, viz., to prevent the work from slipping, is not to change into a drawback by the clock rolling down by fits and starts.

As regards the composition of the train, we cannot give the reader any information, owing to the lack of data. But this need not be regarded as a drawback, since thus everybody is free to construct as he pleases without following his predecessors. As is shown by fig. 3, the work of Podol-

ski's clock has a visible anchor escapement and fly seconds, both of which are valuable for their effect upon the public, though perhaps less favorable for a convenient reading of the time.

The inclined plane can be set by means of a nut situate at the right side of the frame. On the same side we see in fig. 1 a lead, which, attached above a fine sight-point, may be used for an accurate leveling of the frame. For this purpose the feet of the stand are provided with screwable brass insertions.

Some data regarding the outside proportions may be of value. The length of the stand is 50 cm., the breadth 18 cm., the length of the track 47 cm. and the diameter of the case 7 cm. Consequently, the latter would in the most favorable case be able

$$\text{to make } \frac{47}{7 \times 3.14} = 2.13 \text{ revolutions on the inclined plane.}$$

The clock case, however, touches the gallery already 3.5 cm. before the end of the run, hence is prevented from

$$\text{making more than } \frac{43.5}{7 \times 3.14} = 1.98 \text{ revolutions.}$$

The wheel *g* fastened to the back of the case (fig. 2) having 84 teeth and the pinion *h* engaging with it having 6 leaves, the clock, since this pinion accomplishes the functions of the center pinion and is connected between the plate *c* and *d* with the train and between plate *c* and the dial *i* with the motion work, will have run 14 hours with each revolution of the case, hence its whole running period will be at most  $14 \times 1.98 = 27$  hours 43 minutes.

## JULES JÜRGENSEN,

COPENHAGEN,

Plain and Complicated **WATCHES AND CHRONOMETERS,**

Are the leading production of their kind in the world.

SOLE AGENTS

# Schulz & Rudolph,

*Importers and Cutters of Diamonds and Other Precious Stones....*

**28 JOHN and 65 NASSAU ST., NEW YORK.**

## THE TRUE BLUE

Beaded Label Watch Glasses,

MADE IN

# FRANCE.

ASK YOUR JOBBER FOR THEM.

**SUSSFELD, LORSCH & CO.,**

21 Rue de L'Echiquier, PARIS.

LORSCH BUILDING,  
37 & 39 Maiden Lane, NEW YORK.



## WATCH GLASSES

BEAR THE BEADED LABEL.

BEWARE OF IMITATIONS.

THE GENUINE ARE LABELED



# FRANCE.

# BRADLEY & HUBBARD MFG. CO.

Have produced for this season's trade  
the finest line of goods ever offered.

## Art Metal Goods,

PITCHERS, VASES, CANDELABRAS,  
FIGURES, BUSTS, TABLES, ETC.....

## Reception Lamps

WITH THE CELEBRATED "B. & H." and B. & H. RADIANT BURNERS.  
NEW AND ORIGINAL DESIGNS.  
HANDSOME AND EXCLUSIVE FINISHES.

*Dealers are cordially invited to inspect the line of Samples  
at our SALESROOMS.*

NEW YORK: 26 Park Place to 21 Barclay Street.

BOSTON:  
160 Congress Street.

CHICAGO:  
131 Wabash Avenue.

PHILADELPHIA:  
714 Betz Building.

FACTORIES and OFFICES: MERIDEN, CONN.

## SILVER MEDAL AWARDED

... BY ...

NATIONAL EXPORT EXPOSITION, Philadelphia,

... TO ...



**C. F. Rumpp & Sons,** Established 1850.

PHILADELPHIA,  
FOR

HAND-CARVED LEATHER GOODS.

SEND FOR ILLUSTRATED CATALOGUE.

## PATEK, PHILIPPE & CO., GENEVA, SWITZERLAND,

MAKERS IN THE HIGHEST QUALITY OF

**Fine, Plain, Complicated  
And Decorated Watches**

IN 15 DIFFERENT SIZES.

INTERCHANGEABLE PARTS.

NEW YORK OFFICE, 68 NASSAU ST.

ALFRED G. STEIN, Representative.

**WM. SMITH & CO.,** GILL BLDG., 9-13 MAIDEN LANE, N.Y.  
61 PECK ST., PROVIDENCE, R. I.

ESTABLISHED  
1854.

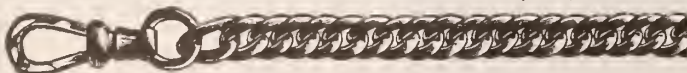

MANUFACTURERS  
OF

**Gold, Silver and Rolled Plate Chains and Jewelry.**

Novelties in Gold and Silver Bracelets. Also a large line of Chain Trimmings.



GOLD SHELL.

*"Buy direct from the manufacturer and get  
all that is coming to you."*

SEND FOR OUR "HOT CATALOGUE, CONTAINING  
COLD FACTS AND PRETTY PICTURES."

**CLARK & COOMBS,**

86 WEST EXCHANGE ST., - PROVIDENCE, R. I.

WE ARE  
HEADQUARTERS  
FOR.....

**Gold  
Shell  
Rings...**

## THE SWAN FOUNTAIN PEN.

Reputation World Wide.  
Made upon Distinct Principles.  
Is a Compressed Air Pump.  
Simply Wet the Insides to Provoke  
an Energy.

**W. W. Stewart,** Inventor and Patentee.

A variety of Styles and Prices

3 Sizes Safety Swans.

3 Sizes Self-filling Swans.

3 Sizes Adjustable Feed Swans.

## MABIE, TODD & BARD,

NEW YORK AND LONDON.

## HENRY C. HASKELL,

11 Maiden Lane, N. Y.,

has a special department for Jewelry  
repairing of all kinds. Prompt  
attention. Prices right. Exclusive  
Design Plates sent dealers upon  
request.

## DR. KNOWLES'

...PRIVATE COURSE IN...

## Optometry.

SPECIAL RATES IN THE  
CORRESPONDENCE DEPARTMENT.

"EYE DEFECTS,"

A New Book, in cloth, Price, \$1.00.

For terms and important particulars, write to  
**R. H. KNOWLES, M. D.,**  
36 John Street, New York.

WOOD  
ENGRAVINGS.



TELEPHONE, 645 JOHN.

## FERD. FUCHS & BROS., SILVERSMITHS,

MAKERS OF STERLING SILVERWARE,  
34 East 29th St., - New York.

## WOOD & HUGHES,

Sterling Silverware Manufacturers,  
FINE PLATED WARE,  
No. 24 John Street, - New York.





## THE RAMBLER'S NOTES.

WHAT THE RAMBLER SAW AND HEARD AMONG THE DEALERS IN ART POTTERY, CUT GLASS, BRONZES, ETC.

ONE of the many lines in which Bawo & Dotter, 26-32 Barclay St., New York, are offering special holiday assortments is the famous Wedgwood jasper ware that has been sold by jewelers for so many years. These beautiful pieces with their artistic cameo decorations seem to never lose favor with the buyers of fine ceramics, but grow in popularity year by year. The stock carried by this firm is one of the largest to be found in the country, so they are, therefore, enabled to make up special assortments to suit all kinds of trade. These assortments include not only the standard articles of the ware, but also many others in shapes and styles controlled exclusively by Bawo & Dotter. The prevailing body colors now are dark blue, olive and sage green and the assortments include all three, two or a single color, as the dealer may desire.

FINE LAMPS FOR HOLIDAY TRADE.

THE Christmas season always brings forth a demand for fine lamps,

which jewelers have found is adequately filled by the productions of the Bradley & Hubbard Mfg. Co., Meriden, Conn., and this season is no exception to the rule. The line of "B. & H." lamps which this company are offering at their salesroom, 21 Barclay St. and 26 Park Pl., New York, is now not only the finest they have ever made, but is also one of the largest and richest in assortment and variety ever offered to the trade. All styles and shapes of lamps, from the largest banquet to the smallest princess sizes, are here to be found in the company's many original and exclusive designs and finishes, which have been mentioned in this column from time to time.

\* A FORERUNNER of the lines which the J. B. Owens Pottery Co.

expect to introduce during the next year is now to be seen at their New York salesrooms, 68 West Broadway. In this latest variety of American pottery the designers have drawn their effects from the Japanese, while still holding to the brown, yellow and ox-blood red colorings which they have

so successfully used in the former lines. The style of the ware is denoted in its name "American Awaja," and shows the conventional scroll and flower decorations of the Japanese in a rich underglaze effect. The line now contains a large collection of vases, urns, pitchers and similar pieces, in large and small sizes, and will soon include all the articles heretofore made by this company.

THE RAMBLER.

## Increased Prices of American Pottery.

THE manufacturing potters of the west, including representatives from Wheeling, Cincinnati, Akron, Steubenville and East Liverpool, have just closed an important meeting in East Liverpool, O. It was decided to make an additional increase of 5 per cent in the price of ware, making an advance of 10 per cent in the last 75 days. The new schedule will go into effect about Jan. 1. This increase will virtually bring the prices up to the scale adopted at the meeting held in January, 1898, and in some cases the increase to the lists will amount to about 20 per cent.

During the past year the prices of material have advanced from 2 to 17 per cent, as will be seen by the following: Cobalt, from \$1.76 to \$2 a pound; spar, increased \$1.50 a ton; lead, from 4½ to 5¾ cents a pound; zinc, from 5¼ to 7¾ cents a pound; acids, from 8 to 10 cents a pound.

## Jewels Aforetime and Jewels of To-day.

FASHION in jewelry seems to return to chasings of gold. The history of jewelry, like the history of all sublunary things, is filled with alternations, which have been set forth by a Parisian goldsmith in a comparison entitled: "Jewels Aforetime and Jewels of To-day."

The first collection in France which received the designation of jewels of the Crown was made by Francis I., consisting principally of the jewelry which his queen, Claudia, had inherited from her mother, Anne de Bretagne. Later, Catherine de Medicis brought in Italian styles, but neglected no occasion to employ French or Flemish artists and took pains to promote the love of luxury at the court of her sons. After the time of the Valois the taste for beautiful adornment experienced an eclipse in France and jewels were pledged for the payment of the troops.

In the reign of Louis XIV. jewelry attained its zenith. The Grand Monarch

doted on precious stones; diamonds were displayed everywhere, and stones were set in masterpieces of chased gold. The king excited a display before unheard of and caused his courtiers to adorn themselves as he did, which extravagance resulted in their ruin. Mazarin, himself, was very fond of gems, especially for their value, and left some that were truly superb. After the death of Louis XIV. came the regency, and it is curious to observe that at the commencement of this era of pleasure and debauch, great efforts were made to restrict expenditures by the community. The declaration of Feb. 4, 1720, forbade the wearing of diamonds, pearls and other gems. Little account was taken of it, and such severity on the part of the regent could not last. In 1721 a new ordinance authorized the making of gold jewelry and small articles, such as snuff boxes, caskets, etc., whose weight did not exceed seven ounces.

Under Louis XV. the style of jewelry, as well as that of furniture and architecture, passed to an odd mixture of cunning devices and pastoral designs, with an inclination to the antique due to the discoveries at Pompeii. At the close of the reign of Louis XVI., on the eve of the great breaking up, French society, elegant, witty, unthinking, lived on in festivals and entertainments, while affecting a sort of simplicity and a regard for the natural. Men put off their beautiful, graceful costumes of silk and lace and began to wear cloth, and in general adopted English fashions. Gems and jewels were concealed during the revolutionary tempest, but reappeared under the empire.

It is remarkable that the finest jewelry has passed to America. It is North America that has absorbed the largest and most splendid diamonds. The Savoy and the most important of the Mazarins are in American hands; but the magnificent African diamond, the stone of 180 karats, which was exhibited at the Paris Exposition of 1889, has become the property of a rajah of India.

E. A. Arenburg, Portage, Wis., will remove to another location in that town about Jan. 1.

In the home of M. S. Wadsworth, Prattville, Ala., is a pitcher that has been in constant use 110 years, being a bridal present to Isaac Dickinson and Miss Pollie Tyos, shortly after the Revolutionary war. The family has also a salt cellar and a plate used since 1818 and a large dish 65 years in use.

**Tiffany & Co.**  
 Christmas Greeting

The many Christmas purchases already made and held for future delivery, prompt us to again remind patrons that they will consult their own interests by making early selections, while the stock is rich with many choice and dainty objects that cannot be duplicated later.

UNION SQUARE  
 NEW YORK

**Tiffany & Co.**  
 Holiday Announcement

Owing to the unusual number of orders for jewelry and silverware, Tiffany & Co. advise their patrons desiring special products for the holidays, that to avoid disappointment, it is absolutely necessary to place their orders without delay.

**Tiffany & Co.,**  
 UNION SQUARE  
 NEW YORK

**Tiffany & Co.**  
 Clocks and Bronzes

Traveling clocks, \$12 upward with alarm, \$14 upward.  
 Marble mantel clocks, \$15, \$16, \$20 upward.  
 Hall clocks, in mahogany or oak cases, \$120 upward with chimes, \$200 upward.  
 Bronze statuettes, with electric lights, \$55, \$70, \$90 upward.  
 Bronze busts for cabinets, \$4, \$5, \$6 upward.  
 Bronze statuettes for cabinets, \$8, \$14, \$15 upward.

**Tiffany & Co.,**  
 UNION SQUARE  
 NEW YORK

*In 45 Days*  
**1900.**

*In 38 Days*  
**Xmas.**

To correct a widespread misapprehension as to Fifth Avenue prices we would state that in all the great variety of Jewelry and Solid Silver there is no place where it can be bought to better advantage. If intending purchasers would only look and compare for themselves they would soon find it out. Of course those that are wide awake and up to date, know this already, but prejudice, which keeps many away, would, if once overcome, demonstrate the great advantage of large assortment, new patterns and prices absolutely no higher than elsewhere, with quality beyond question.

**Howard & Co**  
 264 Fifth Avenue

*In 31 Days*  
**1900.**

*In 24 Days*  
**Xmas.**

A necklace in which every pearl is perfectly round, free from imperfections, all the same color and that the best, is most difficult to obtain, especially if of any large size. We have one of this description which graduates from a centre of 22 grains, which will bear the most critical examination.

**PRICE \$36,000.**

All our pearls were secured before the recent great advance in price abroad, and our retail prices are very much less than similar goods cost now to first hands in London or Paris.

**Howard & Co**  
 264 Fifth Avenue

*In 41 Days*  
**1900.**

*In 34 Days*  
**Xmas.**

A remarkable large Marquise shape

**Pink Diamond**  
 with a superb

**Canary Diamond Drop**

Exquisite contrasting colors. Set together as Brooch or pendant

**PRICE \$18,000.**

**Howard & Co**  
 264 Fifth Avenue

*In 24 Days*  
**1900.**

*In 17 Days*  
**Xmas.**

The peculiar attraction of our Silverware is that it differs entirely from the usual. Selections of the very best patterns from all sources, domestic and foreign, make it unlike the productions of any single factory, where ideas naturally run in a groove. Everything is substantial and in good taste, excessive ornamentation is avoided, and there is more variety than can be found elsewhere. Examination and comparison will convince that prices are even lower than the cost of inferior goods.

(No plated ware whatever.)

**Howard & Co**  
 264 Fifth Avenue

**A.A. Webster & Co.**  
 460 FULTON ST., BROOKLYN.

**Holiday Gifts.**

The holiday to many a Christmas gift is that it is inappropriate. Give your friends something they'll use. We suggest these from our new holiday goods:

**FOR WOMEN:** **FOR MEN:**

For Boxes, Perfumers' Thermometer Cases, Cologne Bottles, Traveling Medicine Cases, Atomizers, Cigarette Cases, Chain Purse, Cork Straps, Combination Pocket Smokers' Sets, Soap, Paper Knives, Chain Chatelaine Bags, Paper Weights, Lognettes, Shaving Mugs, Mantel & Sps., Cover Gases, Opera Glasses, Cigar Cases, Toilet Cases, Tobacco Boxes, Military Brushes, Comb and Brush Trays, Pipes of all kinds.

There'd be no period to these lists if we didn't cut it short somewhere. Looking at the articles themselves is better than all the mentionings we could give here.

**WILLIAM WISE & SON,**  
 Jewelers.

An unusually busy December makes an early selection advisable.

Flatbush Av and Fulton St.

**A Successful Jewelry Exhibit.**

It will strike the cultivated observer that in making up our present exhibit of jewelry and precious stones, we have been quite as successful in the selections as in the selections. The commonplace has been excluded. From the most inexpensive article to the costliest, each object is worthy of more than passing notice.

**GATTLE,**  
 27th Street and Broadway.

**Theodore A. Kohn & Son,**  
 JEWELERS,  
 56 West 23d Street.

Invite your inspection of their choice stock of

**Fine Diamond Jewelry.**

**Sleeve Buttons.**

We direct especial attention to our assortment of Diamond Link Sleeve Buttons.

Dumb-bell Buttons, . . . \$3.00 to 11.00  
 Etruscan Link Buttons, . . . \$4.50 to 13.00  
 Amethyst Link Buttons, . . . \$4.50 to 14.00  
 Enamelled Link Buttons, . . . \$6.00 to 75.00  
 Diamond Link Buttons, . . . \$7.50 to 100.00

**Theodore A. Kohn & Son**  
 JEWELERS  
 56 West 23d Street

# American Watch Case Co.,

**A.W.C.CO**

9-11-13 Maiden Lane,

Gill Building, New York.

## CROUCH & FITZGERALD,



Jewelry Trunks and Cases,  
161 Broadway,  
Bet. Cortlandt and Liberty Sts.  
688 B'way,  
723 6th Av.  
NEW YORK.

## THE LEDOS MFG. CO.,

MANUFACTURERS OF

## Watch Case Materials,

Crowns, Pendants, Bows, Solders, Springs, Findings, Etc.,

34-36 PEARL ST., NEWARK, N. J.



**SIMONS BROS. & CO.**  
PHILA. NEW YORK CHICAGO  
SILVERSMITHS, JEWELERS.  
MAKERS OF GOLD AND SILVER THIMBLES.

## JACOT & SON, IMPORTERS.

**STELLA AND IDEAL MUSIC BOXES.**

39 UNION SQUARE, - N. Y.

**H. M. RICH & CO.,**  
**Jewelry - Auctioneers,**  
7 and 9 Franklin St.,  
BOSTON, MASS.

# Push-Grit-Energy.

A long time ago we concluded that the only way to succeed was by practicing **Push**, showing **Grit** and never diminishing **Energy**. The result is shown in our

## 1900 Line of Jewelers' Findings

THEY INCLUDE

TUBE SETTINGS FOR COMBS, EBONY MOUNTS, PATENT CLUSTER SETTINGS.

## MEDALLION HEADS

FOR BROOCH PINS, BELT BUCKLES, LINK BUTTONS, ETC.

Large Scrolls for Picture Decorations and everything in Findings for the Manufacturer.

# HEIMBERGER & LIND,

158 PINE ST., METCALF BUILDING, PROVIDENCE, R. I.

"BY USING OUR GOODS, YOUR GOODS WILL SELL."

## KETCHAM & McDOUGALL,

MANUFACTURERS OF

GOLD AND SILVER

## THIMBLES

ESTABLISHED 1832.

**M&D**

TRADE-MARK.

And the improved

Automatic Eye-Glass Reel.



No. 149



Pat'd Nov. 30, '94

SEND FOR CATALOGUE C.

37 MAIDEN LANE,

NEW YORK.

## AIKIN, LAMBERT & CO.,

MANUFACTURERS OF

FINE GOLD PENS, HOLDERS, PENCILS, TOOTH PICKS and NOVELTIES.

PAUL E. WIRT FOUNTAIN PENS, at new and lower prices . . .  
MERCANTILE FOUNTAIN PENS, guaranteed to give satisfaction.

Catalogues with terms and discounts furnished to the trade.

BRANCH, 103 STATE STREET, - - - CHICAGO.

19 MAIDEN LANE, NEW YORK.

## AIKIN-LAMBERT JEWELRY CO.,

IMPORTERS OF

## DIAMONDS.

JOBBER IN

WATCHES, JEWELRY, CHAINS, NOVELTIES, ETC.

LATEST DESIGNS.

LOWEST PRICES.

# CHAS. F. WOOD & CO., DIAMONDS

1 MAIDEN LANE, NEW YORK.

IMPORTERS AND CUTTERS.

## DIAMONDS.

LARGE ASSORTMENTS.

DESIRABLE SIZES.

ATTRACTIVE PRICES.

**R., L. & M. FRIEDLANDER,**

30 MAIDEN LANE, N. Y.

97 HATTON GARDEN, LONDON.

## HALL CLOCKS,

*Mantel Clocks,  
Traveling  
Clocks,  
Clock Sets,  
Regulators,  
Bronzes,  
Vases, Ivory  
Miniatures  
and Art Goods.*



Fall Line Now Ready.

**Harris & Harrington,**

32 and 34 VESEY ST., NEW YORK.

Sole Agents to the Trade for J. J. Elliott & Co., London.

Survival of the Fittest.

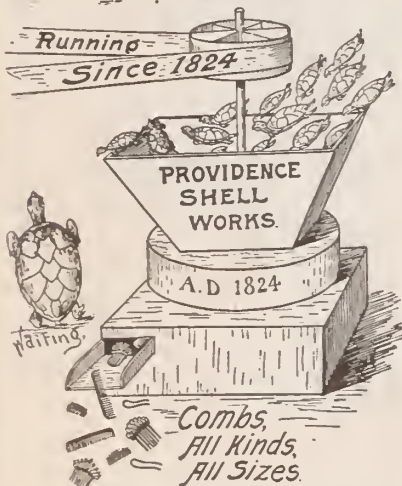

POTTER'S COMB FACTORY,  
PROVIDENCE, R. I.

We Grind for You,  
Send along your Work.

**W. C. A. WESTPHAL,**  
WATCHMAKER,

41 Maiden Lane, NEW YORK.

Established 1892. Telephone, 3684 Cortlandt.  
Estimates, Repairing, Adjusting of Chronometers, all  
Complicated Watches and Fine Time Pieces.

DEMAGNETIZING.

Watches made Non-Magnetic.  
Fine Wheel and Pinion Cutting

## HOROLOGICAL DEPARTMENT,

BRADLEY POLYTECHNIC INSTITUTE,  
PEORIA, ILLINOIS.

Largest and best watch school in America. We teach  
Watch Work, Jewelry, Engraving, Clock Work,  
Optics. (Formerly Parsons' Horological Institute.)  
Catalogue Free.



GOLD AND SILVER PENCILS,  
PENHOLDERS, &c.



FAIRCHILD & JOHNSON CO.

Office and Factory,  
220 FOURTH AVENUE, N. Y.

## L. LELONG & BRO.,

Gold and Silver

Southwest Corner of  
HALSEY and MARSHALL STREETS,

REFINERS,

NEWARK, N. J.

ASSAYERS and

Sweepings a Specialty.

SWEEP SMELTERS.

## Horseshoe, Clover, Heart, Wishbone and Anchor.

THESE ARE A FEW OF THE THOUSAND  
DIFFERENT DESIGNS OF LUCKY BANGLES.

**S. & B. LEDERER CO.**

FACTORY: 100 STEWART STREET,  
PROVIDENCE, R. I.

New York Office, 11 John Street.

Chicago Office, 131 Wabash Avenue.

ALBERT LORSCH.

TELEPHONE CALL, 746 CORTLANDT, N. Y.

ALFRED KROWER

## ALBERT LORSCH & Co.,

LORSCH BUILDING,  
37 & 39 MAIDEN LANE, N. Y.,

167 WEYBOSSET ST.,  
PROVIDENCE, R. I.

IN STOCK, A LARGE ASSORTMENT OF

# PEARLS

ALL SIZES AND  
QUALITIES.

**PROV. STOCK CO.** HIGH GRADE ROLLED PLATE  
Chains

10K. GOLD

Scarf Pins, Brooches,  
Neck Chains, Lorgnettes,  
Bracelets.

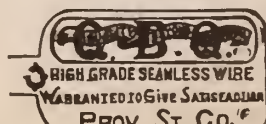

40 Stewart St., PROV., R. I. 11 John St., N. Y. Silversmiths' Bldg., CHICAGO.

BRACELETS, LORGNETTES.

Arnstein Bros. & Co. AND CUTTERS OF Diamonds

DIAMONDS and Cutters. L. & M. KAHN & CO., 172 Broadway, COR. MAIDEN LANE, N. Y., DIAMONDS

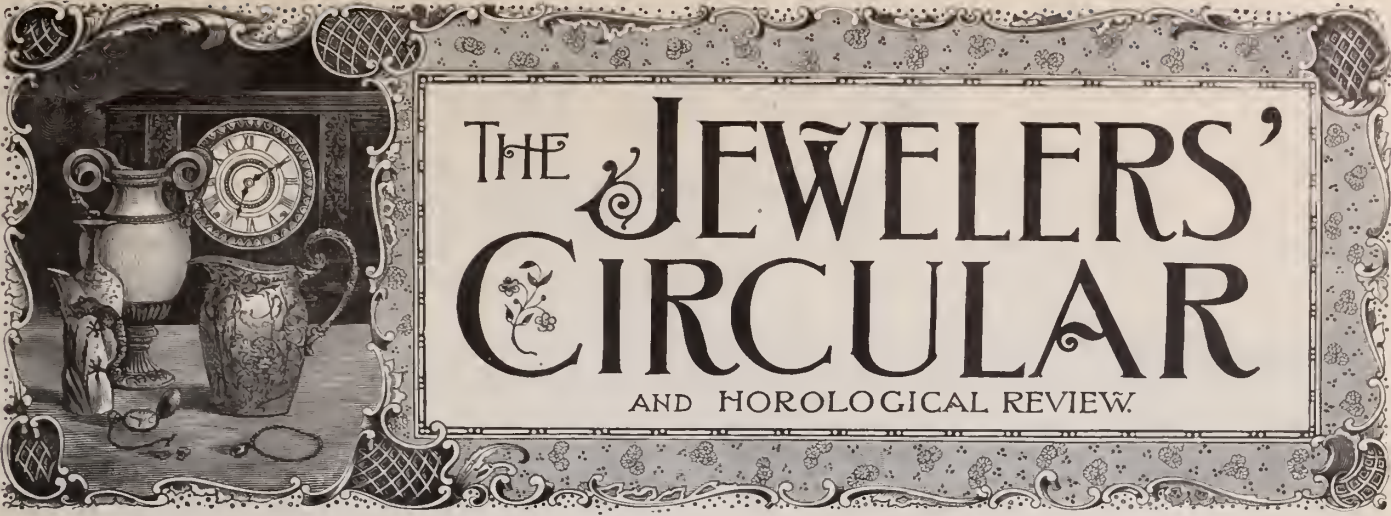

# THE JEWELERS' CIRCULAR

AND HOROLOGICAL REVIEW

Corbin Building, 11 John St., Corner Broadway, New York.

Copyrighted by THE JEWELERS' CIRCULAR PUB. CO.

Entered at the Post Office in N. Y. as second-class matter.

VOL. XXXIX.

NEW YORK, WEDNESDAY, DECEMBER 27, 1899.

No. 22.

## THE ART OF MAKING CASKETS FOR ADDRESSES.

WHILE the making of gold and silver caskets to contain the addresses of cities to important personages is essentially a foreign craft, obtaining mostly in Great Britain and her colonies, yet there

presented by the city of Bristol, England, to Queen Victoria, referred to in the last issue of THE CIRCULAR, is an especially artistic affair. It was given to the Queen on the occasion of her opening the Bristol

The enamel painted views in the oval medallions represent the Home itself, the Cathedral, Cabot Tower and the Suspension Bridge. This casket, as well as the electric button of gold, gems and enamel,

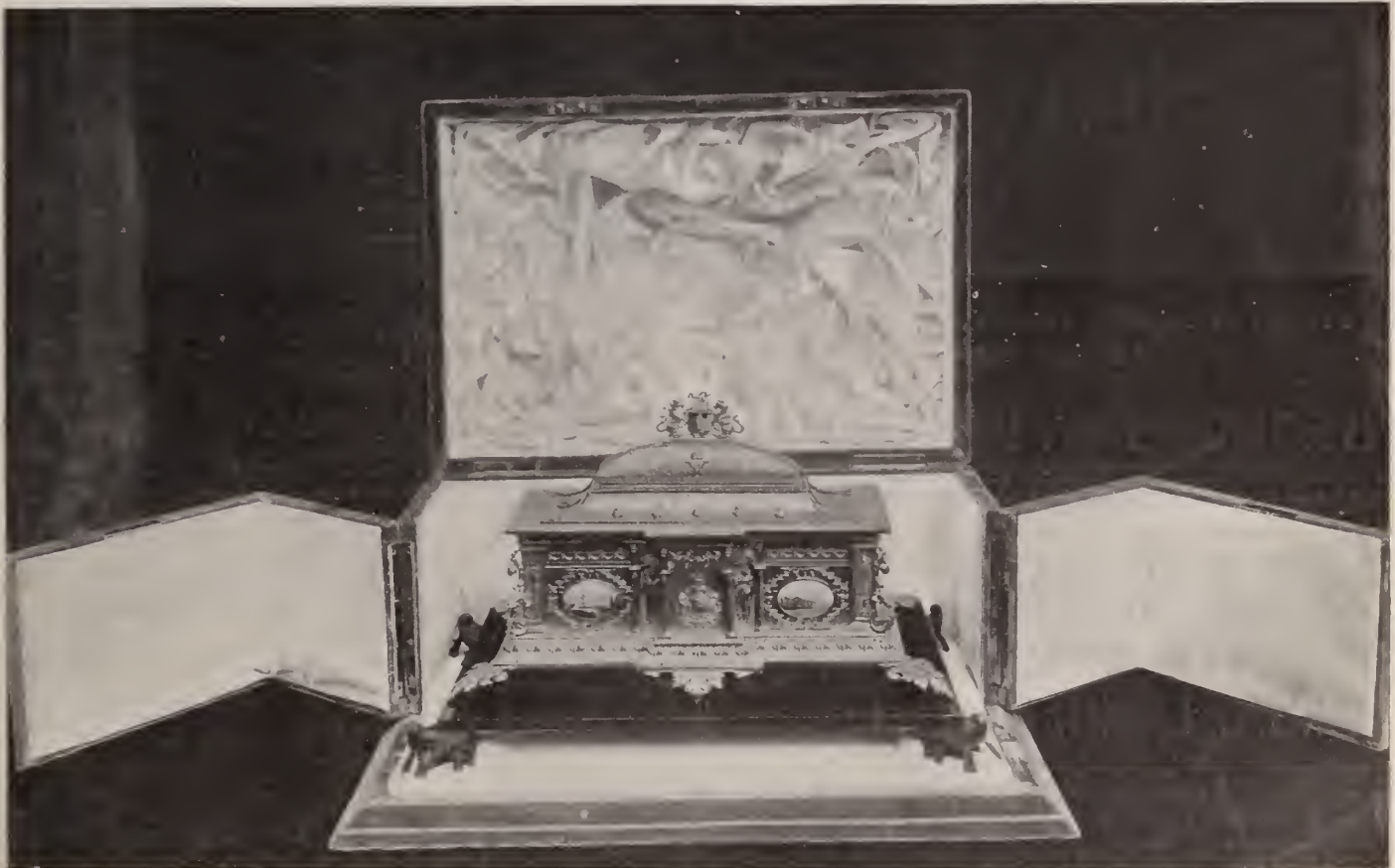

SOLID GOLD CASKET PRESENTED TO QUEEN VICTORIA BY THE CITY OF BRISTOL, ENGLAND.

have been isolated occasions where the craft has been called into requisition in this country. These caskets are fine objects for study in the gold and silversmithing arts, no matter in whatsoever country they are made. The casket pre-

Jubilee Convalescent Home. The casket, of which the front view is given here, contained the address from the Mayor and corporation of Bristol. It is of solid gold in the Renaissance style. The figures represent Europe, America, Asia and Africa.

described and illustrated in the last issue of THE CIRCULAR, was supplied by the Bristol Goldsmiths' Alliance, of College Green, Bristol, an association of several old firms of jewelers. They have received general congratulations upon their work.

# Now Is The Time

to place orders for the Spring season's goods. Our lines are better and larger than ever, and include all that is desirable to complete the stock of a modern, up-to-date jewelry store. The *quality* is the *highest*, the *styles* are the *best*, and the goods are made expressly for the regular, all-the-year jeweler.

**Rolled Gold Plate and Gold-Filled CHAINS, BRACELETS, LOCKETS, CHARMS, PINS, EARRINGS, SILK RIBBON CHAINS, CHAIN MOUNTINGS, DUMBBELL BUTTONS, BROOCHES and BELT BUCKLES.**



Our **STERLING SILVER TOILET and MANICURE ARTICLES** in the Washington, Jefferson, Victoria and American Beauty patterns are always in stock and can be matched or duplicated at any time.

**THEODORE W. FOSTER & BRO. CO.,** 100 RICHMOND ST., PROVIDENCE, R.I.  
Successors to FOSTER & BAILEY.

Established 1879. Manufacturer of

**LOUIS W. HRABA,**  **Fine Leather Goods**

29 East 19th St., New York. Exclusively for the Jewelry Trade.

**THE BASSETT JEWELRY CO.,**

Fine Gold-Filled Chains,  
Lockets and Gold Jewelry,

PROVIDENCE, R. I.

**AIKIN, LAMBERT & CO.,**

MANUFACTURERS OF

**FINE GOLD PENS, HOLDERS, PENCILS,  
TOOTH PICKS and NOVELTIES.**

PAUL E. WIRT FOUNTAIN PENS, at new and lower prices . . .  
MERCANTILE FOUNTAIN PENS, guaranteed to give satisfaction.

Catalogues with terms and discounts furnished to the trade.

**BRANCH, 103 STATE STREET, - - - CHICAGO.**

**AIKIN-LAMBERT JEWELRY CO.,**

IMPORTERS OF

**DIAMONDS.**

JOBBER IN

**WATCHES, JEWELRY, CHAINS,  
NOVELTIES, ETC.**

**LATEST DESIGNS. LOWEST PRICES.**

**19 MAIDEN LANE, NEW YORK.**

# A Prosperous Holiday Trade,

we hope, was your good fortune to experience.

The time consumed in the salesroom during that interval had a natural tendency to cause an accumulation of work, and possibly you ran short of material beforehand, did not have the time to order and do not now have sufficient supplies for your future requirements. If these were the conditions, we should like and hope that you will not overlook the fact that we are able to help you out.

We increased our stock considerably during December, our dull season, believing that there would be more than a normal demand later on, and we are now fully prepared to cope with all emergencies that may arise and to replenish your stock in all departments.

Our equipment is modern and complete, facilities of the highest order, and our promptness all that could be desired. On these good points we base our past success.

We are grateful for your former favors and shall strive to merit a continuance of your appreciated patronage by rendering the best possible service.

In conclusion, we extend to you our best wishes for a Happy and Prosperous New Year.

## L. C. REISNER & CO.

Manufacturing Jobbers, Importers and Exporters,  
Watch Materials, Tools and Supplies,

Jewelry Repairers for the Trade.

LANCASTER, PA.

# "OMEGA" WATCHES.

NONE BETTER MADE. OVER 1,000,000 IN USE.



Pendant Set. 12, 14 and 16 Size.  
Made in Gun Metal, Silver, Gold-Filled  
and Solid Gold Cases.

Send for Price-List.

Our 10 Ligne O. F. "Omegas," full Jeweled Anchor Movements, in 14 K., plain polished or enameled cases, are "just the thing" for the Holiday trade.

Our 12 Size "Omegas," made in 7 and 15 Jewel grades, and Our 16 Size "Omegas," made in 6 different grades—7 Jewels to 21 Jewels—are particularly desirable where fine timepieces are desired.

The "Omegas" are sold only to the regular trade, so no prices will be found in any publication whatever, thereby insuring a good profit.

**Edmond E. Robert, 3 Maiden Lane, N. Y.;**  
**Cross & Beguelin, 17 Maiden Lane, N. Y.,**

SOLE SELLING AGENTS.

## A Happy New Year

and a prosperous New Year awaits the manufacturers who avail themselves of our new lines of

### JEWELERS' FINDINGS FOR 1900.

## Buckles, Galleries, Ornaments, Settings, Pins, Etc.

A NEW AND COMPLETE LINE OF INITIALS IN ALL METALS.

## THOS. W. LIND,

MANUFACTURER OF JEWELERS' FINDINGS,

67 FRIENDSHIP STREET,

PROVIDENCE, R. I.



# The Last Shall be First. 1900

All conditions indicate that the last year of the century will be the best and most prosperous one. The retail jeweler can assure this beyond peradventure if he will carry in stock a complete line of

## The Standard Simmons Chains.

They are the best chains of the century, the acme of the chain-maker's art, and the 1900 line is better than ever. The same can be said of our

**CYRANO CHAINS, LOCKETS, SEALS AND  
MARLOWE BRACELETS.**

...AT JOBBERS...

# R. F. SIMMONS & CO.

Factory and Main Office:

New York Salesroom:

9-13 MAIDEN LANE.

ATTLEBORO, MASS.

SALESMEN FOR 1900.

Western Representative, **LOUIS E. FAY.**

Eastern Representative, **GEORGE L. SWEET.**

New York Representative, **JOHN DRAKE.**

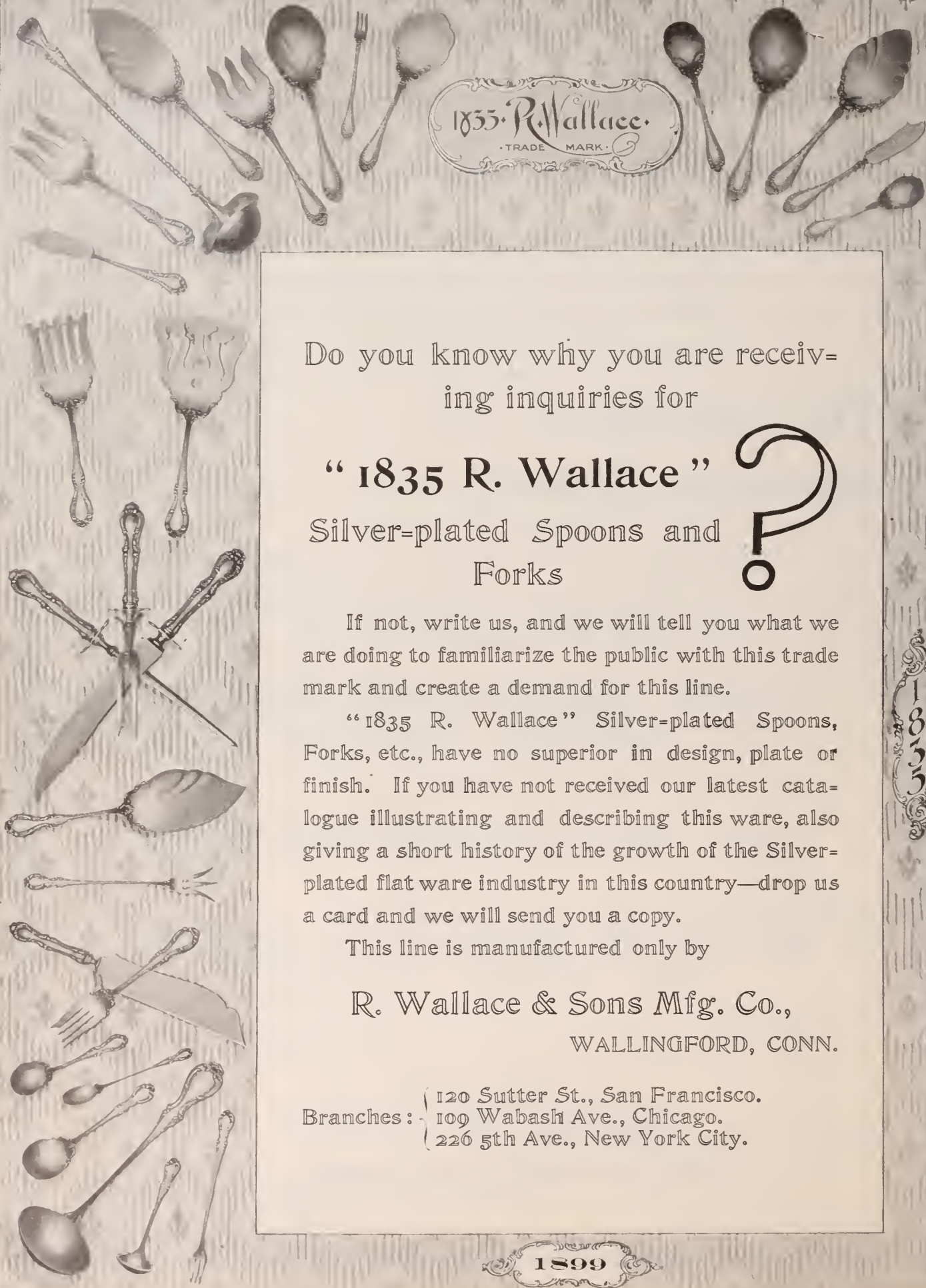

Do you know why you are receiving inquiries for

“ 1835 R. Wallace ”

Silver-plated Spoons and Forks

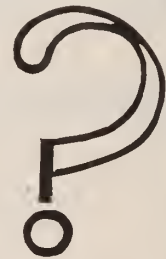

If not, write us, and we will tell you what we are doing to familiarize the public with this trade mark and create a demand for this line.

“1835 R. Wallace” Silver-plated Spoons, Forks, etc., have no superior in design, plate or finish. If you have not received our latest catalogue illustrating and describing this ware, also giving a short history of the growth of the Silver-plated flat ware industry in this country—drop us a card and we will send you a copy.

This line is manufactured only by

R. Wallace & Sons Mfg. Co.,

WALLINGFORD, CONN.

Branches : { 120 Sutter St., San Francisco.  
 { 109 Wabash Ave., Chicago.  
 { 226 5th Ave., New York City.

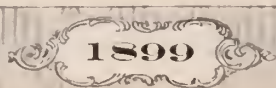
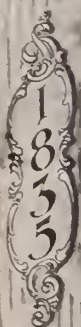

**New Mexico's Precious Stones.**

**Annual Report of the Governor of the Territory Presents Many Interesting Facts.**

WASHINGTON, D. C., Dec. 15.—The annual report of the Governor of New Mexico, which has just been submitted to the Secretary of the Interior, calls attention to the fact that the mountainous part of the Territory, which comprises nearly two-thirds of its entire area and is nearly all mineral bearing, is less known than any part of the United States except Alaska. Already the School of Mines has a collection of more than 200 different specimens of minerals and precious stones that have been found in different parts of the Territory, and it is safe to say that the whole mountain region of New Mexico presents a fair prospecting field, and as yet there is no conception of its many and varied resources.

At the present time development is being carried on more rapidly than ever before in its history. When the prospector and visitor consider that the mineralized regions cover more than 400 miles and strike every county in the Territory, it will be readily seen that the attractions are almost boundless. Among the natural resources of the Territory, already known to investigators are gold, silver, copper, silicified wood, turquoise, garnets and opals, the last being frequently found in the Albemarle group of mines.

The turquoise is the standard gem of all those found in New Mexico up to the present time, the small section of mountainous country in the vicinity of Cerrillos containing to-day the world's best known and most productive turquoise mines. At present there are supposed to be 60 to 70 turquoise claims in the Territory, but only 10 or 12 of these are in active and profitable operation.

According to official statistics the output of turquoise in New Mexico in 1891 was valued at \$150,000; in 1892, \$175,000; in 1893, \$200,000; in 1894, \$250,000; in 1895, \$350,000, and in 1896, \$475,000; how-

ever, there are many people who are in a position in which they ought to know whereof they speak, who do not hesitate to assert that the annual output has not been less than \$1,500,000 any year since 1893. This would appear to be correct when the fact is taken into consideration that one of the mines sold for \$250,000 in 1893. There is a current report to the effect that one stone taken out has been sold in New York for \$6,000.

Traditionally the Territory has been noted as having produced some remarkable gems, and recent developments are proving the older reports to have been correct. It is only recently that scientific research and skilled labor have been directed to this purpose. The result is a steady increase of expert prospecting and labor development.

The estimated value and production of gems up to the year 1890 can be found in the census reports of that year. It is worthy of remark that the amount and the value thereof are understated, the facilities for correct and full information being limited.

Since that time the annual product has more than doubled, and is still increasing. Diligent prospecting has revealed new deposits, and the industry bids fair at present to become a large item in the economic resources of the Territory.

The highest grade of gems found in New Mexico is emeralds, there being one now cut in Santa Fé which weighs 1 karat and is of fine quality. Many smaller ones have been found, although no expert search has been made for them thus far. A very recent find, next in value, is a gem resembling the ruby in respect of color, brilliancy and hardness. Of these, quantities are found frequently associated with peridots and garnets, but differing from the latter in being harder and of a different specific gravity and form of crystallization. The range of color is from light rose or pink to that of a bright red garnet. Though no very large ones have been found, yet

gems cut from those found have sold at \$20 to \$50 each, while their numbers and merits have made them a decided acquisition to the list of precious stones of New Mexico, which must, when more widely known, create for them a large demand.

The turquoise deposits of the Territory are too well known to require an extended description. It is only necessary to state that while some of these gems have been famed in Europe for centuries, yet in the United States they have never met the appreciation their merits and rank as gems deserve until the last few years; now they are in great demand, having been pronounced by experts equal if not superior to the Persian turquoise. There are single gems from Santa Fé county, now in New York, held as high as \$4,000, and some still in the county of nearly equal size and quality. This sudden appreciation has given a stimulus to further research, resulting in finding turquoise deposits of great merit near Silver City, in the Hatchitas and Cow Spring mountains. One of the new discoveries is phenomenally large, considering quantity of production, size and color of stones found in it.

In addition to the above-named are found native euclase, the so-called Montana sapphires, garnets, milk and fire opals, peridots, a great variety of fine agates, besides petrified woods, fit for inlaying, mosaic work or jewelry. Gold and silver quartz, valuable for fine work in jewelry, is produced from various mines.

The Gardiner (Me.) *Independent* says that last week the city had three systems of time in operation. Railroad time was about seven or eight minutes slower than the standard time clock, and that ancient timepiece 33 minutes slower than the local variety. Add to that fact the Universalist Church clock was wheezed up with a sore throat, or something more serious, and unable to strike, and the outside world can have a faint idea of what difficulties Gardiner labored under on the time question.

**THE APOLLO** 

WARRANTS THE EPITHET "POPULAR,"

as shown by sales from Maine to Oregon.

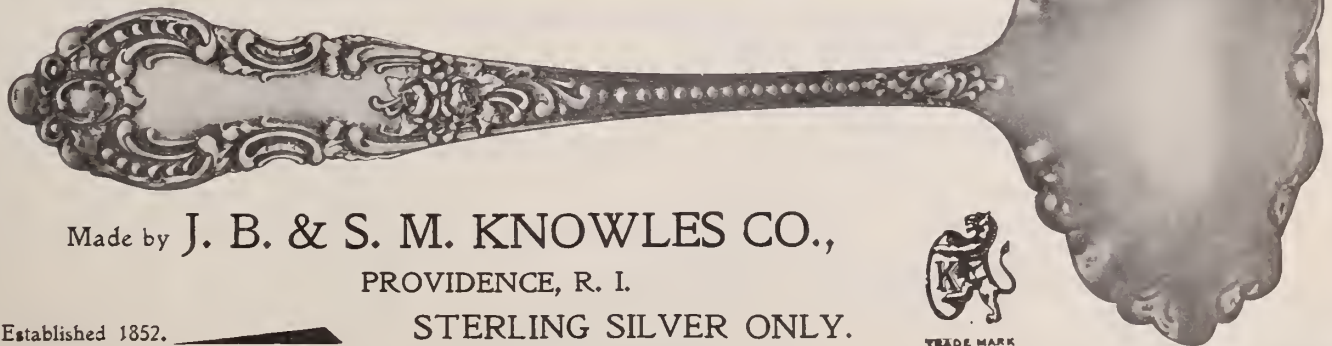

Made by **J. B. & S. M. KNOWLES CO.,**  
PROVIDENCE, R. I.

Established 1852.

**STERLING SILVER ONLY.**



**DIAMONDS.**  
**Wm. S. Hedges & Co.,**  
 IMPORTERS OF  
**Diamonds and Precious Stones.**  
**DIAMOND JEWELRY.**  
**170 Broadway, New York.**  
 26 Holborn Viaduct, London.

## SCHULZ & RUDOLPH,

....Importers and Cutters of....

**..DIAMONDS..** .....AND OTHER.....  
**PRECIOUS STONES.**

SOLE AGENTS FOR THE CELEBRATED

**JULES JÜRGENSEN** **WATCHES AND**  
**COPENHAGEN,** **CHRONOMETERS.**

**28 John and 65 Nassau St., New York.**

**MOUNT & WOODHULL,** FORMERLY WITH LATE FIRM OF  
 RANDEL, BAREMORE & BILLINGS,  
 .... IMPORTERS OF ....

**Diamonds, Other Precious Stones, Pearls, Etc.,**  
**Makers of fine DIAMOND JEWELRY,**

**26 MAIDEN LANE (SOUTHWEST CORNER NASSAU STREET), NEW YORK.**

JOHN C. MOUNT.

ADDISON W. WOODHULL.

**RUBIES.**

**SAPPHIRES.**

**C. G. MALLIET & CO.,**

**EMERALDS.**

**14 MAIDEN LANE, N. Y.**

**DIAMONDS.**

## The Bowden Rings

**ARE COMPLETE IN VARIETY, CORRECT  
 IN QUALITY AND PERFECT IN FINISH.  
 WE MAKE EVERY VARIETY OF FINGER  
 RINGS**

**J. B. BOWDEN & Co.,**

**1 MAIDEN LANE,**

**NEW YORK.**

## U. S. Naval Observatory.

**Report by Board of Visitors Brings Out Several Deficiencies of the Institution.**

WASHINGTON, D. C., Dec. 18.—On June 30, 1899, Secretary Long appointed Hon. Wm. E. Chandler, Hon. Alston G. Dayton, Professor E. C. Pickering, Professor Geo. C. Comstock and Professor Geo. E. Hale to act as a Board of Visitors, for the purpose of visiting and reporting upon the condition of affairs at the United States Naval Observatory, in this city, and the result of their labors is in the nature of a report that is a long way from being satisfactory, so far as existing conditions at the Observatory are concerned. The salaries are thought to be entirely inadequate to secure the class of men best suited for the work, and yet the expense of maintaining this observatory is far in excess of others; for instance, the annual income for the United States Naval Observatory is \$85,000; Paris, \$53,000; Greenwich, \$49,000; Harvard, \$46,000; Pulkowa, \$46,000, and the Cape of Good Hope, \$33,000.

The principal instruments in the Observatory are the 26-inch equatorial telescope, the 12-inch equatorial telescope, the 9-inch transit circle, the 6-inch transit circle, the 5-inch altazimuth and the prime vertical transit instrument. In general the work done with these instruments does not differ from that done elsewhere. The 9-inch transit circle is not now in use, but in the past it has done useful work, including the observation of one of the international zones.

The principal Harvard instruments at Cambridge are the 15-inch equatorial telescope, the 15-inch reflector, the 12-inch meridian photometer, the 11-inch Draper telescope, the 8-inch transit circle, the 8-inch Draper doublet, the 6-inch equatorial telescope and the 4-inch transit photometer. The principal instruments at Arequipa are the 24-inch Bruce doublet, the 13-inch Boyden, visual and photographic, equatorial telescope, the 8-inch Bache doublet, the 4-inch meridian photometer and the 4-inch transit photometer. The 8-inch transit circle is not now in regular use, but with it two of the international zones have been observed. All the other instruments are in regular use every clear night; nearly all of them until dawn, and the work done with them is not duplicated elsewhere.

The principal hindrances to a favorable comparison of the Naval Observatory with other places are briefly summed up as follows: First, the relation of the Observatory to the Government, which makes its management complex; second, the frequent changes in its executive officer, which render a policy of long continuance difficult; third, the salaries which ought to be much higher than in private institutions to secure equally good men; fourth, promotions in cases of special skill and removal in cases of inefficiency are difficult; fifth, specific expenditures which ought to be provided for in advance and not changed if conditions alter. Many of these difficulties would be diminished with an efficient and active executive, thoroughly familiar with the scientific work of the

institution and having power to enforce needed reforms. A board of visitors, independent of Government control, but having power to make the necessary changes, would greatly aid such an executive. Another item of which special mention was made was the almost absolute dearth of reliable printed information as to the work of the Observatory.

The new Observatory buildings on Georgetown Heights were first occupied in 1893. The instrumental equipment is for the most part new, few of the instruments of the old Observatory having been retained in their original form. An entirely new mounting was provided for the 26-inch equatorial telescope, and the 9.6-inch telescope was replaced by a new refractor of 12 inches aperture. A large spectrograph, of modern design, was furnished for the 26-inch telescope. The new instruments, constructed entirely of steel, were added to the equipment. One of these is a meridian circle of 6 inches aperture, and the other is a 5-inch altazimuth. The 8.5-inch Pistor & Martens meridian circle was furnished with a new objective of 9.1 inches aperture, and the mounting was reconstructed. All the new instruments are of American make.

**Timely Information Regarding Brazilian Diamonds.**

BOSTON, Mass., Dec. 22.—John B. Humphrey has just received from Nelson F. Humphrey, who went to Brazil several months ago in quest of rare gems, a lot of Brazilian diamonds in the rough, which are as promising for cutting as the finest Kimberley diamonds. Nelson F. Humphrey had been prior to his trip to Brazil foreman of the John B. Humphrey cutting factory in Boston, and his judgment is that of an expert on rough stones. These were secured far in the interior, and are river deposit stones principally. A number of blues are in the package forwarded.

Mr. Humphrey will remain in Brazil for some time to come. This venture was decided upon by John B. Humphrey while the Transvaal outbreak was impending, and may be cited as a conspicuous example of Yankee enterprise in a time of business emergency.

The present deep interest in Kimberley and the diamond mines of that city has caused a great demand from jewelers all over the country for photographs and pictures of these mines, for exhibition in their stores and show windows. The article in THE CIRCULAR of Nov. 15, on the Kimberley mines, giving illustrations of the various processes of mining, has been followed by requests from jewelers all over the country for copies of the photographs from which these illustrations were taken. To satisfy the demand Ludwig Nissen & Co., diamond dealers, 18 John St., New York, are about to issue a handsome card hanger that will contain 10 fine half-tone illustrations of the Kimberley mines. These hangers will be presented to all legitimate retail jewelers who shall send in an application to this firm. The hanger will be about 10x16½ inches. An idea of it may be obtained from the advertisement published in this issue on pages 24 and 25.

ESTABLISHED 1840.

**Chester Billings & Son,**

Successors to **RANDEL, BAREMORE & BILLINGS,**

IMPORTERS OF

1840 RANDEL & BAREMORE.  
1866 RANDEL, BAREMORE & CO.  
1880 RANDEL, BAREMORE & BILLINGS.

**DIAMONDS**

OTHER PRECIOUS STONES AND PEARLS.

58 Nassau Street,  
29 Maiden Lane, 22 Holborn Viaduct,  
NEW YORK. LONDON, E. C.

✻ DIAMOND JEWELRY. ✻

*Oppenheimer Bros. & Veith,*

*Importers and Cutters of*

*Dealers in*

**Diamonds**



**Watches,**

*Cor. Nassau and John Streets,*

*(PRESCOTT BUILDING.)*

*...New York...*

*Amsterdam,  
? Tulp Street.*

*London,  
45 Holborn Viaduct.*

**Pearls**

**Opals**

Importers and Cutters

**GOODFRIEND BROS.,**

Precious and Imitation Stones

9-13 Maiden Lane, N. Y.

174 Weybosset St., Providence, R. I.

10 Rue Cadet, Paris.

TELEPHONE, 662 CORTLANDT.

**John F. Saunders,** Cutter and Importer of

**DIAMONDS**

AND OTHER PRECIOUS STONES.

FINE PEARLS A SPECIALTY.

68 Nassau St., cor. John St., Sheldon Building, Room 16, NEW YORK.

**WM. H. BALL & Co.,**

Our Specialty:

MANUFACTURING JEWELERS,

Anderson Building, 12-14-16 John St., N. Y.



Everything in

**Gold Bracelets.**

Curb Bracelets, Bangle Bracelets, Fancy Stone Bracelets, Baby Esther Bracelets, Bracelet Mountings.

## PEARLS.

**Business Reasoning.**

In doing business with "specialists" devoting all their time and attention to but one line of goods, the dealer reaps all the benefit of the specialists' expert knowledge.

We are specialists, with years of experience, a requisite to expert knowledge in our line.

**Alfred H. Smith & Co.,**

182 Broadway, N. Y.

CHICAGO.

LONDON.

## DIAMONDS

And Other Precious Stones.



"The Pearl House."

We have no salesmen; call or write.

**EISENMANN BROS.,**

PARIS, 3 Rue St. Georges.

21 &amp; 23 MAIDEN LANE, NEW YORK.

**MATHEWS & PRIOR,**

DESIGNERS AND MAKERS OF

**Sterling Silverware**

TO THE LEGITIMATE

**JEWELRY TRADE ONLY,**245-247 West 28th Street,  
New York City.**The Name "Lemaire" on Optical Goods Protected by the Courts.**

The action recently mentioned in THE CIRCULAR that was brought by Jean Baptiste Baille, of Paris, against Mrs. T. Lynch, of New York, to restrain the latter from using the word "Lemaire" in connection with opera glasses not made by him, has resulted in a decree for the complainant. As already told in THE CIRCULAR, Mr. Baille, who is the successor to the house of A. Lemaire, sought to restrain the defendant from infringing the name, on the ground that he had a trade-mark right in it.

By the decree, which was entered last week by consent of counsel, Judge Lacombe, of the United States Circuit Court, orders and adjudges first, that Mr. Baille is entitled to the exclusive use of the name "Lemaire" as a trade-mark and a trade name for opera glasses, field glasses, marine glasses and optical goods of every description; second, that an injunction issue against Mrs. Lynch, her agents and employes, restraining them from selling opera or field glasses or optical goods of any nature to which is applied the word "Lemaire," or any name which is to the eye or ear substantially like it, except as to glasses made by the complainant; also, that they be restrained from using any such word in printed or written matter in connection with any glasses not the complainant's, and, in addition, be enjoined against advertising any article which would cause the goods not made by Baille to be offered or sold under the name "Lemaire." The damages which the complainant claimed having been settled out of court, the decree provides for no recovery or accounting. The injunction, which is made perpetual, was issued Thursday.

**Walter R. Bristol Awarded a Verdict in His Suit for Salary.**

MERIDEN, Conn., Dec. 22.—Decision in the case of Walter R. Bristol vs. C. Rogers & Bros. was handed down to-day by Judge Platt, of the Meriden City Court. The case was tried Dec. 7 and 8. The decision was for plaintiff to recover \$175 with interest from Feb. 1, 1899, and costs.

The plaintiff brought suit to recover one month's salary from Jan. 1 to Feb. 1, 1899, amounting to \$271.77. This is the suit during the trial of which Judge Platt threatened to send John Harmon and George Rockwell, of the International Silver Co., to jail for contempt of court for refusing to answer questions put to them by Judge W. F. Davis, counsel for C. Rogers & Bros. A lengthy account of the trial was published in THE CIRCULAR of Dec. 13.

**Trans-Atlantic Voyagers.**

FROM EUROPE.

Sol Fox, of Fox Bros. & Co., Cincinnati, O.; Carl Bawo, of Bawo & Dotter, New York; and S. M. Schiele, of Wallach & Schiele, New York, accompanied by his wife, returned from Europe last week on the *Kaiser Wilhelm der Grosse*.

A. A. Preston, formerly of Tioga, Ia., has opened a repair shop in Rose Hill, Ia.

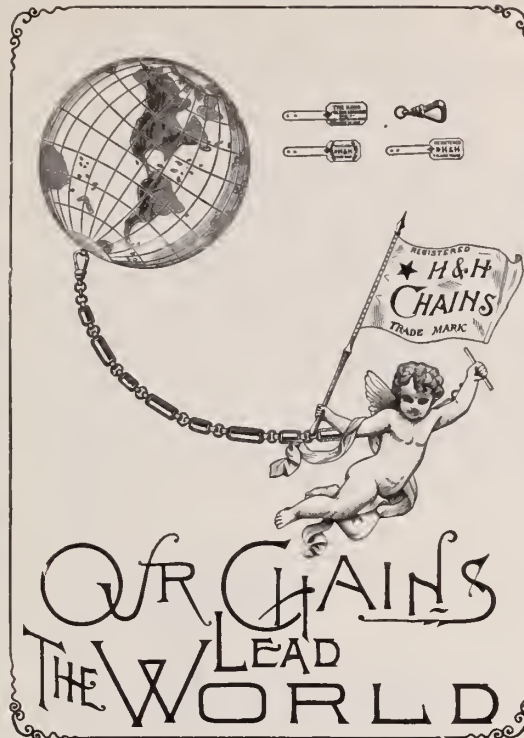

## To the Trade:

*Accept our thanks for all favors and patronage bestowed on the*

# ★ *H. & H. Chains and... Silver Novelties.*

*To all our friends, old and new, we wish good health and a very happy and prosperous year, and trust that your highest anticipation for the year 1900 may be realized.*

## *Hamilton & Hamilton, Jr.,*

*Providence, R. I.*

*New York, 11 John Street.  
Chicago, Stewart Building.*

*San Francisco, Claus Spreckles Bldg.  
London, 94 Hatton Garden.*



**A. & B.**

**HEADQUARTERS**

FOR

**Waltham Watches**

EVERY GRADE.

**AVERY & BROWN,**

68 Nassau St., New York.

OTTO K. TREIBS.

PAUL E. TREIBS.

**TREIBS BROS.,**

68 Nassau St.,

New York.

139 Mathewson St.,  
Providence, R. I.

CUTTERS AND IMPORTERS OF

**Opals.**

**F. E. TREIBS,**

Oberstein,

Germany.

ESTABLISHED 1842.

HERMANN TREIBS.

ALBERT TREIBS.

EMIL TREIBS.

**CASH OFFERS.**

If at any time you have offered to you by your customers any Jewelry containing diamonds, pearls or other precious stones, and you do not care to buy them yourself, send them to us and we will submit an IMMEDIATE CASH OFFER. Trade and Bank References if desired. Established 1880. Correspondence solicited.

CHARLES S. CROSSMAN & CO.,  
3 Maiden Lane, New York.

**Oskamp, Nolting & Co. Win Their Case Against the Southern Express Co.**

COLUMBUS, O., Dec. 19.—Oskamp, Nolting & Co., Cincinnati, to-day won their case against the Southern Express Co., and recover \$562 damages from that corporation.

The express company delivered to a swindler a package of jewelry shipped by Oskamp, Nolting & Co. to T. M. Jones, a reputable merchant, of Hopkinsville, Ky. They sued to recover the value of the package, and the express company resisted on the ground that the jewelers had not attached the value of the package to it when shipped. The jewelers got a verdict in the Common Pleas Court, the Circuit Court reversed, and now the Supreme Court reverses the Circuit Court, and the judgment as given in the Common Pleas Court stands.

It will be remembered that a swindler named Abe Rothchild ordered expensive jewelry from many jewelers throughout the country from various cities, under the name of some rich and prominent citizen of those places respectively. From Hopkinsville, Ky., he ordered under the name of T. M. Jones, a prominent and wealthy citizen of that place, some diamonds from Oskamp, Nolting & Co., and the order was filled by the firm. It developed later, of course, that the real Jones had had no connection with the transaction, and the jewelry firm sued the express company for delivering the diamonds to Rothchild instead of to the real Jones, to whom they were directed. It will also be remembered that Rothchild was arrested promptly through the publication in THE JEWELERS' CIRCULAR of his methods and the general form of the letter which he sent to the various jewelers. Thos. Lees, Hamilton, Ont., who had read the matter in THE CIRCULAR, caused his arrest.

**Green Bros. Get a Verdict Against M. J. Garfinkel.**

HARTFORD, Conn., Dec. 22.—The suit of Green Brothers, New York, against M. J. Garfinkel, this city, was tried before Judge Case and a jury in the Court of Common Pleas yesterday. The plaintiffs sought to recover \$76.10, with interest, balance alleged to be due for goods. The defendant claimed that he had paid for several articles charged to him in the bill of

particulars, that other goods were not as represented and that some of the goods were sold on 90 days' credit and that the 90 days were not up at the time of bringing of the action. The jury went out about 4 o'clock and returned to the court room with a verdict shortly before 6 o'clock. The verdict was that the plaintiffs recover \$41.85.

**Hezekiah Myers, Once a Jeweler of Atlanta, Reported Murdered.**

ATLANTA, Ga., Dec. 22.—The decomposed body found in the swamps near Yellow Water creek is believed to be the body of Hezekiah Myers, a jeweler, who for a number of years was a citizen of Atlanta, but for several months has been living in Butts county at the home of a farmer named Lewis. The remains have been identified by members of the Lewis family who knew Mr. Myers well, and there is little doubt now but that Mr. Myers was brutally murdered for the money he had on his person and that the body was dragged into the swamp, where it was placed for safe keeping.

**Alleged Jewelry Robber Hery Trying to Get Counsel to Defend Him.**

WILLIAMSPORT, Pa., Dec. 20.—M. Hery, the alleged diamond thief, now confined in the county jail awaiting trial for the theft of a diamond ring from H. Jackson's jewelry store, has made an effort to secure the services of N. M. Edwards to appear as his counsel. Mr. Edwards has decided that he will not consent to be retained in the case until after he has had an interview with one of the Chicago firm by whom Hery was employed.

A pile of rubbish caught fire a few days ago from the furnace in the basement of the building occupied by W. F. Kirkpatrick & Co., St. Joseph, Mo. The building was thought to be on fire and an alarm was turned in. The blaze was extinguished without damage.

E. D. Cole, of Berlin, N. H., who was in the employ of the late George L. Prescott, of that place, at the time of the latter's fatal trip on the steamer *Portland* a year ago, has started in business in Berlin on his own account, carrying a line of jewelry and optical goods.

OLIVINES OPALS SCIENTIFIC RUBIES	CATSEYES   SAPPHIRES   DIAMONDS   RUBIES   EMERALDS   PEARLS   PEARL NECKS   PEARL ROPES	Pearl Collarettes, mounted with Diamond Bars.
	<h2>PEARLS, DRILLED AND UNDRILLED.</h2> <h3>PEARL ROPES, NECKS and COLLARETTES.</h3> <p>We are buyers of American Pearls.</p>	
	LONDON: 19-20 Holborn Viaduct. <b>JOSEPH FRANKEL'S SONS,</b> 68 Nassau Street, NEW YORK. TELEPHONE, 3899 CORTLANDT.	
	FANCY COLORED DIAMONDS and GEMS in PEARLS and PRECIOUS STONES.	



## The Duty on Watches.

### Contentions as to the Interpretation of the Tariff Paragraph Before the Courts.

A customs suit involving points of considerable interest to the watch trade of this country was argued Thursday before Judge Townsend, of the United States Circuit Court, New York. The action is on an appeal from a decision, rendered last September by the Board of General Appraisers, on the protest of Jules Racine & Co., watch importers, 37 Maiden Lane. The point involved in the protest and in the appeal now before the Court, is the construction of paragraph 191 of the present Tariff law, providing for the duty on watch cases and watches. Paragraph 191 reads as follows:

191. Watch movements, whether imported in cases or not, if having not more than seven jewels, 35 cents each; if having more than seven jewels and not more than 11 jewels, 50 cents each; if having more than 11 jewels and not more than 15 jewels, 75 cents each; if having more than 15 jewels and not more than 17 jewels, \$1.25 each; if having more than 17 jewels, \$3 each, and in addition thereto, on all the foregoing, 25 per centum ad valorem; watch cases and parts of watches, including watch dials, chronometers, box or ship, and parts thereof, clocks and parts thereof, not otherwise provided for in this Act, whether separately packed or otherwise, not composed wholly or in part of china, porcelain, parian, bisque or earthen ware, 40 per centum ad valorem; all jewels for use in the manufacture of watches or clocks, 10 per centum ad valorem.

It will be noticed that this paragraph provides for a specific and an ad valorem duty on watch movements, whether imported in cases or not, and then goes on to provide a duty of 40 per cent ad valorem on watch cases and parts of watches. Jules Racine & Co. imported a number of complete watches which were segregated by the Collector and assessed under this paragraph so as to make the cases and movements or works dutiable separately. The movements were assessed first according to the number of jewels, and in addition 25 per cent, while the cases were assessed at 40 per cent. It was urged by the importers, both in the argument before the Board of General Appraisers and before the United States Court last week, that according to the simple construction of the tariff clause complete watches are provided for in the first section, which includes movements whether imported in cases or not, and are not subject to any other or higher rate of duty than is provided for in the first part of the paragraph, or in other words no separate duty was to be paid on the cases. If this be not so the importers contended that the whole watch would then be dutiable at 20 per cent under Section 6 as a non-enumerated manufactured article. The Board of Appraisers' decision, from which the appeal was taken, was an elaborate one. It covered this and other protests and was published in full in THE CIRCULAR of Oct. 5, 1898.

At the argument of the appeal from this decision, which occupied a good part of Thursday morning's session of the United States Circuit Court, there was no question of fact raised, the whole contention being on the interpretation of the law. The Government was represented at this argument by Assistant District Attorney Platt and also by Mr. Huntington, of New York, and Mr. Thompson, of Boston,

special counsel retained by certain American watch companies to aid the Government in fighting these protests. The importers were represented by Wm. B. Coughtry, who also has the Tiffany protests on drilled pearls, recently spoken of in these columns. Judge Townsend reserved decision.

### To Fight for \$20,000 Worth of So Claimed Smuggled Diamonds.

DETROIT, Mich., Dec. 22.—Louis Bush, who was charged with smuggling \$20,000 worth of diamonds at Detroit, is going to fight the Government for the possession of the gems. The order of Judge Swan, of the United States Court, to sell the diamonds at public auction because they

were unclaimed, was revoked this week upon application of George F. and Jas. A. Robinson, and ex-Postmaster-General Don M. Dickinson. With Mr. Dickinson and the Robinsons will be associated Isaac Fromme, of New York. The formal legal answer to the Court in the preliminary fight sets forth that while it is true the diamonds were seized, this was unrightfully done; that they were not fraudulently imported into this country and were not subject in law to the payment of customs duties. Louis Rosenberg, of New York, was their owner and Louis Bush was acting as his agent. The attorneys will have hard work to explain why Bush dodged about all over Canada and then hid the gems in his stockings, if his business was legitimate.

## Calm Thought,

following the rush of Christmas business, suggests that you fill up your depleted stock of Diamonds and Diamond Jewelry. In doing this we can render you valuable assistance, for our stock is very large and combines effect, quality and price in most satisfactory proportions.

BROOCHES, CORSAGE ORNAMENTS,  
RINGS, STUDS, SCARF PINS,  
PEARL NECKLACES.

## HAYDEN W. WHEELER & Co.,

TWO MAIDEN LANE, N. Y.

50 HOLBORN VIADUCT, LONDON.

**Death of Elton I. Franklin.**

NORTH ATTLEBORO, Mass., Dec. 22.—Elton I. Franklin, one of the most conspicuous figures in North Attleboro for a generation, passed from the theater of events Wednesday night, after a lingering illness. In his death the town loses one of the class of men who are but too seldom found in any community, and who can ill be spared.

Mr. Franklin was the son of W. B. Franklin, who married a daughter of Harvey M. Richards. Thus he came of jewelers' blood on both sides. His father was one of the earliest owners of jewelry factories in the town, and Harvey M. Richards is a name known the country over as, at one time, a leader in the trade. At the age of 17 years, Elton Franklin went to New York and served his novitiate in the jewelry business by hard work in the H. M. Richards shop. Returning to North Attleboro he was associated with the business there, and in 1874 he organized the firm of which he was senior partner at the time of his death. Three years previous he had married the daughter of Wallace Goodwin, known in horological circles of a generation ago, and a son, Wallace, and a daughter, Gertrude, joined the family circle. His business affairs have steadily prospered for, as a business man, he was highly talented. His associates in lodge, town and trade affairs recognized in him a born leader and to him entrusted the direction of all affairs involving business transactions. Thus he was for years prominent in the administra-

tion of the affairs of North Attleboro, and his abilities would have carried him into wider political fields had he been willing. As an assessor he is given a large share of the credit for the rescue of his town from embarrassing straits several years ago. As a member of the commission appointed for that purpose he secured the town an electric light plant, and his name is a passport for the most energetic days of the administration. In the water department he gave the town its present pumping station and system, and to him was entrusted the erection of the memorial library with the fund given by the late Ira Richards. He was head of the town's Republican interests for years, and was president of the Mount Hope Cemetery Association, being a leader in the movement which has made it one of the most beautiful of its kind in this part of the State. In Bristol lodge of Masons, the chapter and council, and Bristol Commandery of Knights Templar as well as Aurora Lodge of Odd Fellows he was a leading spirit and for years an officer.

His funeral will occur on Sunday from his beautiful home on Church St., North Attleboro.

**Death of John P. Noble.**

WALTHAM, Mass., Dec. 23.—John P. Noble, a well known optician of this city, died on Wednesday last after a brief illness from typhoid pneumonia. He had been identified for many years with the

jewelry and optical trade, but of late had given his attention more particularly to the latter. He had many friends in this city and in Boston among the members of the trade, and was prominent socially, being a Past Master of the Masonic lodge in Waltham. He was 52 years of age and left a wife. His funeral took place to-day with Masonic rites.

**Another of the Pittsburgh Diamond Thieves Reported Captured.**

BOSTON, Mass., Dec. 22.—Charles Harris, better known as "Doc" Harris and with a string of aliases, is in custody in Boston, where he is to be held while the Pittsburgh authorities are communicated with in regard to his alleged connection with the attempted robbery at the store of A. E. Siedle. It remains now to get William Devlin, the third partner in the exploit.

Harris, who was captured Wednesday, is about 45 years old. He has spent much of his time in recent years in prison, and had been out of the Eastern Penitentiary but a very short time when the Siedle diamond job was arranged. While he has been known as a shoplifter and general thief, he has a liking for the diamond line. As far back as November, 1894, information was received by the police that he and two others, one of whom was named Gordon, had arranged to rob the Knowlton jewelry store at 174 Tremont St. A close watch was kept, which resulted in the arrest of Gordon in the store with a blackjack concealed about his person.

During the busy hours of a recent afternoon some miscreants broke two holes in the large plate glass show window of the store of Nicholas Kos, 137 Genesee St., Buffalo, N. Y., evidently with the intention of securing some of the valuables displayed therein. Luckily the thieves were frightened off without securing any booty.

**Florentine Bronzes.**—Following are two processes for Florentine bronzing: Take sanguine (blood-stone), 4 parts, and graphite, 1 part. Mix the whole with either essence or spirit of wood, and cover the object to be bronzed with this composition by means of a brush. Let dry and rub with a dry brush to remove the excess. Next pass a dry brush over a piece of wax and rub the bronzed piece with it. Or else take sanguine, 3 parts, ferric carbide, 1 part, and graphite, 1 part. Bray it all well, mix with wood-spirit and otherwise proceed as pointed out above. To bronze copper articles, it is necessary to first pickle them, *i. e.*, to pass them through aqua-fortis, then to rinse them several times and to dry in sawdust. Objects of iron, zinc, &c., have to be coppered before applying the bronze. The coppering is done either by the electric battery or merely by wetting, in placing the article in a bath of copper sulphate. For Florentine bronzes the coppering must be red. The bronzing may be rendered lighter or darker by adding more sanguine or graphite. Several coats may be given if desired, but in that case the wax must not be applied till after the last coating.

WATCHES

WATCHES

WHO SAID WATCHES?

Ladies' Watches,  
Gentlemen's Watches,

Railroad Watches.

We Are the Largest Distributors of

Dueber-Hampden Watches

IN NEW YORK.



John N. Pierwood & Co.

Watches. Chains. Diamonds. Jewelry.

No. 3 MAIDEN LANE, NEW YORK.

# THE DUEBER HERALD

THE ADVOCATE OF HONEST BUSINESS METHODS.  
\* DEVOTED TO THE RETAIL JEWELRY TRADE.\*

Vol. I.

CANTON, OHIO, DECEMBER, 1899.

No. 11.

## 1900.

1900.

\* \* \*

A new year!

\* \* \*

What changes will it bring? What new fields will it open? What fallacies will it explode? And what new lessons will it teach?

\* \* \*

Let us hope that it will explode one fallacy, at least. The fallacy of putting faith in the "explained," machine-made, ever-"improved" watch.

\* \* \*

Let us hope, further, that it will teach one lesson, at least. The lesson that the honest dealer must stand by the banner of the honest manufacturer for the sake of Honest Business.

\* \* \*

A Happy New Year.

## A PROMISE KEPT AND A PROMISE MADE.

A fitting fin-de-siecle climax to the many incomparable achievements of the Dueber-Hampden Works is the production of their new 12-size watches, illustrated in the last issue of **The Dueber Herald**.

In speaking of these watches it is difficult to refrain from eulogiums; difficult to refrain from praise that comes dangerously near the "sloping-over" point.

They are perfect time-keepers; perfect in every component part, perfectly put together, perfect in finish. They embody the most advanced ideas in watch-making, yet are wholly devoid of a single device that is experimental or of questionable merit. They are the closest-running, handsomest, most trustworthy time recorders ever produced.

In presenting this, their last contribution to the achievements of the century beginning with the figures 18, the Dueber-Hampden Works feel that a generous reward has come to them for their years of ceaseless labor, and they enter upon the new era with the promise that the success behind them will but serve as a spur for still greater enterprise and energy.

## YOURS TRULY, THE EDITOR.

The Dueber Herald trusts your Christmas trade has been satisfactory.

\* \* \*

Twenty-two weeks have passed since **The Dueber Herald** made its first bow to you, to tell you some of the things it knew about watches, movements and cases; to help you to larger watch sales.

\* \* \*

Naturally **The Herald** takes a deep interest in your affairs—your "watch affairs." Has it been of help to you?

\* \* \*

If it has, it will be of still greater help in 1900. If it hasn't, it'll begin to be.

\* \* \*

For such generous appreciation as it has received—and that has not been inconsiderable—**The Herald** extends its warmest thanks.

Bluefield, West Va.  
I am conductor on the N. & W. R. R. I have had a Hampden watch for three years. I would have no other watch while I can get the Hampden.  
GEO. S. LEWIS.

Let Columbia time  
Her Progress by the  
Dueber-Hampden Watch.

Slater, Mo.  
Have carried your 17-jewel watch since last July. It has given the best of satisfaction. I could not ask for anything better for railroad work.  
JOHN G. YOUNG, Conductor,  
C. & A. R. R.

# Gifts for Men



TRADE-MARK.

In 14-Karat Gold—ORNAMENTED WITH PRECIOUS STONES—and in Sterling Silver. Goods that appeal to refined people at all times. Made handsomely, heavy and exclusively for the Jewelry trade.

**Woods & Chatellier,**  
Gold and Silversmiths.

860 Broadway, N. Y.  
42-46 Hill St., Newark, N. J.

## Importations at the Port of New York.

Weeks Ended Dec. 23, 1898, and Dec. 22, 1899.

China, Glass and Earthen Ware:	1898.	1899.
China .....	\$57,271	\$65,896
Earthen ware .....	14,438	8,882
Glass ware .....	18,391	25,203
Instruments:		
Musical .....	15,546	10,716
Optical .....	5,869	4,850
Philosophical .....	371	632
Jewelry, etc.:		
Jewelry .....	5,912	3,373
Precious stones .....	213,551	114,604
Watches .....	23,974	23,574
Metals, etc.:		
Bronzes .....	5,529	4,045
Cutlery .....	15,703	13,190
Dutch metal .....	57	1,208
Plated ware .....	25	7
Platina .....	28,405	33,299
Silver ware .....	1,564	1,518
Miscellaneous:		
Alabaster ornaments .....	188	87
Amber .....	.....	.....
Beads .....	312	1,998
Clocks .....	3,532	4,342
Fans .....	3,101	7,184
Fancy goods .....	7,998	9,696
Ivory .....	1,577	20,936
Ivory, manufactures of.....	300	394
Marble, manufactures of.....	4,169	2,408
Statuary .....	4,852	2,876

# The Leader

...IN...  
HIGH GRADE  
WATCHES

—IS THE—

## VACHERON & CONSTANTIN,

GENEVA, SWITZERLAND.

FIRST in { Quality,  
Adjustment,  
Durability,  
Style.



TRADE-MARK.

FITS ALL SIZES  
OF AMERICAN  
CASES.

{ NEW GRADES  
SIZES  
IMPROVEMENTS.

{ SPECIAL GRADES  
FOR RAILROAD  
MEN.

**EDMOND E. ROBERT,** 3 Maiden Lane,  
SOLE AGENT, New York.

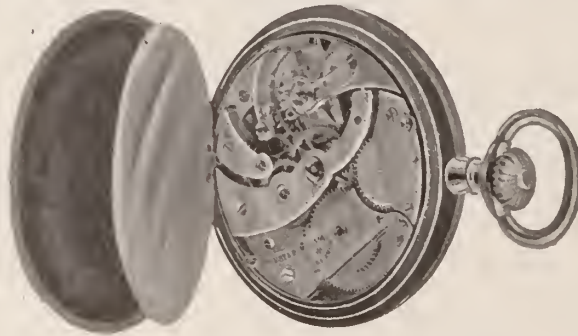

## Jewelry Store Thieves Active in the City of Brotherly Love.

PHILADELPHIA, Pa., Dec. 22.—The big jewelry store of Bailey, Banks & Biddle Co., as well as a number of other stores throughout the city, was robbed during this week of diamonds and jewelry aggregating altogether several hundred dollars in value by expert thieves who worked successfully in the holiday crowds.

Two of the most daring robbers, Frank Hall and Charles Wilson, of New York, were "shadowed" by Detective Tate in Snellenburg's store. They were followed to Wanamaker's and thence to Bailey, Banks & Biddle Co.'s. Upon leaving the last establishment the suspects went to a pawnshop where they were arrested while disposing of four diamond cuff buttons and several diamond stick pins. They were held in \$1,000 bail each for further examination.

Two gold watches were stolen from the jewelry store of George Brummers, 1125 Columbia Ave., by a negro sneak thief, who grabbed the watches while the proprietor's attention was attracted elsewhere and made his escape.

# Mossberg & Granville Mfg. Co.,

PROVIDENCE, R. I.

MANUFACTURERS OF

## JEWELERS' AND SILVERSMITHS' MACHINERY.

Power Presses, Wire Drawing Machinery,  
Rolling Mills, fitted with Roller Bearings.

If in the market for the above machinery, write us, sending samples with output required and let us send you photographs of our latest productions.

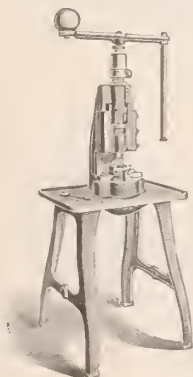

No. 1A, Screw Press.

N. Y. Office, 26 LIBERTY STREET.

Exhibition at the Philadelphia Bourse.

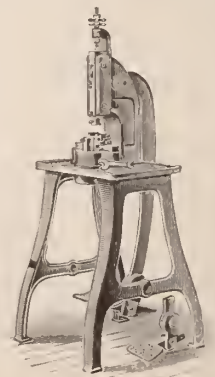

No. 1A, Foot Press.

**Last Move in the Suit of Frank W. Smith vs. Meriden Britannia Co.**

HARTFORD, Conn., Dec. 16.—Judge Shipman held a hearing in the United States Circuit Court, this morning, in the case of Frank W. Smith against the Meriden Britannia Co. March 27, an order of Court was entered denying an application for an injunction. Mr. Smith appealed to the Circuit Court of Appeals, which affirmed the order Nov. 18. This morning Judge Shipman passed an order making the order of the Appellate Court stand and that in addition the defendants recover the costs in the Circuit Court.

**Party with a Quantity of Watches Arrested on Suspicion.**

ROME, N. Y., Dec. 20.—Officers have arrested a man here who may prove to be a prize. When searched he had four new solid gold hunting case watches, with Rockford works. He claims he is an agent, but refused to give the name of the firm employing him. While on the way to the station he threw away the check for his satchel. The satchel subsequently was learned to contain four more watches, clothing marked G. W. Kennedy, although he gave his name as George Wilson, of New York. Clayton Midlam, jeweler, first put the police onto the stranger, who was in his store trying to dispose of the watches. He gives his age as 35, and is about five feet six inches tall, weighs about 175 pounds; large, smooth face, rather light clothes, black overcoat and black derby hat.

In the grip were two sample books, such as agents carry, and a card containing samples of book binding. The watches are all of one pattern and are 14 karat gold cases, with Rockford movements. They would retail at \$40 to \$50 each. The watch cases are marked "B. W. C. Co." and are numbered as follows: 75741, 75776, 75786, 75746, 75750, 72305, 75871 and 75748. The works are marked "R. W. Co., Rockford, Ill." and are numbered 407245, 407316, 407333, 407324, 407338, 407363, 407329 and 407284.

Assistant Chief Driscoll has wired the Brooklyn Watch Case Co., who made the cases, to see if they can tell to whom they sold the cases, and he also wired a Chicago jobbing house, where Kennedy claimed he purchased the works.

E. G. Kay has opened a jewelry store at 510 Main St., Quincy, Ill.

**The Precarious Situation of Kimberley and Its Diamond Mines.**

[New York Herald.]

LONDON, Dec. 23.—A very general impression prevails in the city that Kimberley will yet succumb to Boer besiegers. An officer of the British South African Company, who has an intimate knowledge of South Africa, in expressing this belief, declared that if the Boers captured Mr. Cecil Rhodes they would shoot him.

Nowhere more than on the Stock Exchange does the lack of information as to the operations cause extreme nervousness. It is realized that if Kimberley falls De Beers mines shares and interests will shrivel to nothing, while the Chartered Company's vast issues will lose what little bottom they have left.

**Fear of Business Embarrassment Urges Charles H. Schiller to Suicide.**

UTICA, N. Y., Dec. 25.—Charles H. Schiller, a well known jeweler, shot himself this evening as a result of bad holiday trade. He had been in business more than 15 years. Three years ago his business fell off, and last June New York creditors pressed claims. Schiller partially met his obligations and relied on good holiday trade, but this disappointed him.

Mr. Schiller reached home at 7 o'clock. He passed his family in the dining room and went to his bedroom, where he killed himself. He recently built a home costing \$12,000, which is heavily mortgaged, and had purchased a large holiday stock. On several occasions he had threatened to kill himself. He leaves a wife and seven children.

**Burglar Captured in Flagrante Delicto.**

LA CROSSE, Wis., Dec. 20.—The police captured a burglar while he was in the act of going through M. N. Grasby's jewelry store. He was seen to enter the store by a neighbor, living on the opposite side of the street. The police were notified and three officers went to the rear door, where they found a piece of glass broken. The door was locked, but was forced open. A thorough search of the building was made, and the burglar was found hiding under a table in the corner. He had his pockets filled with watches and jewelry. The safe had been tampered with, but no money was missing. The burglar gave his name as Max Gorger, and said he came here from Austin, Minn.

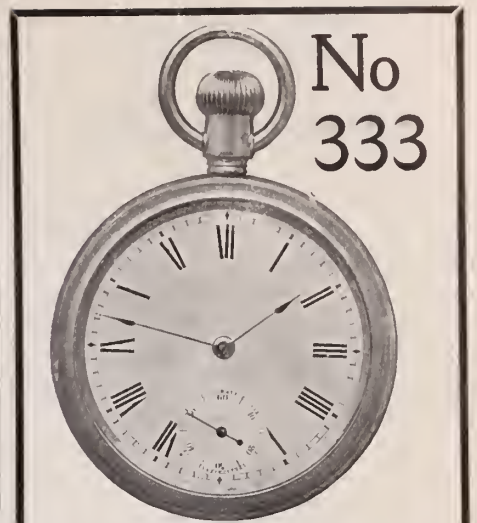

*No watch ever made has sold as well as No 333*

It is the only nickel watch that comes anywhere near the style and beauty of the fine gold cases:

It is 14-size and modeled so that it does not bulge out the pocket:

It has a jeweled movement, is thoroughly tested and carries the same guarantee of accuracy as we give all our watches:

It is the popular size for men, yet not too large for a boy:

Not dead stock at any season —at this season it is *the quickest-selling article a jeweler can handle:*

Arabic, Roman or Card Dial:

**NICKEL OR GUN METAL.**

*New England Watch Co.*  
WATERBURY, CONN.

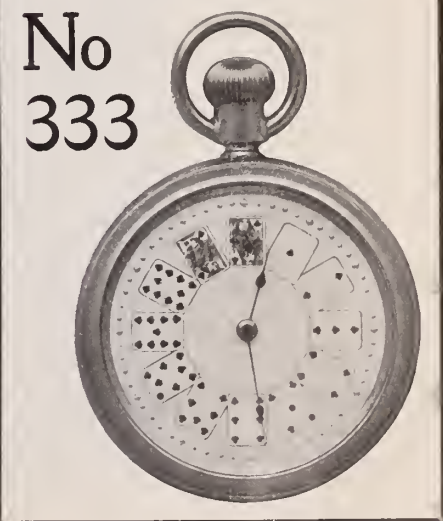

**S. STERNAU & CO.,**

204 CHURCH STREET, NEW YORK.

Manufacturers of **METAL WARES**  
in Brass, Copper and Silver.

**CHAFING DISHES,  
KETTLES, TRAYS,**

Crumb Trays and Scrapers, Bread Baskets, Etc.

CATALOGUE ON APPLICATION.

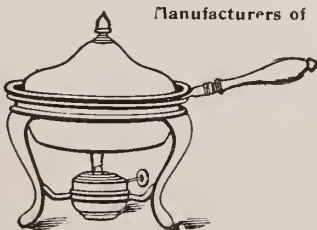

# Minimize Competition

and you can increase your profits. If you handle **Bell Gold-Filled Watch Cases** you can avoid competition in this line. You can control your own designs, exclusively. No other case on the market can compete with them in quality, beauty and finish. Write for full particulars.



Remember, any special design, emblem, monogram, portrait, etc., that your customer may desire can be engraved for the asking when you

**Buy of the Maker..**

**THE BELL WATCH  
CASE CO.,**

**CINCINNATI, OHIO.**

## WANTED

Volumes of **THE JEWELERS' CIRCULAR**  
of the following years:

**1869, 1870, 1871, 1872, 1873,  
1874, 1875.**

**The Jewelers' Circular Publishing Co.,**

**11 JOHN STREET,**

Corner Broadway,

**NEW YORK.**

### Ezra B. Schofield Dies on the Train on His Way Home.

While returning to New York from Larchmont with his wife on a New Haven train Ezra B. Schofield, jeweler, died suddenly of heart disease. Mr. Schofield had been visiting his mother and seemed to be happy and in good health before he boarded the train for New York. Shortly after the train started Mr. Schofield leaned back in the car and apparently went to sleep. Before the train reached the Grand Central Station he was dead.

The deceased was well known in Maiden Lane as a jeweler who did expert repair work for the trade. He was about 62 years of age and had been for 33 years in the employ of Jeweler Bennett at 33d St. and Broadway. After Mr. Bennett's failure, about four years ago, Mr. Schofield started in business for himself as a manufacturer and repairer of jewelry for the trade, taking an office at 35 John St., which he occupied from that time. He was reputed to be a thoroughly good workman, who understood his trade perfectly, and this, combined with his honesty and pleasant disposition, brought him the respect and esteem of all who knew him. The heart trouble, from which he died, first attacked him 12 years ago. The deceased lived at 48 W. 132d St., from which place the funeral will be held. Besides the widow he is survived by a son and daughter.

### The Slayer of Paul Roehricht Gets a Light Sentence.

SOMERVILLE, N. J., Dec. 26.—The trial of Mrs. Henrietta Fingerhut, who was charged with causing the death of Paul Roehricht, a jeweler, of New York, ended Dec. 23 in a verdict for manslaughter with a recommendation to mercy.

Readers of *THE CIRCULAR* will recall that Roehricht was killed by Mrs. Fingerhut while he was attempting to dispossess her from a home which he had given to her and her husband at Plainfield, N. J. The case occupied all last week and the jury brought in a verdict after deliberating 22 hours. Mrs. Fingerhut took the stand in her own behalf, and testified that Roehricht had tried to induce her husband to set fire to the house to obtain the insurance, and being maddened at his refusal, attempted to force him to leave. When she was in the house alone Roehricht and his lawyer attacked it and tried to break in. Crazy with fright at their attack and at the revolver which the lawyer flourished, she took one herself and fired without aim. This story was confirmed by Mrs. Fingerhut's son and other witnesses. After the case went to the jury a verdict of acquittal was expected by many. To-day Mrs. Fingerhut was sentenced to six months in jail and to pay a fine of \$500. A subscription list is being circulated by persons here to raise money to pay the fine.

Fingerhut and his son who were indicted with the prisoner were exonerated by the verdict of manslaughter and were discharged. Paul Roehricht was for many years a jeweler at 2155 Seventh Ave., New York.

### E. C. Burritt Worked by a Female Penny- weighter.

LA PORTE, Ind., Dec. 20.—Edwin C. Burritt, jeweler, was a few days ago "touched" for a fine three-stone opal ring by a confidence woman. A well dressed young woman came into the store and asked to be shown some rings. Mr. Burritt waited on her and took out several trays of fine jewelry from the showcase and placed them before her. She looked them over quite critically, but did not find just the kind of a ring she desired, and explained that she wanted an opal ring in which she could have two diamonds set. Mr. Burritt then brought out some finer rings, among them a handsome three-stone opal, in which, Mr. Burritt explained, two diamonds could be placed instead of the opals. The piece of jewelry was an exquisite one and the woman was very much taken with it, but when the price was stated she said that it was more than she cared to pay. She then asked to be shown some gold cuff buttons, and it is believed that while Mr. Burritt turned around to pick the tray out of the show window the woman palmed the ring which she had admired so much, for as Mr. Burritt placed the tray of cuff buttons before the woman he hastily looked over the ring tray, and immediately noted the absence of one of the rings, but he was unable to tell which one.

Without being able to tell definitely which ring was missing he was not in position to accuse the woman of taking it, and so tried hard to determine which it was while he showed her the cuff buttons. It took the woman but a few minutes to tell that she could not find what she wanted and she quickly left the store. After she was gone it took Mr. Burritt but a few seconds to determine which ring was missing, and though the woman had just left the store a person who made a hasty trip along Main St. was unable to catch sight of the confidence woman. Mr. Burritt, considerably, immediately notified the other jewelry stores of the game worked on him and furnished them with a description of the woman.

### THIS LOOKS LIKE THE SAME WOMAN.

SPRINGFIELD, Ill., Dec. 20.—A clever attempt to steal a diamond ring from the jewelry store of George W. Chatterton was made yesterday afternoon by a woman. She was about to leave the store with the ring when she was apprehended by Mr. Chatterton. The ring, which was valued at \$75, was returned to the jeweler, and the woman begged so piteously to be released that Mr. Chatterton gave her her freedom. Her identity was not established.

The woman entered the store about 4 o'clock. She was neatly dressed and did not act in a suspicious manner. She asked to be shown some diamond rings, and one of the clerks called upon Mr. Chatterton to wait upon her. A number of rings were taken out of the show case for her to examine. She looked at them and laid each one down carefully. When she thought Mr. Chatterton was not watching her the woman took the ring valued at \$75 and

placed it in her handkerchief. She looked about the store for a short time and then started to leave. Mr. Chatterton had watched every movement the woman made. He saw her take the diamond ring and wrap it in her handkerchief, but thought that she intended to purchase it. When she started to leave the store, however, he understood her design and called to her to bring back the ring. The woman paid no attention to him and hurried towards the door. Mr. Chatterton was too quick for her and caught her just as she was about to escape with the diamond.

The woman is probably a diamond thief who had come to Springfield to operate during the holidays.

A new departure in link buttons is the "Bell Post" construction recently patented by John T. Mauran Mfg. Co., makers of gold jewelry, Providence, R. I. A great advantage possessed by buttons made in this way is that they will not bend or break even under the most trying test to which they may be put. The bean end and the bar cannot break apart, as they are of one continuous piece, and the wide bell at the other end of the post gives a very strong base to which the fronts are fastened. With this construction the manufacturers claim a saving in labor of 50 per cent, and, therefore, a corresponding reduction in price. The buttons are made in 100 new styles in solid gold, and every pair bears the guarantee of John T. Mauran Mfg. Co., which, based on 50 years of success, is all that can be desired.

#### Death of Luther F. Brooks.

TOMAHAWK, Wis., Dec. 20.—Luther F. Brooks, of Boston, Mass., died of heart failure at the Mitchell, this city, to-day,



THE LATE LUTHER F. BROOKS.

aged 67 years. He was the father of Hall L. Brooks, a leading lumberman here. He was here on a visit. Mr. Brooks was a former manufacturing jeweler in Boston. He was formerly of Brooks & Pike, and was universally known to the jewelry trade. The body will be taken to Cambridge, Mass., for burial.

Vanderpool Brothers, Rochester, N. Y., have leased a larger store at 174 State St., and will remove their stock thither as soon as the necessary alterations and fitting up can be completed.

#### Charles A. and Otto Klie Assaulted by a Discharged Employee.

COLUMBUS, O., Dec. 23.—Charles A. Klie, president of the New Columbus Watch Co., and his brother, Otto Klie, were the victims of a bold daylight hold-up this afternoon when both of them were shot and wounded. The man who did the deed was Frank Knorr, an employe who had been discharged some time ago and who claimed he had become desperate because he was out of money.

Otto Klie had been to the bank and had secured several thousand dollars with which to pay the men this evening. He had alighted from the car and was walking down Thurman St. toward the factory, with the money in an ordinary box, when he was attacked by a man who seemed to be a tramp. The man struck his victim on the head with a beer bottle filled with catsup, but it failed to do its work and only put Mr. Klie in a good fighting mood. He called for help, however, and his brother, Charles, who was not far away, heard him and went to his aid. Seeing that he was in a close place, Knorr drew a revolver and began to fire. One of the bullets took effect in Charles Klie's neck and one in Otto's right arm. In the scuffle a false beard was torn from Knorr's face and his identity was at once established. The man was overpowered and sent to the police station. There he seemed very penitent and regretted what he had done.

Neither of the wounds now seem to be of a dangerous nature, and the men will likely recover without difficulty. The affair caused considerable excitement.

**WALTHAM WATCHES**  
ARE CARRIED ALL OVER THE WORLD

**Death of Albert Cushing Titcomb.**

SAN FRANCISCO, Cal., Dec. 19.—It has just been reported here that Albert C. Titcomb, who was for many years in the wholesale jewelry business in this city, died in Newburyport, Mass., on Dec. 14.

**LAST HONORS PAID TO THE DECEASED.**

NEWBURYPORT, Mass., Dec. 19.—It was with deep regret that his many friends learned of the death of Albert Cushing Tit-



THE LATE ALBERT CUSHING TITCOMB.

comb, a former jeweler and prominent resident of this city, whose funeral took place yesterday afternoon. Mr. Titcomb, who was for many years a leading jeweler of San Francisco, Cal., was also prominent as a director in the Towle Mfg. Co. here. Mr. Titcomb's death occurred Dec. 14 at 1 o'clock A. M. and was wholly unexpected. The evening before he had attended a "smoke talk," given at the Dalton Club, and was apparently in the best of health and spirits. Shortly after retiring he awakened about 1 o'clock, complained of nausea and pains in the head, and then became unconscious. Though his physician did what he could for him, he sank rapidly and died before other physicians summoned could arrive.

Mr. Titcomb was one of Newburyport's most prominent citizens, having been an Alderman and a Mayor of this city. He was born here July 31, 1831, and his family was one of the oldest and most prominent in the city. After graduating from school at the age of 14 years he went to Boston, where he was employed in the dry goods business, and four years later sailed for San Francisco during the gold fever. He spent some time at the mines and then went to Central America, engaging in the hotel business and coffee trade. He was still a young man when in 1851 he re-

turned to his old home and entered a machine shop. He followed this by becoming a traveling salesman for a Providence jewelry house. After leaving this firm he was for a while in the jewelry business in the south, but came north at the time of the Civil War. After the war he established the firm of Titcomb & Williams, wholesale jewelers, San Francisco, and within a few years he bought out his partner and carried on the business alone for 12 years. While in San Francisco he was interested in the jewelry business in the islands of St. Thomas and Curacao.

Early in the '80s Mr. Titcomb returned to Newburyport and soon became active in the commercial world of this city. He became interested in several concerns and was finally honored by his townsmen in being elected Alderman in 1888, and was elected Mayor for the term of 1888-1889. Mr. Titcomb became a director in the Towle Mfg. Co., in the Merchants' National bank, the Five Cents Savings bank, besides being identified with the Public Library, Dalton Club, American Yacht Club and of various similar institutions of a public character. He was prominent in the religious work of this town and was a member of a number of religious organizations. He was a Mason and belonged to the St. John's Lodge, King Cyrus Chapter, the Newburyport Commandery of Knights Templar and other similar societies, and besides was a member of the Sons of the American Revolution.

The deceased was twice married, his first wife dying in 1882 and leaving one son, William Graves Titcomb. He married again in 1884 and two children survive the union. The funeral services which were held in the late residence of the deceased, 77 High St., yesterday morning, were largely attended by a host of friends and associates, who gathered to pay a last tribute of respect to the man and citizen who stood so high in the esteem of his fellow townsmen. The services were conducted by the Rev. Arthur H. Wright, of St. Paul's Episcopal Church, Rev. Dr. H. C. Houghby and Rev. L. A. Pope.

**Jewelers' Gold Bars Withdrawn and Exchanged.**

*Week Ended Dec. 23, 1899.*

The U. S. Assay Office report:

Gold bars exchanged for gold coin....	\$135,394.65
Gold bars paid depositors.....	45,035.92
Total .....	\$180,430.57

Of this the gold bars exchanged for gold coin is reported by the Sub-Treasury as follows:

Dec. 18.....	\$26,557
" 19.....	36,540
" 20.....	15,795
" 21.....	.....
" 22.....	.....
" 23.....	15,597
Total .....	\$94,489

**Chicago's Department Store Tax Ordinances Declared Void.**

CHICAGO, Ill., Dec. 22.—The Illinois Supreme Court this week declared void the two department store ordinances of the city of Chicago, those relating to the sale of meats and liquors where dry goods are sold. The opinion is of so broad a scope that little ground remains for action by the anti-department store associations, of which there are a number in the city.

The decision was rendered in the cases of Charles Netcher against the people. The Supreme Court sustained the judgment of the Criminal Court of Cook County. One of the ordinances provided that meats, fish, butter, cheese, lard, vegetables and other provisions should not be sold or exposed for sale by any firm or corporation in the same building where dry goods, clothing, jewelry, or drugs are sold. The other forbade the sale of malt or fermented liquor in such a place. Netcher is proprietor of the Boston Store. He was arrested for violating both of these ordinances, and a Justice of the Peace fined him \$25 and costs in each case. He took an appeal to the Criminal Court of Cook County, and that tribunal held the ordinances void. The case was then brought to the Supreme Court by the prosecution.

The opinion of the Supreme Court is sweeping. It is held that its charter does not give the city of Chicago the right to make such stringent laws; that the city is only empowered to make such regulations concerning the sale of provisions as may be necessary for the preservation of health or the prevention of disease. The Court holds that the ordinance is an attempted interference on the part of the city with the right granted the defendant by the constitution of the United States and by the constitution of Illinois to acquire property and to own and use it. To deprive an owner of the right to expose and to sell property, the Court holds, is to deprive him of property. The second ordinance is held to be purely an arbitrary restriction, not having any connection with and not tending in any way towards the protection of the public against the evils arising from the sale of intoxicating liquor. Such a protection was not the object in view when the ordinance was passed, and the attempted discrimination is declared to be illegal and in violation of the rights of the defendant.

The Netcher case was a test. Arrests had been made also at the Fair, A. M. Rothschild & Co.'s, and Siegel, Cooper & Co.'s, and fines of \$25 and costs had been imposed in each.

The Rockford watch factory, it is reported, is to be reorganized and the factory started up full force soon.

The  
**Mercantile National Bank**

OF THE CITY OF NEW YORK,

BROADWAY AND DEY STREET,

Solicits Accounts from the Jewelry Trade.



### Connecticut.

Another story is to be added to the factory of the Simpson Nickel Co., Wallingford, Jan. 1.

The Waterbury Clock Co., Waterbury, will erect an extra, new, large building for their business.

N. L. Bradley, of the Bradley & Hubbard Mfg. Co., Meriden, has returned from Chicago.

The insurance on the jewelry stock of George J. Fisher, Middletown, damaged by fire on the night of Dec. 15, has been settled.

Robert S. Gardner, Ansonia, who has been critically ill with typhoid fever, is now able to sit up in a chair and is recovering quite rapidly.

The Middletown Silver Co., Middletown, received two large orders last Monday from western dealers, which will require at least four weeks to fill.

The amount of insurance carried on the case shop of the E. N. Welch Mfg. Co., Forestville, burned out as reported last week, is only \$50,000, being much less than the loss, apparently. The company intend to rebuild at once.

The E. & H. T. Anthony Co., New Haven, manufacturers of cameras and photographic supplies, have sold out their hand camera business to the recently incorporated combination of photographic manufacturers in Rochester, N. Y. The sale will go into effect Jan. 1.

The factory of the New Haven Clock Co., New Haven, narrowly escaped a severe fire Dec. 19, at 5.30 o'clock p. m. A bucket of varnish in too close proximity to a gas jet was the cause. It became ignited and in a second the flames had overrun a corner of the fourth floor. The employees were prepared for the occasion. Before the firemen reached the floor two buckets of sand and an old overcoat had extinguished the blaze.

C. Tiffany, jeweler, South Manchester, who for the past 18 years has occupied a store in the old Cheney block, has moved into his handsome new store in the new Cheney block. The old block was burned out in November, 1898, and Mr. Tiffany has carried on business in temporary quarters during the past year. In the new store he has a roomy workshop, a nicely furnished optical room and a large sales-room, with all oak fixtures. We wish Mr. Tiffany success in his new business home.

### Columbus, O.

#### THE HOLIDAY TRADE.

The holiday business of the jewelers of this city came fully up to their most sanguine expectations, and in some cases far beyond. There is really no comparison with other years, although the weather for a few days was very unfavorable. The goods purchased were of a splendid quality for the most part, and as a consequence the profits on each sale amounted to something. There were more watches and diamonds sold the last week of the holiday season than in the same period for many other years, and it is doubtful whether there were ever so many sold in the same length of time.

Following are the expressions of some of the leading dealers:

F. R. Cross & Co.—“The business for the immediate holiday season fully up to expectations. For the entire season we are away ahead.”

Frank M. Deinlein.—“Our trade has gone far ahead of what we had counted on and we are well pleased at the result. It is said that trade in all

lines has been better this season than it was in 1893.”

Frank F. Bonnet.—“Things have gone with a whirl and we have hardly had time to see where we are, but there is no question but that we are far ahead of last year.”

Harrington & Nonnemacher.—“We have had all we could do and the business has been very good. I have made no endeavor so far to see how we stand, but are ahead of anything during the holiday season for several years past.”

Haines & Oberer.—“We have had an elegant trade and are thoroughly satisfied with what we have done. If we do as well every season we will not complain.”

Bancroft Bros.—“Every day this week has run far ahead of the corresponding day last year. The weather was not favorable for a few days last week, but we have had a fine business.”

J. B. White.—“Our trade both in jewelry and optical goods has been good during the entire holiday season. When we close the holiday sales we will at once arrange our store for the optical work which we shall hereafter make our exclusive business.”

Albert H. Bonnet (wholesale).—“We have been very busy right up to the last day, and have hardly been able to fill our orders. This has been a very good Fall and Winter with us.”

F. L. Wirschinger.—“We have had a very fine trade. Many watches and diamonds have been purchased this year for holiday presents.”

Bancroft Bros. have put in a new wall case, which improves the appearance of the store.

Carl Baron, watchmaker and jeweler, claims to have discovered a rapid and simple method for restoring discolored turquoise to its natural color, no matter in how bad a condition it may be. He has been experimenting for some time, and has the method now so that it does the work perfectly.

In the item under this department last

week, regarding the affairs of Philip H. Bruck, it was stated that he was interested in the New Columbus Watch Co., though his embarrassment had no effect whatsoever on the affairs of that company. The New Columbus Watch Co. inform THE CIRCULAR that Mr. Bruck has not now and never has had any interest in the New Columbus Watch Co. or in the old company, but simply was the receiver for the old company.

### Omaha.

The case against G. C. Porter for assault on Albert Edholm has been dismissed.

The Iowa Optical Co. have removed from S. 14th St. to the corner of 17th and Douglas Sts.

Mawhinny & Holliday have given a silver loving cup to the Y. M. C. A. as a prize for athletic contests.

Trade has been better this holiday season than ever before in Omaha, and higher priced goods were sold than in previous years.

Omaha has been overrun with shoplifters during the holiday season. A woman giving her name as “Brown” was arrested in the Boston Store for stealing jewelry. When searched a pocket as large as a grain sack was found within her dress, and in this a number of articles of jewelry had been stowed away. She refused to give the officers any clue as to whom she was and she was released after being fined \$10 on the charge of petit larceny.

WE desire to call the attention of those buying early this season to our large and complete line of guard chains suitable for the lorgnette, watch, fan, muff, purse, or for use as an eye-glass chain, and especially to the many new patterns of chains and slides we are showing. We have borne in mind the tendency toward heavier chains, and are showing some patterns which at this date we believe cannot be duplicated elsewhere.

**B. A. BALLOU & CO.,**

Providence, R. I.

## DE BEERS CO. AND SYNDICATE

THE RELATIONS BETWEEN THE TWO ORGANIZATIONS—MEMBERS OF THE SYNDICATE.

BY REGINALD FOSTER.

THE relations between the De Beers Consolidated Mines, Ltd., and the Rough Diamond Syndicate have been for some years a matter of conjecture in the jewelry trade, and the subject of many statements in newspapers. These statements vary in important details simply because they are founded upon "information received" from different diamond dealers. Probably no two men would agree in naming the individuals or firms composing the Syndicate, though all would mention one or two of the more prominent. So far as I know the report published in THE CIRCULAR of March 29 last contains the fullest list yet published on either side of the water. The secret of the "inside" arrangements between the Company and the Syndicate has been well kept, but some information can be gleaned from official sources which supplements and to some extent confirms statements made by persons supposed to be "in the know."

A mistaken impression has been current to the effect that the Syndicate and the consolidation of the mines at Kimberley are part and parcel of the same arrangement. This is not so, the Syndicate being a creation of much later date. Originally the four principal mines at Kimberley—De Beers, Kimberley, Du Toit's Pan and Bultfontein—were worked by a multitude of individual miners, probably numbering some thousands, working separate claims. As the importance of the fields became more manifest and the difficulties of mining increased through the accumulation of water in the lower workings and the fall of reef upon the border claims, concentration and union of interests became imperative. There was a mining board which acted over the area and spent a considerable amount of money in general improvements, but the natural and inevitable result was the formation of companies under the limited liability principle to work a number of claims under one management. This simplified matters, but in each of the mines there remained a number of distinct interests which not only conflicted with each other in the processes of mining, but also competed in selling the product. The open mining system also became, through the enlargement of the pits and the difficulties in relation to water and reef slides, impracticable, and in 1883 the Kimberley mine was in consequence temporarily closed. The introduction of the underground system necessarily followed.

Without going into too great detail, it may be stated that the chief interests in the De Beers mine were consolidated into the De Beers Mining Co., and the principal claims in the Kimberley mine bought up by the Kimberley Central Co., a French company controlling the remainder. The De Beers Consolidated Mines, Ltd., were established on March 13, 1888, with a nominal capital of £100,000. On March 31 a scheme was adopted to amalgamate with the De Beers Mining Co., and this was followed by the purchase of the Kimberley mine and the French com-

pany and of controlling interests in the Du Toit's Pan and Bultfontein mines. The consolidation practically amalgamated some 11 or 12 separate companies. The nominal capital was finally fixed at £3,950,000. In addition, about 4½ millions in debentures was issued or taken over. About a million in debentures has since been redeemed. The cost of the properties was roughly as follows: De Beers, £4,480,000; Kimberley, £5,338,000, and Du Toit's Pan and Bultfontein about £4,500,000, a total of £14,318,000; whereas the market value of the shares in the different companies was, according to Mr. Barnato, over 23 millions. There remained several small outside concerns which would not come to terms or were too unimportant to be considered. One of the better ones, the Premier, on the Wesselton Estate, was taken over in 1892.

In the early years of the new company the produce of the mines was sold to a number of individual buyers located in Kimberley. Mr. Barnato stated that at one time there were 300 to 400 brokers and dealers earning on an average £1,000 a year. Some years earlier, when two of the old companies who shipped their diamonds had accumulated a heavy stock, a "ring" of buyers was formed in Holland to hold back purchases, with the result that the stock had to be sold at lower prices. In Stock Exchange parlance, this Syndicate was one of "bears," whereas the modern Syndicate consists of "bulls."

A suggestion was made in 1889 that a third of the product should be shipped home, but the idea fell through. Under these conditions the rough sold in 1889 at from 27s. 6d. to 30s. per karat. Before the amalgamation, from 1883 to 1888, the average price of diamonds at Kimberley fluctuated from 19s. 6d. to 23s. per karat, and for the first year after only 19s. 8¼d. per karat was realized for the De Beers product. The average for 1889-90 was 32s. 6¼d. per karat, and for 1890-1 29s. 6d.; since then it has not exceeded 29s. It may be noted here that work was stopped in the Bultfontein and Du Toit's Pan mines in 1889; the former mine has been reopened recently. The high prices current in these earlier years were no doubt principally owing to the good quality of the Du Toit's Pan diamonds, which at one time fetched as much as 55s. per karat. In the early years of the Company it was estimated that one-third of the diamonds produced was bought by America, and the fall in prices in 1892 (from 29s. 6d. to 25s. 6d.) was occasioned by the state of American finance.

The inception of the Syndicate practically arose from this fact. Complaints were made that some of the directors, being diamond merchants, had a dual interest, being at the same time sellers and buyers. They included some of the largest shareholders in the company, representing something like a million and a half of money. As a safeguard, a Diamond Committee were formed of directors having no direct or indirect interest in diamond purchases, to whom devolved the sale of the stones. Their method was to take all the buyers in turn. When the price was highest, America collapsed. Here followed a contest between the Diamond Committee

and the diamond buyers and the latter won. The above facts are taken from Mr. Rhodes's speech at the annual meeting for 1892-3. In his own words, "Then a powerful Syndicate came forward and met us offering a price for our stock, and so we got rid of our diamonds, but at a much lower rate. The real fault was that America failed us." The same thing occurred upon a subsequent occasion, and apparently the Syndicate has held sway ever since. The Diamond Committee referred to above sell after consultation with the London Board. The arrangement as to the regular taking of the production came later.

Before discussing the personal composition of the Syndicate, it may be well to note some particulars of its dealings with the Company. The first transaction consisted of over two millions sterling purchased at one time. B. I. Barnato (a life governor) was one of the principal members of the Syndicate at that time. The price paid per karat was not disclosed, but the total sales for the year equaled £3,240,000, the rate being a little over 29s. per karat. A further sale *en bloc* took place later on. From July 1, 1895, to Dec. 31, 1896, the Syndicate contracted to take about 200,000 karats a month at 27s. 6d., the Company being also allowed to sell a limited quantity beyond this. This contract appears to have been renewed at the same price for a slightly increased quantity (208,000 karats a month) up to the end of 1897. In 1897-8 the Premier mine was started again, but the price obtained for the stones from this mine was only 20s. 6d., whereas the figure for the other mines was 26s. 8d. This contract expired at the end of last year, and the particulars of the new one have not yet been officially published. It has been stated, however, that the price fixed was an all round one of 32s. 6d. per karat. The Bultfontein production has now to be reckoned with, and the report for the year ended June 30 last may somewhat modify the above statement.

As regards the personnel of the London Rough Syndicate, it should be distinctly understood that, as there is practically no official information available beyond chance references in speeches at De Beers meetings, the following details cannot be guaranteed. The Syndicate is not a registered company, and the De Beers concern itself, although a limited liability company, is not registered in this country, but in Cape Colony. Enquiries have not shaken the substantial accuracy of the list of firms comprising the Syndicate published in THE CIRCULAR of March 29 last. Some authorities add one or two names to the list, *e. g.*, it seems probable that Levenson, Forster & Co. are interested. The correct names of the firms mentioned are as follows: Louis & Alfred Abrahams, Wernher, Beit & Co., Joseph Bros., Anton Dünkelsbühler & Co. and Bernheim, Dreyfus & Co. All these firms have offices in the neighborhood of Hatton Garden. The Messrs. Abrahams, Joseph, and Bernheim, Dreyfus & Co. are described as diamond merchants. Wernher, Beit & Co. and the Dünkelsbühlers have also city offices in their capacity of "merchants," which is probably an euphemism for "financiers,"

and the Dünkelsbühlens are brokers. The well known B. I. Barnato, a leading member of the earlier combination, died in 1897, and his firm, Barnato Bros., are not strictly diamond merchants, but it is probable that they are still financially interested in the Syndicate. Alfred Beit and Julius Wernher, of world-wide fame as financiers, Rand gold mine owners, etc. (commonly called the "Eckstein Group"), are life governors of De Beers. Mr. Beit was one of the promoters of the consolidation and is probably correctly described as the richest man in South Africa. Julius Wernher, his partner, was elected a director in 1890. Isidore Dreyfus (of Bernheim, Dreyfus & Co.) is his "alternate" director. Lt. Col. D. Harris, another director, is interested in the Syndicate, probably representing the Barnato group. It may be noted that on one occasion he also represented L. & A. Abrahams at an annual meeting, but this may be merely an accidental combination. The connection of the other firms with the directorate is not clear, but the whole of the names appear in the lists of shareholders. The dual interest of these firms is abundantly evident. Mr. Beit is the leading spirit. Mr. Rhodes stated in 1893 that the diamond merchants on the board of directors represented a million and a half sterling. As is well known, the Rothschilds have a large interest in De Beers (their representative on the directorate being Carl Meyer). Messrs. Bernheim, Wernher, Dreyfus and D. Harris are also directors of the Jagersfontein Company.

It should be noted that there are in all 17 directors of the De Beers Company.

The sorting and parceling of the stones are primarily done at Kimberley. The stones vary, of course, greatly in size and quality, but what are called small stones represent a third of the output. Parcels used to be made up of 1,000 karats and upwards, but the opinion is generally expressed that the smaller parcels are not now made, and the result is that many smaller buyers are shut out. The sales are conducted by the brokers to the Syndicate, M. J. Levy & Nephews, of Holborn Viaduct.

The position of the Syndicate appears to be as well assured as ever. Recently there was some renewal of the talk of a competing combination, but the rumor lacked confirmation. Unless strongly supported within the De Beers concern (*e. g.*, by the Rothschild interest), there could be but little chance of success, and from the jewelry trade standpoint it would merely mean a change of masters.

### Indianapolis.

Chain bracelets, silver hearts and 7-jewel movements are a few of the articles that have been most called for, and the supply has not been equal to the demand.

The high water mark of trade of 1892 was more than reached this year. Buyers in the city the week before Christmas included: C. L. Rost, Crawfordsville, Ind.; E. M. Willhite, Danville, Ind.; A. R.

Cooper, Mooresville, Ind.; F. C. Sheldon, Shelbyville, Ind., and scores of others.

Saturday night, Dec. 16, the rooms of the Columbia Jewelry Co., 17 S. Meridian St., which was robbed about a month ago of \$2,500 worth of jewelry, was again broken into. About \$12 worth of cheap jewelry was found outside of the safe, and this was taken. Louis Haase, manager of the company, is unable to give any clue to the burglars. Effort was made to enter Ikko Matsumoto's jewelry store, which adjoins the Columbia Jewelry Co.'s rooms, but heavy iron bars at all the doors and windows proved—as they have done before—too much for the burglars.

One of the great clock weights in the tall steeple of the Union station fell at 8:30 o'clock on the evening of Dec. 14, caused by the breaking of the cable. The clock had about run down, and the weight was only 20 feet above the top floor, but it went through three floors and dropped into the office of the chief claim agent of the Pennsylvania Railroad. In the smoking room below were a number of men waiting for their trains; the heavy jar knocked off the plastering and badly frightened them. No one was injured, but the damage was considerable to the clock and the building. The weight is a mass of iron weighing 700 pounds, and this is the second time it has crashed through three floors.

Chas. Kelley, of Myrtle Creek, Ore., will open a jewelry store in a new building in Roseburg, Ore.

Now Ready For Delivery.

Third Edition

# WORKSHOP NOTES

For

JEWELERS and WATCHMAKERS.

Being a collection of the latest practical receipts on the manufacture and repairing of watches and clocks and on the various processes entering into the manufacture and repairing of jewelry, as coloring, polishing, enameling, annealing, oxidizing, etc., in short, a thorough compendium of the numerous mechanical departments of the jewelers' and watchmakers' shop. ❀ ❀

Containing 300 pages. (Size, 7½ x 10½ inches), Bound in Cloth, Stiff Covers.

This book is the most useful, comprehensive and perfect publication of the kind and should be in the hands of every jeweler and watchmaker in the country. ❀ ❀ ❀ ❀ ❀

PRICE, \$3.00.

... PUBLISHED BY ...

THE JEWELERS' CIRCULAR PUBLISHING CO.,

11 John Street, cor. Broadway, New York.

LUDWIG NISSEN & CO.

LUDWIG NISSEN & CO.



Fig. 1. Miner at Work Drilling Rock Before Blasting.



Fig. 2. Tunnel with Cart Accumulating Blue Ground.



Fig. 3. Carts Hauling Blue Ground to the Floors.

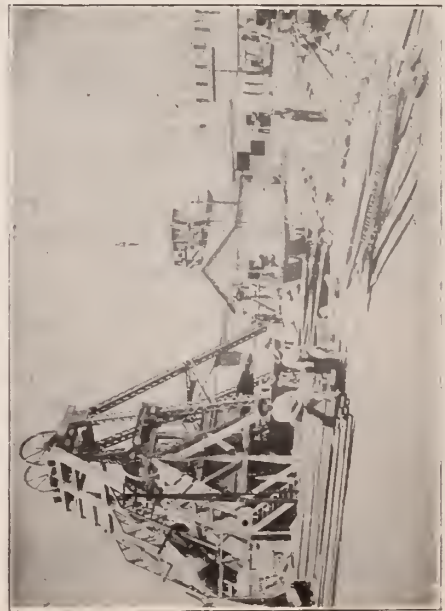

Fig. 4. Machinery for Hauling Trucks of Blue Ground to the Floors.

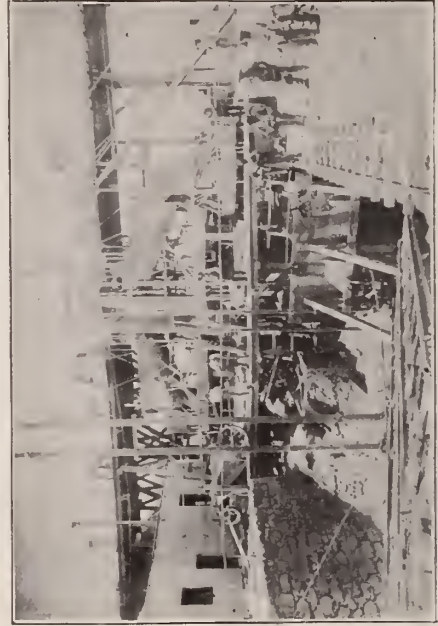

Fig. 5. Washing Machine (Front View) Separating Sand and Earth from Solid Material.

# The Kimberley Diamond Mines.

**ILLUSTRATIONS  
SHOWING SCENES IN THE  
MINES AND  
PROCESSES OF MINING.**

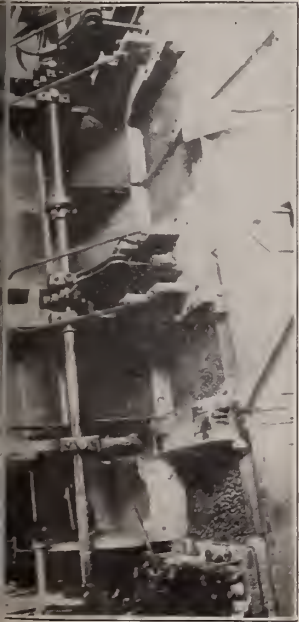

Fig. 6. The Pulsator Sorting Diamondiferous Stuff into Four Sizes.

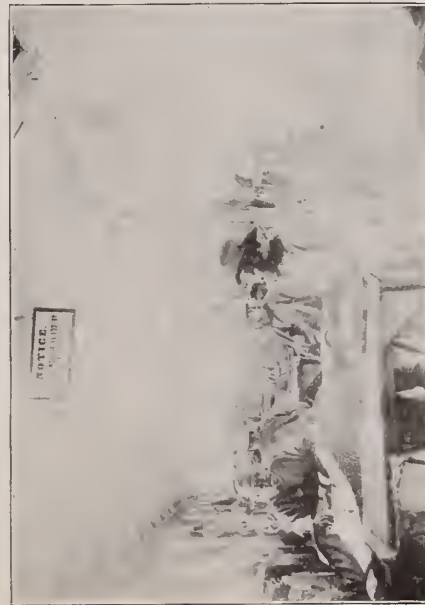

Fig. 8. Assorters (Natives) Sorting for Possible Oversights by First Assorters.

Fig. 7. Assorters (Whites) Doing the First Assorting from the Gravel.



Fig. 9. Part of Mine After a Big Fall of Reef.

**STATISTICS.**

Population of Kimberley, . . .	25,000
European Employees at Mines, . . .	1,800
Native Employees at Mines, . . .	11,000
Capital Stock of De Beers Co., \$19,197,000	
Chairman of Company, . . .	Cecil Rhodes
Yearly Output of Blue Ground, . . .	1,500,000 Loads
Size of Load, . . .	16 Cubic Feet
Average Yield of Load, . . .	1 1/2 K.
Mines Discovered, . . .	1867

Copyright, 1899, by The Jewelers' Circular Publishing Co.



Fig. 10. Miners at Play in the Compound.



This double page, as appears inside of border, will be furnished,

**FINELY PRINTED ON HEAVY PAPER,  
SUITABLE FOR FRAMING,**

to our friends and customers in the trade upon application.



This double page, as appears inside of border, will be furnished,

**FINELY PRINTED ON HEAVY PAPER,  
SUITABLE FOR FRAMING,**

to our friends and customers in the trade upon application.

COMPLIMENTS OF  
**LUDWIG NISSEN & CO.**  
Importers of  
**DIAMONDS,**  
18 JOHN ST., N. Y.

### Providence.

The manufacturers are now experiencing a little lull in their business as a result of Christmas. It was expected and had been provided for.

Ryder & Daughaday is the name of a new firm who have started in business as manufacturing jewelers at 94 Point St., in the Simmons building. They manufacture rings and novelties.

S. O. Bigney & Co. made a Christmas present to their employes in the shape of reserved seats at one of the local theaters. Nearly 100 women and men took advantage of this generous action of the firm.

John F. Branigan started Dec. 19 for New York, where he will take up the duties of traveling salesman for J. M. Fraser & Co., this city. His initial trip will take him as far as St. Louis. He was formerly with Williams & Payton.

The local jewelers were compelled to keep a sharp eye out for shoplifters during the holiday season. The Tilden-Thurber Co. were visited by one woman who attempted to purloin a pocketbook. She was arrested and arraigned in the District Court.

Within a very short time S. O. Bigney & Co. will vacate their factory in the Manufacturers' building for their new factory in Attleboro. It is understood that T. E. Bennett & Co. will occupy the quarters which the first mentioned firm will vacate. The Bennett firm will thus more than double their floor space.

Among buyers who have visited local manufacturers recently were Mr. Warrener, of F. M. Pudan & Co., and W. S. & D. Buxton, Springfield, Mass.; L. Seligman and E. Cohen, New York; K. Landau, Chicago; I. Groh, Indianapolis, Ind.; Mr. Pfaelzer, of Pfaelzer Bros. & Co., Philadelphia, and S. Deutsch, of the Jewelers' Mfg. Co., Cleveland, O.

On Thursday night the first in a series of mass meetings was held under the auspices of the Jewelers' Protective Union, of this city, the newly organized body of working jewelers, now a branch of the American Federation of Labor. The president, J. F. Carroll, in his preliminary address, referred to a number of reforms that the jewelers are seeking to bring about, one of which was the dropping of the "obnoxious term 'bench hands.'"

### The Attleboros.

Last week Wilson & Co. opened a temporary retail store in their Attleboro factory.

G. K. Webster contemplates the installation of new and more powerful engines in his new factory.

Lenau, Thomas & Co. are adding a 25x50 two-story section to their factory, especially intended for bench and press work.

J. C. Cummings & Co. are about to open a New York office. It is also reported that a new man is to be added to the force of traveling representatives of the house.

Oscar Kurtz, with E. Ira Richards & Co., and S. W. Rhodes, foreman for T. G. Frothingham & Co., left the first of last week for a pleasure trip to and about New York.

The manufacturing house of Burtonwood & Wheelock dissolved Saturday, Edwin Burtonwood withdrawing. The affairs of the house will be continued as Henry H. Wheelock & Co.

William H. Smith, of Smith & Crosby, while demonstrating to a workman the manipulations of a machine, plunged a part of the device through his own hand, making a very serious wound.

Samuel E. Fisher, William F. Maintien, W. S. Metcalf, Charles Stanley and Roswell Blackinton, well known jewelers, appear in the new list of officers of the North Attleboro Masonic lodge.

Grover, Son & Co. are reported by the local press as being about to move a mile or more from the center of Attleboro, up into the section of the Robinson building being vacated by F. H. Sadler & Co.

The working force in the Attleboro express office declare the shipment of goods by the jewelry manufacturers the past season far exceeded any other season in their recollection, not excepting the most prosperous years of the past.

Before the date of the next issue of this paper the whole Bigney building in Attleboro will be filled with tenants and in complete running order. All last week and this week were periods of moving for the numerous firms who took quarters there.

G. K. Webster, C. M. Robbins and a number of other houses remain closed between Christmas and New Year's day. The operatives have been on duty 10, 12, and in some factories 15 and even 24 hours a day for eight months, and they are little short of worn out.

J. B. Ellis & Co. have taken the second floor of the Walter E. Hayward factory building, Union St., Attleboro, moving there from their old quarters in the F. E. Goff building, which sheltered them after the big fire of 1898. It is a quadrupling of their floor space and accommodations.

Saturday was an idle day with the 12 jewelry factories dependent for power on the big steam plant owned by Joseph M. Bates and located behind the Steam Power building, Railroad St. The rod controlling the cut-off valve in the steam chest broke, disabling the whole group of factories.

E. Ira Richards, son of the head of E. Ira Richards & Co., of North Attleboro, was given the position last week of western traveling salesman for the Horton, Angell Co., Attleboro. Thursday he started off on his initial trip with his sample case, and will reach the Pacific slope before starting to return.

Henry F. Barrows, head of H. F. Barrows & Co., who has removed his household to New York for the Winter, returned last week and spent a few days at the home of his son, Henry, in North Attleboro. The latter has been confined to his home by illness and was missed from the office.

Alpin Chisholm, of the Bugbee, Niles Co., left Monday for the west with his sample line. The great body of traveling men from the houses of the Attleboros will depart early in 1900. Maxy W. Potter, of J. M. Fisher & Co., is about the first of all to get away. He started last

week, and has reported great success already in New York, Chicago, Minneapolis and St. Paul.

Among buyers in town last week who called on the trade were: representative of Wiener Bros., New York; representative of Pfaelzer Bros. & Co., Philadelphia; W. S. and Dana Buxton, Springfield, Mass.; representative of Lehman & Prissman, Baltimore; I. Grohs, Indianapolis Jewelry Co.; Harris & Gips, Albany, and A. Ziehme, Chicago. A number of others, including Sol Cerf and M. Bonn, Pittsburgh, are due this week.

### Pittsburgh.

#### TRADE CONDITIONS.

Dec. 22.—A Christmas boom in on which is amazing and delighting all trades people. The stores are packed, and while many announce the closing hour as 10 o'clock, it is nearer midnight when customers can be prevailed upon to depart. The weary clerks are kept until two in the morning getting orders ready. There is not a single jewelry store in the two cities that is not reaping a harvest. The great number of cash sales is unprecedented, showing that people have the money and are paying. While the cheaper silver novelties have been utterly sold out, the amount of high-priced goods sold is extraordinary. The stiff prices of diamonds have had little or no effect upon the Pittsburgh buyer who wants diamonds this year. The receipts generally of this year's sales already surpass those of the year 1898. The numerous merchants in the city who do an office business have all told THE CIRCULAR representative that they are experiencing the trade of their lives.

The window displays this season do not show any uncommon ingenuity on the part of window dressers, with the exception of L. W. Vilsack & Co., who have unquestionably the most beautiful windows in the city. Their care and taste are rewarded by the admiration of all passers-by.

J. Brody, Fifth Ave., is selling out his stock.

Benjamin Lewis, the defaulting cashier of Grafner Bros., pleaded guilty to having taken \$350 in money, \$500 worth of checks, and \$1,000 worth of jewelry. He was to be sentenced on Saturday, Dec. 23.

Pittsburgh jewelry crime annals are further enhanced by the conviction, pending a sentence, of Samuel Horowitz, who was accused of buying a gold chain from Herman Elsholtz, who stole it from his employer, J. H. Link, a jeweler, 128 Chestnut St., Allegheny. The trio are an ornament to the small trade of the city, as Link has been convicted of selling liquor illegally. This is Horowitz's third offence and Elsholtz has a past record.

Requisition papers were applied for by Roger O'Mara, superintendent of the Bureau of Detectives, to bring Charles Hoyt, alleged to have been associated with James Reilly in the recent theft of a tray of diamonds from the store of A. E. Siedle, 507 Market St. Reilly has confessed that Hoyt is one of his accomplices. Hoyt's aliases are Baker and Harris. He was arrested by a Boston police official, who recognized his picture, which has been published in many papers, including THE CIRCULAR.

**Preservative Varnish for Metals.**—Coal tar, 3 parts; sulphur, 2 parts; red lead,  $\frac{1}{2}$  part. Dissolve all in carbonic sulphide and close up hermetically so as to prevent the sulphide from evaporating. Use as soon as possible in a cool place. Another composition:—Coal tar, 5 parts; chalk, 1 part; sulphur,  $\frac{1}{4}$  part. Boil in an iron vessel.

# The Jewelers' Circular

AND  
HOROLOGICAL REVIEW.

PUBLISHED EVERY WEDNESDAY BY  
**THE JEWELERS' CIRCULAR PUB'G CO.,**  
CORBIN BUILDING, 11 JOHN ST., COR. BROADWAY,  
NEW YORK.

TELEPHONE: CABLE ADDRESS:  
1148 CORTLANDT. JEWLAR, NEW YORK.

A JOURNAL DEVOTED TO THE INTERESTS OF JEWELERS,  
WATCHMAKERS, SILVERSMITHS, ELECTRO-PLATE MANU-  
FACTURERS, AND ALL ENGAGED IN KINDRED BRANCHES OF  
INDUSTRY.

Member of the American Trade Press Association.

Our editorial columns will contain our own opinions only, and we shall present in other columns only what we consider of interest or value to our readers. Advertising matter will not be printed as news.

Advertising rates in THE CIRCULAR are lower, considering the number of tradesmen reached by its large circulation, than in any other jewelry journal.

Notices of changes in standing advertisements must be received one week in advance; new matter can be received up to Monday.

### INFORMATION FOR SUBSCRIBERS.

#### Terms of Subscription, Postage Prepaid.

United States and Canada, - - -	PER ANNUM.	\$2.00
Foreign Countries in Postal Union, - - -		4.00
Single Copies, - - -		.10

New Subscribers can commence at any time.

Payments for THE CIRCULAR, when sent by mail, should be made in a Post-Office Money Order, Bank Check or Draft, or an Express Money Order or Registered Letter. All postmasters are required to register letters whenever requested to do so.

Pay money only to authorized collectors having proper credentials.

**Returning Copies.** Returning your paper will not enable us to discontinue it, as we cannot find your name on our books unless your address is given.

**Changing Address.** In changing address always give the old as well as the new one. Your name cannot be found on our books unless this is done.

**Discontinuances.** We will continue to send papers until there is a specific order to stop, in connection with which all arrearages must be paid; but such an order can be given at any time, to take effect at or after the expiration of the subscription. All such orders will be promptly acknowledged by mail.

**Liability.** The courts have decided that all subscribers to journals are responsible until arrearages are paid in full and an order to discontinue has been received by the publisher.

#### THE JEWELERS' CIRCULAR IN EUROPE.

Among the places in Europe where THE JEWELERS' CIRCULAR is on file are the following:

- LONDON—First Ave. Hotel, Holborn, E. C.; Holborn Viaduct Hotel, Royal Hotel.
- PARIS—Hotel de L'Athene, Rue Scribe.
- LEIPZIG—Handels-Zeitung, für die gesamte Uhren-Industrie.
- BERLIN—Deutsche Uhrmacher Zeitung, Jager-Strasse, 73.
- GENEVA—Journal Suisse D'Horlogerie.
- AMSTERDAM—Continental Club, Hotel Amstel.
- ANTWERP—Diamond Club, Rue de Pelican.

Vol. XXXIX. Dec. 27, 1899. No. 22.

Every line of reading matter in THE JEWELERS' CIRCULAR, with the exception of the few brief extracts from exchanges, always properly credited, is written exclusively for this journal. Each issue of THE JEWELERS' CIRCULAR is copyrighted. Permission to quote is extended to other publications provided such quotations are properly credited.

### Jewelers' Views on FROM an ocular standpoint

Watch Case Guarantees.

there is a sameness to the series of letters from retail jewelers regarding the guarantees on gold filled watch cases, as they are appearing from week to week in these pages; but as a matter of fact there is a great diversity of opinion and argument in the letters themselves. Many of these letters are written by the most firmly established jewelers in the trade, jewelers who have occupied honored places in the trade for a quarter of a century and over, jewelers who form the backbone of the industry; and they have entered upon the discussion with a degree of interest the like of which nothing has aroused for many a year past. They feel that the question involves more than the small immediate profits as represented by a few sales; it involves their reputation as honest, trustworthy merchants, an asset that once lost can never be regained. Therefore their arguments are often couched in spirited terms, but the logic of their contention is soundly based upon the premises. Taken all in all these letters are remarkably interesting reading, and while the discussion may, to those of rapid movement, appear prolix, it is fully warranted by the importance of the subject in its intimate relations to the everyday life of the jeweler's business. We here reiterate that all those jewelers who did not receive the letter of questions bearing on the subject, as printed elsewhere in this issue, are cordially invited to send their views, replying to the questions seriatim or collectively. Their replies will receive the same measure of consideration as those received direct from the letters themselves. We earnestly desire this, for the more views on this subject expressed by the trade at large the more convincing will be the conclusions reached.

SO soon as a decided curtailment of output of any species of article of value become widely believed through extensive newspaper publicity, do there arise wonderful schemes of production. This is notably true where diamonds are concerned. Now that the principal South African diamond mines are in jeopardy, owing to the beleaguerment of the city of Kimberley, reports of the finding of new and rich diamond fields are of frequent recurrence. The latest comes from Ontario, Canada, and says that "the northern shore of Lake Superior gives promise of a big discovery of diamonds in the near future, as deposits of slate and carbon resemble the deposits surrounding the diamonds of Kimberley. It is stated that several diamonds had been discovered in Wisconsin in exactly the same formations as existed in the Thunder Bay district of Ontario." Persons identified with institutions whose purpose is to minimize the profits of the smooth and persuasive operator of enterprises of large promise and small or no performance say that the most easily workable game to-day is that in which the "gold brick" is the principal article of commerce. This article is being sold in such large quantities that it can be bought at very low list prices with large discounts.

ACCORDING to the report under date of Oct. 28, 1899, of J. G. Stowe, United States Consul-General at Cape Town, South Africa, the exports of diamonds from Cape Colony for the nine months ended Sept. 30, 1898 and 1899, were as follows:

Nine months of 1898.	Nine months of 1899.
\$17,080,762.89.	\$18,525,057.89.

In view of the precarious situation of Kimberley and its mines at this writing, it would be interesting to know what will be the figures for the nine months ended Sept. 30, 1900.

### Letters to the Editor.

#### THE EMPLOYEES AT THE AFRICAN DIAMOND MINES.

LONDON, Eng., Dec. 5.

Editor of THE JEWELERS' CIRCULAR:  
In your interesting article (Nov. 15) on the Kimberley mines a misapprehension is apparent as to the native workers. A tenth of these are actual convicts supplied by the Government, the rest are free natives confined in compounds for the term of their individual contracts. According to the last return 1,819 whites and 11,211 natives were employed, and of the latter 1,055 were convicts. These figures comprise the DeBeers, Kimberley and Premier mines. F. R.

### Precious Metals in the Arts,

[The Sun.]

IT is easy to ascertain how much gold and silver are absorbed in the coinage of the various nations, but the most careful estimates as to the quantities of these metals used in the arts and industries are only approximate. Statisticians in the Treasury Department of the French Government recently undertook the considerable task of compiling the best information on this subject, and the figures they have reached are probably as accurate as any that have yet been published.

Most of the gold used in the arts is for ornamentation, though it is also employed to a large extent for the most practical purposes, as in dentistry. It is doubtful if even jewelry consumes a larger quantity of gold than some other ways in which it is used. The consumption for gilding alone is very large. The films of gold leaf are very thin, but enormous numbers of them are applied to a considerable variety of manufactures, such as signs, jewelry, books, frames, furniture, pottery and other articles, and the aggregate value of the gold thus used is very large. The consumption of gold for gilding has considerably increased since electro-gilding came into vogue, both because more gilding is done and also because the new process wastes a considerable quantity of the metal. According to the French figures the United States consumes in the arts about 31,000 pounds of gold in a year, which amounts in value to \$10,000,000 in round numbers. France, however, with her preëminent manufactures of jewelry and other articles of luxury, heads the list with an annual consumption of about 35,200 pounds a year. Great Britain also surpasses the United States with 34,100

pounds. Germany consumes 29,040 pounds. Switzerland 18,900, Italy 11,000, Russia 9,000, Austria-Hungary 6,175 and Belgium and Holland 6,820.

Perhaps one reason why the United States consumes in the arts a good deal more silver than any other country is because photography here, with its amateur branch, is far more extensively in use than in any other land. The chief industrial uses of silver are for solid silver plate and silver plating, mountings for harnesses and other ornamentation, and photography. The silver industries in the United States consume over 555,000 pounds a year. Germany and France about 330,000 pounds each, Russia 209,000 and Great Britain 208,000.

**Canada Notes.**

J. Silver, of J. & B. C. Silver, Montreal and New York, spent the Xmas holidays in Montreal, returning from New York for that purpose.

The will of the late Charles Potter, optician, Toronto, has been offered for probate. His estate is valued at \$58,277, left to his widow and family, with a few minor bequests.

Among the travelers covering the Montreal ground for the holiday trade last week were: Walter J. Barr, Goldsmiths Stock Co.; Jacob Levy, Levy Bros. Co., Hamilton, and Mr. Dyke, P. W. Ellis & Co.

W. K. McNaught, of the American Watch Case Co., Toronto, presided at a

banquet held by the National Club, on the 20th inst., attended by a number of leading public men, and made a stirring, patriotic speech in proposing the toast of the evening, "Canada and the Empire," in favor of joining Britain against the Transvaal.

A real estate transaction has just been completed whereby S. Frenkel, wholesale jeweler, who has been in the Canadian Express Co. building, Toronto, for a quarter of a century, has taken over the big warehouse at 53 Yonge St. The building has been leased for a long period, and the lessee has let contracts for the construction of a large vault and other improvements necessary for the business. The transaction indicates the improvement that has taken place in all lines of business, and especially the jewelry line.

Many out-of-town retail jewelers paid a visit to Montreal during the past two weeks for the purpose of replenishing their stocks for the holiday trade. The list included the following: W. H. Backus, Granby, P. Q.; L. Dupuy, Sherbrooke, P. Q.; D. Cantire, Quebec; J. E. Lachapelle, Joliette, P. Q.; Armand Cartier, St. Jerome, P. Q.; C. St. Jean, Louiseville, P. Q.; A. Nadeau, Shelford Mines, P. Q.; H. Girouard, St. Barnabe, P. Q.; A. Couture, Hull, P. Q.; A. Shetaudeau, St. Henri, P. Q.; J. E. Renie, Nicolet, P. Q.; J. O. Valiers, Shelford Mines, P. Q., and J. A. Baireteau, St. Remi, P. Q.

H. B. Meyers, Medford, Ore., announces he will open a jewelry store in the Crater building.

**Tariff Decisions & Regulations.**

**WEIGHING ONYX.**

WASHINGTON, D. C., Dec. 20.—With a view of securing uniformity of practice, the Treasury Department has instructed the various collectors of customs to weigh future importations of Mexican onyx in blocks or lumps too small and irregular for measurement in accordance with articles 1114 and 1115 of the customs regulations of 1892, and to determine the dutiable quantity on the basis of 180 pounds to the cubic foot, with allowance of 20 per cent for irregularities and waste. These instructions are in harmony with commercial usage at New York.

Among the decisions handed down last week by the Board of Classification of the United States General Appraisers were the following:

**CORAL BEADS.**

The protest of Ferd Holtz against the assessment of 60 per cent duty on coral beads was sustained. The beads were of graduated sizes, suitable for necklaces but were not strung. They were assessed as unfinished jewelry, but the importer claimed they were dutiable at 35 per cent as beads not strung. The Board find the 35 per cent clause more specific than the coral or jewelry clauses and sustain the protest.

**COQUILL GLASSES.**

Albert Berger & Co.'s protest against a 45 per cent duty on so-called "coquill glasses" was overruled. They claimed the goods to be entitled to free entry under paragraph 565 of the present tariff law. The Collector's assessment on these and on glass lenses imported by the same firm is sustained.

**CLOCK CASES.**

The protest of the Mermod & Jaccard Jewelry Co., St. Louis, against the assessment of 60 per cent on clock cases is overruled. The part of these pieces in which the works were to be enclosed was composed of earthen ware and invoiced as "majolica." The importers claimed that the goods were dutiable at 40 per cent under paragraph 191 of the present tariff law, but the Board decide they do not come within the purview of this paragraph. The Surveyor's classification under paragraph 95 is sustained.

**MODELS OF EYES.**

The protest of F. A. Hardy & Co., Chicago, was also overruled. The merchandise here consisted of models of the eye which were assessed at 60 per cent as manufactures of glass. The importers contended that the duty should be 35 per cent under paragraph 450, as manufactures of papier mache, but the Board find this claim to be unsupported. The Collector's decision is affirmed.

**Death of F. E. Treibs.**

F. E. Treibs, the founder and senior partner of the firm of F. E. Treibs, Oberstein, Germany, and of Treibs Bros., 68 Nassau St., New York, died on Dec. 26, at the age of nearly 80 years.

**WIRE US**

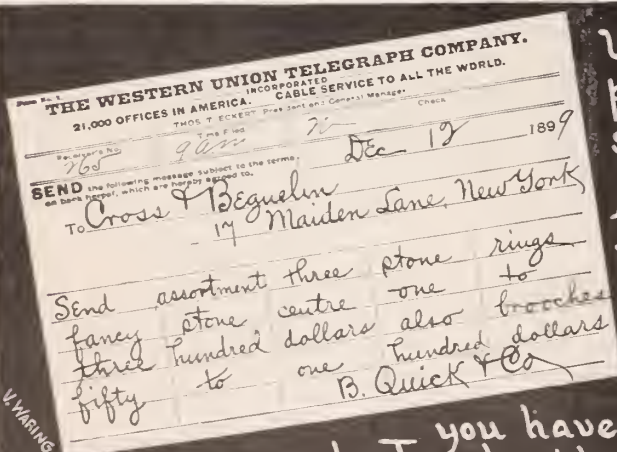

We are prepared for just such orders as this, and fill them soon as received.

If you have special calls for anything

you haven't got in Diamond Jewelry telegraph or telephone just what you want, and you'll get it by return express! Our very complete stock of Mounted Goods is at your service.

**CROSS & BEGUELIN**

Importers and Cutters of Diamonds and Precious Stones

43 Rue de Mestay, PARIS

Telephone, 2188 Cortlandt

17 Maiden Lane, NEW YORK



**New York Notes.**

A judgment for \$105.13 against Jacob Silverstein has been entered by M. Kollender.

The annual meeting of the stockholders of A. Steinhardt & Bro. will be held at the office of the company, 452 Broadway, Jan. 9, 1900, at 2 o'clock P. M.

An order was granted in the City Court, Thursday, appointing Thos. F. Coen receiver for Angela M. Devlin, in supplementary proceedings instituted by the Bartens & Rice Co., judgment creditors.

Jas. P. Silo, auctioneer, 43 Liberty St., last week conducted a sale of jewelry and watches by order of the attorney for some firms to whom the goods had been assigned some years before. The sale took place from Tuesday until Saturday and included over 1,000 pieces.

Judge Townsend, in the United States Circuit Court, Thursday, handed down a decree reversing the decision of the Board of General Appraisers, upon the protest of A. Steinhardt & Bro. The merchandise involved in the protest was pins and lace pins, which the Judge finds should have been properly assessed for duty at 30 per cent, under paragraph 206 of the Tariff act of 1890.

The three suits in the City Court, brought by the Spencer Optical Mfg. Co., L. & J. Adler and Adolph Goldsmith & Son against Jos. Bachrach, have been settled out of court. The actions were for goods sold and delivered and were commenced about eight years ago, after Bachrach's failure. Orders discontinuing the actions without cost were signed before Judge Schuchmann, Thursday.

Wm. C. Stuckel was arraigned before Magistrate Mott, of the Yorkville Police Court, Thursday, and held in \$2,000 bail on a charge of larceny. It is alleged that the prisoner, on Labor Day, 1898, stole several gold watches from a jewelry show case at Third Ave. and 59th St. The detectives who arrested him claim that he admitted the theft while serving a term in the penitentiary for another crime.

The jewelers' trust and safe deposit companies, the former to be known as the Sterling Trust Co., will probably be organized within a very short time. A meeting of some of the parties interested in the movement to start these companies was held last week, but a regular meeting for the purpose of organizing, a CIRCULAR reporter was told, Thursday, would be held at an early date. It is expected there will be about 22 or 23 directors in the trust

company, about half of them gentlemen representing the jewelry trade and the other half well known capitalists of this city.

Eaton & Glover, makers of the Eaton-Engle engraving machine, 87 Nassau St., have incorporated their business under the style of the Eaton & Glover Co., with a capital of \$75,000. W. S. Eaton is the president of the concern, W. T. Goodnow the vice-president, and Frank B. Glover the secretary and treasurer. In giving the reasons for the incorporation the firm state that during the past three years their business has grown to such an extent that it had become too large and unwieldy to be conducted by a partnership.

A colored man named James Reid was arraigned in the Grant St. Court, Brooklyn, last week, charged with burglary. Reid at first refused to say where he had obtained certain silver ware found in his possession, but afterwards said it was stolen from a Myrtle Ave. jewelry store. He said he went there with two other men, who broke open the rear door and then gave him the silver ware and jewelry to take care of. Reid pleaded guilty to the charge of burglary before Magistrate Steers, but said there were others in the case. He was held for the action of the Grand Jury in \$500 bail.

There is a controversy at the present time over the ownership of a painting by George Inness entitled "Sunset," which is now in the possession of Thos. Kirkpatrick, retail jeweler, 33d St. and Fifth Ave.

The picture is claimed by a Mr. Miller, of Montclair, N. J., who says that it is worth \$2,000, but that he bought it three years ago for \$900. Mr. Miller claims that the picture was obtained from him on a pretence that it was to be shown to a customer, but was pawned instead. He has had Wm. Wild and Richard Oppenheimer indicted on this charge. Jeweler Kirkpatrick purchased the picture for \$250 and by the advice of his counsel is holding it until Mr. Miller substantiates his claim or pays him the money advanced upon it.

There is on foot at the present time a movement to establish an athletic club among the jewelers and employes of jewelers in the vicinity of Maiden Lane, and it is expected that the movement will take definite shape shortly after the first of next year. It is the intention of those organizing this club to form a first class athletic association that will be equal, if not the superior, of any association of its kind in which the membership is limited to people of a particular trade. It is contemplated not only to have gymnasium athletics, but also to organize bowling, football and other teams and bring into it those members of the trade who are interested in any sports of this kind. Effort is now being made to arrange for suitable headquarters in Maiden Lane, and when these are secured it is expected that the full quota of membership will be obtained in a short time. Among those interested in the movement, and to whom persons wishing to join this club should communicate, are

**C. Dorflinger & Sons,**

36 MURRAY STREET,

NEW YORK,

MANUFACTURERS OF

**FINE GLASSWARE,**

desire to establish an agency in Chicago with control of middle west, in connection with some representative house in a kindred line.

1851.

1899.

**THE CHATHAM NATIONAL BANK, NEW YORK.**

CAPITAL STOCK, - - - \$450,000

UNDIVIDED PROFITS, - - - 974,518

GEO. M. HARD, President.

H. P. DOREMUS, Cashier.

W. H. STRAWN, Ass't Cashier.

M. Maniste, with Greenberg & Glaser, 71 Nassau St., and M. Foster, with Stern Bros. & Co., 68 Nassau St.

O. K. Treibs, of the firm of Treibs Bros., 68 Nassau St., returned from Europe on Dec. 23, on the *St. Paul*.

Ernest Block left the employ of W. & S. Blackinton Dec. 1 and joined Louis Stern & Co., formerly Young & Stern. He succeeds Louis Stern in the western territory and is said to have a small interest in the concern.

Louis Witsenhausen, 37 Maiden Lane, and Miss Rose Ballin, of this city, will be married on Jan. 16, at Sherry's, Fifth Ave. and 44th St. Invitations to the wedding have been sent out by Mr. and Mrs. Ballin, 201 W. 117th St., the parents of the bride.

A large crowd collected in front of 63 Nassau St. Friday morning and stopped to scan the sidewalk in the belief that a diamond had been lost from the window of one of the offices above. This proved untrue, as the only thing lost was a second hand of a watch, which had dropped from the window of the office of Geo. Schmid, watchmaker, on the third floor. The crowd soon realized their error and dispersed.

A new firm will be started at Antwerp, Belgium, by the first of February, 1900, that will make a specialty of cutting diamonds for the American market and especially of *melée*. The concern will be known as Vrieslander & Morells, and will consist of H. S. Vrieslander, Leondard Vrieslander and Jno. Morells, all well known to the New York diamond trade. H. S. Vrieslander has been in the diamond business from his early boyhood and has been in this country for the past 10 years. He is well known as a cleaver for several large diamond cutting firms. Leondard Vrieslander is a brother of H. S. Vrieslander, and the third partner, John Morells, is now connected with the cutting department of L. & M. Kahn & Co. Messrs. Vrieslander and Morells will leave this country for Europe Jan. 3 on the Red Star liner *Kensington* and expect to establish their factory and have it in working order by February.

There was considerable commotion in Maiden Lane on the evening of Dec. 19, due to the loss of a package containing a diamond ring valued at \$334.80 which was about to be shipped by S. F. Myers Co., 50 Maiden Lane, to one of their customers. The package, with a quantity of others, had been given in charge of two messengers of the house, Saml. Abrahams and Henry Hansel, and were taken by them to the express agent. When the packages

were checked off by the agent it was found that the small one containing the ring in question was missing and a search was then commenced in which hundreds of passers-by joined. The search, however, proved fruitless. The following day a young man who gave his name as W. H. Thurber and who stated that he resided in Paterson, N. J., called at the office of S. F. Myers Co., and after some negotiations returned the missing package. He said that he had stepped on it in walking through Nassau St., and opening it discovered the ring. He received from Mr. Myers a reward of \$100.

On the charge of stealing jewelry from express packages in transit, John Stead, who is employed as a clerk at the eastern office of the Adams Express Co., 49th St., near Fourth Ave., was held Saturday in \$2,000 bail in the Centre St. Police Court. Stead was caught by his employers, Friday, in the act of stealing a necklace containing 62 diamonds from a package which was to have been sent to Rochester. The express company had recently lost several valuable packages entrusted to their care, and set on foot an investigation, which showed that suspicion pointed to Stead, and a watch upon him resulted in his detection and arrest. When arraigned in the Centre St. Police Court, Stead gave his address as 593 Ninth Ave. and was held to await the action of the Grand Jury in the above mentioned bail. The name of the consignor of the package as well as the value of the necklace and any further details of the robbery could not be obtained from the office of the Adams Express Co.

**Trade Gossip.**

Among the first calendars for 1900 to be presented to the trade is that issued by L. Heller & Son, diamond importers, 48 Maiden Lane, New York. This calendar contains features out of the ordinary that make it especially desirable as a souvenir. The monthly calendar in large bold type is mounted on a hanger showing at the top a large, fine half-tone engraving of the Dewey arch at Madison Square, New York.

The new line of guard chains, suitable as lorgnette, watch, fan, muff, purse or eyeglass chains, that B. A. Ballou & Co., Providence, R. I., are now showing, merits the attention of the trade. The line, which is very large and complete, contains many new patterns of chains and slides, and the present tendency toward heavier chains has been considered by the manufacturers, who have some patterns which they believe cannot be duplicated elsewhere.

**INDEX TO ADVERTISEMENTS.**

Aikin, Lambert & Co.....	2
Aikin, Lambert Jewelry Co.....	2
American Watch Case Co.....	47
American Waltham Watch Co.....	19
Arnstein Bros. & Co.....	48
Austin, John, & Son.....	48
Avery & Brown.....	12
Ball, Wm. H., & Co.....	9
Ballou, B. A., & Co.....	21
Bassett Jewelry Co.....	2
Bell Watch Case Co.....	18
Billings, Chester, & Son.....	9
Borgzinner, S. & A.....	39
Bowden, J. B., & Co.....	8
Bradley Polytechnic Institute.....	48
Bradley & Hubbard Co.....	44
Burroughs, P. J.....	36
Chatham National Bank.....	29
Clark & Coombs.....	44
Clyde Line.....	42
Conley & Straight.....	48
Cook, Edward N.....	47
Cross & Bequelin.....	28
Crossman, Charles S., & Co.....	12
Crouch & Fitzgerald.....	47
Crown and Lion Watch Cases.....	46
Day, Clark & Co.....	48
Deitsch Bros.....	44
Dorflinger, C., & Sons.....	29
Dubois Watch Case Co.....	47
Dueber-Hampden Co.....	15
Eisenmann Bros.....	10
Eliassof Bros. & Co.....	42
Esser & Barry.....	44
Fahys, Jos., & Co.....	38
Fairchild & Johnson Co.....	48
Field & Beattie.....	44
Foster, Theodore W., & Bro. Co.....	2
Frankel's Sons, Jos.....	12
Friedlander, R., L. & M.....	48
Fuchs, Ferd., & Bros.....	44
Goodfriend Bros.....	9
Hamilton & Hamilton, Jr.....	11
Hancock, Becker & Co.....	33
Harris & Harrington.....	48
Hedges, Wm. S., & Co.....	8
Heimberger & Lind.....	47
Hraba, Louis W.....	2
Jacot & Son.....	44
Juergensen, Jules.....	8
Kahn, L. & M., & Co.....	48
Knowles, Dr.....	44
Knowles, J. B. & S. M., Co.....	7
Kohn, Alois, & Co.....	44
Lady Racine.....	42
Lederer, S. & B., Cp.....	48
Ledos Mfg. Co.....	47
Levy, L. W., & Co.....	48
Lind, Thomas W.....	4
Lintz, Jules J.....	40
Malliet, C. G., & Co.....	8
Mathews & Prior.....	10
Mathey Bros., Mathez & Co.....	33
Mauran, John T., Mfg. Co.....	35
Mauser Mfg. Co.....	33
Mercantile National Bank.....	20
Mossberg & Granville Mfg. Co.....	16
Mount & Woodhull.....	8
Myers, S. F., Co.....	40
New England Watch Co.....	17
Nissen, Ludwig, & Co.....	24, 25
Omega Watches.....	4
Oppenheimer Bros. & Veith.....	9
Pairpoint Mfg. Co.....	44
Potter, Wm. K.....	40
Providence Stock Co.....	48
Remington Typewriters.....	47
Reichhelm, E. P., & Co.....	48
Reisner, L. C., & Co.....	3
Rich, H. M., & Co.....	44
Robert, E. E.....	16
Roy Watch Case Co.....	37
Rumpp, C. F., & Sons.....	46
Saunders, John F.....	9
Schulz & Rudolph.....	8
Sherwood, John W., & Co.....	14
Simmons, R. F., & Co.....	6
Simmons & Paye.....	44
Simons, Bro. & Co.....	47
Smith, Alfred H., & Co.....	10
Stern Bros. & Co.....	33
Sternau, S., & Co.....	17
Street, Geo. O., & Sons.....	33
Towle Mfg. Co.....	36
Treibs Bros.....	12
Valfer, S., & Co.....	30
Wallace, R., & Sons Mfg. Co.....	6
Westphal, W. C. A.....	46
Wheeler, Hayden W., & Co.....	13
Whiting, F. M., & Co.....	32
Wood, Chas. F., & Co.....	48
Wood & Hughes.....	44
Woods & Chatellier.....	16

**Something New in Travelers' Watch and Ring Trays.**

THE STRONGEST TRAY EVER MADE.  
GUARANTEED NOT TO BREAK FOR A YEAR.

See next issue of THE JEWELERS' CIRCULAR for full information.

**S. VALFER & CO., = 33 Maiden Lane, New York.**

## Special Notices.

Rates 75c. per insertion for notices not exceeding 3 lines (25 words); additional words 2 cents each. If answers are to be forwarded, postage stamps must be enclosed. Two insertions, 15 per cent off; three insertions, 20 per cent off; four insertions or more, 25 per cent off. Payable strictly in advance.

Display cards on this page will be charged at \$2.00 per inch for first insertion, subject to same discount as above for subsequent insertions.

Under the heading of **SITUATIONS WANTED** on this page advertisements will be inserted for **One Cent a Word**, each insertion, no discount, but no advertisement will be inserted for less than 25 cents. This offer refers to **SITUATIONS WANTED ONLY**. Payable strictly in advance.

In all cases if answers are to be forwarded, 10 cents extra to cover postage must be enclosed.

## Situations Wanted.

**PRACTICAL DESIGNER**, with 15 years' experience in all branches of sterling silver ware, desires position; all references furnished. Address "Sterling," care Jewelers' Circular.

**YOUNG MAN** with large established retail trade wishes to obtain a manufacturer's 10k. or 14k. line Jan. 1, 1900. "O. K.," care Jewelers' Circular.

**TRAVELING SALESMAN**, plated ware line, desires position Jan. 1, with first-class house; experience and all references. Address, F. P., care Jewelers' Circular.

**SUPERINTENDENT AND DESIGNER** with large experience in all branches of sterling silver ware desires position; best of references. Address "Designer," care Jewelers' Circular.

**SITUATION** by fine watchmaker, engraver, competent on all fine American and Swiss watches, 18 years' experience, good salesman; can mount diamonds; fine references; salary, \$20 per week. James J. Leonard, Cairo, Ill.

**EXPERIENCED TRAVELING SALESMAN**, 10 years on the road and acquainted with the best trade in the west and middle western States, is open for engagement Jan. 1 to 15; best of references. Address, D. G., care Jewelers' Circular.

**FINE WATCHMAKER** and engraver, good diamond setter, competent on chronographs and repeaters; 20 years at the bench, sober and good salesman; fine references; \$20 per week; will come at once. Charles J. Watts, Cairo, Ill.

**SITUATION** by fine watchmaker, engraver, competent on chronographs and repeaters, sober and reliable, 20 years' experience, good references, good diamond moulder and good salesman; salary, \$22 per week. Chas. J. Smithson, Memphis, Tenn.

**EXPERIENCED TRAVELER** desires position from Jan. 1; well acquainted with the retail trade east and west; understands diamonds, colored goods, loose or mounted; watches, jewelry or silver ware; best of references. Address A. J., care Jewelers' Circular.

**EXPERIENCED SALESMAN** with established trade for New York City and State, Philadelphia, Baltimore, Washington and Pennsylvania, desires position Jan. 1; 20 years with present firm; highest reference; ring manufacturer preferred. Address L. E. W., care Jewelers' Circular.

**AN OPTICIAN**, watchmaker and engraver wants a steady position with a good firm; understands the business thoroughly; young man, single, sober and steady; have tools and trial case; state salary in first letter; all references. Address "Optician," care Jewelers' Circular.

**TWO FIRST-CLASS SALESMEN** with office on Maiden Lane desire to represent in New York and vicinity a first-class silver ware or jewelry manufacturer; have an established trade with jewelers, silversmiths and department stores and can handle a good line on commission basis. Address, "Hustlers," care Jewelers' Circular.

**WANTED**—Situation by watchmaker, engraver and salesman; American, 38 years old, 26 years' experience at bench, five years with present employer; fully competent to take entire charge of store or department; if you want sober and industrious man, write me; personal reasons for desiring change. Address "Blue 19," care Jewelers' Circular.

## Help Wanted.

**WANTED**—A traveler acquainted with gold pen trade. Address with particulars, Box 1155, New York City.

**A GOOD MODELER** and designer for sterling silver hollow ware; city; steady job for the right party. Address, S. J., care Jewelers' Circular.

**AN EXPERIENCED TRAVELER** for the middle West to carry a line of diamonds and watches. Address with full particulars, R. A., care Jewelers' Circular.

**YOUNG MAN** who has had experience in the jewelry box business as inside salesman and make himself generally useful. Address, A. G., care Jewelers' Circular.

**WATCHMAKER AND ENGRAVER**—Permanent position to a good all-round man; splendid climate. Address at once, Prentice Luckey, Spartanburg, S. C.

**WANTED**—A first-class traveling man to represent me in the nearby states; one with experience necessary; good opening for a "hustler." L. W. Rubenstein, 54 Maiden Lane, New York.

**WANTED**—Two first-class manufacturing jewelers and stone setters; one first-class engraver and jeweler; references required. Geo. Wettstein, manufacturing jeweler, Cedar Rapids, Iowa.

**PLATED WARE SALESMAN** wanted to sell a high-grade line on commission as a side line; only those having at least three years' acquaintance with the jewelry trade need apply. Address, "Flatware," care Jewelers' Circular.

**JEWELRY TRAVELING SALESMEN** to carry a side line on commission of a new collar-button just being put on the market and extensively advertised; only those of high standing and controlling trade will be considered; mention territory now covering; references given and required. H. M. Mays, 235 Eddy St., Providence, R. I.

**AFTER JAN. 1**—A first-class manufacturing jeweler and stone setter who can make all kinds of diamond mountings, cluster work, and understands enameling and the use of dynamos for gilding and plating, as foreman in a newly equipped shop with six to eight men; highest salary and permanent position to right man; best of references required. Address G. O., care Jewelers' Circular.

## Business Opportunities.

**I BUY JEWELRY STOCKS**.—Retailers or wholesalers wishing to dispose of surplus or entire stock of diamonds, watches and jewelry can find quick cash buyer by addressing John Grosberg, 104 2d St., New York.

**WE DESIRE TO ACT** as New York representative for silver ware manufacturer; have established place of business near Union Square, and wish to communicate with some reliable house. V. M. C., care Jewelers' Circular.

**JEWELRY STOCKS BOUGHT**—Retailers wishing to dispose of surplus or entire stock of diamonds, watches and jewelry can find quick, cash, strictly confidential buyer by addressing S. Marx, 22 Lispenard St., New York City.

**\$500 WILL BUY** stock and fixtures of good paying jewelry and optical business in growing live town in South Jersey; this is a good chance for young man with small capital who is a good, all-round workman; present owner must go to Europe and would make sacrifice. Address, N. J., care Jewelers' Circular.

## For Sale.

**FOR SALE**—Large Mosler fire-proof jeweler's safe; weight, 5,600 lbs.; 6 feet high, 4 feet high inside. W. S. Parker, Prairie City, Ia.

**FOR SALE**—The Arundel trade-mark, copyrights and stock of lenses; party having other business requiring his attention. Address, "Arundel," Van Hiseville, Ocean Co., N. J.

## To Let.

**FRONT OFFICE**, 18x72 (occupied by the E. Howard Watch and Clock Co. for 14 years); also smaller offices and rooms for light manufacturing; rents low. Knapp Building, 41 and 43 Maiden Lane, New York.

**SALESMAN** to travel south wanted with an up-to-date line of medium price Solid Gold Jewelry (Diamond set, &c.), extensive line of Sterling Novelties and high-grade Gold-Filled Vest Chains, Lorgnette Chains, Dumb-bell Links and Brooches. Salary, \$2,000 and expenses. Don't answer this unless you have established trade south, and can furnish high-grade references.

Address with particulars, "WIDE AWAKE,"

Care of JEWELERS' CIRCULAR.

## TO LET

IN THE

**UPTOWN JEWELRY and SILVERWARE DISTRICT,**

UNION SQUARE, WEST,

From Feb. 1, for a term of years, No. 19, (second door above Tiffany's), large store, basement, first and second floors; separately if desired. Janitor on premises. Apply to

HORACE W. DAY,

17 STATE STREET, NEW YORK.

TELEPHONE, 724 BROAD.

## JUST RECEIVED.

**"Precious Stones  
...and Gems,**

**Their History, Sources  
and Characteristics,"** \*

By **EDWIN W. STREETER,**

London, England.

ILLUSTRATED WITH COLORED PLATES.

**SIXTH EDITION.**

Revised and largely re-written up to date.

**345 pp. Price, \$6.**

The contents of the volume may be briefly summarized as follows: Precious stones in general—Sources; history; working; cutting (including various forms); engraving and carving; burning and coloring; and trade conditions (50 pp.); diamonds (95 pp.); rubies (31 pp.); sapphires (14 pp.); star stones, spinel and bolog (5 pp.); emeralds (10 pp.); true cat's eye and Alexandrite (5 pp.); opals (5 pp.); turquoise (14 pp.); semi-precious stones, about 40 varieties (74 pp.). Classifications, appendices and index occupy the remaining 34 pages.

The Jewelers' Circular Publishing Co.,

11 JOHN STREET,

Corner Broadway, NEW YORK.

DON'T FORGET THE JEWELERS' CIRCULAR PUBLISHING CO.'S BOOK LIST when in want of any technical work in the Jewelry or Kindred Trades.

### News Gleanings.

Geo. D. VanHorn has opened a repair shop in Paris, Tenn.

Thos. F. Cahill has improved his store in Spencer, Ind.

Harold C. Ormsby will open a jewelry store in Skowhegan, Me.

Dwight Taylor has opened a jewelry store in Jewell City, Kan.

H. McCallum will open a watchmaker's shop in Biloxi, Miss.

J. H. Stephens has opened a new stock of jewelry in Heber, Utah.

The stock of J. H. Sykes, Paterson, N. J., is being sold at auction.

W. A. Townsend has discontinued his jewelry business in La Porte, Ia.

A judgment for \$22 has been rendered against Matt Valerius, Keota, Ia.

Judgment for \$71 has been rendered against L. L. Alnutt, Chillicothe, Mo.

Daniel L. Saul will start a silver plating establishment in South Bethlehem, Pa.

George S. Hollenbeck has re-engaged in the jewelry business at Chebanse, Ill.

W. A. Staats, Somerville, N. J., has removed to his new building in that town.

M. Beskow has moved his stock of jewelry, etc., from Whitewright to Detroit, Tex.

W. H. Chapman, Dodge City, Kan., has made a number of improvements to his store.

H. Cassell, of New York, has purchased the stock of B. F. Anderson, Parkersburg, W. Va.

Mrs. J. Braun, aged 77 years, wife of J.

Braun, jeweler, Reedsville, Wis., died Dec. 20, of paralysis.

W. E. Kennedy, Benton Harbor, Mich., contemplates opening a branch store in Eau Claire, Wis.

In a fire in Bear Lake, Mich., last week, N. E. Hull's jewelry store and residence were burned out.

Porter & Marlow, Moline, Kan., have given a warranty deed on real estate for a consideration of \$50.

In a fire in Laurel, Del., a few days ago, the residence and store of Benjamin Maloney, jeweler, were burned.

A fire from a defective flue caused \$300 damage at Nefflen's jewelry store, Lonaconing, Md., a few days ago.

Whitney & Varney opened their new jewelry store in Odd Fellows' block, Brunswick, Me., on Dec. 18.

W. G. Austin, Martinsburg, W. Va., has removed his jewelry store from 112 N. Queen St. to 128 N. Queen St.

J. M. Jenney, Weiser, Idaho, who recently sold out his drug store, has opened his jewelry stock in new quarters.

The Southern Loan & Jewelry Co., Tampa, Fla., have purchased the stock of T. E. Coggins, lately bankrupt, at St. Petersburg, Fla.

Robert M. Barnitz, York, Pa., who had been confined to the house for a week or more with an attack of quinsy, is out again.

Wm. L. Emerson, of Chicago, has taken the management of the jewelry department of T. A. Dougherty & Co.'s store, Stanberry, Mo.

F. B. Reed, having sold his jewelry store to A. F. Smith, Decorah, Ia., has become a traveling salesman for W. F. Main Co., Iowa City, Ia.

H. T. Coffin, of New Castle, Ind., has formed a partnership with Earl Woodbury, of Richmond, and the firm will hereafter be styled Coffin & Woodbury.

Burglars entered the jewelry store of Vance Robb, Jackson Center, O., on the night of Dec. 19, and attempted to blow open the safe, but were frightened away.

Frank Crocker, formerly with A. J. Wipperman, Rock Springs, Wyo., has opened a jewelry shop in Dr. J. W. Hauk's drug store, Green River, Wyo.

Charles B. Shuster died last week in Scranton, Pa. He was about 50 years old and formerly resided in Shamokin, Pa., where for a number of years he conducted a jewelry store.

Frank Conklin, for several years in charge of J. S. Hall's branch jewelry store in Summit, N. J., has purchased the jewelry business of the late Louis Mandlestam, Wulff building, that town.

Liniord Cut Glass Co., of Jamestown, N. Y., have incorporated with a capital of \$20,000. Directors: W. H. Linford, George H. Aherns, Henry W. Odell, Ralph C. Sheldon and C. B. Winsor, Jamestown.

I. O. Brown's jewelry store, Wheaton, Minn., was burglarized a few evenings ago and about \$75 worth of valuables carried away. L. H. Harvey has been arrested and bound over to await the action of the Grand Jury.

When C. J. Doerflinger, Brunswick, Ga.,

returned to his jewelry store a few evenings ago he found that one of his heavy plate glass windows had been broken and about \$20 worth of gold watch chains, left in the window, gone.

Lawrence Farrell was before the Commissioners of Appeal in Trenton, N. J., Dec. 18, in relation to \$5,000 exemption because of money owing the Trenton Watch Co. Officers of the company swore that he owed the money, and the exemption was allowed as claimed.

It was announced Dec. 7 that the jewelry firm of Mattox & Co., Walkertown, Ind., composed of M. R. Burger and Minnie Mattox, dissolved partnership Aug. 23, 1899, Mr. Burger selling his share to Minnie Mattox and withdrawing from the firm.

The top shelf of four in J. A. Stapf & Son's jewelry store show window, Dunkirk, N. Y., broke, one day last week, and the three underneath went down in succession. The shelves were of plate glass, were loaded with cut glass, and the window floor contained cut glass. The result was a general smash.

John Stabode, a jeweler of Mt. Carmel, Pa., has mysteriously disappeared. On Nov. 21 he left there carrying a kit of tools and a half dozen gold and silver watches. He told his friends he was going to Excelsior, Shenandoah and other places, but expected return within a week. He has not been seen since.

At 12.15 o'clock P. M., Dec. 15, a blaze occurred in the cellar of the three-story frame building on Washington St., Stoughton, Mass., belonging to H. W. Darling. The fire started in the cellar, supposedly from an overheated furnace, and made great progress. The lower floor was occupied by Mr. Darling's jewelry store.

A gasoline heater attached to a stove used by plumbers who were at work on the Vogt Optical Co.'s establishment, 146 N. Water St., Rochester, N. Y., exploded with considerable force a few days ago. Prompt action on the part of the plumbers and workmen in the employ of the company prevented a serious conflagration. The explosion blew out two windows in front and two in the back and set fire to some wood work.

The concession for the sale of optical goods at the Pan-American Exposition, at Buffalo, N. Y., has been let. Although the terms are kept quiet it is understood the concession will be divided between a New York and Chicago firm, each paying \$6,250 to the Exposition. The concession simply covers the sale of spectacles and eye glasses. In addition a Canadian firm will have the right to sell small microscopes, for which they will pay \$1,500.

The jewelry store of John Schaefer, 400 William St., Buffalo, N. Y., was broken into shortly before 2 o'clock A. M., Dec. 21. The burglars entered the place by breaking a window in the rear of the store and crawling in. While in the midst of their work they were discovered by a woman who lives overhead. She gave the alarm. The burglars seized 10 pairs of opera glasses and a dozen gold pens and made their escape. The police have a description of the men.

**STERLING  
SILVER  
GOODS ONLY**

TRADE  
MARK

STERLING

**FRANK N. WHITING & CO.**

**SILVERSMITHS**

**NORTH ATTLEBORO  
MASS**

1128 B'WAY, NEW YORK.  
220 SUTTER ST, SAN FRANCISCO.

**Lancaster, Pa.**

An interview with the local jewelers developed that this season has been the largest experienced in a number of years. This is particularly true of their watch trade.

For the first time in its history the Hamilton Watch Co. factory closed but one day, Christmas, at this season of the year. The increased business prevented a longer holiday.

George Houston, of Mechanicsburg, a graduate of the defunct Pendergast Horological Institute, this city, an engraver in the employ of Edwin Keller & Sons, Allentown, narrowly escaped death by asphyxiation on Wednesday last. The young man was found insensible in a room of the Grand Central hotel with the gas turned on. After hard work by physicians he was resuscitated. It was attributed to an accident.

Since the formation of the firm of J. M. Jenks & Co., Louis Sondheimer being the company, the establishment has done twice as much business as the firm's predecessor, the Zahm concern. "Jim" Jenks has been on the road in the jewelry business for 30 years and is one of the best known men on the road. He has established a large trade in the west and is continually increasing the same. The firm's specialty is secret society goods and they have been working nights since Nov. 1, the entire force of 30 people being employed. The firm have under consideration large additions to their plant.

L. C. Reisner & Co., as has been their practice since the inception of the house, remembered their employes on Christmas. The married men in their establishment, 14 in number, each received a turkey, the largest Mr. Reisner could procure. The single employes, of whom there is a large number, were each presented with a crisp dollar bill. The good fellowship existing between the house and the employes has frequently been cemented more firmly by just such acts of kindness. L. C. Reisner reports the largest holiday season in the history of the house. The factory was in operation until midnight for two weeks prior to Christmas.

**Worcester, Mass.**

W. A. England, in Central District Court, last Monday, charged with assaulting Nettie C. Ellis, was discharged after a hearing that lasted all day. "There is not the slightest evidence to show that there was an assault," said the Judge.

Dr. Lamson Allen, treasurer of the Worcester Optical Co., has resigned, and Hon. Francis A. Harrington has been elected his successor. Dr. Allen has a large practice and gives as the reason for his resignation that he could not give to the business the time it deserves.

E. H. Souder has opened a jewelry store at 59 S. Pearl St., Albany, N. Y.



**DESIGNS, QUALITY, PRICES,**  
**Small Profits and Large Sales**  
 combined have created the  
 great demand for the . . .  
**10k. and 14k. Gold Jewelry]**  
MANUFACTURED BY  
**HANCOCK, BECKER & CO.,**  
 Providence, R. I.  
**SOLD THROUGH JOBBERS ONLY.**

We have made a specialty of

**FINE FINGER RINGS**

for more than half a century.

**GEO. O. STREET & SONS,**

24 JOHN ST., NEW YORK.

... Established 1837 ...



These well-known Razors, the quality of which is warranted, possess this great advantage, that they may be used for ten years before they require actual sharpening. Before using them it is necessary to rub them on good leather strop. Le Coultre's Strops (to be had with the Razors) should be used in preference to others.

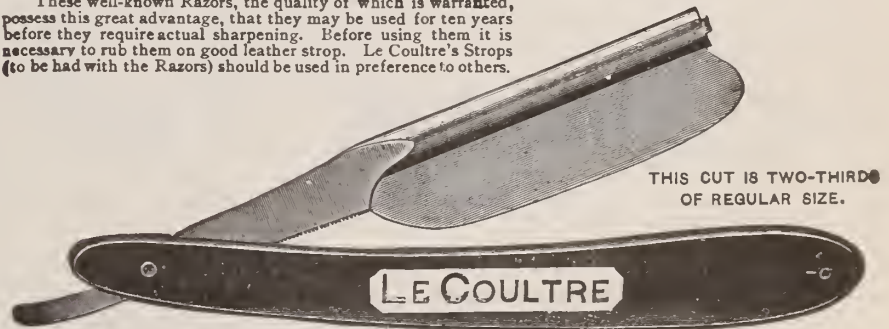

THIS CUT IS TWO-THIRDS OF REGULAR SIZE.

"SPECIAL"—Single Razors for Jewelers' Travelers at trade price.

**MATHEY BROS., MATHEZ & CO.**

Send for Price List.

Sole Agents, 21 & 23 MAIDEN LANE, N. Y.

**Stern Bros. & Co.,**

Cutters of . . .

MANUFACTURERS OF

**DIAMONDS, Gold Rings and Thimbles,**

68 NASSAU STREET, NEW YORK.

RING FACTORY, 33-43 GOLD STREET, NEW YORK.

LONDON OFFICE, 29 ELY PLACE.

DIAMOND-CUTTING WORKS, 142-146 W. 14TH ST., NEW YORK.

CHICAGO OFFICE, 149 STATE ST.



**THE MAUSER MFG. COMPANY,**  
 SILVERSMITHS,

"Watch Our Ads." 15th St., bet. Broadway and Fifth Ave., New York.

THE EMPIRE WESTWARD TAKES ITS WAY

# WESTERN SUPPLEMENT

## THE JEWELERS' CIRCULAR

VOL. XXXIX.

NEW YORK, WEDNESDAY, DECEMBER 27, 1899.

No. 22.

### Chicago Notes.

All communications in reference to the Chicago department of *The Jewelers' Circular*, addressed to Stephen Parlin, 1522 Lill Ave. (Telephone, Lake View 397), Chicago, will receive prompt attention.

Gus Rodenberg, the Chicago representative of S. & B. Lederer Co., is back from the east.

Louis Manheimer and family will shortly leave for New York on a few weeks' pleasure trip.

A. Weiss, Chicago agent for J. J. Cohn, leaves for New York Jan. 1 for a short business visit east.

Most of the men in Chicago with stocks of eastern factories left for home the Saturday before Christmas.

Fred H. Allen, representing Barstow & Williams here, leaves for the factory Jan. 10 for consultation regarding business for the coming season.

Ernest Block, late with W. & S. Blackinton and now a member of the firm of Stern & Block, was in Chicago holiday week with his lines.

H. S. Noyes, manager here for Bates & Bacon, is spending holiday week with his parents at his old home at Newburyport, Mass., and will visit the factory before his return.

"This has been the hardest working season the employes of the wholesale houses have ever seen," remarked an old-timer, "and this, despite the fact that never before were there so many men employed."

The territory formerly covered by the late J. H. MacCormick for the Waterbury Clock Co. has been divided between Fred L. Pettee and C. A. Kreich, western travelers for the company, each extending his territory over that previously covered.

W. Edward Copeland, son of W. A. Copeland, of Martin, Copeland & Co., who came to Chicago to assist the western office during the pre-holiday rush and who has been at it till 12 o'clock every night since, returned east Friday to spend the holiday season at home.

Representatives of eastern manufacturers say that while the volume of trade has been exceptionally large, they never knew an easier season for selling goods. There were a good many shortages in all lines, but if the buyer could not get what he wanted he took something else—in fact, had to—and he accepted the situation cheerfully.

The store of A. Strassburger, 483 Lin-

coln Ave., was made very attractive for the holidays by an entire new refitting in quarter-sawed oak showcases, in which the glass extends to the floor, making the lower part of the case a fine exhibition space for silver ware and the larger articles generally consigned to the wall cases. This allows more room for the diamonds and gold stock, which have become Mr. Strassburger's specialties.

It may be said that no buyers in person showed up in Chicago the past week. This does not include the nearby trade, who have nearly all appeared as purchasers of special articles ordered by their customers, but is intended to mean the outside trade, not so often seen here. In the volume of orders that poured in, the week was a remarkable one, and there were many of the employes as they wended their way home in the small hours of Sunday morning who were thankful that the crush of the closing days of 1899 was over.

The affairs of the International Silver Co., so far as regards Chicago, are rapidly assuming tangible shape. A. L. Sercomb, whose name is unconsciously associated with that of the Meriden Britannia Co., from his long connection with their affairs in the west, will have the Chicago management and be in complete charge of the International's interests here. The location of the new salesrooms has not as yet been definitely decided upon. It is understood to be the intention of the company to secure sufficient room, an entire floor at least, in a central location, where each of the firms represented in the International Co. will have its separate display and office and be under its own manager, the arrangement to form a homogeneous whole, which will be under the direct supervision of Mr. Sercomb. This will effect a large saving in the marketing of the products of the various factories, curtail the expenses of each of the individual plants, and give the International Co. facilities for conducting their business on economic lines. The details of the new quarters, pending the decision as to location, cannot yet be given out, but it is safe to assume that with Mr. Sercomb at the Chicago helm a salesroom will be evolved that will not only be a Mecca for all western jewelers, but may, in the course of events, be the nucleus for a new jewelry center in this city.

### Pacific Coast Notes.

Charles Tucker & Son, Durango, Col.,

will discontinue their jewelry business about the first of the year.

B. J. Morey, Corning, Cal., intends to erect a new brick building next Spring, which he will occupy when completed.

C. C. Sullivan has been found guilty of burglary in the first degree for complicity in the robbery of A. O. Gott's jewelry store, Alameda, Cal., on the night of Oct. 8. On that occasion his accomplice, Bert Willmore, was shot and killed while resisting the attempts of the police to arrest him. Sullivan was recommended to the mercy of the court.

### Pacific Northwest.

Chas. F. Easton, Wallace, Idaho, is closing out his business.

The stock of M. A. Miles, Salt Lake City, Utah, has been sold out by the Sheriff. The stock brought \$312.

Chas. Temple has moved his stock of jewelry into new quarters at Hood River, Ore., and now has a very neat little store.

E. C. King, jeweler, Tekoa, Wash., has purchased an interest in the Silver Leaf mining claim, situated in the Seven Devils country in Idaho.

B. Rydberg, jeweler, Red Lodge, Mont., has supplied the court room and also the recorder's office at that place with handsome clocks finished in oak to match the furniture.

B. M. Jenney, Weiser, Idaho, will move his stock of jewelry and repair outfit to a new building. The place is arranged very nicely, and Mr. Jenney will make his present stock one of the largest and best in that part of the country.

A. H. Burnie has been arrested in Portland, Ore., for the theft of a diamond ring. Fritz Abenbroth, jeweler, identified the prisoner as the man whom he supposed stole a \$100 diamond ring from his store Nov. 24 last. Burnie had not the ring in his possession when arrested.

Albert Feldenheimer, jeweler, Portland, Ore., has presented to the American Cockeyed Hat Association a handsome silver cup of elegant design which he offers as a prize to the winner of the "Big Four" match tournament. The trophy will be known as the Feldenheimer Big Four trophy.

Robert S. Weaver, Miamisburg, O., advertises that he is going out of business.

Edgar J. Leiff, Denver, Col., has given a chattel mortgage on his fixtures amounting to \$80.

**St. Louis.**

THE CHRISTMAS TRADE.

The holiday business is best described by those interested.

Chas. H. Schoen, with the International Silver Co., Holmes & Edwards and Barbour branches: "The holiday season of 1899 will long be remembered as one of exceptional prosperity."

Morris Eisenstadt, Eisenstadt Mfg. Co.: "Just what increase we will have this year over last I don't know, but please remember 1898 was a very prosperous year. Still I will be surprised if we individually don't have over a 20 per cent gain."

Edwin Massa, Bauman-Massa Jewelry Co.: "What of business? Well, we will have a gain of 50 per cent, and every jobber in town will have a big gain."

Among the retailers the same unanimity exists as to good business. Thos. D. Witt, of Eugene Jaccard Jewelry Co., reports trade as better than 1898, a very prosperous year. Herman Mauch said he was almost too busy to answer questions, something that had never occurred to him before. Geo. R. Stumpf has his store handsomely decorated with palms, and says he is immensely pleased with Christmas trade. Gerhard Eckhardt says he believes there will be few complaints in the trade this year.

Very few of the traveling fraternity were with us last week. Among them were: F. R. Horton, Carter, Hastings & Howe; Fred. J. Foster, Unger Bros.; John W. Case, F. H. Carpenter & Son; Wm. J. McQuillin, Hodenpyl & Sons.

Out-of-town jewelers here last week were: F. S. Brickey, De Soto, Mo.; S. O. Harvell, Litchfield, Ill.; A. T. Brewster, Hillsboro, Mo.; Wm. Brazeale, Pacific, Mo.; M. B. Dunman, Franklin, Tex.; F. Courvoisier, Freeburg, Ill.; Fred. Simon, Collinsville, Ill.; I. J. Schwendt, Ste. Genevieve, Mo.

**Detroit.**

Jeweler H. P. Beardsley has opened a store at 135 Michigan Ave.

The Economy Optical Co. have started a store at 85 Grand River Ave.

The following traveling salesmen passed through Detroit last week: R. H. Schley, Sloan & Co.; L. E. Smith, M. B. Bryant & Co.; W. S. Noon, W. F. Cory & Bro., and P. M. Layman, Riker Bros.

The report comes from Sault Ste. Marie that a Kimberley expert has discovered a true diamond formation in the wilds of Canada, between Michipicoten and Port Arthur. The exact location is being kept a profound secret. It is reported that Montreal capitalists will organize a company to exploit the fields.

A stranger who refuses to give his name smashed in the plate glass window in Mrs. S. E. Newcombe's jewelry store, Big Rapids, so as to get into jail. He helped himself to a lot of souvenir spoons and walked off. He was locked up. The damage to the window is estimated at \$125, and Mrs. Newcombe must stand the loss.

Pereira's jewelry store, 209 Gratiot Ave., was damaged to the extent of \$1,500 by fire last week. The window was being decorated for the holidays and the blaze caught from a gas jet. Miss Etta Pereira, daughter of the proprietor, narrowly escaped death as her clothes caught on fire. A fireman tore off her dress. The stock was partially insured.

**Cleveland.**

THE CHRISTMAS TRADE.

Christmas trade has been exceedingly good at all the local jewelry houses, and the proprietors are wearing broad smiles. Not in years has the demand for the better classes of goods been so large, and the run on stocks of staples has been phenomenal.

A \$250 pair of diamond earrings was stolen from the display window of Schauweker Bros. Co., Colonial Arcade, some time last Monday afternoon. The loss was not discovered until the store closed in the evening. How the theft was accomplished is a mystery, as the earrings were lying near the window and three feet from the sliding doors on the inside of the store. The doors were kept closed except when a clerk had occasion to open the window to take from it some article desired by a customer. M. L. Mowery, a clerk, said that the store had been crowded all day Monday, and the slides had been opened several times to show jewelry.

Mr. Warman, of Urbana, O., has an old Seth Thomas clock which was purchased and used by John Washington, a cousin of the immortal George Washington and the father of Mrs. Warman. The timepiece has the date 1828 and was in Mr. Washington's family 60 years. It is still a good timekeeper and Mr. Warman has it in his office as a curiosity. Not long ago he computed the time John Washington spent in winding the clock while he owned it and found that it was a trifle over 30 days of 10 hours each.

1850

**"BELL-POST" BUTTONS**

1900

WILL NOT BEND OR BREAK.

CONSTRUCTION  
PROTECTED  
BY PATENT  
JUST ISSUED.

A SAVING  
IN LABOR OF  
50%.

PRICES  
REDUCED TO  
CORRESPOND.



A NEW LINE  
FOR  
A NEW YEAR.

EVERY PAIR  
GUARANTEED.

OUR  
GUARANTEE IS  
BASED ON  
50 YEARS OF  
SUCCESS.

100 NEW STYLES—SOLID GOLD—NOW READY.

JOHN T. MAURAN MFG. CO.,

New York Office:

Makers of Gold Jewelry.

3 MAIDEN LANE.

Factory: PROVIDENCE, R. I.

### Cincinnati.

#### THE HOLIDAY TRADE.

The retail jewelers say they have not had such a holiday trade in years. They have had messenger boys all week to accommodate their customers. Thursday and Friday were the greatest days, and it was almost impossible to get waited on in some of the stores. A great many sales were lost through this inability to be served.

Robert S. Weaver, Miamisburg, O., after holiday trade will hold an auction sale to close out his stock.

Clemens Hellebush sold last week among the holiday sales, one brooch for \$3,000. It was a large pink cameo set with karat stones.

A. K. Lyon, Lexington, Ky., came up to Cincinnati last week after more goods. He had splendid sales. M. Barney Wolf, Moscow, O., came after more watches.

O. E. Bell is making preparations to go to Cuba the first week in January on a month's prospecting tour. He will establish Cuban agencies for the Bell Watch Case Co.

George McGraw, who lives near Little River, Ky., reports that he has discovered a pearl bed in the river and he brought here about 50 specimens, which were examined by some of the local jewelers.

The Queen City Watch Case Co. have several new men in their factory and have been very busy working on special gold cases. They expect to have plenty of work to keep them rushed up to the first of the year on present orders.

Henry Cowan's jewelry store, 1316 Main St., was entered by thieves Wednes-

day night last and about \$40 worth of jewelry and other goods stolen. The thieves got in through the front door by forcing it open when no one was near.

Ezekiel & Bernheim, auctioneers, conducted another auction sale last week of a first class stock of jewelry, watches and diamonds supposed to be the stock of a retiring jeweler outside the city. The goods were sold mostly in lots.

Charles Epstein, 18, errand boy for the Duhme Jewelry Co., was arrested last week after he had enlisted in the army. Mr. Keck, of the Duhme Jewelry Co., claims that the lad forged receipts for packages he was sent to deliver and appropriated the goods.

Walter Farrell, for many years the western and southern representative of Aikin, Lambert & Co., New York, and the John Holland Gold Pen Co., Cincinnati, O., died at Longview asylum, near Cincinnati, a few days ago. He was buried in St. Joseph's cemetery, Walnut Hills.

The Wadsworth Watch Case Co. have closed up the largest business year since they have been in existence. They have already begun to make up Spring stock. Their new factory is rapidly approaching completion and as soon after Spring trade as possible they will be ready to occupy it.

Since the much mooted question of the 20th century has not been settled a Cincinnati young lady says she thinks some enterprising manufacturer ought to get out a 20th century pin or souvenir for exchange among friends and she suggests the century plant in enamel as the emblem

on the same. This seems a pretty good idea.

Few jobbers sent out any selection packages this year. They needed their goods at home, and it is safe to say the eastern men will find depleted stocks on their next trip after Christmas. This means good sales, as the jobbers will be obliged to stock up for the Spring trade. There is a great dearth of 16-size movements. It is said only two houses in town have any. Hundreds of sales have been lost this Fall owing to the scarcity of movements.

The Board of Supervisors, sitting as a Board of Revision, were addressed by attorney Rankin D. Jones Dec. 23 on behalf of the Duhme Jewelry Co. It appears that the company had returned their stock of merchandise for taxation at a valuation of about \$10,000. To this the Board of Supervisors as a Board of Equalization added \$49,000. This Attorney Jones, speaking for the company, maintained is excessive and unwarranted in comparison with the taxable valuations placed on the stocks of other jewelry stores in the city. He argued that the original return of the company was a fair one in comparison with the returns of other jewelry stores, and therefore requested the board to take off the addition it had made to the returns. The case will be further considered by the board this morning (Dec. 27).

### San Francisco.

J. P. Jepson, New York, arrived in this city on Dec. 19.

Mr. Wilcox, of the International Silver Co., is in San Francisco recuperating.

The stock of King, Moss & Co., 639 Market St., is being sold out at auction.

F. E. Smith, San Jose, Cal., was in San Francisco last week buying more stock.

Henry Rothschild, of Rothschild & Hadenfeldt, returned from the northwest a few days ago.

William Wilson, Oakland, and M. Cohn, of M. Cohn Co., Oakland, were buyers here the past week.

F. T. Keeler, Skaguay, Alaska, is in San Francisco on business. He expects to remain here about a month before returning.

Chas. J. Harris & Son, manufacturers of watch cases, were burned out in the fire which destroyed the Bush St. theater, this city, a few days ago.

James Schell, Douglas Island, Alaska, has sold out his jewelry store at that place and is now in San Francisco looking for a location somewhere in California.

L. C. Koberg, Healdsburg, Cal., was in San Francisco buying stock last week. John Hood, Santa Rosa, Cal., was a trade visitor in San Francisco a few days ago.

James Kite, formerly in the employ of E. Valentine, Juneau, Alaska, arrived in San Francisco on the last steamer. He is now looking for a location in California.

Harry B. Smith, a salesman in the employ of Shreve & Co., was arrested some days ago charged with theft. He pleaded guilty to petty larceny and admitted having stolen at different times to the amount of \$67. Sentence has not yet been imposed.

Jennings & Clifford have bought the H. L. Wilson jewelry stock, Platteville, Wis.

# AUCTION

A  
\$150,000  
Stock.

**A. K. CAMP CO.,**  
MILWAUKEE, WIS.

The above firm are retiring from business and are having the most marvelously successful auction sale ever held in Wisconsin. It is under the supervision of the jewelers' auctioneer,

**P. J. BURROUGHS, 103 State St., CHICAGO.**

**Georgian** STERLING SILVER.

In Complete Table Service—

French Gray Finish.



**TOWLE** MANUFACTURING CO.,  
CHICAGO.

NEWBURYPORT, MASS.





**WATCH CASE GUARANTEES.**

**THE RETAIL JEWELERS SPEAK OUT AND GIVE THEIR IDEAS ON AN IMPORTANT MATTER BEARING UPON THEIR TRADE.**

[This series of letters began in issue of Nov. 15.]

It was upon the request of several responsible jewelers that THE CIRCULAR entered upon the undertaking of obtaining a consensus of opinion from the retail trade regarding the guaranteeing of gold filled watch cases, and sent to a large number of jewelers, indiscriminately, a letter of which the following is a copy:

NEW YORK, Sept. 8, 1899.

WE ARE SENDING THIS LETTER TO THE RETAIL TRADE WITH THE OBJECT OF GETTING THEIR VIEWS ON AN IMPORTANT SUBJECT, NAMELY: THE GUARANTEEING OF FILLED WATCH CASES. FROM THE RESPONSES RECEIVED MAY BE EVOLVED SOME VALUABLE SUGGESTIONS.

OF THE FOLLOWING FORMS OF GUARANTEE, WHICH DO YOU CONSIDER MOST JUST, AND WHAT ARE YOUR ARGUMENTS ON THE SUBJECT?

1. SHOULD THE MANUFACTURER GIVE A NEW CASE OF THE SAME GUARANTEE IN EXCHANGE FOR THE OLD CASE THAT HAS NOT LIVED UP TO ITS GUARANTEE?
2. SHOULD THE MANUFACTURER EXCHANGE THE CASE THAT HAS NOT LIVED UP TO ITS GUARANTEE WITH ONE OF LOWER GUARANTEE? THAT IS, IF A 20-YEAR CASE HAS BECOME DEFECTIVE AT THE END OF 10 YEARS, SHOULD IT BE REPLACED WITH A 10-YEAR CASE?
3. SHOULD THE MANUFACTURER REPAIR THE CASE AND PUT IT IN CONDITION TO OUTLIVE THE UNEXPIRED TERM. IF THE CASE SHOWS THE BASE METAL BEFORE THE LIFE OF THE GUARANTEE HAS EXPIRED?
4. SHOULD HE GIVE A NEW CASE AND CHARGE FOR THE LENGTH OF TIME THE CASE THAT DID NOT LIVE UP TO ITS GUARANTEE HAS BEEN WORN; IN OTHER WORDS, REBATE FOR THE UNEXPIRED TERM OF GUARANTEE?

YOURS VERY TRULY,  
THE JEWELERS' CIRCULAR PUB. CO.

All those jewelers who did not receive this letter are cordially invited to send their views upon this subject, replying to the questions seriatim or collectively. Their replies will receive the same measure of consideration as those received direct from the letters themselves. The more views on this subject expressed by the trade at large the more convincing will be the conclusions reached.

[Seventh series of replies.]

MELROSE, Mass., Nov. 20, 1899.

Editor of THE JEWELERS' CIRCULAR:

In regard to the guarantee on filled cases, would say that I have only one view on the subject, and that is if a manufacturer guarantees a case for 25 years, and if it is worn off so as to show the base metal before that time he should replace it with another as good. I sent back to a supposed reliable manufacturer a case which was guaranteed for 20 years. The owner had had it for 10 years. The manufacturer sent me a cheap screw case, which I think was a five-year case. I did not like the pattern, which was nothing like the old one. I sent it back, but could not get anything different nor could I get the old one. My customer is not satisfied. What can I do? He will never buy another filled case. I do not think the maker made any-

Yours,  
W. A. SMITH.

NEWPORT, R. I., Nov. 17, 1899.

Editor of THE JEWELERS' CIRCULAR:

In regard to gold filled watch cases it seems to me that charging on a new case for the time the old case has worn is giving too much to the manufacturer. If a case is guaranteed for 20 years it should wear 20 years, or a new case should be given that will wear the length of time guaranteed. The manufacturer has the benefit of the chance of the case being lost or transferred to another party, or the owner not caring to make a fuss about it, while the retail dealer bears the odium of the customer complaining to his friends and acquaintances "how he got cheated at the dealer's store," thereby somewhat losing his good name. I feel most satisfied in selling a filled case when the dealer stamps his name and guarantee inside the case.

D. C. DENHAM.

BOLAR, Va., Dec. 19, 1899.

Editor of THE JEWELERS' CIRCULAR:

Being a reader of THE CIRCULAR I feel interested in the discussion now being carried on respecting filled watch cases, and as you invite opinions, I shall venture mine. I am with those who favor proposition No. 1 of your letter, and my reasons are these:

When a customer purchases a 20-year case and pays the price of same, he, of course, expects to get what he pays for, and rightly, too. Anything else would be an injustice. I notice some of your answers from jewelers favor proposition No. 2, but let us examine it a little, if you please. If a 20-year case only wears 10 years is it reasonable to suppose that a 10-year case of same make would wear full time (10 years)? In my judgment if a 20-

year case wore only 10 years it would take another case of equal quality to wear the remaining 10 years of the guarantee. I have had a great deal of trouble with filled and rolled plate cases. I used to handle a lot of five and 10 year cases, and my experience has been that the majority of five year cases as guaranteed by leading manufacturers will wear off in from six months to one year. The inside back cap, the bezel and pendant and bow will wear off inside six months. The 10-year cases wear about 18 months to two years.

This is simply ridiculous, and something should be done to suppress such guarantees. I have in three instances had 20-year cases made by reliable (?) manufacturers wear off in from two to four years.

You have raised a subject of much importance to the retail jeweler and wearer of filled cases, and I trust the discussion will cause the makers of filled cases to either put more gold in the cases or reduce the time of their guarantees to what they should be.

I am in for proposition No. 1 all the time, but would rather see the quality of the cases improved so no exchange would be necessary, and the time is coming when such will of necessity be done or filled cases will be supplanted by something more reliable.

Let the good work go on.

Very truly yours,

G. L. EAKLE.

FREMONT, O., Sept. 12, 1899.

Editor of THE JEWELERS' CIRCULAR:

Would reply to your queries:

1. Yes.
2. No. If the manufacturers did, the 10-year case may not wear over five years.



# Our New.... Jewel Case



has been pronounced by competent judges the best in size, shape, workmanship and fitting, in the market.

**Roy Watch Case Co.,**

Makers of SOLID GOLD CASES,

21 Maiden Lane,

New York.



TRADE-MARK REGISTERED.

3. This would fill the bill if the manufacturer stated in his guarantee: "We will repair case or replace it with a case of the same value."

4. This would not prove satisfactory, simply because the manufacturer guaranteed the case to wear 20 or 25 years as may be.

Yours truly,  
J. H. BIHL.

COLUMBUS, Ind., Sept. 14, 1899.

Editor of THE JEWELERS' CIRCULAR:

In reference to your questions will say:

1. Yes.
2. No.
3. If it could be done satisfactorily this might do.

4. The manufacturer should give a new case without extra charge.

Yours respectfully,  
H. L. ROST.

HOPKINSVILLE, Ky., Nov. 29, 1899.

Editor of THE JEWELERS' CIRCULAR:

In regard to the filled case guarantees, in my opinion the first proposition would be unjust to the manufacturers. The second would be just and should be satisfactory to all parties concerned. The third should be also if the repairs can be successfully made. The fourth is not practicable and would entail trouble and dissatisfaction all around. This subject is timely and will be interesting to jewelers. I had my first case a few months ago to set right.

Respectfully, etc.,  
M. D. KELLY.

CONCORD, N. H., Sept. 12, 1899.

Editor of THE JEWELERS' CIRCULAR:

In reply to your questions:  
1. What is the guarantee good for if not?

2. No.
3. Give a new case.
4. Manufacturers should make them as they guarantee them.

Yours truly,  
N. G. CARR.

BARNESVILLE, O., Sept. 11, 1899.

Editor of THE JEWELERS' CIRCULAR:

In response to your questions would say:

1. Yes. Full guarantee is promised and expected.

R. GAMENTHALER.

OSKALOOSA, Ia., Sept. 14, 1899.

Editor of THE JEWELERS' CIRCULAR:

In reply to your questions I will say:

1. Yes.
2. No.
3. No.
4. No.

Yours truly,  
C. W. BOLLINGER.

NEWPORT, Pa., Dec. 4, 1899.

Editor of THE JEWELERS' CIRCULAR:

You did not send me circular in regards to watch case guarantee, but as I have been in business for 27 years I have had some experience with the guarantee. 1st. The manufacturer should give a new 20 year case for a 20 year. 2d. No; he should not give a 10 year in exchange for the 20 year. 3d. No; he should not repair the case, but give new one. 4th. He should give new case, but not charge. When I sell a 20-year case to a person I guarantee it for 20 years and tell him that if it wears off in less than 20 years to bring it back and I will give him another free of charge. My conscience would not allow me to give him a repaired case or a 10 year case; nor could I charge him extra, as that was not in the contract when he bought. I might just as well charge a man a fraction of a dollar if I put in a mainspring and guarantee it for one year and it breaks in nine months after. If I should sell a case and have trouble with it I should certainly expect the manufacturer to give me a 20 year for a 20 year case. Yours truly,  
W. H. GANTT.

(Series of letters to be continued.)

An instructive little brochure has been issued to the trade upon the construction of the Holmes & Edwards Silver Co.'s sterling silver inlaid table ware and the superior wearing quality of pieces so made. To prove the comparative amount of wear between an ordinary plated spoon and one of the "Sterling Inlaid" spoons, the concern constructed a drag testing machine, arranged with a wheel, or disk, revolving underneath a spoke-like frame. Attached to this frame are the spoons to be tested, with the bowls resting on the rough oaken disk. A cyclometer registers the distance that the spoons are dragged over this surface. The character of the wear that the spoons get in moving over this surface is identical with what they would get in being moved over a table-cloth, except that the test is much more severe. In this machine were placed spoons of ordinary plate, others of triple plate, and some "Sterling Inlaid" ware. The following figures give the distance that each kind of spoon was dragged before the silver was worn off so as to show the metal underneath: Amount of wear of ordinary plate, drag test showing 5,620 feet, equal to 1 1-15 miles; amount of wear of better grade or triple plate, drag test showing 22,640 feet, equal to 43-10 miles; amount of wear of "Sterling Silver Inlaid," drag test showing 457,740 feet, equal to 86 2-3 miles.

## Another Victor.

When the crucial test comes, when quality tells, side by side with the conquerors Olympia and Raleigh stands

## THE BOSTON.



O size, 3 rows of pearls, made in Montauk, 20 years' guarantee, and 14 F.K., 25 years' guarantee.

**Joseph Fahys & Co.,**

Established 1857.

FAHYS BUILDING, NEW YORK.

**Philadelphia.**

THE CHRISTMAS TRADE.

"The market for our holiday goods," said a prominent manufacturer to THE CIRCULAR reporter, "has been healthier this year than ever before. Trade has been given an unexceptional impetus and retailers have every reason to rejoice." This sentiment is echoed by all other jewelers in the local trade, and by opticians as well.

Mr. Block, of Block & Bergfels, New York, was in town last week.

Wm. J. Scott, optician, formerly of 1608 South St., has moved to 1604 Pine St.

John Wanamaker has presented to the University of Pennsylvania an important collection of Etruscan jewelry.

James Bathgate, formerly of J. E. Caldwell & Co., is now with Gimbel Bros. as buyer for the jewelry department.

Judge Finletter is expected to hand down a decision in the bankruptcy proceedings of L. A. Scherr & Co., this week.

William Wagner, nephew of General Wagner, formerly of Butte City, has bought out Thaddeus S. Adle, Norristown.

The cutlery and silver ware establishment of T. James Fernley, 505 Commerce St., was affected slightly by fire last week.

The Philadelphia Jewelry Mfg. Co. made an assignment Dec. 18 for the benefit of creditors to John G. Rosengarten and William D. H. Wilson.

W. S. Johnson, a clockmaker of New York, delivered a lecture before the Franklin Institute, Wednesday night, on the manufacture of tower clocks.

James D. Hughes, wholesale jeweler, will move Jan. 1 from 730 Chestnut St. to 111 S. 8th St. He has an elaborate catalogue in preparation for the trade.

Among the buyers in town last week were: B. C. Foster, Bristol, Pa.; E. C. Albertson, Bridgetown; Jacob Hopper, Tuckertown; Howard Fitzsimmons, West Chester; M. F. Davis, Wilmington; Harper & Taylor, Salisbury; B. F. Schlichter, Limerick, and P. F. Griest, Gloucester, N. J.

Ann Gibson, aged 80 years, has been locked up charged with the attempted larceny of a gold ring from Mrs. H. S. Ford's jewelry store, 618 E. Girard Ave. The aged woman had visited the store and asked to be shown some rings, and was leaving without purchasing when Mr. Ford missed a valuable ring from the tray. He ran around the counter, and, seizing her, found the ring in her hand, he alleges, and he then called a policeman.

**Birmingham, Ala.**

THE CHRISTMAS TRADE.

Never in the history of Birmingham was the town so full of people as last week, and the jewelers all report a large business. Thousands of people from outside points were here to buy their Christmas jewelry.

Alex Henderson & Co., Troy, have put in a big line of staple jewelry.

I. Dalheimer is selling jewelry at auction at Mobile through the holidays.

J. W. House has opened a jewelry business at Hollins, Ala., where he has a stock and a work bench.

The Montevallo Jewelry & Optical Co. have just opened for business at Montevallo. J. H. South, formerly with the C. N.

Maxwell Jewelry Co., Tuskaloosa, and later in business for himself at Montevallo, is manager of the new concern.

**Utica, N. Y.**

A. W. Rice has removed from Utica and opened a repair and jewelry business in Sherburne.

A. P. Wilcox, who has been in the employ of C. C. Shaver, silversmith, in the capacity of bookkeeper, has accepted the district agency for Oneida and Herkimer counties, with the Home Life Insurance Co., New York.

W. S. Taylor, 62 Genesee St., the veteran jeweler, has something to boast of inasmuch as he has been continuously in business 50 years, and says he has also been in business the greatest number of years of any jeweler between New York and Buffalo. Mr. Taylor is hale and hearty and is about 75 years of age.

**Kansas City.**

Dr. W. W. Watts has opened an optical department with Gurney & Ware.

T. G. Burkhardt, Jefferson City, Mo., has returned from a short eastern trip.

I. M. Jackson, Topeka, Kan., has redecorated his store and put in new fixtures.

The holiday trade has far eclipsed past seasons for several years. The number of sales are very large, and the sales have been of a much more expensive nature than in former years.

**Boston.**

Derry & Bigelow succeed Derry & Hennigar, the jewelry house on Temple Place, Mr. Hennigar retiring from the firm on account of prolonged illness and being succeeded by Edward A. Bigelow, the popular Boston representative of the Courvoisier-Wilcox Mfg. Co.

**The Color of Gems.**

ACCORDING to Tschermak, the formation of the color of precious stones and other minerals is not easily explained in the majority of cases. The dye-stuff contained in them may belong to an organic as well as an inorganic compound, but almost always its quantity is so small that it does not suffice for a chemical analysis. In the mineral zircon, which is much used as a gem, especially under the name of hyacinth, the yellow, green, red or brown color can be ascribed to the presence of nitrogen, and the same thing has been proven for the well known smoky quartz, which is very often erroneously called smoky topaz. The origin of the coloring of the amethyst has not been determined as yet, but the opinion that it was due to the presence of a compound of sulphocyanide with iron has been found to be wrong. In many minerals the color is caused by the presence of chrome. This has been a long established fact as regards certain varieties of garnet, spinel and diopside (a variety of augite). But other highly prized gems owe their color to chrome, as the red and violet spinel, the ruby, the sapphire, the Oriental amethyst, the green zircon, and the topaz of Villarica, Brazil. In the ruby and the sapphire, it is true, chrome could not be discovered direct, but it was established in the opposite way, that the combination of the elements constituting the said gems and potassium bichromate produces colorless metals, on the one hand, but also red, blue, yellow and green ones. Thus, numerous other examples might be cited, in which the cause of the coloring of minerals might be ascertained, but a much larger number of colored minerals remains, whose color the chemists have not yet explained.—*Engineering and Mining Journal.*

A hand-drawn illustration of an envelope. The flap is open and contains a message written in cursive: "Happy & Prosperous New Year to you!!". Below the envelope, the text reads: "J.A. Bergfinner, 82 & 84 NASSAU STREET, NEW YORK." To the right of the address, it says "To All + Every One of our Many Friends." At the bottom, it lists "Jewelry & Silverware Cases, Trays & Paper Boxes."

CONSULT

“The New York Jeweler”

Before Buying Jewelry or Kindred Lines.

For 26 years the acknowledged authority for all that is new, artistic and beautiful in the Jewelry World.



An idea of the assortments illustrated is shown by the fact that there are over 1000 Designs in Diamond Jewelry; 2000 Designs in Watches; 3000 Designs in Emblems; 5000 Designs in Gold and Silver Novelties; and proportionate displays from our silversure, Clock, Cut Glass, Lamp, Musical, Photographic, Optical, Scientific Instrument, Leather and Fine Stationery Departments.

724 Pages. Size, 9x13.

This profusely illustrated catalogue enables the dealer to make a better selection than the majority of travelers' stocks affords.

S. F. MYERS CO.,

MANUFACTURING and WHOLESALE JEWELERS

Myers Building, 48-50 Maiden Lane, New York.

Mention Dept. G 12 when sending for catalogue.

Survival of the Fittest.

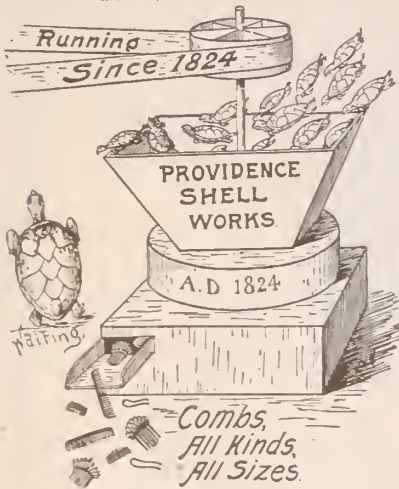

POTTERS COMB FACTORY, PROVIDENCE, R. I.

We Grind for You, Send along your Work.

JULES J. LINTZ,

Watch and Chronometer Maker

FOR THE TRADE.

Two Diplomas and First Prizes for Scientific Workmanship.

108 Fulton Street, New York.

DOWNING BLDG., ROOM 1019.

Repairing of Fine and Complicated Watches Pocket and Marine Chronometers.

All kinds of New Pieces made to order and adjusted.

The Latest Patents.

ISSUE OF DEC. 19, 1899.

639,371. MACHINE FOR FORMING OPTICAL SURFACES. PAUL GAUTIER, Paris, France. Filed April 4, 1899. Serial No. 711,734. (No model.)

639,438. CLOCK STRIKING MECHANISM. HERMANN W. J. ROSIN, Schramberg, Germany. Filed Feb. 17, 1899. Serial No. 705,885. (No model.)



In a striking mechanism, the combination, with a revoluble volute wheel provided with a separable end piece, of a pivoted controlling-lever provided with teeth which engage the said volute wheel and its end part, and tappet mechanism operating periodically to separate the said end part from the body of the volute wheel thereby releasing the said lever.

639,578. REGULATOR FOR HAIR-SPRINGS OF CLOCKS OR WATCHES. OLOF JOHANSON, New York, N. Y. Filed Feb. 20, 1899. Serial No. 706,286. (No model.)



In a hair-spring regulator and in combination with the hair-spring, and its regulator-arm, a pair of regulating-pins of which both are flexible and elastic and of which one is provided with a head projecting laterally far enough to close the end of the space between the pins in the normal position of the latter to constitute a positive barrier against the introduction and removal of the hair-spring coil and not so far as to exceed the limits of elasticity of said pins when these are spread apart by provision independent of any separating tendency of the spring-coil, the flexibility of each of the pins allowing it to yield a part of the distance required for the removal of the said head out of the way of the hair-spring coil which is normally lodged in the space between said pins.

639,586. STRIKING-CLOCK. ALMERON M. LANE, Meriden, Conn. Filed Nov. 29, 1895. Serial No. 570,369. (No model.)

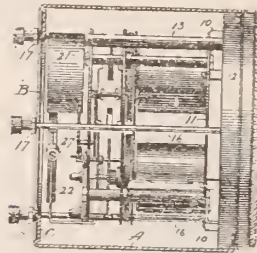

In a striking-clock, the combination of a metallic circular body for transmitting sound, the gong post or standard rigidly supported by the front part of the case and extending to the rear thereof, the sounder and gong secured to the rear end of said standard at the back of the clock-movement and means for effecting a firm union of the front end of said standard with the front portion of said case-body.

639,587. CLOCK-SETTING MECHANISM. ALMERON M. LANE, Meriden, Conn. Filed May 19, 1899. Serial No. 717,397. (No model.)

639,630. CLOCK-WINDING INDICATOR. ALFRED TUCKER, Hassan, Minn. Filed June 15, 1896. Serial No. 595,578. (No model.)

In a mechanism of the class described, the combination with a cam disk or pinion secured to and actuated by a clock-shaft and having a laterally-projecting stud or pin, of a tripping-wheel having slotted teeth adapted to receive said stud, said wheel being also provided with a stud, a tripping-lever actuated by the tripping-wheel stud, a spring-

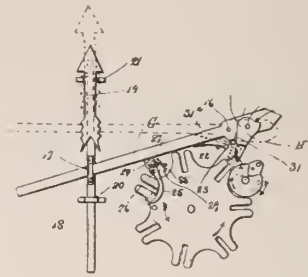

actuated and pivoted second lever normally coupled to the tripping-lever, but released therefrom when said tripping-lever is actuated by the tripping-wheel, and an indicator-slide connected to and actuated by the said second lever when the latter is released from the tripping-lever.

DESIGN 31,993. HANDLE FOR SPOONS, Etc. WILLIAM C. CODMAN, Providence, R. I.,



assignor to the Gorham Mfg. Co., same place. Filed Nov. 22, 1899. Serial No. 737,958. Term of patent 7 years.

TRADE-MARK 33,902. CERTAIN NAMED SILVER WARE. GORHAM MFG. CO., Providence, R. I. Filed Nov. 22, 1899.



Essential feature.—A representation of three raised panels placed side by side. Used since Jan. 1, 1853.

TRADE-MARK 33,903. CERTAIN NAMED SILVER WARE. GORHAM MFG. CO., Providence, R. I. Filed Nov. 22, 1899.



Essential feature.—The representation of a shield surmounted by an eagle. Used since Jan. 1, 1898.

TRADE-MARK 33,905. CERTAIN NAMED POTTERY. GRUEBY FAIENCE CO., Boston, Mass. Filed Nov. 1, 1899.



Essential feature.—The representation of a lotus flower. Used since Oct. 26, 1893.

Enamelled flower pins have revived some of their old time popularity. Violets, single and double, pansies, daisies and wild roses all tempt the shopper.

# OPTICAL DEPARTMENT.

Note.—From this week till further notice this department will be run as usual, viz.: every other week.

## Encyclopedia-Dictionary and Reference Handbook of the Ophthalmic Sciences.

Copyrighted 1898, by The Jewelers' Circular Pub. Co.

By R. H. KNOWLES, M.D.

[Commenced in issue of July 6, 1898.—Continued from  
page 41, Dec. 13, 1899.]

### PART XLII.

**Logadoblenorrhoea** (*log-ad-o-blen-or-rhe-a*). [Greek, *logades* = the sclera + *blenna* = the mucus + *reo* = I flow.] A catarrhal inflammation of the conjunctiva with an excess of a flow of the morbid elements upon the cheeks.

**Long sight** (*long sight*). [Middle English, *long* = long + *sight* = vision.] A misnomer having the same meaning as hypermetropia. A state or condition of the eyes in which rays of light from the distance point, traveling in parallel paths, in passing through the dioptric media, will focus behind the retina with the muscle of accommodation at rest. The eyeball in long sight is too short; a convex spherical lens will, therefore, correct this condition.

**Lotion** (*lo'-tion*). [Latin, *lotio* = a lotion or wash.] A solution containing medicinal substances to be used as a wash. An eye lotion or eye-wash contains either astringent, antiseptic or soothing substances employed as local applications to the eyes. Synonyms: **Eye-wash**; **Collyrium**.

**Loxophthalmos** (*lox-oph-thal'-mos*). [Greek, *lochos* = oblique + *ophthalmos* = the eye.] A turning of the eye from parallelism. Synonyms: **Squint**; **Strabismus**; **Heterotropia**.

**Lucifugal** (*lu-cif'-u-gal*). [Latin, *lux* = the light + *fugere* = to flee away.] A desire to get away from bright light.

**Luminiferous** (*lu-min-if'-er-ous*) [Latin, *lumen* = the light + *ferro* = I bear.] That which has the power to emit light.

**Luminosity** (*lu-min-os'-it-y*). [Latin, *lumen* = the light.] That which has the quality of being luminous.

**Lunella** (*lu-nel'-la*). [Latin, *luna* = the moon + *ula* = little.] A crescentic collection of pus in the dependent portion of the anterior chamber of the aqueous humor. Synonym: **Hypopyon**.

**Lunet** (*lu-net*). [French, *lunette* = a little moon.] A lens prepared and worn in an eye glass or spectacle frame. This term is employed by astronomers and the savants of Europe and in the United States referring to instruments in general which assist vision, telescopes, field and marine glasses, etc., etc.

**Luscitas** (*lus'-cit-as*). [Latin, *luscus* = one-eye.] A state or condition, congenital or acquired, in which one eye is good as to

vision and its mate is in the state of amaurosis or permanent blindness. This condition may be associated with convergent strabismus in which the squinting eye has lost its function of sight and in which the state of amblyopia exanopsia results.

### M.

**M.** The thirteenth letter of the English alphabet is the abbreviation for meter, misc (mix) and other technical words, and also represents the number 1,000.

**McAllister, John.** Born in Scotland 1753; died in 1829. In 1796, established an optical house in Philadelphia, Pa., which has been continued by his son and grandson.

**Macropia** (*mac-ro'-pi-a*). [Greek, *makros* = large + *ops* = the eye.] The seeing an object larger than it really is. Temporarily, this is due to paralysis of accommodation. Permanently, this condition is developed by the adhesive bands of lymph putting the rods and cones upon a stretch after an inflammation of the retinal elements has subsided. Synonyms: **Megalopsia**; **Macropsia**; **Makropsia**.

**Macropsia** (*mac-rop'-si-a*). [Greek, *makros* = large + *ops* = an eye.] A pathological condition of the eye in which an object appears larger than it really is; due to the disturbed relations of the rods and cones, after an inflammation of the retina has subsided. A temporary paralysis of the ciliary body will produce this state for a shorter or longer period of time.

**Macroscopic** (*mac-ro-scop'-ic*). [Greek, *makros* = large + *skopeo* = I see.] That which may be perceived by the naked eye.

**Macula** (*mac-u-la*). [Latin, *macula* = a spot.] A small spot or depression or even a discoloration on some part or organ of the body. The Macula Cornea Arcuata or the arcus senilis is a white ring near the sclero-corneal margin in elderly people or in those past the meridian of life; it is due to fatty degeneration of the cornea. The Macula Flava is the yellow spot in the sight area of the eye; synonym: Macula Lutea or the Spot of Saemmering. The Macula Lutea is the name most commonly employed to express the location of the sight area. This spot is seldom seen, but in a few patients a small, crescentic spot of pale yellow may be discerned located just a little outward above the optic disc. Generally the macula lutea may have the appearance of a bright red area apparently very deficient in small blood vessels, but, in fact, very vascular and containing, perhaps, more capillaries than any similar area in the human body. The center of the macula lutea is called the fovea centralis, and here the rods and cones or Jacob's membrane are as nearly perfect as it is possible for them to be. This is the area upon which the image forms its clearest and sharpest outlines.

**Maddox Glass Rod.** [Proper name + Anglo-Saxon, *glas* = glass + *rod* = to grow.] This consists of a cylinder placed in a sten-

opaic slit in order to make a test for muscular insufficiencies. The Maddox Prism consists of two prisms placed with their bases

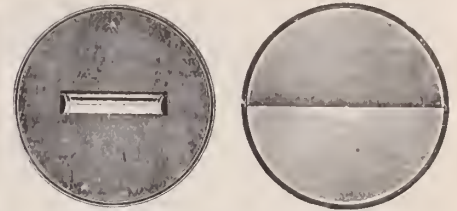

MADDOX SINGLE ROD. MADDOX DOUBLE PRISM.

joined, for the same purpose of demonstrating muscular insufficiencies.

**Madisterium** (*mad-is-ter'-i-um*). [Greek, *madistein* = to tear or pull out.] An instrument used for removing the eyelashes. Synonym: **Cilia forceps**; **Epilation forceps**.

**Magnet Operation** (*mag'-net op-er-a'-tion*). [Greek, *Magnesia* = a province in Asia Minor.] The loadstone, or the oxide of iron magnetized, is sometimes used to withdraw steel or iron imbedded within the tissues of the eye. The method for the removal of steel or iron by means of the magnet comes under this heading.

**Magnification** (*mag-nif-ic-a'-tion*). [Latin, *magnifican* = to render large.] A term employed in microscopy to signify the result of dividing the linear dimensions of the image seen by the linear dimensions of the magnified object.

**Magnify** (*mag'-ni-fy*). [Latin, *magnus* = large + *fi* = I make.] To render a proportionate increase in the size of an object.

**Makropsia** (*mak-rop'-si-a*). [Greek, *makros* = large + *opsis* = eye-sight.] The morbid state of the eyes in which all surrounding objects are enlarged; due to paralysis of the muscle of accommodation or to a disturbance of the retinal element. Synonyms: **Macropsia**; **Megalopsia**; **Macropsia**.

**Malacocataracta** (*mal-ac-o-cat-ar-ak'-ta*). [Greek, *malakos* = soft + *kata* = down + *raktes* = a fall.] A soft cataract which occurs in the crystalline lens of an individual under the fortieth year. This is an arbitrary division, as the varieties of hard cataract occur in an individual over the fortieth year.

**Malaris** (*ma-lar'-is*). [Latin, *mala* = the cheek.] That part of the orbicularis palpebrarum muscle which has its origin at the inner and lower angle of the eye and the contiguous structures of the nares, and finds its insertion close to the origin of the greater zygomatic muscle.

**Malaxation** (*mal-ax-a'-tion*). [Greek, *malasseo* = I soften.] The kneading or rubbing of the eyeball with the view of ameliorating pain or dispersing a congestion of the eyeball.

**Malpighi, Marcello.** Born in France in 1775; died in 1812. A celebrated anatomist after whom several parts of the human body are named, such as the malpighian bodies or follicles of the kidneys; the malpighian layer of the skin; the malpighian corpuscles or small white granules in the spleen. He employed the microscope in his investigations.

(To be continued.)

# THE LADY RACINE

IS THE

## Best Chatelaine Watch

10 Line,  
11 Line,  
12 Line,  
13 Line,  
Hunting or  
Open Face,



Nickel,  
Steel,  
Silver,  
Enameled,  
Gold,

**In new and tasty designs.**

Can be ordered from all Reliable Jobbers.

# CLYDE LINE

## TO FLORIDA

ONLY DIRECT WATER ROUTE BETWEEN  
**NEW YORK, CHARLESTON & JACKSONVILLE**  
WITHOUT CHANGE

SUPERB PASSENGER SERVICE	SAILING FROM • PIER 45 N.R. • NEW YORK	THREE SAILINGS WEEKLY
--------------------------------	--	-----------------------------

W<sup>m</sup> P. CLYDE & CO., General Agents.  
Theo. G. Eber, TRAFFIC MANAGER, 5 BOWLING GREEN, NEW YORK

### Dissolving Gold for Electro-Plating.

**T**AKE 5 grammes of brown fine gold, place it in a glazed evaporating vessel about 10 cm. in diameter, and pour a little aqua regia over it to dissolve it. This liquid, in order to form red gold chloride, would have to be composed as follows: Mix 15 grammes of pure hydrochloric acid and 8 grammes of pure nitric acid and heat the mixture slowly in the sand bath until the gold is dissolved, but without allowing it to boil. In order to evaporate the acid in excess, it is stirred slowly until a dark, oily liquid remains, which, on cooling, forms dark crystals of ruby color, requiring about  $\frac{1}{2}$  hour. Care has to be taken not to extend the process too long, otherwise the gold returns into its metallic state. The crystals are dissolved in  $\frac{1}{2}$  liter of water; to this add 15 grammes of ammonia previously dissolved in 150 grammes of water, whereby the gold is separated or precipitated as the technical expression is. The ammonia solution is best poured in gradually, stirring with a glass rod, but only as long as precipitate forms. The deposit is then well washed several times in hot water to expel the ammonia.

The gilding vessel, which should be kept at hand, must be an enameled iron pan with cover, holding about 2 liters. Fill it with water in which 62 grammes of pure potassium cyanide has been dissolved. This solution is poured in the evaporating vessel over a large basin upon the auric oxide salt. All dirt which might be present in the potassium cyanide will precipitate on the bottom of the dissolving vessel and can be removed. The potassium cyanide solution transforms the auric oxide salt into a pale liquid, which can now be poured back into the gilding vessel. Next, it only requires a heating to 71° C. to be all ready for the gilding. For this a fine gold anode, or thinly rolled gold plate weighing about 7.5 grammes is employed. A lesser weight is also sufficient, but if it is too small the gilding will turn out too pale. A bath thus prepared produces a beautiful, strong gilding which is very permanent, if one works with a gold anode, which is renewed in time.

Some prefer to dissolve the gold in an enameled gilding vessel and to continue the heating until the liquid has evaporated, next pouring in the potassium cyanide and water, until the precipitate forming at first is re-dissolved into a clear solution using the whole in this manner. The only drawback is that, if the enamel is cracked in places, the action of the iron of the vessel will convert the gold again into its metallic state. In this case the solution is soon exhausted, turning ineffective or producing an inferior gilding.

**Solder for Aluminium.**—To solder together two pieces of aluminium or the latter together with other metals, it is necessary to coat the places to be soldered with a mixture of tin and aluminium. For solder take 5 parts of tin and 1 part of aluminium. Solder with the iron or with the blow pipe, according to the article in question.



**Eliassof Bros. & Co.,**  
IMPORTERS AND JOBBERS OF  
**DIAMONDS, WATCHES, JEWELRY,**  
9-11-13 Maiden Lane,  
NEW YORK.

Materials, Tools and Optical Goods.

ALBANY OFFICE: 62 & 64 STATE STREET.

**William Kerr Still Active After 66 Years of Work at His Trade.**

ON Dec. 12 William Kerr, the old established watchmaker and maker of diamond saws, 543 Westminster St., Providence, R. I., observed in a quiet way



WILLIAM KERR, A WATCHMAKER FOR 66 YEARS.

the 82d anniversary of his birth. Mr. Kerr has been a watchmaker for 66 years. He still continues to carry on his business personally and maintains the high reputation for skilful work which he long ago made for himself and his workmen.

Mr. Kerr was born in Manton, a suburb of Providence, Dec. 12, 1817, and first embarked in business as a watchmaker in 1835, having previously worked for two years at the jewelry business with the old time firm of Pratt & Carr. In 1837 he went to Woonsocket, R. I., where for two years he worked with Billings Farrington, having already shown himself a workman of unusual skill. He went to Boston in 1840, remaining there for 10 years and carrying on the making of watches and gold and silver spectacles. He returned to Providence about 1850 and has since been located there.

While in Boston Mr. Kerr conducted a horological school, probably the only institution of the kind in the country at the time. He has invented several curious clocks, probably the best known one being one on which a little ball makes a zig-zag journey down an inclined plane which tilts back and forth at regular intervals. In 1879 he made a large working model of the Strasburg Cathedral clock.

Mr. Kerr manufactures diamond saws for the United States Government and for Harvard and Yale universities and other institutions of a similar nature. In 1884 he invented a machine for drilling watch jewels which makes holes of the fineness of a human hair. Although he has reached such an advanced age, Mr. Kerr seems to show no signs of losing his faculties.

**Alexander Weed—A Study.**

AT the present time, Alexander Weed, proprietor of the oldest established jewelry business in Stamford, Conn., is a very conspicuous figure in the government of the municipality. He is a member of the Board of Common Council, and, as chairman of the Sewerage Commission, is making a strenuous effort to have a system of sewers laid in the section of the city west of the Rippowam River. All the local contagions have their origin in this thickly populated, unsewered section. Six years ago, when the city was incorporated, an act was passed by the State Legislature authorizing the issuance of bonds to defray the expense of this sewer, but, owing to a strong and determined opposition to the project, Mr. Weed's predecessors never attempted to carry it out. But, despite the opposition, the cry of excessive taxation, and numerous assaults made on him by contributors to the newspapers, Mr. Weed, with his characteristic fearlessness, has gone right ahead, bringing the project to a point where the contract for the work is to be awarded. Even the institution of a suit in which, if the sewer is built, damages of \$25,000 will be claimed from the city by a man who owns property near the proposed outlet of the sewer, does not cause the jeweler-official to hesitate. In this and in other cases where he has summarily dealt with menaces to health, Mr. Weed has incurred the enmity of many, sometimes his patrons, but he says:

"I don't care; they soon forget it and are doing business with me in a little while. I never lose much by it."

Independence is one of Mr. Weed's most noticeable characteristics; public sentiment never sways him. As in public life, he is in business, independent and fearless. He is a great reader and no one enjoys a good joke better, yet he confesses that he "couldn't see the point" of a joke once attempted by a tea seller who hired a store adjoining his, and after whose unceremonious departure it was found that holes had been bored through the brick walls of the building directly behind the safe in which most of the stock of Alex. Weed's jewelry store reposes on nights, Sundays and holidays.

Our subject has at times obtained advertising in a manner that would do credit to a Barnum. A number of years ago he owned a pacer, his cherished "Gus," and in the Winter he made the main street a speedway. While horses were brought from far and near, Alex. Weed's "Gus" was never beaten. On another occasion he had the business center worked up to a "duel pitch," by frequent street quarrels with an editor whose paper was continually maligning, or "roasting," him. He wrote the "roasts" himself, the altercations were but shams, and he and the editor were really the best of friends. The published articles were sometimes so scathing that a horse-whipping for the editor was often expected.

Mr. Weed's business was established by his father, Alex. Weed the first, in 1848, and will probably descend to Alex. Weed the third, who is now chief clerk in his father's establishment. Both the present Mr. Weeds are veterans, the elder of the

Civil war and the younger of the Spanish-American war. Both are diamond experts and the firm does a large share of the trade that is done in Stamford in precious stones.

**Unique Collection of Pewter.**

THE most unique collection of pewter ware ever placed on exhibition in Lancaster, Pa., is now displayed in the windows of Arnold's store, Penn Square. The collection is the property of J. W. Kraft, a road salesman for V. Werkheiser, wholesale grocer, and is the result of years of collection in odd places over the country. There are 40 pieces in the set, only five of which were made in the United States, two in Philadelphia, two in New York and one in Baltimore.

The English ware has the London stamp, the dates being those of our Colonial era. The newest piece is a bowl, manufactured in Baltimore in 1832. The collection includes six soup plates, six dinner plates, tureen, two pudding dishes, tea pot, water pitcher with base, six table spoons, three lamps, two sugar bowls, cream pitcher, candle stick, and a number of odd plates.

Apropos of the pewter question Judge Pennypacker, of Philadelphia, wrote to Lancaster some time since, stating that he had in his possession a plate, pewter, stamped "Lancaster, 1781, I. C. Hall," thinking the Lancaster to be Lancaster, Pa. A careful search among the tax lists in the year mentioned developed no pewterer in Lancaster, Pa., at that time.

**Swiss Watch Exporting Trade.**

THE following figures, representing the exports from Switzerland of watches, watch cases, movements, detached parts and musical boxes, are issued by the Inter-cantonal Society of the Jura Industries:

SWISS EXPORT OF WATCHES, ETC.	
1891,	4,347,316 valued at about \$20,100,000
1894,	4,373,075 " " " 16,622,000
1897,	5,487,928 " " " 20,164,000
1898,	5,792,169 " " " 21,228,000

EXPORTS TO COUNTRIES IN 1898.	
Germany .....	\$5,151,000
Great Britain.....	3,756,000
United States.....	3,562,000

The finished movements sent to the United States (106,689 in 1898) are now put into American cases. Switzerland continues to import more and more cases of American make, the number having risen from 64,632 in 1897 to 230,289 in 1898. This great increase furnishes full reason for fear for the interests of the Swiss manufacturers of cases, expressed by our contemporary, *Solidarité Horlogère*, and quoted in THE CIRCULAR of Nov. 1.

William H. Evans, jewelry and music dealer, Red Oak, Ia., has given a realty mortgage for \$4,000.

C. O. Upper & Co., 287 Genesee St., Buffalo, N. Y., who recently decided to retire from the jewelry business, are auctioning their entire stock at a store on Main St., to where it was removed so as to be handled to better advantage.

# BRADLEY & HUBBARD MFG. CO.

Have produced for this season's trade the finest line of goods ever offered.

## Art Metal Goods,

PITCHERS, VASES, CANDELABRAS, FIGURES, BUSTS, TABLES, ETC.....

## Reception Lamps

WITH THE CELEBRATED "B. & H." and B. & H. RADIANT BURNERS. NEW AND ORIGINAL DESIGNS. HANDSOME AND EXCLUSIVE FINISHES.

Dealers are cordially invited to inspect the line of Samples at our SALESROOMS.

NEW YORK: 26 Park Place to 21 Barclay Street.

BOSTON: 160 Congress Street.

CHICAGO: 131 Wabash Avenue.

PHILADELPHIA: 714 Betz Building.

FACTORIES and OFFICES: MERIDEN, CONN.

# PAIRPOINT MFG. CO.

New Bedford, Mass.

## LATEST CONCEPTIONS

...IN....

Rich Cut Glass,

Silver Plate

...AND...

Table Ware.

38 Murray St., New York City.

Temple Building, Montreal.



## SOUVENIR SPOONS

We are up to the cash buyer. If you are a cash buyer, you must have our special circular on souvenir coffee spoons for cash buyers. We won't give you time, but we will give you price. No jeweler can afford to be without this circular, nor neglect to give us a chance to quote prices in the way of souvenir spoons or souvenir novelties. We have everything in this line.

**SIMMONS & PAYE,**  
"The Souvenir House,"  
129 Eddy Street, Providence, R. I.

## DR. KNOWLES'

...PRIVATE COURSE IN...

# Optometry.

SPECIAL RATES IN THE CORRESPONDENCE DEPARTMENT.

"EYE DEFECTS,"

A New Book, in cloth, Price, \$1.00.

For terms and important particulars, write to  
**R. H. KNOWLES, M. D.,**  
36 John Street, New York.

WOOD ENGRAVINGS.



TELEPHONE, 645 JOHN.



## FERD. FUCHS & BROS., SILVERSMITHS,

MAKERS OF STERLING SILVERWARE,  
34 East 29th St., - New York.

## WOOD & HUGHES,

Sterling Silverware Manufacturers,  
FINE PLATED WARE,  
No. 24 John Street, - New York.



**DEITSCH BROS.,**  
14 East 17th St.,  
New York.

LEATHER, SHELL,  
EBONY, IVORY.

**JACOT & SON, IMPORTERS,**

**STELLA AND IDEAL MUSIC BOXES.**  
39 UNION SQUARE, - N. Y.

**H. M. RICH & CO.,**  
Jewelry - Auctioneers,  
7 and 9 Franklin St.,  
BOSTON, MASS.

**ALOIS KOHN & CO.,** 4 MAIDEN LANE, SOLID GOLD CHAINS, Near Broadway, N. Y.

We call the attention of the Trade throughout the country to our line of

## LORGNETTE AND GUARD CHAINS.

Will send Samples on Memorandum on receipt of satisfactory reference. Correspondence Solicited.



GOLD SHELL.

"Buy direct from the manufacturer and get all that is coming to you."

SEND FOR OUR "HOT CATALOGUE, CONTAINING COLD FACTS AND PRETTY PICTURES."

**CLARK & COOMBS,**

86 WEST EXCHANGE ST., - PROVIDENCE, R. I.

WE ARE HEADQUARTERS FOR.....

Gold Shell Rings...



**ESSER & BARRY,** Largest Manufacturers of IMITATION DIAMOND JEWELRY IN AMERICA. Cheap and Medium Priced

Write us for samples of almost anything with an Imitation Diamond in it. MAIN OFFICE AND FACTORY, 101 SABIN ST., PROVIDENCE, R. I.





## THE RAMBLER'S NOTES.

WHAT THE RAMBLER SAW AND HEARD AMONG THE DEALERS IN ART POTTERY, CUT GLASS, BRONZES, ETC.

PREPARING FOR THE COMING SEASON.

THE present time, particularly this week, may be termed the between season with the importers of china, pottery and fancy goods generally, as well as with the American manufacturers of pottery and glass ware. To a great extent business is suspended until after the holidays, most firms being now engaged in stocktaking. Immediately after the first of the new year the importers of china will begin arranging the display of their import samples for the coming year. These samples will begin to be shown from some time after the first week in January until the middle of the following month, by which time the import season will be at its height.

INCREASED LINES OF POUYAT CHINA.

SHORTLY after the first of the year Paroutaud & Watson, 50 West Broadway, New York, who have been acting as the New York agents for the Société La Céramique, J. Pouyat, Limoges, will materially add to the lines they have heretofore been carrying. While still continuing to be the exclusive American agents for the white and decorated Pouyat china, they will, in addition, carry a line of fine decorated glass ware and may, before the season is over, add pottery as well. Their import samples of Pouyat china will, during the coming season, show some of the most extensive and richest varieties they have ever offered to the jewelry trade.

THE RAMBLER.

### Sale of Old Keramics.

AT Bath (England) the following items of old china were sold by auction: A beautiful tureen with flower decorations, £9; suite of three 36 inch, Japanese pattern covered vases and two 24 inch beakers to match, £60; Chelsea figures, "The Seasons," £6; two 8 inch pastoral figures, Chelsea, £7 5s.; another, 11 inches, £18; a Worcester tea and coffee service, £21; two Bristol cups and saucers, £8 10s. The 200 lots, as will be seen by above selection, fetched very varied prices.

### American and English Potters Combining on Prices.

THE nucleus of the first industrial combination to include English and American manufacturers has just been formed in East Liverpool, O. At a meeting there of western potters, Charles W. Franzheim, of the Wheeling Pottery Co. and president of the National Manufacturers' Association, presented a proposition which he had just received at Trenton from the manufacturers there to consent to the proposed revision of the price list on crockery, provided there is an ironclad agreement to it on the part of the western manufacturers. The English manufacturers are willing to revise their prices contingent upon American potters taking a similar step. Mr. Franzheim assured the East Liverpool manufacturers that both the Trenton and English manufacturers will adhere to their propositions. A communication was then dictated, setting forth the willingness of the East Liverpool potters to adopt the new price, and is now on the way to England, where it will go before the manufacturers of the country, who will formally act upon and confirm it.

### The Disappearance of Sheffield Electro-Silver Plate.

THE Ironmonger, of London, England, recently sent a special commissioner to Canada, to enquire into the working of the Preferential Tariff and the results are now published in a special number. In England silver plate and electro plate are sold to a considerable extent by the hardware men, and the report of the commissioner upon these lines will be interesting to the American silver ware trade. The commissioner says: "Hardware men are not the distributors of Sheffield electro plated hollow ware in Canada as they are in the old country. This branch is left to the jewelers. \* \* \* I have only met one instance in which these goods were bought from Sheffield. Most of them are made in Canada, and a fair quantity is sent from the States. Soft, not hard metal, is the material used in the manufacture of Canadian electro plated hollow ware. It is cheaper and lends itself better to the florid decoration which is characteristic of American patterns. The English-made article undoubtedly lasts longer, but novelty and cheapness are the

qualities sought for in this class of goods; durability is a secondary consideration. Plated forks and spoons were until a few years ago bought from the old country; a few still are. 'Nevada' and 'Potosi' silver ware of British manufacture is occasionally imported, but Canada can now supply herself with these goods at a price which renders the importation of the English article impossible, when price is taken into account. The pattern in greatest demand resembles the well known 'Fiddle,' but the broad part at the top is considerably longer, and the shoulders at each side of the stem just above the bowl are frequently dispensed with. The 'Old English' pattern is also sold in some quantity. The chief Canadian firm manufacturing these goods has adopted, or rather copied, the name 'Nevada' silver."

### Gold and Silver Guns.

THE Gaikwar of Baroda, an Indian prince, who still rules under British suzerainty, has a great and gorgeous palace in Baroda, and seven miles out of the city, at Makarpura, a hunting lodge or Summer palace. A body guard of 150 strong men, mounted on handsome gray Arabian chargers, and dressed like Austrian husars, is posted about his palace, and with it a battery of artillery consisting of gold and silver guns.

There are four guns—two of gold and two of silver. The gold guns were made in 1874 by an artisan of Lakha, who worked on them for five years. They weigh 400 pounds each, and, except for the steel lining, are of solid gold. They are mounted on gun carriages of carved wood, overlaid with silver. Each gun is drawn by the finest team of bullocks which Baroda can furnish. The horns of these bullocks are encased in silver and gold, and they wear gold and silver anklets around their forelegs. On their heads are "mohadas," or headpieces of the same metals. Their trappings are of Kinob and Delhi work, and altogether the decorations of each team of bullocks are worth \$35,000. The silver guns were made by the same men as the gold ones, and are like them, except that they are a trifle smaller and weigh only 350 pounds each. The limbers and carriages of the silver guns are covered with brass, which shines like gold, and frequently is mistaken for that metal. In 1876, when the Maharajah Gaikwar went to Bombay, to meet the Prince of Wales, he took the gold guns with him.—Exchange.

### Queries by Circular Readers.

**Note.**—Questions under this department will be answered as promptly as possible. Some queries require careful investigation before a satisfactory answer can be given; hence such answers are often seemingly delayed. THE CIRCULAR desires every jeweler to take advantage of this department.

NEW YORK, Nov. 17, 1899.

Editor of THE JEWELERS' CIRCULAR:

Enclosed please find rough sketch of an antique clock that I have in my possession. I wish you would please let me know through your columns the origin and possible value of same. It is thrice size of dimensions given in drawing and is made

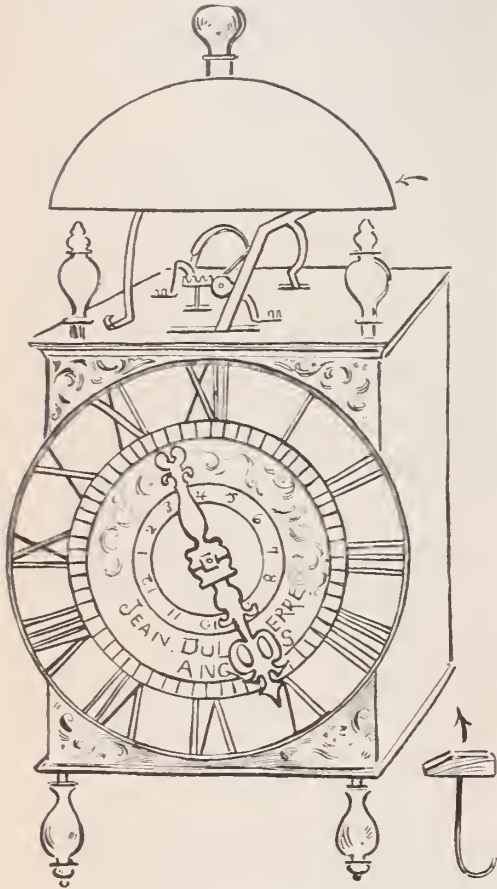

of brass and iron. The dial is gilt with engraved scrolls, and has name "Jean Du Lierre, Angers," in center.

Yours truly,  
"ANTIQUE."

**ANSWER:**—This clock is one of a great many made in various parts of Europe about the end of the last century, and, owing to the number now on the market, is of very little or no value as an antique. These clocks were practically an imitation

of the English King Charles wall clock (which has some value to-day) and in most instances bore the name of the local dealer scratched on the brass dial. This is probably the case with the clock here shown, as we can find no trace of a clock maker of the name Jean Du Lierre.

### Silver-Like Wire.

**S**ILVER-like wire is produced from rollable and ductile German silver. Such an alloy of a very handsome white color consists of copper 60 parts, zinc 20 parts, and nickel 25 parts. The mechanical working of German silver is hedged about with difficulties, inasmuch as the plates, which for the production of sheets have first to be obtained by casting, are highly crystalline and easily crack under the hammer, or at least become fissured at the edges. Generally small plates are produced by casting, which are 20 to 30 cm. in length, 12 to 20 cm. in width and one cm. in thickness. These plates are rolled slightly or hammered and calcined after every mechanical treatment. Thereby they gradually lose the crystalline structure, and when this has once disappeared they can be further treated without trouble. One is then able to give the plates, as well as brass, any desired shape, by rolling or stamping, and most articles of German silver (spoons, forks, etc.) are produced by stamping.

In the same manner the German silver worked in this way may be passed through rollers or wire drawing machines. Copper wire, brass wire, tombac and argentan wire are produced partly from square cast ingots, which are forged round, partly from cut wire bars, and first drawn on drawing piers; those from 6—10 mm. upon drawing discs. Copper wire draws less hard and is, therefore, usually only calcined once.

The coarser varieties of brass and tombac wire, continues the *Edelmetall Industrie*, are always put upon the market black, i. e., calcined after the last drawing, while the better grades are cold bright, either "light hard," i. e., drawn several times after the last calcining and pickling, or "light soft" if the wire, after calcination and dipping, has only passed one more sharp edged drawing hole, but inverted, where the drawing hole has rather a scraping than a stretching action. It need hardly be men-

tioned that imitation silver wire is copper wire with a fine coating of silver.

### Medals of Honor.

**M**EMBERS of Congress and others are continually proposing special medals of honor for officers and soldiers who have performed some specified service, or have distinguished themselves at some designated place, or in peculiar circumstances. All this is well enough, but it would be much better for the Government to adopt a regular medal system as all of the other leading States have done long ago. In the British army, for instance, every officer and man who goes through a campaign knows that, if he survives, he will receive a silver medal for that campaign, and if it includes a number of battles in each of which his regiment or command has been engaged, each of these events will be represented by a clasp duly engraved. Our Congressional medal of honor serves a good purpose and should be retained; but it does not cover enough ground. We should have at least three distinct military medals, with authority to the President to confer them on proper occasions. There should be one only to be conferred for actual and unusual heroism in battle; another for distinguished individual service in war, and still another for general war service. We have plenty of silver in the Treasury and engravers and die sinkers over in the Bureau of Engraving and Printing. The military committees of the two Houses ought to get together and prepare a measure to systematize the medal business.—*Washington Times*.

### American Competition for Foreign Trade.

**A**MERICAN manufacturers of silver ware and jewelry have long occupied themselves solely in catering for their huge home trade. But this is now evidently well supplied, and American silver plate manufacturers are looking outside the States for markets for their wares. We and other European countries may therefore expect competition in the near future in such countries as South America, Central America, South Africa, Australia, East Indies, West Indies and Eastern Asia, where American silver ware has as yet never, or scarcely ever, been seen.—*The Furnisher* (London).

## SILVER MEDAL AWARDED

... BY ...

NATIONAL EXPORT EXPOSITION, Philadelphia,

... TO ...

**C. F. Rumpp & Sons,** Established

1850.

PHILADELPHIA,

FOR

**HAND-CARVED LEATHER GOODS.**

SEND FOR ILLUSTRATED CATALOGUE.

## W. C. A. WESTPHAL,

WATCHMAKER,

41 Maiden Lane, NEW YORK.

Established 1892. Telephone, 3684 Cortlandt.

Estimates, Repairing, Adjusting of Chronometers, all Complicated Watches and Fine Time Pieces.

**DEMAGNETIZING.**

Watches made Non-Magnetic.

Fine Wheel and Pinion Cutting

TRADE



MARK.

Stamped in a Gold-Filled Watch Case means that it is absolutely warranted for

**25 YEARS.**

# American Watch Case Co.



Have Merit—Superiority—Reputation.

9 to 13 Maiden Lane, New York.

## CROUCH & FITZGERALD,



Jewelry Trunks and Cases,  
161 Broadway,  
Bet. Cortland and Liberty Sts.  
688 B'way,  
723 6th Av.  
NEW YORK.

## THE LEDOS MFG. CO.,

MANUFACTURERS OF

## Watch Case Materials,

Crowns, Pendants, Bows, Solders, Springs, Findings, Etc.,

34-36 PEARL ST., NEWARK, N. J.



**SIMONS BROS. CO.**

PHILA.  
NEW YORK  
CHICAGO

SILVERSMITHS,  
JEWELERS.

MAKERS OF GOLD AND SILVER THIMBLES.



## The Remington

Billing and Tabulating Attachment accomplishes all kinds of Billing, Statistical, and Accounting Work on the New Models of the

## Remington Standard Typewriter

as quickly and as accurately as ordinary typewriting is done. It automatically secures perfect perpendicular as well as horizontal alignment.



REMINGTON DEALERS EVERYWHERE SUPPLY IT.

# Push—Grit—Energy.

A long time ago we concluded that the only way to succeed was by practicing Push, showing Grit and never diminishing Energy. The result is shown in our

## 1900 Line of Jewelers' Findings

THEY INCLUDE

TUBE SETTINGS FOR COMBS, EBONY MOUNTS, PATENT CLUSTER SETTINGS.

## MEDALLION HEADS

FOR BROOCH PINS, BELT BUCKLES, LINK BUTTONS, ETC.

Large Scrolls for Picture Decorations and everything in Findings for the Manufacturer.

# HEIMBERGER & LIND,

158 PINE ST., METCALF BUILDING, PROVIDENCE, R. I.

"BY USING OUR GOODS, YOUR GOODS WILL SELL."

## Our Hand-made Cases

are constructed in the old reliable way, which is a pride to the Manufacturer, Dealer and Wearer.

STAMPED. TRADE MARK 18 K. ALL CASES BEARING THIS MARK, ARE HAND-MADE. TRADE MARK 14 K.

Manufactured by **DUBOIS WATCH CASE CO.,**  
Makers of **SOLID GOLD CASES.**

21 and 23 Maiden Lane, New York.



Plated Seamless Wire and Aluminum Solder.

144 PINE ST., PROVIDENCE, R. I.

# CHAS. F. WOOD & CO., DIAMONDS

1 MAIDEN LANE, NEW YORK.

IMPORTERS AND CUTTERS.

## DIAMONDS.

LARGE ASSORTMENTS.

DESIRABLE SIZES.

ATTRACTIVE PRICES.

**R., L. & M. FRIEDLANDER,**

**30 MAIDEN LANE, N. Y.**

97 HATTON GARDEN, LONDON.

## HALL CLOCKS,

*Mantel Clocks,*

*Traveling*

*Clocks,*

*Clock Sets,*

*Regulators,*

*Bronzes,*

*Vases, Ivory*

*Miniatures*

*and Art Goods.*



Fall Line Now Ready.

**Harris & Harrington,**

32 and 34 VESEY ST., NEW YORK.

Sole Agents to the Trade for J. J. Elliott & Co., London.

## HOROLOGICAL DEPARTMENT,

BRADLEY POLYTECHNIC INSTITUTE,

PEORIA, ILLINOIS.

Largest and best watch school in America. We teach Watch Work, Jewelry, Engraving, Clock Work, Optics. (Formerly Parsons' Horological Institute.) Catalogue Free.



## 38 YEARS OF HONEST RETURNS

IS OUR GUARANTEE OF SATISFACTION TO ALL OUR CUSTOMERS.

WE DO OUR OWN SMELTING.

**JOHN AUSTIN & SON,**

ASSAYERS, REFINERS AND SMELTERS,

74 & 76 Clifford St., Providence, R. I.

## BEER STEINS,

For Prizes, Club Use and Home Decoration.

75 Cents to \$4.50 Each.

**L. W. LEVY & CO.,**

Novelties and Optical Goods,

194 BROADWAY, NEW YORK.

Successors to Levy, Dreyfus & Co.

## TO BLOW EFFECTIVELY IS AN ART

which we never practice personally; but we have invented a machine which does it for us, called the

"Reichhelm Pressure Blower."

This, with Gas Furnaces and Jewelers' Tools generally, is the stock in trade of

**E. P. REICHELME & CO.,**

23 JOHN STREET, NEW YORK CITY.



GOLD AND SILVER PENCILS, PENHOLDERS, &c.



**FAIRCHILD & JOHNSON CO.**

Office and Factory,  
220 FOURTH AVENUE, N. Y.

## Satisfaction

AND....

## Promptness

is the secret of our success. Our chief aim has always been to render prompt returns and to give satisfaction to all our customers.

**CONLEY & STRAIGHT,**

GOLD AND SILVER

REFINERS, ASSAYERS and SMELTERS,

236 Eddy Street, PROVIDENCE, R. I.

## Horseshoe, Clover, Heart, Wishbone and Anchor.

THESE ARE A FEW OF THE THOUSAND DIFFERENT DESIGNS OF LUCKY BANGLES.

**S. & B. LEDERER CO.**

FACTORY: 100 STEWART STREET, PROVIDENCE, R. I.

New York Office, 11 John Street.

Chicago Office, 131 Wabash Avenue.

## EMPIRE COMBS. SIDE COMBS.

GOLD AND JEWELLED ORNAMENTED.

SPECIALTIES IN ROMAN WORK.

**DAY, CLARK & Co.,**

MAKERS OF FINE JEWELRY,

23 MAIDEN LANE, N. Y.

## PROV. STOCK CO. Chains

HIGH GRADE ROLLED PLATE

BRACELETS, LORGNETTES.

10K. GOLD

Scarf Pins, Brooches,  
Neck Chains, Lorgnettes,  
Bracelets.

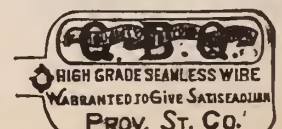

40 Stewart St., PROV., R. I. 11 John St., N. Y. 811 Vermont St., CHICAGO.

IMPORTERS AND CUTTERS OF DIAMONDS  
**Krinstein Bros. & Co.**  
 65 Nassau St. NEW YORK.  
 Cor. John.

IMPORTERS and Cutters.  
**L. & M. KAHN & CO.,**  
 172 Broadway,  
 Cor. Maiden Lane, N. Y.

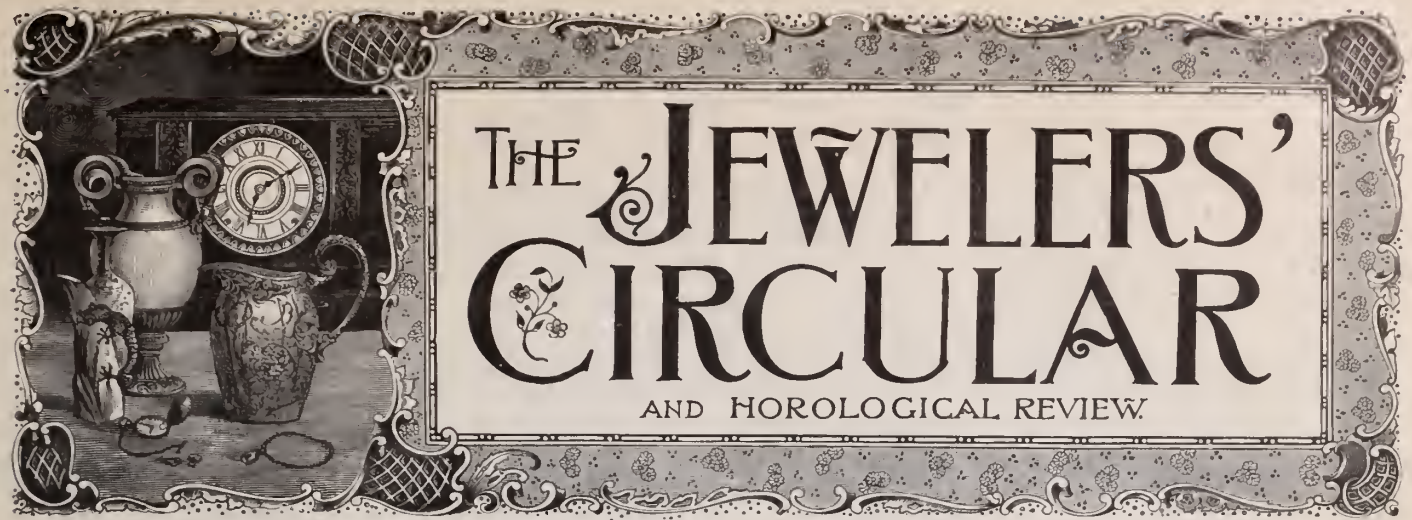

Corbin Building, 11 John St., Corner Broadway, New York.

Copyrighted by THE JEWELERS' CIRCULAR PUB. Co.

Entered at the Post Office in N. Y. as second-class matter.

VOL. XXXIX.

NEW YORK, WEDNESDAY, JANUARY 3, 1900.

No. 23.

THE HOROLOGICAL ART OF THE PAST.

THE finer productions by the masters in horological art of the past are always interesting, besides being often fruitful of suggestion to manufacturers of the present. The specimens here shown are re-

IV. is a watch case of chased silver of the 17th century. The watch and case are reproduced full size, while the clocks are much reduced. The engravings show the details of the designs and exterior plainly.

showing the phases of the moon, tells just what time it is in every city in the world. This is done by means of a globe which revolves inside a transparent globular glass. On this glass is marked a line



produced from *Alleg. Journal der Uhrmach-erkunst*. Plate I. is a table clock with horizontal dial. It is a product of the 16th century. Plate II. is a clock of the 16th century. Plate III. is a watch of the time of Louis XV., 18th century, while Plate

A Notable Timepiece.

JOSEPH JENSON, clockmaker of Richfield, Utah, has just completed a notable clock, which, in addition to striking the hours, halves and quarters and

which represents 12 o'clock noon. As the globe revolves this line is always over that part of the world in which it is noon at that time. Other lines represent the other hours and in this way it is easy to get the exact time in any given place.

# Now Is The Time

to place orders for the Spring season's goods. Our lines are better and larger than ever, and include all that is desirable to complete the stock of a modern, up-to-date jewelry store. The *quality* is the *highest*, the *styles* are the *best*, and the goods are made expressly for the regular, all-the-year jeweler.

Rolled Gold Plate and Gold-Filled CHAINS, BRACELETS, LOCKETS, CHARMS, PINS, EARRINGS, SILK RIBBON CHAINS, CHAIN MOUNTINGS, DUMBBELL BUTTONS, BROOCHES and BELT BUCKLES.

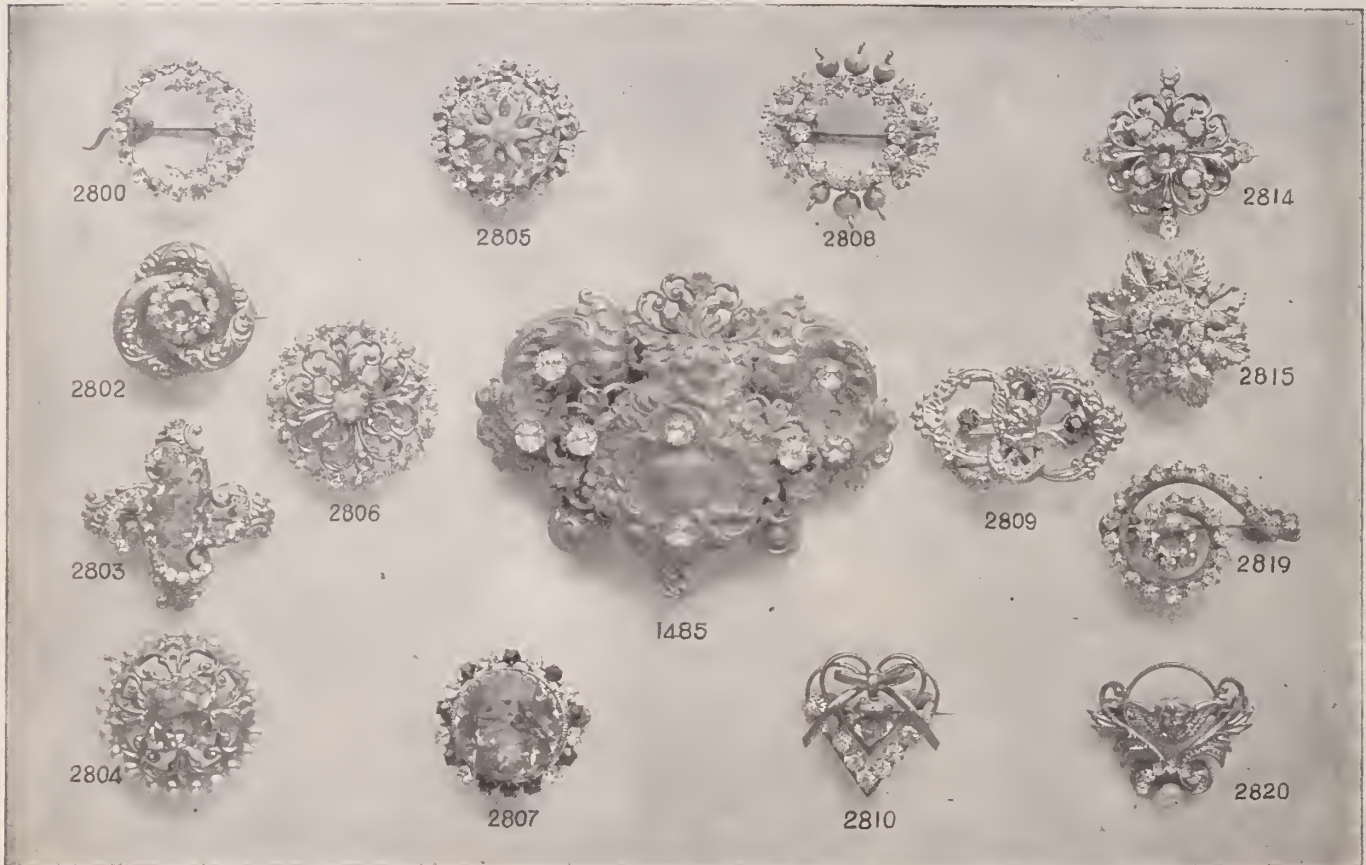

Our STERLING SILVER TOILET and MANICURE ARTICLES in the Washington, Jefferson, Victoria and American Beauty patterns are always in stock and can be matched or duplicated at any time.

**THEODORE W. FOSTER & BRO. CO.,** 100 RICHMOND ST., PROVIDENCE, R. I.  
Successors to FOSTER & BAILEY.

Established 1879. Manufacturer of

**LOUIS W. HRABA,**  **Fine Leather Goods**

29 East 19th St., New York. Exclusively for the Jewelry Trade.

**THE BASSETT JEWELRY CO.,**

Fine Gold-Filled Chains,  
Lockets and Gold Jewelry,

PROVIDENCE, R. I.

**AIKIN, LAMBERT & CO.,**  
MANUFACTURERS OF  
FINE GOLD PENS, HOLDERS, PENCILS,  
TOOTH PICKS and NOVELTIES.

PAUL E. WIRT FOUNTAIN PENS, at new and lower prices . . .  
MERCANTILE FOUNTAIN PENS, guaranteed to give satisfaction.

Catalogues with terms and discounts furnished to the trade.

**BRANCH, 103 STATE STREET, - - - CHICAGO.**

**AIKIN-LAMBERT JEWELRY CO.,**  
IMPORTERS OF  
**DIAMONDS.**  
JOBBERS IN  
**WATCHES, JEWELRY, CHAINS,  
NOVELTIES, ETC.**

**LATEST DESIGNS.                      LOWEST PRICES.**

**19 MAIDEN LANE, NEW YORK.**

# A Prosperous Holiday Trade,

we hope, was your good fortune to experience.

The time consumed in the salesroom during that interval had a natural tendency to cause an accumulation of work, and possibly you ran short of material beforehand, did not have the time to order and do not now have sufficient supplies for your future requirements. If these were the conditions, we should like and hope that you will not overlook the fact that we are able to help you out.

We increased our stock considerably during December, our dull season, believing that there would be more than a normal demand later on, and we are now fully prepared to cope with all emergencies that may arise and to replenish your stock in all departments.

Our equipment is modern and complete, facilities of the highest order, and our promptness all that could be desired. On these good points we base our past success.

We are grateful for your former favors and shall strive to merit a continuance of your appreciated patronage by rendering the best possible service.

In conclusion, we extend to you our best wishes for a Happy and Prosperous New Year.

## L. C. REISNER & CO.

Manufacturing Jobbers, Importers and Exporters,  
Watch Materials, Tools and Supplies,

Jewelry Repairers for the Trade.

LANCASTER, PA.

OPEN YOUR CAMPAIGN  
 FOR THE COMING SEASONS WITH  
 A STOCK OF FAHYS' RELIABLE  
 GOLD FILLED CASES

THE RALEIGH  
 THE CAMBRIDGE  
 THE OLYMPIA

Contain all the requisite features  
 of perfect gold filled watch cases

*Fahys*

*Trade Mark*

CATALOGUE ON APPLICATION  
**JOSEPH FAHYS & CO.**  
 ESTABLISHED 1857.  
 FAHYS BUILDING  
 NEW YORK



THE CAMBRIDGE



THE OLYMPIA



THE RALEIGH





GREETING :

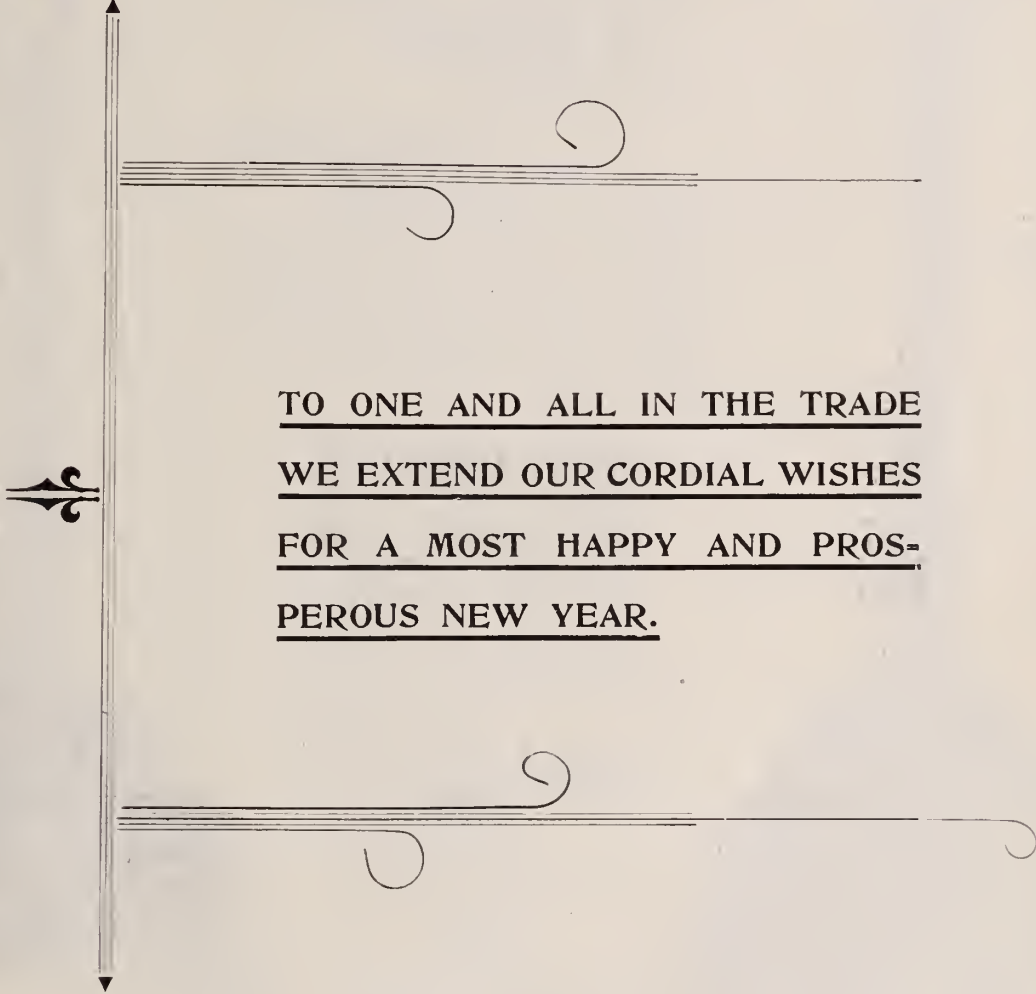

TO ONE AND ALL IN THE TRADE  
WE EXTEND OUR CORDIAL WISHES  
FOR A MOST HAPPY AND PROS-  
PEROUS NEW YEAR.

R. F. SIMMONS & CO.,

ATTLEBORO, MASS.

# "1835 R. WALLACE"

## "The Stuart"

WE HERE ILLUSTRATE  
OUR NEW PATTERN IN PLATED  
FLATWARE "THE STUART."

THIS PATTERN WAS ORIGINALLY INTENDED TO BE MADE ONLY IN A VERY FEW PIECES BUT ON ITS INTRODUCTION TO THE TRADE THE POPULAR FAVOR WITH WHICH IT WAS RECEIVED PROMPTED US TO MAKE THE PATTERN COMPLETE:

WE HAVE NOW READY FOR DELIVERY OVER FIFTY (50) DIFFERENT ARTICLES WHICH INCLUDE NEARLY ALL OF THE FANCY PIECES AND HOLLOW HANDLED TABLE CUTLERY

SEND FOR PAMPHLET NO. 12 ILLUSTRATING THIS PATTERN.

**R. WALLACE & SONS  
MFG. CO.**

FACTORIES,  
**WALLINGFORD  
CONN.**

BRANCHES-

226 FIFTH AVE. NEW YORK  
109 WABASH AVE. CHICAGO  
120 SUTTER ST. SAN FRANCISCO  
63 BASINGHALL ST. LONDON E.C.

SALAD  
SPOON.

SALAD  
FORK.

**Precious Stones: London Market.**

HATTON GARDEN, London, Eng.,  
December 18, 1899.

By the courtesy of the *Jeweller and Metalworker*, I am enabled to send an advance proof of my Annual Report on Precious Stones, to be incorporated in the Diary of that publication: R. F.

PRECIOUS STONES IN 1899.

Business in the jewelry trade pure and simple has been marked by considerable fluctuations in volume, but it is probable that when balance sheets are made out it will be found to have been a prosperous year. Manufacturing has been harassed by the vicissitudes which have characterized the gem market, especially during the latter half of the year. It can fairly be described as a diamond and pearl year. Gem merchants made their principal harvest in the first quarter, some of the houses doing more business up to April than in the whole of 1898.

Court mourning was a deterrent to business among shopkeepers in the early months, but a number of ultra-fashionable weddings in the Spring and Summer restored the balance. Society functions in these later months have been fewer than usual on account of the war, and the number of officers killed has thrown many families into mourning. The revival of the earring has been a notable feature of the year, its growth in popularity being steady and continuous. Birmingham jewelers report that the demand is mainly for the Creole shape; but in London, where manufacturers cater for a higher class of trade, the patterns have been of the closely-fitting descriptions, more correctly styled ear-studs, and usually of diamonds. Hair ornaments of various kinds have had a good run, buckles and buttons also have been selling in quantities. Unfortunately the high price of diamonds and the popularity of paste ornaments have resulted in an economical choice, to the detriment of the jeweler. Charms in a multitude of designs have been made and imported, but only a small percentage have any connection with precious stones. The same may be said of the immense quantity of "sequins" and other garnishings used by the dressmakers and described in fashion reports as "silver," "pearls," etc. The skirt pin has had another good time, and "lace"

brooches, being worn in greater numbers and for more purposes have to a great extent superseded the larger patterns. Enamel work has been increasingly utilized, but has not assumed anything like the position it holds in Paris; it is probable nearly all the fine work is still done abroad.

As to colored stones there is but little to say. Emeralds have kept up in price; fine stones are still fetching high figures and are hard to obtain, but there seems to be a good supply of second rate stones. Rubies, as usual, in good demand; spinel rubies and ruby beads have been especially mentioned. Sapphires, opals and olivines have been wanted in fine qualities. Fancy stones of all kinds, including fine fancy colored diamonds, have sold well. Turquoises appear to have had an exceptionally good year, if the jewelers' stocks and shop window displays are any criterion. Topazes have gone off in company with garnets. Semi-precious stones have not had such a good sale as in the previous year; muff-chain gems, rondelles, beads, etc., not being so much in evidence.

*Pearls* have had a rattling good year. The total of sales, despite high prices, must have been very great. Supplies were reported bare early in the year, and throughout there has been great difficulty in getting fine specimens, but in medium sizes and qualities, smalls and halves, there seems to have been a great business done. The rise in price is difficult to estimate, statements varying so widely; probably from 25 per cent to 30 per cent is about the mark in all but the finest descriptions. "Ropes" appear to retain their popularity, and smaller jewelry is abundant in pearls.

*Diamonds*.—The war between Spain and America had an appreciable effect upon the diamond market during 1898. This year the Transvaal war has been a disturbing factor, but the difficulties of the market began long before hostilities commenced. Advances in price of "rough," which form the basis, but do not represent the full measure, of the rises in polished stones, occurred in January, May, July, September and October. They amounted in all to 35 per cent to 40 per cent, being nominally 10 per cent in January, 5 per cent in the next three months named and two 5 per cent rises in Octo-

ber. Buyers complained, however, that through the inferiority of the quality of the stones, the advance *ad valorem* was really greater. As regards the rise in cut stones many estimates have been published, but it is probably within the mark to put it down at between 60 per cent and 70 per cent. Of course the advance differs according to the quality and size, the supply of low class stuff being plentiful and cheap in comparison with pure and larger stones. An immense business was done in the early months, the market being well boomed. The advent of war and the cutting off of supplies proved a sustaining force, which enabled the Syndicate to make further advances. The Syndicate itself had to advance its contract with De-Beers from 26s. 8d. to, it is supposed, 32s. 6d. per karat—an advance of 20 per cent. This, however, has been so variously reported that no one is sure of the exact figure. The relief of Kimberley and the reopening of communications will ease the market, but at the moment of writing nothing definite is known. Before the mines are in full working order again, and consignments are resumed, there is likely to be a good deal more trouble for diamond dealers. The trade generally has taken the situation cautiously, buying only for immediate needs; it can hardly be said to have profited by the enhanced values. Although recently business has improved among diamond mounters, in the first few weeks of the war, and after the two advances in rough in October, business fell off.

The increased prices of diamonds and pearls have greatly stimulated the auction sales, very good figures being obtained for all good stuff. R. F.

**Jeweler's Store Burglarized During His Temporary Absence.**

NEW BRITAIN, Conn., Dec. 26.—The jewelry store of Charles M. Hultgren, Vega block, Arch St., was entered by thieves, Monday afternoon, and ransacked. Jewelry and other goods to the value of \$150 were taken. Entrance was effected through a rear window. Mr. Hultgren had his store open to noon, when he locked up and went home to dinner. He returned about 8 o'clock at night, and when he turned on the lights he saw that everything was in confusion.

SCIENTIFIC RUBIES	CATSEYES	SAPPHIRES	DIAMONDS	RUBIES	EMERALDS	PEARLS	PEARL NECKS	PEARL ROPES	Pearl Collarettes, mounted with Diamond Bars.
OPALS	<p><b>PEARLS, DRILLED AND UNDRILLED.</b></p> <p><b>PEARL ROPES, NECKS and COLLARETTES.</b></p> <p><b>We are buyers of American Pearls.</b></p>								
OLIVINES	<p>LONDON: <b>JOSEPH FRANKEL'S SONS,</b> 68 Nassau Street, 19-20 Holborn Viaduct. NEW YORK.</p> <p>TELEPHONE, 3899 CORTLANDT.</p>								
FANCY COLORED DIAMONDS and GEMS in PEARLS and PRECIOUS STONES.									

**DIAMONDS.**  
**Wm. S. Hedges & Co.,**  
 IMPORTERS OF  
**Diamonds and Precious Stones.**  
 DIAMOND JEWELRY.  
**170 Broadway, New York.**  
 26 Holborn Viaduct, London.

*Oppenheimer Bros. & Veith,*

*Importers and Cutters of*

*Diamonds*

*Dealers in*

*Watches,*

*Cor. Nassau and John Streets,*  
 (PRESLOTT BUILDING.)

*....New York....*

*Amsterdam,*  
*2 Tulp Straat.*

*London,*  
*45 Holborn Viaduct.*

**MOUNT & WOODHULL,** FORMERLY WITH LATE FIRM OF  
 RANDEL, BAREMORE & BILLINGS,  
 .... IMPORTERS OF ....

**Diamonds, Other Precious Stones, Pearls, Etc.,**  
**Makers of fine DIAMOND JEWELRY,**

26 MAIDEN LANE (SOUTHWEST CORNER), NEW YORK.  
 NASSAU STREET

JOHN C. MOUNT.

ADDISON W. WOODHULL.

RUBIES.

SAPPHIRES.

**C. G. MALLIET & CO.,**

EMERALDS.

14 MAIDEN LANE, N. Y.

DIAMONDS.

## The Bowden Rings

ARE COMPLETE IN VARIETY, CORRECT  
 IN QUALITY AND PERFECT IN FINISH.  
 WE MAKE EVERY VARIETY OF FINGER  
 RINGS

**J. B. BOWDEN & Co.,**

1 MAIDEN LANE,

NEW YORK.

### ELSIE BEE'S FASHIONS.

A LADY'S RAMBLES AMONG THE JEWELERS.

The fancy for setting diamonds or other brilliant stones in the jaws of a griffin or lion is a striking one of which an excellent variation is to attach the gem as a pendant from the mouth, thereby affording a freer display of its beauty.

Bewildering, fascinating and altogether indescribable are the soft shades of color shown in the undressed leathers used for chatelaine bags and purses.

Silver monogram finger purses in seal, walrus, alligator, elephant and other serviceable leathers are decidedly convenient and useful.

Favrile glass serves charmingly in electric light, candelabrum and lamp shades.

Old English tavern jugs with quaint inscriptions in rhyme and German steins with their characteristic national decoration continue interesting and not unduly expensive.

Every variety of chatelaine arrangement is in high popularity just now.

Newest and daintiest in cigarette cases for the feminine contingent are those of soft, undressed leathers in delicate gray or tan tones, with fastening jeweled with a turquoise.

Quite the swell affair of the moment in its line is the very fine chain of extra length punctuated with *cabochon* turquoises or carbuncles. And those wearers who note each passing wave of social caprice attach, at most, two pendants to their chain, but these must be of the richest and most beautiful or quaint and rare.

The fad for introducing tiny timepieces into all kinds of articles is exemplified in the holiday novelties. Watches are mounted in bracelets, card cases, purse tops, etc. The smallest yet noted is a bicycle watch in the form of a stud to be worn in the button hole. In ring watches the dial is usually set around with brilliants.

"Sets" represented an ingenious holiday feature; as, for instance, a "theater set" including lorgnette and chain, vinaigrette, bonbonniere, etc.

Bracelets afford two rather taking fads. One is the silver bracelet engraved with a favorite quotation from Shakespeare. The other consists in buying a plain gold band and passing it about in one's social world, so that favored friends and acquaintances may have the initials of their names engraved upon it. When its surface is thus decorated with two score or more of letters and monograms the affair is complete and ready to be worn for a time and then cherished as a memento.

ELSIE BEE.

**The Operations of Smugglers.**

The Treasury Department Supervising Agent's Annual Report on This Subject.

WASHINGTON, D. C., Dec. 29.—The annual report of the Supervising Special Agent of the Treasury Department says that the subject of the undervaluation of imported merchandise has had the constant attention of the officers of the division, and in many instances the results have been gratifying both to the Government and to reputable importing and manufacturing interests. The special agent in Europe and his subordinates have been indefatigable in the investigation of cases of undervaluation, smuggling and other irregularities, and substantial results have accrued from their work. Appraising officers frequently call for their aid, and they have submitted valuable reports upon a great variety of subjects, under conditions which have called for the exercise of tact and perseverance. They have had the cordial co-operation of many consular officers, and the Treasury Department has also received from the latter many valuable reports relating to the dutiable character of imported merchandise. The special agent's corps in Europe has been a very valuable auxiliary to the Customs service in this country.

On the subject of smuggling the report says that on the northern frontier diamonds and other commodities have been smuggled or attempts have been made to smuggle them into the country; seizures have been made, and in instances where evidence could be secured criminal prosecutions have been instituted. In one instance an officer of the Treasury Department concealed on the person of an alleged smuggler, and arrested the party. On the Mexican frontier similar operations have been detected. At the port of New York smuggled goods, valued at over \$41,000 abroad, chiefly diamonds, were seized and held for forfeiture. Numerous other seizures of smuggled merchandise were made by the officers, and the aggregate appraised value thereof was \$138,932.07, while 60 arrests for these and similar offenses were also made.

**Sudden Death of Edward Wood.**

COXSACKIE, N. Y., Dec. 27.—Edward Wood, who had been in the jewelry business in this town for about 30 years, dropped dead last Sunday evening, as he was about to start for church. Mr. Wood was a man of good principle and commanded the respect of all who knew him.

The jewelry store of Mrs. A. Kritzer, 233 Exchange St., Chicopee, Mass., was entered a few nights ago and about \$40 worth of goods stolen. Entrance was gained through a rear window, one of the iron bars which guarded it being pried aside and the window smashed. The articles taken included some gold chains from the window and an alarm clock, also some cards of collar buttons. There is no clue to the identity of the thieves.

ESTABLISHED 1840.

**Chester Billings & Son,**

Successors to **RANDEL, BAREMORE & BILLINGS,**  
IMPORTERS OF

1840 RANDEL & BAREMORE.  
1856 RANDEL, BAREMORE & CO.  
1880 RANDEL, BAREMORE & BILLINGS.

**DIAMONDS**

OTHER PRECIOUS STONES AND PEARLS.

58 Nassau Street,  
29 Maiden Lane, 22 Holborn viaduct,  
NEW YORK. LONDON, E. C.

DIAMOND JEWELRY.

...ESTABLISHED 1841...

A. CARTER. C. E. HASTINGS. G. R. HOWE W. T. CARTER. W. T. GOUGH.

**Carter, Hastings & Howe,**

TRADE  MARK.

MANUFACTURERS OF

**Gold Jewelry,**

9, 11, 13 MAIDEN LANE, NEW YORK.  
FACTORY, NEWARK, N. J.

**Pearls**  
**Opals**

Importers and Cutters **GOODFRIEND BROS.,** Precious and Imitation Stones  
9-13 Maiden Lane, N. Y. 174 Weybosset St., Providence, R. I. 10 Rue Cadet, Paris.  
TELEPHONE, 662 CORTLANDT.

**John F. Saunders,** Cutter and Importer of  
**DIAMONDS** AND OTHER  
PRECIOUS STONES.

FINE PEARLS A SPECIALTY.

68 Nassau St., cor. John St., Sheldon Building, Room 16, NEW YORK.

# PEARLS.

## Business Reasoning.

In doing business with "specialists" devoting all their time and attention to but one line of goods, the dealer reaps all the benefit of the specialists' expert knowledge.

We are specialists, with years of experience, a requisite to expert knowledge in our line.

## Alfred H. Smith & Co.,

182 Broadway, N. Y.

CHICAGO.

LONDON.

# DIAMONDS

And Other Precious Stones.

# NISSEN

*Ludwig Nissen.*



18 JOHN ST. NEW YORK

*Emil Knopf  
John W. Ruelker.*

We carry the largest, finest and most complete line of Mounted Diamond Jewelry of any house in America.

## Importations at the Port of New York.

Weeks Ended Dec. 30, 1898, and Dec. 29, 1899.

China, Glass and Earthen Ware:	1898.	1899.
China .....	\$39,008	\$28,687
Earthen ware .....	11,264	12,040
Glass ware .....	11,773	12,914
Optical glass .....	.....	1,889
Instruments:		
Musical .....	11,585	7,320
Optical .....	5,195	4,787
Philosophical .....	488	2,832
Jewelry, etc.:		
Jewelry .....	6,890	6,210
Precious stones .....	94,029	83,221
Watches .....	16,454	29,030
Metals, etc.:		
Bronzes .....	2,726	515
Cutlery .....	23,063	32,239
Dutch metal .....	4,553	3,473
Platina .....	49,374	51,724
Silver ware .....	920	540
Miscellaneous:		
Alabaster ornaments .....	211	835
Amber .....	729	159
Beads .....	1,526	1,348
Clocks .....	745	4,833
Fans .....	4,190	102
Fancy goods .....	6,435	2,109
Ivory .....	247	.....
Ivory, manufactures of.....	294	298
Marble, manufactures of.....	14,783	19,321
Statuary .....	5,351	15,892

## Coming Annual Meeting of the Jewelers League.

The 23d annual meeting of the full membership of the Jewelers' League will be held in Masonic Hall, corner of Sixth Ave. and 23d St., New York, on Tuesday evening, Jan. 16, 1900, at 7.30 o'clock p. m. The annual reports of officers and of the executive committee will be presented and an election held for president for one year; two vice-presidents (known as third and fourth) for two years; three members of the executive committee for the term of two years, and three members of the advisory board to serve two years.

The following are the nominations for officers to be elected: For president, Henry Hayes; for third vice-president for two years, John R. Greason; for fourth vice-president for two years, O. G. Fessenden; for executive committee for two years, C. E. Breckinridge, Bernard Karsch and David N. Smith; for advisory committee for two years, Samuel H. Levy, C. C. Offerman and W. A. Wightman.

The following amendment to the constitution and by-laws of the Jewelers' League is proposed:

*Present Constitution.*

### ARTICLE III.

Section 4. At every Annual Meeting of the League three advisory members of the Executive Committee shall be elected to serve two years, in place of those whose terms of office have expired.

*Proposed Amendment.*

Amendment. Amend Section 4, Article 3 of the Constitution to read as follows:

### ARTICLE III.

Section 4. At every Annual Meeting of the League, commencing with the Annual Meeting of January, 1900, nine advisory members to the Executive Committee shall be elected to serve two years, in place of those whose terms of office have expired, so that said Committee after January, 1901, shall consist of eighteen members.

The death occurred recently of B. E. Buckner, at one time in the jewelry business in Midlothian, Tex.

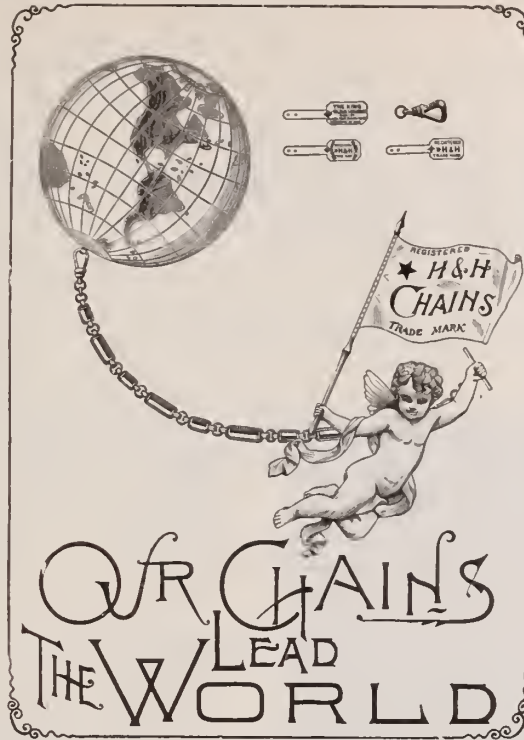

*To the Trade:*

*Accept our thanks for all favors and patronage bestowed on the*

**★ H. & H. Chains and...  
Silver Novelties.**

*To all our friends, old and new, we wish good health and a very happy and prosperous year, and trust that your highest anticipation for the year 1900 may be realized.*

**Hamilton & Hamilton, Jr.,**

*Providence, R. I.*

*New York, 11 John Street.  
Chicago, Stewart Building.*

*San Francisco, Claus Spreckles Bldg.  
London, 94 Hatton Garden.*

## Gifts for Men



In 14-Karat Gold—ORNAMENTED WITH PRECIOUS STONES—and in Sterling Silver. Goods that appeal to refined people at all times. Made handsomely, heavy and exclusively for the Jewelry trade.

**Woods & Chatellier,**  
Gold and Silversmiths.

860 Broadway, N. Y.  
42-46 Hill St., Newark, N. J.



“The  
Pearl  
House.”

We have no salesmen;  
call or write.

**EISENMANN BROS.,**

PARIS, 3 Rue St. Georges.

21 & 23 MAIDEN LANE, NEW YORK.

**MATHEWS & PRIOR,**

DESIGNERS AND MAKERS OF

**Sterling Silverware**

TO THE LEGITIMATE

**JEWELRY TRADE ONLY,**



245-247 West 28th Street,  
New York City.

**Stern Bros. & Co.,**

Cutters of . . .

MANUFACTURERS OF

**DIAMONDS, Gold Rings and Thimbles,**

68 NASSAU STREET, NEW YORK.

RING FACTORY, 33-43 GOLD STREET, NEW YORK.

LONDON OFFICE, 29 ELY PLACE

DIAMOND-CUTTING WORKS, 142-146 W. 14TH ST., NEW YORK. CHICAGO OFFICE, 149 STATE ST

## The Duty on Entire Watches.

**Judge Townsend Gives an Opinion on a Matter Important to the Watch Trade.**

The interesting customs suit, mentioned in the last issue of THE CIRCULAR, that involved paragraph 191 of the present Tariff act in its relation to entire watches was decided by an opinion rendered by Judge Townsend, of the United States Circuit Court, last week. The decision is against the importers and sustains the opinion of the Board of United States General Appraisers which the United States Government and the watch manufacturing companies of this country fought to have upheld. As before mentioned the action was on the protest of Jules Racine & Co. from the assessment of 40 per cent on watch cases which they claim should have paid but 25 per cent under the section of the Tariff law in question. The contentions of the Government and the importers were published in detail last week. Judge Townsend's opinion, which was delivered orally, is in full as follows:

"The merchandise in question consists of certain watches which were classified for duty by the Collector upon the cases and movements separately, at 40 per cent on the cases and at 25 per cent and the specific duty on the movements under the provisions of Paragraph 191 of the Act of 1897. The importers protested, claiming that the article was dutiable as an entirety at 25 per cent and the specific duty as watch movements in the case. Said paragraph provides as follows:

"191. Watch movements, whether imported in cases or not, if having not more than seven jewels, 35 cents each; if having more than seven jewels and not more than 11 jewels, 50 cents each; if having more than 11 jewels and not more than 15 jewels, 75 cents each; if having more than 15 jewels and not more than 17 jewels, \$1.25 each; if having more than 17 jewels, \$3 each, and in addition thereto, on all the foregoing, 25 per centum ad valorem; watch cases and parts of watches, including watch dials, chronometers, box or ship, and parts thereof, clocks and parts thereof not otherwise provided for in this Act, whether separately packed or otherwise, not composed wholly or in part of china, porcelain, parian, bisque or earthen ware, 40 per centum ad valorem; all jewels for use in the manufacture of watches or clocks, 10 per centum ad valorem. The construction of this paragraph is not entirely clear; but in view of the fact that in every prior Tariff Act watches have been held to be dutiable *eo nomine* at the same rate as watch movements, and that there is no other reference to watches in the present Tariff Act, I think the construction contended for by counsel for the United States is the correct one. He claims that each provision relating to jewels refers grammatically only to watch movements and that the following provision—and in addition thereto on all the foregoing, 25 per centum ad valorem—necessarily refers also only to these various classes of movements and not to the cases. In that event, inasmuch as the case would have lost its identity if treated as a part of the watch movement, as contended by the counsel for the importers, there would be no duty whatever on the value of the case. In short, the true construction would be as though it read 'watch movements, if not having more than seven jewels, 35 cents each,' etc., and there were added at the end of the first portion of the paragraph the statement, 'This shall apply to watch movements whether they are imported in cases or not.' The decision of the Board of United States General Appraisers is affirmed."

**JAMES KAHN'S SONS,**

PARIS: 7 RUE CADET.

IMPORTERS AND CUTTERS OF DIAMONDS,

Amsterdam, 2 Tulp Straat.

12, 14 & 16 John St., New York.



# DOLLARS ARE WHAT COUNT.

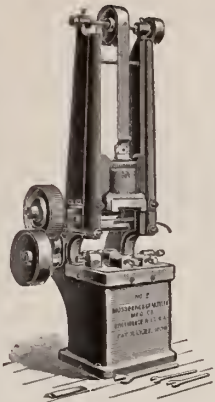

No. 5 Automatic Drop Press  
Made in 12 Sizes.

OUR DROP PRESSES embossed more gold and silver last season than all the drop presses of other makes combined; they are money makers. Perhaps they will enable you to do work that you've never yet been able to handle to your satisfaction or profit in a satisfactory and profitable manner.

SEND FOR DROP PRESS BOOK.

WE ALSO MANUFACTURE ALL KINDS OF

## JEWELERS' AND SILVERSMITHS' MACHINERY.

WESTERN OFFICE:  
Mercantile Bank Building,  
Cleveland, Ohio.

### MOSSBERG & GRANVILLE MFG. CO.,

NEW YORK, 126 Liberty St.

PROVIDENCE, R. I.

Philadelphia Bourse.

# "OMEGA" WATCHES.

NONE BETTER MADE. OVER 1,000,000 IN USE.

GOOD SELLERS EVERY DAY IN THE YEAR.



Pendant Set. 12, 14 and 16 Size.  
Made in Gun Metal, Silver, Gold-Filled  
and Solid Gold Cases.

Place your orders early in the year for these watches and avoid later on the embarrassment of delay that you experienced last season.

We will accept orders and deliver WHEN you wish them.

These watches are sold only to the legitimate trade.

No prices advertised in any journal.

Made in 00 size.  
" " 0 size.  
" " 12 size.  
" " 16 size.

Edmund E. Robert, 3 Maiden Lane, N. Y.;

Cross & Beguelin, 17 Maiden Lane, N. Y.,

SOLE SELLING AGENTS.

Send for Price-List.

**The Funeral of Elton I. Franklin.**

NORTH ATTLEBORO, Mass., Dec. 26.—The funeral of the late Elton I. Franklin took place on Saturday last, at his home



THE LATE ELTON I. FRANKLIN.

on High St. As it was the wish of his family, the Masons and Odd Fellows, among whom he was a leading spirit, refrained from attending *en masse*, but a large number of the members were present as personal friends. Many prominent men who were long associated with him in bus-

iness circles were also present. The flowers received were very numerous and Rev. Frank L. Masseck, of the Universalist church, a near friend of the deceased, officiated. The interment was at Mt. Hope cemetery, a plot of ground whose beautiful arrangement is the product of Mr. Franklin's personal interest.

The bearers were George K. Webster, Henry H. Curtis, of H. H. Curtis Co., Walter G. Clark, of W. G. Clark & Co., George W. Cheever, W. W. Sherman and E. E. King, all but the last being jewelers well known by the American trade. The factory of E. I. Franklin & Co. is to be continued in operation pending a settlement of the estate.

**J. H. Johnston's Carefulness Leads To Arrest of a Would-be Swindler.**

The shrewdness of J. H. Johnston, of J. H. Johnston & Son, wholesale jewelers, 18 John St., New York, was the means of putting a possible jewelry swindler behind the bars at Pittsburgh, Pa., last week. On the 21st of December Mr. Johnston received a letter on the stationery of Scott & Boylan's European hotel, Pittsburgh, Pa., of which the following is a copy:

J. H. JOHNSON & Co.,

Gentlemen: Enclos find my check for \$145.50 for 2 rings No. 5987 and No. 5677 in your catalogue. Please ship them to Mr. P. Cutler Cor. First Ave. and Smithfield St. Scotts Hotel, Pittsburgh, by Special Delivery So that he will get them by Saturday sure as I want them to arrive for Xmas size about medium for gentlemen for both Hoping this will be on hand by Saturday I am

Yours Truly,

PETER JAMISON.

With the letter was a check for \$145.50 signed with the name, Peter Jamison, and drawn on the Farmers' Deposit National Bank. Upon examination of the letter and the check Mr. Johnston was suspicious, and finally became convinced that the matter was not legitimate. He immediately communicated with the superintendent of police, A. H. Leslie, of Pittsburgh, telling him of his suspicion, and Wednesday received from him an answer telling that his information had borne fruit. According to this letter, Roger O'Mara, superintendent of the Bureau of Detectives of Pittsburgh, caused an investigation to be made, which resulted in the arrest of Edw. Anderson, alias Paul Cutler. The man was arrested as a suspicious person and was taken before Magistrate McKenna, who, after a hearing, committed him to the workhouse for a term of 30 days. It is believed that the so-called Jamison, Anderson or Cutler, whatever his name may be, also wrote to other jewelry houses, and it is, therefore, suggested that anyone who has received these communications or filled any orders for the party communicate with the Pittsburgh authorities at once.

**Facts Regarding the Export of Watches to Russia.**

WASHINGTON, D. C., Dec. 29.—Vice-Consul-General Hanauer writes from Frankfort, Nov. 18, 1899:

"During late years Warsaw has become the center of the watch trade in Russia. The dealings between foreign and Russian merchants are consummated there, these parties meeting once a year for the transaction of business in this line. At this time the Russian buyers from Moscow, Tula, Sarataw and Siberia give orders for the next 12 months and settle for past purchases. This trade is quite important. A few Geneva watchmaking firms sell over 1,000,000 rubles' worth here annually. Swiss watch manufacturers purpose now to establish an extensive depot of goods in their line at Warsaw, to increase the sales and monopolize the Russian watch market. They have applied to the Swiss Consul in Warsaw to furnish them detailed information. Our export associations would do well to obtain similar data from our consuls."

**Alleged Pennyweighter Arrested in Geo. E. Feagans's Store.**

JOLIET, Ill., Dec. 28.—The police captured a supposed diamond thief a few days ago at G. E. Feagans's jewelry store. He gave the name of L. Borne. He had entered the store a few minutes before and asked to see some diamond rings. A tray was shown him. It is claimed while looking at them Borne attempted to substitute a ring with an imitation setting in place of a genuine stone valued at about \$50. At the police station Borne was searched and a cheap ring with an imitation stone was found in his pockets.

G. J. Levytansky, Hallettsville, Tex., has sold his stock of jewelry, etc., to his brother, Haskell Levytansky, late of Lockhart, Tex.

**TO WATCH DEALERS:**

IT should interest you to know that all through the holiday rush our customers were protected in sales and profits ON WATCHES.

By early preparation we were enabled to respond immediately to their calls. Our business was phenomenal, yet

**NO ONE WAS SLIGHTED.**

You can readily appreciate the value of such service.

WE ARE THE LARGEST DISTRIBUTORS OF

**Dueber-Hampden Watches**

IN AMERICA.

"Send us your orders; we'll serve you well."



*John N. Sherwood & Co.*  
Watches. Chains. Diamonds. Jewelry.

No. 3 MAIDEN LANE, NEW YORK.

# THE DUEBER HERALD

THE ADVOCATE OF HONEST BUSINESS METHODS.  
\* DEVOTED TO THE RETAIL JEWELRY TRADE.\*

Vol. I

CANTON, OHIO, JANUARY, 1900.

No. 11.

## 1900.

1900.

\* \* \*

A new year!

\* \* \*

What changes will it bring? What new fields will it open? What fallacies will it explode? And what new lessons will it teach?

\* \* \*

Let us hope that it will explode one fallacy, at least. The fallacy of putting faith in the "explained," machine-made, ever-"improved" watch.

\* \* \*

Let us hope, further, that it will teach one lesson, at least. The lesson that the honest dealer must stand by the banner of the honest manufacturer for the sake of Honest Business.

\* \* \*

A Happy New Year.

## A PROMISE KEPT AND A PROMISE MADE.

A fitting fin-de-siecle climax to the many incomparable achievements of the Dueber-Hampden Works is the production of their new 12-size watches, illustrated in the last issue of **The Dueber Herald**.

In speaking of these watches it is difficult to refrain from eulogiums; difficult to refrain from praise that comes dangerously near the "sloping-over" point.

They are perfect time-keepers; perfect in every component part, perfectly put together, perfect in finish. They embody the most advanced ideas in watch-making, yet are wholly devoid of a single device that is experimental or of questionable merit. They are the closest-running, handsomest, most trustworthy time recorders ever produced.

In presenting this, their last contribution to the achievements of the century beginning with the figures 18, the Dueber-Hampden Works feel that a generous reward has come to them for their years of ceaseless labor, and they enter upon the new era with the promise that the success behind them will but serve as a spur for still greater enterprise and energy.

## YOURS TRULY, THE EDITOR.

The Dueber Herald trusts your Christmas trade has been satisfactory.

\* \* \*

Twenty-two weeks have passed since **The Dueber Herald** made its first bow to you, to tell you some of the things it knew about watches, movements and cases; to help you to larger watch sales.

\* \* \*

Naturally **The Herald** takes a deep interest in your affairs—your "watch affairs." Has it been of help to you?

\* \* \*

If it has, it will be of still greater help in 1900. If it hasn't, it'll begin to be.

\* \* \*

For such generous appreciation as it has received—and that has not been inconsiderable—**The Herald** extends its warmest thanks.

Bluefield, West Va.  
I am conductor on the N. & W. R. R.  
I have had a Hampden watch for three years. I would have no other watch while I can get the Hampden.  
GEO. S. LEWIS.

Let Columbia time  
Her Progress by the  
Dueber-Hampden Watch.

Slater, Mo.  
Have carried your 17-jewel watch since last July. It has given the best of satisfaction. I could not ask for anything better for railroad work.  
JOHN G. YOUNG, Conductor,  
C. & A. R. R.

#### How Diamond Robber Reilly Served Only a Short Term in Prison.

PHILADELPHIA, Pa., Dec. 28.—James Sullivan, one of the most notorious jewelry thieves in this country, pleaded guilty to-day in the Criminal Court to a charge of aiding and abetting James Reilly, alias "The Mouse," to escape from the Eastern Penitentiary. Reilly, as already published in THE CIRCULAR, was not slow to make good, or rather bad, use of his liberty, by robbing A. E. Sedle's jewelry store, Pittsburgh, several weeks ago.

Early in January, 1898, Sullivan and Reilly were arrested near 8th and Sansom Sts., together with Charles Hoyt and Wm. Devlin, all professional diamond robbers, on a charge of conspiracy to rob the jewelry stores of Geo. W. Russell, H. O.

Hurlburt & Sons and J. E. Caldwell & Co. They subsequently pleaded guilty and were sentenced to imprisonment. Upon entering the Eastern Penitentiary, Reilly and Sullivan gave each other's names and were known by the names they gave during their term of imprisonment. This exchange of names was agreed upon while they were riding to prison in the van. At the expiration of Sullivan's sentence Reilly was released, but this was not known to the authorities until about a month ago, when Reilly was arrested in Pittsburgh, charged with a diamond robbery. Sullivan was found in the Eastern Penitentiary serving out Reilly's sentence. Habeas corpus proceedings were brought and Sullivan was produced and indicted last Thursday. Sullivan was sentenced to 14 months.

#### Annual Meeting of the Manufacturing Jewelers' Board of Trade.

PROVIDENCE, R. I., Dec. 30.—The annual meeting of the Manufacturing Jewelers' Board of Trade was held to-day in the rooms of the organization, Wilcox building. The meeting was largely attended and considerable business of importance was transacted. The various reports, consisting of those of the treasurer, trustees and secretary, showed the Board to be in good financial condition and in a prosperous condition in every way. The following board of directors were elected for the ensuing year:

Dutee Wilcox, of D. Wilcox & Co.; W. R. Dutemple, of W. R. Dutemple & Co.; N. B. Barton, of the Ostby & Barton Co.; R. E. Budlong, of S. K. Merrill & Co.; George L. Vose, of the George L. Vose Mfg. Co.; H. Fletcher, of Fletcher, Burrows & Co.; H. G. Thresher, of the Waite, Thresher Co.; Charles E. Hancock, of Hancock, Becker & Co.; F. A. Ballou, of B. A. Ballou & Co.; W. P. Chapin, of the Chapin & Hollister Co.; J. P. Carpenter, of Ford & Carpenter; G. W. Parks, of Parks Bros. & Rogers; F. Esser, of Esser & Barry, all of Providence; E. S. Horton, of the Horton, Angell Co.; A. R. Crosby, of Smith & Crosby; E. A. Sweeney, of the W. H. Wilmarth Corporation, and C. A. Marsh, of C. A. Marsh & Co., Attleboro; G. H. Niles, of the Bugbee & Niles Co., and G. K. Webster, North Attleboro; W. S. Metcalf, of the Plainville Stock Co., Plainville, and D. S. Spaulding, Mansfield.

The annual report of the Board will soon be ready for distribution, it being now in the printers' hands.

#### Almost All the Cincinnati Jobbers Caught by the Failure of W. H. Bradshaw.

CINCINNATI, O., Dec. 30.—One of the reefs to mar the placid waters of prosperity to the Cincinnati jobbers was the failure of W. H. Bradshaw, Wooster, O. He bought last month from almost every jobber in town. He wanted to go into bankruptcy, but he was prevailed upon to see his creditors and effect some kind of settlement. His largest creditors are L. Gutman, \$750; Clemens Oskamp, \$500; Oskamp, Nolting & Co., \$400; Bene, Lindenberg & Co., \$450; Albert Bros., \$300; A. & J. Plaut, \$300; besides a number for less than \$100. He has 54 creditors and less than \$4,000 assets. His liabilities will amount to about \$10,000. He had, it seems, good commercial rating, yet when he was at Paris, Ill., four years ago, the business was conducted in the name of his wife, and when he sold out and removed to Wooster he left creditors, among them Henry Hahn & Co., Cincinnati, who afterwards refused to sell to him. He has been slow pay.

S. Lindenberg went to Wooster and reports that the entire assets are his store, which is worth \$3,000. When the store was sold out at Paris, Ill., he gave his wife a note for \$11,000, which she still holds. The son-in-law has offered to take a mortgage on the store and pay 20 per cent to all creditors for above \$75, and 50 per cent to all for below that amount. Jos. Noterman & Co. will come in for the 50

# WE

desire to thank our friends in the trade for the courtesies received from them during the year just closed, and to assure them that in the future as in the past our constant endeavor will be to serve them intelligently and faithfully, treating their interests as our own. We wish them all a prosperous New Year and will do all in our power to help them realize the wish.

## HAYDEN W. WHEELER & CO.,

TWO MAIDEN LANE, N. Y.

50 HOLBORN VIADUCT, LONDON.

per cent settlement, as they are creditors for less than \$75. The offer remains good until Jan. 2. Some of the creditors are disposed to reject the offer and are very wroth.

**Death of W. J. Porte.**

PICTON, Ont., Can., Dec. 29.—On the morning of Christmas day W. J. Porte, jeweler, one of the most prominent and influential citizens of this town, was found dead in his bed. Mr. Porte had been engaged in the jewelry business here for 44 years. He was born in Tagmon, Wexford county, Ireland, in 1831, and came to Canada in 1854. He was an energetic and public spirited man, taking a keen interest in municipal and political affairs, and at one time occupied the position of Mayor and other responsible posts.

He was an active and prominent member of several fraternal organizations and superintendent of the First Methodist Sunday School.

Mr. Porte had not been enjoying his usual health for some time, but was not seriously indisposed on Sunday evening when he retired. He was found quite lifeless at 7 o'clock A. M. The supposed cause of his sudden decease is heart failure. The funeral took place on the 28th, and was very largely attended. The deceased leaves a widow and four children, including James H. Porte, who has been associated with him for many years in his business, and Thomas J. Porte, who is engaged in the jewelry trade in Winnipeg, Man.

**Death of C. G. Potter.**

PITTSBURGH, Pa., Jan. 2.—The death of C. G. Potter, Penn Ave. and 28th St., on Dec. 29, at 4.30 o'clock A. M., was a great shock to his many friends. He had been ill but a very short time with typhoid fever, but the overwork during the holidays was too much for him. He had been in the jewelry business here for 15 years, and built a new building in 1895. His early knowledge was obtained in the store of W. D. Smith, New Castle. Mr. Potter is survived by a wife and child.

**Death of James McMillan.**

ST. CLAIRSVILLE, O., Dec. 22.—James McMillan, for many years a jeweler in this place, died to-day, aged 62 years. He was a member of the Fifteenth Regiment, O. V. I., in the civil war, and was a prisoner in Libby prison. He was unmarried.

Charles E. Goldsmith, formerly with J. K. Wiggins, Middletown, N. Y., has become a partner of L. H. Covert in the jewelry business, in Warwick, N. Y., taking charge of the optical branch of the business.

**HEADQUARTERS**

For....  
**Everything**

Used by  
**Jewelers.**



SEND  
FOR  
PRICE-  
LIST.

You can order from us any goods made by these 8 Giant factories and we can fill your order. What more can you want?

THIS  
WILL BE  
A  
GOOD  
WATCH  
YEAR.

**Cross & Beguelin, 17 Maiden Lane, N.Y.**

**EMPIRE COMBS. SIDE COMBS.**

GOLD AND JEWELLED ORNAMENTED.

SPECIALTIES IN ROMAN WORK.

**DAY, CLARK & Co.,**

MAKERS OF FINE JEWELRY,

23 MAIDEN LANE, N. Y.

**BONNER & CO.,**

Manufacturers of

FINE DIAMOND MOUNTINGS,

57 MAIDEN LANE, NEW YORK.



C OLD SHELL.

"Buy direct from the manufacturer and get all that is coming to you."

SEND FOR OUR "HOT CATALOGUE, CONTAINING COLD FACTS AND PRETTY PICTURES."

**CLARK & COOMBS,**

86 WEST EXCHANGE ST., PROVIDENCE, R. I.

WE ARE HEADQUARTERS FOR.....

**Gold Shell Rings...**



**THE MAUSER MFG. COMPANY.**  
SILVERSMITHS,

"Watch Our Ads." 15th St., bet. Broadway and Fifth Ave., New York.

### Movement to Revive the Rockford Watch Factory.

ROCKFORD, Ill., Dec. 28.—A movement is on foot backed by reliable capitalists, to again start the Rockford watch factory. The people interested in it are men of long experience in the local factory. The factory is still in good condition and could be put in operation on short notice.

### Death of John F. Jarvis, Jr.

MOUNT VERNON, N. Y., Dec. 30.—John F. Jarvis, Jr., a member of the jewelry firm of John F. Jarvis & Son, whose store is at 64 Fourth Ave., died to-day after a brief illness. The deceased was 42 years of age and was one of the most prominent jewelers of this town.

## No Doubt

can there be as to the best gold-filled watch case of the century. The best designs, the best quality, the best workmanship, the best guarantee are all combined in the Bell Gold-Filled Watch Cases.



Remember, any special design, emblem, monogram, portrait, etc., that your customer may desire can be engraved for the asking when you

**Buy of the Maker.**

**THE BELL WATCH  
CASE CO.,**

**CINCINNATI, OHIO.**

### Jewelry Manufacturers Aroused.

#### The Proposed Reciprocity Treaty with France a Serious Menace to Their Interests.

ATTLEBORO, Mass., Jan. 2.—The jewelers of the Attleboros are aroused against France. It was only this week that they learned that the reciprocity treaty which has been signed between the United States and the French Republic and which will or will not be ratified by this sitting of Congress, aims a serious blow at their industry. So little attention has been given to this proposed measure by the jewelers of the Attleboros that months have past with the sword hanging over their heads and they have been unaware of their danger. A personal letter received last week from a New York friend by Edward A. Sweeney, of the W. H. Wilmarth Co., and one of similar tenor received at the same time by Theron I. Smith, of T. I. Smith & Co., North Attleboro, disclosed the state of affairs. As brief a way as any to get at the substance of the matter is quoted as follows from matter given by the jewelers interested to one of the local papers in their district:

Chapters 448, 449, 450 and 459 of the Tariff Act, approved July 24, 1897, better known as "the Dingley Law," provides for a 35 per centum ad valorem on articles of amber, mother-of-pearl, shell and meerschmum. This new schedule would reduce that duty 15 per cent.

Chapter 434 is a hard slap at the makers of brooches. This provides for 60 per centum ad valorem on articles commonly known as jewelry, or parts thereof, finished or unfinished, not especially provided for in the act, including precious stones set, pearls set or strung, and cameos in frames. The new tariff would reduce this 5 per cent. A 5 per cent reduction is provided for in chapter 414 and this will hit Attleboro hard, as it deals entirely with buttons. The closing part of this chapter includes "all buttons not specially provided for and all collar or cuff buttons or studs." The present duty is 50 per centum ad valorem.

There is also a 5 per cent reduction provided in chapter 412 which deals with buckles, and this hits at the makers of buckles for sleeve elastics, ornamental belts and such.

A 10 per cent reduction is provided for in the matter of brushes; 10 per cent on penholders, and the same on all imitation jewelry. This latter part is dealt with in chapter 408 and includes beads, spangles and trimmings composed wholly or in part of glass or paste, gelatin, metal of other material. The present tariff is 60 per centum ad valorem.

After glancing at the above the manufacturing jewelers and the employes will see that if the new schedule is allowed to go into effect it will be very disastrous to the trade.

It is well to assume that articles mentioned above will be manufactured in England and Germany and then sent to this country via France in order that they may secure the advantages of this reduction. Under the old condition of affairs before the jewelers' tariff commission secured the classification, the French competition was the most dreaded. Some articles of merit were sent here and sold in this country at less than they could be manufactured for in Attleboro.

Of course this competition can be met, but only in one way, and that is by reducing the compensation of workmen.

When the matter had been realized by Mr. Sweeney and his associates the following letter was framed:

ATTLEBORO, Mass.

To Honorable George F. Hoar and Honorable Henry Cabot Lodge,

DEAR SIRS:—We notice from the published copy of the French reciprocal treaty signed between the United States and France last Summer and now awaiting the ratification of the United States Senate the treaty provides for a reduction of the duties of:

- 10 per cent for imitation jewelry;
- 5 per cent for jewelry;
- 15 per cent for articles of amber, ivory or pearl;
- 10 per cent for buckles;
- 10 per cent for penholders.

If such a reduction is permitted it will seriously affect the trade of Attleboro, North Attleboro, Taunton and Providence manufacturers, and we earnestly beg that you will use your best efforts to prevent the ratification of this treaty until the clauses containing the above mentioned concessions (or any other clauses having any bearing on the jewelry or any kindred trades) are eliminated from the same. The manufacturers of this district, after years of hard struggling, are just beginning to reap the fruits of a prosperity guaranteed them by the Republican party, and it would be suicidal to permit the slightest infringement upon that prosperity by any foreign nation. We, the manufacturers upon whose prosperity rests the prosperity of thousands of employes, and the welfare of our towns and cities, pray that we may be protected in that prosperity and not be placed again in competition with the pauper labor of Europe.

To the letter were signed the names of the following business houses:

The W. H. Wilmarth Co., the D. F. Briggs Co., McRae & Keeler, Charles M. Robbins, Dunbar, Leach & Garner Co., C. A. Marsh & Co., Daggett & Clap, Torrey Jewelry Co., MacDonald & Culver, Richards, Hill & Co., Sykes & Strandberg, Rhodes Bros., Dolan & Co., E. D. Gilmore & Co., G. A. Dean & Co., F. H. Sadler & Co., E. A. Fargo & Co., O. W. Hawkins & Co., Regnell, Bigney & Co., Smith & Crosby, Simms & Co., D. E. Makepeace, Grover, Son & Co., P. J. Cummings & Co., S. O. Bigney & Co., Bates & Bacon, J. W. Luther & Co., C. H. Allen & Co., Marble, Smith & Forrester, J. T. Inman & Co., D. A. White & Co., J. M. Fisher & Co., F. W. Weaver & Co., Attleboro Mfg. Co., S. M. Einstein & Co., Allen, Smith & Thurston, George L. Brown & Co., Horton-Angell Co., Bliss Bros., R. F. Simmons & Co., Watson & Newell Co., The James E. Blake Co., A. Bushee & Co., J. C. Cummings & Co., F. M. Ellis & Co., Daggett Jewelry Co.

Only one way to fight the threatening measure stood open, and to that all naturally turned. The Republican Club of Attleboro, the Company C Association, contained among its members the old committee which went down to Washington when the Dingley tariff bill was being formulated and by persistent effort secured the legislation which has given them the prosperity this group of towns now enjoys. The committee responded to the unworried invitation to take up the sword again. Sidney O. Bigney, of S. O. Bigney & Co., called a meeting for Monday evening, Jan. 1, in the parlors of the Association's club house. It was to be a public meeting. The old committee consisted of Mr. Bigney, G. E. Luther, Providence, since deceased; William R. Dutemple, of W. R. Dutemple & Co., Providence; Henry A. Thresher, of the Waite, Thresher Co., Providence, now Mayor of Central Falls, R. I.; Harry P. Kent, of F. W. Weaver & Co.; Everett S. Horton, of the Horton, Angell Co., and Albert A. Bushee, of A. Bushee & Co.

The meeting held last night by the tariff committee of Company C Association and others interested was a brief one. So many conferences had been held and so much published that there was little left to say. It was decided after some discussion that the representatives in Congress from this section are competent to handle the matter without the help of representatives of the trade at their elbow. Acting secretary Frank W. Weaver, head of F. W. Weaver & Co., was instructed to write a lengthy letter outlining the position of the jewelers of the Attleboros and to send it to Congressmen Lodge and Lovering, of Massachusetts, and Aldrich and Bull, of Rhode Island, and ask their good offices in opposing the ratification of the treaty until the objectionable articles are expunged.

**Decision Regarding the Acceptance of a Check in Full Settlement.**

CHICAGO, Ill., Dec. 29.—The Supreme Court of Illinois has just decided an interesting and important question of commercial law in the case of Smith & Crosby, Attleboro, Mass., against Lapp & Flershem, this city. Smith & Crosby had a claim against Lapp & Flershem for \$2,246.29 and demanded payment. Lapp & Flershem contended that the account was not due and also that they had an offset of \$50 for advertising in their catalogue Smith & Crosby's goods and business. To adjust the matter they wrote Smith & Crosby on May 7, 1898, giving their understanding of the account, and inclosed a check for \$500 and three notes, payable in four, five and six months after date, respectively, which aggregated in amount the claim of Smith & Crosby, less the \$50.

On May 12, 1898, Smith & Crosby replied, alleging the account was past due and saying they would not allow the deduction of \$50. They kept the check, but sent the notes to their attorney in Chicago with directions to tender them back. The notes were tendered to Flower, Smith & Musgrave, attorneys for Lapp & Flershem, who declined to receive the notes unless the check was also returned, but Smith & Crosby refused to return the check, placed it to the credit of Lapp & Flershem, and then brought suit for the balance of the account. On the trial the attorney for Smith & Crosby conceded the claim for \$50 by Lapp & Flershem, and the Court instructed the jury to bring in a verdict for Smith & Crosby for the total amount of the account, less the \$500 check and the \$50; and judgment was entered for the difference. This judgment was appealed by Lapp & Flershem to the Appellate Court of Illinois for the First District, where the judgment was affirmed. It was then taken on appeal to the Supreme Court of Illinois, which has just reversed the judgment of both the lower courts.

The Supreme Court holds that there having been an honest dispute as to the amount of the account and its maturity, and Lapp & Flershem having sent a check and three notes in adjustment of the account, according to their understanding of it, Smith & Crosby were bound to accept the notes if they accepted the check, and having accepted the check and used it, they were not entitled to sue for the balance of the account. This decision is based upon the previous ruling of the Supreme Court of Illinois, on which the attorneys for Lapp & Flershem relied, *Ostrander vs. Scott*, 161, 111, 339, which held that where a merchant sends a check in payment of a disputed account, with a statement that it is in full of account, if the creditor accepts it, it is satisfaction of the account and he cannot simply credit it and sue for the balance. Smith & Crosby are not only liable for the costs of this litigation, but are now in the position of being obliged to request Lapp & Flershem to pay or to return to them the notes which they have twice refused to receive.

In a fire in Rock Creek, O., Christmas day, Walter St. John's jewelry store was among the places affected.

WE desire to call the attention of those buying early this season to our large and complete line of guard chains suitable for the lorgnette, watch, fan, muff, purse, or for use as an eye-glass chain, and especially to the many new patterns of chains and slides we are showing. We have borne in mind the tendency toward heavier chains, and are showing some patterns which at this date we believe cannot be duplicated elsewhere.

**B. A. BALLOU & CO.,**  
Providence, R. I.



**DESIGNS, QUALITY, PRICES,**  
**Small Profits and Large Sales**  
combined have created the  
great demand for the . . .  
**10k. and 14k. Gold Jewelry**  
MANUFACTURED BY  
**HANCOCK, BECKER & CO.,**  
Providence, R. I.  
**SOLD THROUGH JOBBERS ONLY.**

**NEW LINES.**

**NEW FIRM.**

**SEAMLESS-SOLID-GOLD-FILLED**  
**.... RINGS ....**

**THESE ARE A SPECIALTY WHICH IS MEETING WITH GREAT SUCCESS.**

New York Representative :  
**W. M. BOOTH,**  
No. 3 Union Square.

**CHASE MFG. CO.,**  
40 Clifford St., PROVIDENCE, R. I.

Western Representative :  
**I. S. RICHTER,**  
Chicago—Stewart Bldg.

Manufacturers of Link Buttons, Shirt-Waist Sets, Locketts and Charms, Beauty Pins, Tie Holders, Chain Pins, in Rolled and Electro Plate.

## Our Traveling Representatives



Traveling representatives may consider these columns open for the publication of any news or items of interest regarding themselves or their confreres.

John Gardner, familiarly called "Farmer John," has closed his contract with G. W. Marquardt & Sons, Chicago, and during 1900 will represent Baldwin, Miller & Co., Indianapolis, Ind., in Indiana, Illinois and Ohio.

Travelers in Pittsburgh, Pa., during the past week were: A. H. Oakley, Thornton Bros. and Walter E. Hayward; J. B. Richardson, Burns Mfg. Co.; Mr. Rounds, Hancock, Becker & Co.; F. B. Brigham, Cheever, Tweedy & Co.; Geo. L. Paine, E. I. Franklin & Co.; H. B. Richardson, G. A. Dean & Co.; Mr. Tappan, The D. F. Briggs Co.; C. P. Elliot, Maintien Bros. & Elliot; H. E. Cobb, Daggett & Clap Co.; Wm. W. Middlebrook, B. A. Ballou & Co.; C. T. Barbour, Plainville Stock Co.; Harry B. Kennion, Parks Bros. & Rogers; Milton S. Rodenberg, Rodenberg & Dunn; L. B. Jones, C. A. Marsh & Co.; Mr. Steere, Geo. L. Brown & Co.; Geo. H. Remington, Waite, Mathewson & Co., and Mr. Cummings, J. F. Sturdy's Sons.

Traveling men were very few and far between last week in St. Louis, Mo. Frank R. Horton, of Carter, Hastings & Howe, spent Christmas there; another representative was Wm. F. Maintien, of Maintien Bros. & Elliot.

Some of the "early birds" from the east who reached Indianapolis, Ind., about the time the New Year arrived were: Gus Rodenberg, S. & B. Lederer Co.; Geo. L. Paine, E. I. Franklin & Co.; Ernest Block, Louis Stern & Co.; Chas. Marsh,

C. A. Marsh & Co.; H. E. Cobb, Daggett & Clap Co.; L. T. Field, W. G. Clark & Co.; Wm. A. Wightman, H. D. Merritt & Co.; C. P. Elliot, Maintien Bros. & Elliot.

Eastern men were in evidence in Cincinnati, O., last week in swarms. They took good orders. One man claimed to have sold 200 dozen hearts to one firm. Among those seen Saturday were: H. E. Sweet, R. F. Simmons & Co.; C. Reed, J. C. Cummings & Co.; Mr. Steere, George L. Brown & Co.; W. T. Sherman, S. K. Merrill & Co.; Mr. Elliot, of Maintien Bros. & Elliot; Herbert Bliss, Bliss Bros.; Mr. Cox, S. O. Bigney & Co.; Mr. Pierce, T. I. Smith & Co.; John Marsh, C. A. Marsh & Co.; Mr. Shafer, Regnell, Bigney & Co.; Mr. Dunn, Rodenberg & Dunn; Mr. Millimin, Wm. W. Hayden Co.; Mr. Tappan, D. F. Briggs Co.; C. H. Allen, C. H. Allen & Co.; Mr. Lucas, A. H. Bliss & Co.; W. A. Wightman, H. D. Merritt & Co.; Mr. Vaslett, Fletcher, Burrows & Co.; Mr. White, A. Bushee & Co.; Mr. Metcalf, R. Blackinton & Co.; Mr. Remington, Carter, Ovarnstorm & Remington; Mr. Fellows, McRae & Keeler; E. Block, Louis Stern & Co.; H. Crook, Geo. L. Vose Mfg. Co.; Max Potter, J. M. Fisher & Co.; Mr. Major, of W. H. Luther & Son; D. N. Jacoby, Providence Stock Co.; J. B. Richardson, Burns Mfg. Co.; E. P. Tiffany, F. H. Sadler & Co.; H. E. Cobb, Daggett & Clap Co.; Mr. Schwarzkopf, Schwarzkopf & Solinger. Other houses represented were: Schofield, Battey & Co.; S. & B. Lederer Co.; J. Friedman; Torrey Jewelry Co.; J. M. Fraser & Co.; Dolan & Co.; Armstrong Braiding Co.; Marden & Kettley. Several changes among the eastern travelers were noted.

Chapman & Barden, Plainville, Mass., have opened an office in Chicago, at 126 State St., room 1017, where their representative, H. P. Cutter, will be pleased to show the firm's line to Chicago buyers and those visiting the city. Their New York office is now at 54 Maiden Lane, room 504. W. F. McGown, who represents the firm there, will also call on the western trade outside of Chicago.

## Eastern Travelers Feast.

Annual Meeting and Banquet of the Jewelry Travelers' Association of New England.



BOSTON, Mass., Dec. 28.—When the days begin to lengthen, and the cold begins to strengthen, and the Christmas rush is left behind, then the jolly jewelry drummer turns mid-Winter into Summer, and at his own expense is regally "dined." It all happened at the Quincy House on this

date, and a more festive gathering of the pioneers of trade is seldom witnessed in the Hub.

Shortly after 6 o'clock P. M. the members of the Jewelry Travelers' Association of New England began to fill up the parlors allotted to them for their business session, which was to precede the banquet, for is not every traveling man's motto "Business before pleasure"?

President Fred R. Hollister presided at the brief session, and secretary and treasurer E. A. Bigelow read the records of the last meeting and receipted for dues paid in by members. A full treasury and an excellent condition of the association socially were reported. There were present about 75 participants, including the members and invited guests. Harry F. Hayes, F. A. Balcom and Col. John L. Shepherd were constituted a nominating committee to bring in a list of officers, and submitted the following "slate," the nominees being unanimously elected:

**WALTHAM WATCHES**  
ARE CARRIED ALL OVER THE WORLD



President, Frank E. Buffum; vice-president, F. H. Elliott; secretary and treasurer, W. Emery Clement; executive committee—William C. Wales, Ben Levy, Henry A. Arnold, George L. Swett, Edwin H. Litch; auditing committee—Gus A. Felber, Frank F. Place, Major Herbert S. Tanner.

A vote of thanks was tendered to retiring secretary E. A. Bigelow for his devotion to the society's interests during his incumbency of the office. Mr. Bigelow declined a renomination.

In the dining hall a fine menu was thoroughly enjoyed by the assemblage, and toasts to President Hollister, President-Elect Buffum and absent friends were proposed, with a happy New Year sentiment as the finale from the chair, who referred briefly to the past year's prosperity and wished all a good business year for the closing one of the century.

After cigars were lighted the hall was cleared of the banquet tables in a twinkling and opportunity was afforded for the introduction of an exceedingly entertaining vaudeville performance. The company were favored also with vocal and instrumental solos by Messrs. Nichols, Fox and Hinds, the last a talented member of the association, with a very pleasing baritone voice. Col. John L. Shepherd responded to a call for "a drummer's yarn."



Much credit was deservedly accorded the executive committee and Secretary Bigelow, as well as president "Jack" Hollister, as he is familiarly known to the boys, for their efforts to insure the success of this 10th annual midwinter banquet of the association. The executive board comprised William C. Wales, F. H. Elliott, W. E. Clement, George L. Swett and Walter B. Snow. Around the tables were:

Fred R. Hollister, Frank E. Buffum, Edward A. Bigelow, W. Emery Clement, F. H. Elliott, Walter B. Snow, C. M. Ballard, Fred O. Fuller, George L. Swett, John L. Shepherd, Willis A. Cates, Ben. Levy, Gus A. Felber, Herbert S. Tanner, John B. Humphrey, Clinton Sproat, Wm. L. Russell, E. L. Drake, G. S. Melville, A. M. Hinds, George F. Andrews, W. F. Newhall, Daniel Curran, Harry L. McGachie, C. A. Parker, J. Moss, A. C. Sylvester, H. E. Pitcher, H. W. Tuttle, C. T. Derry, F. E. Chick, F. Gendren, H. L. Reynolds, George E. Morrill, George O. Rice, F. S. Scales, F. A. Balcom, B. O. Armour, George Goddard, F. E. Pratt, F. H. Bliss, F. A. Worth, F. T. Holbrook, Guy L. Millett, Chas. M. Brown, Edward P. Tirrell, John A. Abel, John Kelso, Geo. Morrell, A. E. Fiske, A. Fred Goudey, H. N. Lockwood, J. H. Conner, E. S. Roberts, W. S. Lee, H. F. Palmer, D. Dunbar, Jr., representatives of the press and other guests.

**W. B. Knapp at Length Succumbs to the Inevitable.**

BOSTON, Mass., Jan. 2.—W. B. Knapp, retail jeweler in gems, 61 Temple Place, until Friday occupying part of the store of Derry & Bigelow in that location, has removed his stock and fixtures from the premises and assigned to his attorney, C. Eldredge, of this city. His liabilities are placed at about \$40,000, and his assets in the vicinity of \$15,000. Mr. Knapp was formerly on Boylston St. near the corner of Tremont, and compromised with his creditors then, shortly after the subway explosion, which injured his store and stock and hampered him in business.

**Death of August Jarecki.**

ERIE, Pa., Dec. 28.—August Jarecki, one of Erie's oldest and most prominent men, died early this morning at his home, 622 State St. Mr. Jarecki had been ill for over a month with grip and stomach complications. He was over 76 years of age.

Mr. Jarecki was the first of that family to settle in Erie. He came here direct from Posen, Prussia, in the year 1848. The following year his betrothed came here from Germany and the young couple were married. In the year 1857 Mr. Jarecki started up business for himself at 622 State St., in the block that bears his name. Since then till the present time he has been engaged in the jewelry business at the same place. He was one of the founders of St.

Paul's Evangelical Church, over 50 years ago, and had been prominently connected with the church ever since. In business affairs, as in his private life, he was honorable and trustworthy.

Four brothers are left: Charles, Fred and Herman Jarecki, of this city, and Gustave Jarecki, now in Europe. He leaves three sons, Ottomar and Amiel Jarecki, who reside in Erie, and Dr. Edwin Jarecki, of Philadelphia. Two daughters are also left to mourn his death, Mrs. Ed. Hoffman and Mrs. Chas. A. Curtze.

**Death of Joseph Dueber.**

CANTON, O., Jan. 2.—The death occurred Sunday of Joseph Dueber, son of John C. Dueber.

*1852-1900.*

*Forty-eight years* of business life,

*An unblemished reputation*

for products equal to the best,

*One standard—*

Sterling, 925-1000 fine;

*Experienced representatives,*

*A specialty of Tableware,*

salable the whole year through, are facts worthy your consideration in placing your orders for 1900.

*J. B. & S. M. Knowles Co.*



TRADE-MARK.  
Established 1852.  
Incorporated 1891.

*Silversmiths,*

*91 Sabin St., Providence, R.I.*

**Death of Edward Todd.**

Edward Todd, the old and well known manufacturer of gold pens, who for many years had been at the head of Edward Todd & Co., died suddenly Sunday at his resi-



THE LATE EDWARD TODD.

dence, 66 Madison Ave., New York. Death was due to cerebral hemorrhage.

Mr. Todd was born at Bristol, Conn., Sept. 18, 1826, and was the son of Jonah H. Todd, of that place. His business career commenced at an early age when he came to New York and first associated himself with Bard Bros., gold pen and pencil case manufacturers. When that firm retired from business the deceased, with W. S. Smith, continued under the style of Smith & Todd, which firm subsequently became Mabie, Todd & Co. From this firm Mr. Todd retired in 1870, and two years later formed the firm of Edward Todd & Co., and manufactured lines similar to those he had formerly been engaged in. From 1872 until two years ago Mr. Todd remained the active head of his firm. In 1897, owing to ill health, he retired from business life. Besides his connection with the pen, pencil case and jewelry trades, Mr. Todd was associated with a number of other business enterprises. Among others he was a director in the Brooklyn Life Insurance Co., of Brooklyn, and in the Bank of North America. He was also prominent in religious and charitable work and was a trustee in the Church Charity Foundation Society and also in the Brooklyn Homeopathic Hospital, as well as for many years a vestryman in the Holy Trinity Church, of Brooklyn.

The deceased leaves four children, consisting of two sons and two married daughters. He is succeeded in business by his son, Edward Todd, Jr., from whose residence, at 369 Manhattan Ave., the funeral took place yesterday at 10 o'clock A. M.

Partnership liability as to third parties may be established by proof that the party sought to be charged as a partner held himself out as such or permitted others to do so.

**Providence.**

Max Deutz has taken the shop at 21 Fountain St., formerly occupied by Bars-tow & Williams.

Joseph Rosenberg has been admitted into the firm of S. K. Grover & Co., for whom he has been a traveling salesman.

S. O. Bigney & Co. have completed the removal of their plant to their new building in Attleboro, and within a very short time T. E. Bennett & Co. will be installed in the shops which the Bigney firm have vacated.

F. P. Hall & Co. have succeeded A. H. Thurber & Co., 54 Page St., and will engage in the manufacture of jewelry. It is understood that the creditors of A. H. Thurber & Co. will be paid at the rate of about 40 per cent.

Articles of incorporation of the Ludwig, Stern Co. were filed at the office of the Secretary of State last Saturday. The company are formed to manufacture jewelry and novelties of various kinds. The incorporators are Henry Ludwig, Julius Stern and Phillip Stern. The corporation are located in this city, and the capital stock is \$24,000.

In the Sixth District Court, Civil Division, the Hunt Jewelry Co. Thursday brought suit against William Corbett for alleged trover and conversion of a diamond ring. On motion judgment was for the plaintiffs for \$88 and costs. The same company brought suit against Annie Nixon for alleged trover and conversion of a watch. Decision was for the defendant for costs by non-suit of the plaintiffs.

A fire Thursday morning in the building opposite the Metcalf building, Pine St., did some little damage to the property of the engravers and enamellers who have quarters there. E. L. Arnold, enameler, estimated his loss at about \$350, while George Van Der Burgh, hub and die cutter, lost about \$150. The loss of Mr. Arnold's property was covered by insurance, but Mr. Van Der Burgh was not so fortunate. Several other tenants suffered from the smoke.

A meeting of the Silversmiths' Benefit Association, connected with the Gorham Mfg. Co., was held in the Casino building at the company's plant, at Elmwood, Saturday afternoon. This is the smallest as it is the youngest beneficial organization at the works, but there were 253 members in attendance at the meeting. The receipts for the past year amounted to \$3,075.29, and the sick benefits to \$1,927.19. A dividend of \$4.60 per member was paid out. The following officers were elected for the ensuing year: President, Arthur J. Augihy; vice-president, Christopher Webster; secretary, George Robinson; treasurer, Henry C. Bushnell; auditors, Charles E. Barrett and Ellis T. Tompkins; trustees, William Hughes, Rudolph Gages, Ambrose E. Peck; physician, Andrew E. Matthews.

**The Attleboros.**

J. T. Inman & Co. will dissolve partnership this week.

Fontneau & Engley will remove their plant to the Robinson building, No. 1, according to the local press.

Arthur A. Macdonald has moved into the shop just vacated by J. B. Ellis, and opened an engraving establishment.

David E. Makepeace, Attleboro, was raised to high office last week in the local branch of the Odd Fellows. J. Perry Carpenter, of Ford & Carpenter, Providence, was similarly honored by the Attleboro Knights of Pythias.

Edwin Burtonwood, who withdrew last week from Burtonwood & Wheelock, does not propose to engage in business immediately on his own account, though this has been reported. He has been offered a position with a local manufacturing house, which he will accept.

Thomas Giguere and Felix Dion have organized the Standard Swivel Co. and taken the quarters in the Robinson building, Union St., Attleboro, vacated by Richards, Hill & Co. They have put in a mechanical equipment and will make a new device in the shape of a swivel.

The jewelers of this section have been invited by the Treasury Department to furnish some data about the quantity of gold coins melted up for use in the manufacture of jewelry. This is part of a search being made by that department to discover into what channels over \$300,000,000 in gold has disappeared in the past 20 years.

The item in these columns last week to the effect that E. Ira Richards, North Attleboro, would carry the grip for the Horton, Angell Co. was an error, to correct which the correspondent made an attempt when it was too late. The information was from one whose position would give weight to the statement; hence the unintentional mistake.

Houses whose representatives called on jewelers in the Attleboros the past week and placed large orders for the Spring trade were: Hainsfurther Bros., Petersburg, Ill.; Lehman & Prissman, Baltimore, Md.; S. A. Schreiber, Baltimore; David Marx Sons, St. Paul, Minn.; J. & B. C. Silver, Montreal; Mr. Bemis, Toronto; Mr. Jacobs, Chicago, and J. A. Pitts, Montreal.

Tuesday, Dec. 19, S. O. Bigney & Co. were a Providence jewelry manufacturing house with a big plant and 200 hands. Dec. 20 they began to remove to Attleboro, and the Tuesday following were in full operation in the new shop there. The first day after Christmas they shipped their first goods from their Attleboro address. The other tenants of the building are all in and in operation also.

J. F. Sturdy's Sons suffered from a robbery last November and never found it out until last week. It seems one Ernest Dean, well known to the Massachusetts police, was arrested in Natick last week. He had tried to pay for a drink in a saloon by handing a watch chain to the barkeeper. The man was arrested and deputy sheriff S. R. Briggs, of Attleboro, notified. The Natick police thought of the goods as certainly stolen and sent for Mr. Briggs, because he was an officer in a leading jewelry town. Briggs recognized Dean, and the latter at once made confession. He said that in November he entered the Sturdy factory and stole the chain and a \$25 pair of field glasses. The Sturdys had never known they were thus robbed, but on looking in the box where they had supposed the chain securely locked, found it empty. Dean is held in \$500 for trial.

# The "Cambridge."

We are opening the New Century with the introduction of another pattern of spoons and forks that we expect will not only be as popular with our customers as have been our recent productions in that line, i. e., "Lancaster," "Strasbourg," "Queen's," etc., but that we believe will exceed in sales any of these predecessors.

One object we have had in view, both in the case of the "Cambridge" and the "Queen's," is permanently establishing them in our customers' stocks. They have been especially designed as good-wearing patterns to the eye; therefore, the Jeweler finds it of more than usual interest, as once in stock he will find his trade in these standard patterns a constantly increasing one, while his patrons will appreciate the effort to place before them patterns of sufficiently good design and manufacture to insure them a permanent place among their family silver.

Many features of the "Cambridge" have been carefully studied to produce the best possible results as to strength, harmony of the whole design, bowls and blades, as well as handles. Every advantage of our new and original methods of bowl making has been utilized in this pattern, so that there are no sharp edges, no stamped ornaments with hollow backs, so generally used by makers of cheaper silver wares, but a strong, highly finished article of spoon manufacture characteristic of the productions of the Gorham Company in this line. Most of the Jewelers have now learned that they can supply their customers with Gorham wares at no higher prices than those of ordinary makers, and they find that their customers are very appreciative of being able to have silver wares of the same trademark and the same manufacture that they have been accustomed to look for; this preference often coming to them from the use of their mothers' silver. For these reasons Gorham Silver Wares and Gorham Spoon and Fork patterns have become the leading feature among the finer class of Jewelry Trade. Another advantage: they are always found in Jewelers' stocks; never elsewhere, such as Dry Goods stores, etc. The "Cambridge" promises to be a great Spring pattern. There is some PRESTIGE in having it among the first.



## Gorham Mfg. Co.,

...SILVERSMITHS...

Broadway and  
19th Street,      New York City.

BRANCHES:

NEW YORK:  
21 & 23 Maiden Lane.

CHICAGO:  
131-137 Wabash Avenue.

SAN FRANCISCO:  
118-120 Sutter Street.

WORKS: PROVIDENCE, R. I., AND NEW YORK CITY.

## Philadelphia.

### THE HOLIDAY TRADE.

The past week showed a most welcome slowing down of the killing pace necessitated, during the holiday rush, to keep the mercantile establishments ahead of the avalanche of trade. On every hand were heard reports that the holiday trade throughout the city and suburbs had assumed phenomenal proportions and was a fitting climax to a year of exceptional commercial activity. Local jewelers were confronted with a famine of watch movements. They were totally unable to meet the demand and several big houses were forced to buy watches from competitors at retail prices to fill their orders.

The Horological Society of Philadelphia will meet Thursday to elect officers for 1900.

Jacob Muhr, of H. Muhr's Sons, was last week elected a director of the Association of Jewish Immigrants.

Herbert Holland, manufacturer of watch cases, 2221 Harlan St., was married last week to Sadie B. Rapp, of 2417 Stewart St.

A small fire, caused by an overheated stove, did considerable damage Thursday to the jewelry store of W. D. Saunders, 713 South St.

James Barry, Jr., secretary of the Jewelers' Club, is confined to his bed at his home, 1312 Fairmount Ave., and is threatened with pneumonia.

The Merchants' and Salesmen's Association held their 25th annual meeting Thursday, in Odd Fellows' Temple, and elected officers for the ensuing year.

L. O. Waller, a popular young jeweler of Smyrna, Del., will soon graduate from the Pennsylvania Dental College and will

then sell his store in Smyrna and locate here.

On Jan. 6 the Philadelphia members of the Jewelers' Club will go to New York as the guests of the New York contingent, and will be wined and dined in a royal fashion.

The contract has been given for the repair of the fire damages at the optical establishment of Bonschur & Holmes, 1533 Chestnut St. The estimated cost is about \$6,500.

The contract for the badges to be worn by delegates to the Republican National Convention in this city, June next, has been awarded to Jeremiah H. Shaw, 1326 Arch St.

Mrs. Martha Sawyer, widow of Robert Sawyer, formerly a well known optician in this city, died at the residence of her daughter, Mrs. Mary E. Powell, Sunday, in her 93d year.

The proceedings of the meeting of the creditors of the bankrupt firm of B. F. Williams Co., indebtedness incurred under the firm name of D. F. Conover & Co., have not yet been made public.

A special meeting of the Philadelphia Jewelers' Club has been called for Tuesday evening, Jan. 9, to elect officers for 1900. A president, vice-president, secretary and treasurer and five directors will be elected.

Burtis H. Limerick, foreman of Bailey, Banks & Biddle Co.'s jewelry repair department, while riding on the river drive in Fairmount Park, Christmas day, was dangerously injured by being thrown from

his horse. Mr. Limerick, who is an expert equestrian, left his home about 3 o'clock in order to provoke a healthy appetite for dinner. The animal he rode was a spirited one. When near Girard Ave. bridge a train rushed across the Pennsylvania Railroad bridge and frightened the horse. It started on a wild gallop down the drive. Near the lighthouse Mr. Limerick lost his stirrup, and a sudden side jump of the horse threw him from his saddle with great force. He was subsequently found in an unconscious condition and bleeding profusely, and was sent to the German Hospital. There it was found he was suffering from concussion of the brain. Unless unforeseen complications ensue Mr. Limerick will recover.

## Boston.

Ben Levy will be with the house of E. A. Cowan this year, succeeding George Garland as head inside salesman. Mr. Garland will travel hereafter for the concern.

Henry A. Arnold was operated on for appendicitis Friday. Mr. Arnold is one of D. C. Percival & Co.'s best known inside salesmen, and there are many friends who wished him a speedy recovery.

National Supply Co., of Boston, have incorporated for dealing in wearing apparel, dry goods, jewelry, carpets, etc. Capital, \$10,000. Incorporators: J. Brodie, L. A. Cates, W. J. Daly.

E. P. Cruikshank has purchased an interest in the jewelry business of J. N. Nelson, Buffalo, Minn., and the new firm will be known as J. N. Nelson & Co.

# Opinions Differ

As to whether the NEW CENTURY began last Monday or not. Whichever opinion you hold, this is a good time to decide

**WHICH** of all the Watch Houses can, and will, give you the best service for the year 1900.

If **YOUR OPINION** and ours the same, the decision quickly reached.

Our **INTENTIONS** the best, and our **ATTENTION** to your wants shall be both careful and prompt.

**C. G. ALFORD & CO.,**

January 3, 1900.

195 Broadway, N. Y.

**Imports and Exports of November, 1899, and the Preceding 11 Months.**

WASHINGTON, D. C., Dec. 29.—The summary statement of imports and exports for the month ended Nov. 30, 1899, and the

partment by August Pol, through his attorneys, for the free entry, as household effects, under the provisions of paragraph 504 of the present Tariff act, of 12 sets of silver ware and one golden seal ring,

IMPORTS OF MERCHANDISE.

ARTICLES.	NOVEMBER.		ELEVEN MONTHS ENDING NOV. 30.	
	1898.	1899.	1898.	1899.
	Value. Dollars.	Value. Dollars.	Value. Dollars.	Value. Dollars.
<b>CLOCKS AND WATCHES, AND PARTS OF:</b>				
Clocks and parts of.....dut..	31,492	37,287	238,729	299,432
Watches, watch materials and movements.....dut..	116,571	156,337	795,939	1,087,177
<b>JEWELRY, MANUFACTURES OF GOLD AND SILVER, AND PRECIOUS STONES:</b>				
Diamonds, uncut, including miner's, etc., not set, free .....	394,030	209,433	2,245,392	4,626,105
Diamonds, cut, but not set.....dut..	256,456	636,001	5,174,695	8,628,279
Other precious stones, rough or uncut.....free..	2,276	8,110	27,114	56,432
Other precious stones, cut, but not set.....dut..	126,872	233,246	1,565,254	2,447,855
Jewelry, and manufactures of gold and silver.....dut..	180,486	238,063	1,868,772	4,249,891
<b>Total.....</b>	<b>960,120</b>	<b>1,324,864</b>	<b>10,881,227</b>	<b>20,008,562</b>
<b>PRECIOUS STONES, ETC. (free), imported from—</b>				
United Kingdom .....	265,931	56,102	1,085,984	3,606,094
France .....	.....	202	54,428	19,159
Netherlands .....	129,717	159,979	1,108,845	1,046,296
Other Europe .....	443	223	15,132	8,137
Brazil .....	.....	1,039	20	1,039
Other countries .....	215	4	7,097	1,819
<b>Total.....</b>	<b>396,306</b>	<b>217,549</b>	<b>2,272,506</b>	<b>4,682,537</b>
<b>JEWELRY, AND OTHER PRECIOUS STONES, ETC. (dutiable), imported from—</b>				
United Kingdom .....	59,405	404,409	2,363,066	4,767,250
France .....	266,719	383,168	2,972,183	4,844,013
Germany .....	68,994	73,420	645,487	903,073
Netherlands .....	128,878	160,542	1,941,549	3,817,016
Other Europe .....	41,900	83,384	654,720	961,058
British North America .....	49	826	2,137	7,430
Mexico .....	348	1,289	4,845	18,335
East Indies .....	382	.....	10,176	984
Other countries .....	139	277	14,258	6,866
<b>Total.....</b>	<b>563,814</b>	<b>1,107,315</b>	<b>8,608,721</b>	<b>15,326,025</b>

EXPORTS OF DOMESTIC MERCHANDISE.

<b>CLOCKS AND WATCHES:</b>				
Clocks and parts of.....	90,850	107,471	886,589	1,032,199
Watches and parts of.....	100,528	99,959	810,258	636,216
<b>Total.....</b>	<b>191,378</b>	<b>207,430</b>	<b>1,696,847</b>	<b>1,668,415</b>
<b>Jewelry .....</b>	<b>68,321</b>	<b>80,282</b>	<b>538,017</b>	<b>698,161</b>
<b>Other manufactures of gold and silver.....</b>	<b>33,568</b>	<b>26,293</b>	<b>208,081</b>	<b>213,982</b>
<b>Total.....</b>	<b>101,889</b>	<b>106,515</b>	<b>746,098</b>	<b>912,143</b>
<b>Plated ware .....</b>	<b>41,756</b>	<b>55,551</b>	<b>367,101</b>	<b>449,923</b>

11 months ended the same date, compared with the corresponding period of 1898, has been issued, and contains the accompanying figures relative to the jewelry trade.

**No Facts to Warrant These Articles Being Classified as Household Goods.**

WASHINGTON, D. C., Dec. 29.—Application has been made to the Treasury De-

partment by August Pol, through his mother, who died last March.

The Solicitor of the Treasury has rendered an opinion to the effect that the facts stated by the applicant would not warrant free entry of the articles as household effects, and in accordance therewith the Treasury Department has denied the application.



*No watch ever made has sold as well as No 333*

It is the only nickel watch that comes anywhere near the style and beauty of the fine gold cases :

It is 14-size and modeled so that it does not bulge out the pocket :

It has a jeweled movement, is thoroughly tested and carries the same guarantee of accuracy as we give all our watches:

It is the popular size for men, yet not too large for a boy: Not dead stock at any season —at this season it is *the quickest-selling article a jeweler can handle:*

Arabic, Roman or Card Dial:

**NICKEL OR GUN METAL.**

*New England Watch Co.*  
WATERBURY, CONN.

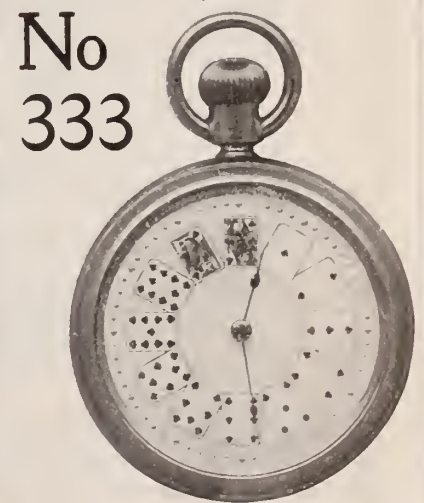

**S. STERNAU & CO.,**

204 CHURCH STREET, NEW YORK.

Manufacturers of **METAL WARES**

in Brass, Copper and Silver.

**CHAFING DISHES, KETTLES, TRAYS,**

Crumb Trays and Scrapers, Bread Baskets, Etc.

CATALOGUE ON APPLICATION.

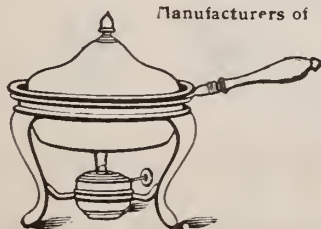

# TO RETAIL JEWELERS, WARNING

## Keep Tabs on the Tags and Swivels.

When you buy Blackinton Chains the stamps on swivels tell the story.

EACH TAG AND STAMP ON SWIVEL REPRESENTS A DIFFERENT QUALITY.

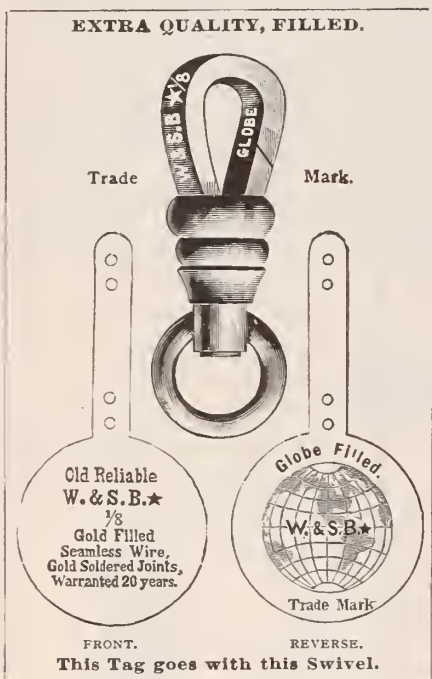

OLD RELIABLE

**W. & S. B. ★ GLOBE FILLED**

ARE EXTRA QUALITY AND WARRANTED TO ASSAY  $\frac{1}{8}$  GOLD.

OUR REGULAR

**OLD RELIABLE W. & S. B. ★**

ARE  $\frac{1}{10}$  PLATE AND SUCH AS WE HAVE MADE FOR 30 YEARS.

IF YOUR SWIVELS BEAR EITHER OF THE ABOVE TWO STAMPS YOU ARE SURE OF GETTING CHAINS THAT EXCEL IN

**QUALITY, DESIGN AND FINISH,**

THE GREATEST OF VIRTUES THAT COMBINE TO MAKE A LINE OF GOODS

**RELIABLE AND SALABLE.**

EVERY JOBBER CARRIES THESE CHAINS. INSIST ON SEEING THEM; A CAREFUL EXAMINATION WILL PROVE THE ABOVE.



MR. W. SUMNER BLACKINTON EXPLAINING THE DIFFERENT QUALITIES AS INDICATED BY THE STAMP ON THE TAGS AND ON THE GOODS.



**Each Article of this Grade  
is Stamped as above.**

**THIS IS  
OUR 2d QUALITY.**

**CAUTION**

Retailers when buying should be most careful to see that chains so stamped are not sold as either the old reliable W. & S. B. ★ GLOBE FILLED or the old reliable W. & S. B. ★. **THIS IS BEING DONE AND HAS BEEN DONE EXTENSIVELY.**

SECOND QUALITY.



**WARRANTED  
14 Kt. Plate.  
Seamless Wire.**

This Tag goes with this Swivel.

**W. & S. BLACKINTON.**

Providence, R. I.

New York, 14 Maiden Lane.

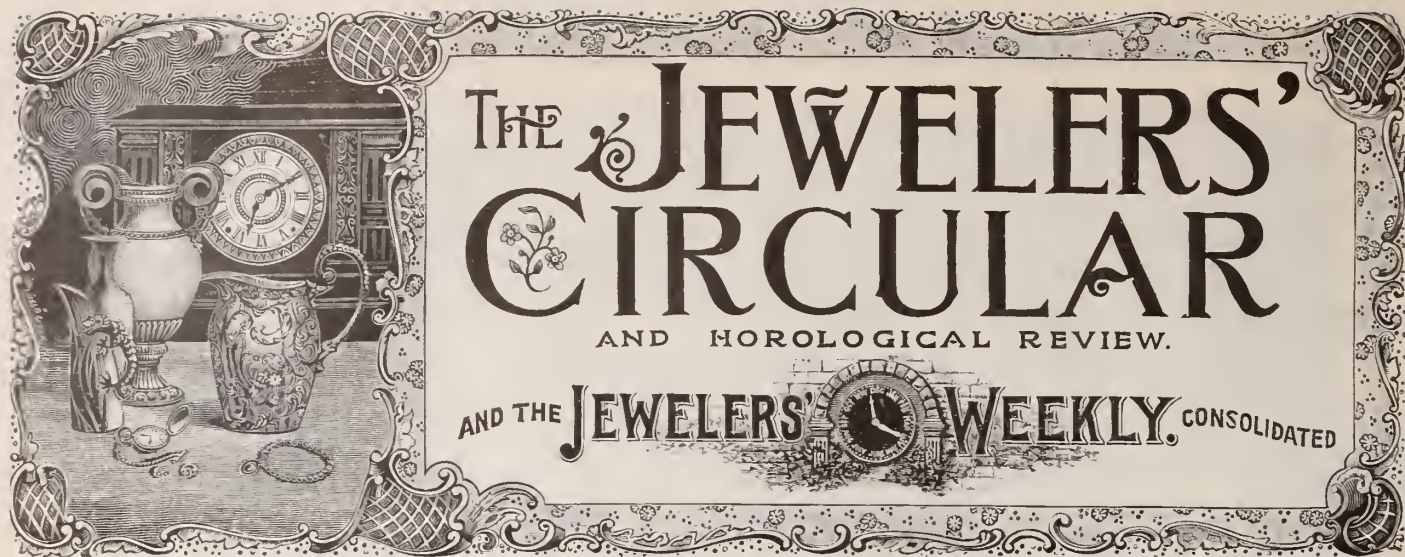

## *Announcement Extraordinary !*

The headpiece above tells a story of great interest to the entire jewelry industry. The story is there plainly told, but some fuller particulars are in order.

During several years past those connected with Jewelry Trade Journalism have become more and more convinced that the trade as a whole demands **ONE GREAT WEEKLY NEWSPAPER** to represent it; to be the chronicler of its happenings and the exponent of its best interests. It was this demand primarily that brought about the plan for the **CONSOLIDATION** of *The Jewelers' Circular* and *The Jewelers' Weekly* into one,

### **“THE JEWELERS' CIRCULAR and THE JEWELERS' WEEKLY CONSOLIDATED.”**

Thus will be merged into one comprehensive journal of the jewelry industry the Oldest Publication in the trade (*The Jewelers' Circular*) and the Oldest Weekly in the trade (*The Jewelers' Weekly*). Thus to the great accumulative influence and prestige of the one, derived from 30 years of unremitting endeavor, of broad, liberal policy, of conscientious study of the trade's interests—this *The Jewelers' Circular*—will be added the prestige obtained by 15 years of equally earnest work on varying lines—*The Jewelers' Weekly*—the sum total representing a measure of usefulness of practically limitless extent.

The uniting of these two journals into one will partake of none of the features of the so-called combine. It contemplates no economies, no curtailments. It will be formed through the will of some of the most expressive minds in the trade, that *one great weekly publication* can best serve the trade; and such a paper “*The Jewelers' Circular and Jewelers' Weekly Consolidated*” will ever be. The uniting of the facilities of the two journals will result in the production of one paper so broad and comprehensive in its scope, so accurate and complete in all its details, so representative of every department of the industry that “*The Jewelers' Circular and The Jewelers' Weekly Consolidated*” will unhesitatingly be universally considered as **THE JOURNALISTIC ORGAN OF THE JEWELRY TRADE**. Such a position each, save for the other, has held, but this high place will be fortified and held impregnable for all time to come.

With its extended circulation, its inexhaustible facilities, its accumulated prestige, and last but not least its hearty and responsive endorsement by the trade, “**THE JEWELERS' CIRCULAR and THE JEWELERS' WEEKLY CONSOLIDATED**” will begin the new era of its career with potentialities for usefulness to the jewelry industry that will be exercised to the utmost.

*The consolidation will take effect with issue of Jan. 31, 1900.*

**THE JEWELERS' CIRCULAR PUBLISHING COMPANY.**



# The Jewelers' Circular

AND  
HOROLOGICAL REVIEW.

PUBLISHED EVERY WEDNESDAY BY  
**THE JEWELERS' CIRCULAR PUB'G CO.,**  
CORBIN BUILDING, 11 JOHN ST., COR. BROADWAY,  
NEW YORK.

TELEPHONE: 1148 CORTLANDT.  
CABLE ADDRESS: JEWELAR, NEW YORK.

A JOURNAL DEVOTED TO THE INTERESTS OF JEWELERS,  
WATCHMAKERS, SILVERSMITHS, ELECTRO-PLATE MANU-  
FACTURERS, AND ALL ENGAGED IN KINDRED BRANCHES OF  
INDUSTRY.

Member of the American Trade Press Association.

Our editorial columns will contain our own opinions only, and we shall present in other columns only what we consider of interest or value to our readers. Advertising matter will not be printed as news.

Advertising rates in THE CIRCULAR are lower, considering the number of tradesmen reached by its large circulation, than in any other jewelry journal.

Notices of changes in standing advertisements must be received one week in advance; new matter can be received up to Monday.

### INFORMATION FOR SUBSCRIBERS.

#### Terms of Subscription, Postage Prepaid.

	PER ANNUM.
United States and Canada, - - -	\$2.00
Foreign Countries in Postal Union, - - -	4.00
Single Copies, - - - - -	.10

New Subscribers can commence at any time.

Payments for THE CIRCULAR, when sent by mail, should be made in a Post-Office Money Order, Bank Check or Draft, or an Express Money Order or Registered Letter. All postmasters are required to register letters whenever requested to do so.

Pay money only to authorized collectors having proper credentials.

**Returning Copies.** Returning your paper will not enable us to discontinue it, as we cannot find your name on our books unless your address is given.

**Changing Address.** In changing address always give the old as well as the new one. Your name cannot be found on our books unless this is done.

**Discontinuances** We will continue to send papers until there is a specific order to stop, in connection with which all arrearages must be paid; but such an order can be given at any time, to take effect at or after the expiration of the subscription. All such orders will be promptly acknowledged by mail.

**Liability.** The courts have decided that all subscribers to journals are responsible until arrearages are paid in full and an order to discontinue has been received by the publisher.

#### THE JEWELERS' CIRCULAR IN EUROPE.

Among the places in Europe where THE JEWELERS' CIRCULAR is on file are the following:

**LONDON**—First Ave. Hotel, Holborn, E. C.; Holborn Viaduct Hotel, Royal Hotel.

**PARIS**—Hotel de L'Athene, Rue Scribe.

**LEIPZIG**—Handels-Zeitung, für die gesamte Uhren-Industrie.

**BERLIN**—Deutsche Uhrmacher Zeitung, Jager-Strasse, 73.

**GENEVA**—Journal Suisse D'Horlogerie.

**AMSTERDAM**—Continental Club, Hotel Amstel.

**ANTWERP**—Diamond Club, Rue de Pelican.

Vol. XXXIX. Jan. 3, 1900. No. 23.

Every line of reading matter in THE JEWELERS' CIRCULAR, with the exception of the few brief extracts from exchanges, always properly credited, is written exclusively for this journal. Each issue of THE JEWELERS' CIRCULAR is copyrighted. Permission to quote is extended to other publications provided such quotations are properly credited.

## Precious Stone Imports for 1899.

THE report of Gen. Geo. W. Mindil, Jewelry Examiner at the Public Stores, New York, on the importations of precious stones and pearls into the Port of New York shows the total for the calendar year ended Dec. 31, 1899, to be \$19,321,752.55, the largest value ever brought through the Port of New York in the history of the jewelry trade. Of this \$5,907,534.76 represents uncut diamonds and \$13,414,217.79 cut diamonds, precious stones and pearls. That the amount would have reached over \$20,000,000 if the trade could have had all the goods desired, Gen. Mindil is sure, as the importations for December show a falling off from the figures for the same month for the past few years. The decrease in rough diamond importations for the past two months has been especially notable, evidencing that the cutters have not been able to obtain all the material desired by them. The figures for December, 1899, as compared with December, 1898, are:

December, 1899—Uncut,	\$245,917.34;	cut,	\$435,888.46
1898—	282,414.11;	"	669,156.51

A tabulation of the total importations for the past four calendar years is as follows:

	Cut.	Uncut.	Total.
1896 .....	\$2,194,076.74	\$2,763,406.24	\$4,957,482.98
1897 .....	4,368,913.44	2,677,413.95	7,046,327.39
1898 .....	8,034,616.51	4,900,198.94	12,934,815.45
1899 .....	13,414,217.79	5,907,534.76	19,321,752.55

The first year here tabulated (1896) was the last full calendar year under the old, injudicious and demoralizing 25 per cent duty.

### The Opening of the Year 1900.

IT is somewhat too early to go into particulars regarding the season just closed in its results upon the jewelry trade, but in general terms it may be safely asserted that rarely have sanguine hopes or predictions bearing upon the trade found such adequate realization as they did during the past season. From the many cities covered by THE CIRCULAR's correspondents come reports of universal satisfaction among the jewelry dealers in their respective communities. From the jewelry manufacturing centers come reports that the jewelers have had an excellent season, while the definite increase in the demand for gold jewelry is noted with satisfaction. It is a fact that the past season brought forth a call for a higher grade of product in all lines allied to the industry. The commercial bodies within the trade express gratification with the unprecedentedly few failures following the close of the Christmas trade; and, as a whole, the industry seems to be on a foundation more solid at the opening of 1900 than at the opening of any of the eight previous years at least. In forecasting the coming year's business sight will, of course, not be lost of the fact that 1900 will be a Presidential year and that some measure of election excitement, and therefore of interruption to business, may be reasonably expected. On the other hand, it must be remembered that any campaign having for its object the unsettlement of the currency has been pretty definitely rendered impossible by the inexorable logic of events during the recent years of

# PRIZE ESSAYS

—ON—

## JEWELRY STORE KEEPING.

The Jewelers' Circular, continuing its policy to offer from time to time, prizes for essays on matters connected with the conducting of a retail jewelry business, inaugurates a forthcoming series by offering the following nominal

### PRIZES FOR SUBJECTS.

**Prize \$5.00**—For title of Best Topic for competition on any matter connected with the running of a jewelry store.

**Prize \$3.00**—For title of Next Best Topic.

For each title of the Next Five Best Topics, a year's subscription to THE JEWELERS' CIRCULAR.

Competitors may send in as many TITLES OF TOPICS FOR COMPETITION as they desire, but only one will be selected for the prize competition; that is, no competitor can win more than one prize.

[All Topics must be in by Jan. 28.]

prosperity. That important element of all business development, confidence, is possessed by the business community now to a greater extent than probably ever before. It may be truly said that the business community looks forward to 1900 with almost equally mixed feelings of hope and confidence.

DURING the pre-holiday days THE CIRCULAR received from many retail jewelers a large number of newspapers containing their advertisements. The great bulk of these advertisements were of the same general character, and we will consider them collectively. These advertisements occupied from one-quarter to a full page each, and as, in many cases, several jewelers advertised simultaneously, the jewelers' advertising formed a very salient feature of the newspapers. The advertisements were a succession of illustrations of jewelry, watches, silver articles and other jewelers' goods with descriptions and prices, all in the general manner of the announcements of the department stores. This paper, as long ago as three years, theorized that such advertising by the jewelers would prove a strong bulwark against the advertising methods of the department stores. Since then many jewelers, whether influenced or not by our ruminations we cannot say, have advertised extensively in the manner advocated, this season particularly. What degree of success awarded the jewelers' bravery and expenditure remains to be learned, but the theory remains unchanged. The only qualification to be offered is that this method may not appeal to the so-called fine custom, as it is essentially appealing to the general public, which in many regards is not a discriminating public, being particularly attracted by apparently low prices for apparently expensive articles. We would like to hear from some of these advertisers as to the results of their enterprise.

## BUYERS' INFORMATION BUREAU.

Questions as to the makers of certain lines of goods, where to buy certain lines, where certain kinds of work are done, the owners of certain trade-marks and other matters relating to the buying branch of a jewelry business will be cheerfully answered under this department. The reader cannot ask too many questions.

ASHEVILLE, N. C., Dec. 28, 1899.

Editor of THE JEWELERS' CIRCULAR:

Having read query under this department of THE CIRCULAR will say that I possess several rhodolites of fine color and brilliancy, weighing 2½ karats, and several smaller ones, which I can guarantee, as I cut same myself. Very respectfully,

JESSE ING.

INDIANAPOLIS, Ind., Dec. 18, 1899.

Editor of THE JEWELERS' CIRCULAR:

I wish to bother you for a few pointers if you will be so kind to answer. I enclose one stone. We call it here an Egyptian lucky stone. I have written to all the stone dealers in New York, also to several in Providence, R. I., for these stones, but could find only one firm who could give me any idea as to where I can buy them in gross lots, to be used in mounting up cheap jewelry and repairing same. Kindly investigate this for me as I can use large quantities of these stones if I can buy them low enough. Also want to know where I can buy sea beans and cats'-eyes in gross lots to be used in mounting up wire jewelry. Thanking in advance for your trouble and kindness, I remain,

Yours respectfully,

LON R. MAUZY.

ANSWER:—If correspondent will address Allen & Jonassohn at their Providence, R. I., office, 212 Union St., he will probably get what he wants or they will advise him where the articles wanted can be obtained.

HARRISBURG, Pa., Dec. 26, 1899.

Editor of THE JEWELERS' CIRCULAR:

Will you please kindly inform me where I can buy blanks for cutting; also cut glass machinery? Thanking you in advance, believing you will be able to give me the desired information, I remain,

Yours very respectfully,

E. L. EGOLF.

ANSWER:—Concerns who furnish glass blanks for cutting are: C. Dorflinger & Sons, 36 Murray St., New York; Libbey Glass Co., Toledo, O. In the cutting of glass the plant consists of frames, stones and mills. Mills can be obtained from Holland & Gabriel, 354 Humboldt St., Brooklyn, N. Y.; stones are imported and may be obtained from the Pike Mfg. Co., 51 Chambers St., New York; while frames can be made by any carpenter who has seen such articles.

ANDERSON, Ind., Dec. 27, 1899.

Editor of THE JEWELERS' CIRCULAR:

Kindly advise us at once who makes talcum powder boxes in cut glass with sterling tops. An early reply will oblige

Yours,

D. & J. ROSENBAUM.

ANSWER:—Gorham Mfg. Co., 19th St. and Broadway, New York; Mauser Mfg. Co., 14 E. 15th St., New York; Woodside Sterling Co., 11 John St., New York; the Howard Sterling Co., Providence, R. I., and other silversmiths make these articles.

### The Career of the Late F. E. Treibs.

A brief note in THE CIRCULAR last week announced the death on Dec. 26 of F. E. Treibs, founder and senior partner of the firm of F. E. Treibs, Oberstein, Germany, and of Treibs Bros., 68 Nassau St., New York.

The deceased, who was nearly 80 years



THE LATE F. E. TREIBS.

of age, was one of the most prominent European dealers and cutters of opals. He was born in Oberstein, Germany, June 16, 1820, and started in the agate and precious stone business in 1842. He soon became recognized as one of the leading merchants in the precious stone cutting district of Germany and obtained the reputation of being one of the most able and successful business men in that trade. For many years he made a specialty of opals and his business increased so that at the time of his death over 150 hands were employed in his factory upon that stone line. As his five sons grew up to manhood he took them into the concern and extended his business into foreign countries, founding among others the branch, Treibs Bros., in New York.

During his career, in honor of his well deserved success, Mr. Treibs was the recipient of many honors and testimonials. Among other decorations which he received was a golden cross presented by the Grand Duke of Oldenberg for his services rendered to the sick and wounded soldiers during the Franco-Prussian War. Mr. Treibs married in 1847, his wife dying in 1881. He is survived by his five sons, five daughters and 23 grandchildren.

Granting to a person the exclusive right to sell goods within certain limitations is of itself sufficient as a consideration for a contract to purchase such goods.

To enable one to rely on a statement sent to him by another as a stated account between them, it is incumbent on him to prove acquiescence in same by the other person.

# M D C C C C

May it be to all our  
Customers—past, present  
and future—a Happy and  
Most Prosperous Year

## CROSS & BEGUELIN

Importers and Cutters of Diamonds and Precious Stones

43 Rue de Mestay, PARIS

Telephone,  
2188 Cortlandt

17 Maiden Lane, NEW YORK

**New York Notes.**

The city of New York has entered a judgment for \$498.85 against Obadiah L. Sypher.

J. W. D. Block, who has heretofore represented Cross & Beguelin, will in the future travel for L. Witsenhausen, 37 Maiden Lane, in the Middle and Western States.

The factory of the Fahys Watch Case Co., at Sag Harbor, which closed down Dec. 22 for the annual clean-up and inventory, will reopen next Monday. The usual excursion trip to New York for the benefit of the employes was run last week by the Long Island Railroad.

Saul Prager, a former wholesale jeweler, who some months ago filed a voluntary petition in bankruptcy, made an application for the discharge of all his debts last week in the United States District Court. All creditors interested are required to attend the hearing before Judge Brown, 10 A. M., Jan. 17, 1900, to show cause why the discharge asked for should not be granted.

Jno. N. Blair, counsel for the gentlemen who are forming the trust and safe deposit companies in the jewelry trade, said Friday that although work had been done in connection with the formation of the companies, there was nothing to be given out for publication up to that time. A meeting of all those interested, for the purpose of the formation of the companies, he said, would probably be held the latter part of this week or the early part of next.

Mr. Florence Kroeber, receiver of the F. Kroeber Clock Co., has notified all interested in the concern that a general meeting of the creditors has been called for 2 o'clock P. M., Feb. 28, 1900. It will be held at the office of Steinhart & Goldman, attorneys for the receiver, 31 Nassau St. At this meeting all accounts and demands for and against the corporation, and all open and subsisting contracts will be adjusted and the amount of money in the hands of the receiver will be declared.

In the dispatch from Hartford, Conn., published last week, speaking of the verdict obtained by Green Bros., of this city, against M. J. Garfinkel, Hartford, THE CIRCULAR correspondent omitted to state that the judgment for \$41 was practically the full amount sued for. This was due to the fact that Green Bros. sued for the full bill, \$75, but rather than confuse the trial by new issues, consented to take back a lathe worth \$34, claimed to be defective. This was agreed to, and the jury brought

in a verdict for the full amount of the difference.

The judgment obtained nearly a year ago by Margaret Willison against the Jewelers' and Tradesmen's Co., of New York, in an action on an insurance policy, has been reversed by the General Term of the City Court. The reversal and the direction for a new trial are on the ground that the party insured died within 30 days after the policy was taken out, which was against the regulations of the company, and also on the ground that the company's constitution and by-laws, which should have been read in connection with the policy, were not admitted as evidence at the former trial.

Another attempt to remove Wilbur F. Wakeman, the Appraiser of the Port of New York, is now about to be made, this time by the Merchants' Association of New York. This association are now discussing the advisability of circulating a petition to all prominent merchants, asking the President to remove Mr. Wakeman. It is said this petition will be prepared and sent to Washington if certain alleged abuses, now complained of, are not quickly removed. Many merchants in the Merchants' Association claim that the rulings recently made by the Appraiser on certain articles and his conduct of the office are injuring New York and are apt to drive importations to other cities. Mr. Wakeman denies all the charges except as to his rulings, and claims that if the merchants are not satisfied they have am-

ple opportunity for testing the validity of these rulings by an appeal to the Board of Appraisers.

A dispatch from Summit, N. J., last week, stated that there is considerable comment over the death of the late Louis Mandelstam, a jeweler of that town, who died Nov. 2, in the German Hospital, New York, after four weeks' illness. The widow of the deceased, it is stated, has been annoyed by these comments and by anonymous letters and communications, enclosing clippings of poison trials and similar articles. Mandelstam had been a bachelor until within a short time of his death, when he married Miss Zella Ber- man. He became ill in October, and though several prominent physicians were called on to attend him, he became so ill that he was taken to the German Hospital, where he died after an operation. By his will the deceased left to his wife all his property, except \$300, which he left to his mother in Russia. His brother in Russia recently communicated with the Russian Consul in New York, asking him to hurry up the payment left to the mother. The widow claims that she is legally prevented from paying anything out of the estate for some months yet, until she and the other executor, Henry Wolff, are authorized to do so by the Court.

With a mass of frozen earth wrapped in newspaper a man smashed a plate glass window of Mrs. T. Lynch's jewelry store, Union Sq. and 14th St., Saturday night. He was immediately arrested.

**C. Dorflinger & Sons,**

36 MURRAY STREET, NEW YORK,

MANUFACTURERS OF

**FINE GLASSWARE,**

desire to establish an agency in Chicago with control of middle west, in connection with some representative house in a kindred line.

1851.

1899.

**THE CHATHAM NATIONAL BANK, NEW YORK.**

CAPITAL STOCK, - - - \$450,000  
 UNDIVIDED PROFITS, - - - 974,518

GEO. M. HARD, President.

H. P. DOREMUS, Cashier.

W. H. STRAWN, Ass't Cashier.

He gave his name as "Jack Cole of this earth," and would give no further information about himself. He was well dressed and is believed by the police to be insane. Nothing was stolen, but the value of the window smashed is placed at \$200.

M. L. Schneider has entered a judgment for \$122.60 against August Trenkman.

The suit in the United States Circuit Court by Tiffany & Co. to obtain a final decision in regard to the tariff on drilled pearls, which was on the calendar to come before Judge Wheeler this week, was Thursday marked off for the term.

Geo. C. Waldo, president of the Excelsior Savings bank, who died at his home in Mount Vernon, Saturday, was at one time in the jewelry trade and served several years as a youth in the employ of the old firm of Ball, Black & Co.

Among the many loving cups presented at the end of the season was one to Theo. L. DeVinne, the dean of American printers, and another to Surrogate Varnum, of New York. The former was presented to Mr. DeVinne by his fellow printers and competitors in the Typothetae, and was a souvenir of his 71st birthday, which occurred on Christmas day. The latter was presented by the employes of the Surrogate's office to Mr. Varnum upon his retirement from that position.

Stern Bros. & Co., importers of diamonds and manufacturers of jewelry, announce that two of their employes were given an interest in the concern January 1st. Leo Oettinger, who has been with the firm for the past 18 years, was admitted to an interest in their diamond department, and Arthur Simons, who has also been with them an equally long time, was admitted to an interest in their manufacturing jewelry department. The firm name and the general partners of the concern remain unchanged.

Michael Cavanagh, 23 years of age, was arrested Friday on a charge of stealing two rings valued at \$65 from Henry Rohlf's, retail jeweler, 997 Fulton St., Brooklyn. Mr. Rohlf claims that the prisoner called at the store and asked to see some rings, and when the two rings referred to were shown to him, he put them on his finger and then ran away. Mr. Rohlf chased the prisoner and cap-

tured him. When a policeman took him to the station house Cavanagh was still in possession of the rings. A charge of grand larceny was entered against him and he was held for examination.

A reward of \$1,000 has been offered for the return of a wallet alleged to contain about \$10,000 worth of diamonds and precious stones lost Sunday night. The loser, Benj. Crooks, who is proprietor of a restaurant at 126½ Canal St., and who says he is a dealer in jewelry as well, claims that the pocketbook disappeared from his inside coat pocket somewhere between his restaurant and his home at 1150 Third Ave., Brooklyn. Mr. Crooks says that he boarded a Third Ave. car at Canal St., went to the Bridge and from there took a Brooklyn trolley, and that the pocketbook must have undoubtedly slipped out while he was on the cars. For the return of its contents to 126½ Canal St. he says he will pay \$1,000 and ask no questions.

The imitation pearls, nearly 1,000,000 in number, seized some time ago from Francois Bock upon his arrival in this country, will be appraised by a special board of three to-day at the United States Public Stores, Christopher and Washington Sts. Bock, it will be remembered, is the Paris and Providence jeweler who was arrested on a charge of smuggling these goods. He is out on bail pending trial on the criminal charge and is a claimant in the action brought by the Government to confiscate the imitation pearls for non-payment of duty. It was from the latter proceeding that Bock obtained from the United States District Court an order for the special appraisement by a board of three outside dealers. The Court appointed Alfred Krower, of Albert Lorsch & Co.; E. H. Nordlinger, of Nordlinger & Mamluck, and Meyer Goodfriend, of Goodfriend Bros., to make the appraisement, and these gentlemen Saturday filed a notice that the appraisement would take place to-day.

In the absence of fraud or duress, ignorance of law in the execution of a contract, not mixed with accident or mistake of fact, is no ground for relief.

In an action against a carrier for breakage, the burden is on the shipper to show the carrier's gross negligence, for which only it contracted to be liable.

INDEX TO ADVERTISEMENTS.

Aikin, Lambert & Co.....	2
Aikin, Lambert Jewelry Co.....	2
Alford, C. G., & Co.....	24
American Watch Case Co.....	39
American Waltham Watch Co.....	20
Arnstein Bros. & Co.....	52
Avery & Brown.....	38
Ballou, B. A., & Co.....	19
Bassett Jewelry Co.....	2
Bell Watch Case Co.....	15
Bigney, S. O., & Co.....	35
Billings, Chester, & Son.....	9
Blackinton, W. & S.....	26, 27
Bonner & Co.....	17
Bowden, J. B., & Co.....	8
Bradley Polytechnic Institute.....	52
Carter, Hastings & Howe.....	9
Chase Mfg. Co.....	19
Chatham National Bank.....	31
Clark & Coombs.....	17
Clyde Line.....	48
Cross & Beguelin.....	17, 30
Crossman, Charles S., & Co.....	33
Crouch & Fitzgerald.....	51
Crown and Lion Watch Cases.....	47
Day, Clark & Co.....	17
Deutsch Bros.....	48
Dorfinger, C., & Sons.....	31
Dubois Watch Case Co.....	50
Dueber-Hampden Co.....	15
Eaton & Glover Co.....	41
Eisenmann Bros.....	12
Eliassof Bros. & Co.....	39
Esser & Barry.....	48
Fahys, Jos., & Co.....	4
Fairchild & Johnson Co.....	52
Field & Beattie.....	52
Foster, Theodore W., & Bro. Co.....	2
Frankel's Sons, Jos.....	7
Freund, Henry, & Bro.....	32
Friedlander, R. L. & M.....	52
Fuchs, Ferd., & Bros.....	48
Goodfriend Bros.....	9
Gorham Mfg. Co.....	23
Hamilton & Hamilton, Jr.....	11
Hancock, Becker & Co.....	19
Harris & Harrington.....	52
Haskell, H. C.....	39
Hedges, Wm. S., & Co.....	8
Heimberger & Lind.....	51
Hraba, Louis W.....	2
Jacot & Son.....	48
Juergensen, Jules.....	44
Kahn, L. & M., & Co.....	52
Kahn's Sons, James.....	12
Ketcham & McDougall.....	48
Knowles, Dr.....	48
Knowles, J. B. & S. M., Co.....	21
Kohn, Alois, & Co.....	52
Lederer, S. & B., Co.....	51
Ledos Mfg. Co.....	48
Lelong, L. & Bro.....	52
Levy, L. W., & Co.....	52
Lintz, Jules J.....	50
Lorsch, Albert, & Co.....	52
Mabie, Todd & Bard.....	51
Malliet, C. G., & Co.....	8
Martin, S.....	36
Mathews & Prior.....	12
Mathey Bros., Mathez & Co.....	39
Mauran, John T., Mfg. Co.....	37
Mausser Mfg. Co.....	17
Mercantile National Bank.....	40
Mossberg & Granville Mfg. Co.....	13
Mount & Woodhull.....	8
Myers, S. F., Co.....	40
New England Watch Co.....	25
Neuhaas, Theodore, & Co.....	36
Nissen, Ludwig, & Co.....	10
Noble, F. H., & Co.....	36
Omega Watches.....	13
Oppenheimer Bros. & Veith.....	8
Patek, Phillippe & Co.....	48
Potter, Wm. K.....	40
Remington Typewriters.....	39
Reichhelm, E. P., & Co.....	52
Reisner, L. C., & Co.....	3
Rich, H. M., & Co.....	50
Rogers, Wm., Mfg. Co.....	38
Roy Watch Case Co.....	42
Saunders, John F.....	9
Schulz & Rudolph.....	44
Sherwood, John W., & Co.....	14
Simmons, R. F., & Co.....	6
Simmons & Paye.....	48
Simons, Bro. & Co.....	48
Smith, Alfred H., & Co.....	10
Smith, Wm., & Co.....	48
Stern Bros & Co.....	12
Sternau, S., & Co.....	20
Sussfeld, Lorsch & Co.....	44
Towle Mfg. Co.....	36
Treibs Bros.....	41
Valfer, S., & Co.....	38
Vrieslander & Moreels.....	41
Wadsworth, G. F.....	36
Wallace, R., & Sons Mfg. Co.....	6
Waite-Thresher Co.....	43
Westphal, W. C. A.....	44
Wheeler, Havden W., & Co.....	16
Whiting, F. M., & Co.....	41
Wood, Chas. F., & Co.....	52
Wood, John R., & Sons.....	38
Wood & Hughes.....	48
Woods & Chatellier.....	12

To Our Customers and Friends:

It affords us great pleasure to extend to you our congratulations on the satisfactory business conditions during the season just ended, and our most sincere wishes for a continuance of the same in 1900, which, we trust, will prove to be an extremely Happy and Prosperous New Year for you all.

HENRY FREUND & BRO., 9, 11, 13 MAIDEN LANE, NEW YORK.

## Special Notices.

Rates 75c. per insertion for notices not exceeding 3 lines (25 words); additional words 2 cents each. If answers are to be forwarded, postage stamps must be enclosed. Two insertions, 15 per cent off; three insertions, 20 per cent off; four insertions or more, 25 per cent off. Payable strictly in advance.

Display cards on this page will be charged at \$2.00 per inch for first insertion, subject to same discount as above for subsequent insertions.

Under the heading of **SITUATIONS WANTED** on this page advertisements will be inserted for **One Cent a Word**, each insertion, no discount, but no advertisement will be inserted for less than 25 cents. This offer refers to **SITUATIONS WANTED ONLY**. Payable strictly in advance.

In all cases if answers are to be forwarded, 10 cents extra to cover postage must be enclosed.

## Situations Wanted.

**WANTED**—A position to sell optical goods either as house salesman or traveler. Address, "Optics," care Jewelers' Circular.

**SITUATION WANTED** as salesman; watches or jewelry, experience with both; either to travel or office. Address, Y. W. G., care Jewelers' Circular.

**AUCTIONEER**, general experience, specialty, jewelry, silver and porcelain ware wishes a position. Address, "Auctioneer W. S. C.," care Jewelers' Circular.

**PRACTICAL DESIGNER**, with 15 years' experience in all branches of sterling silver ware, desires position; all references furnished. Address "Sterling," care Jewelers' Circular.

**SUPERINTENDENT AND DESIGNER** with large experience in all branches of sterling silver ware desires position; best of references. Address "Designer," care Jewelers' Circular.

**WANTED**—A silver or gold line of goods to carry in connection with another through New England and Middle States, on commission. Address, "New England," care Jewelers' Circular.

**EXPERIENCED TRAVELING SALESMAN**, 10 years on the road and acquainted with the best trade in the west and middle western States, is open for engagement Jan. 1 to 15; best of references. Address, D. G., care Jewelers' Circular.

**FIRST-CLASS WATCHMAKER** and engraver, age 26, have had 12 years' experience, can take full charge of store if wanted, first-class references can be furnished; none but good houses need answer. Address C. C., care Jewelers' Circular.

**WOULD LIKE** a position as traveling salesman for manufacturing or wholesale jewelers; will work on small salary for a few months on trial; young man, single, good references and knows the business thoroughly. Address, W. J., care Jewelers' Circular.

**AN OPTICIAN**, watchmaker and engraver wants a steady position with a good firm; understands the business thoroughly; young man, single, sober and steady; have tools and trial case; state salary in first letter; all references. Address "Optician," care Jewelers' Circular.

**WANTED**—Situation by watchmaker, engraver and salesman; American, 33 years old, 25 years' experience at bench, five years with present employer; fully competent to take entire charge of store or department; if you want sober and industrious man, write me; personal reasons for desiring change. Address "Blue 19," care Jewelers' Circular.

## Help Wanted.

**WANTED**—A traveler acquainted with gold pen trade. Address with particulars, Box 1155, New York City.

**SALESMAN FOR SOUTH** — Experienced man wanted, no other need apply. Averbek & Averbek, 19 Maiden Lane, New York.

**AN EXPERIENCED TRAVELER** for the middle West to carry a line of diamonds and watches. Address with full particulars, R. A., care Jewelers' Circular.

**WANTED**—A first-class traveling man to represent me in the nearby states; one with experience necessary; good opening for a "hustler." L. W. Rubenstein, 54 Maiden Lane, New York.

**WANTED**—Two first-class manufacturing jewelers and stone setters; one first-class engraver and jeweler; references required. Geo. Wetstein, manufacturing jeweler, Cedar Rapids, Iowa.

**WANTED**—An experienced traveler for New York, Pennsylvania and the west. To the right man good salary will be paid; must have first class references. Address, Harper, care Jewelers' Circular.

**WATCHMAKER** who is engraver, jeweler, salesman, stockkeeper and all-round helper with tools; steady job; send sample of engraving, and photo; state wages wanted and full particulars. Address, "Jeweler," care Jewelers' Circular.

**WANTED**—A first-class man as salesman, watchmaker and engraver; one competent to take entire charge of our business; none others need apply; to such a man we offer a permanent position at a good salary. Answer with references, experience, age, etc., Nat. Kaiser & Co., Atlanta, Ga.

**AFTER JAN. 1**—A first-class manufacturing jeweler and stone setter who can make all kinds of diamond mountings, cluster work, and understands enameling and the use of dynamos for gilding and plating, as foreman in a newly equipped shop with six to eight men; highest salary and permanent position to right man; best of references required. Address G. O., care Jewelers' Circular.

## Business Opportunities.

**JEWELRY STOCKS BOUGHT**—Retailers wishing to dispose of surplus or entire stock of diamonds, watches and jewelry can find quick, cash, strictly confidential buyer by addressing S. Marx, 22 Lispenard St., New York City.

**\$500 WILL BUY** stock and fixtures of good paying jewelry and optical business in growing live town in South Jersey; this is a good chance for young man with small capital who is a good, all-round workman; present owner must go to Europe and would make sacrifice. Address, N. J., care Jewelers' Circular.

## Wanted Immediately,

experienced and thorough workman who can do difficult jewelry work (diamond setting included). Good engraver and do watch work; must be of neat appearance and capable of waiting on retail trade. To the right man a permanent position and a good salary. Gilt edge reference required; must be sober, single and strictly honest. Send sample of engraving with application.

Address, H. J. HOMRICH,  
915 Third Ave., Huntington, W. Va.

## TO LET

IN THE  
**UPTOWN JEWELRY and SILVERWARE DISTRICT,**  
UNION SQUARE, WEST,

From Feb. 1, for a term of years, No. 19, (second door above Tiffany's), large store, basement, first and second floors; separately if desired. Janitor on premises. Apply to

HORACE W. DAY,

17 STATE STREET, NEW YORK.  
TELEPHONE, 724 BROAD.

## CASH OFFERS.

If at any time you have offered to you by your customers any jewelry containing diamonds, pearls or other precious stones, and you do not care to buy them yourself, send them to us and we will submit an IMMEDIATE CASH OFFER. Trade and Bank References if desired. Established 1880. Correspondence solicited.

CHARLES S. CROSSMAN & CO.,  
3 Maiden Lane, New York.

## Connecticut.

Dina Plaut, Meriden, has received a discharge in bankruptcy from the United States Court at Hartford.

R. R. Borean, of Detroit, Mich., was in Bristol a few days ago endeavoring to interest local manufacturers in a patent illuminator for a clock dial.

Robert M. Wilcox, of Wilcox & Evertsen, a sterling silver department of the International Silver Co., is shortly to sever his connection with this concern and will probably engage in business in New York.

The plant of the Barbour Silver Co., a branch of the International Silver Co., is being transferred from Hartford to Meriden. It will occupy the factory formerly used by the cut glass department of the old Meriden Silver Plate Co.

The new electric clock company in Bristol have been formally organized and the permanent officers and board of directors elected. W. B. Brainard is the promoter of the enterprise. The company wish to get in condition where they can manufacture by July 1 next.

There is talk of reorganizing the Burgess Cut Glass Co., Middletown. The company were unable longer to occupy their old factory as their lease had expired. Now that they have ceased doing business some idea of the value of the company to the community is being had.

Chester Shepard, a former resident of Middletown, has been elected an alderman from Ward 1, in Melrose, Mass. Mr. Shepard for 17 years was employed as a salesman by the Middletown Plate Co., and eight years ago commenced the manufacture of sterling silver souvenir articles.

Isaac Holstein, a diamond setter in the employ of Henry Kohn & Sons, Hartford, for the last nine years, died Dec. 27, of pneumonia, at his home, 24 Morgan St. Mr. Holstein had been sick for about two weeks. He was 49 years old and was born in Warsaw, Russia. He learned the diamond setting trade there and came to this country in 1866.

Frederick W. Porter, of Porter & Dyson, was stricken with paralysis in his jewelry shop, New Britain, at 11 o'clock last Saturday morning. He was at work as usual, and as he was walking from one bench to another he sank to the floor. Mr. Porter was removed to his home. He is 72 years of age, and this is the second time he has been stricken.

The following pay taxes in Waterbury on the amounts given: New England Watch Co., \$100,000; Plume & Atwood, \$180,100; Rogers & Bro., \$75,000; Rogers & Hamilton Co., \$30,000; Scovill Mfg. Co., \$400,000; Waterbury Brass Co., \$400,200; Waterbury Buckle Co., \$60,000; Waterbury Button Co., \$55,000; Waterbury Clock Co., \$114,100; Waterville Cutlery Co., \$13,000; H. L. Wade, \$12,850.

The E. N. Welch Mfg. Co., Bristol, were to receive on Jan. 1 the plans and specifications for their new case shop building. The new shop will be 200 feet long, 50 feet wide, three stories high and will be of brick. The loss on the burned building and its contents has been adjusted with the insurance companies.

"THE EMPIRE WESTWARD TAKES ITS WAY"

# WESTERN SUPPLEMENT

## OF THE JEWELERS' CIRCULAR

VOL. XXXIX.

NEW YORK, WEDNESDAY, JANUARY 3, 1900.

No. 23.

### Chicago Notes.

All communications in reference to the Chicago department of *The Jewelers' Circular*, addressed to Stephen Parlin, 1522 Lill Ave. (Telephone, Lake View 397), Chicago, will receive prompt attention.

Reports from the various sections by mail show a most satisfactory holiday trade.

The Illinois Watch Case Co. will open a New York office shortly after the first of the year.

H. G. Nye, Chicago representative of C. Rogers & Bros., left Thursday for the east, where he will visit the factories as well as the New York salesrooms.

Stocktaking is occupying the attention of a number of firms, more particularly western branches of eastern factories. It is a little early yet for the jobbers.

Mr. Loeb, Wadsworth Watch Case Co., is back from a visit to the new factory at Dayton, and pronounces it "the best and finest ever built for our business."

Enterprise Optical Mfg. Co., of Chicago, have incorporated with a capital of \$25,000 to manufacture optical goods and other specialties. Incorporators: A. C. Roebuck, T. N. Grier, William H. Tuttle.

A. E. Bentley, general manager for the United States Watch Co., Waltham, Mass., was in town during the holidays to spend Christmas and New Year's with his family, also to attend to business affairs of the company.

F. L. Merrick, manager of the Chicago office of Bradley & Hubbard Mfg. Co., goes east the coming Saturday for a 10 days' visit at the factory, an annual affair with him, for the looking over of designs for the coming year.

George Kuehl, importer, says twice as many cuckoo clocks have been sold in the past 12 months as in any previous year, and that the money value has considerably more than doubled, as there was a larger proportion of the higher priced goods sold.

Charles Spencer, for the past year with Stein & Ellbogen Co., resumed his old position on the first of the year as manager for B. F. Norris, Alister & Co. He left the latter firm some three years ago and engaged in business in the east, returning to Chicago a year ago, when he made a connection with Stein & Ellbogen Co. Ed. Hoffman, for the past four years buyer and traveler for F. C. Happel Co., succeeds Mr. Spencer at Stein & Ellbogen Co.'s. Mr. Shafer, of B. F. Norris, Alister & Co., takes charge of their watch department, and has general oversight as house salesman.

"Christmas and New Year's are royally good days" came in chorus from nine Chicago throats on Friday. "but when it comes to a trip to Elgin with such guests as we had the other holidays seem a little tame." The occasion for this chorus was a little trip planned by the Messrs. Eppenstein, of Elgin, for a few of their friends on Thursday. The party consisted of George Moore, W. J. Miller, Frank Sproehle, R. A. Kettle, Jack Corey, Lem W. Flershem, H. M. Tenney, Jacob Franks, and last, but by no means least, George Gubbins. They were the guests of M. C. and S. C. Eppenstein, of the Illinois Watch Case Co., who extended every courtesy. They were first escorted to the "case factory"—it is never called anything else in Elgin—where opportunity was given to see and inspect every process of evolution the case goes through, which was followed by a luncheon in the evening at the home of M. C. Eppenstein, president of the company. On the returning train the subject of discussion was "There may be other towns, but Elgin is good enough for us."

The International Silver Co. have leased the entire upper floor of the Lapp & Flershem building, northeast corner State and Adams Sts., and the various Chicago branches of the corporation will be consolidated in the new quarters on or a little before the first of May. The Chicago leases of all the branches expire at that time with the exception of the Simpson, Hall, Miller & Co., which, it is understood, has two years to run. The firms whose salesrooms will form part of the consolidation are Factory A, Barbour Silver Co., Mr. Demarest, manager; Factory C, Holmes & Edwards Silver Co., Mr. Browne, manager; Factory D, Manhattan Silver Plate Co., Mr. Browne, manager; Factory E, Meriden Britannia Co., Mr. Dungan, manager; Factory L, Simpson, Hall, Miller & Co., Mr. Burchard, manager; Rogers & Hamilton Co., Mr. Caldwell, manager. No changes are known to be contemplated in the management of the several lines except the general supervision that is vested in Mr. Sercomb. Another change in policy is that by which all travelers of the International will in future travel direct from the east and not from the Chicago office. All the International houses are working nights on their annual inventories, which are due in the east on Jan. 5.

Jeweler F. S. Palmer will leave Orion, Mich., to take possession of his father's jewelry store in Rochester, Mich., which is being remodeled for his occupancy.

### Cincinnati.

The engagement is announced of I. N. Fox, of Fox Bros. & Co., to Miss Carmen Wolf, of Bryan, O.

Walter Myer, who represented Joe Plaut, has engaged to travel for S. & H. Gilsey.

Among the dealers who came up to Cincinnati last week to report their excellent trade Christmas week, was W. W. Howe, Carlisle, Ky., who says the business was beyond all anticipation.

A cable from abroad announces the safe arrival of Mr. Gruen, of D. Gruen & Sons, watch manufacturers of Glashütte, Germany, to which city he has returned for the Winter, stopping awhile at Paris.

Hugo Lindenberg, who embarked in the wholesale business last Summer, returned last week from his last trip for the year and reported his new venture a successful one. He is encouraged to invest more money this year, and will remain at home to buy goods all this month.

News reached this city last week that Joseph Swartz, a former Cincinnati man, who has figured in many escapades, narrated in *THE CIRCULAR* several years ago, is wanted in Council Bluffs, Ia., for pawning paste diamonds for the amount of \$2,800 and skipping out. He first pawned real diamonds, redeemed them and then pawned the paste articles.

The current will be stocktaking week with some of the jewelers, and in most branches of business, and it is safe to assume that most of the houses will have small stocks to inventory, while the manufacturers will have little of their product on hand. Business has been so active that the goods have been rapidly delivered into the hands of the consumer.

Pierre Petit, who has a little jewelry shop on Elm St., has opened a recruiting office for the Boer army, and as the store has been receiving daily letters from men who want to recruit or join a regiment to fight with Gen. Joubert, United States District Attorney Bunday will make an investigation, and if he finds the operations of Mr. Petit contrary to the neutrality laws, he will call the attention of the Washington authorities to the matter. Petit says he is recruiting for the ambulance corps.

Kotzebue Platinum Co., East St. Louis, Ill., have incorporated with a capital stock of \$2,500; incorporators, August Priesmeyer, G. W. Henry and Edward L. Briggs.

# The S.O. Bigney & Co.'s New Jewelry Plant.

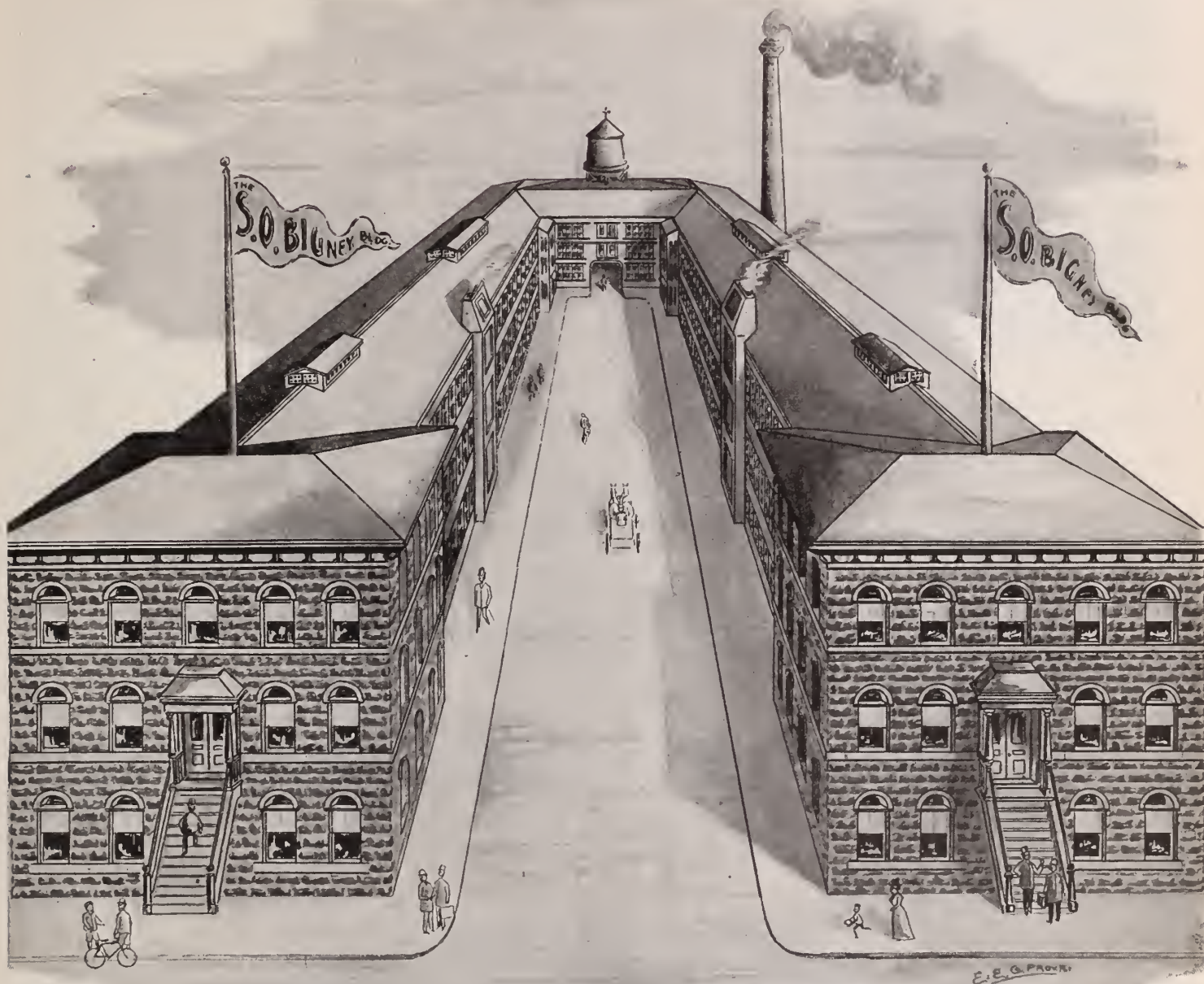

## TO THE JOBBING TRADE OF THE COUNTRY.

ATTLEBORO, MASS., Jan , 1900

*Gentlemen:*—We take great pleasure in announcing that we are now located in our new plant at Attleboro, the largest and best equipped chain plant in the United States. We take this opportunity to thank the trade for their liberal patronage during the year 1899, which has had much to do in making our house one of the most successful in the jewelry industry. We shall ever strive to please and accommodate our customers in every way. "Promptness" will be our motto from this time forward, and we shall endeavor to ship all duplicate orders within twenty-four and not to exceed thirty-six hours after they reach our factory. Our large space and modern equipment will enable us to accomplish this. We have just one word to say to the retail trade: "Remember that no chain in the world stands higher and gives better satisfaction than our make, and that they are exactly as we represent them. We have three grades, ten, fifteen and twenty year, and every purchaser will get value received. Ask your jobber for these goods, for your stock will not be complete without them."



S. O. BIGNEY & CO., Attleboro, Mass.



**"THE PARAGON OF JEWELRY AUCTIONEERS."**

*Keystone, May, 1899.*

"Greatest auctioneer in the United States."

*—Commercial, Vincennes, Ind.*

"Has captivated bargain seekers all over the country."

*—St. Joseph Daily Herald.*

"As an auctioneer he is a 'cracker-jack.'"

*—Fort Smith, Ark., Times.*

**S. MARTIN,**

**JEWELRY AUCTIONEER,**

784 FIRST ST., - - MILWAUKEE, WIS.

**G. F. WADSWORTH,**

**Watch Case Manufacturer**

**AND REPAIRER.**

Everything in the line of Watch Case Repairing. Old English and Swiss Cases changed to take American Stem-wind Movements a specialty.

**OLD CASES MADE NEW. CHARGES REASONABLE.**

Silversmiths' Building, CHICAGO.

**DON'T FORGET THE JEWELERS' CIRCULAR PUBLISHING CO.'S BOOK LIST when in want of any technical work in the Jewelry or Kindred Trades.**

**San Francisco.**

**THE HOLIDAY TRADE.**

Christmas is passed and wholesalers and retailers alike are taking a little rest. It is the general verdict that the holiday season just passed has been one of the best in the history of the city. It began early and increased steadily clear up till Christmas Day. In the State at large the same condition seems to have prevailed. Only in one spot—the extreme south—has there been any disappointment. The jobbers did a good business in Los Angeles and San Diego early in the season, but the hopes of the retail trade there do not seem to have been realized.

H. Frederick is now on a trip through Nevada.

John Kite has removed to Chico, Cal., where he has taken a position with E. Meybem.

John Rasmussen, a well known jeweler of this city, died suddenly at his residence in this city on Dec. 20. The cause of death is said to have been heart disease.

Harry B. Smith, the former salesman of Shreve & Co., who pleaded guilty to petty larceny, was last week sentenced to six months in the county jail.

Jewelry exports from San Francisco still continue. The Japanese steamer *America Maru*, which cleared from this port a few

**ABSOLUTELY THE BEST.**



Manufactured by **F. H. NOBLE & CO.,**

103 State St., Chicago.

Sold by all Jobbers.

days ago, carried valuable shipments of jewelry for Japan, China and Manila.

James Marshall, formerly with Shreve & Co. but now in the jewelry business in Chicago, and W. Marshall, formerly with Shreve & Co. but now engaged at the Spreckles Sugar Refinery, at Salinas, Cal., spent Christmas with their brother, Allan Marshall, manager of the watch department at Lundberg & Lee's store.

**Big Watch Companies Raise Price of Movements.**

Announcements were made to the jobbing trade yesterday by the Elgin National Watch Co. and the American Waltham Watch Co. that the discounts to jobbers upon movements had been readjusted. This readjustment is, in fact, a raise in the price, although the list prices remain unchanged, the raise coming through the reduction in the discounts to the jobbers. The jobbers, it was announced, were already notifying their customers of a change in price, based on the change to them.

In speaking of this matter to a CIRCULAR reporter yesterday, a representative of one of the watch companies stated that the readjustment was due to many causes, among others the increase in the price of materials and, in fact, everything, including labor. The list prices, he said, had been changed three times during the past year, so it was deemed advisable to make a change now in the discounts.

An auctioneer who has found a permanent place in the consideration of the jewelry trade as an entirely qualified and able professional is S. Martin, 784 1st St., Milwaukee, Wis. He has had 22 years' experience and has made sales for many of the leading jewelers throughout the country, whose letters of praise and appreciation of Mr. Martin's services are, no doubt, but a just and fitting testimonial of this jewelers' auctioneer's abilities. These expressions of satisfaction are so numerous as to justify them being collected into pamphlet form. Any jeweler contemplating holding an auction sale would do well to communicate with Mr. Martin.

**COMMERCIAL LAW POINTS.**

A carrier may limit its liability by special contract.

The payment of half a debt is no consideration for release as to the remainder.

Right to rescind a contract for fraud must be exercised immediately upon its discovery.

Whether a purchase on credit by an insolvent was fraudulent depends on whether he bought without intending to pay.

A buyer's untrue statement as to his financial condition does not constitute an element of fraud where it is statement of opinion.

**Georgian STERLING SILVER.**

In Complete Table Service—



COFFEE SPOON.

French Gray Finish.

**TOWLE MANUFACTURING CO.,**  
CHICAGO. NEWBURYPORT, MASS.



**THEODORE NEUHAUS & CO.,**

Lion Building, 5th and Elm Streets, CINCINNATI, OHIO.

SPECIAL WORK TO ORDER.

**Gold and Silver Smiths. MEDALS, BADGES, SCHOOL PINS,**

Repairing and Refinishing Given Special Attention.

All Grades.



**St. Louis.**

A. Kersten has recently joined the ranks of the benedicts.

A. R. Brooks, of the Brooks Optical Co., is out of the city on a business trip.

Sam H. Bauman, of Bauman-Massa Jewelry Co., left on Jan. 2 for New York.

John C. Bensiek, father-in-law of Frank H. Niehaus, of the F. H. Niehaus & Sons Jewelry Co., and of Edward Boehmer, died on Dec. 24, aged 58 years.

Louis P. Aloe, of the A. S. Aloe Co., was unanimously renominated for president by the Merchants' League Club at a meeting held on Dec. 27, 1899.

Mermod & Jaccard Jewelry Co. have on exhibition a number of prizes manufactured by them that will be awarded at the poultry show taking place at the Exposition building, Jan. 1 to 6.

Wm. Weidlich, representative here of the New England Watch Co. and Hamilton Watch Co., is recovering from a severe attack of typhoid fever, and expects to be out within the course of two weeks.

Henry Estinghausen, of the Attleboro Jewelry Co., is now probably in Hong Kong, China. Word was received from him on Nov. 19 from Yokohama, Japan, whence he intended sailing for Manila. He is on a purely business trip, which he reports has been very successful.

Out-of-town jewelers here last week included: Jos. Knapp, of Knapp Bros., Belleville, Ill.; L. B. Trueblood, Shoals, Ind.; J. H. Booth, Alton, Ill.; Wm. Westphal, St. Charles, Mo.; J. B. Huddle, Cas-eyville, Ill.; A. Buchroeder, of Gilman &

Dorsey, Columbia, Mo.; Mr. Sheppard, of Ingersoll & Sheppard, Carbondale, Ill.

**Detroit.**

THE HOLIDAY TRADE.

A conservative estimate of the money spent in Woodward Ave. stores the week before Christmas places the sum at \$600,000. The estimate is made by a competent merchant in each different line. The share of the jewelers is \$150,000, but there are many large-sized stores on Michigan, Grand River and Gratiot Aves., besides the department stores, that are not included. The holiday season this year has broken all records since 1892. Wright, Kay & Co. had a tremendous trade in all lines, but their specialty this year was foreign novelties, bric-à-brac, etc. The demand was for the very best class of goods. Roehm & Son broke all previous records. Their watch, stationery, cut glass and optical departments show decided gains. W. A. Sturgeon & Co. report a steady demand for the best goods, especially in diamonds and jewelry. The low priced novelties so popular in recent years are still on the shelves.

R. W. Scorey has started a repair shop at 235 Grand River Ave.

Mr. Selling, of J. A. Selling & Co., has returned from a trip to New York.

R. G. Baker, Lennox, and F. N. Pauli, Pontiac, purchased goods here last week.

Charles W. Warren, who has charge of the diamond department of Wright, Kay & Co., is ill with grip and neuralgia.

Noack & Gorenflo, wholesale jewelers, received the contract for 50 clocks to be installed in new Detroit school buildings.

**Columbus, O.**

THE HOLIDAY TRADE.

Trade continued very fair through the second week of the holidays. Jewelry dealers have had a business that has never been excelled, and the

best part of it is the sales were not in silver novelties and trinkets, but in watches, diamonds and plate, goods there was profit in. In this connection a good joke is told on one firm here. In past years they have placed the case of novelties in the rear of the room and the crowd always worked back that way during the holiday season. In order to avoid this, they concluded to place this particular case well up front this time in order to keep people from going so far to the rear. In its place they put a case containing solid gold goods. What was their dismay when they saw the crowd going to the rear this year, but they were not novelties they were looking for. They went to the cases containing the valuable goods and let the cheaper variety alone. All the dealers have had the same experience. All have sold better goods and more of them than they have in many years. They expect next year to do still better.

Charles Klic and his brother Otto, who were wounded last Saturday by a man who attempted to hold them up, are improving and will not be disabled long from the shots. Knorr, the man who did the shooting, is still in prison, having failed to furnish the required bond of \$500. There was a report out that the wounded men would not appear against Knorr, but would ask that he be given his freedom, but this is a mistake. Personally they might desire to do this, because of his family, but the man is dangerous and it would not do to allow such an offense to go unpunished.

**Sheriff Closes the Business of the Wilkinson Jewelry Co.**

DENISON, Tex., Dec. 26.—The Wilkinson Jewelry Co. were closed to-day by the sheriff to satisfy the State National Bank, which has a claim of over \$4,000 pending.

1850

**"BELL-POST" BUTTONS**

1900

WILL NOT BEND OR BREAK.

CONSTRUCTION  
PROTECTED  
BY PATENT  
JUST ISSUED.

A SAVING  
IN LABOR OF  
50%.

PRICES  
REDUCED TO  
CORRESPOND.



A NEW LINE  
FOR  
A NEW YEAR.

EVERY PAIR  
GUARANTEED.

OUR  
GUARANTEE IS  
BASED ON  
50 YEARS OF  
SUCCESS.

100 NEW STYLES—SOLID GOLD—NOW READY.

JOHN T. MAURAN MFG. CO.,

New York Office:

Makers of Gold Jewelry.

3 MAIDEN LANE.

Factory: PROVIDENCE, R. I.



# A. & B.

## HEADQUARTERS

FOR

## Waltham Watches

EVERY GRADE.

## AVERY & BROWN,

68 Nassau St., New York.

### A GOOD REPUTATION

is a wonderful help in selling an article of merchandise easily and profitably. The reputation of silver-plated ware with this imprint



#### MAKES IT EASY TO SELL.

The public have learned by experience that goods bearing the "Anchor" mark are of reliable quality and that their use will prove satisfactory. The U. S. Government has designated the "Rogers Anchor Brand" as the standard of quality and durability.

Send for Catalogues.

**INTERNATIONAL SILVER CO.,**

SUCCESSOR TO

**WM. ROGERS MFG. CO.,**  
HARTFORD, CONN.

New York Warerooms: 9-11-13 Maiden Lane.

**J. R. WOOD & SONS,**  
21 MAIDEN LANE, NEW YORK.

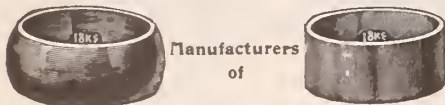

SEAMLESS PLAIN SOLID GOLD RINGS,

Diamond Engraved Stone and Child's Rings,

No Rings Stamped Different from Quality.  
Send for Catalogue and Price List.

Cash paid for old gold or silver or taken in trade. If allowance is not satisfactory, notify AT ONCE and will return in same condition as received.

DON'T FORGET THE JEWELERS' CIRCULAR PUBLISHING CO.'S BOOK LIST when in want of any technical work in the Jewelry or Kindred Trades.

### Kansas City.

#### THE HOLIDAY TRADE.

The year just closed has been the best by far for the jewelry trade in Kansas City and the tributary country, both for the retailers and the jobbers. The Summer trade was very fair, notwithstanding the extremely hot weather, while the Fall business opened up early and continued with a rush. The holiday trade was the heaviest ever handled in the city, both in number of sales and in cash value.

Among the jobbers, Woodstock, Hoefler & Co. report sales running far beyond their expectations, with the best prospects for a good Spring. J. A. Norton & Son had all the trade they could attend to and are well pleased with the year's results. Edwards & Sloane Jewelry Co. say it was like holiday season all the year through. C. J. Kiger had a better year than he ever had before, and expects even better trade this year. Similar opinions were expressed by all the other jobbers in the city.

The retailers had as prosperous a year as the jobbers and did an immense holiday trade. Jacquards were rushed in every department and had to employ more help than ever before. J. R. Mercer is smiling all over and says he feels good with himself and the world. Harry Carswell says that if he can keep this trade up for a while longer he can soon retire, as he has had the best he could ask for. C. S. Raymond Sons report themselves as very well pleased with their first holiday season in Kansas City and think their prospects here are far ahead of those in Omaha, their former location.

George A. Stevens has given a quit claim deed for \$1,000.

Roscoe C. Libby, Weir, Kan., was a visitor in town last week.

The store of A. Rohrer, Wagstaff, Kan., was destroyed by fire last week; loss about \$4,000; partly covered by insurance.

Among the industries to be added to Kansas City during the year just opened is mentioned a watch factory. But this is only among the probabilities.

C. L. Merry had over one-third increase in the holiday trade this year over previous years. Two days before Xmas he had actually sold every fancy opera glass he had in stock, and only had a few of the cheaper grades. Mr. Merry is now enlarging his present quarters, giving him room that is needed badly for his increase of business.

The calendar for 1900 presented by Stern Bros. & Co., diamond cutters and importers, 68 Nassau St., New York, is one of the prettiest and most attractive ever sent out by this house. Like its predecessors the calendar is mounted on a large, handsomely colored card, which, this time, shows a life size bust of a sweet faced young girl in a purple hood and cloak.

### Canada Notes.

#### THE HOLIDAY TRADE.

Anticipations of a busy and profitable holiday trade have been fully realized, and retailers are unanimous in stating that sales were considerably in excess of previous years, the demand for articles of a better class being especially encouraging and the public spending money more freely than in other seasons.

W. L. Wilkinson, with Ambrose Kent & Sons, Toronto, has gone to Detroit to attend the funeral of his brother-in-law, Jonathan Dunn, of that city.

E. G. Amy, Cobden, Ont., has made an assignment to Peter White, Jr., Pembroke. A meeting of creditors was called at Pembroke for Dec. 30.

Wanless & Co., Toronto, have designed a handsome emblematic pin, enameled in colors, for St. Andrew's College, the workmanship of which is much admired.

Out-of-town buyers in Toronto were few and far between during the holiday week, as usual. Among the number were N. F. Wilmot, London, and A. McDonald, Unbridge.

### Pacific Northwest.

Alden & Wheeler have rented a portion of their store building at Sumpter, Ore., to F. C. Brodie, a jeweler recently from Goldendale, Wash.

J. A. Harry, Red Lodge, Mont., last week sold his jewelry store and stock to A. H. Davis, the jeweler and optician who recently located at that place.

Johnson & Cyrus, Prineville, Ore., have moved into new quarters, which are more commodious than the former store and better suited to their stock and trade.

The Portland, Ore., jewelers all appear very well satisfied with the holiday business. It has been much better than for several years and the prospects are for continued improvement. Portland begins to realize it has to push in order to get ahead.

Heimberger & Lind, manufacturers of jewelers' findings, 158 Pine St., Providence, R. I., have presented to their patrons a small memorandum book pad bound with aluminium covers. The advertisement of the donors is stamped upon the front cover, while the back has the head and bust of a pretty girl.

## A NEW METHOD

IN MAKING

### Travelers' Watch and Ring Trays

ENABLES US TO PRODUCE THE

### STRONGEST TRAY EVER MADE.

Guaranteed for One Year.

FOR FULL INFORMATION, WRITE OR CALL.

## S. VALFER & CO.,

Manufacturers of FINE CASES AND TRAYS for Jewelry and Silverware,

33 MAIDEN LANE, NEW YORK.

**News Gleanings.**

H. Geffen has just opened a new stock of jewelry in Bland, N. M.

H. Cassell, Parkersburg, Ia., has given a chattel mortgage for \$300.

J. O. Peterson, Brookings, S. D., has given a chattel mortgage for \$118.

George R. Strode, Chandler, Okla., has given a chattel mortgage for \$112.

C. W. Chappell & Son, Eau Claire, Wis., have added a lens grinding plant to their business.

S. D. Armstrong has removed his stock of jewelry from Eagle Lake, Tex., to Palestine, Tex.

J. G. Raine has given a bill of sale for \$5,000 on his jewelry business in Cripple Creek, Col.

The Baker Jewelry Co., Horton, Kan., are reported to have given a chattel mortgage for \$1,000.

Milton E. Leavens has succeeded to the entire jewelry business of Leavens & Leithauser, Fulton, Mo.

In a destructive fire in Hastings, Minn., Dec. 25, Theodore Schaal's jewelry building was badly damaged.

H. W. Jones, a few days ago, opened a new jewelry store in Madison, Me. He comes from Freeport, Me.

C. L. Gilmour, jeweler, Greenville, Mich., keeps the steam off his store windows by using an electric fan.

Judgment has been rendered against S. Beck, of the S. Beck Jewelry Co., Dallas, Tex., for \$328, interest and costs.

W. H. Marlow, of the jewelry and furniture firm of Porter & Marlow, Moline, Kan., has sold real estate valued at \$300.

Edwin Kinsinger has been admitted to partnership in the drug and jewelry business of R. E. Baughman, Roswell, N. M.

The property occupied by J. J. Ferguson as a jewelry establishment in Alexandria, La., was sold at sheriff's sale Dec. 23.

The Baker Jewelry Co., of Horton, Kan., are reported to have brought suit against a western jewelry jobber for damages to the amount of \$5,000.

J. W. Talbot, Nevada, Mo., has just completed an auction sale, which is reported to have been very successful. J. M. Potts conducted the sale.

Martin Wold, East Grand Forks, has filed a petition in bankruptcy in the United States Court in Fergus Falls, Minn. His assets amount to \$303 and his liabilities to \$2,877.27.

Dr. Benjamin L. Babcock died recently in Traverse City, N. Y., of paralysis. He had been a helpless invalid for a number of years. He was formerly a resident of Oxford, N. Y., and was in the jewelry business for some time.

Burglars smashed the glass window of J. M. Laurence's jewelry store, Hickory, N. C., a few nights ago and entered the building. Most of the valuables had been locked in the safe. Thieves made away with about \$200 worth of jewelry.

George W. Chittenden, jeweler, Des Moines, Ia., has brought suit against Thomas J. and Carrie Young for \$40,000 for the alleged alienation of his wife's affections. The case is full of sensational charges and is said to have been hastened by Mrs. Chittenden's being about to bring suit for divorce.

A pail of gasoline became ignited at R. E. Cooper's jewelry store, Opera house block, Westfield, Mass., last Tuesday afternoon, and made things lively for a short time. The flames were put out before the department arrived. The gasoline was being used to clean a clock, and how it became ignited is not known, for there was no gas burning within 10 or a dozen feet of the pail.

Joe Jenness, Geo. Vigue and Henry Allen were up before Judge Shaw, in Waterville, Me., Dec. 26, charged with taking several watches and a few other goods from the stock of L. H. Soper & Co. The boys pleaded guilty. Judge Shaw decreed that the parents of each boy should settle satisfactorily with the firm, and that the reform school sentence be suspended for a time conditional upon the good behavior of the boys.

**HENRY C. HASKELL,**

11 Maiden Lane, N. Y.,

has a special department for Jewelry repairing of all kinds. Prompt attention. Prices right. Exclusive Design Plates sent dealers upon request.

**American Watch Case Co.**

**A.W.C.CO**

Have Merit—Superiority—Reputation.

9 to 13 Maiden Lane, New York.

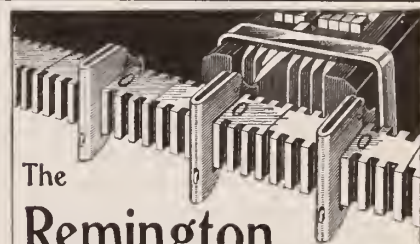

The **Remington**

Billing and Tabulating Attachment

accomplishes all kinds of Billing, Statistical, and Accounting Work on the New Models of the

**Remington Standard Typewriter**

as quickly and as accurately as ordinary typewriting is done. It automatically secures perfect perpendicular as well as horizontal alignment.



REMINGTON DEALERS EVERYWHERE SUPPLY IT.



**Eliassof Bros. & Co.,**

IMPORTERS AND JOBBERS OF

**DIAMONDS, WATCHES, JEWELRY,**

9-11-13 Maiden Lane,

NEW YORK.

Materials, Tools and Optical Goods.

ALBANY OFFICE: 62 & 64 STATE STREET.

WATCHES OF PRECISION.

**MATHEY BROS., MATHEZ & CO.,**

WATCHES DEMAGNETIZED.

MANUFACTURERS AND IMPORTERS OF

Superior Plain and Complicated

**WATCHES AND MOVEMENTS.**

Small Lever Watches a Specialty.



10 SIZE MOVEMENTS.

BRASSUS, SWITZERLAND.

21 & 23 MAIDEN LANE, N. Y.

10 SIZE SPLITS.

## CONSULT

## "The New York Jeweler"

Before Buying Jewelry or Kindred Lines.

For 26 years the acknowledged authority for all that is new, artistic and beautiful in the Jewelry World.



724 Pages. Size, 9 x 13.

This profusely illustrated catalogue enables the dealer to make a better selection than the majority of travelers' stocks affords.

**S. F. MYERS CO.,**

MANUFACTURING and WHOLESALE JEWELERS

Myers Building, 48-50 Maiden Lane, New York.

Mention Dept. G 12 when sending for catalogue.

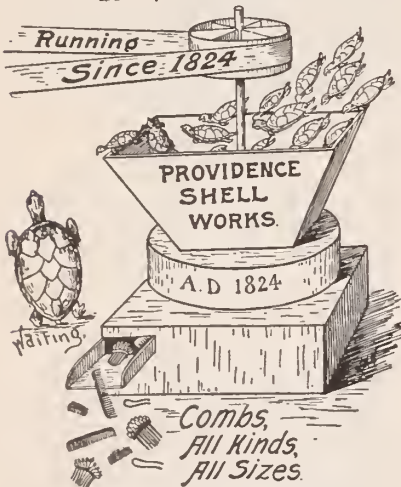
**Survival of the Fittest.**POTTER'S COMB FACTORY,  
PROVIDENCE, R. I.**We Grind for You,  
Send along your Work.**

B. L. Gates Jewelry Co., Waterloo, Ia., say there is no truth in the local report that they are going out of business.

Waggoner Watchman Clock Co., Grand Rapids, Mich., have incorporated for the manufacturing and sale of watchmen's clocks, etc. Capital, \$50,000. Incorporators: A. K. Wheeler, A. E. Waggoner, W. B. Waggoner, all of Grand Rapids.

Fire caught in the basement of T. E. Schleuder's jewelry store, Albert Lea, Minn., on the night of Dec. 26, and at one time it looked as if it would result in a severe conflagration, but with excellent work it was extinguished. There is considerable damage from the fire and smoke, but it is believed to be amply covered by insurance.

Col. E. F. Fleming, who was appointed under ex-President Cleveland as clock master of the Treasury Department, still holds that position. He has over 500 clocks in his care, and is familiarly known in department circles as "Father Time." He starts on his round of winding his family of eight day clocks on Monday and gets around to the last one on Saturday night.

Under date of Dec. 22, Samuel R. Zewtow, wholesale jeweler, Denver, Col., issued a circular announcing that in a few days he would remove to new and enlarged quarters at 1633-1639 Arapahoe St., that city, where he would occupy the second floor, expressly fitted up to meet the requirements of his increasing business. At the same time he would open an eastern office at 10 Maiden Lane, New York, to facilitate his buying.

**Lancaster, Pa.**

## THE HOLIDAY TRADE.

The retail jewelers of the city, with one accord, report the season just passed as far beyond their most sanguine expectations. The depleted stocks bear out their assertions. They report having sold more high priced goods this year than ever before.

The employees of L. C. Reisner & Co. presented to Mr. Reisner on Christmas, as tokens of their esteem, a silk hat, a purse and gloves.

Henry J. Cain, vice-president and superintendent of the Hamilton Watch Co., who was stricken with apoplexy about a week ago, is in an improved though still critical condition.

Miss Elizabeth Virginia Binkley, for a number of years a clerk in S. Kurtz Zook's store, was married on Wednesday to John W. Bush, superintendent of the Scranton School of Correspondence, this State.

William Thomson, the oldest watchmaker in the city, now in the employ of Ezra F. Bowman, was sadly bereaved on the 24th inst. by the death, in New York, of his daughter, Miss Edith E. Thomson. The young lady was a student at the Carnegie School of Music.

**Birmingham, Ala.**

## THE HOLIDAY TRADE.

The Birmingham jewelers this season have broken every previous record the town has ever made for business. "My business was twice what it was last year," said E. Lowinsohn. "I've seen nothing like it since I've been here," said Ed. Herzog at Harry Mercer's. "The best I ever saw," said E. Gluck. And so it goes. Everybody is happy at a business that was simply enormous. The trade was in higher class goods, such as diamonds and watches.

The Athens Book Co., Athens, have added jewelry to their stock.

Geo. J. Alston has added phonographs to his jewelry stock at Tuskalooza.

D. H. Lynn has opened a jewelry business at Carbon Hill, carrying stock and running a bench.

Buder Bros., Columbus, Miss., have established a sample room at Fayette, Ala., in charge of R. J. Young.

P. H. Linnehan has given \$50 to the new Hillmon Hospital about to be erected. He will also give when called on \$25 each to the Mercy Home and the United Charities.

The E. O. Zadek Jewelry Co., Mobile, last week celebrated their 33d year in Mobile. E. O. Zadek, president, has returned from New York, where he had been for several weeks seeking health. The Mobile Register pays Mr. Zadek the following compliment:

"If Major E. O. Zadek, of this city, was to die we would all say how sorry we were, and what an excellent citizen he had been. In a word, we would sing his praises, which would be listened to with sorrowful interest by his surviving relatives. It happens, however, that the major is not dead, but has come back to us very much alive, although not long ago he was so ill that his physician thought he would not recover. Well, let us join in saying what a good fellow he is and how heartily glad we are to see him once more. He might have been dead, but he is alive and is getting stronger every day; and soon he will be with us the same as before, helping to make this old world happier and this old town better to live in. Friend Zadek, *The Register* cordially welcomes you home."

**Pacific Coast Notes.**

James McLeod has opened a watchmaking business at Murphy's, Cal.

J. Amann, formerly of Oregon, has opened a jewelry store at Sisson, Cal.

C. M. Buck, who purchased the jewelry stock of F. E. Bundy, Santa Monica, Cal., has removed it to Los Angeles, Cal.

The O. E. Bell Co., Cincinnati, O., will have on the market in a few days a new ladies' chain, called "Spanish Senorita," which has three pendant sections, *à la chatelaine*. It will be one of the most attractive patterns on the market.

# The Mercantile National Bank

OF THE CITY OF NEW YORK,

BROADWAY AND DEY STREET,

Solicits Accounts from the Jewelry Trade.

**Pittsburgh.**

Samuel Harowitz was fined \$100 and costs for receiving stolen goods.

Out-of-town dealers in the city recently included the following well known jewelers: L. C. Grassell, Mahoningtown, Pa.; F. W. Laban, Steubenville, O.; John A. Stonecker, Scio, O.; John Yenny, Brad-dock, Pa.

Benjamin Lewis, the young man who stole diamonds, cheques and money from Grafner Bros., was sent to the Huntingdon Reformatory. It was the intention of the Court to sentence Lewis to the workhouse, but an effort made to have him sent elsewhere was successful, mainly on account of the fact that the valuables, with the exception of \$75 in money, were recovered.

The police department is experiencing considerable difficulty in bringing Charles Hoyt, the alleged "stall," who assisted James Reilly in the robbery of A. E. Siedle's store, back to Pittsburgh. He is under arrest at Boston. A hearing before the Governor of Massachusetts on the granting of requisition papers must be held before Hoyt will come back. He intends to fight, and has money in the bank and influential friends to support him.

**Indianapolis.**

**THE HOLIDAY TRADE.**

The year 1899 closed very successfully with the trade in Indianapolis and the State in general. The larger city dealers report the holiday trade not phenomenal, but very satisfactory. The Saturday before Christmas was all one could desire. In speaking of their trade J. E. Reagan, of Baldwin, Miller & Co., said: "The year just closing has been the most prosperous one the firm has had in its 17 years' experience; and from the present demands the Spring trade will be very large. Our customers, both large and small, report an unusually big trade and collections could not be better." Judging from the Indianapolis trade the chain manufacturers were very much "in it" this season.

H. A. Comstock spent the week between Christmas and New Year's hunting in Indiana.

The Indianapolis Jewelry Co. dissolved partnership some days ago, to reorganize about Jan. 1.

The firm of Heaton, Sims & Co. will con-

tinue business with Robert Heaton manager and William Garrison bookkeeper.

Elliot Sims has begun to buy stock for the new firm of Sims & Lauer, and expects to get on the road by the middle of January.

**Souvenirs of the Season.**

Chester Billings & Son, importers of diamonds, Maiden Lane and Nassau St., New York, have presented to the trade a neat and handy, little, pigskin card case containing their advertisement.

The always welcome annual gift to their customers from Carter, Hastings & Howe, manufacturing jewelers, 9-13 Maiden Lane, New York, has again made its appearance. This, it is needless to say, is the daily pad calendar which has been issued by this house for many years, and the calendar for 1900 is of the same character and has all the handy features of its predecessors.

Sig. Hirschberg, diamond importer, 65 John St., New York, has presented to the trade a pretty monthly calendar.

The Fred G. Sutor Co., diamond dealers, Philadelphia, Pa., and New York, are sending out a monthly calendar on a large, highly colored board, showing a pretty woman.

**A Race Horse Man's Scheme to Get Money.**

NEW ORLEANS, La., Dec. 26.—George Muller, who styles himself a race horse man, is locked up charged with grand larceny. Some days ago Muller entered the jewelry store of T. Hausmann & Sons and said that he was sent there by Joseph Traverse, jeweler, to purchase some loose diamonds. He was shown four stones by Louis Hausmann. Muller then said that he would like to see some set diamonds. Mr. Hausmann turned to get them. After some talk about the diamonds, Muller started out. Mr. Hausmann claims that he had two of the stones with him. Muller gave back one of them, but insisted that he did not have the other.

Mr. Traverse said that Muller is a stranger to him. He had one transaction with him, however. Muller disposed of a valuable diamond to Mr. Traverse.

**\$100 in Gold**

is what we offer for the best sample of engraving done on the Eaton-Engle Engraving Machine. If you've got a machine, send in your samples. If you haven't one, write and find out how easily you can get one on installments. You have time enough now to try for this prize, and your chance is as good as anyone's.

It only costs you a penny to send a postal card, and you'll get in return a fully illustrated catalogue, a sample of engraving done on the machine, and any information you may desire regarding it.

Drop us a postal card to-day.

**The Eaton & Glover Company,**  
87 NASSAU STREET, - - - NEW YORK.

OTTO K. TREIBS. PAUL E. TREIBS.

**TREIBS BROS.,**

68 Nassau St., New York.

139 Mathewson St.,  
Providence, R. I.

CUTTERS AND IMPORTERS OF

**Opals.**

F. E. TREIBS,

Oberstein, Germany.

ESTABLISHED 1842.

HERMANN TREIBS. ALBERT TREIBS.  
EMIL TREIBS.

**Vrieslander & Moreels,**  
Commission Merchants.

We buy Rough Diamonds  
for 1 per cent commission.

We cut Melées specially  
for the American market.

Best New York References.  
Correspondence Solicited.

Temporary address,  
5 Rue Van Lier,  
ANTWERP, BELGIUM.

STERLING  
SILVER  
GOODS ONLY

TRADE  
MARK

STERLING

FRANK M. WHITING & CO.  
SILVERSMITHS

NORTH ATTLEBORO  
MASS

1128 B'WAY, NEW YORK.  
220 SUTTER ST. SAN FRANCISCO.

**WATCH CASE GUARANTEES.**

THE RETAIL JEWELERS SPEAK OUT AND GIVE THEIR IDEAS ON AN IMPORTANT MATTER BEARING UPON THEIR TRADE.

[This series of letters began in issue of Nov. 15.]

It was upon the request of several responsible jewelers that THE CIRCULAR entered upon the undertaking of obtaining a consensus of opinion from the retail trade regarding the guaranteeing of gold filled watch cases, and sent to a large number of jewelers, indiscriminately, a letter of which the following is a copy:

NEW YORK, Sept. 8, 1899.

WE ARE SENDING THIS LETTER TO THE RETAIL TRADE WITH THE OBJECT OF GETTING THEIR VIEWS ON AN IMPORTANT SUBJECT, NAMELY: THE GUARANTEEING OF FILLED WATCH CASES. FROM THE RESPONSES RECEIVED MAY BE EVOLVED SOME VALUABLE SUGGESTIONS.

OF THE FOLLOWING FORMS OF GUARANTEE, WHICH DO YOU CONSIDER MOST JUST, AND WHAT ARE YOUR ARGUMENTS ON THE SUBJECT?

1. SHOULD THE MANUFACTURER GIVE A NEW CASE OF THE SAME GUARANTEE IN EXCHANGE FOR THE OLD CASE THAT HAS NOT LIVED UP TO ITS GUARANTEE?

2. SHOULD THE MANUFACTURER EXCHANGE THE CASE THAT HAS NOT LIVED UP TO ITS GUARANTEE WITH ONE OF LOWER GUARANTEE? THAT IS, IF A 20-YEAR CASE HAS BECOME DEFECTIVE AT THE END OF 10 YEARS, SHOULD IT BE REPLACED WITH A 10-YEAR CASE?

3. SHOULD THE MANUFACTURER REPAIR THE CASE AND PUT IT IN CONDITION TO OUTLIVE THE UNEXPIRED TERM, IF THE CASE SHOWS THE BASE

METAL BEFORE THE LIFE OF THE GUARANTEE HAS EXPIRED?

4. SHOULD HE GIVE A NEW CASE AND CHARGE FOR THE LENGTH OF TIME THE CASE THAT DID NOT LIVE UP TO ITS GUARANTEE HAS BEEN WORN; IN OTHER WORDS, REBATE FOR THE UNEXPIRED TERM OF GUARANTEE?

YOURS VERY TRULY,  
THE JEWELERS' CIRCULAR PUB. CO.

All those jewelers who did not receive this letter are cordially invited to send their views upon this subject, replying to the questions seriatim or collectively. Their replies will receive the same measure of consideration as those received direct from the letters themselves. The more views on this subject expressed by the trade at large the more convincing will be the conclusions reached.

[Eighth series of replies.]

LYONS, Ia., Sept. 11, 1899.

Editor of THE JEWELERS' CIRCULAR:

Our opinion as to the guarantee of a filled case is that the case should be replaced with one as good as the one originally sold, as a guarantee of good faith. If they do not, in a short time a guarantee will be no good. Yours truly,

J. H. POTTS & SONS.

DAYTON, O., Sept. 14, 1899.

Editor of THE JEWELERS' CIRCULAR:

Yours of the 8th duly received; in reply to your questions I will say, 1st, that the manufacturer should give a case of the same guarantee as old case; 2d, the case should be of the same grade and in no instance give a 10 year case, which means only five years; 3d, the case should never be repaired, as this cannot be done satisfac-

factorily; 4th, no rebate should be allowed for the unexpired time.

The manufacturers should make better cases, and could then raise the price, in place of cutting prices and making poorer cases, which they are doing right along.  
Yours respectfully,  
ALFRED MOSER.

PELLA, Ia., Sept. 12, 1899.

Editor of THE JEWELERS' CIRCULAR:

In reply to your letter Sept. 8, 1899, would say we are in favor of proposition 2, namely, to exchange case that has not lived up to its guarantee with one of lower guarantee. Yours truly,

G. A. VANDERMEULEN.

CELINA, O., Sept. 14, 1899.

Editor of THE JEWELERS' CIRCULAR:

Replying to yours of the 8th inst. regarding guarantees, it is our opinion that when a case does not come up to the guarantee the manufacturer should either repair it, if possible, or should replace it by one of the same grade. A customer would not feel satisfied to wear one of inferior quality; besides he might have to put up with a cheap gilded case to finish up the last year of a 25 year guarantee. Yours truly,

F. OLNHAUSEN & Co.

COUNCIL BLUFFS, Ia., Sept. 14, 1899.

Editor of THE JEWELERS' CIRCULAR:

We endorse No. 4.

C. B. JACQUEMIN & Co.

GRINNELL, Ia., Sept. 13, 1899.

Editor of THE JEWELERS' CIRCULAR:

In reply to your questions will say:  
No. 1. Believe this would be the most just and most satisfactory way for jeweler and customer.

No. 2. No; for a 20 year case does not wear for 10 years as a rule, and a poorer case would wear even less. So the customer would have to change again or use a worn out case.

No. 3. The case cannot be repaired satisfactorily; it would not wear nor look right.

No. 4. How could this be done? It does not seem practicable. Yours,

H. P. PROCTOR.

DAVENPORT, Ia., Sept. 13, 1899.

Editor of THE JEWELERS' CIRCULAR:

In reply to yours of Sept. 8 requesting views in regards to guaranteeing of filled watch cases, we give the following opinions: We believe that the manufacturer ought to give a new case, which is just, for a case that does not live up to the guarantee given by them; the percentage of cases returned being so small, and giving an entirely new case leaves the customer in a good frame of mind, as well as the merchant, and the trouble is settled at once.

In reply to the second, if we buy a 14 karat case, we expect to get one, and not a case that is inferior and which does not wear the time guaranteed.

We believe it good to repair the case for the customer, as it is generally so little defective that it is better to do so than to give an inferior new case. We do not think that customer ought to be charged for the time the case has been used. A guarantee must be good for the time given or it is better not to give one at all. This is our opinion. We remain,

M. E. NABSTEDT & SONS.

KNOXVILLE, Ia., Sept. 13, 1899.

Editor of THE JEWELERS' CIRCULAR:

In reply to your circular letter as regards the guarantee on filled cases would say: I think manufacturers should give a new case for the old one. They can afford



## Our New... Jewel Case



has been pronounced  
by competent judges  
the best in size, shape,  
workmanship and fitting,  
in the market.

Roy Watch Case Co.,

Makers of SOLID GOLD CASES,

21 Maiden Lane,

New York.



TRADE-MARK REGISTERED.

to, as there is not gold enough on the best of them to hurt anyone. My plan would be to make a better case and charge more for it. I believe the time has come when a first class filled case, such as we used to buy, will be in demand by all first class jewelers. I for one am ready now for them. I am glad you are stirring up this matter. Respectfully yours,

D. A. CURTIS.

LIMA, O., Sept. 14, 1899.

Editor of THE JEWELERS' CIRCULAR:

Yours of Sept. 8 at hand, and I must say your letter is of much interest to me, also the question of filled cases. Several weeks ago I sent several cases back to a manufacturer. He wrote me saying if I wanted a new case for the one sent, he would send same upon remittance of amount to cover wear of old one. No manufacturer should put a 20 year, 10 year or five year warrant in a case that he is not willing to make good. It does seem like asking a little too much when we send back a case which has worn half the time of guarantee. Yet the retail jeweler has been led to believe that the cases would outlive their warrants or new ones would be forthcoming. Let there be an understanding between manufacturer, jobber and retailer just what the maker means by a 20, 10 or five year warrant. One time a case is sent in and no complaint is made, a new one coming back very promptly. The next time one is sent in they refuse to make it good. It is this very erratic way of doing business that has made the filled watch case what it is today, causing so much dissatisfaction with the public. My opinion is the case manufacturers should put a fair warrant in their cases and live up to all they stamp within. A new case is all that will compensate a customer for his which has not worn the limit, and we, as distributing agents and consumers, must fall back on the maker for the fulfilment of the guarantee. Trusting all jewelers will give their unbiased opinion on this very unsatisfactory subject and believing your way is the best to ascertain the true state of feeling, I remain, very truly yours,

J. H. HALE.

LAFAYETTE, Ind., Sept. 15, 1899.

Editor of THE JEWELERS' CIRCULAR:

Replying to your favor of 8th inst. will say that in answer to your questions I believe it best both for manufacturer and retailer to make good the guarantee by giving a new case of same quality. To give one of lower quality or put old one in condition to last out the unexpired time or to charge for the length of time used would be to destroy confidence in the filled cases. It would be better to raise the price of cases but make the guarantee good. Truly yours,

C. H. ANKENY.

POMEROY, O., Sept. 15, 1899.

Editor of THE JEWELERS' CIRCULAR:

In reply to yours of Sept. 8 will say that there is only one way to do business and that is to do it right, and to do it right in regard to filled case guarantees would be to give a new case of the same quality and value in place of one that failed to give satisfaction. Some of the manufacturers act quite noble in this respect and replace a case without a murmur; others, again, show the wrong spirit entirely and often practice trickery. I am now speaking of my own experience. When a retailer sells a filled case to a customer under the manufacturer's guarantee the customer buys the case upon the honor of the retailer, not the manufacturer, for he does not

know the manufacturer, and when the case fails to give satisfaction he will look to the retailer for another case and not to the manufacturer. If the retailer would want to force a case of an inferior quality on his customer he would rebel and justly think that the retailer was trying to take the advantage of him. So it becomes primarily necessary to give a customer a case of the same quality and value as the original one. The maxim of old Mr. Dennison, of the Dennison Mfg. Co., comes into play in all cases, that "What is worth doing is worth doing well."

I have a case on hand now with a so-called gold filled bracelet which I sold Christmas, 1898. I got it back last

August, looking tough, brass showing all over. I sent it back and after a delay of four weeks received the same bracelet polished up and put on a new card. This is what I call trickery. I will not name the manufacturer now, but will give him a chance to redeem himself, and if he does not I will publish him surely. Very respectfully yours,

AUGUST GOESSLER.

(Series of letters to be continued.)

A judgment for \$6,000 has been rendered against the wholesale and retail jewelry firm of W. S. Shuttles & Son, Dallas, Tex.

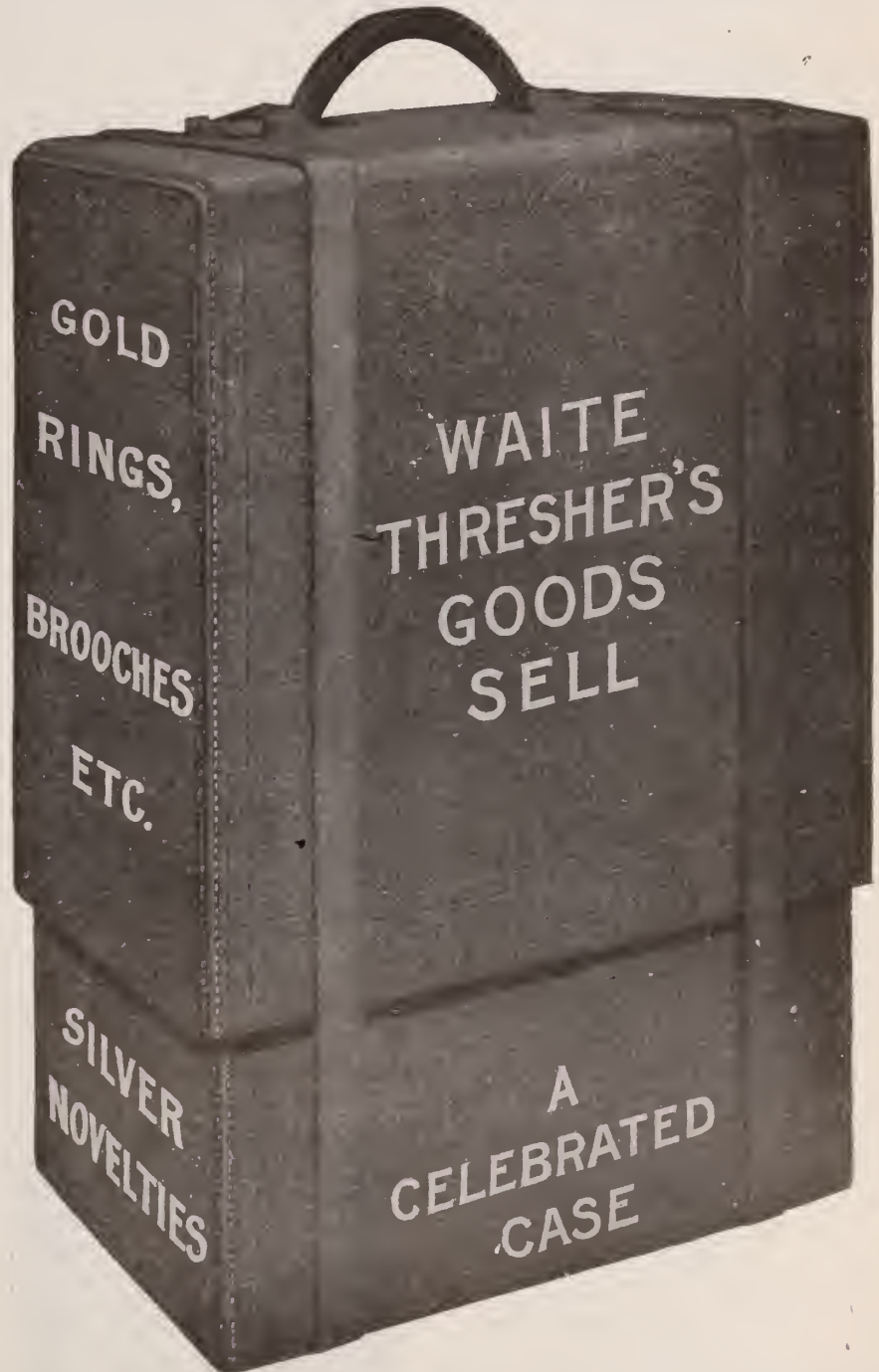

Remember that Articles Purchased from Samples Shown from the Above Celebrated Case, are Quick Sellers at Popular Prices.

NEW YORK OFFICE, 11 John Street.

**The Latest Patents.**

ISSUE OF DEC. 26, 1899.

639,862 ORNAMENTAL CLOISONNE  
WARE. THEOPHIL PFISTER, Chicago, Ill.  
Filed April 10, 1899. Serial No. 712,382. (No  
model.)



The ornamental cloisonné work having parti-  
tions formed of hollow beads threaded up and the  
intervening spaces filled with ornamental material.

639,966. ALARM-CLOCK. LOUIS E. FAVRE,  
Cormoret, Switzerland. Filed Feb. 2, 1899.  
Serial No. 704,270. (No model.)

The combination, with a watch-movement, of an  
alarm mechanism, consisting of a main gear-wheel

actuated by the mainspring, a spring-actuated  
rocking bridge, a pinion on said bridge, an alarm-  
train, means for preventing a backward movement

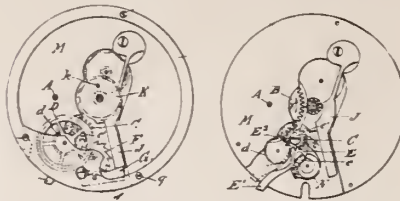

of said alarm-train, said pinion being normally in  
engagement with said gear-wheel and alarm-train,  
and a lever-arm extending from said bridge  
through the case of the watch for operating the  
bridge.

640,080. DEVICE FOR HOLDING SHIRT-  
SLEEVES OR OTHER LIKE PUR-  
POSES. ARTHUR J. BARBER, Sodus, N. Y.,  
assignor to Herman C. Ford and Alexander  
M. Lindsay, Rochester, N. Y. Filed Oct.  
4, 1899. Serial No. 732,524. (No model.)



In a sleeve-holder, a frame, a shaft mounted in  
the frame and capable of free revolution in one  
direction, and means on the shaft to engage the

sleeve and hold it while being wound about the  
shaft in the revolution of the latter.

DESIGN 32,026. CHAFING-DISH. JOHN P.  
STEPPE, New York, N. Y., assignor to S.  
Sternau & Co., same place. Filed Nov. 28,



1899. Serial No. 738,598. Term of patent 3 1/2  
years.

DESIGN 32,035. METAL STOCK. CHARLES  
GRAFF, New York, N. Y., assignor to the



Graff, Washbourne & Dunn, same place.  
Filed Dec. 1, 1899. Serial No. 738,917. Term  
of patent 3 1/2 years.

**W. C. A. WESTPHAL,  
WATCHMAKER,**

41 Malden Lane, NEW YORK.

Established 1892. Telephone, 3684 Cortlandt.

Estimates, Repairing. Adjusting of Chronometers, all  
Complicated Watches and Fine Time Pieces.

**DEMAGNETIZING.**

Watches made Non-Magnetic.

Fine Wheel and Pinion Cutting

**JULES JÜRGENSEN,  
COPENHAGEN,**

Plain and Complicated **WATCHES AND CHRONOMETERS,**

Are the leading production of their kind in the world.

SOLE AGENTS

**Schulz & Rudolph,**

*Importers and Cutters of Diamonds  
and Other Precious Stones.....*

28 JOHN and 65 NASSAU ST., NEW YORK.

**EXPIRED PATENTS.**

[Recently expired patents of interest to the jew-  
elry trade. Reported especially for THE JEWELERS'  
CIRCULAR by R. W. Bishop, Patent Attorney, 728  
Fifth St., N. E., Washington, D. C., who will  
furnish complete copies of patents at the rate of  
10 cents each.]

Issued Dec. 26, 1882.

269,588. WATCH-REGULATOR. J. C. LAND-  
MANN, Dutch Flat, Cal.

269,670. WATCH-REGULATOR. C. M. HOFF-  
MAN, White River Junction, Vt.

269,726. MANUFACTURE OF SPOONS AND  
FORKS. JOSEPH SHERIDAN, Jersey City,  
N. J.

269,772. COMPOSITION FOR CLEANING  
AND POLISHING METALS. B. G. SEE-  
BACH, Peru, Ill.

**THE TRUE BLUE**

Beaded Label Watch Glasses,

MADE IN

**FRANCE.**

ASK YOUR JOBBER FOR THEM.

**SUSSFELD, LORSCH & CO.,**

21 Rue de L'Echiquier, PARIS.

LORSCH BUILDING,

37 & 39 Maiden Lane, NEW YORK.



**WATCH GLASSES**

BEAR THE  
BEADED LABEL.

BEWARE OF  
IMITATIONS.

THE GENUINE  
ARE LABELED



**FRANCE.**





## PRACTICAL COURSE IN ADJUSTING.

### COMPRISING

*a review of the laws governing the motion of the balance and balance spring in watches and chronometers, and application of the principles deduced therefrom in the correction of variations of rate arising from want of isochronism, change of position and variation of temperature.*

### ELUCIDATED AND DEMONSTRATED BY

*original experimental researches in the actual problem, never before published, showing the causes that are operative in the variation of rate and leading to correct remedies.*

BY THEO. GRIBI.

Copyright by Theo. Gribi; assigned to THE JEWELERS' CIRCULAR PUB. CO.

[COMMENCED IN ISSUE OF FEB. 1, 1899. PART XXIV.]

## CHAPTER IV.

(Continuation of Mechanical Effects.)

To supplement the good office of a hook, a little attention to the end of the spring, in which the hole is made, is necessary. First: do not blue the end of the spring further back than necessary; second, punch the hole as close to the hard part as possible; third, leave from one-half to a full centimeter of the spring beyond

FIG. 30.

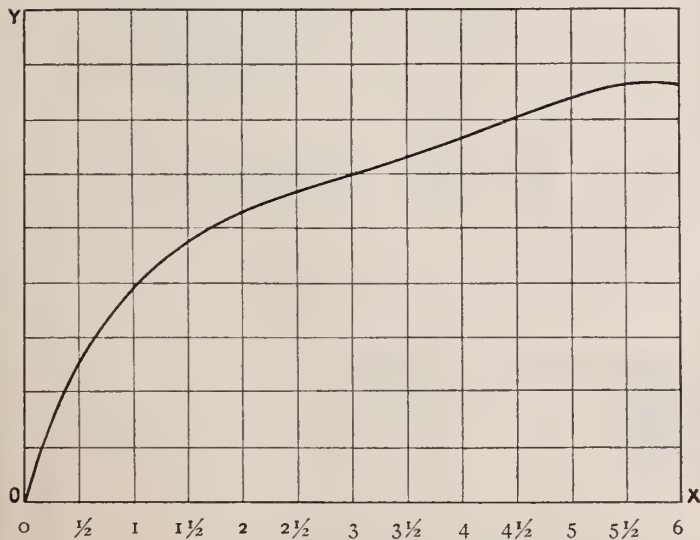

the hole, and do not make this any thinner by stoning or filing it tapering, more than what is necessary to remove the burr. This end will act as a "brace" against the wall of the barrel when the spring is under tension from winding, and tend to make it hug the wall closer. To insure its catching easily when the spring is put in

this end should be slightly curved, to conform to the circle of the barrel wall. The hook should be only a trifle higher than the thickness of the spring.

There are still other points to be considered in a spring if we want to obtain the best development of its force. In the curve, Fig. 30, we have a graphic representation of the development of the force of a mainspring, from the moment we commence to wind it until it is fully wound, the intersections on the horizontal line  $ox$  representing half-turns of the barrel arbor, and those of the vertical line  $oy$  units of force as measured by weights. If the force were a constant one it would produce a horizontal straight line. The deviation, therefore, of the curve from such a line measures its variation. The curve is the projection of the force of one of the springs actually tested as above described, and it is one of the best ones. We see that the force increases very rapidly for the first and second half-turns, and even up to the third half-turn. From there on the increase is less rapid and more uniform until we reach the eleventh half-turn, when it slightly diminishes. Other springs I have tested diminish more rapidly after the eleventh half-turn, and even before that, and develop more irregularly during the earlier stages. We see, then, that the development of force we can obtain from the best springs is none too good. Bearing this in mind, it behooves us to utilize if we can only that portion of the force which is the most uniform, and that is the portion developed between the third and eleventh half-turns, which, thanks to the "stop-work," we are able to do. If we set the latter so that one and a half turns of the arbor remain when it is "down," we will eliminate the two extremes of the force, the stop-work permitting of four turns winding only. This, however, necessitates that the spring, without the stop-work, should give not less than six full turns. It would be still better if we could obtain seven turns, for the greater the number of turns a spring winds, the less rapid and generally more uniform, if it is a good one, is the development of its force. We are, however, limited by other conditions: first, the amount of force required to produce sufficient motion in the balance, and, second, whatever the length and thickness of a spring may be, it will give the maximum number of turns to wind only when the area of the empty space in the barrel is equal to the area the spring occupies. To increase the number of turns, we would have to increase the length of the spring, other things being right; but the last-named condition forbids this, unless we can, at the same time, reduce its thickness. It is, therefore, plainly visible how important it is to construct watches so that the least motive power is required to produce a given motion of the balance. The thinner a spring the longer it can be, and the greater the number of turns to the barrel, and consequently the more uniform the development of its force.

(To be continued.)

Perfect Hanging of Regulators, Etc.

EVERY horologist knows how necessary it is for a regulator or any other wall clock to have an accurate and invariable hanging position. That the method of securing the hanging so far employed does not

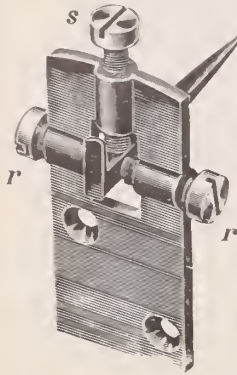

CUT 1.

suffice in many cases, is proved by the deep (often several inches long) curved small furrows scraped into the walls of the sidescrews, which are a proof of repeated moving of the regulator. Horologists will, therefore, be interested in the new device for hanging regula-

tors and wall clocks, illustrated in diagrams herewith. The German patents are Nos. 103,533, 105,247. The device performs its purpose so well that clocks in which it is employed hang as firmly as if they were fixed to the wall. A complete arrangement is composed of the hanging ear (cut 1) and either two sidescrews, one of which is shown in cut 3, or the removable scale (cut 2). Furthermore, wall clocks can be fastened firmly without any sidescrews by using only two hanging ears (cut 1). The way to arrange this is to fasten at the back side of the clock case, not too far apart from

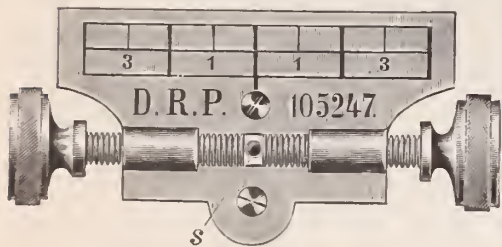

CUT 2.

each other, two of these hanging ears, each of which, as shown in cut 1, is provided with three screws. After this is done, two suitable hooks are fastened into the wall and the clock is hung upon them. To govern the fall of the pendulum, the screw *s* of one or the other ear has to be screwed up or down until the pendulum swings

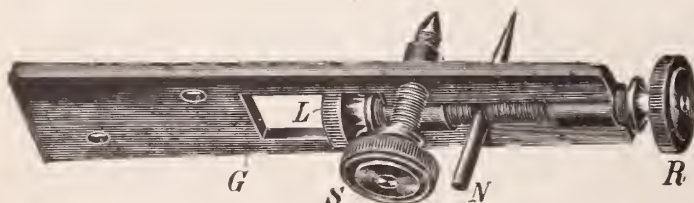

CUT 3.

correctly; that is until the fall is correct. After this is done, it is only necessary to turn the sidescrews of the ear. By this, the hooks are put in firmly and the clock is absolutely protected from being moved out of its place. Instead of using the four-

cornered hooks shown, round ones may be used with still greater advantage, because the two screws *rr* will meet them from below and press them against the end of screw *s*.

Generally, however, only one hanging ear is used and two of the sidescrews (cut 3); the latter have to be screwed, as is always done, to the lower part of the clock case. After this, the clock has to be hung upon the hook; the screws, however, need not yet be tightened. Cut 3 shows that one of the sidescrews has two horizontal movable binding screws, *L* and *R*. A steel pin must be put between the ends of the screws. When the clock is hanging straight and when the fall of the pendulum is nearly correct, the steel pins are driven

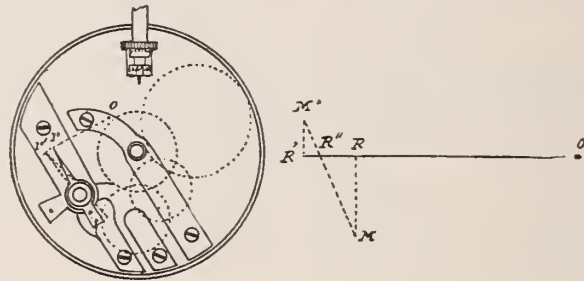

PLAN FOR ADJUSTING WATCHES.

into the wall with a hammer. After this is done, the fall of the pendulum must be regulated exactly by turning the screw *L* and *R* and, last, every side and hook screw must be screwed tightly.

To hang a clock perpendicularly, even if the wall should lean over, the ordinary sidescrew can be used.

The third art of hanging is applicable principally for exposed pendulum clocks, but may just as well be used for ordinary regulators. An ear (cut 1) is screwed to the clock case, and at the place where generally the ordinary scale is placed, the scale with apertures, as shown in cut 2, is fastened. Through the back of the case a small opening has to be cut, and when the clock hangs correctly the small steel pin *s* is driven into the wall. After this, the swing has to be regulated, and the pin as well as the hook has to be screwed tight. The patent for this device for the United States is for sale. Parties interested should apply to F. Acht, Bremen, Germany, Bischof Str., 13.

**Palladiumizing Watch Movements.**—Palladium is successfully employed for coating parts of timepieces and other pieces of metals to preserve them against oxida-

tion. To prepare a palladium bath use the following ingredients: Chloride of palladium, 10 grammes; phosphate of ammonia, 100 grammes; phosphate of soda, 300 grammes; benzoic acid, 8 grammes; water, 2 liters.

Plan for Adjusting Watches.

[Translated from the *Revue Chronometrique*.]

CHAFING for a long time under the tedious tentative efforts necessary for adjusting a watch, I bethought myself of the possibility of applying the methods of successive approximation which are so useful in the solution of complicated equations. The problem may be solved by mathematical calculation, or by a diagram. I prefer the latter because it presents to the eyes the progress of the corrections, so that large errors, due to inattention, are avoided. Besides, the drawing made for a first adjustment may serve for a second. There are two parts to the problem:

1. To determine precisely by means of a measure, readily taken, the position of the index corresponding to a known daily rate of going, so as to be able, on displacing it, to bring it back to the precise point.

2. Known the diurnal rate (the gain or loss in 24 hours) corresponding to the position of the index, to determine the exact point where it ought to be placed to offset the deviation. In this way the different causes of variation (the state of tension of the spring, influence of temperature, etc.), compensating each other in 24 hours, not taking into account accidental deviations, it will not be necessary to set the timepiece so often.

1. The first object is accomplished by making a fine point *r* on the extremity of the index and a point *o* on one of the bridges of the watch in a tangential line to the curve described by the index. The point *o* serves as a starting point for the measures of length; the distance *ro* is arbitrary.

The majority of watches having a second hand, it is easy to ascertain the diurnal rate nearly to a second, even if the circle is badly centered, by watching a given point reached successively by the hand. For other watches an index on the third wheel will supply the absence of the second hand.

2. To determine the point for the rate, by the graphic method, a line, *OR*, is drawn on quadrillé paper\*, from any point, to represent in extent and direction the distance, *or*, on the watch.

Below the point, *R*, if the watch loses, and above it if it gains, the ordinate, *RM*, is drawn at right angles to *OR*, of which the length represents, according to a certain scale, the daily rate corresponding to the position, *r*, of the index. Then the index is moved so as to change the rate and

\*Paper marked off into squares.

the line on the quadrillé paper is extended from  $O$  to  $R'$ , representing the distance,  $or$ , taken on the watch. Finally the ordinate,  $R' M'$ , is drawn on the same scale to represent the new rate.

To ascertain the position to give to the index it is sufficient to join by a straight line the extremities,  $M$  and  $M'$ , of the two ordinates representing the rates of going. The point,  $R''$ , where the line,  $M M'$ , cuts the horizontal  $OR$ , is the point sought for. There is the advantage that in one case the timepiece gains, and in the other it loses, avoiding the extrapolation, which gives less precise results. If the index carried to the point  $R'$  does not exactly compensate for the error, a second drawing will give the slight correction to make.

If, at a later period, in consequence of the change of season or the thickening of the oils, the rate of the watch should deviate, the process will not be lost, for if the diagram has been preserved, it will be sufficient to draw from the point representing the new rate a parallel to the old line,  $M M'$ , to fix a point which will certainly be very near what is needed to compensate for the deviation and allow of a second closer approximation.

As the changes of position to be made and measured are very slight, the most convenient instrument to use in the drawing is, in my opinion, reducing compasses in the form of an X, which anyone can make. A short branch will serve for the

measures on the watch, and a long one for the drawing on the paper. If the long branches are 10 times longer than the short, and the distances on the paper are given to the tenth of a millimeter they will represent one hundredth of a millimeter at the extremity of the index. In the watch I have used for my experiments one hundredth of a millimeter about corresponds to the rate of a second a day.

**An Address with Details.**

“**A** MERICA is a good country,” wrote a Hungarian watchmaker to a friend at his birthplace. “I have only been six months here, yet I have established myself in business. You will find my address on the card enclosed herein.”

A few weeks later the Hungarian received a letter, whose address covered the entire envelope. It read as follows: “Sigmund Barnay, dealer in watches, clocks, jewelry; watches repaired and made better than new. Good prices for old gold. Jewelry appraised almost for nothing. Diamonds set. A large assortment of watch chains, finer than gold ones. Weekly instalments taken. No. — Avenue B, in the middle of the block.”—*New York Commercial Advertiser.*

J. H. Gordon has removed his entire stock of jewelry from Mount Vernon, Tex., to Cooper, Tex.

**Workshop Notes.**

**Hard Solder for Enameling.**—This is suitable for pieces consisting of 20 karat or still finer gold and requiring a solder difficult of fusion, owing to the high temperature in enameling. Gold 37, silver 9; or gold (18 karats) 16 parts, silver 3 parts, copper 1 part.

**Artificial Polishing Agent.**—To cut and polish hard substances such as glass, steel, porcelain, etc., a chamotte preparation has been patented in Austria, in the production of which the chamotte earth is transformed with water into a pasty mass, then dried and fired at 1200-1300° Celsius. The product thus obtained shows 8-9° of hardness; hence resembles emery. If the chamotte does not melt at the above temperature it must be softened with about 10 per cent of feldspar or 2 per cent of quick lime. After the baking the mass is finely ground and carefully sifted through fine sieves. The powder can be employed for the production of grind stones and polishing stones by mixing 40 parts of it with 45 parts of chamotte earth, and 15 parts of emery, making a paste of it with water, which paste is pressed in moulds and dried at about 800° C. This polishing material is just as hard as Naxos emery and only costs about one-half as much. Its polishing qualities are greater; it withstands wear better, and does not soften hard steel.—*Journal der Goldschmiedekunst.*



**WHY**

take chances on selling watch cases you are not sure of when you can buy

**Crown 14 k. and Lion 10 k.**

gold-filled cases for the same money?

**THE GUARANTEE**

back of them is as good as a government bond.

**EVERY LEADING JOBBER**

carries them in stock.

**CROWN 14 K  
FILLED CASES**



**GUARANTEED  
FOR  
25 YEARS**

# KETCHAM & McDOUGALL,

MANUFACTURERS OF

## GOLD AND SILVER THIMBLES

ESTABLISHED 1832.



TRADE-MARK.

And the improved

### Automatic Eye-Glass Reel.

37 MAIDEN LANE,

NEW YORK.



No. 149



Pat'd Nov. 30, '94

SEND FOR  
CATALOGUE C.

## SOUVENIR SPOONS

We are up to the cash buyer. If you are a cash buyer, you must have our special circular on souvenir coffee spoons for cash buyers. We won't give you time, but we will give you price. No jeweler can afford to be without this circular, nor neglect to give us a chance to quote prices in the way of souvenir spoons or souvenir novelties. We have everything in this line.

**SIMMONS & PAYE,**  
"The Souvenir House,"  
129 Eddy Street, Providence, R. I.

## DR. KNOWLES'

...PRIVATE COURSE IN...

# Optometry.

SPECIAL RATES IN THE  
CORRESPONDENCE DEPARTMENT.

### "EYE DEFECTS,"

A New Book, in cloth, Price, \$1.00.

For terms and important particulars, write to  
**R. H. KNOWLES, M. D.,**  
36 John Street, New York.

## CLYDE LINE

### To FLORIDA

ONLY DIRECT WATER ROUTE BETWEEN  
**NEW YORK, CHARLESTON & JACKSONVILLE**  
WITHOUT CHANGE

SUPERB PASSENGER SERVICE	SAILING FROM PIER 45 N. R. NEW YORK	THREE SAILINGS WEEKLY
--------------------------------	---	-----------------------------

Wm. P. CLYDE & CO., General Agents.  
Theo. G. Eber, TRAFFIC MANAGER. 5 BOWLING GREEN, NEW YORK

**PHILA.**  
NEW  
YORK  
CHICAGO

SILVERSMITHS,  
JEWELERS.

MAKERS OF GOLD AND SILVER THIMBLES.

**FERD. FUCHS & BROS.,**  
**SILVERSMITHS,**  
MAKERS OF STERLING SILVERWARE,  
34 East 29th St., - New York.

**WOOD & HUGHES,**  
Sterling Silverware Manufacturers,  
FINE PLATED WARE,  
No. 24 John Street, - New York.

**DEITSCH BROS.,**  
14 East 17th St.,  
New York.

LEATHER.                      SHELL,  
EBONY,                              IVORY.

**JACOT & SON, IMPORTERS.**  
**STELLA AND  
IDEAL  
MUSIC BOXES.**  
39 UNION SQUARE, - N. Y.

**THE LEDOS MFG. CO.,**  
MANUFACTURERS OF  
**Watch Case Materials,**  
Crowns, Pendants, Bows, Solders,  
Springs, Findings, Etc.,  
34-36 PEARL ST., NEWARK, N. J.

**PATEK, PHILIPPE & CO.,** GENEVA, SWITZERLAND,  
MAKERS IN THE HIGHEST QUALITY OF  
**Fine, Plain, Complicated  
And Decorated Watches**  
IN 15 DIFFERENT SIZES. INTERCHANGEABLE PARTS.  
NEW YORK OFFICE, 68 NASSAU ST.      ALFRED G. STEIN, Representative.

**WM. SMITH & CO.,** GILL BLDG., 9-13 MAIDEN LANE, N. Y.  
61 PECK ST., PROVIDENCE, R. I.

ESTABLISHED 1854.      MANUFACTURED BY 07

**Gold, Silver and Rolled Plate Chains and Jewelry.**  
Novelties in Gold and Silver Bracelets. Also a large line of Chain Trimmings.

**ESSER & BARRY,** Largest Manufacturers of  
... Cheap and Medium Priced  
**IMITATION DIAMOND JEWELRY**  
IN AMERICA.

Write us for samples of almost anything with an Imitation Diamond in it.  
MAIN OFFICE AND FACTORY, 101 SABIN ST., PROVIDENCE, R. I.



## THE RAMBLER'S NOTES.

WHAT THE RAMBLER SAW AND HEARD AMONG THE DEALERS IN ART POTTERY, CUT GLASS, BRONZES, ETC.

**POPULARIZING "ELITE" WARE.** JEWELERS who handle Bawo & Dotter's "Elite" French china will be pleased to hear of the plans adopted by this firm to more thoroughly familiarize the buying public with the name and qualities of this brand of porcelain. This plan includes a series of advertisements of "Elite" ware in one of the most widely read monthly magazines of this country, the advertisements to begin in the February issue. By this means the buying public will become acquainted with the "Elite" name and trade-mark in a way that will greatly assist the customers of this firm in marketing their purchases. A large edition of a handsomely illustrated booklet costing several thousand dollars, entitled "Limoges, its People, its China," will be distributed to consumers throughout the country upon request, and in each instance the dealer will be notified of such request. The plan is an elaborate and expensive one and is said to be the first systematic attempt on the part of manufacturers to help the retail china dealers of the United States in selling their product.

EXHIBITION OF ART GOODS

THE Exhibition Committee of the National Arts Club, New York, has arranged an exhibition of bronzes which are for the most part objects suited for the decoration of interiors, drawing rooms, parlors, the office, balconies and terraces. American bronze work and models in plaster to be cast in bronze form the bulk of the exhibition; but fine specimens of modern French, Belgian and German work are added, together with beautiful old pieces from unknown workmen of the remote past in Europe and Asia, delightful specimens of Italian and French work of the 15th and 16th centuries, and bronzes from China and Japan, of to-day as well as of former centuries. Lovers of fine bronzes will not fail to seek a chance to examine this collection by card of member. It remains open till the morning of Jan. 8.

THE RAMBLER.

Parnham Brothers, Oklahoma City, Okla., have just closed an auction sale presided over by Chas. E. Manor.

## Antique Goblets and Drinking Vessels.

[Chambers' Journal.]

MUCH of the best work of the craftsmen of former times was expended on the ornamentation of the gold and silver goblets and drinking vessels of various kinds, regarded by our ancestors as among their most precious possessions. These old "mazers" and tankards, moreover, with their humbler relatives in brown stone ware, have many an association with various phases of social life which have passed away; and the sense of an allusion in literature may often be missed without some knowledge of the curious names and shapes with which they have been endowed.

In Anglo-Saxon days, when long and deep potations were frequent, the drinking cup or horn was held in high estimation, and the old poem in "Beowulf" tells us that among the treasures of the ancient barrow guarded over by the monster Grendel is "the solid cup, the costly drinking vessel." The skull of a fallen foe was not infrequently employed for this purpose. Drinking cups are often found in Anglo-Saxon tombs, some discovered in the barrows of Kent being of glass, and made on the "tumbler" principle, so that their contents should be emptied at one draught.

One of the earliest vessels which have come down to us is the celebrated Horn of Ulphus, made of an elephant's tusk, and dating from a period shortly before the Conquest. This horn—now in York Cathedral—is supposed to have been placed on the altar by Ulph, the son of Thorald, the lord of much land in East Yorkshire, in token that he bestowed certain lands on the church of St. Peter. Another version of the story is, that this worthy Dane, when his sons were disputing as to the succession to his estate, cut short the dispute by repairing to York Minster and there draining the horn before the high altar as a pledge and evidence of the gift of all his lands and revenues to the church.

Among curious examples of drinking vessels are the Peg Tankards, one of which, made of oak, with the figures of the Twelve Apostles round the sides, was found in the ruins of Glastonbury Abbey. King Edgar, it is said, at the instigation of Dunstan, put down many ale houses, and ordained that pegs should be fastened in the drinking horns at intervals, in order that whosoever drank beyond certain of these marks at a single draught should be liable to punishment. These peg tankards

were divided into eight draughts by means of the pegs, and usually contained two quarts. The edict, however, does not appear to have had the intended effect, for in 1102 we find Anselm decreeing that no priest should "go to drinking bouts nor drink to pegs."

One of the earliest examples of the Mazer (called after a Norse name of the "maple") is that preserved at Herboldown Hospital, near Canterbury, which dates from the reign of Edward I. This maple-wood bowl stands on a low foot, and measures about eight inches in diameter at the upper edge. It is mounted in silver-gilt, and at the bottom contains a silver-gilt medallion representing Guy of Warwick transfixing a dragon with his lance, while a lion seems about to attack. This cup, which holds six pints of wine, was used at the yearly feast in memory of St. Nicholas. Another mazer of the time of Richard II. is of highly polished wood and has on its silver-gilt rim the following engraved exhortation:

"In the name of the Trinitie,  
Fille the kup, and drink to me."

Mazers were sometimes lined with silver and adorned with carving, after the fashion of the one alluded to by the poet Spenser in the lines:

"Then lo, Perigot! the pledge which I plight,

A mazer ywrought of the maple ware,  
Wherein is enchased many a fair sight  
Of bears and tigers that maken fierce war."

Frequently the mazer was without feet, and can hardly be distinguished from an alms dish.

Passing from these ancient vessels—mostly the property of some ecclesiastical foundation—to the more secular goblet, we find many examples of the high importance which was attached to it in the wills and bequests of early times. The standing cup in which it was customary to receive the wine from the butler's hand, after it had been duly tested or "essayed," was at times termed a "Hanap," from which the word "hamper" is supposed to be derived. Various materials were employed in the construction of the more costly vessels, such as gold, silver, the egg of the ostrich, the shell of the cocoanut, and curiously mottled woods.

(To be continued.)

Almost invisible platinum setting is employed with very fine jewels in rings, corsage ornaments, pins, etc.; the gem thus depends upon its own unadorned beauty for effectiveness.

**Jeweled Invitation to Admiral and Mrs. Dewey.**

THERE was presented to Admiral and Mrs. Dewey, a few days ago, a unique invitation to be present at the ball of the Emerald Society of Brooklyn. The invitation was in the form of an elaborate sterling silver, jeweled plate about nine

inches in diameter, a fine specimen of the silversmiths' and gem setters' handiwork. The piece, which was made by M. Straus, jeweler, 409-411 Fulton St., Brooklyn, is valued by its makers at over \$1,000. The border of the plate takes the form of a finely carved, open-work design on artistic lines, and the plate at the top bears an etched portrait of the Admiral, surrounded by a wreath set with 28 emeralds. Underneath the portrait is etched the in-

scription: "The Emerald Society, of Brooklyn, Cordially and respectfully invites Admiral and Mrs. Dewey To attend as guests of honor the sixty-second annual ball of its society in aid of the Catholic Orphans of the Borough of Brooklyn, at the Brooklyn Academy of Music on the evening of Jan. 30th. Nineteen Hundred." The Emerald Society, by whom this in-



JEWELLED, SILVER INVITATION TO ADMIRAL AND MRS. DEWEY (ABOUT 1/2 SIZE).

inches in diameter, a fine specimen of the silversmiths' and gem setters' handiwork. The piece, which was made by M. Straus, jeweler, 409-411 Fulton St., Brooklyn, is valued by its makers at over \$1,000. The border of the plate takes the form of a finely carved, open-work design on artistic lines, and the plate at the top bears an etched portrait of the Admiral, surrounded by a wreath set with 28 emeralds. Underneath the portrait is etched the in-

scription: "The Emerald Society, of Brooklyn, Cordially and respectfully invites Admiral and Mrs. Dewey To attend as guests of honor the sixty-second annual ball of its society in aid of the Catholic Orphans of the Borough of Brooklyn, at the Brooklyn Academy of Music on the evening of Jan. 30th. Nineteen Hundred." The Emerald Society, by whom this in-

As a general rule, any person may sell, or offer for sale, at any price whatsoever, goods of which he is not the owner, but which he hopes or expects to acquire.

**Melting and Casting of Aluminium.**

FOR the melting of aluminium graphite crucibles are best employed, without any flux and avoiding too high a temperature. With some care in the observation of the temperature, aluminium may also be very well fused in iron or clay crucibles. Especially as regards the latter, overheating should be avoided, as the aluminium is liable to become silicious. Crucibles lined with tarred coal or with argillaceous earth are the best. Larger quantities may possibly be fused in the reverberatory furnace, and in this case the furnace would also have to be lined with coal or indifferent oxides. Fuel:—Wood or gas firing. The heat in fusing aluminium need only be carried to dark redness. The casting mould should consist of sand, which stands well, is loosely rammed and not dried too sharply. Chilled moulds should be well prewarmed. Powdering with graphite should be avoided. The shrinkage of aluminium is very great (1.8 per cent), and should always be considered. If pieces cast in sand are to possess the pretty, silvery white color of the pure metal the redness should not be too strong, otherwise the pieces are apt to become discolored. Stir the liquid metal well, change the stirring rod at red heat and keep back the froth. Waste, 2—6 per cent, or sometimes more for small pieces. If a flux is to be employed cooking salt or cryolite is recommendable, but it is preferable not to use any.

The china at Windsor Castle almost rivals the plate in its beauty and costliness. Of course, such plates as those with paintings of the heads of King Charles's beauties are priceless in value, but there are many other sets of historic interest and beauty. One dinner service, we are told, has been in use for 18 years, and during that time only two plates have been broken, curiously enough one at each Jubilee.

The window displays this year perhaps exceeded those of any previous year in artistic effect. Oskamp, Nolting & Co., Cincinnati, O., spared no expense to fit up their large windows in gorgeous splendor. The two Vine St. windows were resplendent in color and fine goods; one in blue plush and silver for silver novelties and the other in crimson and gold for the diamond novelties.

**Our Hand-made Cases**

are constructed in the old reliable way, which is a pride to the Manufacturer, Dealer and Wearer.

STAMPED.



ALL CASES BEARING THIS MARK, ARE HAND-MADE.

STAMPED.



Manufactured by

**DUBOIS WATCH CASE CO.,**

Makers of **SOLID GOLD CASES.**

21 and 23 Maiden Lane, New York.

**JULES J. LINTZ, Watch and Chronometer Maker**

FOR THE TRADE.

Two Diplomas and First Prizes for Scientific Workmanship.

108 Fulton Street, New York.

DOWNING BLDG., ROOM 1019.

Repairing of Fine and Complicated Watches Pocket and Marine Chronometers.

All kinds of New Pieces made to order and adjusted.

**H. M. RICH & CO.,**  
Jewelry - Auctioneers,  
7 and 9 Franklin St.,  
BOSTON, MASS.



Our New Samples are ready for the Spring Trade.  
"ACME"  
Lever Collar, Link and Sleeve Button.

STANDARD OF THE WORLD.

Manufactured in an Endless Variety of New and Original Designs.

We have made large additions to our already handsome and extensive lines in  
CHAINS, RINGS, LOCKETS, CHARMS, BRACELETS AND EMBLEMS.

See our line of EIFFEL PONY, FOB and DICKENS CHAINS.

NEW SAMPLES OF NOVELTIES IN Hearts, Ornaments, Medallions, Amulets and Tablets.



Drop us a postal and our salesman will call.  
We sell the talking Tr.



New York Office,  
11 John Street.

S. & B. LEDERER CO.  
FACTORY, PROVIDENCE, R. I.

Chicago Office,  
131 Wabash Avenue.

THE SWAN FOUNTAIN PEN.

Reputation World Wide.  
Made upon Distinct Principles.  
Is a Compressed Air Pump.  
Simply Wet the Insides to Provoke  
an Energy.

W. W. Stewart, Inventor and Patentee.

A variety of Styles and Prices

- 3 Sizes Safety Swans.
- 3 Sizes Self-filling Swans.
- 3 Sizes Adjustable Feed Swans.

MABIE, TODD & BARD,  
NEW YORK AND LONDON.

CROUCH & FITZGERALD,



Jewelry Trunks  
and Cases,  
161  
Broadway,  
Bet. Cortlandt and  
Liberty Sts.  
688 B'way,  
723 6th Av.  
NEW YORK.

Push—Grit—Energy.

A long time ago we concluded that the only way to succeed was  
by practicing Push, showing Grit and never diminishing Energy.  
The result is shown in our

1900 Line of Jewelers' Findings

THEY INCLUDE

TUBE SETTINGS FOR COMBS, EBONY MOUNTS, PATENT  
CLUSTER SETTINGS.

MEDALLION HEADS

FOR BROOCH PINS, BELT BUCKLES, LINK BUTTONS, ETC.

Large Scrolls for Picture Decorations and everything in  
Findings for the Manufacturer.

HEIMBERGER & LIND,

158 PINE ST., METCALF BUILDING, PROVIDENCE, R. I.

"BY USING OUR GOODS, YOUR GOODS WILL SELL."

# CHAS. F. WOOD & CO., DIAMONDS

1 MAIDEN LANE, NEW YORK.

IMPORTERS AND CUTTERS.

## DIAMONDS.

LARGE ASSORTMENTS.

DESIRABLE SIZES.

ATTRACTIVE PRICES.

**R., L. & M. FRIEDLANDER,**

30 MAIDEN LANE, N. Y.

97 HATTON GARDEN, LONDON.

## HALL CLOCKS,

*Mantel Clocks,*

*Traveling*

*Clocks,*

*Clock Sets,*

*Regulators,*

*Bronzes,*

*Vases, Ivory*

*Miniatures*

*and Art Goods.*

Fall Line Now Ready.



**Harris & Harrington,**

32 and 34 VESEY ST., NEW YORK.

Sole Agents to the Trade for J. J. Elliott & Co., London.

## BEER STEINS,

For Prizes, Club Use and Home Decoration.

75 Cents to \$4.50 Each.

**L. W. LEVY & CO.,**

Novelties and Optical Goods,

194 BROADWAY, NEW YORK.  
Successors to Levy, Dreyfus & Co.

## HOROLOGICAL DEPARTMENT,

BRADLEY POLYTECHNIC INSTITUTE,

PEORIA, ILLINOIS.

Largest and best watch school in America. We teach Watch Work, Jewelry, Engraving, Clock Work, Optics. (Formerly Parsons' Horological Institute.) Catalogue Free.



GOLD AND SILVER PENCILS,  
PENHOLDERS, &c.



**FAIRCHILD & JOHNSON CO.**

Office and Factory,  
220 FOURTH AVENUE, N. Y.

## TO BLOW EFFECTIVELY IS AN ART

which we never practice personally; but we have invented a machine which does it for us, called the

"Reichhelm Pressure Blower."

This, with Gas Furnaces and Jewelers' Tools generally, is the stock in trade of

**E. P. REICHELHM & CO.,**  
23 JOHN STREET, NEW YORK CITY.

WOOD ENGRAVINGS.



TELEPHONE, 645 JOHN.



## L. LELONG & BRO.,

Gold and Silver

Southwest Corner of  
HALSEY and MARSHALL STREETS,

**REFINERS,**

**NEWARK, N. J.**

**ASSAYERS and**

**SWEEP SMELTERS.**

**Sweepings a Specialty.**

**ALOIS KOHN & CO.,** 4 MAIDEN LANE, SOLID GOLD CHAINS,  
Near Broadway, N. Y.

We call the attention of the Trade throughout the country to our line of

## LORGNETTE AND GUARD CHAINS.

Will send Samples on Memorandum on receipt of satisfactory reference. Correspondence Solicited.

ALBERT LORSCH.

TELEPHONE CALL, 748 CORTLANDT, N. Y.

ALFRED KROWER

## ALBERT LORSCH & Co.,

LORSCH BUILDING,

37 & 39 MAIDEN LANE, N. Y.,

167 WEYBOSSET ST.,

PROVIDENCE, R. I.

IN STOCK, A LARGE ASSORTMENT OF

# PEARLS

ALL SIZES AND QUALITIES.

IMPORTERS AND CUTTERS OF DIAMONDS  
**Arnstein Bros. & Co.**  
 65 Nassau St. NEW YORK.  
 Cor. John.

DIAMONDS and Cutters.  
**L. & M. KAHN & Co.,**  
 172 Broadway,  
 Cor. Maiden Lane, N. Y.  
 DIAMONDS



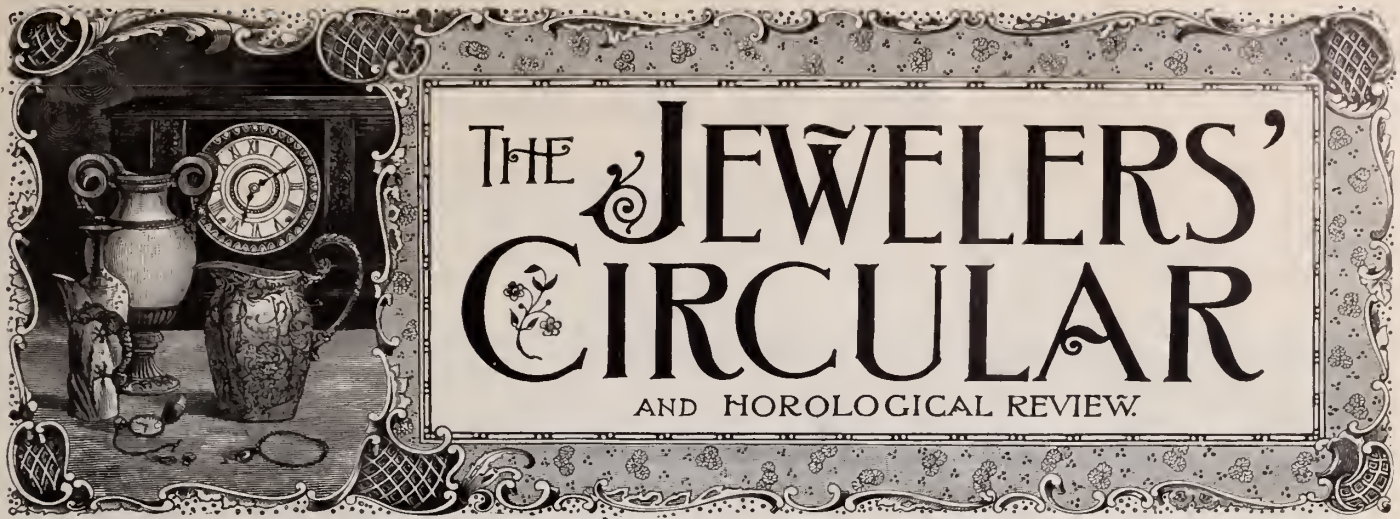

Corbin Building, 11 John St., Corner Broadway, New York.

Copyrighted by THE JEWELERS' CIRCULAR PUB. CO.

Entered at the Post Office in N. Y. as second-class matter.

VOL. XXXIX.

NEW YORK, WEDNESDAY, JANUARY 10, 1900.

No. 24.

**The Avery Spoon Collection.\***

PART VIII.

**S**WEDISH Spoons. XVIIIth Century:—  
200, spoon, small Cupid at top of handle; 201, spoon, long handle, with flat

handle, figure at top of twisted handle; 204, spoon, long handle, baluster top, coin bowl; 205, spoon, twisted stem, baluster top, coin bowl.

German and Dutch. XVIIIth and XIXth Centuries:—206, spoon, spade bowl, mermaid handle ending in ring; 207, spoon,

ure of "Warrior" handle; 212, tea strainer, chased handle and bowl, parcel gilt.

English. XVIIIth and XIXth Centuries:—213, tea strainer spoon ("Mote Skimmer"), pointed stem; 214, tea strainer spoon, gilt ("Mote Skimmer"), twisted and pointed stem; 215, tea strainer spoon ("Mote Skim-

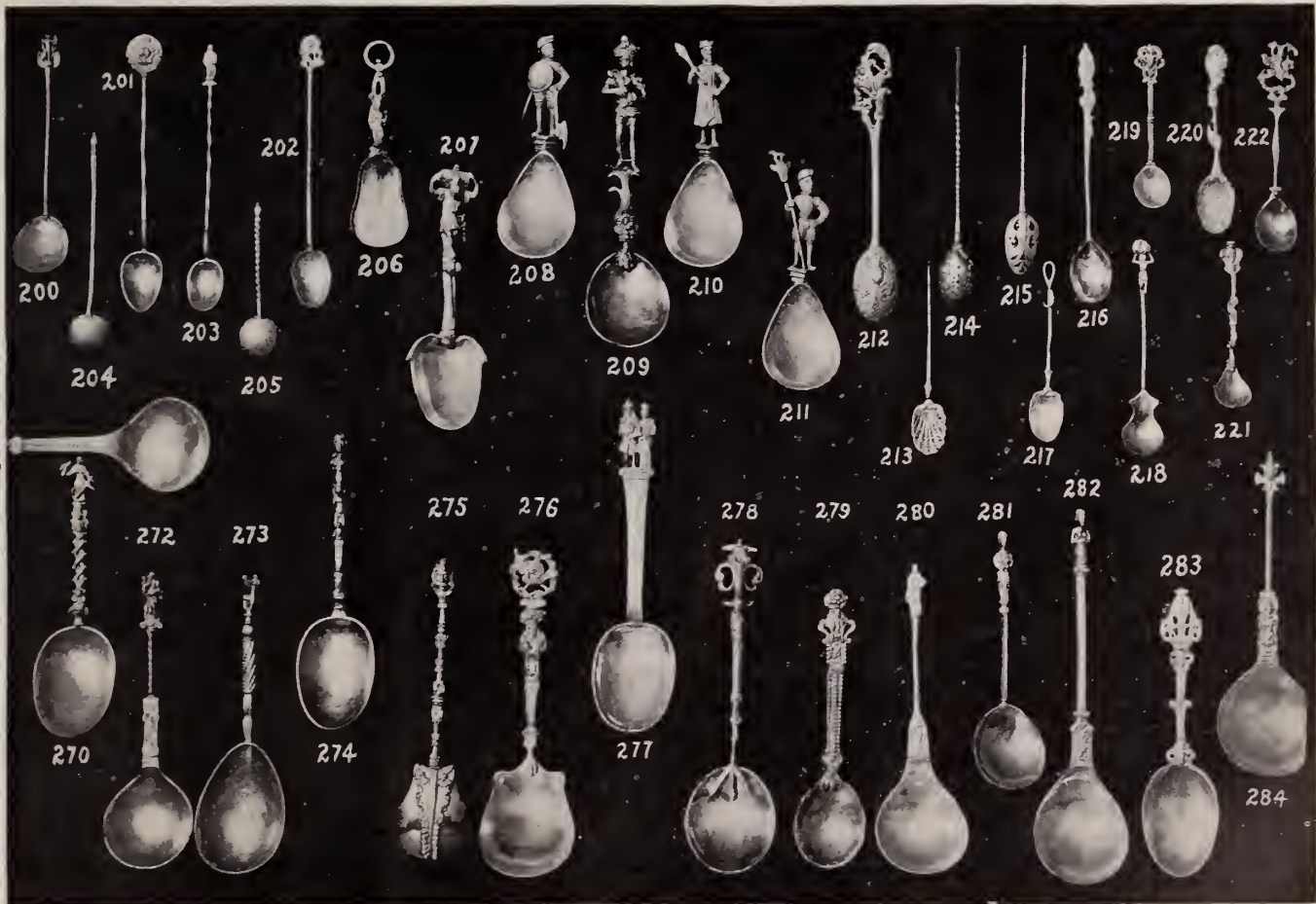

THE AVERY COLLECTION OF SPOONS AT THE METROPOLITAN MUSEUM OF ART. GROUP VIII.

From photographs on sale at The Metropolitan Museum of Art—Regrouped and Engraved by THE JEWELERS' CIRCULAR.

rose at top; 202, spoon, long handle, with rose and leaves at top; 203, spoon, long

\*This series of interesting articles was unavoidably interrupted by circumstances that need not be dilated upon, but we are now in a position to resume it, the part here printed and a succeeding part terminating the series.

galley slave handle, described by Thackeray in the "Cornhill Magazine," 1860 ("Roundabout Papers"); 208, spoon, figure of "Warrior" handle; 209, spoon, figure of "Amazon" handle, gilt; 210, spoon, figure with Mace handle; 211, spoon, fig-

mer"), plain and pointed stem; 216, tea strainer spoon, chased handle, parcel gilt; 217, tea spoon, twisted handle, shell bowl.

German and Dutch. XVIIIth and XIXth Centuries:—218, salt spoon, figure bearing nut at top of handle; 219, salt spoon, mask

# Now Is The Time

to place orders for the Spring season's goods. Our lines are better and larger than ever, and include all that is desirable to complete the stock of a modern, up-to-date jewelry store. The *quality* is the *highest*, the *styles* are the *best*, and the goods are made expressly for the regular, all-the-year jeweler.

Rolled Gold Plate and Gold-Filled CHAINS, BRACELETS, LOCKETS, CHARMS, PINS, EARRINGS, SILK RIBBON CHAINS, CHAIN MOUNTINGS, DUMBBELL BUTTONS, BROOCHES and BELT BUCKLES.



Our STERLING SILVER TOILET and MANICURE ARTICLES in the Washington, Jefferson, Victoria and American Beauty patterns are always in stock and can be matched or duplicated at any time.

**THEODORE W. FOSTER & BRO. CO.,** 100 RICHMOND ST., PROVIDENCE, R.I.  
Successors to FOSTER & BAILEY.

Established 1879. Manufacturer of

**LOUIS W. HRABA,**  **Fine Leather Goods**

29 East 19th St., New York. Exclusively for the Jewelry Trade.

**THE BASSETT JEWELRY CO.,**  
Fine Gold-Filled Chains,  
Lockets and Gold Jewelry,  
PROVIDENCE, R. I.

**AIKIN, LAMBERT & CO.,**  
MANUFACTURERS OF  
FINE GOLD PENS, HOLDERS, PENCILS,  
TOOTH PICKS and NOVELTIES.

PAUL E. WIRT FOUNTAIN PENS, at new and lower prices . . .  
MERCANTILE FOUNTAIN PENS, guaranteed to give satisfaction.

Catalogues with terms and discounts furnished to the trade.

**BRANCH, 103 STATE STREET, - - - CHICAGO.**

**AIKIN-LAMBERT JEWELRY CO.,**  
IMPORTERS OF  
**DIAMONDS.**  
JOBBER IN  
**WATCHES, JEWELRY, CHAINS,  
NOVELTIES, ETC.**

**LATEST DESIGNS. LOWEST PRICES.**

**19 MAIDEN LANE, NEW YORK.**

# A Prosperous Holiday Trade,

we hope, was your good fortune to experience.

The time consumed in the salesroom during that interval had a natural tendency to cause an accumulation of work, and possibly you ran short of material beforehand, did not have the time to order and do not now have sufficient supplies for your future requirements. If these were the conditions, we should like and hope that you will not overlook the fact that we are able to help you out.

We increased our stock considerably during December, our dull season, believing that there would be more than a normal demand later on, and we are now fully prepared to cope with all emergencies that may arise and to replenish your stock in all departments.

Our equipment is modern and complete, facilities of the highest order, and our promptness all that could be desired. On these good points we base our past success.

We are grateful for your former favors and shall strive to merit a continuance of your appreciated patronage by rendering the best possible service.

In conclusion, we extend to you our best wishes for a Happy and Prosperous New Year.

## L. C. REISNER & CO.

Manufacturing Jobbers, Importers and Exporters,  
Watch Materials, Tools and Supplies,

Jewelry Repairers for the Trade.

LANCASTER, PA.

OPEN YOUR CAMPAIGN  
 FOR THE COMING SEASONS WITH  
 A STOCK OF FAHYS RELIABLE  
 GOLD FILLED CASES

THE RALEIGH  
 THE CAMBRIDGE  
 THE OLYMPIA

Contain all the requisite features  
 of perfect gold filled watch cases

*Fahys*

*Trade Mark*

CATALOGUE ON APPLICATION

JOSEPH FAHYS & CO.

ESTABLISHED 1857.

FAHYS BUILDING

NEW YORK.



F 596

THE CAMBRIDGE



F 525

THE OLYMPIA



THE RALEIGH

# The Last Shall be First. 1900

All conditions indicate that the last year of the century will be the best and most prosperous one. The retail jeweler can assure this beyond peradventure if he will carry in stock a complete line of

## The Standard Simmons Chains.

They are the best chains of the century, the acme of the chain-maker's art, and the 1900 line is better than ever. The same can be said of our

**CYRANO CHAINS, LOCKETS, SEALS AND  
MARLOWE BRACELETS.**

...AT JOBBERS...

# R. F. SIMMONS & CO.

Factory and Main Office:

New York Salesroom:

9-13 MAIDEN LANE.

ATTLEBORO, MASS.

SALESMEN FOR 1900.

Western Representative, **LOUIS E. FAY.**

Eastern Representative, **GEORGE L. SWEET.**

New York Representative, **JOHN DRAKE.**

# "1835 R. WALLACE"

## "The Stuart"

WE HERE ILLUSTRATE  
OUR NEW PATTERN IN PLATED  
FLATWARE "THE STUART."

THIS PATTERN WAS ORIGINALLY IN-  
TENDED TO BE MADE ONLY IN A VERY  
FEW PIECES BUT ON ITS INTRODUCTION  
TO THE TRADE THE POPULAR FAVOR  
WITH WHICH IT WAS RECEIVED PROMPT-  
ED US TO MAKE THE PATTERN  
COMPLETE:

WE HAVE NOW READY FOR  
DELIVERY OVER FIFTY (50)  
DIFFERENT ARTICLES WHICH  
INCLUDE NEARLY ALL OF THE  
FANCY PIECES AND HOLLOW  
HANDLED TABLE CUTLERY.

SEND FOR PAMPHLET NO. 12  
ILLUSTRATING THIS PATTERN.

**R. WALLACE & SONS  
MFG. CO.**

FACTORIES,  
**WALLINGFORD  
CONN.**

BRANCHES -  
226 FIFTH AVE. NEW YORK  
109 WABASH AVE. CHICAGO  
120 SUTTER ST. SAN FRANCISCO  
63 BASINGHALL ST. LONDON E.C.

SALAD  
SPOON.

SALAD  
FORK.

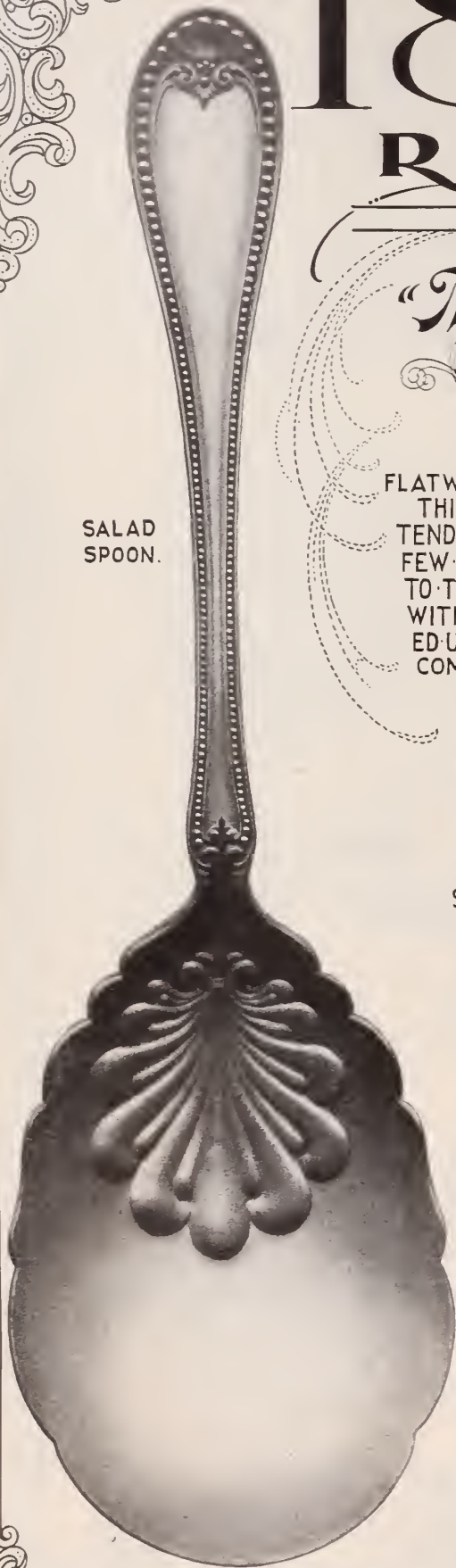

with open work at top of scroll handle; 220, salt spoon, leaf pattern handle, shell bowl; 221, mustard spoon, ornamental handle, masked knob; 222, salt spoon, cavalier at top of handle.

*Swedish Spoons. XVIIIth Century:*—270, spoon, twisted and chased handle, dated 1779; 272, spoon, woman and child at top of handle, twisted and chased stem, gilt; 273, spoon, hand holding two hearts at top, gilt, twisted stem; 274, spoon, mask at top, decorated and gilt; 275, spoon, mask at top, gilt, rich chased handle and rat-tail; 276, spoon, highly ornamented handle, ending in pierced wreath, inclosing bird.

*German and Dutch Spoons. XVIIIth and XVIIIth Centuries:*—277, spoon, figure of King William and Queen Mary, dated 1689; 278, spoon, chased handle with claw holding bowl, gilt, Augsburg, XVIIth century; 279, spoon, similar, gilt, XVIIth century; 280, spoon, figure of high priest at top of twisted and chased handle; 281, spoon, figure of woman at top of handle, plain bowl, gilt; 282, spoon, similar, enriched handle, engraved; 283, spoon, ornamented handle, pierced knob inclosing figure of "Charity;" 284, spoon, mask with wings at top of twisted handle.

(To be continued.)

**Jewelry Thought to Have Been Stolen by M. Hery Attached.**

WILLIAMSPORT, Pa., Jan. 3.—Johnson & Tomek, of Chicago, have issued an attachment against Chief Stryker for the jewelry taken from M. Hery when he was arrested on Dec. 12, charged with flim-flamming Huston Jackson, jeweler, out of a diamond ring valued at \$35. The jewelry in the possession of Chief Stryker consists of diamonds, eight rings and a stud, a gold watch and chain, a charm consisting of a \$10 gold piece, their aggregate value being over \$500. Accompanying this attachment is a bond for twice the value of the jewelry.

It is stated that Johnson & Tomek, with whom Hery was employed, have discovered that Hery owes them \$252.04. It is to recover this claim that the attachment is issued. Hery had, when arrested, \$301.40 in cash.

Sievers & Devers will put in a clock in the new court house in York, Pa.

**Latest Fashions in Paris.**

PARIS, France, Dec. 30.—Fancy has entered so deeply into all domains of the jewelers' art that even the chain bracelets, which formerly were the type of solid simplicity, have succumbed to the embellishing influence of that sorceress.

**NOVELTIES IN CHAIN BRACELETS.**

This embellishment concerns the shape of the chain links and the shades of the gold as well as decorations placed especially upon the chain surface. As regards the shape of the links, they are either plain or cylindrical, or are worked out upon the surface into small, embossed designs, or, lastly, their surface is divided, crystal-like, into small triangles or squares, placed together edgewise, which last described decoration is especially popular of late. In shades the latest models exhibit four gradations, copper red and a peculiar pale green being added to the dead and lustrous yellows. From these elements numerous other combinations are created, whose number is still increased owing to the fact that the chain links seldom occur in but one row, two, three or even more rows of links combining into a broad, flat bracelet. The connecting pieces of the links are frequently inlaid with small decorations of red or green gold tablets. To begin with the simplest models, should be mentioned a bracelet in which two rows of matt yellow, intertwining links form the breadth, running out into round scallops on the edges. Upon the middle connecting line of the two rows is a third raised row of links, which contrasts with the two lower ones by its lustrous copper red. The same model is also found in the reverse arrangement, the lower two rows of links being copper colored and burnished, while the upper one is dull yellow. The lower links of another bracelet are executed in burnished gold of a red copper color and cut like crystals in the above mentioned manner. On the surface are two more rows of smaller links, which are dead yellow and finely chased. In each arch of the scallops forming the edges appears a pale green ivy leaflet. A little narrower and flatter is a bracelet consisting only of two rows of circular, dull yellow links. The middle line only is decorated with alternating reddish and greenish leaflets.

A gorgeous effect is produced by four shades of gold in a richly decorated, broad bracelet. Four rows of round links are intertwined flat. The two in the center are dull yellow, but glitter only faintly through the top ornaments. The rows forming the outer edges consist alternately of glossy, cut links of red copper color and dull yellow ones with raised designs. The ornament on the center rows of links is composed of three rows of tiny, obliquely placed, square tablets, of which one is reddish and the other green in turn, there being a reversal of this order in every other row; a *carreaux* pattern is also visible in the three rows. Of the same style is another chain bracelet, but instead of the small squares, stars of the same description are substituted.

Deviating from the models so far described is a bracelet whose lower stratum consists of seven rows of very small and thin, interlaced links. This piece differs from the aforementioned styles in another particular, viz.: that while the others, owing to the heaviness of the solid links, are somewhat stiff and can only be bent just enough to surround the wrist; the last named style can be folded up several times, it being exceedingly pliable. The tiny chain links are of a lustrous yellow and are ornamented with green and red leaflets in such a manner that every two red ones and one green one form an angle together. These angular lines, which reoccur at regular distances, give the total effect of two outside rows of red leaves and one center row of green ones.

Besides these bracelets which are composed of round links there is another series, where the different links form flat, lustrous or dead plain or figured arabesques which converge only at the connections. Sometimes at the middle flourish of each arabesque a diamond or a colored gem is placed. Frequently there are connected, alternately, two arabesques or a rosette and an arabesque. Finally, I would mention another chain bracelet, with a simple but chased chain, longer than the arm requires. The two ends are tied up together into a knot and from the pendant chains two small balls in colored enamel are suspended. The closure of the chain, of course, is on the upper side of the arm.

FLANEUR.

OLIVINES OPALS SCIENTIFIC RUBIES	CATSEYES	SAPPHIRES	DIAMONDS	RUBIES	EMERALDS	PEARLS	PEARL NECKS	PEARL ROPES	Pearl Collarettes, mounted with Diamond Bars.
	<b>PEARLS, DRILLED AND UNDRILLED.</b>								
	<b>PEARL ROPES, NECKS and COLLARETTES.</b>								
	<b>We are buyers of American Pearls.</b>								
LONDON: 19-20 Holborn Viaduct. <b>JOSEPH FRANKEL'S SONS,</b> 68 Nassau Street, NEW YORK.									
TELEPHONE, 3899 CORTLANDT.									
<b>FANCY COLORED DIAMONDS and GEMS in PEARLS and PRECIOUS STONES.</b>									

**DIAMONDS.**  
**Wm. S. Hedges & Co.,**  
 IMPORTERS OF  
**Diamonds and Precious Stones.**  
**DIAMOND JEWELRY.**  
**170 Broadway, New York.**  
 28 Holborn Viaduct, London.

*Oppenheimer Bros. & Veith,*

*Importers and Cutters of*

*Diamonds*



*Dealers in*

*Watches,*

*Cor. Nassau and John Streets,*  
 (PRESCOTT BUILDING.)

*....New York....*

*Amsterdam,*  
*2 Tulp Street.*

*London,*  
*45 Holborn Viaduct.*

**MOUNT & WOODHULL,** FORMERLY WITH LATE FIRM OF  
 RANDEL, BAREMORE & BILLINGS,  
 . . . . IMPORTERS OF . . . .

**Diamonds, Other Precious Stones, Pearls, Etc.,**  
**Makers of fine DIAMOND JEWELRY,**

26 MAIDEN LANE (SOUTHWEST CORNER), NEW YORK.  
 NASSAU STREET

JOHN C. MOUNT.

ADDISON W. WOODHULL.

RUBIES.

SAPPHIRES.

**C. G. MALLIET & CO.,**

EMERALDS. 14 MAIDEN LANE, N. Y. DIAMONDS.

## The Bowden Rings

ARE COMPLETE IN VARIETY, CORRECT  
 IN QUALITY AND PERFECT IN FINISH.  
 WE MAKE EVERY VARIETY OF FINGER  
 RINGS

**J. B. BOWDEN & Co.,**

1 MAIDEN LANE,

NEW YORK.

### The World's Coral Supply.

Interesting Extracts on the Coral Output from  
 a British Consul's Report.

WASHINGTON, D. C., Jan. 5.—According to a recent report of the British consul at Leghorn, a considerable decline has occurred in the coral industry there. A number of boat owners have abandoned their former occupation of collecting the material and turned to the sponge fishing instead. Owing to this fact and the growing scarcity of coral at Sciacca, rates of the raw material have risen. The condition of the Indian market, it was stated in the report, remained unvaried, and exporters could not obtain a legitimate advance. The demand among the Nepalese on the Calcutta market was referred to as having been brisk and sales considerable, but at prices unremunerative to the producers. This position, it is stated, claims some attention, not only because the coral trade of India is a valuable one, but also because there are possibilities that India might become a producing country on a far larger scale than at present.

There are two classes of coral known to commerce, one being the reef forming variety which fringes the coast or forms reef encircled isles, such as the Maldives, Laccadives and Nicobars. On the mainland also there exist extensive beds of ancient coral reefs like those along the Malabar coast, Tinnevely, etc., while coral of still more ancient formation is found in Sind. The ornamental corals which luxuriate under lower temperatures are found in tropical seas, especially in the Persian Gulf and the Red Sea, at much greater depths than the reef forming, and are to some extent distributed thence into the congenial seas of temperate regions far beyond.

In dealers' shops in Europe, corals of diversified form, color and shape, such as the white coral, "brainstone," "organ-pipe," "seapens," "seashrubs," black coral, and last, but by far the most valuable, the red coral are found. Most of these genera are temperate, but the seashrub attains its greatest development in tropical seas.

In India, briefly, little is known of the ornamental corals contained in its waters. There are no coral fisheries, and no one can say with certainty whether or not this is due to the absence of corals or to commercial value. Nor is anything known apparently as to the likelihood of valuable corals succeeding if transplanted into Indian seas. No effort, it seems, has been made as yet to propagate species or improve those now existent. So much is known—it has been stated that in certain bazaars along the coasts of Amherst and Mergui, specimens of various kinds are to be met with. "Tree corals" are plentiful on the Tavoy Coast, some specimens of which are described as remarkably beautiful, presenting superb sea groves of variegated hues and forms. A handsome coral resembling a tuft of long moss also occurs; and black coral of which beads are made is brought from the Mergui Archipelago. Some conception of the magnitude of the trade in coral in India may be formed from the mere consideration of



how many races of people regularly wear necklaces of the article.

The finest red coral is obtained from the Mediterranean; the large pieces of a pale color are said to be often worth 20 times their weight in gold. It is the rejected pieces and inferior qualities that are exported to Asiatic countries, and India receives a very large share of this inferior red coral. In one of the reviews of the trade of India it was observed that the condition of the trade in coral constituted a very accurate gauge of the condition of the agricultural classes in the northwest Provinces and the sub-Himalayan tracts. The bulk of the imports, it was stated, is bought by these classes to be worn as necklaces, the coral beads—when a man is wealthy—alternating with beads of gold.

**Captious Customer Makes Off with Three of Jeweler Jost's Watches.**

JERSEY CITY, N. J., Dec. 31.—A man entered Richard A. Jost's jewelry store, 185 Ave. D, Bayonne, about 6.45 Friday evening and asked to be shown some gold watches. He said he wanted to buy one for about \$35. Mr. Jost laid out on the counter a hunting case, gold filled watch for his inspection. "Let me see something better," said the prospective purchaser. Mr. Jost handed out another hunting case watch. The stranger critically examined it and then said: "Something better, please." The jeweler handed out an open faced watch. "Haven't you something better?" asked the man.

Mr. Jost turned to seek something to please the captious customer, when the latter hastily grabbed the three watches on the counter and fled out the door and around the corner, leaving his hand bag behind. Mr. Jost ran to the door and shouted, but the man had disappeared and was not to be found. Mr. Jost described him to the police as a man about 28 years of age, about five feet seven inches in height, with no moustache, wearing a light overcoat and dark Fedora hat.

**Large Quantity of Pro-Boer Buttons Seized at the Canadian Border.**

OTTAWA, Ont., Jan. 5.—Some days ago a large number of buttons on which were inscribed the words "Victory to the Boers," both in French and in English, were seized by the Customs officials in Toronto and forwarded to the Department here. The Department has sent out a circular to all Customs Collectors instructing them to be careful of importations from a certain company, whose name is given in the circular but withheld from publication, operating in New Jersey. All importations of the character mentioned are declared to be seditious under the Customs act, and are therefore prohibited.

**A. L. Campbell & Co. Have Some Undesirable New Year's Callers.**

SPRINGFIELD, Mass., Jan. 4.—Burglars went through the jewelry store of A. L. Campbell & Co., 485 Main St., early Monday morning, and stole a tray of pins worth about \$75. The visitors were frightened away before having time to make a careful exploration of the stock.

**Pearls** \_\_\_\_\_

**Opals**

Importers and Cutters **GOODFRIEND BROS.,** Precious and Imitation Stones

9-13 Maiden Lane, N. Y. 174 Weybosset St., Providence, R. I. 10 Rue Cadet, Paris.

TELEPHONE, 662 CORTLANDT.

**SCHULZ & RUDOLPH,**

...Importers and Cutters of...

**DIAMONDS..** .....AND OTHER....  
**PRECIOUS STONES.**

SOLE AGENTS FOR THE CELEBRATED

**JULES JÜRGENSEN WATCHES AND**  
**COPENHAGEN, CHRONOMETERS.**

28 John and 65 Nassau St., New York.

**John F. Saunders,** Cutter and Importer of

**DIAMONDS** AND OTHER  
**PRECIOUS STONES.**

FINE PEARLS A SPECIALTY.

68 Nassau St., cor. John St., Sheldon Building,  
Room 16, NEW YORK.

1900. \_\_\_\_\_

**Everybody Happy!**

**THE RETAIL TRADE**

should hasten to replenish their stock of

**The "Bryant" Rings.**

than which nothing is more sure of sale.

DON'T WAIT FOR OUR TRAVELERS, BUT SEND AT ONCE TO

**M. B. BRYANT & CO.,**

10 MAIDEN LANE, NEW YORK.

## PEARLS.

## The Right Goods At the Right Time.

Fashion affects gems as it does dress.  
Certain gems are fashionable to-day;  
others to-morrow.

Our stock is always replete with the  
right goods at the right time.

Emeralds and Pearls at present.

## Alfred H. Smith & Co.,

182 Broadway, N. Y.

CHICAGO,  
103 State Street.

LONDON,  
21 Holborn Viaduct.

## DIAMONDS

And Other Precious Stones.



“The  
Pearl  
House.”

We have no salesmen;  
call or write.

## EISENMANN BROS.,

PARIS, 3 Rue St. Georges.

21 & 23 MAIDEN LANE, NEW YORK.

## MATHEWS & PRIOR,

DESIGNERS AND MAKERS OF

## Sterling Silverware

TO THE LEGITIMATE

## JEWELRY TRADE ONLY,



245-247 West 28th Street,  
New York City.

## Precious Stones: London Market.

HATTON GARDEN, London, Eng.

Dec. 23, 1899.

Last week was described as the blackest England has experienced for many years. All interest in diamonds centered at the Stock Exchange, where each reverse to British arms in South Africa was instantly effective upon stocks. The failure of Lord Methuen to force the Boer position at Magersfontein was the first serious check as regards DeBeers, it being at once apparent that the relief of Kimberley, which was expected daily, was indefinitely postponed. Sir Redvers Buller's reverse completed the series of misfortunes. At the outbreak of war the quotation was about 25, a month later, on the strength of Lord Methuen's advance towards Kimberley, considerable rises took place, bringing the price up to 29½ on Dec. 1. On the 19th the full effect of the British reverses culminated in 22¾, a gross fall of 6½, or over 22 per cent in less than three weeks. Some recovery has taken place since the panic subsided, but quotations are again about 23. These facts are important as regards the Stock Exchange opinion of the prospects of the rough diamond market.

No further advance in rough is announced. Gloomy anticipations as to future trade are heard on every side. Great numbers of fashionable gatherings have been canceled and the nation is stated to be practically in mourning.

Advices from Antwerp and Amsterdam continue depressing. In the former city 13 cutting factories out of 57 had closed up to a fortnight ago. R. F.

## General Benjamin E. Cook Celebrates His 96th Birthday.

SPRINGFIELD, Mass., Jan. 3.—The oldest jeweler in Massachusetts and very likely in New England, General Benjamin E. Cook, celebrated his 96th birthday in his home in Northampton, Sunday. Besides being the oldest jeweler in the State, General Cook is a high degree Mason. In the jewelry business he has been engaged all his life. One of his sons, Frank A. Cook, was captain of the United States cruiser *Brooklyn* during the Spanish-American war, and another, B. E. Cook, Jr., has been Mayor of Northampton. Another son, George W. Cook, is in business in New York. The General is wonderfully vigorous and daily takes a lively interest in his business affairs, in which he is greatly assisted by his son, B. E. Cook, Jr.

Benjamin E. Cook was born in Hyde Park, Vt., and is descended from American fighting stock. His ancestors took prominent parts in the Indian and Revolutionary wars. His father was Captain Elias Cook, a Revolutionary patriot. The General, when barely of age, was made lieutenant of a militia company in Hudson, N. Y., and soon after, in 1829, when he had removed to Northampton, was made captain of the Northampton Artillery. He gained the title of General from having been a brigadier-general of the Massachusetts militia. He had this command from 1850 to 1856.

### Latest Information Regarding Mineral Prospecting in Canada.

TORONTO, Can., Jan. 6.—The Ontario Provincial Government has been prosecuting the work of mineral exploration in the southern and eastern districts with considerable activity lately, with the result of some important discoveries as to the character of the deposits of mineral wealth now waiting development. The report of the Bureau of Mines for 1899, just issued, contains much valuable information as to the corundum belt in the eastern part of the province, embracing an area of about 300 square miles, containing tracts of rock of the nepheline syenite formation. Tests made show a yield of corundum varying from 12 to over 15 per cent. Corundum occurs under many forms in India, there not only being large deposits of the common form, but the most highly prized specimens of its transparent red variety, the ruby, are obtained from the famous mines of Burma, and the blue variety, the sapphire, is the product of the Kashmir district. Some of the modes of the occurrence of corundum in India are similar to the rock formations in Ontario, hence the course of exploration in this province has excited the hope that gems of value may be discovered. So far this expectation has not been realized. On this point the report says: "In the Ontario region the corundum occurs as an original constituent of the igneous rocks, while in India most of the corundum, including the gem varieties, occurs in crystalline limestones and is a product of metamorphosis."

The report suggests that search in the crystalline limestones might be rewarded with better success: not that corundum of any quality has yet been found in the limestones, but because their relations to the gneiss are not dissimilar to those which obtain in Burma. Prof. Willet G. Miller on this subject says: "It is quite possible that corundum may yet be found in considerable quantity in crystalline limestone in Ontario, as in India and Burma. In India the mineral occurs under various conditions in metamorphic (limestones, etc.) and igneous rocks. Of course, there need be no connection between the occurrence of the mineral in these two classes of rocks. If corundum occurs in our crystalline limestones, it is of a different origin from that occurring in the igneous rocks."

Later developments seem to justify this opinion, as specimens of crystals very closely approaching sapphire gems have been found in Hastings county, occurring in a narrow outcrop of syenite lying between two bands of crystalline limestone. Some are in nests and some in isolated crystals.

### Proceedings of the Jewelers' League.

The regular monthly meeting of the executive committee of the Jewelers' League was held at the League office on Jan. 5. There were present Vice-Presidents Greason and Bardel, Chairman Van Deventer, Messrs. Karsch, Lissauer, Street and L. Stevens, Jr., secretary.

The report of the treasurer was presented and approved. Two requests for change of beneficiary were received and upon motion granted and the following ap-

plicant was admitted to membership: M. Kohn, New York, recommended by F. E. Rogers.

The following applicants were admitted to membership at a special meeting held Dec. 28, 1899: Wm. F. Hoffmann, New York, recommended by A. J. Cadmus and F. E. Knight; F. W. Wexler, New York, recommended by L. Wormser and J. King. The next meeting will be held Feb. 9.

A. T. Horine has opened a jewelry shop in Rossville, Tenn.

Mrs. Emily C. Wynn, wife of Joseph R. Wynn, a retired jeweler of Baltimore, Md., who was formerly located at Baltimore St. and McClellan Alley, died Dec. 28, aged 66 years.

### Interesting Meeting of the American Horological Society.

CHICAGO, Ill., Jan. 6.—The American Horological Society held one of the best attended meetings for a year, on Jan. 4, at the rooms of the Chicago Jewelers' Association, Columbus building, when important matters affecting the future of the society were discussed. It was decided to secure a permanent home for the society and a committee were appointed with full power to make the selection. A second committee were empowered to buy library fixtures, the library room to have all facilities for both city and out-of-town members. W. F. Thompson was appointed librarian. This securing of a home for the society was the incentive of the annual Fall exhibition given by the

# WE

desire to thank our friends in the trade for the courtesies received from them during the year just closed, and to assure them that in the future as in the past our constant endeavor will be to serve them intelligently and faithfully, treating their interests as our own. We wish them all a prosperous New Year and will do all in our power to help them realize the wish.

## HAYDEN W. WHEELER & Co.,

TWO MAIDEN LANE, N. Y.

50 HOLBORN VIADUCT, LONDON.

society, and the fulfillment of the early desires will give greater strength to the society in the future. The finance committee of the Fall exhibit made their final report at the meeting Thursday. The total subscriptions were \$1,135 and the total expenditures \$999.06, leaving a balance in the treasury of \$135.94. After May 1 an initiation fee of \$1 will be charged in addition to the annual membership dues of \$1.

The following new members were added to the society at its last meeting: L. H. Potts, Mt Jackson, Pa.; J. A. Collins, Amberg, Wis.; Charles Peck, Ottumwa, Ia.; W. G. Keeler, Benedict, Neb.; W. A. Persey, Valley City, N. D.; Julius Dodt, Belleville, Tex.; Lucas Hurzwurm, Shawano, Wis.; J. B. Early, Humphreys, Mo.; Saml R. Weaver, Summerville, Ga.; G. A. Harris, Chicago.

Adjournment was taken after the most satisfactory meeting, judged from results, that the society has had.

#### Latest Swedish Tariff Regulations Regarding Watches.

WASHINGTON, D. C., Jan. 4.—According to a regulation of the Swedish General Customs Management, watches with a case other than gold, which have so far paid a duty of 50 oere (13.4c.) per piece will in future pay 1 krone (26.8c.) apiece—the same as watches with gold cases—if the cases are in any way coated with gold.

E. Huhn, optician, Greenville, O., has been advertising that he will retire soon from business.

#### Importations at the Port of New York.

Weeks Ended Jan. 6, 1899, and Jan. 5, 1900.

	1899.	1900.
China, Glass and Earthen Ware:		
China .....	\$35,812	\$52,446
Earthen ware .....	15,701	12,256
Glass ware .....	18,795	17,207
Optical glass .....		79
Instruments:		
Musical .....	7,434	20,731
Optical .....	1,608	4,074
Philosophical .....	1,364	850
Jewelry, etc.:		
Jewelry .....	3,073	10,344
Precious stones .....	215,278	71,620
Watches .....	6,006	19,805
Metals, etc.:		
Bronzes .....	718	1,139
Cutlery .....	3,087	3,925
Dutch metal .....		1,923
Platina .....	17,815	23,066
Silver ware .....	436	
Miscellaneous:		
Alabaster ornaments .....	272	
Beads .....	3,041	789
Clocks .....	2,977	2,523
Fans .....	7,069	4,326
Fancy goods .....	4,003	6,510
Ivory .....	2	3,928
Ivory, manufactures of .....	629	
Marble, manufactures of .....	1,507	13,972
Statuary .....	6,841	1,111

#### Traveling Optician Kills a Man.

MOBILE, Ala., Dec. 31.—Monday night at Sunnysouth, 100 miles north of Mobile on the Southern railroad, Dr. W. H. Williams was shot by Charles M. Gallagher, a traveling optician. Williams died next day. Gallagher surrendered, saying he was shooting at another man, and Williams was his friend.

#### H. Koester & Co.'s Stock Seized Under Mortgage to Bank.

DETROIT, Mich., Jan. 5.—The Home Savings bank, of this city, to-day took possession of the wholesale jewelry store of H. Koester & Co., 106 Woodward Ave., under a chattel mortgage for \$11,000. This action was due to the demands made upon Mr. Koester by eastern creditors, to whom he owes about \$8,000.

In 1893, at the beginning of the commercial depression, Mr. Koester gave the bank a mortgage for \$31,000 and since then has steadily cut this sum down until at present he owes the bank only about \$11,000, including the mortgage and notes. He says that had it not been for the demands of eastern creditors, which he characterizes as unreasonable, he would have ultimately been able to pull through all right. His holiday business this year was above the average, in fact it was the best since 1892, and the day before he received a summons from the bank he sent drafts east in payment of merchandise. The bank, however, insisted on protecting its interests, understanding that eastern creditors proposed to enforce the payment of claims, by seizing the stock.

Mr. Koester has been in business in this city for 30 years. Fred Clotte and George L. Lowe, formerly traveling representative of H. Koester & Co., have been appointed appraisers.

W. W. Boyer, South Bethlehem, Pa., will occupy a new store room at 428 Wyandotte St.

# DOLLARS ARE WHAT COUNT.

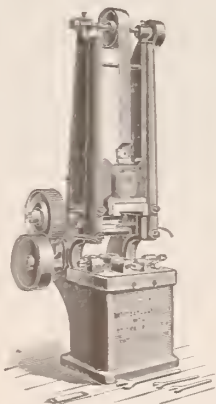

No. 5 Automatic Drop Press.  
Made in 12 Sizes.

OUR DROP PRESSES embossed more gold and silver last season than all the drop presses of other makes combined; they are money makers. Perhaps they will enable you to do work that you've never yet been able to handle to your satisfaction or profit in a satisfactory and profitable manner.

SEND FOR DROP PRESS BOOK.

WE ALSO MANUFACTURE ALL KINDS OF

**JEWELERS' AND  
SILVERSMITHS'  
MACHINERY.**

WESTERN OFFICE:  
Mercantile Bank Building,  
Cleveland, Ohio.

## MOSSBERG & GRANVILLE MFG. CO.,

NEW YORK, 126 Liberty St.

PROVIDENCE, R. I.

Philadelphia Bourse.

# **A RUMOR DENIED.**

The following cable, dated Paris, January 5, 1900, speaks for itself:

*HARRIS & HARRINGTON,  
34 Vesey St., New York.*

*Insert in trade publications that GLADSTON & BARRY, wholesale optical merchants, Paris, are authorized by LEMAIRE, of Paris, the well-known opera glass maker of this name, to denounce the announcement of the formation of a Le Maire Optical Co., with which he is to be connected, as false.*

*(Signed), GLADSTON & BARRY.*

The above refers to a report published in various papers that Lemaire, of Paris, was about to establish two factories in the United States.

**Manufacturers' Board of Trade.**

**Full Text of the Annual Report of Secretary Morton of the Manufacturing Jewelers' Board of Trade.**

PROVIDENCE, R. I., Jan. 6.—The report of the secretary of the Manufacturing Jewelers' Board of Trade, Marcus W. Morton, has been issued and shows that the Board is in a prosperous condition. The report follows:

PROVIDENCE, R. I., Dec. 30, 1899. To the Officers and Members of the Manufacturing Jewelers' Board of Trade:

GENTLEMEN:—I have the honor to submit herewith the Sixteenth Annual Report of the transactions of the Board for the year ending with even date.

As will appear, members were interested in the following named persons, firms and corporations:

- FAILURES FOR 1899.**
- Bicknell & Wood Co., Providence, 1 creditor, \$82,000.
  - Johnson & Gillespie, Boston, 11 creditors, \$2,341.90.
  - Morrill Bros. Co., Boston, 8 creditors, \$976.94.
  - M. C. Toppan, Boston, 1 creditor, \$90.54.
  - E. M. Dickinson, North Adams, 2 creditors, \$150.19.
  - Jacob Belgard, New York City, 12 creditors, \$1,525.51.
  - William E. Cohn, New York City, 10 creditors, \$1,504.13.
  - M. Goldsmith, New York City, 5 creditors, \$1,567.40.
  - M. C. Spencer & Co., New York City, 3 creditors, \$213.55.
  - Hills & Whitbeck, New York City, 5 creditors, \$625.39.
  - Higgins Bros., Oswego, 1 creditor, \$264.27.
  - Mockridge Sterling Co., Newark, 8 creditors, \$3,114.25.
  - A. R. Justice & Co., Philadelphia, 1 creditor, \$1,533.93.
  - L. A. Scherr & Co., Philadelphia, 15 creditors, \$7,112.07.
  - George W. Biggs & Co., Pittsburg, 4 creditors, \$275.64.
  - Moore & Leding, Washington, D. C., 3 creditors, \$397.51.
  - V. D. Tusten, Houston, Tex., 3 creditors, \$646.02.

- John Hellerich, Detroit, Mich., 1 creditor, \$138.32.
- Frank Bros., Chicago, 17 creditors, \$2,710.34.
- A. E. Paegel, Minneapolis, 3 creditors, \$375.00.
- E. Lytle, St. Paul, 2 creditors, \$231.92.
- Herman Idzal, Des Moines, 7 creditors, \$721.92.
- A. Rosenfield, Kansas City, 1 creditor, \$166.21.
- E. L. Nathan, Denver, 1 creditor, \$175.27.
- Roth Importing Co., Denver, 3 creditors, \$538.95.
- Alex. I. Wyatt, Salt Lake City, 1 creditor, \$397.45.
- Levi & Michaels, Halifax, N. S., 14 creditors, \$2,556.31.

**SETTLEMENTS AND DIVIDENDS.**

- Johnson & Gillespie, Boston, 30 per cent cash.
- William E. Cohn, New York City, 25 per cent cash.
- M. Goldsmith, New York City, 20 per cent cash.
- M. C. Spencer & Co., New York City, 50 per cent cash.
- Higgins Bros., Oswego, N. Y., 12½ per cent first dividend.
- Mockridge Sterling Co., Newark, 25 per cent cash.
- A. R. Justice & Co., Philadelphia, 50 per cent cash.
- L. A. Scherr & Co., Philadelphia, 30 per cent first dividend.
- Moore & Leding, Washington, D. C., 50 per cent cash.
- John Hellerich, Detroit, 25 per cent cash.
- Frank Bros., Chicago, 15 per cent first dividend.
- A. E. Paegel, Minneapolis, 17½ per cent.
- E. Lytle, St. Paul, .0558 per cent cash.
- Herman Idzal, Des Moines, 3½ per cent first and final dividend.
- Roth Importing Co., Denver, 25 per cent cash.
- Alex. I. Wyatt, Salt Lake City, .3241 per cent cash.

**PREVIOUSLY REPORTED CASES.**

- B. Eckstein & Co., New York City, 4 17-100 per cent. Assignee's dividend.
- Roth & Glick, Cleveland, 10 per cent.
- Summer Bros., Cleveland, 4 per cent final dividend.
- Anderton, Eberhardt Co., Dayton, 36 per cent cash.
- F. G. Smith, Sons & Co., Detroit, 7 9-10 per cent final dividend.
- W. & E. Schmidt, Milwaukee, 50 per cent cash.
- Burnett, Ansley Jewelry Co., St. Joseph, 1 per cent final dividend.
- Isaac Emmer & Co., St. Louis, 10 per cent first and final dividend.
- S. Beck, Dallas, 5 per cent final dividend.
- Of the remaining cases:
- The Bicknell & Wood Co. assigned to C. Frank Parkhurst. Assets, stated at about \$20,000, with liabilities of \$15,000.

Morrill Bros. Co. assigned it is said for the purpose of winding up the business of the company and the formation of a new firm. An offer in composition was made of 30 per cent cash or 40 per cent in notes of Morrill, Clough & Thayer, payable one-half in 12 months and one-half in 18 months. This offer was made Nov. 2, 1899, but has not as yet been carried into effect.

M. C. Toppan assigned to Arthur F. Teel. Assets, \$3,240. Liabilities about \$10,000.

E. M. Dickinson assigned to Charles L. Frink, with assets stated at \$12,800. Liabilities, \$15,862.42. Early in the year he was adjudged a bankrupt, and while many rumors were in circulation, his examination before the referee in bankruptcy failed to confirm or substantiate any of them; his statement that he had no property whatsoever than what had been delivered over to the trustee was not impeached by any evidence submitted.

Jacob Belgard was closed on executions amounting to \$243. The stock was sold by the sheriff for \$360. Since the closing of his place of business, his whereabouts are not known, he having left the city.

Hills & Whitbeck confessed judgment in favor of Robbins & Appleton, and immediately following made an assignment to Irving Smith. The assets are stated at \$5,500, with liabilities of \$15,000. It is expected that the assignee will not be able to close the estate before March 1, 1900, the delay arising from obligations which do not finally mature until nearly that date.

George W. Biggs & Co. filed a petition in bankruptcy with liabilities of \$65,583.91. Assets, \$72,315.16, and at the first meeting of creditors J. M. Stoner, Jr., was elected trustee. By an order of Court he sold the stock for \$6,800, the appraised value being \$8,000. Five bids were received, the highest, by two parties, being \$5,100, resulting finally in the closing bid of \$6,800 being accepted.

A. Rosenfield was adjudged a bankrupt under the Bankrupt Act, with not sufficient assets above exemption available for creditors.

E. L. Nathan, in connection with J. S. Neall, were adjudged bankrupts with no estate, and later were granted a full discharge from all debts provable against their estate under the Bankrupt Act.

Levi & Michaels were closed on executions amounting to \$16,942. An inventory of the stock and fixtures was taken, the value being \$40,622.09 as against nominal value by the firm of \$71,000. Their direct liabilities were about \$44,000 with indirect liabilities of about \$45,000. Arrangements were made to dispose of the stock and fixtures by bids for same, but not proving satisfactory they were sold by the Sheriff, the proceeds being absorbed by the judgments entered.

In the matter of L. A. Scherr & Co., a final dividend, small in amount, is expected to be paid by the trustee early in the coming year.

The Frank Bros. Estate is in litigation, and prospects for any additional dividend therefrom are not encouraging.

COLLECTIONS.		
Claims received	.....	242
“ collected	.....	159
“ withdrawn	.....	22
“ uncollectible (returned)	.....	22
“ pending	.....	39
159 collected		..... \$14,446 00
22 withdrawn		..... 2,588 11
22 uncollectible		..... 1,331 24
39 pending		..... 5,062 59

In addition to the above amount collected, \$1,300.15 has been received on previous pending claims.

Of the total amount collected \$8,905.88 was without expense to members.

**REPORTS.**

There were 510 regular numbered and 747 incidental reports issued, and 2,658 inquiries answered during the year.

**MEMBERSHIP.**

Number of members last report	.....	84
Admitted	.....	4
From which deduct, resigned	.....	5
Out of business	.....	4
Present membership	.....	79

A review of the year now closing must bring to mind the fact that prosperity has once again smiled upon the industry represented by this and allied organizations, and after a succession of years of depression, all have enjoyed, to a greater or less degree, a successful period during the past 12 months.

While this has been, and is, very gratifying, it should also be impressed upon the minds of all that even prosperity may prove to be dangerous in its enjoyment, if thereby we are lax in our scrutiny and vigilance in the disposition of our goods.

There has appeared in the market, seemingly more than ever before, a class of prospective buyers almost wholly unknown, and either in person or by correspondence endeavored to establish themselves as jobbers or dealers in our lines. Whether actuated by purely selfish or monetary considerations to further their own ends, or imbued with the opportunity the general prosperity of the country affords, to obtain a commercial standing, may not

**TO WATCH DEALERS:**

IT should interest you to know that all through the holiday rush our customers were protected in sales and profits ON WATCHES.

By early preparation we were enabled to respond immediately to their calls. Our business was phenomenal, yet

**NO ONE WAS SLIGHTED.**

You can readily appreciate the value of such service.

WE ARE THE LARGEST DISTRIBUTORS OF

**Dueber-Hampden Watches**

IN AMERICA.

“Send us your orders; we'll serve you well.”



*John W. Pierwood & Co.*  
Watches. Chains. Diamonds. Jewelry.

No. 3 MAIDEN LANE, NEW YORK.

# THE DUEBER HERALD

THE ADVOCATE OF HONEST BUSINESS METHODS.  
 ✻ DEVOTED TO THE RETAIL JEWELRY TRADE. ✻

Vol. I.

CANTON, OHIO, JANUARY, 1900.

No. 12.

## THE BEGINNING.

What is worth doing, is worth doing well.

\* \* \*

To do well, if you do not begin well, is difficult; if, indeed, not impossible

\* \* \*

You cannot begin the New Year better—in a business way, that is—than by determining to investigate the claims and assertions made by the management of the Dueber-Hampden Works.

\* \* \*

Do it; and do it well.



## CAUSE AND EFFECT.

The management of the Dueber-Hampden Works have for years, persistently and assiduously, opposed every measure, policy, coalition, "new invention" or device, etc., that tended to work harm to the interests of the watch dealers and watch purchasers of the country,

AND

every measure, policy, coalition, "new invention" or device, etc., so opposed, has proved to be, as the management of the Dueber-Hampden Works predicted, a **FAILURE!**

### "THE BEST."

Charleston, N. C.

I am carrying a 17-jewel Hampden watch. It is the best watch in the country.

C. S. MORRISON, Conductor,  
 Richmond & Danville Railroad.

## THE MATTER OF DESCRIPTION.

You may describe a horse as being decked all over with gilt tassels, but if it cannot **trot**, the bombastic description of its tassels won't make it win a race.

You may describe a watch as being fitted with as many frills as you please; you may make the description as bombastic as you please; but neither frills nor bombast will make the watch keep time.

There is nobody in the offices of the Dueber-Hampden Works gifted with sufficient brilliancy to create for the Dueber-Hampden Watches such highfalutin, mystifying descriptions as are employed for other watches we know of.

The Dueber-Hampden product is: Closely running watches—the closest-running watches ever produced; they're stylish, they're modern, they're "The Best." And that's all the description that goes with them.

Most important: The description fits the goods!



## HOW DUEBER GOODS ARE SOLD.

The Dueber-Hampden Works sell their entire product only through the wholesale and retail watch dealers of the United States, and they do not solicit nor accept orders from Department Stores, Farmers, Supply Houses, etc.

## "FOR EXAMPLE."

"We defy competition."

\* \* \*

A strong assertion to make, isn't it? But who can find fault with it if it's substantiated?

\* \* \*

The Dueber-Hampden Works assert it. Their product substantiates it.

\* \* \*

Their three new 12-size watches and "The Four Hundred," for ladies, for example.



## THE REASON.

The three new 12-size movements of the Hampden Watch Works, the "Dueber Grand," 17 jewels; the "Dueber Watch Co.," 17 jewels, and the "John Hancock," 21 jewels, are sold **only** in the 14 and 18 karat solid-gold and 14-karat gold-filled watch cases of the Dueber Watch Case Manufacturing Co., in order to protect the retailer, and prevent the sale of these movements in, for instance, so-called "40-dwt. solid-gold cases," containing 20 dwts. of lead.

### "THE BEST" AGAIN.

Central City, Ky.

I am wearing a 17-jewel Hampden watch to run an engine on the N. N. & N. V. R. R. It is the best I ever saw.

HENRY FRISS.

be readily determined; but all efforts should be made to so decide that are placed within our reach.

Every safeguard should be employed to aid in all credit transactions, and every improvement in the system be adopted and carried into practice, to the end that the smallest percentage of losses accrue. Not that there are no losses, for there are times that are unavoidable; but that they may be brought to the minimum.

Much has been written and printed during the year concerning the National Bankruptcy Law, both for and against it; but thus far it seems to be conceded that its effect in general has been wholesome and for the best.

In some features it appears desirable that changes should be introduced, and in some instances several State Bar Associations, together with the National Credit Men's Association, have discussed forms of amendments that would prove beneficial thereto.

The consensus of opinion, however, seems to favor a further trial of the Act, and a more intimate knowledge of its operations, before venturing upon the introduction of amendments.

One noticeable fact in the report of failures during the year is the amount involved. Never before in the history of the organization has it reached so small a figure: \$28,000. Not only will this apply to our own industry, but it is believed when the report of the commercial interests of the country is completed, it will disclose the same fact.

It is fitting, in closing, to allude to the loss of another of our members by death, Elton I. Franklin, of the firm of E. I. Franklin & Co., North Attleboro, Mass.

The firm was identified with our Association from its early history, and Mr. Franklin was chosen a director and served in that capacity for a number of years with promptness and fidelity.

A man courteous and gentlemanly in his deportment, genial and fraternal in intercourse, one who claimed and held the confidence and esteem of all who knew him.

Respectfully submitted,

MARCUS W. MORTON,  
Secretary.

This report was presented and accepted

at the meeting of the Board of Directors, of which an account was given in last week's CIRCULAR.

#### Unique Clock Planned for the Court House at Detroit.

DETROIT, Mich., Jan. 5.—This city is just completing one of the finest court houses in the United States, the cost of which has been about \$2,000,000. The county building committee are now considering the advisability of installing a tower clock suitable for such a structure. There is a noted clockmaker in this city, Felix Meyer, who is also an expert stone cutter. He is stone inspector on the county building. The committee believe he could construct a unique timepiece. Meyer built the Presidential clock that was exhibited in the cities of the northern and eastern States 20 years ago. It was afterwards sold to a New York physician. This clock is 18 feet in height. It is surmounted by a figure representing Liberty, below which is a figure of George Washington holding in one hand the Declaration of Independence. At such intervals as the operator pleases a lever can be pulled which starts machinery in motion by which the Father of His Country raises the document as the Presidents pass by, each saluting and bowing. At every quarter hour a baby appears; at the half hour a young man comes along; at the three-quarters an old man takes his place, and at the hour, the end of the three epochs of life, Death takes the stage. As Detroit is a great convention city, it is suggested that the idea if carried out would be an additional attraction.

#### The French Reciprocity Treaty.

##### Eastern Manufacturers Active Against the Passage of Those Parts that Affect Their Interests.

ATTLEBORO, Mass., Jan. 5.—The jewelers of the Attleboros do not mean to let procrastination lose them their fight against the French reciprocity treaty, in so far as it directly affects them, in its dangerous reduction of the import duties on French jewelry and kindred manufactures. The following letter was framed Thursday by Frank W. Weaver, secretary of the Company C Tariff Committee, and copies were sent to Hon. Henry Cabot Lodge and Hon. William C. Lovering, of Massachusetts, and Hon. Nelson W. Aldrich and Hon. Melville Bull, of Rhode Island:

ATTLEBORO, Mass., Jan. 4, 1900.

DEAR SIR:—The Jewelry Tariff Committee of the Attleboros, Mass., and Providence, R. I., met last night at the Company C Association rooms in Attleboro and after discussing the Reciprocity Treaty between France and the United States signed last Summer, unanimously voted that our secretary be instructed to address a letter to yourself and your associates asking that you do all in your power to prevent the ratification of the above mentioned treaty so far as it relates to lowering the present import duties on jewelry, for the purpose of protecting the jewelry industry of New England.

The jewelers of New England, after years of depression, are entering on a season of prosperity made possible by the Dingley Tariff Law, and for this reason they are united in their opposition to the proposed treaty as being detrimental to their interests.

The Jewelry Tariff Committee having the matter in charge is the same body which was created when the new Dingley Tariff Law was formed, and the hearing on jewelry given to this committee by the Honorable Committee on Ways and Means, the records of which are on file with the

# "OMEGA" WATCHES.

NONE BETTER MADE. OVER 1,000,000 IN USE.

GOOD SELLERS EVERY DAY IN THE YEAR.

Place your orders early in the year for these watches and avoid later on the embarrassment of delay that you experienced last season.

We will accept orders and deliver WHEN you wish them.

These watches are sold only to the legitimate trade.

No prices advertised in any journal.

Made in 00 size.

" " 0 size.

" " 12 size.

" " 16 size.



Pendant Set. 12, 14 and 16 Size.  
Made in Gun Metal, Silver, Gold-Filled  
and Solid Gold Cases.

Send for Price-List.

Edmund E. Robert, 3 Maiden Lane, N. Y.;

Cross & Beguelin, 17 Maiden Lane, N. Y.,

SOLE SELLING AGENTS.



Clerk of the Ways and Means Committee, is evidence that the present duties are not more than adequate to protect either our labor or our products.

Therefore, in behalf of the jewelers of New England, we appeal to you and your associates to maintain the present tariff on jewelry as necessary to the future welfare of the people engaged in this industry. We also request you to keep us posted as to what is going on in connection with this tariff move.

Yours respectfully,  
 SIDNEY O. BIGNEY,  
 HENRY G. THRESHER,  
 WILLIAM R. DUTEMPLE,  
 EVERETT S. HORTON,  
 HARRY P. KENT,  
 ALBERT A. BUSHEE,  
 FRANK W. WEAVER, Sec'y.

Such faith in the abilities of the four above-named Congressmen is felt by the jewelers that they have left the whole task of opposing the treaty to them, but, if necessary, members of the committee stand ready to go on to Washington and lend their influence and display facts and figures to explain their position. All in the Attleboros realize the gravity of the situation and it is a constant theme of conversation.

PROVIDENCE MANUFACTURERS IN SYMPATHY.

PROVIDENCE, R. I., Jan. 6.—Local jewelry manufacturers are greatly interested in the strong fight which the jewelers of the Attleboros are making in opposition to that part of the proposed reciprocity treaty with France as affects directly their interests. A number of those who have been approached have expressed themselves as fully in sympathy with the stand that the manufacturers in the Attleboros have taken.

RECIPROCITY TREATIES HELD UP.

WASHINGTON, Jan. 8.—The reciprocity treaties which President McKinley has submitted to the Senate will be held up for the present. Strong opposition has developed to several features of the French treaty and the Argentine treaty.

Jewelers' Gold Bars Withdrawn and Exchanged.

Week Ended Jan. 6, 1900.

The U. S. Assay Office report:  
 Gold bars exchanged for gold coin..... \$118,824.86  
 Gold bars paid depositors..... 63,065.76

Total .....	\$181,890.62
Of this the gold bars exchanged for gold coin are reported by the Sub-Treasury as follows:	
Jan. 2 .....	\$10,152
" 3 .....	30,431
" 4 .....	31,793
" 5 .....	5,094
" 6 .....	20,608
Total .....	\$98,078

HEADQUARTERS

For....  
 Everything

Used by  
 Jewelers.



SEND  
 FOR  
 PRICE-  
 LIST.

THIS  
 WILL BE  
 A  
 GOOD  
 WATCH  
 YEAR.

Cross & Beguelin, 17 Maiden Lane, N.Y.

DESIGNS, QUALITY, PRICES,  
 Small Profits and Large Sales  
 combined have created the  
 great demand for the . . .  
 10k. and 14k. Gold Jewelry  
 MANUFACTURED BY  
**HANCOCK, BECKER & CO.,**  
 Providence, R. I.  
 SOLD THROUGH JOBBERS ONLY.

THIS IS THE SEASON  
 TO RENOVATE YOUR

Catalogue

DROP US A POSTAL  
 AND WE WILL BE  
 PLEASED TO FURNISH  
 ESTIMATES FOR  
 YOUR WORK.

MERIDEN GRAVURE CO.,  
 MERIDEN, CONN.

S. STERNAU & CO.,

204 CHURCH STREET, NEW YORK.

Manufacturers of METAL WARES

In Brass, Copper and Silver.

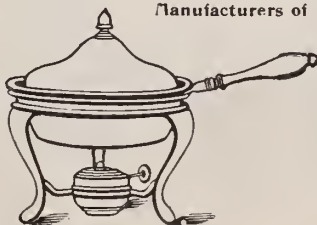

CHAFING DISHES,  
 KETTLES, TRAYS,

Crumb Trays and Scrapers, Bread  
 Baskets, Etc.

CATALOGUE ON APPLICATION.



### John L. Bell Assigns with Liabilities More than Double His Assets.

KNOXVILLE, Tenn., Jan. 4.—Jno. L. Bell, 129 Gay St., made an assignment late Tuesday afternoon in favor of his creditors. A petition in bankruptcy was filed by him, through attorney Chas. Brown. Referee Joshua W. Caldwell declared him bankrupt, and appointed W. H. Kephart temporary receiver. The creditors will meet here on Jan. 15, when a trustee will be selected to close out the business.

The liabilities amount to \$8,167.91. With the exception of F. D. Griffith, of this city, none of the creditors is secured. The assets, consisting of store fixtures, stock of jewelry, house and lot on Clinch Ave. and other items, amount to \$4,400. The schedule of liabilities in full is as follows:

F. D. Griffith, Knoxville, \$300.00; M. S. Benedict Mfg. Co., East Syracuse, N. Y., \$57.61; E. & J. Swigart, Cincinnati, \$51.83; C. Rogers & Bros., Meriden, Conn., \$25.54; Kossuth Marx Jewelry Co., New York, \$494.05; Joseph Mehmert, Cincinnati, \$510.14; Albert Bros., Cincinnati, \$385.04; Dennison Mfg. Co., Chicago, \$27.80; I. Michelson, New York, \$275.00; L. Kaufman & Co., New York, \$396.48; J. M. & A. C. Johnston, Chicago, \$79.13; W. H. Terhune & Co., New York, \$29.95; Eagle Pencil Co., New York, \$60.25; St. Louis Clock & Silver Ware Co., St. Louis, \$120.45; Sproehle & Co., Chicago, \$84.50; Ketcham & McDougall, New York, \$19.00; New England Jewelry Co., Providence, \$47.00; New England Watch Co., Waterbury, Conn., \$125.00; David Marx, New York, \$1,255.44; Benj. Allen & Co., Chicago, \$46.50; Jennings Bros., Bridgeport, Conn., \$17.60; S. Valfer & Co., New York, \$39.95; Quaker City Watch Co., Philadelphia, \$205.50; Jas. W. Tufts, Boston, \$198.50; C. B. Barker Mfg. Co., New York, \$123.79; J. B. Owens Pottery Co., Zanesville, O., \$50.00; Otto Young & Co., Chicago, \$50.40; E. A. Cowan & Co., Boston, \$804.41; Rosenzweig Bros., New

York, \$1,933.09; W. S. Finley, Nashville, \$183.48; Henry Hahn & Co., Cincinnati, \$44.68; Knoxville Sentinel Co., \$44.50; Knoxville Journal and Tribune Co., \$15.00; Knoxville Independent, \$6.00; total, \$8,167.91.

### Officers of the Manufacturing Jewelers' Board of Trade.

PROVIDENCE, R. I., Jan. 8.—The board of directors of the Manufacturing Jewelers' Board of Trade have organized by the reelection of the following officers: President, Dutee Wilcox, of D. Wilcox & Co.; vice-presidents, William R. Dutemple, of W. R. Dutemple & Co., and E. S. Horton, of Horton, Angell Co.; secretary and treasurer, Marcus W. Morton; financial committee, Robert E. Budlong, of S. K. Merrill & Co.; Henry Fletcher, of Fletcher, Burrows & Co., and Hon. Henry G. Thresher, of Waite, Thresher Co.

### Assignment of J. B. Williamson, Jobber, Montreal.

MONTREAL, Can., Jan. 4.—J. B. Williamson, jeweler, Notre Dame St. and St. Catherine St., this city, has assigned upon the demand of W. H. Hutchings. The liabilities amount to about \$30,000. The principal creditors are Schwob Bros., \$1,500; Backes & Strauss, London, Eng., \$15,000; B. Van Gelder, Amsterdam, \$2,500; A. C. Mackay, Renfrew, \$5,000; J. S. Budden, Quebec, \$2,000, and the M. S. Brown Co., Montreal, \$2,100. A. W. Stevenson has been named provisional guardian.

W. J. Schmidt, Genesee, Idaho, is out of business.

### Stubborn Fire in the Jewelry Trade of Providence, R. I.

PROVIDENCE, R. I., Jan. 6.—A blaze in the jewelry manufactory of Abraham Jacobs, situated in the rear of 205 Willard Ave., South Providence, stubbornly resisted the attacks of the firemen at a late hour last night. Before the fire could be brought under control it had made a clean sweep of the interior of the building and had done several thousand dollars' worth of damage. The proprietor of the establishment was in New York at the time of the blaze, and when the fire was discovered, Louis Jacobs, son of the proprietor and who lives directly opposite the factory, was immediately notified. No blaze was then visible, but smoke was pouring out of the westerly end.

The fire appeared to originate in the neighborhood of the staircase on the ground floor in the west end and had then been drawn up through to the other floors and been swept along by the breeze the entire length of the building. The fire on the ground floor was subdued after some difficulty and after more than an hour's stubborn fighting the blaze on the second floor was under control. The building, however, was gutted with the exception of the east end of the ground floor. In the absence of the proprietor it was difficult to get a valuation of the stock, but his son thought that the stock was valued at about \$5,000. The insurance of \$1,200 on the building should go far toward rebuilding it, while there was an insurance of \$3,000 or \$4,000 on the stock it is said. Machinery in the unburned section was damaged.

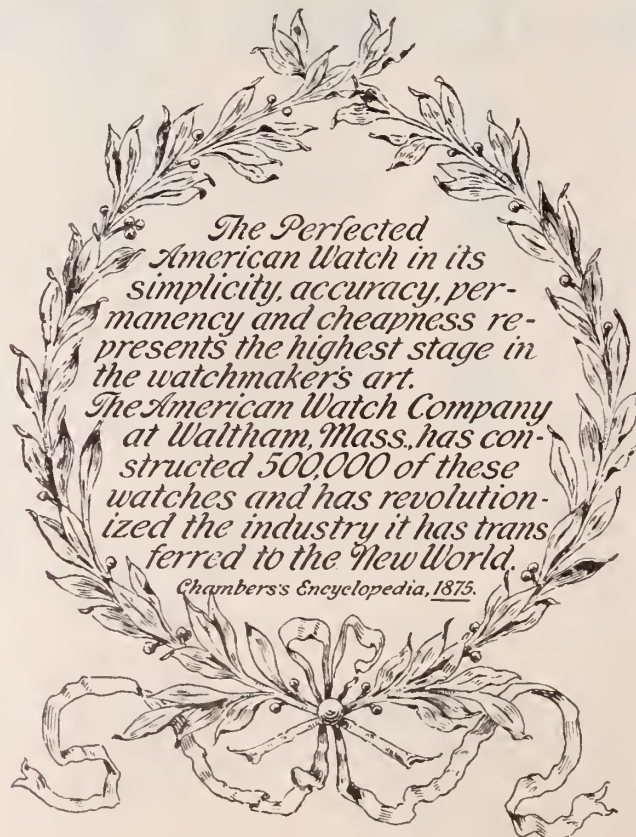

**Joseph C. Dueber's Brief but Valuable Career.**

CANTON, O., Jan. 3.—The funeral services of Joseph C. Dueber, whose death has already been reported in these columns, were held yesterday morning at 9 o'clock. The interment took place to-day at the family lot, St. Bernard's cemetery, Cincinnati. These employes of the Dueber-Hampden works, who had been fellow workers and friends, most of them, for 20 years, acted as pall bearers: Henry Detmering, Frank Schleininger, William Doll, Max Loebnitz, Lawrence Nelson, Joseph Brennan.

Joseph C. Dueber, who was 28 years of age, died at the residence of his parents, Mr. and Mrs. John C. Dueber, 848 N. Market St., from hemorrhage of the lungs, at 6 o'clock Sunday morning. He had been ill for five years, consumption resulting after an attack of typhoid fever in the Spring of 1894. For two years and more he had been confined to his home. During all his sickness his mother had scarcely been out of hearing of his call. He was the sixth child lost to Mr. and Mrs. Dueber, the others passing away in infancy in Cincinnati. Last Wednesday he was able to be about his room. He wrote a letter of acknowledgment to Mrs. William McKinley for Christmas gifts, she having sent slippers, flowers and other remembrances to the invalid and dear friend at her Canton neighbor's home. Shortly after this the fatal hemorrhage came. Albert M. Dueber was summoned from Buffalo. Father, mother, brother and sisters sorrowfully waited for the parting.

Young Dueber early developed great mechanical ability. When working in the Hampden watch works he made great advancement. He formed many friendships among hundreds of his associates. Numerous deeds of kindness were done by him and were known to his family. Others are known now. He helped people to buy homes. He sent clothes and money and other gifts to those whose wants chanced to come to his knowledge.

He was not out of his teens when he represented important interests of the great industries bearing his father's name, in California, and but a short time before he felt the first attack upon his young and promising life, he had made a most successful trip to Europe, beneficent and progressive in its results, and demonstrating well by its incidents his keen business faculties, his untiring energy, and superior wisdom in a commercial warfare then just beginning, and since which time a great American industry in this city is shipping to Switzerland its superior products. There was much opportunity, and there was excellent ability to care well for it, when Joseph C. Dueber was entering upon his early business career.

**Death of William M. Gilmore.**

KENTON, O., Jan. 5.—William M. Gilmore, a prominent jeweler of this city, died very suddenly last Saturday afternoon. He had been troubled with heart disease for some time and had been ill for a few days. He was sitting up Saturday and, while his wife was at his store, was attacked and died before any of his relatives could reach his side. He was just 50 years of age.

**Death of George H. Coggsill.**

NORTH ATTLEBORO, Mass., Jan. 8.—The body of the late George H. Coggsill, who died last week in New York, was brought to his old home here for burial. Mr. Coggsill was a native of North Attleboro, and his first business venture was as G. H. Coggsill & Co. He was subsequently a member of H. H. Curtis & Co. and later traveled for Geo. L. Vose Mfg. Co. He was still later with David E. Makepeace and other concerns, and his last post of responsibility was the charge of the New York office of J. M. Fisher & Co. He had been ill from last September but had remained at his work. He leaves a wife who shared with him a pretty home in Brooklyn. The deceased was 39 years of age.

The funeral of Mr. Coggsill took place Sunday afternoon at 1.30 o'clock from the residence of Frank H. Cummings, Attleboro. Mr. Cummings is a brother of Mrs. Coggsill. Rev. Thomas Tyrie, of the Methodist Church, officiated, and the flowers from his former associates in the trade were very numerous and beautiful. The bearers were Henry H. Curtis, of H. H. Curtis Co., North Attleboro, and Charles M. Robbins, William C. Tappan, of the D. F. Briggs Co.; J. Thomas Inman, of J. T. Inman & Co.; Charles O. Sweet, of Regnell, Bigney & Co., and William H. McCoombs. Interment was at Woodlawn cemetery, Attleboro. Mr. Coggsill's place as head of the New York office of J. M. Fisher & Co. has been taken by Walter T. Fisher.

*1852-1900.*

*Forty-eight years* of business life,

*An unblemished reputation*

for products equal to the best,

*One standard—*

Sterling, 925-1000 fine,

*Experienced representatives,*

*A specialty of Tableware,*

salable the whole year through, are facts worthy your consideration in placing your orders for 1900.

*J. B. & S. M. Knowles Co.*

*Silversmiths,*

*91 Sabin St., Providence, R.I.*



TRADE-MARK.  
Established 1852.  
Incorporated 1891.

## Exclusive Rights,

as agents, will be given to jewelers in their city or town for the sale of **Bell Gold-Filled Watch Cases.** The jeweler can thus avoid the competition of department and other stores and control the best gold-filled watch case on the market. Write for particulars if you want to increase your profits.



You can control your own designs or please your customer with any special design, monogram, portrait, &c, that he may desire when you

**Buy of the Maker.**

**THE BELL  
WATCH CASE CO.,**

**CINCINNATI, OHIO.**

**Novelties  
for Men**



TRADE-MARK.

In 14Kt. Gold, Sterling Silver and  
*Ornamented with Jewels.*

**Woods & Chatellier,**

860 Broadway, N. Y.

42-46 Hill St., Newark, N. J.

**DON'T FORGET THE JEWELERS' CIRCULAR PUBLISHING CO.'S BOOK LIST** when in want of any technical work in the Jewelry or Kindred Trades.

## Providence.

Leo Popper & Sons, importers of imitation and precious stones, have removed from 139 to 96 Mathewson St.

J. L. Crandall has sold out his line of hat pins to Rhodes Brothers, Attleboro, who will continue to manufacture the same articles.

Summer & Kotler have removed from 290 Eddy St. to 19 Calendar St. W. C. Fisher will occupy the shop which the firm have vacated.

John Hagan, with E. L. Spencer & Co., has the sympathy of a large circle of friends in his bereavement occasioned by the sudden death of his wife, Sarah A. Hagan, in the early part of the week.

The annual report of the Collector of Customs of the Port of Providence, which will soon be prepared, will show that the importations of jewelry and precious stones for the past year have been almost unprecedented.

W. H. Grimshaw, formerly with B. A. Ballou & Co., started on Sunday night on a western trip as representative of George W. Dover. Mr. Grimshaw will handle Mr. Dover's line of collar buttons alone and his trip may extend to the coast.

George W. Parks, of Parks Brothers & Rogers, and J. F. P. Lawton, secretary and assistant treasurer of the Gorham Mfg. Co., were nominated as members of the board of directors of the Providence Board of Trade at a meeting of the nominating committee held last Wednesday.

A number of local jewelers are interested in the failure of Sherwin & Clarke, wholesale jewelers, Boston. Others are interested in the failure of the Horace Partridge Co., same city. Although this firm dealt in sporting goods, nevertheless, about two years ago, they made purchases of jewelry in this city and local manufacturers are accordingly interested.

The buyers descended upon the city in good numbers last week. Among them were: W. H. Kirby, Pittsburgh Dry Goods Co.; S. P. Myers, Canadian Jewelry & Importing Co.; J. and B. C. Silver, Montreal; M. Kingsbacker, Sol Cerf and M. Bonn, Pittsburgh; S. C. Powell, New York; F. Lewald, Chicago, and S. K. Skidmore, representing C. B. Rouss, New York.

The petition of Albert A. Remington, assignee of the Campbell-Metcalf Silver Co., for additional compensation for his services as such assignee to that allowed by statute, and allowance for counsel fees, having been referred to Lorin M. Cook, Register in Insolvency, by Court, with directions to inquire into the subject matter of said petition and to report to said Court whether the petitioner is entitled to additional compensation for his services and allowance for counsel fees, and, if so, in what amount, all creditors are notified that Mr. Cook has appointed Wednesday, Jan. 17, 1900, at 10 o'clock A. M., as the time, and his office, 17 Custom House St., Providence, R. I., as the place, when and where he will hear all parties interested in the petition.

H. P. Mason, Topeka, Kan., has generally remodeled his store and added new fixtures.

## The Attleboros.

### TRADE OUTLOOK.

A blaze of glory and prosperity. That is what the jewelry manufacturers of the Attleboros expect of the year 1900. Looking back upon the unparalleled prosperity of 1899 they anticipate even greater from the closing 12 months of the century. The Christmas rush and the regular Fall crop of business all acknowledge to have been very large. The factories in the Attleboros were worked early and late; two and three shifts of hands kept the machinery in operation the most of the 24 hours in every day but Sunday, and what is more remarkable this rush continued up to the very week of the holidays, and in many a house there was no time to stop for making Spring samples and no rest nor breathing space between the busy Fall of '99 and the busy Spring trade of 1900. To show something of the conditions of trade in the Attleboros and the state of mind of the manufacturers in these towns a few quotations may be interesting.

Fargo & Engley are at present the sole representatives of the aluminum business in the Attleboros. Said Mr. Engley: "We are busy now with an avalanche of orders on advertising novelties for western retail houses of all kinds, but we see a growing movement on the part of the jewelers and jewelry jobbers to recognize our goods as kindred to theirs. At present there is little relation between our trade and the jewelry business and we are giving our attention to advertising, but in the future the two trades will work much nearer together. We are confident of a big year in 1900, for we have now six travelers out with our samples and we are fitting up our new plant to handle what they are sending us."

Smith & Crosby, representing the gold goods manufacturers, are spoken for by Mr. Crosby: "Although our gold front goods are nearly as staple as white beans, we have just passed through an exceptional 12 months. I look forward for a year equally as good in 1900 and for continued prosperity if William McKinley is returned for a second term as president."

E. T. Bright, enameler, offers a valuable word because he handles the enamel work of nearly all the Attleboro manufacturing houses. "The demand for goods decorated with enamel was very large this past Fall. The Spring samples seem to promise a big run on goods decorated with soft enamel and enamel paint instead of the more expensive sort called for in the Fall. The volume of business for Spring will be good, however, and I expect great things for the Fall of 1900."

McRae & Keeler can speak for the novelty business. Mr. McRae: "Our Spring orders are coming in greater numbers and greater volume than at this time in any preceding year. Our salesmen are all out and meeting with great success, and we have the largest working force ever employed by an Attleboro jewelry house, and this is only the beginning of the Spring trade."

In the silver goods James E. Blake, of the James E. Blake Co., declares: "I never saw such a year as we have just passed; I never saw a new year begin with such a rush. The interval between the Fall and Spring seasons was only four days and then we had to get right down to business again, and we can hardly handle our orders."

A representative house making ladies' goods is F. W. Weaver & Co. "We only hear one story in our office: last year was big, this year will be bigger," from Frank W. Weaver.

The Bay State Optical Co. are Attleboro's branch of the optical industry. "From all the information we can get from sources we consider reliable and from our own brief experience we expect a big year in 1900. Our advance orders are unusual in number and size, and we only see one drawback, that the competition of new optical houses is trimming down the margins of profit on our style of goods."

Said Captain Herbert A. Clark, of the Horton, Angell Co.: "The Fall trade ran right up to the Spring trade this time, a very unusual thing with us. We are already getting heavy orders for our new samples and see a very prosperous year before us unless all signs fail."

Sidney O. Bigney, of S. O. Bigney & Co., chains, declares: "The outlook is remarkable. 1900 is just begun and we have to-day 50 more hands at work than ever before."

Perhaps the only branch of the trade which has closed its busy season and is for the moment resting on its arms is the emblem business and goods in this class. The emblem busy season of 1899, however, was a wonderfully prosperous one, and

a better one is looked forward to. The centennial year will contain an unusual number of events calculated to boom the souvenir and emblem trade. All the trades in the Attleboros kindred to and dependent upon the jewelry business are very busy. The quantities of new machinery bought in the past few months have been without a parallel in the history of the town. The refiners, dealers in all sorts of supplies, and the acid men have also had a busy Fall and are stocking up for a grand rush until Midsummer.

Luther Hall, formerly of L. R. Hall & Co., was married Monday in Danielsonville, Conn.

Winter Bros. is the name of a new firm of tap and die makers who started last week in Wrentham.

F. H. Sadler & Co. and Allen, Smith & Thurston installed electric lighting plants in their factories last week.

Harold Baker has been placed in charge of the new refinery just completed and opened in Attleboro by George M. Baker, Providence.

John E. Tweedy, of Cheever, Tweedy & Co., was last week elected to the executive committee of the Massachusetts Fish and Game Association.

Last week a party of 50 employes of W. & S. Blackinton, Providence, visited George H. Holbrook, their foreman, at his Attleboro home and presented to him a gold watch.

Last week Grover, Son & Co. and Ernest D. Gilmore took respectively the north and south halves of the shop room in the Bates Steam Power building, vacated by the Daggett & Clap Co.

Gardner Whiting, foreman of Frank M. Whiting & Co., North Attleboro, and prominently connected with the head of the firm, celebrated the 30th anniversary of his marriage last week.

P. J. Cummings & Co. have taken the section of the W. H. Wilmarth factory recently vacated by C. A. Marsh & Co. They begin the new year with over 10,000 feet of floor space, more than double their former plant.

Ernest Dean appeared in the Attleboro district court Saturday and pleaded guilty to the charge of larceny from J. F. Sturdy's Sons, Attleboro Falls. The plunder was \$150 worth of unfinished plated chains taken in the middle of November last. Owing to Dean's plea no evidence was taken and the prisoner was sentenced to one year in the house of correction.

The removal of R. Curtis Read from Attleboro to New York last week to assume charge of the New York office of J. C. Cummings & Co. led to a change in Attleboro Masonic circles. He resigned his position as senior warden of the Attleboro lodge and it was filled by the choice of Carl V. J. Christensen, manager of the United States Automobile Truck Co.

Among the jewelry buyers who the past week placed large orders with the local manufacturers were: John B. Ash, Rockville, Ill.; Sol Cerf and M. Bonn, Pittsburgh; Mr. Kirby, Pittsburgh Dry Goods Co.; Mr. Myers, Canadian Importing & Trading Co., Montreal; H. F. Power, New York; A. H. Beal, Boston; Mr. Lewald, F. Lewald & Co., Chicago, and J. and B. C. Silver, Montreal.

Field & Briggs, who have been doing business in the Bushee building, dissolved partnership last week. Oscar D. Briggs,

the junior partner, has assumed control and will continue the plant in operation. He has associated with him Harrison C. Swift, the head of the mail order house of the Curtin Jewelry Co., as partner. Everett H. Field, the retiring partner, will enter the jewelry business in Providence, which is his home.

**Alabama Notes.**

Speaking of their business, Montgomery jewelers report as follows:

J. A. Weiss—"My business has increased at least 25 per cent over last year. The increase in the sale of higher grade goods is remarkable."

I. Loeb, who has been there only five months, having moved from Selma and succeeding to the business of William Black, who moved to New York—"I have done much better than I expected."

H. Ruth, speaking for C. L. Ruth—"The trade

has been beyond our expectations. In our 26 years of business in Montgomery, 1899 was by far the best."

A. W. Lebron—"My business has increased 300 per cent over last year."

E. R. Freeman is now doing business as a watchmaker and jeweler at Russellville.

A. Speaker has moved his place of business from the First National Bank building to 220 21st St.

**Kansas City.**

Louis A. Jcanneret, Kansas City, Kan., has sold real estate valued at \$500.

C. L. Merry has started to remodel his shop preparatory to adding considerable new machinery and greatly enlarging his capacity.

**Just Why**

Certain watches will come higher hereafter we will not now attempt to explain in detail. Perhaps the law of supply and demand has something to do with it.

**Just Why**

You can well afford to look to us for watches WE CAN EXPLAIN.

**CAREFUL PREPARATION.**

**FACILITIES UNSURPASSED. STOCK ALWAYS COMPLETE. LOWEST POSSIBLE PRICES. SERVICE PROMPT and CAREFUL.**

To this add an uninterrupted and unassailable record of thirty-two years, and you will admit that there is nothing lacking in our credentials.

**C. G. ALFORD & CO.,**

195 and 197 Broadway,

January 10, 1900.

NEW YORK, N. Y.

## Our Traveling Representatives



Traveling representatives may consider these columns open for the publication of any news or items of interest regarding themselves or their conferees.

John Hagan, the western representative of E. L. Spencer & Co., Providence, R. I., has the sympathy of the trade in his bereavement caused by the death of his wife on Tuesday of last week.

M. Mannist, for several years with Greenberg & Glaser, New York, is now with L. W. Rubenstein, 54 Maiden Lane, New York, for whom he covers the eastern and central States.

J. M. Hills, of Brooklyn, N. Y., is a new salesman for William Nerney & Co., Attleboro, Mass. Arthur J. Wilson has accepted the position of western salesman for J. C. Cummings & Co., Attleboro, Mass.

E. A. Bigelow, New England manager of the Courvoisier-Wilcox Mfg. Co., and G. Frank, Sussfeld, Lorsch Co., were in Toronto, Ont., last week.

Earl B. Smith is the new salesman for Fontneau & Cook, Attleboro Falls, Mass., appointed last week. He will cover the New England and New York circuit.

Engene Frohmyer, representing L. Gutman & Sons, Cincinnati, O., celebrated his first wedding anniversary at his home with a large number of friends participating.

H. C. Pfaffle, one of the best known travelers through the southwest, now connected with L. Gutman & Sons, Cincinnati, O., has gone to Arizona on a pleasure trip of a few weeks.

John F. Logan and John B. Eason, traveling representatives for Ontario of the Goldsmiths Stock Co., Toronto, Ont., started on Monday on the eastern and western routes respectively.

Fred Baker, traveler for Hayden W. Wheeler & Co., New York, likes Detroit so well that he has moved his family there, and will make that city his permanent home. He will still represent Wheeler & Co.

W. P. Hanford, formerly with A. Roseman, New York, will hereafter represent Freudenheim Bros. & Levy, 54 Maiden Lane, New York, through the western and middle States. E. G. Adler, with the same firm, who recently returned from a successful trip, will leave again between the 10th and 15th.

Among the travelers who recently called on Syracuse (N. Y.) jewelers were: Edward A. Coburn, Frederick Mueller & Co.; Hugo C. G. Muller, for H. Hohenstein; E. A. Porter, the Holmes & Edwards Silver Co.; Wm. Guiler, Carter, Hastings & Howe; Philip K. Hills, Hayden W. Wheeler & Co.

R. F. Simmons & Co., manufacturers of chains and bracelets, announce that, beginning Jan. 1, Geo. L. Sweet became their eastern representative, and Louis E. Fay their western representative. Unique announcements of this fact bearing at the top a half-tone portrait of the aforesaid gentlemen were sent out to the trade last week.

Traveling men in Boston, Mass., the past week included: John Thornton, Thornton Bros.; Harry Barrows, W. G. Clark, F. S. Gilbert, E. Simmons, Simons, Bro. & Co.; Harold Sweet, R. F. Simmons & Co.; Horace W. Dunham, International Silver Co.; Benjamin Griscom, Bippart & Co.; H. D. Sherrill, Sinnock & Sherrill.

Fred H. Perry, western salesman for O. W. Hawkins & Co., Attleboro, returns from a lengthy trip the latter part of this week. On his return to Attleboro he closes his connection with Mr. Hawkins and assumes the grip for the W. H. Wilmarth Co. His present employers will be represented for the time being by Mr. Hawkins himself.

It is possible that within a short time changes of importance will be effected in the rooms of the Manufacturing Jewelers' Salesmen's Association. There is talk of installing billiard and pool tables and making other additions calculated to tend toward making the time pass more pleasantly for the salesmen while in the rooms. As yet no meeting

has been held to decide upon this matter, but it is probable that one will be called within a short time.

Allsopp Bros., 60 McWhorter St., Newark, N. J., have engaged the services of C. H. Anderson, formerly with M. B. Bryant & Co., who will represent them in the south and west. Fred T. Long, as formerly, will represent the firm in Boston and the east, as well as in Philadelphia, Baltimore and Washington; Joe D. Varley, in Pennsylvania and part of New England; E. E. Spaulding in the northwest and territory to the Rockies.

Travelers in St. Louis, Mo., last week were: H. B. Richardson, G. A. Dean & Co.; Wm. W. Middlebrook, B. A. Ballou & Co.; Chas. B. Bartlett, Whiting Mfg. Co.; Geo. L. Paine, E. I. Franklin & Co.; S. C. Howard, Dominick & Haff; G. A. Jewett, Hamilton & Hamilton, Jr.; B. B. Brady, B. B. Brady & Co.; Wm. F. McGown, Chapman & Barden; T. J. Kilkenny, T. J. Kilkenny & Co.; I. J. Sommer, Sommer & Mills Co.; Mr. Ripley, Watson, Newell Co.; Mr. Edwards, W. H. Bell & Co.; C. H. Cooke, C. H. Cooke Co.; Edward Luther, Smith & Crosby; Wm. Wightman, H. D. Merritt & Co.

Travelers in Pittsburgh, Pa., last week were: Mr. Kennon, John T. Mauran Mfg. Co.; Mr. Hodgins, Tarrant & Gismond; F. R. Sheridan, Horton, Angell Co.; S. C. Howard, Dominick & Haff; H. C. Rowbotham, C. P. Goldsmith & Co.; G. L. Sweet, R. F. Simmons & Co.; E. R. Bennett, for S. A. Bennett; E. W. MacAllister, Irons & Russell; Charles W. Hempel, Sandland, Capron & Co.; W. I. Schloss, Follmer, Clogg & Co.; J. G. Fuller, Fuller, Carpenter & Co.; Mr. Williams, Arnold & Steere; George L. Paine, E. I. Franklin & Co.; Louis Hirsch, Hirsch, Flashner & Robbins; C. E. Settle, H. J. Hildebrand, Mr. Heyman, Stern Bros. & Co.; T. H. B. Davis, International Silver Co.; George Southwick, Union Braiding Co.; S. H. Fink, Fink, Bodenheimer & Co.; Arthur Bradshaw, Meriden Britannia Co.; Dan Wile, Buffalo Jewelry Case Co.

Traveling representatives who visited the trade in Indianapolis, Ind., last week were: Harry B. Kennion, Parks Bros. & Rogers; Harry J. Hildebrand, H. C. Lindol & Co.; Herbert Bliss, Bliss Bros.; G. A. Jewett, Hamilton & Hamilton, Jr.; J. F. Ripley, Watson, Newell Co.; D. N. Jacoby, Providence Stock Co.; H. B. Richardson, G. A. Dean & Co.; Mr. Steere, Geo. L. Brown & Co.; Mr. Cook, Fontneau & Cook; Milton S. Rodenberg, Rodenberg & Dunn; F. W. MacAllister, Irons & Russell; J. G. Fuller, Fuller, Carpenter & Co.; F. N. Vassetz, Fletcher, Burrows & Co.; F. B. Brigham, Cheever, Tweedy & Co.; G. L. Sweet, R. F. Simmons & Co.; S. H. Brower, R. L. Griffith & Son Co.; N. F. Swift, for G. K. Webster; J. S. Platt, Theodore W. Foster & Bro. Co.; Geo. H. Remington, Waite, Mathewson & Co., and C. R. Harris.

Eastern men in Cincinnati, O., Saturday were: W. P. Stowe, W. H. Wilmarth Co. This is Mr. Stowe's last trip this year, as he will after this make only annual trips. Nate Swift, for G. K. Webster; George W. Platt, Theodore W. Foster & Bro. Co.; A. B. Chace, for F. S. Gilbert; Mr. Barbour, Plainville Stock Co.; Mr. Scofield, Scofield, Melchor & Scofield; Mr. Middlebrook, B. A. Ballou & Co.; C. E. Settle, for O. M. Draper; H. B. Kennion, Parks Bros. & Rogers; Mr. Oakley, Thornton Bros.; Mr. Wightman, H. D. Merritt & Co.; Mr. Luther, Smith & Crosby; Sam Brower, R. L. Griffith & Son Co.; George Caldwell, Lenau, Thomas & Co.; Mr. Sheridan, Horton, Angell Co.; W. E. Hayward; Mr. Goldberg, W. & S. Blackinton; Gus Strandberg, Sykes & Strandberg; Mr. Richardson, G. A. Dean & Co.; B. Brady, Mr. Rounds, Hancock, Becker & Co.; Cheever Hudson, G. C. Hudson & Co.; Mr. French, Riley, French & Heffron; George L. Paine, E. I. Franklin & Co.; H. Kent, F. W. Weaver & Co.; E. L. Mumford, Waite, Thresher Co.

### Death of Dwight C. Callender.

WATERTOWN, Conn., Jan. 8.—Dwight C. Callender, 57 years of age, one of the most respected citizens, died of pneumonia this morning at about 7 o'clock. The deceased was formerly engaged in the jewelry business at Waterbury, occupying the store now held by Lake & Strobel Co. About 14 years ago he bought a farm and settled in Watertown, where he has lived up to his death.

## Boston.

### TRADE CONDITIONS.

A few of the Boston jobbers have been taking account of stock the past week, but most of them wait until February before sizing up their annual fiscal report. Some of the retailers, however, have evidently looked over their accounts and found them very unsatisfactory, for a number of assignments are reported. Boston is not alone in this respect, moreover, for Boston jobbers hear unpleasant news from a few of their New England customers also. The holiday season, as a whole, however, has been pretty active and the failures are not of discouraging scope and character. Business, as usual in January, is quiet, most of the orders being of the "stock replacing" type, but the outlook has many hopeful aspects and the jewelry trade of the Hub begins the new year with cheerfulness as a rule.

T. Frank Bell, who has assigned to Charles E. Medbury, has liabilities of about \$25,000, with assets nominally equal in amount.

Among the visitors to Boston within a few days was J. L. Sweet, of R. F. Simmons & Co., much improved in health and appearance, and he was warmly welcomed by his many friends, this being his first appearance among them in a long while.

Benjamin French, one of the pioneer importers of lenses for photography into the New England market, died last Wednesday at the ripe age of four score years. He had been in failing health for some time, and practically retired from active business.

Alfred M. Hinds, representing Dueber-Hampden Co., has been here over the holidays in quest of high class workmen for the watch factories at Canton, which are enlarging their output and requiring additional hands to carry out their plans in this respect.

At a meeting of the creditors of A. S. Adams, 8 Winter St., held Jan. 2 at the rooms of the Boston Merchants' Association, Mr. Adams submitted a statement of his business condition, and the creditors decided to grant him an extension of time for payment in full on his accounts.

The fact that W. B. Knapp has given up his quarters on Temple Pl. has led to various rumors regarding his whereabouts, but it is understood that he contemplates settlement in the United States Court, under the national bankruptcy law, and his future business arrangements will not be made until the case is heard therein.

Gardiner, Me., reports two business embarrassments in which Boston dealers are interested slightly. George L. McKenney, of Gardiner, assigned to O. B. Clasen. His indebtedness is about \$600, secured by mortgage and \$650 unsecured. He offers 25 cents on the dollar. Cohen & Langille, of Augusta and Gardiner, offer 20 cents on the dollar to their creditors.

Horace Partridge & Co., dealers in fancy goods, sporting goods and incidentally in small lines of jewelry, have assigned. They were formerly on Hanover St., but have been located on Franklin St. for a year or more. Liabilities and assets are about \$100,000 each. Sherwin & Clarke, the Hanover St. jewelers, went down with the larger house. Both Sherwin and Clarke were formerly clerks with Horace Partridge & Co., and when the business was contracted during the depression three years ago they bought out the Hanover St. jewelry department.

# A Few Suggestions.

**Do you want** your stock of Sterling Silver Ware to embrace the identical articles that are sold by Dry Goods Stores? Having in mind that the latter are sending catalogues by the thousands to the homes of your own customers, is it not a fact that the illustration of the patterns in your stock in such Catalogues makes these goods undesirable for the finer class of your patrons? Is it not true that a person of taste, desiring to make a Wedding Anniversary or other complimentary gift, would hesitate to send an article generally found in Dry Goods and Department Store Catalogues?

**If these are facts**, why not confine your purchases of Silver to the Manufacturers who deal only with the legitimate Jewelry trade, thus protecting your interests and preserving the fashionable exclusiveness of the wares in your stock, so often a feature in consummating an important sale? The productions of the **Gorham Mfg. Co.** are never sold except through the best class of Jewelers.

**They are fashionable.**

**They are exclusive.**

**Their quality is unquestioned.**

**They are not higher priced.**



## Gorham Mfg. Co.,

...SILVERSMITHS...

Broadway and  
19th Street, New York City.

BRANCHES:

NEW YORK:  
21 & 23 Maiden Lane.

CHICAGO:  
131-137 Wabash Avenue.

SAN FRANCISCO:  
118-120 Sutter Street.

WORKS: PROVIDENCE, R. I., AND NEW YORK CITY.

OTTO K. TREIBS.

PAUL E. TREIBS.

**TREIBS BROS.,**

68 Nassau St., New York.

139 Mathewson St.,  
Providence, R. I.

CUTTERS AND IMPORTERS OF

**Opals.****F. E. TREIBS,**

Oberstein, Germany.

ESTABLISHED 1842.

HERMANN TREIBS.

ALBERT TREIBS.

EMIL TREIBS.

**Vrieslander & Moreels,  
Commission Merchants.****We buy Rough Diamonds  
for 1 per cent commission.****We cut Melées specially  
for the American market.**Best New York References.  
Correspondence Solicited.

Temporary address,

5 Rue Van Lier,

ANTWERP, BELGIUM.

**Philadelphía.****TRADE OUTLOOK.**

The local jewelry trade during the past week has largely been given over to stock inventorying, and new business has been comparatively light, though unexpectedly stronger, merchants say, than last year. Business will likely be renewed with considerable spirit during the next fortnight. The situation from the viewpoints of both the manufacturing and retail jeweler seems encouragingly strong.

Pottstown jewelers have agreed to close their stores at 6 o'clock, instead of 10 o'clock, as hitherto.

Alfred M. Githens, the noted engraver, has made a design for a new seal for the University of Pennsylvania.

W. Herzberg and P. Abrams gave gold watches to the most comic New Year's Club parading in front of their stores.

David S. Woodruff, jeweler, 1604 Pine St., has associated himself in business with his two sons, Isaac N. and David S. Woodruff, Jr.

The Holly Mfg. Co. were incorporated in Harrisburg last week with a capital of \$20,000 for the manufacture and sale of novelties.

There was to be a meeting of the Pennsylvania State Optical Society yesterday to make preparations for the examinations to be held next month.

There has been listed on the Philadelphia Stock Exchange \$1,080,000 common and \$2,160,000 preferred stock of the Keystone Watch Case Co.

The Montana Diamond Co., of America, with a capital of \$100,000, Saturday filed articles of incorporation in the Camden (N. J.) County Clerk's office.

Frederick Reichwein, jeweler, has made an assignment for the benefit of his creditors to Samuel Kind. The deed is dated Jan. 4, and conveys no real estate.

Whitehall, Tatum & Co., of Millville, have received a big order for cut glass ware from Honolulu. The firm consider this as a material echo from the National Export Exposition.

Jules Hertel, secretary of the Horological Society of Philadelphia, has resigned as head of the watch repairing department of Wanamaker's store and has been succeeded by Henry Wright, formerly of Washington, D. C.

The Horological Society of Philadelphia held a meeting Thursday at Bank Hall, Broad and Columbia Ave. Many members seem to have lost interest in the proceedings of the society. The meeting was not well attended.

In making a resume of the commercial conditions of 1899 Dr. Wm. P. Wilson, of the Commercial Museums, says the exportation of jewelry, watches and glass ware from this country to foreign markets has increased 30 per cent.

Bailey, Banks & Biddle Co. made the handsome solid silver tea set last week presented to Sheriff Hartman by his old colleagues in Common Council. Other mementos presented by other city officials were made by the same firm.

M. B. Markland, jeweler, 802 Walnut St., has accused Benjamin Blitz, 11th and Berks Sts., with the larceny by bailee of three diamond rings worth \$281, which, it is stated, he obtained on a memorandum from Mr. Markland. Blitz has been held for a hearing.

Among the retailers who visited the local jobbers last week were: F. H. Fite, Girardville, Pa.; S. R. Snyder, Clearfield, Pa.; S. M. Smith, Woodstown; E. S. Schofield, Millville, N. J.; F. C. Maag, Bridgeport, Pa.; Charles Kohler, Norristown, Pa., and Captain Bowen, of Bridgeport, N. J.

The Philadelphia Jewelers' Club met Jan. 9 to nominate officers to be elected to serve during the ensuing year. It is presumed all the old officers will be re-elected except possibly the secretary, James W. Barry. Wm. Quinn, with H. Muhr's Sons, was the most popular candidate for the office.

Frank Stone, a confidential clerk in the jewelry store of George E. Sattler, 2052 N. Front St., has been arrested on a charge of stealing silver ware, umbrellas and fancy articles from the store. The arrest was made through the instrumentality of Mrs. John Stevens, with whom Stone boarded and who found a lot of pawn tickets in his bureau.

B. Frank Williams, wholesale jeweler, who, while trading under the name of D. F. Conover & Co. was adjudged a bankrupt about two years ago, has filed an application with the United States District Court for his discharge. Jan. 19 has been chosen for the hearing. Mr. Williams is represented by Thomas McConnell, Jr., 133 S. 12th St.

Thomas Brainard Myerle passed away in West Chester, Pa., a few days ago, after an illness of several weeks, with a complication of heart troubles. He was 62 years of age. For many years the deceased had been engaged in the jewelry business in Philadelphia. During the past year he had been in the service of Simons, Bro. & Co. In his early life he resided in the south.

About 15 jewelers of the Philadelphia Jewelers' Club accepted the invitation of the New York members to attend a theater and supper party to be given in that city Saturday night, Jan. 6. Among those who went were J. Warner Hutchins, Wm. S. Sackett, Wm. Long, Joseph Cadwailader, Wm. Bruehl, L. P. White, Wm. Quinn, Wm. Fullerton, Charles Thomas and Zophia Laird.

James Allan & Co., wholesale and retail jewelers, Charleston, S. C., in replying to the query made by a local concern whether or not it would be more advantageous to buy direct from Philadelphia, have written: "We appreciate the Philadelphia progressive manufacturing center, but we are much more interested in seeing the manufacturing and jobbing centers of the South developed, and would far rather encourage our people in that direction."

**Newark.**

The Jewelers' Protective Union of Newark will hold their meetings in the future every first and third Friday evenings of each month at 8 o'clock at their headquarters, 128-130 Mulberry St.

The articles of incorporation of the John J. Jackson Co., who will manufacture gold plated metal and sterling silver ware, were recorded with the County Clerk Jan. 4. The capital stock is \$25,000, all of which has been paid in by Emily A. Jackson, James H. and De Witt C. Bolton. The concern will do business at 91 Mechanic St.

**STERLING  
SILVER  
GOODS ONLY**



**FRANK M. WHITING & CO.**

**SILVERSMITHS**

**NORTH ATTLEBORO  
MASS**

1128 B'WAY, NEW YORK.  
220 SUTTER ST. SAN FRANCISCO.



**Death of James Hamblet.**

James Hamblet, well known to the horologists as the manager of the Western Union Time Service, died Tuesday, Jan. 2, at his home, 20 Sydney Pl., Brooklyn, N. Y. Death was due to pneumonia, although Mr. Hamblet had been ailing

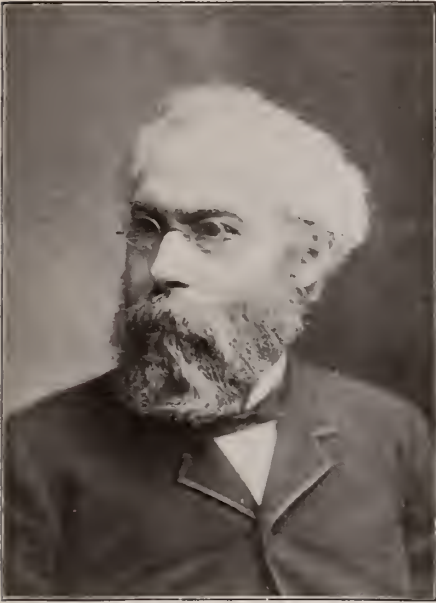

THE LATE JAMES HAMBLET.

since last Fall. The deceased had spent his entire life in electrical and horological work and in the application of electricity to horology had attained a pre-eminent position.

Mr. Hamblet was born in Boston, Mass., Jan. 16, 1824, and was the descendant of old New England stock. When a young man, he obtained his first position with Wm. Bond & Son, celebrated watch, chronometer and astronomical and nautical instrument makers of Boston. With them he remained from 1853 until 1862, when he started in business for himself as a manufacturer of electric and telegraphic instruments. This business he gave up in 1870 to go with E. Howard & Co., clock manufacturers, Boston, and his work during the six years with that concern is well known to the clock trade. He left the clock business in 1876, going to California for the Electrical Construction Co. After two years he returned to New York and established the time service for the Western Union Telegraph Co. He became manager of this department and through his work raised the time service to its high state of perfection to-day, retaining his position until the time of his death.

Mr. Hamblet was a deep student in

horology and among his productions in this line is the standard clock used in the Western Union time service, which is connected with the National Observatory clock at Washington and which acts as a master clock for the company's self-winding system. It was, however, in the electrical world that the deceased obtained his greatest prominence, and in the particular lines in which he was engaged no man in the United States had a higher reputation. Mr. Hamblet was in touch with the leading electricians of his day and was one of the oldest friends of Thomas A. Edison. He became acquainted with Edison at Boston in 1868-1869, when the latter first came from the west as a young man, and to Mr. Hamblet the celebrated "Wizard" was indebted for many points of instruction in his early career. Mr. Hamblet obtained, through his careful and studious work, many positions of distinction; among them, he was for many years manager and vice-president of the American Institute of Electrical Engineers and was prominent as a member of the New York Electrical Society, the oldest society in its line in the metropolis; and for the 10 years preceding his death was president of the electrical department of the Brooklyn Institute of Arts and Sciences.

For many years Mr. Hamblet had been a resident of Brooklyn and had become prominent in the church work of that city, where he was head usher and clerk of the vestry of St. Ann's P. E. Church. The deceased is survived by a widow and one daughter. The funeral services were held at 5 o'clock P. M., Thursday, at his late residence, and were conducted by the Rev. Dr. Reese F. Alsop, of St. Ann's Church. The remains were forwarded to his native home, Boston, and were interred at Wood Lawn, near that city.

#### Washington Jewelers Suffer Through the Operations of Thieves.

WASHINGTON, D. C., Jan. 5.—Jewelry robberies seem to be the order of the day in Washington. Warren Hartman, 19 years of age, was arrested this week for stealing from his employer, Andrew O. Hutterly, jeweler, 632 G St., N. W. He had been in the employ of Mr. Hutterly for about a year. Although young, he was considered to be a valuable assistant and his pilferings were carried on entirely without the knowledge or suspicion of his employer, his arrest being due to the fact that the detectives had ascertained that he was disposing of watches and rings. He admits having taken eight watches, eight rings, a gold pen, part of a pair of gold spectacles and several other articles which the police have not yet recovered. The boy will probably have to answer to 17 counts of petit larceny.

About three years ago it was reported in THE CIRCULAR that Gerome Desio, jeweler, F St., had been robbed of a tray of jewelry containing diamonds valued at about \$3,000. Last week a man by the name of Charles E. Hoyt was taken from Boston to Pittsburgh, to answer to the charge of implication in a diamond robbery at A. E. Siedle's store, in the latter city, in December last. While Hoyt denies the charge, he admitted where the diamonds could be found in Brooklyn. Mr. Desio has been to Pittsburgh and has identified Hoyt as one of the gang that visited his store at the time named, the other members of the gang being James Reilly and William Sullivan, both of whom have since been convicted of complicity in a diamond robbery in Pennsylvania. An effort will be made to bring Hoyt to Washington, but it is thought to be doubtful that the Pittsburgh authorities will give him up, as he is wanted to answer in that city for several crimes.

The store of D. N. Walford, 477 Pennsylvania Ave., dealer in jewelry and cutlery, was broken into Monday night, entrance being effected by breaking one of the show windows. Seventy-two gold plated rings, valued at \$320, rewarded the marauder's efforts. No arrests have yet been made.

#### James Baxter, Once Accused with Smuggling Diamonds, Arrested.

Word was received in New York on Thursday that one James Baxter had been arrested in Montreal, Canada, in connection with the Ville Marie bank failure, and that this Baxter was wanted by the United States authorities in connection with a diamond smuggling charge. The only Baxter known to have been charged with diamond smuggling of recent years was the James Baxter, of Montreal, who was arrested in New York in April, 1896, and who escaped from the custody of Treasury agent Jas. H. Hefferman while the latter was taking him to the northern district of New York, where the crime was committed. This Baxter left Canada on March 30, 1896, and was followed by Hefferman to New York. Here Hefferman seized a package of 22 diamonds which he had in his possession. The Treasury agent left for the northern part of the State with Baxter, who escaped from his custody. Hefferman was a short time later removed from his position by the Secretary of the Treasury. No information about the alleged arrest of Baxter could be obtained from the United States District Attorney's office, New York, or from the Customs House.

Mrs. Fannie M. Vuille, jeweler, St. Joseph, Mo., has been sued for \$200.

## The Mercantile National Bank

OF THE CITY OF NEW YORK,

BROADWAY AND DEY STREET,

Solicits Accounts from the Jewelry Trade.

# TO RETAIL JEWELERS, WARNING

## Keep Tabs on the Tags and Swivels.

When you buy Blackinton Chains the stamps on swivels tell the story.

EACH TAG AND STAMP ON SWIVEL REPRESENTS A DIFFERENT QUALITY.

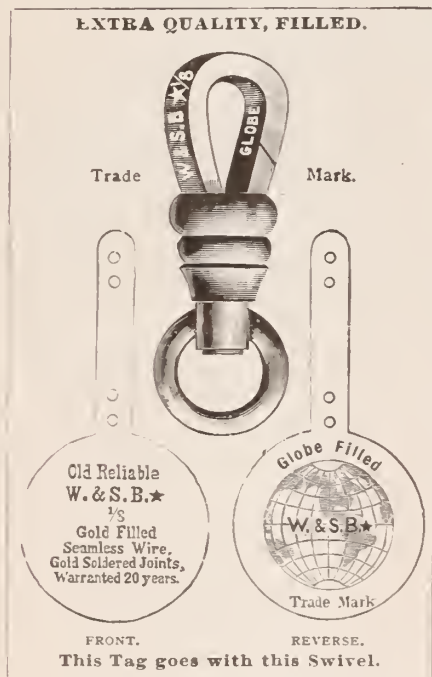

OLD RELIABLE  
**W. & S. B. ★ GLOBE FILLED**  
 ARE EXTRA QUALITY  
 AND WARRANTED TO ASSAY  $\frac{1}{8}$  GOLD.

OUR REGULAR  
**OLD RELIABLE W. & S. B. ★**  
 ARE  $\frac{1}{10}$  PLATE AND SUCH AS WE  
 HAVE MADE FOR 30 YEARS.

IF YOUR SWIVELS BEAR EITHER OF THE ABOVE TWO STAMPS YOU ARE SURE OF GETTING CHAINS THAT EXCEL IN

**QUALITY, DESIGN AND FINISH,**

THE GREATEST OF VIRTUES THAT COMBINE TO MAKE A LINE OF GOODS

**RELIABLE AND SALABLE.**

EVERY JOBBER CARRIES THESE CHAINS. INSIST ON SEEING THEM; A CAREFUL EXAMINATION WILL PROVE THE ABOVE.



MR. W. SUMNER BLACKINTON EXPLAINING THE DIFFERENT QUALITIES AS INDICATED BY THE STAMP ON THE TAGS AND ON THE GOODS.



**Each Article of this Grade is Stamped as above.**

**THIS IS OUR 2d QUALITY.**

**CAUTION**

Retailers when buying should be most careful to see that chains so stamped are not sold as either the old reliable W. & S. B. ★ GLOBE FILLED or the old reliable W. & S. B. ★. **THIS IS BEING DONE AND HAS BEEN DONE EXTENSIVELY.**

SECOND QUALITY.



Trade Mark.

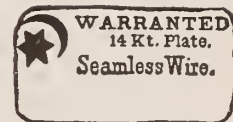

This Tag goes with this Swivel.

ALITY.

Mark.

ellable.  
S. B. ★  
Wire.

h this Swivel.

**W. & S. BLACKINTON.**

Providence, R. I.

New York, 14 Maiden Lane.

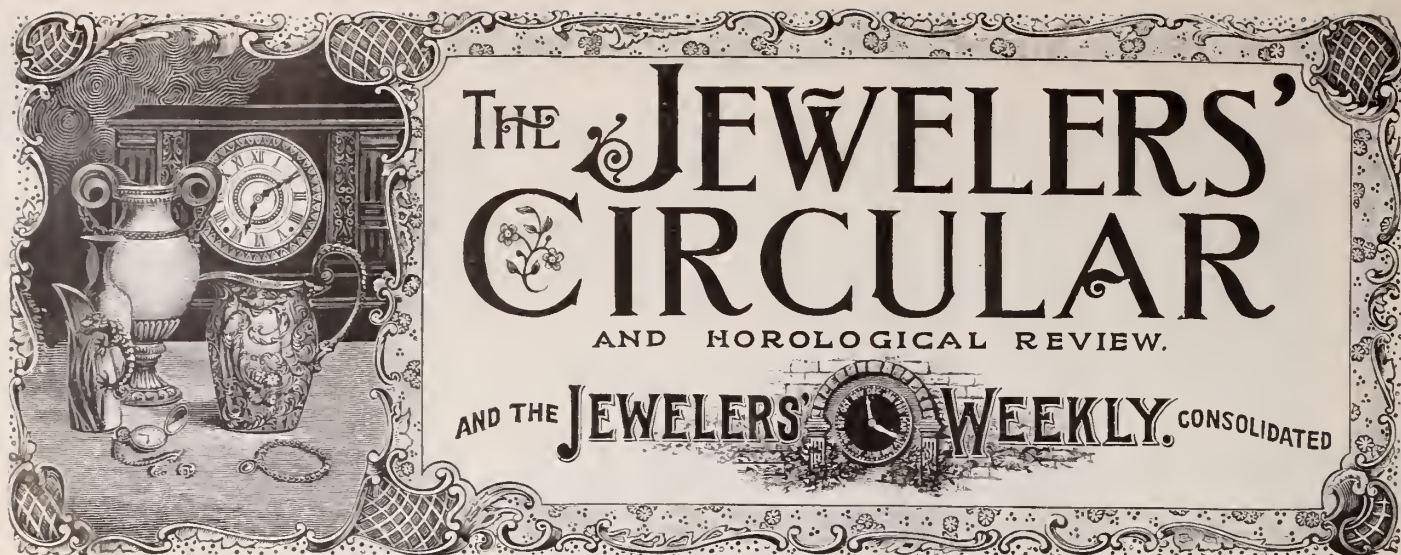

## *Announcement Extraordinary!*

The headpiece above tells a story of great interest to the entire jewelry industry. The story is there plainly told, but some fuller particulars are in order.

During several years past those connected with Jewelry Trade Journalism have become more and more convinced that the trade as a whole demands **ONE GREAT WEEKLY NEWSPAPER** to represent it; to be the chronicler of its happenings and the exponent of its best interests. It was this demand primarily that brought about the plan for the **CONSOLIDATION** of *The Jewelers' Circular* and *The Jewelers' Weekly* into one,

### **"THE JEWELERS' CIRCULAR and THE JEWELERS' WEEKLY CONSOLIDATED."**

Thus will be merged into one comprehensive journal of the jewelry industry the Oldest Publication in the trade (*The Jewelers' Circular*) and the Oldest Weekly in the trade (*The Jewelers' Weekly*). Thus to the great accumulative influence and prestige of the one, derived from 30 years of unremitting endeavor, of broad, liberal policy, of conscientious study of the trade's interests—this *The Jewelers' Circular*—will be added the prestige obtained by 15 years of equally earnest work on varying lines—*The Jewelers' Weekly*—the sum total representing a measure of usefulness of practically limitless extent.

The uniting of these two journals into one will partake of none of the features of the so-called combine. It contemplates no economies, no curtailments. It will be formed through the will of some of the most expressive minds in the trade, that *one great weekly publication* can best serve the trade; and such a paper "*The Jewelers' Circular and Jewelers' Weekly Consolidated*" will ever be. The uniting of the facilities of the two journals will result in the production of one paper so broad and comprehensive in its scope, so accurate and complete in all its details, so representative of every department of the industry that "*The Jewelers' Circular and The Jewelers' Weekly Consolidated*" will unhesitatingly be universally considered as **THE JOURNALISTIC ORGAN OF THE JEWELRY TRADE**. Such a position each, save for the other, has held, but this high place will be fortified and held impregnable for all time to come.

With its extended circulation, its inexhaustible facilities, its accumulated prestige, and last but not least its hearty and responsive endorsement by the trade, "**THE JEWELERS' CIRCULAR and THE JEWELERS' WEEKLY CONSOLIDATED**" will begin the new era of its career with potentialities for usefulness to the jewelry industry that will be exercised to the utmost.

*The consolidation will take effect with issue of Jan. 31, 1900.*

**THE JEWELERS' CIRCULAR PUBLISHING COMPANY.**

# The Jewelers' Circular

AND  
HOROLOGICAL REVIEW.

PUBLISHED EVERY WEDNESDAY BY  
**THE JEWELERS' CIRCULAR PUB'G CO.,**  
CORBIN BUILDING, 11 JOHN ST., COR. BROADWAY,  
NEW YORK.

TELEPHONE:  
1146 CORTLANDT.

CABLE ADDRESS:  
JEWELAR, NEW YORK.

A JOURNAL DEVOTED TO THE INTERESTS OF JEWELERS,  
WATCHMAKERS, SILVERSMITHS, ELECTRO-PLATE MANU-  
FACTURERS, AND ALL ENGAGED IN KINDRED BRANCHES OF  
INDUSTRY.

Member of the American Trade Press Association.

Our editorial columns will contain our own opinions only, and we shall present in other columns only what we consider of interest or value to our readers. Advertising matter will not be printed as news.

Advertising rates in THE CIRCULAR are lower, considering the number of tradesmen reached by its large circulation, than in any other jewelry journal.

Notices of changes in standing advertisements must be received one week in advance; new matter can be received up to Monday.

### INFORMATION FOR SUBSCRIBERS.

#### Terms of Subscription, Postage Prepaid.

United States and Canada, - - -	PER ANNUM	\$2.00
Foreign Countries in Postal Union, - - -		4.00
Single Copies, - - - - -		.10

New Subscribers can commence at any time.

Payments for THE CIRCULAR, when sent by mail, should be made in a Post-Office Money Order, Bank Check or Draft, or an Express Money Order or Registered Letter. All postmasters are required to register letters whenever requested to do so.

Pay money only to authorized collectors having proper credentials.

**Returning Copies.** Returning your paper will not enable us to discontinue it, as we cannot find your name on our books unless your address is given.

**Changing Address.** In changing address always give the old as well as the new one. Your name cannot be found on our books unless this is done.

**Discontinuances** We will continue to send papers until there is a specific order to stop, in connection with which all arrearages must be paid; but such an order can be given at any time, to take effect at or after the expiration of the subscription. All such orders will be promptly acknowledged by mail.

**Liability.** The courts have decided that all subscribers to journals are responsible until arrearages are paid in full and an order to discontinue has been received by the publisher.

#### THE JEWELERS' CIRCULAR IN EUROPE.

Among the places in Europe where THE JEWELERS' CIRCULAR is on file are the following:

- LONDON—First Ave. Hotel, Holborn, E. C.; Holborn Viaduct Hotel, Royal Hotel.
- PARIS—Hotel de L'Athene, Rue Scribe.
- LEIPZIG—Handels-Zeitung, für die gesamte Ubrren-Industrie.
- BERLIN—Deutsche Uhrmacher Zeitung, Jager-Strasse, 73.
- GENEVA—Journal Suisse D'Horlogerie.
- AMSTERDAM—Continental Club, Hotel Amstel.
- ANTWERP—Diamond Club, Rue de Pelican.

Vol. XXXIX. Jan. 10, 1900. No. 24.

Every line of reading matter in THE JEWELERS' CIRCULAR, with the exception of the few brief extracts from exchanges, always properly credited, is written exclusively for this journal. Each issue of THE JEWELERS' CIRCULAR is copyrighted. Permission to quote is extended to other publications provided such quotations are properly credited.

## An Event and Its Commemoration.

To inaugurate the important event in Jewelry Trade Journalism—the consolidation of THE JEWELERS' CIRCULAR and THE JEWELERS' WEEKLY—it is proposed to make the first amalgamated issue, on the date of Jan. 31, 1900, a

### Consolidation Number.

As a production of up-to-date journalism and artistic achievement, this number will be justly reflective of the occasion it commemorates. To the publishers of this journal this assertion means much. The fulfilling of the obligation thus undertaken is no easy task, but their previous marked successes in this direction warrant them in promising a commemorative number of unusual beauty, originality, interest and enduring value.

#### Against the Reciprocity Treaty with France.

THE holding up in the Senate of the proposed reciprocity treaties, so that the various contemplated changes in the tariff may be carefully studied, is in the line of wisdom. If every other industry would be adversely affected as much as the jewelry and kindred industries by the passage of the treaty with France, the measure should be entirely revised. The proposed reductions in lines comprehended in these industries are as follows:

	Present duty.	Proposed reduction.
Imitation jewelry .....	60	10
Jewelry .....	60	5
Fans .....	50	10
Articles of amber .....	25	15
“ “ bone .....	30	15
“ “ ivory .....	35	15
“ “ mother-of-pearl .....	35	15
“ “ shell .....	35	15
Buckles .....	45 to 60	10
Spectacles (averaging) .....	50	10
Lenses .....	45	10
Opera glasses .....	45	10
Watchmakers' articles .....	45	15
Clocks .....	40	15
China clocks, decorated .....	60	15
“ “ plain .....	55	15
Metal or wood clocks .....	40	15
Onyx clocks .....	50	15
Travelers' clocks .....	40	15
Clocks with wooden movements. 40		15

The decided and active opposition against the measure, put forth by the manufacturing jewelers of the east, is, as may be seen from the above table, altogether justified. While the proposed reduction in the duty on jewelry *per se* is not large, that on several lines, such as articles of amber, bone, shell, mother-of-pearl, etc., and on buckles, is considerable, and these lines are among essential products of the eastern manufacturers.

THE events now going forward in South Africa lend particular interest to the export tables relative to the commerce of the United States with that continent and to the growing demand in all its divisions for our manufactures. One of the gratifying features of our trade with that continent is the fact that the exports of clocks and watches during the 11 months ended with November increased from \$54,199 in 1898 to \$52,048 of 1899. Not only are American exports in these lines to Africa rapidly growing, but they are evidently gradually taking the place of the articles in the same lines formerly supplied by other countries. The energy with which our manufacturers have exploited the African markets is reaping results and

should be duplicated in other markets of the world.

THE last quotation (Dec. 29) on De Beers shares reported from London is 22½, which indicates vividly the Stock Exchange opinion of the position of affairs at Kimberley. Another indication of the precarious situation of the diamond city is the announcement of the secretary of the De Beers Company that declaration of dividend and publication of results of the last six months' working are deferred.

#### Henry S. Kramer Not Liable for the Orders of His Bookkeeper.

An interesting suit involving the question of the liability of Henry S. Kramer, watch material dealer, 82 Nassau St., New York, upon transactions made in his name by his former bookkeeper, Meyer Goldstein, came up for trial Monday before Judge O'Dwyer, in Part IV, of the City Court, New York. As already published in THE CIRCULAR, Kramer accuses his former bookkeeper of forgery and grand larceny and a warrant has been out since Goldstein escaped, in the early part of November. Goldstein obtained from many firms, among whom are B. H. Davis & Co., Oppenheimer Bros. & Veith, Chester Billings & Son, Eichberg & Co., diamonds and jewelry to an amount estimated at about \$10,000, and these transactions were made in the name of his employer, Kramer. The suit tried Monday was a test case brought by B. H. Davis & Co. against Kramer to determine whether or not he was liable for his bookkeeper's acts. The action was to recover \$585, being the balance on an account of \$885 on which had been paid \$300.

The question before the Court was mainly whether in the transactions between Goldstein and B. H. Davis & Co. the former was acting as the agent of Kramer, and whether or not Kramer had ever sufficiently authorized Goldstein to act for him and become liable for these transactions. After a trial lasting two hours the case went to the jury, who brought in a verdict in favor of Mr. Kramer.

Goldstein, whose acts were the cause of this suit, has not yet been arrested, although detectives are looking for him.

Henry J. Cain, vice-president and general superintendent of the Hamilton Watch Co., has been given up by his physicians, who expect his early demise.

### Trade-Mark Information.

**Note.**—The publication of our work, "Trade-Marks of the Jewelry and Kindred Trades," containing over 2,250 marks, all told, the accumulation of various works of reference and the ramifications of our business enable us to trace to their origin nearly all marks that may be found on jewelry, silver ware, art pottery and kindred lines, of both American and foreign make. All questions in regard to trade-marks will be cheerfully answered. We would be pleased to have the trade seek the benefit of our facilities regarding the identity of any marks they cannot trace. We would prefer to receive the article for examination; for if the mark is of foreign origin, the slightest difference between a drawing and the original is of great importance.

No question is too trivial nor too complicated for consideration under this department.

SCHENECTADY, N. Y., Jan. 3, 1900.

Editor of THE JEWELERS' CIRCULAR:

Can you tell us who makes plated ware with the trade-mark "W" in a cob web, the letter in the center of a star in the cob web? We have looked through the back of trade-marks and fail to find



it. Would not trouble you, but we want very much to get some of this make of goods. Will you kindly answer soon? Yours truly,

J. W. SANDERS.

**ANSWER:**—This trade-mark is that of E. G. Webster & Son, 622-30 Atlantic Ave., Brooklyn, N. Y. This trade-mark has

been recently registered, and accompanied by the word "Sterling" appears on page 50 of "Trade-Marks of the Jewelry and Kindred Trades," published by the Jewelers' Circular Pub. Co. We will say to correspondent and to all others that inquiries cause us no trouble and that we are pleased to do our best to answer any questions that he or anyone else may put to us at any time.

MILFORD, Mass., Jan. 3, 1900.

Editor of THE JEWELERS' CIRCULAR:

Will you kindly forward the enclosed nail file to the manufacturers with the request that they furnish new file same shape as old one? We cannot quite make out the mark so could not find it in your book. We enclose postage. Thanking you for the favor in advance, we remain,

Yours truly,

C. W. WILCOX,  
B.

**ANSWER:**—The article bore an imperfect impression of the stamp here shown,



which belongs to John W. Reddall & Co., 54 McWhorter St., Newark, N. J. The mark appears on page 16 of "Trade-Marks of the Jewelry and Kindred Trades," published by the Jewelers' Circular Pub. Co.

A party brought into THE CIRCULAR office an enameled, silver-gilt lorgnette bearing the stamp in next column and requested the name of its manufacturer.

**ANSWER:**—This mark is used by Krenmentz & Co., 47 Chestnut St., Newark, N. J., and 182 Broadway, New York. The

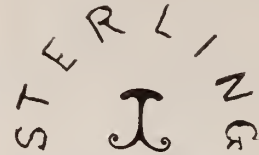

mark as used on gold jewelry is reproduced in "Trade-Marks of the Jewelry and Kindred Trades," published by the Jewelers' Circular Pub. Co.

A party brought into THE CIRCULAR office an inkwell, silver mounted, bearing this stamp:

**B S C STERLING**

and desired the name of its manufacturer.

**ANSWER:**—This article was made by the Barbour Silver Co., Hartford, Conn., who are embodied in the International Silver Co., Meriden, Conn.

A party brought into THE CIRCULAR office an engraved silver spoon stamped as below minus



the words "trade-mark" and "sterling," and a piece of jewelry stamped as below, and desired the



names of the manufacturers of the respective articles.

**ANSWER:**—The mark on spoon was owned by the Syracuse Silver Mfg. Co., Syracuse, N. Y.; while that on the jewelry is used by A. J. Hedges & Co., 6 Maiden Lane, New York. The marks are to be found in "Trade-Marks of the Jewelry and Kindred Trades," published by the Jewelers' Circular Pub. Co., on pages 49 and 13, respectively.

#### A Denial of Importance to the Optical Trade.

In the early part of last month a report was circulated by the daily New York and out-of-town newspapers to the effect that the Le Maire Optical Co., of Paris, were to be incorporated in New York and establish two factories in the United States. This report was investigated by THE CIRCULAR and, as told in the issue of Dec. 20, proved to be without foundation, so far as could be learned in the optical trade in this country. The Le Maire Optical Co. referred to, a CIRCULAR reporter learned, were a small concern who had an office at 32 E. 23d St. A denial that there was any relation between this concern and the Paris Lemaire concern came to this country by cable on Jan. 5. This cablegram, published in another part of this issue, was sent by Gladston & Barry, one of the largest optical houses in Paris, to Harris & Harrington, 32 Vesey St., New York, and is to the effect that the senders had been authorized by the Lemaire concern of Paris to denounce the report of the connection of the name of Lemaire with the interests of the establishment of the Le Maire Optical Co. in the United States.

## ON MEMORANDUM

After the Holiday Clean-out



*Your cases need filling up. We will send you on approval anything you want in diamonds and diamond jewelry to fill up. There's no question that prices will go still higher, so you'll be the gainer if you let us know at once just what you need.*

V. W. ARING, N. Y.

## CROSS & BEGUELIN

Importers and Cutters of Diamonds and Precious Stones

43 Rue de Mestay, PARIS

Telephone, 2188 Cortlandt

17 Maiden Lane, NEW YORK

**New York Notes.**

The Empire Watch Co. have entered a judgment for \$144.15 against Julius Loeb.

S. Davidson, formerly of 44 Maiden Lane, recently removed to 14 Maiden Lane.

R. H. Martin and others have entered a judgment against Jacob Belgard for \$175.17.

S. Kaiser, the Chicago representative of Louis Strasburger's Son & Co., 11-13 Maiden Lane, is visiting New York.

J. Horowitz, diamond dealer, formerly of Fulton and Nassau Sts., has taken an office in the Diamond Exchange building, 14 Maiden Lane.

V. S. Mulford, of The Jewelers' Circular Pub. Co., and Miss Madeleine E. Day, of East Orange, N. J., will be married tonight at Grace Church, Orange.

Wm. F. Dorflinger, of C. Dorflinger & Sons, cut glass manufacturers, 36 Murray St., is a member of the Grand Jury of New York county for January.

The annual meeting of Davis Collamore & Co., Ltd., for the election of directors for the ensuing year was held at the company's office, 921 Broadway, Monday at noon.

The office of Goodman Bros., diamond dealers, Nassau St. and Maiden Lane, was closed Saturday owing to the death of the youngest daughter of Louis Goodman, of this firm.

Chas. F. Wood, of Chas. F. Wood & Co., diamond importers, 1 Maiden Lane, became a grandfather on the first of the year, at the birth of the first child of his daughter, Mrs. Graden.

The annual meeting of the stockholders of the Fairchild & Johnson Co. for the election of directors for the ensuing year will be held at the company's office, 220 Fourth Ave., Jan. 15, at 11 o'clock A. M.

Bachrach & Freedman, silversmiths, recently dissolved partnership by mutual consent. The members of the firm were Abram Bachrach and Louis Freedman. Mr. Bachrach purchased Mr. Freedman's interest and will continue in business at 18 E. 17th St.

John H. Braun, assignee of Isidor Bremer, formerly a manufacturer of dog collars and novelties, has authorized a sale at auction of the machinery, stock, fixtures, etc., of the assigned estate. The sale will take place at 75-77 Duane St., Jan. 16, at noon.

A special meeting of the stockholders of the Symphonion Mfg. Co. has been called to take place at the office of the company,

110 W. 32d St., on Jan. 29, at 2 o'clock P. M., for the purpose of voting upon the proposition to increase the capital stock of the concern from \$200,000 to \$300,000.

Chas. Fouck, watchmaker, was arrested at College Point, L. I., on a charge by Geo. Weber and Martin Wharlin that he had failed to return gold watches left by them for repairs. He was arraigned on a charge of grand larceny, and to Magistrate Connorton he admitted that he had pawned the watches, but said that he intended to take them out again. Fouck was held in \$500 bail for the Grand Jury.

R. Rhode, for the past 13 years with Bawo & Dotter, 32 Barclay St., has been annoyed through the confusion of his name with another in the announcement made recently by a trade paper that R. Rhode had made business connections with an up-town house. Mr. Rhode desires to assure his friends in the trade that the person referred to is not he, and that he has no intention of severing connections with his present employers.

The New Yorker Uhrmacher Verein held their annual meeting Wednesday night at 193 Third Ave. No officers were elected as the election takes place later in the year. Among the principal business accomplished was the passing of a resolution creating what is termed a social membership, to which watchmakers who are over the age limit or who are non-residents of the State are eligible. The social members will pay the same dues as regular members and be permitted to at-

tend meetings and take part in the discussions, but will not be liable to assessments. On the other hand they will receive no sick benefits from the association.

New York China, Glass and Toy Co., of 37 and 39 Murray St., made an assignment last week to Walter P. Long. The deed of assignment is signed by Thomas P. Young, as president, and James W. Sneden. An hour later Deputy Sheriff Leavitt received an execution against the company for \$511, in favor of David P. Clark, on a judgment obtained in the City Court. The company were incorporated on April 1, 1897, with a capital stock of \$100,000, to continue the business of the J. M. Young Importing Company, which had gone into the hands of a receiver in March, 1897. A statement of the condition of the New York China, Glass and Toy Co. on Feb. 1 last showed assets, \$180,000; liabilities, \$40,000, and debenture bonds, \$40,000.

The Merchants' Association of New York have just issued in pamphlet form the annual address of Wm. F. King, president of the association, to the members. The address occupies 16 pages and touches upon many important matters taken up by the association during the past year, among which are the reduced passenger fares to New York and the results so far accomplished; the new classifications of freight rates, the express tax question, the work of the association in regard to foreign commerce, State taxes, and the 5 per cent interest bill intro-

**C. Dorflinger & Sons,**

36 MURRAY STREET,

NEW YORK,

MANUFACTURERS OF

**FINE GLASSWARE,**

desire to establish an agency in Chicago with control of middle west, in connection with some representative house in a kindred line.

1851.

1899.

**THE CHATHAM NATIONAL BANK, NEW YORK.**

CAPITAL STOCK, - - - \$450,000  
 UNDIVIDED PROFITS, - - - 974,518

GEO. M. HARD, *President.*

H. P. DOREMUS, *Cashier.*

W. H. STRAWN, *Ass't Cashier.*

duced in New York, the improvement of the Erie Canal, the work which they intend to do in regard to State commerce, the investigation of the complaints in regard to the Custom service, the question of increased post office facilities in New York and various other matters of deep interest to merchants generally. The pamphlet has been sent to all members.

J. Lassner has severed his connection with Nordlinger & Mamluck.

Rosa Nathan has sold her jewelry business at 2248 Third Ave. to J. S. Unger.

Geo. W. Shiebler & Co., silversmiths, now in the Decker building, Union Sq., have taken a lease on a store in the new building at 5 and 7 Maiden Lane, into which the firm's silver ware stock will be removed early in February.

A fire which broke out Monday afternoon at 99-101 Myrtle Ave., Brooklyn, extended to the jewelry store of Wm. Meyerhoff and did considerable damage to the latter's stock, by smoke and water. The cause of the fire is unknown. The losses are said to be all covered with insurance.

A dispatch from Wilmington, Del., Jan. 5, stated that Russell C. Parks, who said he was a jeweler of New York and the son of Samuel Parks, was married in that city to Josephine Goelet. The only Parks known in the retail jewelry trade of New York is Samuel Parks, repairer, 1330 Fifth ave.

Judge Schuchmann, of the City Court, Wednesday, vacated a service of summons upon Geo. M. Lynch, son of Mrs. T. Lynch, Union Sq., New York. The summons was obtained by Jos. M. Imfield, who does business under the style of Hendrick & Co., Newark, N. J., and was directed to Jos. D. Lynch. Geo. M. Lynch, a brother of the man named as defendant, made an affidavit that he had been served instead of his brother and the Judge vacated the service.

The reappraisal on the 900,000 imitation pearls seized from Francois Bock, by a special board appointed by the U. S. District Court, took place last week, but owing to the lack of a formality the report was not filed up to the time THE CIRCULAR went to press. The board consists, as told last week, of Alfred Krower, of Albert Lorseh & Co.; E. H. Nordlinger, of Nordlinger & Mamluck, and Meyer Goodfriend, of Goodfriend Bros. The appraisal by this board found the foreign value of the stones to be \$987.58 and the domestic value 45 per cent higher.

M. Schottlaender, a dealer in cheap jewelry who had a small store in the cellar of 59 Nassau St., failed for the second time last week. Schottlaender, it will be remembered, filed a petition in bankruptcy just a year ago and later obtained a compromise with his creditors and resumed business. On Monday last the creditors of Schottlaender received a notice to the effect that he could not pay his debts and had given up his business. According to this notice his stock had been turned over to be sold for the benefit of the creditors generally. Schottlaender's liabilities are estimated at about \$4,000.

Boehm & Coon, the owners of the building at 51-53 Maiden Lane, now known as the Jewelers' Exchange, have decided to erect a 12-story, fire-proof structure on this site. The building will be put up with the view of giving special facilities to jewelers,

by whom it is expected it will be occupied. The owners stated Saturday that they had not yet filed their plans for this building, but would do so within a short time. Boehm & Coon are the firm who erected the Diamond Exchange building, 14 Maiden Lane. The present structure at 51-53 Maiden Lane, it is said, will not in any event be torn down before May 1.

In the Jefferson Market Police Court, Saturday, Jos. Nelson, 30 years old, was charged with stealing a case of silver solvent from the Gorham Mfg. Co., by whom he was employed. The Gorham Mfg. Co. had been missing amounts of the valuable powder and reported the matter to Police Headquarters. Detectives who were detailed on the case saw Nelson leave the company's factory, Friday night, with a large wooden box. They decided to arrest him and, on doing so, discovered that the box contained solvent valued at \$300. Magistrate Poole held the prisoner to await the action of the Grand Jury in \$1,000 bail.

The schedules of Louis Combremont, dealer in watchmakers' supplies and materials, 45 Maiden Lane, who recently assigned to Purdy Van Vliet, were filed in the New York Supreme Court last week. The schedules show Mr. Combremont's liabilities to be \$10,989.75 and his assets to be nominally worth \$6,231.20 and actual worth \$2,721.96. The bulk of the liabilities are with two houses in Switzerland, \$1,098 to the Banque Fédérale and \$9,060 to Pernaud & Brodbeck, of Chaux-de-Fonds. Outside of the two items for rent, \$60 and \$319, Mr. Combremont's liabilities in this country are very small and are to 13 creditors in all, whose claims range from \$8 to \$60. His assets consist of stock, nominal value \$4,546.59, actual value \$1,794.34; accounts due, nominal value \$1,318.61, actual value \$561.62, and fixtures worth, nominal and actual, \$366.

Leigh Tannenwald, who was for seven months in the employ of E. M. Bracher & Co., wholesale jewelers, 68 Nassau St., was a prisoner in the Centre St. Police Court, Friday, charged with grand larceny. The complainant was Louis Barnett, a partner in E. M. Bracher & Co., who charged Tannenwald with the larceny of a diamond stud valued at \$65. From the story told by Mr. Barnett it seems that Tannenwald had been in the employ of the firm for four years, until October last, and had their utmost confidence. While the members of the firm were on the road, Tannenwald had the combination of the safe and was permitted to obtain goods on memorandum. Last October, the firm discovered that the prisoner had obtained articles from many firms in the name of his employers, but instead of putting these articles into stock or sending them to customers, he had pawned them and pocketed the proceeds. Tannenwald was immediately discharged. When the members of the firm came back and took an inventory of stock it showed that Tannenwald's speculations amounted to several thousand dollars, and they decided to prosecute him. His arrest followed. The specific charge against him was the larceny of a diamond stud valued at \$65, which he had obtained on memorandum from I. J. Roe, of 36 Maiden Lane, and which he had pawned. He admitted his guilt and was held for trial in \$1,000 bail.

## Last Week's New York Arrivals.

THE CIRCULAR has perfected arrangements for obtaining the names and hotel addresses of all the latest buyers visiting New York, and each day posts in its office, at John St., cor. Broadway, a bulletin which every member of the trade is cordially invited to copy.

Baltimore, Md., J. Katz, B'way Central.  
C. C. Stieff (Balt. Sterling Silver Co.), Union Square.  
Chicago, Ill., M. A. Mead, Murray Hill.  
E. Stein (Stein & Ellbogen Co.), Plaza.  
Cincinnati, O., J. L. Davison, 51 Franklin St.  
Decatur, Ill., G. C. Kinsman (Supt. Watch Inspection Wabash R. R.), Marlboro.  
Franklin, Pa., G. W. Feldman (B. J. Feldman's Sons), Park Ave.  
Montreal, Canada, B. C. Silver, Astor H.  
J. C. Silver, Astor House.  
New Britain, Conn., G. H. Dyson, B'way Central.  
H. T. Dyson, B'way Central.  
Philadelphia, Pa., J. A. Schwartz, Astor H.  
J. W. Hutchins, Herald Sq.  
Pittsburgh, Pa., S. Davis, Astor House.  
A. Kingsbacker, Astor House.  
E. R. Hill (Goddard, Hill & Co.), St. Denis.  
S. Cerf, Astor House.  
Providence, R. I., H. Tilden, Manhattan.  
Toronto, Can., E. Scheuer, Astor House.  
M. C. Ellis, Astor House.  
Troy, N. Y., J. W. F. Podmore, Park Ave.  
Washington, D. C., H. L. Galt, Imperial.

## Trans-Atlantic Voyagers.

### TO EUROPE.

Wm. Kleinschmidt, of Kleinschmidt, Howland & Co., New York, sailed Thursday on the *Kaiser Wilhelm der Grosse*.

L. Tannenbaum, of L. Tannenbaum & Co., New York, sailed recently on the *Campania*.

J. Moreels, H. S. Vrieslander and L. Vrieslander, of Vrieslander & Moreels, Antwerp, Belgium, accompanied by their wives, sailed Wednesday on the *Kensington*.

F. A. Jeanne, with Alfred H. Smith & Co., New York, sailed Wednesday on the *New York*.

Abel King, of I. Emrich & Co., New York, sailed for Europe recently on the *Aquitaine*.

About March 1 the Wadsworth Watch Case Co. will remove their factory into the new buildings which they recently purchased at Dayton, Ky., which is near Newport, same State. In their new home the company will have one of the finest equipped factories in their trade, the buildings being the ones formerly occupied by the Cordage Trust, put up at an expense of over half a million dollars. The two buildings are 240x300 feet, one being a one story and the other a two story structure. They are lighted with electric light and are fitted with the latest process of steam heating, which also acts as a cooling apparatus in Summer time. They are equipped throughout with the most up-to-date fire apparatus and other improvements and the power is supplied by two engines of 350 h. p. each.



## Brotherhood of Travelers.

### Interesting Annual Meeting of the Brotherhood of Traveling Jewelers.

The Brotherhood of Traveling Jewelers, that praiseworthy organization of jewelry representatives who are banded together for the purpose of assisting the needy in their profession, met in annual convention, Saturday, for the tenth time, at the Astor house, New York. The meeting was one of the most important in the history of the organization, inasmuch as the members, among other work, adopted a new constitution for the Brotherhood. This constitution was formulated by a committee at the last meeting, who reported at a special meeting last July. The meeting Saturday began at 1.30 o'clock and lasted until 5 o'clock P. M. and was attended by about 30 members. After a reading of the minutes by Secretary Schwartz, president Chas. A. Boynton made the following address:

ADDRESS OF C. A. BOYNTON, PRESIDENT.

#### Brother Travelers:

I congratulate you all on this the tenth annual meeting of our Brotherhood; it is an important one, denoting the passing of a decade since our organization. We have maintained our Brotherhood with full membership since its organization. This fact is remarkable, considering our annual meeting being the only one we hold during the year.

I fear that your President's address will contain less items of interest to you than formerly, as my predecessors have so ably explained in their annual addresses the workings and object of our organization, and the many trials and hardships incident to the life of a traveler, that scarcely anything I could say at this time would be new or interesting.

That the jewelry traveler is not properly estimated financially I think you will all agree. In nearly all other lines of trade travelers are considered very important factors; they call on their customers at regular intervals, finish the season's trade, and return home, while we have a continual season from Jan. 1 to Dec. 24, and I am credibly informed that some firms act as if they considered the days too short. Our employers require us to carry valuable trunks, impose rules some of which are ridiculous as well as ambiguous, and expect us to keep and perform them—also to make credits, collect debts, furnish new ideas, and at all times look pleasant. I presume there are those present who have heard the old excuse of "Presidential year" again repeated as another reason for not increasing salaries.

These are all disagreeable subjects, but I have touched on them as they seem to be proper at our annual meetings, as they affect us most. I am glad that not all of us have to complain about our treatment, but considering the manifold duties required of us as a class we are underpaid.

During the past year you have had but one assessment, which is less than usual. We have had returned to us money we gave a stranded brother; this being one of the few occurrences of this kind, I thought it well to inform you. That some of our brothers whom we have assisted have bettered their condition, should be another cause for gratification. No person, unless in real distress, can understand what aid such as we give means to those who receive it.

It is hardly to be expected that we could pass through a year without some of our members being summoned to that "far and undiscovered country from whose bourne no traveler e'er returns." William Harris and William Morris have both gone on that last trip—they have passed from the house of mortality into one of immortality. William Harris' death was especially sad—his condition for a long time was distressing to his friends. It is seldom that a person dies in a place known as their home without any ties of kinship, as in this case. The Brotherhood, through its officers, took charge of his body, held a funeral service, and sent a member of the Executive Committee to Albany with the remains, where he was met by an escort from Temple Commandery K. T. I here-with incorporate the letter received from the eminent Commander of Temple Commandery:

"ALBANY, N. Y., March 23, 1899.

"Mr. C. A. Boynton, President,

"No. 201 West 121st St., New York, N. Y.,

"My Dear Sir:—It may interest you to know that Sir Knight William Harris was buried from the Masonic Temple, Albany, with Templar honors on Tuesday afternoon, March 21, at 3 o'clock. The bearers were eight in number and went to the cemetery to see that the remains were deposited with proper respect in the receiving vault. Five of the

eight bearers were old friends of Mr. Harris. The service was read by the Prelate and myself, a very respectful body of Knights being present as an escort. There were also present quite a little party of some who were old friends of the deceased, among them several ladies. Altogether, it was a very quiet, dignified and respectful service and I thought his friends in New York would be interested in knowing it. I regretted that the Sir Knight in attendance was compelled to return so soon, and I did not know of it until told by the undertaker the next morning after his departure.

"In regard to the committal of the remains to the ground later. If Commander at that time I will use my best offices to see that it is done decently, and in the rural cemetery as Sir Knight Harris requested. If he cannot be buried in the Masonic lot the Commandery can buy a single grave. I remain,

"Courteously yours,  
" (Signed) JOSEPH D. CRAIG,  
"Commander."

William Morris's death was very sudden, but a representative of the Brotherhood was present at the funeral and placed a token from the Brotherhood on the casket.

I wish to express my sincere thanks to all the members of the Executive Committee for their untiring zeal and energy displayed on all occasions. Their report you will find to be both pleasing and gratifying. Our Secretary and Treasurer's report speaks for itself. Under the head of new business it will be necessary for you to take up the revision of our Constitution and By-Laws, a copy of which was mailed to your address thirty days before this annual meeting, in compliance with our present Constitution and By-Laws. The Committee appointed by my immediate predecessor have carefully considered and prepared the revisions and recommended their adoption.

It is with sincere gratitude that I return the gavel placed in my hands, and I trust and hope I have so conducted the affairs of our Brotherhood as to give offense to none but satisfaction to all.

The address was roundly applauded and was followed by the reports of the various officers and committees. The executive committee's report, the first in order, gave evidence of the general prosperous condition in the jewelry trade in showing that there were fewer cases where assistance was needed among the traveling jewelers than at almost any other time since the organization started. The secretary and treasurer's report showed the organization to be in excellent financial condition. The constitutional committee reported the constitution, which was then taken up item by item and adopted unanimously.

The salient change in this constitution lies in the fact that it increases the membership from 100 to 150. A number of new articles were added, and in all the effect will be to put the organization in better working condition, or better business basis, than ever before. The meeting concluded with the election of officers for the ensuing year, the entire list being elected unanimously.

Charles A. Boynton was re-elected president; W. C. Parks, of Parks Bros. & Rogers, who was formerly chairman of the executive committee, was made vice-president, and H. C. Schwartz, of Larter, Elcox & Co., was re-elected secretary and treasurer. The new constitution provides for an executive committee, all of whose membership shall be re-elected each year. The following are named by the convention for the two year term: C. E. Settle, with O. M. Draper, and A. Rutherford, with H. A. Kirby Co.; for a one year term, D. V. P. Cadmus, with Chas. F. Wood & Co., and F. L. Wood, with Ludwig Nissen & Co. The nominating committee elected are: W. W. Hayden, of Wm. W. Hayden Co.; E. L. Brown, F. J. Foster, with Unger & Ackley, and E. H. Eckfeldt, of Eckfeldt & Ackley.

After the election the usual vote of thanks to the retiring officers and committees was passed and the members then adjourned to meet again next year.

## Death of J. George Bonny.

J. George Bonny, probably the oldest and most prominent retail jeweler of California, died Thursday last of pneumonia, at the home of his sister, Mrs. E. G. Carslake, at Bordentown, N. J.

The deceased was for nearly 40 years connected with the house of Geo. C. Shreve & Co. and their successors, Shreve & Co., leading jewelers of San Francisco, although for the past four years he had not actively participated in the management of the business. Mr. Bonny was born 74 years ago and was one of the first of the eastern merchants to become prominent in the jewelry trade of California. As a young man he emigrated to that State shortly after the gold fever had broken out, and in the '50's formed a partnership with George C. Shreve, who conducted a retail jewelry business in San Francisco. These two gentlemen were the sole owners of the business until 1878 when A. J. Lewis was admitted into the concern. The business was conducted as a partnership until after Mr. Shreve's death, about 12 years ago, when Mr. Bonny and Mr. Lewis organized the present corporation of Shreve & Co. The active members of the corporation were A. J. Lewis, George Shreve, a son of Geo. C. Shreve, and Mr. Foster. Mr. Bonny, from the time of the incorporation, retained a considerable financial interest in the concern, but did not give active attention to its affairs after Mr. Lewis's death, in 1895. In that year George Shreve became the president and Bruce Bonny, a nephew of J. George Bonny, became the secretary. Since that time the deceased spent much of his time in traveling.

While known by reputation to almost the entire trade, the deceased was perhaps better known personally to the customers of his firm, among whom he made many friends. In the early days he had charge of the business and through his excellent ability as a salesman helped to build it up to the position it attained. The deceased was a bachelor and is survived only by his sister, at whose home he died, and a brother, who is the father of Bruce Bonny.

The funeral services were held at Mrs. Carslake's home, in Bordentown, Monday morning at 10.30 o'clock, and among those in attendance were many representatives from prominent jewelry and silver ware firms in the east.

## Report of Emerald Mine in New Hampshire.

[From the Boston Traveller.]

CONCORD, N. H., Dec. 26.—Notwithstanding mining parties have been trying to keep it a profound secret, it has finally leaked out that a rich beryl-emerald diamond field has been found on a mica and garnet tract on the edge of Springfield, N. H., two and a half miles from the Grafton, N. H., depot, on the Concord division of the Boston & Maine.

Geo. F. Kunz, the gem expert and mineralogist, when shown the above, said the stones referred to were probably aquamarine. He doubted whether any emeralds existed in that part of the country, and, as for the "diamond" part of the dispatch, he said it was nonsense.

The Creditors of the J. B. Gotthelf Jewelry Co.

The creditors of J. B. Gotthelf Jewelry Co., Memphis, Tenn., who suspended payment a few days ago, are:

OPEN ACCOUNTS.

Ketcham & McDougall, \$72.25; T. G. Hawkes & Co., \$97.70; Heyman & Kramer, \$356.00; J. W. Tufts, \$261.25; S. Valfer & Co., \$73.94; Meriden Cutlery Co., \$247.00; Engelfried, Braun & Weidmann, \$225.00; Meriden Cut Glass Co., \$75.35; Electric City Box Co., \$69.50; Manning, Bowman Co., \$53.30; Queen City Silver Co., \$75.00; Grant Jewelry Co., \$40.70; F. W. Smith, \$245.53; J. J. Cohn, \$88.25; Palmer & Peckham, \$47.25; R. Blackinton & Co., \$118.18; Watson, Newell Co., \$201.12; Aikin, Lambert & Co., \$25.50; L. Wolfsheim, \$133.37; J. W. Reddall & Co., \$165.95; Spier & Forsheim, \$31.00; A. M. Bachrach, \$92.50; M. Sickles & Sons, \$221.81; Wilcox Silver Plate Co., \$174.36; Holmes & Edwards Silver Co., \$117.27; Adelphi Silver Plate Co., \$111.17; A. Wallach & Co., \$312.38; Simmons Hardware Co., \$97.65; Langfeld Bros. & Co., \$95.25; Rauch & Goldsmith \$143.96; Mabie, Todd & Bard, \$83.04; A. Kohn & Co., \$70.78; H. L. Judd & Co., \$81.75; A. Wallach & Co., \$21.40; Amasa Lyon, \$102.75; Stern Bros. & Co., \$141.63; Hamilton Mfg. Co., \$61.50; Dattelbaum & Friedman, \$282.90; Fred Kaufman, \$487.00; Bernheim, Cohn & Beer, \$67.44; L. Kaufman & Co., \$472.38; Rosenbaum & Adler, \$146.00; A. Rosenthal, \$71.00; E. A. Cowan, \$15.00; H. Cowan, \$568.25; Wm. Kinscherf, \$336.85; Champenois & Co., \$141.75; H. Didisheim & Bro., \$296.90; M. Weil, \$230.88; Mauser Mfg. Co., \$443.25; Woodside Sterling Co., \$273.25; Dennison Mfg. Co., \$106.66; Byron L. Strasburger & Co., \$403.00; J. Strauss & Sons, \$111.50; New England Watch Co., \$165.25; S. B. Champlin Co., \$273.00; Jennings Bros. & Co., \$39.50; Stone Bros., \$23.75; Derby Silver Co., \$335.66; Weinmann Bros., \$79.53; E. & J. Bass, \$140.88; C. P. Goldsmith & Co., \$519.00; Simpson, Hall, Miller & Co., \$362.00; H. H. Curtis Co., \$148.00; Wm. Link, \$236.30; L. Krower, \$156.22; E. A. Cowan, \$139.85; Meriden Britannia Co., \$301.18.

NOTES.

J. Strauss & Sons, \$100.00; Spier & Forsheim, \$414.87; I. W. Friedman, \$986.44; Arnstein Bros. & Co., \$1,001.50; Fred Kaufman, \$281.03; Henry Cowan, \$135.99; Rosenbaum & Adler, \$736.57; Marx & Brod, \$2,296.41; B. H. Davis & Co., \$4,344.05; Zimmern, Rees & Co., \$1,509.06; Ingomar Goldsmith & Co., \$2,029.62; A. Rosenthal, \$506.68; I. Michelson, \$1,910.00; David Marx, \$1,074.04; E. A. Cowan, \$564.66; B. L. Strasburger & Co., \$1,176.99; Bernheim, Cohn & Beer, \$432.52.

Death of Thomas Allan.

MONTREAL, Can., Jan. 2.—The death took place yesterday, from typhoid fever, of Thomas Allan, of Thomas Allan & Co., St. Catherine St. Mr. Allan was born at Dunfermline, Scotland, 60 years ago, and came to Canada in 1849. He was apprenticed in early life to the then well known firm of Savage & Lyman, and shortly after the expiration of his apprenticeship went into business with Peter Wood, the firm being known as Wood & Allan. Later he started the business which he carried on at the time of his death.

Connecticut.

Hon. Charles Parker, Meriden, became 91 years old Jan. 2. Mr. Parker is enjoying excellent health for one of his years.

Eugene H. Rowe, of W. S. & E. T. Rowe, jewelers, New Haven, has been appointed clerk of the Bureau of Compensation at a yearly salary of \$400.

H. J. Rolfe has become a traveling salesman for the Derby Silver Co., Factory B of the International Silver Co. He was formerly with H. Wales Lines Co., Meriden.

John B. Kirby, son of Samuel H. Kirby, New Haven, on Jan. 1 became a partner in the jewelry firm, and the firm name is now S. H. Kirby & Son. The business was started 70 years ago by Brown & Kirby.

The National Self-Winding Clock Co. for the manufacture of a clock invented by Dr. Percy L. Clark, have located in Bristol. Dr. Clark is president of the company and John J. Jennings, secretary and treasurer.

The officials of the E. N. Welch Mfg. Co., Forestville, received plans for their new case shop Jan. 5. They will try to get the work completed by April 1 or sooner if possible. The shop will be 200 feet long, 50 feet wide and three stories high.

Stockholders of the Manhattan Silver Plate Co., Lyons, N. Y., whose plant is in the International Silver Co., will vote Jan. 15 upon the proposition of dissolving the corporation. This is simply a legal formality to convey the assets of the Manhattan Silver Plate Co. to the International Silver Co.

At the annual meeting of the Winchester Optical Co., Winsted, just held, some radical changes were made. M. E. Norton has purchased the shares held by John W. White, Archibald C. Calder and William J. Slavin. The business will be continued at the old stand, and will probably be incorporated in the near future. John D. Perkins will continue as superintendent.

At the annual meeting of the stockholders of Holmes, Booth & Haydens, Waterbury, which will be held Jan. 25, it is proposed to change the name of the corporation as recommended by the directors by prefixing the word "the" and adding the word "company" to the present name, so that the name will be "The Holmes, Booth & Haydens Company." It is also proposed to increase the capital stock of the company from \$400,000 to \$1,000,000.

INDEX TO ADVERTISEMENTS.

Table listing various companies and their page numbers, including Aikin, Lambert & Co., American Watch Case Co., Arnstein Bros. & Co., etc.

We have made a specialty of

FINE FINGER RINGS

for more than half a century.

GEO. O. STREET & SONS,

24 JOHN ST., NEW YORK.

... Established 1837 ...



## Special Notices.

Rates 75c. per insertion for notices not exceeding 3 lines (25 words); additional words 2 cents each. If answers are to be forwarded, postage stamps must be enclosed. Two insertions, 15 per cent off; three insertions, 20 per cent off; four insertions or more, 25 per cent off. Payable strictly in advance.

Display cards on this page will be charged at \$2.00 per inch for first insertion, subject to same discount as above for subsequent insertions.

Under the heading of **SITUATIONS WANTED** on this page advertisements will be inserted for **One Cent a Word**, each insertion, no discount, but no advertisement will be inserted for less than 25 cents. This offer refers to **SITUATIONS WANTED ONLY**. Payable strictly in advance.

In all cases if answers are to be forwarded, 10 cents extra to cover postage must be enclosed.

## Situations Wanted.

**15 YEARS' EXPERIENCE** as watchmaker, optician and salesman; gilt edge references; open for position. Write Box 314, South Manchester, Conn.

**ENGRAVER AND JEWELER** wishes position with first-class house; will send photo and sample of engraving. Address, "Young," care Jewelers' Circular.

**EXPERIENCED TRAVELING SALESMAN** desires position with watch case or jewelry manufacturer; good references. Address, "Traveler," care Jewelers' Circular.

**A YOUNG MAN** wishes position in silver ware or jewelry house as salesman; 5 years' experience; first-class references. Address, "Waltham," care Jewelers' Circular.

**PRACTICAL DESIGNER**, with 15 years' experience in all branches of sterling silver ware, desires position; all references furnished. Address "Sterling," care Jewelers' Circular.

**SUPERINTENDENT AND DESIGNER** with large experience in all branches of sterling silver ware desires position; best of references. Address "Designer," care Jewelers' Circular.

**WANTED**—A silver or gold line of goods to carry in connection with another through New England and Middle States, on commission. Address, "New England," care Jewelers' Circular.

**WANTED, TO REPRESENT** a manufacturer of gold jewelry or silver novelties, in New England and middle States south to Virginia; best of references. Address, W. M., care Jewelers' Circular.

**YOUNG MAN**, 19, living home with parents, desires position where he can advance; good references; has been in jewelry and diamond business 2½ years. Address, Prescott Bldg., Room 43, New York.

**FIRST-CLASS WATCHMAKER** and engraver, age 26, have had 12 years' experience, can take full charge of store if wanted, first-class references can be furnished; none but good houses need answer. Address C. C., care Jewelers' Circular.

**CATALOGUE MAKER AND ADVERTISER** of many years' experience, with knowledge of the jewelry business, desires to connect himself with good house; understands reaching buyers; highest references. Address, "Arthur," care Jewelers' Circular.

**WOULD LIKE** a position as traveling salesman for manufacturing or wholesale jewelers; young man, single, good references and knows the business thoroughly. Address, W. J., care Jewelers' Circular.

**OPTICIAN**, watchmaker and engraver wants a steady position with a good firm; understands the business thoroughly; young man, single, sober and steady; have tools and trial case; state salary in first letter; all references. Address, "Optician," care Jewelers' Circular.

**WANTED**—Situation by watchmaker, engraver and salesman; American, 38 years old, 26 years' experience at bench, five years with present employer; fully competent to take entire charge of store or department; if you want sober and industrious man, write me; personal reasons for desiring change. Address "Blue 19," care Jewelers' Circular.

**SIDE LINE**—An experienced and successful salesman now calling on retail jewelers, department stores, etc., in Michigan and Illinois with a line of leather goods wants to add a side line of small goods such as link buttons, brooches, belt buckles, jeweled combs, beauty pins, novelties in plated silver and set goods, medium and cheap grades; a line that can be carried in small trunk or sample case; have established trade and can furnish highest references. Address with full particulars, F. L. H., 1801 Jackson St., Sioux City, Iowa.

## Help Wanted.

**CUT GLASS SALESMAN** wanted to represent a large factory. Answer, stating full particulars, "Cut Glass," care Jewelers' Circular.

**SALESMAN FOR SOUTH**—Experienced man wanted, no other need apply. Averbek & Averbek, 19 Maiden Lane, New York.

**WANTED**—First-class jewelry repairer, stone setter and engraver; one capable of helping with clock work preferred. C. L. Bryant, Danbury, Conn.

**WANTED**—First-class manufacturing jeweler to go to Colorado; one who can do monogram and letter engraving. Address, "A," care Jewelers' Circular.

**WANTED AT ONCE**, jeweler who can do all kinds of new work, diamond setting and engraving; steady job; state salary. Address, J. Levinski, Waco, Tex.

**WANTED**—Good watch and clock repairer; man who is practical; none but a first-class mechanic need apply; Philadelphia married man preferred. Address, "Phila.," care Jewelers' Circular.

**WANTED**—Two first-class manufacturing jewelers and stone setters; one first-class engraver and jeweler; references required. Geo. Wettstein, manufacturing jeweler, Cedar Rapids, Iowa.

**WANTED, YOUNG MAN**, 18 years of age; must write good hand and figure well, to assist in office and stock of jobbing house. Address, stating experience and salary desired, F. A., care Jewelers' Circular.

**WANTED**—Young man, 20 to 22 years of age, of good address and ability, as salesman in New York City; one acquainted with the jobbing trade preferred. Apply to Larter, Elcox & Co., 21-23 Maiden Lane, New York.

**OPTICIAN** and jewelry jobber; one who understands clock work preferred; must be sober and industrious; permanent position to the right man; best of references required. Address, "Optical," care Jewelers' Circular.

**SALESMAN WANTED** to carry a moderate-priced gold line on commission in connection with another non-conflicting line, through New York State and the west. Address, R. L., care J. Frank Beers, 607 Broad St., Newark, N. J.

**WATCHMAKER** who is engraver, jeweler, salesman, stockkeeper and all-round helper with tools; steady job; send sample of engraving, and photo; state wages wanted and full particulars. Address, "Jeweler," care Jewelers' Circular.

**FIRST-CLASS WATCHMAKER** wanted; one used to handling fine class railroad work, and able to take charge of general management; of good appearance and salesman, with high-class testimonials; wages, \$20. A. Weiner, 2693 Third Ave., New York.

**WANTED**—Experienced salesmen having an acquaintance with the jewelry and stationery trade, to sell fine line of gold pens, pencils, silver novelties, fountain pens, etc., for the middle western States. Address, Edward Todd & Co., 9 E. 16th St., New York city.

**AFTER JAN. 1**—A first-class manufacturing jeweler and stone setter who can make all kinds of diamond mountings, cluster work, and understands enameling and the use of dynamos for gilding and plating, as foreman in a newly equipped shop with six to eight men; highest salary and permanent position to right man; best of references required. Address, G. O., care Jewelers' Circular.

**WANTED**—FIRST-CLASS SALESMEN to sell on commission to retail trade our celebrated 14k. solid gold filled band rings of our own manufacture; these goods are put up in beautiful and expensive pyramid shape show cases; only experienced salesmen that sell other lines; exclusive right of State given; either \$100 indemnity or cash bond required for samples and faithful performance. Address, Arnstine Bros. & Mier, Cleveland, Ohio.

## Business Opportunities.

**WANTED**—A line of gold rings to carry with an established line; territory, west to coast, south to New Orleans; on commission. Address, N., care Jewelers' Circular.

**JEWELRY STOCKS BOUGHT**—Retailers wishing to dispose of surplus or entire stock of diamonds, watches and jewelry can find quick, cash, strictly confidential buyer by addressing S. Marx, 22 Lispenard St., New York City.

## Wanted to Purchase.

**WANTED**—First-class jewelers' safe, double doors, burglar proof; must be a bargain; state size and price, Jacobs Jewelry Co., 41 Washington Ave. So., Minneapolis, Minn.

## To Let.

**TO LET**—Part of office and factory on third and fourth floors of No. 24 John St. Inquire of A. F. Dejonge, 24 John St., New York.

**OFFICE ROOM** to let to nice, quiet firm with us; terms \$25 per month. A. S. Gardner & Co., Room 73, Hays Building, 21 and 23 Maiden Lane.

**FRONT OFFICE**, 18x72 (occupied by the E. Howard Watch and Clock Co. for 14 years); also smaller offices and rooms for light manufacturing; rents low. Knapp Building, 41 and 43 Maiden Lane, New York.

## WANTED—DIAMOND SETTER

and Jeweler Must be a good setter, and able to do hard-soldering and general repairing. First-class wages and permanent position for a good man. Good references required.

HENRY KOHN & SONS,  
890 Main St., Hartford, Conn.

## Wanted Immediately,

experienced and thorough workman who can do difficult jewelry work (diamond setting included). Good engraver and do watch work; must be of neat appearance and capable of waiting on retail trade. To the right man a permanent position and a good salary. Gilt edge reference required; must be sober and strictly honest. Send sample of engraving with application.

Address, H. J. HOMRICH,  
915 Third Ave., Huntington, W. Va.

## TO LET

IN THE

**UPTOWN JEWELRY and SILVERWARE DISTRICT,**

**UNION SQUARE, WEST,**

From Feb. 1, for a term of years, No. 19, (second door above Tiffany's), large store, basement, first and second floors; separately if desired. Janitor on premises. Apply to

**HORACE W. DAY,**  
17 STATE STREET, NEW YORK.  
TELEPHONE, 724 BROAD.

## CASH OFFERS.

If at any time you have offered to you by your customers any jewelry containing diamonds, pearls or other precious stones, and you do not care to buy them yourself, send them to us and we will submit an IMMEDIATE CASH OFFER. Trade and Bank References if desired. Established 1880. Correspondence solicited.

CHARLES S. CROSSMAN & CO.,  
3 Maiden Lane, New York.

THE EMPIRE WESTWARD TAKES ITS WAY

# WESTERN SUPPLEMENT

## THE JEWELERS' CIRCULAR

VOL. XXXIX.

NEW YORK, WEDNESDAY, JANUARY 10, 1900.

No. 24.

### Chicago Notes.

All communications in reference to the Chicago department of *The Jewelers' Circular*, addressed to Stephen Parlin, 1522 Lill Ave. (Telephone, Lake View 397), Chicago, will receive prompt attention.

W. H. Vogell, of Alfred H. Smith & Co., left for New York, Friday, for a visit at the home office.

M. S. Rodenberg, of Rodenberg & Dunn, spent a week here with the trade, coming direct from the factory and New York.

Mr. Mead, of M. A. Mead & Co., has gone to New York to see his daughter off for Egypt, where she will travel and study for some 18 months.

J. H. White, traveler for Department L of the International Silver Co., returned from Wallingford and New York and left Tuesday to cover the territory west of the Mississippi river.

There was quite a hegira of Chicago men to New York on the 5th, including H. W. Allen, of Rich & Allen Co.; Al Sproehle, of Sproehle & Co., and B. Frank Davis, of the Chicago office of Hipp. Didisheim & Bro. All are east on business matters.

Fred H. Allen, who has represented Barstow & Williams in this city for the past year, has severed his connection with that house and will represent Dutee Wilcox & Co. at their Chicago office, taking the vacancy caused by Lou Fay's resignation to take the R. F. Simmons & Co. line.

A. H. Hurd will leave for the central west about the 15th inst. in the interest of the Seth Thomas Clock Co. Mr. Hurd has been outside of this line the past few years, but was formerly with Lapp & Flershem for seven years, and no doubt will meet many of his former friends in his travels.

Jake Sommer, of Sommer & Mills Co., North Attleboro, came in Saturday with good reports of his trip, which so far has covered Pittsburgh, Cincinnati and St. Louis. Mr. Sommer states that he has never known the jobbers to have so many appointments so early in the season, and says all the travelers report good sales.

K. Landau, the wholesale jewelry house at 172 Market St., has moved into more commodious quarters at 155-179 Market St. L. Kabaker, who has had charge of the firm's books for five years past, will this season call on the trade in Illinois. S. Simons, formerly city salesman, will in future visit the trade of the firm in Iowa and Minnesota.

G. M. Huston, jeweler, 203 State St. and his family barely escaped with their lives from their residence, 7659 Normal Ave., early last Wednesday morning, which caught fire from an overheated grate in the basement. The fire was discovered by Mr. Huston, who was aroused from his sleep by smoke and the crackling of burning wood. The fire was extinguished after a damage of \$3,600 had been done to the building and contents.

Regarding the bill introduced into Congress by Congressman Dolliver to repeal the present bankruptcy law, the consensus of opinion among Chicago jewelers seems to be that the law has worked very fairly so far and should remain on the statute books, possibly with some slight amendments. Some say that while there are some objectionable features in the present law they are fully balanced by the good that has resulted to both debtor and creditor. These think that with some amendment suggested by experts the present law should remain. There are other members of the trade who have never favored any bankruptcy law, and would rather see no such law enacted unless it be one where the debtor would have to pay to get clear. Those holding to this opinion think the present law should be repealed as unjust to the creditor.

A handsome frame of photos of members of the Chicago Jewelers' Association was presented to the association at its last meeting by Photographer Gibson and group artists Evans & Schlueter, and occupies a prominent place in the association hall, behind the presiding officer's table. The frame is three feet six inches by five feet. On a gray background the portraits are grouped in plain, gilt, oval frames, cabinet size. In the center is the portrait of President Dodgshun, surrounded by the eight directors. Above this group is an ornamental scroll with the words, "Chicago Jewelers' Association." Below this group is the portrait of Benjamin Allen, vice-president of the association. A double row of portraits is at the sides and a single row at top and bottom, composed of the members other than officers. Beneath each picture is the name of the member. The whole is very artistically done and is a credit to both the photographer and the group artists, as well as a welcome addition to the hall.

### Indianapolis.

F. M. Herron has been re-elected president of the Indianapolis Whist Club.

I. C. Crane has bought a new store house, with dwelling attached, on Virginia Ave.

Charles R. Kluger, Huntingburg, Ind., recently lost his little son, after a severe illness.

The Indianapolis Jewelry Co. have been reorganized, the firm now being Grouse & Kiser, with new quarters on the fifth floor of the Stevenson building.

H. L. Rost, Columbus, Ind.; E. A. Wiley, Mooresville Ind.; J. E. Ward, Worthington, Ind.; B. Maier, Edinburg, Ind.; W. H. Bacon, Spencer, Ind.; Geo. A. Fletcher, Fairmount, Ind., were in the city last week.

One of the local wholesale houses recently had returned to them a lot of silver hearts stamped with a small cottage and the words, "Home, Sweet Home." The customer out in Illinois gave as his reason for returning them, "that there were not enough *Sweet* homes in his town to make the hearts sell."

Fred Newhart, jeweler, who did a retail business at North Indianapolis, died aboard a Big Four train while nearing Mattoon, Ill., on Jan. 3. He had started for Arizona, hoping to prolong his life. He had been suffering with consumption for some time. His remains were brought to this city at once. He leaves a young wife.

### Detroit.

Police Commissioner M. M. Stanton has purchased a hall clock from Noack & Gorenflo for \$1,000.

The story printed that Henry Caspary was in Europe buying goods for a new jewelry store to be located in the Michell block, corner of State St. and Woodward Ave., is untrue. Mr. Caspary has not fallen heir to a fortune and is at present running a jewelry store on upper Woodward Ave.

### Cleveland.

S. B. Robinson has removed from 96 Superior St. to 224 Superior St.

The Cleveland police received instructions from Cincinnati Saturday night to hold certain boxes shipped to this city by Charles and Laura Balloe, the couple supposed to be from Cleveland who were arrested in that city and who had a large amount of silver ware in their possession which is believed to have been stolen. These boxes are thought to contain other stolen property.

# The S.O. Bigney & Co.'s New Jewelry Plant.

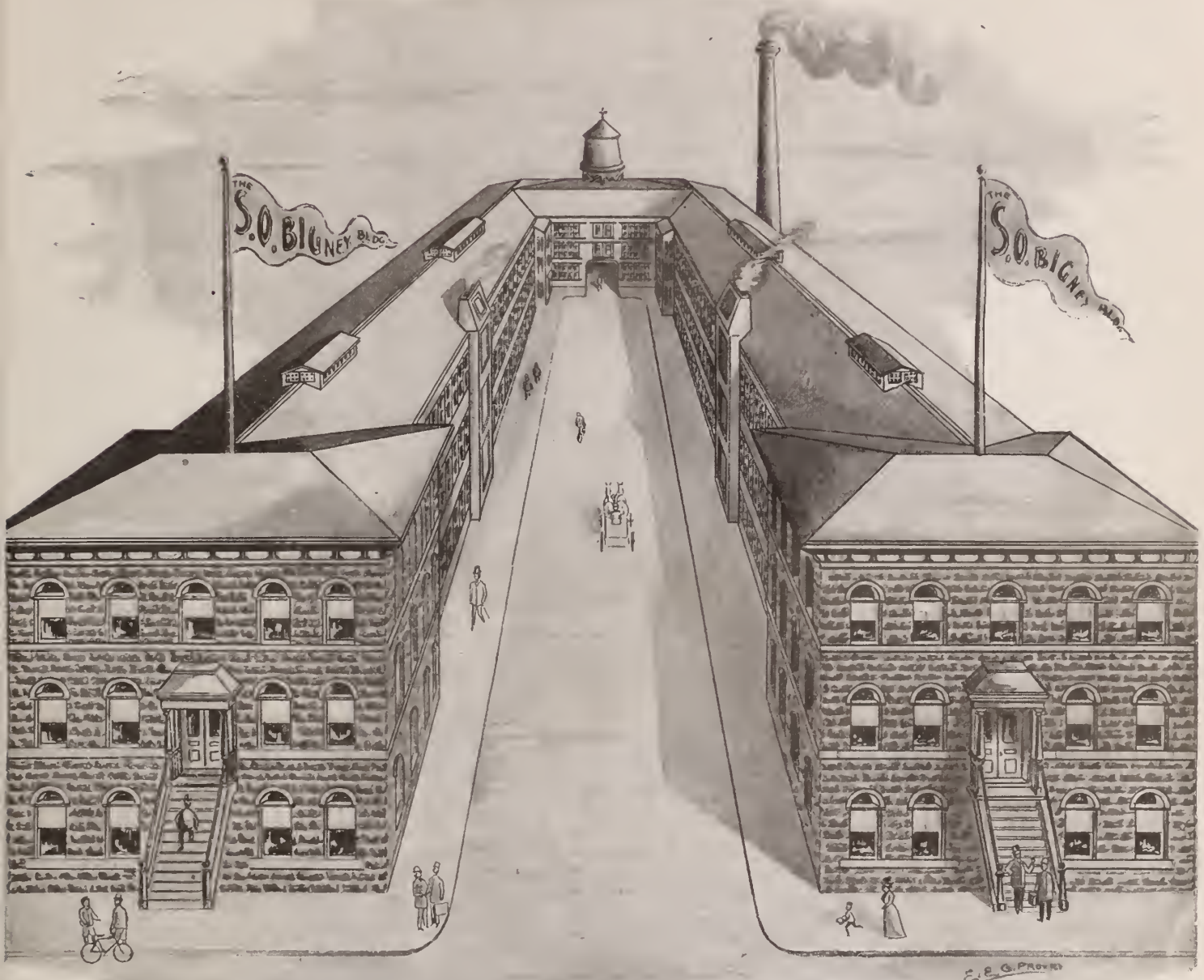

## TO THE JOBBING TRADE OF THE COUNTRY.

ATTLEBORO, MASS., Jan., 1900.

*Gentlemen:*—We take great pleasure in announcing that we are now located in our new plant at Attleboro, the largest and best equipped chain plant in the United States. We take this opportunity to thank the trade for their liberal patronage during the year 1899, which has had much to do in making our house one of the most successful in the jewelry industry. We shall ever strive to please and accommodate our customers in every way. "Promptness" will be our motto from this time forward, and we shall endeavor to ship all duplicate orders within twenty-four and not to exceed thirty-six hours after they reach our factory. Our large space and modern equipment will enable us to accomplish this. We have just one word to say to the retail trade: "Remember that no chain in the world stands higher and gives better satisfaction than our make, and that they are exactly as we represent them. We have three grades, ten, fifteen and twenty year, and every purchaser will get value received. Ask your jobber for these goods, for your stock will not be complete without them."



**S. O. BIGNEY & CO., Attleboro, Mass.**

**St. Louis.**

Octave Alpiser, formerly with Mermod & Jaccard Jewelry Co., is now with S. Ruby, 518 Franklin Ave.

Louis E. Fay has notified the trade here that in future he will be the western representative of R. F. Simmons & Co., Attleboro.

A. Kurtzborn & Son will open a first class jewelry store on Jan. 10, in the new Carleton building. The exact location is 308 N. 6th St.

Wm. Weidlich, representative here of Hamilton Watch Co. and New England Watch Co., is back at his office, after a siege of typhoid fever.

Out-of-town jewelers here last week were few in number. Among them were: Fred. Simon, Collinsville, Ill.; C. E. Randle, Litchfield, Ill.; E. J. Wick, Breese, Ill.

L. Bauman Jewelry Co., this city, have filed suit in the district court at Salt Lake City, Utah, against S. W. Goldwater, jeweler, to recover the sum of \$948.33, with interest, for goods alleged to have been delivered to the defendant in 1896.

John Sluggett has accepted a position with J. W. Cary & Co. Mr. Sluggett has been identified with the material business for the past 25 years, being latterly with S. A. Rider Jewelry Co., previous to that being for 18 years with L. Bauman Jewelry Co.

Bauman-Massa Jewelry Co. gave a supper at Faust's on Saturday evening, Dec. 30, to their employes, in honor of the immense business done during 1899, and to

suitably wind up the year. Among those present were: Edwin Massa, Mr. and Mrs. Sam H. Bauman, Mr. and Mrs. Max Bauman, Mr. and Mrs. Julius Wendel, Jos. McKenna, Wm. H. Felchner, J. Auer and Miss Rose Gregor.

Charles H. Schoen, for 14 years in the local office of the Holmes & Edwards Silver Co. and Barbour Silver Co. and local representative for the past six years of these two firms, has resigned. He will be henceforth in business for himself at the same location, 312 to 319 Holland building, and he will make a specialty of the hollow ware of the Barbour Silver Co. and the flat ware of the Holmes & Edwards Silver Co.

**Columbus, O.**

J. B. White is now closing out the remainder of his jewelry stock to make room for his optical goods, which he is anxious to get into place. When this is completed, Columbus will have two large optical establishments, both doing a retail and wholesale business.

H. J. Heimberger has made some important improvements in his store within the last few months and will in a short time add still others. He has put in a handsome, new 12-foot cherry wall case and three 10-foot counter cases of the same material. In a short time he expects to have another wall case, a mate to the one he has already put in, and a large storage safe.

Reports received here from the smaller

towns of the State indicate that the jewelers have never enjoyed a better holiday trade than they did this year. They say that the business went so far beyond their expectations that they were actually surprised themselves. There will be few clearing sales in this line of goods this season, as most of the holiday goods have gone out and, best of all, have been paid for.

Charles L. Moore, formerly a prominent jeweler of Zanesville but of late a resident of Norwalk, died at his home there Wednesday night. He was a veteran of the Civil War and his pension had lately been increased from \$10 to \$12 per month with \$500 back pay. This comes as a boon to the family, as Moore had been unfortunate and was almost in destitute circumstances. He also had \$5,000 insurance in the National Union.

Two men were arrested at Findlay some days ago on the charge of practicing a swindling game. They gave their names as I. Avery and A. R. Maple. Their plan was to visit towns near by and drop letters containing pawn tickets purporting to be from a woman to her husband and requesting him to send \$10 to the Central Loan & Brokerage Co., of Findlay, to redeem the ring. They expected the letters to be picked up, and, as they were open, the victims were expected to send in the money for the ring. Some of them did and got a cheap metal band for their trouble and money. The men had a kit of burglars' tools in a valise at their room.

1850

**"BELL-POST" BUTTONS**

1900

**WILL NOT BEND OR BREAK.**

**CONSTRUCTION  
PROTECTED  
BY PATENT  
JUST ISSUED.**

**A SAVING  
IN LABOR OF  
50%.**

**PRICES  
REDUCED TO  
CORRESPOND.**



**A NEW LINE  
FOR  
A NEW YEAR.**

**EVERY PAIR  
GUARANTEED.**

**OUR  
GUARANTEE IS  
BASED ON  
50 YEARS OF  
SUCCESS.**

**100 NEW STYLES—SOLID GOLD—NOW READY.****JOHN T. MAURAN MFG. CO.,**

New York Office:

Makers of Gold Jewelry.

3 MAIDEN LANE.

Factory: PROVIDENCE, R. I.

**Cincinnati.**

Joseph Mehmert is taking stock and clearing up for the Spring trade.

B. S. Newman, of Frohman & Co., left for the east Saturday accompanied by his wife. They will register at the Imperial hotel.

Joseph Fahys & Co. will open an office in Chicago this year and Charles Becker will be located at that point. Joseph Becker, who has been the firm's western representative for years, will still have his headquarters at Cincinnati.

The Cincinnati creditors stand very little show of getting anything out of the W. H. Bradshaw failure at Wooster, O., since other creditors from other cities have brought suit and refused to settle on the terms reported in THE CIRCULAR last week. Bradshaw will probably go into bankruptcy this week.

S. B. Duncan, the Arcade jeweler who was robbed a few weeks ago, has offered a reward of \$500 for the return of the paper of single stones, 2½ crown jewel Brazilian diamond, or \$800 for the watches, 13 in all, and the seven diamond rings stolen from his safe Dec. 10. The goods may be returned through his attorney and no questions will be asked. Mr. Duncan has closed his store.

M. C. Motch, a leading jeweler of Covington, Ky., and perhaps the wealthiest jeweler in that State, fell dead at his home on New Year's day. He leaves a wife and two sons. Last Summer Mr. Motch was urged to add \$15,000 insurance to his estate. After the application was written and he had passed examination, he changed his mind and refused to take the policy.

The Bell Watch Case Co. factory buildings at Mansfield are being rapidly pushed forward toward completion and the west wings will be ready for occupancy by next month. The machinery is being constructed to be put in place by the last of this month. The general offices will not be moved up until some time in the Summer. Mr. Bell has been in Mansfield and will go on to New York and take passage for Cuba this week.

**Pacific Northwest.**

**TRADE OUTLOOK.**

According to reports of business men the year just passed has been a good trading year. The jewelers especially are well pleased with results. The holiday trade was very much better than in 1898. Indications point to a far greater increase of general prosperity for the year of 1900, and the jewelers of the northwest fully expect to get a fair share of it. Expansion is the watchword of the entire northwest.

H. Hewitt has located at La Grande, Ore., with a stock of jewelry.

The G. Heitkemper Co., Portland, have inaugurated a clearance sale for one month.

Senator C. F. Easton has disposed of his jewelry business at Wallace, Idaho, to Charles Gibbs.

G. Heitkemper and A. Feldenheimer, Portland, Ore., were last week swindled by Dr. A. Brown, who purchased jewelry and gave in payment bogus checks. Mr. Brown has left for parts unknown and is supposed to now be in Chicago. Mr. Feldenheimer lost about \$190, while Mr. Heitkemper sold jewelry to the amount of \$65 to the swindler.

**San Francisco.**

Joseph Schwalbe, of Jos. Schwalbe & Co., is preparing to start for the east.

The California Association of Opticians will meet at San Jose, Cal., on Jan. 15.

Joseph Kessler, of the J. & F. Kessler Onyx Works, this city, died a few days ago.

Albert P. Rothkopf, diamond setter, has been sued by his wife for divorce on the ground of cruelty.

George Brown, jeweler of this city, recently returned from the Cape Nome gold fields. He is reported to have been very fortunate and is said to be now a rich man.

It appears that F. T. Keeler, jeweler, whose arrival from Skaguay, Alaska, was noted a couple of weeks ago, is here in the interests of a large number of mining claims.

J. M. Palmer, Gilroy, Cal.; M. Ingalsbe, of Nordino & Ingalsbe, Salinas, Cal.; A. B. Wilson, Martinez, Cal., and A. T. Conrad, Fresno, Cal., were trade visitors in San Francisco Christmas week.

Haskell & Muegge have been taking stock and closing up the business of the year. The last few months have been busy ones and they expect a renewal of the activity early in the year. A. I. Hall & Son are in the midst of stocktaking.

**Pacific Coast Notes.**

R. B. Cowan has opened a jewelry store at Monrovia, Cal.

C. H. Tully, Middletown, Cal., has discontinued business there.

J. W. Sever, Colfax, Wash., has given a chattel mortgage on his stock for \$600.

G. Michaelian, Fresno, Cal., has given a mortgage on his realty to secure a note of \$500.

B. F. Cassiday has closed his jewelry business at Suisun, Cal., and will go to San Francisco shortly.

B. J. Morey will erect a new jewelry store at Corning, Cal. The structure will be of brick, with an iron and plate glass front.

W. J. Martin, jeweler, of Chicago, is looking for a location in San Mateo county, Cal., to build a stone polishing establishment.

L. Bome, the alleged diamond thief, was held over in court in Joliet, Ill., to await the action of the Grand Jury in bonds of \$500. Mr. Larson, a clerk in G. E. Feagans's store, testified that the prisoner adopted sleight of hand maneuvers to take a \$130 ring.

**Items from Near and Far.**

Bray & Turner, Bedford, Ia., have given a bill of sale.

Will Coppernoll, Warren, Ill., has failed and the business has been sold.

H. W. Wyman, Colorado Springs, Col., has been sued for divorce by his wife, and has transferred his stock.

A fire occurred a few days ago in the building in Kankakee, Ill., in which E. C. Pike's jewelry store is located. The damage was slight.

George J. Wilson, until recently a clerk in Robinson & Son's jewelry store, Springfield, Mass., has gone to Canada, where he will join the British army for service in South Africa.

Albert S. Jeffries, jeweler, 22 Perry St., Trenton, N. J., was arrested Jan. 4 on complaint of Mrs. A. L. Stats on the charge of larceny as bailee. He was held in \$100 bail for court. The complainant charges that she took a watch to Jeffries's shop to be repaired, and that he pawned it for \$10, and that she has never been able to get it back. Mr. Jeffries admits that he pawned the watch.

One who acts as agent for a nonresident firm, and takes orders for future delivery, the packages being made up by the firm and shipped to him for delivery and collection, is not an itinerant merchant or transient vendor, within an ordinance requiring such to take out a license.

**ABSOLUTELY THE BEST.**



Manufactured by F. H. NOBLE & CO.,

103 State St., Chicago.

Sold by all Jobbers.

**Georgian STERLING SILVER.**

In Complete Table Service—



COFFEE SPOON.

French Gray Finish.

**TOWLE MANUFACTURING CO.,**

CHICAGO.

NEWBURYPORT, MASS.



## Canada Notes.

### TRADE CONDITIONS.

Business continues unusually active for the season after the holidays. The demand for high grade watches is especially good, 21-jeweled goods being much in requisition, mainly from railway men, but the supply continues short. Reports from all over the country indicate that an exceptionally profitable trade was done during the holidays.

S. Midd has opened a jewelry store at Pierson, Man.

E. G. Amy, Cobden, Ont., is offering to compromise at 20 cents on the dollar.

C. E. Walford, jeweler, Ymir, B. C., has given a chattel mortgage for \$450 to G. B. Matthew.

W. M. Sprout, jeweler, Greenwood, B. C., has been succeeded by Sprout & McPherson.

J. J. Ullman, jeweler, Kaslo, B. C., has given an absolute bill of sale to S. Newschwander. Amount, \$1,330.

James A. Goodsall, jeweler, and Mary G. Goodsall, Belleville, Ont., have given a chattel mortgage to W. N. Snider for \$299.

C. S. Ellis and wife will shortly pay a visit to Montreal to look over the branch establishment of P. W. Ellis & Co., in that city.

The branch at Sturgeon Falls, of the establishment of E. G. Amy, Cobden, who recently failed, was recently closed up after a brief existence.

M. C. Ellis, of P. W. Ellis & Co., Toronto, has been elected vice-president of the Toronto Commercial Travelers' Association by acclamation.

Out-of-town buyers calling on the Toronto trade last week included: F. T. Rixon, Meaford; A. Wilson Havelock, and J. F. Van Dusen, Flesherton.

Frank Lefebvre, formerly with M. Cochenthaler, jeweler, Montreal, and more recently with H. & A. Saunders, Toronto, has left to engage in business in New York.

R. B. Way, watchmaker, Prince Albert, N. W. T., has given a renewal chattel mortgage to G. H. McGuire for \$369, and a new chattel mortgage to the same person for \$764.

R. Y. Ellis, of P. W. Ellis & Co., Toronto, has been nominated by the Canadian Manufacturers' Association as one of their representatives on the Technical School Board.

A. McKenzie, formerly with the American Waltham Watch Co., Montreal, and more recently with Alfred Eaves, has joined the second contingent of volunteers for South Africa.

Fire broke out in the jewelry store of Louis Lemaitre, St. Cunegonde, near Montreal, one evening last week and destroyed about \$500 worth of stock and fixtures before it was subdued.

E. Jacot has been appointed watch inspector at Quebec city for the Canadian Pacific Railway, vice A. C. Routier resigned. A. J. Bergeron has been appointed inspector for the company at Three Rivers, P. Q.

Lieut.-Col. Labelle gave to each of the 21 men of the 65th Regiment of Montreal who enlisted in the first contingent of Canadian volunteers for the war in South Africa, a wrist watch, and, in addition, committed to Capt. Peltier 25 serviceable gunmetal watches, to be given to deserving men of the company.

A. A. Abbott, manager of Smith, Patterson & Co. in Canada, will leave about the 15th inst. for the headquarters, at Boston, to choose samples for the coming Spring trade. He will be accompanied by T. A. Brady, the firm's representative in Ontario, and F. A. Mansfield, representing the firm in the Lower Provinces.

Roden Bros., sterling silver manufacturers, Toronto, have moved into their new factory on King St., W., which has a capacity for the employment of 500 men, though their present staff is not nearly so large. This is a wise provision for future requirements, in view of their experience, as this is the third move they have been obliged to make since the firm were established three years ago, owing to the phenomenal growth of their business. The Goldsmiths Stock Co. are the sole selling agents of the firm.

Mrs. Alice Bensette, mother of C. V. Bencette, jeweler, Windsor, Ont., aged 70 years, was burned to death on the afternoon of Dec. 31 at her home, about three miles from Windsor. She was frying pork for dinner, when the meat caught fire and the flames ignited her dress. Her little grandchild gave the alarm and her son Paul rushed in and found his mother in the death agonies, nearly all her clothes burned off. He extinguished the flames, being himself badly burned, but his help came too late to save her life. Mrs. Bensette was a widow and an old resident of the locality.

## Pittsburgh.

### TRADE CONDITIONS.

The holidays have come and gone and the season of 1899 will long be remembered by the jewelry trade in this city. The financial result has been more than gratifying, and already dealers are forecasting the outlook for 1900 as being of a decidedly golden hue. Fifty and 75 per cent over last year's sales are the usual averages given as the rates of increase. Several wholesalers have said that the amount of cash sales has been extraordinary.

Heeren Bros. & Co. have entered judgment in Common Pleas Court No. 2 against John Fink for \$433.

Joseph A. Link, the Allegheny jeweler whose recent troubles have been exploited in the courts and papers, has given a mortgage to Charles F. Kirschler for \$13,535.

Out-of-town visitors in the city last week were: Carl H. Leighner, Butler, Pa.; A. V. Johnston, Evans City, Pa.; F. N. Marshall, Derry, Pa.; P. C. Yester, McKeesport, Pa.; George Eckert, Jeannette, Pa.; C. C. Marsh, Sistersville, W. Va.; Bert McFarland, Burgettstown, Pa.

The marriage of Miss Mary Barrett, daughter of George B. Barrett, to Clarence Byrnes occurred at the Park Place Hotel, Sewickley, on Saturday, Jan. 6. Mr. and Mrs. Byrnes left immediately on their wedding trip to the Mediterranean. Miss Barrett was a popular girl in the younger set, and Mr. Byrnes is a successful attorney of this city.

B. E. Arons, 315 Fifth Ave., is the latest victim of jewelry robbers. Between 5 and 6 o'clock on Wednesday morning, Jan. 3, an unknown person shattered a plate glass window by hurling a brick through it, and getting away with several hundred dollars' worth, probably \$600, of gold watches, rings, etc. The opening made by the brick was circular, about six inches in diameter. No clue to the perpetrator of the deed has as yet been obtained, though the Pittsburgh sleuths are working actively.

## Syracuse.

E. C. Meachum, for several years with H. J. Howe as watchmaker, left Dec. 26 for Rochester, where he assumed charge of the watch and jewelry department in Sibley, Lindsay & Curr's department store.

Hitchcock & Morse have enlarged their establishment, greatly improved its appearance, increased their facilities for transacting business, and placed in charge of their material and tool department G. A. Gross, for many years with Lapp & Flershem, Chicago, in a similar capacity.

## TO THE TRADE:

NEW YORK, January 1st, 1900.

I desire to inform the Trade that Mr. E. M. Sachs has this day been admitted as partner in my business. The firm name will be

## LOUIS WOLFSHEIM & CO.,

48 and 50 MAIDEN LANE.

Thanking you for past favors, and wishing you a prosperous New Year, I remain, Yours respectfully,

LOUIS WOLFSHEIM.

**Did You Read** our offer in the last issue of THE CIRCULAR of **\$100.00 in Gold** as a Prize for the best sample of engraving done on our engraving machine?

**The Eaton & Glover Company,**

87, NASSAU STREET,

NEW YORK.



## News Gleanings.

L. A. Hyde, Burwell, Neb., has gone out of business.

Geo. D. Van Horn has opened a repair shop in Paris, Tenn.

R. K. Hohmann, Clifton, Tex., has made a deed of assignment.

J. F. Chapman has succeeded Chapman & Epps, Gorman, Tex.

M. H. Mathersen, Charlotte, N. C., is closing out his business.

E. D. Taylor, Pearl City, Ill., has removed his stock to his residence.

A. Bradley, Helena, Mont., has given a chattel mortgage amounting to \$1,795.

W. C. Vivian opened his jewelry business in his new location in Crosswell, Mich., Jan. 1.

On account of poor health George F. Mills, Woodstock, Ill., will retire from business.

In a fire in Glens Falls, N. Y., a few days ago, the jewelry store of Paul Reuss was affected.

G. W. Lewis, Carbondale, Kan., is preparing to move from that city to some new location.

The stock of stationery, jewelry and notions of St. Clair Joseph, Omaha, Neb., has been attached.

The jewelry business of H. E. Knowles, Denison, Tex., is reported to have been attached for \$4,000.

Fred Scott, Carthage, Mo., has just paid off a trust deed amounting to \$400, and gives a new one for \$1,200.

Baron Bros. have bought out the stock of C. W. L. Trottnow, Le Mars, Ia., and will consolidate it with their own.

The business of F. P. D'Arcy, 100 Main St., Zanesville, O., has been closed and the stock removed to Kalamazoo, Mich.

W. O. Lenhart has succeeded to the entire jewelry and drug business of Cooksey, Tonney & Lenhart, La Harpe, Kan.

David H. Porterfield, Holyoke, Mass., is offering creditors 30 cents on the dollar, 10 cents in 10 days, 10 in 30 days and 10 in 60 days.

T. H. Hollister, Freeport, Ill., has taken a partner in the person of Leslie Fargher, who has been in his employ for the past six years.

In a fire in Bowling Green, Ky., at 2 o'clock A. M. Dec. 30, J. W. Campbell, jeweler, lost all his stock except the diamonds in his safe.

M. Schwab, Sr., optician, Savannah, Ga., will have headquarters at D. A. Cooke & Son's store, Jacksonville, Fla., during the winter.

A notice in the local papers announced that the Queen Jewelry Store, 305 Washington St., Cape May, N. J., would change hands Jan. 1.

R. P. Cullen, New Albany, Ind., has applied for the jewelry and novelty concession at the Pan-American Exposition, Buffalo, N. Y.

A chattel mortgage for \$200 to J. L. Schwartz on the jeweler's tools of J. H. Miles, Salt Lake City, Utah, was filed for record last week.

James M. Casperson has given a bill of sale on a half interest in his jewelry business in Thompson, Ia., for \$440, and is reported to have been attached for \$181.

J. O. Munter, for the past 14 years

watchmaker for Eberhardt & Goodholm, Lindsborg, Kan., has decided to open up in business for himself at that point.

The friends of Jeweler Nitche, who left Hazelton, Pa., two years ago and went to the Klondike, have not heard from him for a long time, and the belief is current that he is dead.

A fire originated on the night of Jan. 1 from a defective flue at 238 E. Montgomery Ave., Chattanooga, Tenn., in which J. F. Bennett & Co., jewelers, have quarters. The fire was soon extinguished.

D. Urwitz, Wilkes-Barre, Pa., has suspended payment. His liabilities are about \$30,000. He says his assets are between \$16,000 and \$17,000, but creditors think they would not bring more than \$4,000 to \$5,000.

Capt. Thomas Maher left Louisville, Ky., last week for Buffalo, N. Y., to secure Burke Marshall, a negro taken in custody there. He is wanted in Louisville for robbing F. Mettler's jewelry store several months ago.

On the morning of Jan. 2 a large water pipe burst over the store room of C. W. Flinn & Co., 1126 Eleventh Ave., Altoona, Pa., and water came down through the ceiling in large quantities. The goods were hastily removed.

The Greenleaf & Crosby Co., Jacksonville, Fla., will open their branch store at the Inn, Palm Beach, Fla., in a few days. James F. Lane and H. Crosby have gone from Jacksonville to Palm Beach to take charge of the business.

The Somerville (Tenn.) *Journal* of Dec. 15, in publishing illustrations and sketches of prominent citizens of that town, published a fine half tone cut of Fred. Goosman, jeweler, Somerville, and a fine half tone cut of the interior of Mr. Goosman's store.

Adolph Kahn, formerly engaged in the jewelry business in Washington, D. C., has filed a petition in voluntary bankruptcy. His indebtedness schedules \$2,024.65, against which there are no assets. The petitioner assigned to James H. Clarke, in November, 1894, for the benefit of creditors.

The Waltham Watch Tool Co., Springfield, Mass., will move into their new factory on Wilbraham Ave. in about two weeks, and will then give up their present building. The building has been refitted for the company, and the Waltham company will purchase the building when they move into it. The price to be paid is understood to be in the neighborhood of \$25,000. In their new quarters the company will have about four times the floor space that they now have and new machinery is being put into the building.

F. L. True, of True Brothers, Springfield, Mass., is seriously ill with heart disease, the illness affecting one of his eyes so that it is feared it will become useless. Mr. True was taken sick on Christmas day and previous to that it had not been known that his heart was unsound. As soon as possible physicians will perform an operation upon the eye in an attempt to save the sight. Mr. True went to Springfield from Saco, Me., about a year ago, and since that time has conducted one of the best known and largest jewelry establishments in that city.

## "Georgian"—A Work of Art.

A NEW era in the production of advertising brochures and pamphlets dawned some time ago and many beautiful specimens have been received during the past year by THE CIRCULAR from various firms. These have been noted in our columns and praised variously for their artistic conception, perfect printing, valuable contents and other features; but of all recently issued, no other has been more deserving of commendation for all these qualities, and others beside, than the beautiful volume issued by the Towle Mfg. Co., silversmiths, Newburyport, Mass., to put before the public their "Georgian" pattern in sterling silver flat ware. This book, which is entitled simply "Georgian" and is the second series of the Colonial style issued by the concern, is one of the most interesting and thoroughly artistically gotten-up volumes ever sent to the trade. Over 50 out of the 70 pages that it contains are devoted to matters of historical interest and to places in the old American colonies and in the United States that have become historical landmarks of the Georgian period of our history. The book is printed in the style of publications of the Georgian period, with illuminated pages and a magnificently colored title page in purple, blue, black and gold. An idea of the purpose of this book may be obtained from the title page, which is as follows:

"GEORGIAN—A pattern of spoons, forks and other pieces of table flat ware is partly shown in this book in which is also given an account of the chief events of the War of the Revolution and the acts of oppression which preceded and provoked it; and to which are added sundry pictures of places and things identified with this momentous conflict and in some cases exemplifying the colonial, or most properly called Georgian style of architecture from which the design of this pattern is derived; which style was first produced in England in the 18th Century, and was the result of the adaptation of classical elements to new conditions of application, and all of which is appurtenant to the name and times of—." Here follow, as if it were a proclamation, the signature of George R. and an illustration of the great seal of the King.

Not only are the style and get-up of the book Georgian in every particular, but even the press work and illustrations are similar to those used at that period. By the jeweler who is a student of history or who is interested in the history of this country, this book will be most heartily welcomed, as it will make a fine addition to his library; while as a business auxiliary it will be equally valuable for the pages at the end, giving full illustrations of the many pieces in flat ware made in this pattern. The book opens with a fac-simile of the proclamation by King George III. "for suppressing the rebellion and sedition" in the colonies, as the American Revolution was then termed. Then follow illustrations and descriptions of such places as Governor Wentworth's house in New Hampshire, with interior details, the Hancock house at Boston, the famous Faneuil Hall of Boston, the old South Church and the State House at Boston, thence going down to the historical places in Philadelphia, Washington's headquarters at various places, the Liberty Bell, Washington's home at Mt. Vernon, and carrying the reader right through all the principal historical spots of the Revolution.

**WATCH CASE GUARANTEES.**

THE RETAIL JEWELERS SPEAK OUT AND GIVE THEIR IDEAS ON AN IMPORTANT MATTER BEARING UPON THEIR TRADE.

[This series of letters began in issue of Nov. 15.]

It was upon the request of several responsible jewelers that THE CIRCULAR entered upon the undertaking of obtaining a consensus of opinion from the retail trade regarding the guaranteeing of gold filled watch cases, and sent to a large number of jewelers, indiscriminately, a letter of which the following is a copy:

NEW YORK, Sept. 8, 1899.

WE ARE SENDING THIS LETTER TO THE RETAIL TRADE WITH THE OBJECT OF GETTING THEIR VIEWS ON AN IMPORTANT SUBJECT, NAMELY: THE GUARANTEEING OF FILLED WATCH CASES. FROM THE RESPONSES RECEIVED MAY BE EVOLVED SOME VALUABLE SUGGESTIONS.

OF THE FOLLOWING FORMS OF GUARANTEE, WHICH DO YOU CONSIDER MOST JUST, AND WHAT ARE YOUR ARGUMENTS ON THE SUBJECT?

1. SHOULD THE MANUFACTURER GIVE A NEW CASE OF THE SAME GUARANTEE IN EXCHANGE FOR THE OLD CASE THAT HAS NOT LIVED UP TO ITS GUARANTEE?

2. SHOULD THE MANUFACTURER EXCHANGE THE CASE THAT HAS NOT LIVED UP TO ITS GUARANTEE WITH ONE OF LOWER GUARANTEE? THAT IS, IF A 20-YEAR CASE HAS BECOME DEFECTIVE AT THE END OF 10 YEARS, SHOULD IT BE REPLACED WITH A 10-YEAR CASE?

3. SHOULD THE MANUFACTURER REPAIR THE CASE AND PUT IT IN CONDITION TO OUTLIVE THE UNEXPIRED TERM, IF THE CASE SHOWS THE BASE

METAL BEFORE THE LIFE OF THE GUARANTEE HAS EXPIRED?

4. SHOULD HE GIVE A NEW CASE AND CHARGE FOR THE LENGTH OF TIME THE CASE THAT DID NOT LIVE UP TO ITS GUARANTEE HAS BEEN WORN; IN OTHER WORDS, REBATE FOR THE UNEXPIRED TERM OF GUARANTEE?

YOURS VERY TRULY,  
THE JEWELERS' CIRCULAR PUB. CO.

All those jewelers who did not receive this letter are cordially invited to send their views upon this subject, replying to the questions seriatim or collectively. Their replies will receive the same measure of consideration as those received direct from the letters themselves. The more views on this subject expressed by the trade at large the more convincing will be the conclusions reached.

[Ninth series of replies.]

NELSON, Neb., Dec. 29, 1899.

Editor of THE JEWELERS' CIRCULAR:

Being interested in the watch case guarantee discussion, will give you my views:

No. 1. Yes.

No. 2. No. One reason is that 10-year cases have not the finish, neither are they as well made as 20-year cases, and the pride of the majority of customers would prevent them from carrying anything that is not supposed to be first class. Besides, they are entitled to the grade of case paid for in the first place.

No. 3. In some instances I would say yes; that is where the base metal only shows through slightly, as very often in pendants. I think if manufacturer can repair same as good as new this would be not more than just. But where the

lids and centers are worn, I think a new case should be given.

No. 4. No. Very respectfully,  
D. L. DAVIES

BLOOMINGTON, Ill., Sept. 20, 1899.

Editor of THE JEWELERS' CIRCULAR:

In reply to yours of recent date, I wish to say that in my judgment the manufacturer should replace a case with a new case of the same quality, except when case lives at least 75 per cent of guarantee. If a case wears 75 per cent or better, it should be considered satisfactory to have the manufacturer repair it. We should not forget the fact that some people are much harder on cases than the majority.

Yours, etc., A. E. ELBE.

DIXON, Ill., Sept. 20, 1899.

Editor of THE JEWELERS' CIRCULAR:

Your letter of Sept. 8 to hand on the guaranteeing of filled watch cases. I think that so long as a case is sold with the understanding that it shall be replaced with a new one like it if it does not live up to its guarantee, so long should the manufacturer replace it with a new case without charge. But the manufacturer can in my estimation change his mind at any time as to guaranteeing cases in the future and have an understanding with retailer and consumer, but he cannot get rid of his previous obligations, and they should be lived up to without faltering.

Yours truly, G. O. WENDEL.

LORAIN, O., Sept. 21, 1899.

Editor of THE JEWELERS' CIRCULAR:

In reply to your circular letter of Sept. 8, will say that I think the 1st or 3d form you print is the proper way to make good the guarantee.

If the manufacturer gives a 10-year case in exchange, as per 2d form, he is furnishing not only an inferior case in quality, but in appearance. If he adopts the 4th form, he is not living up to the contract, but is compelling the purchaser to enter into a new contract whether he wishes to or not.

To sum it up in a few words, the manufacturer should deliver the goods he agrees to whether he does at the beginning of the contract or when the contract is half completed. Yours very truly,

GEO. A. CLARK.

KEOKUK, Ia., Sept. 19, 1899.

Editor of THE JEWELERS' CIRCULAR:

In reply to your circular letter regarding filled cases: When a manufacturer puts a guarantee on a case, the warrant should be made good for the full amount of time, or else a new case given in exchange.

We have no suggestions to give as to question two; this should lie with the manufacturers.

To repair a case or give a new one and charge for the length of time case has worn, in our opinion, would never be satisfactory to either wearer or retailer.

Yours truly,  
T. R. J. AYRES & SONS.

ELYRIA, O., Sept. 19, 1899.

Editor of THE JEWELERS' CIRCULAR:

Your circular letter of the 8th regarding the guarantee on filled cases is at hand and I take pleasure in replying.

Experience has taught that there are two classes of so-called filled watch case makers: One of these, and I am glad to say the smaller class, makes a case which they know or should know from the small quantity of gold it contains, cannot and will not wear one-half the length of time



## Our New.... Jewel Case



has been pronounced  
by competent judges  
the best in size, shape,  
workmanship and fitting,  
in the market.

Roy Watch Case Co.,

Makers of SOLID GOLD CASES,

21 Maiden Lane,

New York.



TRADE-MARK REGISTERED.

the guarantee calls for. In this class are to be found several jobbers of watches who contract with manufacturers for certain grades of cases with a small or inferior quantity and quality of gold and furnish their own guarantees. Many of these cases are deceptive in appearance, but in time their true worth is known. For this class of people I think form No. 1 should be insisted upon, and applied as many times as are necessary to fulfill the promise of their guarantee.

The other class of case makers puts up a case with a sufficient amount of gold properly distributed on the parts subjected to the greatest wear, to fulfill the promise of its guarantee, when used in a reasonable manner by the average watch carrier.

These are the honest case makers, who propose to give value received in every case they make. But even they, like other people, "have troubles of their own" and occasionally a case is returned to them showing defect or hard usage. In this instance I think that form No. 3 is reasonable, just, and equitable to both manufacturer and wearer. Suppose this manufacturer should distribute at the same time 100 20-year cases all alike to as many wearers. After the lapse of 15 or 18 years 10 of these cases are returned showing the base metal, the other 90 having lived out the 20-year guarantee. It will be found with every one of these 10 returned cases that they show harder usage or more wear than the other 90 cases in use 20 years. This is owing to the daily occupation and habit of the watch carrier or the lining of the watch pocket and condition in which it is kept, whereby the metal is cut or worn away quickly. The stone cutter or the man who labors over an emery wheel every day or who allows dust and grit to accumulate in his pocket, cannot reasonably expect his case to wear for a long period. Then neither the case nor its manufacturer is at fault, but the wearer himself in the majority of failures. If then the wearer can be so fortunate as to have his case put into good repair and condition to live out the guarantee, he should be *entirely satisfied*, and at the same time impose no injustice on the manufacturer, who has honestly given him a case which under ordinary conditions and circumstances and in other hands would have lived out its guarantee. Yours respectfully,  
C. R. BICKFORD.

CARROLLTON, O., Sept. 21, 1899.  
Editor of THE JEWELERS' CIRCULAR:

There are cases made by certain manufacturers that are O. K. and they will replace a poor case. Many concerns make inferior cases and "guarantee them just as good." Now, such concerns should be compelled to replace or forced out of business. A manufacturer has no more right to misrepresent than has the peddler.  
Yours,  
J. W. HELFRICH.

PORTSMOUTH, N. H., Sept. 20, 1899.  
Editor of THE JEWELERS' CIRCULAR:

In reply to your questions, would say:  
No. 1. The manufacturer should.  
No. 2. No. 3. No. 4. No.  
Yours truly,  
JAS. R. CONNELL.  
(Series of letters to be continued.)

WE desire to call the attention of those buying early this season to our large and complete line of guard chains suitable for the long-nette, watch, fan, muff, purse, or for use as an eye-glass chain, and especially to the many new patterns of chains and slides we are showing. We have borne in mind the tendency toward heavier chains, and are showing some patterns which at this date we believe cannot be duplicated elsewhere.

B. A. BALLOU & CO.,  
Providence, R. I.

THE STANDARD CASES

ARE THE

Bates & Bacon Gold-Filled Watch Cases

FAVORITE,	ROYAL,	REGAL,	PURITAN,
14k. FILLED,	14k. FILLED,	GUARANTEED	GUARANTEED
Guaranteed 25 Years.	Guaranteed 20 Years.	10 YEARS.	5 YEARS.

BATES & BACON,

103 STATE STREET,  
CHICAGO.

11 JOHN STREET,  
NEW YORK.

Stern Bros. & Co.,

Cutters of . . .

MANUFACTURERS OF

DIAMONDS, Gold Rings and Thimbles,

68 NASSAU STREET, NEW YORK.

RING FACTORY, 33-43 GOLD STREET, NEW YORK.

LONDON OFFICE, 29 ELY PLACE.

DIAMOND-CUTTING WORKS, 142-146 W. 14TH ST., NEW YORK.

CHICAGO OFFICE, 149 STATE ST.



THE MAUSER MFG. COMPANY,  
SILVERSMITHS,

"Watch Our Ads." 15th St., bet. Broadway and Fifth Ave., New York.



# OPTICAL DEPARTMENT.

Note.—From this week till further notice this department will be run as usual, viz.: every other week.

## Encyclopedia-Dictionary and Reference Handbook of the Ophthalmic Sciences.

Copyrighted 1898, by The Jewelers' Circular Pub. Co.

BY R. H. KNOWLES, M.D.

[Commenced in issue of July 6, 1898.—Continued from  
page 41, Dec. 27, 1899.]

### PART XLIII.

**Malus, E. L.** Born in France in 1775; died in 1812. His discoveries include the polarization of light. He advanced the proposition "that particles of light have poles." His works are: "The Theory of the Double Refraction of Light in Crystals," and "Treatise on Optics."

**Marginoplasty** (*mar-gin'-o-plas-ty*). [Latin, *margo* = the margin + *plasseo* = I form.] That branch of surgical science which has for its object the replacement of a portion of the margin of the eyelid.

**Mariotte's Experiment** (*mar-i-ottes ex-per'-i-ment*). [Proper name + Latin, *experimentan* = to make a test.] This consists of marking a cross and black circle, of the size of a cent, four inches apart upon white paper. The attention should be directed to the cross and the paper upon which the cross and black circle are delineated be moved slowly backward and forward from the eyes. The circle will appear, disappear and reappear, in making the test, thus demonstrating the fact that the optic disc is a blind spot, as the disappearance of the black circle is due to its passing and covering that area of the fundus of the eye in which the optic disc is located. The total eclipse of the black circle demonstrates the fact that the optic disc is lacking the percipient elements of the retina, namely the rods and cones or Jacob's membrane. Mariotte's Spot is the optic disc or that part of the optic nerve which is seen by means of the ophthalmoscope. It enters through the several coats of the eyeball, is the only nerve seen and is the one physiological blind spot in the eye.

**Maturation** (*mat-u-ra'-tion*). [Latin, *maturare* = to mature, to make ripe.] That condition in which a body is said to be ripe. The maturation of a cataract is said to be at a period when the entire crystalline lens is opaque and dry, and the iris is free and movable. Then the operation for its removal should take place.

**Maxillo-palpebralis Muscle** (*max'-illo-pal-pe-bra'-lis mus'-cle*). [Latin, *maxilla* = the jaw + *palpebra* = the eyelid + *musculus* = a diminutive for mouse.] The circular muscle which covers the eyeball. It has its origin at the mesal margin of the orbit and its insertion at the side of the margin of the orbit, and when it contracts upon its origin, closes the eye. The nerves

which control its movements are branches from the facial nerve. Synonym: **Orbicularis Palpebrarum Muscle**.

**Maxwell's Spot** (*max'-wells spot*). [Proper name + Anglo-Saxon, *spitu* = a spear.] A name given to the image seen while blue glass is allowed to pass with great rapidity in front of the eyes. Maxwell's electromagnetic theory of light takes the supposition that waves are thrown off at right angles to the rays pursuing a direct path and that these produce the phenomenon of light.

**Mechanism** (*mech'-an-ism*). [Greek, *mechane* = a tool.] That which pertains to the way a process is carried out; also the various parts of which an organ, instrument or machine is composed. The mechanism of accommodation consists of the crystalline lens, suspensory ligament, and the ciliary body, and is sometimes spoken of as the accommodative apparatus. The method or process by which the amplitude of accommodation is made possible is the contraction of the ciliary muscle upon its origin, the Canal of Schlemm, so that the crystalline lens attains its maximum amount of convexity for the near point. When, however, the eyes gaze into infinity, the radiate fibres of the muscle of accommodation flatten the crystalline lens and the eyes are at rest and are in parallelism. This applies to an emmetropic eye.

**Medium** (*me'-di-um*). [Latin, *medius* = the middle.] That through which something acts or moves. The dioptric media or the transparent parts of the eye consist of the cornea and the three humors.

**Megalocornea** (*meg-al-o-cor'-ne-a*). [Greek, *me-gas* = big + *cornea* = the cornea.] A morbid state of the cornea in which the structures become enlarged.

**Megalopia** (*meg-al-o'-pi-a*). [Greek, *me-gas* = large + *ops* = eye.] An entoptic phenomenon in which an object appears to be larger than it really is, due to spasm of the muscle of accommodation or the results of scars from an old retinitis. Synonyms: **Macropsia; Megalopsia**.

**Megalopsia** (*meg-al-op'-si-a*). [Greek, *me-gas* = large + *ops* = an eye.] A pathological condition of the eye in which an object appears to be larger than it really is. This state is one of the several entoptic phenomena, a peculiarity within the eye itself, and is often the result of an old inflammation of the retina, in consequence of which the rods and cones become enlarged, caused by adhesive bands of lymph putting the same upon the stretch; while the object may appear larger, it is not correspondingly distinct.

**Megascop** (*meg'-a-scope*). [Greek, *me-gas* = large + *skopeo* = I see.] A microscope employed for the purpose of examining large objects.

**Meibom, Heinrich.** Born in Germany, 1638; died in 1700. A celebrated German

anatomist of the seventeenth century. A number of anatomical parts of the human body are named after Dr. Meibom. The Meibomian glands are a row of little glands lining the inner margin of the upper lids; they have the appearance of very small pearls and are for the purpose of secreting an oily substance the purpose of which is to lubricate the eyeball and also to prevent the tears from overflowing. When these glands become stopped up, a small, movable tumor (a chalezion) results.

**Melasma Palpebrarum** (*mel-as'-ma pal-pe-bra'-rum*). [Greek, *melas* = black + Latin, *palpebra* = the eyelid.] A discoloration of the eyelid during certain general conditions such as occur in pregnant women.

**Membrana** (*mem-bra'-na*). [Latin, *membrana* = a membrane.] An enveloping tissue which covers some part or organ of the body. Membrana Arnoldi or Arnold's membrane of the iris contains pigment cells. Membrana Amphiblastroidius is a synonym for the third coat of the eye, the retina. Membrana Bacillaris is the layer of rods and cones, the ninth layer of the retina. Jacob's Membrane is the Bacillar Membrane. Membrana Bowman is the upper layer of the cornea. Membrana Bruchii or the membrane of Bruch is the external layer of the choroid coat of the eye. Membrana Ceratodes is another name given to the cornea. Membrana Coronae Ciliaris, or the suspensory ligament, holds the crystalline lens in its place and is enclosed within the grasp of the ciliary body; synonym: The Zone of Zinn. Membrana Descemetis, or Descemet's membrane, is the fifth layer of the cornea, the posterior lamina (Valk). Membrana Foraminalis (synonym: iris), another ciliary process of the ciliary body. Membrana Hyaloidei is the surrounding membrane of the vitreous humor. Membrana Jacobi is the ninth layer of the retina (Gray), or the rods and cones. Membrana Limitans Interna is the first layer of the retina (Gray). Membrana Limitans Externa is the eighth layer of the retina (Gray). Membrana Pigmenta is the choroid or pigmentary coat of the eye, especially that portion of it which lies nearest the ciliary muscle. Membrana Pupillaris is a transparent covering of the pupil in an unborn baby. This membrane disappears several months prior to birth. Membrana Reichertis is the outer layer of the cornea, sometimes called Bowman's Membrane. Membrana Tenonis consists of fasciæ which surround the eyeball and prevent the eyes from touching the other tissues of the sockets. It lubricates, protects and supports the eyeball in its place within the orbit. Membrana Vascularis, or the vascular coat of the eye, is the same as the choroid coat. Membrana Vitrei is the fifth layer of the cornea, the posterior epithelial layer (Valk). Membrana Zinnuli is the suspensory ligament, also called the Zone of Zinn.

(To be continued.)

B. W. Post did not open a jewelry store in Washburn, Ill., as he intended to do. After buying his stock of goods in Chicago he received an offer from a jeweler in Hickman, Ky., and soon concluded to accept it. He shipped his goods from Washburn to Hickman and followed them

## A NEW METHOD

IN MAKING

### Travelers' Watch and Ring Trays

ENABLES US TO PRODUCE THE

**STRONGEST TRAY EVER MADE.**

Guaranteed for One Year.

FOR FULL INFORMATION, WRITE OR CALL.

## S. VALFER & CO.,

Manufacturers of FINE CASES AND TRAYS for Jewelry and Silverware,

33 MAIDEN LANE, NEW YORK.

## Our Hand-made Cases

are constructed in the old reliable way, which is a pride to the Manufacturer, Dealer and Wearer.

STAMPED.



18 K.

ALL CASES BEARING THIS MARK,  
ARE HAND-MADE.

STAMPED.



14 K.

Manufactured by

### DUBOIS WATCH CASE CO.,

Makers of

### SOLID GOLD CASES.

21 and 23 Maiden Lane, New York.

These well-known Razors, the quality of which is warranted, possess this great advantage, that they may be used for ten years before they require actual sharpening. Before using them it is necessary to rub them on good leather strop. Le Coultre's Strops (to be had with the Razors) should be used in preference to others.



"SPECIAL"—Single Razors for Jewelers' Travelers at trade price.

## MATHEY BROS., MATHEZ & CO.

Send for Price List.

Sole Agents, 21 & 23 MAIDEN LANE, N. Y.



## Eliassof Bros. & Co.,

IMPORTERS AND JOBBERS OF

### DIAMONDS, WATCHES, JEWELRY,

9-11-13 Maiden Lane,

Materials, Tools and Optical Goods.

NEW YORK.

ALBANY OFFICE: 62 & 64 STATE STREET.



GOLD SHELL.

*'Buy direct from the manufacturer and get all that is coming to you.'*

SEND FOR OUR "HOT CATALOGUE, CONTAINING GOLD FACTS AND PRETTY PICTURES."

**CLARK & COOMBS,**

86 WEST EXCHANGE ST.,

PROVIDENCE, R. I.

WE ARE HEADQUARTERS FOR.....

**Gold Shell Rings...**

## Workshop Notes.

**Fly-Proof Gilding.**—Boil three or four onions in half a liter of water, and spread this preparation by means of a brush on the gilt frames, clocks, etc., which will not be affected in any way. You may be sure that the flies will keep aloof.

**Cleaning Blackened Silver Ware, Etc.**—

It frequently occurs that household and other utensils become blackened by acids. The following is a method for cleaning them: Take carbonate of soda 20 parts by weight, acetic acid five parts and water 500 parts. Dissolve the carbonate of soda in the boiling water, add the acetic acid and scour the pieces in the bath. Rinse well and dry.

**Jewelers' Plaster Models.**—To impart hardness and polish to the plaster models, boil them for one-half hour in a bath composed of 200 grammes of alum per liter of water, to which five grammes of sulphuric acid are added. At the end of 30 minutes withdraw the plaster objects and allow them to cool. Then saturate them several times with the remainder of the bath, and allow them to dry. The alum will appear crystallized on the plaster. A good brushing, either by the lathe or by hand, will give the polish.

**To Harden Files.**—Cooking salt 21 parts, crushed white glass 1-10 part, animal charcoal  $\frac{3}{4}$  part, rye-flour  $\frac{1}{4}$  part, colophony  $\frac{1}{4}$  part, powdered charcoal 1-5 part, yellow prussiate of potash 120 parts. Make a paste of the finely powdered ingredients with alcohol and with this thickly coat the files, by means of a brush, before laying them into the fire. If, in heating, particles of the coating should crack off, quickly sprinkle a little yellow prussiate of potash on these places. After the file has been sufficiently heated dip it slowly, without moving it to the right or to the left, into the hardening water.

**To Remove Gold from Glass or Porcelain.**—For removing the gold from articles of glass or porcelain, it suffices to put them for some time in aqua regia, that is to say, until the gold has completely disappeared. If one has to treat broken objects, they have to be reduced into very small pieces, in order to put them into an earthen strainer as is used by the gilder, and allowed to remain in aqua regia as above mentioned. Next they are to be washed several times in clear water, the water from the first washing being added to the aqua regia, so as not to lose the gold which might be in the wash-water.

**To Clean Old Coins and Medals.**—

The following process is recommended for cleaning coins or medals of silver or bronze without impairing their numismatic value: Prepare a bath composed of nine parts of rain water and one part of sulphuric acid. Place the coins in this bath for the time required to dissolve the sulphide which has blackened them. Five to 10 minutes are usually sufficient. After removing them, plunge them into clear water; next wash them with soap, using a soft brush. When they are clean move them about once more in the water, dry them with a soft cloth and finally give them another treatment with chamois cloth without rubbing too hard.

DEPARTMENT OF  
ADVICE AND CRITICISM  
ON  
RETAIL JEWELERS' ADVERTISING.

[This department is free to every retail jeweler and optician. Forward for criticism your newspaper ads., booklets, catalogues, novelties, circulars, etc. Ask advice and offer suggestions. Replies in these columns are unbiased. Make letters full and particular as desirable. Every letter and ad. sent will receive full attention, though the publication of the matter may sometimes be delayed some weeks. Address all letters and other matters to The Jewelers' Circular Pub. Co., 11 John St., corner Broadway, New York.]

PART LXXXII.

STAUNTON, Va., Nov. 14, 1899.

Editor of THE JEWELERS' CIRCULAR:

Kindly comment on enclosed ad. at your convenience.

Very truly,

SWITZER & GRUBERT.

Take a good  
look at our  
line of - - -

**Jewelry**

And see if it isn't as beautiful and as elegant as you ever saw. If you have an eye for what is beautiful, if you are quick to appreciate harmony in designs like notes in music, if you know values, then come here and select your Jewelry.

The goods we have ordered are now displayed to our customers and are of the very best quality and latest designs.

SAVE A FEW DOLLARS  
AT OUR EXPENSE.

SWITZER & GRUBERT,  
Jewelers.

The ad. referred to is reproduced both as to style and size. Taking into consideration the date the ad. was published—Nov. 14—it was a general announcement that undoubtedly affected those who contemplated buying some jewelry pieces as holiday gifts. The display is good, while the phraseology is graceful, refined and effective. The omission of the jewelers' address is a defect.

CUYAHOGA FALLS, O., Nov. 15, 1899.

Editor of THE JEWELERS' CIRCULAR:

Enclosed find a 4-inch ad.; also some reading notices. This is the amount I have in our weekly every week, but it is changed each week, and after trying many ways I find I get better results by this class of advertising. I send this as a sample.

Very truly,

B. F. PHILLIPS.

Mr. Phillips's advertisement is reproduced as nearly exact as possible. Its object is evident and the contrast between buying in the large city and buying locally is tersely and convincingly expressed. Merchants of the small cities and towns should do all they can to make the public patron-

ize home industries, and undoubtedly rehearsing the evils of city shopping by ad-

How is?  
This....?

Crowded Cars  
Careless Clerks  
Lots of Dirt  
Big Prices  
Tired Out

That is Shopping in the  
City.

Light Store  
Easily Reached  
Polite Service  
Big Assortment  
Living Prices

That is Shopping with  
**PHILLIPS**

The Up-To-Date Jeweler,

Cuyahoga Falls, - - - Ohio.

vertising is calculated to achieve this end. The locals referred to in the letter are:

Phillips, the jeweler, will receive a wagon load of clocks next week that were contracted for before the advance in prices, and what makes a nicer Xmas present than a fine parlor clock?

IF YOUR WATCH FAILS ONCE

It is liable to do so again, unless the defect is discovered and remedied. All repairs intrusted to me are done promptly, reasonably and satisfactorily.

Phillips, the Jeweler.

Election is over and now is the time to buy a good Dueber-Hampden watch of Phillips and have a good time the balance of your life.

The handles of all the fountain pens sold by Phillips, the jeweler, are engraved and inlaid in white, free of charge. Call and see samples.

These were printed in the regular type of the newspaper. They are all cleverly worded.

A story is told about an old Southern colored man who came to a watchmaker with the two hands of a clock.

"I want yer to fix up dese hands. Dey ain't kept on correct time for mo' den six monfs."

"Well, where is the clock?" responded the watchmaker.

"Out at my house."

"But I must have the clock."

"Didn' I tell yer dar's nuffin de matter wid de clock 'cepting de han's? An' here dey be. You jest want de clock so you kin tinker wid it and charge me a big price. Gimme back dem hands," And so saying, he started off to find an honest watchmaker.—New York Tribune.

PRIZE ESSAYS

—ON—

JEWELRY STORE KEEPING.

The Jewelers' Circular, continuing its policy to offer from time to time, prizes for essays on matters connected with the conducting of a retail jewelry business, inaugurates a forthcoming series by offering the following nominal

PRIZES FOR SUBJECTS.

Prize \$5.00—For title of Best Topic for competition on any matter connected with the running of a jewelry store.

Prize \$3.00—For title of Next Best Topic.

For each title of the Next Five Best Topics, a year's subscription to THE JEWELERS' CIRCULAR.

Competitors may send in as many TITLES OF TOPICS FOR COMPETITION as they desire, but only one will be selected for the prize competition; that is, no competitor can win more than one prize.

[All Topics must be in by Jan. 28.]

Jewelers' Ideas and Schemes.

Ludwigs & Hunziker, Walla Walla, Wash., have been giving away free with every sale amounting to \$1 or over a pair of sterling silver top salt and pepper shakers.

J. S. Townsend, 1554 Wabash Ave., Chicago, has issued a unique thing in jewelry literature. It is a flat, embossed card the size and shape of a German beer mug with cover. Upon lifting the lid, a monk rises from the stein and attempts to kiss a pretty maiden.

At Hot Springs, Ark., Miss E. D. Rice won a prize by writing the words "De-Long, the Jeweler," 1,263 times on the back of an ordinary postal card.

A second prize has been announced in the contest for the Harrisburgh (Pa.) Star-Independent's trophy for the most popular employe of the Pennsylvania Steel Co., Steelton. E. L. Egoal, jeweler, has offered a fine full jeweled watch of the best movement in a gold filled case, the whole of the value of \$50.

D. C. Bixel, jeweler, Bluffton, O., says in a "local" in the Bluffton News, of Dec. 21, 1899:

A ton of diamonds is worth \$35,000,000, more or less. We do not expect that you will favor us with such an order, but our line of diamonds, purchased to fill the requirements of the holiday season, offers opportunities for the selection of the most simple and modest to as high as you care to go.

This is a cleverly worded item. About eight years ago THE CIRCULAR in a jocular paragraph gave the value of a ton of diamonds as \$35,000,000. This value was seriously accepted by certain publications of reference, among them the annual almanac of the Philadelphia Times, and here again it "bobs up serenely." Our joke evidently was one on us.

# PAIRPOINT MFG. CO.,

NEW BEDFORD, MASS.



New Line for 1900 ...in... Preparation.

Silver  
Plate  
AND

Rich...  
Cut Glass.

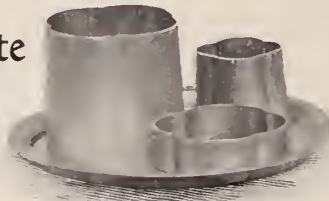

38 Murray St., New York City: Temple Building, Montreal.

## CLYDE LINE

### TO FLORIDA

ONLY DIRECT WATER ROUTE BETWEEN  
NEW YORK, CHARLESTON & JACKSONVILLE

SUPERB PASSENGER SERVICE	WITHOUT CHANGE SAILING FROM PIER 45 N.R. NEW YORK	THREE SAILINGS WEEKLY
--------------------------------	--	-----------------------------

W<sup>M</sup> P. CLYDE & CO., General Agents.  
Theo. G. Eber, TRAFFIC MANAGER, 5 BOWLING GREEN, NEW YORK.

# Edward N. Cook,

## Plated Seamless Wire and Aluminum Solder.

144 PINE ST., PROVIDENCE, R. I.

**ESSER & BARRY,** Largest Manufacturers of  
... Cheap and Medium Priced  
**IMITATION DIAMOND JEWELRY**  
IN AMERICA.

Write us for samples of almost anything with an Imitation Diamond in it.  
MAIN OFFICE AND FACTORY, 101 SABIN ST., PROVIDENCE, R. I.

### SOUVENIR SPOONS

We are up to the cash buyer. If you are a cash buyer, you must have our special circular on souvenir coffee spoons for cash buyers. We won't give you time, but we will give you price. No jeweler can afford to be without this circular, nor neglect to give us a chance to quote prices in the way of souvenir spoons or souvenir novelties. We have everything in this line.

**SIMMONS & PAYE,**  
"The Souvenir House,"  
129 Eddy Street, Providence, R. I.

## DR. KNOWLES' ...PRIVATE COURSE IN... Optometry.

SPECIAL RATES IN THE  
CORRESPONDENCE DEPARTMENT.

**"EYE DEFECTS,"**

A New Book, in cloth, Price, \$1.00.

For terms and important particulars, write to  
**R. H. KNOWLES, M. D.,**  
11 John Street, New York.

ESTABLISHED 1840  
**SIMONS BROS. & CO.**  
PHILA. NEW YORK CHICAGO  
SILVERSMITHS, JEWELERS.  
MAKERS OF GOLD AND SILVER THIMBLES.

**FERD. FUCHS & BROS.,**  
**SILVERSMITHS,**  
MAKERS OF STERLING SILVERWARE,  
34 East 29th St., - New York.

**WOOD & HUGHES,**  
Sterling Silverware Manufacturers,  
FINE PLATED WARE,  
No. 24 John Street, - New York.

**DEITSCH BROS.,**  
14 East 17th St.,  
New York.

LEATHER. SHELL,  
EBONY, IVORY.

**JACOT & SON, IMPORTERS.**  
**STELLA AND  
IDEAL  
MUSIC BOXES.**  
69 UNION SQUARE, - N. Y.

**THE LEDOS MFG. CO.,**  
MANUFACTURERS OF  
**Watch Case Materials,**  
Crowns, Pendants, Bows, Solders,  
Springs, Findings, Etc.,  
34-36 PEARL ST., NEWARK, N. J.





## 'Antique Goblets and Drinking Vessels.

(Continued from issue of Jan. 3.)

CUPS had frequently distinguishing names and titles; thus, Richard, Earl of Arundel, in 1392 bequeaths to his wife Philippa her own cup, called "Bealchier;" while another nobleman of a rather earlier date has a cup of gold with an acorn, called "Benessoune," and another which went by the name of "Wassail."

In the middle of the 15th century we find the Prior of Durham mentioning one of his drinking-vessels as "Beda," and another as "Abell." The standing cup and cover which was sometimes placed on the table, and at others was handed to the lord when he chose to drink, is called a hanaper in Lord Latimer's will in the year 1381—"le grant hanaper d'argent endoeré appellé Seint George."

The constant fear of poison in which the richer classes stood in former times is often illustrated in the manufacture of drinking-vessels. It was believed that cups made of the horn of the narwhal had the power of detecting poison. Frequent use was made of turquoises, amethysts, crystals, and other precious stones in ornamenting goblets, with some such idea beyond the ostensible purpose of decoration. Queen Elizabeth's silver-gilt cup, standing on three knobs, has its cover, sides and knobs covered with amethysts of various tints, the interstices being filled with small turquoises.

Precious stones were believed to be endowed with many mystical qualities. The turquoise was supposed to have the power of strengthening the eyes, and was also of use in detecting the presence of poison, by becoming of a paler hue. The opal, however, in the goblet of Pope Alexander VI. did not avail him in escaping the fate traditionally assigned to him. In a similar fashion, crystals of various kinds were believed to become clouded. Thus the so-called Poison Cup belonging to Clare College, Cambridge, has a crystal mounted in the center of the lid. In a translation of Petrarch's "Phisicke against Fortune" (published about 1579), we have a dialogue of "cuppes made of precious stones," in which one of the characters—"Joy" by name—is made to say, "I am desyrous to drynke in cups of precious stones;" to which "Reason" replies, "Perhaps there is some other cause of so fervent desire: for it is not the glistening only that allureth thee, but some hydden virtue, for who is able to declare all the operations and

virtues of precious stones?" And he adds: "There have been some that have beleevved that by virtue of this stone [the amethyst] promysing them sobrietie they might boldly quaffe without fear of drunkennesse."

The Duke of Anjou possessed 39 gold and silver goblets in the 14th century; and Charles V. of France had fully as many, and among them one of jasper. Crystal ones were in use, and a sapphire surmounted the cover of a goblet belonging to the Queen of Philippe le Bel. While the French King John was a captive in England, we find him paying to a certain John Corbière, a goldsmith of London, three hundred and nine moutons d'or for a goblet weighing nearly six marks, from which he drank until the English kings graciously sent him his own as a present. The memento given by Pope Clement to the unfortunate Charles VI. took the form of a goblet of rock-crystal mounted in gold.

A gilt cup in the shape of a lamp figured in the trousseau of Mary of Burgundy, Countess of Cleves, at the commencement of the 15th century; and we have notice of another made like a candlestick. Cups of the Elizabethan age were occasionally fashioned as gourds or melons, with feet formed as their twisted stems and tendrils. At times they were made to represent birds, as the "Cockayne" cup belonging to the Skinners' Company, presented by the widow of a gentleman named Peacock.

One of the finest examples of the goldsmith's art in Stuart times is the Royal Oak Grace Cup, presented to the Barber Surgeons' Company by Charles II. It is over 16 inches high, and formed as an oak tree, the trunk and branches supporting the bowl, while the royal crown serves as a cover.

During the 16th and following century the quaint Wager or Surprise Cups were in fashion. A familiar example of these takes the form of a woman holding a smaller cup over her head, with arms upstretched, the object of the drinker being to drain the contents of the larger cup without spilling the liquid in the smaller one. Another vessel used for betting purposes was the *Gobelet-à-moulin*, or windmill goblet, provided with a small whistle, which, on being blown, set in motion the sails of the mill; and before they had stopped working the cup was to be drained.

Grotesque forms were often given to drinking-vessels. Such are the grey-beards, or Bellarmine's, with their rotund

bodies, narrow necks, and Silenus-like masks in front, made of a greyish-colored stone ware, covered by a mottled brown glaze. Cardinal Bellarmine's countenance would appear to have been quite unlike these effigies; they seem to have been made in Holland when religious disputes were fierce, and may have been intended by one party to bring ridicule on the other. Another explanation is provided in the story of an Oxford student who, one day returning with a jug of ale under his cloak, on being questioned by a university official, replied that he had merely been to borrow the works of Bellarmine! These grotesque vessels are frequently referred to by writers of the time of Elizabeth and the earlier Stuarts.

Representations of misshapen human beings are to be found among the drinking-vessels of antiquity; and of a similar character is the Toby Pitcher, or image mug, produced in the Staffordshire and other potteries. Another curious bowl, of large dimensions, was styled a "Jeroboam," and was generally wrought of metal. The high-stemmed wine-glass of the 17th century was sometimes called a "Tall-boy."

(To be continued.)

## Costly Pipes.

THE most valuable pipes are used by Muzaffer-ed-din, the Shahinshah (King of Kings) and present ruler of Persia. His *kallian*, or state pipe, which he uses on special festive occasions, is estimated to be valued at \$400,000, and is ornamented with diamonds, rubies and emeralds of the costliest kind. Not only the mouthpiece and the upper and lower part of the snake-like tube, but also the pipe case consist of pure gold, all covered with large, sparkling diamonds. The Sultan of Turkey possesses very valuable pipes. When the Prince of Wales visited him in 1862, he was asked by the Sultan to smoke from a *nargileh* (water-pipe), which was studded with diamonds, and valued at \$15,000. This pipe was then presented to the Prince as a souvenir of his visit to Constantinople. A pipe, consisting mainly of meerschaum and amber, belonging to Prince Ferdinand, of Bulgaria, is said to have cost \$3,000.

**Imitation Platinum.**—Brass 100 parts, zinc 65 parts; or brass 120 parts, zinc 75 parts; or copper five parts, nickel four parts, zinc 1½ parts, antimony one part, lead one part, iron one part, tin one part,

CONSULT

“The New York Jeweler”

Before Buying Jewelry or Kindred Lines.

For 26 years the acknowledged authority for all that is new, artistic and beautiful in the Jewelry World.



An idea of the assortments illustrated is shown by the fact that there are over 1000 Designs in **Diamond Jewelry**; 2000 Designs in **Watches**; 3000 Designs in **Emblems**; 5000 Designs in **Gold and Silver Novelties**; and proportionate displays from our **Silverware, Clock, Cut Glass, Lamp, Musical, Photographic, Optical, Scientific Instruments, Leather and Fine Stationery Departments.**

724 Pages. Size, 9x13.

This profusely illustrated catalogue enables the dealer to make a better selection than the majority of travelers' stocks affords.

**S. F. MYERS CO.,**

MANUFACTURING and WHOLESALE JEWELERS

Myers Building, 48-50 Maiden Lane, New York.

Mention Dept. G 12 when sending for catalogue.

Survival of the Fittest.

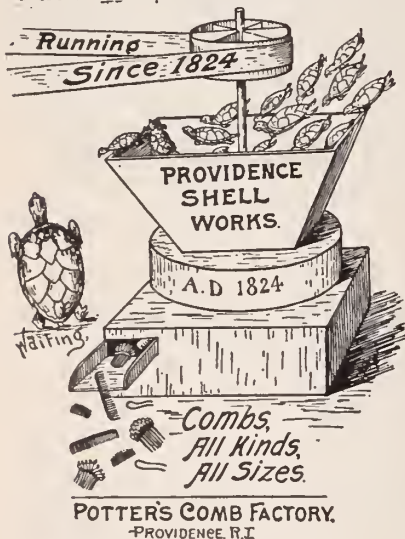

POTTER'S COMB FACTORY, PROVIDENCE, R.I.

We Grind for You, Send along your Work.

**W. C. A. WESTPHAL,**  
WATCHMAKER,

41 Maiden Lane, NEW YORK.

Established 1892. Telephone, 3684 Cortlandt. Estimates, Repairing, Adjusting of Chronometers, all Complicated Watches and Fine Time Pieces.

DEMAGNETIZING.

Watches made Non-Magnetic. Fine Wheel and Pinion Cutting

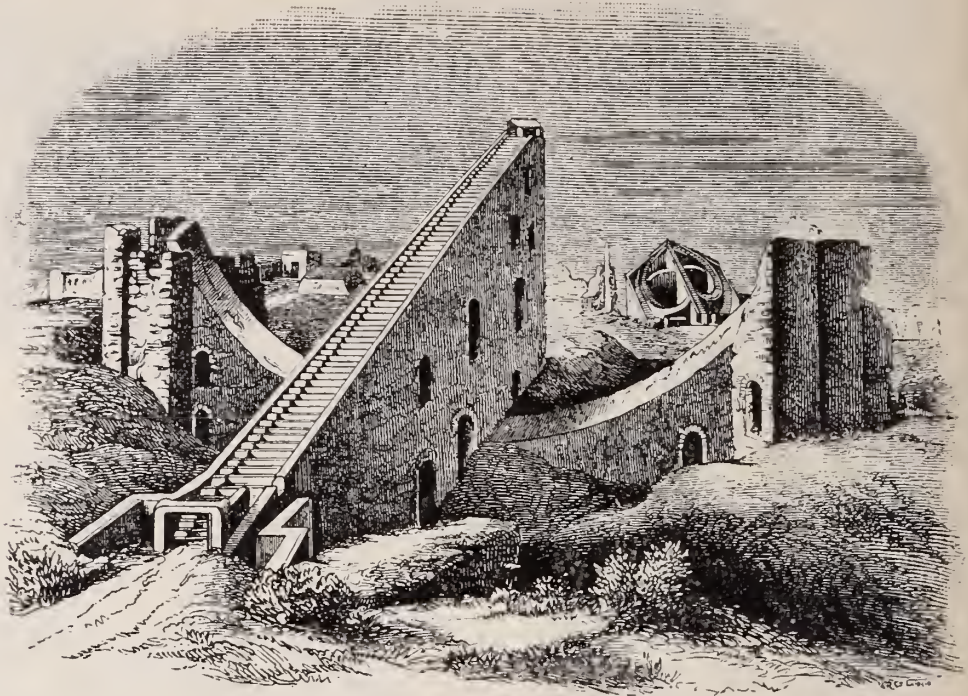

THE SUN DIAL OF THE JAVASINHA IN DELHI, INDIA.

Platinum Vessels.

PLATINUM crucibles and dishes are used on account of their great resistance to agents for fusing, calcining, evaporating, etc. Platinum, however, being by no means as unassailable as is generally presumed, it may be proper to give some points on the treatment of platinum vessels.

Platinum readily forms alloys with most metals, even at comparatively low temperatures and many of these alloys have the quality of melting at a very low temperature, as, for instance, the alloys with lead, tin, zinc, etc. Therefore metals must never be heated in platinum crucibles, and in the case of metallic compounds care should be taken that they are not reduced to metals. Platinum combines with iron at red heat and peculiar black spots appear which cannot be removed again in any way. To prevent the formation of this ferric alloy, placing the platinum crucible on an iron triangle for heating must be absolutely avoided. Hence, either the platinum wire triangles or clay triangles, *i. e.*, ordinary wire triangles over whose legs tubes of fireproof clay (Dutch pipe stems) are slipped, are employed for this purpose.

But also with phosphorus and silicium platinum promptly combines, forming fusible, brittle substances, for which reason a reduction process must be carefully avoided, when treating phosphates and silicates in platinum vessels. Platinum also possesses the unpleasant property of uniting with carbon, whereby frequently dull gray discolorations result on the outside of the crucibles, where they come in contact with the flame.

If a platinum vessel is blackened on the outside the soot must be burned off above the flame. If the spots are slighter, the vessel is rubbed down with damp sea sand (which consists only of round grains) and polished. Bad stains are removed by melting with bisulphate of potash and subsequent treatment with hydrochloric acid, but after this operation the crucible must again be polished with sea sand. For the cleaning of the crucible with sea sand the writer uses successfully wooden models which exactly fit the interior and exterior surfaces of the crucibles, whereby a bending out of shape of the vessels is avoided.

A Precious Gem Story.

THE tea things had been cleared away, and the head of the establishment was trying to read the evening paper, while his better half busied herself with some fancy work, and at the same time endeavored to interest him in the gossip of the neighborhood.

"Maria," said he, glancing up from his paper, "did you ever hear the story of precious gems?"

"Why, no," she replied; "what is it?"

"It's an old-time fairy legend that my grandmother told me when I was a boy," he continued, "about a woman from whose lips there fell either a diamond or a ruby every time she spoke a word."

"Well, go on," she said.

"That's all there is of it, Maria," he replied. "But I was just thinking that if such things happened nowadays I'd open a jewelry shop the first thing in the morning."

And then for 13 consecutive minutes silence reigned supreme.—Exchange.

American Watch Case Co.



Have Merit—Superiority—Reputation.

9 to 13 Maiden Lane, New York.



Our New Samples are ready for the Spring Trade.  
**"ACME"**  
 Lever Collar, Link and Sleeve Button.

STANDARD OF THE WORLD.

Manufactured in an Endless Variety of New and Original Designs.

We have made large additions to our already handsome and extensive lines in:

**CHAINS, RINGS, LOCKETS, CHARMS, BRACELETS AND EMBLEMS.**

See our line of EIFFEL PONY, FOB and DICKENS CHAINS.

Hearts, Ornaments, Medallions, Amulets and Tablets.



NEW SAMPLES OF NOVELTIES IN

Drop us a postal and our salesman will call. We sell the Jobbing Trade only.



New York Office,  
11 John Street.

**S. & B. LEDERER CO.**  
 FACTORY, PROVIDENCE, R. I.

Chicago Office,  
131 Wabash Avenue.

The **Remington** Billing and Tabulating Attachment accomplishes all kinds of Billing, Statistical, and Accounting Work on the New Models of the **Remington Standard Typewriter** as quickly and as accurately as ordinary typewriting is done. It automatically secures perfect perpendicular as well as horizontal alignment.

REMINGTON STANDARD TYPEWRITER

REMINGTON DEALERS EVERYWHERE SUPPLY IT.

**H. M. RICH & CO.,**  
 Jewelry - Auctioneers,  
 7 and 9 Franklin St.,  
 BOSTON, MASS.

# Push—Grit—Energy.

A long time ago we concluded that the only way to succeed was by practicing **Push**, showing **Grit** and never diminishing **Energy**. The result is shown in our

## 1900 Line of Jewelers' Findings

THEY INCLUDE  
 TUBE SETTINGS FOR COMBS, EBONY MOUNTS, PATENT CLUSTER SETTINGS.

### MEDALLION HEADS

FOR BROOCH PINS, BELT BUCKLES, LINK BUTTONS, ETC.

Large Scrolls for Picture Decorations and everything in Findings for the Manufacturer.

# HEIMBERGER & LIND,

158 PINE ST., METCALF BUILDING, PROVIDENCE, R. I.

"BY USING OUR GOODS, YOUR GOODS WILL SELL."

# CHAS. F. WOOD & CO., DIAMONDS

1 MAIDEN LANE, NEW YORK.

IMPORTERS AND CUTTERS.

## DIAMONDS.

LARGE ASSORTMENTS.

DESIRABLE SIZES.

ATTRACTIVE PRICES.

**R., L. & M. FRIEDLANDER,**

30 MAIDEN LANE, N. Y.

97 HATTON GARDEN, LONDON.

## HALL CLOCKS,

*Mantel Clocks,*

*Traveling*

*Clocks,*

*Clock Sets,*

*Regulators,*

*Bronzes,*

*Vases, Ivory*

*Miniatures*

*and Art Goods.*



Fall Line Now Ready.

**Harris & Harrington,**

32 and 34 VESEY ST., NEW YORK.

Sole Agents to the Trade for J. J. Elliott & Co., London.

IMPORTERS AND CUTTERS OF DIAMONDS  
 Arnstein Bros. & Co.

65 Nassau St.  
 NEW YORK.  
 Cor. John.

DIAMONDS and Cutters.  
 L. & M. KAHN & CO.,  
 172 Broadway,  
 Cor. Maiden Lane, N. Y.,  
 DIAMONDS

### BEER STEINS,

For Prizes, Club Use and Home Decoration.

75 Cents to \$4.50 Each.

**L. W. LEVY & CO.,**

Novelties and Optical Goods,

194 BROADWAY, NEW YORK.

Successors to Levy, Dreyfus & Co.

### HOROLOGICAL DEPARTMENT,

BRADLEY POLYTECHNIC INSTITUTE,

PEORIA, ILLINOIS.

Largest and best watch school in America. We teach Watch Work, Jewelry, Engraving, Clock Work, Optics. (Formerly Parsons' Horological Institute.) Catalogue Free.



### 38 YEARS OF HONEST RETURNS

IS OUR GUARANTEE OF SATISFACTION TO ALL OUR CUSTOMERS.

WE DO OUR OWN SMELTING.

**JOHN AUSTIN & SON,**

ASSAYERS, REFINERS AND SMELTERS,

74 & 76 Clifford St., Providence, R. I.

### TO BLOW EFFECTIVELY IS AN ART

which we never practice personally; but we have invented a machine which does it for us, called the

"Reichhelm Pressure Blower."

This, with Gas Furnaces and Jewelers' Tools generally, is the stock in trade of

**E. P. REICHHMEL & CO.,**  
 23 JOHN STREET, NEW YORK CITY.



GOLD AND SILVER PENCILS  
 PENHOLDERS, &c.



**FAIRCHILD & JOHNSON CO.**

Office and Factory,  
 220 FOURTH AVENUE, N. Y.

### Satisfaction

AND....

### Promptness

is the secret of our success. Our chief aim has always been to render prompt returns and to give satisfaction to all our customers.

**CONLEY & STRAIGHT,**

GOLD AND SILVER

REFINERS, ASSAYERS and SMELTERS,

236 Eddy Street, PROVIDENCE, R. I.

**ALOIS KOHN & CO.,** 4 MAIDEN LANE, SOLID GOLD CHAINS, Near Broadway, N. Y.

We call the attention of the Trade throughout the country to our line of

### LORGNETTE AND GUARD CHAINS.

Will send Samples on Memorandum on receipt of satisfactory reference. Correspondence Solicited.

**EMPIRE COMBS. SIDE COMBS.**

GOLD AND JEWELLED ORNAMENTED.

SPECIALTIES IN ROMAN WORK.

**DAY, CLARK & Co.,**

MAKERS OF FINE JEWELRY,

23 MAIDEN LANE, N. Y.

SEE ANNOUNCEMENT ON PAGE 28.

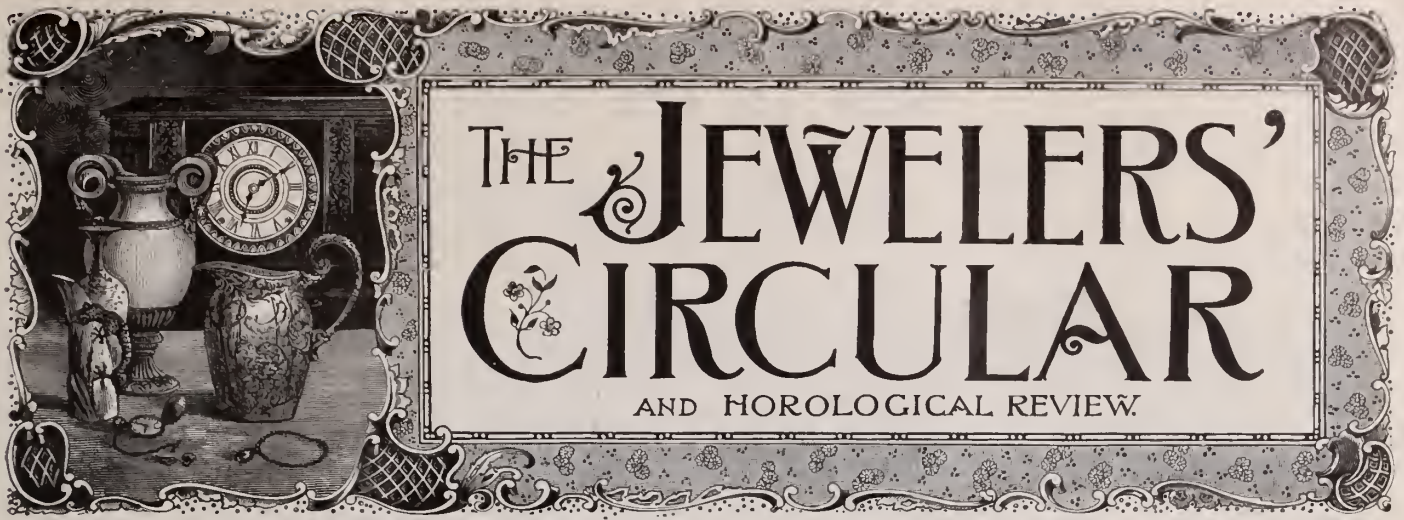

Corbin Building, 11 John St., Corner Broadway, New York.

Copyrighted by THE JEWELERS' CIRCULAR PUB. Co., 1900.

Entered at the Post Office in N. Y. as second-class matter.

VOL. XXXIX.

NEW YORK, WEDNESDAY, JANUARY 17, 1900.

No. 25.

**The Avery Spoon Collection.**

PART IX.

**G**ERMAN and Dutch.—XVIIIth and XIXth Centuries:—223, salt spoon,

dle; 227, salt spoon, long, twisted handle, figure at top.

*Modern Dutch.*—XVIIIth and XIXth Centuries:—228 to 255, scoops, tea caddy, salt and mustard spoons.

*German and Dutch Spoons.*—XVIIIth and

knotted handle, deer couched at top; 288, spoon, twisted handle, bird at top; 289, spoon, flat handle, bird at top; 290, spoon, chased handle, group "Charity" (?) at top; 291, spoon, plain handle, figure holding shield at top, gilt; 292,

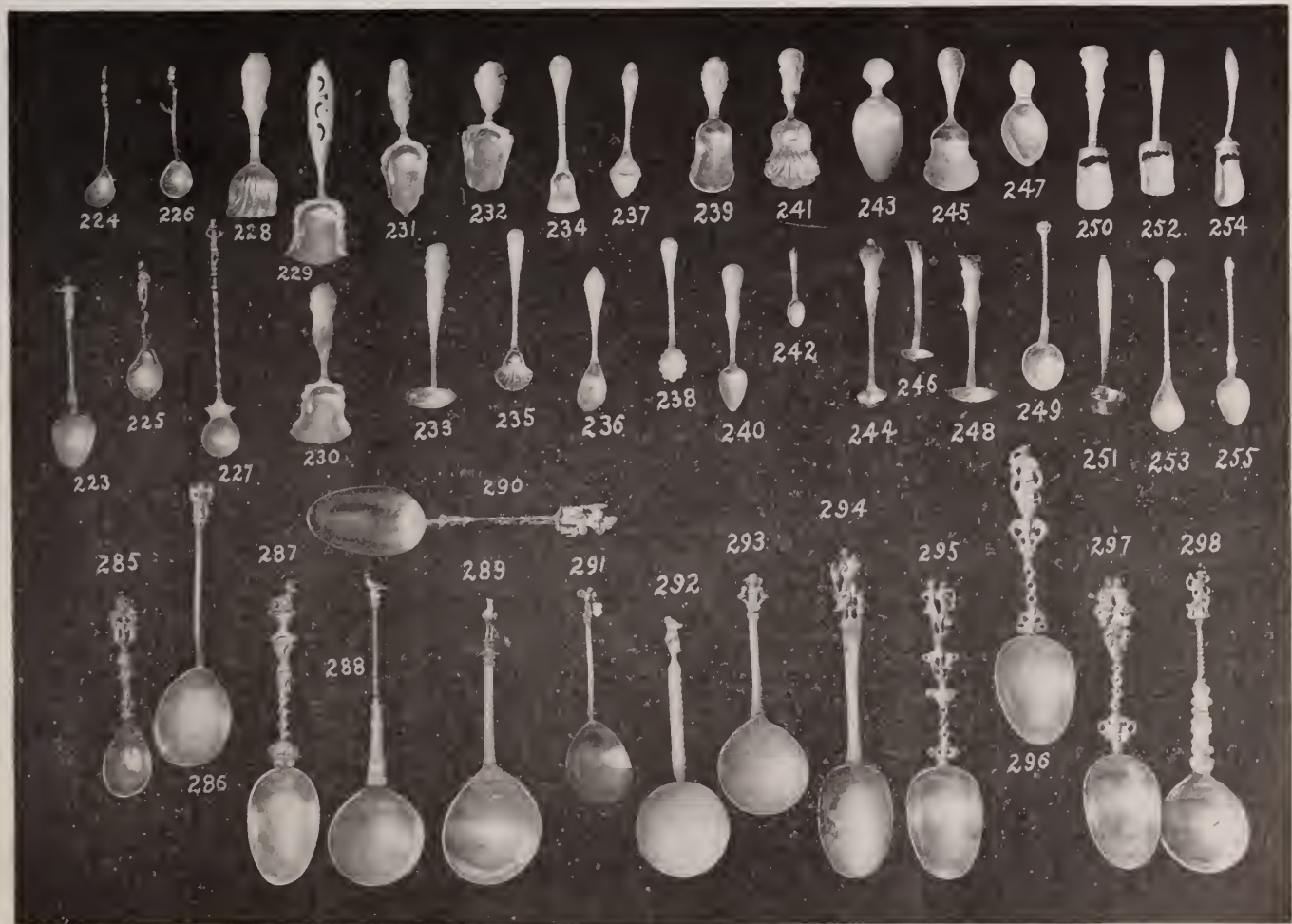

THE AVERY COLLECTION OF SPOONS AT THE METROPOLITAN MUSEUM OF ART. GROUP IX.

From photographs on sale at The Metropolitan Museum of Art Regrouped and Engraved by THE JEWELERS' CIRCULAR.

figure at top of handle, spade bowl; 224, salt spoon, mask at top of handle; 225, salt spoon, shell bowl, figure at top of handle; 226, salt spoon, ornament at top of han-

*XVIIIth Centuries:*—285, spoon, small, richly ornamented handle, gilt, mask below; 286, spoon, plain handle, figure with head-dress at top, Norwegian (?); 287, spoon,

spoon, flat handle, notched, small figure at top, suspension hook and ring back of handle; 293, spoon, plain handle, bust at top, engraved bowl; 294, spoon, flat han-

# Now Is The Time

to place orders for the Spring season's goods. Our lines are better and larger than ever, and include all that is desirable to complete the stock of a modern, up-to-date jewelry store. The *quality* is the *highest*, the *styles* are the *best*, and the goods are made expressly for the regular, all-the-year jeweler.

**Rolled Gold Plate and Gold-Filled CHAINS, BRACELETS, LOCKETS, CHARMS, PINS, EARRINGS, SILK RIBBON CHAINS, CHAIN MOUNTINGS, DUMBBELL BUTTONS, BROOCHES and BELT BUCKLES.**

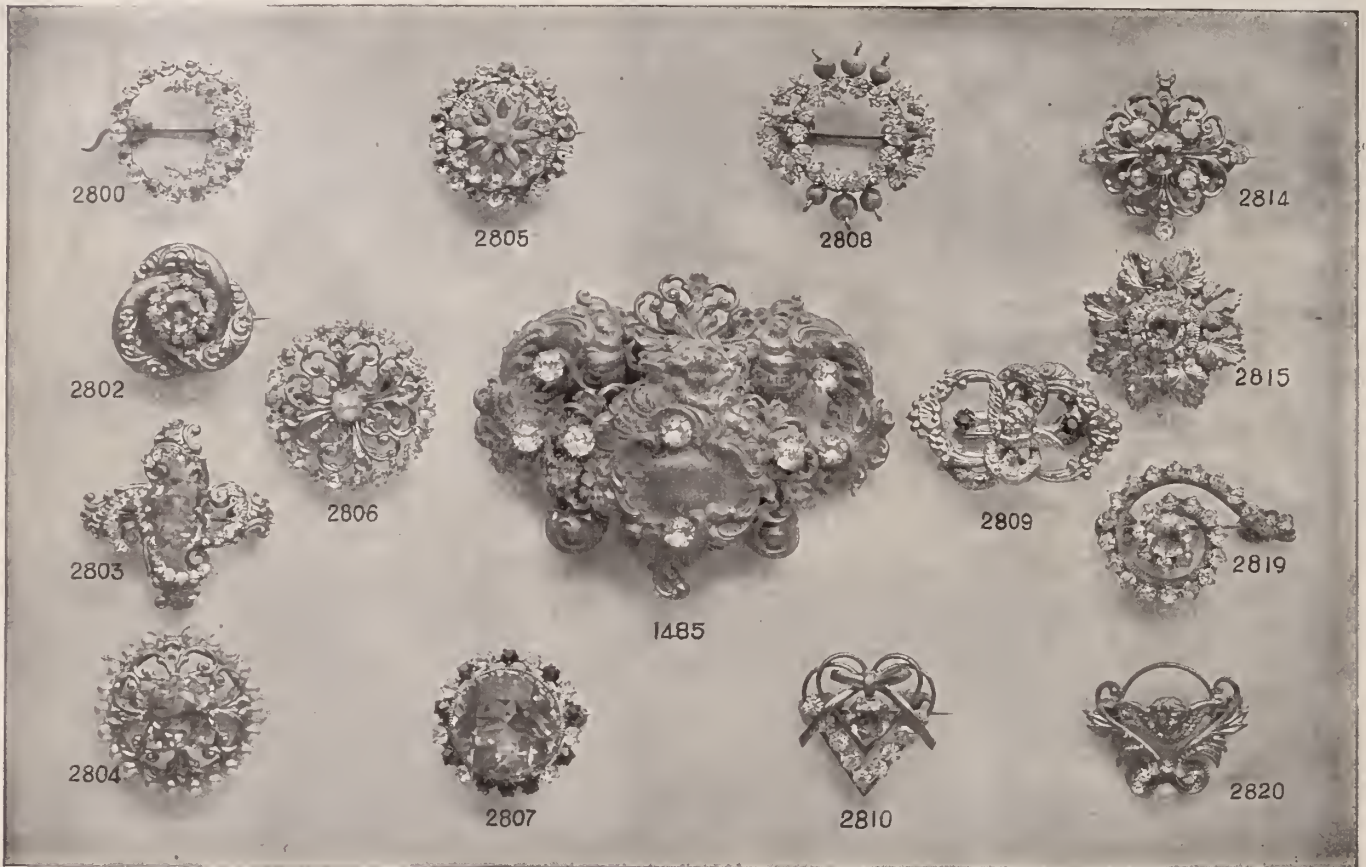

Our **STERLING SILVER TOILET and MANICURE ARTICLES** in the Washington, Jefferson, Victoria and American Beauty patterns are always in stock and can be matched or duplicated at any time.

**THEODORE W. FOSTER & BRO. CO.,** 100 RICHMOND ST., PROVIDENCE, R.I.  
Successors to FOSTER & BAILEY.

Established 1879. Manufacturer of

**LOUIS W. HRABA,**  **Fine Leather Goods**

29 East 19th St., New York. Exclusively for the Jewelry Trade.

**THE BASSETT JEWELRY CO.,**

Fine Gold-Filled Chains,  
Lockets and Gold Jewelry,

PROVIDENCE, R. I.

**AIKIN, LAMBERT & CO.,**  
MANUFACTURERS OF

**FINE GOLD PENS, HOLDERS, PENCILS,  
TOOTH PICKS and NOVELTIES.**

PAUL E. WIRT FOUNTAIN PENS, at new and lower prices . . .  
MERCANTILE FOUNTAIN PENS, guaranteed to give satisfaction.

Catalogues with terms and discounts furnished to the trade.

**BRANCH, 103 STATE STREET, - - - CHICAGO.**

**AIKIN-LAMBERT JEWELRY CO.,**  
IMPORTERS OF

**DIAMONDS.**

JOBBER'S IN

**WATCHES, JEWELRY, CHAINS,  
NOVELTIES, ETC.**

**LATEST DESIGNS. LOWEST PRICES.**

**19 MAIDEN LANE, NEW YORK.**

# A Prosperous Holiday Trade,

we hope, was your good fortune to experience.

The time consumed in the salesroom during that interval had a natural tendency to cause an accumulation of work, and possibly you ran short of material beforehand, did not have the time to order and do not now have sufficient supplies for your future requirements. If these were the conditions, we should like and hope that you will not overlook the fact that we are able to help you out.

We increased our stock considerably during December, our dull season, believing that there would be more than a normal demand later on, and we are now fully prepared to cope with all emergencies that may arise and to replenish your stock in all departments.

Our equipment is modern and complete, facilities of the highest order, and our promptness all that could be desired. On these good points we base our past success.

We are grateful for your former favors and shall strive to merit a continuance of your appreciated patronage by rendering the best possible service.

In conclusion, we extend to you our best wishes for a Happy and Prosperous New Year.

## L. C. REISNER & CO.,

Manufacturing Jobbers, Importers and Exporters,  
Watch Materials, Tools and Supplies,

Jewelry Repairers for the Trade.

LANCASTER, PA.

OPEN YOUR CAMPAIGN  
 FOR THE COMING SEASONS WITH  
 A STOCK OF FAHYS RELIABLE  
 GOLD FILLED CASES

THE RALEIGH  
 THE CAMBRIDGE  
 THE OLYMPIA

Contain all the requisite features  
 of perfect gold filled watch cases

*Fahys*

Trade Mark

CATALOGUE ON APPLICATION  
**JOSEPH FAHYS & CO.**  
 ESTABLISHED 1857.  
 FAHYS BUILDING  
 NEW YORK



F596

THE CAMBRIDGE



F 523

THE OLYMPIA



THE RALEIGH



# The Last Shall be First.

# 1900

All conditions indicate that the last year of the century will be the best and most prosperous one. The retail jeweler can assure this beyond peradventure if he will carry in stock a complete line of

## The Standard Simmons Chains.

They are the best chains of the century, the acme of the chain-maker's art, and the 1900 line is better than ever. The same can be said of our

**CYRANO CHAINS, LOCKETS, SEALS AND  
MARLOWE BRACELETS.**

---

...AT JOBBERS...

---

## R. F. SIMMONS & CO.

New York Salesroom:  
9-13 MAIDEN LANE.

Factory and Main Office:

ATTLEBORO, MASS.

---

SALESMEN FOR 1900.

Western Representative, **LOUIS E. FAY.**

Eastern Representative, **GEORGE L. SWEET.**

New York Representative, **JOHN DRAKE.**

# "1835 R. WALLACE"

## *"The Stuart"*

WE HERE ILLUSTRATE  
OUR NEW PATTERN IN PLATED  
FLATWARE "THE STUART."

THIS PATTERN WAS ORIGINALLY INTENDED TO BE MADE ONLY IN A VERY FEW PIECES BUT ON ITS INTRODUCTION TO THE TRADE THE POPULAR FAVOR WITH WHICH IT WAS RECEIVED PROMPTED US TO MAKE THE PATTERN COMPLETE:

WE HAVE NOW READY FOR DELIVERY OVER FIFTY (50) DIFFERENT ARTICLES WHICH INCLUDE NEARLY ALL OF THE FANCY PIECES AND HOLLOW HANDLED TABLE CUTLERY

SEND FOR PAMPHLET NO. 12 ILLUSTRATING THIS PATTERN.

**R. WALLACE & SONS  
MFG. CO.**

FACTORIES,  
**WALLINGFORD  
CONN.**

BRANCHES:

226 FIFTH AVE. NEW YORK  
109 WABASH AVE. CHICAGO  
120 SUTTER ST. SAN FRANCISCO  
63 BASINGHALL ST. LONDON E.C.

SALAD SPOON.

SALAD FORK.

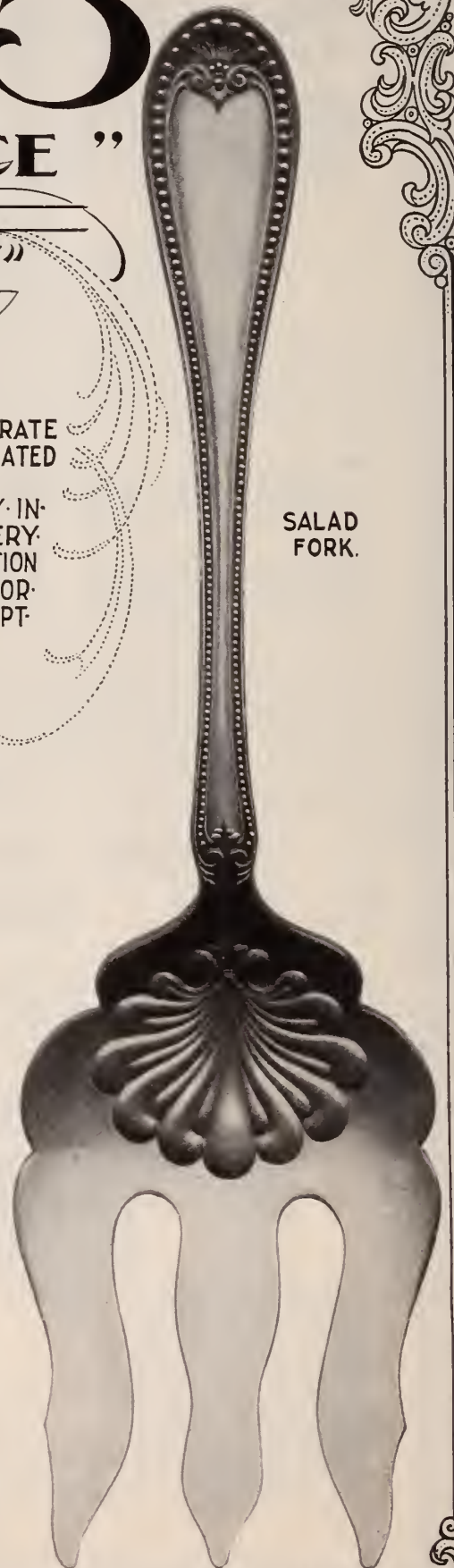
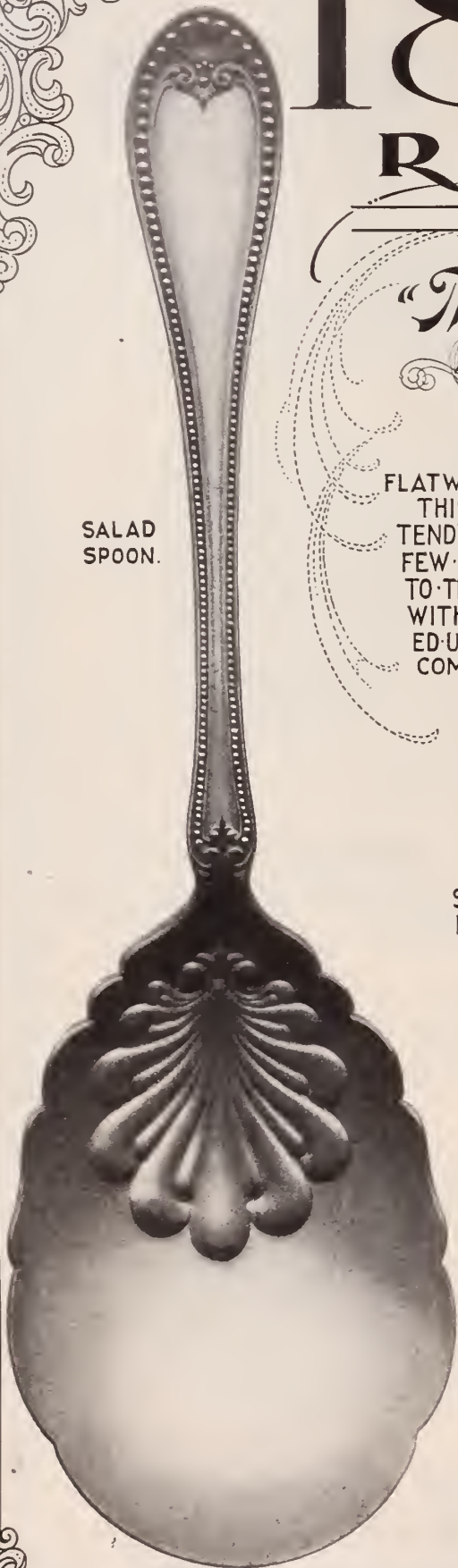

dle, group of figures "Charity" (?) at top, engraved bowl; 295, spoon, knotted handle, two figures at top; 296, spoon, knotted handle, figure of "Hope" at top, dated 1790; 297, spoon, knotted handle, two figures at top; 298, spoon, enriched and twisted handle, huntsman and dog at top, dated 1607, gilt; 299, spoon, old English, perforated bowl; 300, spoon, German, chased and ornamented handle, XVIIIth century.

This collection of spoons was gathered from a multitude of sources. Many were purchased from the various national sections of the Universal exhibitions of Paris, 1867, 1878, 1889, and of Vienna, 1873; from the bric-à-brac shops at London, Chester, Liverpool, Paris, Lille, Rouen, Blois, Brussels, Antwerp, Amsterdam, Hague, Harlem, Berlin, Frankfort, Nuremberg, Dusseldorf, Prague, etc., etc., and from the auction sales of private collections in different cities in Europe, such as those of Lord Londesborough, Earl of Craven, F. W. Fairholt, H. G. Bohn, P. Eudel, M. Charvet and others.

In concluding this series of interesting articles, it is well to say that all credit is due to J. H. Buck for his care and profundity of knowledge exercised and brought into requisition in the production of this work.

**Death of Sylvester Engle, Sr.**

HAZLETON, Pa., Jan. 9.—Sylvester Engle, Sr., jeweler, died at 9.02 last night, after an illness of several weeks. Mr. Engle was 73 years of age. Deceased was born in Brior Creek township, Columbia county, Oct. 27, 1827. When but a mere child his parents moved to Seybertsville, where he was reared and educated. When quite a young man he went to Wilkes-Barre, where he learned the jewelry and watchmaking trade.

In 1852 Mr. Engle took up his residence in this city, and immediately thereafter embarked in the business which brought him both competence and honor. Fortune seemed to smile upon him from the very beginning of his career, and when he was fairly on the road to success he united himself in marriage. Three children were born from the union, who, with a sorrowing widow, survive to mourn his loss. Two sisters and one brother also survive, viz.: Mrs. Henry Dryfoos, Mrs. Gideon Klinger and Stephen D. Engle, jeweler.

Mr. Engle was an honest, upright citizen, a conservative business man, esteemed and respected by all. Up to three years ago he enjoyed perfect health. At that time he sustained a paralytic stroke, and while not totally disabled, he began to sink gradually until a week ago, when he was forced to take to his bed. On Saturday evening he suffered another stroke, and since then he has been unconscious. He was a devoted member of the Presbyterian Church, and a member of the Hazleton Lodge of Free and Accepted Masons.

**Watch Club Decided to Be a Lottery in New Jersey.**

PATERSON, N. J., Jan. 10.—William W. Thompson, jeweler, Passaic, was found guilty in the Court of Quarter Sessions this afternoon of conducting a lottery in

organizing and carrying on a watch club scheme under which members secured prizes. The club had 100 members, and drawings were held each week, but many of the members allege that they did not receive the prizes, which were to be gold watches. There is a law forbidding selling tickets for lotteries, and Judge Barkalow directed the jury to bring in a verdict of guilty.

**H. H. Evertsen Becomes Manager of Dominick & Haff's Factory.**

MERIDEN, Conn., Jan. 8.—Henry H. Evertsen, of Wilcox & Evertsen, sterling department of the International Silver Co., will sever his connection with the above company this week. Mr. Evertsen intends

taking a few days' rest previous to his resuming the management of Dominick & Haff's factory, New York, with whom he, as foreman and superintendent, was connected 22 years.

The firm of Wilcox & Evertsen came to Meriden within a few years. A few weeks ago Mr. Wilcox left the International Silver Co. to accept a good offer. Reports are in circulation to the effect that the sterling silver department will be transferred to Wallingford, but from what is learned it is safe to say no such change will occur.

Ernest Eimer, Muskegon, Mich., has leased a large store at 107 W. Western Ave.

*1852-1900.*

*Forty-eight years* of business life,

*An unblemished reputation*

for products equal to the best,

*One standard—*

Sterling, 925-1000 fine;

*Experienced representatives,*

*A specialty of Tableware,*

salable the whole year through, are facts worthy your consideration in placing your orders for 1900.

*J. B. & S. M. Knowles Co.*



TRADE-MARK.  
Established 1852.  
Incorporated 1891.

*Silversmiths,*

*91 Sabin St., Providence, R.I.*

**DIAMONDS.**  
**Wm. S. Hedges & Co.,**  
 IMPORTERS OF  
**Diamonds and Precious Stones.**  
 DIAMOND JEWELRY.  
**170 Broadway, New York.**  
 26 Holborn Viaduct, London.

*Oppenheimer Bros. & Veith,*

*Importers and Cutters of*

*Diamonds*

*Dealers in*

*Watches,*

*Cor. Nassau and John Streets,*  
 (PRESCOTT BUILDING.)

*....New York....*

*Amsterdam,*  
*2 Tulp Straat.*

*London,*  
*45 Holborn Viaduct.*

**MOUNT & WOODHULL,** FORMERLY WITH LATE FIRM OF  
 RANDEL, BAREMORE & BILLINGS,  
 . . . IMPORTERS OF . . .

**Diamonds, Other Precious Stones, Pearls, Etc.,**  
**Makers of fine DIAMOND JEWELRY,**

26 MAIDEN LANE (SOUTHWEST CORNER NASSAU STREET), NEW YORK.

JOHN C. MOUNT.

ADDISON W. WOODHULL.

RUBIES.

SAPPHIRES.

**C. G. MALLIET & CO.,**

EMERALDS.

14 MAIDEN LANE, N. Y.

DIAMONDS.

## The Bowden Rings

ARE COMPLETE IN VARIETY, CORRECT  
 IN QUALITY AND PERFECT IN FINISH.  
 WE MAKE EVERY VARIETY OF FINGER  
 RINGS

**J. B. BOWDEN & Co.,**

1 MAIDEN LANE,

NEW YORK.

## ELSIE BEE'S FASHIONS.

A LADY'S RAMBLES AMONG THE JEWELERS.

Jewelry fashions continue as elaborate as ever, and in wearing rings it is not unusual for flashing gems to form a continuous line of light and color across the back of the hand, as every finger may be allowed its quota of gems, provided always that they are tastefully chosen with reference to one another.

Both plain polished ivory and plain bright silver are noticeably popular for the fittings of fine leather dressing bags.

Ebony brushes artistically mounted with silver find a large clientèle.

Cameo glass is beautifully employed in vases, pitchers, etc. A layer of violet or opal glass is superimposed upon white or a darker shade. Parts of the upper layer are then cut away, leaving the design in relief.

New single vest chains for men are very slender ones of gun metal or gold, in which brilliants, to the number of three or four, are set at regular distances apart.

Silver mounted cut glass lamps represent the acme of elegance and beauty.

One of the favorite ideas of English silversmiths is the reproduction of antique styles. The latest revival is that of quaint "James I." designs, of which an afternoon tea service furnishes a pretty example. No added ornament infringes on the delightfully curved contour of teapot, sugar basin and creamer in plain bright silver. Straight lines are shunned and even the edges of basin and creamer melt away in fascinating scallops, while the base of each of the pieces is supported by three oddly shaped short legs of a kind familiar to explorers among old silver.

A plain gold bracelet in bamboo pattern is quite novel.

Unique among men's rings is one consisting of a plate of pavé-set brilliants, which is curved to fit close to the finger and in the center of which is set a ruby cut to a long, narrow, marquise form.

A cat's eye, very high and round topped, set between two diamonds that are sunk in an antique carved ring of dull gold, is effective for a man's use.

A new long chain has the usual cabochons replaced by jade hearts of considerable size. Large cabochons of turquoise matrix are also very chic for these chains.

Exceedingly attractive are bright, lively shades of green noted in alligator and morocco leathers.

Among pretty leather goods brought out at the holidays is a folding case with oval silver frame for a photograph.

Staghorn furnishes handsome handles for chafing dishes.

ELSIE BEE.

**Precious Stones: London Market.**

HATTON GARDEN, London, Eng.,  
Jan. 5, 1900.

Stock taking is the order of the day, and accordingly very little business is reported. American buyers state that they are doing nothing just now, and beyond orders consequent on the discovery of gaps in stocks do not expect to be buyers for the next few weeks. The diamond market is particularly stagnant. The report as to the renewal of the contract between DeBeers and the syndicate is not discredited, although firms "in the know" decline information one way or the other. In any case it is only considered as a precautionary measure intended to keep the competing syndicate out of the market. The "production" of 1900 is very problematical. The impression I have repeatedly emphasized as to the non-working of the mines is at last authoritatively confirmed. The announcement was necessitated by the accruing of the usual interim dividend. I append the full cable from Kimberley: "MODDER RIVER, Dec. 27, 1899 (received by searchlight from Kimberley).—Board resolved pay no dividend this half year. Consider it advisable to husband resources we have, as there is no knowing when we may start work again. You must provide for debenture redemption and interest. Compliments season. All well.—DeBeers, Kimberley."

Continental markets are still in sympathy with London, more cutting factories have been closed, but no easement of prices is reported. Sellers do not push business to the extent of lowering quotations. Parcels at reasonable figures contain more than the average of poor stuff.

There are no specialties as regards American business in colored gems to report. Pearls, rubies and emeralds are mentioned in connection with home trade. The feature of the past year has been the growth in popularity of the turquoise.

R. F.

**H. H. Tammen and His Partner Both Shot.**

DENVER, Col., Jan. 13.—Frederick G. Bonfils and H. H. Tammen, proprietors of the *Evening Post*, the latter also being proprietor of the H. H. Tammen Curio Co., were both shot in their office at noon to-day by W. W. Anderson, a local attorney. Both were able to walk to carriages that carried them home. After the shooting Anderson walked out of the office unmolested, but later was arrested. It is understood that Anderson objected to something that had appeared in the *Post* and demanded retraction, and that Bonfils and Tammen both attempted to put him out of the office. Then he commenced to shoot. He claims he used his revolver in self-defense. Tammen and Bonfils say that Anderson walked into their office and commenced shooting without more ado. Anderson fired five shots. Tammen was shot in the shoulder, the bullet going into his breast. The physicians, from their hasty examinations, declared the wounds were not dangerous, although a closer examination may show them to be otherwise.

...ESTABLISHED 1841...

A. CARTER. C. E. HASTINGS. G. R. HOWE. W. T. CARTER. W. T. GOUGH.

**Carter, Hastings & Howe,**



MANUFACTURERS OF

**Gold Jewelry,**

9, 11, 13 MAIDEN LANE, NEW YORK.

FACTORY, NEWARK, N. J.

**Pearls**  
**Opals**

Importers and Cutters **GOODFRIEND BROS.,** Precious and Imitation Stones

9-13 Maiden Lane, N. Y. 174 Weybosset St., Providence, R. I. 10 Rue Cadet, Paris.

TELEPHONE, 662 CORTLANDT.

We have made a specialty of

**FINE FINGER RINGS**

for more than half a century.

**GEO. O. STREET & SONS,**

24 JOHN ST., NEW YORK.

... Established 1837 ...



**John F. Saunders,** Cutter and Importer of

**DIAMONDS** AND OTHER  
PRECIOUS STONES.

FINE PEARLS A SPECIALTY.

68 Nassau St., cor. John St., Sheldon Building, Room 16, NEW YORK.

## PEARLS.

## The Right Goods At the Right Time.

Fashion affects gems as it does dress.  
Certain gems are fashionable to-day;  
others to-morrow.

Our stock is always replete with the  
right goods at the right time.

Emeralds and Pearls at present.

## Alfred H. Smith & Co.,

182 Broadway, N. Y.

CHICAGO,  
103 State Street.

LONDON,  
21 Holborn Viaduct.

## DIAMONDS

And Other Precious Stones.

# NISSEN

*Ludwig Nissen.*



18 JOHN ST. NEW YORK

We carry the largest, finest and  
most complete line of Mounted  
Diamond Jewelry of any house in  
America.

## Tariff Decisions & Regulations.

### DUTY ON GLASS ARTICLES WITH METAL TOPS.

In a decision recently handed down by the Board of Classification of the United States General Appraisers the protest of C. F. Rumpp & Sons, Philadelphia, Pa., against the assessment by the Collector at Philadelphia, of 60 per cent upon cut glass bottles with metal tops imported by them June 1, 1898, was overruled. The articles named in the protest were invoiced as "flacons," and consist of cut glass perfumery and salts bottles of various sizes and shapes. Each article is provided with a glass stopper over which is screwed a nickel plated top. Duty was assessed on the articles at 60 per cent under Paragraph 100 of the present Tariff act for articles composed in chief value of cut glass. The importers claimed the goods to be dutiable at 45 per cent, under Paragraph 112 or Paragraph 193, as manufactures of glass or of metal not especially provided for. The Board find that *cut* glass and not glass simply, is the component part of chief value, and more specifically applies than do the paragraphs contended for by the importers. They decided that the articles were correctly assessed for duty and overruled the protest.

### DUTY ON GLASS AND METAL JEWELRY BOXES.

Among the decisions last week by the Board of Classification of the United States General Appraisers, was one overruling the protest of the Wm. Kock Importing Co. against an assessment at 60 per cent on jewelry boxes. The merchandise was composed of decorated glass and metal. The glass was found to be the component material of chief value. The importers contended that the boxes should not pay a higher rate of duty than 45 per cent, charged for wooden jewelry boxes. The Board, however, overruled their protest and sustained the assessment of 60 per cent.

### Developments in the Divorce Suit of Celia Wyman Against Her Husband.

COLORADO SPRINGS, Col., Jan. 12.—A divorce suit of Celia Wyman vs. Henry W. Wyman started some days ago is developing considerable interest in various ways. The suit filed about three weeks ago was afterwards withdrawn at the cost of the plaintiff. In this the plaintiff charged the defendant with cruelty and asked for suitable alimony, alleging that he was worth about \$50,000. The suit was dismissed for the purpose of filing another, but before the second suit was filed the defendant took a step toward his own defense. He filed with the county clerk a bill of sale of his jewelry and curio store and other real estate holdings to his son, Charles Wyman. It is expected that the plaintiff will petition to have the sale set aside pending the suit which she has filed.

A glass in the front window of 109½ Salem Ave., Roanoke, Va., occupied by Walter Guerrant as a repairing shop, was broken a few nights ago and seven watches stolen.



### STAPLE SILVERWARE.

Do not experiment with new or untried values in Silver-Plate. Wares bearing the trade-marks here shown have been sold for half a century, and can safely be looked upon as staple. Past reputation has made them a reliable and salable quality, and will continue to make them brands sought after by the consumer.

To stimulate the sale they have been largely advertised, and in the future will be kept before the public by attractive announcements in all leading periodicals, ensuring an ever-increasing demand. The dealer will be materially benefited by having a good assortment of these goods to show possible customers.

TRADE-MARK  
ON  
TEA SETS.  
ETC.  
MADE AND  
GUARANTEED BY



International Silver Co., Successor to  
**MERIDEN BRITANNIA CO., - MERIDEN, CONN.**  
New York. Chicago. San Francisco.

TRADE-MARK  
ON  
SPOONS,  
ETC.

"1847  
Rogers  
Bros."

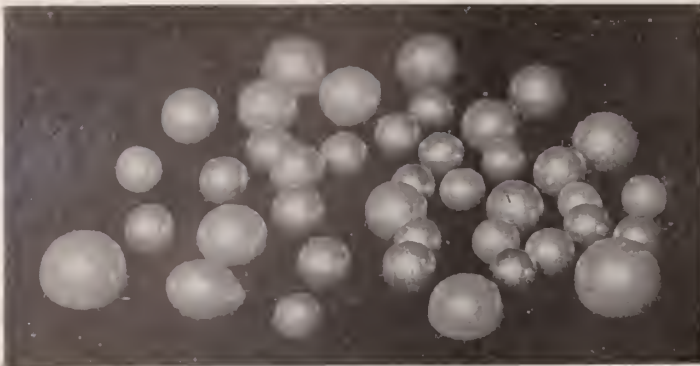

**"The Pearl House."**

We have no salesmen; call or write.

**EISENMANN BROS.,**

PARIS, 3 Rue St. Georges.

21 & 23 MAIDEN LANE, NEW YORK.

**MATHEWS & PRIOR,**

DESIGNERS AND MAKERS OF

**Sterling Silverware**

TO THE LEGITIMATE

**JEWELRY TRADE ONLY,**



245-247 West 28th Street,  
New York City.

**PATEK, PHILIPPE & CO.,** GENEVA, SWITZERLAND,

MAKERS IN THE HIGHEST QUALITY OF

**Fine, Plain, Complicated  
And Decorated Watches**

IN 15 DIFFERENT SIZES.

INTERCHANGEABLE PARTS.

NEW YORK OFFICE, 68 NASSAU ST.

ALFRED G. STEIN, Representative.

**Stern Bros. & Co.,**

Cutters of . . .

MANUFACTURERS OF

**DIAMONDS, Gold Rings and Thimbles,**

68 NASSAU STREET, NEW YORK.

RING FACTORY, 33-43 GOLD STREET, NEW YORK.

LONDON OFFICE, 29 ELY PLACE.

DIAMOND-CUTTING WORKS, 142-146 W. 14TH ST., NEW YORK. CHICAGO OFFICE, 149 STATE ST.

**BONNER & CO.,**

Manufacturers of

**FINE DIAMOND MOUNTINGS,**

57 MAIDEN LANE, . . . NEW YORK.

**Death of Philip Bissinger.**

Philip Bissinger, one of the oldest members of the precious stone trade of this country and one of the earliest importers of jewelry into this country, passed away early Wednesday morning at his home,



THE LATE PHILIP BISSINGER.

19 E. 34th St., New York. Death was due to heart failure, which followed a complication of diseases. Though failing for some time Mr. Bissinger was apparently vigorous and did not appear to be seriously ill until about nine days before his death.

There are few men in the entire jewelry trade of this country who have passed a longer or more successful career than did the deceased, and among the German residents of New York no man stood higher or was more thoroughly respected than was he. Mr. Bissinger was born on July 2, 1827, in Flehingen, Grand Duchy of Baden. After receiving his education in his native town he commenced his business career at the age of 14 years, when he entered the jewelry house of Theodor Lenz & Co., Pforzheim. Although then but a boy, during his career with this house he manifested the skill and energy which in later years, when more thoroughly developed, attained for him the many successes for which his career was notable.

His aptitude and firmness of character so impressed his first employer that when he had been with him seven years the entire management of the establishment came under his control while his employer visited America. Although he had attained a position of responsibility with Mr. Lenz he decided to leave this firm in order to gratify his desire to travel, and, therefore, accepted a position with Wm. Kaempff & Co., the largest jewelry manufacturers of Pforzheim, who were then desirous of es-

**JAMES KAHN'S SONS,**

PARIS: 7 RUE CADET.

IMPORTERS AND CUTTERS OF DIAMONDS,

Amsterdam, 2 Tulp Straat.

12, 14 & 16 John St., New York.



establishing a branch in America. This task Mr. Bissinger undertook for them, and he arrived in the United States Dec. 16, 1849. From the time he established their branch here Mr. Bissinger built up the business rapidly, and four years later had become so well known to the trade of the United States that he decided to go into business on his own account.

In 1853 Mr. Bissinger commenced business at 13 John St., and among his first successes was that which followed his introduction of Bohemian garnet jewelry and blue enameled goods. For a while he was the agent of Michael Goldschmid's Sohnes, of Prague, the makers of these lines, which he later gave up to confine himself exclusively to the importation of diamonds and precious stones. For nearly 50 years Mr. Bissinger stood prominent among the leading precious stone importers of New York, and for many years had an office at 20 John St.

Although he gave much time to the building up of his precious stone business, he, nevertheless, found time to take part in many enterprises outside the trade. Among his principal work in this respect and probably the one in which he took the most interest were the founding and developing of the German Savings Bank of New York. This bank Mr. Bissinger with a few friends started a few years after he arrived in this country, and after much opposition succeeded in obtaining a charter in 1859. It was greatly through his work and influence that the bank grew very rapidly, and in 1864, when it had obtained prominence as one of the leading institutions of its kind, Mr. Bissinger accepted the presidency of the bank, a position which he held up to the time of his death. Various other institutions, however, received his attention, and he was prominent as one of the members of the Germania Life Insurance Co., the Germania Fire Insurance Co., the Manhattan Life Insurance Co., the German-American Bank, the German Hospital and Dispensary and a number of similar institutions. He was a member of the Chamber of Commerce, Metropolitan Museum of Art, Museum of Natural History, New York Ophthalmic and Aural Institution, Deutscher Verein, German Hospital Society, the Charity Organization Society, Isabella Home Society, St. John's Guild and a host of other business and charitable associations. Besides these he was a member of several clubs, among them the Liederkrantz, the Down-Town Association and the New York Club. Among the positions of prominence which Mr. Bissinger held was as member of the Emigration Commission, and for his services in behalf of humanity, shown while on this board, Emperor William I. of Germany conferred on him the Order of the Crown of the third class.

The deceased never married and had no relatives or kin in this country. He is survived by brothers and sisters in Germany. The funeral services were held Saturday at 1 o'clock P. M. from the Church of the Holy Trinity, 21st St., between Fifth and Sixth Aves. They were largely attended.

At a special meeting of the board of trustees of the German Savings Bank, held Saturday, upon announcement of the

death of Philip Bissinger, president of the institution, the following preamble and resolutions were unanimously adopted:

The trustees of the German Savings Bank in the city of New York have received with deep sorrow the announcement of the death of their associate and friend, the president of this bank, Mr. Philip Bissinger. He was one of the incorporators of the bank, and for over 35 years its honored president. By his force of character, sterling integrity and sound judgment in the direction of its affairs he won the confidence of all having relations with the bank, as evidenced by the steady growth of its resources and in the esteem and confidence of the public.

We bow in sadness to our loss, and direct that this minute be entered on the records of the bank, with whose history his name will forever be inseparably connected.

*Resolved*, That this Board attend the funeral services in a body, that the flag of the bank be daily displayed at half-mast until the day of the funeral; that these resolutions be printed in the press of the city, and that an engrossed copy be

sent to the family of Mr. Bissinger as an evidence of our sympathy.

E. Willard Jones, trustee in bankruptcy of the estate of John Wagner, Utica, N. Y., will sell at public auction to the highest bidder, at the store, 116 Sunset Ave., Utica, N. Y., Jan. 19, at 2 o'clock P. M., the following property, viz.: A quantity of optical goods, lenses and frames.

Jacob Mednikow, jeweler, Milwaukee, Wis., who was held up at his place of business, 160 Reed St., on Thanksgiving night two years ago, seems to be a prey to highwaymen. About 2 o'clock A. M., Jan. 7, while passing the corner of Third and Fowler Sts., he says, two young men stopped him, and after threatening him with coupling pins, they searched his pockets and obtained \$9.

## PEARLS.

While Diamonds remain pre-eminently the most popular of all the precious stones, Pearls are growing in favor constantly with people of quiet and refined tastes.

We have them unmounted in all sizes and a very complete and attractive stock of mounted goods, either alone or in combination with diamonds.

**HAYDEN W. WHEELER & Co.,**

**TWO MAIDEN LANE, N. Y.**

**50 HOLBORN VIADUCT, LONDON, ENGLAND.**

## Silversmiths Have a Banquet.

The Many Heads of Departments of the Gorham Mfg. Co. Hold an Enjoyable Session.

PROVIDENCE, R. I., Jan. 11.—A most enjoyable affair was held in the Casino at the works of the Gorham Mfg. Co., Elmwood, last night. It was a banquet of the heads of the various departments at the Gorham works and was tendered by the company to those who have so long been in their employ, and who have won for themselves recognition in the departments over which they preside. There were over 60 persons in attendance.

The Casino was handsomely decorated for the occasion, flags, potted plants, cut flowers and tropical greens predominating in the decorations, while four long tables were required for the accommodation of the guests. These tables were lighted by candelabra and beautified by floral pieces of unique design. So far as was possible, those present were seated according to the length of time that they had been in the employ of the firm. For instance, the head table was occupied by the men who became associated with the concern some time during the '60's or before, while at the other three tables were the '70's, '80's and '90's.

J. F. P. Lawton, secretary and assistant treasurer of the company, was to have occupied the position of honor at the head of the first table, but owing to illness was unable to be present. Seated at this table were the following, the date when they began their work for the firm being given:

F. C. Lawton, 1881; Mr. Codman, 1891; J. Baker, Jr., 1865; Mr. Jordan, 1860; Mr. Young, 1859; Mr. Aldrich, 1865; Mr. Bushnell, 1850; Mr. Dean, 1850; Mr. Salt, 1862; Mr. Bogle, 1869; W. Whipp, 1868; Mr. Burt, 1866; Mr. Peck, 1865; Mr. Shurrocks, 1863; W. Hughes, 1865; Mr. Burgess, 1865; Mr. Thurber, 1872; Mr. Darling, 1868; Mr. Lee, 1865; Mr. Tucker, 1864; Mr. Pike, 1866; Mr. Stevens, 1860.

At the first table at the right of the table of honor were: Mr. Straker, 1874; Mr. Rees, 1872; Mr. Robinson, 1875; Mr. Wightman, 1877; W. Smith, 1873; Mr. Seagrave, 1869; Mr. Anthony, 1880; Mr. Gardiner, 1880; Mr. Webster, 1871; Mr. Fulford, 1876; Mr. Mason, 1874; Mr. Phillips, 1871. At the table in the center were: Mr. Day, 1880; Mr. Brown, 1884; Mr. Lyman, 1888; Mr. Davenport, 1885; Mr. Pender, 1886; T. Hughes, 1884; J. Whipp, 1888; G. Baker, 1882; Mr. Miller, 1890; Mr. Nock, 1885; Mr. Rhodes, 1885; Mr. Peters, 1889; V. Smith, 1891; Mr. Swain, 1892; Mr. Allebaugh, 1891. At the third table were: Mr. Hansen, 1896; Mr. Weatherhead, 1895; Mr. Curley, 1892; Mr. Johnson, 1891; Mr. Champney, 1898; Mr. Crawford, 1899; Mr. Richter, 1895; Mr. Sylvia, 1895; R. W. Higgins, 1895; Mr. Huntington, 1899; Mr. Needham, 1897; Mr. Briggs, 1895.

Dinner was served by Tillinghast, the discussion of an elaborate menu being made additionally pleasurable by selections by harpist Frank Raia and by Joseph E. Pettine, mandolinist. Then came the post-prandial exercises, over which superintendent F. C. Lawton presided in a happy manner. He presented Henry C. Bushnell, who gave a brief sketch of the first efforts at spoon-making. Mr. Bushnell spoke of the early days at the old factory of Gorham. Webster & Price, on Steeple St., contrasting it with the present modern plant of the Gorham company. He alluded to the fact that at that time the term "horse power" was used advisedly, for the machinery in the

factory found its motive power in a single horse, which operated a turnstile and kept the wheels in the shop moving.

Joseph Baker, Jr., gave some interesting reminiscences of the apprenticeship days of 1865 and 1866, and was followed by master mechanic J. M. Bogle. Mr. Bogle spoke of the contrast between the Steeple St. plant and the present one in Elmwood, giving some facts and figures that were of interest to all present. Designer W. C. Codman spoke of the pleasure he felt at being present and referred briefly to the work of the company. Superintendent F. C. Lawton told of the organization of the executive force and alluded to the good derived from gatherings of this nature since they assisted materially in increasing the pleasant relations which should exist between the heads of the various departments and with those in authority.

At the conclusion of the banquet flowers were sent to J. F. P. Lawton, to Joseph Baker, a retired foreman; to Mr. Pender, who was unable to be present, and to president Edward Holbrook, who happened to be in the city, as an evidence that they were remembered, though absent. The entire affair was a pronounced social success.

### Nominees for Official Positions in the Philadelphia Jewelers' Club.

PHILADELPHIA, Pa., Jan. 10.—At the regular monthly meeting of the Philadelphia Jewelers' Club, held last night, nominations were made for officers to be elected to serve throughout the current year. J. Warner Hutchins, president of the club, was unanimously nominated to succeed himself. The nominees for vice-president are Charles F. Duffy, of Enos Richardson & Co., New York; Archie Rutherford, of H. A. Kirby Co., New York, and John W. Taylor, of Krentz & Co., Newark, N. J. Wm. F. Parry, Jr., of the S. S. White Co., was the only nominee for treasurer. Wm. F. Quinn, of H. Muhr's Sons, and James W. Barry, Jr., with J. D. Hughes, were nominated for secretary. Mr. Barry has been secretary of the club ever since its organization, but for the past six months the duties of the office have been performed by Mr. Quinn. It is presumed the latter will be elected to fill the place. There are five members of the board of governors to be elected. The nominees are L. P. White, Wm. P. Sackett, Wm. H. Long, A. G. Lee, Joseph H. Kelley, F. W. Stanborough, Harry C. Larter, George W. Read, Frederick M. Simons, Newton B. Elting, John Battin, A. B. Midlan, L. B. Hall and Wm. Linker.

The following were elected members of the club: F. W. Trewin, Keystone Watch Case Co.; Edward Rutchesell, Hamilton & Co., and Hardy Bush, Cartois, Bush & Garriques. The annual election and meeting will be held Feb. 6.

The building occupied by W. H. Mansfield, jeweler, Northfield, Vt., caught fire about 10 o'clock the evening of Jan. 1, and burned to the ground. Mr. Mansfield's loss is about \$1,000, partially insured. The fire was first discovered in the basement of the building, but the cause of its starting is unknown.

PRICES ARE STIFFENING UP ALL AROUND.

QUOTATIONS ON WATCHES SHOULD BE ENDORSED:

PRICES OR DISCOUNTS SUBJECT TO CHANGE WITHOUT NOTICE.

TO ORDER ADVANTAGEOUSLY, 'TWERE WELL TO ORDER QUICKLY.

"A WORD TO THE WISE IS SUFFICIENT."

WE ARE THE LARGEST DISTRIBUTORS OF

**Dueber-Hampden Watches**

IN AMERICA.

RAILROAD WATCHES A SPECIALTY.



*John H. Furwood & Co.*  
Watches. Chains. Diamonds. Jewelry.

No. 3 MAIDEN LANE, NEW YORK.

# THE DUEBER HERALD

THE ADVOCATE OF HONEST BUSINESS METHODS.  
 DEVOTED TO THE RETAIL JEWELRY TRADE.

Vol. I.

CANTON, OHIO, JANUARY, 1900.

No. 12.

## THE BEGINNING.

What is worth doing, is worth doing well.

\* \* \*

To do well, if you do not begin well, is difficult; if, indeed, not impossible.

\* \* \*

You cannot begin the New Year better—in a business way, that is—than by determining to investigate the claims and assertions made by the management of the Dueber-Hampden Works.

\* \* \*

Do it; and do it well.

## CAUSE AND EFFECT.

The management of the Dueber-Hampden Works have for years, persistently and assiduously, opposed every measure, policy, coalition, "new invention" or device, etc., that tended to work harm to the interests of the watch dealers and watch purchasers of the country,

AND

every measure, policy, coalition, "new invention" or device, etc., so opposed, has proved to be, as the management of the Dueber-Hampden Works predicted, a **FAILURE!**

### "THE BEST."

Charleston, N. C.

I am carrying a 17-jewel Hampden watch. It is the best watch in the country.

C. S. MORRISON, Conductor,  
 Richmond & Danville Railroad.

## THE MATTER OF DESCRIPTION.

You may describe a horse as being decked all over with gilt tassels, but if it cannot **trot**, the bombastic description of its tassels won't make it win a race.

You may describe a watch as being fitted with as many frills as you please; you may make the description as bombastic as you please; but neither frills nor bombast will make the watch keep time.

There is nobody in the offices of the Dueber-Hampden Works gifted with sufficient brilliancy to create for the Dueber-Hampden Watchessuch highfalutin, mystifying descriptions as are employed for other watches we know of.

The Dueber-Hampden product is: Closely running watches—the closest-running watches ever produced; they're stylish, they're modern, they're "The Best." And that's all the description that goes with them.

Most important: The description fits the goods!

## HOW DUEBER GOODS ARE SOLD.

The Dueber-Hampden Works sell their entire product only through the wholesale and retail watch dealers of the United States, and they do not solicit nor accept orders from Department Stores, Farmers, Supply Houses, etc.

## "FOR EXAMPLE."

"We defy competition."

\* \* \*

A strong assertion to make, isn't it? But who can find fault with it if it's substantiated?

\* \* \*

The Dueber-Hampden Works assert it. Their product substantiates it.

\* \* \*

Their three new 12-size watches and "The Four Hundred," for ladies, for example.

## THE REASON.

The three new 12-size movements of the Hampden Watch Works, the "Dueber Grand," 17 jewels; the "Dueber Watch Co.," 17 jewels, and the "John Hancock," 21 jewels, are sold **only** in the 14 and 18 karat solid-gold and 14-karat gold-filled watch cases of the Dueber Watch Case Manufacturing Co., in order to protect the retailer, and prevent the sale of these movements in, for instance, so-called "40-dwt. solid-gold cases," containing 20 dwts. of lead.

### "THE BEST" AGAIN.

Central City, Ky.

I am wearing a 17-jewel Hampden watch to run an engine on the N. N. & N. V. R. R. It is the best I ever saw.

HENRY FRISS.

# HEADQUARTERS

For....  
Everything

Used by  
Jewelers.

SEND  
FOR  
PRICE-  
LIST.

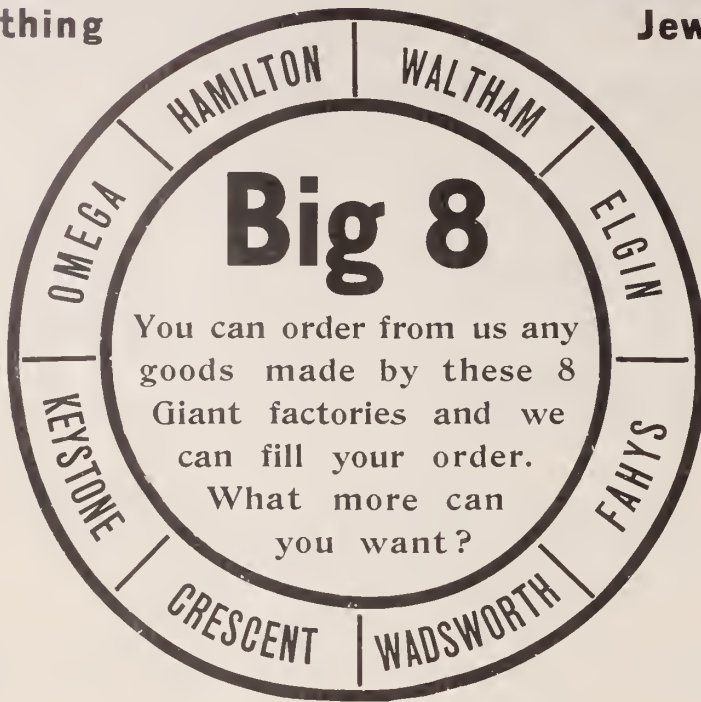

THIS  
WILL BE  
A  
GOOD  
WATCH  
YEAR.

**Cross & Beguelin, 17 Maiden Lane, N.Y.**



## Our New... Jewel Case



has been pronounced  
by competent judges  
the best in size, shape,  
workmanship and fit-  
ting, in the market.

**Roy Watch Case Co.,**

Makers of SOLID GOLD CASES,

21 Maiden Lane,

New York.



TRADE-MARK REGISTERED.

### Death of One of the Founders of New Haven's Clock Industry.

NEW HAVEN, Conn., Jan. 11.—The death occurred yesterday of Paschal Converse, one of New Haven's oldest and most respected citizens. Mr. Converse was 89 years of age. Notwithstanding his advanced age Mr. Converse was able to get around quite actively.

Mr. Converse was born in Bristol, but his life covers a large period in the history of clock making in New Haven, with which he was prominently identified for half a century. He left Bristol and came to New Haven with the late Chauncey Jerome and the late Hiram Camp for the purpose of forming a clock company here. The company were known as the Jerome Clock Co., after the founder and first president, Chauncey Jerome, and afterwards were incorporated as the New Haven Clock Co.

Mr. Converse was a cabinet maker by trade, and he was given the contract for all the wood working and sawing of the company at the new shop in New Haven, retaining that place for more than 40 years. Deceased leaves three children, two sons and a daughter. One son, Frederick L. Converse, was formerly a manufacturer of clocks in a factory on Artizan St., and later traveled for the Seth Thomas Clock Co.

### Jeweler Froude's Foresight Saves Him from Robbery.

PATERSON, N. J., Jan. 12.—About 7.30 o'clock a few nights ago two well dressed men called at the residence of Anton Ehmann, cigar manufacturer, in Passaic, and asked if Mr. Hancock lived there. Mrs. Ehmann answered, giving her name. A little later two men called at William B. Froude's jewelry store and told Mr. Froude, who was alone in the place, that Mrs. Ehmann wanted him to call and bring several fine diamonds in order that she might make a selection. Mr. Froude said he would go later, and upon leaving the store took a half dozen diamonds in his pocket. On the way to Mrs. Ehmann's the thought struck him that all might not be right, and he stopped at the police station. Two patrolmen followed him all the way, but he was not molested, and, as he partly expected, Mrs. Ehmann told him she wanted no diamonds. A comparison of notes showed that the men who called at the Ehmann home and those who delivered the decoy message to Mr. Froude were the same. Their evident intention was to waylay and rob him of the diamonds.

Garibaldi & Bruns, Charlotte, N. C., have been appointed inspectors of watches for the entire Seaboard Air Line system.

A few days ago ex-Mayor Fields, of Northampton, Mass., received a letter from a Boston jewelry house, stating that a firm in Northampton styling itself Solomon Myers & Co., had secured goods from them, and asking him to investigate. He went to the store in the Sterling block with a deputy sheriff, but found that the members of the firm had disappeared as mysteriously as they came. Since then nothing has been heard of them or their whereabouts.

**The League's 23d Annual.**

**An interesting Session of This Important Organization.**

MASONIC HALL,  
New York, Jan. 16.

The Jewelers' League of New York tonight held their 23d annual meeting in this hall. Prior to the meeting, according to a custom followed for many years, a number of the officers, executive committee, members and their friends sat down to a banquet at Mouquin's Knickerbocker Cottage, 28th St. and Sixth Ave.

The meeting at the hall was opened by 3d Vice-President Bowden in the absence of President Hayes, owing to an engagement with a dentist. The reading of the minutes of the last meeting was on vote dispensed with and President Hayes's address was read by Attorney Crook:

**ADDRESS OF PRESIDENT HAYES.**

*Fellow Members of the League:*

As we enter our twenty-third year, allow me to congratulate you upon the excellent condition of our association. You know it is a company of associates, united in a community of interests, than which none can be of greater import. The thought of one's self is natural, but self is a low view of an ideal that should be high. In our allied interests the one idea is to care for the welfare of those who come after us. That they shall not fall upon the cold charity of the world is the prompting of earnest desire for the comfort and solace which will come to those for whom our thoughtfulness and love have made sacrifices to assist and cheer. One of the strong features of the League is the fact of the large benefits which careful attention to its affairs and strict economy of management bring to our beneficiaries. The field is not circumscribed, as in our past years, for with three doors of admission now open with equally wide portals for all, we offer equitable and proportionate benefits to those who come to our household. The man of moderate means can take advantage of our prosperity equally with one of larger resources. There exists no feeling of exclusiveness which formerly was unadvisedly attributed to us when but the one class existed. Conditions of life change in the course of revolving years, and if unfortunate circumstances render it imperative for any one of us to curtail expenses, the two doors of Classes B and C are open and can be entered by such as deem it prudent or necessary to pay a smaller assessment, yet with all contingent advantages. Cannot each and all of us make the slight effort during the coming year to impress upon a relative or friend the great advantages to be gained by joining our institution which offers so much to our heirs? The communal sentiment is a strong one, adding strength to the advantageous financial features, and it may well be urged upon our friends and neighbors as being worthy of further thought.

During the year the Philadelphia branch of the League has been conducted with additional life and interest, giving an impetus to the consideration and welfare of interests to our mutual advantage. Cannot and will not other cities copy this example, by giving a small amount of time and thought to so worthy an effort? It is needless for me to more than call your attention to the report of our treasurer as an exhibit of our excellent and growing financial status. The multiplied and varied demands upon our office work are certainly met by most comprehensive yet simple methods, and I venture to assert that completeness of details surrounded by the most conservative prudence are not surpassed in any institution of a nature similar to ours. To the treasurer, as well as to his courteous and competent assistants, are due our warmest consideration.

Pleasure, rather than propriety, spontaneously prompts me to refer to the labors of the executive committee. Are you aware of their devotion, care and attention to every interest of the League? Do you appreciate the time and thought given to our welfare? Throughout the entire existence of the League we point with pride to the high character of the men who have composed these committees, and the present members are compeers of them all. It is an honor to be surrounded by and have the benefit of the counsel of such able and worthy business men. All praise to these busiest

of men, who ignore their own convenience and cares for the high call of duty and loyalty to our interests.

The past year has been one of prosperity and substantiality to the League. Assessments have been most promptly and generally met. The average age of the membership has been lowered, while a very slight effort by all our members would further reduce the average and serve to place our institution on a still higher plane of prominence and certainty.

And now, gentlemen, I congratulate you upon the success of the past year with best wishes for the new, hoping and believing that the closing year of the nineteenth century will be the brightest in your lives and a precursor of a brilliant future for our cherished League.

After the usual applause which followed this address had subsided, it was spread upon the minutes and was ordered printed and sent to all members. The treasurer's report was next in order, but this, with the report of the examining finance committee, having already been printed and in the hands of all members, the reading of it was dispensed with. The reports are here printed in full:

**ANNUAL REPORT OF THE TREASURER.**

Cash on hand Jan. 1, 1899..... \$46,557 91

**RECEIPTS.**

Interest from Investments..... \$7,057 98  
From First Assessments..... 58 63  
Quarterly Dues for Reserve Fund ..... 8,449 00  
Advance Payments ..... 857 75  
Initiation Fees ..... 108 00  
Quarterly Dues for Expense Fund ..... 8,320 00  
Money Returned, Expenses Sundries ..... 53 00  
Rents, Real Estate..... 1,017 70  
Rebate on Taxes ..... 13  
Collection on Checks ..... 52 08  
Mortgage of Geo. Foster..... 6,000 00  
Sale of Real Estate..... 9,821 10

Assessments as follows:  
Nos. 387 to 389 ..... \$9 00  
" 399 ..... 1 50  
" 400 & 401 ..... 4 00  
" 402 to 405 ..... 59 50  
" 406 to 408 ..... 1,315 25  
" 409 & 410 ..... 6,672 00  
" 411 to 413 ..... 17,069 50  
" 414 to 416 ..... 14,166 01  
" 417 & 418 ..... 11,346 25  
" 419 ..... 5,668 75  
" 420 to 422 ..... 16,943 00  
" 423 to 425 ..... 16,761 50  
" 426 to 428 ..... 16,805 25  
" 429 ..... 5,582 50  
" 430 & 431 ..... 11,132 13  
" 432 & 433 ..... 11,156 26  
" 434 ..... 5,272 01  
" 435 to 437 ..... 6,073 75 146,038 16 187,833 53

\$234,391 44

**DISBURSEMENTS.**

For Purchase of Securities:  
5,000 Hocking Valley R'y Bonds... \$5,143 75  
5,000 Northern Pacific R'y Bonds... 5,106 25  
10,000 Union Pacific R'y Bonds ..... 10,397 50  
10,000 Baltimore & O. R'y Bonds ..... 9,758 88  
Bond and Mortgage... 15,305 08 \$45,711 46

For Salary of Secretary and Treasurer ... \$2,800 00  
Salaries of Office Employees ..... 1,902 00  
Expense Sundries.... 980 74  
Postage ..... 868 11  
Commission for New Members ..... 518 24  
Traveling Expenses.. 1,300 00  
Books, Printing and Stationery ..... 823 91  
Auditors' Fees..... 190 00  
Legal Expenses .... 250 00  
Rent ..... 300 00  
Medical Fees ..... 42 50  
Collection on Checks ..... 39 54 10,015 04

Overpaid by W. C. Cooke, Ass't 393 to 395 \$4 50  
Overpaid by W. Friederich, Dec'd Ass't 432 & 433 ..... 5 00  
Overpaid by W. Friederich, Dec'd 4th Qly. Dues ..... 1 00 10 50  
Amount of Advance Payment from members applied to the payments of assessments due from them 777 25

Taxes ..... 1,030 43  
Improvements on Real Estate ..... 5,537 12  
\$63,081 80 \$234,391 44

Payments to the beneficiaries of the following members deceased:  
Section A.

T. Rohner ..... \$5,000  
R. J. Walton..... 5,000  
F. Meerbott ..... 5,000  
\*E. Francis ..... 4,500  
J. Dickman ..... 5,000  
N. Taylor ..... 5,000  
L. Stern ..... 5,000  
O. Zamon ..... 5,000  
C. Aughinbaugh ..... 5,000  
J. Eichler ..... 5,000  
F. X. Becker..... 5,000  
J. Kasper ..... 5,000  
W. Isbell ..... 5,000  
J. Seeley ..... 5,000  
I. Cole ..... 5,000  
A. Franz ..... 5,000  
C. Livermore ..... 5,000  
W. Becker ..... 5,000  
W. D. Dreher ..... 5,000  
A. Schanz ..... 5,000  
A. Cooley ..... 5,000  
A. Yartzky ..... 5,000  
F. Kroeter ..... 5,000  
C. H. Sadler ..... 5,000  
G. Kunz ..... 5,000  
W. Smith ..... 5,000

Section B.  
G. J. Leach ..... 2,500 132,000 195,081 80

\*\$500 Paid on account Nov. 16, 1898.  
Cash on hand Dec. 30, 1899 ..... \$39,309 64

**ASSETS.**

January 1, 1900. Market Value Dec. 26, '99.  
New York City Bonds ..... \$56,540 00  
Brooklyn Bonds ..... 48,112 50  
Union Pacific Railway Bonds..... 15,525 00  
Northern Pacific Railway Bonds..... 10,250 00  
Atchinson, Topeka & Santa Fe R'y Bds. 4,850 00  
Missouri, Kansas & Texas R'y Bds... 4,450 00  
Missouri, Kansas & Eastern R'y Bds.. 5,150 00  
Burlington & Cedar Rapids R'y Bds... 5,300 00  
Hocking Valley Railway Bonds..... 5,000 00  
Baltimore & Ohio Railway Bonds..... 9,758 88  
Bond and Mortgage ..... 7,000 00  
Real Estate ..... 35,903 77  
Cash on deposit:  
Union Trust Co..... \$18,945 85  
Chatham National Bank... 20,277 63  
In Office ..... 77 11 39,309 64

\$247,149 79

**LIABILITIES.**

Held in Trust for Members to pay assessments to be levied hereafter ..... \$215 50  
Death losses in process of adjustment:  
Death of R. Klarenaar—Collected, awaiting completion of proofs.. 5,000 00  
Death of J. H. Higgins—Collected, awaiting completion of proofs.. 5,000 00  
Death of Wm. Downey—Collected awaiting completion of proofs.. 5,000 00  
Death of Wm. Friederich—December assessments in process of collection ..... 2,021 75  
Death of Nils Rose—December assessments in process of collection ..... 2,026 25  
Death of A. Weinberg—December assessments in process of collection ..... 2,025 75 21,289 25

\$225,860 54

L. STEVENS, JR., Treas.  
NEW YORK, Jan. 4, 1900.

The undersigned have examined the books and accounts of the Jewelers' League, and find them correctly set forth in the Treasurer's Report. They also find that the bonds as specified are deposited in the vaults of the National Safe Deposit Co.  
HENRY UNTERMEYER,  
W. J. DURFEY,  
E. R. CRIPPEN,  
Examining Finance Committee.

After this Chairman Van Deventer, of the executive committee, read his report, which, as usual, was enthusiastically received.

**REPORT OF EXECUTIVE COMMITTEE.**

Mr. President and Members of the Jewelers' League:

We come to the celebration of our twenty-third anniversary, congratulating one another on the good and grand work that the League has accomplished, not only in the year 1899, but in all the years of our existence.

The year just closed has been one of unusual business prosperity and strongly in contrast with the experience of some of the preceding years. The outlook for the present year is exceedingly

encouraging and bids fair to outstrip the past. We hope that such may be the experience of every one of our members. Under such circumstances of prosperity in the trade it becomes an urgent duty of the members of the society to increase its membership. Those of us who are moving on past 45 should bring in our sons, nephews, employers, their clerks, and young men their companions, so that our ranks may be filled up and all of us have the satisfaction of knowing that our beneficiaries will receive the full amount permitted under our constitution.

During the past year Section "C" was formed, but we have not had the success in that line that was expected. Sections "A," "B," and "C" form scope enough for the wants of all, and there only lacks the effort on your part to fill these sections up with your friends.

We hear in these times a great deal about the open door and the expansion policy. It is a good thing for you to think about in the League. Our door is wide open, in fact there are three doors, "A," "B," and "C." Bring them in through any one of these gates, only bring them in; once inside we will show that we can expand even to the ends of the earth.

During 1899 we have received 36 members. During 1899 we have assessed for the death of 26 members in Section "A," and one member in Section "B;" none in Section "C."

We have paid out to beneficiaries in 1899 the sum of \$132,000.00

Our membership Jan. 1, 1900, is:

Section "A".....	1937	members.
" " "B".....	161	" "
" " "C".....	11	" "

Total ..... 2,109 "

We have paid to beneficiaries during our existence the vast sum of \$2,138,235.85.

We have a reserve fund over and above all liabilities of \$225,800.54.

Now once more we exhort you to bring in new members. It is the only feature of our brotherhood that is not up to the desired point, and it is the only place where danger lurks.

Respectfully submitted.

GEO. M. VAN DEVENTER,  
Chairman of Executive Committee.

This report was received, and a rising vote of thanks was given to the committee.

Under the head of new business, the proposed new amendment to the constitution, providing for an increase in the advisory members up to 18, was then taken up. Mr. Lissauer advocated the adoption of the amendment, while Mr. Cadmus desired an elucidation of the objects of the advisory committee. Mr. Woglom and Mr. Kimball endeavored to supply this information. Mr. Cadmus wanted the so-called advisory board to be called by some other name. The amendment was ultimately unanimously carried. The nominating committee reported the following nominations: For president, Henry Hayes; for third vice-president for two years, John R. Greason; for fourth vice-president for two years, Oliver G. Fessenden; for executive committee for two years, C. E. Breckenbridge, Bernard Karsch and David N. Smith; for advisory committee for two years, S. H. Levy, C. C. Offerman and W. A. Wightman.

Here Mr. Bardel suggested that the names of the additional members of the

advisory board be presented. They were read as follows: M. Stratton, with Alling & Co.; L. S. Lewis, with M. Prager; S. B. Mann, with Aikin, Lambert & Co.; William Barthman, T. B. Parker, with Martin, Copeland & Co., and D. V. P. Cadmus, with C. F. Wood & Co.

All these gentlemen were elected unanimously, the secretary being instructed to cast one ballot for each candidate.

These gentlemen were elected the nominating committee: Andrew McCloud, Leo Wormser, W. E. Mouteux and Gen. Geo. W. Mindil.

Upon the motion of Mr. Lissauer a telegram was sent to Henry Hayes, announcing his election as president of the League.

Mr. Lissauer moved that the 25th anniversary of the League, in June, 1902, be celebrated by a grand banquet, at which all the members should be invited to attend, the matter being left to a meeting of the executive committee. Mr. Woglom moved that a former motion to have an annual dinner of those who have brought at least one new member into the League during the previous year, placed upon the table; also be referred to the executive committee. Mr. Van Deventer argued that the executive committee will be able to arrange for a celebration of the 25th anniversary, and moved that the whole matter be left to the committee. Referred to the committee.

Chairman Bowden, before the meeting closed, made an eloquent appeal that the members urge their friends to join the League.

Mr. Parker followed, by promising to get at least one new member during the coming year, and urged his fellow members to do so also.

A vote of thanks was extended to the trade press, the motion being made by the chairman. A vote of thanks was extended to Mr. Bowden for his able work on the platform.

Fuller details of the recent robbery of the store of D. N. Walford, Washington, D. C., are as follows: The robbery consisted of one tray containing six dozen plain gold wedding rings, 14 and 18 karat. The robber on the night of Jan. 1 broke the plate glass window at the side, making a hole about large enough to get the tray through, which was on a glass shelf and had carelessly been left in the window, instead of being locked in the safe, as usual. Owing to the side glass being covered with drapery, no opening was visible and the burglar was given time to leave Washington, but the detectives traced him to Baltimore, where he had pawned six of the rings, and, as they have a description of the man, they expect to capture him.

## Jewelers and the French Treaty

### Legislators at Washington to Side with the Jewelers in Their Fight Against the Treaty.

ATTLEBORO, Mass., Jan. 15.—In last week's issue appeared a copy of the protest sent to Senators Nelson W. Aldrich and Henry Cabot Lodge and Representatives Melville Bull and William C. Lovering by the Company C Association Tariff Committee, which handles the fight of the New England jewelers against the provisions of the proposed reciprocity treaty with France now pending ratification or rejection in the Senate. The protest was sent to follow up the work which might have been accomplished by the petition on the same line sent the week previous. The petition evoked from the Congressmen addressed personal replies to Edward A. Sweeney, of the W. H. Wilmarth Co., the starter of the agitation. These replies were brief, but very gratifying. Before any further step was taken came the official replies to the tariff committee. These were as follows, having never until now appeared in print. From Hon. Henry Cabot Lodge, of Massachusetts:

"I have received your letter protesting against the ratification of the French reciprocity treaty without a proper amendment in regard to jewelry. I am very glad to be informed in regard to the matter and I shall call your letter at once to the attention of the committee having the treaty in charge."

From Hon. Nelson W. Aldrich, of Rhode Island:

"The treaty is now before the Senate Committee on Foreign Relations. I would suggest that you put your case as strongly as possible before Senator C. K. Davis, the chairman of the committee, as early as possible."

From Hon. William C. Lovering, in the House, from Massachusetts:

"I have your favor and notice what you say about the French reciprocity treaty as bearing upon the jewelry industry. Of course the ratification of this treaty is a Senatorial function, and it seems hard that the members of the House who are closer to the industries of the country than the Senators should not have something to say about it. However, you may rest assured that I will bring every influence I can to bear upon our Senators to have the jewelry industry considered."

From Hon. Melville Bull, in the House, from Rhode Island:

"I beg to acknowledge the receipt of the communication signed by yourself and other gentlemen of the Jewelry Tariff Committee of the Attleboros and Providence, protesting against the part of the proposed reciprocity treaty with France relative to lowering the rates of the present import duties on jewelry, for the purpose of protecting the jewelry industry of New England. My attention to this matter was brought through my colleague, Mr. Capron, who received a letter from Henry G. Thresher, of your committee, and he spoke to me with reference to taking some action concurrently with the other members of the New England delegation. From what talk I have had with the members I have gained the impression that it is very doubtful if the treaty, or at least that portion in question, is ratified. I beg to assure you that it will give me pleasure to cooperate with my colleagues in such manner as may seem best to prevent the adoption of the objectionable features of the treaty."

# The Mercantile National Bank

OF THE CITY OF NEW YORK,

BROADWAY AND DEY STREET,

Solicits Accounts from the Jewelry Trade.

**Providence.**

Arthur J. Meyers has removed from Page St. to 363 Eddy St.

H. Bernstein, formerly in business at 59 Page St., is now with Max Dcutz, 26 Fountain St.

At 38 Friendship St., in the shop formerly occupied by Charles S. Pine & Co., the new firm of Streeter & Covell may now be found.

Among the buyers who visited the city the week past were: F. E. Buffum, representing D. C. Percival & Co., Boston; J. A. Pitts, Montreal; O. E. Bell, Cincinnati; C. C. McFarlane, of Johnson & McFarlane, New York and Canada; Messrs. Tolman and Collins, of Chicago; William H. Garfield, of J. J. Moore & Co., Philadelphia; American Jewelry Co., Grand Rapids, Mich.; Charles Lippman and E. W. Spier, of Lippman, Spier & Hahn, New York.

The annual report of the Collector of Customs for the Port of Providence contains some interesting figures relating to the importations of jewelry and precious stones the year past. Of clocks there was imported \$13,011 worth, the value by quarters of the importations being \$1,300, \$3,776, \$4,772 and \$3,163. The total value of jewelry and precious stones which came through the local custom house was \$523,961. The quarterly reports show that the third quarter was the largest in its value of these imports, the value by quarters being \$154,115, \$128,368, \$154,754, \$86,724. This is the most complete statement ever given out here.

The Gorham Mfg. Co. have recently installed better facilities for fire protection at their works in Elmwood. A fire near to the works demonstrated some little time ago that the water force in that vicinity was not adequate. Under the direction of master mechanic James M. Bogle the works have been placed in good condition for immunity from a disastrous blaze. An 8-inch supply pipe has been run into the yard from Earl St. to connect with the one from Adelaide Ave., and a complete circulation of water thus assured. One flush and two large stand pipe hydrants have been added to those already in use, and another underwriter pump has been added to the equipment of the pump-house. This pump will deliver 1,000 gallons a minute at the pressure of 85 pounds.

**The Attleboros.**

John Bradley, for 27 years a responsible employe of the Horton, Angell Co., died last week.

Herman T. Regnell, of Regnell, Bigney & Co., has returned from a tour of the trade in the Empire State.

Edwin B. Bullock, late of the W. H. Wilmarth Co., returned last week from a trip to California and other sections of the west in the interests of his mines.

Edward A. Robinson, owner of the three big factories styled the Robinson estate, near the Attleboro depot, is about to launch into the jewelry business on his own account.

Owing to the approach of the time for the taking of the census the probable pop-

ulation figure for Attleboro has become a fruitful theme for conversation and the local press. It seems to be agreed that the figure will be something over 10,000, an increase of some 2,000, directly traceable to the increased prosperity of the jewelry manufacturers.

Among the buyers who placed orders in the Attleboros the past week were: Mr. Tolman, for Marshall Field & Co., Chicago; Mr. Solomon, of Solomon Bros. & Gross, New York; a representative of M. Sickles & Sons, Philadelphia; Mr. Murphy, of Bearse, Murphy & Co., Portland, Me.; Mr. Lippman, of Lippman, Spier & Hahn, New York; A. Mendelssohn & Co., Boston; Mr. Lewald, of F. Lewald & Co., Chicago; R. N. Hirschfield, Kansas City; Mr. Kingsbacker, of Kingsbacker Bros., New York.

Sidney O. Bigney, of S. O. Bigney & Co., is authority for the statement that he will enter suit at law this week to prosecute two Providence firms for infringement upon his patent rights. He secured a patent on Sept. 12 last on a device which he named the "Bigney Vest Fob." It is a fob made of plated links with a pendant charm of the regular pattern. From the swivel of the fob runs a light chain to a button-hole bar, and the small chain guards the watch from being dropped. Mr. Bigney declares that the two firms referred to have copied the design so closely that they have infringed and he is disposed to fight the case.

Albert S. Ingraham, the Attleboro colorer, made a decided improvement in his plant the latter part of last week. Mac-

**You Want This and Want It Quick.**

You can't sell a lady who has a guard-chain another, but you can sell her a later style.

**THE "IS-A-BELL"**

is the correct up-to-date fad for 1900, approved by the "400." The elite will wear it, the masses can. It has utility, grace and beauty, and can be worn on any dress and in several ways (two are shown in illustrations, thereby pleasing individual tastes. On the chatelaines are spring rings from which may be worn the chatelaine, friendship hearts, purse, pencil, tablet, mirror, glove-buttoner or other chatelaine articles.

**Made in Plate, 14k. Gold-Filled, Sterling Silver and Solid Gold from \$1.50 Up.**

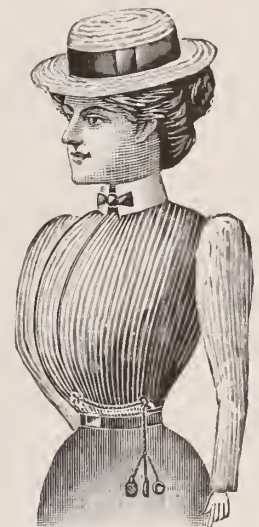

**MAY WE SEND YOU PREPAID A SAMPLE?** Orders filled direct to retail jewelers or through your jobber. Do not wait for your competitor to show your customers the first of **THE CORRECT THING AND BIGGEST SELLER EVER KNOWN IN LADIES' CHAINS.** Name and guarantee appear on all swivels and cards.

*Patents pending. Our rights will be fully protected against all imitators or parties handling imitations.*

**The O. E. BELL CO., Manufacturers,**  
**CINCINNATI, OHIO.**  
Factory, Mansfield, Ohio.

donald & Culver, in moving from the Bates steam power building, Railroad St., gave him the opportunity to more than triple his floor space by taking the quarters they vacated in addition to his own.

Frank Pettee, for years an employe of Robinson Bros., Plainville, died last week.

Fred W. Lincoln, of J. M. Fisher & Co., concluded last week his 20th year of devoted service at the head of the Attleboro Methodist Sunday school.

Theron I. Smith, of T. I. Smith & Co., with a party including his daughter, Mrs. Curtis, wife of Henry H. Curtis, of H. H. Curtis Co., went last week to California for a visit of several months' duration.

The new list of officers elected by the banking corporations include the following manufacturers as either executive officers or directors; Abiel Coddling, George A. Dean, Arthur E. Coddling, Fred E. Sturdy, George W. Cheever, J. Lyman Sweet, Edgar L. Hixon, John E. Tweedy, Charles E. Bliss, Louis J. Lamb and Albert Totten.

C. Ditto has moved his stock of jewelry from Davey to Ashland, Neb.

Guard chains continue to hold their place as the prevailing fad in women's jewelry. The latest style in these chains is called "Is-a-bell," and combines utility, grace and beauty in a manner to make it one of the leading sellers of the season. It is made in solid gold, 14 k. gold filled, gold plate and sterling silver, and can be worn on any dress and in several ways, two of which are illustrated on page 19. Jewelers should send for a sample to the makers, The O. E. Bell Co., Cincinnati, O.

#### Death of Henry Wood.

Henry Wood, one of New York's oldest silversmiths and senior member of Wood & Hughes, 24 John St., New York, died suddenly early Saturday morning at his



THE LATE HENRY WOOD.

residence, Broad St. and Leroy Place, Red Bank, N. J. Death was due to apoplexy and was totally unexpected. Mr. Wood had been suffering for some time with his eyes and was troubled with hemorrhages of

the retina, but otherwise, with the exception of a slight illness two weeks ago, had been in good health. Late Friday night he appeared somewhat restless, and finally about midnight went to bed. An apoplectic stroke seized him shortly after and he died about 1 o'clock a. m. Mr. Wood's name was familiar to the entire jewelry trade, he having been connected with the silversmithing business since his boyhood.

Mr. Wood was born in New City, Rockland County, 69 years ago, and coming to New York as a young man entered as an apprentice in his oldest brother's firm, Wood & Hughes, which concern had been founded in 1833 by Wm. Gale, Jacob Wood and Jos. H. Hughes. Jacob Wood and Jasper W. Hughes succeeded to this business in 1845, giving it the name which it has borne since that time. The deceased, after he had learned his trade, was finally given an interest in the concern in 1863, at which time the main partners were his other brother, Charles Wood, Stephen Fraprie and Charles H. Hughes. About this time also Dixon G. Hughes was given an interest in the concern, and the latter with Henry Wood became full partners with Mr. Fraprie in 1883. Mr. Fraprie died in 1889 and from 1890 to the present the deceased and Dixon G. Hughes continued the business. Throughout his long career Mr. Wood paid close attention to the needs of his business and gave little time to anything beside this and his family. During part of his career he had charge of the firm's office, and at other times looked after the factory. His specialty was the hollow ware end of the business.

The deceased was twice married and is survived by a widow.

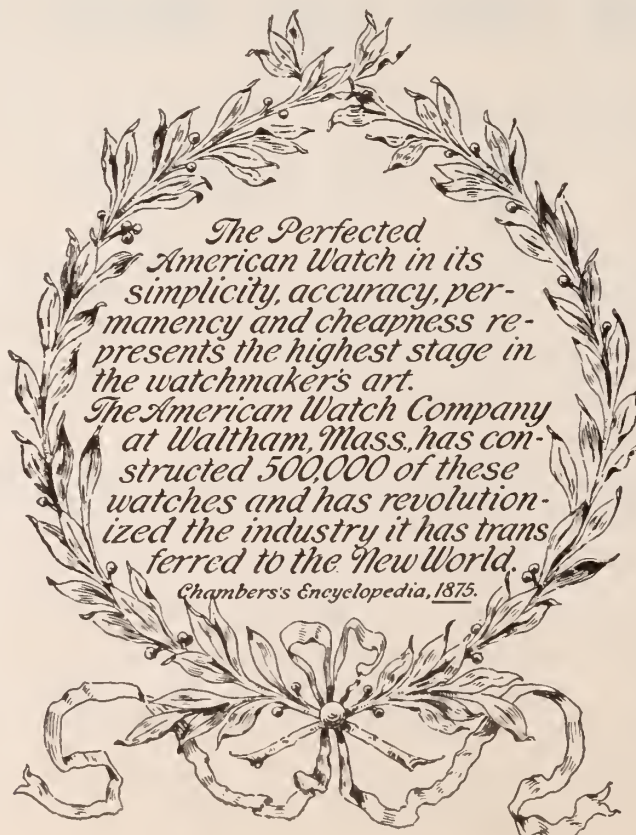



**Importations at the Port of New York.**

*Weeks Ended Jan. 13, 1899, and Jan. 12, 1900.*

China, Glass and Earthen Ware:	1899.	1900.
China .....	\$43,061	\$38,755
Earthen ware .....	12,165	23,596
Glass ware .....	9,249	15,745
Optical glass .....		1,895
Instruments:		
Musical .....	8,618	.....
Optical .....	2,423	993
Philosophical .....	2,718	4,245
Jewelry, etc.:		
Jewelry .....	12,397	7,336
Precious stones .....	244,681	61,096
Watches .....	4,592	9,046
Metals, etc.:		
Bronzes .....	200	1,604
Cutlery .....	14,058	18,645
Dutch metal .....	553	3,477
Platina .....	15,003	72,980
Plated ware .....	231	.....
Silver ware .....	1,286	2,038
Miscellaneous:		
Alabaster ornaments .....	39	951
Amber .....	569	959
Beads .....	3,583	1,014
Clocks .....	2,208	2,893
Fans .....	16,703	5,028
Fancy goods .....	3,721	8,119
Ivory .....		3,512
Ivory, manufactures of.....	242	2,206
Marble, manufactures of.....	6,362	5,789
Statuary .....	768	2,341

Gen. W. P. Hazen is said to be the owner of something rare in the way of a watch. This timepiece, it is claimed, came to this country on the *Mayflower*, and has been kept track of ever since. The case is of gold and is much thicker than are cases in this day. It is beautifully inlaid with precious stones and highly ornamented.

**Pennsylvania's Auction Law Upheld and E. P. Percival Must Pay a Fine.**

PHILADELPHIA, Pa., Jan. 12.—Ebenezer P. Percival must pay a fine of \$500 for selling watches at Mount Gretna in violation of the State auction laws. He was convicted in the Criminal Court of Lebanon, Pa., in August, 1898, but appealed to the Superior Court, which affirmed the decision of the lower court, and thence to the Supreme Court, which last Thursday discharged the rule to show cause why an appeal from the Superior Court should not be allowed.

Percival's case involved questions of importance to the trade which have now been definitely settled to the relief of the legitimate jewelers of the country districts, whose trade has been invaded by hawkers, peddlers and auction promoters, without the payment of the just and proper license fees.

His offence was a violation of the Act of April 2, 1830, regulating auction sales. During the various legal proceedings Percival has raised the point that he was a manufacturer, and as such had a right to dispose of his goods without restriction from the courts. He also alleged that the Act was unconstitutional. From the evidence it appeared that Percival purchased movements, dials, springs, hands and cases separately, assembled the parts and put them in marketable condition as watches.

This proceeding the courts held did not constitute him a manufacturer in the eyes of the law. All the prominent local manufacturing and retail jewelers heartily en-

dorse this opinion and all of them are relieved that the Act of April 2, 1830, has been upheld.

**Herman Diesinger Claims to Have Been Swindled Out of \$5,000.**

PHILADELPHIA, Pa., Jan. 10.—Herman Diesinger, formerly of Hamilton & Diesinger and who recently retired from business, says he has been swindled out of \$5,000 by Edward I. Wilson, confidential agent of the firm of Stahl & Straub, bankrupt stock-brokers. The note which transferred this amount was indorsed by Emil J. Hertz, who had the diamond corner in Hamilton & Diesinger's store. He is much interested in the recovery of the money.

Mr. Diesinger and Mr. Hertz allege that they have been swindled. Accordingly, at Mr. Diesinger's instigation, a warrant was issued for the arrest of Wilson on a charge of conspiracy to swindle the jewelers. He was given a hearing before Magistrate Cunningham yesterday and held in \$1,500 bail for court. The bail was furnished by Simon Bacharach. Wilson is now under bonds aggregating \$6,500.

**Woman Editor Charged with Stealing from Several Philadelphia Stores.**

PHILADELPHIA, Pa., Jan. 13.—Mrs. Elizabeth Everett, formerly editor of the woman's page of the *Philadelphia Times*, has been held in \$2,100 bail on the charge of stealing diamonds worth \$1,215 from Chestnut St. establishments. She has borne an excellent reputation heretofore,

# MACHINERY

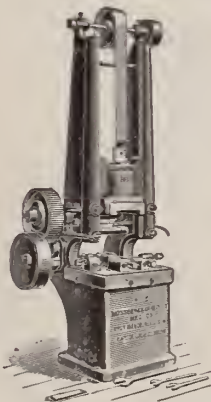

No. 5 Automatic Drop Press. Made in 12 Sizes.

**UP TO DATE** is what enterprising Jewelers and Silversmiths want and must have in order to do business in a satisfactory and profitable manner. For years we have made a special study of the wants of the Jeweler and Silversmith, and are prepared to furnish the best designed

- DROP PRESSES,
- ROLLING MILLS, Fitted with Roller Bearings;
- FOOT PRESSES,
- ROTARY SHEARS,
- HAND PRESSES,
- INGOT MOULDS,
- POWER PRESSES,
- LAP LATHES,
- COINING PRESSES,
- WIRE COILERS,
- WIRE POINTERS,
- DRAW BENCHES.

## MOSSBERG & GRANVILLE MFG. CO.,

NEW YORK, 126 Liberty St.

PROVIDENCE, R. I.

Philadelphia Bourse.

WESTERN OFFICE: Mercantile Bank Building, Cleveland, Ohio.

## A Money-Saving, Money-Making Plan

We have a **SPECIAL PROPOSITION** to offer to you whereby you can buy **Bell Gold-Filled Watch Cases** at a lower price than any of your competitors, undersell them, and make larger profits. It is designed especially for the retailers' interests, and is a money-making opportunity that should be quickly grasped.

WRITE FOR FULL PARTICULARS.



No. 5535.

This is one of many 16 and 18 size Hurting, Engraved Cases, warranted to wear for 25 years.

**Price, \$7.27 Net,**

or in Open-Face, Engraved,

**\$4.47 Net.**

Any emblem or monogram, plain or engine-turned made to order for 25c. to \$1.00 extra.

BUY OF THE MAKER.

**The Bell Watch Case Co.,**  
**CINCINNATI, OHIO.**

and the charges against her created a sensation in local newspaper, jewelry and social circles. Mrs. Everett has published two books and is said to have earned as much as \$8,000 a year by her pen. She lives at 820 N. Broad St.

It was in evidence that she entered Willmott's jewelry store, 724 Chestnut St., and asked to be shown diamonds. A salesman placed a tray before her and began to exhibit the stones. Mrs. Everett seemed much interested, but left the store without making a purchase. After her departure it was discovered that a pair of \$250 earrings were missing. Mrs. Everett was arrested and confessed.

It was later discovered that she had stolen two brooches worth \$500 from Strawbridge & Clothier's and jewels from Wanamaker's, J. E. Caldwell & Co.'s and Bailey, Banks & Biddle Co.'s. Lots of pawn tickets were found in her possession. In default of \$2,100 bail she was sent to prison.

### Bunco Game Worked Upon Jeweler Ezra E. Rubin.

Boston, Mass., Jan. 15.—Ezra E. Rubin, retail jeweler, 31 Green St., was victimized Friday by a couple of swindlers, who made his acquaintance and induced him to call at their rooms on Chambers St., near his store, and bring with him a diamond ring valued at upward of \$200, to show to "the woman in the case."

It is claimed by Rubin, who reported his loss to the police, that they gave the names of Mr. and Mrs. Thomas Butler, that when he called at their rooms "Mrs. Butler" put on the ring and went out, ostensibly to show it to her husband in an adjoining room, but did not return. Word came from Worcester, Mass., Saturday night that Butler had been arrested in that city, to answer to Rubin's charges.

Frank May, an Italian shoemaker, was arraigned in police court in Passaic, N. J., a few days ago, on a charge of having attempted to assault Samuel Schulman, jeweler. May purchased a watch from Schulman and then tired of his bargain. He returned it, but was paid \$27, \$3 less than the purchase price. He argued with the jeweler and a fracas followed. The jeweler caused his arrest. The Judge dismissed the case.

### Proceedings of the Jewelers' Security Alliance.

The regular monthly meeting of the executive committee of the Jewelers' Security Alliance was held on Jan. 12, the following being present: President Bowden, Secretary Noyes and Messrs. Stern, Abbott and Untermeyer, of the committee.

The following new members were admitted: Henry O. Arnzen, Brooklyn, N. Y.; Chas. W. Brown, Charlestown, W. Va.; Nathaniel C. Cochran, Fairmont, W. Va.; Morris Herzberg, Philadelphia, Pa.; Shreve & Co., San Francisco, Cal.; Shreve & Co., San Francisco, Cal.; Chas. J. Stein, Greenwood, Miss.; W. S. Still, Delavan, Ill.; Cornell & Andrews, Providence, R. I.; W. H. McConahay, Salt Lake City, Utah; Alban N. Peoples, Chester, Pa.; C. W. Deans, Spencer, Mass.; P. G. Diener, Harrisburg, Pa.; D. F. Hinkins, Winchester, Va.; A. A. Cowing, Watkins, N. Y.; William H. Winhaus, N. Y. City; F. Lyman, Bridgeport, Conn.; Geo. H. Atwell, Boston, Mass.; G. Beninghousen, Seattle, Wash.; W. W. Fairchild, New York; Sydney H. Hart, Houston, Tex.; P. L. Lowenthal, Bradford, Pa.; E. E. Ephraim, Galveston, Tex.; Migels Loan Co., Galveston, Tex.; Seth A. Huson, Buffalo, N. Y.; Wayne Young, Caldwell, O.; Van Sickle & Farnum, Port Jervis, N. Y.; Frank, Laubach & Clemmer Co., Akron, O.; Daniel J. Sullivan, New Bedford, Mass.

The following communication is of interest:

MUKWONAGO, Wis., Jan. 5, 1900.

MR. JAS. H. NOYES, Sec'y.

Jewelers' Security Alliance.

DEAR SIR:—Early on the morning of Dec. 2, burglars made an attempt to blow open the safe of the bank, using a number of charges of nitroglycerine. Being one of the best safes made, they did not gain an entrance before the citizens got after them and frightened them away. The singular part of it to most of the people here was that they did not attempt to open my safe which is located in the same room. It was a satisfaction to me to point to the sign of the Security Alliance and say that they evidently had a good deal of respect for that piece of paper. A number of other safes in the village have been blown open in the last few years, but mine has never been molested in the least. Every jeweler ought to be a member of the "Alliance" for the feeling of security it gives. I never worry about burglars breaking my safe, thanks to the "Jewelers' Security Alliance."

Yours very truly,

PERRY P. CAMP.

E. I. Pittman, Ennis, Tex., has removed to another store on Main St.

CATSEYES	SAPPHIRES	DIAMONDS	RUBIES	EMERALDS	PEARLS	PEARL NECKS	PEARL ROPES
OLIVINES	OPALS	RUBIES	SCIENTIFIC				
<p><b>PEARLS, DRILLED AND UNDRILLED.</b></p> <p><b>PEARL ROPES, NECKS and COLLARETTES.</b></p> <p><b>We are buyers of American Pearls.</b></p> <p>LONDON: 19-20 Holborn Viaduct. <b>JOSEPH FRANKEL'S SONS,</b> 68 Nassau Street, NEW YORK.</p> <p>TELEPHONE, 2733 JOHN.</p> <p>FANCY COLORED DIAMONDS and GEMS in PEARLS and PRECIOUS STONES.</p>							
							Pearl Collarettes, mounted with Diamond Bars.

**Fire in the Jewelers Building, of Boston, Causes Excitement.**

BOSTON, Mass., Jan. 15.—There was considerable excitement this afternoon on the fifth floor of the Jewelers building when it was discovered that a pretty good blaze was under way in the salesrooms of William Fenton, Boston representative of the Wm. L. Gilbert Clock Co. The fire was discovered by Mr. Eldridge, city salesman for Mr. Fenton, among some excelsior in and about a few packing cases in one corner of the salesroom. Luckily the building has hose connections on every floor, and the fire was practically out when the city fire apparatus reached the building, the tenants themselves forming an efficient fire fighting force.

The stock of clocks, bronzes and other articles in Mr. Fenton's sample outfit was valued at close to \$2,000, and suffered considerable damage by smoke and water. None of the other tenants, however, will lose materially, nor is the building itself damaged more than slightly.

**Death of Henry Blundell.**

PROVIDENCE, R. I., Jan. 15.—Henry Blundell, founder of Henry Blundell & Co., manufacturers of machinists' and jewelers' tools, died at his home, 226 Lockwood St., this morning. Mr. Blundell was 84 years of age, being born Jan. 17, 1816, in England, where he received his early education and training. In 1842 he came to this city, first working in a brass foundry, and later organizing the firm which bore

his name. He retired from active business in 1888, and since that time has led a life of leisure, having disposed of his business interests to his sons. Two sons and two daughters survive him.

**Diamond Swindler Schwartz Will Not Be Taken to Iowa.**

JEFFERSON CITY, Mo., Jan. 10.—Joseph Schwartz, the diamond sharp who last month sold diamonds to some Council Bluffs, Ia., pawnbrokers who afterward decided that there was something wrong with the stones which they had bought while under the impression that they were not paying over half price for them, and had him arrested, got a requisition from the Governor of Missouri, had the Iowa officers go to Kansas City and start for Iowa with their prisoner, merely to be met at the depot in St. Joseph, Mo., by officers with a writ of habeas corpus, which secured his release under bond subject to the outcome of a rehearing of the application for requisition papers.

Frank P. Sebee, of Kansas City, was before Governor Stephens to-day and filed affidavits and papers in opposition to the honoring of the extradition papers of the Governor of Iowa for the return to Council Bluffs for trial of Joseph Schwartz, on the charge of selling bogus diamonds there. Last week the Governor honored the requisition, but on representations that the Iowa authorities were using the original process to collect a debt he rescinded his action, and Schwartz was released on bond. The Governor set the case for hear-

OTTO K. TREIBS.

PAUL E. TREIBS.

**TREIBS BROS.,**

68 Nassau St., New York.

139 Mathewson St., Providence, R. I.

CUTTERS AND IMPORTERS OF

**Opals.**

F. E. TREIBS,

Oberstein,

Germany.

ESTABLISHED 1842.

HERMANN TREIBS.

ALBERT TREIBS.

EMIL TREIBS.

**Vrieslander & Moreels, Commission Merchants.**

We buy Rough Diamonds

for 1 per cent commission.

We cut Melées specially

for the American market.

Best New York References.

Correspondence Solicited.

Temporary address,

5 Rue Van Lier,

ANTWERP, BELGIUM.

**"OMEGA" WATCHES.**

NONE BETTER MADE. OVER 1,000,000 IN USE.

GOOD SELLERS EVERY DAY IN THE YEAR.



Pendant Set. 12, 14 and 16 Size. Made in Gun Metal, Silver, Gold-Filled and Solid Gold Cases.

Place your orders early in the year for these watches and avoid later on the embarrassment of delay that you experienced last season.

We will accept orders and deliver WHEN you wish them.

These watches are sold only to the legitimate trade.

No prices advertised in any journal.

Made in 00 size.

" " 0 size.

" " 12 size.

" " 16 size.

**Edmund E. Robert, 3 Maiden Lane, N. Y.;**

**Cross & Beguelin, 17 Maiden Lane, N. Y.,**

SOLE SELLING AGENTS.

**Send for Price-List.**

1900. Everybody Happy!

**THE RETAIL TRADE**

should hasten to replenish their stock of

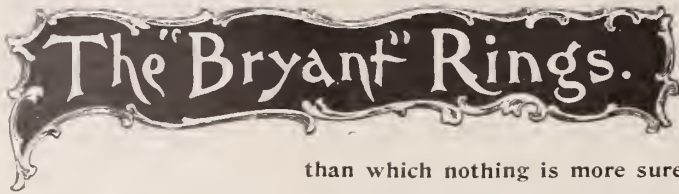

than which nothing is more sure of sale.

DON'T WAIT FOR OUR TRAVELERS, BUT SEND AT ONCE TO

**M. B. BRYANT & CO.,**

10 MAIDEN LANE,

NEW YORK.

**THE STANDARD CASES**

ARE THE

**Bates & Bacon Gold-Filled Watch Cases**

<b>FAVORITE,</b>	<b>ROYAL,</b>	<b>REGAL,</b>	<b>PURITAN,</b>
14k. FILLED, Guaranteed 25 Years.	14k. FILLED, Guaranteed 20 Years.	GUARANTEED 10 YEARS.	GUARANTEED 5 YEARS.

**BATES & BACON,**

103 STATE STREET,  
CHICAGO.

11 JOHN STREET,  
NEW YORK.

**EMPIRE COMBS. SIDE COMBS.**

GOLD AND JEWELLED ORNAMENTED.

SPECIALTIES IN ROMAN WORK.

**DAY, CLARK & Co.,**

MAKERS OF FINE JEWELRY,

23 MAIDEN LANE, N. Y.



**Eliassof Bros. & Co.,**

IMPORTERS AND JOBBERS OF

**DIAMONDS, WATCHES, JEWELRY,**

9-11-13 Maiden Lane,

Materials, Tools and Optical Goods.

NEW YORK.

ALBANY OFFICE: 62 & 64 STATE STREET.



GOLD SHELL.

*"Buy direct from the manufacturer and get all that is coming to you."*

SEND FOR OUR "HOT CATALOGUE, CONTAINING COLD FACTS AND PRETTY PICTURES."

**CLARK & COOMBS,**

86 WEST EXCHANGE ST., - PROVIDENCE, R. I.

WE ARE HEADQUARTERS FOR.....

**Gold Shell Rings...**

ing this afternoon. No one appeared for the Iowa people, and hence it is supposed they intend to drop it. It is stated on good authority that they have received their money, and, as they did not appear before the Governor, the latter refused to honor the requisition.

**Sam Mayer Reports Himself as Being Insolvent.**

The creditors of Sam Mayer, Denver, Col., have received word from Mr. Mayer stating that he is insolvent and offering to take such steps as the creditors deem best for their interest in order to pay the largest amount possible. According to Mr. Mayer's statement his liabilities are about \$97,000, while his assets are worth something over \$50,000. In his assets is about \$40,000 worth of stock, \$6,000 worth of good accounts and about \$5,000 in personal assets, such as equity in real estate, mining shares, etc. A conference of Mr. Mayer's largest creditors was held Monday afternoon at the rooms of the Jewelers' Association and Board of Trade, New York, at which it was decided to call a general meeting of the creditors to-day.

**C. S. Raymond Sons in the Hands of a Receiver.**

KANSAS CITY, Mo., Jan. 13.—C. S. Raymond Sons went into the hands of a receiver on the 10th. They opened here a few months ago. C. S. Raymond, the father, was in the jewelry business for years at Omaha, Neb., and was widely known and well regarded in the trade.

**Bill Authorizing Use of Trade-Stamps in New York Legislature.**

ALBANY, N. Y., Jan. 12.—Assemblyman O'Connell, of New York, has introduced in the Legislature a bill authorizing the use of trading stamps, trading checks and similar gift enterprises.

**Jewelers' Gold Bars Withdrawn and Exchanged.**

Week Ended Jan. 13, 1900.

The U. S. Assay Office report:  
Gold bars exchanged for gold coin..... \$172,615.29  
Gold bars paid depositors..... 80,853.19

Total .....	\$253,473.78
Of this the gold bars exchanged for gold coin are reported by the Sub-Treasury as follows:	
Jan. 8.....	\$30,928
" 9.....	36,649
" 10.....	15,977
" 11.....	30,014
" 12.....	18,070
" 13.....	.....
Total .....	\$131,638

The annual meeting of the Baltimore Sterling Silver Co., Baltimore, Md., was held Jan. 12, at the office of the company, 17 N. Liberty St. The proposition to increase the capital stock of the company from \$6,000 to \$100,000 was discussed. It was favored, but no final action was taken, as counsel for the company stated that not sufficient notice of the meeting had been given. An adjourned meeting will be held in a few weeks, when action on the proposition will be taken. The following officers were elected: President, Frederick Bucker; vice-president, Roger T. Gill; secretary and treasurer, J. M. Smith, and manager, Charles C. Stieff.

**Our Traveling**

**Representatives**



Traveling representatives may consider these columns open for the publication of any news or items of interest regarding themselves or their confreres.

Fred Bowen, of Omaha, Neb., has accepted a position as traveling salesman with the Reed, Bennett Co., Minneapolis, Minn.

F. E. Finch has resigned as traveling salesman for Sischo & Beard, St. Paul, Minn.

W. R. Cooper, who represented S. H. Clausin & Co., Minneapolis, Minn., on the road the past year, has severed his connection with that firm and has gone east.

Al. Moyer, of the Non-Retailing Co., Lancaster, Pa., left on Monday on a trip through northern Pennsylvania.

Simon Miller will hereafter represent Leo Goldsmith, 65 Nassau St., New York, in New York, Newark, Boston and Providence.

The trade of Lancaster, Pa., were visited the past week by C. G. Cushman, Reed & Barton; W. H. Roland, Meriden, Conn., and McIntyre, Magee & Brown's representative.

Fred H. Perry, the youngest and one of the most successful traveling men in the Attleboro, returned Saturday from his last trip in the interests of O. W. Hawkins & Co. He starts out directly with the grip of the W. H. Wilmarth Co.

Among the traveling men in Boston, Mass., the past week were: Frank L. Wood, Ludwig Nissen & Co.; W. R. Cattelle, Henry E. Oppenheimer & Co.; Charles S. Isabel, L. Strasburger's Son & Co.; Alex. Chase; A. B. Wells, American Optical Co.; John A. Abel.

C. B. Smith, formerly with the S. B. Champlin Co., Providence, R. I., will hereafter represent M. B. Bryant & Co., ring manufacturers, 10 Maiden Lane, New York. For his new employers, Mr. Smith will visit the territory formerly covered in their interests by C. H. Anderson.

Codding & Heilborn Co., North Attleboro, Mass., have engaged J. K. Thompson, of late with the Gorham Mfg. Co.'s Maiden Lane store, New York, to represent them through the middle west. Mr. Thompson has been associated with the jewelry business for years and is thoroughly conversant with the line.

Among the travelers in Detroit, Mich., last week were: Fred J. Foster, Unger Brothers; M. Birnheim, Woodside Sterling Co.; A. H. Colby, Towle Mfg. Co.; H. B. Bliss, Gorham Mfg. Co.; G. W. Payson, Seth Thomas Clock Co.; A. M. Dillon, The Meriden Cutlery Co., and Mr. Williams, Eaton-Hulbert Stationery Co.

E. A. Cowan, Boston, Mass., will start this week on a southern trip of several weeks' duration, visiting the principal cities as far as the Gulf. W. F. Macomber, formerly in the New England and eastern circuit, will travel southwest on his next trip, and George F. Garland will take the routes that Mr. Macomber covered.

Among the rare specimens of jewelry travelers making their appearance in Syracuse, N. Y., the past week were noticed: Fred J. Foster, Unger Bros.; E. B. Downs, Hayden W. Wheeler & Co.; C. S. Fake, Whiting Mfg. Co.; M. Klipper, Hipp, Didisheim & Bro.; C. D. Hintze, Enos Richardson & Co.; Fred Gick, Frank M. Whiting & Co.; G. L. Sweet, R. F. Simmons & Co.

Eastern jobbers and manufacturers represented in the Twin Cities the past week were: Goldsmith Bros. by I. Speyer; G. H. Fuller & Son Co. by W. A. Lamb; Theodore W. Foster & Bro. Co. by Mr. Limbach; F. H. Noble & Co. by A. L. Reach; J. M. Fisher & Co. by Mr. Potter; S. O. Bigney

& Co. by Mr. Somes; A. A. Greene & Co., D. F. Briggs Co., both by S. Sandfelder.

W. B. Marble, representing Smith, Marble & Forester, has resumed his trip after being laid up at the Hloning hotel, Cincinnati, O., for a week or so. A few traveling men were seen in Cincinnati, O., last week, among them, Messrs. McDonough, Courvoisier-Wilcox Mfg. Co.; L. B. Hodges, E. A. Potter & Co.; George Southwick, Union Braiding Co.; E. L. Spencer, of E. L. Spencer & Co.; John Keane, Ostby & Barton Co.; A. Bradshaw, Meriden Britannia Co.

The following men recently visited Columbus, O., dealers: Harry Rolfe, Derby Silver Co.; Harry Tibbals, Wilcox Silver Plate Co.; Roman Waushoski, I. Ollendorf; L. J. Roehr, Bassett Jewelry Co.; E. R. Kant, Green Bros.; T. C. Keys, L. E. Waterman Co.; T. H. B. Davis, International Silver Co.; F. N. Wilcox, International Silver Co.; Robert B. Steele, J. B. Bowden & Co.; Lucian Rockwell, Poole Silver Co.; W. F. Dean, Reed & Barton; Harry Bliss, Gorham Mfg. Co.; A. L. Fuller, Towle Mfg. Co.; M. Klipper, Hipp, Didisheim & Bro.

Traveling representatives in Indianapolis, Ind., last week included: F. V. Kennon, John T. Mauran Mfg. Co.; George C. Booth, Hutchison & Huestis; George A. Schaefer, Regnell, Bigney & Co.; Mr. Hodgins, Tarrant & Gismond; Max L. Jacoby, Manchester Mfg. Co.; Richard Robinson, T. G. Frothingham & Co.; Jack Fuller, Fuller, Carpenter & Co.; G. Goldberg, W. & S. Blackinton; H. L. Stanton; Mr. Heymen, Stern Bros. & Co.; Mr. Rhodes, Rhodes Bros.; E. R. Bennett; Mr. Joseph, M. B. & H. H. Joseph; J. B. Taft, Geo. H. Holmes & Co.; Ed. Spencer, E. L. Spencer & Co.

Among the travelers in St. Louis, Mo., last week were: Mr. Dorrance, Simons, Bro. & Co.; J. W. McClannin, Wilcox Silver Plate Co.; H. C. Rowbotham, C. P. Goldsmith & Co.; Chas. B. Bartlett, Whiting Mfg. Co.; E. A. Reed, Reed & Barton; L. T. Field, W. G. Clark & Co.; Fred H. Carpenter, Fuller, Carpenter & Co.; Mr. Platt, J. A. Deknatel & Co.; Edwin L. Mumford, Waite, Thresher Co.; H. A. Scofield, Scofield, Melcher & Scofield; Louis Hirsch, Hirsch, Flashner & Robbins; A. L. Reach, F. H. Noble & Co.; H. E. Cobb, Daggett & Clap Co.; Ernest Block, Louis Stern & Co.; Richard Robinson, T. G. Frothingham & Co.; E. E. Cobb, McDonald & Culver; M. B. Joseph, M. B. & H. H. Joseph; Milt S. Rodenberg, Rodenberg & Dunn; Mr. Steere, Geo. L. Brown & Co.; Ben Crandall, J. L. Crandall & Co.; A. H. Oakley, Thornton Bros.

Travelers in Pittsburgh, Pa., last week were: J. F. Dean, Reed & Barton; G. L. Sweet, R. F. Simmons & Co.; Louis Hirsch, Hirsch, Flashner & Robbins; C. E. Settle, for O. M. Draper; Wm. Bosselman, T. Quayle & Co.; S. C. Corbin, Waterbury Clock Co.; Dan Wile, Buffalo Jewelry Case Co.; Arthur Bradshaw, Meriden Britannia Co.; Geo. Southwick, Union Braiding Co.; Sam H. Fink, Fink, Bodenheimer & Co.; G. E. Tinker, Wm. B. Durgin Co.; T. H. B. Davis, International Silver Co.; Max Huss, S. & A. Borgzinner; D. Skutch, New Haven Clock Co.; Charles C. Orcutt, Chester Billings & Son; F. J. Wildes, International Silver Co.; Mr. Cook, Fontneau & Cook; Frank E. Whitmarsh, Alvin Mfg. Co.; Mr. Rhodes, Rhodes Bros.; Albert L. Stearns, Roy Watch Case Co.; Mr. Van Sant, Simons, Bro. & Co.; Mr. Hodgins, Tarrant & Gismond; E. A. Reed, Reed & Barton; Lewis P. Cook, J. F. Fradley & Co.; H. C. Rowbotham, G. P. Goldsmith & Co.

**Death of C. F. Willemin.**

C. F. Willemin, the old time traveler for T. G. Frothingham & Co., North Attleboro, Mass., who died recently at Brooklyn, N. Y., will be kindly remembered by his friends, whose names are legion. Mr. Willemin was a conscientious worker whose departure will be missed by the business community of the west, on whom he made his regular calls.

**A. & B.**

**HEADQUARTERS**

FOR

**Waltham Watches**

EVERY GRADE.

**AVERY & BROWN,**

68 Nassau St., New York.

THIS IS THE SEASON TO RENOVATE YOUR

**Catalogue**

DROP US A POSTAL AND WE WILL BE PLEASED TO FURNISH ESTIMATES FOR YOUR WORK.

**MERIDEN GRAVURE CO.,**  
MERIDEN, CONN.

**Survival of the Fittest.**

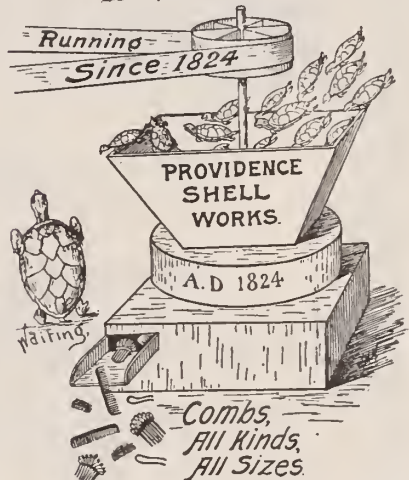

**POTTER'S COMB FACTORY,**  
PROVIDENCE, R.I.

**We Grind for You,**  
**Send along your Work.**



**THE MAUSER MFG. COMPANY,**  
**SILVERSMITHS,**

"Watch Our Ads." 15th St., bet. Broadway and Fifth Ave., New York.

## Philadelphia.

### TRADE CONDITIONS.

Local jobbers are unanimous in declaring the business conditions of the past week to have been most encouraging. Preparations for the Spring season are going forward in a way which indicates that jewelers, generally, indulge confident anticipations of a prosperous business. Productive capacity in Simons, Bro. & Co.'s establishment and some of the big watch making industries is said to be under contract for three, four, five and six months ahead.

The store of John Sassaman, Pottstown, was robbed of valuable trinkets last week.

Louis Lipkin, jeweler, 716 South St., was married last week to Miss Rebecca Himelfarb.

James W. Barry, secretary of the Jewelers' Club, has recovered from an attack of pleurisy.

Adam Fordham, for many years watchman at H. Muhr's Sons' store, 1110 Chestnut St., died last Friday.

Queen & Co., Inc., are the only local firm in the trade who intend to make a display at the Paris Exposition.

The stock of the jewelry store of George Eakins & Son, 930 Chestnut St., is being sold under the auctioneer's hammer.

The will of John M. Scherr, Sr., father of George W. Scherr, jobber, was probated last week. It disposes of an estate worth \$4,800.

The hearing of the application for the discharge of B. Frank Williams, formerly D. F. Conover & Co., as a bankrupt will be heard Friday in the United States District Court.

The case of the Keystone Watch Case

Co. vs. the Fourth St. National bank, appealed from Common Pleas Court No. 1, was listed for argument in the Supreme Court on Jan. 15.

Frederick M. Simons, of Simons, Bro. & Co., has been re-elected a director of the Merchants' National bank. He has also been nominated as a director of the Trades League. The election will be held next Thursday.

As a result of the stop-off privileges secured from the railroads, largely by the efforts of the Trades League, of which organization all the prominent local jewelers are members, the manufacturers and jobbers of Philadelphia anticipate to secure during 1900 a larger proportion than ever of the southern and western business.

## Boston.

The employes of J. Edward Wilson held their ninth annual dinner last Tuesday evening at Mieusset's, Mr. Wilson being the guest of his salesmen.

Thomas B. Hennigar, who recently sold out his interest in the retail store of Derry & Hennigar to E. A. Bigelow, has taken office quarters at 64 Chauncey St., and is conducting a city jobbing trade in jewelry.

Boston firms are among the interested creditors of F. B. Greene, Booth Bay Harbor, Me., who has assigned to G. B. Keniston and A. R. Nickerson. No statement of liabilities and assets was made when notices of the assignment were issued.

For the meeting of the New England Association of Opticians, scheduled to oc-

cur Jan. 16, it was announced that C. N. Quimby, a member, would address the association on the subject of "Light Waves, Visible and Invisible. How Measured. Polarization."

The Boston Jewelers' Club will hold their annual meeting Feb. 13. Election of officers will precede the dinner, and a committee will presumably be appointed to arrange for the ladies' night banquet in March or April, as is customary each year at the annual meeting of the club.

Buyers in town the past week included: H. E. Murdock, Portland, Me.; George H. Brown, Manchester, N. H.; J. H. Otis, Kennebunk, Me.; Stacy L. Rogers, accompanied by Mrs. Rogers, Bangor, Me.; W. T. Almy, New Bedford; H. E. Burdick, who is fitting up a new store in Lynn, Mass.; F. M. Nichols, Taunton; Mr. Bernstein, Bernstein Bros., Portland, Me.

Quite a number of members of the Boston jewelry and optical trades who were depositors in the Broadway National bank are congratulating themselves on a happy issue from the inconveniences occasioned by the tying up of that institution during the December panic. Receivers' certificates for their deposits have been granted, and they have transferred their accounts through that medium to other banks.

E. C. Bechtold, who has conducted a jewelry store on N. Main St., Pittston, Pa., the past four years, has disposed of his business to J. Freed, who conducts a jewelry store in the Elterich building, N. Main St.

# About Watches.

## THIS IS THE WAY WE REASON:

We buy right; we sell right. There are no WATCH PEOPLE who can or will do better for you than we can and will do.

## THIS TELLS THE STORY.

C. G. ALFORD & Co.,

195 and 197 Broadway,

NEW YORK.

January 17, 1900.

**Connecticut.**

Wilbur H. Gaines has retired from the secretaryship of the Rogers & Hamilton Co., Waterbury.

S. B. McCormack, East Hartford, has moved from Main St. to the Garvin building, Governor St.

W. H. Ely, Middletown, has remodeled his store and made various improvements which adapt it more completely to his growing business.

Frank B. French, of Danbury, will travel through New York State and Pennsylvania in the interests of the Creed-Kellogg Co., jewelers, Boston.

Frank H. Cushing, who has been with the Meriden Silver Plate Co., will have charge of the new glass department when it is removed to the Wilcox Silver Plate Co. shop, Meriden.

The New Haven Clock Co., New Haven, have not completed their inventory and consequently part of the factory is running only eight hours a day. The case department hands are working from 7.30 A. M. until 4.30 P. M. Most of the other employes are working 10 hours a day.

E. R. Blinn, of Cromwell, father of David Blinn, Hartford, died last week after a lengthy illness. The deceased was 70 years of age and a lifelong resident of the town where his death occurred. For several years the deceased was associated with his son in the jewelry business in Hartford.

Word has been received from George M. Curtis, Meriden, who, in company with Mrs. Curtis, has been in Europe for the past two months, to the effect that all hands are enjoying good health. The letter was mailed in southern France. Mr. and Mrs. Curtis are not expected home for at least two more months.

Charles B. Bergen, foreman at the J. D. Bergen Co.'s factory, Meriden, and a brother of J. D. Bergen, will leave the employ of that concern shortly and on Jan. 31 sail on the steamer *St. Louis* for England. Mr. Bergen will start a factory in London for the manufacture of English and American cut glass ware. The concern will be known as the Crystal Glass Works.

Two bills of complaint were filed in the United States District Court, Hartford, Jan. 12 by The L. E. Waterman Co., New York, against Edward W. Button and Harry G. Oliphant, of Bridgeport, who are doing business under the name of E. W. Button & Co. The plaintiffs allege that the Bridgeport firm are selling fountain pens which they claim infringe on their patents.

For the first time since last July the power at the factory of the old Meriden Silver Plate Co., Meriden, was turned on Jan. 10 for other departments beside the glass cutting room, which has been running during the Fall. About 20 employes of the Barbour Silver Co., Hartford, began work there that day, and the balance of the 180 or more employes will be sent to Meriden by March 1.

G. W. French has bought out the jewelry business of A. H. Geck, Ionia, Mich.

WE desire to call the attention of those buying early this season to our large and complete line of guard chains suitable for the lorgnette, watch, fan, muff, purse, or for use as an eye-glass chain, and especially to the many new patterns of chains and slides we are showing. We have borne in mind the tendency toward heavier chains, and are showing some patterns which at this date we believe cannot be duplicated elsewhere.

**B. A. BALLOU & CO.,**  
Providence, R. I.



**DESIGNS, QUALITY, PRICES,**  
Small Profits and Large Sales  
combined have created the  
great demand for the . . .  
**10k. and 14k. Gold Jewelry**  
MANUFACTURED BY  
**HANCOCK, BECKER & CO.,**  
Providence, R. I.  
*SOLD THROUGH JOBBERS ONLY.*



**S. STERNAU & CO.,**  
204 CHURCH STREET, NEW YORK.  
Manufacturers of **METAL WARES**  
in Brass, Copper and Silver.  
**CHAFING DISHES,**  
**KETTLES, TRAYS,**  
Crumb Trays and Scrapers, Bread  
Baskets, Etc.  
CATALOGUE ON APPLICATION.

# TO RETAIL JEWELERS, WARNING

## Keep Tabs on the Tags and Swivels.

When you buy Blackinton Chains the stamps on the swivels tell the story.

EACH TAG AND STAMP ON SWIVEL REPRESENTS A DIFFERENT QUALITY.

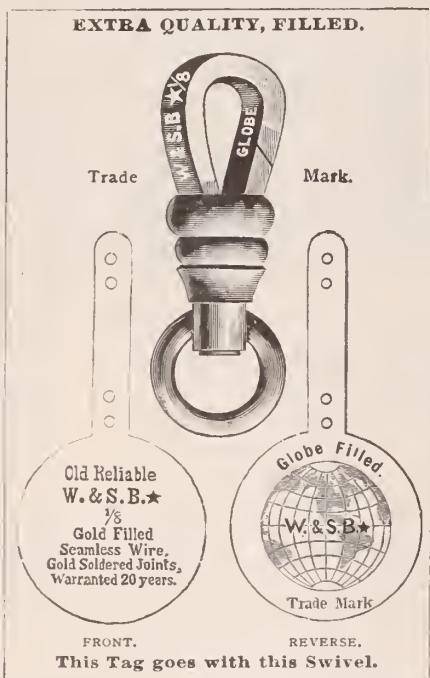

OLD RELIABLE  
**W. & S. B. ★ GLOBE FILLED**  
 ARE EXTRA QUALITY  
 AND WARRANTED TO ASSAY  $\frac{1}{8}$  GOLD.

OUR REGULAR  
**OLD RELIABLE W. & S. B. ★**  
 ARE  $\frac{1}{10}$  PLATE AND SUCH AS WE  
 HAVE MADE FOR 30 YEARS.

IF YOUR SWIVELS BEAR EITHER OF THE ABOVE TWO STAMPS YOU ARE SURE OF GETTING CHAINS THAT EXCEL IN

**QUALITY, DESIGN AND FINISH,**

THE GREATEST OF VIRTUES THAT COMBINE TO MAKE A LINE OF GOODS

**RELIABLE AND SALABLE.**

EVERY JOBBER CARRIES THESE CHAINS. INSIST ON SEEING THEM; A CAREFUL EXAMINATION WILL PROVE THE ABOVE.

Fac





MR. W. SUMNER BLACKINTON EXPLAINING THE DIFFERENT QUALITIES AS INDICATED BY THE STAMP ON THE TAGS AND ON THE GOODS.

QUALITY.



Each Article of this Grade  
is Stamped as above.

THIS IS OUR **2d QUALITY.**

**CAUTION**

Retailers when buying should be most careful to see that chains so stamped are not sold

as either the old reliable W. & S. B. ★ GLOBE FILLED or the old reliable W. & S. B. ★. THIS IS BEING DONE AND HAS BEEN DONE EXTENSIVELY.

SECOND QUALITY.



Trade

Mark.

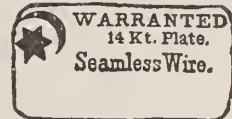

This Tag goes with this Swivel.

Mark.

Reliable.  
& S. B. ★  
Seamless Wire.

with this Swivel.

**W. & S. BLACKINTON.**

Providence, R. I.

New York, 14 Maiden Lane.

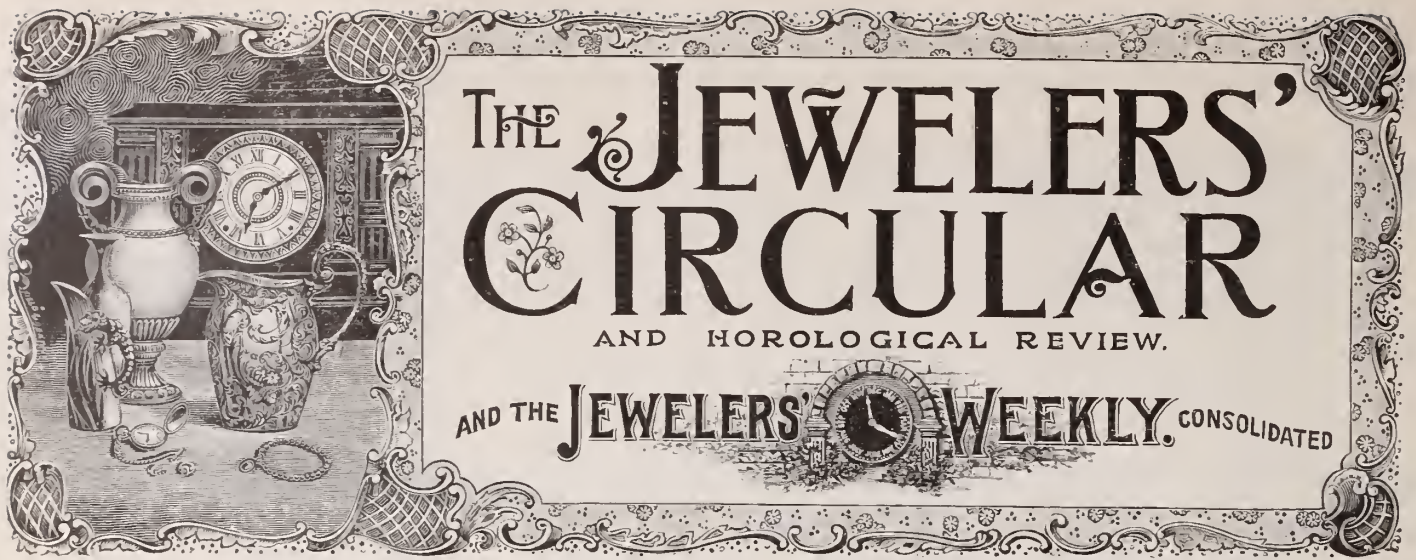

## *Announcement Extraordinary !*

The headpiece above tells a story of great interest to the entire jewelry industry. The story is there plainly told, but some fuller particulars are in order.

During several years past those connected with Jewelry Trade Journalism have become more and more convinced that the trade as a whole demands **ONE GREAT WEEKLY NEWSPAPER** to represent it; to be the chronicler of its happenings and the exponent of its best interests. It was this demand primarily that brought about the plan for the **CONSOLIDATION** of *The Jewelers' Circular* and *The Jewelers' Weekly* into one,

### **“THE JEWELERS' CIRCULAR and THE JEWELERS' WEEKLY CONSOLIDATED.”**

Thus will be merged into one comprehensive journal of the jewelry industry the Oldest Publication in the trade (*The Jewelers' Circular*) and the Oldest Weekly in the trade (*The Jewelers' Weekly*). Thus to the great accumulative influence and prestige of the one, derived from 30 years of unremittent endeavor, of broad, liberal policy, of conscientious study of the trade's interests—this *The Jewelers' Circular*—will be added the prestige obtained by 15 years of equally earnest work on varying lines—*The Jewelers' Weekly*—the sum total representing a measure of usefulness of practically limitless extent.

The uniting of these two journals into one will partake of none of the features of the so-called combine. It contemplates no economies, no curtailments. It will be formed through the will of some of the most expressive minds in the trade, that *one great weekly publication* can best serve the trade; and such a paper “*The Jewelers' Circular and Jewelers' Weekly Consolidated*” will ever be. The uniting of the facilities of the two journals will result in the production of one paper so broad and comprehensive in its scope, so accurate and complete in all its details, so representative of every department of the industry that “*The Jewelers' Circular and The Jewelers' Weekly Consolidated*” will unhesitatingly be universally considered as **THE JOURNALISTIC ORGAN OF THE JEWELRY TRADE**. Such a position each save for the other, has held, but this high place will be fortified and held impregnable for all time to come.

With its extended circulation, its inexhaustible facilities, its accumulated prestige, and last but not least its hearty and responsive endorsement by the trade, “**THE JEWELERS' CIRCULAR and THE JEWELERS' WEEKLY CONSOLIDATED**” will begin the new era of its career with potentialities for usefulness to the jewelry industry that will be exercised to the utmost. *The consolidation will take effect with issue of Jan. 31, 1900.*

**THE JEWELERS' CIRCULAR PUBLISHING COMPANY.**

### **OPINIONS OF THE DAILY PRESS ON THE CONSOLIDATION.**

*Brooklyn (N. Y.) Standard-Union,*  
Jan. 4.

Two of the oldest of the jewelry trade papers, **THE JEWELERS' CIRCULAR** and **THE JEWELERS' WEEKLY**, have consolidated, and the name of the new journal is **THE JEWELERS' CIRCULAR AND THE JEWELERS' WEEKLY**. The publishers announce that there will be no curtailment of their present staffs, and that with their combined efforts they will be able to turn out a larger paper, which will more fittingly represent the jewelry trade. The combination of their interests has been accomplished with the help of the trade, who have long sought this combination.

*Philadelphia (Pa.) Record,* Jan. 4.

**THE JEWELERS' CIRCULAR** and **THE JEWELERS' WEEKLY**, which have been the recognized newspapers of the jewelry trade, have been consolidated and after the last day of this month will be issued as one publication. Both journals have been heretofore published on a rather broad scale, and the issues of each have been very attractive, not only to the trade, but to the general reader, and as it is announced that none of the former features will be discontinued, it is expected that some very attractive numbers will be issued.

*Harrisburg (Pa.) Telegraph,* Jan. 5.

Beginning with the issue of Jan. 31, 1900, **THE JEWELERS' CIRCULAR** and **JEWELERS' WEEKLY**, of New York, two of the leading trade publications of the country, will appear as one publication, the title being **THE JEWELERS' CIRCULAR AND THE JEWELERS' WEEKLY, Consolidated**. **THE JEWELERS' CIRCULAR** is the oldest publication in the trade, and **THE JEWELERS' WEEKLY** the oldest weekly in the trade. Both have been very prosperous and their consolidation means still greater prosperity and a publication of inestimable value to the trade.

## OPINIONS OF THE DAILY PRESS ON THE CONSOLIDATION.

CONTINUED FROM PAGE 30.

### *New York Sun.*

Beginning on Jan. 31, THE JEWELERS' CIRCULAR and THE JEWELERS' WEEKLY, the two oldest papers devoted to the jewelry trade, will appear as one paper, under the title of THE JEWELERS' CIRCULAR and THE JEWELERS' WEEKLY, Consolidated. The papers will be issued separately to-day, and each will contain an announcement of the consolidation, in which it is explained that the merging of the interests of the papers into one publication is the result of a general demand on the part of the trade.

### *New York Tribune.*

For several years past those connected with jewelry trade journalism have become more and more convinced that the trade as a whole demands one great weekly newspaper to represent it. It was this demand primarily that has brought about a plan for the consolidation of THE JEWELERS' CIRCULAR and THE JEWELERS' WEEKLY into one periodical, THE JEWELERS' CIRCULAR and THE JEWELERS' WEEKLY, Consolidated. The former is the oldest publication and the latter the oldest weekly in the trade. It is believed that the union of the facilities of the two journals will result in the production of a paper so representative of every department of the industry that it will be universally considered the journalistic organ of the jewelry trade. The consolidation will take effect with the issue of Jan. 31, 1900.

### *New Haven Journal and Courier.*

The jewelers of this city, as well as of the country at large, will be much interested in the news that the two leading publications in the trade, THE JEWELERS' CIRCULAR and THE JEWELERS' WEEKLY, have just been consolidated, and this week these prominent trade journals will appear in their consolidated form. THE CIRCULAR has for a long period of years held a leading place in this country among high-class trade journals, and THE WEEKLY has also been very prominent. The consolidation of these journals marks an epoch in the history of jewelry trade publications, and this consummation will be welcomed heartily by the jewelry profession, as it predicates the prosperous existence and wide usefulness of a strong and great jewelry newspaper. By this consolidation the oldest publication in the trade, THE JEWELERS' CIRCULAR, and the oldest weekly, THE JEWELERS' WEEKLY, are merged into one powerful journal. By the combination no curtailments nor economies are contemplated, but instead the making of a trade paper that will most fully and comprehensively cover the broad field which the trade presents.

### *Detroit Tribune, Jan. 5.*

Detroit jewelers will be interested in knowing of the consolidation of THE JEWELERS' CIRCULAR and THE JEWELERS' WEEKLY, of New York. The former is the oldest publication in the trade, having been started 30 years ago, while the latter is the oldest weekly, being started 15 years ago. The new paper will be known as THE JEWELERS' CIRCULAR and THE JEWELERS' WEEKLY, Consolidated, and the interests of the trade will be more largely represented, the scope of the new publication being broadened. Both have been models of trade paper journalism. The consolidation will take place Jan. 31.

### *Birmingham (Ala.) News.*

THE JEWELERS' CIRCULAR and THE JEWELERS' WEEKLY, both New York publications, have consolidated, the new arrangement to take effect Jan. 31. This is a combination of two of the oldest trade journals in the country, and brings together potent influences in the advancement of the business of the jewelers.

### *New Haven (Conn.) Register.*

An announcement of more than usual interest and importance to the jewelry and silver ware trade is that of the consolidation of the two best known journals in that trade—THE JEWELERS' CIRCULAR and THE JEWELERS' WEEKLY—taking effect with the issue of Jan. 31, 1900. Both are published in New York City.

Trade journalism to-day occupies a place among the industries of the country that meets requirements little understood by the public generally. In all lines, nowadays, merchants and manufacturers are eager to seize upon the medium which gives reliable news of their particular industry and early special information of a technical character. The value of advance knowledge thus obtained is frequently inestimable. The trade journal is, therefore, a permanent fixture, and to no other trade is it more valuable than to the jewelry and silver ware trade.

THE JEWELERS' WEEKLY and THE JEWELERS' CIRCULAR have occupied the highest round in the ladder of jewelry trade journalism. Both had ministered to their subscribers with rare success and intelligence, but the trend of the past few years has been towards a demand for one comprehensive publication that should chronicle faithfully all trade events of interest and become the exponent of the best interests of the industry and business it represents. This demand is now happily met in the junction of the two great forces—THE JEWELERS' CIRCULAR, standing for the oldest publication, and THE JEWELERS' WEEKLY for the oldest weekly in the trade. The result must necessarily be the production of a journal that will be unhesitatingly looked upon and welcomed by the trade as its foremost and best representative.

### *Meriden (Conn.) Record.*

A consolidation is to be consummated Jan. 31 that will be of great interest to the silver and jewelry trade. On that date THE JEWELERS' CIRCULAR, the oldest publication in the trade, and THE JEWELERS' WEEKLY, the oldest weekly in the trade, will be merged into one. The publishers announce that no economies or curtailments will be made, but the new issue will be greater and better than ever before. It has been determined that one great weekly publication, making a conscientious study of the trade's interests, is demanded, and therefore the consolidation is being perfected.

THE JEWELERS' CIRCULAR and THE JEWELERS' WEEKLY, Consolidated, is the name under which the new paper is to be published, and it is probable it will be accepted as the journalistic organ of the jewelry trade. With its extended circulation and accumulated prestige, it will undoubtedly meet with warranted success.

### *Lancaster (Pa.) New Era.*

A matter of more than ordinary interest to the jewelry trade throughout the country will be the announcement of the proposed consolidation of THE JEWELERS' CIRCULAR and THE JEWELERS' WEEKLY, which consolidation will take effect with the issue of Jan. 31. Each paper has heretofore been, save for the other, the representative trade journal in their line, and the consolidation will result in the publication of a journal that will be, unquestionably, the journalistic organ of the jewelry trade, which trade can congratulate itself on having such an able and accurate exponent.

### *Newark (N. J.) Call.*

Announcement was made last week that the two foremost organs of the jewelry trade, THE JEWELERS' CIRCULAR and THE JEWELERS' WEEKLY had joined their forces, and the consolidated publication will be known as THE JEWELERS' CIRCULAR and THE JEWELERS' WEEKLY, Consolidated.

### *Montreal Daily Witness.*

An event of great importance in the trade journalism of the United States is the contemplated consolidation of THE JEWELERS' CIRCULAR and THE JEWELERS' WEEKLY, of New York. THE CIRCULAR is the oldest publication in the trade and THE WEEKLY is the oldest weekly, and the merging of these two into one comprehensive journal of the jewelry industry will inevitably constitute it the great journalistic organ of the jewelry trade. THE JEWELERS' CIRCULAR and THE JEWELERS' WEEKLY, Consolidated, will be the title of the new organ, and the consolidation will take effect with the issue of Jan. 31. During several years past those connected with jewelry trade journalism have become more and more convinced that the trade as a whole demanded one great weekly newspaper to represent it, and it was this demand primarily that brought about the present plan.

### *Toronto Globe, Jan. 6, 1900.*

The tendency towards consolidation in business interests is affecting journalism as well as commerce. THE JEWELERS' CIRCULAR, of New York, the oldest publication of the trade, and THE JEWELERS' WEEKLY, its energetic rival, have amalgamated, both titles being retained in the order given. This union of forces on the part of journals occupying already first class positions in their special field, will be advantageous from every point of view. The interests of the jewelry trade have a valuable and influential exponent in THE JEWELERS' CIRCULAR and THE JEWELERS' WEEKLY, Consolidated.

### *Halifax (N. S.) Chronicle.*

THE JEWELERS' CIRCULAR, published at New York, and the oldest publication in the trade in America, has consolidated with THE JEWELERS' WEEKLY, the consolidation to take effect with the issue of Jan. 31. THE CIRCULAR has always been considered one of the foremost trade papers issued, and the uniting of these two journals will result in the production of a paper so representative of every department of the industry that it will be looked upon as the journalistic organ of the jewelry trade in America.

### *Jacksonville (Fla.) Evening News.*

Two of the most influential, if not the most influential, of the organs of the jewelry trade are to be combined into one strong trade journal. These publications are THE JEWELERS' CIRCULAR of thirty years' standing and THE JEWELERS' WEEKLY, which has been in existence for fifteen years. Their union will place at the command of jewelers a periodical characterized by a policy of unremitting attention to the best interests of the trade.

### *Jacksonville (Fla.) Times-Union.*

THE JEWELERS' CIRCULAR, the oldest publication in the trade, and THE JEWELERS' WEEKLY, the oldest weekly in the same line, are about to be merged into one broad, comprehensive weekly organ for the jewelers of the United States under the name of THE JEWELERS' CIRCULAR and THE JEWELERS' WEEKLY, Consolidated. The combined publication contemplates no curtailment or economies, but will devote its energies to meet at every point all possible requirements of the jewelry industry.

### *Lancaster (Pa.) Examiner.*

Announcement is made of the proposed consolidation of THE JEWELERS' CIRCULAR and THE JEWELERS' WEEKLY, representative journals of the jewelry trade, the same to take effect with the issue of Jan. 31. The consolidation will result in a publication which will be of great interest and value to the trade.

# A Few Queries for the Jeweler.

**Why not** place in your stock of Silver Ware only those goods that have a **fashionable reputation** with your wealthy patrons?

**Why not** confine your purchases to houses who deal only with Jewelers, thus preserving an exclusive character to the wares in your stock not possible with goods illustrated in Dry Goods Catalogues, and identical with stocks carried by your Department Store competitor?

**Your Silver Wares** are bought for fashionable occasions, and your customers will appreciate your efforts to supply only goods of an exclusive character.

**Sterling Silver Goods sold to Department Stores** should have no place in any first-class Jeweler's stock.

**Sterling Silver Goods illustrated in Dry Goods Catalogues** and circulars are not suited to the fashionable trade.

**Sterling Silver Goods** of an exclusive character are sought for by persons of refinement desiring to make a wedding anniversary or birthday gift.

**Sterling Silver Goods** made by the Gorham Mfg. Co. are sold **only through the Jewelry trade**, and are stamped with the Lion, Anchor and the letter "G," insuring quality.



## Gorham Mfg. Co.,

...SILVERSMITHS...

Broadway and 19th Street, New York City.

BRANCHES:

NEW YORK:  
21 & 23 Maiden Lane.

CHICAGO:  
131-137 Wabash Avenue.

SAN FRANCISCO:  
118-120 Sutter Street.

WORKS: PROVIDENCE, R. I., AND NEW YORK CITY.

# The Jewelers' Circular

AND  
HOROLOGICAL REVIEW.

PUBLISHED EVERY WEDNESDAY BY  
**THE JEWELERS' CIRCULAR PUB'G CO.,**  
CORBIN BUILDING, 11 JOHN ST., COR. BROADWAY,  
NEW YORK.

TELEPHONE:  
1146 CORTLANDT.

CABLE ADDRESS:  
JEWELAR, NEW YORK.

A JOURNAL DEVOTED TO THE INTERESTS OF JEWELERS,  
WATCHMAKERS, SILVERSMITHS, ELECTRO-PLATE MANU-  
FACTURERS, AND ALL ENGAGED IN KINDRED BRANCHES OF  
INDUSTRY.

Member of the American Trade Press Association.

Our editorial columns will contain our own opinions only, and we shall present in other columns only what we consider of interest or value to our readers. Advertising matter will not be printed as news.

Advertising rates in THE CIRCULAR are lower, considering the number of tradesmen reached by its large circulation, than in any other jewelry journal.

Notices of changes in standing advertisements must be received one week in advance; new matter can be received up to Monday.

## INFORMATION FOR SUBSCRIBERS.

### Terms of Subscription, Postage Prepaid.

	PER ANNUM.
United States and Canada, . . . . .	\$2.00
Foreign Countries in Postal Union, . . . . .	4.00
Single Copies, . . . . .	.10

New Subscribers can commence at any time.

Payments for THE CIRCULAR, when sent by mail, should be made in a Post-Office Money Order, Bank Check or Draft, or an Express Money Order or Registered Letter. All postmasters are required to register letters whenever requested to do so.

Pay money only to authorized collectors having proper credentials.

**Returning Copies.** Returning your paper will not enable us to discontinue it, as we cannot find your name on our books unless your address is given.

**Changing Address.** In changing address always give the old as well as the new one. Your name cannot be found on our books unless this is done.

**Discontinuances.** We will continue to send papers until there is a specific order to stop, in connection with which all arrearages must be paid; but such an order can be given at any time, to take effect at or after the expiration of the subscription. All such orders will be promptly acknowledged by mail.

**Liability.** The courts have decided that all subscribers to journals are responsible until arrearages are paid in full and an order to discontinue has been received by the publisher.

### THE JEWELERS' CIRCULAR IN EUROPE.

Among the places in Europe where THE JEWELERS' CIRCULAR is on file are the following:

LONDON—First Ave. Hotel, Holborn, E. C.; Holborn Viaduct Hotel, Royal Hotel.

PARIS—Hotel de L'Athene, Rue Scribe.

LEIPZIG—Handels-Zeitung, für die gesamte Uhren Industrie.

BERLIN—Deutsche Uhrmacher Zeitung, Jager Strasse, 73.

GENEVA—Journal Suisse D'Horlogerie.

AMSTERDAM—Continental Club, Hotel Amstel.

ANTWERP—Diamond Club, Rue de Pelican.

Vol. XXXIX. Jan. 17, 1900. No. 25.

Every line of reading matter in THE JEWELERS' CIRCULAR, with the exception of the few brief extracts from exchanges, always properly credited, is written exclusively for this journal. Each issue of THE JEWELERS' CIRCULAR is copyrighted. Permission to quote is extended to other publications provided such quotations are properly credited.

## An Event and Its Commemoration.

To inaugurate the important event in Jewelry Trade Journalism—the consolidation of THE JEWELERS' CIRCULAR and THE JEWELERS' WEEKLY—it is proposed to make the first amalgamated issue, on the date of Jan. 31, 1900, a

### Consolidation Number.

As a production of up-to-date journalism and artistic achievement, this number will be justly reflective of the occasion it commemorates. To the publishers of this journal this assertion means much. The fulfilling of the obligation thus undertaken is no easy task, but their previous marked successes in this direction warrant them in promising a commemorative number of unusual beauty, originality, interest and enduring value.

### The Use of Gold in the Arts.

AN interesting and important inquiry has been decided upon by Mint Director Roberts with a special view to settling the question whether the official statistics of gold in the country are correct. The estimate, which puts the supply of gold at about \$1,000,000,000 at the present time, has been challenged in many quarters, upon the ground that too large a margin is left for the invisible gold in circulation outside of that in the Treasury and the great banks. The inquiry of Director Roberts is directed to the question of the use of gold in the arts. This use of gold includes its use by dentists, jewelers and manufacturers, in every way except for coin. More than 50,000 persons have been or will be addressed as to the amount of gold thus used during the last year. Previous estimates of the consumption for the arts have put the amount in the United States in the neighborhood of \$12,000,000 a year, but it is possible that the thorough investigation which is now proposed will show a considerably larger use. Reports are regularly received from refineries, but the present investigation will disclose the amount of gold coin which is melted by small manufacturers and jewelers. This probably will not be the limit of the inquiry undertaken by the director. One of the most important questions raised in the recent discussion of the subject has been the amount of gold taken abroad by tourists. The amount transferred on account of letters of credit goes in large blocks and is officially recorded, but it is suspected that the amounts carried in the pockets of travelers for use on shipboard and during the first few days abroad have been underestimated. THE CIRCULAR urges the jewelers to do all they can, as far as they themselves are concerned, to furnish to Director Roberts all figures desired by him to facilitate him in arranging as complete and accurate table as human effort can make it.

antagonistic to the enterprise of hawkers, peddlers, auction promoters and casual merchants generally, who aim to reap harvests in country communities without the payment of the proper license fees. Mr. Percival must pay a fine of \$500, but this sum is given in a good cause, for the decision will stand as a precedent for the guidance of future operators in the same lines, and will bring forth a sigh of relief to the jewelers in their respective districts.

THE CIRCULAR undertakes at all times to answer any query that comes to it, and it takes pride in the fact that its endeavors are crowned with considerable success. But it occasionally receives a poser such as that calling for a list of jewelers who have been located in one town for 50 or more years continuously, received from an esteemed firm some weeks ago. While the compiling of a complete list of such jewelers would prove practically impossible, THE CIRCULAR has ferreted out from its memory a brief list, which is printed on another page. This list will stand, to be augmented by any names that may be supplied from any source. THE CIRCULAR requests the reader who is acquainted with the name of any jeweler entitled to be included in the list to forward such name to this journal.

### Maryland Legislators Have a Sterling Silver Bill Before Them.

BALTIMORE, Md., Jan. 13.—Gen. Latrobe has introduced in the Legislature a bill offered by Charles S. Stieff, of the Baltimore Sterling Silver Co., against the fraudulent marking of silver ware.

The bill is essentially the same as now exists among the statutes of the State of New York, and is designed to go into effect July 1, 1900.

### Foreign Notes.

The German diamond industry is being seriously injured by the South African war. In Hanau four large establishments have been closed.

Wernher, Beit & Co., diamond merchants of London, are reported to have given £50,000 to the fund for the equipment of the yeomanry for service in South Africa.

WITHOUT, perhaps, any intention of doing so, E. P. Percival has rendered a service to the jewelers of the country districts of Pennsylvania for which they ought to thank him. By combatting, successively up to the highest court, the case charging him with violating the State auction law, he has brought out judicial opinion as to the status of the old law—dating back to April 2, 1830—and this opinion is decidedly

## LETTERS TO THE EDITOR.

## 50 YEARS OR LONGER IN THE TRADE.

DETROIT, Mich., Nov. 21, 1899.

Editor of THE JEWELERS' CIRCULAR:

What retail jewelers can you recall who have been continuously in the business, in the town in which they started, for 50 years or more? Our Mr. R. J. F. Roehm commenced to learn his trade here on Dec. 5, 1849, and has been actively engaged in that line ever since, and in this city, excepting three years which he spent in eastern factories perfecting himself in his trade. Thanking you in advance for your information, we remain, yours very respectfully,

ROEHM &amp; SOX.

[This is a hard one. We flatter ourselves that we know a thing or two about the jewelry trade, but to furnish any sort of a complete list of the retail jewelers who have been in business continuously for 50 years in the town in which they started is a task beyond our power to perform. However, we delve out of our memory the following names:

Charles L. Tiffany, New York.  
C. W. Bixler, Easton, Pa.  
Benjamin E. Cook, Northampton, Mass.  
L. L. Mason, Jamestown, N. Y.  
W. S. Taylor, Utica, N. Y.  
H. P. Buckley, New Orleans, La.  
Wm. Bohne, New Orleans, La.  
Henry Silverthorn, Lynchburg, Va.  
W. A. Chamberlin, Towanda, Pa.  
R. J. F. Roehm, Detroit, Mich.

We intend to keep this list standing, and

we would be pleased to swell it with the names of all jewelers who are entitled to be enrolled. Names may be furnished from any source, from the jewelers themselves or from firms or travelers who know such jewelers among their customers and friends.—Ed.]

TOWANDA, Pa., Jan. 4, 1900.

Editor of THE JEWELERS' CIRCULAR:

I see in your last issue that W. S. Taylor, of Utica, N. Y., feels proud of his being in business continuously for 50 years. Now, I am between New York and Buffalo on the Lehigh Valley Railroad, and have been in continuous business 59 years October last, am past 80, and have been well all my life.

WM. A. CHAMBERLIN.

## A CASE FOR THE DISTRICT ATTORNEY.

GOUVERNEUR, N. Y., Jan. 3, 1900.

Editor of THE JEWELERS' CIRCULAR:

I desire to be informed through your valuable paper about this case: A gentleman of this place came in last week to purchase a chain for \$2.50. He picked out the chain and he asked me to give him a blank check on the First National Bank. I supplied him with one and he made out a check, saying that he had only \$1 in his pocket and that I could get my money the next day. When I presented the check at the bank the officials said that it was no good, never was and probably never would be. Since then I have found he played the same trick with some others in this place.

I am willing to spend some money to punish the fellow if it is possible. Do you think I can have him arrested for this or not? Thanking you in advance for your kindness,

Yours very truly,

A. M. FELSON.

[The party referred to is undoubtedly guilty of getting goods under false pretenses, which constitutes a crime under the laws of New York State. It is immaterial where he obtained the blank check. We would advise Mr. Felson to consult with the district attorney of his city.—Ed.]

## A READER OF THE CIRCULAR "ON TO" SNEAK THIEVES' TRICKS.

CUYAHOGA FALLS, O., Jan. 9, 1900.

Editor of THE JEWELERS' CIRCULAR:

Enclosed find article in our local paper about a "pennyweighter," who called on me Dec. 21. He is the same man who was arrested in Williamsport, Pa., as you reported in your issue of Dec. 20, page 12. He had the \$10 gold coin as a watch charm. He visited other stores here trying to sell an atlas. When I got back to the store from my dinner, about 20 minutes after he had been in the store, I went to find him, but he had taken a trolley car for Akron. Mr. Moore [Mr. Phillips's assistant] reads every issue of THE CIRCULAR, and knew at once what this man was after. Yours very truly,

B. F. PHILLIPS.

## THE VALUE OF A TON OF DIAMONDS.

NEW YORK, Jan. 13, 1900.

Editor of THE JEWELERS' CIRCULAR:

There are 151.76 karats to troy ounce; 1,824 karats to the pound. Allowing but 2,000 pounds to the ton (2,000 pounds troy lighter than 2,000 avoirdupois), we find that there would be 3,648,000 karats in a ton, which, at \$40 per karat—a low figure for cut stones—would show a ton of diamonds to equal in value nearly \$145,000,000. Allowing for difference between troy and avoirdupois weights, \$175,000,000 would be nearer the mark. Respectfully submitted,

yours,  
READER.

## Lancaster, Pa.

John Craig, of Canton, O., has accepted a position in the jeweling department of the Hamilton Watch Factory.

E. P. Ledos, of the Ledos Mfg. Co., Newark, N. J., and John Swigart, Cincinnati, O., were in the city on business a few days ago.

The Hamilton Watch Factory was closed only two days to take the annual inventory. The year just ended was the most profitable in the factory's history.

A. Rosenstein, of the Lancaster Silver Plate Co., and Augustus Rhoads were elected members of the Conestoga Fire Insurance Co., organized here Jan. 13.

At the annual meeting of the local board of trade, held on Friday, W. W. Appel and S. Kurtz Zook were elected to membership. At the same time Augustus Rhoads was elected one of the board of directors.

John Kieffer, jeweler, was awakened by police a few nights ago with the startling announcement that burglars were seen entering his house. A search was instituted and it developed a mare's nest, the supposed burglar being a member of the family.

## ON MEMORANDUM

After the Holiday Clean-out



your cases need filling up. We will send you on approval anything you want in Diamonds and Diamond Jewelry to fill up. There's no question that prices will go still higher, so you'll be the gainer if you let us know at once just what you need.

V. WARING, N.Y.

## CROSS &amp; BEGUELIN

Importers and Cutters of Diamonds and Precious Stones

43 Rue de Meslay, PARIS

Telephone, 2188 Corlandt

17 Maiden Lane, NEW YORK

**New York Notes.**

Max J. Lissauer, of Lissauer & Co., has been re-elected a director in the Columbia bank.

H. Blanchard Dominick, of Dominick & Haff, has been re-elected a director of the Second National bank.

L. W. Rubenstein has moved from the ninth to the fourth floor of the Fahys building, 54 Maiden Lane.

Frances R. Appleton, of Robbins & Appleton, has been re-elected a director of the National Park bank.

Anthony Wallach, a retired jeweler, has been re-elected a director in the Importers' and Traders' National bank.

Courtland E. Hastings, of Carter, Hastings & Howe, has been re-elected a director in the Mercantile National bank.

The Eaton & Glover Co., manufacturers of the Eaton-Engle engraving machines, 87 Nassau St., have enlarged their quarters by adding another office to those they already occupied.

The Mauser Mfg. Co., silversmiths, 14 E. 15th St., will open a down town branch, exclusively for wholesale business, early in February. This branch will be situated in the Gill building, 9-13 Maiden Lane and will be in charge of L. B. Cummings.

Geo. J. Cory, the former Chicago manager of the Pairpoint Mfg. Co. and who was later United States Consul at Amsterdam, on Thursday evening addressed the Liberal Club of Brooklyn on the topic of the Dutch in South Africa. It was essentially a pro-Boer argument.

Jas. Baxter, arrested in Montreal in connection with the Ville Marie bank failure, and who, as told in THE CIRCULAR last week, is said to be wanted in this country on a charge of diamond smuggling, was, with his associates, committed by a police magistrate in Montreal Friday to await trial at the next term of Queen's Bench.

Joseph B. Bowden, of J. B. Bowden & Co.; Henry Randel, formerly of Randel, Baremore & Billings, and Thos. W. Adams, of T. W. Adams & Co., are on the board of directors of the Chatham National bank, elected at the annual meeting of the shareholders last week. Geo. M. Hard has been re-elected president of this bank.

T. Zurbrugg Co. have taken a lease of an office at 9-13 Maiden Lane, into which their New York offices, now at 65 Nassau St., will soon be removed. In their new home they will occupy quarters in conjunction with the Philadelphia Watch Case

Co., and the latter concern will hereafter act as the exclusive export agents for the New York Standard Watch Co. The New York Standard Watch Co. will give up their offices in the Corbin building, 11 John St., and their domestic trade hereafter will be carried on from their factory in Jersey City.

C. G. Alford & Co., the well known jobbers, whose offices are now situated in the Western Union building, Dey St. and Broadway, have taken a lease of the entire sixth floor of the Corbin building, 11 John St., into which the quarters of the firm will be transferred May 1. In their new home C. G. Alford & Co. will have one of the largest suites of offices occupied by any firm in the jewelry trade of New York. It will comprise the offices now occupied by Wm. C. Greene & Co., Edw. F. Sanford & Co., C. K. Colby, Pickering & Quintard, the Providence Stock Co., S. & B. Lederer Co. and the office formerly occupied by Moses Adler. The partitions between these offices will be removed, the whole floor being made into one large room, except that part used for the counting department and the private offices of the members of the house.

W. L. Pollack & Co., formerly diamond dealers of 4 and 6 John St., who failed in September, 1896, filed a voluntary petition in bankruptcy in the United States District Court last week. The petition is signed by the three members of the firm. Wm. L. Pollack, Wm. G. Pollack and Samuel Blatt, all of whom give their oc-

cupation at the present time as clerks. According to the schedules filed with the petition the liabilities of the concern are \$49,046.21 and there are no assets. The larger creditors to the amount of \$500 and over are: Louis Strasburger's Son & Co., \$12,108; Eichberg & Co., \$10,194; United States Diamond Cutting & Polishing Co., \$6,531; M. J. Lasar, \$3,898; J. Wertheimer, \$2,082; H. Z. & H. Oppenheimer, \$1,800; Samuel Sondheim, \$2,070; J. Heilbronn & S. Marchand, \$1,625; M. Engelsman, \$1,365; B. H. Davis & Co., \$1,013; S. Konijn & Co., \$926; Kipper, Vogel & Co., \$838 and \$432; Bonner, Rich & Co., \$775; A. Lorsch & Co., \$677; Ehrlich & Sinnock, \$655; Chas. Keller & Co., \$623; Stern Bros. & Co., \$520; Potter & Buffinton, \$496.

An application to revoke the probate of the will of the late Robt. Wilson, who was at one time a well known jeweler of Brooklyn, was made last week to Surrogate Abbott. The application came from John Wilson, a brother of the deceased, and was on the ground that he was not aware of the provisions of the will before it was offered for probate and also that the will was made through undue influence on the part of the other legatees, who are sisters of the applicant and the deceased. The property to be divided is valued at \$90,000 and each of the three legatees receives one-third. The share of John Wilson, however, is to be held in trust, and he objects to this feature of the will. He denied the allegation that this clause was put in ow-

**C. Dorflinger & Sons,**

36 MURRAY STREET,

NEW YORK,

MANUFACTURERS OF

**FINE GLASSWARE,**

desire to establish an agency in Chicago with control of middle west, in connection with some representative house in a kindred line.

1851.

1900.

**THE CHATHAM NATIONAL BANK, NEW YORK.**

CAPITAL STOCK, - - - \$450,000  
 UNDIVIDED PROFITS, - - - 974,518

GEO. M. HARD, President.

H. P. DOREMUS, Cashier.

W. H. STRAWN, Ass't Cashier.

**STERLING SILVER GOODS ONLY**



**FRANK WHITING & CO.**  
**SILVERSMITHS**  
**NORTH ATTLEBORO MASS**  
1128 B'WAY, NEW YORK.  
220 SUTTER ST. SAN FRANCISCO.

**HENRY C. HASKELL,**  
11 Maiden Lane, N. Y.,

has a special department for Jewelry repairing of all kinds. Prompt attention. Prices right. Exclusive Design Plates sent dealers upon request.

**Selwyn Importing & Trading Co.,**  
14 East 17th St., New York.

Novelties in Stag Hooks, Boars' Tusks and Ivory.      Ebony Goods, Cut Brushes for Mounting.

ing to his drinking habits, saying that the charge was utterly without foundation.

Cahn & Hecht, 68 W. Houston St., have dissolved partnership.

The Manhattan Optical Co. have entered a judgment for \$183.41 against J. Knight Holbrook.

Leopold Stern, of Stern Bros. & Co., has been elected a director in the Market and Fulton bank.

Metzger & Loeb, 37 Maiden Lane, have been succeeded by Louis Loeb & Co., who continue business at the same address.

A petition in involuntary bankruptcy was filed last week against the New York China, Glass & Toy Co., who recently assigned as told in the last issue of THE CIRCULAR. Judge Brown, of the United States District Court, Saturday appointed Wm. F. Upson receiver for the company.

Pursuant to an order from the Supreme Court, granted by Judge Andrews Thursday, Purdy Van Vliet, assignee of Louis Combremont, is advertising for creditors to present their claims at his office, 87 Nassau St., on or before March 30. Mr. Combremont, who was a dealer in jewelers' materials and supplies at 45 Maiden Lane, recently assigned for the benefit of his creditors.

The firm of David Kaiser & Co., manufacturers of diamond mountings, 35 Ann St., dissolved Jan. 9 by mutual consent and limitation, John A. Abel retiring from the concern. The other partners, David Kaiser and Fred L. Smith, continue the business under the old firm name without further change. The firm will hereafter be represented in the west by Samuel Bolles and in New York city and the east by Albert H. Pelletreau.

At the regular meeting of the Jewelers' Association and Board of Trade, held Thursday at their offices, the following 15

firms were elected to membership: American Gem Co., Boston, Mass.; Milton P. Bagg, New York; S. H. Castle & Co., Chicago, Ill.; Ingomar Goldsmith & Co., New York; Herman & Co., Chicago, Ill.; Wm. Huger & Co., Newark, N. J.; Kohn & Co., New York; Le Boutillier & Co., New York; Henry Lederer & Bro., Providence, R. I.; A. F. Lowenthal, New York; Marcellus & Pitt, New York; Schwarzkopf & Dorer, Newark, N. J.; Simmons & Paye, Providence, R. I.; Ströbell & Crane, Newark, N. J.; F. H. Wells, Syracuse, N. Y.

A new firm to engage in the manufacture of diamond mountings and fine jewelry formed on Wednesday last under the name of Abel, Luthy & Co., and they have established an office and factory at 64-66 John St. and 107-109 William St. The three members of this concern are John A. Abel, Adolph Luthy and Edward C. Abel, all of whom are well known to the jewelry trade of the United States in connection with the manufacture of fine jewelry. John A. Abel in particular has had a long experience in this business, having been 14 years with the firms of A. Luthy & Co., Lewis, Kaiser & Luthy and David Kaiser & Co., and who withdrew from the last firm Jan. 9. Adolph Luthy is a son of the late A. Luthy, founder of the old firm of A. Luthy & Co. and a member of Lewis, Kaiser & Luthy, the present Mr. Luthy being employed as a designer by these firms for many years. Edward C. Abel, the third partner, was also in the employ of the same firms for several years. Abel, Luthy & Co. will, beside manufacturing artistic jewelry, deal in diamonds, pearls and precious stones. After the firm have gotten into operation John A. Abel will continue his trips among the trade as heretofore.

The Saturday and Sunday Hospital As-

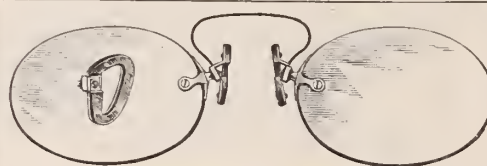

ORDER A SAMPLE  
**GOLF EYEGLASS FRAME,**  
Nickel Plate. For 1 Eye Lenses, 30c.

**IMPERIAL PERISCOPIC Cx,**  
1 Eye Lenses, \$1.00 doz pair.

L. W. LEVY & CO.,

Successors to Levy, Dreyfus & Co. 194 Broadway, New York.

**WM. SMITH & CO.,** GILL BLDG., 9-13 MAIDEN LANE, N. Y.  
ESTABLISHED 1854. 61 PECK ST., PROVIDENCE, R. I.

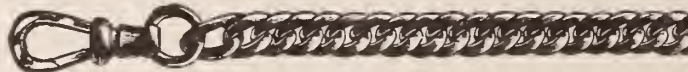

**Gold, Silver and Rolled Plate Chains and Jewelry.**

Novelties in Gold and Silver Bracelets. Also a large line of Chain Trimmings.

WATCHES OF PRECISION.

**MATHEY BROS., MATHEZ & CO.,**

WATCHES DEMAGNETIZED.



MANUFACTURERS AND IMPORTERS OF

Superior Plain and Complicated

**WATCHES AND MOVEMENTS.**

Small Lever Watches a Specialty.



10 SIZE MOVEMENTS. BRASSUS, SWITZERLAND. 21 & 23 MAIDEN LANE, N. Y.

10 SIZE SPLITS.



sociation have appointed C. E. Hastings, of Carter, Hastings & Howe, and Leopold Stern, of Stern Bros. & Co., as a committee to solicit subscriptions in the jewelry trade. It is hoped and believed that in contributing toward this worthy charity the New York jewelers will keep up to their reputation for liberality to institutions of this kind.

Edmund Nebeling has succeeded Nebeling & Hueber, diamond setters, 9 Maiden Lane.

M. Ettinger will hereafter represent Zimmern, Rees & Co., 9 Maiden Lane, through the south and southwest.

H. Michelson, formerly a salesman for I. Michelson, ring manufacturer, 41 John St., has severed his connection with that house and is no longer in its employ.

The first meeting of the creditors of Wm. G. Pollack, Wm. L. Pollack and Samuel Blatt, composing the defunct firm of W. L. Pollack & Co., who last week petitioned bankruptcy, will be held on Jan. 29 at noon, at the office of S. M. Dexter, referee in bankruptcy, 71 Broadway.

The creditors of S. M. Lewis & Co. have been notified by the administrators of the estate of Sylvanus M. Lewis that the estate is insolvent. In a notice sent out by A. A. Baker and Henry P. Lewis, the administrators, they state that J. M. Scott, A. W. Cook and Frederick Hayes have been appointed by the Municipal Court as commissioners of the estate.

A new firm, known as Kent & Woodland, have succeeded to the business of Wm. H. Ball & Co., manufacturing jewelers, 14 John St. The partners are S. B. Kent and A. L. Woodland, both of whom are well known to the jewelry trade. Mr. Kent was for 26 years with Wm. H. Ball & Co., and Mr. Woodland was for many years with Hayden W. Wheeler & Co.

The suit brought by Clara Montague against the Jewelers' and Tradesmen's Co. ended by a judgment signed by Judge McAdam, of the New York Supreme Court, Wednesday. Mrs. Montague was the sole surviving executrix of Henry E. Droz, one of New York's oldest watch importers. Droz was insured in the Jewelers' and Tradesmen's Co. for \$5,000, but after his death and the demand was made by Mrs.

Montague for the money, another claim was put in by one Rachel Flint. The Jewelers' and Tradesmen's Co. had Rachel Flint made a party defendant to the suit brought against them for the amount. The company recently paid the full amount to Ambrose G. Todd, as trustee, and by stipulation it was agreed that Mrs. Montague receive \$4,700 and Mrs. Flint \$300 of this amount. On this stipulation the action against the Jewelers' and Tradesmen's Co. was discontinued and the amount decided on entered into the judgment.

### Last Week's New York Arrivals.

**THE CIRCULAR has perfected arrangements for obtaining the names and hotel addresses of all the latest buyers visiting New York, and each day posts in its office, 11 John St., cor. Broadway, a bulletin which every member of the trade is cordially invited to copy.**

Boston, Mass., H. I. Belcher (Jordan, Marsh & Co.), 8 Greene St.

W. W. Frederick (Posner Bros.), Stuart.

Buffalo, N. Y., A. M. Dueber, Imperial.

Chicago, Ill., C. Bell, Murray Hill.

Cincinnati, O., H. M. Lipman (May & Lipman), Vendome.

C. May (May & Lipman), Vendome.

O. E. Bell, Imperial.

W. B. Thalheimer, Murray Hill.

Middletown, N. Y., J. K. Wiggins, Hoffman House.

Montreal, Can., W. M. Birks, New Amsterdam.

J. A. Pitts, New Amsterdam.

New Haven, Conn., P. P. Wells (Wells & Gunde), Everett.

Pittsburgh, Pa., E. R. Hill (Goddard, Hill & Co.), St. Denis.

C. D. Gillespie, Holland.

A. Kingsbacker, Holland.

A. J. De Roy, Manhattan.

Richmond, Ind., B. J. Bartel (A. H. Bartel & Co.), 61 Leonard.

St. Louis, Mo., A. Kurtzeborn, Imperial.

E. T. Merrick (Merrick, Walsh & Phelps Jewelry Co.), Murray Hill.

S. H. Bauman (Bauman-Massa Jewelry Co.), Imperial.

M. Bauman (L. Bauman Jewelry Co.), Imperial.

Syracuse, N. Y., S. M. Shimberg, Astor.

Toronto, Can., W. J. Barr (Goldsmiths Stock Co.), Astor.

M. C. Ellis, Westminster.

Washington, D. C., R. Castelberg, Imperial.

### The Jewelers' Association and Board of Trade Banquet.

The banquet of the Jewelers' Association and Board of Trade, to be held next Tuesday evening at the Waldorf-Astoria hotel, will undoubtedly realize the most sanguine expectations, in that it will be the most largely attended banquet ever held in the jewelry trade and will be one of the most important ever given by a trade organization. The banquet committee at first decided upon round tables, but owing to the number of applications received for seats, it was found that the ball room of the Waldorf-Astoria, in which the banquet will be held, was not large enough to accommodate the members if seated in this way. Therefore, last week they decided upon putting in long tables instead of the round, which will give them a maximum seating capacity of 440, 10 tables of 44 each, not including the speakers' table.

Up to Monday last the board had received applications for 420 tickets, and it is evident that if more accommodations cannot be obtained, many members may be disappointed in obtaining a place at the banquet. The speakers' committee, under Ludwig Nissen as chairman, have been working diligently to secure the best available speakers, but the names of these speakers will not be given out until the night of the banquet. It is announced that they are men of ability and elocutionary powers, who are thoroughly competent to handle intelligently the important subjects of general interest which have been assigned to them as topics.

## Novelties for Men



TRADE-MARK.

In 14 Kt. Gold, Sterling Silver and  
Ornamented with Jewels.

## Woods & Chatellier,

860 Broadway, N. Y.

42-46 Hill St., Newark, N. J.

## The Standard Trading Corporation

LIMITED,

24 CURSITOR ST., LONDON, E. C.,

SPECIALY ADAPTED FOR PUTTING  
QUANTITIES ON THE MARKET,

Wishes to hear from jewelry manufacturers desiring to increase business and ship to England.

Spot Cash for All Orders.

## \$100 in Gold

is what we offer for the best sample of engraving done on the Eaton-Engle Engraving Machine. If you've got a machine, send in your samples. If you haven't one, write and find out how easily you can get one on installments. You have time enough now to try for this prize, and your chance is as good as anyone's.

It only costs you a penny to send a postal card, and you'll get in return a fully illustrated catalogue, a sample of engraving done on the machine, and any information you may desire regarding it. Drop us a postal card to-day.

## The Eaton & Glover Company,

87 NASSAU STREET,

NEW YORK.

## News Gleanings.

C. A. Clymer has bought out A. E. Vath, Albion, Neb.

H. Koffman, Kansas City, Mo., was last week sued for \$42.

A. Shydecker has removed from Chelsea, Mass., to Woburn, Mass.

Isaac Adler, Butte, Mont., has given a chattel mortgage for \$168.

E. T. King, Lancaster, Tex., has given a deed of trust to creditors.

C. A. Cook has started a silver plating establishment in Zanesville, O.

Grottendick & Kyle, Xenia, O., have been succeeded by Kyle & Tate.

J. H. Wight & Co., Spencer, Ia., have given a realty mortgage for \$600.

C. M. Wendelboe, Logan, Utah, has given a chattel mortgage for \$233.

O. C. Zaumseil, Webb City, Mo., has paid off a realty trust deed for \$1,000.

G. E. Finley, Cottonwood Falls, Kan., has paid off a realty mortgage for \$420.

W. E. Hamlin has purchased the F. B. Cole & Son jewelry stock, O'Neill, Neb.

W. H. Baker has opened a repair shop in E. E. Osborn's store, Montrose, Mich.

The jewelry store of James M. Trester, Ardmore, I. T., has been destroyed by fire.

W. P. Bailey, Onarga, Ill., has removed to another store and increased his jewelry line.

Brown, Hixson & Co. have been succeeded by D. A. Hixson & Co., Lockport, N. Y.

T. Porte & Co., Grand Forks, N. D., have been forced into involuntary bankruptcy.

E. O. Wentworth, of Sanbornville, N. H., has opened a jewelry store in Hartland, Me.

Reynolds & Smelzer, jewelers and general dealers, Greeneville, Tenn., assigned last week.

In a fire in Iowa City, Ia., Jan. 13, among the firms burned out were Price, Keith & Co.

Syman Brothers have purchased the entire jewelry business of Charles H. Leppla, Denver, Col.

G. E. Lacaee has succeeded to the business of F. J. Duplain, Saint Martinsville, La., deceased.

John Gaard, Beloit, Ill., has moved his jewelry stock into his new location in the Solmon block.

Bray & Turner have given a bill of sale on their stock of jewelry, etc., in Bedford, Ia., for \$2,400.

The jewelry and furniture store of W. A. Fezler, Neosho Falls, Kan., has been destroyed by fire.

Louis S. Barney has succeeded to the business of S. A. Barney, Adams, N. Y., who recently died.

H. A. Stone, of the Stone Jewelry Co., Grand Forks, N. D., has filed a voluntary petition in bankruptcy.

J. A. Mosher, Burlington, Kan., has taken his son into the firm, which will now be known as Mosher & Son.

Judson K. Wiggins, jeweler, Middletown, N. Y., and Miss Flora A. Harding were united in marriage last week.

J. G. Martin, Wilkes-Barre, Pa., is clos-

ing out his stock previous to his moving to W. Market St. on April 1.

Chas. J. Brunner has purchased the entire stock and fixtures of the old jewelry firm of J. Warfel & Co., Austin, Tex.

Among the directors of the Union National bank, of Mahanoy City, Pa., elected last week, is E. Schertzinger, jeweler.

J. H. Miles, a former jeweler of Salt Lake City, Utah, has given a chattel mortgage on fixtures which amounted to \$200.

Ratliff & Kloossen have succeeded to the jewelry and hardware business of the old firm of Thriessen & Ratliff, Buhler, Kan.

Charles C. Pettingill, Mound City, Kan., has paid off a chattel mortgage amounting to \$1,082 and has sold out his stock of jewelry.

W. S. Jefflion, Kansas City, Mo., has given a chattel mortgage for \$566 on a stock of jewelry and fixtures, as purchase money.

Albert Mayer, on Jan. 1, was admitted into partnership in the manufacturing jewelry business of Martin Mayer, Mainz, Germany.

Oscar Meyer, a jeweler of Nashville, Tenn., was in Kansas City, Mo., for the purpose of establishing a business there, if he can find a suitable location.

Negotiations are pending with a number of men in Terre Haute, Ind., for the establishment of a wholesale jewelry house in that city with the opening of Spring.

John H. French, jewelers' auctioneer, has just closed a very successful sale for Skillman, Vanderveer & Williams, Trenton, N. J., and commenced a sale on the 10th for George Eakins & Son, Philadelphia, Pa.

William Siegfried, Youngstown, filed a petition in bankruptcy last Friday. Eastern creditors have taken attachments on the stock and will claim it on liens held by them. The assets are given at \$5,500 and the liabilities \$9,000.

Joseph Vetre, jeweler, located in Lewisport, Ky., for the past four months, has fled to parts unknown. He left a board bill for \$50, besides taking several watches belonging to persons who had left them with him for repair.

W. H. Deuble's jewelry store, Canton, was damaged to some extent by fire last Thursday evening. Water and smoke did much more damage than the heat, however, which was confined to some of the other stores adjoining.

E. A. Whipple, Springfield, Mass., who has been in the watchmaking and jewelry business 55 years, has retired from active business, and his store will be conducted in the future by his sons, C. E. Whipple and O. N. Whipple, who have for many years assisted their father in the business. The firm name will be changed to E. A. Whipple & Sons.

C. D. Calhoon has sold out his retail jewelry business in Kingfisher, Okla., and he and his brother, A. Calhoon, formerly engaged in the jewelry business in Shawnee, Okla., have gone to New York to buy a stock of material, and will open a material business. It is understood the location they have selected for their new venture is Kansas City, Mo.

## INDEX TO ADVERTISEMENTS.

Aikin, Lambert & Co.	2
Aikin, Lambert Jewelry Co.	2
Alford, C. G., & Co.	26
American Watch Case Co.	56
American Waltham Watch Co.	20
Arnstein Bros. & Co.	56
Avery & Brown	25
Ballou, B. A., & Co.	27
Bassett Jewelry Co.	2
Bates & Bacon	24
Bell, O. E., Co.	19
Bell Watch Case Co.	22
Bigney, S. O., & Co.	41
Blackinton, W. & S.	28, 29
Bonner & Co.	12
Borgfeldt, Geo., & Co.	52
Bowden, J. B., & Co.	8
Bradley Polytechnic Institute	56
Bryant, M. B., & Co.	24
Carter, Hastings & Howe	9
Chatham National Bank	25
Citroen & Janssens	42
Clark & Coombs	24
Clyde Liue	45
Cross & Beguelin	16, 34
Crossman, Charles S., & Co.	39
Crouch & Fitzgerald	55
Crown and Lion Watch Cases	47
Day, Clark & Co.	24
Deutsch Bros	56
Dorhinger, C., & Sons	35
Dubois Watch Case Co.	45
Dueber-Hampden Co.	15
Eaton & Glover Co.	37
Eisenmann Bros	12
Eliassof Bros. & Co.	24
Esser & Barry	45
Fahys, Jos., & Co.	4
Fairchild & Johnson Co.	56
Field & Beattie	44
Foster, Theodore W., & Bro. Co.	2
Frankel's Sons, Jos.	22
Friedlander, R., L. & M.	56
Fuchs, Ferd., & Bros.	45
Goodfriend Bros	9
Gorham Mfg. Co.	32
Hancock, Becker & Co.	27
Haskell, H. C.	36
Harris & Harrington	56
Hedges, Wm. S., & Co.	8
Hemberger & Lind	55
Hraba, Louis W.	2
Jacot & Son	45
Juergensen, Jules	48
Kahn, L. & M., & Co.	56
Kahn's Sons, James	12
Ketcham & McDougall	45
Knowles, Dr.	45
Knowles, J. B. & S. M., Co.	7
Kohn, Alois, & Co.	56
Lederer, S. & B., Co.	55
Ledos Mfg. Co.	45
Lelong, L., & Bro.	56
Levy, L. W., & Co.	36
Lintz, Jules J.	48
Lorsch, Albert, & Co.	56
Mabie, Todd & Bard	55
Malliet, C. G., & Co.	8
Martin, S.	42
Mathews & Prior	12
Mathey Bros., Mathez & Co.	36
Mauran, John T., Mfg. Co.	43
Mauser Mfg. Co.	25
Mercantile National Bank	18
Meriden Britannia Co.	11
Meriden Gravure Co.	25
Mossberg & Granville Mfg. Co.	21
Mount & Woodhull	8
Myers, S. F., Co.	44
Nissen, Ludwig, & Co.	10
Omega Watches	23
Oppenheimer Bros. & Veith	8
Patek, Philippe & Co.	12
Potter, Wm. K.	25
Reichhelm, E. P., & Co.	56
Reisner, L. C., & Co.	3
Rich, H. M., & Co.	45
Rogers, Wm., Mfg. Co.	44
Roy Watch Case Co.	16
Saunders, John F.	9
Schulz & Rudolph	48
Selwyn Importing & Trading Co.	36
Sherwood, John W., & Co.	14
Simmons, R. F., & Co.	5
Simmons & Paye	45
Simons, Bro. & Co.	45
Smith, Alfred H., & Co.	10
Smith, Wm., & Co.	36
Standard Trading Corporation	37
Sternau, S., & Co.	27
Stern Bros. & Co.	12
Street, Geo. O., & Sons	48
Sussfeld, Lorsch & Co.	42
Towle Mfg. Co.	23
Treibs Bros	44
Valfer, S. & Co.	23
Vrieslander & Moreels	42
Wadsworth, G. F.	42
Waite-Thresher Co.	46
Wallace, R., & Sons Mfg. Co.	42
Weidlich, Wm., & Bro.	48
Westphal, W. C. A.	48
Wheeler, Hayden W., & Co.	13
Whiting, F. M., & Co.	36
Wood, Chas. F., & Co.	56
Wood & Hughes	45
Woods & Chatellier	37

## Special Notices.

Rates 75c. per insertion for notices not exceeding 3 lines (25 words); additional words 2 cents each. If answers are to be forwarded, postage stamps must be enclosed. Two insertions, 15 per cent off; three insertions, 20 per cent off; four insertions or more, 25 per cent off. Payable strictly in advance.

Display cards on this page will be charged at \$2.00 per inch for first insertion, subject to same discount as above for subsequent insertions.

Under the heading of **SITUATIONS WANTED** on this page advertisements will be inserted for One Cent a Word, each insertion, no discount, but no advertisement will be inserted for less than 25 cents. This offer refers to **SITUATIONS WANTED ONLY**. Payable strictly in advance.

In all cases if answers are to be forwarded, 10 cents extra to cover postage must be enclosed.

## Situations Wanted.

**EXPERIENCED TRAVELING SALESMAN** desires position with watch case or jewelry manufacturer; good references. Address, "Traveler," care Jewelers' Circular.

**PRACTICAL DESIGNER**, with 15 years' experience in all branches of sterling silver ware, desires position; All references furnished. Address "Sterling," care Jewelers' Circular.

**SUPERINTENDENT AND DESIGNER** with large experience in all branches of sterling silver ware desires position; best of references. Address "Designer," care Jewelers' Circular.

**WANTED**—A silver or gold line of goods to carry in connection with another through New England and Middle States, on commission. Address, "New England," care Jewelers' Circular.

**WANTED**—Position in wholesale or retail jewelry house by an expert watchmaker of 19 years' experience; best of references from leading watch houses of the trade. B. B., care Jewelers' Circular.

**SITUATION** by competent watchmaker, jewelry repairer, plain engraver and salesman; 20 years' experience; married; wants permanent situation at \$18 per week. Address, "Sober," care Jewelers' Circular.

**TRAVELING SALESMAN**, thoroughly experienced in the jewelry line, desires a position with a good house; young man; single; All references; will work for a low salary on the start. Address, "Salesman," care Jewelers' Circular.

**CATALOGUE MAKER AND ADVERTISER** of many years' experience, with knowledge of the jewelry business, desires to connect himself with good house; understands reaching buyers; highest references. Address, "Arthur," care Jewelers' Circular.

**AN OPTICIAN**, watchmaker and engraver wants a steady position with a good firm; understands the business thoroughly; young man, single, sober and steady; have tools and trial case; state salary in first letter; All references. Address, "Optician," care Jewelers' Circular.

**SIDE LINE**—An experienced and successful salesman now calling on retail jewelers, department stores, etc., in Michigan and Illinois with a line of leather goods wants to add a side line of small goods such as link buttons, brooches, belt buckles, jeweled combs, beauty pins, novelties in plated silver and set goods, medium and cheap grades; a line that can be carried in small trunk or sample case; have established trade and can furnish highest references. Address with full particulars, F. L. H., 1801 Jackson St., Sioux City, Iowa.

## Help Wanted.

**WANTED**—First-class watchmaker; no other need apply; steady employment. Wright, Kay & Co., Detroit, Mich.

**SALESMAN FOR SOUTH**—Experienced man wanted, no other need apply. Averbek & Averbek, 19 Maiden Lane, New York.

**CUT GLASS SALESMAN** wanted to represent a large factory. Answer, stating full particulars, "Cut Glass," care Jewelers' Circular.

**WANTED**—First-class jewelry repairer, stone setter and engraver; one capable of helping with clock work preferred. C. L. Bryant, Danbury, Conn.

**WANTED**—A first-class jeweler and engraver; must come well recommended as to skill and character. Apply to C. F. Greenwood & Bro., Norfolk, Va.

**HELP WANTED**—First-class diamond setter, one who can assist on jewelry repairing preferred; permanent position to right man. B. L., care Jewelers' Circular.

**WANTED**—Two first-class manufacturing jewelers and stone setters; one first-class engraver and jeweler; references required. Geo. Wettstein, manufacturing jeweler, Cedar Rapids, Iowa.

**A FIRM** dealing in American watches and diamonds wants a competent stock clerk; one who is thoroughly posted in American watches. Apply with reference only, A. B., care Jewelers' Circular.

**WANTED**—A bright youth, writing a good hand and familiar with office duties; a good opening for the right party; state reference, age, experience and expectations. X. Y., care Jewelers' Circular.

**WANTED, YOUNG MAN**, 18 years of age; must write good hand and figure well, to assist in office and stock of jobbing house. Address, stating experience and salary desired, F. A., care Jewelers' Circular.

**SALESMAN**—Experienced man wanted for the south to represent an old established gold ring and diamond goods house; only those with established trade need apply. Address, "Manufacturer," care Jewelers' Circular.

**A DIAMOND HOUSE** desires a first-class traveling salesman for the middle west; good salary to the right man; none need apply excepting those commanding a good trade. Address, "Importer," care Jewelers' Circular.

**WANTED**—Young man, 20 to 22 years of age, of good address and ability, as salesman in New York City; one acquainted with the jobbing trade preferred. Apply to Larter, Elcox & Co., 21-23 Maiden Lane, New York.

**SALESMAN WANTED** to carry a moderate-priced gold line on commission in connection with another non-conflicting line, through New York State and the west. Address, R. L., care J. Frank Beers, 607 Broad St., Newark, N. J.

**WATCHMAKER** who is engraver, jeweler, salesman, stockkeeper and all-round helper with tools; steady job; send sample of engraving, and photo; state wages wanted and full particulars. Address, "Jeweler," care Jewelers' Circular.

**WANTED**—Experienced salesmen having an acquaintance with the jewelry and stationery trade, to sell fine line of gold pens, pencils, silver novelties, fountain pens, etc., for the middle western States. Address, Edward Todd & Co., 9 E. 16th St., New York City.

**AFTER JAN. 1**—A first-class manufacturing jeweler and stone setter who can make all kinds of diamond mountings, cluster work, and understands enameling and the use of dynamos for gilding and plating, as foreman in a newly equipped shop with six to eight men; highest salary and permanent position to right man; best of references required. Address, G. O., care Jewelers' Circular.

**WANTED**—FIRST-CLASS SALESMEN to sell on commission to retail trade our celebrated 14k. solid gold filled band rings of our own manufacture; these goods are put up in beautiful and expensive pyramid shape show cases; only experienced salesmen that sell other lines; exclusive right of State given; either \$100 indemnity or cash bond required for samples and faithful performance. Address, Arnstine Bros. & Mier, Cleveland, Ohio.

## Business Opportunities.

**FOR SALE**—Jewelry and optical business; established 10 years; 1,000 inhabitants; reason for selling, poor health. C. R. Sherman, Libertyville, Ill.

**FOR SALE**—An old established and flourishing jewelers' jobbing business at Montreal, Can.; selling out on account of sickness in the family. For particulars address, Private P. O. Box 373, Montreal, Can.

**JEWELRY STOCKS BOUGHT**—Retailers wishing to dispose of surplus or entire stock of diamonds, watches and jewelry can find quick, cash, strictly confidential buyer by addressing S. Marx, 22 Lispenard St., New York City.

**FOR SALE**—No. 7 Emery Arcade, the best jewelry store with fixtures, all complete, in arcade opposite Hotel Emery; bargain. Address, S. B. Duncan, 7 Arcade, Cincinnati, O.

## For Sale.

**FOR SALE CHEAP** Two jewelers' trunks in good condition. Day, Clark & Co., 23 Maiden Lane, New York.

## To Let.

**OFFICE ROOM** to let to nice, quiet firm with us; terms \$25 per month. A. S. Gardner & Co., Room 73, Hays Building, 21 and 23 Maiden Lane.

## LOST.

A liberal reward will be paid for the return of to stone, pink pearl, Lorgnette Chain, lost January 16, 1900.

MARSELLUS & PITT, 11 John St., New York.

## WANTED—DIAMOND SETTER

and Jeweler. Must be a good setter, and able to do hard-soldering and general repairing. First-class wages and permanent position for a good man. Good references required.

HENRY KOHN & SONS,  
890 Main St., Hartford, Conn.

## TO LET, SECOND FLOOR IN DECKER BUILDING,

33 Union Square, New York.

SIZE: 30 x 130 FEET.

Fine Office, Show Room, Room for Polishing in rear. Possession in February.

Apply to **GEO. W. SHIEBLER**  
on premises.

## Seven Maiden Lane.

Floors and Offices to let

in this prominent centre of the jewelry, diamond and silverware trade; modern fireproof building with all conveniences; each office directly lighted and ventilated; possession at once. For full particulars apply to

E. A. CRUIKSHANK & CO., 141 Broadway.

## TO LET

IN THE

## UPTOWN JEWELRY and SILVERWARE DISTRICT,

UNION SQUARE, WEST,

From Feb. 1, for a term of years, No. 19, (second door above Tiffany's), large store, basement, first and second floors; separately if desired. Janitor on premises. Apply to

HORACE W. DAY,

17 STATE STREET, NEW YORK.

TELEPHONE, 724 BROAD.

## CASH OFFERS.

If at any time you have offered to you by your customers any jewelry containing diamonds, pearls or other precious stones, and you do not care to buy them yourself, send them to us and we will submit an IMMEDIATE CASH OFFER. Trade and Bank References if desired. Established 1880. Correspondence solicited.

CHARLES S. CROSSMAN & CO.,  
3 Maiden Lane, New York.

THE PUBLIC WINDOW TAKES ITS WAY

# WESTERN SUPPLEMENT

## THE JEWELERS' CIRCULAR

VOL. XXXIX.

NEW YORK, WEDNESDAY, JANUARY 17, 1900.

No. 25.

### Chicago Notes.

All communications in reference to the Chicago department of *The Jewelers' Circular*, addressed to Stephen Parlin, 1522 Lill Ave. (Telephone, Lake View 397), Chicago, will receive prompt attention.

T. Zurbrugg, of T. Zurbrugg Co., is expected to make a call at the Chicago office of the company this week.

E. J. Hoyer, retail jeweler, 228 N. State St., has recovered from an illness of two weeks' duration, and is again at his store.

Mr. Cohen, St. Paul, was here last week selecting lines for a watch material house he will open there in the Manhattan building.

E. A. Dorrance, of Simons, Bro. & Co., left Thursday week for the factory meeting at Philadelphia, to remain away until February.

Edwin F. Leopold & Co. have opened an office for their novelty jewelry on the eighth floor of the Columbus Memorial building.

James Maque, who has charge of the optical department of Katlinsky & Gatzert Co., has been ill a couple of weeks, and it is feared he will have to undergo a surgical operation.

R. Wallace & Sons Mfg. Co., who have been at 109-111 Wabash Ave. for the past five years, will move March 1 to the ninth floor of the Silversmiths' building, taking the entire floor.

Jno. F. Turner, jewelers' auctioneer, has opened a sale for the Fair & Square Jewelers, Joliet, Ill. The sale will probably be continued all this month.

Judge Kohlsaat Jan. 11 entered an order for the discharge of the indebtedness of Morris Eppenstein & Bro., who were in the jewelry business in Chicago in 1895. Their total debts were \$29,441.

The M. S. Benedict Mfg. Co. are enlarging and fixing over their offices at 109-111 Wabash Ave. New fixtures are being put in which are in bright cherry and give an air of brightness to the rooms. The increasing business of the company has made room at a premium in their quarters, and they have found it necessary to lease the fifth floor of the building, the one above their present quarters, to be used for storage purposes.

The Julius King Optical Co. have secured another room to be added to their salesroom on the eighth floor of the Champlain building. In the last three months the increasing demand on the company has caused them to add three adjoining rooms to their original quarters, an average of

an additional room a month. Under the management of J. T. Brayton the western branch of the company has quite outgrown all previous expectations.

The last work on the jewelers' banquet of 1900 was concluded last week by the appointment of the following reception committee: Mortimer N. Burchard, Herman F. Hahn, Julius Schnering, James B. Caldwell, Albert C. Becken, William J. Miller, Max Ellbogen, William F. Juergens, Moses Loeb and R. C. Demarest. You can't lose yourself with such a committee to welcome the coming guests. Just order your driver to stop at Kinsley's at 7 o'clock Friday evening, Jan. 19, and the committee will do the rest.

There were as many jobbers in town last week looking at factory stocks as there were retail dealers calling on the local jobbers. Among the better known out-of-town jobbers may be mentioned George Wettstein, Cedar Rapids, Ia.; Ben Marx, of D. Marx Sons, St. Paul, Minn.; Jo. Ayres, of T. R. J. Ayres & Sons, Keokuk, Ia.; M. A. Lumbard, Des Moines, Ia. Among the retailers calling on jobbing houses were A. K. Camp, Milwaukee; L. D. Dana, Antigo, Wis.; M. V. Cole, Michigan City, Ind.; Mr. Trask, of Trask & Plain, Aurora, Ill.; August Bruder, Fort Wayne, Ind.; Mr. Shapira, of St. Paul, and Zinn & Voss, Milwaukee, Wis.

Another of those delightful trips to Elgin was enjoyed by a party of Chicagoans last Wednesday, the hosts being Messrs. Franks, Eppenstein and Gubbins, of the Illinois Watch Case Co., and the guests largely from the working force of Benj. Allen & Co. On their arrival at Elgin the visitors were taken on a tour of inspection of the company's plant, and afterward enjoyed lunch at the residence of M. C. Eppenstein, to the accompaniment of a string orchestra, returning to Chicago on the late train, a happy lot. Those who enjoyed the outing were A. H. Goetz, H. A. Farquharson, A. H. Vivian, LeRoy Cram, C. W. Myers, F. L. Murray, John A. Cox, A. M. Church, railway time inspector, Dan Sullivan, the former well known jeweler of Rockford, and the hosts, president Jacob Franks, of the Illinois Watch Case Co., and M. C. Eppenstein, S. C. Eppenstein and George Gubbins, of the company.

A small lamp in the show window of A. G. Bedford's jewelry store, Ionia, Mich., exploded at about 5.30 some evenings ago and set fire to the window trimmings. The blaze was extinguished before it got under headway.

### Cincinnati.

W. H. Bradshaw, Wooster, O., went into bankruptcy last week.

Mrs. Emma Plaut has qualified as administratrix of the estate of the late Bernard Plaut.

Frank Barta, aged 10 years, was arrested at Hamilton, O., last week for stealing several ladies' watches from the jewelry store of Mrs. A. Seidensticker.

C. J. F. Bene, of Bene, Lindenberg & Co., is arranging his affairs so that he may go to Europe after the Spring trade is over. He will stay abroad all Summer.

Richter & Phillips will dissolve partnership on the 15th, Mr. Richter retiring. Ed. Richter, his nephew, who formerly conducted the jewelry department at the Fair, will buy his interest.

Harry Walton, secretary of the Wadsworth Watch Case Co., went out last week to make his usual calls upon the trade through the east. He will carry with him some of the company's Spring specials.

Citroen & Janssens, formerly cutters for the H. Keck Mfg. Co., will open up a diamond cutting and polishing shop at 415 and 417 Race St. on Feb. 1. The shop will be fitted up with every facility to cut diamonds and for recutting and polishing and will solicit repair work from the trade.

It is reported that W. H. Clawson, Minocqua, Wis., has failed. Mr. Clawson wanted \$1,000 worth of goods from Oskamp, Nolting & Co., last month, on credit until Jan. 1. The firm wrote him that if he would give good security they would send on the goods. A canvass among the jobbers in Cincinnati has not disclosed any one caught here.

Thoma Bros., formerly of Piqua, O., successors to A. F. Thoma, importer and jobber of watchmakers' tools, materials and findings, have fully launched their new enterprise in Cincinnati, and have opened at 419 Vine St. Their fixtures are entirely new. Fred Thoma will start out on the road this month for the new house. He is well known as a traveler for the old firm. A. J. Thoma, who formerly represented A. G. Schwab & Bro., will also go on the road after the firm are fully established.

John L. Hamilton, jeweler, Danville, Ill., was called to Cleveland, O., a few days ago by the death of his mother.

The articles of incorporation of the Ottawa Silver Co., Ottawa, Ill., were filed a few days ago. The capital stock is given as \$45,000.

# The S. O. Bigney & Co.'s New Jewelry Plant.

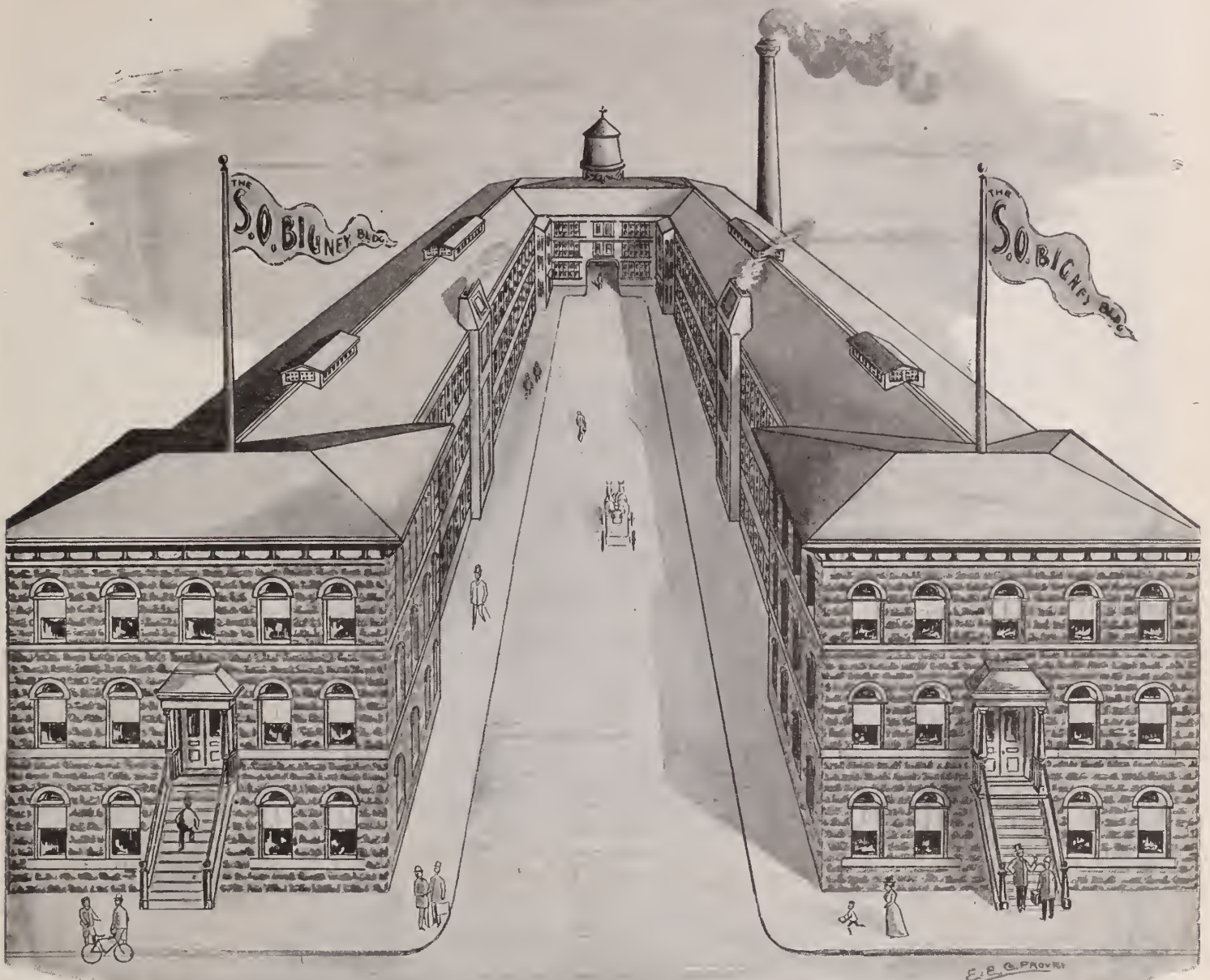

## TO THE JOBBING TRADE OF THE COUNTRY.

ATTLEBORO, MASS., Jan , 1900.

*Gentlemen:*—We take great pleasure in announcing that we are now located in our new plant at Attleboro, the largest and best equipped chain plant in the United States. We take this opportunity to thank the trade for their liberal patronage during the year 1899, which has had much to do in making our house one of the most successful in the jewelry industry. We shall ever strive to please and accommodate our customers in every way. "Promptness" will be our motto from this time forward, and we shall endeavor to ship all duplicate orders within twenty-four and not to exceed thirty-six hours after they reach our factory. Our large space and modern equipment will enable us to accomplish this. We have just one word to say to the retail trade: "Remember that no chain in the world stands higher and gives better satisfaction than our make, and that they are exactly as we represent them. We have three grades, ten, fifteen and twenty year, and every purchaser will get value received. Ask your jobber for these goods, for your stock will not be complete without them."



**S. O. BIGNey & CO., Attleboro, Mass.**

**St. Louis.**

May & Lipman will open a store at 512 Locust St. about Feb. 15, selling bric-à-brac, silver novelties, etc., as specialties.

Among out-of-town jewelers here last week were: C. H. Gieseke, Trenton, Ill.; S. O. Harvell, Litchfield, Ill.; C. D. Gardine, Grand Tower, Ill.

On account of extensive improvements to their new store building A. Kurtzborn & Sons will not be ready for business quite as soon as originally anticipated.

A meeting of the Retail Jewelers' Association of Missouri will be held on

Wednesday, Jan. 17. The annual election of officers will take place in February.

C. H. Hurst, formerly of Corinth, Miss., has accepted a position with T. G. Burkett, Jefferson City, Mo.

Isaac N. Hahn, for many years a traveling representative for the S. A. Rider Jewelry Co., has been promoted to permanent manager of the store. Mr. Hahn's success has been deserved by many years' hard work in the Rider company's interests.

**Detroit.**

The stock of Henry Koester & Co., 106 Woodward Ave., will be sold under a chattel mortgage held by the Home Savings bank on Wednesday, Jan. 17. Bidders from the east are expected to be present.

The suit of F. G. Smith and M. S. Smith against W. A. Sturgeon & Co., recently reorganized, for the value of \$25,000 worth

of stock which they held in the old firm, is being tried before Judge Waite, in the Circuit Court.

**Pittsburgh.**

I. E. Isaacs' has returned from a two weeks' trip east.

J. M. Stoner, Jr., has filed his account as trustee of Geo. W. Biggs & Co.'s estate.

Lewis J. Selezwick has been elected president of the Pittsburgh Jewelry Co. L. C. Goldsoll and M. Rothchild have retired from this firm.

The members of the firm of R. Siedle & Sons, 254 Fifth Ave., are now W. R. and O. C. Siedle, the estate having been settled after the death of Reinhold Siedle.

Grainer Bros., who now occupy the entire floor of the Mellor building, have found this space inadequate and have engaged the third floor for their clock department.

Al. J. De Roy, of Jos. De Roy & Sons, was married to Miss Flora Kuttbauer, of Detroit, at the Hotel Cadillac. A large number of friends and relatives went to Detroit in a special car.

The motion for a new trial in the case of Charles Hoyt, the accomplice in the A. E. Siedle diamond robbery, was overruled by Judge White. Hoyt's attorney, James Francis Burke, then asked permission to argue the case. A date will be set for the argument.

Buyers here last week were: E. F. Preiss, Homestead, Pa.; Abe Teplitz, McKeesport, Pa.; Frank Hayes, Washington, Pa.; H. C. Morrison, Mt. Pleasant, Pa.; Carl Leighner, Butler, Pa.; R. Hays, Morgantown, W. Va.; H. C. Reineman, McKeesport, Pa.; A. Merz, Sewickley, Pa.; John Zugschwert, Carnegie, Pa.; Charles A. Loughman, McKee's Rocks, Pa.; H. H. Weylman, Kittanning, Pa.; A. C. Graul, Sharpsburg, Pa.

With the new year a new jewelry stock company on an extensive scale will be organized under the name of the W. J. Johnston Company. The personnel of the new firm includes W. J. Johnston, now of W. J. Johnston & Co.; H. E. Lineaweaver, Stephen Stone, W. P. Potter and H. H. Ward. The incorporators have applied for a charter to sell goods at wholesale, especially watches, diamonds and jewelry. Messrs. Lineaweaver and Potter are well known attorneys of Pittsburgh.

**G. F. WADSWORTH,**  
Watch Case Manufacturer  
AND REPAIRER.

Everything in the line of Watch Case Repairing. Old English and Swiss Cases changed to take American Stem-wind Movements a specialty.

**OLD CASES MADE NEW.**  
**CHARGES REASONABLE.**  
Silversmiths' Building, CHICAGO.

**CITROEN & JANSSENS,**  
Diamond Cutters and Polishers for the Trade.  
Special attention given to repairing stones.  
415 to 419 Race St., CINCINNATI, OHIO.  
Jewelers' Company Entrance.

The **Wright Fountain Pens** "Write right."

OUR LEADER ASSORTMENT,  
**\$7.50.**

One dozen Wright Fountain Pens, assorted holders, plain, chased, black and mottled, with good size 14K. gold pens, assorted points—fine, medium and coarse. Put up in imitation morocco cartons, with easel back, making nice display.

Send for illustrated catalogue of our complete line.

All makes of Fountain and Gold Pens repaired.

**Wm. Weidlich & Bro.,**  
507-510 Holland Building,  
Distributors **ST. LOUIS.**  
**THE WRIGHT PEN CO.**



**"THE PARAGON OF JEWELRY AUCTIONEERS."**

*Keystone, May, 1899.*  
"Greatest auctioneer in the United States."  
—*Commercial, Vincennes, Ind.*  
"Has captivated bargain seekers all over the country."  
—*St. Joseph Daily Herald.*  
"As an auctioneer he is a 'cracker-jack.'"  
—*Fort Smith, Ark., Times.*

**S. MARTIN,**  
**JEWELRY AUCTIONEER,**  
784 FIRST ST., - - MILWAUKEE, WIS

**Georgian STERLING SILVER.**

In Complete Table Service—



COFFEE SPOON.

French Gray Finish.

**TOWLE MANUFACTURING CO.,**  
CHICAGO. NEWBURYPORT, MASS.



**San Francisco.**

W. F. Holden, traveling representative of Simons, Bro. Co., Philadelphia, Pa., is now making his regular trip through the coast.

B. Lapp, retailer, formerly located on 7th St. and Broadway, Oakland, Cal., has opened a store at 1917 Market St., San Francisco.

Ernest Block, formerly with W. & S. Blackinton, has notified the trade he will be here in a few days as the representative of Louis Stern & Co., Providence, R. I.

B. Frank Cassiday, formerly in the jewelry business at Suisun, Cal., has been made a deputy in the office of John C. Lynch, Collector of Internal Revenue, in this city.

F. H. Carpenter, formerly with R. F. Simmons & Co., is here this week representing Fuller, Carpenter & Co., Providence, R. I. J. A. Limbach, of Theodore W. Foster & Bro. Co., was also booked to arrive here this week.

The Diamond Parlor Jewelry Co. have filed articles of incorporation in this city. The directors are: C. Newman, B. Lees, L. Levin, L. Newman and J. O'Malley, all of San Francisco. The capital stock is placed at \$5,000; subscribed, \$125.

The Daunt brothers, owning retail jewelry establishments in different parts of California, had something of a reunion in this city during the past week. C. A. Daunt and family, of Modesto; F. F. Daunt and family, of Merced, and George Daunt, of Petaluma, were all in town. Each one reported an excellent prospect

for the jewelry business in his respective locality.

**Pacific Coast Notes.**

R. M. Brown has opened a jewelry establishment at Anderson, Cal.

T. R. Newelee has opened a jewelry store in the Heiber building, Redondo, Cal.

N. A. Stephens, San Pedro, Cal., has removed from the Times building to the Clay building.

Miss Bertha Praet and Wilbur E. Blair were married at Woodland, Cal., Jan. 1. The bride is a daughter of Ed Praet, jeweler, of that place.

Burglars made an attempt some time during the storm on New Year's night to rob the jewelry establishment of Herman C. Hotfilter, Sacramento, Cal., but were evidently frightened away.

As a mark of appreciation for his services in apprehending a burglar while in the act of effecting an entrance into his store, Ed Praet, jeweler, Woodland, Cal., has presented to Officer Gwinn a diamond shirt stud.

**Pacific Northwest.**

A. L. Brough has opened a jewelry and repair shop at Puyallup, Wash.

Ullman & Schwander, jewelers, Kalso, B. C., have dissolved, J. J. Ullman retiring.

E. B. Born, Ritzville, Wash., has made some improvements in his place of business.

B. E. Crawford, Oakesdale, Wash., is reported to have discontinued business and gone to Portland, Ore.

F. H. Johnson, McMinnville, has just returned from Vancouver, Wash., where he attended the funeral of his sister.

Oliver Wilson has been in charge of the Wilson jewelry store at Coquille, Ore., during the absence of V. R. Wilson at Myrtle Point.

The stores of Pollock & Warner and C. F. Hurlburt, Junction, Ore., were broken into recently, and the perpetrators helped themselves to jewelry and other valuables in both stores.

W. C. Stull is packing up the remnant of his jewelry stock and storing his fixtures at New Whatcom, Wash., preparatory to leaving for Chicago. He will return to New Whatcom in August or September and reopen his jewelry store.

**Indianapolis.**

E. G. Burlingame has opened a new store at Elkhart, Ind.

M. T. Campbell, Massachusetts Ave., is watch inspector for the Monon railroad.

Gray & Gribben, jewelers, gave a handsome banquet, at the Bates house, Jan. 8, to their 14 employes. A flashlight picture was taken, and each employe will be presented with one of the pictures. The event was in recognition of the faithfulness of the employes.

Will H. Snyder, Niles, Mich., has removed to a more commodious store.

1850

**"BELL-POST" BUTTONS**

1900

WILL NOT BEND OR BREAK.

PATENTED JANUARY 20, 1900.

A NEW LINE FOR A NEW YEAR.

EVERY BUTTON GUARANTEED.

A GUARANTEE BACKED BY 50 YEARS OF SUCCESS.



SOLID GOLD BUTTONS AT POPULAR PRICES.

EVERY PATTERN A WORK OF ART.

FINISH AND WORKMANSHIP UP-TO-DATE.

QUICK SELLERS—RELIABLE GOODS.

**JOHN T. MAURAN MFG. CO.,**

New York Office:

Makers of Gold Jewelry.

Factory:

3 MAIDEN LANE.

PROVIDENCE, R. I.

CONSULT

“The New York Jeweler”

Before Buying Jewelry or Kindred Lines.

For 26 years the acknowledged authority for all that is new, artistic and beautiful in the Jewelry World.



An idea of the assortments illustrated is shown by the fact that there are over 1000 Designs in Diamond Jewelry; 2000 Designs in Watches; 3000 Designs in Emblems; 5000 Designs in Gold and Silver Novelties; and proportionate displays from our Silverware, Clock, Cut Glass, Lamp, Musical, Photographic, Optical, Scientific Instrument, Leather and Fine Stationery Departments.

724 Pages. Size, 9x13.

This profusely illustrated catalogue enables the dealer to make a better selection than the majority of travelers' stocks affords.

S. F. MYERS CO.,

MANUFACTURING and WHOLESALE JEWELERS

Myers Building, 48-50 Maiden Lane, New York.

Mention Dept. G 12 when sending for catalogue.

A GOOD REPUTATION

is a wonderful help in selling an article of merchandise easily and profitably. The reputation of silver-plated ware with this imprint



MAKES IT EASY TO SELL.

The public have learned by experience that goods bearing the "Anchor" mark are of reliable quality and that their use will prove satisfactory. The U. S. Government has designated the "Rogers Anchor Brand" as the standard of quality and durability.

Send for Catalogues.

INTERNATIONAL SILVER CO.,

SUCCESSOR TO

WM. ROGERS MFG. CO.,

HARTFORD, CONN.

New York Warerooms: 9-11-13 Maiden Lane.

Important Meeting of the Optical Society of the City of New York.

The regular monthly meeting of the Optical Society of the City of New York was held, as usual, Wednesday afternoon, in parlor D R of the Fifth Avenue Hotel, and was one of the most important of the year, inasmuch as the officers for 1900 were then elected. The meeting began as is customary at 8.40 o'clock, with a lecture by Prof. Fox, who took for his subject "The Refraction of Light by Prisms," explaining both mathematically and by drawings the meaning and application of the laws of and the methods for finding the index of refraction. The lecture ended amid the usual applause, and was then followed by one on practical optics by Prof. Ferguson, whose subject was "Muscles and the Use of Prisms by Opticians." This lecture was received with great interest and was also roundly applauded. Then commenced the business session.

After the reading of the minutes Chairman Kahn, of the auditing committee, read his report, which showed the society to be in a healthy financial condition. The membership committee received the name of Louis Gotthold, of New York, as applicant, and the society then elected Geo. Mayerle, of San Francisco, to membership. The election of officers followed, these gentlemen being unanimously chosen: President, P. A. Dilworth; first vice-president, F. G. W. Coates; second vice-president, Leo Lewis; financial secretary, Arthur Forth; secretary, M. H. Harris, and treasurer, F. A. Woll. The executive committee elected consist of L. L. Ferguson, chairman; F. B. Marchant, L. Kahn, A. Wiener and J. J. Mackeown.

The new president, Mr. Dilworth, was escorted to the chair by two members, and in a few appropriate remarks thanked the society for the honor conferred upon him. In the course of his speech he laid stress upon the work done for the society by the former president, L. L. Ferguson, and attributed its success both scientifically and numerically to the former president's untiring energy and work in the society's behalf. At President Dilworth's suggestion a motion was made to the effect that a committee be appointed to draft suitable resolutions commending Mr. Ferguson for the able manner in which he had discharged his duties as president. This was unanimously carried, and the following

committee were appointed: L. Kahn, F. A. Woll and M. H. Harris. On the motion of A. Jay Cross a vote of thanks was extended to the outgoing officers for the able way in which they had discharged



P. A. DILWORTH,

PRES.-ELECT, OPTICAL SOCIETY OF THE CITY OF NEW YORK.

their duties during the past year, after which the usual bills were ordered paid, and the meeting adjourned until next month.

Moline Merchants Elect a Jeweler as their Leader.

MOLINE, Ill., Jan. 12.—At the annual meeting of the Retail Merchants' Association a few evenings ago officers were elected.

J. F. Lindvall, jeweler, was elected president; Ed. Coryn, vice-president; Jesse Cowley, secretary; S. S. Hoffman, treasurer. A board of directors composed of one member from each ward in the city were elected as follows: J. H. Efflandt, Fred Sundeen, F. W. Rank, L. R. Gaylord, Alois Tollenaere, H. R. Albrecht.

The subject of premiums was taken up and after a long discussion it was decided unanimously not to offer any premiums during the year.

A NEW METHOD

IN MAKING

Travelers' Watch and Ring Trays

ENABLES US TO PRODUCE THE

STRONGEST TRAY EVER MADE.

Guaranteed for One Year.

FOR FULL INFORMATION, WRITE OR CALL.

S. VALFER & CO.,

Manufacturers of FINE CASES AND TRAYS for Jewelry and Silverware,

33 MAIDEN LANE, NEW YORK.

"Engravings Attract Where Type Is Unnoticed."





**SOUVENIR SPOONS**

We are up to the cash buyer. If you are a cash buyer, you must have our special circular on souvenir coffee spoons for cash buyers. We won't give you time, but we will give you price. No jeweler can afford to be without this circular, nor neglect to give us a chance to quote prices in the way of souvenir spoons or souvenir novelties. We have everything in this line.

**SIMMONS & PAYE,**  
"The Souvenir House,"  
129 Eddy Street, Providence, R. I.

**DR. KNOWLES'**  
...PRIVATE COURSE IN...  
**Optometry.**

SPECIAL RATES IN THE  
CORRESPONDENCE DEPARTMENT.

**"EYE DEFECTS,"**  
A New Book, in cloth, Price, \$1.00.

For terms and important particulars, write to  
**R. H. KNOWLES, M. D.,**  
11 John Street, New York.

**SIMONS BROS. & CO.**  
ESTABLISHED 1840  
TRADE-MARK

PHILA. NEW YORK CHICAGO  
SILVERSMITHS, JEWELERS.  
MAKERS OF GOLD AND SILVER THIMBLES.

**FERD. FUCHS & BROS.,**  
**SILVERSMITHS,**  
MAKERS OF STERLING SILVERWARE,  
34 East 29th St., - New York

**WOOD & HUGHES,**  
Sterling Silverware Manufacturers,  
FINE PLATED WARE,  
No. 24 John Street, - New York.

**H. M. RICH & CO.,**  
Jewelry - Auctioneers,  
7 and 9 Franklin St.,  
BOSTON, MASS.

**JACOT & SON, IMPORTERS,**  
**STELLA AND IDEAL**  
**MUSIC BOXES.**  
89 UNION SQUARE, - N. Y.

**THE LEDOS MFG. CO.,**  
MANUFACTURERS OF  
**Watch Case Materials,**  
Crowns, Pendants, Bows, Solders,  
Springs, Findings, Etc.,  
34-36 PEARL ST., NEWARK, N. J.

**KETCHAM & McDOUGALL,**

MANUFACTURERS OF  
**GOLD AND SILVER**  
**THIMBLES**



No. 149

ESTABLISHED 1832.



TRADE-MARK.



Pat'd Nov. 30, '94

And the improved  
**Automatic Eye-Glass Reel.**

SEND FOR  
CATALOGUE C.

**37 MAIDEN LANE, NEW YORK.**

**Our Hand-made Cases**

are constructed in the old reliable way, which is a pride to the Manufacturer, Dealer and Wearer.

STAMPED. STAMPED.

TRADE MARK ALL CASES BEARING THIS MARK, TRADE MARK  
ARE HAND-MADE.

18 K. 14 K.

Manufactured by **DUBOIS WATCH CASE CO.,**  
Makers of **SOLID GOLD CASES.**

21 and 23 Maiden Lane, New York.

**CLYDELINE**

**To FLORIDA**  
ONLY DIRECT WATER ROUTE BETWEEN  
NEW YORK, CHARLESTON & JACKSONVILLE  
WITHOUT CHANGE

SUPERB PASSENGER SERVICE	SAILING FROM PIER 45 N.R. NEW YORK	THREE SAILINGS WEEKLY
--------------------------------	--	-----------------------------

WM P. CLYDE & CO., General Agents.  
Theo. C. Eber, TRAFFIC MANAGER. 5 BOWLING GREEN, NEW YORK

**ESSER & BARRY,** Largest Manufacturers of  
... Cheap and Medium Priced  
**IMITATION DIAMOND JEWELRY**  
IN AMERICA.

Write us for samples of almost anything with an Imitation Diamond in it.  
MAIN OFFICE AND FACTORY, 101 SABIN ST., PROVIDENCE, R. I.

**WATCH CASE GUARANTEES.**

THE RETAIL JEWELERS SPEAK OUT AND GIVE THEIR IDEAS ON AN IMPORTANT MATTER BEARING UPON THEIR TRADE.

[This series of letters began in issue of Nov. 15.]

It was upon the request of several responsible jewelers that THE CIRCULAR entered upon the undertaking of obtaining a consensus of opinion from the retail trade regarding the guaranteeing of gold filled watch cases, and sent to a large number of jewelers, indiscriminately, a letter of which the following is a copy:

NEW YORK, Sept. 8, 1899.

WE ARE SENDING THIS LETTER TO THE RETAIL TRADE WITH THE OBJECT OF GETTING THEIR VIEWS ON AN IMPORTANT SUBJECT, NAMELY: THE GUARANTEEING OF FILLED WATCH CASES. FROM THE RESPONSES RECEIVED MAY BE EVOLVED SOME VALUABLE SUGGESTIONS.

OF THE FOLLOWING FORMS OF GUARANTEE, WHICH DO YOU CONSIDER MOST JUST, AND WHAT ARE YOUR ARGUMENTS ON THE SUBJECT?

1. SHOULD THE MANUFACTURER GIVE A NEW CASE OF THE SAME GUARANTEE IN EXCHANGE FOR THE OLD CASE THAT HAS NOT LIVED UP TO ITS GUARANTEE?
2. SHOULD THE MANUFACTURER EXCHANGE THE CASE THAT HAS NOT

LIVED UP TO ITS GUARANTEE WITH ONE OF LOWER GUARANTEE? THAT IS, IF A 20-YEAR CASE HAS BECOME DEFECTIVE AT THE END OF 10 YEARS, SHOULD IT BE REPLACED WITH A 10-YEAR CASE?

3. SHOULD THE MANUFACTURER REPAIR THE CASE AND PUT IT IN CONDITION TO OUTLIVE THE UNEXPIRED TERM, IF THE CASE SHOWS THE BASE METAL BEFORE THE LIFE OF THE GUARANTEE HAS EXPIRED?

4. SHOULD HE GIVE A NEW CASE AND CHARGE FOR THE LENGTH OF TIME THE CASE THAT DID NOT LIVE UP TO ITS GUARANTEE HAS BEEN WORN; IN OTHER WORDS, REBATE FOR THE UNEXPIRED TERM OF GUARANTEE?

YOURS VERY TRULY,  
THE JEWELERS' CIRCULAR PUB. CO.

All those jewelers who did not receive this letter are cordially invited to send their views upon this subject, replying to the questions seriatim or collectively. Their replies will receive the same measure of consideration as those received direct from the letters themselves. The more views on this subject expressed by the trade at large the more convincing will be the conclusions reached.

[Tenth series of replies.]

YORK, Pa., Jan. 11, 1900.

Editor of THE JEWELERS' CIRCULAR:

In answer to your inquiries as regards the guarantee of gold filled watch cases, I see only one just way out of the difficulty, and that is for the manufacturer to give a new case of the same quality as the defective case that has not come up to the requirement of the guarantee. This would stimulate manufacturers to make better cases. To do otherwise would be putting a premium on dishonest manufactures and the cases would get still poorer.

If a guarantee means anything it means what it stipulates or else better have no guarantee.

Yours respectfully  
R. F. POLACK.

HASTINGS, Neb., Jan. 5, 1900.

Editor of THE JEWELERS' CIRCULAR:

In regard to guarantee on filled cases, I would say I am in favor of first proposition. I think it is the only fair proposition to all parties concerned. I sent a case to a supposed reliable manufacturer, and he wanted to charge me for the time it had been worn. I left the case with him and gave my customer a different make case. I surely will buy no more of that manufacturer's goods.

Yours,  
O. C. ZINN.

LANCASTER, Pa., Jan. 6, 1900.

Editor of THE JEWELERS' CIRCULAR:

The manufacturers should answer the questions. I for one would accept no case different from the one sold. The retailer's reputation is at stake with every filled case sold. The only trouble I have had with case manufacturers is the long delay when I have had occasion to return a case. Invariably it takes from four to eight weeks to make the guarantee good. The customer looks to us retailers to make the exchange at once. We cannot do it, as we are not sure what the case company will do for us.

Ask the manufacturers why. Or let them print in every case put on the market: "Should this case not live up to the limit of this guarantee we will, if returned to us, replace this case with a new one within two months." It would help the sale. The whole trouble lies in the guar-

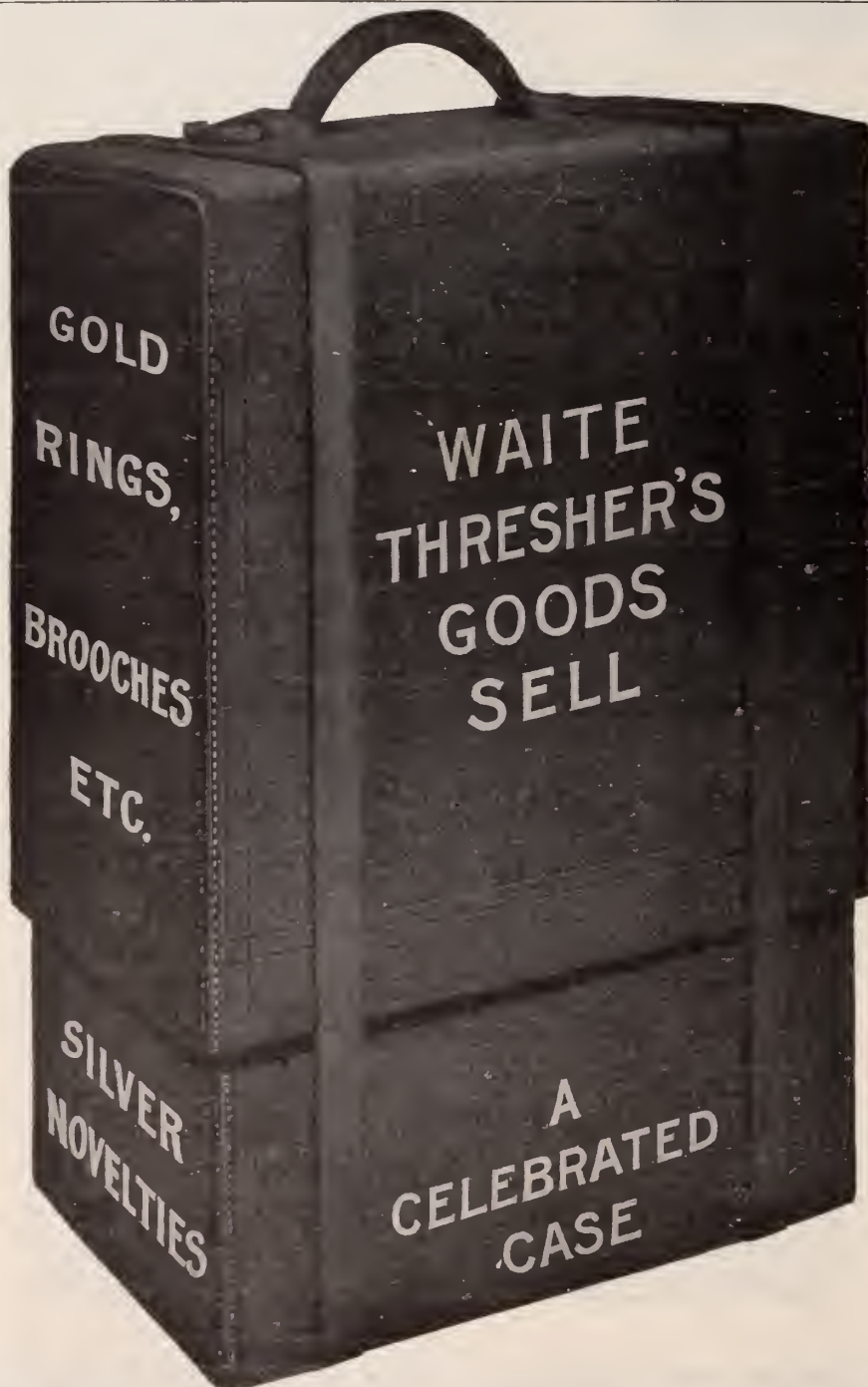

Remember that Articles Purchased from Samples Shown from the Above Celebrated Case are Quick Sellers at Popular Prices.

NEW YORK OFFICE, 11 John Street.

antee which is the best filled part of the majority of so-called filled cases. Let them make cases—not how cheap, but how good.  
Yours truly,  
W. W. APPEL.

EMPORIA, Kan. Jan. 8, 1900.

Editor of THE JEWELERS' CIRCULAR:

Keep up the filled case agitation. In our opinion the filled case will not wear as guaranteed, and some day the jewelers will hold the sack, with the companies busted or sold out.

If any agitation will make them make better cases keep it up. Yours, etc.,  
S. F. RICKER & SON.

ROCHESTER, Minn., Jan. 8, 1900.

Editor of THE JEWELERS' CIRCULAR:

If a case does not stand its guarantee the manufacturers should give another as good or even better. Let them make better goods and charge more. It will be more satisfactory to all concerned. Retailers should sell what will be made right.

Yours truly,  
J. B. BLICKLE.

MARION, O., Jan. 8, 1900.

Editor of THE JEWELERS' CIRCULAR:

We note with interest the discussion in your paper concerning the guarantee on watch cases.

To do justice to all concerned we think the manufacturers have a right to either repair case or replace with one that will wear the unexpired part of the guarantee, but of the same quality of gold.

We do not like the idea of charging any difference between the old and the new case. We have returned cases to four dif-

ferent manufacturers and have found them reasonable. Yours very truly,  
KEELER BROS.

CAIRO, Ill., Sept. 21, 1899.

Editor of THE JEWELERS' CIRCULAR:

In reply to your questions will say:

1. We want a good, honest filled case like those made 20 years ago.

2. No. The manufacturer should give a case that will wear 20 years. That is what the customer paid for.

There is only *one* guarantee for us: To sell an honest case that we know will wear 20 years, as it did 20 years ago.

Yours,  
CHAS. F. MILLER.

FREEPORT, Ill., Sept. 23, 1899.

Editor of THE JEWELERS' CIRCULAR:

In reply to your recent letter we would make this suggestion:

As it does not seem fair for the manufacturer to replace a case that has worn 10 years, for instance, and give a 20-year guarantee with the new one, why could not the watch case company have some cases for exchange purposes which have been left blank of a guarantee? Then, if a 20-year case comes in which has worn off in 12 years, for instance, let the exchange case be stamped with an 8-year guarantee and sent to the customer to fill out the unexpired term of original guarantee. This would seem to us to be fair both to maker and customer.

We also think the owner of the case returned should pay the express charges to the jeweler through whom the exchange is made. Yours respectfully,  
A. W. FORD & SON.

(Series of letters to be continued.)

The Latest Patents.

ISSUE OF JAN. 9, 1900.

640,826. PENHOLDER. FRANK T. STEVENS, Long Lake, Minn. Filed Jan. 23, 1899. Serial No. 703,041. (No model.)

640,844. PROCESS OF ENAMELING. CHARLES H. WATERMAN, Pompton Plains, N. J. Filed June 16, 1899. Serial No. 720,815. (No specimens.)

640,866. MANUFACTURE OF SEAMLESS WIRE. FREDERICK E. BODMAN, Attleborough, Mass. Filed June 14, 1899. Serial No. 720,457. (No specimens.)



640,938. OPERA-GLASS SHUTTER. JAMES W. PATTERSON, New York, N. Y. Filed Nov. 19, 1898. Serial No. 696,896. (No model.)

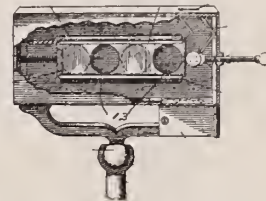

641,024. CIGAR-TIP CUTTER. SIGMUND L. LEDERER, Providence, R. I. Filed June 3, 1898. Serial No. 682,443. (No model.)

In a cigar-tip cutter, the combination with the two parts *a* and *b* forming a receptacle in which the tip end of the cigar is enclosed when cut off, the overlapping curved plates *f f*, the cutters *f' f'*, the beads *d d*, and the oblique edges *e e* on their upper ends, of the bar *g* forming the pivotal con-



Warranted for 25 Years.



Trade-Mark.

YOUR REPUTATION

is worth more to you now than ever before. WHY RISK IT by handling Watch Cases of doubtful merit? Buy reliable goods—they cost no more.

CROWN 14 K.

and LION 10 K.



Trade Mark.

Filled Cases have been established trade favorites for years. There's profit and satisfaction in handling them and **NO RISK.**

The guarantees are reliable and the manufacturers are ready and willing to make good every obligation to the jeweler or his customer.

ASK TO SEE THE NEW 1900 STYLES.

FOR SALE BY ALL JOBBERS.



Warranted for 20 Years.

nection of the two parts, the coiled spring *h* extending around the bar *g*, the ends bearing on the two parts, and the stirrup *i* provided with the ring *f*; whereby the device may be suspended from a chain and operated to cut the end of a cigar.



**641,053. HOLDER FOR EYEGLASSES, Etc.** EDWIN P. TIRRELL, Boston, Mass., assignor of one-half to John D. Crosby, same place. Filed Sept. 25, 1899. Serial No. 731,946. (No model.)



**641,057. COLLAR-BUTTON.** THOMAS WHALEY, Florence, Colo. Filed Sept. 27, 1899. Serial No. 731,812. (No model.)



A cover for the base-plate of a collar-button, comprising the hollow disk-shaped member made of elastic material having an imperforate cushion *E*, the upper wall of said member being thin and having an elongated aperture therein, the parallel ribs *F* on either side of said aperture.

**641,173. MICROMETER-CALIPERS.** JOHN P. B. WELLS, Athol, Mass. Filed March 24, 1899. Serial No. 710,346. (No model.)

**DESIGN 32,078. BADGE.** JAMES C. DERBY,

Concord, N. H. Filed Dec. 6, 1899. Serial No. 739,443. Term of patent 14 years.



**DESIGN 32,079. RING OR SIMILAR ARTICLE.** MARTIN GEBHARDT, New York, N. Y.



Filed Dec. 6, 1899. Serial No. 739,451. Term of patent 7 years.  
**DESIGN 32,080. LINK-BAR FOR CUFF-BUTTONS.** CHARLES H. ALLEN, Attleborough,



Mass., assignor to Charles H. Allen & Co., same place. Filed Dec. 13, 1899. Serial No. 740,225. Term of patent 14 years.  
**DESIGN 32,081. SHOE FOR COLLAR-BUTTONS.** THERON I. SMITH, North Attlebor-



TONS. THERON I. SMITH, North Attlebor-

ough, Mass., assignor to T. I. Smith & Co., same place. Filed Dec. 13, 1899. Serial No. 740,226. Term of patent 7 years.  
**DESIGN 32,082. SPOON, FORK OR KNIFE HANDLE.** CARL C. SCHMIDT, St. John,



Can. Filed Dec. 12, 1899. Serial No. 740,129. Term of patent 3½ years.

**EXPIRED PATENTS.**

[Recently expired patents of interest to the jewelry trade. Reported especially for THE JEWELERS' CIRCULAR by R. W. Bishop, Patent Attorney, 728 Fifth St., N. E., Washington, D. C., who will furnish complete copies of patents at the rate of 10 cents each.]

[Issued Jan. 9, 1883.]

- 270,296. LOCKET.** T. W. FOSTER, Providence, R. I.
- 270,329. TIME-GLOBE.** SAMUEL MOORE and G. A. HADLEY, Providence, R. I.
- 270,400. ALARM-CLOCK.** H. J. DAVIES, Brooklyn, N. Y.
- 270,533. ELECTRICAL CONTROL FOR PENDULUM CLOCKS.** R. W. WILLSON, New Haven, Conn., assignor to the Standard Time Co., same place.  
[Designs issued Jan. 10, 1893, for 7 years.]
- 22,108. BADGE.** ISAAC BEDICHIMER, Philadelphia, Pa.
- 22,125. CLOCK-CASE.** A. O. JENNINGS, Southport, assignor to the New Haven Clock Co., New Haven, Conn.  
[Design issued July 7, 1896, for 3½ years.]
- 25,752. BADGE.** A. B. ELLISON, St. Louis, Mo.

**JULES JÜRGENSEN,**  
COPENHAGEN,

Plain and Complicated **WATCHES AND CHRONOMETERS,**  
Are the leading production of their kind in the world.

SOLE AGENTS  
**Schulz & Rudolph,**  
*Importers and Cutters of Diamonds  
and Other Precious Stones.....*

**28 JOHN and 65 NASSAU ST., NEW YORK.**

**JULES J. LINTZ,**  
**Watch and Chronometer Maker**  
FOR THE TRADE.  
Two Diplomas and First Prizes for Scientific Workmanship.  
**108 Fulton Street, New York.**  
Telephone, 1108 John. DOWNING BLDG., Room 1019.  
Repairing of Fine and Complicated Watches Pocket and Marine Chronometers.  
All kinds of New Pieces made to order and adjusted.  
Correspondence in French, German, Spanish and Italian.

**W. C. A. WESTPHAL,**  
WATCHMAKER,  
41 Maiden Lane, NEW YORK.  
Established 1892. Telephone, 3684 Cortlandt.  
Estimates, Repairing, Adjusting of Chronometers, all Complicated Watches and Fine Time Pieces.  
**DEMAGNETIZING.**  
Watches made Non-Magnetic.  
Fine Wheel and Pinion Cutting

**THE TRUE BLUE**  
Beaded Label Watch Glasses,  
MADE IN  
**FRANCE.**  
ASK YOUR JOBBER FOR THEM.  
**SUSSFELD, LORSCH & CO.,**  
21 Rue de L'Echiquier, PARIS.  
LORSCH BUILDING,  
37 & 39 Maiden Lane, NEW YORK.



**WATCH GLASSES**

BEAR THE  
BEADED LABEL.  
BEWARE OF  
IMITATIONS.  
THE GENUINE  
ARE LABELED

**FRANCE.**



**PRACTICAL COURSE IN ADJUSTING.**

**COMPRISING**

*a review of the laws governing the motion of the balance and balance spring in watches and chronometers, and application of the principles deduced therefrom in the correction of variations of rate arising from want of isochronism, change of position and variation of temperature.*

**ELUCIDATED AND DEMONSTRATED BY**

*original experimental researches in the actual problem, never before published, showing the causes that are operative in the variation of rate and leading to correct remedies.*

**BY THEO. GRIBI.**

Copyright by Theo. Gribi; assigned to THE JEWELERS' CIRCULAR PUB. CO.

[COMMENCED IN ISSUE OF FEB. 1, 1899. PART XXV.]

**CHAPTER IV.**

*(Continuation of Mechanical Effects.)*

**TABLE 12.**

*Showing length and thickness of mainsprings to given number of turns and diameters of the barrel.*

No. of turns the barrel will wind.			5½		6		6½		7	
No. of coils in spring when down.			10.7		11.6		12.5		13.4	
Diameter of barrel.	Diameter of arbor.	Width of coils when "down."	Length.		Length.		Length.		Length.	
			Thickness.	Thickness.	Thickness.	Thickness.	Thickness.	Thickness.		
10.	3.3	1.23	295	0.115	319	0.106	344	0.090	369	0.092
11.	3.7	1.35	324	0.126	351	0.117	378	0.108	406	0.101
12.	4.	1.48	354	0.138	383	0.127	413	0.118	442	0.110
13.	4.3	1.60	383	0.149	415	0.138	447	0.128	479	0.120
14.	4.7	1.72	413	0.161	447	0.149	482	0.138	516	0.129
15.	5.	1.84	442	0.172	479	0.159	516	0.148	553	0.138
16.	5.3	1.97	472	0.184	511	0.170	551	0.158	590	0.147
17.	5.7	2.09	501	0.195	543	0.180	585	0.167	627	0.156
18.	6.	2.21	531	0.207	575	0.191	619	0.177	664	0.165
19.	6.3	2.34	560	0.218	607	0.202	654	0.187	700	0.175
20.	6.7	2.46	590	0.230	639	0.212	688	0.197	737	0.184
Quantity by which the diam. of the arbor must be diminished to obtain one more turn. d=diam. of arbor.			0.138d.		0.126d.		0.116d.		0.108d.	

It is important that we should know the exact length and thickness of a spring necessary to obtain a given number of turns of the barrel; or that we should be able to tell the maximum number of turns a given spring will furnish in a given barrel. For this purpose I have compiled Table No. 12, from an article by L. A. Grosclaude, published in the "Journal Suisse d'Horlogerie," Vol. III. The quantities in the table are applicable to any system of measurement, but the most convenient is the metric system, with the millimeter as unit. The table is calculated on the basis that the diameter of the arbor should be one-third that of the barrel, and that the area the spring occupies should be equal to the area of the empty space. A trial or two of calculation by approximation will show the latter to be equal to the area comprised in a zone inside around the barrel wall of the width of nearly one-eighth of the diameter of the barrel. This is the width of space the spring occupies when it is run down, which is represented by the quantities in the third vertical column. The table scarcely needs any further explanation. Suppose, for instance, that the length and thickness of a spring are required for a barrel whose diameter is 16 millimeters, and which is to give 6 turns: In the column headed by the figure 6 and opposite the figure 16 in the first vertical column, we find

$$\begin{aligned} \text{Length} &= 511. \text{ millimeters} \\ \text{Thickness} &= 0.17 \end{aligned}$$

at the same time, in the second horizontal line over the top of the table, prefixed by "Nos. of coils, etc.," and directly under the figure 6, we find the figure 11.6; this is the least number of coils the spring can have, when "down," in order to give 6 turns of the barrel. The number of coils necessary, if memorized, in connection with the number of turns required, is convenient as a means for readily finding the necessary thickness of a spring without the table; for all we have to do is to divide the inside diameter by 8, and the quotient again by the number of coils necessary, and we have its thickness. It is not necessary to measure the length of a spring exactly when putting in a new one, for, having chosen one of the right thickness, all we have to do is to slip it into the barrel, before making the hole to see whether it has the right number of coils, and to break off its length until it has that number.

The workman should provide himself with good measuring instruments if he wants to profit by the use of the table. The Denison gauge can be of no help, as no two of them measure alike, and its scale is an arbitrary one.

It may be advisable, or it is possible, at least in certain cases, where it is desired to increase the number of turns of the barrel, to diminish the diameter of the arbor a trifle. For this purpose I have added the bottom horizontal line of figures, by which the diameter of the arbor is to be multiplied; the product will be the quantity by which the arbor is to be diminished to produce one more turn of the barrel. It may be well to add, however, that the





1900

# Import Season.

1900



Our exhibition of samples for the coming season will comprise a much wider and more comprehensive variety than we have heretofore shown. Selections will be included from the choicest products of every maker in the European centres, representing everything that is novel, serviceable, and best adapted in style and value for sale in the American market.

As a result of sending our buyers to the different districts much earlier than is customary, and the ability to pay cash for all purchases, we were fortunate in anticipating an advance in prices, brought about by the increased cost of raw material of every character, which is very gratifying as affording us the unlooked-for opportunity of being able to offer most of our wares on the basis of the old scale of prices.

The output of the factories represented by us has also been very materially increased, thus enabling us to enlarge in several of our departments and to these a number of new and important lines have been lately added, which we feel very confident must command your attention.

Our samples are already arriving, but the European manufacturers have experienced a busy and prosperous season, lately, with orders for home consumption that are still in process of execution, so that we hardly expect our lines will be quite complete before the last days of January or the first of February.

It will surely pay you to look through our new collection before placing orders elsewhere.

Respectfully,

## Geo. Borgfeldt & Co.,

West Fourth, Third and Wooster Sts.,  
NEW YORK.

OUR MOTTO:  
"IT PAYS TO IMPORT."

China.  
Bric-à-brac.  
Italian Marbles.  
Bronzes.  
Clocks.  
Parisian Novelties.  
Artistic Pottery.  
China Paintings.  
Pictures.

American Cut Glass.  
Onyx Pedestals.  
Mirror Platteaux.  
Vernis Martin  
Cabinets.  
Antique Brass.  
Antique Lamps.  
Venetian Iron.





## THE RAMBLER'S NOTES.

WHAT THE RAMBLER SAW AND HEARD AMONG THE DEALERS IN ART POTTERY, CUT GLASS, BRONZES, ETC.

**C. L. DWEN-GER, 35. Park Place, New York,** who is now opening his samples for the import trade, has just put upon his counters many new decorations in Royal Bonn pottery. The usual variety of vases, urns and similar articles are to be found in large and small sizes, and the most prominent new decorations appear to be large and bright colored flower designs, ornamenting a body color of either shaded black and dark green, or shaded green and red. In the new bisque figures which this house has also opened are to be found a host of novel and pleasing subjects, particularly in the very small pieces, and on these are darker and more pronounced colorings than in any of his former lines of this character.

AMONG the first of the French china importers to open their import samples for this season are Bawo & Dotter, who are now displaying at their ware-rooms, 32 Barclay St., New York, the latest productions in their Elite china. One of the most notable features among the decorations on the new china is the continuation of the band effects, so popular last year and which now appear with floral designs in larger size and brighter colors than heretofore. Among the prettiest patterns recently opened are the new lily-of-the-valley effects, the white cherry blossoms on a green background, and a third consisting of masses of roses. An entirely new shape has been introduced in the dinner ware, although few, if any, new forms are to be found among the china novelties. This firm are now making a special drive on fine pieces in American terra cotta, which may already be seen in great variety.

IMPORT SAMPLES IN FRENCH CHINA.

REAL BRONZE REPRODUCTIONS OF ANTIQUE SUBJECTS.

OWING to the success attained the latter part of last season by their line of real bronze reproductions of antique subjects, Harris & Harrington, importers, 32

Vesey St., New York, decided to continue this line during the Spring and make a number of additions thereto in both subjects and finishes. Their new lines, which will be opened this week, will, therefore, show pieces taken from celebrated and ancient statuary, in several sizes, from miniatures to large figures, and among the finishes in which they will appear will be green bronze, acid or antique and smoked finish. Some of the most popular pieces in the smaller sizes have been the figure of Venus de Milo, the Dancing Faun of Naples, Achilles, Hector, Faun with Cymbals, Diana, and some modern figures such as the celebrated figure of Napoleon engrossed in thought.

THE RAMBLER.

### Antique Goblets and Drinking Vessels.

(Continued from issue of Jan. 10.)

OF leathern vessels, the most famous was the "Black Jack," so called because it resembled a jack, or coat of mail or leather. Akin to this, though more capacious, was the "Bombard," deriving its name from the huge piece of ordnance so called. References to both of these are frequently to be met with in the literature of the 17th century. Thus Grumio, in the "Taming of the Shrew," says to Curtis, "Be the jacks fair within, the jills fair without." And again, in the first part of "Henry IV.," Prince Hal describes Falstaff as that "swoln parcel of dropsies, that hugh bumbard of sack;" and in the "Tempest" a black cloud is likened to a "foul bumbard that would shed his liquor." In the "Philocthonista" of Heywood, the dramatist, we read that "small jacks wee have in many alehouses of the cite and suburbs tipt with silver, besides the great black jacks and bombards at the court, which, when the Frenchmen first saw, they reported at their returne into their country that the Englishmen used to drink out of their boots." Bishop Hall in his "Satires" speaks of "charging whole boots-full to their friends' welfare;" and, indeed, it is on record that actual boots have been employed as drinking vessels. Marshal Bassompierre, who was sent on an embassy to Switzerland in 1625, drank to his friend's health in one of his military boots before returning, ordinary cups being too small for the occasion. Once, too, it was considered a mark of gallantry to toast a fair lady from her shoe. In the song of "Sir John Barleycorn"—an allegory of

the grain of barley, which the farmer, the maltster, the miller and the brewer are bent on destroying—we read that

"Some of them fought in a black jack,  
Some of them in a can;  
But the chiefest in a black pot,  
Like a worthy alderman."

The rim of the black jack was often of silver, and occasionally gilt, and decorated with little bells. A test of sobriety, therefore, came to be to drink from one of these vessels or jingle-boxes without producing a tinkling.

The word tankard as applied to drinking vessels occurs for the first time in the latter half of the 16th century, and later on we find many examples of tall tankards of ornate design. The most common and familiar article in the cottage of former days was the jug or pitcher of earthenware, often with a set-of doggerel rhymes around its rim. One such mug of the peculiar putty-like color so frequently imitated since bears an inscription telling us that—

"This is Thomas Coxé's cup.  
Come, my friends, and drink it up.  
Good news is come'n, the bells do ring,  
And here's a health to Prussia's king."

Another large mug of the famous Fulham brown stoneware is of the year 1740, and is inscribed with the legend "Walter Vaughan, of Hereford. His mugg, must not be brock!" The beautiful glaze and polish which is a feature of the best pottery of the kind is due to the presence of salt in vapor in the kiln. The earliest notices of stoneware jars in England occur in the first half of the 16th century, and we hear of many with silver covers and neck-mounts at that period, the jugs themselves being probably imported from Cologne. These old drinking vessels are now very rare and fetch high prices, three stone jugs from the Santiforth collection being sold in 1889 for over three hundred and fifty pounds; while a good specimen of the year 1560, though of small size, realized 71 pounds in 1890.

Antique glass is the latest fashion, and the Waterford glass is the special quest of the collector. This glass is pale green in color and beautifully cut and ornamented. Jugs and wine glasses of this kind are very artistic in effect. Mr. Rider Haggard has a great fancy for antique glass—not a piece of glass appears on his dinner table unless it boasts a pedigree.—*Pottery Gazette.*

## MATTERS IN JEWELRY STOREKEEPING.

That this department shall prove mutually beneficial to our readers, it is desirable that the members of the trade generally communicate with THE CIRCULAR regarding any advantageous device or plan that they are utilizing in connection with their business.

### Best Dressed Windows Among the Retail Jewelers.

#### Series II. No. XVI.

*NOTE:—We inaugurated with the issue of May 3, 1899, the second series of characteristic retail jewelers' windows. The first series consisted of illustrations and descriptions of more than 100 different displays, extending over a period of 8 years. We desire any jeweler who thinks his window is interesting or calculated to serve as a lesson to his brother jewelers, to send to us a photograph of such window for illustration under this department.*



THE CHRISTMAS WINDOW OF PENROSE MYERS, GETTYSBURG, PA.

WHILE the picture here shown does not evince any notable originality in the art of window dressing, the window was really far more attractive than any photograph could show. The display was that made during the holiday season by Penrose Myers, Gettysburg, Pa. The window was trimmed with curtains as a back ground, red silk on the bottom, and with festoons of green plants. The surrounding pyramids and small shelves surmounting them were covered with white silk entwined with greens. The center shelf in front was a five-pointed star in shape; to the left was a Maltese cross shelf, to the right a shield shelf, while the remaining shelves were square and hexagonal. The shelves contained watches, small articles of jewelry and silver ware, with watch chains suspended from the festoons. Artistically arranged at the bottom of the window and around the base of the pyramids were silver ware and novelties of all kinds.

#### Revolving Jeweler's Christmas Display.

FOR a number of days crowds collected in front of Culp & Co.'s jewel-

ry store, Boise, Idaho, to look at the ingenious window display arranged by Mr. Culp. It was a revolving platform laden with sparkling pieces from the Culp stock.

## PRIZE ESSAYS

—ON—

### JEWELRY STORE KEEPING.

*The Jewelers' Circular*, continuing its policy to offer from time to time, prizes for essays on matters connected with the conducting of a retail jewelry business, inaugurates a forthcoming series by offering the following nominal

#### PRIZES FOR SUBJECTS.

**Prize \$5.00**—For title of Best Topic for competition on any matter connected with the running of a jewelry store.

**Prize \$3.00**—For title of Next Best Topic.

For each title of the Next Five Best Topics, a year's subscription to THE JEWELERS' CIRCULAR.

Competitors may send in as many TITLES OF TOPICS FOR COMPETITION as they desire, but only one will be selected for the prize competition; that is, no competitor can win more than one prize.

[All Topics must be in by Jan. 28.]

In the center was a Christmas tree, around which circled, in the opposite direction from the movement of the platform, a band holding a number of figures, representing the carolings of children around the popular tree of the season. Mr. Culp says he has a patent on this form of display.

#### Jewelers' Ideas and Schemes.

Roser & Co., Wellington, Kan., issued as a holiday souvenir a pretty embossed folder, containing the birth-month gem poem.

Castelberg's National Jewelry Co., Washington, D. C., placed in the issue of Dec. 14, of the *Washington Evening Star*, what is claimed to be the largest jewelry ad. that has ever appeared in any American newspaper. It covered two pages.

One of the most unique signs in Birmingham, Ala., has just been put in by the Birmingham Optical Co. It is a big pair of eyeglasses, around the bows and bends of which bristle incandescent electric lights. The sign stands about seven feet in height.

#### THE WATCHMAKER.

A WATCH will tell the time of day,  
Or tell it nearly, anyway,  
Excepting when it's overwound,  
Or when you drop it on the ground.

If any of your watches stop,  
We hasten to Mr. Cogs's shop,  
For though he scolds us he pretends  
He's quite among our special friends.

He fits a dice-box in his eye,  
And takes a long and thoughtful spy,  
And prods the wheels and says, "Dear, dear,  
More carelessness, I greatly fear."

And then he lays the dice-box down  
And frowns a most prodigious frown;  
But if we ask him what's the time  
He'll make his good repeater chime.  
—From "The Book of Shops."



Our New Samples are ready for the Spring Trade.  
"ACME"  
Lever Collar, Link and Sleeve Button.

STANDARD OF THE WORLD.

Manufactured in an Endless Variety of New and Original Designs.

We have made large additions to our already handsome and extensive lines in:

CHAINS, RINGS, LOCKETS, CHARMS, BRACELETS AND EMBLEMS.

See our line of EIFFEL PONY, FOB and DICKENS CHAINS.

Hearts, Ornaments, Medallions, Amulets and Tablets.



NEW SAMPLES OF NOVELTIES IN

Drop us a postal and our salesman will call. We sell the Jobbing Trade only.



New York Office,  
11 John Street.

S. & B. LEDERER CO.  
FACTORY, PROVIDENCE, R. I.

Chicago Office,  
131 Wabash Avenue.

THE SWAN FOUNTAIN PEN.

Reputation World Wide.  
Made upon Distinct Principles.  
Is a Compressed Air Pump.  
Simply Wet the Insides to Provoke  
an Energy.

W. W. Stewart, Inventor and Patentee.

A variety of Styles and Prices

- 3 Sizes Safety Swans.
- 3 Sizes Self-filling Swans.
- 3 Sizes Adjustable Feed Swans.

MABIE, TODD & BARD,  
NEW YORK AND LONDON.

CROUCH & FITZGERALD,

Jewelry Trunks  
and Cases,  
161

Broadway,  
Bet. Cortlandt and  
Liberty Sts.

688 B'way,  
723 6th Av.  
NEW YORK.



Push-Grit-Energy.

A long time ago we concluded that the only way to succeed was  
by practicing Push, showing Grit and never diminishing Energy.  
The result is shown in our

1900 Line of Jewelers' Findings

THEY INCLUDE

TUBE SETTINGS FOR COMBS, EBONY MOUNTS, PATENT  
CLUSTER SETTINGS.

MEDALLION HEADS

FOR BROOCH PINS, BELT BUCKLES, LINK BUTTONS, ETC.

Large Scrolls for Picture Decorations and everything in  
Findings for the Manufacturer.

HEIMBERGER & LIND,

158 PINE ST., METCALF BUILDING, PROVIDENCE, R. I.

"BY USING OUR GOODS, YOUR GOODS WILL SELL."

# CHAS. F. WOOD & CO., DIAMONDS

1 MAIDEN LANE, NEW YORK.

IMPORTERS AND CUTTERS.

## DIAMONDS.

LARGE ASSORTMENTS.

DESIRABLE SIZES.

ATTRACTIVE PRICES.

**R., L. & M. FRIEDLANDER,**

30 MAIDEN LANE, N. Y.

97 HATTON GARDEN, LONDON.

## HALL CLOCKS,

*Mantel Clocks,  
Traveling  
Clocks,  
Clock Sets,  
Regulators,  
Bronzes,  
Vases, Ivory  
Miniatures  
and Art Goods.*



Fall Line Now Ready.

**Harris & Harrington,**

32 and 34 VESEY ST., NEW YORK.

Sole Agents to the Trade for J. J. Elliott & Co., London.

American

Watch Case Co.

**A.W.C.CO**

Have Merit—Superiority—Reputation.

9 to 13 Maiden Lane, New York.

## HOROLOGICAL DEPARTMENT,

BRADLEY POLYTECHNIC INSTITUTE,

PEORIA, ILLINOIS.

Largest and best watch school in America. We teach Watch Work, Jewelry, Engraving, Clock Work, Optics. (Formerly Parsons' Horological Institute.) Catalogue Free.



GOLD AND SILVER PENCILS,  
PENHOLDERS, &c.



FAIRCHILD & JOHNSON CO.

Office and Factory,  
220 FOURTH AVENUE, N. Y.

### TO BLOW EFFECTIVELY IS AN ART

which we never practice personally; but we have invented a machine which does it for us, called the

"Reichhelm Pressure Blower."

This, with Gas Furnaces and Jewelers' Tools generally, is the stock in trade of

E. P. REICHELHM & CO.,  
23 JOHN STREET, NEW YORK CITY.

## L. LELONG & BRO.,

Gold and Silver

Southwest Corner of  
HALSEY and MARSHALL STREETS.

REFINERS,

NEWARK, N. J.

ASSAYERS and

Sweepings a Specialty.

SWEEP SMELTERS.

ALOIS KOHN & CO., 4 MAIDEN LANE, SOLID GOLD CHAINS,  
Near Broadway, N. Y.

We call the attention of the Trade throughout the country to our line of

### LOGNETTE AND GUARD CHAINS.

Will send Samples on Memorandum on receipt of satisfactory reference. Correspondence Solicited.



DEITSCH BROS.,

14 East 17th St.,  
New York.

LEATHER.  
EBONY,

SHELL,  
IVORY.

ALBERT LORSCH.

TELEPHONE CALL, 746 CORTLANDT, N. Y.

ALFRED KROWER

## ALBERT LORSCH & Co.,

LORSCH BUILDING,  
37 & 39 MAIDEN LANE, N. Y.,

167 WEYBOSSET ST.,  
PROVIDENCE, R. I.

IN STOCK, A LARGE ASSORTMENT OF

# PEARLS

ALL SIZES AND  
QUALITIES.

SEE ANNOUNCEMENT ON PAGE 30.

IMPORTERS AND CUTTERS OF DIAMONDS  
 65 NASSAU ST. NEW YORK.  
 Cor. John.  
**Arnstein Bros. & Co.**

DIAMONDS and Cutters.  
**L. & M. KAHN & Co.,**  
 172 Broadway,  
 Cor. Maiden Lane, N. Y.  
 DIAMONDS

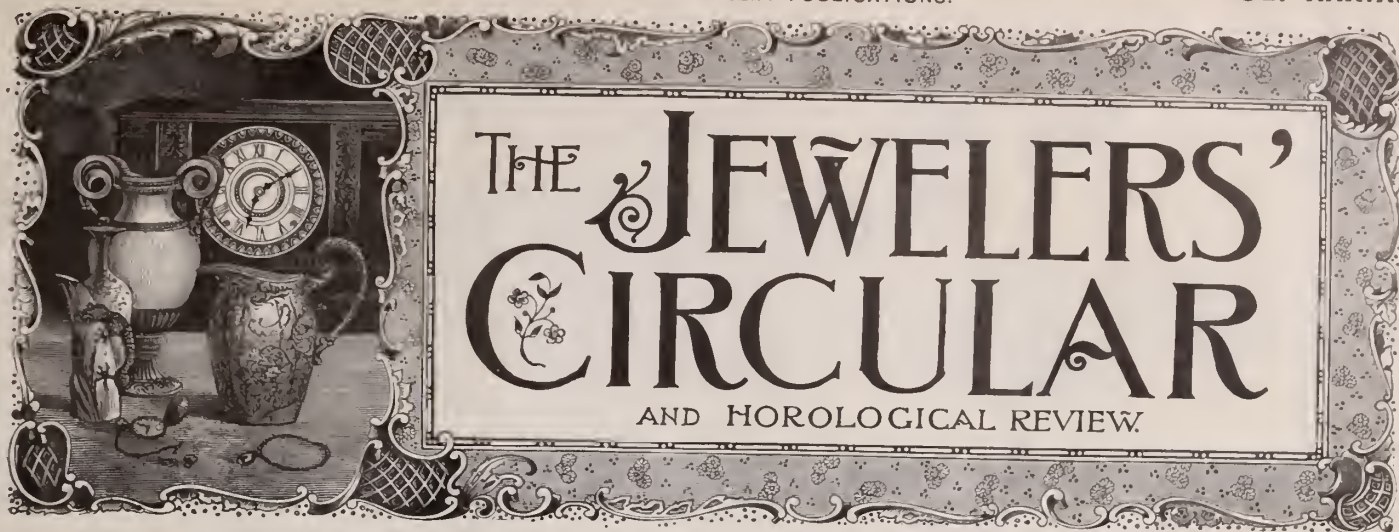

Corbin Building, 11 John St., Corner Broadway, New York.

Copyrighted by THE JEWELERS' CIRCULAR PUB. Co., 1900.

Entered at the Post Office in N. Y. as second-class matter.

VOL. XXXIX.

NEW YORK, WEDNESDAY, JANUARY 24, 1900.

No. 26.

### EMIGRANT DIAMONDS IN AMERICA.\*

**T**HOUGH now found in the greatest abundance in South Africa and in Brazil, diamonds were formerly obtained from India, Borneo and from the Ural Mountains of Russia. Occasionally diamonds have come to light in other regions than those specified. The Pied-

region between southern Virginia and Georgia, some 10 or 12 diamonds, which have varied in weight from those of two or three karats to the "Dewey" diamond, which when found weighed over 23 karats.

It is, however, in the territory about the Great Lakes that the greatest interest now

region, where their distribution was such as to indicate with a degree of approximation the location of their distant ancestral home.

In 1883 the "Eagle Stone" was brought to Milwaukee and sold for the nominal sum of \$1. When it was submitted to



Copyright, 1899, by George F. Kunz.

FIVE VIEWS OF THE EAGLE DIAMOND (sixteen carats); enlarged about three diameters.  
(Owned by Tiffany and Company.)

We are indebted to the courtesy of Mr. G. F. Kunz, of Tiffany and Company, for the illustrations of the Oregon and Eagle diamonds.

mont plateau, at the southeastern base of the Appalachians, has produced, in the

\*This extract is from an important contribution—from a scientific standpoint—to *Appleton's Popular Science Monthly*, by Prof. William Herbert Hobbs, and is taken with the courteous permission of D. Appleton & Co.

centers, for in this region a very interesting problem of origin is being worked out. No less than seven diamonds, ranging in size from less than four to more than 21 karats, not to mention a number of smaller stones, have been recently found in the clays and gravels of this re-

competent examination the public learned that it was a diamond of 16 karats' weight, and that it had been discovered seven years earlier in earth removed from a well opening. Two events which were calculated to arouse local interest followed directly upon the discovery of the real na-



# We Give a Guarantee That Means Something.



THIRTY years of experience in the manufacture of Gold-Plated Jewelry should result in gaining the entire mastery of the art. This is our experience and we shall give you the benefit of it in a line of goods that are guaranteed by a house which has for all these years held to that high standard of quality, which has never failed to give satisfaction, both to the Jeweler who sells them and to the Customer who wears them.

### Chains.

A full line of Vest Chains for Gentlemen, also Dickens, Ponies, Silk Ribbon and Hair Chains, and Lorgnette Chains for Ladies.

### Locketts and Charms.

A choice collection of beautiful patterns in fine Gold front, engraved by hand and some set with stones. By our special process the stock in these goods is left hard and bright, just as it comes from the burnishing rolls.

### Bracelets.

This style of Bracelet was original with us, and about all the patterns now on the market were first put out by us. We make them in Rolled Gold plate and Sterling Silver, both plain and heavily carved.

### Pins and Buckles.

These patterns in Gold-Filled and Silver are entirely new this season. The styles are original and we finish them in all the shades of bright Roman, Rose, Silver and Grey finish.

### Dumbbell Buttons.

These, like our Locketts, are made by a process which leaves the gold on them hard and bright, just as it comes from the rolls. We have a large number of entirely new and unique patterns and we are prepared to fill your orders at once.

All of these goods are included in our broad and liberal guarantee, and should any goods fail to give entire satisfaction we stand ready to replace them at any time.

## THEODORE W. FOSTER & BRO. CO.,

Manufacturing Jewelers and Silversmiths,

Successors to FOSTER & BAILEY.

100 Richmond St., Providence, R. I.

1900. \_\_\_\_\_ Everybody Happy!

**THE RETAIL TRADE**

should hasten to replenish their stock of



than which nothing is more sure of sale.

DON'T WAIT FOR OUR TRAVELERS, BUT SEND AT ONCE TO

**M. B. BRYANT & CO.,**

10 MAIDEN LANE, NEW YORK.

---

**DEITSCH BROS.,**  
14 East 17th St.,  
New York.

LEATHER, SHELL,  
EBONY, IVORY.

---

**FERD. FUCHS & BROS.,**  
**SILVERSMITHS,**  
MAKERS OF STERLING SILVERWARE,  
34 East 20th St., - New York.

---

**SIMONS BROS. & CO.** PHILA.  
NEW YORK  
SILVERSMITHS, JEWELERS. CHICAGO  
MAKERS OF GOLD AND SILVER THIMBLES

**AIKIN, LAMBERT & CO.,**  
MANUFACTURERS OF  
FINE GOLD PENS, HOLDERS, PENCILS,  
TOOTH PICKS and NOVELTIES.

PAUL E. WIRT FOUNTAIN PENS, at new and lower prices . . .  
MERCANTILE FOUNTAIN PENS, guaranteed to give satisfaction.

Catalogues with terms and discounts furnished to the trade.

BRANCH, 103 STATE STREET, - - - CHICAGO.

**AIKIN-LAMBERT JEWELRY CO.,**  
IMPORTERS OF  
**DIAMONDS.**  
JOBBERS IN  
WATCHES, JEWELRY, CHAINS,  
NOVELTIES, ETC.

LATEST DESIGNS. LOWEST PRICES.

**19 MAIDEN LANE, NEW YORK.**

# A Prosperous Holiday Trade,

we hope, was your good fortune to experience.

The time consumed in the salesroom during that interval had a natural tendency to cause an accumulation of work, and possibly you ran short of material beforehand, did not have the time to order and do not now have sufficient supplies for your future requirements. If these were the conditions, we should like and hope that you will not overlook the fact that we are able to help you out.

We increased our stock considerably during December, our dull season, believing that there would be more than a normal demand later on, and we are now fully prepared to cope with all emergencies that may arise and to replenish your stock in all departments.

Our equipment is modern and complete, facilities of the highest order, and our promptness all that could be desired. On these good points we base our past success.

We are grateful for your former favors and shall strive to merit a continuance of your appreciated patronage by rendering the best possible service.

In conclusion, we extend to you our best wishes for a Happy and Prosperous New Year.

## L. C. REISNER & CO.,

Manufacturing Jobbers, Importers and Exporters,  
Watch Materials, Tools and Supplies,

Jewelry Repairers for the Trade.

LANCASTER, PA.

OPEN YOUR CAMPAIGN  
 FOR THE COMING SEASONS WITH  
 A STOCK OF FAHYS RELIABLE  
 GOLD FILLED CASES

THE RALEIGH  
 THE CAMBRIDGE  
 THE OLYMPIA

Contain all the requisite features  
 of perfect gold filled watch cases

*Fahys*

*Trade Mark*

CATALOGUE ON APPLICATION

JOSEPH FAHYS & CO.

ESTABLISHED 1857.

FAHYS BUILDING  
 NEW YORK



F 596

THE CAMBRIDGE



F 525

THE OLYMPIA



THE RALEIGH



# The Last Shall be First. 1900

All conditions indicate that the last year of the century will be the best and most prosperous one. The retail jeweler can assure this beyond peradventure if he will carry in stock a complete line of

## The Standard Simmons Chains.

They are the best chains of the century, the acme of the chain-maker's art, and the 1900 line is better than ever. The same can be said of our

**CYRANO CHAINS, LOCKETS, SEALS AND  
MARLOWE BRACELETS.**

...AT JOBBERS...

# R. F. SIMMONS & CO.

New York Salesroom:  
9-13 MAIDEN LANE.

Factory and Main Office:

ATTLEBORO, MASS.

SALESMEN FOR 1900.

Western Representative, LOUIS E. FAY.

Eastern Representative, GEORGE L. SWEET.

New York Representative, JOHN DRAKE.

# "1835 R. WALLACE"

*"The Stuart"*

WE HERE ILLUSTRATE  
OUR NEW PATTERN IN PLATED  
FLATWARE "THE STUART."

THIS PATTERN WAS ORIGINALLY IN-  
TENDED TO BE MADE ONLY IN A VERY  
FEW PIECES BUT ON ITS INTRODUCTION  
TO THE TRADE THE POPULAR FAVOR  
WITH WHICH IT WAS RECEIVED PROMPT-  
ED US TO MAKE THE PATTERN  
COMPLETE:

WE HAVE NOW READY FOR  
DELIVERY OVER FIFTY (50)  
DIFFERENT ARTICLES WHICH  
INCLUDE NEARLY ALL OF THE  
FANCY PIECES AND HOLLOW  
HANDLED TABLE CUTLERY

SEND FOR PAMPHLET No. 12  
ILLUSTRATING THIS PATTERN

**R. WALLACE & SONS  
MFG. CO.**

FACTORIES,  
WALLINGFORD  
CONN.

BRANCHES

226 FIFTH AVE. NEW YORK  
109 WABASH AVE. CHICAGO  
120 SUTTER ST. SAN FRANCISCO  
63 BASINGHALL ST. LONDON E.C.

SALAD  
SPOON.

SALAD  
FORK.

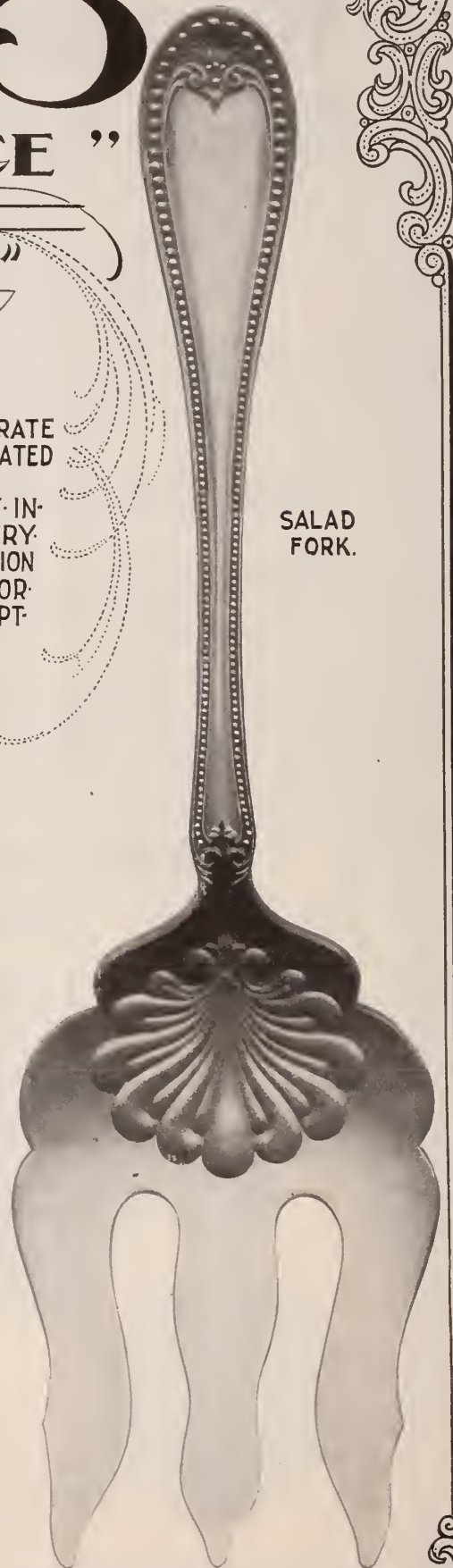
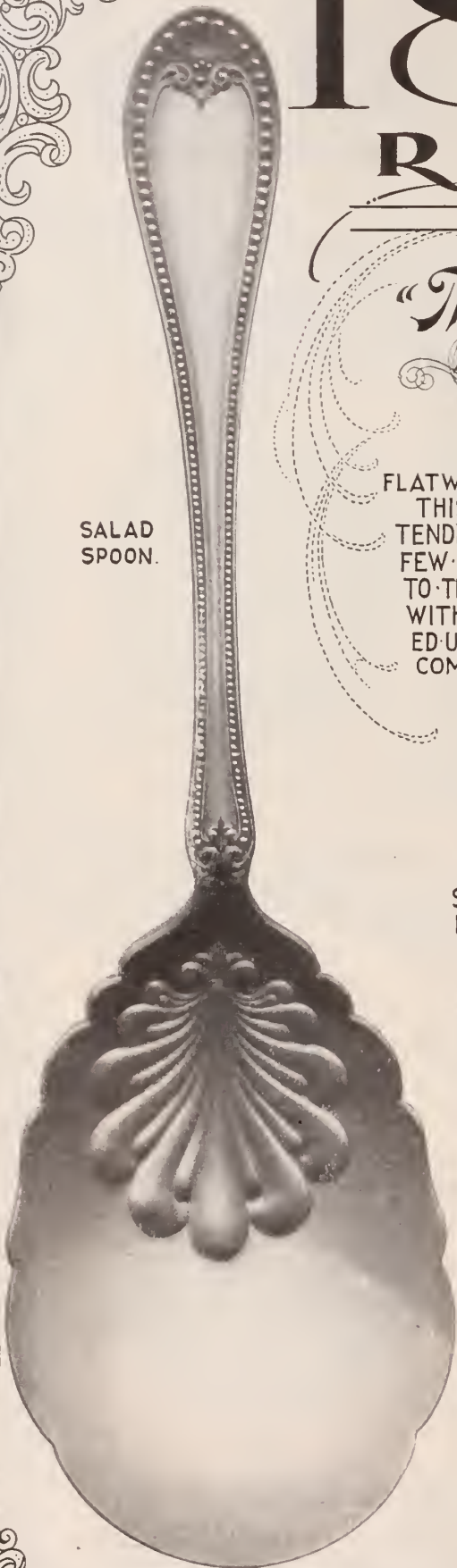

ture of this gem, after which it passed out of the public notice. The woman who had parted with the gem for so inadequate a compensation brought suit against the jeweler to whom she had sold it, in order to recover its value. This curious litigation, which naturally aroused a great deal of interest, was finally carried to the Supreme Court of the State of Wisconsin, from which a decision was handed down in favor of the defendant, on the ground that he, no less than the plaintiff, had been ignorant of the value of the gem at the time of purchasing it. The other event was the "boom" of the town of Eagle as a diamond center, which, after

dumping ground of the ice for its burden of boulders, gravel and clay at the time of its later invasion, and hence indicates the boundaries of the territory over which the ice mass was then extended. In view of the fact that two of the three stones found had remained in the hands of the farming population, without coming to the knowledge of the world, for periods of eleven and seven years respectively, it seems most probable that others have been found, though not identified as diamonds, and for this reason are doubtless still to be found in many cases in association with other local "curios" on the clock shelves of country farmhouses in



Copyright, 1899, by George F. Kunz.

FOUR VIEWS OF THE OREGON DIAMOND; enlarged about three diameters (Owned by Tiffany and Company.)

the finding of two other diamonds with unmistakable marks of African origin upon them, ended as suddenly as it had begun, with the effect of temporarily discrediting, in the minds of geologists, the genuineness of the original "find."

Ten years later a white diamond of a little less than four karats' weight came to light in a collection of pebbles found in Oregon, Wisconsin, and brought to the writer for examination. The stones had been found by a farmer's lad while playing in a clay bank near his home. The investigation of the subject which was thereupon made brought out the fact that a third diamond, and this the largest of all, had been discovered at Kohlsville, in the same State, in 1883, and was still in the possession of the family on whose property it had been found.

As these stones were found in the deposits of "drift" which were left by the ice of the Glacial period, it was clear that they had been brought to their resting places by the ice itself. The map reveals the additional fact, and one of the greatest significance, that all these diamonds were found in the so-called "kettle moraine." This moraine or ridge was the

vicinity of the "kettle moraine." The writer felt warranted in predicting, in 1894, that other diamonds would occasionally be brought to light in the "kettle moraine," though the great extent of this moraine left little room for hope that more than one or two would be found at any one point of it.

In the time that has since elapsed diamonds have been found at the rate of about one a year, though not, so far as I am aware, in any case as the result of search. In Wisconsin have been found the Saukville diamond, a beautiful white stone of six karats' weight, and also the Burlington stone, having a weight of a little over two karats. The former had been for more than 16 years in the possession of the finder before he learned of its value. In Michigan has been found the Dowagiac stone, of about 11 karats' weight, and only very recently a diamond weighing six karats and of exceptionally fine "water" has come to light at Milford, near Cincinnati. This augmentation of the number of localities, and the nearness of all to the "kettle moraines," leaves little room for doubt that the diamonds were conveyed by the ice at the time of its later invasion of the country.

**Imports of Jewelry and Kindred Lines into the Hawaiian Islands.**

WASHINGTON, D. C., Jan. 18.—The Secretary of State has sent a report to Congress covering the imports and other statistical and commercial data of the commerce of the Hawaiian Islands for the year of 1898, in which appear the following from the United States:

Seven thousand eight hundred and nine clocks and six cases of clocks, at a total value of \$6,372.03; clock material, \$35.30; plated ware, \$4,476.86; silver ware, \$6,193; spectacles and eyeglasses, 443 dozen, \$1,070.89; watches, 431 silver, 1,562 nickel, 1,766 of various other kinds, at a combined value of \$9,304.82; watch movements and cases, including 70 cases and 72 movements, at a combined value of \$318.80; watch material, \$76.75; sundry cheap jewelry, \$2,572.14; sundry jewelry, \$1,117.46.

The importations by parcels post from the United States also included jewelry to the value of \$10,634.37; watches and cases, \$6,392.64.

The imports from Great Britain during the same year included clock material, \$9.70; spectacles and eyeglasses, four gross and 19 dozen, \$34.11; various cheap jewelry, \$573.39; 78 watches of various kinds, \$212.80; also by parcels post, watches and cases, \$1,101.82, and jewelry, \$5.

Importations from Germany during the year include 200 clocks, \$103.15; clock material, \$4.30; silver ware, \$719.93; plated ware, \$54.41; 15 dozen spectacles and eyeglasses, \$17.25; 21 watches of various kinds, \$105.75; cheap jewelry of various kinds, \$570.96; sundry other items of jewelry, \$36.80.

Six hundred and ninety-two clocks were imported from China during the year at a total value of \$813.70; five packages of plated ware, \$7.50; silver ware to the value of \$336.89; sundry items of cheap jewelry, \$1,004.31; five watches of various kinds and one silver watch, at a total value of \$44, and sundry items of jewelry, \$11.20.

Japan contributed 381 clocks at \$475.41; 50 dozen spectacles and eyeglasses at \$7.09; 55 watches of various kinds at \$168.37; various cheap jewelry, \$349.44, and one package of watch material at \$12.39.

From Canada by parcels post they re-

SCIENTIFIC RUBIES	OPALS	OLIVINES	CATSEYES	SAPPHIRES	DIAMONDS	RUBIES	EMERALDS	PEARLS	PEARL NECKS	PEARL ROPES	Pearl Collarettes, mounted with Diamond Bars.	
			<p><b>PEARLS, DRILLED AND UNDRILLED.</b></p> <p><b>PEARL ROPES, NECKS and COLLARETTES.</b></p> <p><b>We are buyers of American Pearls.</b></p>									
			<p>LONDON: 19-20 Holborn Viaduct. <b>JOSEPH FRANKEL'S SONS,</b> 68 Nassau Street, NEW YORK.</p> <p>TELEPHONE, 2733 JOHN.</p>									
			<p>FANCY COLORED DIAMONDS and GEMS in PEARLS and PRECIOUS STONES.</p>									

**DIAMONDS.**  
**Wm. S. Hedges & Co.,**  
 IMPORTERS OF  
**Diamonds and Precious Stones.**  
**DIAMOND JEWELRY.**  
**170 Broadway, New York.**  
 26 Holborn Viaduct, London.

*Oppenheimer Bros. & Veith,*

*Importers and Cutters of*

*Diamonds*

*Dealers in*

*Watches,*

*Cor. Nassau and John Streets,*  
 (PRESCOTT BUILDING.)

*....New York....*

*Amsterdam,*  
*2 Tulp Straat.*

*London,*  
*45 Holborn Viaduct.*

**MOUNT & WOODHULL,** FORMERLY WITH LATE FIRM OF  
 RANDEL, BAREMORE & BILLINGS,  
 . . . IMPORTERS OF . . .

**Diamonds, Other Precious Stones, Pearls, Etc.,**  
**Makers of fine DIAMOND JEWELRY,**

26 MAIDEN LANE (SOUTHWEST CORNER,  
 NASSAU STREET), NEW YORK.

JOHN C. MOUNT.

ADDISON W. WOODHULL.

RUBIES.

SAPPHIRES.

**C. G. MALLIET & CO.,**

EMERALDS.

14 MAIDEN LANE, N. Y.

DIAMONDS.

**The Bowden Rings**

ARE COMPLETE IN VARIETY, CORRECT  
 IN QUALITY AND PERFECT IN FINISH.  
 WE MAKE EVERY VARIETY OF FINGER  
 RINGS

**J. B. BOWDEN & Co.,**

1 MAIDEN LANE,

NEW YORK.

ceived watches and cases to a total value of \$589.48, and jewelry to the amount of \$313.74. From Australia and New Zealand one package of jewelry, valued at \$9.50.

The importations from France along these lines were not what might have been expected, only amounting to \$98.66 for cheap jewelry and \$270.90 for 57 pairs of opera glasses.

In smaller amounts from other countries the contributions included plated ware to the value of \$24 and cheap jewelry, \$213.41.

Among the items imported free of duty are included jewelry, \$1,052.50, and silver ware, \$300.

#### Civil Engineers Discuss the French 24-Hour Clock System.

At the fourth annual session of the American Society of Civil Engineers, held Wednesday, at 220 W. 57th St., New York, an animated discussion took place over the 24-hour clock system. It began with the reading of a report from an old Standard Time Committee, of which Sanford Flemming, of Toronto, was chairman. This committee have been making reports for 25 years, and it was as a result of their labors that the system of standard time was adopted officially in the United States. The report favored the French system of counting hours from 1 to 24.

Several speeches were made in favor of the system. Charles H. Mixer, of Rumford Falls, Me., said that he used the system altogether, that his workmen understood it and that fewer mistakes were made than under the A. M. and P. M. system in vogue. Others argued that people generally cling to the old system because the new one sounded strange.

#### Henry Silverthorn Celebrates His 90th Birthday.

LYNCHBURG, Va., Jan. 18.—Probably the oldest citizen of Lynchburg at this time is Henry Silverthorn, who on Jan. 10 celebrated in a quiet manner the 90th anniversary of his birthday. He is in good health and spirits, and almost daily walks from his home on Floyd St. to his son's store on Main St. Mr. Silverthorn was born in Accomac county and learned the silversmith's business in Baltimore. He came to Lynchburg in 1832 and found employment in the store of Williams & Victor, for whom he made by hand spoons, forks, ladles, tea sets and many other pieces of silver ware which to-day are bought in the north, where they are made by machinery. In 1837 Mr. Silverthorn started himself in business, which he conducted successfully through the perilous years of the war. In 1876 his store was burned out, and he then moved to the store now occupied by H. T. Silverthorn.

Mr. Silverthorn retired from business about two years ago. He is the father of 12 children, only two of whom are now alive. Mr. Silverthorn attends the Methodist Protestant church, of which he was one of the original members.

**Precious Stones: London Market.**

HATTON GARDEN, London, Eng.,  
Jan. 12, 1900.

If all the gloomy anticipations of business are realized, it will be necessary to print future reports in black borders! People seem to think trade is going to what Mr. Mantalini politely designated "the demnition bow-wows." A few odd orders are reported on American account, but they are of no bulk, nor do dealers expect much yet awhile in that quarter. Reports from Paris are somewhat comforting in the sense that they appear to be very little better off there. Undoubtedly the war and its attendant evils will affect the Exhibition returns to a serious extent.

Supplies of fine stuff in first rank gems are more plentiful than they have been for months. No relaxation in values is, however, so far reportable. It is probable that pearls and emeralds would be the first to suffer if the diminished demand causes prices to go down. The supplies from Ceylon of pearls continue to come over as usual, and a certain accumulation of stock appears inevitable. The Ceylon houses practically form a ring, controlling the output from the fisheries, and they ship the goods to two London firms, by whom they are sold on the market. The two firms referred to are practically intermediaries only, and it will rest with the Ceylon merchants to decide to hold or to sell at best obtainable prices. The position differs essentially from that of diamonds, because there is no suggestion of an unlimited supply of pearls, and given normal trade conditions, the market could profitably absorb more than usually comes forward.

No change is noticeable in the condition of the diamond market. Stock Exchange opinion is still depressed, DeBeers shares keeping very little over 22. R. F.

**Notes from London.**

*English Lever Watch Case.*—The important case in the courts relating to so-called English lever watches is still *sub-judice*, and is attracting considerable interest in trade circles. The case for the prosecution (which has not yet been closed) occupies over 15 pages in a trade journal of the size of THE CIRCULAR. The drift of the cross-examination appears to be (1) that the prosecution also uses foreign material in English Hall-marked watches, and (2) that the bulk of the parts alleged to be of foreign make are actually made in Coventry, the suggestion being that Swiss machinery being used accounts for the un-English appearances. Both of counsel and magistrate show a grasp of technicalities in watchmaking which would do many watch jobbers credit. Mr. Hewitt, the managing director of the Lancashire Watch Co., stated that they used machinery whenever they could, some of which they made themselves and some they obtained from America. R. F.

The Trenton Watch Co., Trenton, N. J., are advertising for boys to learn the watchmakers' trade at their factory.

# Pearls ————— Opals

Importers and Cutters **GOODFRIEND BROS.,** Precious and Imitation Stones  
9-13 Maiden Lane, N. Y. 174 Weybosset St., Providence, R. I. 10 Rue Cadet, Paris.  
TELEPHONE, 662 CORTLANDT.

## SCHULZ & RUDOLPH,

...Importers and Cutters of...

**..DIAMONDS..** .....AND OTHER....  
**PRECIOUS STONES.**

SOLE AGENTS FOR THE CELEBRATED

**JULES JÜRGENSEN WATCHES AND CHRONOMETERS.**  
COPENHAGEN,

28 John and 65 Nassau St., New York.

**John F. Saunders,** Cutter and Importer of

**DIAMONDS** AND OTHER  
PRECIOUS STONES.

FINE PEARLS A SPECIALTY.

68 Nassau St., cor. John St., Sheldon Building, Room 16, NEW YORK.

**Stern Bros. & Co.,**

Cutters of ...

MANUFACTURERS OF

**DIAMONDS,** Gold Rings and Thimbles,

68 NASSAU STREET, NEW YORK.

RING FACTORY, 33-43 GOLD STREET, NEW YORK. LONDON OFFICE, 29 ELY PLACE.  
DIAMOND-CUTTING WORKS, 142-146 W. 14TH ST., NEW YORK. CHICAGO OFFICE, 149 STATE ST



**Eliassof Bros. & Co.,**

IMPORTERS AND JOBBERS OF

**DIAMONDS, WATCHES, JEWELRY,**

9-11-13 Maiden Lane,

Materials, Tools and Optical Goods.

NEW YORK.

ALBANY OFFICE: 62 & 64 STATE STREET.

## PEARLS.

**"On the Spot."**

We are thoroughly in touch with the principal pearl and precious stone markets of the world. The markets' every change and fluctuation, no matter how slight, is known to us, and in consequence we are ever in a position to avail ourselves of opportunities opened up by a change in market conditions. The gain is our customers' gain.

**Alfred H. Smith & Co.,**

182 Broadway, N. Y.

CHICAGO,  
103 State Street.LONDON,  
21 Holborn Viaduct.

## DIAMONDS

And Other Precious Stones.



**"The  
Pearl  
House."**

We have no salesmen;  
call or write.

**EISENMANN BROS.,**

PARIS, 3 Rue St. Georges.

21 &amp; 23 MAIDEN LANE, NEW YORK.

**MATHEWS & PRIOR,**

DESIGNERS AND MAKERS OF

**Sterling Silverware**

TO THE LEGITIMATE

**JEWELRY TRADE ONLY,**245-247 West 28th Street,  
New York City.**Meeting of the Creditors of the J. B. Gotthelf Jewelry Co.**

A meeting of the creditors of the J. B. Gotthelf Jewelry Co., Memphis, Tenn., was held Wednesday afternoon at the office of Leo N. Levi, 27 Pine St., New York. The debtor firm were represented by Eugene Freedman, who had come to New York to present a statement to the creditors. According to this statement the Gotthelf Jewelry Co. owe \$33,130.81, and the assets at their book value equal \$21,695. In detail, the assets consist of, at book value, merchandise, \$8,505; accounts, \$9,000; fixtures, \$2,075, and equity in diamonds pledged as collateral, \$1,215.

No offer of settlement was made, but Mr. Freedman offered on his own behalf to buy the assets of the concern for enough to pay the creditors 25 per cent in cash on their claims. The proposition to permit him to do so was declined by those present, and it was verbally agreed to put the claims into the hands of the Jewelers' Association and Board of Trade, and have that body take action to preserve the interest of all creditors. It was contended on the part of Gotthelf that he was in business alone, though many of the creditors believed that Mr. Freedman was interested. He, however, denied this.

## RECEIVER PETITIONED FOR.

MEMPHIS, Tenn., Jan. 20.—Application for the appointment of a receiver for the property of J. B. Gotthelf Jewelry Co. has been made to the State court of this city. By an agreement between the attorneys for the Jewelers' Association and Board of Trade and the attorneys for the debtor, the name of R. G. Brown will be offered to the court as a nominee for receiver, who will be satisfactory to both sides. It is probable that Mr. Brown will be appointed.

**The Wholesale Jewelry Stock of H. Koester & Co. Sold to Mortgagees.**

DETROIT, Mich., Jan. 19.—The wholesale jewelry stock of H. Koester & Co. was sold on Wednesday to the Home Savings bank for \$5,000. There were no other bidders. The bank held a mortgage aggregating \$10,500. The stock inventoried far beyond the price at which the stock was bid in. The place at 106 Woodward Ave. is still closed up, and the bank officials have not yet decided what will be done with the stock, although an auction sale will probably take place. Mr. Koester will probably devote himself to a new can top fastener, an invention that promises well.

**Death of Benjamin J. Franklin.**

POTTSVILLE, Pa., Jan. 18.—Benjamin J. Franklin, a respected resident of Mahanoy City, died at his home, 115 W. Mahanoy Ave., Tuesday morning, after a lingering illness of one year, death being due to consumption. Deceased was born in Columbus, O., 33 years ago. He had been a resident of Mahanoy City for the past 12 years, where he had conducted a jewelry business. He is survived by a wife and four children.



### STAPLE SILVERWARE.

Do not experiment with new or untried values in Silver-Plate. Wares bearing the trade-marks here shown have been sold for half a century, and can safely be looked upon as staple. Past reputation has made them a reliable and salable quality, and will continue to make them brands sought after by the consumer.

To stimulate the sale they have been largely advertised, and in the future will be kept before the public by attractive announcements in all leading periodicals, ensuring an ever-increasing demand. The dealer will be materially benefited by having a good assortment of these goods to show possible customers.

TRADE-MARK  
ON  
TEA SETS.  
ETC.  
MADE AND  
GUARANTEED BY



International Silver Co., Successor to  
**MERIDEN BRITANNIA CO., = MERIDEN, CONN.**  
 New York. Chicago. San Francisco.

TRADE-MARK  
ON  
SPOONS,  
ETC.

**"1847  
 Rogers  
 Bros."**

**Important Decision Regarding Operation of National Bankruptcy Law.**

ALBANY, N. Y., Jan. 20.—In a decision handed down in the United States Circuit Court here to-day Judge Coxe holds that all judgments and levies of the State Courts are null and void so far as they relate to the property of a bankrupt if recovered within four months prior to the filing of a petition in bankruptcy, either voluntary or involuntary. Judge Coxe also holds that all creditors of a bankrupt are to be considered equal.

This is the first time the question at issue has been decided in this district, although there have been decisions in other districts, some holding one way, some another. Judge Thomas, of Brooklyn, has

held that only when a petition is filed against a bankrupt do the judgments fall.

**Annual Meeting of the Jewelers' & Tradesmen's Co.**

The annual meeting of the Jewelers' & Tradesmen's Co. was held Jan. 15. The officers of the company were all re-elected with the exception of the president, which office has been vacant since the death of the late Samuel W. Saxton. George Merrill was elected as Mr. Saxton's successor.

The reports of the officers show the business of the company to be larger and better than for some time past, and also show the institution to be in a healthy financial condition.

**Importations at the Port of New York.**

*Weeks Ended Jan. 20, 1899, and Jan. 19, 1900.*

China, Glass and Earthen Ware:	1899.	1900.
China .....	\$43,304	\$26,866
Earthen ware .....	9,864	16,444
Glass ware .....	9,853	10,673
Optical glass .....	.....	1,404
Instruments:		
Musical .....	10,047	10,161
Optical .....	3,980	3,903
Philosophical .....	35	4,562
Jewelry, etc.:		
Jewelry .....	12,092	17,282
Precious stones .....	155,977	58,671
Watches .....	10,215	8,487
Metals, etc.:		
Bronzes .....	1,533	1,210
Cutlery .....	29,540	24,880
Dutch metal .....	.....	2,266
Platina .....	31,057	13,706
Plated ware .....	131	.....
Silver ware .....	32	228
Miscellaneous:		
Alabaster ornaments .....	595	13
Amber .....	6,188	.....
Beads .....	1,936	636
Clocks .....	2,105	2,273
Fans .....	14,966	4,767
Fancy goods .....	4,547	6,750
Ivory .....	.....	484
Ivory, manufactures of.....	27	1,060
Marble, manufactures of.....	12,265	3,491
Statuary .....	868	66

**Aaron Carter's Partners Gracefully Remember Him on His Birthday.**

Aaron Carter, who may be justly termed the dean of American manufacturing jewelers, celebrated his 83d birthday on Jan. 17. The partners of the firm, Carter, Hastings & Howe, of which he has been so many years the head, took this occasion to present to Mr. Carter a handsome silver loving cup as a memento of their esteem and affection. The loving cup is four-quart size and bears the following inscription:

AARON CARTER,  
FROM HIS  
PARTNERS  
ON HIS  
83D BIRTHDAY,  
JANUARY SEVENTEENTH,  
1900.  
C. E. HASTINGS and W. T. CARTER  
G. R. HOWE and W. T. GOUGH.

Mr. Carter is probably the oldest living manufacturing jeweler, he having founded his present business in 1841, the style then being Pennington, Carter & Doremus. The business has continued from that time under various titles with Mr. Carter's name always at the head. His long and honorable career in the jewelry business is a subject for more than ordinary congratulation, and Mr. Carter has the well wishes of the entire trade, who hope that he may long continue head of the house he has so ably managed these many years.

About 1.30 o'clock Jan. 16, Herman J. Whiting, Clyde, N. Y., was stricken with paralysis, depriving him of the use of his right leg.

In a fire in Murfreesboro, Tenn., a few days ago, the skylight of W. R. Bell's jewelry store was demolished, causing a slight damage to the stock.

**PEARLS.**

While Diamonds remain pre-eminently the most popular of all the precious stones, Pearls are growing in favor constantly with people of quiet and refined tastes.

We have them unmounted in all sizes and a very complete and attractive stock of mounted goods, either alone or in combination with diamonds.

**HAYDEN W. WHEELER & Co.,**

**TWO MAIDEN LANE, N. Y.**

**50 HOLBORN VIADUCT, LONDON, ENGLAND.**



**Interesting Convention of New York State Opticians.**

SYRACUSE, N. Y., Jan. 20.—The January meeting of the New York State Association of Opticians, which was held at the Nester, in Geneva, Wednesday, was a well attended and highly successful affair. Much credit is due the committee on arrangements.

The morning business session opened at 10 o'clock with president Fred. Hamilton in the chair. The usual routine business was disposed of and applications for membership were received from J. Dillaye Wiggins, Trumansburg; A. A. Shaw, of Alfred; George E. Holmes, of Clifton Springs; A. E. Tree, of Groton; Elon F. Smith, of Lockport; D. E. Wilcox, of Albion; Irving E. Richmond, of Newark; Adelbert Groat, of Phelps, and H. E. Rice, of Shortsville; all of which were passed upon favorably.

President Hamilton introduced a proposition for the fusion of the Rochester Optical Club and the New York State Association of Opticians, and a committee composed of B. S. Hopkins, F. L. Swart and W. J. Morse were appointed to promote the consolidation. A change in the number of meetings to be held each year was discussed informally.

A very interesting paper on "The History and Treatment of a Number of Extraordinary Cases of Refraction" was then given by F. E. Robbins, of Elmira, who treated his subject from the standpoint of a physician, as well as that of an optician. The meeting then adjourned to meet at 1.30 o'clock at the office of the Geneva Optical Co., where carriages were in waiting, and a drive about town with visits of inspection to the Geneva and Standard Optical companies' works occupied the time until the evening session. Each visitor was presented by the Geneva Optical Co. with a set of four lens sizers in a morocco case as a souvenir.

At 5 o'clock the members reassembled at the Nester and a hearty vote of thanks was extended to the Geneva and Standard Optical companies for their hospitality and kindly attentions. A resolution of sympathy for G. N. Luckey, of Baldwinsville, on account of the serious illness of his wife, was passed. A press committee, composed of F. E. Robbins, F. L. Swart and G. H. P. Stone, were appointed. An interesting and practical address on "How I Fit Frames," by W. J. Morse, of Rochester, was next given. A most instructive lecture on "Toric Lenses," by Wm. Weidmann, of Rochester, followed, which was read by Frank Walker, of Rochester, Mr. Weidmann being unable to be present. "A Code of Ethics for Opticians" was the title of a very sensible paper by F. L. Swart, of Auburn. Mr. Swart is of the opinion that opticians should be thoroughly organized in order to have a code of ethics effectual. That there should be one national or supreme body with local societies throughout the State or nation, the supreme society to adopt a general code of ethics to govern the local societies, and the local societies to be allowed to make such minor rules as would best suit their immediate circumstances.

A committee of Fred Hamilton, chairman ex-officio, W. J. Morse, F. E. Rob-

bins and George E. Holmes, were appointed to formulate a uniform set of prices for optical work. The meeting adjourned at 7 o'clock for the banquet, which was given to the Association at the Nester by the Geneva and Standard Optical companies. Those in attendance were:

Fred Hamilton, Syracuse; B. S. Hopkins, Penn Yan; F. E. Robbins, Elmira; M. L. Comfort, Owego; F. L. Swart, Auburn; M. J. O'Hara, Camillus; C. B. Hibbard, Pulaski; W. P. Hillick, Fulton; G. S. Benedict, Olean; O. H. Wright, Batavia; G. H. P. Stone, Iion; A. W. Golder, Seneca Falls; A. D. Groat, Phelps; George P. Bausch, W. J. Morse and Frank Walker, Rochester; A. A. Shaw, Alfred; George E. Holmes, Clifton Springs; Dr. E. E. Smith, Lockport; J. D. Wiggins, Trumansburg; C. Mason, Dryden; D. E. Wilcox, Albion; C. J. Fuller, Phoenix; Irving E. Richmond, Newark; H. Rice, Shortsville; E. Tree, Groton; J. E. Brown, H. B. Graves, George R. Travis, Fred L. Spangler, Frank Pearce, S. F. Dey, Marvin R. Rogers, F. G. Jaynes, F. S. Ellsworth, of Geneva.

**Annual Meeting of the Jewelers' Safety Fund Society.**

The annual meeting of the Jewelers' Safety Fund Society was held recently at 32 Liberty St., New York. The following board of directors were unanimously re-elected: Henry Randel; Henry Hayes, of the Brooklyn Watch Case Co.; Wm. R. Alling, of Alling & Co.; Ira Goddard; Jas. C. Aikin, of Aikin, Lambert & Co.; Chas. G. Alford, of C. G. Alford & Co.; James P. Snow, of Snow & Westcott; Louis Kahn, of L. & M. Kahn & Co.; C. E. Hastings, of Carter, Hastings & Howe; Frederick H. Larter, of Larter, Elcox & Co., and Henry E. Ide, of H. C. Hardy & Co.

The board met on the following day

**1852-1900.**

**Forty-eight years** of business life,

**An unblemished reputation**

for products equal to the best,

**One standard—**

Sterling, 925-1000 fine;

**Experienced representatives,**

**A specialty of Tableware,**

salable the whole year through, are facts worthy your consideration in placing your orders for 1900.

**J. B. & S. M. Knowles Co.**



TRADE-MARK.  
Established 1852,  
Incorporated 1891.

**Silversmiths,**

**91 Sabin St., Providence, R.I.**

and elected the following officers for the ensuing year: President, Henry Hayes; vice-president, Jas. C. Aikin; secretary and treasurer, Ira Goddard. The executive committee elected are: Henry Randel, Wm. R. Alling, Louis Kahn, C. E. Hastings and Frederick H. Larter.

**Mrs. Mira J. Smith's Suit Against W. A. Sturgeon et al. Dismissed.**

DETROIT, Mich., Jan. 19.—Judge Waite, on Thursday, handed down a decision dismissing the bill of complaint in the case brought by Mrs. Mira J. Smith against W. A. Sturgeon and others in the old concern of Smith, Sturgeon & Co. She claimed to hold stock in the old concern as collateral security and contended that the recent sale of the assets of Smith, Sturgeon & Co. to Edward Holbrook, who subsequently organized the firm of W. A. Sturgeon & Co., impaired her security. She alleged that the transfer was fraudulent. The defendants claimed the transfer was necessary on account of the insolvent condition of the firm.

Judge Waite in disposing of the case said:

"I find, from the evidence in the case, that at the time of the transfer, on or about July 18, 1899, the company was insolvent, that is, it was unable to meet the debts then due, and was in such a financial condition that it might have been thrown into the hands of a receiver. The testimony shows that the concern was in a failing condition. It had been losing money in the business until at this time it had lost some \$18,000 or \$19,000, and there was at that time nearly \$50,000 due, some of which was being pressed, and suits threatened. The board of directors sold the entire stock in

trade, the same being sanctioned by two-thirds of the capital stock, at a meeting which I hold to have been legally held for that purpose, to Mr. Holbrook, in consideration of his paying the entire debts of the company, which amounted to about \$90,000. The company being insolvent, the stock was worthless, and being worthless, our inquiry need go no farther, if complainant was the only one interested.

"But it is contended that the directors, Dorr and Sturgeon, acted fraudulently in transferring the property of the company to Holbrook, and that therefore the transfer should be set aside, they occupying a fiduciary relation to the concern and the stockholders. I cannot take this view of the matter, as I do not think, according to the facts in the case, that it is a transaction which should be held void because it is against public policy. I cannot hold that the action of Dorr, Sturgeon and Hammond is inconsistent with honesty and good faith, in the face of the testimony."

**Death of an Old Silversmith.**

MERIDEN, Conn., Jan. 20.—Louis Massicotte, aged 57 years, died this morning. Mr. Massicotte was an employe of the Meriden Britannia Co. for 37 years, and had the confidence and esteem of all who knew him.

The man arrested some days ago under the name of George Muller, charged with stealing a loose diamond from a tray at the jewelry house of T. Hauseman & Sons, New Orleans, La., it now transpires is known in Chicago. A letter was received last week by Chief Gaston from the Bertillon bureau of identification, of that city, stating that Muller had been arrested in that city under the name of George Miller, on June 20, 1899, on a charge of larceny and shoplifting.

**Activity of the Optical Society of the State of Pennsylvania.**

PHILADELPHIA, Pa., Jan. 19.—The following notice has been sent to all the opticians in the State of Pennsylvania by the Optical Society of the State of Pennsylvania:

DEAR SIR:—Allow me to call your attention to the importance of all opticians becoming members of the Optical Society of the State of Pennsylvania. A careful perusal of the correspondence given below will, I hope, convince you of the wisdom of such a step.

Again and again members of our profession have been subjected to such threats and intimidations, while the public press has been used on more than one occasion to prejudice the mind of the public against all engaged in this profession who are not physicians, and to prevent, if possible, them from prescribing glasses to correct refractive errors.

You are perfectly well aware that the prescribing and fitting of glasses belong primarily to the optician, just as much as the measuring of a foot for a shoe belongs to the shoemaker, and that where disease does not exist neither the eye nor the foot requires medical treatment.

Our chief object and aim as a society is to elevate the members of our profession, to protect them against just such prosecutions as our members have been subjected to.

Hoping you will decide to join our ranks and stand shoulder to shoulder with us against the common enemy of our profession, I am yours respectfully,

A. MARTIN,  
President Penna. Optical Society.

The correspondence referred to by Mr. Martin is as follows:

MR. A. MARTIN,

DEAR SIR:—We have opened a jewelry and optical store here, and we think it would be a good thing for us and also the profession at large if we became members of the Pennsylvania State Optical Society. If you will kindly send us application blanks we will be pleased to apply for membership.

We recently had an ad. in one of our daily papers which read thus: "If you are troubled with headache caused from poor eyesight call on Magee & Eichenberg and have your eyes examined free of charge." The next day we received a letter from a young doctor here who claims to be an oculist. What experience he has had in treating eye disease or where he studied to be an oculist we do not know. He has always been known as an ordinary physician until about two years ago, when he started in as an eye, ear and throat specialist. The following is an exact copy of his letter to us:

MESSRS. MAGEE & EICHENBERG,

GENTLEMEN:—I noticed an advertisement in one of the papers in which you speak of curing headache. Now, under the laws of this State any attempt to cure bodily infirmities without being licensed to do so subjects the offender to fine and imprisonment. As opticians you are privileged to fit lenses to the eyes, but any attempt on your part to set yourselves up as eye specialists or offering to treat eye diseases or infirmities will be considered sufficient warrant for legal prosecution. If you are a capable optician I personally will not hesitate to send you prescriptions, but only as you stick strictly to the optical part of it, otherwise, as I said before, the Medical Society and I personally shall bring your case before the proper authorities. Trusting that we shall not be obliged to resort to anything of that sort, I remain very respectfully,

M. V. BALL.

The next examination for the dioptrician grade, of the Optical Society of the State of Pennsylvania will be held at Philadelphia, Tuesday, March 13, 1900, at 10 o'clock A. M. There will also be a meeting of the society the same evening, at which papers pertaining to the profession will be read. Only members of the association can take this examination and obtain the certificate, but any optician who applies for membership in the association at the next meeting of the executive committee, Feb. 13, can be admitted in time to join the examination. Application should be made at once to H. F. Freeman, West Chester, Pa.

Applicants are examined in the theory of optics, refraction, the use of the trial case and frame fitting, the examination being both written and oral. There is no charge for taking this examination, but those who pass pay \$5 for their certificate, which is handsomely engraved.

**PRICES ARE STIFFENING UP ALL AROUND**

Quotations on Watches should be endorsed:  
Prices or discounts subject to change without notice.

**TO ORDER ADVANTAGEOUSLY, 'TWERE WELL TO ORDER QUICKLY.**

"A WORD TO THE WISE IS SUFFICIENT."

WE ARE THE LARGEST DISTRIBUTORS OF

**Dueber-Hampden Watches**

IN AMERICA.

RAILROAD WATCHES A SPECIALTY.



*John N. Ferwood & Co.*  
Watches. Chains. Diamonds. Jewelry.

No. 3 MAIDEN LANE, NEW YORK.

# THE DUEBER HERALD

THE ADVOCATE OF HONEST BUSINESS METHODS.  
DEVOTED TO THE RETAIL JEWELRY TRADE.

Vol. I

CANTON, OHIO, JANUARY, 1900.

No. 13

## TWO QUESTIONS AND A THOUGHT.

Put on your Thinking Cap.

\* \* \*

Why do the management of the Dueber-Hampden Works so persistently and so doggedly urge investigation of all their claims?

\* \* \*

And why is it that they break the general rule and persistently and doggedly urge a study of the watch situation, instead of scattering broadcast a few high-flown sentences and letting it go at that?

\* \* \*

Can you answer the questions?

1

The Dueber-Hampden Works are the largest, best-appointed watch manufacturing plant in the world.

2

The Dueber-Hampden Works have exposed and defeated practically every abuse in the watch industry, and are the successful champions of Honesty in watchmaking.

3

The Dueber-Hampden Works are the only watch manufacturing plant in America producing a complete watch (movement and case).

4

The product of the Dueber-Hampden Works is absolutely peerless.

## NEW LIGHT ON AN OLD MAXIM.

"Give the people what they ask for" is, if judiciously applied, an excellent business maxim; but it is bad and unsound business policy if obeyed implicitly and carried to extremes.

The man who asks for cheese, does not want to be sold butter. But there may be two kinds of cheese; and if the customer asks for the inferior brand, it is the dealer's business to suggest that there is a better one, on the chance that the customer may not be aware of it.

The man who walks into your store and asks for a certain article, calling it by name, does so because, in all likelihood, he has somehow become impressed with what he believes to be that particular article's merit. He believes it to be a good article. He buys it on faith.

Then is your time to talk.

If you have reason to think that your customer requests that particular article because he is ignorant of the existence of a better one, inform him. If there is none better, close the sale at once and tell him he's buying the best.

To sell an inferior article, simply because it is called for, without attempting to enlighten your customer, means, that if the purchase proves unsatisfactory, you get all the blame; on the other hand, to sell on the strength of urgent recommendation, what you know to be a superior brand, though an inferior brand was requested, will invariably result in a satisfied customer and win for you the customer's complete faith and confidence.

The dealer's duty to himself and to his customers does not begin and end with the operation of making a sale. He must make it a profitable sale for himself and a profitable purchase for his customer.

Therefore, let the dealer be posted on the goods he sells.

## "PRETTY GOOD, IS IT NOT?"

Cazenovia, N. Y.

Dueber-Hampden Watch Co., Canton, O.

Gentlemen:—Some time ago I wrote you of the good performance of one of your watches. I send you the rate for a week as kept by the owner, who is depot agent of the E. C. & M. R. R. at this place. I asked him to compare it with the telegraphed time each day and note the rate. The variation is scarcely perceptible.

Pretty good, is it not?

Yours,  
J. W. HULL,  
Horologist and Optician.

## "CANNOT BE BEATEN."

Cumberland Valley R. R.

I am engine house foreman at White Hall Station. Have been carrying one of your railway movements in one of your fine gold-filled cases. It has not been further than eight seconds away from the correct time and cannot be beaten by any watch made.

W. H. WISE.

## "WOULD NOT BE WITHOUT THEM."

Chicago, Ill.

My 'pard' and I carry on our engine, Dueber-Hampden 17-jewel watches, Nos. 709,346 and 857,004. We are very much pleased with them, and can safely say we are always on the dot. They give the best of satisfaction and we would not be without them.

J. F. JORDAN,  
W. H. CRAWFORD.

## ANOTHER RECOMMENDATION.

Dayton, O.

I am an engineer on the C., H. & D. R. R. I have used one of your best Hampden watches for the last ten years, and it has given me the best of satisfaction. I would recommend it to any railroad man for keeping good time.

CHRIS. L. SWEETMAN.

## "THE FINEST IN THE WORLD."

Cumberland, Md.

I am conductor on the B. & O. R. R. It is a question of seconds with the Dueber-Hampden watches, for the one I have got is one of the finest in the world.

J. R. FISHER.

# **Busiest House in America.**

---

We are dealers in everything the Retail Jeweler wants.

Our Spring lines of standard goods and novelties are complete, and new goods are arriving daily, embracing the latest productions of eastern factories.

An order sent to us will be filled immediately.

**Send for our 1900 catalogue if you haven't received one.**

**LAPP & FLERSHEM,**

191, 193, 195 State Street, = = Chicago.

---

# **Busiest House in America.**

*THE Chicago Jewelers Association  
cordially invite you to attend their  
Twenty-third Annual Banquet  
on Friday evening, January the nineteenth  
nineteen hundred, at seven o'clock.  
Kinsleys.*

*Banquet Committee:*

*Lem W. Flershem, Chairman,  
Albert L. Sercomb,  
M. A. Mead.*

*W. H. Vogell,  
James A. Todd,  
C. J. Dodgshun, Ex Officio.*

C. D. PEACOCK

CHICAGO, Ill., Jan. 19.—There have been jewelers' banquets in the past and jewelers' banquets are to be expected in the future, but the rate of progress evidenced by the Chicago Jewelers' Association at Kinsley's to-night, will be impossible to maintain at future occasions of the kind. It was the 23d annual banquet of the association and was remarkable in many ways. In the selection of speakers, the choice of subjects, the seating arrangements, as well as the tempting menu, rare judgment was shown. This is not surprising when one considers the circumstances under which the function was conceived. The banquet committee was composed of veterans at this particular service, men who had learned in the school of experience to avoid any mistakes that might have occurred in bygone years. They were also versed in the many little details that have aided in the successes of the past. Lem W. Flershem, A. L. Sercomb, James A. Todd, M. A. Mead, W. H. Vogell and President Dodgshun (ex-officio), who constituted the banquet committee, each in his way was of valuable assistance in making the evening pleasurable. Messrs. Flershem and Sercomb, as deans of the banquet corps, bore the brunt of the battle, and right honorably did they fulfill their duties. Another cause contributing in no light way to the enjoyment of the evening was the fact that Gustav Baumann, of the Holland House, New York, which is under the same management as Kinsley's, came to Chicago for the express purpose of seeing that the jewelers should have in every detail the service to which, as his guests, they were entitled. The personal supervision by Mr. Baumann reminded the older jewelers of the days when Mr. Kinsley himself performed the same duties, and all the desires of the guests were

attentively looked after. Under such auspices—with such a committee and such management—the highest results were to be expected, and those results were achieved.

The time of assembling was given as 7 o'clock P. M., and the promptness with which the banqueters arrived would lead one to infer that each was anxious to tell the other of his successes of the past year. As a matter of fact the element of business talk was never more absent than during the informal handshakings and exchange of greetings that preceded the march to the large banquet room on the floor above the reception parlors. These greetings were made the more interesting by reason of the number of out-of-town and city retailers present; men who have made a large success of the jewelry business and have a high standing in their several sections of the country. Added to these was a fair sprinkling of jobbers and manufacturers from other cities. It was a cosmopolitan assemblage that formed a homogeneous whole. The jewelers and their guests, led by the officers and honorary guests of the association, took up at 8 o'clock the march to the banquet hall, where they were welcomed by strains from Schildkret's Hungarian orchestra in popular airs.

Extending across one end of the room was the speakers' table, at which were seated President Dodgshun, Toastmaster Lowden and the distinguished guests of the association. At the left of the president, in order, were Prof. Emil G. Hirsch, H. F. Hahn, Rev. Thaddeus A. Snively, F. A. Hardy, C. H. Hulburd, F. E. Morse, O. W. Barrett and R. B. Gregory. At the president's right, Toastmaster Lowden, William T. Hall, M. N. Burchard, John Barton Payne, E. G. Foreman, Abraham Hart and Alonzo Wygant. Four tables,

extending the length of the room, were presided over, respectively, by James A. Todd, Lem W. Flershem, A. L. Sercomb and M. A. Mead, who were also members of the banquet committee. As soon as the guests were placed President Dodgshun called the meeting to order and the feast of things gastronomic began. The menu, an artistic production, was as follows:

MENU.		
Blue Points.		
Consomme Sevigne.	Montilla.	
Hors d'Oeuvre Varies.		
Fillet of Pompano, Hoteliere.	Haut Sauternes.	
Potatoes Persilade.		
Saddle of Mutton, Cumberland.	Pontet Canet.	
Sweet Peppers Farci.		
Jewelers' Punch.		
Breast of Mallard Duck.	Moet & Chandon.	
	White Seal.	
Salad d'Estree.		
Glaces.		Cake.
	Cheese.	
	Coffee.	
Liqueurs.	Apollinaris.	Cigars.

A feature of the banquet was reached when the jewelers' punch was served in handsome silver-topped steins, in which, Mr. Hall remarked, he could find no flaw. The steins were about four inches in height, and the pretty silver tops were engraved: "Chicago Jewelers' Association, 1900." They were carried away as highly prized souvenirs by the banqueters.

The attendance was the largest of all the banquets in the history of the association—an even 200. Large house parties were the rule and formed a pleasant feature. The Gorham Mfg. Co. party, under the leadership of Manager Ghislin, was the largest, with a total of 19, with Benj. Allen & Co. close up, with 17. Parties of over 10 were many, as a glance at the attendance, as given below by houses, will show:

**The Banqueters.**

BENJ. ALLEN & Co.—Benjamin Allen, B. C. Allen, John A. Cox, S. W. Dripps, J. R. Lilja, James C. Irwin, Fred Zeitz, G. K. Harrington, E. Kirchberg, E. H. Goodrich, C. H. Davison, T. L. Newgard, J. E. Davidson, F. D. Heffron, Chris. Morgan, A. M. Church, Julius Chislin.

C. A. ALLEN—Chas. Allen.

BARBOUR SILVER Co.—R. C. Demarest.

A. C. BECKEN—A. C. Becken, Robert Prochnow, F. E. Morse, F. P. Judson, Harry Barden, C. M. Goodnow.

COURVOISIER-WILGOX MFG. Co.—Harry Adams. DENNISON MFG. Co.—E. C. Thomas, C. E. Benson, George Remskill.

ELGIN NATIONAL WATCH Co.—C. H. Hulburd, Geo. Hunter, W. H. Cloudman, Geo. E. Hunter, C. H. Smith, G. V. Dickinson, John J. Symes, Geo. M. Harvey, J. F. Ryan, Wm. Geo. Prall.

JOS. FAHYS & Co.—James H. Donnelly.

WM. L. GILBERT CLOCK Co.—Grove Sackett, Wm. H. Stockham.

GORHAM MFG. Co.—W. V. Ghislin, Morris Berg, Will H. Beck, W. B. Holden, E. S. Hyman, A. W. Adcock, Wm. Codman, G. B. Adams, C. S. Hannan, Walter Peacock, Col. Keeler, H. P. Alsted, H. S. Hyman, C. E. Graves, E. B. Wright, R. C. Lusk, E. D. Smith, E. P. Albright, W. R. La Rue.

H. F. HAHN & Co.—Herman F. Hahn, Abraham Hart, Harry W. Hahn, Edward W. Hahn,

Jacob M. Joseph, Edwin G. Foreman, Gustav T. Bauer, Emile M. Despres, Stephen H. Bridges, Jacob Levi, Milton R. Hart, Meyer H. Lebolt.

F. A. HARDY & Co.—F. A. Hardy, Jno. H. Hardin, Chas. H. Baldwin, Almer Coe, W. C. Sommer.

ILLINOIS WATCH CASE Co.—J. Franks, M. C. Eppenstein, George Gubbins, Eugene Edelstein, F. H. Moore.

KEYSTONE WATCH CASE Co.—H. L. Roberts, H. M. Carle, C. C. Hoefer, Wm. F. Droxmit.

C. H. KNIGHTS & Co.—F. G. Thearle, Fred E. Mills, Andrew Rovelstad, C. H. Knights.

JUERGENS & ANDERSEN Co.—Henry Goldschmidt, W. G. Andersen, E. A. Rich, J. S. Townsend, Chas. Groves, Sol. Kaiser, Will Juergens, J. C. Klaholt, L. W. Bruns, H. W. Allen.

LAPP & FLERSHEM—Lem. W. Flershem, T. Zurbrugg, Col. Jas. E. Stuart, C. Dana Corbin, R. B. Flershem, Albert Jampolis, E. P. Edwards, Thos. Davies, J. Edmund Strong, A. B. Towers, C. H. Conover, F. A. Luce, H. M. Tenney, James O. Otis.

LYON & HEALY—Robert B. Gregory.

L. MANHEIMER—E. A. Moore, H. A. Sisson, E. Rothchild, A. W. Sproehle, L. Metzberg, W. A. Fulton, J. C. Manheimer, W. S. Manheimer.

G. W. MARQUARDT & SONS—G. W. Marquardt, Jr.

M. A. MEAD & Co.—M. A. Mead.

MERIDEN BRITANNIA Co.—A. L. Sercomb, J. H. Hiland, C. P. Dungan, A. N. Sperry, Geo. Meeban, C. A. Barnum, Martin Madson, W. W. Browne, Julius L. Felsenthal.

F. E. MORSE Co.—Jas. W. Clark.

NEW ENGLAND WATCH Co.—R. M. Powers.

F. H. NOBLE & Co.—H. C. Van Pelt.

B. F. NORRIS, ALISTER & Co.—C. H. Spencer, L. H. Schafer, W. B. Drackett, Thos. A. Juzek.

J. H. PURDY & Co.—J. H. Purdy.

ROBBINS & APPLETON—Ives L. Lake.

ROGERS & HAMILTON Co.—Jas. K. Caldwell, C. G. Snow.

SETH THOMAS CLOCK Co.—Robert Slade, Jr., G. W. Payson, W. J. Miller, Frank M. Sproehle.

THEO. SCHRADER & Co.—C. T. Wittstein, Edward Schrader.

SIMPSON, HALL, MILLER & Co.—H. Nordahl, J. Y. Lebolt, H. J. Racey, M. N. Burchard.

ALFRED H. SMITH & Co.—W. H. Vogell, F. S. Neely, Walter J. Buffington, Harry S. Baby.

STEIN & ELLBOGEN Co.—Max Ellbogen, S. A. Winkler, F. Le Bron.

TOWLE MFG. Co.—James A. Todd, Geo. E. Feagans, J. W. Neasham, W. M. Upmeyer, J. L. Rowe, Vincent S. Mulford, Henry Ghislin, H. D. Stevens, Chas. H. Annin.

WADSWORTH WATCH CASE Co.—Moses Loeb.

R. WALLACE & SONS MFG. Co.—Edward Tiechman, William Laiblin, Fred Hofer.

O. W. WALLIS & Co.—O. W. Wallis, A. Wygant.

WATERBURY CLOCK Co.—C. J. Dodgshun, G. B. Moore, A. B. Carson, H. F. Fisk.

G. A. WEBSTER—G. A. Webster.

OTTO YOUNG & Co.—Col. H. L. Turner, Claude Seymour, Otto Young, Julius Schnering.

ASSOCIATION GUESTS—Frank O. Lowden, Prof. Emil G. Hirsch, John Barton Payne, Rev. Thaddeus O. Snively, Wm. F. Hall, Abner Hurd.

PRESS—Stephen Parlin, C. H. Holmes, W. W. Wilcox, Edwin B. Huddle, Loren Boyle.

The substantial part of the festivities having come to a close, President C. J. Dodgshun opened the "feast of reason" with the following address:

PRESIDENT DODGSHUN'S ADDRESS OF WELCOME.

Members of the Chicago Jewelers' Association and Guests: It affords me great pleasure, and I assure you that I esteem it a distinguished privilege, to greet you once more on an occasion of this kind. I feel greatly relieved to think that whatever may be the opinion among the gentlemen present, as to whether we have just entered the 20th century or are rounding out the last year of the 19th, there can be no doubt about this being our 23d annual banquet, and that we are about to enter the 24th year of our existence.

It has been said that the tourist climbing some mountain peak stops ever and anon within some shady nook to look back upon the path he has

traversed, and to gaze with satisfaction and pleasure upon the landscape stretching at his feet, gaining thereby renewed strength and vigor for the pursuit of his upward course. We have reached one of these pleasant halting places this evening, and after the hard work incident to the Fall and Christmas business (which this season has been greater than ever), I am sure that it would be difficult to find a spot more restful to overwrought nerves or more conducive to the recuperation of wasted energies than the delightful surroundings in which we now find ourselves.

It is not my purpose at this time to more than merely touch upon two or three leading characteristics of the past year which distinguish it from its predecessors. A year ago we felt warranted, when looking into the future, in expecting that although 1898 had been a remarkably good year, 1899 would be better. This expectation has been more than realized. It has been a memorable year in the jewelry and kindred trades in every particular. As a rule all past records have been eclipsed, and where, in exceptional instances, this has not been the case, it has been due to some adverse local cause, which, even such a tide of prosperity as we have just experienced was insufficient to overcome. Furthermore, notwithstanding that a very much larger amount of business has been transacted than ever before, failures have been phenomenally few and collections exceptionally good. Our association has, we are glad to say, fully participated in the prevailing prosperity, all debts being paid and a balance in the treasury. (Applause.)

The general healthy condition is further reflected by the fact that in spite of largely increased business, the number of inquiries made by our members during the year fell off from 11,626 to 11,091, indicating less solicitude regarding the financial condition of parties seeking credit.

Just a word regarding the bankruptcy act. The past year was the first since its enactment, and, whereas, opinions differ widely as to its advantages, according as each creditor is affected by its provisions, the experience of our collection department nevertheless shows that it has on the whole been beneficial. One of its strong points is that it does away with preferences, thereby inclining large creditors to greater leniency, and frequently tiding a debtor over a temporary embarrassment. Failures have certainly, as already stated, been fewer, and although this might be naturally expected as going hand in hand with good times, their number has doubtless been further decreased by the operation of the bankruptcy act. Honest men who have been under a cloud have been enabled to wipe out past records, take a fresh start and secure one more chance to make a living. Doubtless fraudulent debtors have thus also been benefited, but not more so than would obtain under any other measure. We await the outcome of another year's experience before being confirmed in the views thus stated.

The review of the past year would be incomplete without the sad duty of noting that death has entered our ranks, removing from our midst one of the oldest, best known and most highly esteemed jewelers in Chicago, Mr. Theo. Schrader, who passed away on Oct. 30. He was a member of this Association for about five years, but unfortunately his health was latterly such as to prevent his attending our meetings regularly, so that we were in great measure deprived of his counsels; but his loss is nevertheless very deeply felt.

The outlook for the coming year is most hopeful, and although a presidential campaign is generally synonymous with an off year in business, the political conditions are such as to reduce the disturbances this year to the minimum. But we will not indulge in further prognostications. Let the near future take care of itself. We have a rich feast in store at this present moment, and to this I now invite you, not by introducing, but by presenting to you the toastmaster of the evening, known to most of you, Mr. Frank O. Lowden. (Applause.)

THE TOASTMASTER.—Mr. President, Gentlemen of the Jewelers' Association and Guests: I must admit that it was with a great deal of trepidation that I accepted this honor, as much as I appreciate it, for I did not know that I would be at home in so distinguished a body of jewelers of the west, but when I look about me and find such other eminent members of your trade as Col. Jim Stuart (applause); as my friend, Alonzo Wygant (applause); as Mr. Hiland (applause); as Mr. Barrett (applause), I feel that really I am not so much *de trop* as I might otherwise have been.

I want to say that I appreciate to the full the honor that you have conferred upon me. I real-

ize the very high principles of this organization. It is one of the organizations of Chicago which seems to work in harmony. I don't see much in the daily papers about you, and I suppose that that association which has no publicity, which has no history, is just as happy as that country which is without history, and therefore I congratulate you that you have been able to reach the ultimatum, to mingle business with social good fellowship as you have to-night and as you have during the last year. (Applause.) I am also sensible of the magnitude of this business. Why, just a few minutes ago when my friend Burchard told me—and I believe he is the statistician—I pronounce that word because it is the best test of sobriety of all the words I know (laughter)—when my friend Burchard told me that the jewelry business was the fifth or sixth in importance in this country, I looked aghast. He was surprised. He said: "Don't you believe it?" I said: "My dear friend, I am surprised it is not above that. From the bills I have paid myself, personally, in the last six months to members of your Association, I supposed it was about the first, and the steel industry about the tenth."

I was cautioned by your accomplished and graceful chairman to say to you—I assure you it doesn't come from me, because I am not going to be mean to-night—but I was cautioned by him to say to you that we must have order during the speeches, and to that end a distinguished citizen of our own, Biff Hall—I don't find his name correctly printed on the menu—was invited to be present, and any man who shows any sign of disorder during the evening will kindly present my compliments to Mr. Biff Hall at the 35th St. police station to-morrow morning.

I can understand the joy you must have in hearing again our good friend Emil G. Hirsch, the most brilliant orator, I think, I have heard in Chicago, without exception. (Applause.) For 17 years he has not missed a banquet, I am told, and last night at 12 o'clock left Detroit in order that he might be with you now. You have seen his subject on the programme. You gentlemen deal in jewels, but of all the men I have known Dr. Hirsch is best fitted to think, to speak jewels, and be is going to talk to you to-night upon the "Jewels in the American Flag." I say to-day, as a citizen of Chicago, that if any one of our people of this great city by the inland sea has done more than another to add luster to the American flag it is the speaker whom I am about to present, Dr. Hirsch. (Great and long continued applause.)

ADDRESS OF PROF. EMIL G. HIRSCH.

Your president, friends, told me that the new bankruptcy act precluded preferences. It seems I am out of the pale of the benevolent action of that act, for undoubtedly you still continue, without sufficient reason, however, to show preferences—to invite me year in and year out to your banquets. If my speeches were only a quarter as good as the cheer that you set before us I could understand your partiality for me, but as it is, for once I must doubt your sanity and your judgment.

Pat was about to die and sent for father confessor. He told him that he had an especial request to make, and that he could not die peacefully until the father had promised him to see to it that his dying request be executed. "Well, what is it, Pat?" "Father," said he, "promise me that after my death I shall be buried in a Jewish graveyard." "Why in a Jewish graveyard?" said the father confessor. "Well, don't you see, father, a Jewish graveyard is the last place where the devil will look for an Irishman." (Laughter.) I believe if the devil should take it into his head to look for me he would look for me at a jewelers' banquet. (Laughter.) I have been with you probably 17 times, and I have come no nearer being a jeweler than I was when I first came among you. Then I had the right to claim the first syllable and I have not advanced any further up to the present time. (Applause.)

I was asked to talk on my own subject. I thought that I might give you a discussion on the problem of in what century we are now living, but I find that in Chicago and in Germany, with us the Czar Kohlsaas, and in Germany, the Emperor William, have decided that question. (Laughter.) I went over the reports of my former speeches, and I discovered that I had about exhausted every subject within the range of human knowledge. I took you from Assyria to Egypt one time, and from Egypt into the Middle Ages and I landed by Lake Michigan. At another time I went into a political discussion. To-night, therefore, I thought I would speak of the jewels in our beloved American flag.



GEO. B. KELLY

MORT. MCG. BURCHARD

A. L. SERCOMB

W. G. ANDERSEN

PAUL JUERGENS

W. F. JUERGENS

JAS. K. CALDWELL

JAS. A. TODD

G. A. WEBSTER

OTTO YOUNG

JULIUS SCHNERING

GEO. WEIDIG

H. F. HAHN

R. C. BECKEN

F. A. HARDY

WM. G. PRALL, Sec. & Treas.

J. F. TALBOT, V. Pres.

GEO. H. EDWARDS, Kansas City, Mo.

HY. SLDANE, Kansas City, Mo.

CHAS. A. ALLEN

R. L. HOGARTH

J. P. BYRNE

L. W. FLERSHEM

PETER LAPP

M. LOEB

NOAH CLARK

JAS. W. CLARK

LOUIS MANHEIMER

C. J. DODGSHUN, PRESIDENT

W. J. MILLER

F. C. HAPPEL

M. A. MEAD

CHAS. LESTER

GROVE SACKETT

J. H. PURDY

W. H. VOGELL

I. L. LAKE

GEO. G. GUBBINS

E. A. MANHEIMER

R. C. DEMAREST

R. E. KEHL

F. A. NOBLE

BENJ. ALLEN

H. M. CARLE

R. A. KETTEL

A. H. WITTSTEIN

THEO. SCHRADER

CHAS. T. WITTSTEIN

R. W. MORRIS

C. H. KNIGHTS

G. W. MARQUARDT JR.

G. W. MARQUARDT SR.

C. M. P.

C. A. A.

Gibson - Forrester & Photos

— 1899 Members of Chicago, Ill —

Eva & Co.

The one bright star in that flag stands for opportunity, beams out upon the night with the promise that whosoever shall utilize talent and time under the folds of that flag will be rewarded for his efforts. If one studies the past of America, he is struck especially by this phenomenon, that all the people who have come here accidentally, by birth, and intentionally, by immigration, have displayed, after falling under the influences of our glorious climate and the contagion of our spiritual atmosphere, a decidedly optimistic temperament. We had in this country no ruins to remind us that splendor was behind us. Our hills were not crowned by castles, fabled in song and famous for the valor of their now dead earlier occupants. Not looking backward, we had to look forward, and in this faith in our destiny and by the magic of our confidence that the future would realize what in the present we were striving for, we changed deserts into paradises; boweled the very depths of the sea in order to find a channel for our ambition. We linked the rising sun to his setting by iron bars, across which traveled on the wings of lightning our best thoughts and the productions of our noblest endeavors. Within the last decade, however, this spirit of hopefulness seems to have begun to wane. Voices have been heard in our country telling us that, as in Europe, so here, the fruitage of life falls to the exclusive possession of the few, and that the many are doomed here, as they were in Europe, to toil without reaping; to plant without harvesting. We have been told that we are on the verge of abandoning the fundamental principles of our political system; that what the fathers wrought in the earnest consecration of their early political faith we have begun to forget; that in order to open new channels for those that would accumulate millions, we, too, have drawn the sword, and not satisfied with the boundaries built by God's own hand wherein to frame our free and noble land, we have crossed the seas in quest of adventure, driven thither by the greed and the passion for gold and the hunger for martial honor.

I beg you, friends, to resist the insidious lures of this spirit of despair. Your own business experience will have taught you that if men begin to disbelieve in others and in their own

ability; when men begin to shout calamity, they invite the very disasters of which they stand in dire dread. A few years ago the panic was largely of our own making. We were in the grasp of a national hysteria. We allowed ourselves to listen to the tale of woe and under the insidious hypnotism of our own forebodings, we forgot to use our hands and employ our brains to meet whatever untoward circumstances the changing in tides of commercial currents may have brought to our very door. Let us not, whether it be the last year of the 19th or the first one of the 20th century, forget this lesson. Let us look up to that star, the jewel in our flag, which beams out with rays of hopefulness. I for one do not believe for one moment that we have forgotten the virtues of our fathers (applause); I for one cannot subscribe that under our political system ever a day will dawn when the few will rule and the many will slave; I for one cannot concede that our flag has crossed the sea, impelled to unfold its glorious furls merely for the sake of opening new territory for speculators and carpet baggers. (Applause.) As I read the events of the last few years, I am confronted by the lesson often emphasized in history, that the nation that goes to war never can tell at the beginning what obligations may arise out of defeat or even of victory. Men must shoulder the obligations that come to them in the course of their eventual career, and so must nations. The nation that invites the fitful decision of battle cannot shrink from whatever responsibility may have grown out of victory in the hour of its triumph. (Applause.) We began a war for the sake of liberating millions held in bondage. In the pursuit of that war it fell to our duty to reduce by whatever honorable means were at our command the power of our opponent. Having done so we became under God's own decree the guardians of seven millions of brown men. (Great applause.)

Not knowing what our flag signifies, and probably goaded on by such as artfully speculated upon their ignorance, some of these seven millions have drawn the sword. It is a painful duty that is upon us but we must face the obligation. We are responsible, not merely to our own selves, but to the world at large, and unless we do our task now, what so many fear will come to pass,

will be a certainty of the immediate future. Unless we protect them the world, the non-American world, will soon, under one pretext or another, sail up the glorious bay made famous by our own navy for all time to come, and lay heavy hands on Manila and on the archipelago. (Applause.) Thus, there was but the one alternative: Either our flag, the flag of promise, the flag of liberty; or the flag of Russia and England and Germany. And could there be any doubt under this appointed alternative? I for one hold the choice was pre-ordained in the decrees and the goodness of Providence. Let our flag float over that archipelago until those seven millions of brown men shall have been taught by us the purpose of liberty, and when they shall have become able to imitate our glorious example. Then, perhaps, it will become our destiny to give them at home the freedom they deserve, while, in their relations to the outer world, we, the stronger sister, shall hold over them the shield of our might and give them the honor and protection in their intercourse with other nations which goes forever with the glorious flag so full of jewels, our own beloved flag. (Applause.)

Nor is it true that the luster of that star, tokening hope and speaking opportunity, has been dimmed by the economic and industrial conditions now prevailing in our own lands. We are now passing through a critical period. One system of industrial action has about run its appointed tether, and we are groping upward toward the inauguration of a wider and more comprehensive scope of industrial economy and of commercial relations. Whenever a critical period is upon the community many are they who lose their firm footing. So it was when the railroads came. They replaced thousands and thousands who had earned an honest livelihood by carrying the mail and transporting goods and passengers on the slow axles of their coaches and wagons. Will any one of us say what was said then, that the railroads have been among the forces making for the increase of human misery? Certainly not.

And so as we pass now out of the competitive age to the epoch of closer co-operation, naturally many there are who during the years of transition feel that they have lost their security and perhaps must bring great sacrifices. But it is as

# There is no Tattoo but the New Haven Tattoo.

## Write for Our 1900 Catalogue.

The Tattoo Alarm has made thousands of friends for us. It will do the same for you.

If you do not carry them in stock, order at once.

## New Haven Clock Co.,

149-151 State Street,

CHAS. LESTER, Western Manager.

CHICAGO, ILL.



# For Over A Third of A Century



THE ELGIN Watch has sold on its merits. Through all these years its guarantee has been as good as gold, and though the years have come and gone the name ELGIN still stands the synonym of all that is excellent in the production of timekeepers.

Every jeweler knows that ELGIN Watches are watches "with a reputation." They now stand before the world as the finest example of high-grade watch building. There is no name so widely known among the buying public in connection with watches as "ELGIN." There is money for the retail jeweler in handling watches bearing it because there is no trouble in selling them, no suspicion about the make or their timekeeping qualities, no need for explanations or guarantees to induce the consumer to buy them, no left-over stock on account of faulty construction or poor running qualities. Nothing is left to chance. ELGIN WATCHES are best because they sell on their merits. If they were not the best we would not have the courage to constantly advertise them.

In this connection we wish to extend to all the trade the compliments of the season, wishing you the most prosperous times in 1900, and pledging ourselves to aid you in every way possible in selling the World's standard among watches—THE ELGIN.

## ELGIN NATIONAL WATCH CO.

Factories, Elgin, Illinois, U. S. A.

General Offices, 76 Monroe St., Chicago, Ill.

New York Office, 11 John St.

futile to believe that by legislation we can change the law of gravitation as it is to hope that by the fiat of Congress or of Council we can arrest the onward movement of industrial and economic progress. What we must do is to study conditions and to adjust ourselves to them. And I say that every merchant who studies the conditions and takes his precautions accordingly will find that America, even at this period, is still the great country of opportunity. And I say that as our economic knowledge spreads abroad and our economic maturity becomes of a stronger, finer, ever-widening nature, they will learn to adjust themselves to the new conditions. That in this age of transition there are certain evils I am the last one to deny, but these evils are merely incidental and not essential, and these evils will be most speedily neutralized in a government of the people, by the people and for the people. (Applause.)

Publicity, the open, outspoken criticism which drags everything to the light of day, is the best antidote for the germs of pessimism. Apply that principle which the doctor of medicine knows to social and economic conditions and half of the obstacles are removed. Whatever may be said about the great combinations of capital or labor, they are necessary phases in the economic development of the 20th century. Publicity will largely rob them of whatever dangerous elements they may hold, and 50 years from now our grandchildren will wonder that in the last year of the 19th or the first year of the 20th century there were men that thought these necessary tendencies of a time fraught with great perils, just as we wonder that there were men who 50 years ago pleaded that the railroads were fraught with evils and were the harbingers of great commercial and industrial disaster. Let us merely be hopeful and strong, and whatever the future may bring to us we shall be able to cope with it and to triumph over it. Industrially and economically as little as politically is America doomed to slow decadence. It is still a young giant; the meridian line of its life has not yet been reached. Let us climb upward and onward, and in the 20th century we shall crown with greater luster the edifice left to us by our great and noble and devoted and heroic fathers.

And there is another star, another jewel in the flag; its name not religious tolerance but religious respect. "I have the utmost contempt for the man who is tolerant. I do not wish to be tolerated. I remember a time when I used to be introduced as a sort of curiosity, an archaeological specimen, which by rights ought to have gone to sleep 1800 years ago, but that somehow or other refused to die or fall asleep. I remember that liberal people used to trot me out at their meetings simply to serve as a peg whereon they could hang their thread-worn cloak of assumed liberalism. I remember the day when I used to be heralded as welcome to a platform which was large enough and liberal enough even to allow a Jew, and generally a colored man with me, to stand thereon. (Laughter.) That was the spirit of tolerance. If I am merely to be tolerated then I am an unmitigated nuisance. I may in my personal character be such, but in my representative character I do not like to be labeled virtually an unmitigated nuisance. But the spirit of tolerance, thank God, has died, and under the folds of our great and glorious flag we have learned not to tolerate our differences, religious, political or otherwise, but to respect one another all the more on account of these differences. (Applause.) It is just like what the good old brother in a Methodist meeting said when the pastor explained that the Lord made men and women, but with a slight difference. He exclaimed, "The Lord be blessed for that difference." (Great laughter.) And so we bless the Lord for the differences that divide and differentiate one from the other. The higher the civilization of men, the more individualized are the different men.

You cannot tell the savage races one from the other. "All coons look alike to me" (laughter), yet is a universal law, and wherever religious bigotry still obtains all Cohens look alike to the others, too. But the higher we proceed the stronger the law of our individuality, and still, though preserving our individuality, we can all co-operate, and nowhere on the face of God's earth is this zeal to co-operate, not at the expense of differences, but with the differences emphasized, so strong, or has it born such rich fruit as here under our own glorious flag. May, then, that flag wave forever. (Applause.) May

that flag continue to display the jewels of the night on a cushion of blue taken from the sky. May forever wave out in significant message the ribbons that we have asked the morning dawn there to embellish the jewels on the cushion of blue, and may never the day come when the least blemish and smoke detract from that other color in our national emblem, the color which God himself bestowed upon the flag to indicate that the jewels on the cushion of blue fastened with the flowing bars and the morning light were meant to be the bringer to all the earth of peace and justice, liberty, life and love. (Applause.)

Three cheers were then given for Dr. Hirsch and the orchestra played the "Star-Spangled Banner."

THE TOASTMASTER:—I want to qualify a statement I made a few moments ago. If distinction in oratory means not simply rhetorical graces but a brave conscience and a big brain and profound thought I did not state the truth when I said Dr. Hirsch was the principal orator of Chicago. I should have said of the country. Now I hope that you will excuse me and pardon me if I propose in the name of this association a toast to Dr. Hirsch, and ask you all to drink to that toast standing, and that toast is, "May he for 17 years more each year be with this association." (Applause.)

The toast having been drunk standing, the toastmaster continued:

Now, gentlemen, there are a few of you—though maybe only a few—who will not be eligible to call on "Biff" Hall to-morrow morning, and therefore he has come here to see you. You are about to listen to a man who presides over a police court, and brings more dignity to that than the average man would to the Supreme Bench of the United States, because of his great common sense, good judgment and his sympathy with those who have to resort to courts of that degree to secure justice. Mr. "Biff" Hall.

ADDRESS OF HON. W. T. HALL.

Mr. Toastmaster and Gentlemen: As a text I would like to call your attention to the saying which may appeal to those of your craft, that

# Seth Thomas Clocks?

## Yes, they Sell.

### From your Jobber or

144 Wabash Ave.,

Chicago.

49 Maiden Lane,

New York.

# JUERGENS & ANDERSEN CO.,

92 to 98 STATE STREET,

CHICAGO.



**IMPORTERS OF . . . .**

## Diamonds

And Precious Stones.

## Mounted Goods.

We are also showing an extensive line of new designs in **Pendants, Rings and Emblem Goods**, and invite the inspection of the visiting trade.

**SPECIAL ORDER WORK IS AN IMPORTANT  
FEATURE OF OUR BUSINESS.**

speech is silver and silence is golden. (Applause.) If you will kindly give me a little of the golden I will be much obliged. \* \* \*

I suppose I might at the outset explain the sentiment to which I am to speak, "Flaws in the Stein," and I don't mean this stein (referring to the souvenir, which was given to each guest at the banquet); I am simply using the vernacular. You know that Chicago is sometimes referred to as the gem of the great lakes, and as we are all loyal Chicagoans very few of us would be willing to confess that there are any flaws in this city. There are a few. They are not visible to the naked eye, but you may discover them with a glass. The more glasses you take the more flaws you discover. (Laughter.) I wish to say in passing, however, that this remark does not refer to the delegates from Evanston and Hyde Park. The flaws exist principally west of State St., and during an experience of 15 years on the daily press and the subsequent five years in the police court I have discovered a few of them.

Now, I know you gentlemen don't care to hear anything about your own craft. You have troubles enough about that every day, and from the looks of the gentlemen present I don't believe they know very much about a police court. I have had a few gentlemen up there in evening dress, but they have been up all night, and I think possibly I might interest you with a few little so-called gags about life west of State St. in the nature of police court stories. I have presided for five years over the court at 35th and Halsted Sts., in the stock yards district. It sounds very bad, but it isn't as bad as it sounds. It extends over a good deal of territory; that is, we have the territory covered by the limits of State St. and Ashland Ave. and 16th to 55th St., and you see we have a very wide territory to draw from. We have all sorts of people and all sorts of nationalities. No doubt you read a while ago about the ambitious young woman who had been reading the works of Laura Jean Libby and the Duchess, and who raised a few stock yards' checks in order to purchase a Gainsborough hat, and several of the ladies who go to the Woman's Club and lecture on society interceded for her and she was released. The other day I had something of a parallel case of a

young girl of about 16, brought up charged with stealing a \$20 gold piece from a woman for whom she worked, and she had changed it and bought jewelry to the value of \$11.40 on Wentworth Ave. Some of the jobbers here present may know how much jewelry you can buy on Wentworth Ave. for that price. The young lady came into court adorned with this jewelry. She had alleged rubies and alleged sapphires and alleged diamonds, and, in fact, she looked like a chorus girl who had a gentleman friend, and we talked the matter over in a quiet way. (Laughter.) There were others present, and I directed the sergeant to take the jewelry from the young lady and return it to the retailer on Wentworth Ave. and secure the money back, and, by a sort of a—well, I don't know what you might call it, sequence, such as the House that Jack built—the lady finally received back her \$20 gold piece and forgave the young girl. That was better than having an intercession by the powers that be in society.

And those things come up all the time. Little problems which simply the exercise of a bit of common sense may remedy. I think that it is the duty of every man, every taxpayer who is interested—of course, the taxpayer cuts a very wide swath now since the decision, but every taxpayer should visit the police court in his district or any other district. I think he ought to know what is going on. You read in the papers about so and so being fined and so and so being discharged without knowing why. I think it is the duty of every man who is interested in the city, because that is a part of the city, to go into the police court, and I invite my friends always to come over there and see what is going on. \* \* \*

THE TOASTMASTER: Gentlemen, I suppose you appreciate the appropriateness of the piece which the orchestra has just played, "A Hot Time in the Old Town To-night," after my Brother Hall's speech here. The next speech will suggest improvements for all the defects which have been pointed out, and, by the way, I am requested by the president to say that a flashlight will be thrown upon us a little bit later, and it is hoped that everybody will be here to come within the focus of the camera. It was not thought best to have the picture taken just now. Dr. Snively, who is going to respond to the next

toast, and who is one of the most accomplished gentlemen in Chicago, wrote to the chairman of the committee, and said he hoped his speech would come early in the evening on account of his profession, not being used to this sort of dissipation, that he made a much better speech early in the evening than late in the evening. The chairman of your committee, with his accustomed quickness, replied that before a jewelers' banquet the later a speech was made the more successful it was. I now have the pleasure to introduce to you Dr. Snively. (Applause.)

ADDRESS OF REV. THADDEUS A. SNIVELY.

Mr. Toastmaster and Gentlemen: This is a case of misrepresentation. First I want to warn you that I am not the flashlight, and secondly, I was told that the speeches began about 1 o'clock in the morning at the Chicago Jewelers' Association. I have seen Dr. Hirsch, and I supposed it was just after a banquet of the Jewelers' Association. He had a careworn look in the morning. I have seen some of the jewelers likewise, and so perhaps I was somewhat deceived. This is my first appearance, the first time that I have had the honor of attending one of these banquets, and I came with a good deal of trepidation, and I confess my position is somewhat that of one of the individuals in a story which may be familiar to some of you. If so you must laugh just the same as if you had never heard it before. The story is that in that confessional box with which Rabbi Hirsch seems to be so familiar, there happened to be a young man making a confession, who said that he was an acrobat, and he said: "I made some flim flams in front of your reverence's house." Well, the priest didn't quite understand that, and said: "My friend, what is a flim flam?" "Well," he said, "I can't explain, but I will show you." So he went out of the box and turned a few handsprings, and went in and knelt down, and the reverend father was somewhat troubled to keep from laughing. The next person was a woman of about 240, and she said: "Your reverence, I hope you won't give me such a penance as the last man, for I couldn't do it to save my life." (Laughter.) When I heard Prof.

Write for our New Catalogue.

# The New England Watch Co.

WESTERN OFFICE AND SALESROOM,

149-151 State Street,

Chicago, Ill.

CHARLES LESTER, Western Agent.

Hirsch, with his beautiful language, appeal to the serious side, and then the Justice presented to us another side even more serious, I felt that after all it was rather a difficult position to fill, so I beg your forbearance while I go on to say the few things that I have.

I do think, my friends, there are needs in regard to Chicago that are local, and yet they may be the general needs of the whole country. Now, on that one subject, on which our first speaker spoke, which I take is the highest idea, patriotism, there is need in Chicago. We are not citizens of Chicago but of the whole country, and we have to think of every subject that comes before us as something that is to touch every human being in this great country, extending, as it is, far beyond the western coast of California, even into the distant Pacific—I say we must remember that every question that comes before us of an ethical nature is not simply to be decided by its relations or its bearing upon Chicago, but by some larger and more extended view of the same. We are so apt, we voters, to think of a man in relation to Congress, for example, or even with regard to the Senate, as a man that can be useful to our State and our own district, or perchance, useful in some little measure to people personally, or in a group whom we may have in our minds. We don't get the highest statesmanship in that way, because we have a low type of citizenship, and that flag, that was painted with such beautiful language, can never wave in its full glory or cast its broadest glow upon this country unless we rise to a higher and a loftier ideal of citizenship. (Applause.) Now, my answer to that subject is, that we need ideals in Chicago, and bringing home that question of citizenship, I think we need a higher ideal of American citizenship. Now, we don't expect changes instantaneously. That is the trouble. We elected an administration here, and the administration and the city government take a step forward. It is a splendid thing to take a step. The great ocean has its tide, but there is the ebb tide as well as the tide of its fullness. But there is the onward advance of the ocean, and so with regard to the elevation of citizenship. There has to be an ebb as well as a flow, but in the end they reach a higher level, like some great lake or

some great inland sea that is continually rising in its height. So it is with the local advancement and improvement of a city, to my mind, which is the result of the aggregated advancement of the citizen's life. We cannot hang back and look at the whole thing in a scoffing way, or simply take the parts of critics unwilling to do anything, and expect that there is to be an advance, but here in Chicago we have to watch every point. It is like a great many things in life. You will find that those who are consulted and have a tremendous interest of their own exercise a tremendous influence. And so with every issue in the civil life, there are many that are consulted so that their will is felt, because they have a selfish interest back of it, while the ordinary citizen is scattered into groups, or in the individual life, and so the power is somewhat dissipated. The only way is to have a higher ideal, and the true ideal of citizenship, my friends, is not achieved simply by our listening to even the noble words of such a speech as we heard to-night, but it is by doing the little that we can do in every opportunity that is presented to us in our political surroundings. (Applause.)

Now, then, another ideal that I think we need to follow out in Chicago is the ideal of the business man. I have heard it said that Chicago is the second greatest city of the Union. It is in population, it is in influence and it is in possibilities. With regard to wealth it is unquestioned. I suppose, on account of our marvelous situation, with the railroads in such large numbers coming here by compulsion, that gradually the indebtedness to the east and to the foreign countries from which, no doubt, in the past, much of our wealth has come in a broad form—gradually that wealth will be paid back, and Chicago, if not today—I am not prepared, because I am not a statistician, to say, but some of you would know, whether Chicago really has achieved the position of being the second wealthiest community in the country, but it is going to be. The star of empire westward goes, but stops at Chicago. (Laughter.) It is going to stop here for a long while because, as you view this country over, as it grows larger and larger, it will be impossible to keep the center of commercial activity and financial power on the seaboard. Of course that

may be a mistaken prophecy, because railways will annihilate distance, and the telegraph, too, so that we are at work with the long distance telephone whispering into the ear of our neighbor even though we be separated by a thousand miles or more. But it does seem that Chicago is to have more and more prominence in this great country, and therefore we need a high standard of official life here in Chicago. I am not speaking of dishonesty or that; I am speaking of a high ideal toward which we must aim. Now, the idea that we have before us is not that which we always reach. You know in your own lives, as you have thought of the future, you have pictured yourself, perhaps, a great success, in some ways, far greater, far more beautiful, far sweeter than the success that you have achieved. There is not a man in any profession that has not an ideal, or at least that ought not to have an ideal, that is away beyond that which he will be able to achieve. The man who shoots at the sun is the one that will reach the furthest distance off. Now, I think that just at that point, as I stand here among you business men, with my friend Rabbi Hirsch, I feel that I represent another side of life, and I believe into your ideal of commercial life you have to bring another idea. I believe that it is religion that helps to build up the highest species of idealism. In other words, I don't think that you can get a man to reach the highest ideal without religion. Man by nature is selfish. It is religion that furnishes the highest idealism, because it gives optimism to the race. Of course, I have my own religion, that is most dear to me; it is a daughter of that religion which my brother to the right represents, and I want to say that it is a religion that respects its mother.

Now, I think that all kinds of religious thought that helps men to lift their ideals, that helps to elevate the importance of the moral tone of the community, that even at times can teach us that self-sacrifice is a nobler virtue than gain—I say any influence of that kind that comes into a community is a most important influence if we are going to reach the highest point. And so, in asking you to be idealists, and having the highest optimism of the race, let me say to you that I believe that we cannot reach the highest

# MACHINERY

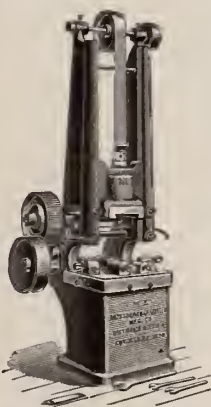

No. 5 Automatic Drop Press.  
Made in 12 Sizes.

**UP TO DATE** is what enterprising Jewelers and Silversmiths want and must have in order to do business in a satisfactory and profitable manner. For years we have made a special study of the wants of the Jeweler and Silversmith, and are prepared to furnish the best designed

**DROP PRESSES,                      ROLLING MILLS, Fitted with Roller Bearings;**  
**FOOT PRESSES,                      ROTARY SHEARS,**  
**HAND PRESSES,                      INGOT MOULDS,**  
**POWER PRESSES,                      LAP LATHES,**  
**COINING PRESSES,                      WIRE COILERS,**  
**WIRE POINTERS,                      DRAW BENCHES.**

## MOSSBERG & GRANVILLE MFG. Co.,

NEW YORK, 126 Liberty St.

PROVIDENCE, R. I.

Philadelphia Bourse.

WESTERN OFFICE: Mercantile Bank Building, Cleveland, Ohio.

ideal unless we begin something that is really unselfish. Now, in the Jewish traditions, and that sacred book which belongs to the Jewish faith as well as the Christian, the Old Testament, we find—there are people that were taught that one of the most important things that they could do to show their interest in the advancement of their own people, was the duty of giving. And it is one of the remarkable things that the tithing, as it is called, the giving of one-tenth, was that which was the secret of the great power of the Jewish people at the zenith of their material glory. Now, when we think of the achievements that are before the American people, I appeal to you, my friends, as representatives of one of the noblest crafts and trades of the world—I use it in the highest sense just as I would of my own work—to remember you have responsibilities to the American citizen, that it is in this country that the American citizen has to do what the lordling and the nobleman and the man who had great estates did in those old countries. We have no great families that date back a century or two. We have no great vested estates that go from oldest son to oldest son, so that in building their castles they may also build the church or the orphan asylum, but we have to depend on the individual citizen, and so the more we can spread this idea of responsibility upon the individual with regard to the giving of these splendid gifts for the entertainment of the race or the alleviation of human misery, the protection of the young and the weak and the caring for those who are in need, I say that the more we impress that upon the American citizen the greater our reward is to be. (Applause.) Now, let me say just before I close, that that is not something that we are to give over to the man of great wealth like the Vanderbilts or the Goulds or others. It is something that we must each attend to in our individual place. There are works that you men can help to do. There are associations for helping the needy and the protection of the sick, and for responding to those calls which you individually would have, and cases of need which perhaps you do not give to because you do not see the need and do not feel it as some of us do. To make an appeal at this moment, perhaps, may be unfitting, but I trust you will forgive me if it is in

interest of the charities and all the works for the alleviation of human suffering in this great city. That is one of the greatest needs of Chicago, and permit me just to add why I think so. I have been in Chicago seven years, and I feel as if I were a Chicagoan. We are gathered here—I don't know how many of you are natives of this heath—but we are gathered here from all parts of this country and from all parts of the world, and we come here all thrown into a little place, and sometimes do not feel the touch of these greater demands, and therefore do not feel the responsibilities that rest upon citizens of this great city, and we have to make every effort that we can to gather ourselves into that one feeling that we are citizens of a great city, and that we are therefore responsible for all the needs, whether it be the needs of the Government or the needs of the suffering individual, and that we are going to try and help on so that in the end Chicago may be great, not simply in material prosperity or in the accumulation of wealth, but in the tenderer, the more gracious, the more divine-like sides of human nature. (Applause.)

I thank you, gentlemen, very much for your kindness in listening to me this evening. It is very embarrassing not to be able to present things in a more striking or pleasant way, but I am sure that if your appreciation of the few words I have said to-night is one-tenth as strong as my appreciation of the kindness which was shown in bestowing this honor upon me I shall be more than gratified. (Great applause.)

THE TOASTMASTER: Apropos of the speech of Dr. Snively, I want to call attention for the benefit of those who are not members of this Association but who are guests, that one year under the inspiration of this motive so eloquently and earnestly portrayed by Dr. Snively, the Chicago Jewelers' Association passed its annual banquet a few years ago in order that it might contribute \$17,000 to the needy of this city and this country. (Applause.) Genial and joyous as you are to-night I want these guests to know that you are not unsensitive to the sufferings of those less fortunate than yourself.

I now have, gentlemen, a painful duty to perform. I remember a few years ago when the next speaker was one of the most eminent judges in the country, when his justice, when his pro-

bity, when his sense of right and when his ability distinguished him above almost all men upon the bench; I remember that he was one of the most effective advocates in the west; I remember when he was one of the most sought after orators in the State, but now his principal claim to distinction, and the only name by which he wishes to be known is that of the best golf player of the Midlothian Club. I trust, however, that my good old friend, erstwhile famous judge and brilliant advocate, John Barton Payne, is about to return into civil life. We have, some of us who are here, wanted to vote for him for all kinds of offices, and I see that he is beginning to get ready to get back into public life. His subject, as you will note, is "The Twentieth Century Man." He holds, with Czar Kohlsaar—I think you called him—and the Emperor William, that the 20th century has begun. He intends to get the German vote, gentlemen. I have the honor and pleasure of introducing to you the Hon. John Barton Payne.

ADDRESS OF HON. JOHN BARTON PAYNE.

Mr. Toastmaster, My Friends: I don't mind confiding to you at the very outset that I do not at all agree with Emperor William, or for that matter with Czar Herman, but I may say that I will settle the question for you once for all. The twentieth century has not yet come. Perhaps that is because the gentleman whose advocate I am to-night may be personally present. If any of you recognize him in the few words I shall speak to you then you may say that he is ready to begin with the twentieth century, and by the time your next banquet is held he will be here in full force, not alone, but in billions.

My theme is the most noble of all themes. The flag is but an emblem of glory and patriotism. The city is but the dwelling place of man and its needs are passing needs. But man, whether he be the twentieth century man or any other century man, is the noblest work of God. (Applause.) I have been struck by what has been said here about religion. All honor to religion, but according to my conviction, there is in the manhood of man, in the character of man, a nobility, a personality, a magnificent possibility, that cannot be circumscribed by any known religion. (Applause.) Religion is the expression of man, because it is man's conception of a Deity. It is our humble effort to express a diviner personality, a nobler life, a living entity. But man himself, when he is a man, when he walks uncrowned, except by the dome of heaven, and stands out an honest man, a man of truth, a man of probity, a man of noble impulses and inspirations, comes closer to God than any of his conceptions of God. (Applause.) What is the twentieth century man to be? He is to be a patriot. He is to have a large conception of human things. He is to be absolutely incapable of firing upon the backs of American soldiers anywhere. (Applause.) When the United States shall have spoken by its constituted authorities, the twentieth century man will follow that edict and lay his life in the balance, either at home in the defense of our policy and our purposes, or by carrying the gun; wherever his station or calling will be, his voice will be for America as she is. (Applause.) The twentieth century man will be an honest man; he will not be a time-serving man; he will not advocate the passing policy because it may be the policy. He will endeavor to go to the heart of things, to know the truth, and knowing it dare follow wherever truth may lead. In business he will deal with all men justly. He will not misrepresent his wares. He will stamp his name upon his wares, and when that name is stamped that article is what it purports to be. (Applause.) And whether he sells jewelry in Chicago, or deals with the commerce of nations and sends his wares from sea to sea protected by the American flag, still his name, wherever that name shall be, will stand for honesty, for truth, for what it appears to be and not what it does where the American name is not respected. We have now taken our place among the great nations of the world. It is not a question as to whether we ought; we have. It is not a question whether we ought to be; we are. The fact is established, and whether all men agree with that fact or not, it is as much a fact as the existence of the world. Now the purpose of the twentieth century man shall be to make the American name a symbol everywhere for honor and integrity. There is no disguising the fact that many men of intelligence living in Europe, and in other quarters of the globe, look upon our aggression as a change of our national policy and accuse us of insincerity in dealing with these great questions. What is our answer to that action? Our answer is that our conduct, our treatment of na-

HEADQUARTERS

For....  
Everything

Used by  
Jewelers.

SEND  
FOR  
PRICE-  
LIST.

THIS  
WILL BE  
A  
GOOD  
WATCH  
YEAR.

Cross & Beguelin, 17 Maiden Lane, N.Y.

tions, our keeping of our obligations, our trade integrity and trade name, must be kept so high that a George Washington must look upon it and say, "I approve it." (Applause.) Ours has been a nation of ideals; of ideals in government; ideals in politics; ideals in social life, because we have the best social life of the civilized world. Marriage means more here than in any country on the globe. Politics—we deride politics simply because the name has come to have a mistaken synonym. We must correct it. Lincoln was a politician; George Washington was a politician; Daniel Webster was a politician; Alexander Hamilton was a politician; Thomas Jefferson more politician than any of these men; why should not we be politicians? Simply because we have mistaken the name. We think now they were statesmen. That is because they are dead. Politics means the life of a republic, because every man in it is a politician if he is a patriot. I say that politician and patriot are synonymous, and if we would be what we ought to be, and express what the twentieth century man means, we must accept the definition and be proud of the name. (Applause.) So I say that the twentieth century man means an honest man, a plain, frank, outspoken man; a man who shall carry the flag and carry commerce and do the business of this great country with all the world and yet maintain that beautiful, simple honesty of purpose that we so admire and love among our friends. (Applause.)

Judge Payne's speech closed the evening's entertainment.

To the musically inclined the melody of the Hungarian Orchestra was a treat, and especially so the mocking bird imitations given as a solo by the leader as first violin, with full band accompaniment. This selection was encored again and again. Special arrangements had been made for the band to give appropriate selections between the speeches, which was an enjoyable innovation that should be repeated at future banquets. After Prof. Hirsch's eloquent discourse on expansion, the orchestra played the "Star-Spangled Banner" amid great cheering. After the Hon. "Biff" Hall, "A Hot Time in the Old Town" was thought the thing. Rev. Mr. Snively would have a church full to overflowing if the sentiment of the band, "I'd Leave My Happy Home for You" were followed by the audience that heard it last night. John Barton Payne's masterly talk was followed by the parting song, "Auld Lang Syne," and then, at 11.30, the guests withdrew and the 23d annual banquet of the Chicago Jewelers' Association passed into history as one which had surpassed in all respects the high aims of the committee and had been full of snap from start to finish.

THE JEWELERS' CIRCULAR reproduces a large photographic group of the members of the Chicago Jewelers' Association. The group comprises 56 of the members, being all but one of the firms in the Association, that one having made a change while the work was in progress. The negatives were taken by Gibson. George D. Evans was the group artist. The arrangement is exceedingly artistic and the likenesses are perfect. The picture, which is three feet six inches by five feet, has been hung in the rooms of the Association in the Columbus Memorial building, and produces a very striking effect. It attracts a good deal of attention and is one of the most interesting features of the rooms. The following letter from President Dodgshun is warmly seconded by the members:

CHICAGO, Jan. 5, 1900.

Messrs. Schluter & Evans, Chicago.

GENTLEMEN:—I take great pleasure in expressing my unqualified satisfaction at the group picture of the members of the Chicago Jewelers' Association, which, after a great deal of trouble and

persistent effort, you have finally succeeded in completing. I know, furthermore, that all our members are greatly pleased with it. It comes up in every respect to the representations you made when we placed the order with you, and is in every way a success.

Yours very truly,

C. J. DODGSHUN,  
President Chicago Jewelers' Association.

### Banquet Notes.

Manager Weidig, of Joseph Fahys & Co., is in Philadelphia. Mr. Donnelly, of the Chicago office, maintained the good reputation of the house at the dinner.

That house party given by Benj. Allen & Co. was a house warmer in earnest. There were 17 in the party, but mere figures don't mean anything when B. C. Allen, Sam Dripps, John Cox, Jack Davidson, Fred Heffron and Chris Morgan are around.

J. F. Talbot was missed. He was detained in the east.

It seemed a little odd to find Mr. Cutter absent from the Elgin National Watch Co.'s group, but he was enjoying the comforts of a California trip.

The reception duties were ably performed by Mortimer N. Burchard, Herman F. Hahn, Julius Schnering, James B. Caldwell, Albert C. Becken, William J. Miller, Max Ellbogen, M. Loeb, R. C. Demarest and W. F. Juergens. It was the most attentive reception committee the jewelers have ever had.

There was a goodly representation of the city retailers, men who have made their mark in local jewelry affairs. Among these were J. R. Lilja, Fred Zeitz, J. Kirohberg, E. H. Goodrich, E. S. Hyman, H. S. Hyman, Morris Berg, A. W. Adcock, C. S. Hannan, Walter Peacock, Col. Keeler, C. E. Graves, Meyer H. Lebolt, J. S. Townsend, Thomas Davies, J. L. Rowe, H. D. Stevens.

The kind of out-of-town jewelers that attended the banquet is just the type of successful business men one likes to meet, and particularly to meet on such an occasion. It's like being among intimate friends to meet George E. Feagans, of Joliet, Ill.; J. W. Neasham, of Ottumwa, Ia.; W. H. Upmeyer, Milwaukee, Wis.; Thomas Juzek, Elgin, Ill.; Frank Le Bron, Keokuk, Ia.; Will H. Beck, Sioux City, Ia.; Andrew Rovelstad, Elgin, Ill.; J. C. Klaholt, Springfield, Ill.

C. H. Knights surprised many of his friends by returning from the Gulf coast in time to be at the banquet.

### Successful Annual Banquet of the Illinois Optical Society.

CHICAGO, Ill., Jan. 17.—The first annual banquet of the Illinois Optical Society was held last evening in the Palmer house. Preceding the banquet the regular quarterly business meeting was held in the rooms of the Chicago Jewelers' Association, in the afternoon. The afternoon session was devoted to routine business, and considerable time was given to discussion of matters of interest to the trade.

Nettie M. Juzek, of Elgin, read a paper on "Retinoscopy, the Most Valuable of Objective Tests." The paper showed much thought and careful preparation and the reader was liberally applauded. "Some Elementary Suggestions" was the subject of the address given by J. M. Johnston, of the J. M. & A. C. Johnston Optical Co.

The annual election of officers resulted as follows: President, Walter Wyatt, Peoria; first vice-president, J. M. Johnston, Chicago; second vice-president, O. C. Lamphear, Galesburg; third vice-president, H. A. Johnson, Monmouth; secretary, A. R. Chamberlin, Aurora; treasurer, W. C. Sommer, Chicago. Nearly 100 city and country opticians gathered around the fes-

tive board at the Palmer house in the evening. Hand's orchestra furnished music. The following toasts were given: "Greeting," President Wyatt; "Influence of Optical Societies," Prof. G. A. Rogers; "Our Guests," Henry Borsch; "The Twentieth Century Optician," J. M. Johnston; "The Universal Eye," Dr. Charles McCormick, and "Reminiscences," Dr. Geo. W. McFatrach, Franz Lorenz and N. Manasse.

Those who had the affair in charge and to whom great credit is due for its success, are: The banquet committee, W. C. Sommers, H. A. Johnson, C. H. Pixley and Loren L. Boyle; and the reception committee, Hugh MacLachlan, Robert Von der Hydt, E. S. Fowler, William Lambrecht, Burr Weaver, Otto Warning, E. E. Swadener and Walter Wyatt, chairman.

## The Best Class Of Your Trade

demands the best goods. The "Bell Special" is made for the finest class. It is the Best Gold-Filled Watch Case ever made. Contains more gold and is guaranteed for a longer time—35 years—than any other. You cannot appreciate this case until you see it—and the price is very low for the quality.



For any special monogram, engine-turned, add \$1.00 to price of plain polished case.

GET ALL THAT'S COMING TO YOU AND

BUY OF THE MAKER.

The Bell Watch Case Co.,  
CINCINNATI, OHIO.

**Death of Henry J. Cain.**

LANCASTER, Pa., Jan. 22.—Henry J. Cain, vice-president and general manager of the Hamilton Watch Co., died at his home, 435 W. Orange St., at 7 o'clock last evening. The deceased was stricken with apoplexy at his home on Dec. 19 last, and had been bed-fast the greater portion of the time from that date to the day of his death.

Henry J. Cain was born in Nashua, N. H., in 1841. He learned the balance portion of the trade of watchmaking in the factory in his native town, and when that concern was absorbed by the American Waltham Watch Co., and the plant moved to Waltham young Cain went with it. In the early 60's he went from Waltham to the United States factory at Marion, N. J., and the balance tools of this factory were built under his supervision. He, later, became foreman of the balance job.

From Marion he went with the New York Watch Co., Springfield, Mass., in 1867, and built the balance tools for the concern, again assuming the foremanship of the balance department. In 1876 he was made superintendent of the manufacturing department of the factory. In March, 1880, he was chosen superintendent of the Hampden Watch Co., then in Springfield, Mass., which position he held until 1890. At that time he came to this city, and under his supervision a number of the old Lancaster movements were completed. In September, 1890, he, with others, bought at auction the plant of the Aurora Watch Co., Aurora, Ill. He was made superintendent of this concern, which position he filled until he came to

this city in December, 1892, when he, with others, organized the Hamilton Watch Co., of which concern he was general manager to the time of his death. Upon the death of the late president of the concern, Capt. Franklin, which occurred some months since, the then vice-president of the concern, P. T. Watt, was elevated to the presidency and Mr. Cain was elected vice-president.

On Sept. 22, 1863, the deceased was married to Miss Chartina Wallace at Barnet, Vt., who, together with two daughters, Miss Leota Cain, of this city, and Dr. Maude Cain, of Boston, Mass., survive. To Mr. Cain greatly is due the credit for the excellence which the Hamilton movement has attained, as he was unquestionably one of the very best watchmakers in the country and a man whose executive ability was unsurpassed. His was an aggressive character, and he was a man of indomitable will, which prevented his demise at an earlier date. Since the beginning of Mr. Cain's fatal illness the Hamilton Watch factory has been operated under the superintendency of John C. Perry, who had been associated with the deceased in his different enterprises since 1869, and who is a thoroughly capable man. The body is to be taken to Springfield, Mass., on Tuesday for interment. The factory will be closed for some time.

The building occupied by Chapman & Jakeman, Main and Bank Sts., Norfolk, Va., is to be torn down about March 1, and on the site will be erected an entirely new building, which will be occupied by the same concern about Sept. 1.

**S. O. Bigney Begins Suit Against Other Manufacturers.**

PROVIDENCE, R. I., Jan. 22.—On Thursday, in the United States Court for this district, application was made and suit brought by Sidney O. Bigney, of S. O. Bigney & Co., Attleboro, against S. & B. Lederer Co. and Rodenberg & Dunn, of this city, for alleged infringement of the patent known as the "Bigney Vest Fob." Through his attorney, William R. Tillinghast, the plaintiff asks for an injunction against the defendants to restrain them from manufacturing the article protected by patent granted to him under date of Sept. 12, 1899, and also asks for damages and profits from the alleged manufacture of this patented article by the defendants up to this time.

The fob referred to consists of plated links, with a pendant charm. A light chain running from the swivel of the fob to the buttonhole bar guards the watch from being dropped.

**Jewelers' Gold Bars Withdrawn and Exchanged.**

*Week Ended Jan. 20, 1900.*

The U. S. Assay Office report:  
Gold bars exchanged for gold coin.... \$214,250.51  
Gold bars paid depositors..... 44,009.66

Total .....	\$258,260.17
Of this the gold bars exchanged for gold coin are reported as follows:	
Jan. 15.....	\$10,408
" 16.....	57,136
" 17.....	45,785
" 18.....	38,197
" 19.....	21,354
" 20.....	.....
Total .....	\$172,880

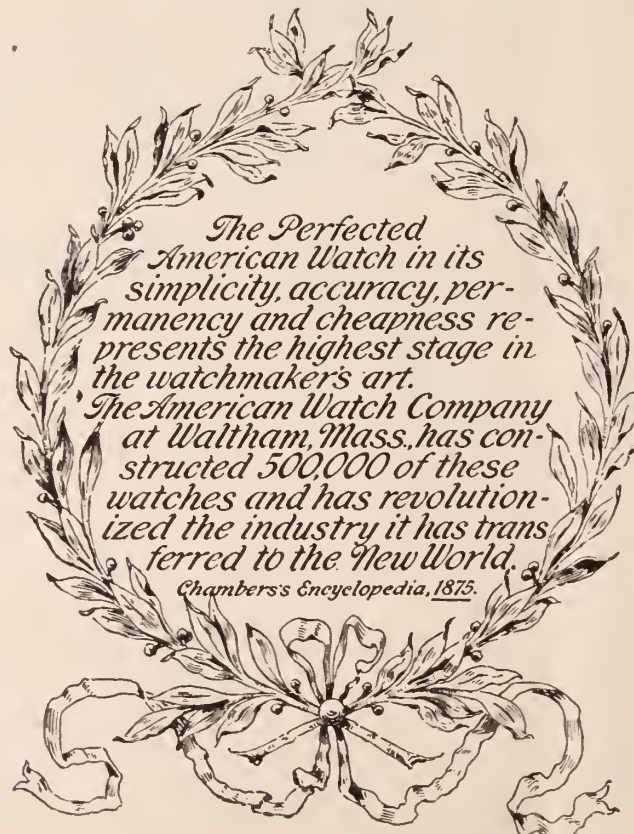



### Manufacturers Present a Strong Argument Against French Reciprocity Treaty.

ATTLEBORO, Mass., Jan. 22.—The members of the Jewelers' Tariff Committee, to whom the work of securing the retention of the present tariff on jewelry has been entrusted, have prepared a protest against a reduction of the duties on jewelry, as contemplated in the Reciprocity Treaty with France, copies of which have been forwarded to Senators Aldrich, Hoar, Lodge and Davis, and also to Congressmen Bull and Lovering. It says:

Whereas, A reciprocity treaty between the United States and France containing a provision for the reduction of 10 per cent on the present tariff on jewelry is to come before the United States Senate for action, the Jewelry Tariff Committee of the Attleboros and Providence respectfully ask your attention to the following statement regarding the condition of the people engaged in the jewelry business at Attleboro as an example of the general condition of the jewelry industry in New England from the year 1893 to the present time.

Practically the only industry in Attleboro is the manufacture of articles commonly known as jewelry, consequently the entire community is dependent upon this industry for their support and prosperity.

During the years 1893, 1894 and 1895, 65 per cent of jewelry labor was idle, and this condition entailed so great distress that on two occasions the town made an appropriation of money to be expended on highway work, voting that only citizens of Attleboro be employed.

Under this act the town of Attleboro gave employment to expert journeymen jewelers to perform with pick and shovel the work of common laborers at laborers' pay, as a necessary relief measure for the destitute citizens.

In 1896, during the agitation over the Dingley tariff law, the people engaged in the jewelry industry, realizing from experience the need of a protective tariff, presented a petition to Congress bearing the signatures of 67 manufacturers from the Attleboros and 134 from Providence, 1,405 wage earners from the Attleboros and 2,038 from Providence, requesting adequate protection from foreign made goods.

The enactment of the Dingley bill in 1897 granted the jewelers 60 per cent protection against 35 per cent under the Wilson bill.

Under this bill the jewelry industry has steadily improved. To-day there is no enforced idleness and labor is in demand.

The beneficial effect of the Dingley tariff is represented in the growth of the town in the past year. During the years 1893 to 1897 inclusive very little building was done. In 1899 from 75 to 90 dwelling houses were built without fully meeting the demand. Also in the past year three large jewelry factories were built having a floor space of 110,000 square feet.

As a result of our experience and after careful examination into the matter we believe that the existing rate of duty is for the best interests of all concerned.

Therefore, as affecting the prosperity of the jewelry industry, we earnestly appeal to you to do all in your power to eliminate the objectionable clause in the above mentioned treaty.

Very respectfully, FRANK W. WEAVER, Secretary, Committee.

SIDNEY O. BIGNEY,  
ALBERT A. BUSHEE,  
EVERETT S. HORTON,  
EDWARD A. SWEENEY,  
HENRY G. THRESHER,  
WILLIAM R. DUTEMPLE,  
HARRY P. KENT.

Replies have been received from two of the Senators as follows:

From Senator George F. Hoar, of the Judiciary Committee: "Dear Sir:—My attention has been called to the very important matter of the effect on the jewelry business if the French treaty shall go into effect. I shall do my best to secure a proper amendment, or if that cannot be had, a rejection of the treaty, unless some considerations which do not now occur to me should change my mind."

From Senator C. K. Davis, of the Committee on Foreign Relations: "I am in receipt of your esteemed favor of the 15th inst. with reference to certain provisions of the reciprocity treaty with France, and the same shall be laid before this committee for consideration."

# Experimental Acquaintance.

It's one thing to know about a man, but quite another thing to know him. There are over two thousand dealers who know us favorably as

## WATCH PEOPLE.

There are many more who know about us. We are quite willing to have the number of dealers who Really Do Know Us doubled. If **YOU** have never tried us, do so, and we'll promise to do our best, and Our Best is the **VERY BEST** anyone can do.

## Elgins—Walthams—Howards

C. G. ALFORD & Co.,

195 and 197 Broadway,

January 24, 1900.

NEW YORK, N. Y.

### Failure of the Wild Bros. Jewelry Company.

ST. LOUIS, Mo., Jan. 17.—Wild Bros. Jewelry Co. filed a chattel deed of trust on Monday afternoon, Jan. 15, to Peter A. Pickel, as trustee. The total amount of the indebtedness is placed at \$57,052.60 due to 79 creditors. Of the amount \$36,899.66 is due on notes, and the balance on open account. Among the amounts due on notes is \$5,725.05 to Mrs. Theresa Wild.

The largest among the other creditors are: F. F. Zimmerman, \$2,300; Hancock, Becker & Co., \$1,152; Hirsh & Hyman, \$1,940.07; Ingomar Goldsmith & Co., \$1,530.88; Leo Goldsmith, \$1,836.29; Fink, Bodenheimer & Co., \$2,218.37; I. W. Friedman, \$1,733.65; N. Guntzberger, \$1,791.87; Monroe Engelsman, \$1,933.24; R. A. Breidenbach, \$1,054.49; Otto Weber, \$1,125; Barney Zick, \$1,000; A. H. Bliss & Co., \$897.60; Geo. H. Cahoon & Co., \$787.90; C. P. Goldsmith & Co., \$664.41; David Marx, \$1,476.34; A. Lorsch & Co., \$1,560.37; M. A. Mead & Co., \$651.42; Smith & Crosby, \$910.84; American Watch Case Co., \$1,137.75; Wightman & Hough Co., \$452.67.

Wild Bros. Jewelry Co. had been in existence in St. Louis 27 years. Henry and Albert J. Wild composed the company. A. J. Wild, secretary of the company, was seen at his home, 1813 Iowa Ave. He expressed the belief that every creditor would be paid in full. "It is a fact," Mr. Wild said, "that my brother and I have been unable to get along together. My wife had advanced money at different times during the last year and a half, taking the notes of the firm for amounts varying from \$50 to \$1,500. There are 14 of these in all, I believe, and they have been involved in the differences of opinion between my brother and myself. Of course, I recognize the fact that he has been a very sick man for some time. I have no idea what the assets of the firm will amount to. We paid as long as we were able to, and there is little or nothing owing to St. Louis concerns."

Among the employes of the firm it had long been recognized that the two brothers could not get along together. Henry Wild, the president of the company, left for Eureka Springs, Ark., immediately after the failure. His friends say he should have gone there six months ago. Peter A. Pickel, named as trustee, began taking an inventory yesterday. This will require several days, and until it is completed Mr. Pickel says it will be impossible to tell how things stand. The firm have occupied the present building, at 104 N. 6th St., for seven years. On the lower floor they carried on a jobbing trade, while upstairs the manufacturing and repair departments were located. The firm employed several traveling salesmen, all of whom were called in immediately upon the failure.

### A PETITION TO DECLARE THE COMPANY BANKRUPT.

ST. LOUIS, Mo., Jan. 19.—A petition in involuntary bankruptcy was filed to-day in the United States District Court against Wild Bros. Jewelry Co. by the attorneys for the Jewelers' Association and Board of Trade, of New York, which organization

controls a large number of claims against the concern. It is contended that, in filing their deed of trust, recently, the Wild Bros. Jewelry Co. committed an act of bankruptcy within the meaning of the law.

### Petition of Bankruptcy Filed Against Sam Mayer.

DENVER, Col., Jan. 19.—A committee consisting of Sigmund Stern, of Stern Bros. & Co., and Mr. Jacobson, of Jacobson Bros., New York, representing the eastern creditors of Sam Mayer, have been in this city the past week, making an investigation of the condition of Mr. Mayer's assets and liabilities. A petition in involuntary bankruptcy was filed against Mr. Mayer to-day on behalf of the eastern creditors represented by the Jewelers' Association and Board of Trade, of New York, and a hearing on this petition will be given Monday, when it is expected that a decision adjudicating Mayer bankrupt will be handed down by the Court.

It is reported that the creditors and the debtor have come to an arrangement by which, after Mayer goes into bankruptcy, a compromise will be effected on a basis of 40 per cent.

### George C. Edwards, of the International Silver Co., Buys Out Hall-Elton Co.

WALLINGFORD, Conn., Jan. 20.—The controlling interest in the Hall-Elton Co., which has been owned for many years to the amount of \$63,000 by Benedict & Burnham Mfg. Co., Waterbury, has been sold to George C. Edwards, of Bridgeport, one of the officers in the International Silver Co. The capital stock of the company is \$125,000. The stock which Mr. Edwards purchased will not be transferred to him until the annual meeting of the Hall-Elton Co., held Jan. 25.

Whether Mr. Edwards is to retain the stock personally or turn it over to the International Silver Co. later on is not known. For 10 years the Meriden Britannia Co. leased the factory of the Hall-Elton Co., and paid for the lease 10 per cent a year on the capital stock, and after the 10 years expired they have been paying about five per cent on the capital stock for the lease. In the lease it was stipulated that if it was to be discontinued for the next year, notice should be given by the first of October preceding the expiration of the year's lease. No notice was given last year of a discontinuance, and so the lease held good for this year. Mr. Edwards will probably be elected president of the Hall-Elton Co.

President Dodd, of the I. S. Co., said this afternoon that the reported purchase of the Hall-Elton stock was not made by Mr. Edwards for the International Silver Co., and so far as that company was concerned, the purchase was a private one.

Dechert & Co., Paterson, N. J., have organized their business into a stock company and articles were filed Jan. 18 with the County Clerk. The capital is \$20,000, in 200 shares of \$100 each. The stockholders are Julius Dechert, 53 shares; William D. Gray, 25, and Gustav Hausermann, 23. The company will continue business at the old stand.

### Meyer Goldstein at Length in the Hands of the Law.

Meyer Goldstein, a former bookkeeper for H. S. Kramer, 82 Nassau St., New York, was arraigned in the Centre St. Police Court, Saturday, for examination on several charges of larceny. As THE CIRCULAR has mentioned several times, Goldstein is accused by his former employer of purchasing a large quantity of diamonds in Kramer's name without authority, and is also accused of forging Kramer's name to checks in payment of these goods. All these acts were committed prior to Nov. 1 last, but Goldstein skipped out about that time and he was not apprehended until Jan. 16. A Central Office detective who had been shadowing Goldstein's brother, followed the latter to Sixth Ave. and 4th St., where he met the prisoner and handed him a small valise. The detective stepped up and arrested Goldstein and took him before Magistrate Crane. It is said that the prisoner when arrested was about to take passage on a vessel to New Orleans.

The specific charge against Goldstein is that he gave B. H. Davis & Co., 68 Nassau St., a forged check for \$212 in payment for diamonds he had ordered in Kramer's name. The check was drawn on the Seventh National bank and purported to be signed by Kramer. After this charge had been received a representative of B. H. Davis & Co., accompanied by representatives of Chester Billings & Son, Oppenheimer Bros. & Veith, Sig. Hirschberg, Eichberg & Co. and Rosenbaum & Adler, appeared before the magistrate to charge Goldstein with having victimized them out of from \$500 to \$2,000 worth of goods each. Mr. Davis entered a charge of larceny of eight unmounted diamonds, valued at \$620, got in August last. Goldstein was held in \$2,000 bail on each charge for examination Saturday. On Saturday Abraham Levy, counsel for Goldstein, waived examination and the prisoner was committed to await the action of the Grand Jury in \$4,000 bail.

### Express Case of Interest to Jewelers.

PROVIDENCE, R. I., Jan. 22.—Richard Bacon, manufacturing jeweler, recovered a jewelry case that was being held by an agent in New York on account of a disputed bill for commissions, in a rather unusual way. A brother of Mr. Bacon wrote to the New York agent, requesting him to send the case to Providence, C. O. D., by Adams Express Co. The case was forwarded, accompanied by a bill for \$21.47, and Mr. Bacon then went to the express office on Weybosset St. and demanded the package, but refused to pay the bill for \$21.47.

The express company declined to give up the case, and Mr. Bacon replevied the property. At the hearing before Judge Sweetland the defense claimed that the letter written by Mr. Bacon's brother was a recognition that the New Yorker had a right of property in the package, but the Court gave decision for the plaintiff for possession. Mr. Bacon recovered his jewelry case, and the balance on the bill is unpaid.

## BUYERS' INFORMATION BUREAU.

Questions as to the makers of certain lines of goods, where to buy certain lines, where certain kinds of work are done, the owners of certain trade-marks and other matters relating to the buying branch of a jewelry business will be cheerfully answered under this department. The reader cannot ask too many questions.

BRADFORD, Pa., Jan. 9, 1900.

Editor of THE JEWELERS' CIRCULAR:

Will you please answer the two questions below through your Buyers' Information Bureau: 1st. Where can I find high grade, plain, thin, blown glass ware, such as wine, water, champagne glasses; also bitters bottles, wine decanters, of a very fine quality, highly polished, best can be produced? Do not want anything of common goods. I have seen such goods at Sherry's and Delmonico's, but cannot find anything but ordinary goods. 2d. Where can I buy at wholesale Macmonnie's bronzes? By answering the above as soon as possible you will oblige,

Yours very truly,

P. L. LOWENTHAL.

ANSWER:—The following firms can supply the sort of glass ware correspondent wants: Compagnie des Cristalleries de Baccarat, 41 Warren St.; Fensterer & Ruhe 47 Murray St.; L. Straus & Sons, 42-46 Warren St.; Bawo & Dotter, 28 Barclay St., New York. 2. Macmonnie's bronzes are not in the market in wholesale quantities. Theo. B. Starr, 206 Fifth Ave., New York, has exclusive control in this country of such of this sculptor's bronzes as are for sale. Mr. Starr will sell to responsible parties, at small discount, and will send, upon application, photograph of any particular bronze requested.

LINCOLN, Ill., Jan. 15, 1900.

Editor of THE JEWELERS' CIRCULAR:

Will you please send me the address of factories that make a line of gold and silver locating needles, and can you tell me if you can depend upon them for locating gold and silver? I know you can tell me, as all the information I have wanted THE JEWELERS' CIRCULAR has always found for me. Wishing you success, I am,

Yours truly,

A. J. REINHARDT.

ANSWER:—The largest manufacturers of prospectors' instruments in this country say that the only locating needles made are those for locating iron and other metals possessing magnetic qualities; there are none for gold and silver.

DOVER, N. H., Jan. 10, 1900.

Editor of THE JEWELERS' CIRCULAR:

Will you kindly give us the address of a few first-class umbrella manufacturers or jobbers in New York city or Philadelphia who make and sell to dealers umbrella covers ready to put on? If you can accommodate us will esteem it a favor.

Yours very truly,

HODSDON BROS.

ANSWER:—Follmer, Clogg & Co., 414 Broadway, New York, will sell umbrella covers ready to put on; in fact, they sell all parts of umbrellas, sticks, ribs, etc., in any quantity. White & Major, 25 Union Square, can also furnish such goods.

LIMA, O., Jan. 4, 1900.

Editor of THE JEWELERS' CIRCULAR:

Will you kindly give us the address of firms doing portrait work on ivory?

Respectfully,

MACDONALD & Co.

ANSWER:—We recommend Leon Favre, 124 W. 34th St., New York, to do this work.

BATH, N. Y., Jan. 8, 1900.

Editor of THE JEWELERS' CIRCULAR:

Would you be so kind as to give me the address of the Brooklyn Watch Case Co.? If you can, you will oblige me very much.

Yours respectfully,

CHAS. KAUSCH.

ANSWER:—Brooklyn Watch Case Co., 54 Maiden Lane, New York.

LAFAYETTE, Ind., Jan. 12, 1900.

Editor of THE JEWELERS' CIRCULAR:

Can you tell us the successor of the Ladd Watch Case Co., or are they out of business altogether? Kindly let us hear from you as soon as possible, and oblige yours truly,

C. H. ANKENY.

ANSWER:—The Ladd Watch Case Co. are out of business and have no successors.

MARTINSBURG, W. Va., Jan. 13, 1900.

Editor of THE JEWELERS' CIRCULAR:

Will you please send us the address of parties who put pictures on watch cases?

Yours very truly,

W. L. JONES.

ANSWER:—Leon Favre, 124 W. 34th St., New York, does this work.

MILWAUKEE, Wis., Jan. 11, 1900.

Editor of THE JEWELERS' CIRCULAR:

Will you please advise us where the American Screw Company are located? Thanking you in advance for same, we remain respectfully yours,

J. MEDNIKOW JEWELERS' SUPPLY CO.

Per C. J. N.

ANSWER:—The address of this company is Providence, R. I.

### Utica, N. Y.

Thomas McGovern, of this city, has gone with the Oneida Silver Ware Co. as traveling salesman.

The recent fire at J. B. Wells, Son & Co. caused a loss of \$100,000. The firm carried a large line of jewelry, etc.

It is reported that the Oneida Silver Ware Co., Oneida, are anxious to locate in this city. Some of the stockholders are residents of this city, and they think Utica offers many advantages over their present location. The matter will be brought to the attention of the Chamber of Commerce. The company employ about 70 mechanics.

### Birmingham, Ala.

Dr. Geo. M. Gill, optician, is with the C. N. Maxwell Jewelry Co., Tuskaalooza, for a while.

Drennen & Co., when they occupy their handsome new brick 5-story store about March 1, will put in a stock of jewelry. William Rosenstihl, late member of Rosenstihl Bros. and secretary of the Alabama Retail Jewelers' Association, it is understood, will be in charge.

James H. Tattersall, jeweler, Gloucester, Mass., has moved into the newly finished basement apartment in the First National Bank building.

A. J. Tulian, who has been manager of the jewelry of Geo. R. Strickland & Co., at New London, Wis., has resumed his old position with A. H. Marwede, Alpena, Mich.

## A Great Jewelers' Banquet.

The First Annual Banquet of the Jewelers' Association and Board of Trade a Success in Every Respect.

The first annual banquet of the Jewelers' Association and Board of Trade was held last night in the ballroom of the Waldorf-Astoria Hotel, 33d-34th Sts. and Fifth Ave., New York, and verified all predictions as to its success and greatness. The banquet was attended by about 500 people altogether—members, guests and speakers—which was the largest number that could possibly be put into the room in which it was held. President Augustus K. Sloan and 10 of the Association's guests and speakers sat at the head table, and at right angles in front of them were the other members of the Association and their guests, who sat at 10 long tables accommodating 47 or 48 plates each.

At the right hand of President Sloan sat Lieut.-Gov. Timothy L. Woodruff, and on his left the Hon. Dean C. Worcester, a member of the United States Commission to the Philippine Islands. Next to Lieut.-Gov. Woodruff was the Hon. John S. Wise, then J. Warner Hutchins, president of the Philadelphia Jewelers' Club, Dutec Wilcox, president of the Manufacturing Jewelers' Board of Trade, Providence, and at the right hand Frank L. Crawford, the attorney for the Association. Next to Mr. Worcester sat Wm. H. McElroy, of the New York Mail and Express; John R. Van Wormer and Rev. Dr. Geo. E. Strobbridge. At the left hand Hon. Geo. R. Bidwell, Collector of the Port of New York.

After the dinner had been thoroughly enjoyed and cigars were lighted, the usual preliminaries were gone through with, and then President Sloan introduced Mr. Worcester as the first speaker of the evening. He responded to the toast, "Our Newest Possessions," and was followed by Lieut.-Gov. Woodruff to the toast, "The America of To-day." The other toasts were responded to as follows: "The Gold Standard," Hon. John S. Wise; "The Press," Wm. H. McElroy; "Some Aspects of Trade," John R. Van Wormer, and "My Country, 'Tis of Thee," Rev. Dr. G. E. Strobbridge.

A detailed account of this banquet with a full report of the addresses will appear in the "Consolidation Number" of this journal, Jan. 31.

N. J. Battershell's jewelry store, Bloomington, Ill., was burned out Jan. 16.

A petition in bankruptcy has been filed against D. Urwitz, Wilkes-Barre, Pa.

S. Bachrach, Richmond, Va., has given a trust deed for \$2,000 to C. L. Duncan.

A fire in Wadena, Minn., last week burned out J. R. Anderson's jewelry store.

George Pugh, for many years a jeweler at 345 Superior St., Cleveland, O., died Jan. 13.

A man was captured last week trying to set fire to Redwine's jewelry store, Henderson, Tex.

George Vansicle, Thornton, Tex., committed suicide on Jan. 14 by shooting himself in the region of the heart with a 32-caliber pistol.

# TO RETAIL JEWELERS, WARNING

## Keep Tabs on the Tags and Swivels.

When you buy Blackinton Chains the stamps on swivels tell the story.

EACH TAG AND STAMP ON SWIVEL REPRESENTS A DIFFERENT QUALITY.

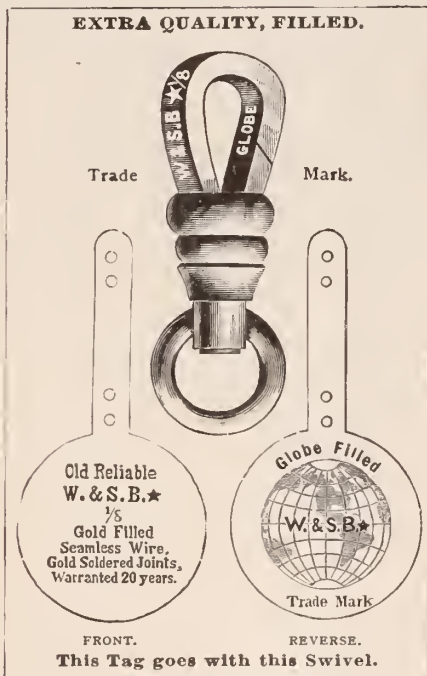

OLD RELIABLE  
**W. & S. B. ★ GLOBE FILLED**  
 ARE EXTRA QUALITY  
 AND WARRANTED TO ASSAY  $\frac{1}{8}$  GOLD.

OUR REGULAR  
**OLD RELIABLE W. & S. B. ★**  
 ARE  $\frac{1}{10}$  PLATE AND SUCH AS WE  
 HAVE MADE FOR 30 YEARS.

IF YOUR SWIVELS BEAR EITHER OF THE ABOVE TWO STAMPS YOU ARE SURE OF GETTING CHAINS THAT EXCEL IN

### QUALITY, DESIGN AND FINISH,

THE GREATEST OF VIRTUES THAT COMBINE TO MAKE A LINE OF GOODS

### RELIABLE AND SALABLE.

EVERY JOBBER CARRIES THESE CHAINS. INSIST ON SEEING THEM; A CAREFUL EXAMINATION WILL PROVE THE ABOVE.

Fac



MR. W. SUMNER BLACKINTON EXPLAINING THE DIFFERENT QUALITIES AS INDICATED BY THE STAMP ON THE TAGS AND ON THE GOODS.

QUALITY.



Mark.

Reliable.  
& S.B.★  
Seamless Wire.

with this Swivel.



**Each Article of this Grade  
is Stamped as above.**

**THIS IS OUR 2d QUALITY.**

**CAUTION**

Retailers when buying should be most careful to see that chains so stamped are not sold as either the old reliable W. & S. B. ★ GLOBE FILLED or the old reliable W. & S. B. ★. THIS IS BEING DONE AND HAS BEEN DONE EXTENSIVELY.

SECOND QUALITY.

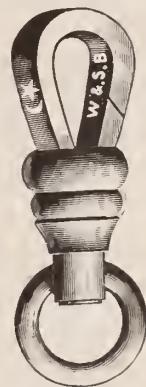

Trade

Mark.

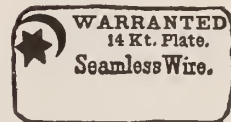

This Tag goes with this Swivel.

**W. & S. BLACKINTON.**

Providence, R. I.

New York, 14 Maiden Lane.

# A Few Suggestions.

**Do you want** your stock of Sterling Silver Ware to embrace the identical articles that are sold by Dry Goods Stores? Having in mind that the latter are sending catalogues by the thousands to the homes of your own customers, is it not a fact that the illustration of the patterns in your stock in such Catalogues makes these goods undesirable for the finer class of your patrons? Is it not true that a person of taste, desiring to make a Wedding Anniversary or other complimentary gift, would hesitate to send an article generally found in Dry Goods and Department Store Catalogues?

**If these are facts**, why not confine your purchases of Silver to the Manufacturers who deal only with the legitimate Jewelry trade, thus protecting your interests and preserving the fashionable exclusiveness of the wares in your stock, so often a feature in consummating an important sale? The productions of the **Gorham Mfg. Co.** are never sold except through the best class of Jewelers.

**They are fashionable.**

**They are exclusive.**

**Their quality is unquestioned.**

**They are not higher priced.**



## Gorham Mfg. Co.,

...SILVERSMITHS...

Broadway and  
19th Street,  New York City.

BRANCHES:

NEW YORK:  
21 & 23 Maiden Lane.

CHICAGO:  
131-137 Wabash Avenue.

SAN FRANCISCO:  
118-120 Sutter Street.

WORKS: PROVIDENCE, R. I., AND NEW YORK CITY.

# The Jewelers' Circular AND HOROLOGICAL REVIEW.

PUBLISHED EVERY WEDNESDAY BY  
**THE JEWELERS' CIRCULAR PUB'G CO.,**  
CORBIN BUILDING, 11 JOHN ST., COR. BROADWAY,  
NEW YORK.

TELEPHONE: 1148 CORTLANDT. CABLE ADDRESS: JEWLAR, NEW YORK.

A JOURNAL DEVOTED TO THE INTERESTS OF JEWELERS,  
WATCHMAKERS, SILVERSMITHS, ELECTRO-PLATE MANU-  
FACTURERS, AND ALL ENGAGED IN KINDRED BRANCHES OF  
INDUSTRY.

Member of the American Trade Press Association

Our editorial columns will contain our own opinions only, and we shall present in other columns only what we consider of interest or value to our readers. Advertising matter will not be printed as news.

Advertising rates in THE CIRCULAR are lower, considering the number of tradesmen reached by its large circulation, than in any other jewelry journal.

Notices of changes in standing advertisements must be received one week in advance; new matter can be received up to Monday.

## INFORMATION FOR SUBSCRIBERS.

### Terms of Subscription, Postage Prepaid.

	PER ANNUM.
United States and Canada, - - -	\$2.00
Foreign Countries in Postal Union, - - -	4.00
Single Copies, - - - - -	.10

New Subscribers can commence at any time.

Payments for THE CIRCULAR, when sent by mail, should be made in a Post-Office Money Order, Bank Check or Draft, or an Express Money Order or Registered Letter. All postmasters are required to register letters whenever requested to do so.

Pay money only to authorized collectors having proper credentials.

**Returning Copies.** Returning your paper will not enable us to discontinue it, as we cannot find your name on our books unless your address is given.

**Changing Address.** In changing address always give the old as well as the new one. Your name cannot be found on our books unless this is done.

**Discontinuances.** We will continue to send papers until there is a specific order to stop, in connection with which all arrearages must be paid; but such an order can be given at any time, to take effect at or after the expiration of the subscription. All such orders will be promptly acknowledged by mail.

**Liability.** The courts have decided that all subscribers to journals are responsible until arrearages are paid in full and an order to discontinue has been received by the publisher.

### THE JEWELERS' CIRCULAR IN EUROPE.

Among the places in Europe where THE JEWELERS' CIRCULAR is on file are the following:

**LONDON**—First Ave. Hotel, Holborn, E. C.; Holborn Viaduct Hotel, Royal Hotel.  
**PARIS**—Hotel de L'Athene, Rue Scribe.  
**LEIPZIG**—Handels-Zeitung, für die gesamte Uhren Industrie.  
**BERLIN**—Deutsche Uhrmacher Zeitung, Jager-Strasse, 73.  
**GENEVA**—Journal Suisse D'Horlogerie.  
**AMSTERDAM**—Continental Club, Hotel Amstel.  
**ANTWERP**—Diamond Club, Rue de Pelican.

Vol. XXXIX. Jan. 24, 1900. No. 26.

Every line of reading matter in THE JEWELERS' CIRCULAR, with the exception of the few brief extracts from exchanges, always properly credited, is written exclusively for this journal. Each issue of THE JEWELERS' CIRCULAR is copyrighted. Permission to quote is extended to other publications provided such quotations are properly credited.

# CONSOLIDATION NUMBER.

## THE NEXT ISSUE

being the first consolidated number of THE JEWELERS' CIRCULAR and THE JEWELERS' WEEKLY, will be an edition of unusual interest, containing among other features a full report, artistically arranged, of the Banquet of

## THE JEWELERS' ASSOCIATION AND BOARD OF TRADE.

Copy for advertising in this issue should be in this office at the earliest possible moment, to insure insertion and good display.

"Mistakes Happen **A**MONG the many letters to the editor of THE CIRCULAR, received during the past week, were three which took issue with the statements contained in two news items. These letters are reproduced almost verbatim on a following page, no endeavor being made to disguise or hide THE CIRCULAR's shortcomings in its news service, as far as these two items are concerned. The extreme rarity of such occurrences lends assurance to this journal to acknowledge the corn when such errors are committed. In reflecting the state of trade in various localities, greater delicacy of expression is demanded than the casual observer would infer, if the report is to have any weight with the reader. The ease with which the reporter can sweepingly assert that business is booming and the tendency of the editor to put the most optimistic tone in such reports, are calculated to produce reviews of trade of such a perpetual sameness as to be of flabby effect if they produce any effect whatsoever. THE CIRCULAR, recognizing that such reviews, if authentic, are of vital interest to the trade, has endeavored to report the truth as near as fathomable, avoiding sullen pessimism as well as extravagant optimism, though being only too glad to look on the bright side of things. It thus occurred, that, in a review of the Christmas trade on the Pacific Coast, it was announced that the volume of business in Los Angeles did not quite come up to anticipations. This qualified assertion called forth a condemnatory letter from one of THE CIRCULAR's oldest and best subscribers; and while his statements are most convincing, and while this journal regrets the misinformation conveyed by its correspondent, yet it is gratified to learn that the jewelers of Los Angeles were really especially favored during the holiday season. THE CIRCULAR would rather learn that the trade, or any section of it, has been prosperous than that an item of its news, asserting something to the contrary, was correct. Somewhat the same remarks may be made as to the item regarding C. F. Willemijn. THE CIRCULAR is most happy to learn that this gentleman is not dead. His prolonged illness had undoubtedly given rise to the impression, in some quarters, that he had passed away. It was a sad variation of the old story of the three black crows, but it must have been sincerely believed by persons who knew Mr. Willemijn well, for the report was carried at least as far as Chi-

ago, whence it was remitted to THE CIRCULAR. That this gentleman will speedily recover from his illness is the earnest wish of his many friends, among whom he may consider THE JEWELERS' CIRCULAR.

## Give the Act a Fair Trial.

**W**HILE the operation of the national bankruptcy law has brought out features, enumerated in a resolution of the New York Credit Men's Association, that are susceptible of improvement, any movement for absolute repeal of the act is at least premature if not unwarranted. The bankruptcy act is not an ideal measure; it was the result of compromise, and no compromise can please everybody. But an immense amount of labor was expended on it, and very few bills passed by Congress are so carefully drawn as this one was. Now, however, comes Mr. De Armond, of Missouri, a Congressman of considerable influence, with a bill that contemplates the demolition of the whole structure almost as soon as it is completed. This attempt, we repeat, is, from every point of view, premature. More time is necessary both to disclose the merits and to draw forth the frailties of the act. While it is true that the previous bankruptcy acts have not been enduring measures, yet a vast amount of indebtedness was cleared away under them before they were repealed. The present act is far superior to its predecessors, and there is reason to believe it will not be repealed without a fair trial, which it has not yet had.

"Practically the only industry in Attleboro is the manufacture of articles commonly known as jewelry; consequently the entire community is dependent on this industry for their support and prosperity. The beneficial effect of the Dingley tariff is represented in the growth of the town in the past year. Therefore, as affecting the prosperity of the jewelry industry, we earnestly appeal to you to do all in your power to eliminate the objectionable clause in the above-mentioned treaty." [From the petition of the eastern jewelry manufacturers to the New England members of Congress urging these legislators to use their influence to prevent the ratification of the reciprocity treaty with France.]

**T**HIS argument might be expanded *ad infinitum*, but its force could not be strengthened. If the petition of these manufacturing jewelers should prove unsuccessful, what would become of the virtue claimed to exist in the principle of protection?

## LETTERS TO THE EDITOR.

## LOS ANGELES JEWELERS CONDEMN A "CIRCULAR" ITEM.

LOS ANGELES, Cal., Jan. 13, 1900.

Editor of THE JEWELERS' CIRCULAR:

Allow us to call your attention to an injustice you unknowingly have done the jewelers of Los Angeles by the misstatement you have allowed your San Francisco correspondent to place in your columns. In the issue of Jan. 3 on page 36 this item appears:

## THE HOLIDAY TRADE.

Christmas is passed and wholesalers and retailers alike are taking a little rest. It is the general verdict that the holiday season just passed has been one of the best in the history of the city. It began early and increased steadily clear up till Christmas Day. In the State at large the same condition seems to have prevailed. Only in one spot—the extreme south—has there been any disappointment. The jobbers did a good business in Los Angeles and San Diego early in the season, but the hopes of the retail trade there do not seem to have been realized.

As far as you refer to the city of Los Angeles you make a mistake. It has no foundation in fact or even a grain of truth. There are over 30 jewelry stores in Los Angeles, as the sale of that class of goods has for a long, long time been expanding every day. The people want good goods at fair prices. Los Angeles is a cash town; credits are few and only exceptional; cash prevails. No one store monopolized the trade; every store was fully rewarded with trade according as it was ready for it, and not only in the jewelry business but in every line of trade was this the case.

We are positive of the truth of these statements and have much pleasure in making this correction known to you.

We have made a close inquiry in reliable and satisfactory sources and we affirm now that there is not one single jewelry storekeeper in this city, according to his stock, his preparations made for the holiday trade and the energy and ability thrown into his business, who is not able to say he is satisfied with his trade. It is certain that those who went after trade enjoyed the largest cash trade they ever did in our city, not for a few days only but for every day in the month of December. Trade commenced early in the month—indeed, in the last days of November—and got better and better every day until Xmas. We enjoy two Christmas trades in Los Angeles: Purchases for eastern friends must be made and started off before the 15th of the month to get there on time. Then our local trade warms up.

Personally with us there never was such a December trade in all our 18 Xmas trade experiences in Los Angeles. Everyone had money, everyone wanted to spend it. The demand was for good goods in every line. There was no complaint about high price goods; the goods sold on their merits in immense quantities. Low priced novelties were not so popular. But that is no complaint.

We allow you to use this letter and these statements in any way you wish to counteract the misstatement your correspondent has placed in your mouth to the gross

injustice of every jeweler in Los Angeles city. Your paper has always been modest, honest and fair, and you cannot allow any correspondent to put so many respectable men in the position your item as referred to above places us.

Yours respectfully,  
MONTGOMERY BROS.

## THE ITEM REGARDING C. F. WILLEMIN.

NORTH ATTLEBORO, Mass., Jan. 19, 1900.

Editor of THE JEWELERS' CIRCULAR:

We are very much surprised to find you announce the death of Mr. C. F. Willemin in your issue of Jan. 17. This statement is erroneous. It is true he has been ill for a long time, but is on the road to recovery we should judge. Mr. Frothingham saw him this week and considers his condition improved, and that he is in the convalescent rank at present. Better correct your statement. Yours respectfully,

T. G. FROTHINGHAM &amp; Co.

BROOKLYN, N. Y., Jan. 21, 1900.

Editor of THE JEWELERS' CIRCULAR:

In your issue of Wednesday, the 17th, which has just reached me, I notice an obituary on your humble servant. In your next issue will you kindly correct same. Happy to say I am now convalescing rapidly and expect to be among the trade again early this coming month. By giving this your immediate attention, you will greatly oblige, Yours respectfully,

CHAS. F. WILLEMIN,  
late with T. G. Frothingham & Co.

## Trans-Atlantic Voyagers.

## TO EUROPE.

Edward Holbrook, of the Gorham Mfg. Co., New York; A. J. Grinberg, New York, and Louis Witsenhausen, New York, accompanied by his bride, sailed Wednesday on the *St. Paul*.

## FROM EUROPE.

L. Tannenbaum, of L. Tannenbaum & Co., New York, returned last week on the *Campania*.

M. J. Lasar, New York, arrived last week on the *Friesland*.

Paul Fleischer, New York; E. J. Ovington, of Ovington Bros., New York, and F. J. Pointon, of Minton's, Ltd., England, arrived last week on the *Oceanic*.

## Death of Prof. Thomas Egleston.

Prof. Thomas Egleston, LL.D., the founder of the School of Mines of Columbia University, who died Jan. 15 at his home, 35 Washington Sq., New York, was well known as a mineralogist and gem expert. The deceased was professor of mineralogy and metallurgy in the School of Mines, and was 69 years old. He was born in New York and received his education at Yale, after which he went to Europe to pursue his studies in geology, chemistry and metallurgy. After his return to this country, in 1861, he was director of the mineralogical section of the Smithsonian Institute, Washington, and later founded the School of Mines at Columbia. He was one of the founders of the American Institute of Mining Engineers and was at one time its president. Prof. Egleston was prominent in a host of other scientific organizations and held many positions of honor under the Government.

## ON MEMORANDUM

After the Holiday Clean-out



Your cases need filling up. We will send you on approval anything you want in Diamonds and Diamond Jewelry to fill up. There's no question that prices will go still higher, so you'll be the gainer if you let us know at once just what you need.

V. WARRING, N. Y.

## CROSS &amp; BEGUELIN

Importers and Cutters of Diamonds and Precious Stones

43 Rue de Meslay, PARIS

Telephone,  
2188 Cortlandt

17 Maiden Lane, NEW YORK



**New York Notes.**

I. L. Friedman is now with Laubheim Bros., 65 Nassau St.

H. Bruml has entered a judgment for \$68.82 against Solomon Robinson.

Bessie Larkin has entered a judgment for costs amounting to \$103.96 against Emilie S. de Hierapolis and R. E. Carpenter.

The Crescent Jewelry Co., 721-723 Broadway, will move about Feb. 1 to larger and more commodious quarters at 418 Clermont Ave., Brooklyn.

Saul Prager, a former jeweler, who filed a petition in bankruptcy some time ago, was discharged of all his debts by Judge Brown, of the United States District Court, Wednesday.

The Jewelers' & Tradesmen's Co. have decided to change their name to the Tradesmen's Life Insurance Co., and application for permission to make this change will be made March 5 at 10 o'clock A. M. to the New York Supreme Court.

William Traitel, who died Saturday at his home, 175 W. 81st St., was for many years in the diamond business in New York. Mr. Traitel was born in Germany 75 years ago, and came to New York city about 50 years ago. An attack of paralysis four months ago was the cause of his death. He leaves a wife and nine children.

Irving L. Russell, a former jeweler of 18 John St., who some time ago filed a petition in bankruptcy, has made application to the United States District Court

for a discharge of all his debts. A hearing on this petition will be held before Judge Brown, of the United States District Court, on Jan. 31 at 10 o'clock A. M. The creditors are notified to show cause why the discharge asked for should not be granted.

In the Yorkville Police Court Wednesday, John Abrahams, an Irishman, was accused of breaking a glass case of Max Waderker, jeweler, 1260 Second Ave. Abrahams admitted breaking it, but claimed that he had lost his job through a defective alarm clock sold to him by the jeweler, and in expostulating with the latter he unconsciously brought his fist down on the case. The matter, he said, was an accident, but it nevertheless cost him a \$2 fine.

The Broadway Athletic Club has authorized the purchase of an electric clock, which will at once be put into use. The clock will be square in shape, and the minutes and seconds will be distinctly printed so as to be visible from any part of the building. The clock will be suspended above the ring, and the timekeeper will be the only one allowed to control it. He will regulate the piece with the aid of an automatic button, which will be attached to the clock by a wire.

Through the arrest of Isaac Reppenport, last week, it became known that Louis Shapiro was the man from whom jewelry to the amount of about \$3,000 was stolen on Dec. 23 last. Shapiro, who is a diamond broker, with an office at 47 Mai-

den Lane, lost the goods while asleep in a trolley car. Reppenport was arrested by detectives while attempting to pawn mountings which were identified by Shapiro as having been part of the jewelry stolen from him. Reppenport was held in \$3,000 bail for examination, but a CIRCULAR reporter was informed Monday, at the office of Shapiro, that he had recovered his property and the prisoner had been released from custody.

The contest over the will of the late Robt. Wilson, a former journeyman jeweler of Brooklyn, mentioned in the last issue of THE CIRCULAR, was continued last week before Surrogate Abbott, of Brooklyn. The deceased left about \$80,000, in which his two sisters and his brother, John, come in for equal shares. John, however, finding that his share was left in trust, contested the probate of the will. According to the story told before Surrogate Abbott, the money was accumulated through the savings of the entire family, consisting originally of two brothers and three sisters, who lived together co-operatively until July, 1898, when Robert, the senior brother and banker, died and left the will disposing of the property. In describing how the family fund was accumulated, the surviving members testified that the household expenses of the family did not average over \$4 a week.

The Commercial Travelers' Club, of Mt. Vernon, was recently formed in that city, under very favorable auspices, and the success of the organization seems to be al-

**C. DORFLINGER & SONS.**

Samples of our new lines for **1900** can now be seen.

36 Murray Street,

NEW YORK.

1851.

1900.

**THE CHATHAM NATIONAL BANK, NEW YORK.**

CAPITAL STOCK, - - - - \$450,000  
 UNDIVIDED PROFITS, - . . . 974,518

GEO. M. HARD, President.

H. P. DOREMUS, Cashier.

W. H. STRAWN, Ass't Cashier.

ready assured. The club was formally organized Dec. 30, and is intended to promote the social and moral welfare of the traveling men living in Mt. Vernon. A number of representatives of jewelry, watch, clock and silver houses have already been enrolled among the members, and two of them are prominent as officers. These are the president, Benj. Westervelt, with the New England Watch Co.; and chairman of the board of governors, A. Eastwick Wood, with J. B. & S. M. Knowles Co. The club's headquarters, which have already been comfortably fitted up, are in rooms 1 and 2, Ferguson building. The address of the secretary and treasurer is Mr. Kronfeldt, P. O. box 57, Mt. Vernon.

Jos. H. Fink, of J. H. Fink & Co., has gone south and will spend the Winter at Southern Pines, N. C.

J. J. Cohn, manufacturer of leather goods, 35 Maiden Lane, has rented an additional loft as a stock room.

An order of discontinuance of the libel suit brought by Wm. Reiman against Jacob Dreicer, some time ago, has been signed.

Stern Bros. & Co., diamond cutters, 68 Nassau St., received last Monday one of the largest shipments of rough diamonds that has come to this country in several months.

S. Wolff will leave New York this week for the Middle States and the west in the interest of Eisler & Laubheim, manufacturers of diamond mountings, 87 Maiden Lane.

The action of Margaret Willison against the Jewelers' and Tradesmen's Co. has been set down for a second trial, Jan. 26, in the City Court. As already told in THE CIRCULAR, the suit was brought by the plaintiff as a beneficiary of a life insurance policy, was tried Dec. 20, 1898, and a verdict for \$652 rendered in the plaintiff's favor. The General Term of the City Court recently reversed this verdict and sent the case back for a re-trial.

Justice Beekman, of the Supreme Court, has appointed Frederick Southack receiver of the rents of 9-13 Maiden Lane, on the application of Frederick Ayer, in a

suit brought against Frank N. Gill to foreclose a second mortgage of \$233,000, on which the interest, due Dec. 12, it is alleged, has not been paid. It was also stated that the interest on the first mortgage, amounting to \$12,000, due Dec. 12, was not paid. The first mortgage is for \$600,000, and there is a third or creditors' mortgage for over \$75,000.

The Jewelers' Protective Union, the labor organization of journeymen jewelers, will hold their first annual ball Monday, Feb. 5, at the Grand Central Palace, 43d St. and Lexington Ave. The price of tickets will be 50 cents, and will admit gentleman and ladies. The ball will be in charge of the following committee of arrangements: Louis Traznek, chairman; N. Sussman, Geo. Peters, Frank Knaepple and R. Sheftel. This organization now report themselves to be in a better financial condition than for some time, and this is proved by the manner in which they are paying off the debts incurred during the recent strike.

The will of Jno. D. Brez, who, as told in THE CIRCULAR, Nov. 22, died suddenly at Clarens, Switzerland, Nov. 18, was filed for probate, Friday, in this city. Mr. Brez was the son of P. A. Brez, a leading watch importer of New York, and the deceased closed out the business of his father at the latter's death, in May, 1878. By the terms of the will of Jno. D. Brez, Jules Racine, Richard A. Schnabel and Elizabeth A. Gillet are named as executors. The estate, although the valuation is not given, is believed to amount to about a half million dollars. The principal bequests are to the deceased's sister, Mrs. Gillet, to whom he left his personal property and \$20,000 absolutely. She is also made the residuary legatee, and is to receive the income from the residue up to \$20,000 per year. A number of bequests are made to godchildren and friends in France, and a number of others of \$1,000 each are made to Swiss and American charities; \$1,000 is left to the poor of New York, another \$1,000 to the Swiss Benevolent Society of this city, and a third \$1,000 is left to the Huguenot Society, of which the deceased was a member.

INDEX TO ADVERTISEMENTS.

Aikin, Lambert & Co.....	2
Aikin, Lambert Jewelry Co.....	2
Alford, C. G., & Co.....	29
American Watch Case Co.....	28
American Waltham Watch Co.....	64
Arnstein Bros. & Co.....	64
Austin, John, & Son.....	64
Avery & Brown.....	44
Ballou, B. A., & Co.....	50
Bassett Jewelry Co.....	53
Bates & Bacon.....	54
Bell, O. E., Co.....	41
Bell Watch Case Co.....	27
Bigney, S. O., & Co.....	47
Blackinton, W. & S.....	32, 33
Borgfeldt, Geo., & Co.....	60
Bowden, J. B., & Co.....	8
Bradley Polytechnic Institute.....	64
Bryant, M. B., & Co.....	2
Chatham National Bank.....	37
Citroen & Janssens.....	44
Clark & Coombs.....	53
Clyde Line.....	38
Conley & Straight.....	64
Cook, Edward N.....	53
Cross & Beguelin.....	26, 36
Crossman, Charles S., & Co.....	39
Crouch & Fitzgerald.....	63
Crown and Lion Watch Cases.....	56
Day, Clark & Co.....	64
Deutsch Bros.....	2
Dorflinger, C., & Sons.....	37
Dubois Watch Case Co.....	54
Dueber-Hampden Co.....	15
Eaton & Glover Co.....	53
Eisenmann Bros.....	10
Elgin National Watch Co.....	21
Eliassof Bros. & Co.....	9
Esser & Barry.....	53
Fahys, Jos., & Co.....	4
Fairchild & Johnson Co.....	64
Field & Beattie.....	63
Foster, Theodore W., & Bro. Co.....	7
Frankel's Sons, Jos.....	7
Friedlander, R. L. & M.....	64
Fuchs, Ferd., & Bros.....	2
Goodfriend Bros.....	9
Goldsmith Bros.....	49
Gorham Mfg. Co.....	34
Hancock, Becker & Co.....	40
Harris & Harrington.....	64
Hedges, Wm. S., & Co.....	8
Heimberger & Lind.....	63
Hraba, Louis W.....	53
Imperial Mfg. Co.....	50
Jacot & Son.....	53
Juergensen, Jules.....	9
Juergens & Andersen Co.....	23
Kahn, L. & M., & Co.....	61
Knowles, Dr.....	63
Knowles, J. B. & S. M., Co.....	13
Kohn, Alois, & Co.....	64
Lapp & Flershem.....	16
Lederer, S. & B., Co.....	63
Ledos Mfg. Co.....	53
Levy, L. W., & Co.....	56
Malliet, C. G., & Co.....	8
Mathews & Prior.....	10
Mathey Bros., Mathez & Co.....	53
Mauran, John T., Mfg. Co.....	48
Mauser Mfg. Co.....	53
Mercantile National Bank.....	45
Meriden Britannia Co.....	11
Meriden Gravure Co.....	44
Mossberg & Granville Mfg. Co.....	25
Mount & Woodhull.....	8
Myers, S. F., Co.....	52
New England Watch Co.....	24
New Haven Clock Co.....	20
Oppenheimer Bros. & Veith.....	8
Pairpoint Mfg. Co.....	62
Potter, Wm. K.....	52
Reichhelm, E. P., & Co.....	64
Reisner, L. C., & Co.....	3
Rieh, H. M., & Co.....	53
Roy Watch Case Co.....	55
Rumpp, C. F., & Co.....	43
Saunders, John F.....	9
Schulz & Rudolph.....	9
Selwyn Importing & Trading Co.....	44
Sherwood, John W., & Co.....	14
Simmons, R. F., & Co.....	5
Simmons & Payne.....	53
Simons, Bro. & Co.....	2
Smith, Alfred H., & Co.....	10
Smith, B. & W. B.....	10
Standard Trading Corporation.....	62
Sternau, S., & Co.....	42
Stern Bros. & Co.....	9
Street, Geo. O., & Sons.....	52
Thomas, Seth, Clock Co.....	22
Towle Mfg. Co.....	50
Treibs Bros.....	42
Valier, S., & Co.....	51
Vrieslander & Moreels.....	42
Wallace, R., & Sons Mfg. Co.....	6
Westphal, W. C. A.....	52
Wheeler, Hayden W., & Co.....	12
Whiting, F. M., & Co.....	42
Wood, Chas. F., & Co.....	64
Wood & Hughes.....	53
Woods & Chatellier.....	44

# CLYDE LINE



## TO FLORIDA

ONLY DIRECT WATER ROUTE BETWEEN  
**NEW YORK, CHARLESTON & JACKSONVILLE**  
 WITHOUT CHANGE

SUPERB  
PASSENGER  
SERVICE

SAILING FROM  
 • PIER 45 N. R. •  
 NEW YORK

THREE  
SAILINGS  
WEEKLY

**Wm. P. CLYDE & Co., General Agents.**  
*Theo. G. Eber, TRAFFIC MANAGER, 5 BOWLING GREEN, NEW YORK.*

## Special Notices.

Rates 75c. per insertion for notices not exceeding 3 lines (25 words); additional words 2 cents each. If answers are to be forwarded, postage stamps must be enclosed. Two insertions, 15 per cent off; three insertions, 20 per cent off; four insertions or more, 25 per cent off. Payable strictly in advance.

Display cards on this page will be charged at \$2.00 per inch for first insertion, subject to same discount as above for subsequent insertions.

Under the heading of **SITUATIONS WANTED** on this page advertisements will be inserted for **One Cent a Word**, each insertion, no discount, but no advertisement will be inserted for less than 25 cents. This offer refers to **SITUATIONS WANTED ONLY**. Payable strictly in advance.

In all cases if answers are to be forwarded, 10 cents extra to cover postage must be enclosed.

## Situations Wanted.

**FIFTEEN YEARS' EXPERIENCE** as watchmaker and optician; good references; tools and trial case; open for position. Write, Box 314, South Manchester, Conn.

**PRACTICAL DESIGNER**, with 15 years' experience in all branches of sterling silver ware, desires position; All references furnished. Address "Sterling," care Jewelers' Circular.

**SUPERINTENDENT AND DESIGNER** with large experience in all branches of sterling silver ware desires position; best of references. Address "Designer," care Jewelers' Circular.

**SALESMAN IS OPEN** for an engagement; 15 years' experience; thorough knowledge of business; well acquainted with retail trade; highest reference. Address, J. R., care Jewelers' Circular.

**WANTED**—Position by an expert watchmaker; can do jewelry repairing; have 19 years' experience; best of references from leading watch houses of the trade. Address, B. B., care Jewelers' Circular.

**TRAVELING SALESMAN**, thoroughly experienced in the jewelry line, desires a position with a good house; young man; single; All references; will work for a low salary on the start. Address, "Salesman," care Jewelers' Circular.

**CATALOGUE MAKER AND ADVERTISER** of many years' experience, with knowledge of the jewelry business, desires to connect himself with good house; understands reaching buyers; highest references. Address, "Arthur," care Jewelers' Circular.

**WANTED**—Situation by a first-class watchmaker; 10 years' experience; 5 years with present house; can take charge of store or department; best of references; graduate of American Horological Institute. Address, A. C., care Jewelers' Circular.

## Help Wanted.

**WANTED**—First-class jewelry repairer, stone setter and engraver; one capable of helping with clock work preferred. C. L. Bryant, Danbury, Conn.

**WANTED**—A first-class jeweler and engraver; must come well recommended as to skill and character. Apply to C. F. Greenwood & Bro., Norfolk, Va.

**A FIRM** dealing in American watches and diamonds wants a competent stock clerk; one who is thoroughly posted in American watches. Apply with reference only, A. B., care Jewelers' Circular.

**A WATCHMAKER** who can do engraving, optical work and jewelry repairing; fair wages to start with; advancement according to ability; good references required. Address, A. Sachs, Albany, N. Y.

**A DIAMOND HOUSE** desires a first-class traveling salesman for the middle west; good salary to the right man; none need apply excepting those commanding a good trade. Address, "Importer," care Jewelers' Circular.

**WATCHMAKER** who is engraver, jeweler, salesman, stockkeeper and all-round helper with tools; steady job; send sample of engraving, and photo; state wages wanted and full particulars. Address, "Jeweler," care Jewelers' Circular.

**WANTED**—Experienced salesmen having an acquaintance with the jewelry and stationery trade, to sell fine line of gold pens, pencils, silver novelties, fountain pens, etc., for the middle western States. Address, Edward Todd & Co., 9 E. 16th St., New York city.

**WANTED**—FIRST-CLASS SALESMEN to sell on commission to retail trade our celebrated 14k. solid gold filled band rings of our own manufacture; these goods are put up in beautiful and expensive pyramid shape show cases; only experienced salesmen that sell other lines; exclusive right of State given; either \$100 indemnity or cash bond required for samples and faithful performance. Address, Arnstine Bros. & Mier, Cleveland, Ohio.

## Business Opportunities.

**JEWELRY STOCKS BOUGHT**—Retailers wishing to dispose of surplus or entire stock of diamonds, watches and jewelry can find quick, cash, strictly confidential buyer by addressing S. Marx, 22 Lispenard St., New York City.

**FOR SALE**—An old established (40 years) jewelry business, well located and in successful operation in New York city; work amounts to about \$8,000 annually; capital required, \$5,000 for tools, fixtures, stock, good will, etc.; an unusual opportunity for a good experienced workman; owner is established in another business; reference, L. J. Mulford, Jewelers' Circular Pub. Co. Address, M. J. M., care Jewelers' Circular.

## For Sale.

**FOR SALE CHEAP**—Two jewelers' trunks in good condition. Day, Clark & Co., 23 Maiden Lane, New York.

## To Let.

**OFFICE ROOM** to let to nice, quiet firm with us; terms \$25 per month. A. S. Gardner & Co., Room 73, Hays Building, 21 and 23 Maiden Lane.

**FRONT OFFICE**, 18x72 (occupied by the E. Howard Watch and Clock Co. for 14 years); also smaller offices and rooms for light manufacturing; rents low. Knapp Building, 41 and 43 Maiden Lane, New York.

## Legal Notice.

**ASSIGNEE'S SALE OF THE STOCK AND FIXTURES OF LOUIS COMBREMONT.**  
By JAMES McCAGLEY, Auctioneer,  
At 45 Maiden Lane, New York,  
JANUARY 23, 1900, at 10:30 A. M.  
Watch cases, springs, crystals, jewels, everything in watch materials; jewelers' tools and supplies; desks, safe, cases, etc. Catalogues on application to Purdy Van Vliet, Assignee, 87 Nassau St., New York. Mass & Goldberg, Attorneys for Assignee.

## Miscellaneous.

**WANTED**, by an eastern manufacturer of gold jewelry, desk room in New York office of one or more manufacturing jewelers in Maiden Lane or vicinity. Address, B. L., care Jewelers' Circular.

## WANTED—DIAMOND SETTER

and Jeweler. Must be a good setter, and able to do hard-soldering and general repairing. First-class wages and permanent position for a good man. Good references required.

HENRY KOHN & SONS,  
890 Main St., Hartford, Conn.

**TO LET,** SECOND FLOOR IN DECKER BUILDING,  
**33 Union Square, New York.**

SIZE: 30 X 130 FEET.

Fine Office, Show Room, Room for Polishing in rear. Possession in February.

Apply to **GEO. W. SHIEBLER** on premises.

## Seven Maiden Lane.

Floors and Offices to let

in this prominent centre of the jewelry, diamond and silverware trade; modern fireproof building with all conveniences; each office directly lighted and ventilated; possession at once. For full particulars apply to

E. A. CRUIKSHANK & CO., 141 Broadway.

## TO LET

IN THE

**UPTOWN JEWELRY and SILVERWARE DISTRICT,**  
UNION SQUARE, WEST,

From Feb. 1, for a term of years, No. 19, (second door above Tiffany's), large store, basement, first and second floors; separately if desired. Janitor on premises. Apply to

HORACE W. DAY,

17 STATE STREET, NEW YORK.  
TELEPHONE, 724 BROAD.

## CASH OFFERS.

If at any time you have offered to you by your customers any jewelry containing diamonds, pearls or other precious stones, and you do not care to buy them yourself, send them to us and we will submit an IMMEDIATE CASH OFFER. Trade and Bank References if desired. Established 1880. Correspondence solicited.

CHARLES S. CROSSMAN & CO.,  
3 Maiden Lane, New York.

## "TRADE-MARKS

of the Jewelry and Kindred Trades,"

with a Supplement just issued, contains

## Over 2,250 Marks

comprising every mark in the trade. Handsomely Bound in Cloth. Artistically Printed, Systematically arranged and Indexed.

Book and Supplement - \$3.00

THE JEWELERS' CIRCULAR PUB. CO..

11 John St., cor. Broadway, N. Y.

## SPECIAL NOTICES

IN THE

## Jewelers' Circular

PRODUCE THE

DESIRED RESULTS.

### Makes Himself Known After Being Considered Dead for 30 Years.

PHILADELPHIA, Pa., Jan. 16.—Jeweler C. F. Savage, of Bloomsburg, Pa., has received a letter from his brother, Alexander Savage, formerly a jeweler of Sunbury, who has been mourned as dead for 30 years. He writes that he is now living in Madrid, Spain, is an officer of high standing in the Spanish army and has amassed a fortune. He asked for an immediate reply by cable, which was sent, but up to this time nothing further has been heard from him.

Alexander Savage left Bloomsburg when young and embarked in the jewelry business in Sunbury. He soon tired of this venture and notified his brother to come and take charge of his business. When his brother arrived the shop was closed and Alexander gone. Nothing was heard of him for five years, when he wrote home



## B. & W. B. SMITH,

220 W. 29th Street.

### Wall and Counter Cases For Sale at a Sacrifice.

Suitable for Jewelers, Silversmiths,  
etc.

One of the Messrs. Smith will show them.

WM. S. EDGAR, Trustee.

from China that he was in the Orient, seeking a fortune. Thirty years have elapsed since that letter was written.

### Death of E. Chapman Maltby.

WALLINGFORD, Conn., Jan. 20.—The death of E. Chapman Maltby, which had been expected for several days, occurred last night at 10 o'clock. Some three months ago an affection of the nerve of the left eye developed and since that time Mr. Maltby had been gradually failing.

Mr. Maltby was born in Northford, Conn., and was 71 years old on Nov. 27. For years Mr. Maltby carried on in Northford the manufacture of woodwork for agricultural implements, axe helves being a specialty. Later on in the same place he conducted a business in the manufacture of spoons and also carried on the making of cocoanut dippers and desiccated cocoanut, he being the inventor of desiccated cocoanut which is used now so extensively. From Northford he moved the spoon and cocoanut business to Shelton, where he organized the firm of E. C. Maltby & Sons. Later on he was the founder of the Maltby, Stevens & Curtiss Co., in Shelton, who were burned out. He then moved here and did business in the Hall-Elton shop and later at factory P, of the International Silver Co., and then sold out to the Watrous Mfg. Co.

### J. George Bonny Makes Many Bequests.

SAN FRANCISCO, Cal., Jan. 17.—The will of J. George Bonny, for many years a member of Shreve & Co., has been filed for probate. The will is olographic in form and provides for the following bequests: To Mrs. Eliza G. Bonny Carslake, a sister, of Bordentown, N. J., 1,000 shares of the capital stock of Shreve & Co.; John Bruce Bonny, a brother, aged 83 years, living at 580 Franklin Ave., Brooklyn, N. Y., \$25,000; John Bruce Bonny, a nephew, \$25,000 and "all money due me from him at the time of my death;" Edwin L. Bonny, a nephew, living at Plainfield, N. J., \$25,000; Mrs. Mabel Abby Lewis Bonny, wife of John R. Bonny, Jr., \$20,000; George Bonny Lewis, of San Francisco, \$20,000. The residue is divided among Mrs. Eliza

G. Carslake and John Bruce Bonny in equal shares. All personal effects of the decedent are devised to Mrs. Carslake, she to dispose of them as she may deem best.

John R. Bonny, Jr., nephew of the decedent, is named as executor of the will without bonds. The value of the estate is not stated, but it is estimated to be not less than \$500,000.

### Proposed Canadian Legislation in the Line of Legitimate Merchandising.

TORONTO, Can., Jan. 20.—The annual meeting of the Toronto branch of the Retail Merchants' Association of Canada was held on the 17th inst., when there was a full attendance and much interest manifested in the programme of work outlined by president W. B. Rogers. He stated that among the legislation to be pressed for from the Provincial and Dominion Parliaments were bills for the proper equalization of taxation of various stores; for the abolition, so far as possible, of the gift and trading stamp schemes and similar illegitimate devices for attracting trade; making it a criminal offense to advertise goods as being different from what they actually are, either in weight, quality or price, whether through the press or by means of circulars, catalogues, etc.; also measures to prevent false stamping of goods; to protect the consumer from adulteration; and to make corporations equally responsible under the law for fraudulent practices as individuals.

A good deal of consideration was devoted to organization so as to bring the influence of the merchants throughout the country to bear upon the legislative bodies. W. B. Rogers was reelected president, and E. M. Trowern, secretary.

### Preparations for Philadelphia's Jewelers' Annual Banquet.

PHILADELPHIA, Pa., Jan. 20.—The first step of what is to be the biggest social event of the season in local trade circles was taken by the Philadelphia Jewelers' Club at a meeting last night, when the following members were appointed a committee of arrangements for the fifth annual banquet of the club: James H. Kelley, of Bailey, Banks & Biddle Co., chairman; William H. Long, with J. E. Caldwell & Co.; L. P. White; William P. Sackett, of Wanamaker's; William G. Earle; William J. Bruehl; William F. Parry, Jr., S. S. White Co.; Martin V. Burton, with William G. Earle; H. L. Roberts, Keystone Watch Case Co., and William Linker, Davis & Galt.

The first meeting of the committee will be held Jan. 22, when it will be definitely settled when and where the banquet will be given.

### Prosperity Brings Stability in Prices.

The Dueber-Hampden Watch Companies announce to the retail trade that no discount will be allowed from their list hereafter by jobbers, except a trade discount of 10 per cent and usual cash discounts.



DESIGNS, QUALITY, PRICES,

Small Profits and Large Sales

combined have created the  
great demand for the . . .

10k. and 14k. Gold Jewelry

MANUFACTURED BY

**HANCOCK, BECKER & CO.,**

Providence, R. I.

SOLD THROUGH JOBBERS ONLY.



**Philadelphia.**

**TRADE CONDITIONS.**

The movement to improve the volume of trade with the south is meeting with gratifying encouragement. The Trades League, Manufacturers' Club, Jewelers' Club and other commercial organizations are taking a keen interest in the project to enlarge business. The larger wholesale merchants are somewhat lukewarm as regards the alleged inequalities of the new rate schedule of the railway freight charges, but the small jobbers are strenuously "kicking." A demand is felt in the trade for a better quality of sterling silver toilet articles.

George Bruemmer has closed out his business at 1125 Columbia Ave.

Thomas D. Pearce, of Pearce & Feraille, has been made a director of the Dime Savings Fund.

Peyton Dearborn, formerly with Albert Sommer, is now with William H. Long, 1604 Pine St.

Maurice Pfaelzer, of Pfaelzer Bros. & Co., was elected Jan. 17 director of the Mercantile Club.

Frederick M. Simons, of Simons, Bro. & Co., Thursday withdrew as a candidate for re-election as a director of the Trades League.

Bridgeton jewelers have joined the Merchants' Association and will fight the demands of the Clerks' Union that stores be closed at 6 o'clock.

August Frech, watchmaker for H. O. Hurlburt & Sons, fell and broke his leg

last week and was removed to the Episcopal Hospital for treatment.

Henry P. Burchell has been arrested and held for trial on a charge of conspiracy with Mrs. Edith Townsend Everett, the newspaper writer, to victimize local department and jewelry stores.

George W. Scherr, formerly of L. A. Scherr & Co., was last week discharged as an involuntary bankrupt. Mr. Scherr is now in the employ of James D. Hughes, jobber, 728 Chestnut St.

The application for the discharge of B. Frank Williams, who while trading under the name of D. F. Conover & Co. was adjudged a bankrupt, was heard in the United States District Court Friday. The creditors of the jobber were present and were examined. The Court withheld decision.

**Pittsburgh.**

Henry Barrett is in New York on a business trip, and expects to remain some time.

Harvey Wallace, of Smith's Ferry, Pa., has recovered from a severe attack of typhoid and was in the city last week.

W. C. Siegfried, Youngstown, O., whose recent business difficulties involved some local firms, has applied for a discharge from bankruptcy.

Frank Hartman, of West, White & Hartman, has been ill at home with sciatic

rheumatism. Earl J. G. Logan, formerly with E. C. Bates, Alliance, O., is now with this firm.

N. De Roy & Co., formerly in business on Penn Ave., will open a new store at the corner of Smithfield St. and Second Ave. The firm are making extensive and handsome improvements.

Out-of-town buyers in the city last week were few, and included: George Eckert, Jeannette, Pa.; Harry B. Cubbison, New Castle, Pa.; E. H. Schaefer, Beaver Falls, Pa.; E. H. Kemmerdell, Tarentum, Pa.; Mrs. L. C. Brehm, West Newton, Pa.; A. C. Gaul, Sharpsburg, Pa.

The death of Mrs. Caroline Roberts, wife of the late Maj. W. W. Barker, a prominent jeweler, occurred on Jan. 14. Mrs. Barker was the sister of the late J. M. Roberts, Sr., who established the well known jewelry store on Fifth Ave. and Market St. She was the aunt of Steele F. Roberts and Charles Roberts, of the firm of E. P. Roberts & Sons, and of John Roberts, Market St.

**Syracuse.**

At the annual meeting of the stockholders of the Joseph Seymour Mfg. Co., held recently, the following directors were elected: Francis W. Gridley, William H. Stansfield, Edward H. Burdick, Edwin G. Seymour and Richard Sutcliffe. Following the stockholders' meeting the directors

**THE "IS-A-BELL"**

is a Bell—that means a remarkable seller. It is rapidly taking the place of guard chains. You can always sell a later style, and this one the best of all. It can be worn on any dress and in many ways—a new idea for each dress. It is made in Plate, 14k. Gold-Filled, Solid Gold and Sterling Silver, with and without chatelaine articles. An endless variety of designs, all good. Send for sample and illustrated sheet.

**OUR RIGHTS will BE PROTECTED** against all imitators or parties handling imitations.

**The O. E. BELL CO.,**  
Manufacturers and Patentees,  
FACTORY: MANSFIELD, OHIO.  
**CINCINNATI, OHIO.**

OTTO K. TREIBS.

PAUL E. TREIBS.

**TREIBS BROS.,**

68 Nassau St., New York.

139 Mathewson St.,  
Providence, R. I.

CUTTERS AND IMPORTERS OF

**Opals.**

F. E. TREIBS,

Oberstein, Germany.

ESTABLISHED 1842.

HERMANN TREIBS.

ALBERT TREIBS.

EMIL TREIBS.

**Vrieslander & Moreels,  
Commission Merchants.**

We buy Rough Diamonds  
for 1 per cent commission.  
We cut Melées specially  
for the American market.

Best New York References.  
Correspondence Solicited.

Temporary address,  
5 Rue Van Lier,  
ANTWERP, BELGIUM.

**STERLING  
SILVER  
GOODS ONLY**



**FRANK M. WHITING & CO.**

**SILVERSMITHS**

**NORTH ATTLEBORO  
MASS**

1128 B'WAY, NEW YORK.  
220 SUTTER ST. SAN FRANCISCO.

met and elected the following officers: President, Francis W. Gridley; vice-president, William H. Stansfield; secretary and treasurer, Edward H. Burdick; general manager, Edwin G. Seymour.

The Grand Jury, sitting in connection with the January Trial Term of the Supreme Court, has found an indictment of burglary in the third degree against William O'Brien, George Dietsch and John Collins. They are the three young men who are charged with entering the jewelry store of Charles H. Miller, Nov. 12, 1899.

Sidney W. Moore, Stephen C. Waterman, William W. Swayze, Solomon A. Campbell and Charles A. Stringer were elected directors last Tuesday afternoon, at the adjourned annual meeting of the stockholders of the Oneida Silverware Mfg. Co. Subsequently Mr. Moore was chosen president by the directors; Mr. Swayze, vice-president, and Mr. Campbell, secretary and treasurer.

**Boston.**

Mrs. Nelson H. Brown is in New York on a business trip.

President C. W. Davidson, of the Thomas Long Co., has been in New York the past week on a business trip.

Among the visitors in town last week was A. A. Abbott, manager of Smith, Patterson & Co.'s Montreal branch.

P. H. Ackerman, who recently underwent a surgical operation at the hospital, is convalescent, and was able to return to his home a short time ago.

Charles T. Saul, retail optician, Waltham, has liabilities of \$1,551 and assets amounting to \$276, and his case will be settled under the bankruptcy law.

M. N. Smith, of Smith, Patterson & Co., accompanied by Joseph C. Bachelder, of the glass, silver and bric-à-brac departments, are in New York on a buying trip.

H. W. Patterson, of Smith, Patterson & Co., who was one of the Boston contingent at the jewelers' dinner in New York, was accompanied to that city by Mrs. Patterson, and will remain throughout the week.

S. C. Eppenstein, of the Illinois Watch Case Co., Elgin, Ill., was in Boston the past week, introducing A. M. Stevens, who is to represent the company in this section as traveler for the house to the Boston trade.

Thomas S. Butler, who was arrested last week in Worcester, charged by Ezra E. Rubin, a Boston retail jeweler, with complicity in the larceny of a diamond ring, satisfied the Judge of the

Municipal Court that the arrest was unjustifiable and the case was not pressed.

George B. Owen, manager for the Wm. L. Gilbert Clock Co., was in Boston shortly after the fire in their Boston representative's office, making arrangements for re-occupancy of the premises as soon as necessary repairs can be effected.

Buyers in town the past week included: W. H. Elliott, Pawtucket, R. I.; N. A. Frost, Hanover, N. H.; W. A. G. Smith, Rockland; J. F. Dodge, Providence; L. R. Hapgood, Westboro; Harry Butler, Bangor, Me.; J. M. Dewyea, Nashua, N. H.; C. W. Wilcox, Milford; Mr. Bogle, of Bogle Bros., White River Junction, Vt.; S. N. Follansbee, Leominster; A. W. Gunnison, Hudson.

By agreement of counsel in the suit brought by Henry Dobbins, jeweler, and other Meigs railway stockholders to recover \$400,000 to be paid them for the Meigs franchise, the case was dismissed at a brief hearing in the Supreme Court last Wednesday. Another action will be substituted therefor and a hearing granted in due time. The \$400,000 was to have been paid, according to original agreement, by J. P. Morgan.

Morrill, Clough & Thayer have dissolved the partnership formed by them a few months ago, and Alvin T. Morrill will continue in business at the firm's location in the Marlboro building. By the terms of the dissolution Mr. Morrill acquired the location and accounts receivable, while Messrs. Clough and Thayer have the stock on hand and assume the accounts payable. Mr. Morrill will proceed to put in a new stock and continue the business. Temporary suspension of the removal of their stock by Messrs. Clough and Thayer was brought about subsequent to the change in the firm by the Crescent Watch Case Co.'s action in attaching the stock for an account last week, but this was considered likely to be removed speedily.

**Baltimore.**

Gustav Walbrecher, manager of a jewelry store, applied for the benefit of the bankruptcy law in the United States District Court Jan. 15. His liabilities are \$3,604.86 and assets \$100.

Cornelius B. Collins, watchmaker and jeweler, was locked up last week charged with the larceny of a number of watches. The timepieces were, it is alleged, obtained from the owners July 29 last for the purpose of being repaired. They were valued at about \$400. Collins went through the country working at his trade.

**S. STERNAU & CO.,**

204 CHURCH STREET, NEW YORK.

Manufacturers of **METAL WARES**

in Brass, Copper and Silver.

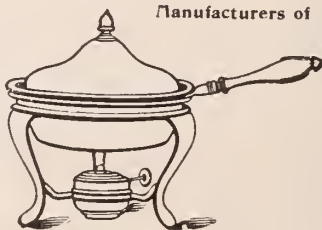
**CHAFING DISHES,  
KETTLES, TRAYS,**Crumb Trays and Scrapers, Bread  
Baskets, Etc.

CATALOGUE ON APPLICATION.



## Our Traveling Representatives



Traveling representatives may consider these columns open for the publication of any news or items of interest regarding themselves or their conferees.

Percy D. Lucas, who travels through New England, New York and Pennsylvania for the Mauser Mfg. Co., New York, having recovered from his recent illness, will commence his trips through the same territory, Feb. 1, 1900.

George A. Stockder, traveling salesman for the J. D. Bergen Co., Meriden, Conn., left Jan. 18 on a six weeks' western trip.

George West, of West, White & Hartman, Pittsburgh, Pa., starts out this week on his usual route. James Brown, for Geo. B. Barrett & Co., Pittsburgh, Pa., left on Monday on his trip which includes eastern Ohio.

S. K. Jonas, representing I. W. Friedman, 172 Broadway, New York, left Sunday night for a trip through the south.

Sol Sickles, of M. Sickles & Sons, Philadelphia, has started on a long trip throughout Pennsylvania, Delaware, New Jersey and Ohio.

M. D. Smith has made arrangements to continue to represent the S. B. Champlin Co., Providence, R. I., in Wisconsin, Michigan, Minnesota and Pennsylvania.

A. H. Clinger, traveler for T. G. Hawkes & Co., Corning, N. Y., stopped a day in Chicago last week before continuing his trip west. Mr. Clinger spent his holidays in Canada in hunting and fishing, and reported plenty of game.

Visitors in the Hub the past week included: George B. Osborn, William Smith & Co.; Mr. Adler, New Jersey Lamp & Bronze Works; Col. John L. Shepherd, Keystone Watch Case Co.; president G. W. Wells, American Optical Co.

C. M. Stone, H. E. Vincent, H. L. Sherman, W. O. Adams and J. H. White, who heretofore have traveled from the Chicago office of the Simpson, Hall, Miller & Co. branch of the International Silver Co., will hereafter travel from Factory L, in Wallingford, Conn.

Among the traveling representatives seen in Indianapolis, Ind., last week were: William Bosselman, T. Quayle & Co.; Daniel Wile, Buffalo Jewelry Case Co.; J. T. Metcalf, R. Blackinton & Co.; William W. Middlebrook, B. A. Ballou & Co.; George Pearce, Bay State Optical Co.; John A. Keane, Ostby & Barton Co.; Mr. Haskins, T. I. Smith & Co.

The following traveling salesmen passed through Detroit, Mich., last week: Mr. Klipper, Hipp. Didisheim & Bro.; L. P. Cook, J. F. Fradley & Co.; K. D. Yeaton, S. Sternau & Co.; L. V. Benson, LaPierre Mfg. Co.; D. Wile, Buffalo Jewelry Case Co.; W. H. Hamill, Leys, Christie & Co.; C. S. Williams, Landers, Frary & Clark, and Mr. Huss, S. & A. Borgzinner.

The following is a list of the eastern travelers who arrived in San Francisco, Cal., last week: F. C. Simes, S. O. Bigney & Co.; Everett I. Rogers, Parks Bros. & Rogers; R. J. Sickles, Arms Mfg. Co.; I. W. Smith, Horton, Angell Co.; Jere Milleman, Courvoisier-Wilcox Mfg. Co., and the Wm. W. Hayden Co.; William Jarchow, Langfeld Bros. & Co.; Mr. Marsh, C. A. Marsh & Co.; H. E. Cobb, Daggett & Clap Co., and the Lawton-Sherman Co.; Mr. Sandfelder, D. F. Briggs Co., and Mr. French, Riley, French & Heffron.

Travelers in Pittsburgh, Pa., last week were: Fred J. Foster, Unger Bros.; Theo. G. Walpuski, American Morocco Case Co.; Alva J. Lasher; W. C. Tappan, The D. F. Briggs Co.; W. H. Race, International Silver Co.; B. Hyman, Hirsh & Hyman; Mr. Stevens, Illinois Watch Case Co.; Mr. Rounds, Hancock, Becker & Co.; Frank S. Goff, Bennett & Bradford; George H. Remington, Waite, Mathewson & Co.; Mr. Sinnock, Ehrlich & Sinnock; Mr. Walton, The Wadsworth Watch Case Co.; F. W. Collom, J. D. Warren & Co.; J. Fred Crane, Mandeville, Carrow & Crane.

The vanguard of the army of salesmen from the Attleboros which has been out and invaded the west is beginning to reach home. Maxy W. Potter, of J. M. Fisher & Co., is one of the first to

show up at the home office and he has had a very successful trip. Arthur J. Wilson, for P. J. Cummings & Co., is another who has gotten back from a very satisfactory tour. Statements fully as encouraging will be heard from all the men as they come in, and the shops, running full time and with increased force, bear witness to their enterprise.

The following traveling men visited the dealers of Columbus, O., within the past few days: F. C. Winship, T. B. Clark & Co.; O. Bartel, The Western Clock Mfg. Co.; Adolph Rosenthal; Louis Freund, Henry Freund & Bro.; H. L. Sherman, Simpson, Hall, Miller & Co.; Theo. G. Walpuski, American Morocco Case Co.; E. T. Straw, Goddard, Hill & Co.; F. A. Perry, The John Russell Cutlery Co.; Robt. B. Steele, J. B. Bowden & Co.; Fred J. Foster, Unger Bros.; C. L. Krugler, Champenois & Co.; F. L. Baker, Hayden W. Wheeler & Co.; J. R. Brown, George B. Barrett & Co.

Among travelers in St. Louis, Mo., last week were: C. S. Untermeyer, Chas. Keller & Co.; Lewis P. Cook, J. F. Fradley & Co.; F. E. Whitmarsh, Alvin Mfg. Co.; John Glossinger, Wm. Demuth & Co.; Mr. Boice, White & Major; R. H. Harris, Ansonia Clock Co.; J. S. Adler, J. S. Adler & Co.; J. F. Dengler, E. P. Dutton & Co.; W. F. Adams, Simpson, Hall, Miller & Co.; L. E. Fay, R. F. Simmons & Co.; J. R. Payne, Buffalo Jewelry Case Co.; O. H. Hull, Pairpoint Mfg. Co.; Harry Osborne, R. Wallace & Sons Mfg. Co.; L. Strassburger, S. Sternau & Co.; H. C. Barker, Mandeville, Carrow & Crane; T. H. B. Davis, International Silver Co.; S. A. Goldsmith, Adolph Goldsmith & Son; J. F. Dean, Reed & Barton; Mr. Weil, Electric City Box Co.; O. A. Schneider and Emil Pick, Hammel, Riglander & Co.; Geo. Southwick, Union Braiding Co.

### Pacific Coast Notes.

J. Luedke has reopened his jewelry store at Healdsburg, Cal.

C. H. Leppla, a jeweler of Cripple Creek, Col., has been succeeded by Lyman Bros.

D. M. Eshback, watchmaker, Sonoma, Cal., died at that place last week. He was

a native of Pennsylvania, aged 65 years, and had lived in Sonoma 16 years. Death was due to heart failure.

A. Dobrowsky, Redding, Cal., is at his place of business again, after a week of sickness.

J. A. Maurer has sold the post office jewelry store at Flagstaff, Ariz., to J. P. Arnolds, and the latter has moved his stock from the Western Union building to the post office.

The Diamond Palace, 105 and 107 E. Main St., Stockton, Cal., is undergoing a number of improvements. A modern optical parlor is being installed in the rear of the store.

Some of the decorations in one of the windows of Chas. C. Zilles & Co.'s jewelry store, Pomona, Cal., caught fire last week, and before the flames could be extinguished the goods in the window were damaged to the amount of \$50.

### San Francisco.

F. H. McConnell has removed from the Lick hotel to 114 Post St.

A. M. Armer, of Armer & Weinschenk, started out last week on an extended business trip.

M. Saier, Fresno, Cal., was in San Francisco last week, spending a part of his honeymoon.

Emile Joseph, Ukiah, Cal., is reported to have recently enlarged his store and increased his stock of goods.

A. W. Huggins, of A. I. Hall & Son, will leave for New York about Feb. 1. His headquarters will be at 10 Cortlandt St.

### TO THE TRADE:

We herewith beg to inform our customers that we have sold our entire interest in the well-known Bag Frame No. 397487 to Messrs. C. F. RUMPP & SONS, Philadelphia, who will in future furnish finished bags in a large variety of leathers. Messrs. C. F. RUMPP & SONS will also have the sole control of all Mountings manufactured by us for Fancy Leather Goods.

The reputation of this house needs no comment from us and we are confident that any orders sent to them will receive the best attention.

Yours truly,

WM. B. KERR & CO.

NEW YORK, January 2, 1900.



# A. & B.

## HEADQUARTERS

FOR

## Waltham Watches

EVERY GRADE.

## AVERY & BROWN,

68 Nassau St., New York.

THIS IS THE SEASON  
TO RENOVATE YOUR

# Catalogue

DROP US A POSTAL  
AND WE WILL BE  
PLEASED TO FUR-  
NISH ESTIMATES FOR  
YOUR WORK.

MERIDEN GRAVURE CO.,  
MERIDEN, CONN.

## Novelties for Men



TRADE-MARK.

In 14 Kt. Gold, Sterling Silver and  
Ornamented with Jewels.

## Woods & Chatellier,

860 Broadway, N. Y.

42-46 Hill St., Newark, N. J.

## Selwyn Importing & Trading Co.,

14 East 17th St., New York.

Novelties in Stag  
Hooks, Boars' Tusks  
and Ivory.

Ebony Goods,  
Cut Brushes for  
Mounting.

## CITROEN & JANSSENS,

Diamond Cutters and Polishers for the Trade.

Special attention given to repairing stones.

415 to 419 Race St., CINCINNATI, OHIO.

Jewelers' Company Entrance.

DON'T FORGET THE JEWELERS' CIRCULAR PUBLISHING CO'S BOOK LIST when in want of any technical work in the Jewelry or Kindred Trades.

### Providence.

On Feb. 8 the Ostby & Barton Mutual Relief Association will give a ball in this city.

T. E. Carpenter, formerly engaged in the manufacture of rings, is now engaged in the manufacture of cigars on Stewart St.

Silas H. Manchester, of Fessenden & Co., was elected a member of the board of trustees of the Rhode Island Horticultural Society last week.

B. M. Graffam, engraver, has removed to 206 Weybosset St. from Pine St., and Ole B. Owren, enameler, has removed to 19 Page St. from Friendship St.

The local trade are considerably interested in the failure of the Wild Bros. Jewelry Co., St. Louis, Mo. It came wholly unexpectedly, so far as the local trade were concerned, and it is understood that the jewelers of Providence and vicinity are interested to over \$30,000.

On Wednesday morning last a hearing on the petition of Albert A. Remington, assignee of the Campbell-Metcalf Silver Co., for additional compensation for services rendered, was given before Lorin M. Cook, Registrar in Insolvency. The claims of Mr. Remington were presented and received the consideration which it was felt was due them. At the conclusion of the hearing Registrar Cook announced that he would hold the matter under advisement.

### The Attleboros.

The Commonwealth Jewelry Co. is the name of a new mail order concern in North Attleboro.

M. Bauman, of the L. Bauman Jewelry Co., St. Louis, Mo., called on the manufacturers of the Attleboros last week and placed orders.

Jesse Carpenter, Arlington, N. J., head of the New York office of the Horton, Angell Co., called last week at the Attleboro factory of the house.

William H. Goff, Jr., head of the Hunt Jewelry Co., of Attleboro, was the unanimous choice of Co. I, Fifth Massachusetts Infantry, for captain last week.

Henry A. Thurston, of Allen, Smith & Thurston, who has been confined to his bed for many weeks with illness, was able to be about the house last week.

The new refinery opened on Union St. by George M. Baker, of Providence, as a local branch of his own plant, has been styled the Attleboro Refining Co.

Arthur Macdonald who recently opened an engraver's shop, has attracted attention the past few days by turning out some very artistic book plates as gifts to friends.

Clarence M. Powers, an Attleboro jeweler, who has been undergoing treatment at the Massachusetts General Hospital, died there last week. He was well known in jewelry circles himself, as are his brothers.

Mrs. Albert Read, who died last week in Lakeport, N. H., was buried in South Attleboro. Forty years ago her husband was in business at Attleboro Falls, and is remembered by some of the older members of the trade.

At the office of the late Elton I. Frank-

lin the announcement is made that E. I. Franklin & Co., as a manufacturing house, will continue uninterrupted. Mr. Franklin's partners will continue the business and the estate will hold the interest formerly held by Mr. Franklin.

Herman Ackermann, formerly of Ackermann & Maher, South Attleboro, has become the partner of George H. Randall, late salesman for P. S. Eddy, Providence, in a new manufacturing house. The young concern has taken quarters in the Wilmarth building, Attleboro.

The local press in Attleboro has revived the report that Joseph M. Bates, of Bates & Bacon, is to erect a new jewelry factory in the Spring. Mr. Bates replied to the representatives as he did to the representative of this paper weeks ago that he had the plan, but had not decided when to put it in operation; certainly not until he saw a greater need than now exists.

The Curtin Jewelry Co., Harrison C. Swift, proprietor, have made an assignment to Samuel M. Einstein, head of the Attleboro Mfg. Co. Mr. Einstein sold the business to Mr. Swift, and in the failure of the latter to run it profitably it has reverted into Mr. Einstein's hands. The settlement has been left in the hands of attorney G. A. Adams, Attleboro, and Judge Fox, Taunton.

A strong organized movement has been instituted among the jewelry operatives of Attleboro to raise a large subscription fund for the widows and orphans of the British soldiers who fall fighting Oom Paul. The movement started among the scores of English-Americans employed by the Watson & Newell Co., and has been taken hold of with enthusiasm and business method.

Harold E. Sweet, head of the selling department of R. F. Simmons & Co., was married last Tuesday in Detroit. With him on his western trip were his father, J. Lyman Sweet, head of the firm; Raymond M. Horton, recently retired from Walch & Horton, and Roland M. Lamb, eldest son of Louis J. Lamb, of C. H. Allen & Co. The two young men are college friends of Mr. Sweet and went to act as ushers.

### Newark.

Fred T. Weigle and Ernest A. Rose have formed a partnership as Weigle & Rose for the manufacture of a fine line of set rings. Their address is 61 Arlington St.

The sale of the jewelry business of William H. Ball & Co., 211 Mulberry St., was consummated Jan. 17, the purchasers being S. A. Kent, of East Orange, and A. Linden Woodland, of this city, who will continue the business under the name of Kent & Woodland.

H. C. Milligan, jeweler of Keosauqua and New London, Ia., will remove the business of both stores to Knoxville, Ia., where he will locate early in February. Here Mr. Milligan will have one of the largest jewelry stores in Iowa, and will open up for business about Feb. 3, at which time he will present souvenirs to visitors to the store.



**Canada Notes.**

T. Baker has started a jewelry business in Hamilton, Ont.

John Welsh & Son, Stratford, Ont., have enlarged their premises.

M. Sherry, representing Joseph Fahys & Co., was in Toronto last week.

W. C. Gibson, jeweler, St. John, N. B., has given a bill of sale for \$138.

A. Gibson has purchased the jewelry business of W. H. Pletsch, Hanover, Ont.

J. E. Barre, of Barre Bros., Halifax, N. S., has gone on a business trip to Winnipeg.

Alex. Gibson, Hanover, Ont., has given a chattel mortgage for \$386 to A. B. Kaiser.

Dr. W. W. Chalmers has purchased the jewelry business of E. Buzzell, Magog, Que.

Wm. J. Fanall, jeweler, Fort William, has given a bill of sale for \$60 to L. Walsh.

The Tate Optical Co., Peterborough, Ont., are installing electrical power in their factory.

Jas. A. Pitts, Montreal, accompanied by Mrs. Pitts, is in New York on a purchasing trip.

A. W. Stevenson has been appointed curator of the estate of J. B. Williamson, Montreal.

Lefevre & Tachereau have been appointed curators of the estate of P. E. Poulin & Co., Quebec.

The offer of E. G. Amy, Cobden, Ont., of 20 cents on the dollar has been accepted by the principal creditors.

The death occurred in Toronto a few days ago of A. D. Benjamin, a director of the Toronto Silver Plate Co.

The marriage of John W. Wilson and Miss Elizabeth Stevenson Eaves took place recently in Montreal.

The death occurred recently of Mrs. Nye, widow of the late Henry Nye, who was a jeweler at Halifax, N. S.

M. C. Ellis, of P. W. Ellis & Co., Toronto and Montreal, paid his first visit to the Montreal branch last week.

John R. Leggett, watchmaker, Parry Sound, Ont., has given a renewal chattel mortgage to Telfer Bros. for \$98.

W. J. Barr, manager of the Goldsmiths Stock Co., Toronto, has gone on a purchasing trip to New York and eastern jewelry centers.

Canada exported to the United States in September, 1899, jewelry to the value of \$175; in September, 1898, \$38, and in September, 1897, \$152.

The jewelry and watches and manufactures of gold and silver entered for consumption at the port of Montreal for December last amounted to \$29,945 against \$29,383 for December of 1898.

W. R. Davis has opened a commission and jobbing office at 28 W. King St., Hamilton, with a good jewelry line on hand. He intends to sell direct to the public.

Ryrie Bros., Toronto, got the contract for silver souvenir matchboxes for presentation by the city to the members of the second Canadian contingent for South Africa.

Joseph M. Brown, jeweler, Nanaimo, B. C., combines patriotism and advertising after a style much in vogue just now, by stamping every letter he sends out with "Rule Britannia" in big letters.

The exports of clocks and watches from the United States to Canada for September, 1899, amounted to the value of \$32,057; for September, 1898, they amounted to \$30,879, and for September, 1897, to \$20,875.

Arthur Pequegnat, Berlin, contemplates disposing of his jewelry business and devoting himself exclusively to bicycle manufacturing, having already an establishment in that line which demands all his attention.

The Optical Institute of Canada, Toronto, has arranged an advanced class in retinoscopy for one week commencing Jan. 29, including teaching with regard to muscular troubles and the use and abuse of prisms.

Sheffield manufacturers of ivory handled table and dessert knives, carvers and steels and certain other lines of cutlery known as garret goods, have advanced their price 10 per cent. Canadian jobbers are following the advance.

P. E. Poulin & Co., jewelers, Quebec, have assigned with assets of \$4,100 and liabilities of \$4,491. The principal creditors are: P. W. Ellis & Co., Toronto and Montreal, \$356; T. R. Ridgeway, \$462; J. D. A. McCaskill, \$322, and Jas. A. Pitts, \$205, all of Montreal.

R. J. E. Scott, chief time superintendent of the Canadian Pacific Railway system, has just returned from a tour of inspection over the line. Prof. McLeod, chief superintendent of the Grand Trunk Railway time service, has also just returned from a tour of inspection.

The Toronto trade has benefited greatly by the increase in the price of diamonds owing to the Transvaal war, several dealers, foreseeing the rise, having bought unusually heavily during the last year. A conservative estimate by a leading firm gives the value of diamonds now in stock in Toronto at \$250,000.

Jas. Eastwood, wholesale jeweler, New Glasgow, N. S., left for Boston on the 15th inst., and met A. R. Harmon, manager of the American Waltham Watch Co., in Canada, on the 16th inst. Mr. Eastwood, who is on a purchasing trip,

is enthusiastic concerning trade prospects in the Dominion during the coming year.

The estate of J. B. Williamson, Montreal, who recently assigned, is said to have been considerably impaired by the heavy rates paid note shavers in recent financing operations. C. H. A. Grant, of the Montreal Watch Case Co., has been appointed provisional guardian. It is understood that P. E. Poulin & Co., of Quebec, are involved to some extent in this failure.

The Dueber Watch Case Mfg. Co., Canton, O., Jan. 6, at Osgoode hall, Toronto, obtained leave to appeal from the judgment of the Court of Appeal, dismissing their judgment against Chas. A. Campbell and Frank Taggart for a certain sum of money for goods. The Court of Appeal held that they had no cause for action and they now seek to obtain the opinion of the Supreme Court.

The Winnipeg *Commercial* notes a decided expansion in the demand for gift goods. Compared with last year reports show all the way from 25 to 100 per cent increase in the volume of sales, while in the matter of prices and profits there has also been a much better showing. Jewelry goods were especially favored, quality being considered more than ever before, and the price question for the most part being given a second place.

Assistant Superintendent Crowe, of the Canadian Secret Service, marched into the Montreal police court on Wednesday last with Abraham Brodsky. Brodsky is in the diamond peddling business. He went away to British Columbia last Summer, and Alfred Eaves, jeweler, of Montreal, let him have 11 diamond rings, valued at some \$500, to dispose of on his trip, with the understanding that he should return either the diamonds or their equivalent in money when he came back from his travels. Brodsky, it is alleged, did neither.

The Sherbrooke (Que.) jewelry and allied trades were prosperous the past year, as will be seen from the following: R. J. Spearing, manufacturing jeweler, says: "Our Xmas trade was very brisk. November was dull owing to the bad weather. However, everything was as good, all round, as last year." A. C. Skinner, watchmaker and optician, says: "My business was 25 per cent better than the year before, according to actual figures, and the year before was 30 per cent better than the year preceding." Lewis Smith, jeweler, says: "Business for two or three years past has been better than it was before for several years. People appear to have more money, wherever they get it. For the past two or three years things have been picking up right along."

## The Mercantile National Bank

OF THE CITY OF NEW YORK,

BROADWAY AND DEY STREET,

Solicits Accounts from the Jewelry Trade.

THE EMPIRE BUILDERS TAKE ITS WAY!

# WESTERN SUPPLEMENT

## THE JEWELLERS' CIRCULAR

VOL. XXXIX.

NEW YORK, WEDNESDAY, JANUARY 24, 1900.

No. 26.

### Chicago Notes.

All communications in reference to the Chicago department of *The Jewellers' Circular*, addressed to Stephen Parlin, 134 Van Buren St., Room 414, Chicago, will receive prompt attention.

Peter Lapp, of Lapp & Flershem, has left for an extended tour of Mexico.

Chas. Hoefer, of Woodstock, Hoefer & Co., Kansas City, was a visitor here last week.

P. J. Burroughs, jewelers' auctioneer, has returned from a two weeks' visit with relatives in Fremont, O.

W. J. Miller, manager of the Chicago office of the Seth Thomas Clock Co., has returned from a business trip to Kansas City, Mo.

Charles Ham, Frankfort, Ind., is making arrangements for a hunting trip to Arkansas, where he will try his pack of English setters.

A. C. Becken has left for a six weeks' vacation on his ranch at the foot of the Black Range mountains, New Mexico, where he has extensive interests.

Herbert Crompton, who has been with the F. C. Happel Co. more than 17 years, has been appointed jewelry buyer for that house, succeeding Ed. Hoffman.

S. L. Loewenstein, many years with the Bauman-Massa Jewelry Co., St. Louis, Mo., has accepted a position as city salesman for the Stein & Ellbogen Co.

W. O. Kellogg, manager of the Chicago office of the A. F. Towle & Son Co., has left for Greenfield, Mass., and a visit to his former home in Rochester, N. Y.

Schrader-Wittstein Co. have incorporated with a capital of \$75,000, to manufacture jewelry. Incorporators: Ida Schrader, Alfred H. Wittstein, Charles T. Wittstein.

M. N. Berg, Duluth, Minn., was here last week replenishing depleted stocks. Mr. Berg reports excellent business in his vicinity, with fine prospects for the coming year.

Crown Mfg. Co., of Chicago, have incorporated with a capital of \$10,000 to manufacture jewelry; incorporators, Percival Steele, L. W. Thompson and Charles E. Selleck.

Robert W. Morris, manager of the Chicago office of the R. Wallace & Sons Mfg. Co., has returned from a 10 days' visit to the factory and the New York office of the company.

Ed. A. Manheimer, New York agent for L. Manheimer, returned to New York Saturday after a three weeks' visit to the Chicago office. "We are unable to get enough goods," said Mr. Manheimer.

Frederick L. Merrick, manager of the Chicago office of the Bradley & Hubbard Mfg. Co., has been nominated a member of the board of directors of the Chicago Athletic Association. There is only one ticket in the field.

Geo. W. Payson, with the Seth Thomas Clock Co., has returned from a trip through the central west. He says western jewelers report a heavy holiday trade and bright prospects for a banner year. He left Saturday for a flying trip to St. Paul and Minneapolis.

Goldsmith Bros., refiners, recently bought a pair of solid gold half-oval bracelets weighing 300 pennyweights. They were secured from a jeweler who had purchased them from a soldier who had got them in the Philippines. They were almost as thick as a man's thumb.

Madeline E. Kern has filed suit for a divorce from Peter E. Kern, who, she alleges, left her in November, 1898, and is now a jeweler in Skagway, Alaska, possessed of a stock of goods and personal property and earning large sums of money. She asks for \$70 per month for the support of herself and daughter.

The Illinois Watch Case Co. will open an office in the Gill building, New York, about Feb. 15. A. M. Stevens, five years with Enos Richardson & Co. and previously nine years with H. Muhr's Sons, will have charge of it. Mr. Stevens is a pushing and energetic salesman and is greatly pleased with the line which he inspected here last week. He and S. C. Eppenstein, of the company, left for the east last Saturday night.

Buyers in the city recently were G. A. Klein, Duluth, Minn.; N. E. Benoit, Rockford, Ill.; A. K. Camp, Milwaukee, Wis.; W. P. Ballou, De Kalb, Ill.; John S. Truscott, Miles City, Mon.; C. D. White, Minneapolis, Minn.; W. H. Upmeyer, Milwaukee, Wis.; E. Epstein, Oshkosh, Wis.; C. H. Coale, Sandwich, Ill.; J. W. Neasham, Ottumwa, Ia.; Geo. E. Feagans, Joliet, Ill.; Thomas Juzek, Elgin, Ill.; Frank Le Bron, Keokuk, Ia.; Will H. Beck, Sioux City, Ia.; Andrew Rovelstad, Elgin, Ill., and J. C. Klaholt, Springfield, Ill.

H. Anderson, jeweler, 177 E. Chicago Ave., was robbed Thursday of a diamond ring valued at \$200. While Mr. Anderson was alone in the store two men entered and asked to be shown some diamond rings. A tray containing a large assortment was shown them, and, after critically examining them, they said they would look elsewhere before buying, and left the store. Before replacing the rings in the tray Mr.

Anderson was surprised at finding one ring missing, but in its place a worthless paste diamond. The police were notified, but as yet the men have not been apprehended.

### St. Louis.

Wm. F. Kemper is out again, after an illness of some weeks.

Sam. H. Bauman, of Bauman-Massa Jewelry Co., has returned from a business trip to New York.

Among out-of-town jewelers here last week were: G. W. Laterneau, Millstadt, Ill.; Fred Simon, Collinsville, Ill.; Jos. Knapp, of Knapp Bros., Belleville, Ill., and J. Bersche, Waterloo, Ill.

Albert Mauch, at the celebration of the 25th anniversary of the Concordia Turners, was presented with a handsome gold medallion, being an active Turner and charter member of the organization.

Miss Gertrude Heyman, mention of whose engagement was made in *THE CIRCULAR*, will sever her connection with Bauman-Massa Jewelry Co. on the 27th inst. She will be married to Ike Felsenthal, Galena, Kan., on Feb. 8.

At the office of Theo. Rassieur, in the Granite building, Jan. 15, the annual meeting of the stockholders of the Brooks Optical Co. was held, resulting in the reelection of A. R. Brooks, G. I. Brooks and Theo. Rassieur directors. The directors subsequently elected the following to serve in their respective capacities for another year: A. R. Brooks, president and treasurer; G. I. Brooks, secretary.

The store of August Winkler, 2550 St. Louis Ave., was entered by two men early last Monday evening, who asked an old man temporarily in charge to let them look at some jewelry. When his back was turned, one of them knocked him down, and the two men grabbed several trays of rings and watches and decamped. The loss will amount to several hundred dollars. A couple of arrests have been made.

### Indianapolis.

E. C. Miller is spending a few days at the mineral springs at West Baden, Ind.

Isaac C. Crane, 235 Virginia Ave., has canceled a real estate mortgage for \$700.

William T. Marcy sold a piece of residence property on N. Illinois St. last week for \$12,500.

Frank Johns has closed his repair shop in the Cardova building and taken a position with William T. Marcy.

George S. Drake, Pendleton, Ind., and

# The S.O. Bigney & Co.'s New Jewelry Plant.

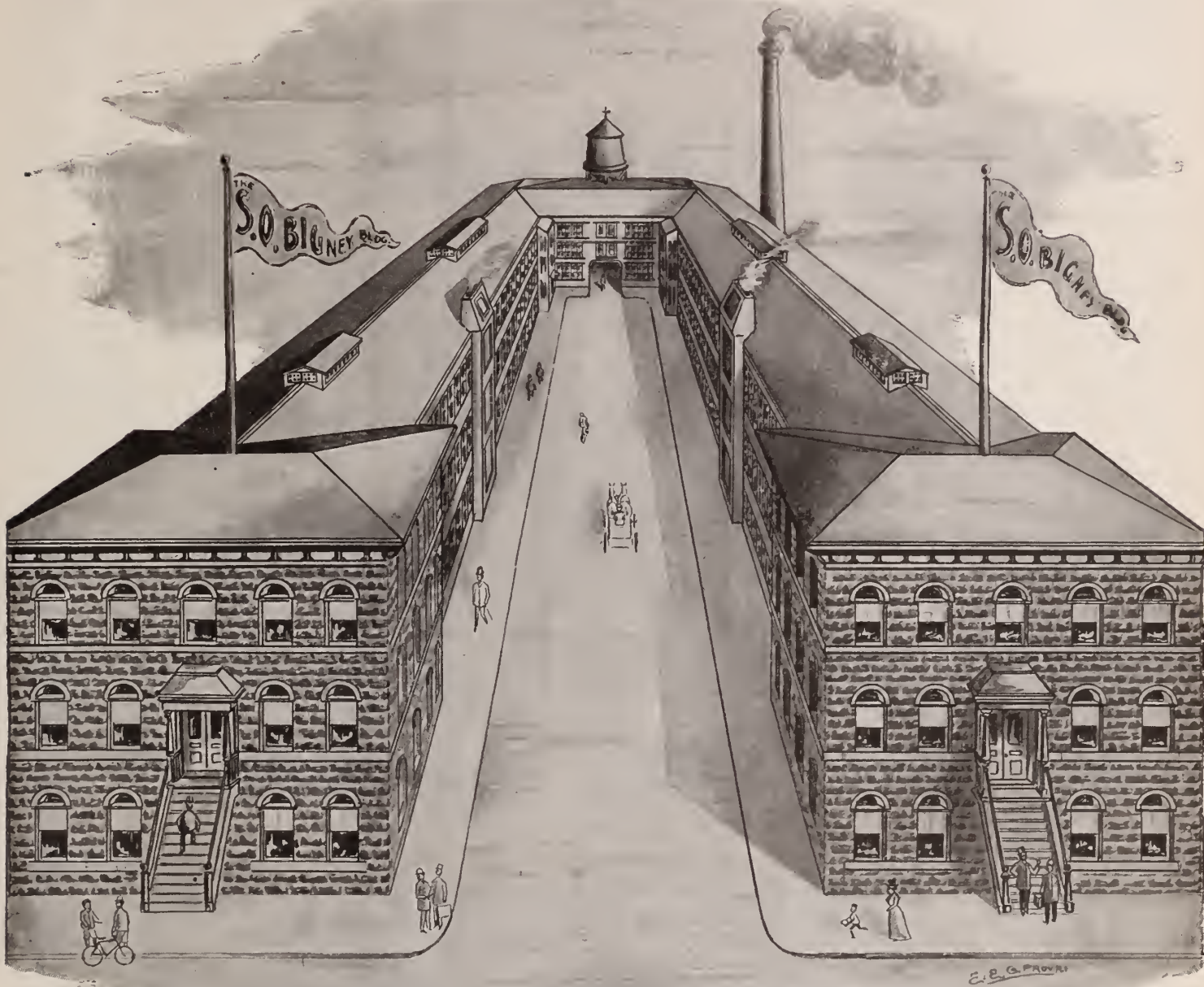

## TO THE JOBBING TRADE OF THE COUNTRY.

ATTLEBORO, MASS., Jan., 1900.

*Gentlemen:*—We take great pleasure in announcing that we are now located in our new plant at Attleboro, the largest and best equipped chain plant in the United States. We take this opportunity to thank the trade for their liberal patronage during the year 1899, which has had much to do in making our house one of the most successful in the jewelry industry. We shall ever strive to please and accommodate our customers in every way. "Promptness" will be our motto from this time forward, and we shall endeavor to ship all duplicate orders within twenty-four and not to exceed thirty-six hours after they reach our factory. Our large space and modern equipment will enable us to accomplish this. We have just one word to say to the retail trade: "Remember that no chain in the world stands higher and gives better satisfaction than our make, and that they are exactly as we represent them. We have three grades, ten, fifteen and twenty year, and every purchaser will get value received. Ask your jobber for these goods, for your stock will not be complete without them."



S. O. BIGNEY & CO., Attleboro, Mass.

Henry C. Rothinghouse. Gas City, Ind., passed through this city last week on their way to Florida.

The Ontario Silver Co., Muncie, Ind., are reported to be doing a good business this Spring and are advertising for more workmen.

The Columbia Jewelry Co., Louis Haas manager, have removed from 17 S. Meridian St. to the second floor in the "Big Four" block, corner of Meridian and Washington Sts.

Jobbers finished taking invoice last week and are now working on trunks, hoping to get their travelers on the road this week. Letters from all over Indiana and Illinois indicate that dealers are wanting goods.

Buyers in town last week included George L. Spahr, Lebanon, Ind.; George S. Drake, Pendleton, Ind.; A. W. Owen, Greenwood, Ind.; H. C. Rothinghouse, Gas City, Ind.; J. A. Meissen, Cicero, Ind.

The Stevenson building, 15 E. Washington St., is fast becoming a jewelers' center. The following firms are now located there: Third floor—Baldwin, Miller & Co., jobbers in watches, clocks and jewelry; S. T. Nichols & Co., jobbers in tools and material; A. P. Craft & Co., manufacturers. Fifth floor—Gross & Kaiser, jobbers in jewelry. Eighth floor, Heaton, Sims & Co., jobbers in jewelry. Tenth floor—Sims & Lauer, jobbers in jewelry; S. C. Thalls, watchmaker for the trade; Lou Chapman, engraver.

The creditors of W. H. Bradshaw, Wooster, O., have gained their point in having appointed a trustee, J. H. Johnston.

### Cincinnati.

B. W. Newman, of Frohman Co., has returned from the east after making a circuit of Providence, the Attleboros and New York.

On motion of the heirs of the late M. C. Motch, Covington, Mrs. Mary Motch, the mother of the heirs, was given power of attorney to manage and dispose of the estate.

Mr. and Mrs. Charles B. Eustis, Minneapolis, Minn., have been visiting relatives in Cincinnati. Mr. Eustis is a jeweler of Minneapolis and Mrs. Eustis is a daughter of the late Herman Duhme, founder of the old Duhme firm of Cincinnati.

Arthur B. Jonas, who was in the manufacturing jewelry and repair business in Cincinnati, but who lives in Covington, filed a petition in bankruptcy in the United States Court at Covington last week. His liabilities are placed at \$5,300 and his assets are two suits of clothes, valued at \$20.

S. Labusher, western representative of the O. E. Bell Co., starts on his Spring trip this week. He will stop a week at the Palmer house, in Chicago, and then continue his trip through the northwest to the Coast. He will carry a large line of the Bell cases and an elaborate stock of the new "Is-a-bell" guard chain.

The Duhme Jewelry Co. have filed an injunction suit against Auditor Lewis, to enjoin him from the collection of taxes on an addition of \$1,500 to the value of fixtures and \$49,500 to stock, made by the supervisors. The plaintiffs claim they have

not had a fair trial and that their representative, Herman Keck, was excluded from the room during the hearing last week; also that the supervisors have for 40 years not taxed a certain class above 50 per cent of its value and they claim the same pro rata reduction.

W. H. Clawson, Minocqua, Wis., who failed a fortnight ago, is trying to get a settlement from his creditors. His liabilities are placed at \$9,000 and his assets at \$6,000. A representative from a Chicago firm has been to Minocqua trying to have a meeting of the creditors so that a trustee could be appointed to protect their interests and not allow Clawson to go into bankruptcy. Clawson had been slow pay, but his creditors had no idea of his weakness. He had no creditors in Cincinnati, as far as can be learned. The O. E. Bell Co. sold to him in December, but got a settlement.

The loss entailed on jeweler S. B. Duncan, whose place in the Arcade was entered by unknown thieves recently, has just been made known. In addition to stuff taken from the L. F. E. Hummel jewelry store, adjoining Duncan's, the men got \$2,700 worth of diamonds. The stones were in a leather case in Duncan's safe, which was never locked. The theft of the diamonds probably explains the reason for the thieves leaving behind them many things taken from cases and then left in the store. It is probable that the men, coming suddenly upon the jewels, took them and escaped. The loss has caused Mr. Duncan to go out of business. He will give up his place about Feb. 1, to take a position as salesman for a local firm.

1850

# "BELL-POST" BUTTONS

1900

WILL NOT BEND OR BREAK.

PATENTED JANUARY 2d, 1900.

A NEW LINE  
FOR  
A NEW YEAR.

EVERY BUTTON  
GUARANTEED.

A GUARANTEE  
BACKED BY  
50 YEARS OF  
SUCCESS.



SOLID GOLD  
BUTTONS  
AT POPULAR  
PRICES.

EVERY PATTERN  
A  
WORK OF ART.

FINISH AND  
WORKMANSHIP  
UP-TO-DATE.

QUICK SELLERS—RELIABLE GOODS.

## JOHN T. MAURAN MFG. CO.,

New York Office:

Makers of Gold Jewelry.

Factory:

3 MAIDEN LANE.

PROVIDENCE, R. I.

Phoenix, Arizona.  
**Goldsmith Bros.**  
 Gentlemen :—Your check for old gold received this morning. Same is perfectly satisfactory. Please accept thanks for promptness. Yours respectfully,  
 Dr. GEO. B. PRATT, Optician.

Belvidere, Ills.  
 Messrs. Goldsmith Bros.  
 Dear Sirs :—Your letter and check received. You have sent me more than I had expected for the cases.  
 Respectfully yours,  
 A. VOGELI.

Pueblo, Colo.  
**Goldsmith Bros.**  
 Gentlemen :—Just in receipt of \$13.40 for old gold, which is more by \$6.00 than I figured it as worth; hence well satisfied. Thanks.  
 A. B. ALLEN, Jeweler.

Belding, Mich.  
 Dear Sirs :—Your estimate came; also check. I am perfectly satisfied. I have sent you gold for years and you have done better by me than any other firm.  
 Thanking you again, I remain,  
 Yours truly,  
 WILL H. RICABY.

Eureka, Utah.  
 Gents :—Am in receipt of your check for \$11.96 for old gold I sent you; the same is very satisfactory—in fact, better than I had expected.  
 Yours truly,  
 M. B. PARKS.

Rockwell City, Iowa.  
 Gentlemen :—Draft for \$13.39 for old gold and silver received this A. M., and beg to say I am more than pleased with the returns. This is the first I had sent you people, and when your letter came, my clerk and I guessed on the amount before opening envelope. \$5.00 and \$7.00 were our marks.  
 You shall have all my old gold and silver hereafter.  
 Yours truly,  
 J. R. LUCAS.

Ellsworth, Kans.  
 Messrs. Goldsmith Bros.  
 Gentlemen :—I have just received your draft for \$15.15 for gold, silver and plated scraps, and am well pleased, for, as usual, it is more than I expected, as I had figured about \$12.  
 Accept thanks for prompt attention.  
 Yours respectfully,  
 FRED A. KESLERT.

Pierre, S. Dak.  
**Goldsmith Bros.**  
 Gentlemen :—Your draft for \$18.36 arrived this A. M. I am more than satisfied. You shall have all of my old gold in the future. This shipment brought more than I expected.  
 Thanking you for draft, I am  
 Yours truly,  
 W. D. NELSON.

Eufaula, Ala.  
 Gentlemen :—Your check for \$7.46 for old gold and silver is entirely satisfactory—in fact it was more than I expected to get.  
 Yours truly,  
 J. B. SHELBY.

# Only This!

WE could easily fill an entire edition of THE CIRCULAR with the kind remarks of our customers—those who know from personal experience what our business methods are.

To those who have not yet sent us a consignment of sweeps or old gold or silver, we quote a few of our methods: Returns made on sweepings within 3 to 5 days of receipt. For old gold and silver we send you a check at once. If our valuation isn't satisfactory in every respect, send back the check and we'll return your shipment without cost to you.

## PRICES WE PAY.

**OLD SILVER,**  
 Platinum, 50 cts. per oz.  
 75 " " dwt.  
**OLD GOLD,**  
 8 karat, 32 cts. per dwt.  
 10 karat, 40 cts. per dwt.  
 12 karat, 48 cts. per dwt.  
 14 karat, 56 cts. per dwt.  
 18 karat, 72 cts. per dwt.  
**PLATED SCRAPS,**  
 20 to 35 cts. per oz.

HIGHEST  
 PRICES  
 ALWAYS.  
 \* \* \*  
 PROMPT  
 RETURNS.

# GOLDSMITH BROS.,

Sweep Smelters, Refiners and Assayers,  
 63-65 Washington Street, Chicago.  
 Works: 5826 Throop Street.

Reading, Pa.  
**Goldsmith Bros.**  
 Gentlemen :—Check for old gold and silver received. Beyond expectations! Will not forget you after this.  
 Thanking you for check I remain,  
 Yours,  
 GEO. H. FREES, Jeweler,  
 714 N. 10th St.

Oakland, Md.  
 Gents :—Check for old gold received; perfectly satisfied. I get better returns from you than anywhere else in the United States. I am speaking from experience. I am  
 Most truly yours,  
 F. G. HYDE.

Wellington, Kan.  
 Gentlemen :—Yours with check, \$55.15, old gold, silver, etc., received, and is satisfactory. Your remittance came within a few cents of our estimate. We do not hesitate to send you shipments, for we have learned that the place to get proper returns is Goldsmith Bros.' We thank you, gentlemen; you certainly are building a reputation for correct returns.  
 Very truly,  
 ROSER & Co.

Minneapolis, Minn.  
**Goldsmith Bros.**  
 Dear Sirs :—Acknowledge receipt of check for \$24.90, as payment for old gold. Thanking you for your HONEST estimations and prompt returns, we remain,  
 Yours very truly,  
 CHAS. OLSON & Co.

Butte, Mont.  
 Messrs. Goldsmith Bros.  
 Dear Sirs :—Yours of 20th, enclosing check for \$42.00, payment for old gold sent, received. The amount is very satisfactory. Kindly accept our thanks for same and also for prompt report.  
 Resp. yours,  
 LEYS & Co.

Lexington, Va.  
 Dear Sirs :—Your letter and check for gold and silver, amounting to \$63.40, received, and in reply will say that I accept same with thanks.  
 Very truly yours,  
 M. J. HESS.  
 W.

Minneapolis, Minn.  
**Goldsmith Bros.**  
 Gentlemen :—Your favor of the 15th inst. at hand with check enclosed. Same is entirely satisfactory to us.  
 Respectfully yours,  
 H. BIRKENHAUER & Co.

**Detroit.**

**TRADE CONDITIONS.**

Detroit jewelers say that trade since the holidays has been brisk, especially in diamonds and silver ware. The large downtown store proprietors will commence taking inventory the first of next month.

J. A. Selling & Co., jewelry jobbers, have removed to new quarters at 125 Jefferson Ave.

A woman sneak thief entered the jewelry store of J. P. Losey, Alma, Mich., and asked for some jewelry. Later a valuable diamond ring was missed.

Caroline Tuke claims she left a diamond ring with Roehm & Son for repair and that while it was in their possession the stone was changed for an inferior gem. She brings suit for the recovery of the value of the so-claimed original stone. Roehm & Son emphatically deny the allegation.

Charles Norman, a laborer, was arrested by the police here last week on suspicion. He had a valise which contained a lot of jewelry and silver ware. Later the stuff was identified as part of the booty secured by burglars at Tecumseh, Ont., where the jewelry store of Albert Jenisse was looted on the Saturday night before New Year's. Some of the jewelry was also stolen from a store at Woodstock, Ont. Detroit police say that Norman has served two terms in Jackson prison.

**Minneapolis and St. Paul.**

Out-of-town jewelers visiting the Twin Cities on business recently were: O.

M. Varnson, Cooperstown, N. D.; F. H. Towne, Sisseton, S. D.; W. G. Gould, Glencoe, Minn.

A. B. Faggerstrom, formerly with M. L. Cohen, Minneapolis, is now watchmaker for A. H. Simon, St. Paul.

Jake Cohen, St. Paul, has secured quarters in the Manhattan block, seventh floor, and will open up in the wholesale tool and material business. Mr. Cohen has gone east to purchase stock.

Albert Shipera, St. Paul, has rented an office in the Manhattan building, and will embark in the wholesale business there. The new firm contemplates handling cases, movements and jewelry.

L. Finkelstein, St. Paul, has leased new quarters in the Ryan Annex block, corner Robert and 7th Sts., on the second floor, which are now being remodeled and fitted up in fine style. Mr. Finkelstein expects to move into his new place some time before Feb. 1.

Holiday trade in the Twin Cities among the retailers was better than ever before. Jobbers were pleased with the results. Business is very active at present. Stock taking is the order of the day. Traveling men are preparing for the season's business, and before Feb. 1 all will be out on their routes again.

W. F. Cooper & Bro., Bristol, Tenn., were somewhat affected by a fire in that place a few days ago.

W. M. McConahay, Salt Lake City, Utah, has gone east on business and a short visit at his Ohio home.

**Columbus, O.**

David Cole, pawnbroker, Newark, O., was arrested a few days ago, on the charge of refusing to show goods on demand of the officers.

It is said that another retail jewelry store will be opened in this city in a short time. At present the names of the persons backing the new enterprise cannot be given.

The traveling men passing through here say that the trade is very much easier than it was last year at this time. Sales are more easily made. They think the Spring trade will be better than it has been in years.

The wound in Charles Klee's neck, made in an attempted hold-up some days ago, has proven more serious than was expected. Being in the muscles of the neck it is very painful and difficult to heal. His brother, Otto, is getting along nicely.

Benjamin J. Franklin, jeweler, Mahanoy City, Pa., who died last week, was born and reared in this city. He learned his trade with F. F. Bonnet and went into business for himself in the Spring of 1893. His father, John Franklin, still resides in this city.

Andrew Morden, who has been connected with various establishments in this city, will within a short time open a jewelry store in the room on High St. now occupied by the Big Four city ticket office and the Postal Telegraph Co. The room will be overhauled and put in splendid condition.

Alex. W. Krumm has published a notice that he has been appointed by the Court of Common Pleas of Franklin county, Ohio, as receiver (successor) of the Columbus Watch Co. (old company), and that all creditors and debtors of said company and of the receiver thereof are required to make settlement with him as such receiver.

F. R. Cross & Co. are now in the second quarter of the watch inspection on the Norfolk and Western. They state that a number of the men have purchased new watches and all are getting a much higher standard of movement than they have ever before used. This was one of the prime motives of the company in having a thorough inspection made some time ago, but it was necessary to give them some time to make the change.

I. G. Dillon, of Dillon, Hancher & Co., Wheeling, W. Va., passed through this city Thursday with the remains of his wife, who died at Asheville, N. C., last Wednesday morning, from lung trouble. She had gone there in the hope of regaining her health, but received no benefit from the warm climate of the south. The funeral took place at Wheeling, Friday. Mrs. Dillon was a sister of Mrs. F. B. Ross, of this city. Mr. and Mrs. Ross attended the funeral and remained a few days with the family.

Christian M. Wendelboe, Logan, Utah, has filed a bankruptcy petition. Liabilities, \$3,625; assets, \$2,980.

Mrs. W. P. Brandenburg, jeweler, 42 years of age, of Louisville, Ky., died a few days ago.



**MY! BUT WASN'T SHE A CORKER.  
COULDN'T BEGIN TO FILL ALL THE ORDERS.**  
We worked a night and day force for a month.  
We were compelled to enlarge our factory and sales-room three times during the past year.  
That shows how **Good, Honest, Up-to-Date, Quick-Selling Merchandise at Popular Prices** is appreciated.

For the coming Spring we have made up the **Largest and Most Complete Line of Seasonable, Up-to-Date Novelties** ever shown.

Wait for "Our Imperial Salesman" before placing your orders.

We want to show you how you can make **One-third More Profit** on what you sell.

**IMPERIAL MFG. CO.,**

MASONIC TEMPLE,

CHICAGO.

**Georgian** STERLING SILVER.

In Complete Table Service—

French Gray Finish.



COFFEE SPOON.

**TOWLE** MANUFACTURING CO.,  
CHICAGO.

NEWBURYPORT, MASS.



### News Gleanings.

Mayor Roche, of Cuero, Tex., has opened a jewelry stock.

Lee Edwards has removed from Ridge-way, Va., to Spray, N. C.

C. L. Cooke, Clarksville, Tenn., has removed to improved quarters.

J. Okerstrom, Cambridge, Ill., has sold his stock to Seth H. Clay, another jeweler.

Lee Thompson, of Monument City, Ind., will open a jewelry store in Andrews, Ind.

Gus F. Bauch, of Ft. Madison, Ia., will engage in the jewelry business in Vicksburg, Miss.

George H. Taylor, New Rochelle, N. Y., has taken possession of his new store on Main St.

E. Ferris, Mount Morris, N. Y., has been appointed watch inspector of the D. L. & W. Ry.

C. G. Sheldon, Exeter, N. H., will soon remove his jewelry business to the new post office block.

M. Dreyfus, for a number of years a jeweler of Okolona, Miss., was stricken with paralysis Jan. 13.

In a fire in Osakis, Minn., a few days ago, William Lenz's jewelry store was among the places affected.

George J. Boyden, jeweler, Bay City, Mich., has purchased a place on Broadway, near 32d St., that city.

V. W. Brown opened a new jewelry store Jan. 13 in part of the millinery store known as "The Elsie," Haverhill, Mass.

A few nights ago someone broke into the store of J. H. Payne & Son, Holland, Tex., and took about \$100 worth of watches and jewelry.

Clay Henry, who for many years conducted a jewelry store in Ironton, O., is now a traveling salesman for the Keystone Watch Case Co.

Frank Eltzroth, from La Fayette, Ill., has moved into the jewelry store recently occupied by J. K. Okerstrom, Cambridge, Ill., and will do repairing.

G. D. Ralston, engaged in the jewelry business in Portland, Mich., has decided to give up farming and will sell at auction his stock and farm tools.

Solomon E. Smith, president of the J. W. Smith Dry Goods Co., Geneva, N. Y., died last week. He was a director of the Standard Optical Co., of Geneva.

Herman Kramer, who has been working in a jewelry store in Dubuque, Ia., for some time past, has left for Worthington, where he will open up a jewelry store.

E. J. Steuerwald, Redwood Falls, Minn., has disposed of his stock to John Rosendahl, of Echo, and will soon start as a commercial traveler for an eastern jewelry house.

Frank Barta, the 10-year-old boy recently arrested for the theft of two watches valued at \$10 and \$12, at A. Seidensticker's jewelry store, Hamilton, O., will be taken to the reform school at Lancaster.

Lansing Tontine Security Co., Lansing, Mich., have incorporated to do a jewelry business. Capital, \$5,000. Incorporators: F. S. Porter, R. Smith, of Lansing; W. W. Terrill, of Portland; V. Brown, T. B. Waring, both of Ionia.

George Cook, jeweler, and William Roche, electrician, of Madison, S. D., have jointly perfected an electric alarm clock. The alarm attachment is operated by a small liquid cell battery, and at the appointed hour begins to ring and continues till some one switches off the current.

C. T. Dunn, who was arrested in Roswell, N. M., a few days ago, charged with being an accessory to the robbery of the Frank Fix jewelry store last New Year's night, when \$300 worth of watches and rings were taken, was subsequently discharged, no evidence being found against him.

Jan. 11 a petition was filed in the Federal Court, at Dallas, Tex., by D. C. Butz and I. M. Standifer, of Denison, Heintz Bros., Buffalo, N. Y., the S. A. Rider

Jewelry Co., St. Louis, Henry Freund & Bro., New York, and E. A. Cowan & Co., Boston, Mass., praying that H. E. Knowles, of Denison, be adjudged an involuntary bankrupt and alleging the petitioners are creditors of the said Knowles.

Hugo Fischer, for many years a resident of Lynchburg, Va., died recently at his home in Salem, after only three or four days' illness from pneumonia. Mr. Fischer was 61 years of age and was born in Germany. He was a jeweler by trade, and worked a number of years in New York, and was in Lynchburg in the employ of H. Silverthorn for six or seven years, and from 1892 to 1898 worked for Ryland & Rankin. After that he retired to his home at Salem, where he owned considerable property.

WE desire to call the attention of those buying early this season to our large and complete line of guard chains suitable for the lorgnette, watch, fan, muff, purse, or for use as an eye-glass chain, and especially to the many new patterns of chains and slides we are showing. We have borne in mind the tendency toward heavier chains, and are showing some patterns which at this date we believe cannot be duplicated elsewhere.

B. A. BALLOU & CO.,  
Providence, R. I.

## A NEW METHOD

IN MAKING

### Travelers' Watch and Ring Trays

ENABLES US TO PRODUCE THE

STRONGEST TRAY EVER MADE.

Guaranteed for One Year.

FOR FULL INFORMATION, WRITE OR CALL.

S. VALFER & CO.,

Manufacturers of FINE CASES AND TRAYS for Jewelry and Silverware,

33 MAIDEN LANE, NEW YORK.

CONSULT

"The New York Jeweler"

Before Buying Jewelry or Kindred Lines.

For 26 years the acknowledged authority for all that is new, artistic and beautiful in the Jewelry World.



724 Pages. Size, 9x13.

This profusely illustrated catalogue enables the dealer to make a better selection than the majority of travelers' stocks affords.

S. F. MYERS CO.,

MANUFACTURING and WHOLESALE JEWELERS

Myers Building, 48-50 Maiden Lane, New York.

Mention Dept. G 12 when sending for catalogue.

Survival of the Fittest.

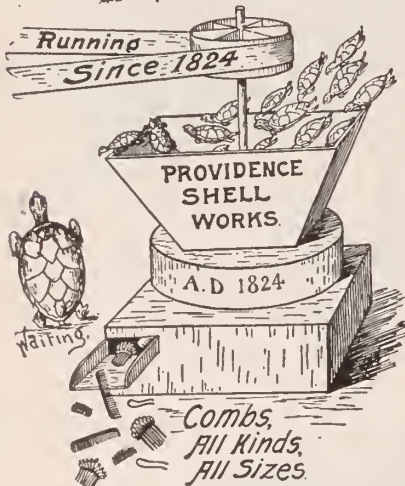

POTTER'S COMB FACTORY,  
PROVIDENCE, R.I.

We Grind for You,  
Send along your Work.

W. C. A. WESTPHAL,

WATCHMAKER,

41 Maiden Lane, NEW YORK.

Established 1892. Telephone, 3684 Cortlandt.

Estimates, Repairing, Adjusting of Chronometers, all Complicated Watches and Fine Time Pieces.

DEMAGNETIZING.

Watches made Non-Magnetic.

Fine Wheel and Pinion Cutting

W. A. Nelson, Wapello, Ia., has given a bill of sale for \$100.

E. W. Mitchell is closing out his stock of jewelry in Waco, Tex.

L. B. Moore, Sac City, Ia., has given a chattel mortgage for \$230.

William Eberle has sold out his stock of jewelry in Mapleton, Ia.

Jeweler Mester, St. Joseph, Mo., is now located at 420 Commercial St.

C. F. Richards, Seattle, Wash., has paid off a chattel mortgage for \$3,500.

M. Hulshouser will remove his stock of jewelry away from Lohrville, Ia.

George H. Person has opened a repair shop at 610 Mauch Chunk St., Easton, Pa.

A. Eisler, jeweler and druggist, Harper, Kan., has given a realty mortgage for \$500.

Crandall & Consigny, Emmetsburg, Ia., have paid off a realty mortgage for \$2,300.

R. G. Colvin, jeweler, Hastings, Neb., has given a chattel mortgage on stock for \$1,286.

Theo. Stuedel, jeweler, Chilton, Wis., proposes to erect a new building in the Spring.

W. M. Crutchet, watchmaker, Carrington, N. D., has sustained a considerable fire loss.

A. L. Kilby has removed his entire stock of jewelry from Ottumwa to Sanborn, Ia.

J. E. Gustason, McPherson, Kan., recently opened a branch store in Lindsburg, Kan.

Mrs. J. Karatofsky will discontinue her pawnbroking and jewelry business in Helena, Mont.

A. B. Corman, formerly located in Pana, Ill., has opened a stock of jewelry in Perry, Okla.

The W. Samuel Loan Co., a jewelry and pawnbroking firm of Dallas, Tex., have been sued for \$118.

W. F. Wilharm has given a bill of sale on his interest in the business of Wilharm Bros., Tripoli, Ia.

Charles A. Fisher, jewelry and notion dealer, Ottumwa, Ia., has filed a petition in the bankruptcy court.

Barber & Richardson, Fullerton, Neb., have dissolved, and Mr. Richardson will continue the business alone.

G. N. Hadley, Bedford, Ia., has given a chattel mortgage for \$1,500 on horses and a realty mortgage for \$1,500.

H. E. Knowles, formerly engaged in the jewelry business in Denison, Tex., has gone into involuntary bankruptcy.

Mrs. A. O. Berg, engaged in the jewel-

ry business in Graettinger, Ia., has given a realty conveyance amounting to \$1,200.

W. H. Wright, Webb City, Mo., has moved into his new brick building, which was made by him especially for his jewelry store.

Frank L. Brown, Wilkes-Barre, Pa., has been appointed watch inspector for the Bloomsburg division of the D., L. & W. R. R. Co.

Mrs. Cornelia Hofma, wife of Lawrence Hofma, jeweler, 162 Ellsworth Ave., Grand Rapids, Mich., committed suicide recently by taking arsenic.

S. Martin, jewelers' auctioneer, has begun a sale of the J. P. Foss jewelry stock, Wausau, Wis. Mr. Foss announces that he is going out of the jewelry business.

W. P. Heichert & Co., a jewelry firm of Howard, Kan., have greatly extended their book department, and now have one of the most attractive stores in the city.

R. J. Stevens has purchased the jewelry business of Harvey Horner, Caldwell, Kan., and will retain the services of Frank Kilgore, the watchmaker of the old firm.

The New Haven Silver Plate Co., Lyons, N. Y., have ceased to exist as a stock company, O. F. Thomas having withdrawn. The business will be continued by George W. Banks, who has been president.

Burglars early on the morning of Jan. 16 cut with a diamond a hole in the store window of Charles Rothstein, jeweler, Bradford, Pa., and took everything in sight. The store is located in the heart of Main St., and was brilliantly illuminated when the robbery took place.

Philip Weiss, a shoemaker, and Israel Reiner, a jeweler, Phoenixville, Pa., appeared before Justice Howell a few days ago in a civil action brought by the former against the latter. Weiss brought suit against Reiner for \$3, claiming that the jeweler owed him that amount for dressing his window for the holidays.

An order compelling all persons interested in the Co-operative Silver Co., Corfu, N. Y., to show cause why the corporation should not be dissolved was granted by Justice Kruse in the special term of the Supreme Court at Buffalo, N. Y., Jan. 16. The application for the order of dissolution was made by Asa K. Darrow, A. Kenyon Maynard and John Lincoln, a majority of the directors, who alleged in their papers that William N. and Charles H. Fessenden, of Niagara Falls, promoters of the company, had not lived up to their promises and agreements. The order was made returnable on April 20, before attorney Frank S. Wood, of Batavia.

We have made a speciality of

FINE FINGER RINGS

for more than half a century.

GEO. O. STREET & SONS,

24 JOHN ST., NEW YORK.

... Established 1837 ...







**THE MAUSER MFG. COMPANY,**  
SILVERSMITHS,

"Watch Our Ads." 15th St., bet. Broadway and Fifth Ave., New York.



Heart Bangles, Sterling Silver, 925-1000 Fine.  
Our specialty in Hearts is a line of Sterling Silver Souvenir Bangles with names, initials and mottoes on one side. Our price for these goods ranges from \$10.50 per gross to \$22.50 per gross. Hearts same as those illustrated herewith, with the following mottoes: Remember Me, Forget-Me-Not, Friendship, Best Wishes, Darling and Baby, in die work, at \$10.50 per gross, plain bead and two other fancy scroll patterns, \$10.50 per gross. Bead pattern, with name of any town etched by hand on one side, \$16.50 per gross. Terms net cash, 10 days, f. o. b. factory.  
**SIMMONS & PAYE,** "The Souvenir House,"  
129 Eddy St. Providence R. I.

**WOOD & HUGHES,**  
Sterling Silverware Manufacturers,  
FINE PLATED WARE,  
No. 24 John Street, - New York.

**H. M. RICH & CO.,**  
Jewelry - Auctioneers,  
7 and 9 Franklin St.,  
BOSTON, MASS.

**JACOT & SON, IMPORTERS.**  
**STELLA AND IDEAL**  
**MUSIC BOXES.**  
89 UNION SQUARE, - N. Y.

**THE LEDOS MFG. CO.,**  
MANUFACTURERS OF  
Watch Case Materials,  
Crowns, Pendants, Bows, Solders,  
Springs, Findings, Etc.,  
34-36 PEARL ST., NEWARK, N. J.

**THE BASSETT JEWELRY CO.,**  
Fine Gold-Filled Chains,  
Locketts and Gold Jewelry,  
PROVIDENCE, R. I.



144 PINE ST., PROVIDENCE, R. I.

**Plated Seamless Wire and Aluminum Solder.**

These well-known Razors, the quality of which is warranted, possess this great advantage, that they may be used for ten years before they require actual sharpening. Before using them it is necessary to rub them on good leather strop. Le Coultre's Strops (to be had with the Razors) should be used in preference to others.



THIS CUT IS TWO-THIRDS OF REGULAR SIZE.

"SPECIAL"—Single Razors for Jewelers' Travelers at trade price.

**MATHEY BROS., MATHEZ & CO.**  
Send for Price List. Sole Agents, 21 & 23 MAIDEN LANE, N. Y.

Established 1879. Manufacturer of  
**LOUIS W. HRABA,** Fine Leather Goods  
29 East 19th St., New York. Exclusively for the Jewelry Trade.



GOLD SHELL.

"Buy direct from the manufacturer and get all that is coming to you."  
SEND FOR OUR "HOT CATALOGUE, CONTAINING GOLD FACTS AND PRETTY PICTURES."  
**CLARK & COOMBS,**  
86 WEST EXCHANGE ST., PROVIDENCE, R. I.

WE ARE HEADQUARTERS FOR.....  
**Gold Shell Rings...**

**Did You Read** our offer in the last issue of THE CIRCULAR of **\$100.00 in Gold** as a Prize for the best sample of engraving done on our engraving machine?  
**The Eaton & Glover Company,**  
87 NASSAU STREET, NEW YORK.

**ESSER & BARRY,** Largest Manufacturers of Cheap and Medium Priced IMITATION DIAMOND JEWELRY IN AMERICA.  
Write us for samples of almost anything with an Imitation Diamond in it.  
MAIN OFFICE AND FACTORY, 101 SABIN ST., PROVIDENCE, R. I.

**WATCH CASE GUARANTEES.**

THE RETAIL JEWELERS SPEAK OUT AND GIVE THEIR IDEAS ON AN IMPORTANT MATTER BEARING UPON THEIR TRADE.

[This series of letters began in issue of Nov. 15.]

It was upon the request of several responsible jewelers that THE CIRCULAR entered upon the undertaking of obtaining a consensus of opinion from the retail trade regarding the guaranteeing of gold filled watch cases, and sent to a large number of jewelers, indiscriminately, a letter of which the following is a copy:

NEW YORK, Sept. 8, 1899.

WE ARE SENDING THIS LETTER TO THE RETAIL TRADE WITH THE OBJECT OF GETTING THEIR VIEWS ON AN IMPORTANT SUBJECT, NAMELY: THE GUARANTEEING OF FILLED WATCH CASES. FROM THE RESPONSES RECEIVED MAY BE EVOLVED SOME VALUABLE SUGGESTIONS.

OF THE FOLLOWING FORMS OF GUARANTEE, WHICH DO YOU CONSIDER MOST JUST, AND WHAT ARE YOUR ARGUMENTS ON THE SUBJECT?

1. SHOULD THE MANUFACTURER GIVE A NEW CASE OF THE SAME GUARANTEE IN EXCHANGE FOR THE OLD CASE THAT HAS NOT LIVED UP TO ITS GUARANTEE?

2. SHOULD THE MANUFACTURER EXCHANGE THE CASE THAT HAS NOT LIVED UP TO ITS GUARANTEE WITH ONE OF LOWER GUARANTEE? THAT IS, IF A 20-YEAR CASE HAS BECOME DEFECTIVE AT THE END OF 10 YEARS, SHOULD IT BE REPLACED WITH A 10-YEAR CASE?

3. SHOULD THE MANUFACTURER REPAIR THE CASE AND PUT IT IN CONDITION TO OUTLIVE THE UNEXPIRED TERM, IF THE CASE SHOWS THE BASE

METAL BEFORE THE LIFE OF THE GUARANTEE HAS EXPIRED?

4. SHOULD HE GIVE A NEW CASE AND CHARGE FOR THE LENGTH OF TIME THE CASE THAT DID NOT LIVE UP TO ITS GUARANTEE HAS BEEN WORN; IN OTHER WORDS, REBATE FOR THE UNEXPIRED TERM OF GUARANTEE?

YOURS VERY TRULY,  
THE JEWELERS' CIRCULAR PUB. CO.

All those jewelers who did not receive this letter are cordially invited to send their views upon this subject, replying to the questions seriatim or collectively. Their replies will receive the same measure of consideration as those received direct from the letters themselves. The more views on this subject expressed by the trade at large the more convincing will be the conclusions reached.

[Eleventh series of replies.]

GRINNELL, Ia., Jan. 11, 1900.

Editor of THE JEWELERS' CIRCULAR:

In answer to your question, should the manufacturer replace worn-out filled cases with cases of same value to fill out the unexpired time, I answer yes; it is a guarantee of good faith and insures the sale of another of same make if another gold filled case is wanted in the same family. I have had this experience.

2. It would destroy confidence in the gold filled cases; the owner has paid for a good case, and is entitled to a case of same quality.

3. It is impossible to repair a case to fill out the unexpired time and the owner feels the dealer is trying to avoid replacing with a new one.

4. This cannot in my opinion be done satisfactorily, as many are not willing to pay the express both ways to make the exchange. I would suggest more gold and better price, but not better price without the gold, and no increase in the guarantee. The small percentage of gold used in most of the filled cases makes it impossible to wear the length of the guarantee.  
E. A. MARSH.

CARTHAGE, Ill., Sept. 18, 1899.

Editor of THE JEWELERS' CIRCULAR:

Your circular letter received, issued for the purpose of feeling the pulse of the retail trade relative to the guaranteeing of gold filled watch cases.

I am decidedly in favor of the manufacturer fulfilling the guarantee which he places in his cases, either by trade-mark or by certificate, and when the case fails to perform the duty or purpose the manufacturer intended it should and with so much confidence and assurance on his part as to place a printed guarantee or plainly stamp the lease of life he had given on his productions, he should with pleasure take back the old case which has not proven as he has represented, and issue to the retailer in exchange for it a new case of the same guarantee as the old or faulty one possessed, and do it as expeditiously as it is convenient for him to do so, not keeping the retailer waiting 30, 60 or 90 days, as is frequently done by some of the manufacturers to my personal knowledge. I firmly believe that is the only fair and just way of dealing with the question, and I believe the manufacturer that pursues such a course in trying to aid the trade in maintaining the reputation of his cases is the one that will eventually win. The trade will not be slow in finding it out, either, and will give his cases the full benefit of the little song which he sings daily over his showcases to the many prospective customers he has. The manufacturer makes the cases, knows to the grain how much gold they contain, the quality thereof, gives it a specific length of life, and puts his price upon it; thus far he has had matters all his own way, no one to interfere, and time, and time only, will tell if his productions will last the specific length of life he has given, or whether the accompanying guarantee is worth the paper it is printed on; or if the manufacturer is a man of his word, or if he wilfully robbed the jeweler's customer of that much money. The retailer buys the case from his jobber in good faith, as represented by the accompanying guarantee, and just as soon as an opportunity presents itself disposes of it to his trade. His customer makes no pretense of being a judge of such goods but relies solely upon the reputation of his jeweler, who, in turn, points to or reads with much self-reliance the certificate inside of the case, and the customer goes away happy, feeling that for once in his life he has got just what he has paid for, because the jeweler told him that it was a 14-karat case guaranteed for 20 years. Besides there was the manufacturer's guarantee stamped in the case; but, alas, he discovers after he has worn it a few years that time has not dealt with it so easily; so a little out of humor—some people would call it mad—he makes a special trip to see the jeweler he purchased it from, and etc., etc., etc.

Imagine the position of the jeweler who is working hard these times to support himself and family, pay his honest debts and is trying to maintain his reputation in the city he is doing business in when he would have to tell, perhaps his best friend or one of his best paying cus-

# BATES & BACON

Gold-Filled Watch Cases.

NONE BETTER.

ASK YOUR JOBBER FOR THEM.

## Our Hand-made Cases

are constructed in the old reliable way, which is a pride to the Manufacturer, Dealer and Wearer.

STAMPED.



18 K.

ALL CASES BEARING THIS MARK,  
ARE HAND-MADE.

STAMPED.



14 K.

Manufactured by

**DUBOIS WATCH CASE CO.,**

Makers of **SOLID GOLD CASES.**

21 and 23 Maiden Lane, New York.

tomers, that the guarantee was only placed in the case in order to help sell it, that there was no meaning to it, that the manufacturer was no good, etc., etc.; or say, "Yes, you leave your case and I will send it to the manufacturer and he will replate and repair the case so it will last the length of time he specified, or have the company send you instead a 10-karat case warranted for 15 years in exchange for the 14-karat 20-year case, or have them come back at you with a bill of repairs, like some of them have done me: 'Bowring in case you returned is not of our make, charges \$; case spring has been replaced with another, not of our make, charges \$; crystal out, charges \$; two tips lost out of the joint, charges \$; total, \$\$\$\$'. Please remit and we will send you in exchange another case.' Or come back at you easy with a certain form of an affidavit requesting you to go before a notary and have the blank space properly filled in and sworn to, return it to them, and they will send you a new case." Then when some representative of our jobbing houses comes around to sell you some gold filled cases would you, Mr. Jeweler, buy the case of the manufacturer who only half way fulfills his guarantee? If you do you deserve to lose your reputation in your city, and should hire some cheap boy to kick you clear out of the county you are trying to do business in. No, sir! You would buy the make of case where the manufacturer gladly returns you a new case with the same guarantee that the faulty one possessed that you sent into him, and wrote you a nice letter thanking you for the trouble and interest shown by sending the defective case to him, and you, with so much pride, hunted up your customer to whom the case belonged, and read the letter to him, then re-read and commented on it to the manufacturer's credit; then you feel it was a pleasure to live and try to sell gold filled cases of their make. Mr. Editor, I firmly believe the only way for a man to do business and to succeed at it is to give a customer just what he pays for, and should it not prove satisfactory try and make it satisfactory; then he can look each man, woman and child straight in the face as they meet daily and wish them well and not want to hide behind the counter when the customers come in the door, or go down a back street to avoid meeting them. "Yours for a square deal,"

L. W. BERRY.

MONMOUTH, Ill., Sept. 23, 1899.

Editor of THE JEWELERS' CIRCULAR:

In reply to your queries, would say manufacturers should give a case to fill out the time of guarantee.

2. Yes.
3. If it can be done, O. K.
4. No. Respectfully,  
E. I. CAMM.

SHELBYVILLE, Ind., Sept. 16, 1899.

Editor of THE JEWELERS' CIRCULAR:

In reply to your letter about guaranteeing of filled watch cases, I will say that I think that the manufacturers' warrant implies that they will give a new case of the same quality for every one that does not wear well or give satisfaction. And I think that the manufacturer that lives up to that guarantee will be the one that will get the business. A manufacturer cannot repair a case to live out an unexpired term of 10 or 12 years, and a customer would not be satisfied with a repaired case. Yours truly,

FRANK C. SHELDON.

(Series of letters to be continued.)

**Connecticut.**

Jeweler Goodwin, Milford, expects to sell out his business and remove to Torrington.

Two new buildings have been contracted for by the Waterbury Clock Co., Waterbury, as an addition to their factory.

Geo. C. Edwards, of the Holmes & Edwards Silver Co., has been elected a director of the Connecticut National bank, Bridgeport.

The National Self-Winding Clock Co. have engaged space in a factory on Oak St., Bristol, and a small force of men, are now at work.

The Meriden Bronze Co., Meriden, have suspended business. Jan. 15 a meeting of the creditors was held. The liabilities are \$311,578.63, and the assets \$263,974.

On Jan. 14 one of the drying boxes in the plating room of the E. Ingraham Co., Bristol, got afire in some unknown manner. The blaze was extinguished in short order.

Charles Parker, Walter Hubbard and G. M. Curtis are among those elected directors of the Meriden Trust and Safe Deposit Co., and Walter B. Hubbard was re-elected president. Col. W. J. Leavenworth has been re-elected president of the Wallingford National bank and one of the bank's auditors.

Jeweler Henry M. Mather and wife, Meriden, left on Jan. 14 for San Francisco, Cal., to be absent three or four months. The trip is taken in hopes of benefiting Mrs. Mather's health, which has been poor for 18 years. During Mr.

Mather's absence his jewelry business will be in charge of Fred Weber.

It is reported from San Francisco that George H. Wilcox, vice-president of the International Silver Co., Meriden, has met with a painful accident. The report is somewhat meagre, but it appears that Mr. Wilcox was thrown off an electric car, and that one of the rear wheels passed over his right arm, breaking it in two places and dislocating his right shoulder.

In relation to a report that one George D. Lamberton, of New London, had been visiting silver manufacturers in Meriden relative to starting a concern in that city, with Frank C. Munsey capital, to buck against the International Silver Co., Wilbur F. Rogers, of C. Rogers & Bros., says as far as his company are concerned no such man as Mr. Lamberton, or any one else answering the description, has visited C. Rogers & Bros. and proposed any such scheme.

Elected directors last week: George H. Wilcox and Charles Parker, of the Meriden National Bank; Edward Miller, Geo. M. Curtis, Walter B. Hubbard, Samuel Dodd and E. B. Cowles, of the Home Bank, Meriden; Cephas B. Rogers, N. L. Bradley and Chas. L. Rockwell, of the First National Bank, Meriden; Walter B. Hubbard, of the Middletown National Bank, of which he was elected president also; Col. W. J. Miller, of the Birmingham National Bank; Col. W. J. Leavenworth, F. A. Wallace, Henry Hull, Charles H. Tibbits, of the First National Bank, of Wallingford; L. A. Barbour, of the Charter Oak National Bank, Hartford.

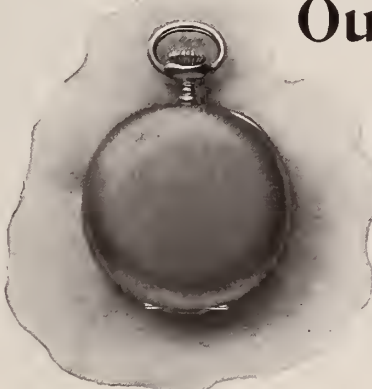

## Our New Jewel Case.





TRADE-MARK REGISTERED.

Pretty, well-made and catchy styles in gold watch cases will be sellers this year. We have succeeded in putting on the market for the Spring trade the best article that we have ever made.

## Roy Watch Case Co.,

NEW YORK.

**The Latest Patents.**

ISSUE OF JAN. 16, 1900.

- 641,454. MUSIC-BOX. KARL LANDA, Bayonne, N. J. Filed April 5, 1899. Serial No. 711,782. (No model.)
- 641,475. REPEATING CLOCK. ENRIQUE TORRES, Guadalajara, Mexico. Filed July 29, 1899. Serial No. 725,497. (No model.)

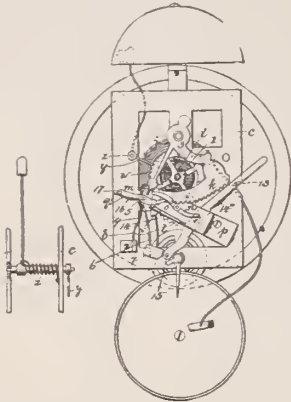

In a clock of the character herein described, the combination with a time mechanism and mainspring, of an independent striking mechanism, and an independent power-spring for said striking mechanism, said latter independent spring consisting of a coiled spring and a spring-band, one end of the coil secured to the band, a rivet connecting said spring and band, one end of said band bearing against said rivet, a drum within which said band and coil are placed, a central minute-hand arbor extending through said drum, one end of the coil secured to said arbor, the opposite end of the coil and the connected band adapted to slide within the drum as the coil is tightened by the rotation of said arbor.

- 641,476. REPEATING STRIKING MECHANISM FOR CLOCKS. ENRIQUE TORRES, Guadalajara, Mexico. Filed July 29, 1899. Serial No. 725,498. (No model.)

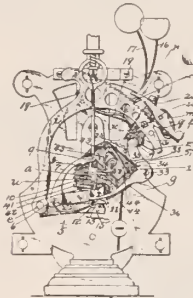

In a repeating clock, in combination with the time-train, means for repeating the hours at certain fractions thereof, a stop for preventing the operation of said repeating means, and a trip for said stop, carried by the time-train, whereby the hours are struck when indicated, but not repeated at the fractions thereof.

- 641,477. REPEATING CLOCK. ENRIQUE TORRES, Guadalajara, Mexico. Filed July 29, 1899. Serial No. 725,499. (No model.)

**CROWN CASES**

FOR SALE BY

**ALL JOBBERS.**

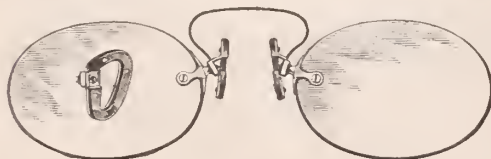

Successors to Levy, Dreyfus & Co. 194 Broadway, New York.

In a clock, in combination with a movable dial, a ratchet-wheel carried thereby, a rocking ratchet-lever, a time-train, a wheel released by said train;

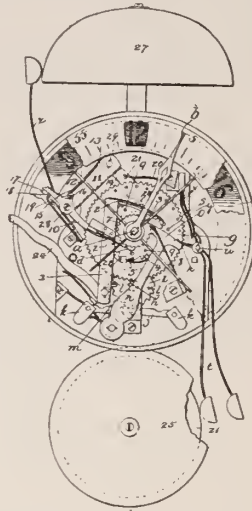

means to drive the wheel, and a trip on said wheel to rock said lever.

- 641,478. REPEATING WATCH. ENRIQUE TORRES, Guadalajara, Mexico. Filed July 29, 1899. Serial No. 725,500. (No model.)

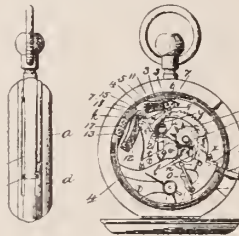

In a repeating time-piece, in combination with a bell and a hammer, a hammer-vibrating member, an operating handle-lever directly and integrally attached to said member to move it, and a pawl connection between said vibrating member and hammer to enable said vibrating member to move freely past the hammer when pushed in one direction by the handle and to vibrate the hammer when the handle is pulled back, whereby the vibrating member is positively positioned for vibrating the hammer and positively pulled back to vibrate the hammer, by said handle-lever.

- 641,503. FOUNTAIN-PEN-FILLING DEVICE. LYMAN FISK, Hackensack, N. J., assignor of one-half to Edward L. Beekman, same place. Filed June 14, 1899. Serial No. 720,496. (No model.)

- 641,505. COLLAR-BUTTON. EDWARD H. WHEELER, Waterbury, Conn. Filed March 28, 1899. Serial No. 710,764. (No model.)



The combination in a collar-button, of a base having a hollow oblong post with an open top and tubular enlargement, a U-shaped laterally-yieldable shank slidably mounted in said post, a spring within the post and enlargement to normally hold said shank in a retracted position, a head pivoted between the free ends of said shank and adapted to be seated within the open end of said post when extended, and to rest thereon at a right angle when locked.

ORDER A SAMPLE

**GOLF EYEGLASS FRAME,**  
Nickel Plate. For 1 Eye Lenses, 30c.

**IMPERIAL PERISCOPE Cx,**  
1 Eye Lenses, \$1.00 doz pair.

**L. W. LEVY & CO.,**

194 Broadway, New York.

- 641,540. GEOGRAPHICAL CLOCK. ISAAC F. PHELPS, Woodville, O. Filed Sept. 29, 1898. Serial No. 692,229. (No model.)

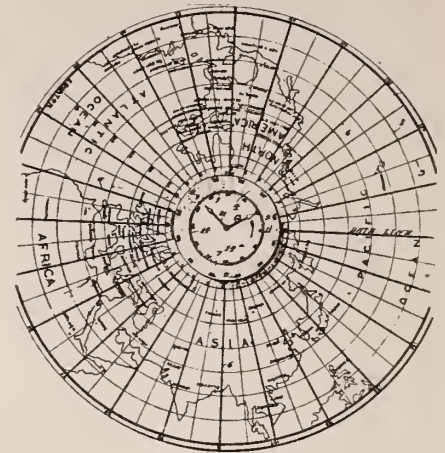

A time-indicator having a stationary disk provided with a field containing a superficial geographical representation including radiating meridian-lines and an international date-line, an annular time-dial revolvably mounted at the center of said disk with its axis at the point from which said meridian-lines radiate, and provided with a scale of time characters, adapted for respective registration with the meridian-lines, and a fractional-time-indicating device mounted within the space encircled by the time-dial and concentric therewith for indicating the fractions of the periods represented upon the time-dial, said fractional-time-indicating device having a movable element operatively connected with for actuation of the time-dial.

- 641,592. CUFF-HOLDER. HENRY V. JOHNSON, Denver, Col. Filed Nov. 17, 1899. Serial No. 737,326. (No model.)

- DESIGN 32,114. DISPLAY SHOW CASE. JOSEPH G. HUTCHINSON, Attleborough, Mass.

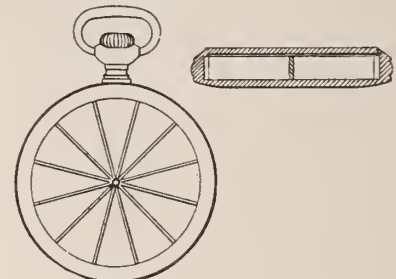

Filed Nov. 13, 1899. Serial No. 736,855. Term of patent 3 1/2 years.

**EXPIRED PATENTS.**

[Recently expired patents of interest to the jewelry trade. Reported especially for THE JEWELERS' CIRCULAR by R. W. Bishop, Patent Attorney, 723 Fifth St., N. E., Washington, D. C., who will furnish complete copies of patents at the rate of 10 cents each.]

[Issued Jan. 16, 1883.]

- 270,615. ENGRAVERS' CHUCK. G. H. STRONG, Chicago, Ill.
- 270,639. ELECTRIC ALARM CLOCK. J. I. CONKLIN, Jr., New York, N. Y.
- 270,644. DEVICE FOR MAKING AND ORNAMENTS WATCH CENTERS. FREDERIC ECAUBERT, New York, N. Y.
- 270,866. METHOD OF MAKING DIES. W. F. WEBER, Newark, N. J.  
[Design issued Jan. 12, 1886, for 14 years.]
- 16,466. WATCH CROWN. E. A. MARSH, Newton, Mass.  
[Design issued Jan. 17, 1893, for seven years.]
- 22,133. SPOON. A. F. JACKSON, Taunton, Mass., assignor to the Reed & Barton Corporation, same place.  
[Design issued July 14, 1896, for 3 1/2 years.]
- 25,769. SILVERSMITH'S STOCK. Philip MUHR, Philadelphia, Pa.
- 25,770. BELT-PIN. BERNARD RICE, New York, N. Y.

# OPTICAL DEPARTMENT.

Note.—From this week till further notice this department will be run as usual, viz.: every other week.

## Encyclopedia-Dictionary and Reference Handbook of the Ophthalmic Sciences.

Copyrighted 1898, by The Jewelers' Circular Pub. Co.

By R. H. KNOWLES, M.D.

[Commenced in issue of July 6, 1898.—Continued from  
page 35, Jan. 10, 1900.]

### PART XLIV.

**Meniscus** (*men-is'-cus*). [Greek, *meniskos* = a crescent.] A lens with a negative and convex surface; a periscopic lens. The term is taken from the fact that this kind of lens resembles a crescent.

**Menotaphlosis** (*men-o-typh-lo'-sis*). [Greek, *mene* = the moon + *tuphlosis* = blindness.] A state or condition of the eye due to a diminution of vision during the night. It is caused by retinal changes from impoverishment of the blood or may be the result of cortical cataract. Synonyms: **Moon blindness**; **Hemeralopia**.

**Meramaurosis** (*mer-am-au-ro'-sis*). Greek, *meros* = a part + *amauroeo* = I make dark.] A condition of the eyes in which part of the field of vision is lost; incomplete or partial amaurosis.

**Meridian** (*mer-id'-i-an*). [Latin, *meridies* = high twelve, noon.] The great circle of the heavens passing through the zenith of the observer. The meridian of the eye is an imaginary circle describing 360 degrees, one-half of which, 180°, is marked upon the trial frame. 0 and 180° are generally found in the horizontal meridian while 90° describes the vertical meridian; the degrees for both eyes are numbered from left to right so that when the axis of a cylinder is found it will correspond to the meridians of the eye.

**Meropia** (*mer-o'-pi-a*). [Greek, *meros* = a part + *ops* = vision.] A diminution of vision. Synonym: **Amblyopia**.

**Mesiris** (*mes-i'-ris*). [Greek, *mesos* = the middle + *iris* = the iris.] The central layer of the ciliary processes.

**Mesochoroidea** (*mes-o-cho-roid-e'-a*). [Greek, *mesos* = the middle + *chorion* = the chorion + *eidōs* = similar.] The central layer of the choroid coat of the eye.

**Mesocornea** (*mes-o-cor'-ne-a*). [Greek, *mesos* = the middle + *cornea* = the cornea.] The central layer of the cornea, the cornea proper, consisting of corneal tissues. The third layer or the true cornea (Valk).

**Mesoretina** (*mes-o-ret'-in-a*). [Greek, *mesos* = the middle + Latin, *retina* = the retina.] The fifth, seventh and ninth layers of the retina.

**Mesoropter** (*mes-o-rop'-ter*). [Greek, *mesos* = the middle + *optesthai* = to fall asleep.] The position of the eyes while in the state of absolute rest.

**Metamorphopsia** (*met-am-or-phop'-si-a*). [Greek, *meta* = across + *morphoo* = I change + *opsis* = vision.] An entoptic phenomenon in which there is a distortion of the image, due to changes in the retinal elements caused by an old inflammation of the retina. Synonym: **Metamorphopsy**.

**Method** (*meth'-od*) [Greek, *methodos* = a way.] A plan or system by which an object is achieved. Landolt's Method is a plan or system for taking a lens measurement, the meter figure 1.3936 + being the unit of measure. This, as applied to the eye, is called a dioptre, so that 1 D. (one dioptre) equals 1.3936+ inches. The English Method is the old system of taking a lens having a one inch focus, the unit of measure being, therefore, one inch.

**Meyer's tissue-paper test.** A simple test for color-blindness which consists of spreading a thin piece of tissue-paper over a larger sheet of paper having the color of red with a border of gray. A complementary tint, or shade of green, will appear in an eye in which there is no color-blindness. The background will not appear green to an individual who is color-blind.

**Microblepharia** (*mi-cro-bleph-a'-ri-a*). [Greek, *mikros* = small + *blepharon* = eyelid.] An unusually narrow and thin eyelid. Synonym: **Microblepharon**.

**Microcoria** (*mi-cro-co'-ri-a*). [Greek, *mikros* = small + *kore* = the pupil.] An abnormal contraction of the pupil. Synonym: **Miosis**.

**Microcornea** (*mi-cro-cor'-ne-a*). [Greek, *mikros* = small + Latin, *cornea* = the cornea.] A small cornea.

**Microlentia** (*mi-cro-len'-ti-a*). [Greek, *mikros* = small + Latin or German, *lentic* = a pea.] A very small crystalline lens.

**Micrometer** (*mi-crom'-et-er*). [Greek, *mikros* = small + *metron* = a measure.] An instrument for the purpose of making an examination of minute bodies. Several combinations are made with the microscope, such as the Micrometer eye-piece and the Micrometer objective, a glass scale which determines the power of magnifying an object by means of a compound microscope. The science of measuring the size of an object by means of a Micrometer is called **Micrometry**.

**Micrommatous** (*mi-crom'-ma-tous*). [Greek, *mikros* = small + *omma* = an eye.] The state of having small eyes.

**Microphthalmos** (*mi-croph-thal'-mos*). [Greek, *mikros* = small + *ophthalmos* = the eye.] A small eye in which there is no pathological changes.

**Micropia** (*mi-cro'-pi-a*). [Greek, *mikros* = small + *opsis* = vision.] An entoptic phenomenon in which surrounding objects appear correspondingly small, due to paralysis of the muscle of accommodation or the result of an old inflammation of the retina so that the rods and cones are rendered smaller

by adhesive bands of lymph which bind down and reduce the calibre of the same. Synonym: **Micropsia**.

**Micropolariscope** (*mi-cro-po-lar'-is-cope*). [Greek, *mikros* = small + Latin, *polaris* = a pole = Greek, *skopeo* = I see.] A microscope having in combination a polariscope.

**Micropsia** (*mi-crop'-si-a*). [Greek, *mikros* = small + *opsis* = vision.] The seeing of objects smaller than they really are, due to paralysis of the ciliary body, brought about by a contraction of the retinal elements caused by inflammation.

(To be continued.)

## Outside Manufacturers Oppose the Camera Combination.

PHILADELPHIA, Pa., Jan. 13.—John Carbutt, manufacturer of photographic supplies, returned yesterday from New York, where he attended a meeting of prominent members of the trade, who met and organized the Photographic Manufacturers' Association of America. He was seen by a CIRCULAR representative and stated that many of the leading manufacturers of cameras and photographic supplies had determined by mutual co-operation to protect the real interests of the dealers in such supplies and to support them in the maintenance of their independence against the alleged exactions of the lately organized camera combination of Rochester.

The meeting was attended by representatives from the Manhattan Optical Co., New York; Gundlach Optical Co., Rochester, N. Y.; New York Dry Plate Co., the G. Gennert Co. of New York; Vive Camera Co., Chicago; Defender Photo Supply Co., Rochester; Cozy Camera Co., New York; the Bullard Camera Co., Springfield, Mass.; Willis & Clements, Philadelphia; the Scovill & Adams Co., New York, and John Carbutt, dry plates, films and paper, Philadelphia.

The organization is a co-operative association for the benefit of the members and retailers, and special emphasis has been placed on the statement, "It is not a trust, but organized to oppose any coalition having for its object the concentration to one source of supply of photographic goods, and for the dealer to assert his right to buy such articles as he may choose from any source whatever."

W. I. Lincoln Adams was elected president; M. B. Hoyt, secretary, and F. H. Hoge, treasurer.

## The American Association of Opticians Are Flourishing.

Following are members just elected to the American Association of Opticians: Leopold Stern, Bogota, Colombia; W. J. Lewis, Topeka, Kan.; Berkman Bros., Charleston, S. C.; John C. Dwyer, New Castle, Pa.; Simon Weissager, Rochester, N. Y.; H. A. Lawton, Wilmington, Del. The total membership to date is 317.

The offices and headquarters of the British Optical Association have been changed to Piccadilly Mansions, 17 Shaftesbury Ave., London W., England.

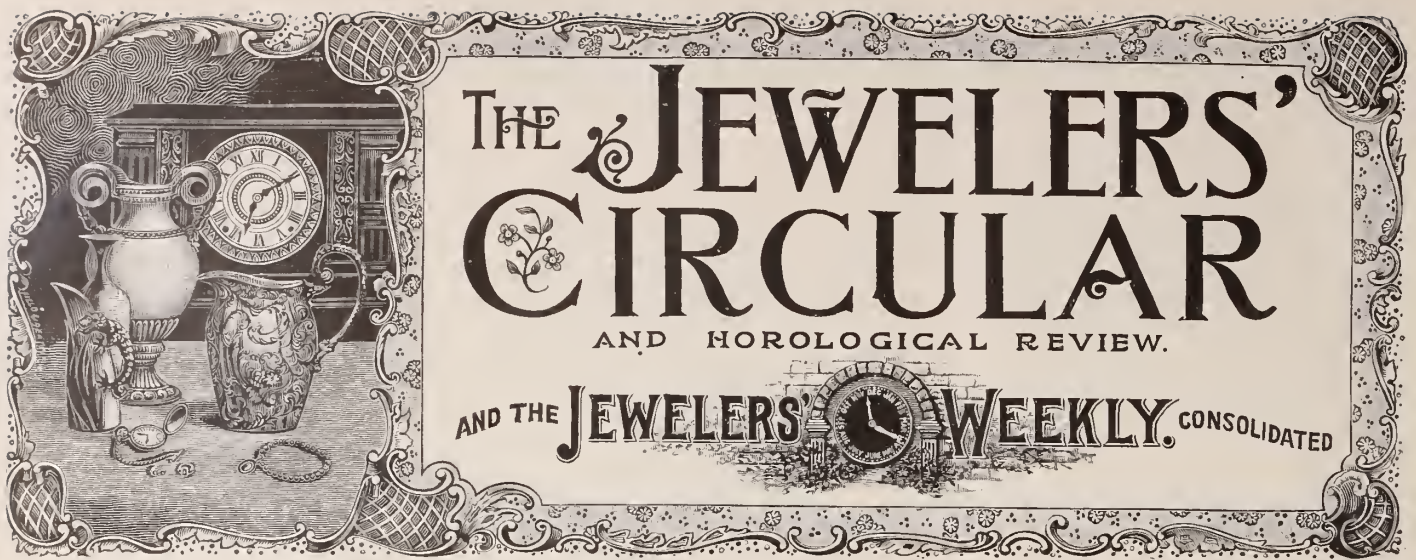

## *Announcement Extraordinary!*

The headpiece above tells a story of great interest to the entire jewelry industry. The story is there plainly told, but some fuller particulars are in order.

During several years past those connected with Jewelry Trade Journalism have become more and more convinced that the trade as a whole demands **ONE GREAT WEEKLY NEWSPAPER** to represent it; to be the chronicler of its happenings and the exponent of its best interests. It was this demand primarily that brought about the plan for the **CONSOLIDATION** of *The Jewelers' Circular* and *The Jewelers' Weekly* into one,

### **“THE JEWELERS' CIRCULAR and THE JEWELERS' WEEKLY CONSOLIDATED.”**

Thus will be merged into one comprehensive journal of the jewelry industry the Oldest Publication in the trade (*The Jewelers' Circular*) and the Oldest Weekly in the trade (*The Jewelers' Weekly*). Thus to the great accumulative influence and prestige of the one, derived from 30 years of unremitting endeavor, of broad, liberal policy, of conscientious study of the trade's interests—this *The Jewelers' Circular*—will be added the prestige obtained by 15 years of equally earnest work on varying lines—*The Jewelers' Weekly*—the sum total representing a measure of usefulness of practically limitless extent.

The uniting of these two journals into one will partake of none of the features of the so-called combine. It contemplates no economies, no curtailments. It will be formed through the will of some of the most expressive minds in the trade, that *one great weekly publication* can best serve the trade; and such a paper “*The Jewelers' Circular and Jewelers' Weekly Consolidated*” will ever be. The uniting of the facilities of the two journals will result in the production of one paper so broad and comprehensive in its scope, so accurate and complete in all its details, so representative of every department of the industry that “*The Jewelers' Circular and The Jewelers' Weekly Consolidated*” will unhesitatingly be universally considered as **THE JOURNALISTIC ORGAN OF THE JEWELRY TRADE**. Such a position each, save for the other, has held, but this high place will be fortified and held impregnable for all time to come.

With its extended circulation, its inexhaustible facilities, its accumulated prestige, and last but not least its hearty and responsive endorsement by the trade, “**THE JEWELERS' CIRCULAR and THE JEWELERS' WEEKLY CONSOLIDATED**” will begin the new era of its career with potentialities for usefulness to the jewelry industry that will be exercised to the utmost. *The consolidation will take effect with issue of Jan. 31, 1900.*

**THE JEWELERS' CIRCULAR PUBLISHING COMPANY.**

### **OPINIONS OF THE DAILY PRESS ON THE CONSOLIDATION.**

*Brooklyn (N. Y.) Standard-Union,*  
Jan. 4.

Two of the oldest of the jewelry trade papers, THE JEWELERS' CIRCULAR and THE JEWELERS' WEEKLY, have consolidated, and the name of the new journal is THE JEWELERS' CIRCULAR AND THE JEWELERS' WEEKLY. The publishers announce that there will be no curtailment of their present staffs, and that with their combined efforts they will be able to turn out a larger paper, which will more fittingly represent the jewelry trade. The combination of their interests has been accomplished with the help of the trade, who have long sought this combination.

*Philadelphia (Pa.) Record,* Jan. 4.

THE JEWELERS' CIRCULAR and THE JEWELERS' WEEKLY, which have been the recognized newspapers of the jewelry trade, have been consolidated and after the last day of this month will be issued as one publication. Both journals have been heretofore published on a rather broad scale, and the issues of each have been very attractive, not only to the trade, but to the general reader, and as it is announced that none of the former features will be discontinued, it is expected that some very attractive numbers will be issued.

*Harrisburg (Pa.) Telegraph,* Jan. 5.

Beginning with the issue of Jan. 31, 1900, THE JEWELERS' CIRCULAR and JEWELERS' WEEKLY, of New York, two of the leading trade publications of the country, will appear as one publication, the title being THE JEWELERS' CIRCULAR and THE JEWELERS' WEEKLY, Consolidated. THE JEWELERS' CIRCULAR is the oldest publication in the trade, and THE JEWELERS' WEEKLY the oldest weekly in the trade. Both have been very prosperous and their consolidation means still greater prosperity and a publication of inestimable value to the trade.

## OPINIONS OF THE DAILY PRESS ON THE CONSOLIDATION.

CONTINUED FROM PAGE 58.

### *Birmingham (Ala.) Ledger.*

The consolidation of THE JEWELERS' CIRCULAR and THE JEWELERS' WEEKLY, both of New York City, has been announced, the new order of things to become operative on Feb. 1, 1900. These have been separately the strongest influences of their kind in trade journal circles, and together they promise great things for the business.

### *London (O.) Nickel Plate.*

THE JEWELERS' CIRCULAR and THE JEWELERS' WEEKLY, both New York papers, but well known to the dealers of this city, have been consolidated, and on Jan. 31 they will appear as one paper under the name, THE JEWELERS' CIRCULAR and THE JEWELERS' WEEKLY, *Consolidated*. It will be the only weekly paper of note published in the interests of the trade and the greatest paper of the kind issued in this country. This move has not been made for economy, but in order to produce a paper that will meet every requirement of the trade and chronicle the events of interest in the best possible manner.

### *Allentown (Pa.) Chronicle and News.*

As a matter of more than ordinary interest to the jewelry trade throughout the country will be the announcement of the proposed consolidation of THE JEWELERS' CIRCULAR and THE JEWELERS' WEEKLY, which consolidation will take effect with the issue of Jan. 31. Each paper has heretofore been, save for the other, the representative trade journal in their line, and the consolidation will result in the publication of a journal that will be unquestionably the journalistic organ of the jewelry trade, which trade can congratulate itself on having such an able and accurate exponent.

### *Syracuse (N. Y.) Journal.*

The consolidation of THE JEWELERS' CIRCULAR, the oldest publication devoted to the interests of the jewelry trade, and THE JEWELERS' WEEKLY, the oldest weekly in the trade, is announced to take effect with the issue of Jan. 31, 1900. THE JEWELERS' CIRCULAR has been in successful and prosperous existence for 30 years, and THE JEWELERS' WEEKLY was established 15 years ago. This uniting of interests and facilities can but result in a publication broad and comprehensive in scope and detail, and thoroughly representative of every branch of the jewelry industry.

### *Davenport (Ia.) Democrat.*

There will be some local interest to the jewelry trade here in the announcement of the consolidation of the two leading journals of the jewelry industry—THE JEWELERS' CIRCULAR and THE JEWELERS' WEEKLY. The union takes effect the last of this month, and the result will be a weekly publication that will be better than either of the separate publications have been, and the warm competition that there has been between them up to date has produced a good article. Both circulate extensively in Davenport and throughout the west.

### *Ohio State Journal, Jan. 18.*

A matter of interest to jewelry dealers is the proposed combination of two of the largest weekly journals representing their interests, THE JEWELERS' CIRCULAR and THE JEWELERS' WEEKLY, both of New York. The change will be made with the issue of Jan. 31, and the new paper will be known as THE JEWELERS' CIRCULAR and THE JEWELERS' WEEKLY, *Consolidated*.

### *Syracuse (N. Y.) Herald.*

An announcement of much interest to the jewelry trade and a subject of congratulation for the journals interested, is the consolidation of THE JEWELERS' CIRCULAR and THE JEWELERS' WEEKLY. THE JEWELERS' CIRCULAR is the oldest publication in the trade, having been established 30 years, and gained wide prestige and influence through years of unceasing endeavor for the promotion of the trade's interest. THE JEWELERS' WEEKLY is the oldest weekly devoted to the trade, having been in existence 15 years, and gained for itself an enviable position among jewelry publications. The uniting of the facilities of the two journals will result in a publication broad and comprehensive in scope, accurate and complete in detail, and representative of every department of the jewelry industry.

### *New York Sun.*

Beginning on Jan. 31, THE JEWELERS' CIRCULAR and THE JEWELERS' WEEKLY, the two oldest papers devoted to the jewelry trade, will appear as one paper, under the title of THE JEWELERS' CIRCULAR and THE JEWELERS' WEEKLY, *Consolidated*. The papers will be issued separately to-day, and each will contain an announcement of the consolidation, in which it is explained that the merging of the interests of the papers into one publication is the result of a general demand on the part of the trade.

### *New York Tribune.*

For several years past those connected with jewelry trade journalism have become more and more convinced that the trade as a whole demands one great weekly newspaper to represent it. It was this demand primarily that has brought about a plan for the consolidation of THE JEWELERS' CIRCULAR and THE JEWELERS' WEEKLY into one periodical, THE JEWELERS' CIRCULAR and THE JEWELERS' WEEKLY, *Consolidated*. The former is the oldest publication and the latter the oldest weekly in the trade. It is believed that the union of the facilities of the two journals will result in the production of a paper so representative of every department of the industry that it will be universally considered the journalistic organ of the jewelry trade. The consolidation will take effect with the issue of Jan. 31, 1900.

### *Meriden (Conn.) Record.*

A consolidation is to be consummated Jan. 31 that will be of great interest to the silver and jewelry trade. On that date THE JEWELERS' CIRCULAR, the oldest publication in the trade, and THE JEWELERS' WEEKLY, the oldest weekly in the trade, will be merged into one. The publishers announce that no economies or curtailments will be made, but the new issue will be greater and better than ever before. It has been determined that one great weekly publication, making a conscientious study of the trade's interests, is demanded, and therefore the consolidation is being perfected.

THE JEWELERS' CIRCULAR and THE JEWELERS' WEEKLY, *Consolidated*, is the name under which the new paper is to be published, and it is probable it will be accepted as the journalistic organ of the jewelry trade. With its extended circulation and accumulated prestige, it will undoubtedly meet with warranted success.

### *Newark (N. J.) Call.*

Announcement was made last week that the two foremost organs of the jewelry trade, THE JEWELERS' CIRCULAR and THE JEWELERS' WEEKLY had joined their forces, and the consolidated publication will be known as THE JEWELERS' CIRCULAR and THE JEWELERS' WEEKLY, *Consolidated*.

### *New Haven (Conn.) Register.*

An announcement of more than usual interest and importance to the jewelry and silver ware trade is that of the consolidation of the two best known journals in that trade—THE JEWELERS' CIRCULAR and THE JEWELERS' WEEKLY—taking effect with the issue of Jan. 31, 1900. Both are published in New York City.

Trade journalism to-day occupies a place among the industries of the country that meets requirements little understood by the public generally. In all lines, nowadays, merchants and manufacturers are eager to seize upon the medium which gives reliable news of their particular industry and early special information of a technical character. The value of advance knowledge thus obtained is frequently inestimable. The trade journal is, therefore, a permanent fixture, and to no other trade is it more valuable than to the jewelry and silver ware trade.

THE JEWELERS' WEEKLY and THE JEWELERS' CIRCULAR have occupied the highest round in the ladder of jewelry trade journalism. Both had ministered to their subscribers with rare success and intelligence, but the trend of the past few years has been towards a demand for one comprehensive publication that should chronicle faithfully all trade events of interest and become the exponent of the best interests of the industry and business it represents. This demand is now happily met in the junction of the two great forces—THE JEWELERS' CIRCULAR, standing for the oldest publication, and THE JEWELERS' WEEKLY for the oldest weekly in the trade. The result must necessarily be the production of a journal that will be unhesitatingly looked upon and welcomed by the trade as its foremost and best representative.

### *Jacksonville (Fla.) Evening News.*

Two of the most influential, if not the most influential, of the organs of the jewelry trade are to be combined into one strong trade journal. These publications are THE JEWELERS' CIRCULAR of thirty years' standing and the JEWELERS' WEEKLY, which has been in existence for fifteen years. Their union will place at the command of jewelers a periodical characterized by a policy of unremitting attention to the best interests of the trade.

### *Jacksonville (Fla.) Times-Union.*

THE JEWELERS' CIRCULAR, the oldest publication in the trade, and THE JEWELERS' WEEKLY, the oldest weekly in the same line, are about to be merged into one broad, comprehensive weekly organ for the jewelers of the United States under the name of THE JEWELERS' CIRCULAR and THE JEWELERS' WEEKLY, *Consolidated*. The combined publication contemplates no curtailment or economies, but will devote its energies to meet at every point all possible requirements of the jewelry industry.

### *Lancaster (Pa.) Examiner.*

Announcement is made of the proposed consolidation of THE JEWELERS' CIRCULAR and THE JEWELERS' WEEKLY, representative journals of the jewelry trade, the same to take effect with the issue of Jan. 31. The consolidation will result in a publication which will be of great interest and value to the trade.

### *Birmingham (Ala.) News.*

THE JEWELERS' CIRCULAR and THE JEWELERS' WEEKLY, both New York publications, have consolidated, the new arrangement to take effect Jan. 31. This is a combination of two of the oldest trade journals in the country, and brings together potent influences in the advancement of the business of the jewelers.

# Terra Cotta.

*We have the largest assortment of Artistic Domestic Terra Cotta to be seen under one roof. This line consists of Busts, Groups and Figures, which are painted by ARTISTS in oil colors; the MODELING is perfect and not to be compared in any way with the poorly made imitations, although ours are at least as low in price. Samples now ready.*



## Geo. Borgfeldt & Co.,

West Fourth, Third and Wooster Sts.,

NEW YORK.

China.

Bric-à-brac.

Italian Marbles.

Bronzes.

Clocks.

Parisian Novelties.

Artistic Pottery.

China Paintings.

Pictures.

American Cut Glass.

Onyx Pedestals.

Mirror Platteaux.

Vernis Martin

Cabinets.

Antique Brass.

Antique Lamps.

Venetian Iron.





## THE RAMBLER'S NOTES.

WHAT THE RAMBLER SAW AND HEARD AMONG THE DEALERS IN ART POTTERY, CUT GLASS, BRONZES, ETC.

ALL the representatives of the leading English potteries that supply the jewelry trade are now in this country. Fred J. Pointon, of Minton's, Ltd., and Ashley Cooper, representing Brown-Westhead, Moore & Co., manufacturers of Cauldon ware, arrived in this country Wednesday on the *Oceanic*. Wm. Beach, representing Doulton & Co., and Elijah Cooper, of the Foley China Works, arrived Jan. 13 on the *Etruria*. John A. Service, who recently arrived in this country, now represents Josiah Wedgwood & Sons, the Royal Worcester Porcelain Co. and Webb & Sons, cut glass manufacturers. Most of these representatives are now in Boston and will open up their samples in New York at an early date.

CUT GLASS MANUFACTURERS' BANQUET. THE Cut Glass Manufacturers' Association of America met at their annual convention and dinner Saturday evening, Jan. 13, at the Hardware Club, Murray St. and Broadway. T. G. Hawkes, of T. G. Hawkes & Co., presided at the dinner, which was attended by representatives of about 20 leading manufacturing concerns. An informal discussion took place on affairs of general interest to the trade of those represented. This organization meets twice a year at a banquet, which serves to engender harmony and good will among the competitors in the cut glass business. J. D. Bergen is secretary of the organization.

A MAGNIFICENT STOCK. AT the warerooms of Chas. Ahrenfeldt & Son, 52 Murray St., New York, are now to be seen the samples of the various lines of china, glass, art pottery, bric-à-brac, etc., which they import, and it may be said without hesitation that the novelties to be found among them are greater in number and more pronounced in effect than at any other Spring season for many years. In pottery may be seen a wide variety of new goods in all lines, from the cheapest Bohemian faience to the most artistically decorated Vienna ware. Two of the lines which

stand out most prominently in this department are the Vienna and the Royal Bonn. The former contains the beautiful luster and artistic color effects introduced with such success last year, but in even richer varieties than formerly. The Bonn ware shows the usual number of new styles, among which should be mentioned an entirely new decoration. This, while retaining the yellow, brown and green shaded color effects, which are still in great demand, shows these hues in connection with landscape instead of floral designs, as formerly. The pieces in which this decoration is to be seen are vases, urns and loving cups, showing changes in shape that will no doubt prove as popular a feature as will the new decorations.

THE RAMBLER.

### The Snuff Boxes of Frederick the Great.

FREDERICK THE GREAT is known to have been a great lover of snuff boxes. He possessed a collection of 1,500 boxes, among which there were many costly specimens. The King every year had made, by various Berlin jewelers, valuable boxes after his own sketches and directions. There are still in the crown treasury 14 boxes of Silesian chrysope and agates with masterly gold mountings and beautiful ornaments of diamonds, mostly foliated, which bear strong testimony of the costliness of the King's taste. It is hardly probable that he used these expensive *tabatières* himself, for that kept in the Hohenzollern Museum and from which he took snuff in his last hour on earth, is a very simple one. Possibly those boxes were intended for presents to meritorious generals or other favored persons.

Last year there was shown in St. Petersburg, at the Hermitage, a very handsome and costly snuff box, almost as precious as the Berlin gala pieces in the crown treasury, which, by the way, were exhibited about five or six years ago in the Museum of Applied Arts, at Berlin. This box is said to have been presented by Frederick the Great to a deserving general in his army. A slip of paper bears the following inscription in the King's own handwriting: "Hier schenk ich ihm das, heb er es wohl auf, denn es ist kein Dreck" (I present this to you, preserve it well, for it is no trifle). It is difficult to ascertain how this box got to St. Petersburg. Probably it formed part of the booty from the time of the Seven Years war.

What became of the large snuff box collection of the King? If it really existed

in such numbers, as Diendoné Thiélbaut states in his "Reminiscences of Berlin," published in Paris in 1805, it has doubtless been turned into money or been used for other purposes under King Frederick William II. or in the time of great distress under Frederick William III. In the first volume of the "Vertraute Briefe über die inneren Verhältnisse am Preussischen Hofe seit dem Tode Friedrichs II." (Confidential letters on the intimate conditions, at the Prussian Court, since the death of Frederick II.), Amsterdam and Cologne, 1808, Peter Hammer, whose anonymous author is the Baron von Coelln, it is especially mentioned that little piety was used in the treatment of the estate of the great King and that Sanssouci particularly suffered terribly by this neglect, having acquired an altogether different physiognomy in its interior. Only much later and especially under King Frederick William IV. has it been attempted to restore to the interior that character which breathes the spirit of the great King.

### Gorgeous Swords.

OF gorgeous swords, which are not so much weapons as settings for precious stones, the most valuable in England is said to be the one presented by the Egyptians to Lord Wolseley and valued at £2,000; but this sum is comparatively little for a bejeweled sword if the value of the sword brought over to Europe by the late Shah of Persia on his first visit—namely, £10,000—can be taken as a standard of what a diamond-hilted weapon ought to cost. Those who can recall that wonderful sabre will be somewhat skeptical about the existence of the Gaikwar of Baroda's gorgeous blade, which is supposed to be worth more than 20 swords of equal beauty and value to the Shah's; but it is popularly supposed that the diamonds, rubies and emeralds with which it is thickly encrusted bring up its value to about £220,000, which, at 4 per cent, represents an income of almost £9,000 a year, and renders the possession of such a sword something more than a mere luxury.—*Chambers's Journal*.

The Ceramic Art Co. are working on an entirely new lot of samples for the Spring trade. This company are maintaining their reputation in turning out marketable goods and are expecting big things from their new line.

## Trade-Mark Information.

**Note.**—The publication of our work, "Trade-Marks of the Jewelry and Kindred Trades," containing over 2,250 marks, all told, the accumulation of various works of reference and the ramifications of our business enable us to trace to their origin nearly all marks that may be found on jewelry, silver ware, art pottery and kindred lines, of both American and foreign make. All questions in regard to trade-marks will be cheerfully answered. We would be pleased to have the trade seek the benefit of our facilities regarding the identity of any marks they cannot trace. We would prefer to receive the article for examination; for if the mark is of foreign origin, the slightest difference between a drawing and the original is of great importance.

No question is too trivial nor too complicated for consideration under this department.

GREENVILLE, S. C., Jan. 5, 1900.

Editor of THE JEWELERS' CIRCULAR:

Whose trade-mark is this, please? We find it on a fancy brooch.

Yours truly,  
GILREATH-DUREAM COMPANY.



**ANSWER:**—This, slightly varied, is the trade-mark of H. A. Kirby Co., 9-13 Maiden Lane, New York.

BANGOR, Me., Jan. 9, 1900.

Editor of THE JEWELERS' CIRCULAR:

Have sent you a rough idea of a trade-mark.



STERLING.

Will you please let me know the maker? Obliging,  
Yours, etc.,

W. C. BRYANT.

**ANSWER:**—This is the trade-mark of H. H. Curtis Co., North Attleboro, Mass., and 9-13 Maiden Lane, New York. It is reproduced on page 41 of "Trade-Marks of the Jewelry and Kindred Trades," published by the Jewelers' Circular Pub. Co.

NEW YORK, Jan. 15, 1900.

Editor of THE JEWELERS' CIRCULAR:

Will you kindly let me know name and address



of manufacturers using this trade-mark?

Respectfully,

G. HIRSHFIELD.

**ANSWER:**—This mark is used by the Watrous Mfg. Co., Wallingford, Conn. It is illustrated on page 50 of "Trade-Marks of the Jewelry and Kindred Trades," published by the Jewelers' Circular Pub. Co.

JANESVILLE, Wis., Jan. 11, 1900.

Editor of THE JEWELERS' CIRCULAR:

Enclosed is a fork which we cannot locate the maker of by your book of trade-marks or any



other means at our command, so we beg you to find the maker for us. Yours very respectfully,  
HALL, SAYLES & FIFIELD.

**ANSWER:**—This fork is made by Simpson, Hall, Miller & Co., now of the International Silver Co., Wallingford, Conn., or 9-13 Maiden Lane, New York. It is their "Warwick" pattern, and the trade-mark it bears, but which is not clearly stamped, is to be found on page 48 of "Trade-Marks of the Jewelry and Kindred Trades," published by the Jewelers' Circular Pub. Co.

### To Distinguish Electro-Gilding from Fire-Gilding.

**I**F a gilt object is treated with nitric acid the gold will separate in leaves owing to the action of the nitric acid on the metal below. These leaflets will be of the same golden color both on the inside and outside, if the article had been electro-plated or gilt by the wet process at all. But, in the case of fire-gilding the gold leaves are darker (brownish and dull) on the inside. In electro-gilding the gold films held against the light appear dense and in fire-gilding pierced by fine holes. It is best to treat the articles to be tested, with the file, so that the nitric acid can attack the ground.

F. L. Stone, Caro, Mich., is having the store which he recently purchased fitted up, and will soon occupy it with his jewelry stock.

## WORKSHOP NOTES.

**Cement for Metals.**—Plaster, 100 grammes; gum arabic, 25 grammes; alum, 5 grammes. Dissolve the alum in the water necessary to mix the plaster, next the gum arabic and stir the plaster in this water.

**Cement for Marble and Alabaster.**—Cement, 10 grammes; slaked lime, 5 grammes; powdered white lead, 5 grammes; pulverized chalk, 1 gramme; silicate of soda, 25 grammes, and enough water to make a homogeneous paste. Use this composition at once, for it hardens very rapidly.

**Moulding Wax.**—Below are the quantities for preparing moulding wax: Wax, 500 grammes; essence of turpentine, 1,000 grammes—namely, double the weight of the wax. For dark colors pure yellow wax is employed; for white or light tints, white wax. For coloring, take either yellow ochre, red ochre or alkanet. The ochers are put into the essence at the same time as the wax. The alkanet must be added to the essence about 12 hours before the wax. Then it is decanted and the wax added. All this is done in the cold.

**Black Bronze on Zinc.**—To impart a black color to zinc objects and to obtain a solid coating take: Alcohol, 1 liter; chloride of antimony, 100 grammes; hydrochloric acid, 50 grammes. Dissolve the antimony in the alcohol and add little by little the hydrochloric acid, which will render the mixture clear. Dip a brush into this solution, and rub the articles with it. Dry off this first coat and apply a second one. Dry this rapidly in an oven. Next pass a wad soaked with boiled linseed oil all over the piece. Repeat the application of oil several times to obtain a prettier black. Very good results may also be obtained for small pieces by dipping them into a solution of nitrate of manganese and drying the pieces either over coal or over a gas or a spirit lamp.

The Ezra F. Bowman Horological Institute, Lancaster, Pa., has taken a number of new students in watchmaking and engraving since the first of the year.

## PAIRPOINT MFG. CO.,

NEW BEDFORD, MASS.

New Line for 1900 ...in... Preparation.

Silver  
Plate  
AND

Rich...  
Cut Glass.

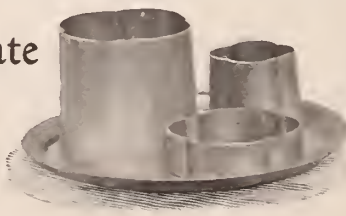

38 Murray St., New York City.

Temple Building, Montreal.

## The Standard Trading Corporation

LIMITED,

24 CURSITOR ST., LONDON, E. C.,

SPECIALLY ADAPTED FOR PUTTING  
QUANTITIES ON THE MARKET,

Wishes to hear from jewelry manu-  
facturers desiring to increase  
business and ship to England.

Spot Cash for All Orders.



Our New Samples are ready for the Spring Trade.  
**"ACME"**  
 Lever Collar, Link and Sleeve Button.

STANDARD OF THE WORLD.

Manufactured in an Endless Variety of New and Original Designs.

We have made large additions to our already handsome and extensive lines in  
**CHAINS, RINGS, LOCKETS, CHARMS, BRACELETS AND EMBLEMS.**

See our line of EIFFEL PONY, FOB and DICKENS CHAINS.

NEW SAMPLES OF NOVELTIES IN Hearts, Ornaments, Medallions, Amulets and Tablets.



Drop us a postal and our salesman will call.  
 We sell the Jobbing Trade only.

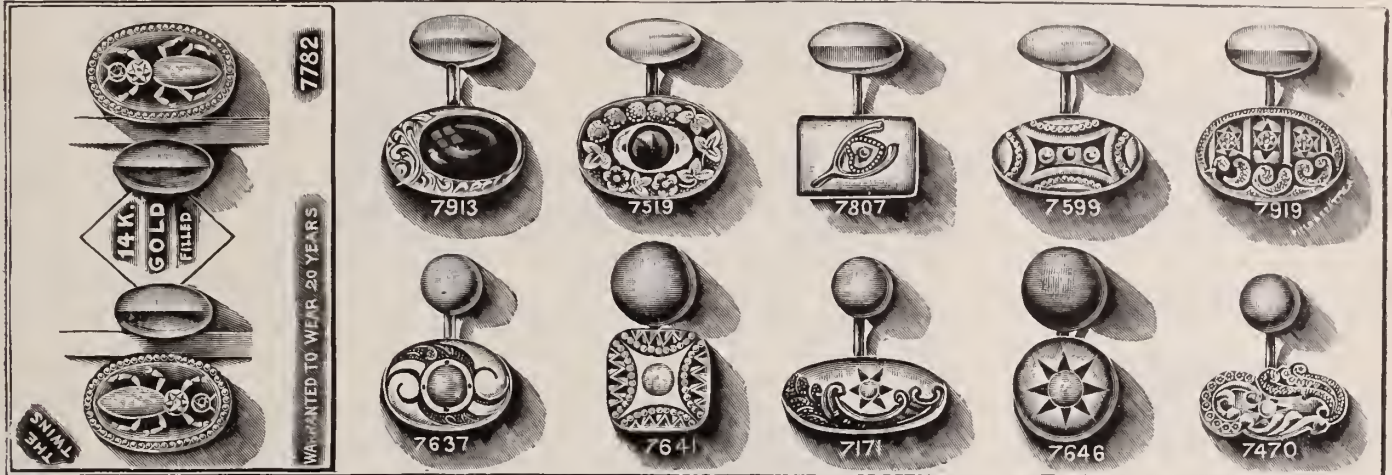

New York Office,  
 11 John Street.

**S. & B. LEDERER CO.**  
 FACTORY, PROVIDENCE, R. I.

Chicago Office,  
 131 Wabash Avenue.

"Engravings Attract Where Type Is Unnoticed."  
 Illustrations of every Description  
**THE BATTERY**  
 Knotters  
 ELECTROMORS  
 NEW YORK, N. Y.  
 Telephone No. 645  
 89 FULTON ST.  
 P. John.

**DR. KNOWLES'**  
 ...PRIVATE COURSE IN...  
**Optometry.**

SPECIAL RATES IN THE  
 CORRESPONDENCE DEPARTMENT.

**"EYE DEFECTS,"**

A New Book, in cloth, Price, \$1.00.

For terms and important particulars, write to  
**R. H. KNOWLES, M. D.,**  
 11 John Street, New York.

**CROUCH & FITZGERALD,**



Jewelry Trunks  
 and Cases,  
 161  
 Broadway,  
 Bet. Cortlandt and  
 Liberty Sts.  
 688 B'way,  
 723 6th Av.  
 NEW YORK.

**Push—Grit—Energy.**

A long time ago we concluded that the only way to succeed was  
 by practicing Push, showing Grit and never diminishing Energy.  
 The result is shown in our

**1900 Line of Jewelers' Findings**

THEY INCLUDE

TUBE SETTINGS FOR COMBS, EBONY MOUNTS, PATENT  
 CLUSTER SETTINGS.

**MEDALLION HEADS**

FOR BROOCH PINS, BELT BUCKLES, LINK BUTTONS, ETC.

Large Scrolls for Picture Decorations and everything in  
 Findings for the Manufacturer.

**HEIMBERGER & LIND,**

158 PINE ST., METCALF BUILDING, PROVIDENCE, R. I.

"BY USING OUR GOODS, YOUR GOODS WILL SELL."

# CHAS. F. WOOD & CO., DIAMONDS

1 MAIDEN LANE, NEW YORK.

IMPORTERS AND CUTTERS.

## DIAMONDS.

LARGE ASSORTMENTS.

DESIRABLE SIZES.

ATTRACTIVE PRICES.

**R., L. & M. FRIEDLANDER,**

30 MAIDEN LANE, N. Y.

97 HATTON GARDEN, LONDON.

## HALL CLOCKS,

*Mantel Clocks,*

*Traveling*

*Clocks,*

*Clock Sets,*

*Regulators,*

*Bronzes,*

*Vases, Ivory*

*Miniatures*

*and Art Goods.*

Fall Line Now Ready.

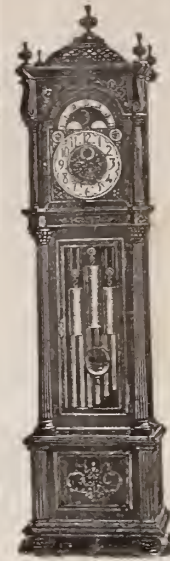

**Harris & Harrington,**

32 and 34 VESEY ST., NEW YORK.

Sole Agents to the Trade for J. J. Elliott & Co., London.

Arnstein Bros. & Co. AND CUTTERS OF DIAMONDS  
 65 Nassau St. NEW YORK.  
 Cor. John.

DIAMONDS Importers and Cutters.  
 L. & M. KAHN & CO., 172 Broadway, Cor. Maiden Lane, N. Y. DIAMONDS

American  
Watch Case Co.

**A.W.C.CO**

Have Merit—Superiority—Reputation.

9 to 13 Maiden Lane, New York.

## HOROLOGICAL DEPARTMENT,

BRADLEY POLYTECHNIC INSTITUTE,

PEORIA, ILLINOIS.

Largest and best watch school in America. We teach Watch Work, Jewelry, Engraving, Clock Work, Optics. (Formerly Parsons' Horological Institute.) Catalogue Free.

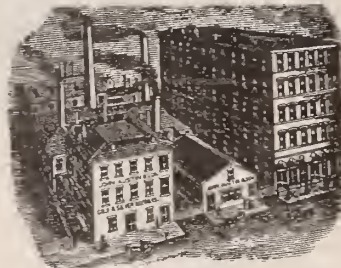

38 YEARS OF  
HONEST RETURNS

IS OUR GUARANTEE OF SATISFACTION  
TO ALL OUR CUSTOMERS.

WE DO OUR OWN SMELTING.

**JOHN AUSTIN & SON,**

ASSAYERS, REFINERS AND SMELTERS.

74 & 76 Clifford St., Providence, R. I.

### TO BLOW EFFECTIVELY IS AN ART

which we never practice personally; but we have invented a machine which does it for us, called the

"Reichhelm Pressure Blower."

This, with Gas Furnaces and Jewelers' Tools generally, is the stock in trade of

**E. P. REICHHELM & CO.,**  
23 JOHN STREET, NEW YORK CITY.



GOLD AND SILVER PENCILS,  
PENHOLDERS, &c.

**FAIRCHILD & JOHNSON CO.**

Office and Factory,  
220 FOURTH AVENUE, N. Y.

## Satisfaction

AND....

## Promptness

is the secret of our success. Our chief aim has always been to render prompt returns and to give satisfaction to all our customers.

**CONLEY & STRAIGHT,**

GOLD AND SILVER

REFINERS, ASSAYERS and  
SMELTERS,

236 Eddy Street. PROVIDENCE, R. I.

**ALOIS KOHN & CO.,** 4 MAIDEN LANE, SOLID GOLD CHAINS,  
Near Broadway, N. Y.

We call the attention of the Trade throughout the country to our line of

**LORGNETTE AND GUARD CHAINS.**

Will send Samples on Memorandum on receipt of satisfactory reference. Correspondence Solicited.

**EMPIRE COMBS. SIDE COMBS.**

GOLD AND JEWELLED ORNAMENTED.

SPECIALTIES IN ROMAN WORK.

**DAY, CLARK & Co.,**

MAKERS OF FINE JEWELRY,

23 MAIDEN LANE, N. Y.

SEE ANNOUNCEMENT ON PAGE 58.





