

American
Watchmaker
and Jeweler.
Abbott.

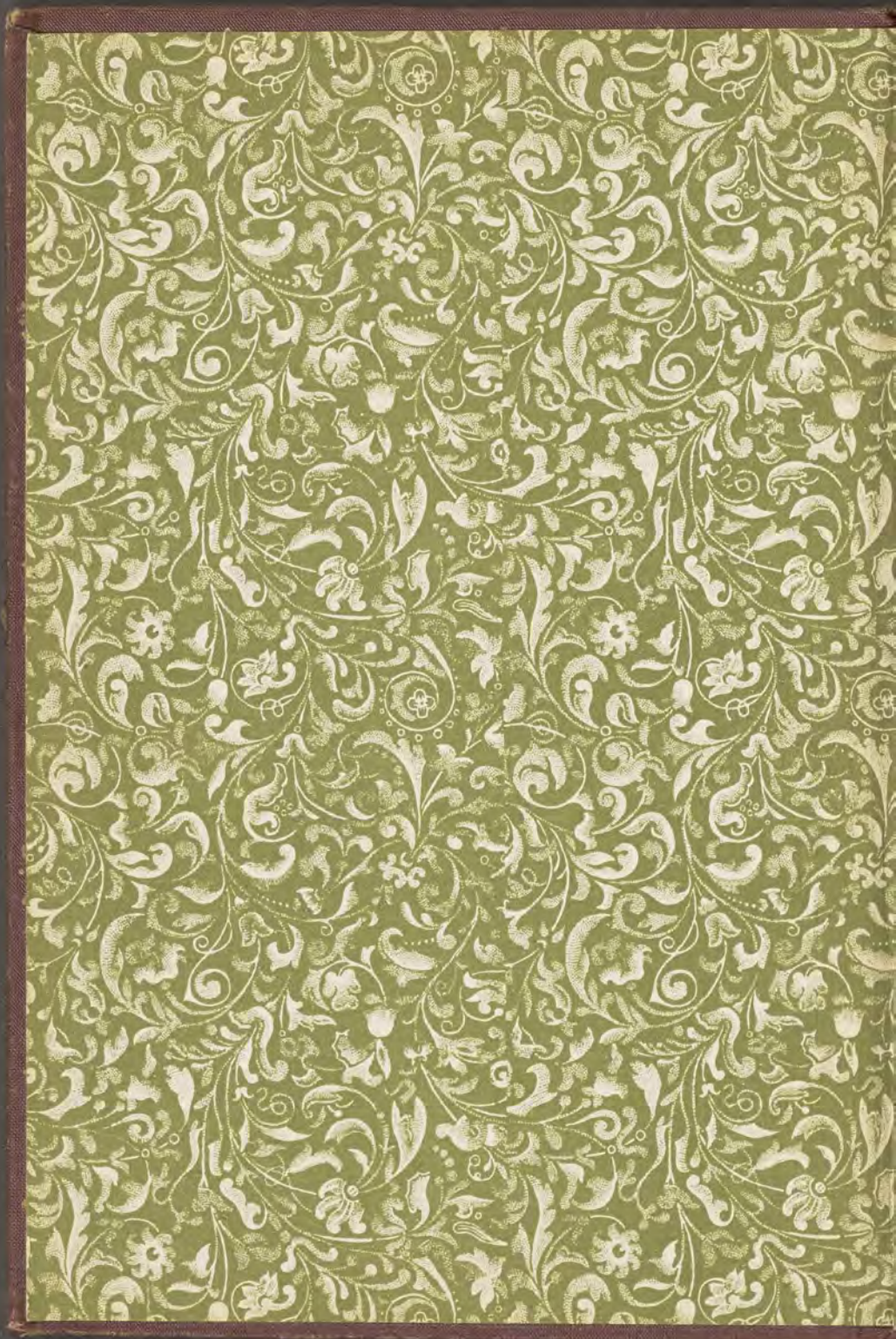

sns

42641

\$75.00

✓ RTL 018730

37.50

ABBOTT'S

AMERICAN WATCHMAKER

AND JEWELER

AN ENCYCLOPEDIA
 FOR THE HOROLOGIST, JEWELER, GOLD AND SILVERSMITH

CONTAINING HUNDREDS OF PRIVATE
 RECEIPTS AND FORMULAS COMPILED FROM THE BEST
 AND MOST RELIABLE SOURCES, COMPLETE DIRECTIONS FOR USING
 ALL THE LATEST TOOLS, ATTACHMENTS AND DEVICES
 FOR WATCHMAKERS AND JEWELERS

Summary

BY HENRY G. ABBOTT

ILLUSTRATED WITH 288 ENGRAVINGS

1192

2K-2
 716E
 67549726

Chas. W. Geager,

3-30-08

PREFACE.

THE first edition of this work was published in 1893 and met with an unexpected and unprecedented sale, and a second edition was placed upon the market in less than ten months. So much new matter was added that it was found necessary to reset the entire work in smaller type in order to keep the volume within the price at which it was originally placed on the market. It is the first and only book, of which the author has any knowledge, which illustrates and describes modern American tools for the watchmaker and jeweler. The ambitious workman is always in search of knowledge, in search of new ideas, new tools and new methods. Patient study, constant practice and ambition are requisite to become proficient in any art. The demand for skilled workmen is constantly increasing, and a person wishing to thoroughly master any art, must be to a certain extent capable of self instruction. To be proficient in any art a man must not be deft of touch alone, but the head must also play its part. The watchmaker is very often called upon, especially in country towns, not only to clean and repair watches and clocks, but is often asked to repair music boxes, cameras, fishing reels, phonographs, musical instruments, electric motors, statuettes, pipes and a variety of objects too numerous to mention. It would be next to impossible for the workman to remember all the various instructions, hints, pointers, formulas and receipts which he has read or heard about, and the author believes that such persons will welcome this volume and that it will prove valuable for reference in cases of emergency. This, the twelfth edition, has been entirely revised and enlarged, so that it is more complete than former editions. The escapements have all been re-drawn and the descriptions re-written and many new departments added.

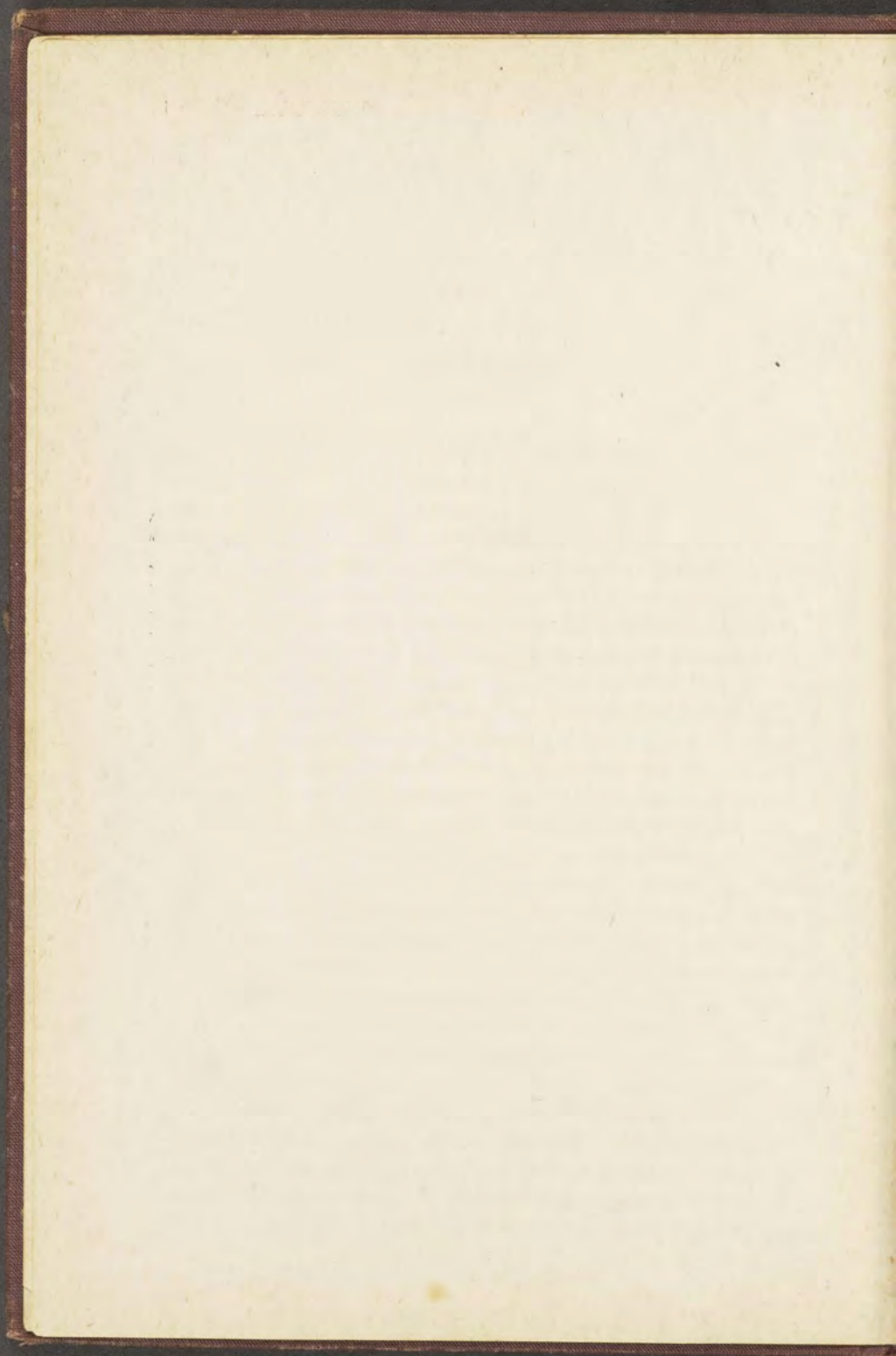

ABBOTT'S AMERICAN
WATCHMAKER AND JEWELER

AN ENCYCLOPEDIA FOR THE
HOROLOGIST, JEWELER, GOLD AND SILVERSMITH

ABBEY. To him or his assistant, Graham, is attributed the invention of the cylinder escapement.

ACCELERATION. This term in horology is applied to the steady gaining in the rate of a time-keeper, particularly to be observed in new movements. It is positively known to occur in marine chronometers, watches as a rule not being subjected to tests sufficiently accurate to detect it in them. There is but little doubt that the hairspring is the cause of acceleration. Old movements after being re-sprung sometimes accelerate, particularly if the overcoil is manipulated too much when timing. It is claimed that springs increase slightly in strength for some time after they are subjected to continuous action just as bells are found to alter a little in tone after use. It is said that the very best chronometers, after going for a year or two, will accelerate by about three or four seconds per day. M. Jacob attributes this acceleration to the fact that chronometers are exposed to heat oftener and for longer periods than to cold, and since the balance is thus more frequently contracted it follows that after a time the segments will not return exactly to their initial positions. There will therefore be necessarily a slight acceleration of the rate.

Dent believed that it was due to the combination of oxygen of the air with the steel hairspring, so that after a time its rigidity is increased.

M. Villarceau attributed it to the influence of the escapement and that it arises from the fact that the impact communicating the impulse occurs before the balance has arrived at its neutral position.

M. H. Robert attributes it to the fact that the resistance opposed by oil at the pivots of the escape wheel differs from that at the pivots of the balance.

Flat springs do not accelerate as much as those having overcoils. Palladium springs accelerate much less than hardened steel springs.

ACIDS AND SALTS. Acids and salts of various kinds are employed by the watchmaker and jeweler, but he should never keep them in proximity to his tools or work, or he may have cause to regret it some day. It is advisable to keep them in glass stoppered bottles.

Acetic Acid of commerce varies considerably in concentration and is usually of a very light yellow color. It is very acid in taste and has a pungent odor by which it is easily distinguished.

Alum is sometimes used for removing the stains left by soldering, in lieu of acids, and is also used in removing broken screws from brass plates by immersing the plates in a strong solution of alum and water, the best results being obtained from a boiling solution, which rapidly converts the steel into rust, while it does not attack the brass plate.

Ammonia, or spirits of hartshorn, of commerce is sold usually in the form of a colorless liquid known as aqua ammonia, which is obtained from the ammonical liquor which results from the distillation of coal for the manufacture of gas. Its properties are somewhat similar to those of soda, potash and other alkalies. It will restore the blue color of litmus paper which has been reddened by acid, and counteracts the strongest acids.

Ammonia Phosphate of commerce is a salt produced by the exact saturation of phosphoric acid with ammonia. It is very useful in baths for producing thick platinum deposits.

Ammonium Sulphide of commerce is a liquid produced by saturating ammonia with sulphuretted hydrogen gas. In combination with metals it rapidly forms sulphides and is used on silver for producing the black coating sometimes called oxidation, and is employed for bronzing metals.

Aqua Regia is a combination of 1 part nitric acid and 2 parts hydrochloric acid, and its strength greatly depends upon the degrees of strength of the two ingredients that form it, which vary in commerce considerably. It is the strongest solvent of metals, and the only one that dissolves gold and platinum.

Boric Acid is employed for decomposing the subsalts deposited in cyanide electro-baths, and for increasing the whiteness of silver alloys.

Borax of commerce is usually met with in the form of colorless crystals. When heated by means of the blow-pipe these crystals expand and finally run into a kind of glass which dissolves nearly all the metallic oxides, and on this account it is used as a flux in hard soldering. It is also used in assaying with blow-pipe, for destroying the sub-salts of silver formed in electro-plating baths, and for restoring the shade of defective gilding baths.

Chromic Acid is generally made by a combination of bichromate of potash and sulphuric acid. It is used to excite galvanic batteries and as an etching agent.

Hydrochloric Acid of commerce, is a mixture of the acid proper and water. The acid proper is gaseous, and is therefore combined with water. It is a by-product in the manufacture of soda.

Hydrofluoric Acid will dissolve nearly all the metals except silver, platinum and lead. It is a dangerous acid to handle unless you are thoroughly acquainted with its nature. It is used for etching on copper, enamel and glass.

Magnesia Calcine is calcined carbonate of magnesia, and is sold in commerce in the form of a white powder.

Nitric Acid, or aqua fortis, may be purchased of various colors and degrees of strength, and it dissolves most of the metals. As it is frequently used in a dilute state, it is well to remember that WATER SHOULD NEVER BE Poured INTO THE ACID, but rather POUR THE ACID IN A SMALL STREAM INTO THE WATER, stirring meantime with a glass rod. As this and other acids heat rapidly, it is well to place the vessel, while mixing, in another vessel filled with water.

Oxalic Acid of commerce is sold in the form of white crystals, and is very poisonous.

Potassium Cyanide of commerce is a colorless salt having an odor somewhat similar to prussic acid. It is highly poisonous. Solutions of potassium cyanide will dissolve metallic silver. It is used in electro-plating, and the plating is more or less effective, depending on the power of the solution of the salts to dissolve the cyanides of gold and silver.

Potassium Bicarbonate of commerce is a colorless crystal. This salt is soluble in tepid water.

Potassium Bitartrate, or tartar, is a salt produced from the crystals found on the sides of wine casks. When purified it is known as cream of tartar. It is acid, and is slightly soluble in water.

Potassium Hydroxide, or caustic potash of commerce, is sold in the form of small sticks, which must be kept in air-tight bottles.

Potassium Nitrate, or saltpetre, is used as a flux, and as it readily yields a portion of its oxygen to other bodies, it is used extensively for oxydizing metals.

Potassium Sulphide is a salt which in commerce is sold in brown masses, and is sometimes called liver of sulphur.

Prussic Acid, or hydrocyanic acid, should be used with the greatest care, as it is one of the most deadly substances used in the art. It may be distinguished by its smell, which resembles that of peach pits, apple seeds or bitter almonds, and, in fact, these substances owe their peculiar odor to the presence, in small quantities, of this acid. It is used for decomposing the alkaline carbonates formed in baths with cyanide of potassium, and for maintaining the strength of the hypophosphite of gold in immersion baths.

Sal-Ammoniac, or Chloride of Ammonium, is used as a flux in soldering tin and other metals in the form of a paste obtained by combining with sweet oil. It is also used in battery solutions in electroplating.

Sodium Bicarbonate corresponds in properties very closely with potassium bicarbonate.

Sodium Hydroxide of commerce is solid, in thick white masses, and is readily converted into carbonate of soda by the absorption of carbonic acid from the air.

Sodium Pyrophosphate of commerce is sold in the form of a white salt which is soluble in water.

Sodium Phosphate of commerce is usually sold in the form of crystals. It is used in hot electro-gilding baths.

Sulphuric Acid or oil of vitriol is a colorless, odorless fluid. Like nitric acid, it should be carefully mixed when diluting with water, and the same water-bath used.

Tartaric Acid of commerce is usually sold in the form of crystals and also in the form of a powder. Solutions of this acid should only be prepared for immediate use, as it readily decomposes.

ADAMS, J. C. Born in Preble, N. Y., October 7, 1834. As a watch factory organizer he has probably had more experience than any living man. He served a five years' apprenticeship to John H. Atkins, an old Liverpool watchmaker, then located in Elgin, Ill. After serving his apprenticeship he worked for two years as watchmaker for I. E. Spalding, Janesville, Wis. He was afterwards engaged in business in Elgin, the firm being known as G. B. & J. C. Adams. The partnership was dissolved at the end of two years, and he accepted a position in the watch department of Hoard & Hoes, Chicago. In 1861 he had the management



J. C. Adams. of the watch department of W. H. & C. Miller, the largest jewelry store in Chicago. In 1862 he was appointed time-keeper for the various roads centering in Chicago. In 1864, together with

Charles S. Moseley and P. S. Bartlett, he organized the Elgin Watch Company. In 1869, together with Paul Cornell, he organized the Cornell Watch Company of Grand Crossing, Ill. One of the movements made by this company bore his name. In 1869, together with Springfield capitalists, he organized the Illinois Watch Company. In 1874 he organized the Adams & Perry Manufacturing Company. In 1883 and 1884 he was in the employ of the Independent Watch Company of Fredonia, N. Y. In 1885 he organized the Peoria Watch Company of Peoria, Ill., and remained with that company until April 14, 1888. He is the inventor and patentee of the Adams System of Time Records, now used by nearly every western railroad.

ADENDUM CIRCLE. The distance or space between the pitch line of a gear and the circle touching the ends of the teeth.

ADHESION. Adhesion is the mutual attraction which two bodies have for one another, as attraction between the liquid and the substance of the vessel containing it. See also *Oil* and *Capillarity*. Saunier says that the working parts in contact with each other should separate by sliding action and not by a sudden drawing asunder in a direction perpendicular to their touching surfaces, as such an action would involve the inconvenience of variable resistances, depending on the greater or less adhesion or cohesion of these surfaces. The amount of adhesion between clean surfaces is difficult to determine and it is impossible to give its exact proportion. In the case of oiled surfaces the resistance due to adhesion is proportional to the extent of the surfaces in contact.

ADJUSTING ROD. A device for testing the pull of the main-spring.

ADJUSTMENT. The manipulation of the balance, its spring and staff, for the purpose of improving the time-keeping qualities of a watch. Three adjustments are usually employed for this purpose, viz.: positions, isochronism and compensation.

Adjustment to Positions. The manipulation of the hairspring and balance so that the movement keeps time in the different positions. In ordinary watches two positions are taken, viz.; pendant up or vertical and dial up or horizontal. In the finer grade of work adjustments are made in the quarters, that is, with 3 up and 9 up. This adjustment is a delicate and often a difficult operation and it is only by constant study and application that the watchmaker can hope for success. Several excellent essays on this subject are in print, among which may be mentioned *Modern Horology in Theory and Practice* and the *Watchmaker's Hand Book* by Claudius Saunier, the *Watch Adjuster's Manual* by Charles Edgar Fritts, and *Adjustments to Positions, Isochronism and Compensation*, published by G. K. Hazlitt & Co., Chicago. *Isochronal*

adjustments are thoroughly reviewed in an excellent little work by Moritz Immisch entitled Prize Essay on the Balance Spring. The object of timing or adjusting to positions is to ascertain how far a change of position modifies the compensation and isochronism and to verify the poising of the balance. Saunier says the balance can not possibly be accurately poised in all positions if the pivots and pivot holes are not perfectly round, and the poising will be modified with a change of temperature if the two arms do not act identically; as will be the case when the metals are not homogeneous, when one or both arms have been strained owing to want of skill on the part of the workman, or careless work, etc. After accurately timing in a vertical position with XII. up, make it go for twelve hours with VI. up and the same number of hours with III. and IX. up. Observe with care both the rates and the amplitude of the arcs and note them down. Assuming the pivots and pivot holes to be perfectly round and in good condition and that the poising of the balance has been previously tested with care by the ordinary means, if the variations in the four positions are slight the poising may be regarded as satisfactory. As a general, but not invariable rule, a loss in one position on the rate observed in the inverse position may be taken to indicate that the weight of the upper part of the balance is excessive when it does not vibrate through an arc of 360° or the lower part if the arcs of motion exceed this amount. Independently of the balance this loss may be occasioned by excessive friction of the pivots due to a too great pressure owing to the caliper being faulty, or to a distortion of the hairspring causing its center of gravity to lie out of the axis of the balance. If these influences become at all considerable their correction will be beyond the power of the isochronal hairspring, and indeed it will be impossible to counteract them. Changes in the rate on changing from the vertical to the horizontal position may also arise from the following causes: 1. The action of the escape wheel, which is different according as it tends to raise the balance staff or to force it laterally. 2. A hairspring that starts to one side and so displaces its center of gravity, a balance that is not well poised, pivots or pivot holes that are not perfectly round, faults which although of but little importance in the vertical position of the balance staff become serious when it is horizontal. 3. The more marked portion of the friction of the pivots may take place against substances of different degrees of hardness in the two cases, the end stones being frequently harder than the jewels. Saunier further says that satisfactory results will be obtained in most cases by employing the following methods, either separately or two or more together, according to the results of experiments or the rates, the experience and the judgment of the workman:

1. Flatten slightly the ends of the balance pivots so as to increase their radii of friction; when the watch is lying flat the friction will thus become greater,

2. Let the thickness of the jewel holes be no more than is absolutely necessary. It is sometimes thought sufficient to chamfer the jewel hole so as to reduce the surface on which friction occurs; but this does not quite meet the case since an appreciable column of oil is maintained against the pivot.

3. Reduce the diameters of the pivots, of course changing the jewel holes. The resistance due to friction, when the watch is vertical, increases rapidly with any increase in the diameters of pivots.

4. Let the hairspring be accurately centered, or it must usually be so placed that the lateral pull tends to lift the balance when the watch is hanging vertical. In this and the next succeeding case it would sometimes be advantageous to be able to change the point at which it is fixed, but this is seldom possible.

5. Replace the hair-spring by one that is longer or shorter but of the same strength; this is with a view to increase or diminish the lateral pressure in accordance with the explanation given in the last paragraph.

6. Set the escapement so that the strongest impulse corresponds with the greatest resistance of the balance.

7. Replace the balance. A balance that is much too heavy renders the timing for positions impossible.

8. Lastly, when these methods are inapplicable or insufficient there only remains the very common practice of throwing the balance out of poise.

Adjustment to Isochronism. The manipulation of the hair-spring so that the long and short arcs of the balance are performed in the same time. The theory of isochronism advanced by Dr. Robert Hooke and more commonly known as Hooke's law, "as the tension so is the force," is an axiom in mechanics with which everybody is, or should be familiar. This law has like nearly all others its exceptions, and it is only partially true as applied to hair-springs of watches; "otherwise," says Glasgow, "every spring would be isochronous." Pierre Le Roy says that there is in every spring, of a sufficient extent, a certain length where all the vibrations, long or short, great or small, are isochronous, and that this length being secured, if you shorten the spring the great vibrations will be quicker than the small ones; if, on the contrary, it is lengthened, the small arcs will be performed in less time than the great ones. Glasgow says that a hair-spring of whatever form to be isochronous must satisfy the following conditions: Its center of gravity must always be on the axis of the balance, and it must expand and contract in the vibrations concentrically with that axis. When these conditions are secured in a properly made spring it will possess the quality of isochronism, that is, its force will increase in proportion to the tension, and it will not exert any lateral pressure on the pivots.

Britten says, it should be remembered that if the vibrations of a balance are to be isochronous the impulse must be delivered in the middle of its vibration, and that therefore no spring will be satisfactory if the escapement is defective in this particular.

The recognized authorities conflict considerably in their various theories in regard to adjustment to isochronism and particularly in regard to the length of spring. Inmisch says that mere length has nothing to do with isochronism. Glasgow contends that length has everything to do with it, and that a spring too short, whatever its form, would make the short arcs of the balance vibration be performed in a less time than the long arcs, and a spring too long would have just the contrary effect. Charles Frodsham advanced the theory that every length of spring has its isochronous point. Britten declares the length is all important; that a good length of spring for one variety of escapement is entirely unfitted for another variety. Saunier says that the discussion of the question whether short springs are preferable to long ones is a mere waste of

time and can result in no good. In horology everything must be relative. Whatever be the escapement under consideration, it requires neither a long nor a short hairspring, but one that is suited to its nature and mode of action, that is to say, the length must bear a definite relation to the extent of the arcs of vibration, etc.

Owing to the conflict of opinion it is advisable that the student read the various arguments set forth in the works referred to above and form his own conclusions.

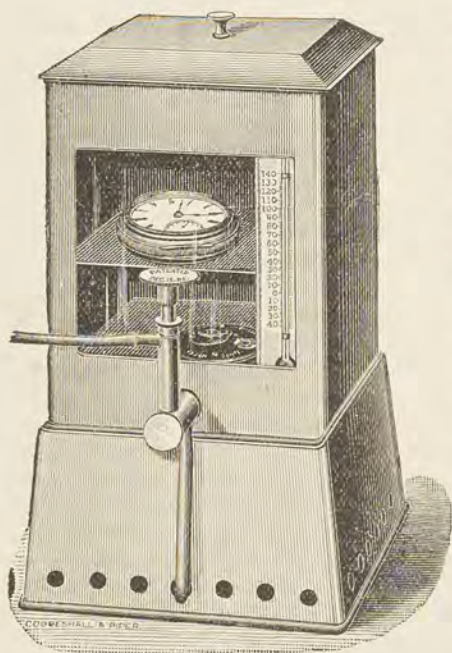

Fig. 2.

ing movements to temperature. The variation of temperature in this heater is one and one-half degrees in twenty-four hours. It is designed

ADJUSTMENT HEATER. The Simpson heater, shown in Fig. 2, will be found invaluable when adjust-

to be heated by gas, the cost of heating being but about three cents in twenty-four hours. A small lamp can be used if the watchmaker has no gas at command.

ALARM. The mechanism attached to a timepiece by which at any desired time a hammer strikes rapidly on a bell for several seconds. Generally a weight or spring actuates an escape wheel, to the pallet staff of which a hammer is fixed to act on a bell. The alarm is usually set off by a wire attached to the hour wheel lifting a detent that stops the escape wheel.

ALCOHOL OR BENZINE CUP. The watchmaker should keep the alcohol and benzine on his bench in a glass cup having a tight fitting cover to prevent evaporation and contamination with dust. It also adds to the appearance of his bench and is a great improvement over an old saucer and bottle. The cup shown in Fig. 3 has a ground glass cover or stopper that fits tightly into the neck of the cup.



Fig. 3.

ALCOHOL LAMP. The Clark patent simplicity lamp shown in Fig. 4 is a favorite one with American watchmakers. It has nine facets on the font that it may readily be adjusted to any required position. The wicks of alcohol lamps should not be too tight, and the interior and exterior of the font should be kept free from dirt. The Clark lamp should not be filled more than one-third full. The wick should be removed when it gets so short that it fails to reach well down into the alcohol.



Fig. 4.

ALL OR NOTHING PIECE. That part of a repeating watch that keeps the quarter rack off the snail until the slide in the band of the case is pushed around. The lifting piece of the hour hammer is kept free from the twelve-toothed ratchet, while the quarter rack is locked, so that the hours cannot be struck until the quarter rack has fallen. It is sometimes called the hooking spring. It was invented by Julien Le Roy.

ALLOY. A compound of two or more metals. It is usual to melt the less fusible metal first and add the more fusible.

Alloys for Compensation Balances. Breguet used for his compensation balances the following alloy: Silver, two parts, by weight; copper, two parts; zinc, one part. First melt the silver and throw in the zinc, reduced to small pieces, stirring the metals and leaving it on the fire for as short a time as possible to prevent the volatilization of the latter metal; then pour it out and let it get cold. Melt the copper and

add the cold alloy, stirring the three together until intimately mixed. Pour out, cut into pieces, and smelt anew, to obtain a perfect incorporation. Be careful, however, to leave the alloy as short a time as possible over the fire, because the zinc dissipates easily. This alloy is hard, elastic, very ductile, and quickly smelts in the furnace. It does not stand much hammering.

Alloy for Composition Files. These files, which are frequently used by watchmakers and other metal workers, for grinding and polishing, and the color of which resembles silver, are composed of 8 parts copper, 2 parts tin, 1 part zinc, 1 part lead. They are cast in forms and treated upon the grindstone; the metal is very hard, and therefore worked with difficulty with the file.

Aluminium Alloys. Aluminium is alloyed with many metals, but the most important are those with copper. Lange & Sons have obtained a patent in the United States for an alloy consisting of ninety-five parts of aluminium and five of copper, which is malleable and is used for clock springs. An alloy of ten parts of aluminium and ninety of copper is hard but nevertheless ductile. It takes a high polish and somewhat resembles gold.

Aluminium Bronze. This alloy contains from 6 to 10 per cent. of aluminium, and is prepared by fusing chemically-pure copper with aluminium. The standard bronze in use consists of ninety parts of copper to ten of aluminium. It gives sharp castings, is easier to work than steel, can be engraved, rolled into sheets or drawn into wire and when exposed to the air suffers less change than cast iron, steel, silver or brass. It can be soldered only with an aluminium alloy.

Aluminium Silver. Aluminium and silver are easily alloyed and these alloys are more easily worked than silver although harder. An alloy of ninety seven parts aluminium and three of silver is not affected by ammonium hydrosulphide and has a beautiful color. An alloy of ninety-five parts of aluminium and five of silver is white, elastic and hard. It is used for making blades of desert and fruit knives.

Aluminium Gold. One part of aluminium to 99 of gold gives a metal the color of green gold, very hard but not ductile. An alloy of 5 parts of aluminium to 95 parts of gold gives an alloy that is nearly as brittle as glass. An alloy of 10 parts of aluminium to 90 parts of gold is white, crystalline and brittle. An imitation of gold, used as a substitute for the precious metal in cheap jewelry, is made by fusing together 5 to 7½ parts of aluminium, 90 to 100 parts of copper and 2½ of gold. The color of this alloy resembles gold so closely as to almost defy detection.

COMPOSITION OF SOME VALUABLE ALLOYS.	Palladium.	Aluminium.	Gold.	Silver.	Bismuth.	Tin.	Zinc.	Lead.	Copper.	Antimony.	Iron.	Platinum.	Nickel.	Black Cobalt- ic Oxide.	Manganese.	Cadmium.
Alloy for Tea Pots.....	88.55	9.94	0.88	9.53
Alloy for Knives and Forks.....	10	1	100
Alloy for Opera Glasses.....	20	20	100
Alloy Resembling Silver.....	20	55
Alloy Resembling Silver.....	57
Alloy for Gongs and Bells.....	25	100	5	6.5
Alloy, Non-Magnetic.....	45 to 75	30 to 25	15 to 30
Bell Metal, American.....	11	39
Bell Metal, Japanese.....	5	3	1	2	10
Bronze, Japanese.....	4.86	1.86	9.9	82.72	0.55
Bronze, Manganesee.....	20	54.50	25.50
Bronze for Medals.....	50
Bronze for Ornaments.....	4	82
Bronze, Paris.....	18	2	50
Clock Bells, German.....	1.70	5.38	1.37	99.60
Clock Bells, Swiss.....	24.8	2.1	73
Clock Bells, French.....	1.44	25	5	74.5
Clock Wheels, Black Forest.....	26.56	72
For Spoons.....	1.36	36.88	60.66	74
Nurnburg Gold.....	7.5	2.5	25	50	25
Oreide.....	0.48	13.52	68.21	0.24
Prince's Metal.....	1	6
Pinchback.....	7	30	90
Soft Solder.....
White Metal.....	18	72	6	750	140	20	1

Alloys of Gold used by Jewelers.

COLOR.	GOLD.	SILVER.	COPPER.	CADMIUM.	STEEL.
Blue.....	250	-----	-----	-----	250
Blue.....	500	-----	-----	-----	250
Gray.....	800	-----	-----	-----	200
Gray.....	857	86	-----	-----	57
Gray.....	725	275	-----	-----	-----
Green.....	750	125	-----	125	-----
Green.....	750	166	-----	84	-----
Green.....	746	114	97	43	-----
Red.....	666	67	268	-----	-----
Red.....	750	104	146	-----	-----
Red, Pale.....	600	200	200	-----	-----
Red, Very.....	583	42	375	-----	-----
Yellow.....	583	250	167	-----	-----
Yellow.....	666	194	139	-----	-----
Yellow.....	750	146	104	-----	-----
Yellow, Dark.....	583	125	292	-----	-----
Yellow, Pale.....	666	333	-----	-----	-----

The alloys of gold should not be overheated and ought to be poured immediately after the proper fusion has taken place. The mixture should be well stirred from time to time after it has commenced to melt, using a cherry red iron rod, or a stick of very dry poplar or other slow burning wood. This serves two purposes; it makes the metal homogeneous in its composition and it enables the operator to judge by the feeling when the mass is thoroughly melted. As long as the metal feels curdy or cloggy, it is unfit to pour; when the stirred mass feels thin and watery it should be thoroughly agitated, fresh charcoal added, and allowed to stand for a minute, then poured.

In melting silver alloys, great care and strict attention to the points given below are necessary in order to secure homogeneous alloys of the proportions required. Especially is this the case when the alloys contain the more readily oxidizable metals, such as zinc and tin. The weighing of the metals, the arrangement of them in the crucible, the management during the time they are in the furnace, all are points requiring steady care and constant attention to produce accurate results.

When the alloy consists only of copper and silver they should both be put in the crucible before putting it in the furnace. Put the copper at the bottom and the silver over it, as copper has the highest melting point and the heat is greatest at the bottom; then, too, the silver being the heaviest, will descend through the copper when melting, thus producing a more perfect mixing than when the copper is placed on the top.

Alloys Resembling Silver. The following alloys have a close resemblance to silver: Minargent is composed of 100 parts copper; 70 nickel; 1 aluminium and 5 of tungstate of iron. Trabak metal is composed of tin 87.5, nickel 5.5, antimony 5 and bismuth 2. Warne metal is composed of tin 10, bismuth 7, nickel 7 and cobalt 3.

Aluminium Zinc. Alloys of aluminium and zinc are very hard and take a beautiful polish. An alloy of 97 parts of aluminium and 3 of zinc gives a result that is as white as the pure metal, harder than aluminium and very ductile.

Artificial Gold. A metallic alloy, at present very extensively used in France as a substitute for gold is composed of: Pure copper, 100 parts; zinc, or preferably tin, 17 parts; magnesia, 6 parts; sal-ammoniac, 3 to 6 parts; quicklime, $\frac{1}{8}$ part; tartar of commerce, 9 parts, are mixed as follows: The copper is first melted, and the magnesia, sal-ammoniac, lime and tartar are then added separately and by degrees, in the form of powder; the whole is now briskly stirred for about one-half hour, so as to mix thoroughly, and then the zinc is added in small grains by throwing it on the surface and stirring until it is entirely fused; the crucible is then covered and fusion is maintained for about 35 minutes. The surface is then skimmed and the alloy ready for coating. It has a fine grain, is malleable, and takes a splendid polish. It does not corrode readily, and is an excellent substitute for gold for many purposes. When tarnished, its brilliancy can be restored by a little acidulated water. If tin be employed instead of zinc, the alloy will be more brilliant.

Bell Metal. An alloy of copper and tin, in proportions varying from 66 to 80 per cent. of copper and the balance of tin.

Brass. An alloy consisting of about 65 parts of copper to 35 parts of zinc. This proportion is varied according to the uses to which the alloy is to be put. See *Bronzing, Plating and Coloring Metals*.

Brittania. This alloy as prepared by Koller consists of 85.72 parts of tin, 10.34 of antimony, 0.78 of copper and 2.91 of zinc.

Chrysolite. This alloy is sometimes used for watch cases and parts of the movement. In color it closely resembles 18 to 20 carat gold. It does not tarnish when exposed to the air and has a beautiful luster. It consists of 100 parts of copper and 50 of zinc.

Fictitious Silver. No. 1: Silver, 1 oz.; nickel, 1 oz., 11 dwts.; copper, 2 oz. 9 dwts.; No. 2, silver 3 oz.; nickel, 1 oz. 11 dwts.; copper, 2 oz. 9 dwts.; spelter 10 dwts.

Malleable Brass. A malleable brass is obtained by alloying 33 parts of copper and 25 parts zinc; the copper is first thrown into the pot, which is covered slightly and fused. As soon as the copper is smelted, the zinc, to be free from sulphur, is added, and cast into ingots.

Aluminium. Aluminium, or aluminum, is an extremely light, ductile and malleable metal, which is rapidly coming into favor for many purposes since the great improvements in its manufacture and the consequent reduction in cost. It can now be purchased in quantities at ninety

cents per pound, which makes it nearly as cheap as copper, when the great difference in weight of a cubic foot of the two metals is considered. It is silvery in appearance, melts at 1,300 degrees F., has a specific gravity of 2.56 to 2.60, which is one-fourth the weight of silver, does not oxidize readily and resists most acids and alkalis, but is very easily attacked by others, especially when heated, or when present during chemical reactions on other metals. It is three times as ductile as silver, and has 50 per cent. more tenacity or strength. Much nonsense has been written about this metal, such as that it is stronger than steel; will not rust; is not attacked by acids, etc., all of which are untrue. It is readily attacked by many chlorides, such as common salt (chloride of sodium), etc., and by some of the organic acids, in which respect it resembles silver. In regard to the hardening, tempering, etc., of the pure metal, comparatively little is known at present; but it is probable that as its use becomes more common it will be greatly improved in these respects, as has been done with iron. At all events, it will have an extended trial in the fine arts and mechanics, and it will probably displace platinum and nickel in the various alloys to some extent, on account of the great difference in weight. One great difficulty remaining to be overcome is that of soldering. At present it can be soldered only by using an alloy of which aluminium forms a part.

Aluminium forms alloys with many metals; those with copper, silver and tin are largely employed for many purposes, and their use is rapidly extending. The most important are those of copper, with which aluminium easily unites. See *Alloys*.

AMALGAM. A compound of mercury with another metal; as an amalgam of tin.

AMPLITUDE. The full extent or breadth. As applied to pendulums, the amplitude of a simple oscillation or vibration; properly the distance from the middle to the extremity of an oscillation, but the term is usually applied to the distance from one extremity of the swing to the other.

ANCHOR ESCAPEMENT. This form of escapement is mostly used in clocks, although in the older watches a variety of lever escapement was also known as the anchor escapement and was so called because of the resemblance of the earliest forms to a ship's anchor. The variety of forms in this escapement are innumerable, and include both the dead beat and recoil escapements. Like many other inventions in horology, neither the inventor nor the date of this escapement is known with certainty, the two claimants for the honor being Hooke and Clement, the latter a London clockmaker, in the years 1675 to 1680.

The imperfect escapement in use at the time of the application

of the pendulum to clocks was the source of much annoyance and the clockmaker was constantly on the alert for an escapement which would give to the pendulum a more nearly isochronous vibration,

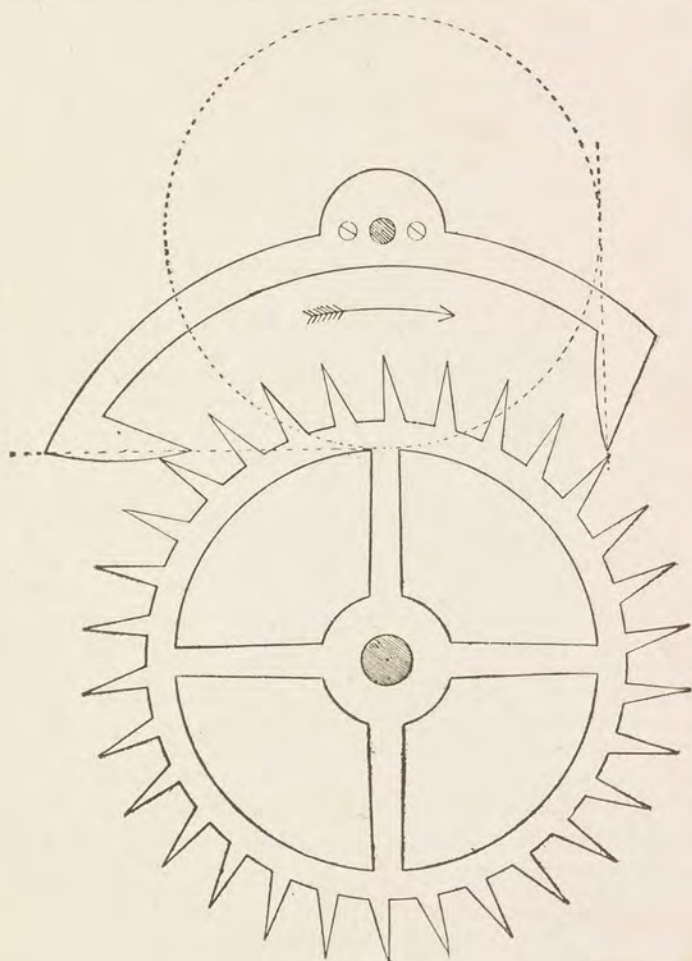

Fig. 5.

with the result of the invention of the anchor escapement, which remains practically the same at the present day. There are clock-makers who believe that the recoil escapement is preferable to the

dead beat escapement, but this is not a fact, if proper care is given to every detail of both the designing and the execution of the work.

The recoil escapement was made to overcome inequalities in the motive force, for with this form the pendulum was not so sensitive to a change in the motive power as in the dead-beat escapement.

There is a form of clock escapement made which is a combination of the dead-beat and recoil, being dead-beat on one pallet and recoil on the other, and from this circumstance are known as half dead-beat or half recoil escapements.

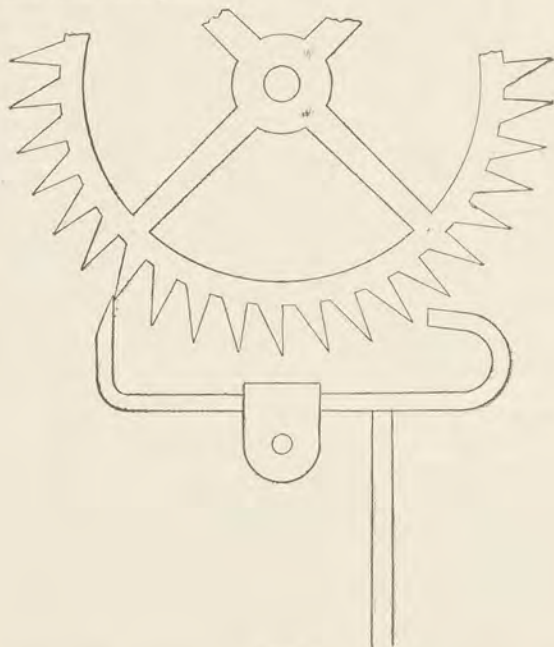

Fig. 6.

Fig. 6 illustrates a form of anchor escapement which is extensively used in American clocks.

Laying Out the Escapement. In laying out the escapement we must first determine the size of the escape wheel and also the number of teeth it is to have. We will make our drawing larger than the actual work is to be, and then after taking our measurements direct from the drawing, reduce them to the actual working size. In Fig. 5 the diameter of the escape wheel is three inches and has thirty teeth revolving to the right, so that we may mount a seconds hand upon the arbor if used with a seconds pendulum. In making a draft

of any kind all the lines should first be drawn in with a lead pencil, and then those lines which are to remain are to be inked in with any good waterproof India ink, Higgins' American drawing ink being an excellent article for the purpose. With the dividers set with a radius of one and one-half inches, draw a circle which will represent the diameter of escape wheel. The distance between one tooth and the next equals three hundred and sixty degrees (the number in a complete circle) divided by thirty, the number of teeth in our escape wheel, which will give us twelve degrees as the required distance ($360 \div 30 = 12$). The distance between the center of the escape wheel and the center of the anchor equals the radius of the escape wheel plus four tenths of this radius, $1\frac{1}{2} = \frac{3}{2}$, $\frac{4}{10}$ of $\frac{3}{2} = \frac{6}{10}$ and $\frac{3}{2} + \frac{6}{10} = \frac{21}{10} = 2\frac{1}{10}$ the distance required. This distance is to be increased or diminished inversely according as it is desired to reduce or increase the oscillation of the pendulum. Draw a line joining the center of the anchor and the center of the escape wheel, which is the center line of the escapement. In laying off the teeth begin at this center line, laying them off on either side until completed. The back of the teeth are to be radial, while the front faces are to be of an angle sufficiently great to give the teeth strength, yet not so great that more than the point of the tooth will at any time strike the pallet. When this angle has been decided upon, draw a line representing the front face of a tooth and extend it beyond the center of the escape wheel. Now draw a circle to which this line will be a tangent, and all that is necessary in order to draw in the rest of the teeth is to place the straight edge so as to coincide with the point of a tooth and this circle. From the center of the anchor draw a circle of a radius equal to half the distance between the anchor and escape wheel centers. As the anchor is to embrace eight teeth, we draw lines which are tangent to this circle, and touching the points of the fourth tooth on each side of the center one, which will give the pallet faces, if they were left flat. By curving the faces of the pallet and giving an angle to the front faces of the teeth, the friction is disengaging, consequently will wear better. This escapement is sometimes made to embrace ten teeth instead of eight.

ANGULAR GEARING. Toothed wheels of irregular outline, used in transmitting variable motion, as shown in Fig. 7.

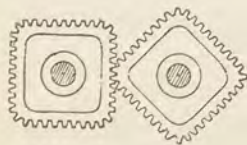

Fig. 7.

ANGULAR VELOCITY. The angle through which an arm turning on its axis is displaced in a unit of time. It is entirely independent of the length of this arm. The approximate ratio of the angular velocities of

the balance with the cylinder and (pocket) chronometer escapements in the same unit of time (one-fifth second when there are 18,000 vibrations per hour), is about $270^{\circ} : 360^{\circ}$. The velocity, properly so called, is the space transversed in a unit of time by the point under consideration (which in this case is taken on the circumference of gyration). For a given angular movement we obtain the approximate ratio of the velocities by multiplying each radius by the number of vibrations in a unit of time.—*Saunier*.

ANNEALING. The process of heating metals and then manipulating them in order to increase their ductility. Gold, silver, copper and brass are annealed by heating them to redness and then plunging them in water, while steel is annealed by heating and then allowing it to cool slowly.

ANNULAR GEAR. A gear wheel in which the teeth are on the inside of an annulus or ring, while its pinion works within its pitch circle, turning in the same direction.

ANODE. The positive pole of an electric current, that pole at which the current enters; opposed to cathode, the point at which it departs.

ARBOR. An axle or spindle on which a wheel turns.

ARC. Any given part of the circumference of a circle, or other curve.

ARCOGRAPH. An instrument sometimes used by watchmakers for drawing a circular arc without the use of a central point.

ARNOLD, JOHN. Born in Cornwall, England, in 1744, and died at Eltham, England, in 1799. He was the inventor of the helical form of balance spring and a chronometer escapement. The English Government awarded him £1,320 for the superiority of his chronometers in 1799, and his son, who followed up the successes of his father, was awarded £1,680 in 1805.



John Arnold.

ASSAY. To subject an ore, alloy or metallic compound to chemical examination in order to determine the amount of a particular metal contained in it.

AUXILIARY. See *Balance*.

BALANCE. The wheel in a watch, clock or chronometer which is kept in vibration by means of the escapement and which regulates the motion of the train. The size and weight of a balance are important

factors in the time-keeping qualities of a watch, although the dimensions of a balance are not criteria of the time in which the balance will vibrate. The balance is to a pocket time-piece what the pendulum is to a clock; although there are two essential points of difference. The time of vibration of a pendulum is unaffected by its mass, because every increase in that direction carries with it a proportional influence of gravity; but if we add to the mass of the balance we add nothing to the strength of the hairspring, but add to its load and therefore the vibrations become slower. Again, a pendulum of a given length, as long as it is kept at the same distance from the earth's center, will vibrate in the same time because the gravity is always the same; but the irregularity in the force of the hairspring produces a like result in the vibration of the balance. Britten says there are three factors upon which the time of the vibration of the balance depends:

1. The weight, or rather the mass, of the balance.*
2. The distance of its center of gyration from the center of motion, or to speak roughly, the diameter of the balance. From these two factors the moment of inertia may be deducted.
3. The strength of the hair-spring, or more strictly its power to resist change of form.

Balances are of two kinds, known as plain or uncut, and cut or compensation. The plain balance is only used in this country on the very cheapest variety of movements. The compensation balance is used on the better grades of watches. The plain balance is usually made of brass or steel, while the compensation balance is made of steel and brass combined. Some English makers use gold for plain balances, it being denser than steel and not liable to rust or become magnetized. The process of compensation balance making as carried on in our American factories is as follows: A steel disc, one-eighth of an inch thick and five-eighths of an inch in diameter, is first punched from a sheet of metal. It is then centered and partially drilled through, the indentation serving as a guide in the operation to follow. A capsule of pure copper three-fourths of an inch in diameter is then made, and in the center of this capsule the steel disc is lightly secured. A ring of brass one-sixteenth of an inch in thickness is then made and placed between the copper capsule and the blank, and the whole is fused together. It is then faced upon both sides. It is then placed in a lathe and cut away in the center until a ring is formed of steel, which is lined or framed with brass. It then goes into the press, where two crescents are cut from it, leaving only the inner lining of the ring and the cross-bar of steel. The burr is then removed and the balance is ready to be drilled and tapped for the balance screws. This method of making balances is known as the "capsule method."

*The mass of a body is the amount of matter contained in that body, and is the same irrespective of the distance of the body from the center of the earth. But its weight, which is mass X gravity, varies in different latitudes.

The Expansion and Contraction of Balances. The American Waltham Watch Company use a simple little contrivance shown at Fig. 9 for indicating the expansion and contraction of balances. It is composed of a steel disc, on one side of which a scale is etched and opposite the scale a hole is drilled and tapped to receive the screw that holds the balance. One of the screws of the balance to be tested is removed and the indicating needle is screwed in its place. The steel disc is held by means of a pair of sliding tongs over an alcohol lamp, or can be heated in any other way, and the expansion will be indicated by the movement of the needle on the scale. Figs. 10, 11 and 12 illustrate the expansion and contraction of balances. With an increase of temperature the rim is bent inward, thus reducing the size of the balance. This is owing to the fact that brass expands more than steel, and in endeavoring to expand it, bends the rim inward. The action is, of course, reversed by lowering the temperature below normal. Some adjusters spin a balance close to the flame of a lamp before using, in order to subject it to a higher temperature than it is likely to meet in use. The balance is then placed upon a cold iron plate and afterward tested for

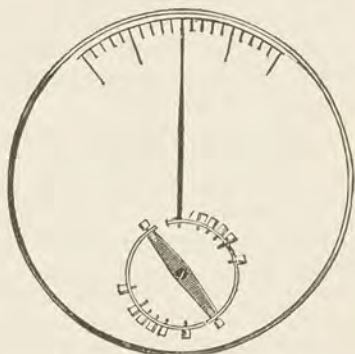

Fig. 9.



Fig. 10.



Fig. 11.



Fig. 12.

Original Position of Rim.

Under Extreme Cold.

Under Extreme Heat.

poise. The balance is then trued if found necessary, and the operation is repeated until it is found to be in poise after heating. Sir G. B. Airy, who has devoted much time to experiments with the compensation balance, declares that when heated the loss from

the weakening of the balance spring is uniformly in proportion to the increase of the temperature. The compensation balance does not meet the temperature error exactly, for with a decrease of temperature the rims expand a trifle too much and the contraction is not sufficient with the increase of temperature, and for this reason it is only possible to correct an adjustment in a watch at two points. Watches are usually adjusted at 50° and 85° , unless they are intended for shipment to very hot climates, when a higher point is selected. Marine chronometers, however, are usually adjusted at about 45° and 90° , but where intended for use on ships in the tropics, due allowance is made and a higher degree selected. Of course the rule is reversed where watches or chronometers are adjusted for use in the arctic regions. Under ordinary circumstances there would be a middle temperature error, with a steel hairspring, of two seconds in twenty-four hours.

In temperatures below normal the balance is larger in diameter, and the arc of vibration is less than it would be in a temperature above normal when the balance is smaller in diameter and the arc large, and its time of vibration is also effected by the hairspring so that it is not possible to predict with certainty the amount of middle temperature error. Watches are sometimes purposely left fast in the short arcs in order to lessen the middle temperature error and thereby take advantage of the above circumstances. Numerous forms of compensation balances and auxiliaries have been devised in order to try and counteract for the middle temperature error. Most of them, however, are utterly valueless. For a fuller description see *Compensation Balance*.

Sizes and Weights of Balances. The size and weight of the balance are two very important elements in the timing of a watch and especially in adjusting to positions. The rules governing the sizes and weights of balances, says Mr. Chas. Reiss, are of a complex nature, and though positive, are difficult of application on account of the impracticability of determining the value of the elements on which we have to base our calculations. These elements are the main-spring or motive power, the hairspring representing the force of gravity on the pendulum, momentum and friction. The relation of the motive power, or the mainspring, to the subject under discussion lies first in the necessary proportion between it and the amount of tension of the spring to be overcome, according to extent and number of vibrations aimed at; and, second, to that of friction affecting motion of the balance and incidental to it. In an 18,000 train the main-spring has to overcome resistance of the hairspring for 432,000 vibrations daily. The hairspring, having its force established by the relative force of the motive power, circumscribes the

proportions of the mass called balance and is a co-agent for overcoming friction.

Momentum overcomes some of the elastic force of the spring and friction. It is the force of a body in motion and is equal to the weight of the body multiplied by its velocity. Velocity in a balance is represented by its circumference, a *given point* in which travels a *given distance* in a *given time*. Weight is that contained in its rim. A balance is said to have more or less momentum, in proportion as it retains force imparted to it by impulsion. If a watch has a balance with which it has been brought to time, and this is changed to one-half the size, it requires to be four times as heavy, because its weight is then only half the distance from the center, and any given point in its circumference has only half the distance to travel. On the other hand, a balance twice the size, would have one-fourth the weight. In the first case the balance would have twice as much momentum as the original one, because if we multiply the weight by the velocity we have a product twice as great. In the latter case a like operation would give a product half as great as in the original balance.

It follows that the smaller and heavier a balance the more momentum, and, vice versa, the less momentum it has, always on condition that the hairspring controls both equally. Friction, affecting the vibration of the balance, is that of the pivots on which it moves and that of the escapement. It is in proportion to the force with which two surfaces are pressed together and their area. In a balance, weight is synonymous with pressure. Area is represented by the size of its pivots and the thickness of the pivot holes. The first, pivot friction, is continuous and incidental and is overcome by combined forces, the motive power, the elasticity of the hair-spring, and the momentum of the balance. The latter, or escapement friction, is intermitting and is overcome by contending forces, the hair-spring and the momentum of the balance on one side and the motive power on the other.

Having in our power, as shown above, to obtain the desired momentum of the balance by differing relative pressure and diameter, we can regulate pivot friction within certain limits and distribute the labor of overcoming it, among the co-operative forces, in such a manner that the proportions of such distributions shall not be disturbed during their (forces) increase or decrease. Incidental pivot friction is that caused by the unlocking on the impulse. The first causes retardation, the latter acceleration in the motion of the balance, regardless of isochronism. It is easy to comprehend that a heavy balance would, by its greater momentum, unlock the escapement with less retardation than a light one; but, on the other hand, the acceleration by the impulse would be less also; and with a varying motive power a disturbing element would be introduced by a change in the relative proportions of these forces, the momentum of the balance decreasing or increasing faster than the motive

power, constituting as it does relatively a more variable force. In argument the reverse of this might be advanced in regard to a balance which is too light. Without, however, entering further into the subject it is plain how the rate of a watch under such conditions might be affected after being apparently adjusted in stationary positions, by being used on a locomotive or under conditions where external disturbances should lessen the extent of vibration, and making the contact between the balance and the escapement of less duration.

The almost universal abandonment of watches with uniform motive power and the introduction of stem-winders with going barrels, invest the subject with special interest; and, as stated in the beginning, applying rules for defining these desirable proportions being impracticable, the only solution of the problem which remains to us is the study, by observation of certain symptoms which do exist, to determine that which by other means cannot be done. During the progress of horology, similar difficulties had to be met in every kind of watch which happened to be in use. The old Verge watch had its balance proportioned thus: that it could lie inside in the main-spring barrel, and the watch, when set going without a balance spring, would indicate, by the hand on the dial, a progress of twenty-seven and one-half minutes during one hour running. It was said that under these circumstances it would be least affected by inequalities of the motive power, and the verge would not be cut by the escape wheel. The balance in the Cylinder watch was to be sized according to the proportion of the train, each successive wheel to be one-half smaller than the preceding one, and the balance to be twice the size of the escape wheel, the weight to be determined by the equal running of the watch during all the changes of an unequal motive power. The cutting of the steel pallets in Duplex watches or chronometers is caused more by too heavy balances than by any other defect in their parts. It might be well to note the following which is very important and too often neglected. That is the arrangement of the mainspring in the barrel so as to avoid coil friction. The smallest advantage of the old Fusee watch was not the facility of obtaining five turns of the fusee to three or three and one-half of the mainspring, but being enabled thereby to arrange the latter around a small arbor in such a manner that the coils never touched, insuring a smooth motive power and lessening the chances of breakage beyond estimation.

Poising the Balance. In merely poising a balance for a cheap movement there is no great difficulty, that is, putting it in equipoise sufficient for the reasonably good performance of the movement; but to well and thoroughly poise for a high grade of movement embraces means and methods not necessary in the first mentioned. In a cheap balance a high degree of accuracy is not expected, and so the manipulations are, in the poising, simple, provided all the parts are in condition

to admit of poising. The following will be about all the conditions and means used generally: In the outset the balance should be in poise without its staff, and this is approximated before the staff is in by putting into the staff socket in the arm a piece of true wire, sufficiently tight to allow of the balance being held onto it with friction, so that the balance can be trued in the flat by the fingers or with tweezers and remain while poising on the parallel bars.

Fig. 13 illustrates a form of tweezers made especially for balance truing. To here explain the parallel bars and give a few points regarding the essential features will be well, and help to make clear some

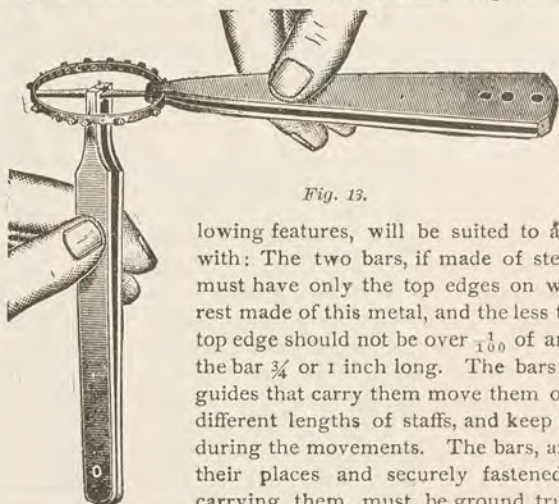

Fig. 13.

points that follow in the poising instructions. The parallel bars for the use of watch repairers with the following features, will be suited to all the cases met with: The two bars, if made of steel, for instance, must have only the top edges on which the pivots rest made of this metal, and the less the better. The top edge should not be over $\frac{1}{100}$ of an inch thick and the bar $\frac{3}{4}$ or 1 inch long. The bars must have the guides that carry them open or shut for different lengths of staffs, and keep the bars parallel during the movements. The bars, after they are in their places and securely fastened to the stand carrying them, must be ground true, straight and parallel, on a flat piece of glass (plate glass is the best), charged with emery of about 140, with oil sufficient to make a paste. The glass can be held and used as a file or the bars can be held down on the glass and moved about with a circular stroke, but if the stand is large and heavy this operation will not be readily performed with good results. The main reason for using the glass referred to, is that it is a ready way of getting a grinding bed comparatively true without labor or preparation. A flat metal surface, marble or stoneware, would answer well, but would not be so readily had. After the emery has ground the surface true, clean off all the emery and use fine oil stone powder or pumice stone; clean, and follow the pumice stone with any polishing powder, or follow the pumice stone with a large and true burnishing file, keeping the surface wet slightly. In making the parallel edges, the object is to give them a perfectly straight surface on the edge and highly polished. These parallels are probably best made of bell metal, as there is then no danger of their being affected or accumulating

magnetism. In the construction of a poising tool, to avoid the use of iron or steel in its make-up, will be found the most satisfactory, as then magnetism will not be a disturbing element that it might otherwise be. The whole tool should be heavy and low and stand on the bench firmly, and, if a fine one, have two level vials set in its base to level up the parallels with, before using. With a level bench and a tool made so that the feet are parallel to the top edge of the parallels, there will be little trouble in the balance rolling by gravity while poising. There are a great variety of poising tools, and any that have the parallel bars true and straight and parallel to one another, readily adjusted for distance, and have a firm and heavy stand, will be easily and satisfactorily handled.

Holes for the staff pivots are not good for poising, although jeweled, as the pivots must turn in them with a slipping action, whereas they roll without slip or friction on the parallels. The extreme top edge of the parallels, if of hard substance, can be made as thin as the $\frac{1}{200}$ of an inch and be all the better, as will be explained. The plain, straight portion of a conical pivot of a fine staff is frequently not over the $\frac{1}{100}$ of an inch long, and this is the part of the pivot that is to be exactly concentric with the center of gravity of the balance after poising is accomplished and is that part of the pivot that rests on the jewel. Now, from this it will be seen that the thickness of the parallels can not be great, not over the $\frac{1}{200}$ of an inch, as the conical part of the pivot must not touch the parallel, and the end of the pivot should be outside of the parallel. Fig. 14 will show the situation and give the best idea. After the balance has been trued on the wire, then test on the straight edge, and if the balance rolls freely and gravitates, then lighten it on the down or heavy side. Or in the event that the balance is rather light it may be advisable to weight it on the top or light side.

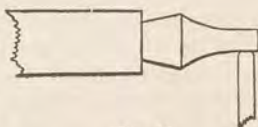

Fig. 14.

It will take a little practice to poise in this first operation, and there are several points to look at. First, if the balance is a heavy one, then in poising take away weight; second, if a plain (not comp.), remove little bits from the under side of the rim with a graver or drill; if very light, add weight by drilling in the rim and driving in several pins and then filing away till poised. The pins must be put into the rim at such points as are indicated by the circumstances. Soft solder, if used on the under side of a plain balance, is very easily handled, but the risk from the soldering fluid is great and requires great care in cleaning, but when all is well done, it serves a good purpose. As the wire on which the balance is hung is large in diameter, the poising will not be very delicate, but can be made good enough for the end served. In poising a compensating balance, the balance must be hung

on a wire with each end pointed, turned to points, so that the wire can be held in the calipers and the balance made true in the round.* Set the gauge of the calipers so that the rim at the end of one arm shall exactly coincide with it, and then turn the balance slowly under the gauge and see if the rim turns truly under it. If not true, bend in or out with the fingers and try by gauge till the balance will turn true in the round, then put onto the parallels and poise as in case of the plain balance, but alter the weight with the screws. The screws that are at the bottom can be put into a split chuck and a little turned away from the under side of the head, or a washer† can be put under the head of the top screw, and this method pursued till a reasonably fine poising is obtained. In these operations all the points relating should be well considered, and not make moves without method and good reasons. Care is required all through poising in all its branches.

These washers are very convenient to use in cases where a balance requires a little more weight, and where it is not advisable to change the hairspring or regulator when regulating to time, and in such cases must be put under the heads of the screws at the ends of the arms. All things being equal, in poising a weighted balance, it is better to add a little weight than to take away any, by turning the heads of screws as described, and then the balance is not in any way injured, and if it was all correct when found, although indications led to other conclusions, by removing a washer or two the balance would be left as originally, and much trouble saved in trying to remedy a mistake. Never make any changes in a fine compensated balance, as, in all probability, it was correct when made and some injudicious handling is to blame for any defect. After a balance has been trued in the calipers as described, so that the rim is truly concentric with the hole in the arm, it should, if it has not been injured, be virtually in poise, but if it is not, add washers to the screws on the light side, and by them try to poise it rather than by lessening the weight. Many times, taking a screw from the heavy side and putting it in place of one on the light, and the light in place of the heavy, will tend to an equilibrium, and so far as it does, is so much gain. In removing the screws in a compensating balance, care must be used when they are replaced, to see that they are left just tight enough to stay in place, and at the same time not bind the head hard down on the rim. Screws badly handled in this respect may derange the compensation, also the poising. All the screws of a balance, except those at the ends of the arms, and occasionally a pair of the quarters, should be down, heads close to the rim. The others can be turned in and out at pleasure to poise, or for timing, as required. With a balance with a screw at each end of the arm, it is best not to move them in or out in poising, but proceed as described and leave these screws to be moved in timing afterward,

*See *Gauges*.

†See *Balance Screw Washers*,

if required, as it helps to make that operation easy. When a balance has four screws they may be moved to do all the poising and afterward any pair opposite, or the whole, may be moved in timing and not disturb the poising. A compensating balance with four screws as described is much the easiest balance to handle, for by these screws the finer adjustments in poising and timing can be easily performed with greater certainty than by the old methods as described.

The balance staff is a very important element in poising and its pivots should be perfect, that is, perfect cylinders, and all that part that touches the hole jewel should be of equal diameter. By referring to cut of staff, it will be seen that the end after leaving the cone is straight, of equal diameter throughout its whole length, and this is the shape of all staff pivots at that point riding in the jewel holes, no matter what curve or shape may be given to the balance of the pivot. When there is a different diameter in the top and bottom pivots they are each true cylinders and their cylindrical diameters are parallel to each other and to the axis of the staff. When pivots are bent, or out of parallel with the axis of the staff, they are then not in condition to make poising possible, as a bent pivot will make a balance gravitate and act as though out of poise in itself, and with a bent pivot, poising can only be approximately attained. Perfectly cylindrical and parallel pivots to a staff are, in poising, a very essential feature, and without which poising cannot be attained.

When a balance has been poised as indicated and a staff made and fitted with perfectly cylindrical and parallel pivots, proceed as follows, and there will be little to do to complete the operation: First put the balance on the staff with a hollow punch and only press it on sufficiently to hold for preliminary tests; then place on the parallels of the poiser and examine; should the balance appear in poise, it must not be taken for granted that it is so, but try a very slight jar given the poising tool, like rubbing over the frame an old file, which will impart to it a very slight vibration, and if the balance is actually out, it will roll and then remain with the heavy side down. If a jar, such as a series of taps with a hammer, be given, the balance will rotate and stop for an instant and then rotate again, and finally jar off the bars and the operation will not prove anything. The jar is such that the balance raises up bodily, when made with a file, and then falls down exactly on the same place on the parallels, rather the pivots come to rest always at the same point; and it will be seen by this means that if any point of the rim is in reality heavier from gravity, that it will by the momentum imparted, fall, overcoming the pivot friction, and finally seek a point in a direct line under the staff.

Repeated movements of a balance while on the parallels are necessary, together with great cleanliness of pivots and parallels, to thoroughly ascertain the true poised condition of the balance. When it is ascertained that a balance is out of poise or has a heavy side, punch out the staff and put the balance again on it only turned just one-half way around,

and repeat as above. In this way a staff can be put into a balance to the best advantage and such little items all tend to save time and make easy the whole handling. When the best position is found for the staff, stake it, and true in the flat, and test again on the bars, and if necessary make further changes as above to affect a poise. When a balance is in poise and a staff perfectly true as has been described, and well staked on, it will in the most cases be found poised and nothing further to do. After putting on the roller it is advisable to test again for position, but it is generally unnecessary, as this will not disturb the poising only in exceptional cases. By staking on the roller too tight the staff may be bent and may destroy the poise.

Care is necessary in handling a balance for any purpose, not to bend the rim, soil or corrode the metal and finish, and in making slight alterations in the curve of the rim, not to bend it at the holes and so destroy its true circle and injure the strength of the metal and change its adjustment.

Any one, after poising a balance and testing the movement carefully in different positions, will in many cases be aware of quite a change of rate in the changes of position, and this, at the first thought, would seem to rather reflect on the accuracy of the poising; but it will be found to occur at times with the most carefully poised balance, and that the operation of poising by the parallels does not comprehend the whole, nor the very nicer requirements. In any case the most careful mechanical poising must be attended to first, before any operations of a more delicate nature are attempted. In short, the parallels are to be used in the most delicate methods, but precede the others. When a movement is placed in its case and hung up, after poising on the parallels, its rate should be carefully noted for a given time, then it should be just reversed and set up with the pendent down, when it will be found, as a rule, that after a trial of same duration as the first, that the rate will not be the same. Now, when this occurs in a fine movement, it will be advisable to investigate all the parts which in any way relate to this action. Both hole jewels must be examined, for finish, thickness and truth of the bore; the roller jewel and the lever-fork examined; guard pin and its action with the table; the hairspring and all its relations and connections; the balance must be removed and then the lever, and the lever placed on the parallels by its staff pivots, as in the balance, and tested for poising. The lever should, when placed on the parallels, lay horizontal, like the beam of pan scales, and not swing or hang either end down; the weight should be removed from the heavy end, in such an event, until the lever will lie as indicated. Levers can be, and are made, that will stand in any position, like a poised balance, but it will, in most cases, be difficult to poise a lever for any position other than horizontal. Next, the escape wheel must be poised so that it will perform as a poised balance, when on the parallels; lever and escape jewels examined, as in those of the balance staff.

After all has been so far attended to, and the parts in place again, the balance must stand, when the mainspring is entirely run down, with its arms either perpendicular or horizontal; with a movement, whose balance is near the center, the arms can stand pointing to 6 and 12, or 3 and 9, as the most convenient. In requiring balance arms to stand in some fixed relation to prominent points of the movement, the manipulations are greatly facilitated, though any position the arms may chance to have will not interfere with the result, but a more expert hand will be required to get along with ease and certainty.

When all the foregoing operations are attended to, hang up the watch and take its rate for 12 hours, with main spring fully wound up; then reverse its position, with main spring wound up, and test for another 12 hours. On examination, if there should be any considerable variation in the rates in the two positions, say 10 to 15 seconds, then proceed by changing the screws as follows: in a case where the watch loses when hanging, it indicates that a screw of the balance nearest to 12 or 6, when the movement is entirely run down, must be moved a very little in or out. In this case, it is fair to suppose that the balance is too heavy on the side nearest 6—that this side gravitates, and, to an extent, acts like a pendulum. Assuming this to be the case, turn the lower screw in and the upper one out, where there are four timing screws, and, where not, washers may be added to the top screws, and the two trials repeated. After trial, if the result is improved, then the lower screw may be made a little lighter, but not at the first trial. In the first trials the balance should not be altered in weight, as indications in these manipulations are changed or modified by conditions not yet mentioned.

We will assume that the balance has four screws, and when one is turned in and the other out, as indicated, and the end attained, then the watch is to be placed with the 3 or 9 up, and two trials made, as in the first, and the same method used, if indications are similar.

When the handling of the balance has been correctly done, the poising will be found to equalize the rates of the different positions, and the total performance improved. There are, of course, many chances for mistakes, but, with caution, they will do no harm, for if the balance is not changed other than a change in distribution of its weights, the act of restoring will be merely setting all the screws back to the position they were when poised by the parallels, and then proceed again on a new method, reversing the first; and then gradually it will be made clear to the most inexperienced, remembering that what held good in one case may not in another; and that various cases are only compassed by trial; and that the indications in the one may be just reversed in the other.

Instead of changing the lower screw as previously suggested, another trial may be made with 12 down, and the rate taken for the same period as for 6 down, and the two compared. Now if the watch maintains its

former record it is pretty good evidence that the two rates will be its rates for these two positions, and then the alterations may be made. Now, while hanging in this case the watch lost, 6 down, and relatively gained with 12 up, and a very natural conclusion would be, if losing with 6 down, that the lower side of the balance would be the heaviest. Such is not the case, but the indications are that the upper side is the heaviest, and that the screw there should be turned in, and that the lower one may or may not be changed. Change the top screw first, in this case, and then make another trial and compare with the first. In all average cases, after changing the screw, the two rates should be found to be closer than in the first trial, and this will give a pretty good index of how to proceed. The philosophy of the action is the same as that of the action of the musical measuring instrument used to beat music measures, called a metronome. It has a short pendulum with the rod prolonged above the shaft that it swings on, and on the upper end of this rod is a small weight that slides up and down and so regulates the beats. The position of this weight, being above the center of motion, has a very great control of the vibrations and controls them for a wide range. For instance, the whole pendulum of one of these instruments is not over 2 or 2 ½ inches long, but with the little counter weight it can be made to beat seconds and slower measures, which could not be accomplished with anything short of a 39 inch pendulum and over. Then move the screw as already indicated, keeping in mind the compared pendulum action and its philosophy.

Gravitating on the principle of the simple pendulum is not the whole problem in moving the screws of the balance, but they embrace the philosophy of the instrument described, and this must be kept in mind in the handling. In experiments it will be found that a screw moved at at the top of a balance, will make twice as much changing in the rate as the same movement of a screw at the bottom. Hang up a watch and turn out the lower screw one-half a turn, and the rate will be, for instance, ten seconds slow in six hours. Now put up just reversed, and for the next six hours the watch will be found twenty seconds slow or more. Now, if we proceed in this case on the simple pendulum philosophy, we should make a mistake in moving the screws.

In practice it is not necessary to make only tests for 3 and 9, assuming we have an open face watch. First regulate on full spring for 6 or eight hours hanging, and when well regulated place the watch 3 up and then 9 for the same period on full spring, and if any material change in rate is found in the two last, then move the screw as already indicated, keeping in mind the compound action and its philosophy.

The handling of the screws in poising on the parallels and in the running watch are for some indications just reversed, and this is due to the action of lever and hairspring on the balance, with gravity in one case and to gravity alone in the other. In experimenting with the running

watch always wind fully up for each trial, and periods of six to eight hours will be found the most convenient. The upper coils of a mainspring are much the most equal in power, and consequently give best results; that is, the fourth, fifth and sixth turns of a spring are much nearer each other in strength than are the second, third and fourth. If a balance is perfectly poised mechanically, and the whole train in perfect mechanical poise and condition, then the running watch should not give any very considerable difference in rate in four positions, but as this is not the case generally there will be a change of rate in the positions and the balance can be then manipulated to correct the error, although it in itself may not be at fault. The reason for not testing a watch for the whole range of four positions, is that in the pocket, a watch is not supposed to get into a position with the stem down, three and nine are apt to be up and down, and so with twelve are the three positions used. The isochronal condition of the hairspring is apt to make trouble in these experiments, and this is another reason for using full spring invariably. The extent of motion of the balance is another element in the matter, and any movement when in perfect poise for a balance motion of $\frac{3}{4}$ of a revolution, each side of the center or dead point ($1\frac{1}{2}$ revolution) would not be found in as accurate poise for $\frac{3}{4}$ of a revolution. A balance making one and a half revolutions, to a certain extent, is self-correcting, as will be seen, and is to be preferred to any other movement, for if any point of the rim is out of poise then the fault is brought just opposite in each excursion, and so does not relatively gravitate. Owing to the fusee, an English lever with a balance making one and one-half revolutions, is the highest form of movement for accurate adjustments of any kind and so is the easiest to realize perfect poising. The American watch is so uniformly well and evenly made by machinery that poising is in it quite easy, and much more so than in foreign makes. A Waltham movement that I tested, just as it left the factory, only changed its rate about three seconds for the four positions. This could not be realized in any medium grade of foreign watch, and I presume this is not a single case, but probably rather a type. The American movement is made mechanically so near perfection that the watchmaker will find poising a balance comparatively easy, and that what he finds to hold good in one case will be pretty sure in another, due to this mechanical perfection. J. L. F.

BALANCE ARC. That part of the vibration of a balance in which it is connected with the train, used only in reference to detached escapements.

BALANCE BRIDGE OR COCK. The standard that holds the top pivot of the balance in an upright position. In some of the old English and French full plate watches the balance cock was spread out to

cover the entire balance, as shown in Fig. 15, and was sometimes artistically wrought and set with precious stones.

BALANCE PROTECTOR. No matter how careful a person may be, accidents will happen, and the least accident to a compensation balance gives the workman considerable trouble. The Arrick patent balance protector, Fig. 16, is intended for guarding balances from contact



Fig. 15.



Fig. 16.

with turning tools, polishers and the hand rest, while work is being done upon the pivots. The staff is passed through the hole in the protector, and held in a wire chuck, and the protector is secured to the arms of



Fig. 17.

the balance by two screws. The Bullock protector, shown in Fig. 17, is designed to protect the balance and other wheels from heat while drawing the temper from staff or pinion for the purpose of pivoting.

BALANCE SCREW WASHERS. All watch adjusters and expert repairers time their watches by the balance screws, without unpinning the hairspring, and have their regulator in the center. After the curve of the hairspring is once correct, it should never be let out or taken up. The portion of the spring where it is pinned is naturally stiffer and often abruptly bent to make the first coil conform to the stud and regulator. In unpinning the spring this curve is necessarily altered and the spring thrown out of the center, the heat and cold adjustment is altered and the isochronal adjustment often entirely destroyed.

When a watch has timing or quarter screws and they move in or out friction tight, you can very soon bring your watch to time without

molesting the spring and have the regulator in the center, and also poise by these screws. Very often some of these timing screws are so tight that there is danger of twisting them off. You will also find that two-thirds of the watches of the best makes do not have timing screws. In this case time by a pair of screws opposite the balance arms. If it runs too slow lighten an opposite pair of screws (just mentioned) in a split chuck or file in the slot with slotting file. If it runs too fast put a pair of washers under the screws near the balance arms, or four at right angles or more under other screws. Whatever may be required in poisoning put the required amount on the light side of the balance rim. Do not tamper with an adjusted hair-spring or any other. If you are anxious to do your work quickly and accurately, compare your seconds hand with that of the regulator. See *Poising the Balance*.

BALANCE SPRING. See *Hair Spring*.

BALANCE STAFF. The axis or staff to which the balance is attached. In some makes of watches the balance staff and collet are one piece, while in others the collet is made of brass and is fitted tightly to the staff.

Making a New Staff. It is a very common thing for American workman, especially those who reside in the large cities, to depend upon the stock of the material dealer for their staffs. The country watchmaker must, however, rely upon his mechanical ability, and even in the large cities the workman will have to make his own staffs when repairing many foreign watches. The following instructions relate more particularly to staffs for American watches, though they may be applied to foreign watches as well. Before proceeding further I would call the attention of the trade to a most valuable series of essays on the balance staff, published in the columns of *The American Jeweler*, and would advise those interested to read them carefully*

The material used should be the best, say Stubb's steel wire, a little larger in diameter than the largest part of the staff and a trifle longer than the old one. A wire that fits the No. 45 hole in the pinion gauge will be about right in the majority of cases.

Put this in the split chuck of your lathe, if you use an American lathe, and rough it out to the form shown at *B* in Fig. 18. If you use a Swiss or wax chuck lathe, the form of chuck shown at *A*, Fig. 18, will be found very useful. † It is made from a piece of brass rod, threaded to fit the lathe spindle and bored out to receive

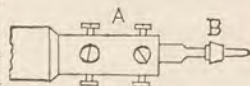

Fig. 18.

* Making and Replacing the Balance Staff, a series of seventeen essays published in *The American Jeweler* for December, 1888, and January to September, 1889, inclusive. The illustrations are from these essays.

† From the essay by "Pasadena," *American Jeweler* March, 1889.

the work, which is held by set screws, three or four at each end of the chuck. By the aid of these screws the work may be held very firmly and yet can easily be brought to center.

After bringing the work to the general form of the staff, in the rough, remove from the lathe, smear with soap and harden by heating to a cherry red and plunge endwise into oil. Re chuck in the lathe, and while revolving, whiten by applying a No. 000 emery buff, so that you may observe the color while drawing the temper. Now place the roughed-out blank in the bluing pan, and draw to a deep blue in color.

The heights may be taken from the old staff, providing it was not faulty and is at hand, but all things considered it is better to make your measurements and construct the new staff independent of the old one.

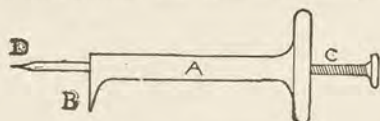

Fig. 19.

A simple tool, and one which any watchmaker can make, is shown in Fig. 19. It will be found very convenient in taking the measurements of heights of a staff.† It consists of a hollow sleeve *A*, terminating in a foot *B*. Through this is screwed the rod *C*, terminating in a pivot *D*, which is small enough to enter the smallest jewel. To ascertain the right height for the roller, place it upon the foot *B*, indicated in Fig. 20, and set the pivot of the tool in the foot jewel, and adjust the screw until the roller is in the proper relation to the lever fork as shown in the illustration. In Fig. 20 the potence and plate of the watch are shown in section at *A*. The roller is indicated at *c* and the lever fork at *d*. After the adjusting of the roller is completed, remove the tool and apply it to the rough staff as indicated in Fig. 21, at *A*, and the point at which the seat for the roller should be cut will be shown. In order to ascertain the height of the balance, apply the gauge as before and bring the point *e*, so as to give sufficient clearance below the plate as indicated by the dotted lines at *B*, Fig. 20. Then apply the gauge to the work as indicated at *B*, Fig. 21, and turn the

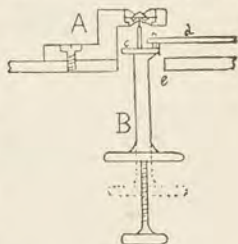
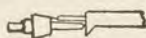
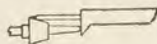

Fig. 20.



A



B

Fig. 21.

balance seat at the point indicated. The diameter of the seat for the roller, balance and hairspring collet, can be taken from the old staff,

† Other measuring instruments for this purpose will be found under *Gauges*.

or gauge the holes with a taper arbor or a round broach, and then take the size from the broach with calipers.

The diameter of the lower pivot should be taken from the jewel, and the ordinary pivot gauge, when used in connection with a round pivot broach, is all that is necessary even for the finest work. At *A*, in Fig. 22, is shown the gauge, each division of which corresponds to about $\frac{1}{2500}$ of an inch. Slip the jewel on the broach as far as it will go without forcing, as shown at *B*, Fig. 22, and then take the size of the broach, close up to the jewel, by means of the slit in the gauge. This will not give you the exact size of the jewel hole, but will be just enough smaller to allow of the proper freedom of the pivot.

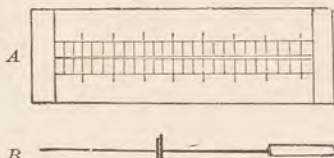

Fig. 22.

The best shape for the pivots is shown in Fig. 23, known as conical pivots; the straight portion of the pivot which enters the jewel hole being truly cylindrical and about $\frac{1}{10}$ of an inch long.

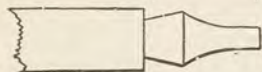

Fig. 23.

Many very good workmen employ but one graver for performing the entire work, but it is better to have at least three, similar in shape to those shown in Fig. 23; *A* for turning the staff down in the rough, *B* for under-cutting, and *C* for turning the conical shoulders of the pivots. A graver like that shown at *D* will be found excellent for beginners and others who find it difficult to hold the

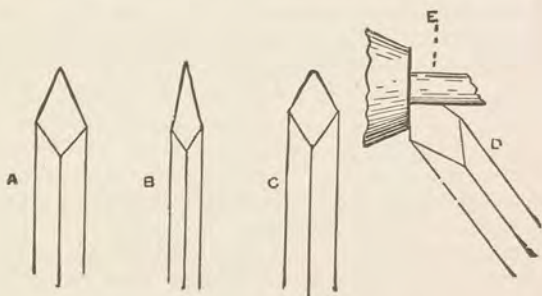

Fig. 24.

shoulder square and at right angles to the staff *E*, without leaving a groove in one or the other. The all important thing is to keep the gravers sharp. Upon the least sign of their not cutting, stop the work and sharpen them.

Next in importance is the position in which the graver is applied to the work. It must, under all circumstances, *cut* and not *scrape*. If held

as shown at *A*, Fig. 25, it will cut a clean shaving, while if applied as at *B*, it will only scrape. If held as shown at *C*, the force of the cut will be in the direction of the hand, as indicated by the arrow. If the point

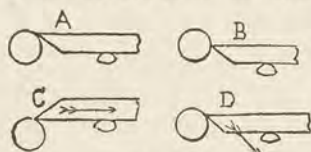

Fig. 25.

should catch from any cause, the hand would yield and no harm would be done, while if held as at *D*, the force of the cut would be downward upon the rest, as indicated by the arrow, and the rest being unyielding catching would be dangerous.

The roughing out should be done with the point of the graver held as at *C*, Fig. 25, and then finished with the edge held diagonally as at *A*, Fig. 26. It is difficult to show the exact position in the cuts, but the idea is to have the shavings come away in a spiral may be as fine as a hair, but in perfect coils.

To turn the pivot, hold the graver nearly in line with the axis of the lathe, as shown at *B*, Fig. 26, and catching a chip at the extreme end with the back edge of the graver, push forward and at the same time rolling the graver towards you, which will give the pivot the conical form. Very small pivots can be turned in this way with perfect safety, and very smoothly. Of course, this method of turning will not give sharp corners; such places as the seat of the roller, balance, etc., must be carefully done with the point of the graver.

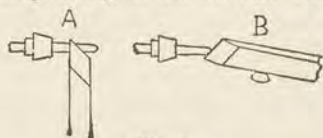

Fig. 26.

The pivot and seat of the roller should be left slightly larger than required, to allow for the grinding and polishing, the amount of which will depend upon how smoothly the turning is done. The grinding is done



Fig. 27.

with a slip of bell-metal or soft iron or steel of the shape shown at *A*, Fig. 27. *B* is a bell-metal polisher, and may also be made of box wood. *A* should be used with oil-stone powder and oil, and *B* with crocus and diamantine for polishing.

When the staff is finished from the lower pivot to the seat of the balance, the upper part should be roughed out nearly to size, then cut off, reversed in the lathe and the top part finished. It is better to do this in a wax chuck even if you use a split chuck, for the lower part of the staff is tapered and it is ten chances to one that you could select a split chuck that would hold it true and firm. In using a wax chuck the important point is to get a perfect center. It should be turned out with the graver at an angle of about 60° , care being taken not to leave a little "tit" in the center. Before setting the staff in the wax it is necessary to get its full length as follow: Screw the balance cock in place with both cap

jewels removed, and if the cock has been bent up or down, or punched to raise or lower it, see that it is straightened and put right; then with a degree gauge or calipers take the distance between the outer surfaces of the hole jewels, and shorten the staff with a file to that length.

A very handy tool can be made by adding a stop-screw to the common double calipers as shown in Fig. 28. The improvement is that they can be opened to remove from the work and closed again exactly the same.

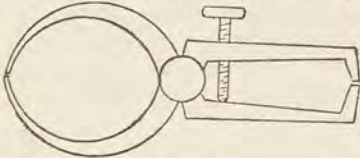

Fig. 28.

When fixing the staff in the chuck, care should be taken not

to burn the wax. Use a small lamp and heat the chuck until the wax will just become fluid. The staff should be set in the wax about to the seat of the balance, the finished pivot resting in the center of the chuck, and the outer end trued up by the finger and the point of a peg while the wax is still soft.

Fig. 29 shows it with the staff finished, but, of course, it is not, when put in the wax. The dotted lines show about the right quantity and shape of the wax, which must be true and round, or in cooling it will draw the work out of center. If necessary, when cool, the wax can be turned true with the graver, again heated and centered. The turning and finishing is to be done as previously described. The seat

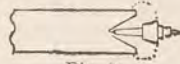

Fig. 29.

for the balance should be slightly undercut and fitted to drive on tightly without riveting. Take the size of the top pivot from its jewel the same as the lower. The ends of the pivots should be finished as flat as possible, and the corners slightly rounded. When done, remove from the wax and boil in alcohol to clean, and it is ready to receive the balance, which should first be poised as described on page 27.

BANKING. 1. The striking of the lever on the banking pins
2. The striking of the impulse pin on the lever, owing to excessive vibration. 3. The striking of the pin in the balance, in cylinder and verge watches, against the banking pin.

BANKING ERROR. When by a sudden circular motion of the watch in the plane of the balance (a very frequent occurrence when wearing the watch, or winding it up in a careless way), the vibration increases to more than two full turns, the impulse-pin strikes against the outside of the fork, which cannot yield, because it is leaning against the banking-pin or edge. By the violence of this percussion there is some danger of injury, not only to the ruby-pin, but also to the balance-pivots, which are often bent or broken by the reaction. But more than that, all such cases are accompanied by a considerable acceleration of the rate

of the watch, producing under unfavorable circumstances great differences in its time-keeping.

BANKING PINS. The two pins that limit the motion of the lever in the lever escapement, are known as banking pins. The pins used for limiting the motion of the balance in verge and horizontal escapements are also known as banking pins. The two pins in the balance arm which limit the motion of the balance spring in pocket chronometers are also known as banking pins.

BANKING SCREWS. 1. The two adjustable screws against which the lever banks. 2. In the chronometer escapement an adjustable screw by means of which the amount of locking of the escape tooth on the locking jewel is limited.

BARLEYS. The small, diamond shaped projections left after engine turning.

BARLOW, EDWARD. An English clergyman who is said to have invented the rack striking work for clocks. With this mechanism, which was invented in 1676, clocks could be made to repeat the hour at will, and this invention was quickly followed by the repeating watches of Quare. Both Barlow and Quare applied for patents on repeating watches and the English government finally decided in favor of the latter in 1687.

BAR MOVEMENT. A watch movement having no top plate, but in lieu thereof are bars, in which the upper pivots are carried. This is a favorite form among Swiss watch manufacturers and is used largely in Jurgenson and other fine repeaters. See Fig. 30.

BAROMETRIC ERROR. The error in a clock's rate due to changes in the density of the atmosphere through which the clock's pendulum has to move.

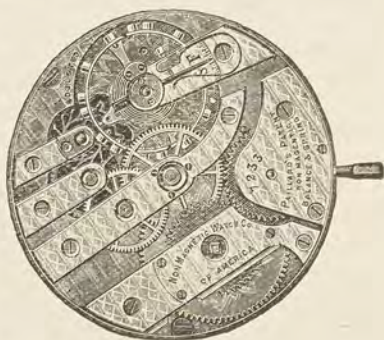

Fig. 30.

BARREL. A cylindrical box made of brass or steel in which the mainspring of a watch or clock is confined. Barrels are of two general types, those with and those without teeth around their circumference. In fuzee watches the power is conveyed to the fuzee by means of a chain and from the fuzee to the center pinion by means of the great wheel on the fuzee. In American watches the barrel has teeth cut upon its circumference and gears directly into the center pinion. The latter type is generally known as the "going barrel." The going barrel is again divided into two types, one which has a support at both ends of the arbor and the other which is supported only at the upper end by the ratchet wheel. This latter form, which is sometimes termed the overhanging barrel, is generally found in repeaters and complicated watches, where economy of space is found desirable. This type of barrel is objectionable even in the very best makes of watches on account of the undue friction of the ratchet wheel and its liability to become out of upright by even the smallest amount of wear. Where this style of barrel is used, the objections may, to a certain extent, be overcome by the use of a large ratchet wheel and superior fitting. Of late years steel has taken the place of brass for barrels very largely, especially among American makers, but these barrels do not find favor among repairers as it is very difficult to replace the mainspring hook when broken.

The barrel dates from about 1500, but is not as old as the mainspring, for there are many examples still in existence of antique watches which had no barrel proper. This is illustrated by a watch, which is in the collection of Mr. Carl Marfels, of Berlin. In this specimen the mainspring is confined within the limits of four iron pins, and the motion is conveyed to the train through the medium of the staff and a great wheel.

BARREL ARBOR. The barrel axis, around which the mainspring coils. M. Rose calls attention to the importance of the proper diameter of barrel arbors, and points out that if the arbor is too large part of the elastic reaction of the spring will be wasted, and if too small there will be a rupture or straining of the spring and therefore a loss of elastic reaction. It is, then, he says, the thickness of spring that determines the diameter of the arbor or conversely, and from this it follows that the diameter is not an arbitrary quantity, since it depends on the duration of flexion and thickness of spring. See *Mainsprings*.

BARREL CONTRACTOR. An instrument for contracting distorted mainspring barrels. It consists of a die with a series of tapered holes and punches to correspond. The barrel being forced into a hole slightly smaller than its circumference necessarily contracts.

BARREL HOOK. A hook in the barrel to which the mainspring is attached. The mainspring is sometimes attached by means of a hook on the spring which fit in a hole in the barrel.

BARREL RATCHET. A wheel which is placed on the barrel arbor and kept from turning backward, when the mainspring is wound, by a click or dog.

BARTLETT, P. S. The first ladies watch made in America was turned out by the American Waltham Watch Co., in 1861 and named the P. S. Bartlett. Previous to this however, in 1859 the company placed an 18 size movement on the market which was named the P. S. Bartlett, but its manufacture was discontinued in 1859. Mr. P. S. Bartlett, after whom these movements were named, was born in Amesbury, Mass., September 3, 1834. His first connection with watchmaking was in 1854, when he went to work for the Boston Watch Co., just after its removal to Waltham Mass., where he occupied the position of foreman of the plate and screw department. In 1864 he visited Chicago, and together with Messrs. Moseley, Adams and Blake, organized the National Watch Co., of Chicago, afterwards known as the Elgin National Watch Co. He subsequently signed a contract with the company for five years, as foreman of the plate and screw departments. He was for seven years assistant superintendent and general traveling agent for the company, during which time he introduced Elgin watches into Europe, selling them in Moscow, St. Petersburg and other large cities. He is now in the wholesale and retail watch and jewelry business in Elgin.

BASCULE ESCAPEMENT. A form of chronometer escapement in which the detent is mounted on a pivoted axis. It is also known as the pivoted detent escapement to distinguish it from the spring detent.

BEAT. The striking of the escape wheel upon the pallet or locking device. When an escapement is in adjustment, so that the striking of the escape wheel upon the pallets is even and equal it is said to be in beat and when it is not in adjustment it is said to be out of beat. The latter, says Saunier, may be due to any of the following causes: 1. One or even both of the pins that secure the hairspring in the collet and stud are loose. 2. The spring is strained between the two curb pins. 3. The Hairspring stud not having been placed immediately over the dot on the balance when putting the escapement together.

BEAT BLOCK. A device for obviating the necessity of marking the balance to see that it is in beat.

Before taking off the hair spring lay it on the block, turn the balance so the roller pin hits on the side the arrow points, then turn the table so that the line comes under the stud. In replacing the balance put the stud over the line and it will then beat the same as before. By using this tool you also avoid getting the balance out of true.



Fig. 31.

BEAT PINS. Small screws or pins to adjust the position of the crutch in relation to the pendulum. The pins at the end of the gravity arms that give impulse to the pendulum in a gravity escapement.

BELL METAL. See *Alloys*.

BENCH. An excellent arrangement for a watchmaker's bench is shown in Fig. 32. This bench was designed by G. W. Laughlin and is complete in every detail. Benches can be purchased ready made



Fig. 32

from almost any tool and material house in the country but many prefer to make their own or to have them made in order to vary the details to suit their peculiarities. The bench shown in Fig. 33 is one of the

latest designs on the market, the points claimed for it being that it is raised sufficiently from the ground to allow sweeping under it, its small

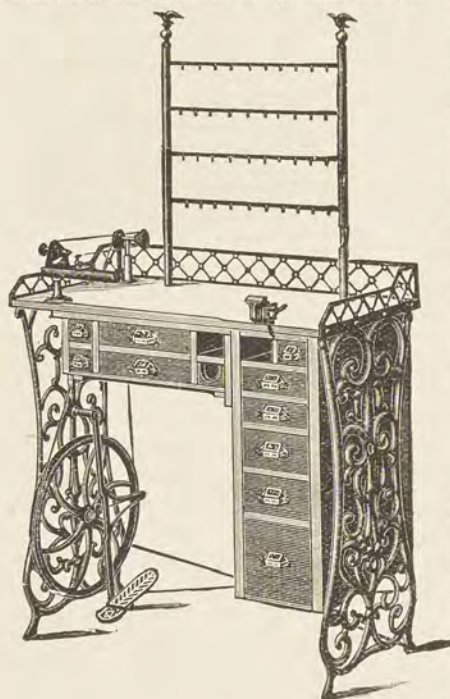

Fig. 33.

weight and its low price. The frame is made of iron and is similar to those used for sewing machines. The foot wheel is fastened to the iron frame on the left, instead of being supported by uprights from the floor. It is neat in appearance, substantial, and reasonable in price. From the sketch (Fig. 32) any first-class cabinet maker should be able to make a good bench. This bench is made of black walnut, veneered with French walnut and bird's eye maple. The top is twenty-one inches wide by forty-one long, and is thirty-three inches high. The drawers on the right hand side are ten inches wide. In the center are two drawers and the left hand side is entirely boxed in. The lathe wheel can be varied to suit the ideas of the watchmaker, a space of five inches being left for its reception. For the various styles see *Lathe Wheels*. Well seasoned black walnut, cherry or red cedar are the best woods for a bench. The little pin attached to the right hand side of the bench is a pegwood cutter, an enlarged view of which is shown in Fig. 34.

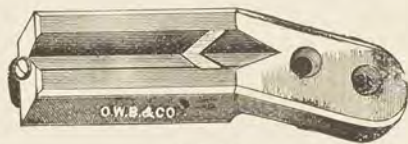

Fig. 34.

BENZINE. A light oil of petroleum used for cleaning movements. For directions for use see *Watch Cleaning*.

BERTHOUD, FERDINAND. A Swiss horologist who was born in 1729 and died in 1807. At the age of nineteen he visited Paris, never

afterward leaving it. Saunier says that "his technical training was matured and perfected by contact with the great masters of that day, of whom he subsequently became a rival. He was possessed of a very extensive knowledge and real talent, coupled with indefatigable energy; these are sufficient to explain and justify his great reputation. He published ten quarto volumes on horology. Berthoud did much valuable work, and his name will therefore long remain one of the glories of the horological art."

BERTHOUD, LOUIS. A French chronometer maker and nephew of Ferdinand Berthoud. He died in 1813.

BEVEL GEARS. Gears in which the two wheels working together stand at an angle to each other.

BEZEL. The grooved metal ring of a watch or clock that holds the crystal or glass in position.

BEZEL CHUCK. See *Chuck*.

BINDING WIRE. Fine malleable iron wire used for binding articles while soldering, etc.

BITE. To adhere to; to hold fast; as a set screw *bites* a shaft. The eating of metal by means of acid.

BLOWER. The form of bellows shown in Fig. 35 is known as the Fletcher Foot-Blower, and is applicable wherever an air-blast is required, either for the blow-pipe or for operating melting furnaces. It is simple compact, portable and powerful; giving a steady blast of air at a pressure of from one to nearly two pounds to the inch. Two patterns of this blower are made, one with the air reservoir on the top of the bellows, and the other like the one shown in the illustration. The latter form is preferable, as it obviates the risk of injury to the rubber reservoir or its net, by dropping tools or corrosive liquids upon them.

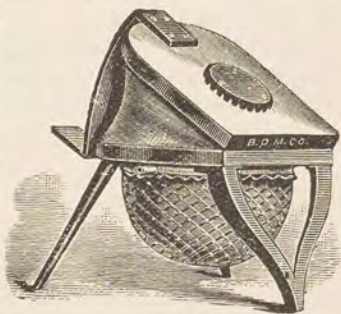

Fig. 35.

BLOW-PIPE. A tapering metal tube, used to direct the flame from a lamp or gas jet upon an article for soldering, annealing and similar purposes.

Fig 36 shows the automatic hand blow-pipe, which is used in connection with the foot-blower. One of the rubber tubes shown is connected to the blower and the other to the gas supply. It is self-adjusting, for



Fig. 36.

both gas and air, requiring only a slight motion of the lever, shown under the thumb, to obtain instantly any flame from the smallest to the largest. Fig. 37 shows Poppen's patent soldering blow-pipe lamp. In this lamp the flame is

made by igniting the fumes of the gasoline contained in the can and forced through the pipe, as shown in the illustration. Flame can be made any size. Unscrew top A, fill can one quarter with gasoline (this fluid gives best results), handle same as an ordinary blow-pipe. Blowing through pipe B causes the fluid

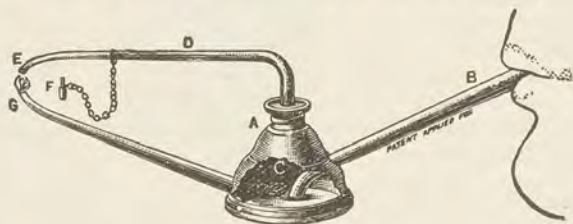

Fig. 37.

in C to bubble, which separates the fumes from the fluid and at the same time forces them through pipe D to outlet E, then light wick at pipe G. For a small flame insert pin F in outlet E, which is also inserted to preserve the strength of fluid while the blow pipe is not in use.

BLUESTONE. A soft blue stone, sometimes used for reducing brass and gold before polishing. It must not be confounded with blue vitriol, sometimes called bluestone.

BLUING. The changing of the color of steel by heat.

BLUING PAN. A pan used for bluing screws and other small articles. It is sometimes very desirable to match the color of screw heads in a watch. By making the following described simple little tool you can very readily color your screws straw, purple, or blue, as the case may require, to match the other screws in the watch. Select a very large mainspring barrel, drill a hole in the side of the barrel the size of an ordinary pendulum rod for an American clock, cut a thread in this

hole and also on the piece of wire and screw it firmly into the main-spring barrel, cutting off about four or five inches long, to which attach a neat piece of wood to serve as a handle. Now take out the head and fill the barrel full of fine marble dust or brass or iron filings and replace the head in the barrel, after which drill any number and size of holes in

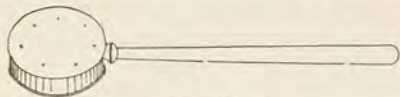

Fig. 38.

the barrel you wish, to accommodate all sizes of watch screws, and the tool is ready for use. Bluing pans, similar to the one shown in Fig. 38,

can be purchased from material dealers, and are similar to the one described. After fitting the screw to the proper place in the watch, harden and temper in the usual manner. Polish out all the scratches or other marks, and selecting a hole in the tool to fit the screw loosely, press it down level with the face of the barrel and hold the tool over a small alcohol lamp flame until the color desired appears. Heat up slowly and the effect will be much better than if it is done

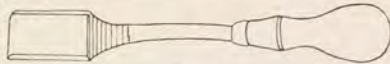

Fig. 39.

rapidly. First blue the screws without any special regard as to uniformity of color. Should they prove to be imperfect, take a piece of clean pith and whiten the surface with rouge, without letting it be too dry. Pieces when thus prepared, if cleaned and blued with care will assume a very uniform tint.

Soft screws are sometimes very difficult to blue evenly, but this difficulty may be overcome by finishing them with a slightly soapy burnisher. Bluing shovels, like that shown in Fig. 39, can be purchased from material dealers.

Pieces that are not flat will rarely assume an even color when placed in a flat pan. To overcome this difficulty, sprinkle the bottom of the pan with fine brass filings or marble dust and press the article into it. The bluing pan or shovel should be thoroughly warmed before the articles are placed in it, in order that any moisture present may be dispersed.

BOB. The metal weight at the bottom of the pendulum.

BOILING-OUT PAN. A copper or brass pan, which is also known under the name of pickle pan. It is used for boiling steel pieces in alcohol to remove shellac, and for boiling out



Fig. 40.

jewelry after soldering. For the latter purpose use sulphuric acid one part, and water fifteen to twenty parts.

The pan, which is shown at Fig. 40, will also be found useful for tempering small steel articles by boiling them in oil.

BORT. A collective name for diamonds of inferior quality, especially such as have a radiating crystalization, so that they will not take a polish. These are crushed to form diamond powder, or diamond dust, which is used for cutting and polishing diamonds and other precious stones; also the steel work of watches, and other instruments of precision.

BOTTOMING FILE. A file constructed like those shown in



Fig. 41.

Fig. 41, so that it may be used for filing sinks, or other depressions, where an ordinary file cannot be brought into use.

BOUCHON. A hard brass tubing sometimes inserted in watch and clock plates to form pivot holes, and known in America as bushing wire. See *Bushing*.

BOW. A device now obsolete, which consisted of a strip of whale-bone, to both ends of which a cord or gut was attached, and which was used to rotate a drill or mandril, before the introduction of watchmakers lathes.

The ring of a watch case, by which it is attached to the chain. See also *Pendant Bow*

Bow Tightener. See *Pendant Bow Tightener*.

BOW COMPASSES. A pair of compasses furnished with a bow pen for describing circles with ink. Fig.

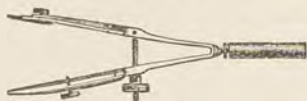

Fig. 42.

42 illustrates the ordinary form of these implements, although they are sometimes used in combination compasses, which are made to hold steel points and pencils as well.

BOW PEN. A metallic ruling pen, similar to the one attached to the bow compasses.

BOXWOOD. The fine, hard-grained timber of the box, much used by wood engravers, and in the manufacture of musical and mathematical instruments, etc. The wood is very free from gritty matter, and on that account its saw-dust is much used in cleaning jewelry, drying small polished articles, etc.

BRASS. An alloy, consisting of about 65 parts of copper to 35 parts of zinc. This proportion is varied, according to the uses to which the alloy is to be put.

Brass Polishes. 1. Rottenstone 4 oz., oxalic acid, powdered, 1 oz.; sweet oil, $1\frac{1}{2}$ oz.; turpentine to make a paste; apply with soft leather. 2. Equal parts of sulphur and chalk, made into a paste with vinegar. Allow to dry on the article and clean with a chamois brush. 3. Dip the brass in a mixture of 1 oz. alum, 1 pint lye, and polish with tripoli on a chamois. This gives a brilliant luster.

Magic Polish for Brass. Add to sulphuric acid half its bulk of bichromate of potash; dilute with an equal weight of water, and apply well to the brass; rinse it well immediately with water, wipe dry, and polish with pulverized rotten stone.

Polishing Paste for Brass. Dissolve 15 parts of oxalic acid in 120 parts of boiling water, and add 500 parts of pumice powder, 7 of oil of turpentine, 60 of soft soap, and 65 of fat oil. The polishing agent is usually mixed with oil, alcohol or water, to prevent scattering, and is then applied to the polishing tool in the shape of cloth and leather buffs, polishing files, etc. Either the work or the tool should revolve with great velocity, in order to secure good results. Many articles are brought to a high degree of polish, by the use of the burnisher, after subjecting them to the action of the ordinary polishing agents.

Etching Fluids for Brass. 1. Dissolve 6 parts chlorate of potash, 100 parts water, add 160 parts water to 16 of fuming nitric acid; mix the two solutions. 2. One part sulphuric acid, 8 parts water. 3. One part nitric acid, 8 parts water. 4. Nitric or sulphuric acid 1 part saturated solution of bichromate of potash 2 parts, water 5 parts.

Gold Yellow for Brass. A gold like appearance may be given to brass by the use of a fluid prepared by boiling for about 15 minutes, 4 parts caustic soda, 4 parts milk sugar, and 100 parts water, after which 4 parts of a concentrated solution of sulphate of copper is added with constant stirring. The mixture is then cooled to 79 degrees C., and the previously well cleaned articles are for a short time laid into it. When left in it for some time they will first assume a blueish and then a rainbow color.

Lacquers for Brass. 1. Dragon's blood 40 grains; seed lac 6 ounces; amber and copal, triturated in a mortar, 2 ounces; oriental saffron, 36 grains; alcohol 40 ounces; extract of red sanders $\frac{1}{2}$ dram; coarsely powdered glass 4 ounces. 2. Gamboge, seed lac, annatto, dragon's blood, each 1 ounce; $3\frac{1}{2}$ pints alcohol, $\frac{1}{4}$ ounce saffron.

Gold Lacquer for Brass. Twenty four grains extract red sanders wood in water, 60 grains dragon's blood, 2 ounces amber, 6 ounces seed lac, 2 ounces gamboge, 36 grains oriental saffron, 36 ounces pure alcohol, 4 ounces powdered glass. The amber, gamboge, glass, dragon's blood and lac should be thoroughly pounded together. Infuse the saffron and the sanders wood extract in the alcohol for 24 hours. Pour this over the other ingredients and strain.

Lacquer for Brass. Coat it with the following varnish; 1 part white shellac and 5 alcohol; 1 shellac, 1 mastic, 7 alcohol; or 2 sandarac, 8 shellac, 1 Venetian turpentine, 50 alcohol; or, 12 parts sandarac, 6 mastic, 2 elemi, 1 Venetian turpentine, 64 alcohol. Clean the article well, do not touch with your hands, and warm to about 75° C.

Blackening Brass. Dissolve pure copper in a mixture of nitric acid and water in the proportion of one part acid to four of water. Heat the article to be blackened over a Bunsen burner, dip it into the solution and again heat it over the flame. Upon the first application of heat the article will turn green, but this gives place in a few minutes to a dead black. On account of the heating this method cannot be employed for articles which have been soldered, although it is the very best for fine work of every description. Should a polished surface be preferable to a dead black, a coat of lacquer may be applied. For rough work, mix lampblack with gold size and apply with a soft brush. This mixture may be thinned with turpentine. If a gloss is desired add gold size, if a dull black add more lampblack.

BREGUET, ABRAHAM LOUIS. Born in Switzerland in 1747 and died in Paris in 1823. An eminent watchmaker of French parentage, and the inventor of the form of hairspring of that name. He was endowed with great ingenuity and a taste for complicated and remarkable mechanisms.

BREGUET SPRING. See *Hair Spring*.

BRIDGE. The standard secured to the plate, by means of screws, and in which a pivot works.

BROCOT SUSPENSION. The method of suspending a pendulum which is in use on nearly all mantel clocks of modern make, by means of which they may be regulated from the front of the dial by means of a key.

BROACH. A tapering piece of steel used for enlarging holes and made with from two to eight cutting edges. Some broaches are made without cutting edges and are called polishing broaches. They are used

for burnishing pivot holes. Care should be taken to see that the handles of your broaches are properly fitted so that they revolve truly. To test this, rest the points against the fingers of one hand and causing the handle to rotate by two fingers of the other hand and the broach itself should appear to remain true. Sealing wax answers the purpose as a handle for broaches very nicely, and the broach can be centered in it without much trouble. In the latter case hold the broach between two fingers with the handle downward, and rotate it while close to the flame of an alcohol lamp, so that the sealing wax forms a regular oblong handle. It is well to gently draw a piece of iron charged with rouge along the edges of pivot broaches in order to remove the thread of metal from them. Minute particles of this thread might otherwise remain in the holes, and occasion wear of the pivots.

To Broach a Hole Vertically. It is quite a serious thing for young watchmakers to broach a hole vertically, a hole in a plate, or that in a barrel, is seldom maintained at right angles to the surface, when they have occasion to employ a broach. They may be certain of success, however, by adopting the following method: Take a cork of a diameter rather less than that of the barrel or other object operated upon, and make a hole in the length of the cork through which the broach can be passed. When the cork has been turned quite true on its end and edge, the broach is passed through, and used to enlarge the hole; by pressing against the back of the cork, it is kept against the barrel, whereby the broach is maintained in a vertical position.

To Solder Broken Broaches. Steel broaches and other tools are soldered by cleaning well the parts broken, then dipping them into a solution of sulphate of copper, and soldering them with ordinary soft solder. The joint is a good one and will stand ordinary hard wear.

BRONZING. See *Electro-Plating, Bronzing and Staining.*

BUFF. A device for polishing or reducing metals. Emery buffs are round or square sticks on which emery paper or cloth is glued. They are used to reduce the surfaces of metal. Fig. 43 illustrates a ring buff used for polishing



Fig. 43.

the inside of rings, preferably used on a polishing lathe.

BULLSEYE. A thick watch resembling a bull's eye in shape. A term usually applied to old fashioned English verge watches.

BURNISHER. A polished steel or agate tool used for glossing the surface of metals. Fig. 44 is a jewel burnisher. The article to be burnished must be first freed from all scratches, for scratches would only be brought out more prominently by the use of the burnisher. The burnisher must be kept highly polished or you cannot expect to do good work with it. Saunier gives the following method of re-facing a burnisher: Prepare a dry smooth piece of wood, rather thick, and of a width equal to the length of the burnisher. On this board carefully glue a piece of emery paper of a fineness corresponding to the degree of cut



Fig. 44.

required, stretching it as even as possible, and turning the edges down towards the under side. Then lay the board on a firm smooth surface, resting a weight upon it, and allow it to dry. In using this lap, it is fixed or allowed to rest against the side of the bench; holding the burnisher with two hands at its extremities, the workman places himself at one end of the board, and draws the burnisher along it towards him, maintaining the surface quite flat and applying considerable pressure. On reaching the nearer end, raise it, and after again placing it on the furthest end, draw towards the body, and so on. By proceeding in this manner all risk of rounding the angle will be avoided.

BUSH. A perforated piece of metal let into a plate to receive the wear of pivots. See *Bouchon*.

Bushing Pivot Holes. The bush may be either a turned or tapped one. A bush is selected as small as the pivot will admit. Open the hole in the plate or cock and finish with a rat-tail file. Slightly taper the end of the bush with a fine file until it will fit the hole. With a knife score the bush just above the edge of the plate and press it firmly into the hole. Break off the bush at the point scored and drive it firmly into place by means of the bushing punch shown at Fig. 45, and you will find your bush is riveted firmly into the plate. Observe the endshake your pinion requires and make due allowance when finishing off your bushing. In bushing a plate, particularly where the bushing must be large, some watchmakers prefer to use a solid wire and drill the hole after fitting. If this method is followed be careful to see that you accurately center the work before drilling, and drill first with a small drill, subsequently passing through a larger one, or open up the hole by means of a small broach. It is always well to use bushing wire with a hole smaller than is ultimately required, and enlarging afterwards while the work is centered in the lathe. A tapped bushing is very firm, but

unless the threads are well made is apt to be out of center. The closing hole punch shown in Fig. 45 often obviates the use of a bushing, if skillfully used.

To Bush a Wheel. A watch will frequently stop because a wheel is improperly centered in itself, whereby one side will gear too deep, the other too shallow, into the pinion driven by it. Such a wheel likely is of the proper size and has good teeth, but the difficulty is its proper centering, when fitted to its pinion. The following will be found to be an easy way of correction. Take a piece of lead of about the thickness of a silver half dollar, and clip and file it round so that it will fit into one of the larger steps in a step chuck of an American lathe. Screw it fast into the lathe, and while revolving, center and drill a hole of about the size of a winding arbor. Then, with a graver, turn out a recess, the size and a trifle more than the thickness of the wheel, so that it will fit in exact, with its teeth touching the outside of the cut. Drive the wheel from its pinion, and broach out the center, so as to take a bush of sufficient length, which should be firmly riveted in and filed smooth on the lower side. Turn a small groove around the outside of the cut in the lead, crowd in the wheel, with a burnisher set as a gavel. This fixes the wheel perfectly true on the outside. Now center and drill, leaving a little to be turned with a fine polished graver, to fit the same pinion. Rivet on, and your wheel is all right.

BUSHING OR CLOSING HOLE PUNCH. This tool is very simple in construction and will be found very useful in repairing both watches and clocks. Fig. 45, Goeggel's Bushing and Closing Hole



Fig. 45.

Punch, consists of two counter-sunk steel punches, with a post in the lower punch. In using, fasten the lower punch in vise and place the work over it. They are made in various sizes for watches and clocks and are quite inexpensive.

BUSHING WIRE. Hard brass tubing for bushing the pivot holes of watches and clocks. This wire is kept by most material houses in the various sizes applicable to watch and clock work, and is put up in assorted sizes. See *Bouchon* and *Bush*.

BUTTING. The touching of the points of the teeth of two wheels acting with one another. It is caused by the wheels being planted incorrectly, or by pinions or wheels of improper size. See *Depthing Tool* and *Wheels and Pinions*.

CALIPERS. Compasses having two curved legs or fingers pivoted together and used either to measure the inside or outside diameter of bodies. Calipers are divided into two classes, known as inside and outside calipers. They are used by watchmakers for determining the diameter of staffs and pinions, for testing the truth of wheels, etc. Calipers are sometimes used in poising balances, the balance staff being centered between the points of the calipers. For this purpose a hole is drilled in the calipers and jewels are inserted. Thompson's jeweled calipers, shown in Fig. 46, have garnet jewels inserted in the points of the arms at one end, and hardened steel bearings in the other. The Euclid Double Calipers are



Fig. 46.

very useful tools, as they give on the lower limbs an inside measurement corresponding to the outside measurement of the upper limbs. By adding a stop screw to the common double calipers as shown in Fig. 47, a very handy tool can be made, as the tool can be opened and removed from the work and closed again exactly the same amount. See *Gauge*.

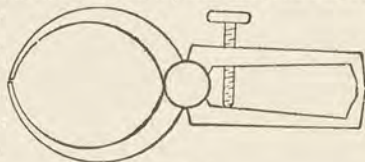

Fig. 47.

CALLET, F. A thorough mechanic and skilled calculator. He was born at Versailles, France, in 1744, and died in 1798.

CARBORUNDUM. A substitute for diamond powder, used in polishing. It is made in two grades. No. 1, which is an olive tinted powder, is used by lapidaries for polishing the facets of gems, as it is so much finer than diamond powder that a superior finish can be secured on the gem by its use. It is also much cheaper than diamond powder. No. 2 is a black powder, which resembles the other in hardness, but is impure and still cheaper. It has extensive use among metal workers as an abrasive. Both varieties are used by watchmakers in the various polishing operations, as substitutes for diamond powder, bort, diamantine, etc.

CAM. A moveable piece of irregular contour, so shaped as to give a variable motion to another piece pressing against it by sliding or rolling contact.

CANNON PINION. The pinion to which the minute hand is attached; so called on account of the pipe attachment resembling a cannon.

To Tighten a Cannon Pinion. The cannon pinion is sometimes too loose upon the center arbor. Grasp the arbor lightly with a pair of cutting nippers, and by a single turn of the nippers around the arbor, cut or raise a small thread thereon.

CAP. The part of the case that covers the movement. A thin metal cover used in some English, Swiss and German watches to cover the movement and attached by studs and a sliding bar or spring.

CAPILLARY ATTRACTION AND REPULSION. The cause which determines the ascent or descent of certain fluids when in contact with certain solid substances. See *Oil Sinks*.

CAPPED JEWEL. A jewel having an end stone as shown in Fig. 48. In all movements, except the cheapest grades, capped jewels are used for the balance pivots,



Fig. 48.

CARDINAL POINTS. The four intersections of the horizon with the meridian and the prime vertical circle, or North and South, East and West.

CARON, PETER AUGUSTUS. A celebrated French watch-maker, born January 25th, 1732, in the Rue St. Denis, Paris. When nineteen years of age he invented an escapement known in France as the double virgule, which may be said to be a combination of the cylinder and duplex. He disputed in 1753, with Lepaute, the honor of being the inventor, and was awarded the merit of the discovery by the Academy of Sciences, on February 24, 1754. At the age of twenty-five he obtained a situation at court, under Louis XV., and received permission, on giving up the watch business, to style himself Monsieur de Beaumar, and under this name he wrote and published two well known works, the "Barber of Seville" and "The Marriage of Figaro."

CARRIER. A piece fastened to work in a lathe and connecting it with the face plate. A dog.

CASE-HARDENING. A process of carbonizing the surface of wrought iron, thus converting it into steel. See *Steel*.

CASE SPRINGS. The springs in a watch case that cause it to fly open and that keep it in position when closed.

Adjustable Case Springs. The Harstrom Adjustable Case Spring shown in Fig. 49 is easily fitted and is said to be a very excellent spring. The holder should be fitted securely in a vice and with a three cornered



Fig. 49.

file cut down near the rear end on the back of the spring enough to rest a punch against; then with a tap of a hammer you can move it backwards. To move it forward, rest your punch against the end of the spring. Thus you can easily make it correspond with the screw hole in the case. Then, near to where it protrudes from the holder, bend the spring upward enough to make the front end level with the upper edge of holder, or move, if greater strength is required.

CASE SPRING VISE. The Boss case spring tool, shown in Fig.



Fig. 50.

50, is a very handy little tool. By turning the thumb screw you can bind the spring in the desired position and hold it there



Fig. 51.

until the screw is inserted in its proper place. It will be found much handier than the ordinary pleyer-shaped tools designed for the same purpose. Another form of case spring vise is Hall's, which is shown in Fig. 51.

CASE STAKE. A stake made with a large head, generally of steel, and used for taking out dents from battered watch cases. The

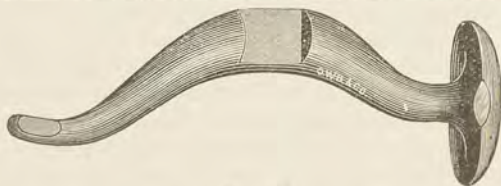

Fig. 52.

stake shown in Fig. 52 is of the reversible pattern, and while using is held in the vise.

CEMENTS. Cement for use in the lathe can be purchased from material dealers generally, at so small a cost that it will scarcely pay the watchmaker to bother in preparing it, but circumstances often arise where a cement is desirable for other purposes, such as attaching metal letters to show windows, etc., and the following recipes will be found very reliable:

Acid-Proof Cement. A cement that resists acid is made by melting one part India rubber with two parts linseed oil; add sufficient white bolus for consistency. Neither muriatic nor nitric acid attack it; it softens a little in heat, and its surface does not dry easily; which is produced by adding one-fifth part litharge.

Alabaster Cement. Melt alum and dip the fractured faces into it, then put them together as quickly as possible. Remove the exuding mass with a knife.

Alabaster Cement. 1. Finely powdered plaster of Paris made into a paste with water. 2. Melt rosin, or equal parts of yellow rosin and beeswax, then stir in half as much finely powdered plaster of Paris. The first is used to join and to fit together pieces of Alabaster or marble, or to mend broken plaster figures. The second is to join alabaster, marble, and other similar substances that will bear heating.

Amber Cement. For cementing amber and meerschaum, make a thick cream of finely powdered quicklime and white of egg, apply with a camel's hair brush, dry slowly and scrape off surplus after thoroughly dry.

Acid Proof Cement. Form a paste of powdered glass and a concentrated solution of silicate of soda.

Cement for Thin Metal Sheets. Cut isinglass into small pieces and dissolve in a little water at a moderate heat; add a small quantity of nitric acid, the quantity being determined by experiment; with too much acid the cement dries too slowly, while with too little it does not adhere well.

Cement for Glass and Brass. Melt together 1 part of wax and 5 parts of resin, and after melting stir in 1 part of burned ochre and $\frac{1}{4}$ part plaster of Paris. This is a good cement for attaching letters to windows. Apply warm to heated surfaces where possible.

Cement for Glass and Metals. The following cement is used extensively for fastening brass and enamel letters to show windows: Mix together boiled linseed oil, 5 parts; copal varnish, 15 parts; glue, 5 parts; and oil of turpentine, 5 parts; add to this solution 10 parts of slaked lime and thoroughly incorporated.

Cement for Knife and Fork Handles. Melt 2 parts of pitch and stir in 1 part of sand or brick dust; fill the cavity in the handle with the mixture, and push in the previously heated tang.

Cement for Paper and Metals. Dissolve dextrine in water, adding 20 parts of glycerine and 10 parts of glucose. Coat the paper with this mixture, and, after rubbing the metal with a piece of onion, attach the paper.

Engravers' Cement. Resin, 1 part; brick dust, 1 part; mix with heat.

Fireproof Cement. A very tenacious and fireproof cement for metals is said to be made by mixing pulverized asbestos with waterglass, to be had in any drug store; it is said to be steam tight, and resist any temperature.

Glass and Metal Cement. Brass letters, and other articles of a like nature, may be securely fastened on glass windows with the following: Litharge, 2 parts; white lead, 1 part; boiled linseed oil, 3 parts; gum copal, 1 part. Mix just before using; this forms a quickly drying and secure cement.

Gold and Silver Colored Cement. For filling hollow gold and silver articles. Consists of 60 parts shellac, 10 parts Venetian turpentine, and 3 parts gold bronze or silver bronze, as the case may be. The shellac is melted first, the turpentine is then added, and finally, with constant stirring the gold or silver bronze.

Jewelers' Cement. Put in a bottle 2 ounces of isinglass and 1 ounce of the best gum Arabic, cover them with proof spirits, cork loosely and place the bottle in a vessel of water, and boil it until a thorough solution is effected; then strain for use.

Metal Cement. Take plaster of Paris, and mix it to proper thickness by using water containing about one-fourth of gum Arabic. This cement is excellent for metal exposed to contact with alcohol, and for cementing metal to glass.

Strong Cement. Mix some finely powdered rice with cold water, so as to form a soft paste. Add boiling water, and finally boil the mixture in a pan for one or two minutes. A strong cement is thus obtained, of a white color, which can be used for many purposes.

Transparent Cement. A good transparent cement for fastening watch glasses, etc., in bezels or settings, is made by dissolving 7 parts of pure gum Arabic and 3 parts crystalized sugar in distilled water; the bottle containing the mixture should be placed in a utensil of hot water until the mixture assumes the consistency of syrup, and then left well corked for use.

Watchmakers' Cement or Wax. Eight ounces of gum shellac, heated and thoroughly incorporated with one-half ounce of ultramarine, makes the strongest and best wax for use on cement brasses and chucks.

CEMENT BRASSES. Attachments to a lathe to which work is fixed by means of cement. These brasses are made in various shapes and sizes by tool manufacturers, or the ingenious watchmaker can make them for himself during his leisure hours, Figs. 53 and 54. The watchmaker should have a supply of these brasses, varying in sizes from one inch to the smallest size necessary. Should you have a watch



Fig. 53.

that has a broken cock or foot jewel, and among your supply you are unable to find one that fits both the pivot and the recess in the cock or potence, you will find these brasses very useful. If you find a jewel that fits the pivot nicely, and the brass setting is too large, select a cement brass that is just a trifle smaller than the recess in the potence, cement the jewel to the end of the brass, with the flat side of the jewel to the brass, so that if the brass setting of the jewel is too thick it can be turned to exact thickness of the old setting at the same time that the diameter is turned. Bring to an exact center by the hole in the jewel, by means of a pegwood, and as soon as the cement is hard, turn down with a sharp graver. With a full set of these brasses a watchmaker can utilize odds and ends, without waiting to send for new jewels. The above is only one of many uses to which these brasses may be brought.



Fig. 54.

CENTERS. Pins used in conjunction with a lathe for holding work while revolving. They are usually made of steel. They are of two forms, known as male and female centers.

Female Centers. These very useful adjuncts to a lathe are easily made by any watchmaker. He should have at least six pairs, the largest being one-fourth of an inch in diameter, which will accommodate as large a piece as you will wish to handle on your watch lathe, viz: winding arbors for clocks. These female centers are made from steel tapers, the same as male centers are made, but instead of turning the end to a sharp point they are countersunk, Fig. 55. First place the taper in a chuck and turn off the outside and end true; drill a small hole in the center of the taper, while the lathe is running, and deep enough so the countersink will not reach the bottom of the hole, or one-eighth of an inch deeper than the counter-sink. Harden the end only, and after tempering polish off the bluing. After you have made all the sizes you require, test all of them in your lathe to make sure they did not get out of true in tempering.

These female centers are very useful for holding or suspending any article in the lathe that is too large to be held in the split chucks. Pivots of clocks can be turned and polished very quickly and accurately in these centers.

Almost any kind of large work can be done on a medium sized watch-maker's lathe by fitting a face plate to the lathe, say one and three-fourths inches in diameter, with four slots, and fitted to a chuck with a taper hole to receive both male and female centers.



Fig. 55.

The taper hole being standard, the centers are interchangeable, and with two styles of dogs, almost any kind of large clock work can readily be handled.

These centers prove very useful for many odd jobs. As an example: It is a very common occurrence to hear an American clock beat irregularly, caused by the 'scape being out of round. Select a pair of female centers that will admit the ends of the pivots of the 'scape wheel snugly; place one center in the taper chuck and the other in the tail stock spindle, and suspend the 'scape pinion in these centers; fasten on a dog, run the lathe at a high speed and hold a fine, sharp file so it will touch the teeth of the 'scape wheel slightly, and in a moment the wheel will be perfectly round, after which sharpen up the teeth that are too thick.

Male Centers. Conically pointed pins; the opposite of female centers.

CENTERING ATTACHMENT. The Potter patent self-centering lathe attachment, shown in Fig. 56, will be found useful in rapidly bringing work to an accurate center, when pivoting, staffing, etc.

The attachment, which may be fitted to any make of American lathe, consists primarily of the side bed pieces *R* and *D*, the upright plate *A*, and the reversible anti-friction sliding jaws *ooo*. The upright plate *A* is attached to the slide *D* in such a way that it may be readily raised or lowered or adjusted in any other direction at pleasure; and may be set with either side facing the lathe head. Of the reversible sliding jaws *ooo*, which are made of Phosphor Bronze Anti-Friction Metal, not requiring the use of oil, four sets of three in a set, are furnished with each attachment. These are of different form, as shown at *XVOU*, to adapt them to the various kinds of watch work, and are operated in radial grooves in the upright plate *A*, by means of the rotating lever *L*, which moves the three jaws in and out, to and from the center, or opens and closes them in perfect unison. One set of jaws may be withdrawn and another set substituted therefor in a few moments. With each change of the jaws, however, the plate *A* requires readjustment; but this, too, may be done in a few moments, as follows: Having previously provided yourself with a bit of straight wire or small steel rod, turned to

run perfectly true in your lathe, and having fastened this in the chuck in your lathe, loosen the nuts *C C* so as to give freedom of movement to the plate *A*; then bring the attachment to proper position on the lathe

bed and fasten it there; after which move the sliding jaws inward until they bind lightly on the bit of straight wire held in your chuck, and in this position again tighten the nuts *C C*. Once adjusted to accurate center in this way no further adjustment, whatever the size of work to be operated upon, is required, until another change of jaws.

In use, the end of the work to be operated upon is placed in an accurate split chuck in the lathe and the chuck tightened on it just sufficiently to hold it in place and to rotate it, the other end being supported in the centered bearing formed by the jaws *ooo*. In this position the jaws *ooo*, or

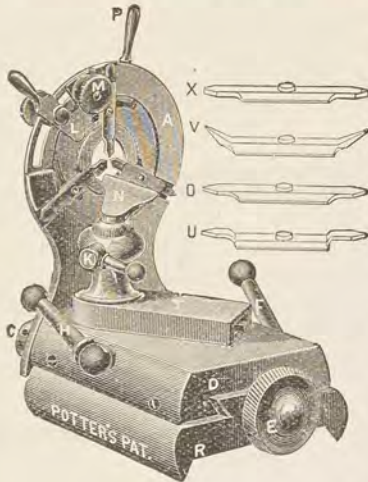

Fig. 56.

such others as for the time may be in use, may be opened and closed as often as desired, and each time will instantly bring the work again to accurate center. See *Rest*.

CENTERING INDICATOR. In centering quickly on the universal head, this tool is indispensable. It will also be found valuable for other work. It is not kept by dealers, and will have to be made by the watch-maker. The body of the indicator is made of sheet brass, and should be about five inches long by two inches in width at the larger end. The shank *C*, is made to fit in rest holder, and is either riveted or soldered to the body; *R* is steel or copper wire sharpened to a fine point, and balances on a pivot at 1; *B* is a clock hand pivoted to the body at 1; 2 and 2 are pivot joints only, and do not go through the body; fig. *C* will perhaps give a better idea of the end *R*. To center with this tool, unscrew your rest and remove it, then place the shaft *C*, fig. 57, in rest holder and adjust it till the needle point *R* touches the top of hole as

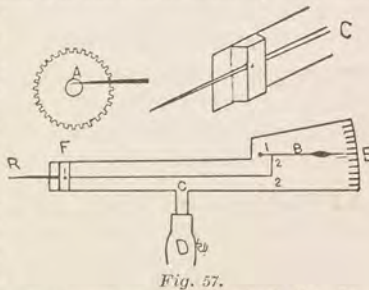

Fig. 57.

shown in Fig. 2. The index hand will then note the variations as the head revolves. If too low, the hand will point above center and if high, vice versa.

CENTERING TOOL. A small, steel point used for accurately locating centers. Fig. 58 illustrates the O. K. centering tool, which is made to fit any tailstock spindle or taper chuck. This tool is inserted in the tailstock spindle and the work to be centered is placed in a



Fig. 58.

chuck or is cemented up on a cement plate. The work is now rotated and the tailstock advanced and the tool will cut an exact center, providing the work in the headstock is central. This tool will be found useful in determining centers when pivoting staffs and in drilling generally.

CENTER PUNCH. A punch having a sharp point, for marking



Fig. 59.

the center of work swung in a lathe, so that it may readily be removed and replaced without the trouble of finding the center each time.

CENTER OF GRAVITY. That point of a body about which all its parts are balanced, or which, being supported, the whole body will remain at rest, though acted upon by gravity. *Webster.*

CENTER OF GYRATION. That point in a body rotating around an axis, at which, if a given force were applied, it would produce the same angular velocity in a given time as it would if the whole mass of the body were collected at that point. *Webster.*

CENTER OF MOTION. That point which remains at rest while all the other parts of a body revolve around it.

CENTER OF OSCILLATION. That point at which, if the whole matter of a suspended body were collected, the time of oscillation would be the same. In a long cone suspended from its apex, the center of oscillation is at four-fifths of its length from the apex, and in a bar suspended from one end is at two-thirds of its length. A pendulum

being irregular in form it is difficult to calculate its center of oscillation, but it always is situated below its center of gravity. The following explanation may aid the student in locating the center of oscillation:

All know that a simple theoretical pendulum is one where the whole weight is centered in one point, suspended from, and oscillating about, a fixed point, or center of suspension. A sphere of platinum, suspended by a fibre of silk, would probably be the nearest approximation to a perfectly simple pendulum. A compound pendulum is one where the weight is not centered in or about one point, but is extended for some distance up and down the rod. Suppose there are fixed upon the fibre, at equal distances, three platinum balls. From the well known fact that a short pendulum vibrates quicker than a long one, the upper or short pendulum will *endeavor* to make its vibrations in the short time due to its length as a pendulum. The middle ball will *endeavor* to make its oscillations in the time its length of support demands, and the lower and longest will attempt the slow and regular vibrations of the long pendulum. Suppose that these three balls, representing three pendulums of three different lengths, be drawn aside from the perpendicular 5° and suddenly released, the consequence will be that the upper one will have made its full excursion by the time the middle one has descended to the perpendicular, and before the lower one has arrived there; the momentum of the three balls bending the fibre of silk into such a curve as will accommodate the *tendencies* of the three balls.

If the silk fibre be replaced by an inflexible rod, and the now rigid compound pendulum be drawn aside as before, the upper ball will *endeavor* to hasten forward the middle one to its own speed, and the middle and upper one will both combine to hasten the lower one. So also, the middle one will retard somewhat the rapidity of the upper one, and the slow-moving lower one will do its best to restrain the haste of both those above it, and the consequence of all these tendencies will be that the lower one will be somewhat accelerated, and the upper one proportionally retarded; the whole assuming a vibration which is the mean (middle ball) of the two extremes, provided the three masses are equal, thus compelling the whole to oscillate as a pendulum whose length is that of the middle ball. But if the lower ball be the largest, its control over those parts above it will be in proportion to its mass and the time of its vibrations will nearly coincide with those made by its center of gravity.

Suppose, again, the largest amount of matter to be in the upper ball. then will its influence be more potent toward forcing the lower and longer pendulums to accommodate their rate to that of the upper one, and their vibrations will be thereby increased to a degree which will approximate the normal vibrations of that short pendulum. Thus you see the difficulty of exactly fixing upon the exact length of any compound pendulum by simple computation. Every particle of matter from the top of the rod to the lower extremity, which differs in its distance from

the point of suspension, has its own time for making an oscillation about that point; and the greater the number of particles that have an equal distance from that point, the greater influence they possess in determining the time of vibration; in this case, as in republics, the mass rules. To obviate these counteracting influences that are constantly at work in the oscillations of the compound pendulum, it becomes necessary to concentrate, as far as possible, all the matter of the pendulum at such a distance from the point of suspension as will produce the number of vibrations desired, and this center of oscillation will always fall in a line produced through the center of gravity and the point of suspension, and will always be below the center of gravity.

The center of oscillation and suspension are convertible points; that is, a pendulum inverted and suspended from the center of oscillation will vibrate in the same time. Huygens, the Dutch scientist, discovered this remarkable fact, and it affords a ready means of determining experimentally the length of a compound pendulum, which may be measured by means of a platinum or lead ball, suspended by a fibre of silk from the same point, and in front of the pendulum to be measured, and of such a length that the vibrations will perfectly coincide in time. The distance from the point of suspension to the center of the ball (which is also the center of oscillation) is nearly the length of that compound pendulum.

It should be remembered that the *center of oscillation* is the point to be affected in all compensations for temperature. The difficulty in producing a perfect compensation pendulum is to harmonize and bring into coincidence the antagonistic tendencies of the center of gravity, center of oscillation and moment of inertia, all of which are properties and peculiarities of compound pendulums, and must be taken into consideration by those who are experimenting upon them with the expectation of producing any arrangement in advance of those in use at present.

CENTER SECONDS. See *Sweep Seconds*.

CENTER WHEEL. The wheel whose staff carries the minute hand.

CENTER STAFF. The arbor, attached to the center wheel, which carries the minute hand.

CENTRIFUGAL FORCE. The tendency that revolving bodies have to fly from the center. It is said that when balances are made too thin in the rim, they alter in diameter from this cause, in the long and short vibrations.

CHAIN HOOK. A small hook which is attached to each end of a fuzee chain, to fasten the chain to the barrel and fuzee.

CHALK. To prepare chalk for use for cleaning gilding, etc., pulverize it thoroughly and then mix it with clean water, in proportion of two pounds to the gallon. Stir well and then let it stand about two minutes. In this time the gritty matter will have settled to the bottom. Slowly pour the water into another vessel, so as not to stir up the sediment. Let stand until entirely settled, and then pour off as before. The settlings will be prepared chalk, ready for use as soon as dried. Spanish whiting, treated in the same way, makes a very good cleaning or polishing powder. Some watchmakers add a little crocus; it gives the powder a nice color at least.

CHAMFER. To groove. To cut a channel in. To cut or grind in a sloping manner anything originally right-angled. To bevel.

CHAMFERING TOOL. A tool for cutting a bevel or chamfer. A tool for cutting a furrow or channel is also known as a chamfering tool.

CHAMOIS. A soft leather used by watchmakers and jewelers, and so called because first prepared from the skin of a species of antelope known as chamois.

Chamois, to Clean. A chamois leather should never be thrown away because it is dirty. It can easily be cleaned and is then better than a new one. Prepare a solution of warm water with a little soda in it. Wet the leather in this and rub it thoroughly with soap and leave it to soak for several hours, after which rub it vigorously until it is quite clean. Prepare a new solution of warm water, a little soda and some soap and rub the skin thoroughly in this to rinse out the dirt. A chamois skin must never be rinsed in water only, or it will come out harsh and dry. The soap in the water leaves the skin soft and pliable. Ivory soap will be found particularly desirable in this respect, as it is rich in fat and has but little rosin and no surplus of lye. After thoroughly rinsing, wrap the skin up in a towel and wring it until dry and then work it thoroughly in the hands until it is dry and pliable and you will have a leather which is superior to a new one.

CHARIOT. A small brass plate, recessed into the under side of the pillar plate of a cylinder watch, and which carries at one end the balance cock, while at the other end the lower balance jewel is mounted. By loosening the screw which holds the plate in place, the depth between the 'scape wheel and cylinder may be altered and still keep the balance upright.

CHIMES. A set of bells musically tuned to one another and sometimes attached to tower clocks, especially in Europe, such clocks being known as quarter clocks, or chiming clocks.

CHIMING BARREL. The cylinder in a chiming clock which raises the hammer in the chiming train, by means of projections upon its surface.

CHOPS. Two metal plates which bind the ends of the pendulum suspension spring.

CHRONOGRAPH. A recording time piece. In modern usage the term is applied to watches having a center seconds hand (driven from the fourth wheel), which generally beats fifths of a second. The hand is started, stopped or caused to fly back by manipulating a push on the side of the case.

CHRONOMETER. A portable time piece of superior construction, with heavy compensation balance, and usually beating half seconds; intended for keeping very accurate time for astronomers, watch-makers, etc. See Fig. 60.

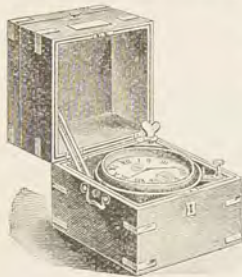
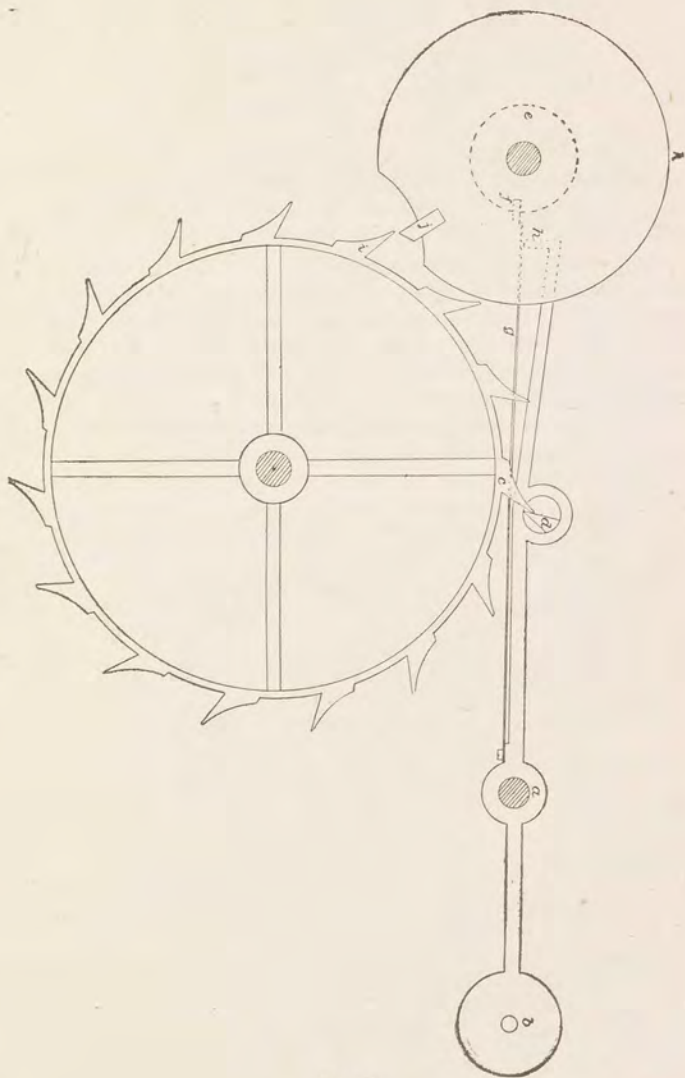

Fig. 60.

Marine Chronometer. A chronometer hung in gimbals, for use at sea in determining longitude.

Pocket Chronometer. A pocket watch with chronometer escapement.

CHRONOMETER ESCAPEMENT. A form of escapement in which the impulse is given direct from the escape wheel to the impulse roller on the balance staff, the locking being accomplished on a separate piece known as the detent, from which it is sometimes called detent escapement. The detent is made of two principal forms which constitute the two varieties of this escapement. The one shown in Fig. 61 is the pivoted detent which is sometimes termed the bascule escapement by foreign makers, while Fig. 62 shows the spring detent. This escapement appears to have been invented by Pierre LeRoy, in the year 1766. In the earliest forms the unlocking, or as it is sometimes called, the gold spring, was mounted upon the balance staff, but was subsequently transferred to the detent, similar to the present form, also the escape wheel was sometimes made with two sets of teeth similar to the one used in the duplex. From its first

*Fig. 61.*

inception up to the present time it has passed through many forms and modifications, until it has finally arrived at a stage where it approaches perfection very closely when made by the best makers.

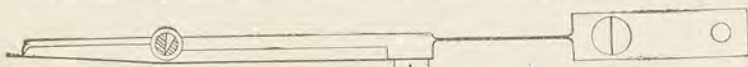

Fig. 62.

When well made this form of escapement leaves but little to be desired for timekeeping; but while its action is simple, the application of the principles underlying its construction must be correctly applied, as well as that the workmanship be of the highest quality.

Action of the Escapement. In Fig. 61 the tooth *c* is at rest upon the locking stone *d*. The dotted circle *e* represents the unlocking roller which is mounted upon the balance staff beneath the impulse roller *k*. The unlocking spring *g* is rigidly held at the back end by a screw, while the end next to the balance is free to move towards the escape wheel, but when pressed in the opposite direction it will carry the detent with it by striking against the horn of the detent *h*, thus accomplishing the unlocking of the escape wheel for the succeeding impulse. Upon the detent arbor there is mounted a small spiral spring, not shown, of the same form as the balance spring only very much smaller and having four or five coils for the purpose of returning the detent to the locking position. This spring is mounted by means of a collet and is held by a stud similar to the balance spring. As shown the unlocking pallet is in position ready to unlock the escape wheel, thus allowing the tooth *i* to fall upon the impulse pallet *j*, which imparts the impulse to the balance through the impulse roller *k*, which is mounted upon the balance staff in a similar manner to that of the roller in a lever escapement. Having received an impulse the balance continues its excursion around to the left, until the momentum of the balance has been absorbed by the balance spring. The balance is immediately started upon its return vibration by the tension of the balance spring produced by the impulse and the momentum of the balance. The unlocking pallet in returning strikes upon the back of the unlocking spring, but as it is free to bend in this direction no other action takes place.

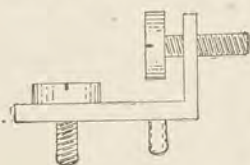

Fig. 63.

When the balance returns again the unlocking pallet strikes against the unlocking spring, which is resting against the horn of the detent, thus unlocking the escape wheel, ready to deliver another impulse. There is a banking screw in the marine chronometer, shown in Fig. 63, against which the detent strikes and the amount of lock is adjusted. This screw is usually located about the center of the locking stone,

but in all cases it should be located at the point where the detent will come to rest with the least jar or trembling, which would be very detrimental to accurate timing. The escape wheel makes a revolution in the same time as that of the lever escapement, because each tooth delivers but one impulse, and the entire space between two teeth passes every time the detent is unlocked, while in the lever each tooth gives two impulses. While the balance in this escapement is more nearly free from errors of the train which makes it so accurate as a timepiece, it is nevertheless at the same time very sensitive to external shocks, and for this reason is not suitable for carrying in the pocket except in rare cases when carried by a careful person. Another reason why it is not suitable for ordinary wear is its liability to set, that is the motion of the balance is counteracted to a greater or less extent, which may be sufficient to entirely stop the watch, and as this escapement has no power to start itself, even in the highest grades, the watch would stand still until again started. The escapement shown in Fig. 61 is taken from one of Jules Jurgensen's pocket chronometers, and in the drawing is shown enlarged ten times. These measurements were very carefully taken and transferred to the drawing, so that it may act as a reliable guide to those who may wish to construct one.

The Escape Wheel. The wheel is made of brass or gold, which should be well hammered to harden it and give it rigidity, which is very essential, as it must be left as light as possible. The teeth are cut by a cutter whose cutting edge conforms to the circle of the wheel and the back of the teeth are cut by a cutter of suitable form. After the teeth are cut a hole is bored through a plate, which may be of steel and then hardened, which corresponds to the inner circle of the rim of the wheel and concentric with this a recess is turned out into which the escape wheel will just enter freely.

The arms of the wheel are to be carefully worked out by hand, using small files and working carefully so as not to distort the metal. The greater part of the metal between the arms may be removed by drilling several holes which will expedite the work somewhat. For finishing up the arms a guide can be made by turning a disc of steel whose outside diameter corresponds to that of the escape wheel, so that it may enter the same recess, and then cutting almost half of it away, or half the width the arm is to be over half the diameter, also leaving a portion remaining, which will correspond to the hub of the wheel. If the piece before mentioned was made of steel and hardened it will act as a guide for forming the inner circle of the rim. After the arms are cut out and nicely smoothed the wheel may be cemented into an accurately fitted recess turned into a cement brass and the arms thinned down to about half the thickness the rest

of the wheel is by turning out with the slide rest or other suitable attachment, using a very keen tool which will leave a smooth and polished cut. The points of the teeth should not be left sharp, but should be imperceptibly rounded. Sometimes the recessing is carried out as far as the base of the teeth, leaving a sharp angle, and in others it is carried to the points of the teeth in a gentle curve, beginning at their base. This latter form makes the lightest wheel, but is somewhat more difficult to make and does not look quite so nice as the first form, as the flat top of the rim and teeth may be highly polished upon an agate polishing stone, such as is used to polish jewel settings, etc. The cutters used for cutting the teeth should leave a smooth, polished cut, as the teeth should not be changed from what the cutter left them.

The Detent. The counterpoise of the pivoted detent affords a ready means of poising it, so that the question of a long or short detent has not the same importance as it has in the spring detent. In the spring detent the spring must sustain all the weight of the outer end so that it is advisable with this form to make it as short as may be safely done. With a long spring detent, of course, there will be more metal to be sustained by the spring, so that it must be left thicker, and this will make the work performed by the balance so much the greater, which is a detriment when held in such a position that the weight of the detent acts to increase or decrease the unlocking resistance.

Saunier in his *Modern Horology*, article 850 says: "In the case of the marine chronometer as now made, it has been experimentally ascertained that the acting length of the spring detent should not be less than the diameter of the escape wheel, nor more than the radius of the balance. A pivoted detent, measured from the center of motion to the extremity of the auxiliary spring, should be much shorter (by rather more than one-third this amount): for otherwise its weight, being increased by that of the counterpoise, would render the action of the escapement uncertain, especially in pocket chronometers beating 18,000 or 21,600 vibrations per hour." It is difficult to see the logic of his reasoning regarding the pivoted detent. The only hypothesis on which his reasoning would seem to apply would be where the counterpoise was added merely as an ornament, without due regard to the poising of the detent, a thing which is very necessary, in this respect having an advantage over the spring detent. Making a new or replacing a broken detent is about one of the most difficult jobs the watchmaker has to undertake, especially in the latter case, when its location and proportions are already determined. In making a detent it will result beneficially if the measurements are made directly onto a steel plate sufficiently large that all the various

proportions may be made directly upon it rather than making them on a separate plate and then transferring them to the piece of steel from which the detent is to be made. The selection of the steel from which the detent is to be made is very important, as it must be made as light as possible and yet sufficiently rigid to withstand the impact of the locking. The conditions above enumerated can only be satisfied by using steel of a very superior quality, and in this respect almost any steel may be improved by carefully hammering it, which will make it more dense. Another reason for using a plate from which to make the detent is that the holes may be drilled more accurately at right angles to the plane of the detent. When all the points of the detent are located, drill all the holes and rough it approximately and harden, drawing it to a spring temper of dark blue. If a lead or cyanide bath be at hand for heating, only ordinary care will be required in hardening, but if a blow pipe is used great care will be necessary to avoid overheating, which would ruin it. When replacing a broken detent the centers of the different parts should be marked upon the plate, which has been carefully smoothed, and by mounting the impulse pallet upon a well made arbor a hole is to be drilled into which this arbor will accurately fit, the same being done with the escape pinion. By this method the face of the locking stone may be accurately located. In the spring detent the corners where the spring joins the body of the detent to the foot, should be left slightly rounded, not taking special care to have them extremely sharp, which would make them liable to be broken. The amount of this rounding should be slight, almost an imperceptible amount being quite sufficient. After the hardening process the forming may be proceeded with by using a fine file, which should be new and sharp, that the metal may not be in any way strained or injured, finishing off with carborundum powder, and a tin slip if to be left unpolished, or if to be polished, using a zinc slip and diamantine. Mr. Britten says "The locking pallet should not be perfectly upright. It should lean a little from the center of the wheel, and a little towards the foot of the detent, so that the locking takes place at the root of the stone, and then the action of locking and unlocking does not tend so much to buckle the detent. The face of the impulse pallet, too, should be slightly inclined so that it bears on the upper part of the wheel teeth. By this means the impulse pallet will not mark the wheel in the same spot as the locking pallet."

If the above theory be true why is it necessary to go to such expense and care that each part be accurately made, but that the above reasoning is incorrect we cite a few facts below and endeavor to show why the locking and impulse pallets should be set perfectly upright, taking extraordinary care that they be so set. By setting the locking stone upright there can be no tendency to buckle the

detent, for the pressure will come equally upon the top and bottom of the locking pallet, and the wear being distributed equally upon the surfaces, the wear will not be so great. With the pivoted detent the locking pallet may be set very near on a radial line so that it will have just a small amount of draw, as, if the detent be accurately poised, the force of the locking spring will be sufficient to prevent the escape wheel becoming unlocked at the wrong time, but with the spring detent a perceptible draw is necessary, ten degrees being sufficient when well constructed.

The Unlocking Spring. The unlocking spring is made of gold, hammer hardened, and made as light as possible, from one and one-half to two-thousandths of an inch in thickness. It should be made longer than necessary, then cut off so that it will only carry the detent out sufficient to well clear the teeth of the escape wheel and should point directly towards the center of the balance.

The Rollers. The unlocking and impulse rollers are made of tempered steel, the slots for the pallets being cut so that their front faces are on a radial line to their center. The outer end of the impulse pallet should be just equal to the roller, while in the unlocking roller the pallet extends beyond the edge of the roller so as to strike the unlocking spring.

The Pallets. Ruby or sapphire are the only stones sufficiently hard from which the pallets should be made. The impulse and unlocking stones should be sloped off at the back, while the locking one is brought to an edge as indicated at *d*, Fig. 61, so that it may not strike the back of the tooth when returning to the locking position. The half of the locking pallet which is cut away is filled in by a half round brass plug cut off flush with the detent face. The unlocking and impulse pallets are carefully fitted to the slots and held in place by shellac. The edges of all the pallets should be slightly rounded and carefully polished.

Examining the Escapement. Before taking the watch apart, the several actions should be examined and any fault noted. See that the balance is true, both in the round and flat; also notice the action of the balance spring and that it develops uniformly. Try the various endshakes, which should be only the amount necessary for freedom. If the sideshake at the pivots is more than what is necessary for freedom, a new jewel should be fitted or a new part made, depending upon which is at fault. Stop the balance and notice the location of the impulse and unlocking pallets. When at rest the unlocking pallet should stand near the unlocking spring with the impulse pallet near the tooth of the escape wheel, which will deliver

the next succeeding impulse, but the position of none of them should be changed until the watch has been tested for isochronism and in the various positions, since they may have been thus placed to complete some of the adjustments. Notice the amount the unlocking pallet carries the detent beyond what is necessary to unlock the tooth and at the same time see that the incoming tooth strikes safely upon the impulse pallet; also the distance the pallet is forward of the tooth at the time the tooth falls upon the pallet. The extent of the drop should not exceed five degrees, and may sometimes be slightly less. The distance between the edge of the impulse roller and the two escape teeth immediately adjoining it, that is, the tooth which has just given the impulse and the one which will immediately follow it, should be just sufficient to leave the parts free and should be equally divided on each tooth. If the lights, as they are called, are not equal, it shows that the position of the locking stone is not correct and which way it should be moved to correct the fault. Excessive side-shake at the pivots, especially at the balance, might cause the inequality above referred to when held in certain positions. The escape wheel must be true in the flat, noticing that none of the teeth are faulty. The heights of the rollers should be so as to engage the escape teeth and the unlocking spring.

The amount of lock of the tooth upon the locking pallet should be as small as possible, leaving a sufficient margin for safety. No workman who is not thoroughly acquainted with this escapement should attempt to repair it, for, since none except a first-rate workman could expect to make one which would give satisfactory results, so, none but a workman of equal skill can expect to repair it without leaving it in an imperfect condition.

Munger's Improved Chronometer Escapement. In this escapement, which is illustrated in Fig. 64, the detent and staff are in one piece, with a notch in the head to hold the locking jewel. The detent arm has a hole through it to receive the detent staff, fitting friction tight, so that the detent and arm can be set at the proper angle to each other, and then the staff driven down to the shoulder. These should not fit so tightly that they cannot be separated without danger of breaking, but so firmly as not to be moved out of proper position to each other by use or handling, etc. Figure 64 shows the escapement and impulse pallet of the usual construction. The diameter of the pallet should not be less than six-tenths (.6) the diameter of the escapement, or larger than two-thirds the size of the wheel. *A a* shows the line of centers of the escape wheel and balance; *b b* the circle of

depthing of the escapement and detent from the balance holes; *cc* extends from the intersection of the periphery of the wheel with the line *aa*, and the point of the third tooth of the wheel across the circle *bb*. At the intersection of the lines *bb* and *cc* is the point of location of the detent pivots (a slight variation from this point is not important). The discharge, or unlocking pallet, shown by the dotted lines, is a light bar or arm with a notch at one end to hold its jewel, and is the same length or diameter as the impulse pallet (or nearly so). In planting the escapement, first mount the wheel on its pinion and top it just enough to have it round. Then use a temporary brass or steel disc, the size required for the impulse

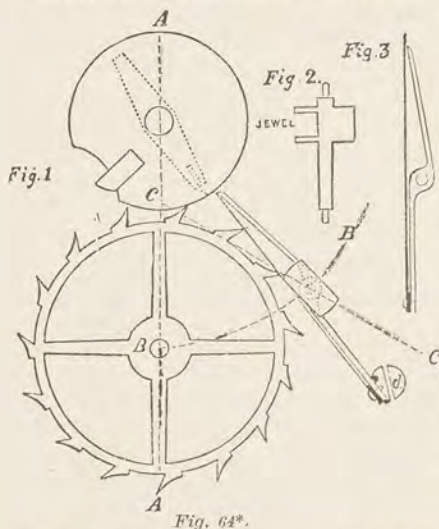

pallet, place it on the balance staff, and adjust the depth of it and the wheel in the depth tool, and mark the circle *bb*. Locate the escape wheel and detent pivots the distance apart indicated by the drawing, and pivot them in, as also the balance, in their proper positions. In the brass disc cut a notch large enough to allow the escape-wheel tooth to pass through as in escaping. As the detent jewel is too long to allow of the proper locking of the wheel, let a tooth of the wheel rest on the locking

face of the detent (the notch in the disc allows this), and the distance of the entrance tooth from the disc readily shows about how much of the detent jewel has to be ground off before beginning to polish its locking face. Two or three trials will bring it so near that the final polishing will make the locking correct. All this really takes but a few minutes to do.

To obtain the adjustment of the detent use a special tool. The spindle is hollow, and the front end reamed out to take in a small brass taper

*Fig. 1 represents a plan, or face view, of the escapement, showing the method of locating the relative positions of the balance, escape wheel and detent pivots.

Fig. 2 is an elevation of the detent, detached from the detent arm

Fig. 3 is a plan view of the detent arm and gold spring attached to it. *D*, eccentric banking screw to adjust the position of the detent arm and depth of locking the escape wheel. The distance of the detent pivot from the escape wheel can be determined and laid out with sufficient accuracy as one-fifth to one-fourth of the distance shown in the drawing.

that also fits a chuck in your lathe-spindle; this small taper is drilled out, with as large a hole as convenient, from the back end to within about one-eighth of an inch of the front. It is then put in the lathe-spindle and the front end turned small enough to be out of the way of the lap, and carefully centered and drilled through into the large hole, and broached out just enough to hold the detent staff firmly by friction, while grinding and polishing the locking surface; and it is readily removed from the taper to try the detent for the correct locking.

In making this adjustment, the arbor carrying the polishing lap should be held firmly, (by means of a loose button on the front end of the spindle) against the adjusting screw *r*, and this screw turned a little at a time, as the length of the detent jewel is shortened, so that the locking face will be a true circle from the pivots; for if the locking corner is much rounded off, or beveled, the pressure of the wheel against it would push the detent out, and cause it to trip or unlock at the wrong time. If the circle is true from the pivots, no amount of pressure of the wheel against the detent can push it out or release it.

With the size of discharge pallet used, the unlocking action can begin, if desired, from $\frac{1}{4}$ to $\frac{1}{3}$ of the whole motion of the detent arm before the line of centers, and is adjusted by the eccentric banking screw *d*. The relative position or angle of the detent to the arm is then so adjusted as to give the right amount of locking to the escape wheel, (which can be very shallow). The gold spring is then shortened, so that it will be released from the discharge pallet when the escape wheel tooth and impulse jewel are about on the line of centers; if the gold spring is too short, the detent will return too soon, so that the inside face of the locking jewel will strike the point of the tooth of the escape wheel, and the wheel drag along the face of the jewel until the detent arm rests against the banking screw *d*. This must be avoided.

The discharge pallet, of course, must be set so as to unlock at the right position of the impulse pallet, but less drop is required in this escapement than in the usual construction.

The spiral return spring on the detent staff, under the arm, should have tension enough to return the detent to its banking, when it is moved a trifle, with all the pressure on it from the train that the main-spring can give. Use five or six coils for the return spring, and put on the spring so that it opens when the detent is moved to unlock, as this gives a trifle quicker action to start the detent on its return. The detent, all complete, is so very light that there is no recoil as it strikes the banking, and no jarring or outside motion will cause it to trip, as all others are liable to do.

The extreme lightness of the detent with its locking so near the pivot, lessens the friction so greatly that the discharge pallet can be of the same diameter as the impulse pallet, and thus greatly lessen the angle or extent of motion required to start it going; and it also admits of very

shallow locking, without the least danger of tripping, and requires much less strength of mainspring than any other detached escapement.

CHRONOSCOPE. A clock or watch in which the time is indicated by the presentation of numbers through holes in the dial.

CHUCK. A mechanical contrivance for holding work in a lathe. True chucks are the most important adjuncts to a watchmaker's bench. A good lathe and untrue chucks will result in inferior work, while a cheap lathe with true chucks will permit of some good results. Chucks hold the work truest that come the nearest fitting the hole in them. Trying to hold work too large or too small, will soon get them out of true, and often make the workman dissatisfied with his chucks, his work, himself and his lathe. Wax is the only sure thing for fine staff and pivot work, *although there are many substitutes that do very well, and with the aid of them a good workman can turn out a very fine job.

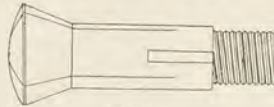

Fig. 65.

With a good lathe, true chucks and sizes to suit, and a reasonable amount of practice, first class work can be done with split chucks. One chuck or tool of any kind seldom does all kinds of work and does it well.

Fig. 65 is a good example of the modern split wire chuck, such as is furnished to go with all American made lathes.

The table of American wire chucks on page 79 will prove useful to those persons who contemplate purchasing chucks for lathes of foreign manufacture.

Adjustable Chuck. The Hopkins patent adjustable chuck, shown in Fig. 66, is designed to grip and hold firmly and accurately any size of work from the smallest staff to the largest pinion, watch wheels of all sizes, mainspring barrels and other large work, and can be adjusted to any make of lathe by simply placing it friction tight, on a plug chuck fitted properly to the lathe. In using this chuck for staffs, pinions, wire, etc., fasten a V piece 7, of proper size, in the hole in attachment 6, taking care that both the V and the seat in which it rests are free from chips, dirt, etc. Then lay your work in the V and fasten it there by means of the sliding jaw above it. This done, place the attachment on the face of the chuck body, with the disc slipped under the heads of the two spring bolts, and then spin the work to center, same as when using wax. After centering thus, fasten the disc to place by tightening the nuts on the back ends of the spring bolts.

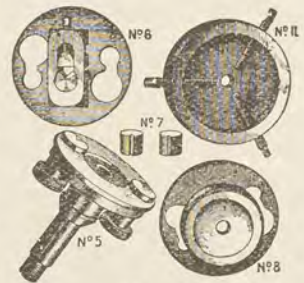

Fig. 66.

DIMENSIONS OF AMERICAN CHUCKS.

NAME OF CHUCK.	DIAMETER OF BODY IN INCHES.	DIAMETER OF BODY IN MM.	LENGTH OF CHUCK IN INCHES.	ANGLE OF SHOULDER.	PITCH OF THREAD.	LARGEST HOLE CLEAR THROUGH IN MM.	SIZE OF LARGEST HOLE IN MM.
Moseley, No. 1.....	.240	-----	1.28	25°	Eng. 48	38	47
Moseley, 1 x 2.....	.3135	-----	1.34	20°	Eng. 40	50	65
Moseley, No. 2.....	.3135	-----	1.58	20° Con.	Eng. 40	50	65
Moseley, No. 3.....	.400	-----	1.82	20° Con.	Eng. 36	65	75
Whitcomb, No. 1.....	.197	5	1 $\frac{1}{8}$	20°	Eng. 50	30	35
Whitcomb, No. 1 $\frac{1}{2}$256	6 $\frac{1}{2}$	1 $\frac{1}{8}$	20°	Eng. 40	40	50
Whitcomb, No. 2 or W. W.....	.315	8	1 $\frac{3}{8}$	20°	Eng. 40	50	60
Hopkins, No. 1.....	.2285	-----	1 $\frac{1}{8}$	25°	Eng. 48	28	42
Hopkins, No. 3.....	.2635	-----	1 $\frac{1}{8}$	25°	Eng. 40	37	50
Hopkins, 3 x 4.....	.3255	-----	1 $\frac{3}{8}$	25°	Eng. 40	52	66
Kearney & Swartchild.....	.300	-----	1 $\frac{1}{8}$	25°	Eng. 44	48	57
Elgin or Triumph.....	.275	-----	1 $\frac{1}{8}$	25°	Eng. 50	45	52
Rivett.....	.300	-----	1 $\frac{3}{8}$	20°	Eng. 40	47	57
Geneva.....	.1965	6	1 $\frac{3}{8}$	20°	Met. 14	34	45
Stark, No. 1.....	.1875 or $\frac{3}{16}$	-----	-----	-----	Eng. 48	23	30
Stark, No. 2.....	.2205	-----	-----	-----	Eng. 48	28	42
Stark, No. 3.....	.245	-----	-----	-----	Eng. 48	28	45
Stark, E.....	.300	-----	1 $\frac{3}{8}$	20°	Eng. 40	50	57

For holding work by the web of the wheel, place the wheel under the screw cap on the face attachment 8 and screw the cap down firmly on it, with the staff or pinion projecting outward through the center hole. This done proceed the same as when using No. 6.

For mainspring barrels and like work, use attachment 11, and place a bit of broken mainspring between the work and the ends of the three binding screws, and tighten the screws down on that instead of directly on the work.

Arbor Chuck. A screw chuck on the end of which is a threaded

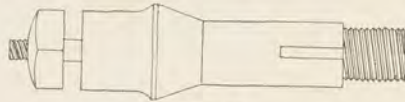

Fig. 67.

arbor for the reception of saws, laps, etc., which are clamped in position firmly by means of a nut or thumb screw as shown in Fig. 66.

Bezel Chuck. The Snyder patent Bezel Chuck, shown in Fig. 68, was originally intended for holding bezels only, but it is now made so that it will hold watch plates, coins, etc., and is adjustable to any size. It can be fitted to any lathe and requires but very little practice to use it, as it is extremely simple and any one who uses a lathe can make or repair bezels in a workmanlike manner. It holds the work as in a vise,



Fig. 68.

and no amount of turning or jarring will loosen the jaws, while it may be opened and closed instantly by simply turning the milled nut behind the face plate, thus enabling the operator to turn and fit a bezel perfectly, by trying on the case as many times as necessary. It holds the bezel by either groove, so that the recess may be turned out when too shallow or too small for the glass, or the bezel may be inverted and turned away when it rests too hard on the dial. It will be found especially useful in turning out the inevitable lump of solder from the recess in the bezel, after soldering and in fitting to case, as the process of soldering generally makes the bezel shorter; and consequently it will not fit on the case. It also renders the operation of polishing bezels after soldering, but a few minutes' work. In turning out the recess for glass in bezels, especially heavy nickel bezels, it will prove a friend indeed, when for instance, you look through your stock of flat glasses and find none to fit, but have one that is just too large. All watchmakers know that if the groove in the bezel is imperfect it is apt to break the glass. The chuck is also useful as a barrel closer, holding work while engraving, and many other uses that will present themselves to the watch or case repairer.

Cement Chuck. The Spickerman patent cement chuck, shown in Fig. 69, is a very handy device, as it holds and centers accurately any wheel in a watch while drilling, polishing or fitting new staffs or pinions,

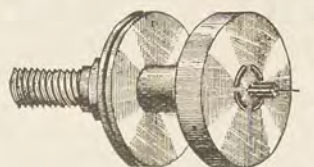

Fig. 69.

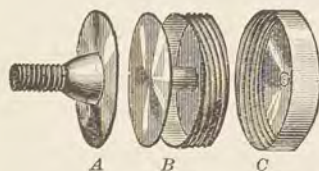

Fig. 70.

and all danger of injuring wheels is obviated. It fits all kinds of American or Swiss lathes. The holder shown in Fig. 70 at *a*, is turned down to nearly the size of the screw for the lathe and the screw cut so the holder will set as close as possible to the lathe. The face of the holder is then turned perfectly true. Put wheel to be centered in cap *c*, as near to center as convenient and screw on *b*. Then place cement face of chuck *b* against face of holder *a* on the lathe and with a lamp, warm the cement between the surfaces, holding the chuck

with a stick against the pivot of wheel in the cap, and it will move to an exact center as soon as warmed sufficiently. New cement should be added occasionally between the surfaces, as it hardens and burns away and does not center as well as when new. Fig. 69 shows chuck with wheel inside ready for drilling. See also *Cement Brasses*.

Chuck Stepping Device. In this device, shown in Fig. 71, *A* rests in chuck slightly less than diameter of work. *B* tightens in rear end of draw-in-spindle. Turning *c* regulates depth of step.

By the use of this tool any wire chuck will accurately serve as a step chuck. It is a device of great service to the watchmaker when used and understood. It enables him to make a step in any wire chuck of any depth he may wish, and will push out the work if desired. It is very useful many times for a stop for marking or cutting off when you want a number of pieces of the same length or kind. Many object to the stepped chuck for general use, objections which this device obviates.

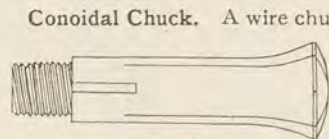

Fig. 72.

Conoidal Chuck. A wire chuck which has a conoidal shape in lieu of the shoulder usually left^a on wire chucks for the bend in the lathe head. Fig. 72 illustrates the usual form of conoidal chucks.

Crown Chuck. A chuck for holding watch crowns while undergoing repairs of various kinds. Figure 73 illustrates the Dale chuck, which is



Fig. 71.

made on the lines of the ordinary split wire chuck, a large recess being turned in the end for the reception of the crown. The draw-in of the chuck holds the crown firmly in place. Fig. 74 illustrates the Johanson chuck, which is intended to hold all sizes of



Fig. 73.

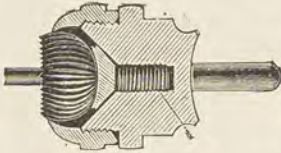

Fig. 74.

crowns, from the smallest to the largest. The figure clearly shows the adjustment of parts. This chuck is manufactured in two styles, one like Fig. 74, which is ready to insert into a number 40 wire chuck of an American lathe, while the other style is mounted on a regular chuck and is always ready to insert into the lathe head, the same as an ordinary split chuck.

Dead Center Chuck. By the use of this chuck, shown in Fig. 75, the work can be run on dead centers as well as by the bow or verge lathe, and the motion will be continuous.

Drill Chuck. A small chuck



Fig. 76.



Fig. 75.

for holding drills, made to fit in tail-stock spindles or taper chucks. Fig. 76 illustrates the Gem Pivot Drill Chuck.

Jeweling Chuck. The Hutchinson Jeweling Chuck, which is shown in Fig. 77, is intended as a substitute for wax, when manipulating jewels. The cut represents a full size chuck, which is made similar to the ordinary split chuck, but has an adjustable center which can be moved backward or forward by means of the screw in the rear, and is used to support the jewel while in place in the chuck. They are made in three sizes. Another form of jeweling chuck is shown in Fig. 78, and is known as the Deuss Chuck. It is a self-centering chuck which will hold all sizes of jewels and fits the wheel or step chucks of all American lathes.

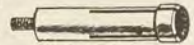

Fig. 77.

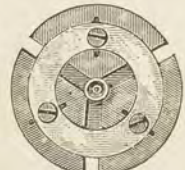

Fig. 78.

Pivoting Chuck. The Gem patent pivoting chuck, shown in Figs. 79 and 80, is intended as a substitute for wax for pivoting and like work.

By the means of the ball *b*, placed between the two sliding sockets *c c*, with the several other parts as represented in Fig. 79, a combination of sliding and ball and socket movements in connection with a spring pump center, is obtained. A set of ten or more, supplementary chucks *g*, with different sizes of center holes, and attachment *n*, for all sizes of wheels, are furnished with each chuck. The supplementary chuck *g*, in the form

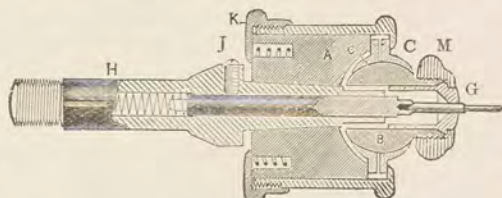

Fig. 79.

of a small split chuck, is made to fit into a hole with taper mouth in the center of the ball *b*, and is drawn into place and the work fastened firmly in it by means of the binding nut *m*, which screws on to a projection extending outward from front side of the ball.

To use this chuck proceed as follows: Remove the nut *m*, and give freedom to the working parts by loosening the large back nut *k*. Then to bring the hole through the ball *b*, into line, spin the ball to center, first at the base of the projecting screw and then at the mouth of the hole through it, and in this position again fasten the parts, by tightening the nut *k*. Then give freedom to the pump center by slightly loosening the set screw *j*. When doing this, hold your finger against the front of the chuck, to prevent the center rod from shooting out of its place when

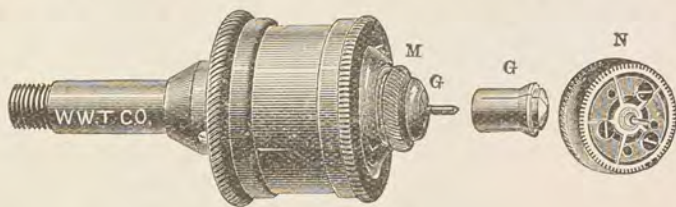

Fig. 80.

freed. Then having placed a supplementary chuck *g*, of proper size, in its place in the chuck, and your work in it, with its back end resting properly in the countersink in the end of the pump center, fasten it there by screwing the cap *m* down snugly over it, using a small lever pin when necessary for this purpose, but not with undue force. Then again loosen the nut *k* and spin the work to center at its outer end; and then tighten both the nut *k* and set screw *j*. In tightening the set screw *j*, make sure it is so tightened as to prevent the pump center from slipping from place

when working. If from tightening the screw *j*, it is found that the work has been thrown in any degree away from true center, loosen the nut *k*, leaving the pump center fast, and again spin to center, and fasten as before. All of which after a little practice may be done, and the work be brought to absolute truth in a few moments.

In using attachment *n* for wheels, the nut *m* and chuck *g* are removed, and *n* substituted therefor; the work being held on the face of the attachment by flat headed screws that grip the arms of the wheel. For cylinder escape wheels a special attachment *n* is furnished. The best thing to use when spinning work to enter in the chuck, is a bit of peg wood of wedge shape at one end. The countersinks in the ends of the pump center should in all cases be carefully tested, and if need be trued up in the lathe in which the chuck is to be used. In doing this, use a good, fine-pointed sharp graver, and make sure the countersink is perfectly true. The same rules in regard to truth in the countersink, and having the work rest properly in it, are to be observed in using this chuck as when using wax.

Screw Chuck. A solid chuck having a threaded hole in the end for the reception of cement brasses, laps, etc., as shown in Fig. 81.

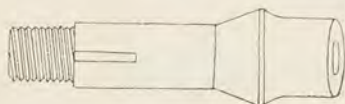

Fig. 81.

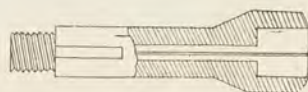

Fig. 82.

Shoulder Chuck. A chuck having a large opening in the end with square shoulders for the work to rest upon as shown in Fig. 82.

Step or Wheel Chucks. These chucks are usually made in sets of five, each chuck having nine steps, giving forty-five different sizes. These chucks are very useful in holding main spring barrels, to fit in the

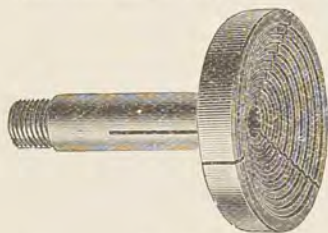

Fig. 83.

cap of the barrel, should it become out of true. They are also valuable in truing up barrels of English lever watches, that are damaged owing to the breakage of a main spring. They are also very useful in holding almost any wheel in a watch, but particularly convenient in fitting a center wheel to a pinion, or in making sure that the hole in the wheel is in the center.

These chucks are made by the various lathe manufacturers and are all similar to Fig. 83, and will hold wheels from .5 to 2.26.

Taper Chuck. A solid chuck having a large opening for the reception of tapers, centers, laps, etc., as shown in Fig. 84.

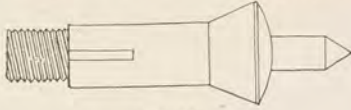

Fig. 84.

CHUCK BOX. A circular box with lid, for holding chucks. They are usually made of cherry or mahogany. By keeping your chucks in a

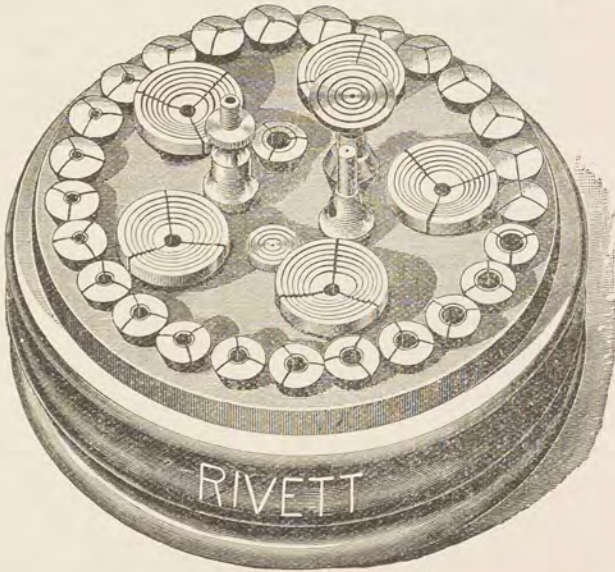

Fig. 85.

box similar to that shown in Fig. 85, you can find a chuck of the desired size in a moment and the chucks are less liable to be damaged than when kept in a drawer with miscellaneous tools.

CIRCULAR ERROR. In a pendulum clock the difference of time caused by the pendulum following a circular instead of a cycloidal path.

CLAMPS. Movable pieces of brass, lead, leather or cork attached to the jaws of a vise while holding objects that would be injured by the vise jaws.

CLEANSING, PICKLING AND POLISHING.

To Clean Pendulums. Brass pendulum bobs are often found with black stains upon them that prove very obstinate to remove. Heat the bob moderately, touch the stains with a brush dipped in nitric acid, rub with a linen rag and again heat moderately.

To Clean Silver. Articles of silver, either solid or plated, are quickly and easily cleaned by dipping in a moderate concentrated solution of potassium cyanide and then thoroughly rinsing in water. Jewelers will find it very convenient to have three stone jars, with tight fitting covers, to exclude all dirt. Label the jars "Cyanide," "1st Water" and "Second Water." In these, large pieces of silverware can be cleaned with ease by dipping into the cyanide, then into jar number one and then jar number two. Dry with a soft linen rag and the articles will be found free from all stains.

To Clean Nickel. The nickel plates of watches are sometimes found to have rust stains upon them. These can be removed by rubbing the spot with grease, allowing them to stand for a few days, and rubbing thoroughly with a cloth moistened with ammonia. In obstinate cases, repeat the operation or touch the stains with dilute hydrochloric acid and rub thoroughly. Rinse in clean water and polish. A mixture of fifty parts of rectified alcohol and one part of sulphuric acid is also valuable for cleaning nickel plates. Immerse for ten or fifteen seconds, no longer, rinse in alcohol, and dry in sawdust.

To Clean Brass. To clean old brass, especially small figures, paper knives, etc., immerse them in a mixture of one part of nitric acid and half part of sulphuric acid. Allow them to remain a short time, rinse thoroughly in cold water, dry in sawdust and polish with Vienna lime, when they will appear like new.

Pickling of Metals. Metals are pickled for the purpose of removing the oxide and producing a lustrous surface. An excellent pickle for brass consists of ten parts of water and one of sulphuric acid. Dip into this pickle, wash, dry, and immediately dip into a second pickle consisting of two parts of nitric acid and one of sulphuric acid and rinse thoroughly. This dissolves the zinc from the brass, and gives the metal a brilliant surface. All pickling operations with either hot or cold pickle should be carried on in the open air or in the draft of a well drawing chimney, as the vapors arising from the acids are very injurious. In order to retain the luster, a good transparent varnish should be applied.

Pickle for German Silver. To twelve parts of water add one part of nitric acid; immerse the article in this, quickly remove, and place in a mixture of equal parts of sulphuric and nitric acid, rinse thoroughly in water and dry in sawdust. In all cases of pickling it is essential that all traces of acid be removed by frequent washings in clean water.

Pickle for Gold Alloys. Gold alloys, especially those containing copper, assume an unsightly dark brown exterior, owing to the copper oxide generated by the repeated glow heating necessary during work. In order to remove this the object must be pickled, and either highly diluted sulphuric or nitric acid is used for the purpose, according to the color the article is designed to have.

If working with an alloy consisting only of gold and copper, either sulphuric or nitric acid may be used indifferently, since gold is not attacked by either of these acids, while copper oxide is easily decomposed thereby, and after having been pickled, the article will assume the color of pure gold, because its surface is covered with a layer of the pure metal.

If the alloy is composed of pure gold and silver however, only nitric acid can be employed, and the article is left immersed in it only for a short time; this acid dissolves a very small portion of the silver, and the article also assumes the color of pure gold.

When working with an alloy which, besides the gold, contains both copper and silver, the process of pickling may be varied in accordance with the color desired to be given to the article. If the pickling is performed in sulphuric acid, the copper alone is dissolved, the article assuming a color corresponding to a gold-silver alloy, which now constitutes the surface of the article.

If nitric acid is used it will dissolve the silver as well as the copper and in this case a pure gold color is produced.

Pickling is done by first feebly glow heating the article and cooling it; this operation is for the purpose of destroying any fat from the hands or other contamination adhering to the article. If it was soldered with some easily-flowing solder, this glow-heating must be omitted, but it may be cleansed from impurities by immersing it at first into very strong caustic lye, and rinsing it with water; it is then laid into the acid.

The acids are employed in a dilute state, taking forty parts water to one part concentrated sulphuric or nitric acid. If more articles than one, they had best be laid beside each other in a porcelain or stoneware dish, the diluted acid is poured over them, and some article is lifted out from time to time to watch the course of proceedings, whether it has assumed a yellow color.

When to satisfaction, they are rinsed with clean water and dried. While pickling for the purpose only of causing the color peculiar to gold to appear, the process of coloring has for its object to lend the

appearance of very fine gold to an article of an indifferent alloy. Various mixtures may be employed for the purpose, and we give two receipts below which are very appropriate:

Mix two parts saltpeter, 1 part table salt and six parts alum with $6\frac{1}{2}$ parts water, and place in a porcelain dish for heating. As soon as you notice that the mixture begins to rise, add 1 part of muriatic acid, raise the whole to boiling and stir with a glass rod.

The article to be colored, and previously treated with sulphuric acid, as specified, is suspended to a hook, either of sufficiently thick platinum wire or glass; it is then introduced into the rather slow boiling bath, and moved around in it. It is to be taken out in about three minutes, and rinsed in clean water, inspecting its color at the same time. If not to satisfaction, it is returned to the bath, and this withdrawing it or introducing is repeated until the desired color is obtained. By the latter immersions the article is left only one minute at a time in the fluid.

When sufficiently colored the article, after rinsing, will be of a high yellow and mat color; it is washed repeatedly in water to remove the last traces of the bath, and then dried in hot boxwood sawdust.

In place of drying in sawdust the article may also be dipped in boiling water, leaving it in for a few seconds; the adhering water will evaporate almost instantaneously.

The second coloring method consists in pouring water over a mixture of 115 parts table salt and 230 nitric acid, so that the salt is dissolved; it is then to be heated until a dry salt residue is again present. This residue is mixed with 172 parts fuming muriatic acid and heated to boiling for which purpose a porcelain vessel is to be used.

As soon as the pungent odor of chlorine gas begins to evolve, the article to be colored is immersed, and left for about eight minutes in the fluid for the first time; in other respects, a similar treatment as specified above, is also used for this method; if the article colored was polished previously, a subsequent polishing is unnecessary.

On account of the vapors evolved by the coloring baths, which are very dangerous to health, the operations should be performed either under a well-drawing flue, or what is still better, in open air.—*Goldsch Miedekunst.*

Polishing Agents. Various polishing agents are used by watchmakers, jewelers, gold and silversmiths, a few of which are here described. Where the article will admit of it, the best results are obtained by polishing in the lathe. For this purpose the watchmaker should not use his regular lathe, but should have for the purpose what is known as a polishing lathe, fitted with its various attachments in the shape of scratch-brushes, buffs, etc.

Ferric Oxide. This material is used in its natural state and also prepared artificially under various names, such as crocus, red stuff and rouge

It is used for polishing fine articles of steel, gold, silver, copper and bronze.

Tin Putty is an artificial compound prepared from glowing oxalate of tin, which is obtained by decomposing tin salt with oxalic acid.

Tripoli. A gray-white or yellowish powder, which is made from the shells of microscopic organisms. It is used for polishing soft metals, first with oil, and then dry.

Lime. This material is used in the burned and unslaked state. A popular variety is known as the Vienna lime. See that heading.

Belgian Polishing Powder. This powder is used for polishing articles of silver and silver plated ware. It consists of a mixture of 250 parts of whiting, 117 parts elutriated pipe-clay, 62 parts white lead, 23 parts white magnesia, and 23 parts rouge.

English Silver Soap. This mixture, which is used for polishing silverware, is prepared as follows: Dissolve 2 parts of castile soap in 2 parts of soft water over a fire; when melted remove and stir in 6 parts of fine whiting, pour into moulds and allow it to cool. A little rouge may be added as coloring matter if desirable.

English Silver Paste. Three parts of perfumed vaseline, 5 parts of whiting, 1 part of burnt hartshorn, and one of pulverized cuttle bone. Stir well and put up in tin boxes.

Gold Polishing Powder. Mix together 4.3 parts of alumina, 17.4 of chalk, 4.3 of carbonate of lead, 1.7 of carbonate of magnesia, and 1.7 of rouge.

Polishing Paste for Brass. Dissolve 15 parts of oxalic acid in 120 parts of boiling water and add 500 parts of pumice powder, 7 of oil of turpentine, 60 of soft soap, and 65 of fat oil.

The polishing agent is usually mixed with oil, alcohol or water to prevent scattering, and is then applied by the polishing tool in the shape of cloth and leather buffs, polishing files, etc. Either the work or the tool should revolve with great velocity in order to secure good results. Many articles are brought to a high degree of polish by the use of the burnisher, after subjecting them to the action of the ordinary polishing agents. See *Burnisher*, also *Buff*.

Scratch Brushing. Articles in relief which do not admit of the use of the burnisher are brightened by the aid of the scratch brush. The

shape of the brush varies according to the article to be operated upon. Hand scratch brushes are sometimes made of spun glass, with fibres of extreme fineness and elasticity, and are used for scouring only very delicate objects. They are also made of numerous wires of hardened brass and are prepared in similar form to the glass brushes, except when purchased the ends of the wires are not cut off, the operator being expected to do so before using them. The object in leaving the wires connected being to prevent them becoming damaged. Circular scratch brushes, in which the wires are arranged radially, are used for scouring articles which will admit of their use. They are attached to the spindle of a polishing lathe, and the wires consequently all receive a uniform motion in the same direction. Scratch brushes are seldom, if ever, used dry, the tool and the work being constantly wet with a decoction of soap-root, marshmallow, cream of tartar, alum or licorice root. With small articles the scratch brush is held as you would a pencil, and is moved over the articles with a backward and forward motion. The brushes must be carefully looked after and the wires kept straight and in good order. If they become greasy they are cleansed in caustic potash, and if they become rough they are sometimes dipped into nitric acid. With circular brushes it is well to reverse them occasionally in order to change the direction of the wires. Dirty polishing leathers should be cleaned by soaking them for an hour or two in a weak solution of soda in warm water, first rubbing the leather thoroughly with soap. Rinse thoroughly and wash in soap and water. The soap in the water will keep the leather soft and pliable. Dry it in a towel and rub it thoroughly and your leather will be much better than any new one you can buy.

CLEAT. A narrow or thin piece of metal used to fasten two pieces of metal together by the aid of solder, screws or rivets.

CLEMENT, WILLIAM. A London clockmaker, who in 1680, laid claim to the invention of the long or royal pendulum.

CLEPSYDRA. A water clock. A machine used anciently for measuring time by means of the discharge of water through a small aperture. The Egyptians divided the space between sunrise and sunset into twelve hours, known as day, and between sunset and sunrise into twelve others, known at night. The days and nights therefore varied according to the seasons, so that the artificial divisions varied in like proportions, rendering the task of inventing a mechanism capable of being retarded or accelerated quite a formidable one for the mechanic of that day. The clock illustrated in Fig. 86 was so constructed that its aperture was adjusted as the year advanced by the attachment of an index to the sun's place in an ecliptic circle. It consists of a reservoir, *A*, at the top of which will be seen a waste pipe, to carry off the superfluous water

and thus keep the level the same at all times. From this reservoir projects a pipe, *B*, which connects with the rim of a drum, *M, N*, on the front of which is a circle with the signs of the ecliptic engraved upon its dial. Fitting inside this large drum is a smaller one, *O, F*, having an index attached to it. This drum has a groove or slot, *a, b*, cut through it, tapering in breadth both ways to a point. This tapering groove, when the parts are in their places, comes just under the end of the pipe leading from the reservoir. This smaller drum turns upon the pipe *F*, which is continued within and has a funnel attached for receiving the water as it drops through the groove in the drum. The index or hand is double, *L* for day and *O* for night, and it will be evident that as it is turned the

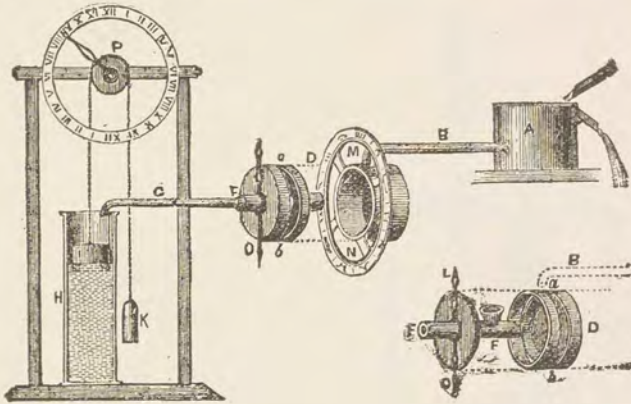

Fig. 86.

capacity of the orifice is altered and the water is regulated to pass more or less rapidly through the pipe. The ecliptic being properly divided, the hand was set to the proper sign in which the sun then was and was altered as it shifted around the ecliptic. The water, after passing through the regulator and the pipe *C*, dropped into the cylinder *H*, in which was a float *I*, connected by a chain passing over a pulley on an arbor *P*, and having a counter-poise weight *K* attached to its other end. To the pulley was attached a hand which pointed to the hour on the circular dial.

A water clock, made by Ctesibius, is illustrated in Fig. 87. The water dropped into a funnel *A*, and was conveyed to the reservoir by means of the pipe *M*. In this cylinder was located a float, to which was attached a light pillar, on top of which was a figure pointing to the hour upon a column opposite. Attached to the bottom of the water cylinder was a small pipe, bent in the form of a syphon, as shown at *E B F*. As the

water rose in the cylinder it also rose in the small pipe until it reached the top, when it flowed over the bend, thus filling the syphon, and by a well known law it quickly emptied the cylinder, the float and figure falling as the water receded. In order to overcome the obstacle of hours of a varying length, the inventor very cleverly drew the divisions on the column out of horizontal, so as to vary in their distance on different sides of the column. As the water came from the syphon it fell into receptacles in a wheel, shown at *K*, which, turning with the weight, as each compartment filled, caused the cylinder to revolve by the action of

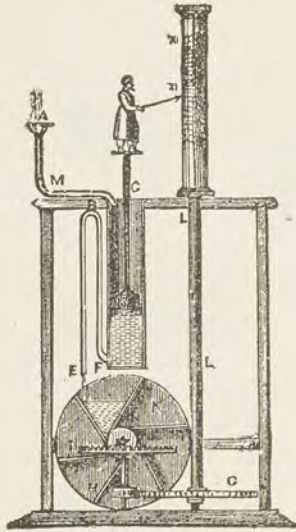

Fig. 87.

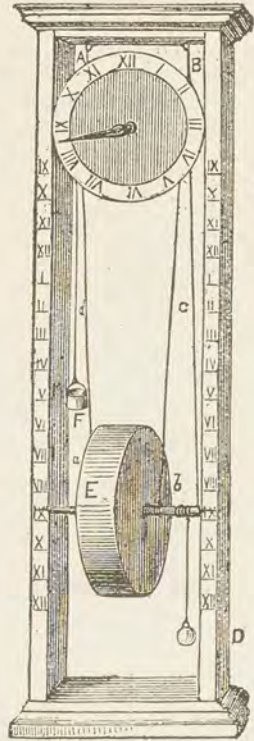

Fig. 88.

the pinion on its axis, taking into the contrate wheel *I*, which by another pinion *H*, turned the wheel and shaft *G* and *L*. In this way a variable scale of divisions was presented to the index, the space being regulated by the number of teeth in the wheels. Authorities differ as to the date of the revival of the clepsydra, one authority placing the date at 1646, while another gives it as 1693. A clepsydra of the seventeenth century is illustrated in Fig. 88. It consisted of an oblong frame of wood, *ABCD*, to the upper part of which two cords *Aa*, *Bb*, are fixed at their superior extremities and at their inferior are wound around the axis of the drum *E*. This drum was divided into several water-tight compartments, as

shown in Fig. 89. The cord was wound around the axis until the drum was elevated to the top of the frame and it was then left to obey the force of gravity. A hole was pierced near the bottom of each compartment, allowing the water to slowly ooze from one compartment to the other, thus causing the drum to revolve with a certain degree of accuracy. The rate of motion was regulated by altering the size of the apertures. The hours were indicated in two ways; one by the axis pointing out the hours on the side of the frame as it revolved, and another by passing a cord, *c d*, over a pulley attached to an arbor, having an index or hand to point out the hours on a dial, a weight, *F*, being fastened to the other end of the cord.



Fig. 89.

CLERKENWELL. One of the great watch and clock centers of England. It is one of the parishes of London, and within its limits every branch of the watch trade is carried on.

CLICHE. The forming of metal objects by means of forcing a die into heated metal.

CLICK. A pawl or dog which falls into a ratchet wheel and prevents it from turning backward, and is usually held in position by means of a spring, known as the click spring. A ratchet wheel with click is fixed to the barrel arbor of watches and clocks to maintain the main-spring after being wound.

Click Spring. The spring which holds the click in position on a ratchet wheel's tooth.

To Mount a Click Spring. When the old click spring has been taken down from the bridge, find a new one, which, in length from click to foot, into which the holes are drilled for fastening, is suited to the shape and length of the bridge. With three claws fasten this latter in an uprighting tool, placing the centering center into the screw hole of the bridge, which serves for screwing on the click spring. When the bridge has in this manner been mounted well upon the plate of the uprighting tool, raise up the centering center and lay the new click spring exactly as it is to be located in its place upon the bridge, carefully preventing the claws from covering that part of the bridge to which the spring is fastened. The upper face of the spring must, by so much as will be lost afterwards in grinding and polishing, protrude beyond the surface of the barrel bridge. Then retain the spring in its place by

applying a finger, and lower the point of the uprighting tool upon the click spring, making a dot by applying a gentle pressure exactly at the true spot. This dot is enlarged by punching, and a hole is then drilled exactly to suit the size of the screw. The burr is next removed, and the spring finished suitable to shape and length. If the bridge contains a foot pin hole, bush it by firmly driving into it a brass pin, file off its projecting part level with the bridge, and screw the spring in place. Then drill, as closely as possible, to the extreme end of the spring, a small hole for the pin, clear through into the bridge. Harden the spring, anneal it, chamfer and polish the edges, grind and polish the surface; fit the foot pin.

CLOCKS. It has been a matter of no small dispute as to who first invented clocks employing a weight for the motive power. Pacificus, Archdeacon of Verona, is said to have constructed a clock in 850 A. D., which marked, besides the hours, the days of the week, the phases of the moon, &c. Bailly, in his history of Modern Astronomy, argues very forcibly in favor of Pacificus, saying that he was the inventor of an escapement, in which the inertia of a balance was employed to retard and regulate the movement of a train of wheels moved by a weight. Father Alexandre, the author of a treatise on clocks, decides against Pacificus as the inventor of the weight clock, and Berthoud is of the same opinion. Nelthropp, in his treatise on watch work, says that it is more than probable, almost certain, that to the Moors of Spain the world is indebted for the great advance in clock work, and that from Cordova, Granada and Barcelona went forth the ideas which gave birth to the weight as a motive power, instead of water. Nelthropp is of the opinion that the inventor of the weight clock was one Gerbert, who was born in 920, A. D., in the village of Belliac in Auvergne. Certain it is that in 996 he made a clock for Madgeburg, which writers agree in stating had a weight for the motive power. After various ups and downs he became Pope, under the name of Sylvester II., in the year 999.

According to Stowe, a clock was erected near Westminster Hall, out of a fine of 800 marks imposed upon Ralph de Heugham, Chief Justice of the King's Bench, in 1288, A. D. In 1292 a clock was erected in Canterbury Cathedral, by Henry, the Prior. In 1317, a clock was erected in Exeter Cathedral. In 1326, Richard Wallingford, Abbot of St Albans, constructed for the abbey a clock, which, Leland says, showed the course of the sun, moon and planets, and the rise and fall of the tides. In 1344 a clock was constructed for Padua by a workman named Antoine, after the designs of Jacques de Dondis. In 1348, a clock was constructed for Dover Castle, with wheels and frame of wrought iron; escapement, a crown wheel acting on pallets fixed to a verge, the upper end of which was suspended to a cock by a piece of cord, so as to hang perpendicular; lower end, a pivot working into a kind of stud attached to frame;

balance, an iron bar, each end terminating in an elbow, to which a weight was attached in order to produce an equilibrium.

The first Strasburg clock was begun in 1352, and completed two years after, by John Bishop, of Lichtenberg. The second clock was begun in 1547, by Dr. Michael Heer, Nicholas Bruckner and Christian Herlin, professor of the University of Strasburg, and one of the most distinguished mathematicians of his time. Owing to the death of the Colleagues of Herlin, the work was not completed until 1574. In 1570,

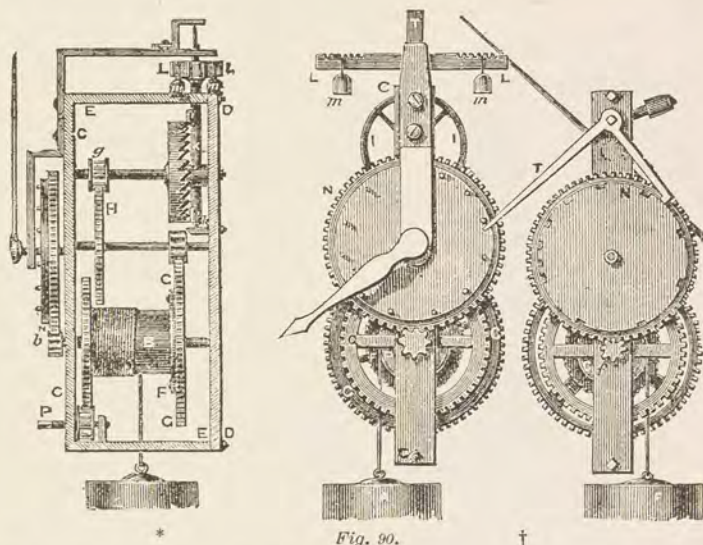

Fig. 90.

Conrad Dasypodius, a disciple of Herlin, reconstructed it on a larger scale. The mechanical work was performed by Isaac and Josiah Habrecht, clock-makers of Schaffhausen, Switzerland. This clock, which was restored in 1669, by Michael Isaac Habrecht, grandson of Dasypodius, one of the original makers, and a second time restored by James Straubharr, in 1732, ceased to act in 1789. The present Strasburg clock was commenced June 24, 1838, and started running on October 2, 1842.

In 1370, Charles V., King of France, caused to be made at Paris, a large

*Side view of Time Train. B, Barrel; C, D, E, Plates; F, Ratchet and Click; G, Great Wheel; P, O, Winding Pinion and Wheel; H, Second Wheel; g, Escape Pinion; b, Pinion driving Hour Wheel; N, Hour Wheel, the arbor of which carries the hand.

†Front view of Time and Striking Train. K, Verge; L, Balance; m, Shifting Weights for adjusting the Clock to time; N, Count Wheel or Locking Plate; T, Lever for letting off Striking Work.

turret clock, by one Henry de Vick, (sometimes spelled De Wyck), a clockmaker of Wurtemberg. He took eight years to complete the work. John Jouvaunce cast the bell on which the hammer of the clock struck the hours. It was on this bell the signal was given for the massacre of Saint Bartholomew, 1572.

The escape wheel of this clock was a crown wheel which acted on pallets attached to a vertical rod or axis, moving on two pivots; the balance, a heavy bar of iron, was fixed to the upper part of this verge, and had weights placed at corresponding distances on each arm by means of a number of equidistant notches, in order to regulate its vibrations. The upper end of the verge was suspended by a small cord, to a cock fixed to the larger cock, in which the pivot hole was pierced, for the purpose of keeping it perpendicular and decreasing the friction of the lower pivot.

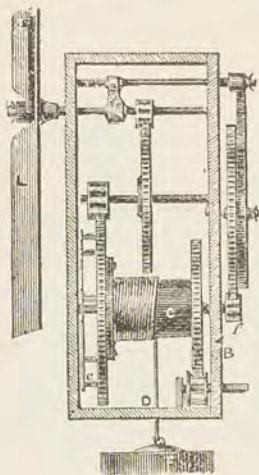

Fig. 91*.

It was originally located upon the clock-tower of the St. Sebaldus Church, and indicated the hours to a watchman, who thereupon announced them to the inhabitants of the city by striking upon a bell in the tower. The hammer used weighed 120 pounds, and was introduced at the same time as the great bell *Benedicta*, in the year 1392. This clock is constructed entirely of iron, and is $15\frac{3}{4}$ inches high. The dial, which is also constructed of iron, is 11 inches in diameter. The clock when first discovered had a painted dial with twelve hours upon it, but Speckhart was aware that this was not the original dial because on the outer circumference of the dial, he found sixteen nails, one with a sharp pointed head, corresponding to the figure 12 and fifteen with round heads. On carefully removing this paint, he found another dial with twelve hours recorded, and on removing this he came upon the original dial which was painted with sixteen Roman figures of a gothic form. The original division of the day and night was into 16 hours, since the

*Side view of Striking Train. F, Weight; A, B, Plates; C, Barrel; c, Pins for raising the hammer tail; L, Fly; f, Pinion for driving Count Wheel.

longest day, as well as the longest night, has sixteen hours. It is supposed that the nails were used by the watchman in determining the hour without the use of a light, and that he first sought the nail with the point, then felt downwards, counting the others, until he arrived at the nail above which the hand rested. When the day was divided into twice twelve hours, about 1560-1580, the old hour wheel was removed and

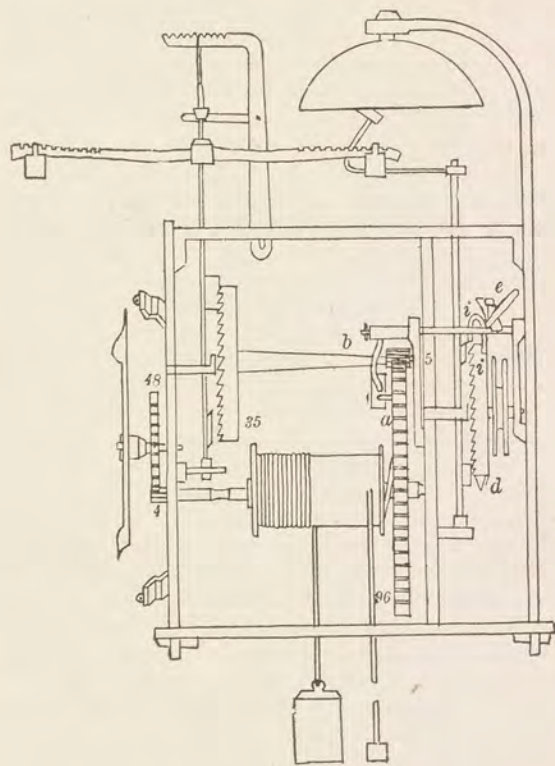

Fig. 92.

replaced by a new one, and the dial was repainted to correspond. The clock has no striking work proper, but as shown in Fig. 92, is provided with a kind of alarm, which after each hour, rattles the hammer to and fro on a bell, to call the attention of the watchman. The motion work consists of a barrel wheel with ninety-six teeth; a vertical wheel with thirty-five teeth, and a five-leaf pinion. The barrel wheel has a four-leaf pinion, seizing into forty-eight teeth of the hour wheel. In the former division of sixteen hours the hour wheel had sixty-four teeth.

The verge is suspended by a cord, and in lieu of a balance, is provided with a horizontal toothed bar, on the ends of which hang two small weights, for regulating purposes. The winding part is peculiar, because, while the cord with the heavy weight descends, another cord with a small weight winds up in an opposite direction, and it is only necessary to draw down the small weight in order to wind up the heavier.

A pin *a* is inserted in the barrel wheel, which makes one revolution every hour; this pin unlocks the lever *b* and actuates the alarm; but since it was thought necessary to prolong the alarm for about one-quarter of a minute, the following arrangement was introduced: While the lever *b* on the movable part *c*, is raised up by the pin *a*, it liberates the wedge *d*, which, when the alarm is at rest, leans on the lever arm *e*, so that the alarm wheel, with one winding, sets the hammer into activity. Ordinarily it would take some time for the pin *a*, with its movable part *c*, to pass the lever *b*, and the alarm would in consequence run down with the first ringing. To prevent this, the angle *i* is riveted to the circumference of the alarm wheel, opposite to the wedge *d*, which after a half revolution of said wheel, still lifts up a part of the lever arm *e*, so that the part *c* falls downward by its own weight, and leaves the pin *a* free, so that the lever arm *e* again assumes its place upon the face of the alarm wheel, and the wedge *d*, in its further half revolution, places itself against it in order to place the alarm into repose, until the performance is again repeated.

An astrological clock, bearing the date 1525, is in the museum of the Society of Antiquaries, London. It was made by one Jacob Zech, of Prague, and Nelthropp, after investigation, is of the opinion that it was once the property of Sigismund the First, King of Poland. The wheels of this clock are made of iron. It is fitted with a powerful expansive spring, coiled in a drum or barrel, and has a hand-made fusee for equalizing the variable power. The balance consists of an iron bar carrying a screw at each of the ends, with tapped weights of lead. At present the barrel is connected with the fusee by a chain, but there is every reason to believe that in the original construction a catgut or cord was used. The escapement is of the verge and crown wheel type.

In 1532, Henry, the Eighth, presented to Anne Boleyn, on their marriage, a clock of beautiful construction which is now in Windsor Castle. There is a clock at Hampton Court Palace bearing the date 1540, and the initials N. O.

There is a clock at Berne, Switzerland, constructed by Gaspard Brunner, a locksmith, but improved and repaired by Angely, a French clock-maker, in 1686.

In 1758 James Ferguson invented what was known as the "Simple Clock." Fig. 93 illustrates the dial and wheel work of this clock. It showed the hours, minutes and seconds, by means of only three wheels and two pinions. The great wheel contained 120 teeth and turned around in twelve hours, and on its axis was the plate on which the

twelve hours were engraved. This wheel turned a pinion of ten leaves and the minute hand was on the axis of this pinion. On this axis was also a wheel of 120 teeth which geared into a pinion of six leaves, and on the axis of this pinion was a wheel of 90 teeth, going around in three minutes and keeping a pendulum in motion that vibrated seconds, by

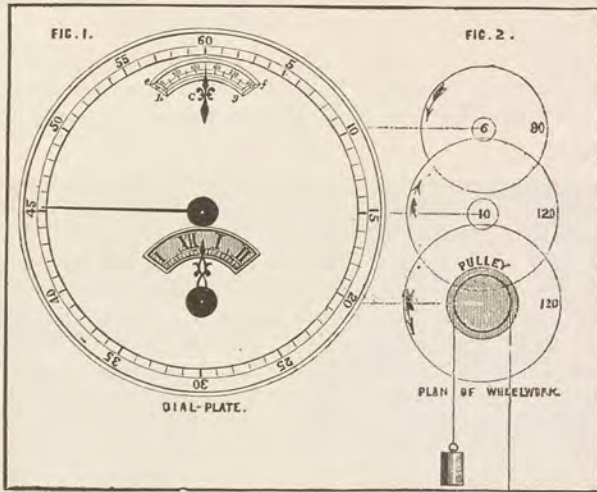

Fig. 93.

pallets, as in a common clock, where the scape wheel has thirty teeth and revolves in a minute. As this wheel only revolved in three minutes it was necessary, in order to show the seconds, that a thin plate be fastened to the axis and divided into 180 equal parts, and divided as shown in the illustration, 10, 20, 30, 40, 50, 60; 10, 20, 30, etc.

Annual and 400 Day Clocks. These clocks are made to run much longer than usual with one winding, by simply interposing a number of gears and pinions between the barrel and the usual train, and using a longer and stronger spring to overcome the increased friction in the train. These clocks are usually provided with torsion pendulums. They are made chiefly as curiosities.

Astronomical Clock. A clock having twenty-four hours shown on the dial and a pendulum of such length as to show stellar time, which is three minutes, fifty-six seconds shorter than the mean solar day. Also called sidereal clock.

2. A clock, or orrery, showing the comparative motion of the heavenly bodies, by means of concentric discs, rotating proportionately on a central arbor which also carries the ordinary clock hands.

Calendar Clock. A clock which shows the progress of the calendar. In a simple calendar the mechanism has to be adjusted at the end of all months having less than thirty-one days. In a perpetual calendar the correct indications during short months and leap years are performed without adjustment.

Carriage Clock. A European term for a clock having a balance instead of a pendulum, so as to be readily portable.

Chiming Clock. A clock which plays tunes on bells, rods or by connection with a musical box. Church clocks are often arranged to chime on bells, while mantel clocks are generally connected with a

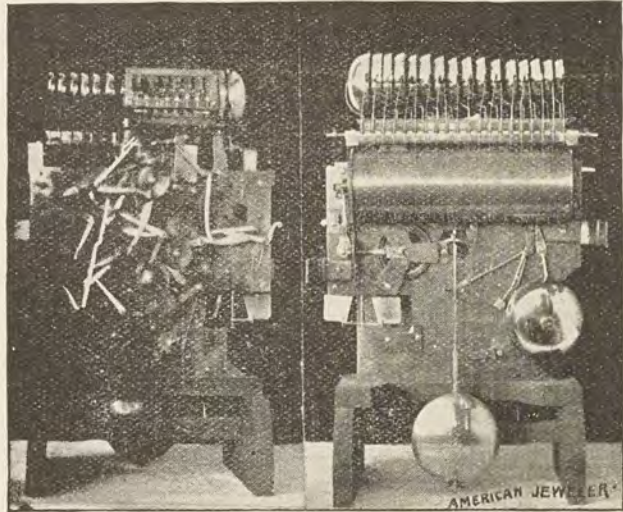

Fig. 94.

music box. Fig. 94 illustrates a chiming clock made by Eardley Norton, a celebrated maker of musical clocks, who carried on business in London from 1765 to 1800.

Clock Watch. A watch which automatically strikes the hours.

Electric Clock. A clock operated by a weight or spring and having a pendulum, which is controlled by electrical currents transmitted automatically by a master clock. 2. A clock in which the winding is performed by electricity, by means of a motor placed in the case. Fig. 95 illustrates the mechanism of an electric clock made by Mr. F. Lorenz, which has many novel features to recommend it. It con-

sists of a brass, German silver, or other metal back plate *A*, made sufficiently heavy to support the entire weight of the movement and pendulum in a proper manner. The pendulum, which beats seconds, is supported by an arm *B*, in the usual manner, and is composed of

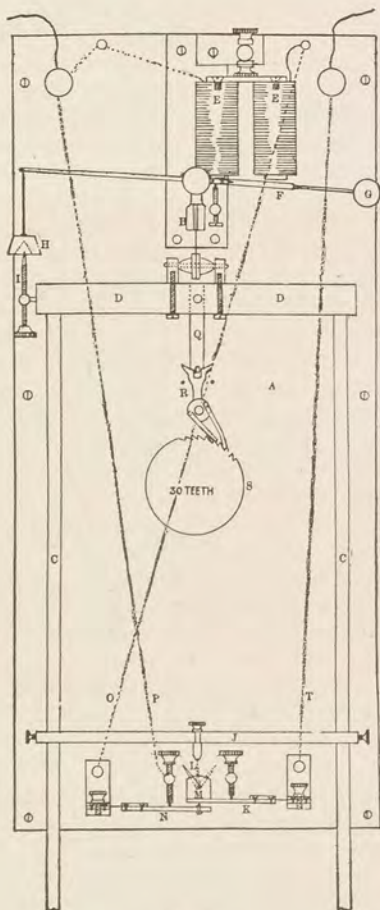

Fig. 95.

steel rods *CC*, held by brass bars *DD*, and adapted to carry glass jars of mercury, with a rating nut at the lower end, in the usual form. A three-ohm electro-magnet *E* is suspended from the upper part of the plate as shown, and beneath it is an armature *F*, which is carried on a pivoted lever having a counter balance weight *G*, at one end

and an impulse weight H , at the other. An adjusting screw is provided beneath the armature to retain it within the influence of the magnet. Attached to the bar D , of the pendulum and oscillating with it, is an adjusting screw I , which receives the blow from the impulse weight H , and imparts the momentum to the pendulum. This weight, which weighs thirteen pennyweights, is suspended from the armature lever by a silk cord, and acts upon the pendulum every 58, 60, 62 or 64 seconds, according to the amount of pressure in the atmosphere. At the lower end of the plate is shown the escapement. The bar J , is carried upon the pendulum rods, and has at its center a pillar which carries a ruby jewel, having a groove cut in its face at right angles to the plane in which the pendulum swings. Beneath this is an oscillating lever L , carried upon an arbor which is fitted in jeweled holes in a pair of upright plates M . This lever is made of gold, tipped with irridium, (the hardest known metal), and has its lower end enlarged to form a disc about the center of the arbor. Upon this disc are placed two guard pins which prevent the uncoiling of the hairsprings. At suitable points in the plate M , are placed two banking pins which prevent the lever from moving too far by striking against the projecting outer ends of the hairsprings. The hairsprings are mounted on the arbor so that one coils to the right and the other to the left, and are so adjusted that the recoil of either will throw the oscillating lever to the same side as that upon which the spring is coiled. Thus, when the jewel is carried past the lever it presses upon it sufficiently to coil one hairspring so that the recoil will reverse the lever. On the return motion, the reverse happens, and this is kept up until the arc of the pendulum has decreased so much that the jewel is no longer carried past the lever. When this occurs, the irridium point of the lever enters the groove of the jewel and the momentum of the pendulum pushes the plates M and the spring bar K downward, out of its path, thus making electrical contact between the spring bars K and N , and closing the circuit, which operates the magnet E , the armature F , and the impulse weight H , and gives renewed impulse to the pendulum. Attached to the center of the pendulum bar D , is a lever Q , carrying at its lower end a roller jewel which works in the fork R , to operate two pawls which are hung eccentricly upon the fork arbor, and actuate a ratchet wheel S , with 30 teeth. The ratchet wheel arbor carries on its outer end a pinion which meshes with the hour and minute wheels in the usual manner, and also bears the seconds hand. As the length of the pawls is such that the ratchet wheel moves one-half tooth at each vibration of the pendulum, this gives a center-seconds motion direct from the ratchet wheel arbor. The clock is operated by two cells of sal ammoniac battery, the wires from which enter the case and are passed behind the back plate by means of binding screws as shown.

The current enters on the wire *T*, and is conveyed to the spring bar *K*, through the insulated arm as shown. This arm, which carries the oscillating lever *L*, is adjusted so as to remain .3 mm. from the arm *N*, which is similarly insulated and from which runs the wire *O*, connecting with the magnet *E*. A wire *P*, is connected with an adjusting screw which presses upon the bar *N*, and the points of contact upon the bars *K* and *N* are tipped with platinum. When *K* is depressed by the pendulum acting on the lever, the circuit runs through *T*, *K*, *N*, *P* and *O* for about .01 second; then as the depression continues, *N* is removed entirely from the contact with *P*, and the entire current follows the line *T*, *K*, *N*, *O*. This prevents sparking between *K* and *N*, and also prevents induced currents in the magnet. The important feature of this clock, aside from its simplicity, is that the arc of the pendulum cannot decrease beyond that for which it is adjusted, as the action of the impulse weight and oscillating lever cannot vary, which feature renders the timekeeping qualities of this clock far superior to that of any weight clock.

Equatorial Clock. A clock which drives an equatorial telescope.

Equation Clock. A clock invented about the end of the seventeenth century, which contained a device for partially rotating the dial, so as to make the length of the day indicated by the clock, coincide with that of the solar day.

Locomotive Clock. A clock adapted to be carried in the cab of a locomotive, and so constructed as to withstand the jarring and heat variations of the temperature. They are usually made with detached lever escapement, jeweled, like a watch, and compensated for temperature.

Master Clock. A clock which is carefully regulated and used to correct others, by electricity or otherwise. 2. The original clock model from which others are made.

Pneumatic Clock. One of a series of clocks governed by pulsations of air, sent to them at regular intervals through tubes which are controlled and operated by a master clock.

Repeating Clock. The mechanism by which a clock or watch may be made to strike the hours and minutes by pulling or pushing a cord or rod, so as to tell the time without looking at the dial, was invented in 1676 by Wm. Derham. It immediately became popular, and the idea was taken up by many English, French and German horologists. It was at first applied only to clocks, but was subsequently put into

watches as well, and forms the origin of the repeating watches of the present day.

Watchman's Clock. A clock having a paper dial, which is used to control the movements of a watchman by means of keys fastened to short chains at various portions of his beat. The various keys operate variously shaped punches which perforate the dial, and thus show the time of his presence at any particular station.

Clock Repairing and Cleaning. Of all timekeeping mechanisms, the ordinary household clock has probably passed through the greatest variety of experiences, from that bordering on the mysterious down to those when the watchmaker's apprentice for the first time attempts to make the thing go. How fearfully and wonderfully the clock is made, is now, to him, for the first time a stern reality, a thing which must be conquered and subdued. While the clock, as a rule, is stronger and consequently can withstand the rough handling of an apprentice, his efforts should, however be guided by an experienced hand. When a clock is brought in for repairs the first thing is to examine the movement thoroughly, either before or immediately after removing it from the case, according to the style of clock, and in which position the examination can be best conducted. If, as is sometimes the case, a clock has been running for some time, and is so dirty that a satisfactory examination cannot be made, it should be cleaned, to permit of examining, by the use of gasoline, which will quickly remove the old oil and dirt. If many repairs are necessary, a list of them should be written down on a piece of paper, so that nothing may be overlooked when it comes to doing the actual work of repairing. When examining the movement it should be noticed that all the wheels are free, the depths correct and the wear on the pivots and pivot holes, which if excessive must be corrected by refinishing the pivots and bushing the holes. Sometimes a new pivot, or perhaps a new arbor will be needed to correct the fault entirely. Having examined the train, the escapement must be carefully scrutinized, as it is here that any slight inaccuracies or wear will be the most detrimental. The pivots of the escapement should fit the hole with only a sufficient amount of play for freedom. Notice if the pallets are pitted even slightly, and if they are it will be necessary to regrind and polish them so as to leave them perfectly smooth. The escapement should be set as close as possible, noting that the drops are equal upon each pallet. Notice the teeth of the escape wheel that they are not bent, a fault very likely to occur with some forms of teeth. Where the crutch strikes, the pendulum rod should be examined, and if worn it must be smoothed off. The crutch itself should fit the rod freely, but without play. If the clock

is regulated from the front, and has a slide working along the suspension spring, this slide should fit the spring accurately, so that while there is no binding there is no lost motion. If the action of the striking train is correct each pair of wheels and pinions may be marked by a small dot, so that after the movement is taken apart the pieces may be assembled as before. If it is a spring clock the mainspring must be let down before the movement is taken apart. The above general remarks apply equally well to all kinds of clocks, but in addition to these there are several kinds, a full description of which would be beyond the range of this book, since the matter necessary for a complete description would be sufficient for a separate volume, consequently we must advise that the action of the mechanism be studied until thoroughly understood before attempting to repair any of the more complicated clocks. A great many workmen are content to immerse the parts of the movement in benzine or gasoline (which is about the same thing as usually sold), but the substance, while good for removing the old oil, does not leave the parts in good condition for the preservation of the oil, a very necessary and important thing, sometimes giving trouble even with the greatest possible care.

In the better grades of clocks the same care should be exercised as in cleaning a watch. Have the pivots and pivot holes thoroughly cleaned, if the cleaning is done by benzine, so as to remove every trace of it from them. The mainspring, if the clock has one, must be cleaned and the old and gummy oil removed thoroughly. When a clock is running a noise is sometimes heard which is caused by the coils of the mainspring sticking together on account of the old oil which has become so gummy as to absorb a good portion of its power, and as the spring unwinds, the coils slip upon each other. When the mainspring is mounted in a barrel it should be tested to see that it is true by twirling it upon its arbor. If the test shows it to be untrue, one or both of the holes should be bushed and uprighted. The teeth of the various wheels must be examined to see if any are bent. The depths must be correct, and this may be tested, by putting the one which is suspected in the plates and by holding a piece of pegwood upon the pinion arbor so as to make it turn quite hard, the correctness of it when the power of the mainspring is on may be judged. In cleaning French or other clocks where the brass is polished and has become tarnished, the brass may be cleaned by using a stiff clock brush moistened in a solution of cyanide of potassium in the proportion of about one ounce of the cyanide to a quart of water. After the brush is moistened dip it in prepared chalk or other good polishing powder, and by brushing the tarnish may be easily removed. Another brush should be at hand which is perfectly dry and clean, with which follow the cyanide brush,

for if the solution is too strong, or is left on too long, the action of the cyanide on the brass will be to blacken it, thus the work will be no better than it was before. The teeth of the wheels and the leaves of the pinions, if rough or rusted, should each be carefully polished and cleaned. It is certainly a disgusting sight to see a movement that is well made and polished left covered with finger marks and tarnish which has become so thoroughly fixed as to be very difficult to remove. No workman who is at all worthy of the name of watch or clockmaker should think for a moment of allowing such a job to leave his hands. When putting the movement together, after the various pieces are in place, the top plate may be put on and held loosely in place by a screw or pin in one of the pillars. When the movement is in the case it should be set upon a level place and the escapement adjusted until the beats are equal. After the clock is set up it is to be timed, and if at first there is any great gain, it may be corrected at once, but after it runs for some time with no perceptible variation, it should be allowed to run a longer and longer period of time, until it runs from one winding to another before making an alteration, this being especially so when the motive power is a spring, as these will vary between windings.

CLOCKMAKERS' COMPANY. In 1631 the clockmakers residing within the liberties and suburbs of the city of London petitioned the crown for a charter incorporating all the clockmakers, both free and foreign, who practiced clockmaking in the city of London, and ten miles compass, by the name of the Master, Wardens, and Fellowship of the art or mystery of clockmaking of the City of London, constituting them one body corporate and politic in deed and name, to have and continue forever.

CLUB TOOTH. The form of tooth shown in Fig. 223 and for lever escape wheels, having a part of the impulse angle on the tooth. See *Lever Escapement*.

CLUTCH. A mechanism for connecting two shafts with each other, or with wheels, in such a manner that they may be readily disengaged.

COCK. The horizontal bracket which holds the end of a staff. A vertical or hang-down bracket is called a potance. See *Balance Bridge*.

COLE, JAMES FERGUSON. An able watchmaker and expert springer of London. He devoted considerable attention to the lever escapement, and devised several forms of it. He was born in 1799 and died in 1880.

COLLET. A collar or band of metal. 2. A small collar fitted friction tight to the balance staff, and which is slotted to receive the lower end of the hairspring. 3. The part of a ring in which a stone is set. 4. The under side of a brilliant cut stone.

COLLET WRENCH. A tool for twisting a hairspring collet to position, which consists of a metal handle, hollow at the extremity for the reception of the pivot, and having a minute wedge-shaped projection from its face, which enters the slit in the collet, allowing it to be turned readily.

COLORING GOLD ARTICLES. See *Cleansing, Pickling and Polishing*.

COMPASS. An instrument consisting of a magnetized needle turning freely on a point, used to determine horizontal directions in reference to the cardinal points.

COMPASSES. An instrument for measuring figures, describing circles, etc., consisting of two pointed limbs usually pivoted together at the top.

COMPENSATION The correction of the effect of variations of temperature on the vibrations of the balance or pendulum. The first person, says Nelthrop, who seems to have observed that metals changed their length, by changes of temperature, was Godfroi Wendelinus, Canon of Conde, in Flanders, about the year 1648. John Ellicott, a watchmaker of London, invented a pyrometer, for testing the expansions and contraction of metals, about 1740. About the year 1715, Graham endeavored to make a pendulum rod that should counteract the effect of heat and cold, but did not succeed. In 1722 he made a clock with a mercurial pendulum, or rather, instead of a metal bob he used a vase filled with mercury which he attached to the end of the rod, which proved quite successful and was the first attempt at compensation. In 1726, Harrison completed his gridiron pendulum, and there is little doubt that he was the first to apply compensation to the balance of a watch, which he did in 1749; but as there is no written evidence, the honor was claimed by F. Berthoud, who in 1766 made a watch with compensation balance, for Pinchbeck, a London watchmaker, for his majesty George III. Nelthrop thus describes it: The compensation piece was made of brass and steel pinned together; one end was fixed to the fore-plate, the other was made to act on a short arm projecting from a movable arbor; a longer arm, having the curb pins in it, moved nearly in the circle of the outer coil of the spiral spring. Mudge invented a compensation for heat and cold, which he applied to his time keepers. His system was more simple than that invented by Berthoud, but acted in the same manner on the spiral spring. He applied it in 1774 to a watch. Abraham Breguet

invented and applied to his watches a V-shaped compensation curb, made to correspond in a great measure with the circumference of the balance. Nelthrop describes it as a curb being made of brass and steel, the brass being inside, and so arranged, by being screwed on to the extremity of the regulating index, that the balance-spring vibrated between one end of it, formed into a heel, and a fixed pin. The action was simple: in cold weather the space between the heel of the compensation curb and the pin, became enlarged, through the contraction of the compound laminae; consequently the balance-spring had more room to vibrate in. In warm weather the laminae expanded, thereby reducing the space, and contracting the expansion of the spring. The defect in this curb was the difficulty of adjustment, which caused it to be abandoned.

Arnold also made experiments in order to try and obtain compensation and finally adopted a method entirely dissimilar to the others by placing the compensation in the balance alone. Arnold was followed by Earnshaw, who in 1802 invented a balance not unlike those in use today.

COMPENSATION BALANCE. A balance of a watch or chronometer which compensates the effect of variations of temperature on the vibrations of the balance. See *Balance*.

Mr. Richard Lange made a series of balances which are herewith illustrated, which give a clearer view of the disadvantages worked under by the pioneer experimentors. In the balance shown at A, Fig.

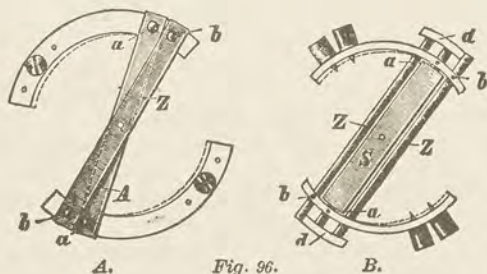

the flat rim is made of brass, the arm *A* of aluminum, the compensating arm *Z* is of zinc. The balance rim is united to the arm at *a* either by rivets or pivots, similar rivets *b b* form the connection for the compensating arm; they are placed quite close to *a a*. In heat the zinc arm *Z* will expand much more than the aluminum arm *A*, and cause the rim to move inwardly, as indicated by the dotted line. Both arms, *A* and *Z* in this case of are equal length; the regulation

of the compensation is effected by a change of position of the adjusting screws.

At B, Fig. 96 the action of the compensation is increased in that the compensating arms ZZ , also of zinc are made double the length of the balance arm S . This is accomplished by attaching to the arm Z , with screws, cross-pieces, dd , of brass, to which are immovably fastened the ends of the compensating arms ZZ ; aa are the pivots of the balance rim, bb the pivots to the joints to the compensating arms. The results are similar, but more effective than shown by A, as by the greater expansion of the compensating arms with an increased temperature the rim will be deflected inwardly, as shown by the dotted lines. The regulation is also effected by a change of position of the balance screws.

Experiments with this balance proved that the compensating action was still insufficient, and at A, Fig. 97 is shown a balance in which this action is further increased. This balance closely resem-

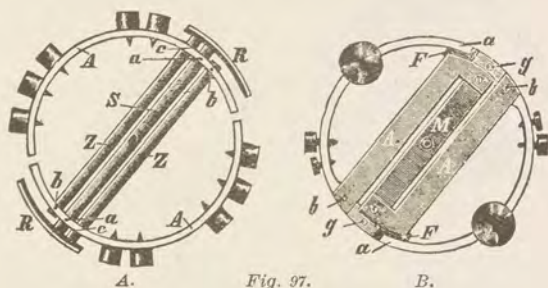

Fig. 97.

bles the one shown at B, Fig. 96, the compensating pieces are made of zinc and rigidly connected with the balance arms and the sectional piece R . The balance rims, AA , will operate in like manner in heat and cold as those at B, Fig. 96. But the sectional pieces in this case are lengthened and composed of two metals, the inner of steel and the outer of brass, and they are also provided with tapped holes for the attachment of weights. In consequence of this form of construction of the sectional pieces RR , a compensating action will take place, inasmuch as their free ends with their screws, if such are required, will during an increase of temperature, take an inward direction, while an opposite action is produced with a fall of temperature. This style of balance can therefore be termed an auxiliary compensation balance. The compensation is effected by, 1st, a change of position of the adjusting screws on the balance rims, AA ; 2nd, by moving the auxiliary screws on RR to a different place, or making them either heavier or lighter.

B, Fig. 97, illustrates a balance with shiftable weights. Here the inner arm *M*, and the rims are made of brass; *g g* are the pivotal connections for the rims. The outer compensating arms *A A*, are of aluminum, and one of the ends is screwed to the arm *M*, the other is pivotally attached to the rim, forming a movable joint. In this style the compensating arms will tend to draw the rims inward, as steel has a greater co-efficient of expansion than aluminum, therefore the joint *b*, will be drawn towards the inner side of *g*. This balance also shows another interesting novelty. The outer ends *F F*, of the arm *M*, are made broad and thin, thus ensuring a secure movement of the slotted ends *a a*, of the rim.

A and B, Fig. 98, show two forms of the true auxiliary or controlling compensation. It is a well-known fact that in the usual rim compensation balance its action in the higher degrees of temperature is

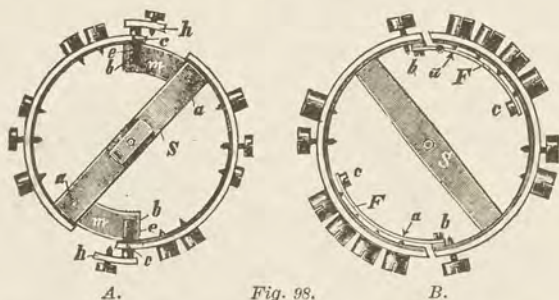

Fig. 98.

not sufficient, and it is necessary in particular cases to apply auxiliary means to accomplish such effects in progressive stages. This is usually done by means of small levers.

A, Fig. 98, shows the lower side of a balance so constructed. At the extreme ends of the balance rims there are small movable brass arms *c c*. The outer ends of these arms have cross-pieces *h h*, forming a continuation of the rims, and are provided with screws. The balance arm *S*, is made of steel; the rim is made in the customary way, steel on the inside and brass outside. On the upper and outer sides of the balance arm *S*, are two broad arched brass pieces *m m*, pivotally connected at *a a*, and they are also movably attached to the ends of *e e* by means of pivots. With a considerable increase of temperature the balance rims will have a strong inward motion, and its influence will be greater on the sectional pieces *h h*, therefore these latter considerably increase the effectiveness of the compensation. In the middle temperatures the movements of the sectional pieces *h h*, in a radial direction, cannot be very much, as the connecting pivots *c* and *b*, in the middle temperatures have the same radii.

At B, Fig. 98, the same results are obtained, but in a different way. The balance is of the usual brass steel pattern, the rim being cut near each of the arms. At the inner end of the immovable (short) rim is screwed a rather long elastic spring F , having at its free end an auxiliary screw C . In the middle temperatures this spring is so curved as to just come in contact with the points of the balance screws. Now, if the balance rims are strongly curved inwardly in high temperatures the point of the last screw at a will move the spring F , and the auxiliary screw c , and as the screw c , whose distance from a is about three times that between a and b , it can be readily seen that the free end of the auxiliary will increase threefold any movement of the balance rims at a , in consequence of which the compensatory action is greatly increased.

COMPENSATION PENDULUM. A pendulum in which the effect of changes of temperature on the length of the rod is so counteracted that the distance of the center of oscillation from the center of suspension remains invariable.

COMPENSATION CURB. A bar composed of two metals, usually brass and steel, free to act at one end but retained at the other, the free end carrying the curb pins that regulate the acting length of a hairspring. Not used in American watches and found only in old watches of European make.

CONCAVE. The internal surface of a hollow a rounded body. The reverse of convex.

CONICAL PENDULUM. A pendulum whose bob moves in a circle. See *Pendulum*.

CONICAL PIVOT. A pivot whose shoulders are of conical form used only in pivots having end stones. See *Balance Staff*.

CONOIDAL. Having the form of a cone.

CONTRATE WHEEL. A crown wheel. A wheel whose teeth are set at right angles to its plane and used ordinarily as a gear wheel for transmitting power from one shaft to another, standing at right angles to it. The escape wheel of the verge escapement.

CONVERSION. A term in watchmaking signifying that a change of escapement is made, as a movement originally having a duplex escapement is changed to a lever escapement.

CONVEX. Rising or swelling into a rounded body. The reverse of concave.

CONVEXO-CONCAVE. Convex on one side and concave on the other.

CONVEXO-CONVEX. Convex on both sides.

COPPER. A metal of a reddish color, malleable, ductile and tenacious. It fuses at 2,000° Fah. and has a specific gravity varying from 8.8 to 8.9. It has a breaking strain of 48,000 lbs. per square inch. In horology it is employed as a backing for enameled watch dials; in the construction of gridiron compensation pendulums; in the manufacture of compensation balances, etc. When mixed with tin it forms bell-metal and bronze and with zinc it forms brass and other alloys. See *Alloys*.

CORUNDUM. The earth alumina, as found native in a crystalline state, including sapphire, which is the fine blue variety; the oriental ruby or red sapphire; the oriental amethyst, or purple sapphire. It is the hardest known substance next to the diamond. The non-transparent variety, dark-colored and granular is known as emery. See *Carborundum*.

CORUNDUM-WHEELS. Wheels faced with corundum, (emery) or made of a composition of corundum and cement. See *Emery Wheels*.

COUNTER BALANCE. A mass of metal placed on the opposite side of a wheel to that to which a crank is attached to compensate for the weight of the latter.

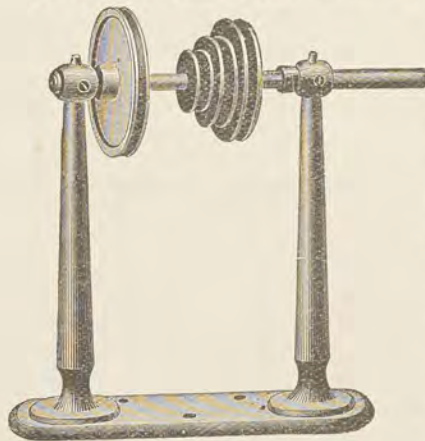

Fig. 99.

Fig. 99 illustrates one of several patterns of countershafts used by watchmakers. In some of the patterns the uprights extend through the

COUNTERMARK. A mark attached to gold and silver-ware of English make to attest its standard. See *Hall Mark*.

COUNTERSHAFT. A short shafting mounted on two uprights, used extensively by American watchmakers. It is indispensable in using milling tools, wheel cutters, and pivot polishers.

top of the bench and are held firmly in place by means of nuts or thumb screws. The pattern shown in the illustration is mounted on a solid metal base which can be fastened to the bench by means of screws. The advantages of using a countershaft are three fold; first, you are able to regulate your speed perfectly; second, your belt is carried to the back of the bench, where it is out of the way, instead of coming down in front of the head; third, you obviate the necessity of having holes in your bench on each side of the lathe, that small articles may drop through.

COUNTRSINK. To enlarge the outer end of a hole for the reception of the head of a screw, bolt, etc. A tool used to turn out or



Fig. 100.

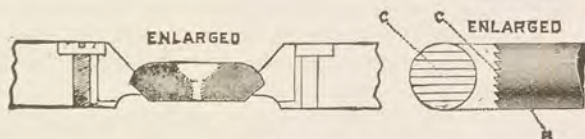

Fig. 101.

countersink. Figs. 100 and 101 illustrate Happersberger's patent flat-bottomed countersinks, which are designed for making or deepening flat-bottomed countersinks for screw heads of any kind. The screw-thread or hole will not be injured in using these tools. Fig.

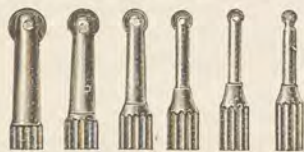

Fig. 102.

102 illustrates a set of wheel countersinks made with cutters on one end and burnishers on the other. Countersinks are also made from steel in the form of drills and from emery in the form of a cone, with metal handle for revolving. The

emery countersink will be found very useful for large holes and for trimming the edges of holes in enamel dials.

CRANK. The bent portion of an axis serving as a handle or connection for communicating circular motion, as the crank on a steam engine. To twist or distort, as applied to metals.

CREMAILLERE. The rack which winds the spring of the repeating train.

CRESCENT. The concave formed in the roller of the lever escapement to allow the passage of the safety pin.

CROCUS. Sesquioxide of iron used with oil for polishing brass and steel work. Crystals of sulphate of iron are subjected to a great heat, and then graded into polishing powders of various degrees of fineness. The more calcined part is of a bluish purple color, coarser and harder than the less calcined and is known as crocus. The less calcined and finer portion is of a scarlet color and is known as rouge.

CROWN-WHEEL. A wheel whose teeth are set at right angles to its plane. A contrate wheel. The escape wheel of the verge escapement is a crown wheel.

CRUCIBLE. A melting pot capable of enduring great heat, without injury and used for melting metals. It is made of clay or clay compounded with black lead and other materials.

CRUTCH. The wire which connects the pallet staff of a clock to the pendulum and by which the pendulum is kept in motion. This wire enters a longitudinal slot in the pendulum rod, if the rod be made of wood, or is made in the form of a U if the rod be a metal one. The slot is usually lined with brass. A clock with long wooden pendulum is usually brought to beat by either moving the crutch on the pallet staff or by bending the crutch itself.

CRYSTAL. A term applied to the glass of a watch case. Crystals for watches were first used between the years 1615 and 1620.

CUMMING, ALEXANDER. A celebrated clockmaker of England, who was born about 1732 and died at Pentonville in 1814. He was the author of a book called "Elements of Clock and Watch Work," which he published in 1766. There stands in Buckingham Palace today a clock made by Cumming for George III., which registers the height of the barometer every day throughout the year. He was paid \$10,000 for this clock, and received \$1,000 per annum for looking after it.

CURB PINS. The two brass pins that stand on either side of the hairspring near its stud attachment, and are attached to the regulator. They effect the time of the vibration of the balance according as they are shifted by means of the regulator to or from the point of attachment of the spring. Some authors advise timing in positions by the curb pins. This should never be attempted. The regulator should always stand as near the center of the index as possible. The curb pins should never be far from the stud and should be just wide enough apart to let the spring move between them and no more. Instead of disturbing the curb pins when timing in positions, add to or take from the weight of the balance. See *Balance Screw Washers*.

CUSIN, CHARLES. A watch manufacturer of Autun, Burgundy, who in consequence of the great persecutions which protestants had to endure, went and settled in Geneva in 1587, where, it is claimed, he was the first to establish the watch trade.

CUSTER, JACOB D. The third maker of American watches, Jacob D. Custer, was born in Montgomery County, Pa., in 1809. In 1831 he went to Norristown, Pa., and began the manufacture of 'Grandfather' clocks. In 1840 he began the first of a series of twelve watches. The writer has in his possession one of these watches, which is numbered 5 and bears the date February 4, 1843. It is a three-quarter plate, lever escapement, and about 14 size. It has a fuzee evidently of English make, as is also the dial. The balance bridge is made of steel and is countersunk into the plate so that it is flush with the surface of the upper plate. The rest of the movement was undoubtedly made by Custer, including the case, which is of silver and of the old English type of boxed cases. The gilding is extremely thin. In 1842 Prof Bache, of the U. S. Coast Survey asked him to make an estimate on clocks to propel lights in the government light houses. His estimate was \$200, and he subsequently furnished several hundred of them. He had little or no educational advantages, and never learned a trade, and his sole knowledge of mechanics was acquired by associating with those who learned a mechanical trade and the knowledge gained by years of experience and experiment. He built several large clocks, one of which may still be seen in the Norristown Court House. He died in 1879.

CYCLOID. A curve generated by a point in the plane of a circle, when the circle is rolled along a straight line, keeping always in the same plane.

The path through which a pendulum travels, to secure uniformity in the time of its vibration, through arcs different in extent, should be cycloidal.

CYLINDER. The hollow arbor upon which the balance of a cylinder watch is mounted in such a way as to be free to vibrate thus allowing a tooth of the escape wheel to pass, and imparting motion to the balance

CYLINDER ESCAPEMENT. This escapement is one of what is known as frictional escapements, and the credit of the invention is given to George Graham. In the earliest watches to which it was applied the escape wheel was made of brass, but in this form it was unsatisfactory on account of the wearing caused by using a brass escape wheel. In later years a hardened steel wheel has replaced the brass one, and if well made answers very well for the cheap

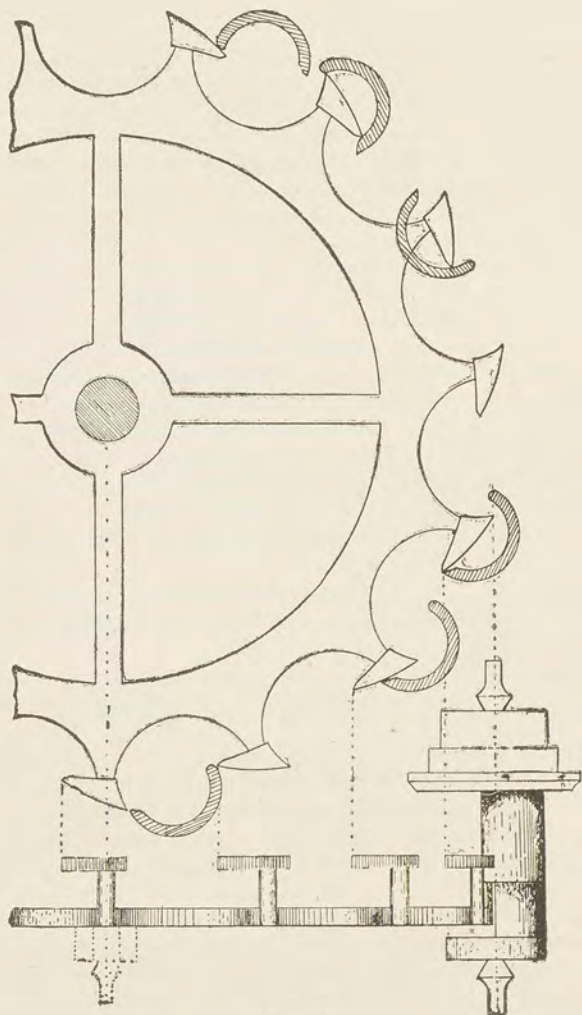

Fig. 103.

grade of watches, but for accurate timekeeping it cannot be compared to the lever and chronometer escapements. Fig. 103 shows the escape wheel and cylinder in both the plan and elevation, while in Fig. 104 is shown the cylinder considerably enlarged for the sake of clearness. The plugs are shown removed to the better illustrate the method of inserting them. At the height where the escape teeth strike, half the cylinder is cut away, while just below it is cut away considerably more, so as to allow the balance to vibrate almost a whole turn.

In the plan of Fig. 103 the cylinder and tooth is shown in the various stages of lifting. Immediately that the tooth has imparted the impulse it drops unto a portion of the cylinder, which is concentric to its axis. In Fig. 103 at the upper side of the escape wheel is shown a sectional view of the cylinder at the beginning of the impulse which will drive the balance around towards the right. In the second section the tooth has completed the impulse and dropped upon the interior locking surface, while in the following position it has continued around to the right until the completion of the vibration. The next action will be the returning of the cylinder to the position ready to receive the impulse which will cause the vibration in the opposite direction. This action of return is accomplished by the balance spring, which also at the same time unlocks the tooth, when the same action takes place in the opposite direction. The length of a tooth from the point which begins the impulse to that which ends it, measured in a straight line should be equal to the inside diameter of the cylinder, less the necessary amount for freedom, while the outside diameter of the cylinder should be equal to the space between the points of two teeth less the necessary amount for free action. From the above we see that there is a certain relation between the length of teeth and space between them, the inner and outer diameter of the cylinder and the thickness of the sides of the cylinder as well.

Examining the Escapement. In the examination of this escapement it must be remembered that it is as necessary that it be put in good condition and the same care be given to the work as in the better grades of watches. This point is of importance and seems to be the cause of much trouble which might otherwise be avoided, for it must be remembered that there is a certain limit in the care necessary to ensure a good performance, below which the work will be so poor that the watch will refuse to keep time. When first looking at



Fig. 104.

the watch the general appearance should be taken into account and also the motion of the balance. The balance should be true in the the round and flat, also in the balance spring the same condition should exist. The beat can be best tested by listening to the watch while running. If the cylinder is properly set relative to the balance the center of the impulse opening will be in a line with the small banking pin inserted in the rim of the balance and if in beat this banking pin should stand in a line with the balance center and the escape wheel center. The correction of the beat is made by shifting the balance spring around in the opposite direction to what the balance would have to be moved to correct it. The endshakes should not be excessive. Try the action of the teeth and the cylinder by slowly revolving the balance, noticing if the tooth drops upon the locking surface or upon the rounded impulse edge of the cylinder, which would most probably be indicated by a sluggish, jerky motion of the balance. Too shallow lock or no lock, may be caused by too shallow depthing or the cylinder running untrue, but in either case the remedy is obvious. The teeth should have the same amount of drop when they escape from either edge of the cylinder. The tops of the escape teeth must not touch the top of the cylinder when held in any position and it must be seen to that the arms which support the escape teeth do not strike on the cylinder either on the bottom or at the top of the passage cut out to free them. This last fault may be caused by there being too much endshake either in the balance or escape wheel or it being unequal between them. If the banking pin is properly placed and adjusted there will be no danger of overbanking. The pin in the balance cock, against which the banking pin strikes, should be bent in towards the balance center until the banking pin will strike it, but the balance will be free to vibrate. If the matching of the escapement is not correct it may be corrected by loosening the chariot screw and moving it in the direction indicated.

Making a New Cylinder. The first requisite in making a new cylinder is to get the measurements, such as the inner and outer diameter, total length and height of openings. The outer diameter is equal to the distance between the heel and the point of a tooth, allowing a sufficient amount for freedom of action. When turning out the cylinder in the rough it must be remembered that it will be necessary to allow enough metal to make up for that which will be removed in the finishing process. The inner diameter when finished is equal to the length of a tooth, plus clearance. The total length is found by removing the cap jewels and measuring from outside to outside of the hole jewels with a douzieme or other gauge. The cylinder proper must be enough shorter than the total length to allow for the length of the pivots. Heights of the openings may be measured by such a gauge as is used when replacing a cylinder or in the

absence of a gauge a piece of brass may be used, filing notches into it at the necessary heights. Having the several measurements, the next step will be to select a piece of superior quality of steel wire and anneal it thoroughly. A wire chuck is now selected which fits the wire when it is mounted in the lathe preparatory to drilling the hole, which should be first carefully centered, then drilled with a cylindrical drill, which will leave the hole true and smooth. The drilled hole should be somewhat smaller than the length of a tooth to allow for the final smoothing and polishing. After the hole is drilled, and without removing it from the lathe the body of the cylinder is to be turned down until it will almost go between the points of two teeth which must be reduced in the finishing until it will freely enter between the teeth. After the outside is smoothed by using oilstone powder on a bell metal slip, the cylinder may be cut off to length and the inside smoothed by using the oilstone on a piece of wire, but if a well made cylindrical drill was used, there will be but little need of this operation until the final smoothing and polishing.

The cylinder is now to be placed upon a piece of brass wire, fitting it closely and cemented to prevent it from turning around when cutting the passage. If the workman has a milling attachment for his lathe, this may be easily done by using a cutter of the right size, but if no attachment is at hand, it will be necessary to use small files afterwards smoothing by using oilstone powder and oil on bell metal or soft iron slips. After rounding the lips it may be hardened, being careful that the steel is not burned. If only one cylinder is to be hardened at a time, which will most usually be the case, an easy fitting piece of wire may be inserted which will equalize the heating and to some extent prevent burning of the steel. Oil should be used instead of water for the hardening, which will make the steel somewhat tougher. The portion of the cylinder which is subjected to the action of the teeth should be left full hard while the other portions are to be drawn to a blue. This drawing of the temper may be best done by fitting two pieces of wire which project from each end about half or three-quarters of an inch, but do not pass entirely through the cylinder and by holding the portion to be left hard in a pair of pliers the other parts may be tempered. The final smoothing and polishing may now be done, especial attention being paid to finishing the acting portions.

When drawing the temper of the cylinder, care is necessary to prevent the impulse portion from being softened, which would cause it to wear readily. The difficulty of readily seeing if all the parts are free of each other, makes it necessary that rather more care be exercised than when examining the lever escapement. There seems to be an inclination among some workmen to slight the cylinder watch when repairing it. The old saying that "what is worth doing

at all is worth doing well," should always be kept in mind by the workman, for no machine, much less a watch, will perform satisfactorily unless given due care.

An escape wheel when damaged is best replaced with a new one if a suitable one is at hand, otherwise one or more teeth can be replaced if carefully done, so as to give as good results as if a new wheel was used. To do this, first with a thin iron slip and oilstone powder make a thin groove in that portion of the web from which the tooth is broken, parallel with the flat of the wheel, and about half the thickness of the web in depth. Then take from an old wheel a tooth corresponding in size and shape to those of the wheel to be repaired, cutting through the web so that the pillar and that portion of the web extending back from the tooth are still attached.

Now with the oilstone slip, carefully shape the section of the web left attached to the tooth so that it will fit in the groove cut in the wheel, and at the same time make it as thin as possible without too much impairing its strength.

The portion that fits in the groove is now to be "tinned," that is, covered with a thin coat of soft solder, which is best done by melting the solder on the end of a flattened piece of brass or copper wire and applying while hot, having, of course, put a little soldering fluid (chloride of zinc) where the solder is to flow. Only enough solder should be used to cover that part that is in contact with the wheel. A little soldering fluid is now put in the groove and the tooth placed in position, being very careful that the point and heel of the new tooth are on precisely the same circle with the other teeth, and that there is the same distance between its point and the heel of the next succeeding tooth as exists between all the teeth of the wheel.

Fitting New Cylinder and Plugs. In most cases of broken cylinders the upper half is left while the lower and most important part is missing. Take total length over all first, the same as in replacing staff, which can be done by the use of the Staff Length Gauge, and then measure the length of the old cylinder from the under side of the hub to the end of the top pivot, and the difference between the two measurements will give the length of the lower part of cylinder and pivot, and this will serve as a guide in selecting an unfinished cylinder of proper length. The cylinders and also cylinder plugs can be purchased from material houses. Having selected a cylinder, proceed to center it in the lathe in a finely centered chuck, leaving lower end exposed. Turn the lower pivot first; then finish off the lower plug, and if necessary, turn off any surplus body of shell from the lower part of the cylinder as occasion demands. For obtaining the requisite

measurements for the work, the little tool shown in Fig. 19 and the Staff or Cylinder Height Gauge shown under *Gauges* will be found useful. Saunier advocates the use of experimental cylinders, and suggests that the workman will do well to make two or three different sizes during his leisure moments. They can be made from the cylinders kept in stock by material dealers. The cylinder and lower plug are better to be in one piece to increase the strength; the slot shallow and in different positions, (for the position of the banking slot is the most difficult to ascertain), and the cylinder only perforated where the top plug is inserted. The top plug should be removed, the hole tapped, and a new plug, somewhat longer, screwed in. The action of this tool is similar to the Staff Height Gauge mentioned above.

After the lower end is finished the wax is turned away and the cylinder turned true and finally cut off at the proper length, preserving as fine a center as possible, after which the cylinder is reversed and finished.

In pivoting, it is very seldom necessary to drill the cylinder, as the upper and lower pivots are generally the extremity of plugs closely fitting in each end. In most cases the top pivot may be replaced by resting the cylinder on a stake, the hold of which is of a sufficient diameter to allow of the entrance of the plug, and too small to allow the cylinder to pass through. A knee punch and a few light taps of a hammer are generally sufficient to drive the plug out far enough to admit of the turning of a new pivot. The lower plug must be driven out entirely (being too short to admit of turning a new pivot) and a new plug inserted. The plugs must be made to fit tightly without taper, as with a taper plug there is great danger of splitting the cylinder. Should the plug be very tight and difficulty is encountered in driving it out, a few light taps all around the cylinder will generally stretch it enough to remove the plug easily.

CYLINDER HEIGHT TOOL. See *Gauge*.

CYLINDER PLUGS. Steel plugs fitted to the ends of a cylinder and on the ends of which the pivots are formed. Cylinder plugs can be obtained ready made from material dealers; assorted sizes in neat boxes.

DAMASKEEN. To decorate a metal by the inlaying of other metals, or by etching designs upon its surface. The embellishment of the surface of metals with rings or bars is snailing and is not damaskeening, although improperly called so by watchmakers and watch factory employees particularly. See *Snailing, also Electro Plating, Bronzing and Staining*.

DAY. The whole time or period of one revolution of the earth on its axis.

Solar Day. The period during which the sun is above the horizon or shines continuously on any given portion of the earth's surface. Also called astronomical day, since the length of this day is continually varying, owing to the eccentricity of the earth's orbit and the obliquity of the ecliptic, a mean solar day is employed which is the average period of one revolution of the earth on its axis, relative to the sun considered as fixed. In astronomy and navigation the day is reckoned from noon to noon, but the civil day is reckoned from midnight to midnight. The mean solar day is uniformly equal to twenty-four hours.

Sidereal Day. The interval between two successive transits of a given star. It is uniformly equal to 23 hours, 56 minutes, 4.099 seconds, or 3 minutes, 55.901 seconds less than the mean solar day.

DEAD BEAT ESCAPEMENT. An escapement in which, except during the actual impulsion, the escape wheel remains stationary and does not recoil. See *Graham Escapement*.

DECANT. To pour off a liquid from its sediment; as the decanting of diamond powder, prepared chalk, etc. Saunier advises the watchmaker to prepare all his smoothing and polishing materials by decantation, as he will by this means free them from hard or large particles and obtain a uniform grain. At the present time the watchmaker can, however, obtain diamond dust, prepared chalk, etc., ready for use, that are supposed to have been properly decanted. There are, however, many poor concoctions that have not gone through the proper treatment, and if the watchmaker is desirous of doing fine work and having reliable materials always at hand, it is well to decant these preparations, even though they be labeled "prepared." The operation is a very simple one and takes but little time. The material, being reduced to a powder, is placed in a vessel filled with water, oil, or other liquids, according to the nature of the material to be operated upon, and after being thoroughly stirred it is allowed to partially settle. The liquid is then poured into another vessel, the heavy portion remaining in the bottom of the first vessel. This residue is only fit for use in the very coarsest work. The liquid is then stirred, allowed to settle partially again and is then poured into another vessel. The powder left should be labeled 1. By successive operations, each time increasing the interval of time allowed for settlement, finer deposits can be obtained, which may be labeled respectively, 2, 3, 4, etc. In decanting diamond powder or oil-stone dust, oil should be used; for tripoli, rottenstone, or chalk, water; and for hartshorn and some other materials, alcohol is used. Diamond powder, as purchased from the material dealer, can rarely be improved upon by manipulation unless the operator is expert.

DEMAGNETIZER. A machine or tool used to remove magnetism from parts of watches. There are several demagnetizers upon the market. In some of these machines the arc and incandescent electric light wires are attached to generate the magnetism, while in the Ide demagnetizer it is generated by the use of horseshoe magnets.

The Greaves demagnetizer, shown in Fig. 105, is intended to be used either with a battery or electric light wire.

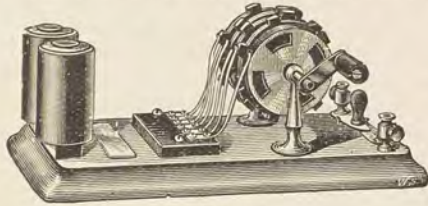

Fig. 105.

Fig. 106 shows the Berlin Demagnetizer; it is constructed on a principle similar to the Greaves, and like it, gives the best results when used with electric light wires. Procure an attachment plug and fasten to the end of the flexible cord accompanying machine. Insert a lamp receptacle and turn on the current.

Press down the key and turn the handle of commutator, about 150 revolutions a minute. Insert the watch or part to be demagnetized into the opening of the magnet, and revolve very slowly, keeping it in a straight line with the center of the magnet until at a distance of two

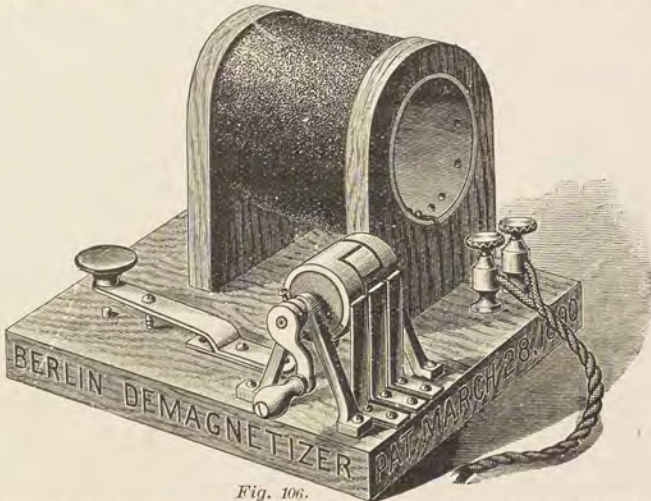

Fig. 106.

or three feet. Keep turning commutator at regular speed. Release key before ceasing to turn. It is not necessary to remove the movement from the case nor to let it remain in the magnet. While the current is on and the handle being turned with key down, insert the watch into the opening and proceed as above.

DENISON, E. B. A barrister of London, who was requested by the government to draw up, in conjunction with the Astronomer-Royal, specifications for the construction of a large clock for the Victoria Tower of the Houses of Parliament. Vulliamy and other leading clockmakers, who were invited to tender for the work, all demurred to a stipulation that the clock should be guaranteed to perform within a margin of a minute a week, which they declared to be too small. Mr. Denison would not yield, and the clock makers were equally firm. Eventually it was decided to entrust the work to Mr. Dent, who was to make a clock from designs to be furnished by Mr. Denison. Mr. Denison's temerity was justified by his success. The Westminster clock, says Britten, turned out to be the finest timekeeper of any public clock in the world. The double three-legged gravity Escapement was invented for it, besides a new maintaining power and a novel arrangement for letting off the hours to satisfy another of the conditions, which required the first blow of the hour to be given within a second of the true time. Mr. Denison was elected President of the British Horological Institute in 1868, and succeeded his father as baronet, taking the title of Sir Edmund Beckett in 1874. In 1886 he was called to the House of Lords under the title of Baron Grimthorpe.

DENNISON, AARON L. The father of the American watch factories. The first person to apply the interchangeable system to the manufacture of watches. This he did in 1850. He was the son of a shoemaker of Freeport, Me., and was born in the year 1812. He was apprenticed to James Carey, a watchmaker of Brunswick, Me., in 1830. In 1839 he was engaged in a general watch and jewelry business in Boston and also carried a line of watchmakers' tools and materials. Invented the Dennison Standard Gauge in 1840. In the fall of 1849 he began to build machinery for the manufacture of watches on the interchangeable system, having associated himself with Messrs Howard, Davis and Curtis. In 1850 he completed the model for the first watch which was 18 size, with two barrels, and was made to run eight days. The watch, however, was not a success, and its place was filled by a one day. At this time



Aaron L. Dennison.

the company was known as the American Horologe Company. In 1851 the name was changed to the Warren Manufacturing Company, and the first one hundred watches bore that name. The first watches were placed on the market in 1853. The next six hundred watches bore the name Samuel Curtis and the name of the company was then changed to the Boston Watch Company. In 1854 the factory was removed from Boston to Waltham, the company then making about five watches per

day, and employing ninety hands. After the removal the movements were engraved Dennison, Howard and Davis. In 1857 the company assigned, and the property was purchased by Mr. Royal E. Robbins for \$56,000. Mr. Dennison was then employed as superintendent and filled that position until 1862. In 1864 he, with others, organized the Tremont Watch Company. He retired from this company in 1866, the name of the company having in the meantime been changed to the Melrose Watch Company, and the factory removed from Boston to Melrose, Mass. Prior to the removal, the barrel, plates and minor parts were made in the Boston factory, while the trains, escapements and balances were made in Zurich, Switzerland, Mr. Dennison having charge of the latter factory. In 1868 this company failed and Mr. Dennison was deputized to sell the factory, which he did, to the English Watch Company, of Coventry, Eng. Mr. Dennison then went to Birmingham, Eng., and embarked in the manufacture of watch cases. In this he was quite successful, the firm being known as Dennison, Wigley & Co. He died at his home in Birmingham on Jan. 9, 1895.

DENT, E. J. Born in 1790 and died in 1853. Builder of the great Westminster Clock, London.

DEPTH. The contact point between a wheel and pinion.

DEPTHING TOOL. A mechanical device for transferring the depthing of a wheel and pinion to a plate, and also for testing the depthing to see if it is correct. The value of a depthing tool depends altogether upon its accuracy, which may be tested by the following method. The joint should be well fitted and move with a light friction. The jaws which carry the centers should open parallel to each other to the full extent of their motion, and the seat for the centers must be parallel with the motion of the jaws and each other as well. The accuracy of the centers may be best tested by means of a micrometer caliper by measuring the centers at various distances apart, and also



Fig. 108.

at the opposite ends of the centers. In any position the measurements should be exactly alike. In the absence of the micrometer caliper the accuracy may be tested by drawing a circle with each set of centers, and with a strong eye-glass examine them and see if they coincide with each other. The variation, if any, will be more marked if the centers are first pushed back as far as possible and then drawing them out to their full extent. When using the tool the centers should be opened by means of the screw sufficiently to clear the work to be inserted, then after the work is in, the tool is

carefully adjusted until the depthing is correct. When the correct distance is found the work is to be removed and the centers so set that when the depthing is transferred to the plate they will be at right angles with the plate. If this is not done the depthing will be too shallow in the plate.

DERHAM, WILLIAM. An eminent English divine, and one of the early writers on practical horology. He was born at Stourton, near Worcester, in 1657, and died in 1735. He was the author of "The Artificial Clockmaker," a treatise on watch and clock work, showing the art of calculating numbers for all sorts of movements; the way to alter clock work, to make chimes and set them to musical notes, and to calculate and correct the motions of pendulums. It was published about 1700. He was also the author of a work, entitled, "Philosophical Experiments and Observations of Dr. Robert Hooke, F. R. S." and another, called "The Antiquity of Clock-work."

DETACHED ESCAPEMENT. The escapement of a time piece in which the balance, or pendulum, is detached from the train, during a portion of its vibration.

DETENT. That which locks or unlocks a movement; the piece of steel that carries the stones that lock and unlock an escape wheel.

DE VICK, HENRY. A celebrated German watchmaker of the fourteenth century and the builder of the famous clock belonging to Charles V., of France. Also claimed, by some writers, to be the inventor of the Verge escapement. See *Clocks*.

DIAL. The graduated face of a time piece. Dials were first enameled by Paul Viet, of Blois, in 1635.

The greater majority of American dials are what are known as enamel dials, which consist of a copper plate for a base and an enameled face. The process of making these dials, as carried on in our factories, is as follows: The copper is shaped and holes punched in one operation. The feet are then brazed on, after which the enamel is applied to both the back and face, after which it is fired. After smoothing they are again fired, and, if perfect, they are sent to the painter. For many years after most of the other work in our factories was done by machinery; the painting of dials was hand work. The Waltham Company, after experimenting for a number of years, finally brought to perfection a process, by means of which the dials are lettered, and the numerals, minute and second marks are printed by photography. Various processes are used in other factories, among them being the transfer process, which is effected

by rubbing the enamel paint into a steel plate into which the lettering of the dial is countersunk, taking an impression from this plate upon a rubber platen and then transferring this impression to the dial. After painting, the dials are again fired.

Dials of gold, silver and other metals are extensively used, particularly in the Spanish-American countries.

To Drill an Enamel Dial. Select a piece of soft copper wire of the diameter you wish the hole, file off the end perfectly flat and hammer into the copper a small quantity of fine diamond powder. This form of drill will be found to perforate the enamel of a dial quite rapidly. Broaches made in the same manner give excellent results. These tools can be used either by revolving in the fingers or in the lathe. Emery countersinks will be found very useful for trimming the edges of holes in enamel dials.

To Remove a Name From Dial. Apply a little fine diamantine to the end of your forefinger, and gently rub the name until it disappears. The finish can be restored by polishing the place carefully with a small quantity of diamantine mixed with oil, and applied by means of a small piece of cork. An agate burnisher is also used for the same purpose.

To Remove Stains From Enamel Dials. Enamel dials sometimes have black or cloudy stains upon their faces, caused usually by the tin boxes in which they are shipped. These can be removed with a piece of soft tissue paper previously dampened with nitric acid. Wipe the stained places, carefully avoiding the painted portions as much as possible, for in some very cheap dials the painting is not well fired, and may be injured by the acid. Wash the dial thoroughly in clean water and dry in sawdust.

To Reduce the Diameter of a Dial. Rest the dial in an inclined position and file the edge with a half smooth file, dipping the file in turpentine occasionally, and finish with a fine emery stick.

To Repair a Chipped Dial. Gently heat the surface of the dial and fill the hole with a compound of white lead and white resin, heated over the flame of a spirit lamp. It is better to heat the blade of a knife rather than the wax, and run no risk of discoloring the wax. Cut off a small piece of the wax and press firmly into the hole, allowing it to project a little above the dial. When cold, scrape down even with the dial, and finish, by holding it close to the flame, when the patch will gloss over nicely. Be careful and do not get it too close to the flame, or you may turn the enamel yellow. A mixture of white lead and white wax applied and polished by friction is also used, but it is not as handy and is not as capable of a high polish.

To Clean Metal Dials. Silver and gold dials can be restored by gently heating the back over a spirit lamp and dipping the dial in diluted nitric acid. If the figures are painted however, they will be removed, and it will be necessary to repaint them, but if they are enameled on, the enamel will not be injured. If the figures are painted the dial may be cleaned by brushing with powdered cream of tartar either dry or in the form of a paste mixed with water. Avoid all the painted portions and work the paste in between the painted portions with a pointed peg wood. Wash with warm water and dry by carefully patting with a soft linen rag.

To Grind Enamel from the Back of Dial. It is sometimes necessary to remove a portion of the enamel from the back of a dial to allow room for the motion work, etc. The most convenient method is to grind the back with emery, preferably in the shape of a wheel. Water should be applied to the work from time to time to prevent heating.

Luminous or Phosphorescent Dial. A dial covered with varnish or a solution of white wax in turpentine, over which is dusted powdered sulphide of barium. Such a dial is luminous in the dark so that it can be read without a light. It loses its phosphorescence after a time, but this may be restored by exposing it to sunlight or to the flame of magnesium wire.

DIALING. The art of constructing dials. The science which explains the principles of measuring time by the sun dial.

DIAL WORK. The motion work of a watch between the dial and the movement plate.

DIAMANTINE. This polishing agent is used extensively for polishing steel, and is a preparation of crystallized boron. It is not applicable to brass or copper work. Rubine and Sapphirine are similar chemical preparations; they act quicker, but do not yield as good results.

DIAMOND DRILLS. Pieces of copper wire, in the ends of which are embedded fragments of diamond in the shape of triangular prisms and held in place with shellac. They are used for drilling jewels, etc. They may be obtained from material dealers.

DIAMOND GRAVERS. These are very similar to diamond drills and are mounted in the same manner, but usually consist of larger, though shorter and stronger diamond fragments, and are used for shaping jewels, etc. They may also be obtained from material dealers.

DIAMOND LAPS OR MILLS. These are of two kinds, one for grinding and the other for polishing. The grinding mills are copper discs, from an inch to an inch and a half in diameter, into the surface of which diamond powder of various grades has been hammered or rolled. The polishing mills are made of box-wood, vegetable ivory, etc., and the powder is applied to their surfaces in the shape of a paste mixed with olive oil. These mills are useful for cutting or polishing ruby-pallets, and other hard stones, for flattening stones to be used as jewels and for manipulating hard steel.

DIAMOND FILES. Strips of copper into the face of which diamond powder of various degrees of coarseness has been hammered or rolled. Used for working ruby-pallets and other hard stones and hard steel.

DIAMOND POWDER. A cutting and polishing agent prepared from the crushed chips from the diamond cutter's table, black, brown, and other inferior stones, known as bort, and small diamonds. After pulverizing thoroughly, the powder is decanted in olive oil to various degrees of fineness. To be had of material dealers generally. Used for charging the face of mills or laps for grinding and polishing hard stones, etc. It is also used for drilling by being applied to the end of a small taper piece of steel, flattened on the end for the reception of the powder, which is moistened with olive oil.

DIPLEIDOSCOPE. An instrument invented by J. M. Bloxam, in 1843, used for determining the time of apparent noon. It consists of two mirrors and a plane glass disposed in the form of a prism, so that, by the reflection of the sun's rays from their surfaces, two images are presented to the eye, moving in opposite directions, and coinciding the instant the sun's center is on the meridian.

DIVIDING PLATE. See *Index*.

DOG. A clutch. An adjustable stop to change the motion of a machine tool.

DOG SCREWS. The screws with half heads by which a movement is held in its case.

DOUBLE ROLLER ESCAPEMENT. A form of the lever escapement in which a separate roller is employed for the guard action.

DOUBLE SUNK DIAL. A dial having two sinks, one for the hour and another for the seconds hand.

DOUZIEME. A unit of measurement indicating, $\frac{1}{12}$ of a line or $\frac{1}{144}$ of an inch. See *Gauge*.

DRAW. The angle of the locking faces of the pallets, as in the lever escapement.

DRAW PLATE. A plate of very hard steel for drawing wire of various shapes and diameters. They are made for drawing round, half-round and square wire. The plates are sometimes formed of jewels for working steel wire, etc. These plates are very handy for readily reducing wire to any desired diameter, and may also be employed for reducing the diameter of bushings.

DRIFTING TOOL. A tool for punching holes in mainsprings, etc. It consists of a frame to be held in the vise, through which a screw passes, and to the end of which a handle is attached. It is used but little in this country, as the mainspring punch has superceded it, being simpler and quicker to operate.

DRILLS AND DRILLING. Drilling may be effected in two ways, by rotating the drill and holding the work stationary, or *vice versa*. The most satisfactory results, however, are obtained by revolving the work and gradually bringing the drill into contact with it. Although it is not always possible to do this, owing to the shape of the article to be drilled. A drill of the shape shown in Fig. 109 is preferable for drilling hard



Fig. 109. Fig. 110. Fig. 111. Fig. 112.

steel, while the shape shown in Fig. 110 is best suited for drilling soft steel, brass, etc. Oil or glycerine diluted with alcohol is the best lubricant for the softer metals, but when drilling hard steel turpentine should be used. Drills of the form shown in Fig. 111, are used for drilling flat bottomed holes, for countersinking screw heads, etc. See also *Countersinks*. The twist drill shown in Fig. 112 is desirable when drilling deeply, as this form of drill heats slowly and the particles are carried to the surface of the work. Pivot drills, like those shown in Fig. 113, can be purchased from material dealers, mounted on cards and ready for use, at such small cost that it will scarcely pay the watchmaker to make them.

Drills of a form indicated by Fig. 114 are recommended highly by Saunier and are known as semi-cylindrical drills. They are made from cylindrical steel rods, rounded at their ends and filed down to a trifle less than half their thickness. The length of the point should be greater

or less according to the nature of the metal to be operated upon, but under no circumstances must the point itself be sharp. This form of



drill should be sharpened on the round side and not on the flat surface. It possesses, says Saunier, the advantages that when placed in a drill-chuck it can be turned exactly round, of the required diameter and finish; so that whenever replaced in the chuck, one can be certain beforehand

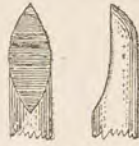

that the hole drilled will be of a definite diameter. With such a drill the hole is smoothed immediately after it is made by one or the other cutting edges.

DRILL REST. In using the lathe for drilling, a great saving in both time and drills can be effected by using a drill rest similar to that shown in Fig. 115. It is well to have a half dozen different sizes, starting at $\frac{1}{4}$ inch and increasing by $\frac{1}{8}$ inch, for various classes of work. These rests are not kept by material dealers, but can be made by the watchmaker. Saw from a piece of rolled sheet brass, say 1-16 inch thick, the circles required, leaving metal enough to finish nicely

Place a steel taper plug in the taper chuck of your lathe and turn down a recess, leaving a shoulder on the taper. Drill a hole through the brass plate to fit the steel taper tightly. Place the end of the taper on a lead block

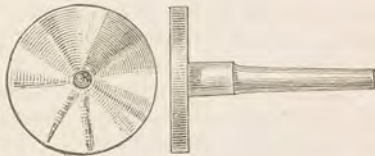

Fig. 115.

and proceed to rivet the brass plate on the taper, making sure that it is true. Replace the taper in the lathe-chuck and proceed to turn the face and edge of the brass plate perfectly true and to the proper size. Those who have tried to drill a straight hole through an object by holding it in the fingers know just how difficult it is to do, but by placing one of these drill rests in the spindle of the tail stock, placing the article to be drilled against it and bringing it up against the drill, you can drill the hole perfectly upright and avoid all danger of breaking the drill.

DRILL STOCK. A tool used for holding drills, the more modern variety having a small chuck on one end for centering and holding the drill.

DRILLING LATHE. A lathe, used for centering and drilling staffs and pinions. The plate has various sizes of conical holes for supporting the arbor, and can be turned upon its center.

DROP. Is the amount of freedom allowed, in parts which come in contact with each other, to compensate for inaccuracies in workmanship. In horology it is principally applied to the escapement action where a tooth of the escape wheel drops a varying distance from the completion of one action to the beginning of another. In the chronometer, and other escapements, there are two drops. One drop begins at the completion of the unlocking, when the tooth falls upon the impulse pallet, and the other one begins at the completion of the impulse and ends when the tooth drops upon the locking stone. In the lever and cylinder escapements the drop is known as inside or outside drop, according as it takes place on the inside or outside of the pallet or cylinder. All drop is just so much power wasted and should be as small as possible.

DRUM. The barrel of a turret clock on which the driving cord is wound. There is a variety of escapement, known as the Drum Escapement, which is met with but little in this country. Britten says this variety of escapement is a continual source of trouble to English repairers. It receives impulse from every other vibration only, and the idea of the escapement appears to be, that by providing a long frictional rest on one of the pallets, the extra pressure of the escape wheel tooth, when the mainspring is fully wound, will be sufficient to prevent any considerable increase in the arc of vibration of the pendulum. Clocks with this escapement, however, often stop from the diminished power when the spring is nearly run down, again, when it is fully wound, because the small and light pendulum has not the energy to unlock the pallet.

DUPLEX ESCAPEMENT. This escapement is shown in a plan view in Fig. 116, while Fig. 117 shows an elevation of the staff and one tooth of the escape wheel. This escapement was no doubt so named on account of the double escape wheel, which was used in the earliest forms. Duplex is a Latin word meaning double, and there is but little doubt that this escapement derived its name from the fact of this double escape wheel, although some writers claim it was the invention of a watchmaker by the name of Dupleix, an Englishman, who was even but little known in his own country, and from whom the name was derived. Saunier says of this invention: "The first crude suggestion of the duplex escapement seems to have been made by Duterte, a clever French watchmaker; but Pierre Le Roy was the real originator of this mechanism, having first constructed it about the middle of the last century." Some very good results were obtained from it, but on account of its susceptibility to wear at the pivots, as well as for other reasons, it has fallen into disuse, until it was modified and adopted by the Waterbury Watch Company, where it has proven very satisfactory. The impulse teeth rise from the

plane of the body of the wheel and are represented in the black outlines of Fig. 116, while the long teeth are the locking ones. The center of the escape wheel and balance are planted close enough so that

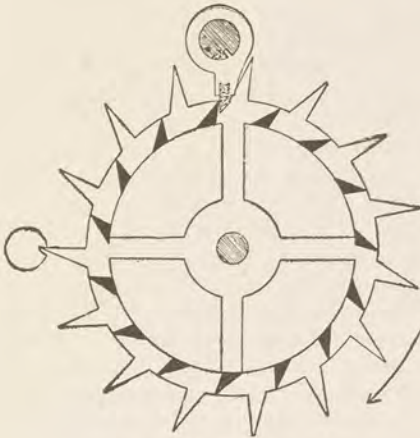

Fig. 116.

the circle of the escape wheel and the duplex roller intersect each other sufficiently that the escape teeth cannot pass except when the tooth drops into the notch of the roller and is traveling in the same direction of the escape wheel. At the instant that the tooth passes the notch the impulse tooth strikes upon the impulse pallet, thus imparting the power to the balance. In the return vibration the locking tooth falls into the notch, but the momentum of the balance overcomes that of the escape wheel, and no impulse is transmitted until both balance and escape wheel are moving in the same direction. The locking of the escape wheel in this form does not take place under favorable conditions, for when the balance is returning just prior to the receiving of an impulse the friction is engaging and when in this position, any slight roughness on the roller would cause a wedging action, causing the watch to stop. By reference to the figure it will be seen that the balance is at no time detached from the motive power, being more or less influenced by it during its entire vibration. In some of the older and finer specimens of the duplex the roller was made of ruby, but as now made it is always of steel. It will be noticed that

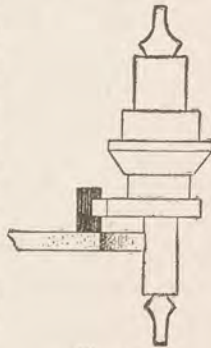

Fig. 117.

at the time a tooth is unlocked the action is very much like the chronometer, and at the locking resembles the cylinder to a certain extent. The drop is changed by shifting the impulse pallet on the balance staff. If the drop is too great the impulse pallet is to be moved so that the angle between the roller notch and the impulse pallet is greater and if the drop is not sufficient they are to be moved closer together. When in beat the notch in the roller should point to the center of the escape wheel, although this point is varied by different workmen. Some authors say that this escapement requires considerable drop, sometimes as much as ten degrees. In this, as in the chronometer, the amount of drop should be the smallest amount possible to have a positive action of the impulse. All drop is just so much power wasted and the less we can have it the weaker mainspring we can have and in this respect is so much less power upon the train which could only cause it to wear away at the various points of contact. The balance jewels should fit the pivots accurately, as if they do not the tooth may catch or bottom in the notch of the roller when held in certain positions, and in others the tooth would not have sufficient hold on the roller for the safety of the locking. When cleaning it is necessary that the roller notch be thoroughly cleaned.

A balance spring having about ten coils is the best suited to this escapement. The watch previously referred to, which is made in this country, has proven that the duplex escapement, when well made, compares very favorably with the same grades of lever watches, and superior to the cylinder in point of timekeeping. The setting of the escapement, which in the older forms of the escapement has been well-nigh eliminated, there being no more difficulty experienced with this than any other watch. The workman who uses the same care when repairing one of these watches as he would in a lever, will have but little trouble in getting a satisfactory performance. Among the more prominent causes of stoppage in the escapement are, a roller which is not true, and this will most probably be found in one where some workman has tried to pivot the staff and failed to get it properly centered, the teeth catching in the notch and a roller poorly smoothed, a point of a tooth may be slightly bent so that it cannot enter the notch or bind.

DUPLEX ROLLER. The ruby roller of the duplex escapement.

DUST BANDS. Thin metal bands or guards which are inserted between the upper and lower plates of a movement to exclude all dust.

EARNSHAW, THOMAS. A celebrated watchmaker of London, who was born at Ashton-under-Lyne, Lancashire, in 1749, and died in 1814. He was the inventor of the spring detent escapement and the

compensation balance, both substantially as now used in chronometers. He made his improvement in the spring detent in 1781. He presented a petition to the Board of Longitude for aid in 1791, and again in 1797. He received his long-contested reward, Dec. 27, 1805.

EAST, EDWARD. A celebrated watch and clockmaker of London. He was one of the ten original assistants appointed by the Charter of Incorporation of the Clockmakers' Company in 1632. Was Warder in 1638-9, Master in 1645-52, Treasurer in 1637, being the only occupant of the latter office in the history of the company. He was watchmaker to Charles I.



Thomas Earnshaw.

ELECTROPLATING, BRONZING AND STAINING. The first requisite in attempting to do electroplating in a small way is to understand the battery and to select one that will give an electric current of the proper intensity and quantity for the required time, without too much care and attention on the part of the workman. Were he provided with measuring instruments, so that he could readily determine when his current was changing in quantity and power, the choice of a battery would not be of so much importance; but volt meters and ampere meters are too expensive to be possessed by the average man who does plating in a small way, and he is necessarily obliged to depend on theory in arranging his forces and judge of the results by the appearance of his work in the bath. Hence it is important that he should have an understanding of the nature of the action in the battery and be able to maintain the requisite conditions from the appearance of the battery itself.

Without attempting to give too close a definition, electricity may be defined as a force or energy which is the result of a displacement of the normal balance of forces between two elements in close connection with one another. This normal force is called the potential of its element, and if two elements having different potentials, are connected together and placed in a fluid which will produce chemical action upon one or both, the result will be a flowing of energy through the connection to the element having the lowest potential. This will be kept up as long as the chemical action continues and the connection between the two elements remains unbroken. It will be readily seen that, owing to the varying potentials of the different elements, the varying facility of the conductors used to connect them, and the varying intensity of chemical action in the solution employed, the electrical current will vary in strength (or voltage) in different batteries, and in quantity, according to the size of the elements and the freedom with which they are attacked by the solution.

Voltage is the measure of strength or intensity of the current and depends upon the difference of potentials of the elements and the kind of chemical action between them. It is the same for the same combination, regardless of the size of the elements. Thus, a battery the size of a thimble has the same voltage as one the size of a door, if the elements and solution are the same. We have not the space to explain this at length, but will simply state that the volt is the recognized unit of the measurement of strength of electric currents.

The ampere is the unit of measurement of the quantity of currents. Amperage depends on the size of the elements; and the available amperage depends on the size of the conductors and the freedom of action between the elements. Amperage is consumed by doing work or by the heating of insufficient conductors, or by undue resistance in the battery, just as power is consumed in turning steel, or in running shafting, or overcoming the resistance caused by friction of boxes on a shaft that is run without oil. Strictly speaking, if the voltage or intensity of the current be sufficient to do the work required, then the amperage is the force used to do the work, and it is destroyed by that work and the chemical or electrical resistance, just as mechanical power is consumed in running a lathe or doing any other work. From this, it follows, that in order to operate economically, extreme care should be taken that the connections be large enough to carry the current easily; that the solution be kept in perfect order, both in the battery and the plating vat; and that all joints be kept bright and firm so as to insure perfect contact and offer no resistance to the passage of the current.

The current always flows from the element having the highest potential (called the + or positive pole) along the wire and through the solution in the plating vat, to the other wire, and thence to the negative pole, carrying with it in passing through the solution, particles of metal from the anode and depositing it on the article to be electroplated (called the cathode); hence care should be taken to *always* get the cathode affixed to the *negative* (—) pole of the battery, in order that it may receive the deposit.

Electrical resistance is that property of conductors (wires, solutions, objects, etc.) by which they tend to reduce the intensity of a current passing through them. The practical unit of resistance is the ohm. The number of amperes of current flowing through a circuit is equal to the number of volts of electro motive force, divided by the number of ohms of resistance in the entire circuit, that is from positive pole clear through wires, solution and battery, back to the starting point. Thus it will be seen that if the resistance be greater than the voltage of one cell will overcome, no current will flow, and the voltage must be increased to such an amount as will allow the desired quantity of current to pass. This is done by coupling cells in various ways, which will be explained at length further on.

The resistance of a conducting wire is directly proportional to its length, and inversely proportional to the square of its diameter; hence it follows that the short and large wires cause less loss of current than smaller and longer ones.

In all batteries the resistance increases with the distance between the elements, and decreases when the immersed surfaces are increased. The resistance is also increased by the bubbles of hydrogen liberated at the positive pole sticking to it in great numbers. Hydrogen is a nonconductor and prevents the action of the solution on the metal. When this takes place to such an extent as to stop chemical action altogether, no current will pass and the battery is said to be polarized.

These remarks are intended to aid in the intelligent selection of batteries, etc., those who, having to deal with such apparatus, yet have never had the opportunity to study an electrical treatise. We are often asked: What is the best battery? We can only answer: There is no best battery; that is, no battery is suited to all kinds of work. That which is best in one case may be worst in another. The suitability of a battery for any special purpose depends on what is called its constants, i. e., electro-motive force and internal resistance. In order to be really perfect a battery should fulfill the following conditions:

1. Its electro-motive force should be high and constant.
2. Its internal resistance should be small.
3. It should give a constant current and must therefore be free from polarization, and not liable to rapid exhaustion, requiring frequent renewal of material.
4. It should consume no material when the circuit is open.
5. It should be cheap and of durable materials.
6. It should be manageable and, if possible, should not emit corrosive fumes.

No single battery fulfills all these conditions, however, and, as we have already intimated, some batteries are better for one purpose and some for another. Thus, for telegraphing through a long line of wire, a considerable internal resistance is of no great consequence, as it is but a small fraction of the total resistance in circuit. For electric gas lighting or other low resistance circuits, on the other hand, much internal resistance would be, if not absolutely fatal, certainly a positive disadvantage. The most reliable batteries for electroplating work are the Daniel, Gravity, Bunsen, Smee and Carbon, which we will accordingly describe in their order.

The Daniell, Fig. 118, consists of a glass or stoneware jar, containing a cylinder of copper surrounding a porous clay cup, in which stands a cylinder of zinc. At the upper part of the copper sheet is a pocket of perforated copper, which is filled with crystals of sulphate of copper. The object of the pocket is simply to hold the sulphate up to the top of the solution, so that it will dissolve more readily, and any other method

would do as well. In charging this battery, *i.e.* glass vessel and the porous cup are filled with water, and crystals of sulphate of copper are put in the pocket. If wanted for immediate use, a small quantity of sulphate of zinc may be dissolved in water and added to the porous cup; if not wanted immediately, the battery may be short circuited by connecting the zinc and copper elements by a piece of copper wire, and it will attain its full strength in ten or twelve hours. A little sulphuric acid dropped in the porous cup will answer just as well, if sulphate of zinc is not on hand. The chemical action of this battery is as follows: The zinc decomposes the water, forming oxide of zinc and liberating the hydrogen. The oxide of zinc attacks the sulphate of vitriol, depriving it of the acid, which forms sulphate of zinc, and leaving it as oxide of copper; the oxide of copper is thereupon attacked by the hydrogen, which combines with the oxygen and forms water, while the metallic copper falls to the bottom as a fine powder. It will thus

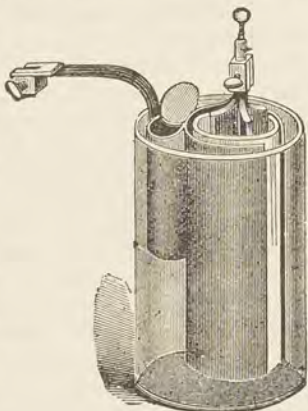

Fig. 118.

be seen that action is simple and continuous, no fumes are given off, and all that is required to maintain the action is a regular supply of copper sulphate to keep the fluid in the outer jar, near the point of saturation. The most prominent fault of this battery is the tendency of the copper to fill the pores of the cup, and thus decrease the action of the battery. It can be partially prevented by coating the bottom and about a quarter of an inch of the sides of the porous cup with wax, and brushing off the deposit as fast as it is formed. The battery should not be allowed to stand on open circuit without the zinc element being removed, and the sulphate of zinc solution in the cup should not be heavier than 25° B, nor lighter than 15° B. If these precautions are observed, the battery should give a constant and free current as long as any zinc remains. Its electro-motive force is about 1.07 volt, and a gallon cell will give about one-half ampere, when in good order, on a short circuit. Its internal resistance varies, but should not be allowed to exceed three to five ohms.

The Gravity Battery. In consequence of the trouble caused by the precipitation of the copper on the porous cell in the Daniell battery, Cromwell F. Varley, in 1854, while experimenting, found that the difference in specific gravity between solutions of sulphate of copper and sulphate of zinc was sufficient in itself to entirely separate them, the copper solution lying at the bottom of the cell, and the zinc solution remaining

superposed upon it. He accordingly dispensed with the porous cup, placed his copper element at the bottom, and the zinc near the top of a glass jar, and thus originated the gravity battery of to-day. It is the simplest, most reliable and constant form known, and has displaced all others for closed circuit work, requiring a low voltage, such as telegraphing, etc. Its voltage, when first set up, is 1.07, running down under constant work to .90, and a gallon cell will give one-half ampere on short circuit. The form of cell shown in Fig. 119 is known as the "crowfoot," on account



Fig. 119.

of the manner in which the zinc (positive) element is spread out, to expose a large surface of zinc to the solution. It is the form used for telegraphing, and, therefore, can be readily attained anywhere. Of course, other forms, shapes and sizes can be made at the option of the workman. To set up this battery, the copper strip, being unfolded so as to form a cross, is placed at the bottom of a jar, the zinc is suspended from the top as shown, and clean water, containing one-tenth of a saturated solution of sulphate of zinc is added, until it nearly touches the zinc. Sulphate of copper crystals are then

added one by one until, if the battery is meant to be continually used, they nearly cover the top of the copper strip. If the battery is not intended for continual use, it will be found more advantageous to use but a few ounces of sulphate of copper, as the more concentrated the solution, the greater is the tendency to local action. The sulphate of zinc may be dispensed with if the battery is not required for immediate use; in this case, the latter should be short circuited, and left so for several days. The need of blue vitriol will be indicated by the discoloration of the lower stratum of the liquid. It is best to keep the line marking the two solutions about halfway between the zinc and copper. Should the sulphate of zinc become too concentrated, a portion of it should be removed by means of a syringe or cup, and its place supplied by water. To determine when this is necessary, a hydrometer may be used. Below 15° the solution is too weak; above 25° it is too strong, and should be diluted. If the battery is taken care of from month to month, it should not require a thorough cleaning more than once a year. When this is done the deposits formed upon the surface of the zinc should be scraped off, the jars washed and the liquids renewed as in the beginning.

If, however, the batteries are in constant use, care must be taken to keep the zincs clean and the solutions as indicated above. If the sulphate of zinc is allowed to become saturated, it will crystallize on the zinc and on the edge of the jar, gradually creeping over the edge. This should be wiped off with a damp cloth and a little oil or fat smeared over

the top of the jar to prevent creeping. The jars should not be disturbed, as this would cause the two solutions to mix, and they should be kept in a dry, even temperature, (60° to 80° F). Freezing would stop the action of the battery.

The Bunsen, or Carbon Battery. Fig. 120, consists of a glass jar containing a hollow zinc cylinder, slit on one side to allow a free circulation of the solution; within this stands a porous cup containing a bar of carbon. To charge this battery, the amalgamated zinc is placed in the glass jar, the porous jar in the center of the zinc cylinder and the carbon in the porous jar. In the outer jar is sulphuric acid, diluted with twelve times its weight of water and in the porous jar electropon fluid. (See *Electropon Fluid*, page 143).



Fig. 120.

The voltage of this battery is 2.028; its amperage cannot be given, as it depends largely upon the care which is given the battery, the size of the cell and the condition of the porous cups, which vary greatly in porosity and conducting power. It emits fumes of hydrogen and sulphurous acid if not in good condition, and should not be used in the same room with fine tools or metal work that is liable to injury. It soon runs down, requiring recharging every day when in constant use, but is simple to handle when understood and is generally furnished in small outfits for nickel plating, etc., on account of its high voltage and the quantity of current given off when in good order. The zincs must be kept well amalgamated or they will polarize very rapidly and destroy the current; care should also be taken that no sediment be allowed to accumulate in the porous cup and fill its pores, thus stopping the action. It is more expensive to run than the gravity, as the zincs are eaten by the acid much faster, especially if not kept well amalgamated; but it will deliver a greater quantity of current in a given time than a gravity cell of equal size. The internal resistance of a new cell is about one-half an ohm. The plates should be removed and cleaned when the battery is not in use.

The Smee Battery. Fig. 121, consists of two plates of amalgamated zinc, between which is placed a silver plate coated with platinum, the object of the platinum being to fill the surface of the plate with innumerable fine points which aid in discharging the bubbles of hydrogen which would cling closely to it if the plate were smooth and thus polarize the battery. This battery is charged with a solution of one part sulphuric acid to seven of water. The plates are connected to the clamp and

placed in jar. In this battery, above all, the precaution of amalgamating the zinc should never be neglected. With an unamalgamated zinc the results are very unsatisfactory.

The voltage of the Smee, when not in action, is 1.09 volts; when in action it runs down to .482 volts; this is caused by the hydrogen clinging to the plate as described. This was the form of cell generally used before the introduction of dynamos for electrotyping and other heavy work, and it is still used to a large extent. It emits fumes of hydrogen when in action, but it is a single fluid battery and when working in large sizes, plates 12x12 inches in size are suspended in a large tank of acidulated water, first a plate of zinc, then a plate of platinized silver, then another of zinc and so on alternately, zinc and platinum, to the end. This gives great facility in handling, as any number of plates to suit the work may be placed in the tank. As there is but one tank and the plates may be placed close together or far apart as required, the resistance may be easily made to balance that in the depositing tank, and thus the work will be performed under the most favorable conditions.

In working the Smee, or any other battery for that matter, large tanks are better than small ones, provided that the plates are kept close together so as to reduce internal resistance of the battery. In the large Smee, if plates 12x12 are worked in a tank say 15x15x30, it will not be long before the sulphate of zinc, which forms and falls to the bottom, will soon commence to rise in the tank, thus shutting off the acid from a portion of the plates and reducing the quantity of current. If the same plates were worked in a tank 24x24x30, the tank might be permitted to become half full of zinc sulphate before the action would be impaired at all, and thus a much more even and constant current would be maintained; this is generally done in practice. In a gravity battery, however, the tank ought not to be deep, because the two elements should not be more than eight inches apart on account of the increased resistance caused by the separation. The tank, however, may be made large enough in length and width to contain elements of the desired size, or a number of standard zincs and coppers, if such an arrangement seems desirable, either to increase the facility of handling or to reduce the cost of a large number of jars, wires, connections, etc. We have seen a number of tanks made of wood, lined with lead, 10x10x60 inches, in which a single large copper element was placed at the bottom and a number of zincs hung as required from an insulated copper bar across the top. It seemed to work well and was convenient.

A few words as to coupling batteries may be of service. It should be born in mind that the quantity of current flowing in any circuit is the quotient resulting from dividing the voltage by the total resistance in that



Fig. 121.

circuit and that the resistance may be increased or diminished by increasing or diminishing the distance between the elements of the battery and between the anode and cathode in the plating vat; also that the resistance varies inversely, as the surface of the elements immersed. Thus a plating surface of one square foot in the plating vat will offer four times as much resistance as four square feet. It thus becomes possible by increasing or diminishing the voltage of a current to keep the



Fig. 122.

current flowing in the desired quantity, and by keeping the resistance in the battery about equal to that in the vats the highest economy is obtained.

For example, let us take eight cells, having a voltage of 1, and giving say $\frac{1}{2}$ ampere per cell on short circuit. If we now couple them —, +, —, +, —, +, —, +, we shall have the voltage of 8 and the amperage of one cell of the same size with a voltage of eight, in other words, the same amount of current and eight times the strength of the single cell, as in Fig. 122.

This is termed coupling in series, and would be used in solutions having a high resistance and small amount of surface immersed. If, on the other hand, the solution had a low resistance and large surface exposed, so that the voltage of one cell was ample to force the current

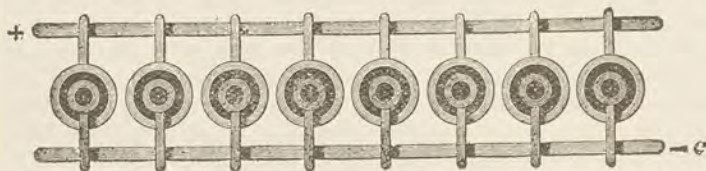

Fig. 123.

through the circuit, they should be connected +, +, +, +, +, +, +, +, and —, —, —, —, —, —, —, —, giving the quantity of eight cells and the voltage of one, which amounts to nearly the same thing as if a single battery having eight times the surface of the single cell were used. This is termed coupling in multiple, Fig. 123. Similarly, if they were coupled +, —, +, —, +, —, +, — and +, —, +, —, +, —, +, — and those two were joined as in Fig. 124, we should have the equivalent of a battery possessing a voltage of four, and elements twice the size of the single cell. This would be spoken of as a battery of eight cells in series

of four. Also four multiples, in series of two, might be arranged to give a voltage of two and quantity due to cells of four times the size of a single cell, as shown in Fig. 125. As the amperes of current passing per second depends upon the voltage, divided by the number of ohms resistance, in the circuit, it will be seen that the current can be controlled by coupling and by manipulating the resistance.

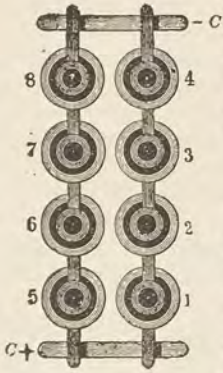

Fig. 124.

of nitric acid; when the solution is complete, add three lbs. more of hydrochloric acid. The zinc is amalgamated by immersing it in this solution for a few seconds, quickly removing to a vat of clear water and rubbing it, as in the first case, with a brush or cloth. If the solution is kept in a covered vessel it may be used a number of times.

In all batteries in which acids are used the zincs should be kept well amalgamated and should be removed from the solution when not in use. This is very important and should not be overlooked.

Improved Electroplating Fluid. Add one part (by volume) of sulphuric acid to 10 parts of water. Of 10 pounds (or pints) of the dilute acid,

add from 1 to 2 pounds of chromic acid, according to the strength of current desired. Where constant action over a long time is desired, rather than maximum energy, omit part or all of the sulphuric acid.

Bichromate of potash is no longer used for batteries by intelligent workers. It owes its virtues to a small amount of chromic acid which can be obtained from it by reaction. Pure chromic acid is cheaper for the same work, and is free from many of the difficulties attendant on the use of the bichromate.

Connections. Having a knowledge of the theoretical action of the battery, the next question is the connections. Cleanliness cannot be too

To Amalgamate Zincs. This may be very well done by first immersing the zincs in a solution of dilute sulphuric acid and then in a bath of mercury. A brush or cloth may be used to rub them, so as to reach all points of the surface. Where a large quantity is to be amalgamated, the following will be found to be a good method: Dissolve eight ounces of mercury in a mixture consisting of two lbs. of hydrochloric and one lb.

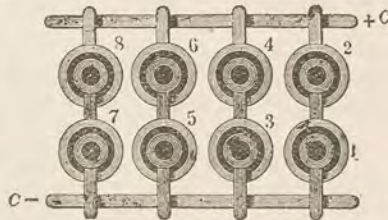

Fig. 125.

strongly insisted upon in making joints, &c. The plater should make it an invariable rule to see that all surfaces of wires, screws, etc., through which the current must pass, be kept bright on the surfaces, through which electrical contact is made. When joining wires they should be brightened with a file, or with emery cloth, and then twisted firmly together with a pair of pliers; all permanent connections should be carefully soldered and the holes and the ends of screws in binding posts should be kept bright; and if for permanent use all conducting wires should be of pure copper, well insulated. The following table shows in the last column the loss of current in wires carrying an economical amount of current; if the wire be too small this loss is rapidly quadrupled until the wire burns. The economy of using large and short connections will be apparent after a slight study of this table.

Table showing the Weight, Carrying Capacity and Loss in Volts of different sizes Copper Wire.

Brown & Sharpe's Gauge No.	Diameter in Thousandths of an inch.	Pounds per 1000 feet bare wire.	Approximate weight Underwriters' re- sultation, per 1000 feet.	Safe Current in Am- peres.	Loss in Volts per Ampere per 100 feet of line (2 Wire.)
0000	.46	640.5	825 lbs.	312.	.0098
000	.40964	508.5	610 lbs.	262.	.0123
00	.3648	402.8	458 lbs.	220.	.0155
0	.32495	319.6	385 lbs.	185.	.0196
1	.2893	253.4	308 lbs.	156.	.0247
2	.25763	201.0	249 lbs.	131.	.0311
3	.22942	159.3	201 lbs.	110.	.0392
4	.20431	126.4	163 lbs.	92.3	.0495
5	.18194	100.2	133 lbs.	77.6	.0624
6	.16202	79.46	109 lbs.	65.2	.0787
7	.14428	63.01	90 lbs.	54.8	.0992
8	.12849	49.98	74 lbs.	46.1	.125
9	.11443	39.64	62 lbs.	38.7	.158
10	.10189	31.43	52 lbs.	32.5	.199
11	.090742	24.93	43 lbs.	27.3	.261
12	.080808	19.77	36 lbs.	23.	.316
13	.071961	15.68	30 lbs.	19.2	.399
14	.064084	12.43	25 lbs.	16.2	.503
15	.057068	9.86	21 lbs.	13.6	.634
16	.05082	7.82	18 lbs.	11.5	.799
17	.045257	6.20	15 lbs.	9.6	1.088
18	.040303	4.92	13 lbs.	8.1	1.271

No matter what battery be used, there are several preliminary conditions that must be complied with in order to produce satisfactory results, i. e. that the deposition may adhere firmly and take place uniformly. It is absolutely necessary that the pure metallic surface of the article be exposed, and that it be perfectly free from grease. The articles to be plated, if lustrous surfaces are desired, must first be ground and polished. The grease must be removed from the surface by boiling in potash or caustic soda, and this is followed by scouring with freshly burnt lime, pulverized thoroughly and free from all grit. If the article will not stand heat, cleanse with benzine. In order to free the surface of non-metallic substances, if the article be of iron, steel or silver, dip it in a mixture of 1 part by weight of sulphuric acid, to 15 of water; if copper or brass, the articles are first dipped in dilute sulphuric acid, and then in a mixture of 100 parts, by weight, of nitric acid, 50 of sulphuric acid, 1 of common salt and 1 of soot. As soon as the surface of the article assumes a bright appearance, it is washed in clean water once or twice, avoiding handling with the fingers or greasy cloths. Wooden plyers, kept clean, serve well for handling.

Avoid the injurious fumes produced by the acids, by operating in the open air or in the draft of a chimney. In order to determine whether the article is entirely free from grease, dip it into water, and if all grease is removed, the water will adhere uniformly; if, however, lines and spots appear, the article is not thoroughly clean, and must again be put through the cleansing process.

Copper. Perhaps the most useful solutions for the plater are the cyanide copper solution, and the cyanide brass or bronze solution. The acid copper solution generally used, which is merely sulphate of copper dissolved in water, is easily made and used, but has numerous disadvantages when compared with the cyanide. It will deposit faster, but leaves a rough and crystalline surface, and cannot be used on steel, as the latter metal is electrically opposed to copper in the presence of sulphuric acid, and sets up a local action which throws off the deposit in scales as fast as it is formed.

The cyanide solution deposits a smooth, even and firm coating, takes equally well on steel, brass or other surfaces, and is capable of so many variations that it may be regarded as the basis of all brass, bronze and copper plating. It is also the only sure means of making a firm deposit of silver or gold on steel. Articles of iron or steel should first be given a light coating of copper, and then the gold or nickel will be held firmly, evenly and smoothly, so that lighter coatings of the more expensive metals will wear longer and look better than a thicker deposit directly on the steel.

The old formulæ for cyanide of copper solutions, all recommend mixing acetate of copper with carbonate and bisulphite of soda, and then

adding potassium cyanide to the carbonate of copper thus formed. This encumbers the bath with a number of useless secondary reactions, and makes it liable to get out of order. It is much better to buy carbonate of copper from a dealer in platers' supplies. It is cheaper than the acetate, and does not put anything in the solution which is unnecessary

To make the solution, use to each gallon of water:

Carbonate of copper.....	7 ozs.
Carbonate of soda.....	2 ozs.
Cyanide of potassium (chemically pure).....	8 ozs.

Dissolve about nine-tenths of the cyanide of potassium in a portion of the water, and add nearly all of the carbonate of copper, previously dissolved in a portion of the water; then add the carbonate of soda, also dissolved in water, slowly stirring until thoroughly mixed. If you have a hydrometer, make your solution to 16° B., then put in a small article and test your solution, adding cyanide or copper, or both, until the solution deposits freely and uniformly.

This may be regarded as a stock solution, and if much work is done, it is best to use it as a basis and make others from it, keeping them separate.

Brass. Brass solutions of any desired color may be made by adding carbonate of zinc, in varying proportions, to the above solution. One part of zinc and two of copper carbonates will give a beautiful golden yellow brass, and should be used with an anode of the same color. If, however, the plater desires to match colors on repairing jobs, etc., he can get any desired color from this bath by varying his current; a strong current will deposit more zinc than copper, giving a paler color of brass in the deposit; and a weaker current will deposit more copper than zinc, giving a redder deposit. In this way most repair jobs can be matched in color, although it is better, when doing new work, to make your solution of the color desired, and use an anode of the same color, as by doing so you put the two metals into the solution in the same proportion as you are taking them out. If you are using copper anodes, it is best to buy the electrically deposited anodes from a dealer in platers' supplies, as they cost no more, are always pure, and deposit much freer and smoother than the hard rolled copper for sale at metal houses. The same thing also applies to anodes of brass, gold or silver, but in less degree.

Management. Those who have never used the cyanide bath may desire some additional particulars regarding its management. The anodes in such a bath generally carry a slight greenish coating, consisting of copper cyanide. This is soluble in the free cyanide that is in the bath, and only traces of it should appear on the anodes. When the cyanide is used up, this green coating thickens up rapidly, and the bath, shortly afterwards, stops depositing. In such case, add cyanide (dissolved in water) very slowly, in order not to get in too much.

If too much cyanide is in the bath, bubbles of hydrogen will come from the objects to be coated, but no copper will be deposited, and the remedy is adding carbonate of copper.

If either of the above does not give a rapid and even coating, the bath needs more metal, and you are likely using too small an anode and stripping your bath. The remedy is, of course, found in adding more carbonate and using a larger anode.

Gold Baths. Both warm and cold baths are used, the former being preferable, as they yield denser depositions, require less strength of current, and need not be so rich in gold as cold baths. Many platers prepare gold baths by dissolving $3\frac{1}{2}$ ounces of chemically pure cyanide of potassium in a quart of distilled water, and connecting two cells of Bunsen battery with two gold anodes, and working it until the solution contains 32 grains of gold to the quart of water, which can be told by weighing the anodes from time to time. It does not give as bright a color, however, as dissolving an equivalent quantity of chloride of gold in the cyanide, owing to the presence of silver and copper in the gold anodes, and consequently in the bath. In purchasing your chloride of gold, where possible get the brown neutral variety, as it is preferable to others, as it contains less acid.

A good warm bath is prepared as follows: Neutral chloride of gold, 7 pennyweights; 99 per cent potassium cyanide, 33 grains; water, 1 quart. Dissolve the potassium cyanide in one-half of the water and the chloride in the other half, mix both solutions, and boil for half an hour, replacing the water lost by evaporation. The solution will last indefinitely if the anode used is large enough to make up for the gold used. When the anode is covered with a slight coating in the bath, it shows a want of cyanide of potassium, which is best added by dissolving an ounce of chemically pure cyanide in a pint of water, and adding a little at a time, until the bath works all right again. Too much free cyanide in the bath gives an ugly, pale color and irregular deposit.

A cold solution will give a pale color; increasing the temperature to 140° gives a reddish color; 120° to 130° gives a fine yellow. The reason of this is that heat hastens the chemical reactions in the bath, and the gold deposits much more rapidly, so the operator should look out not to deposit more gold than he wants, and thus strip his solution. The anode surface should also be less with the hot solution.

Changes of color can also be made by increasing the current and anode surface in a cold solution, by putting in some sort of resistance in the circuit for the paler colors, and withdrawing it for the redder ones. As anodes, it is best to use sheets of fine gold, which gradually dissolve, and thus convey fresh metal to the bath. The current must not be so strong that a formation of bubbles is perceptible; it is best to use a current of such strength only that deposition takes place slowly, a coating

of the greatest density being thus obtained. Avoid using cheap and inferior chemicals, as the difference in price is more than offset by the time and damage that often results from inferior grades. To obtain good results, always use as pure water as possible, filtered rain water being the most desirable. The best temperature for cold baths is 66° F. Care should also be taken to see that the baths are covered with cloths to exclude dust, and where it does penetrate, the baths should be skimmed off.

Only copper, brass and bronze can be directly gilded; other metals must first be coppered or brassed; this applies to good work. In gilding parts of watches, gold is seldom directly applied upon the brass; there is generally a preliminary operation called graining, by which a slightly dead appearance is given to the articles. They are thoroughly finished, all grease removed as described above, threaded upon a brass wire, cleansed in the compound acids for a bright luster, and dried in sawdust. The pieces are fastened upon the flat side of a piece of cork by means of brass pins, and the parts are thoroughly rubbed over with a clean brush dipped in a paste composed of fine pumice stone powder and water. The brush is moved in circles, in order to rub evenly. Thoroughly rinse in clean water in order to remove every particle of pumice stone, both from the article and the cork. Place the whole in a weak mercurial solution, composed of nitrate of mercury, 4 grains; water, 9 quarts; sulphuric acid, 1 dram; which will slightly whiten the brass. Pass quickly through this solution and then rinse. After the parts are grained in the manner described, they may be gilded the same as ordinary work.

Carat Baths. The plating baths of a large establishment are made up to have the same alloy in them as is intended to be used in the anode, that is, 18k, 16k, 14k, etc., by adding cyanide of copper and cyanide of silver, or chloride of silver, to the gold bath above described. Or it may be made by battery, as described above, and any article intended to receive a certain quality of plate is put into its appropriate bath, weighed from time to time, and when it has received the allotted number of pennyweights, is given to the finishers.

Red Gold. A solution of copper cyanide in potassium cyanide is added to the gold bath in small proportions, until it assumes the color desired.

Green Gold. Add cyanide or chloride of silver to the gold bath, until it assumes the desired color; or suspend silver anodes beside the gold anodes.

Coloring is always done with pure gold, and the best workmen take especial pains to see that no silver or copper is allowed in the solution. They do this by using only the best chemicals, and frequently evaporating their baths and parting out the silver with nitric acid. By this means they obtain an immense advantage over others, in the brightness and thinness of the coating of gold deposited.

The durability of gold plating does not depend altogether on the time it is in the solution. If the current is about two to three volts (about equal to a Bunsen cell, or two Smee cells connected, for intensity) and the quantity is proportioned to the work in the bath, then if the solution be worked at 120° to 130°, which also deepens the color of the deposit, it is possible to get a coat inside of five minutes that will last for several years.

It is always best, when other conditions are all right, to keep the work moving, and immerse the gold anode gradually, to suit the surface of the work that is being plated; care should be taken not to allow the work and anode to touch each other, as a black or burned spot will be left on the work wherever the anode touches it.

After getting the first slight coat of gold, the work should be scratch brushed with a fine brass scratch brush (wire about .003 inch), letting a little soap suds drip on the brush. This lays down the first coat of gold, which should be sufficient to cover the article entirely. The scratch brush acts as a burnisher. After this it is thoroughly cleaned of the soap suds in hot water, and again placed in the solution. The time it remains will have to be governed by experience, but generally five minutes will give a sufficient coat to stand burnishing.

Burnishing may be done with steel and agate burnishers, same as with silver, or the articles may be polished with a soft cotton flannel wheel, run at 2,500 revolutions per minute, and bearing a very little of the finest rouge, mixed with alcohol. If you run your wheel too slow the layers of cotton will not stand up, and you will not get a polish; 2,500 to 3,000 revolutions is about right, and the pressure should be light and even.

Silver Baths. For ordinary plating 7 pennyweights of fine silver (11 pennyweights of nitrate of silver, or 9 pennyweights of chloride of silver), is dissolved in a solution of 33 grains of 98 per cent potassium cyanide in 1 quart of water. For heavy silvering of knives, forks, etc., a stronger bath is used: 17½ pennyweights of fine silver (1 oz., 4 pennyweights of chloride of silver, or 1 oz. 15 grains of cyanide of silver,) is dissolved in a solution of 1 oz. 15 pennyweights of 98 per cent potassium cyanide in 1 quart of water. No accurate statement can be made in regard to the quantity of potassium cyanide in the bath, as it depends on the strength of the current used. With a very weak current, and consequently slow

precipitation, somewhat more potassium cyanide may be used than with a stronger current and more rapid precipitation. The anodes, for which fine silver is used, will indicate by their appearance whether the bath contains too much or too little potassium cyanide. They should become gray during silvering, and gradually resume their white color after the interruption of the current. If they remain white during silvering, the bath contains too much potassium cyanide, and, if they turn black, and retain this color after the interruption of the current, potassium cyanide should be added.

The article to be silvered should be moved constantly to avoid the formation of streaks. Before silvering the metals must be prepared by amalgamation. This is done by dipping the articles, previously freed from grease, as explained above, in a dilute solution of mercurous nitrate (30 to 150 grains per qt.) allowing them to remain in the solution only long enough to become uniformly white. Rinse them in water, brush off with a clean soft brush, and immediately place in the striking bath.

Silvering of iron and steel is best accomplished by using a striking solution made as follows: $\frac{3}{4}$ of an oz. of C. P. chloride silver, 6 oz. C. P. cyanide of potash, 1 gallon water. After thoroughly cleaning hang the articles for a few minutes in the solution, using a large silver anode surface. The hydrogen gas should escape freely from the surface of work and as soon as covered with a yellowish deposit of silver, which is very adhesive, transfer to the standard solution, which can be made from the concentrated solution. From this no gas should escape, and the anode surface should be about the same as surface of work. A Bunsen or three Smee batteries connected for intensity can be used for the striker, and one Smee cell for standard solution, zinc surface of same equalling that of work.

The articles remain in the bath from ten to fifteen minutes, when they show a uniformly white surface; they are then taken out, scratch-brushed with a brass brush to see that the deposit adheres, all grease removed, and then placed in the bath. After the current is shut off, the articles should be left in the bath a few seconds to prevent the deposit from turning yellow.

If the articles are not to be burnished, but are to be left with a mat as they come from the bath, they must be thoroughly rinsed in water without coming in contact with the fingers or the sides of the vessel, then dipped in clean hot water and hung up to dry. They then should be coated with a colorless laquer to prevent turning yellow. If the articles are to have a polished surface, they are to be finally scratch-brushed with frequent moistening with soap-root, dried in warm sawdust and burnished with a steel or stone burnisher.

Nickel Baths. Iron and steel must be prepared by immersing in a hot solution of caustic soda or potash, thoroughly brushed, rinsed in

water and dipped in a pickle of 1 part sulphuric acid, 2 parts hydrochloric acid and 10 parts of water, again rinsed, thoroughly rubbed with fine well washed pumice stone or Vienna lime, again rinsed and put in the bath. If finely polished tools, they may be brushed with whiting or tripoli instead of pumice stone. Copper wire should be tightly wound around all metal articles. Small articles may be suspended from copper hooks. The battery or dynamo is placed in action before immersing the articles, which remain in the bath until they have acquired a white appearance, which will be in from five to thirty minutes, depending on the strength of the current and the size of the article. In case the article assumes a gray or black color, or feels rough and gritty, the current is too strong, or if it assumes a yellowish white appearance, it is too weak. The simplest nickel bath consists of a solution of pure double sulphate of nickel and ammonium 8 to 10 parts by weight in 100 parts of distilled water. Boil the salt in a corresponding quantity of water, say 8 to 10 parts of nickel-salt to 100 of water, depending on the temperature. With this bath cast nickel anodes and a strong current should be used. When a pure white deposit is required on unpolished surfaces the addition of 2 oz. of pure chloride of nickel to each gallon of the above solution is recommended. On an article of iron, steel, lead or its alloys a previous slight deposit of copper from a cyanide solution is advisable. It adds scarcely anything to the cost and insures a uniform coating which is not always apparent in a deposit on a light colored metal. The article after its removal from the bath should be dipped for a few seconds in boiling water, drained and dried in warm sawdust. They may then be polished, but cannot be burnished. The luster on nickel-plated objects depends greatly on the polish given them before plating. The composition of nickel baths depends greatly upon the metals to be operated on, which can best be determined by experiment. The anodes should be suspended by strong hooks of pure nickel wire, and the articles should be placed at a distance of from $3\frac{3}{4}$ to $4\frac{3}{4}$ inches from them. If the article is to receive a thick deposit, it should be turned in the bath from time to time, from end to end, so that those portions which were down come up. Small articles which cannot be suspended are placed in a sieve, it being preferable to use a heated bath for the purpose. Iron, steel, copper, brass and bronze are usually nickeled directly, but Britannia ware, zinc and tin are coppered or brassed before nickeling. In case a freshly prepared bath yields a dark deposit it can generally be remedied by working the bath for two or three hours.

Doctoring. This term is applied to plating defective places which occurred either by accident or negligence on the part of the operator. It is equally applicable to gold, silver or nickel plated articles. Take a piece of the anode, be it gold, silver or nickel, about the size of your little finger and connect it with the positive pole by a thin copper wire.

Around this anode wrap a piece of ordinary muslin several times; hold the defective article on the top of the positive pole, and after dipping the anode in the solution until the muslin is thoroughly soaked, move it to and fro over the defective place, and a coating is thus formed.

Recovery of Gold from Bath. To recover gold from bath evaporate the bath to dryness, mix the residue with litharge and fuse the mixture. A lead button is thus formed in which all the gold is contained. Dissolve the button in nitric acid, and the gold will remain behind in the form of small flakes. Filter off and dissolve the flakes in aqua regia.

Recovering Gold from Coloring Bath. Dissolve a handful of sulphate of iron in boiling water, and add to it your "color" water; it precipitates the small particles of gold. Now draw off the water, being very careful not to disturb the auriferous sediment at the bottom. You will now proceed to wash the sediment from all traces of acid with plenty of boiling water; it will require three or four separate washings, with sufficient time between each to allow the water to cool and the sediment to settle, before passing off the water. Then dry in an iron vessel by the fire and finally fuse in a covered crucible, with a flux.

Recovery of Silver from a Bath. To recover silver from cyanide bath; evaporate the bath to dryness, mix the residue with a small quantity of calcined soda and potassium cyanide and fuse in a crucible, and the metal will be found in the form of a button in the bottom of the crucible.

Antique Green. An imitation of antique bronze can be applied to new articles by the following process: Dissolve 3 parts of common salt, 1 part of sal-ammoniac and 3 parts of powdered tartar in 12 parts of boiling water. Add 8 parts of a solution of cupric nitrate, and coat the articles with the liquid.

Black Bronze for Brass. 1. Dissolve one oz. of copper carbonate in $8\frac{3}{4}$ fluid ounces of spirit of sal-ammoniac. Add one pint of water and stir constantly. The articles to be colored should be suspended in the liquid by means of brass or copper wires for a short time. The coating adheres better if the articles are polished with coarse emery paper.

2. Brush the brass with a solution of nitrate of mercury, and then several times with a solution of liver of sulphur.*

Blue Bronze. Cleanse the metal from all grease by dipping in boiling potash lye and afterwards treat it with strong vinegar. Wipe and

*Fused sulphuret of potassium, so called from its resemblance to liver in color.

dry the article thoroughly, and rub it with a linen rag, moistened with hydrochloric acid. Allow the coating to dry for a quarter of an hour, and then heat the article on a sand bath, until it assumes the desired color, when it should be removed.

Bronze for Small Brass Articles. Oxide of iron, 3 parts; white arsenic, 8 parts; hydrochloric acid, 36 parts. Clean the brass thoroughly and apply with a brush until the desired color is obtained. Oil well and finish by varnishing or lacquering.

Bronze Liquid. Dissolve sal-ammoniac 1 oz.; alum, $\frac{1}{2}$ oz.; arsenic, $\frac{1}{4}$ oz.; in strong vinegar, 1 pt. The compound is immediately fit for use, and, where the metal is good, is seldom found to fail.

Bronze for Medals. The following process of bronzing is carried on in the Paris mint. Powder and mix 1 pound each of verdigris and sal-ammoniac. Take a quantity of this mixture, as large as a hen's egg, and mix into a dough with vinegar. Place this in a copper pan (not tinned), boil in about 5 pints of water for 20 minutes, and then pour off the water. For bronzing, pour part of this fluid into a copper pan; place the medals separately in it upon pieces of wood or glass, so that they do not touch each other, or come in contact with the copper pan, and then boil them in the liquid for a quarter of an hour.

Bronze for Steel. Methylated spirit, 1 pint; gum shellac, 4 ounces; gum benzoin, $\frac{1}{2}$ ounce. Set the bottle in a warm place, with occasional agitation. When dissolved, decant the clear part for fine work, and strain the dregs through muslin. Now take 4 ounces powdered bronze green, varying the color with yellow ochre, red ochre and lamp black, as may be desired. Mix the bronze powder with the above varnish in quantities to suit, and apply to the work, after previously cleansing and warming the articles, giving them a second coat, and touching off with gold powder, if required, previous to varnishing.

Brown Bronze. Brown bronze is prepared the same as blue bronze but the blue bronze is finally rubbed over with a linen rag saturated with olive oil, which will change the blue color into brown.

Brown Stain for Copper. To produce a dark-brown color upon copper, take the white of an egg, beat it into froth, add a little boiled or rain water, and add to this mixture *caput mortuum* (red oxide of iron); rub them well together in a mortar, and sufficiently thick until the color covers, and may be applied. The copper articles are to be pickled and simply washed; no sand must be used, else the color adheres badly. The latter is next applied with a brush until it covers the surface it is

then dried by a fire, the article is gently rubbed with a soft rag and *caput mortuum* powder, and finally hammered with a hammer with polished face.

Brown Stain for Gun Barrels. Mix 12 parts of a solution of sulphate of iron, 16 parts of sulphate of copper, 16 parts of sweet spirit of nitre and 12 parts of butter of antimony. Let the mixture stand in a well corked bottle for twenty-four hours and then add 500 parts of rain water. Thoroughly polish and clean the barrels, wash with fresh lime water, dry thoroughly and apply the mixture evenly with a piece of cotton. After drying for twenty-four hours, brush with a scratch brush and repeat the coating. Do this twice, the last time using leather moistened with olive oil in lieu of the scratch brush, rubbing thoroughly. After standing for ten or twelve hours, repeat the polishing with sweet oil and leather until a beautiful polish is obtained.

Chinese Bronze. Small articles bronzed by this process possess a peculiar beauty, and lose none of their luster, even when exposed to atmospheric influences and rain. Powder and mix thoroughly 2 parts of crystalized verdigris, 2 parts of cinnabar, 2 of sal-ammoniac, 2 of bills and livers of ducks, and 5 of alum. Moisten the mixture with water or spirit of wine, and rub into a paste; cleanse the article to be bronzed thoroughly, and polish with ashes and vinegar. Then apply the paste with a brush. Heat the article over a coal fire, and wash the coating off. Repeat this operation until the desired brown color is obtained. By adding blue vitriol to the mixture, a chestnut brown color is produced, while an addition of borax gives a yellowish shade.

Gold Bronze for Iron. Dissolve three ounces of finely powdered shellac in $1\frac{1}{4}$ pints of spirit of wine. Filter the varnish through linen and rub a sufficient quantity of Dutch gold with the filtrate to give a lustrous color to it. The iron, previously polished and heated, is brushed over with vinegar and the color applied with a brush. When dry the article may be coated with copal lacquer to which some amber lacquer has been added.

Gold Tinge to Silver. A bright gold tinge may be given to silver by steeping it for a suitable length of time in a weak solution of sulphuric acid and water, strongly impregnated with iron rust.

Gold-Yellow Color on Brass. A gold like appearance may be given to brass by the use of a fluid prepared by boiling for about 15 minutes, 4 parts caustic soda, 4 parts milk sugar, and 100 parts of water, after which 4 parts concentrated solution of sulphate of copper is added with constant stirring. The mixture is then cooled to 79° C., and the

previously well cleaned articles are for a short time laid into it. When left in it for some time they will first assume a blueish and then a rainbow color.

Gray Stain for Brass. Many black and gray pickles possess the defect that they give different colors with different copper alloys, while in the case of certain alloys they refuse to act altogether. For instance, carbonate of copper, dissolved in ammonia, gives to brass a handsome, dark-gray color, while it does not whatever attack various other alloys; therefore it is little suitable for instruments. A dark-gray pickle, which almost indiscriminately stains all copper alloys a handsome gray, resembling in color the costly platinum, is composed by dissolving 50 grams arsenic in 250 grams hydrochloric acid, and adding to the solution 35 grams chloride of antimony and 35 grams finely pulverized hammer scales. The articles to be pickled are rinsed in a weak, warm soda solution, prior to as well as after immersion, to be followed by continued rinsing in water. The recipe is simple, and has been repeatedly tested with uniformly good results.

Green Bronze for Brass. Add to a solution of 8 $\frac{1}{2}$ drachms of copper in one ounce of strong nitric acid, 10 $\frac{1}{2}$ fluid ounces of vinegar, 3 $\frac{1}{2}$ drachms of sal-ammoniac, and 6 $\frac{3}{4}$ drachms of aqua-ammonia. Put the liquid in a loosely corked bottle, and allow it to stand in a warm place for a few days, when it may be used. After applying it to the articles, dry them by exposure to heat, and when dry, apply a coat of linseed oil varnish, which is also dried by heat.

Imitation of Antique Silver. The article is dipped in a bath of water containing about 10 per cent of sulphide of ammonium, and then scratch brushed with a brush made of glass threads or bristles. When afterwards burnished with an agate tool its surface becomes a beautiful dark brown color.

Oxidizing Silver. 1. Place the silver or plated articles in a solution of liver of sulphur diluted with spirit of sal-ammoniac. They are then taken out, washed, dried and polished. This produces a blue-black tint, while a solution of equal quantities of sal-ammoniac and blue vitrol in vinegar gives a brown shade.

2. Sal-ammoniac, 2 parts; sulphate of copper, 2 parts; saltpeter, 1 part. Reduce these ingredients to a fine powder, and dissolve in a little acetic acid. If the article is to be entirely oxidized, it may be dipped for a short time in the boiling mixture; if only in parts, it may be applied with a camel-hair pencil, the article and the mixture both being warmed before using.

3. There are two distinct shades in use, one produced by chloride, which has a brownish tint, and the other by sulphur, which has a bluish-black tint. To produce the former it is only necessary to work the article with a solution of sal-ammoniac; a much more beautiful tint, however, may be obtained by employing a solution composed of equal parts of sulphate of copper and sal-ammoniac in vinegar. The fine black tint may be produced by a slightly warm solution of sulphate of potassium or sodium.

Silvering for Copper or Brass. Mix 1 part of chloride of silver with 3 parts of pearl ash, $1\frac{1}{2}$ parts common salt, and one part whiting; and well rub the mixture on the surface of brass or copper (previously well cleaned), by means of a piece of soft leather, or a cork moistened with water and dipped in the powder. When properly silvered, the metal should be well washed in hot water, slightly alkalized, then wiped dry.

2. Mix three parts of chloride of silver with 20 parts finely pulverized cream tartar, and 15 parts culinary salt. Add water in sufficient quantity, and stir until the mixture forms a paste, with which cover the surface to be silvered by means of blotting paper. The surface is then rubbed with a rag and powdered lime, washed, and rubbed with a piece of soft cloth. The deposited film is extremely thin.

Silvering Small Iron Articles. The small iron articles are suspended in dilute sulphuric acid until the iron shows a bright clean surface. After rinsing in pure water, they are placed in a bath of mixed solution of sulphate of zinc, sulphate of copper, and cyanide of potassium, and there remain until they receive a bright coating of brass. Lastly they are transferred to a bath of nitrate of silver, cyanide of potassium, and sulphate of soda, in which they quickly receive a coating of silver.

Silver Plating Without a Battery. 1. The process consists in exposing the article, which has previously been well cleansed with a potash solution and dilute hydrochloric acid, to the operation of a silver bath, which is prepared in the following manner: Form a solution of 32 grams (1 oz., 13.8 grains) nitrate of silver, 20 grams silver (12 dwts., 20.6 grains) in 60 (1 oz., 18 dwts., 13.9 grains) grams nitric acid. The silver is precipitated as silver oxide with a solution of 20 grams solid caustic potash in 50 grams (1 oz., 12 dwts., 3.6 grains) distilled water, carefully washed, and the precipitate taken up by a solution of 100 grams (3 oz., 4 dwts., 7.2 grains) cyanide of potassium in 500 grams distilled water. The fluid, distilled through paper, is finally diluted with distilled water to 2 liters ($4\frac{1}{2}$ pints). The thus prepared silver bath is gently warmed in the water bath, and the article to be silver plated laid in it and kept in motion for a few minutes, and after taking out it is dried in sawdust, and then polished with Vienna chalk for giving luster.

2. For rapid silver plating, prepare a powder of 3 parts of chloride of silver, 20 parts carefully pulverized cream of tartar, and 15 parts pulverized cooking salt; mix it into a thin paste with water, and rub it upon the well cleaned metallic surface with blotting paper. After you are certain that all parts of the article have been touched alike, rub it with very fine chalk or dust upon wadding or other soft cloth. Wash with clean water and dry with a cloth.

3. Dissolve 1 oz nitrate of silver, in crystals, in 12 ozs., soft water; then dissolve in the water 2 ozs. cyanide of potash, shake the whole together, and let it stand until it becomes clear. Have ready some half-ounce vials, and fill half full with Paris white, or fine whiting, and then fill up the bottles with the liquid, and it is ready for use. The whiting does not increase the coating power, it only helps to clean the article, and save the silver fluid.

4. Make a solution of 4 ounces lunar caustic (equal to a solution 2½ ounces silver in 7½ ounces nitric acid); the silver of this solution is precipitated as an oxide of silver by the addition of a solution of 2½ ounces of caustic potash in 6½ ounces distilled water; and the precipitate, after being washed, is added to a solution of 12½ ounces of cyanide of potassium in one quart of water. This solution is then filtered and water added to bring it to 4 quarts. In this solution, which is heated on the water bath, the pieces to be silvered are left for a few minutes. Being agitated, they are taken out, and put to dry in fine sawdust and then polished.

Steel-Blue on Brass. Dissolve 1½ drachms of antimony sulphide and 2 ounces calcined soda in ¾ pint of water. Add 2¾ drachms of kermes, filter, and mix this solution with another of 2¾ drachms of tartar, 5½ drachms of sodium hyposulphite and ¾ pint of water. Polished sheet brass placed in the warm mixture assumes a beautiful steel-blue.

To Give Copper a Durable Luster. Place the copper articles in a boiling solution of tartar and water for fifteen minutes. Remove, rinse off with cold water and dry.

ELLICOTT, JOHN. A celebrated London clockmaker. He was born in 1700, was elected a fellow of the Royal Society in 1738, and published a work on pendulums in 1751. He invented a compensation pendulum in 1753, in which the bob rested on the longer ends of two levers, of which the shorter ends are depressed by the superior expansion of a brass bar attached to the pendulum rod. The invention, however has not proved of any practical value. He died in 1772.

EMERY. The dark colored and non-transparent variety of corundum. See *Corundum*.

Emery Countersinks. See *Countersinks*.

Emery Files, Pencils and Sticks. Emery files are to be had ready made from all material dealers and consist of wooden handles to which emery cloth is glued. Emery pencils are kept by some dealers and will be found very useful for grinding the inside of metal objects, and also on small work of various kinds, being easy to handle, clean and light. Emery sticks are of two kinds, solid square sticks and round and square sticks of wood to which emery paper or cloth is glued. Emery paper and cloth may be had from most material dealers, varying from 0000 to No. 4.

Emery Wheels. Wheels of solid emery or wooden wheels, to the surface of which emery paste has been applied. The best wheels for watchmakers' use are the solid wheels in which vulcanite is the cementing medium. They may be had from material dealers generally or from dental supply houses, in sizes varying from $\frac{1}{2} \times \frac{1}{8}$ in. to $3\frac{1}{2} \times \frac{3}{4}$ in. A set of three or more of these wheels will prove very valuable

*Fig. 126.*

adjuncts to the watchmaker's bench for grinding dials to allow freedom of motion for wheels in fitting new dials; for grinding milling cutters, drills, gravers, etc. As purchased from dealers these wheels have a central hole, by means of which they can be mounted for use by the watchmaker as follows: Turn down a piece of No. 30, Stubbs' steel wire, to the size of the opening in your wheel and rivet your wheel firmly upon it, as shown in Fig. 126. It can then be used in your lathe very handily, either with or without water. The best sizes for watchmakers use are $\frac{1}{2}$ in., 1 in. and $1\frac{1}{2}$ in. diameter.

END STONE. The small stone disc on which a watch pivot rests, applied principally to escapement and balance pivots. Jewels with end stones are known as capped jewels.

ENGINE TURNING. The wavy, curved lines used as decorations for watch cases. See *Rose Engine*.

ENGRAVING BLOCKS. A mechanical device for holding coins, jewelry, silverware, etc., while engraving. Fig. 127 is the usual form

given to engraving blocks and is known as the flat base variety. Fig. 128 has what is known as the cannon-ball base, but the holding devices are similar to the flat base. Various attachments are furnished for holding rings, spoons, coins, etc.

EPICYCLOID. A curve generated by a point in the circumference of a movable circle, as it rolls upon another circle. The teeth of driving wheels are usually of this form.



Fig. 127.

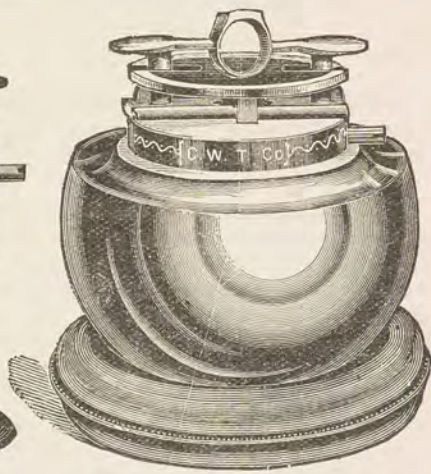

Fig. 128.

EQUATION OF TIME. The difference between mean and apparent, or solar, time.

ESCAPEMENT. The mechanical device in a watch or clock by which the motion of the train is controlled so that the power may be distributed uniformly. Saunier divides escapements into three principal classes: Recoil, Dead Beat and Detached. 1. Recoil escapements are so classed, because at a certain period of this action, the wheel moves backward or recoils in a manner more or less marked. The verge escapement in watches and certain forms of the anchor in clocks, may be used as examples.

2. Dead Beat escapements are so called because except during the actual impulsion, the wheel remains stationary, a point being supported either against the axis of the balance itself, or against the accessory piece, concentric with this axis, which catches it in its movement of rotation. The cylinder and duplex escapements in watches and the pin and Graham escapements in clocks are examples of this class.

3. Detached escapements may be called Dead Beat escapements, but their principal characteristic consists in the fact that the balance performs its vibration in absolute independence of the wheel, except during the very brief periods of impulse and unlocking. The wheel, then, does not rest on the axis of the balance, but on an intermediate and distinct piece. The lever escapement in watches, the detent escapement in chronometers, as well as several forms of escapements employed in clocks, come under this head. See *Anchor, Chronometer, Cylinder, Dead Beat, Duplex, Graham, Pin Pallet, Pin Wheel and Verge.*

ESCAPE PINION. The pinion on the escape wheel staff.

ESCAPING ARC. The angle included in the oscillation of a pendulum or lever from the time one tooth of the escape wheel passes from one pallet to the next.

EYE GLASS. Eye glasses for watchmaker's use are mounted in many different styles. Some have horn, others have vulcanite and still others cork mountings. The vulcanite mounted glass with a light spring attached to sustain it in place is very popular with apprentices. The Clark patent glass, shown in Fig. 129, is becoming very popular in this country. It is provided with an annular reflector, with a central opening and corrugations, and so seated in the outer end of the glass as to reflect the rays of light falling on the outside of it in front of the glass, and concentrating them upon the object being viewed. It is especially useful in examining the inside of watches, as it often occurs that it is difficult to get light sufficient to do so.



Fig. 129.

FACIO, NICHOLAS. A native of Geneva, who discovered the art of piercing holes in rubies, garnets and other stones. He first went to Paris and from there, in 1700, went to London, and there with the brothers Peter and Jacob de Beaufre carried on the business of watch jewellery. A patent on his process of piercing jewels was granted to him in England in May, 1704.



James Ferguson.

FERGUSON, JAMES. A celebrated astronomer and mechanic. He was born in the year 1710, a few miles from Keith, a little village in Banffshire, in the north of Scotland. Ferguson can hardly be classed among horologists, although he made many improvements in the clocks of his day and many inventions in this line. In the year 1750 Ferguson invented and made his celebrated machine, known as the "Mechanical Paradox." This curious machine

was made for the purpose of silencing a London watchmaker who did not believe in the doctrine of the Trinity. The paradox, which is illustrated in Fig. 131, is described by Ferguson as follows: "A is called the *immovable* plate, because it lies on a table whilst the machine is at

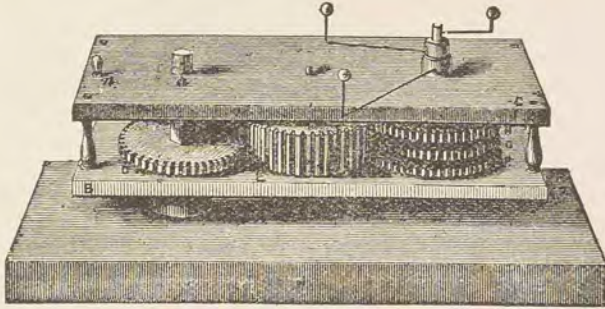

Fig. 131.

work; B C is a moveable frame to be turned round an upright axis *a* (fixt in the centre of the immovable plate) by taking hold of the nob *u*.



Fig. 132.

On the said axis is fixt the immovable wheel D whose teeth take into the teeth of the thick moveable wheel E, and turns it round its own axis as the frame is turned round the fixt axis of the immovable wheel D and in the same direction that the frame is moved. The teeth of the thick wheel E take equally deep into the teeth of the three wheels, F, G and H, but operate on these wheels in such a manner, that whilst the frame is turned round, the wheel H turns *the same way* that the wheel E does, the wheel G turns *the contrary way*, and the wheel F *no way at all*." Fig. 132 illustrates what Ferguson termed "a one-wheeled clock." The drawing he made in 1774 and there was no description accompanying it, simply these few words: "The number of wheels in a clock reduced to one, by means of a double 'scapement.'" This is a problem for the ingenious watch or clock maker to solve. James Ferguson died Nov. 16, 1776.

FERRULE. The small pulley or wheel around which the string of a bow is wound when giving motion to a piece of work. See also *Coll. t.*

FETIL, PIERRE. A noted French Watchmaker, born at Nantes in 1753, and died at Orleans May 18, 1814.

FILES. Files for watchmakers' use are made in every conceivable shape, and in sizes from that of a fine cambric needle to $1 \times \frac{1}{8}$ in. The various styles are known as flat, pillar, joint, three-cornered knife, round, half round, oval, square, smooth cut, barrette, warding, conical, slitting, pivot, ratchet, screwhead, escapement, etc. Escapement files are usually put up in sets of twelve assorted shapes. The average American has a tendency to be extravagant, and in no trade or calling is this extravagance better exemplified than in that of the watchmaker and particularly in the matter of files. Many watchmakers' benches will be found, in the drawers of which, from one to two dozen files will be found, and out of all that number, not to exceed six will be in anything like respectable shape for good work. This is not occasioned by the poor quality of the goods used in this country, because eight out of every ten files used by watchmakers are of French, Swiss or English manufacture, and cost the American more money than his European brother, but rather from a careless handling of these tools, from a want of training. The skilled European watchmaker serves a long apprenticeship to a master who insists that he first becomes proficient in the use of the file, then the graver, etc., before he is allowed to work upon a clock or watch. In this way he acquires a proficiency in the use of tools which the average young American watchmaker is a stranger to. The American watchmaker will employ a new file upon steel work, whereas, the European first employs a new file in working brass or copper and even then handles it very carefully. He would no more think of using a new file upon steel work than he would of flying. A new file, if carefully used, and gradually advanced from a soft to a hard metal, will at the end of six months, be a much better file for steel work than a new one, and will last four times as long. When the surface of a file becomes choked with particles of steel, iron or brass, Saunier advises that it be cleaned as follows: Place the file for a few seconds in hot potash and water, and on withdrawal, dry it before the fire and brush the surface with a stiff brush. If the file has a tendency to fill up, slightly oil the surface by means of a linen rag.

FILING BLOCK. A contrivance made to take the place of the

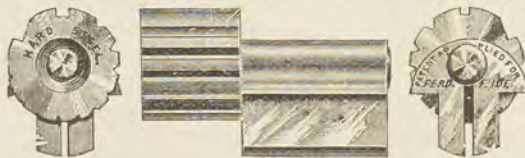

Fig. 133.

filing rest, which was made of boxwood or bone. It consists of a cylinder

of hardened steel rivetted upon a staff which in turn enters a split socket. The surface of the steel cylinder is grooved with various sizes of grooves for the different sizes of wire, or to suit any work, as shown in Fig. 133. The cylinder is revolved until the desired size groove is brought uppermost, when the split socket is placed between the jaws of a vise, and the vice closed, thus holding the cylinder in the desired position. Fig. 133 illustrates Mr. Ide's patent block which is well made and of superior material.

FILING FIXTURE OR REST. These rests will be found very convenient in squaring winding arbors, center squares, etc. There are several makes of these tools, but they are all built upon the same principle,



Fig. 134.

that of two hardened steel rollers on which the file rests, and Fig. 134 is a fair example. One pattern is made to fit in the hand rest after the T is removed, while the other is attached to the bed of the lathe in the same manner as the slide rest. The piece to be squared is held in the split or spring chuck in the lathe, and the index on the pulley is used to divide the square correctly. Any article can be filed to a

perfect square, hexagon or octagon as may be desired. The arm carrying the rollers can be raised or lowered as required for adjustment to work of various sizes.

FLUX. A mixture or compound to promote the fusion of metals; used in assaying, refining and soldering, as alkalies, borax, etc.

FLY OR FAN. A fan having two blades, used for preserving the uniformity of motion, as in music-boxes and the striking mechanism of clocks. The resistance of the air on the fan blades prevents the train from accelerating.

FOLLOWER. Where two wheels are toothed together the one that imparts the power is known as the driver, and the one receiving the power is called the follower.

FOOT WHEEL. In the selection of a foot wheel the workman must be governed by his own experience and taste, for, like cigars, the variety that exactly suits one person is very distasteful to another. Some workman prefer a treadle having a heel and toe motion, while others prefer a swing treadle like that shown in Fig. 135.

FOURTH WHEEL. The wheel that imparts motion to the escape pinion, the second hand being attached to the wheel.

FRICTION. The resistance which a moving body meets with from the surface of the body on which it moves; is caused by the unevenness

of the surfaces, combined with some other causes, such as natural attraction, magnetism, etc. It varies as does the weight or pressure applied and is independent of surfaces in contact, but if the surfaces are disproportionate to the pressure, rapid abrasion will be the result, which in its turn produces uneven surfaces and tends to increase the friction.

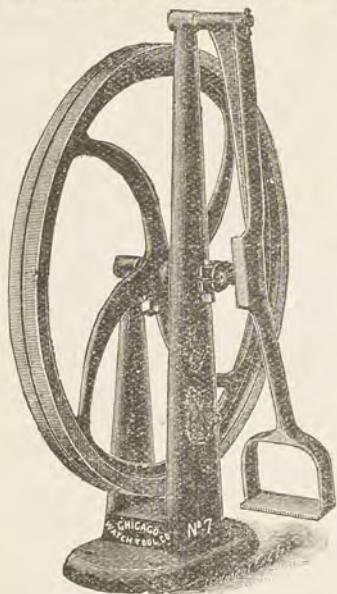

Fig. 135.

bodied or thin lubricant is desirable on small bearings, such as balance pivots, while as the barrel or power is approached and larger surfaces used the lubricant should be of a heavier body, or thicker. The nearer that a revolving surface is to its center of motion the less the friction. It is therefore essential where extra surface is desired that the surfaces be *increased in length*, and that the *diameter* of a pivot be *not increased* for if the *diameter* be doubled the resistance is doubled, as the acting surface is twice the distance from the center of motion.

FRictional ESCAPEMENTS. Those escapements in which the balance is never free or detached from the escapement. In contradistinction to the detached escapement. The duplex, cylinder or verge are examples of frictional escapements.

FRODSHAM, CHARLES. A skillful and successful watchmaker of London and the author of several valuable works on watchmaking. He was born in 1810 and died in 1871.

FROSTING. The matted or rough surface sometimes given to work before gilding or silvering. See *Electro Plating, Bronzing and Staining*. The gray surface produced on steel work of watches is also known as frosting, though more commonly called graying.

FULL PLATE. A term applied to movements having a full top plate and the balance above the plate.

FUZEE. A brass cone, as shown in Figure 136, having a spiral groove cut on it to hold the chain, and interposed between the barrel and center pinion of a watch for the purpose of equalizing the pull of the mainspring and converting it into a constant force. The pull of the mainspring is greater when wound around the barrel arbor than when it has expanded to the circumference

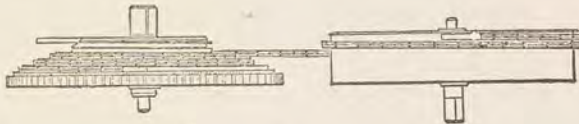

Fig. 136.

of the barrel. The principle of its construction is that by winding the fuze chain upon its cone the mainspring is wound, and the greatest pull comes upon the smaller end of the cone, and as the pull becomes less by the unwinding of the mainspring, the leverage (by means of the chain unwinding from a smaller to a larger cone) increases, and the rate of its increase constitutes a perfect adjustment of the mainspring. The fuze chain was first introduced by Gruet of Geneva in 1664. The fuze is held in great esteem by English watchmakers, and possesses many excellent points, although not employed in any American made watch.

Saunier says "The power of selecting the best series of turns to include within the limits of the stopwork is so important that it must be regarded as the reason for the retention of the fuze in chronometers; because with the fuze we can secure with certainty a rather longer period of going and a mainspring the uncoiling of which takes place under the best possible conditions. This last observation is of the highest importance, so much so that it alone should settle the discussion between the advocates of the fuze and of the going barrel. It explains why pocket chronometers, unless they have enormous barrels, cannot do without a fuze. It justifies the English makers, who in their splendid high-class watches, with such excellent rates, have retained it; but they make an error when they put it in watches of the commoner class." Glasgow says, "Considering the

great ease with which an ordinary marine chronometer mainspring with a fuzee can be perfectly adjusted, without any chance of resistance from adhesion or clustering, it seems strange that these men (referring to Jurgensen and Robert), who were so well acquainted with the superiority of the fuzee, should have devoted so much time to experiments with going barrel chronometers, and it is a question whether this persistence in trying to supercede the fuzee adjustment in marine chronometers has not lost this branch of the trade to France." Glasgow further says, "Notwithstanding the growing disposition amongst modern English watchmakers to praise and adopt that going barrel, all the old French watchmakers and writers on the subject agree as to the superiority of the fuzee and the tapered mainspring with a rigid attachment to the barrel."

GALILEO. A celebrated mathematician, born 1564, who discov-



Fig. 137.

ered the use of the pendulum. It is related that one morning he was in church and saw a lamp which was suspended by a

silken cord, from the ceiling, swinging to and fro after having been carelessly struck by one of the attendants. He noticed the regularity of the swing, comparing it with his pulse, and concluded that, by reason of its regularity, a simple pendulum might become a valuable agent in the measurement of time. In 1639, he published a treatise on the use of the pendulum in clocks, but there is no record of his having made one. The credit of actually putting a pendulum in a clock has been claimed for Richard Harris, of London, 1641; Vincent Galileo, son of the philosopher, 1649; and Huyghens, 1657. The weight of the evidence seems to be in favor of Huyghens as being the first to apply the Galilean theory in practice, but it is beyond dispute that the invention of the pendulum belongs to Galileo.

GAS HEATER. This heater, shown in Fig. 138, is to take the place of a forge in heating and tempering small articles. With a full pressure of gas, a piece of steel half an inch in diameter can be heated sufficiently to harden in about six minutes. It does not heat to a degree that will injure the quality of steel; which makes it very valuable for heating small pieces. Watchmakers will find in its use great convenience as well as economy of time and fuel; and also, that tools heated by it will be tougher than when heated in a forge in the usual way.

Put on sufficient gas to prevent the flame from descending into the tube. For heating larger pieces the flame should be nearly three inches wide. The upper ends of the curved side pieces should not be more than one-quarter of an inch apart. The article to be heated should be held in the upper part of the flame above the central blue part and parallel with it. The larger the piece to be heated the further it should extend into the flame. The heater should be located in a dark place, and supports may be provided for greater convenience in heating heavy articles.



Fig. 138.

GAUGE. An instrument for determining dimensions or capacity. The watchmaker cannot be too careful in the selection of his measuring instruments, as accuracy and perfection in watchmaking are essential elements to success. Accuracy is more essential than finish, though both are desirable; still a movement that is accurate may be a fine time-keeper, although it may be lacking in finish and not artistic to look upon. Measuring instruments of all kinds should be handled with care, and in the more delicate ones cleanliness also plays an important part. You cannot expect accurate results from a fine Vernier caliper that is recklessly thrown into a heap of other tools upon the bench. It should be carefully handled, and when you are through using it you

should carefully wipe it and place it in some drawer in your bench, where it will not be mutilated by being jammed against other tools.

Douzieme. A measuring tool having two limbs hinged together similar to a pair of scissors. One of the limbs terminates in a pointer that indicates upon a scale the extent to which the jaws are opened. The true Douzieme gauge has a scale divided into twelfths, though some patterns are now made that have a scale divided into tenths and hundreds of an inch, and again there are others that measure the fractions of a millimeter. This tool is useful for taking measurements of

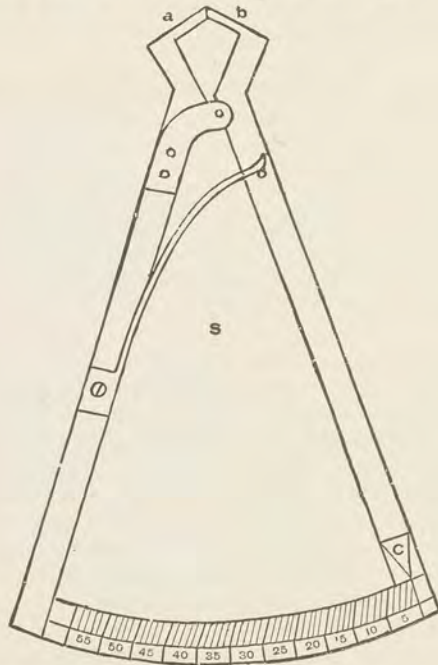

Fig. 139.

all kinds. For example, we will suppose that the watchmaker is putting in a new balance staff; we will take it for granted that the upper part of the staff is entirely finished and that he is ready to find the total length that the staff should be. He takes the top plate with the balance cock and potance attached, and measures the distance from the top of the cock hole jewel to top of potance hole jewel by means of this gauge. He places the jaw *a* on potance jewel and *b* on cock jewel, and notes the number on the scale that the pointer is opposite, which is generally 30 for an 18 inch size full plate American movement.

Micrometer Caliper. Fig. 140 is a full size cut of the Brown & Sharp Mfg. Co.'s micrometer caliper. It measures from one-thousandth of an inch to one-half inch. It is graduated to read to thousandths of an inch, but one-half and one-quarter thousandths are readily estimated. This instrument is also graduated to the hundredths of a millimeter, but when so graduated the table of decimal equivalents is omitted. They are also made to read to ten-thousandths of an inch. The edges of the measuring surfaces are not beveled, but are left square, as it is more convenient for measuring certain classes of work. It will gauge under a shoulder or measure a small projection on a plain surface.

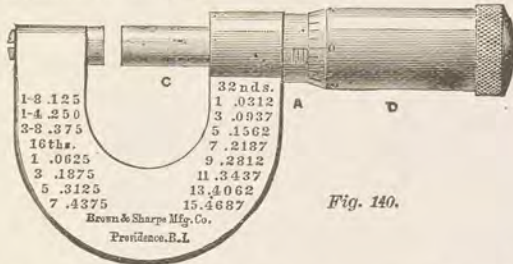

Fig. 140.

Watchmakers will especially appreciate micrometers of this form. This tool will be found very useful for gauging mainsprings, pinions, etc. In the caliper, shown by cut, the gauge or measuring screw is cut on the concealed part of the spindle C, and moves in the thread tapped in the hub A; the hollow sleeve or thimble D is attached to the spindle C and covers and protects the gauge screw. By turning the thimble, the screw is drawn back and the caliper opened.

The pitch of the screw is 40 to the inch. The graduation of the hub A, in a line parallel to the axis of the screw, is 40 to the inch, and is figured 0, 1, 2, etc., every fourth division. As the graduation conforms to the pitch of the screw, each division equals the longitudinal distance traversed by the screw in one complete rotation, and shows that the caliper has been opened 1-40th or .025 of an inch. The beveled edge of the thimble D is graduated into 25 parts, and figured every fifth division 0, 5, 10, 15, 20. Each division, when passing the line of graduation on hub A, indicates that the screw has made 1-25th of a turn, and the opening of the caliper increased 1-25th of 1-40th, or a thousandth of an inch.

Hence, to read the caliper, multiply the number of divisions visible on the scale of the hub by 25, and add the number of divisions on the scale of the thimble, from zero to the line coincident with the line of graduations on hub. For example: As the caliper is set in the cut, there are three whole divisions visible on the hub. Multiply this number by 25, and add the number of divisions registered on the scale of the thimble, which is 0 in this case, the result is seventy-five thousandths of an inch. ($3 \times 25 = 75 + 0 = 75$). These calculations are readily made mentally.

Differences between Wire Gauges in Decimal Parts of an Inch.

No. of Wire Gauge.	American or Brown & Sharpe.	Birmingham or Stubbs.	Washburn & Moen Manufacturing Co., Worcester, Mass.	Trenton Iron Co., Trenton, N. J.	New British.	Old English from Brass Mfrs. List.	No. of Wire.
000000	-----	---	.46	-----	----	-----	000000
00000	-----	---	.43	.45	-----	-----	00000
0000	.46	.454	.393	.4	.4	-----	0000
000	.40964	.425	.362	.36	.372	-----	000
00	.3648	.38	.331	.33	.348	-----	00
0	.32495	.34	.307	.305	.324	-----	0
1	.2893	.3	.283	.285	.3	-----	1
2	.25763	.284	.263	.265	.276	-----	2
3	.22942	.259	.244	.245	.252	-----	3
4	.20431	.238	.225	.225	.232	-----	4
5	.18194	.22	.207	.205	.212	-----	5
6	.16202	.203	.192	.19	.192	-----	6
7	.14428	.18	.177	.175	.176	-----	7
8	.12349	.165	.162	.16	.16	-----	8
9	.11443	.148	.148	.145	.144	-----	9
10	.10189	.134	.135	.13	.123	-----	10
11	.090742	.12	.12	.1175	.116	-----	11
12	.080808	.109	.105	.105	.104	-----	12
13	.071961	.095	.092	.0925	.092	-----	13
14	.064084	.083	.08	.08	.08	.083	14
15	.057068	.072	.072	.07	.072	.072	15
16	.05082	.065	.063	.061	.064	.065	16
17	.045257	.058	.054	.0525	.056	.058	17
18	.040303	.049	.047	.045	.048	.049	18
19	.03539	.042	.041	.039	.04	.04	19
20	.031961	.035	.035	.034	.036	.035	20
21	.028462	.032	.032	.03	.032	.0315	21
22	.025347	.028	.028	.27	.023	.0295	22
23	.022571	.025	.025	.024	.024	.027	23
24	.0201	.022	.023	.0215	.022	.025	24
25	.0179	.02	.02	.019	.02	.023	25
26	.01594	.019	.018	.018	.018	.0205	26
27	.014195	.016	.017	.017	.0164	.01875	27
28	.012641	.014	.016	.016	.0148	.0165	28
29	.011257	.013	.015	.015	.0136	.0155	29
30	.010025	.012	.014	.014	.0124	.01375	30
31	.008928	.01	.0135	.013	.0116	.01225	31
32	.00795	.009	.013	.012	.0108	.01125	32
33	.00708	.008	.011	.011	.01	.01025	33
34	.006304	.007	.01	.01	.0092	.0095	34
35	.005614	.005	.0095	.009	.0084	.009	35
36	.005	.004	.009	.008	.0076	.0075	36
37	.004453	---	.0085	.00725	.0068	.0065	37
38	.003965	---	.008	.0065	.006	.00575	38
39	.003531	---	.0075	.00575	.0052	.005	39
40	.003144	---	.007	.005	.0048	.0045	40

Pinion and Wire Gauge. The jewelers' gauge shown in Fig. 141, will be found very useful in measuring pinions, wire or flat metal. The

DECIMALS EQUALING PARTS OF AN INCH.

$\frac{1}{64} = .0156$	$\frac{11}{64} = .1718$
$\frac{2}{64} = .0312$	$\frac{12}{64} = .1875$
$\frac{3}{64} = .0468$	$\frac{13}{64} = .2031$
$\frac{4}{64} = .0625$	$\frac{14}{64} = .2187$
$\frac{5}{64} = .0781$	$\frac{15}{64} = .2343$
$\frac{6}{64} = .0937$	$\frac{16}{64} = .2500$
$\frac{7}{64} = .1093$	$\frac{17}{64} = .2656$
$\frac{8}{64} = .1250$	$\frac{18}{64} = .2812$
$\frac{9}{64} = .1406$	$\frac{19}{64} = .2968$
$\frac{10}{64} = .1562$	$\frac{20}{64} = .3125$

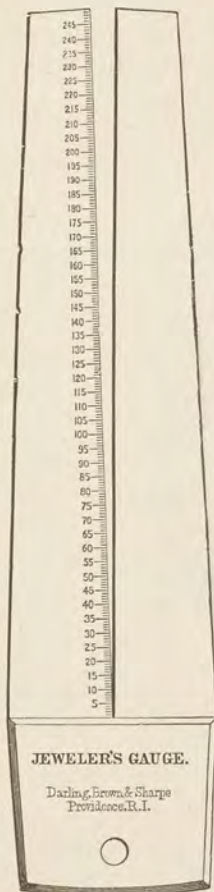

Fig. 141.

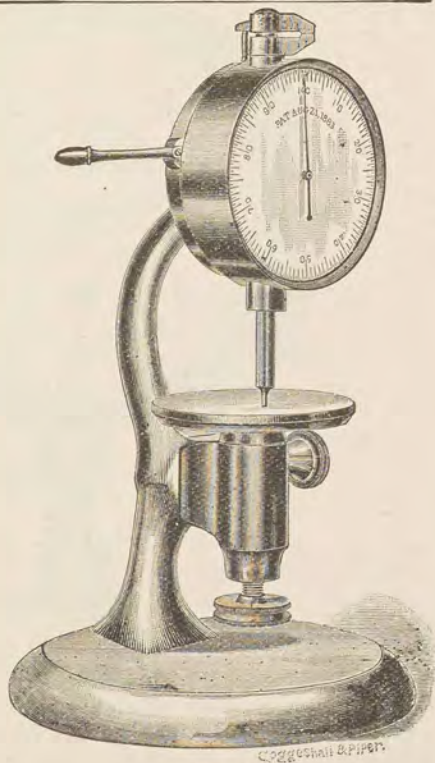

Fig. 142.

slot is graduated to thousandths of an inch. If in measuring a pinion it passes down the slot to number 70, then the pinion is $\frac{70}{1000}$ of an inch in diameter.

Registering Gauge. The registering gauges shown in the illustrations are two of the best examples of this class of tools. They are manufactured by A. J. Logan, Waltham, Mass., and are very accurate and nicely finished. Fig. 142 is an upright and jaw gauge, and Fig. 143 is designated as a jaw and depth gauge. They are both made to gauge one one-thousandth of a centimeter or one-thousandth of an inch.

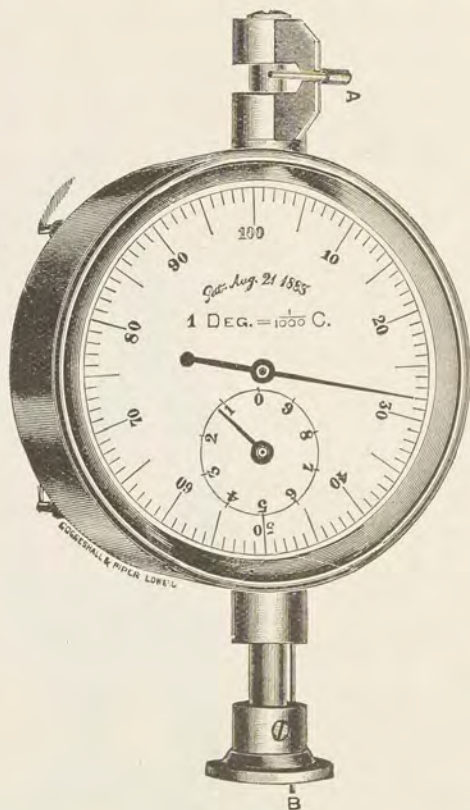

Fig. 143.

Fig. 143 shows the piece of work marked A, being gauged, while B represents a stationary spindle to get the depth of a hole or recess or the thickness of any piece of work which will be indicated on the dial.

Fig. 144 illustrates a millimeter gauge which is a favorite with the watchmaker. It will register to one-tenth of a millimeter, and is especially useful in getting the depth, width and thickness of main-spring barrels. This gauge, which was invented by Moritz Gross-

mann, was by him made with great care, but in late years it has been made by a German manufacturer of tools, who is not noted for extreme accuracy. This gauge has a millimeter scale on each side, and when the vernier slide is brought to the extreme end, as in meas-

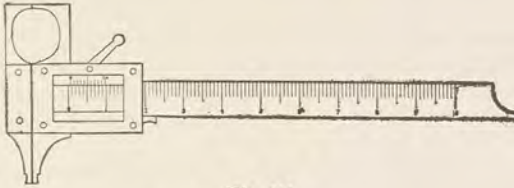

Fig. 144.

uring depths, it often happens that the zero marks cannot be made to correspond when the two ends are flush. To correct this, set the zero of the vernier slide to correspond with the zero on the large scale and then by means of a copper lap on the lathe and some carborundum powder, the two ends may be ground off at right angles and to coincide with one another. This gauge is hardly light enough for measuring pivots and balance staffs while working on them in the lathe. In fact there is no gauge as yet on the market which can be considered ideal for this purpose. A gauge for this purpose must be extremely light and at the same time must be very accurate.

Staff Gauge. The tool shown in Figs. 145 and 146, the invention of Mr. E. Beeton, is designed for measuring the height of the balance staff from the balance seat to the end of the top pivot. Fig. 146



Fig. 145.

is enlarged to give more distinctness.

$E E'$ is a piece of curved steel about $\frac{1}{20}$ of an inch thick, and $\frac{1}{16}$ of an inch wide. On the lower side of E' to the end the arm is filed down in width and thickness

to correspond to an ordinary balance arm; C is a slot in the upper arm E , which allows A, B, D, A' to be moved backward and forward. $D D'$ is a round brass post drilled and tapped, the part D' has a thread cut on it, and the part shown in the slot C fits with easy friction. B is a lock-nut, drilled and tapped to fit the thread on D' . It is for the purpose of clamping $D D'$ against the arm E . $A A'$ is a small steel screw with milled head, and is made to fit the tapped hole in $D D'$.

Mr. Beeton describes his method of using this tool as follows: Take your measurement of the distance *the balance seat is to be from end of the top pivot*, as follows: remove the end stone in balance cock, and

screw the cock on the top of the top plate, (18-size full plate movement) then taking the plate in your left hand, and tool (shown in Fig. 146) in your right, place *H* in position, so that the end of the screw *A'* rests on the jewel in the balance cock, and notice the position of the arm *E'* which corresponds to the balance arm, between the top plate and under side of balance cock. If the distance between the arm *E'* and end of screw *A'* is too great, the arm *E'* will be too low and touch the plate; if not enough, it will be too high and touch the regulator pins. Therefore, all that is necessary to do is to move the screw *A A'* up or down as the

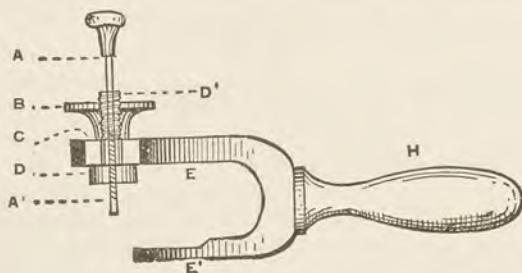

Fig. 146.

case may be, sufficiently to ensure that the arm *E'* will assume the position the *arm of the balance* is to have. Take an 18-size balance with oversprung hairspring, the arm is at the bottom of the rim; in that case, when measuring, the screw *A'* is adjusted so as to bring the arm *E'* close to the plate, when *A'* is resting on the balance jewel; if the balance is old style with undersprung hairspring, the balance arm is at top of rim, in which case *A'* is adjusted so that the arm *E'* is close to the balance cock; if the balance arm is in the center of the rim, as in some English and Swiss balances, the screw *A'* is adjusted so that the arm *E'* is midway between the plate and cock.

The reason the part *A, B, D, A'*, is arranged to move laterally in slot *C* is, because all balance shoulders are not the same distance from the center, and where, in some cases, the screw *A'* would be in a line with the center of the staff when the arm *E'* was resting on the balance seat, in other cases it would reach past the center, of course, short of it; and, therefore, it is made adjustable to suit all cases.

Staff Length Gauge. Another form of staff gauge, which is very simple, and which any watchmaker can manufacture is made as follows: Procure a small tube of steel, or make one from steel wire, thread it on the inside, and screw into each end a small steel plug as shown in Fig. 147, until the ends of the plug meet, cut off the outer end of plugs so as to leave the total length that of a short staff; harden, draw to a blue, place in a split chuck, plugs and all, and turn a pivot of good length on

each plug. Flatten the sides of the plugs at the base of the pivots, so that they may be readily turned in or out by the aid of tweezers. By inserting this tool in the place of the balance, and screwing the plugs to the right position, screwing bridge down, and adjusting until the right endshake is obtained, you can ascertain in a moment the exact length that the staff should be over all, which can easily be transferred to calipers and thence to the new staff.



Fig. 147.

Staff or Cylinder Height Gauge. The obvious advantage of this tool, which is shown at Fig. 148, is the automatic transfer of the measurement so that it may be readily applied to the work in hand. The tool, as the illustration shows, consists of a brass tube terminating in a cone-shaped piece. To the bottom of this cone is attached a disc through which a needle plays. Around the upper end of the tube is a collar upon which is fixed a curved steel index finger. A similar jaw, which is free to move, works in a slot in the tube. The movable jaw is tapped and is propelled by a screw that terminates in the needle point. This tool is very useful in making the necessary measurements required in putting in a staff. To use it in this work, set the pivots of the gauge through the foot hole, and upon the end-stone project the needle such a distance as you wish the shoulder to be formed above the point of the pivot. Next set the gauge in the foot hole as before, and elevate the disc to a height that shall be right for the roller, which is done by having the lever in place, the little disc showing exactly where the roller should come. Finish the staff up to that point; then take the next measurement from the end-stone to where the shoulder should be, for the balance to rest upon. This point being marked, the staff can be reversed and measurements commenced from the upper end-stone, by which to finish the upper end of the staff. Distances between the shoulders for pinions and arbors can be obtained with the same facility, a little practice being the only requisite.

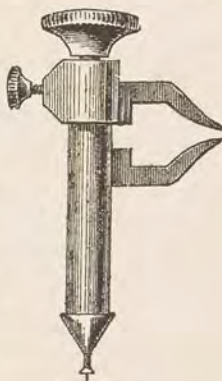

Fig. 148.

Twist Drill and Steel Wire Gauge. This gauge, which is shown in Fig. 149 will be found very useful in determining the diameter of twist drills and steel wire, and is very accurately and nicely made.

Vernier Caliper. Fig. 150 is an illustration of the Vernier Caliper, a light, convenient and valuable instrument for obtaining correct

measurements. The side represented in the illustration is graduated upon the bar to inches and fiftieths of an inch, and by the aid of a Vernier is read to the thousandths of an inch, (see description below). The opposite side is graduated to inches and sixty-fourths of an inch. The outside of the jaws are of suitable form for taking inside measurements, and when the jaws are closed, measure two hundred and fifty thousandths of an inch in diameter.

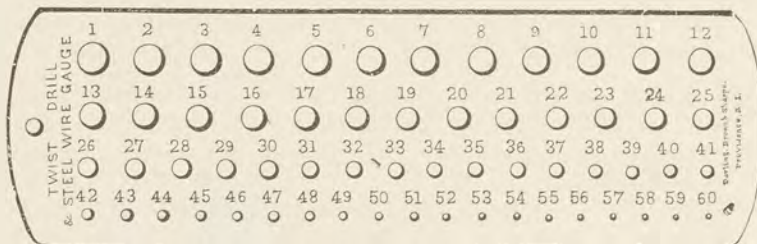

Fig. 149.

These instruments can be furnished with millimeters (in the place of sixty-fourths of an inch), and provided with a Vernier to read to one-fiftieth of a millimeter.

On the bar of the instrument is a line of inches numbered 1, 2, 3, each inch being divided into tenths, and each tenth into five parts, making fifty divisions to one inch. Upon the sliding jaw is a line of divisions, (called a Vernier, from the inventor's name), of twenty parts, figured 0, 5, 10, 15, 20. These twenty divisions on the Vernier correspond in

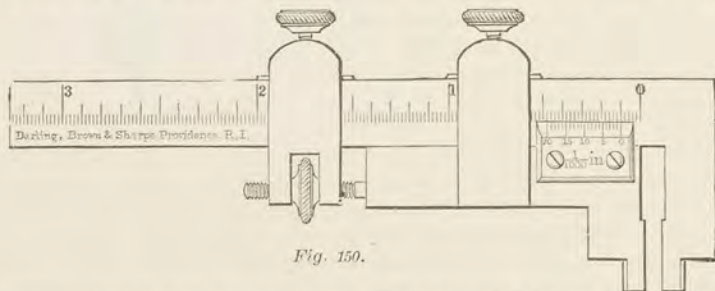

Fig. 150.

extreme length with nineteen parts, or nineteen-fiftieths on the bar, consequently each division on the Vernier is smaller than each division on the bar, by one-thousandth of an inch. If the sliding jaw of the caliper is pushed up to the other, so that the line 0 on the Vernier corresponds with 0 on the bar, then the next two lines to the left will differ from each other one-thousandth of an inch, and so the difference will continue to increase one-thousandth of an inch for each division till they again correspond on the twentieth line on the Vernier. To read the distance the

caliper may be open, commence by noticing how many inches, tenths and parts of tenths the zero point on the Vernier has been moved from the zero point on the bar. Then count upon the Vernier the number of divisions until one is found which coincides with one on the bar, which will be the number of thousandths to be added to the distance read off on the bar. The best way of expressing the value of the divisions on the bar is to call the tenths one hundred thousandths (.100) and the fifths of tenths, or fiftieths, twenty thousandths (.020). Referring to the accompanying cut it will be seen that the jaws are open one-tenth of an inch, which is equal to one hundred thousandths (.100). Suppose now, the sliding jaw was moved to the left, so that the first line on the Vernier would coincide with the next line on the bar, this would then make twenty thousandths (.020) more to be added to one hundred thousandths (.100), making the jaws then open one hundred and twenty thousandths (.120) of an inch. If but half the last described movement was made, the *tenth line on the Vernier* would coincide with a line on the bar, and would then read, one hundred and ten thousandths (.110) of an inch.

GERBERT. By some authorities accredited with the invention of the escapement and the application of the weight as a motive power for clocks. He was born in Belliac, in Auvergne, in 920 A. D. He was educated in a monastery, and served successively as Monk, Bishop, Archbishop and finally as Pope, being better known under the name of Sylvester II. He died May 12, 1003.

GILDING. (See *Electro-Plating*.)

GIMBALS. A contrivance for securing free motion and suspension of a ship's chronometer, compass, etc., so that it may not be affected by the motion of the ship. It is virtually a universal joint. It was invented by Cardan and first applied to timepieces by Huyghens.

GODDARD, LUTHER. One of the earliest manufacturers of American watches. In 1809 he opened a small shop in Shrewsbury, Mass., and commenced to manufacture watches of the verge pattern, as shown in Fig. 151, in somewhat larger quantities than had been attempted before. He could not compete in price, however, with the cheap foreign watches which were then being imported in large quantities, and accordingly he retired from the business in 1817, having manufactured about 500 watches. This was the greatest number of watches ever made by any one manufacturer in America up to this time.



Fig. 151.

GOING BARREL. A barrel having teeth around its circumference for driving the train. All American watches are of the going barrel type.

GOING FUSEE. A fusee having the maintaining power attachment. All modern fusees have a maintaining power which drives the train while the fusee is being wound. Examples of old fusees are, however, occasionally met with which have no maintaining power and the watch is stopped during the operation of winding.

GOLD ALLOYS. (See *Alloys*.)

To Distinguish Genuine from Spurious Gold. Genuine gold dissolves in chlorine water and the solution has only a slightly yellowish color. Hence chlorine is a safe agent to distinguish genuine from spurious gold. To test the genuineness of gilt articles, rub a tiny drop of mercury on one corner of the surface to be examined; it will produce a white, silvery spot if the gold is pure, or if there is gold in the alloy. If this silvery spot does not appear there is no gold in the surface exposed. To prove the correctness of this result a drop of the solution of nitrate of mercury can be dropped on the surface, when a white spot will appear if the gold is counterfeit, while the surface will remain unaltered if the gold is genuine. After the operation, heating the article slightly will volatilize the mercury and the spots will disappear. Pure gold can be distinguished from its alloys by a drop of chloride of gold or of nitrate of silver. If the gold is pure there will be no stain, but if mixed with other metals the chloride of gold will leave a brownish stain upon it and the nitrate of silver a gray stain. The simplest means of distinguishing genuine gold from a gold like alloy consists in running the article to be tested against an ordinary flint until a lustrous metallic coloring remains upon the latter. Now hold a strongly sulphurated burning match against the coloring; if it disappears from the flint the article is not gold.

GOLD SPRING. A very thin spring made of gold, attached to the detent of a chronometer escapement. See *Chronometer Escapement*.



George Graham.

GRAHAM, GEORGE. Born in Cumberland, England, in 1673 and died in 1751. He was buried in Westminster Abbey. He was the inventor of the mercurial pendulum (1715), the dead beat escapement for clocks, and is credited with being the inventor of the cylinder escapement.

GRAHAM ESCAPEMENT. An escapement invented by George Graham, in which the locking faces of the pallets are arcs of a circle concentric with the axis of the anchor, from which it gets the name dead-beat escapement, that is, the escape wheel tooth lies dead upon the locking face of the anchor and has no recoil or circular motion, except at the time it delivers an impulse. This form requires more care in making than the recoil. When applied to a seconds pendulum the escape wheel is made with thirty teeth, if a second hand is mounted. The anchor is made to cover from eight to ten teeth of the escape wheel. As the number of teeth covered by the anchor is decreased, correspondingly greater care is necessary in the making. Saunier says, "if this amount is exceeded the thickening of the oil has an appreciable influence, and, with a less amount, very accurate workmanship is necessary.

Laying Out the Escapement. Having decided upon the size of escape wheel and the number of teeth the anchor is to cover, draw a circle representing the escape wheel and divide it into thirty equal spaces, or whatever number of teeth the wheel is to have. If the wheel is to have thirty teeth, the space between two of them will be twelve degrees. The front faces of the teeth are to be drawn at an angle of ten degrees to a radial line. This inclination of the teeth is marked off by laying the base of the protractor so the center of it will coincide with the point of a tooth and mark off ten degrees from the radial line in the proper direction to form the faces of the teeth. Having located this ten degree point, join it with the point of the tooth by a straight line, continuing it past the center of the escape wheel, and from this center draw a circle to which the line forming the front face of the tooth is a tangent. The front faces of the other teeth may be drawn at the same angle as the first by simply drawing a straight line through the point of the tooth and tangential to the circle drawn last.

Draw a line from the center of the escape wheel through the point of a tooth, and to the right of this draw another line passing midway between the tenth and the eleventh teeth. From the points of these teeth erect perpendiculars, and where these cross will be the center of motion of the anchor. From the anchor center draw a straight line forming an angle of from one to two degrees to the right of the lines drawn from the points of the teeth. These lines will locate the lifting angle, the smaller amount being used in regulators and astronomical clocks. From the anchor center draw an arc passing through the points of the teeth which locates the opening of the pallets.

Now draw another smaller circle concentric with this one and at a distance equal to one-half the space between two teeth, less the drop, will give the thickness of the pallets. From the point of the tooth

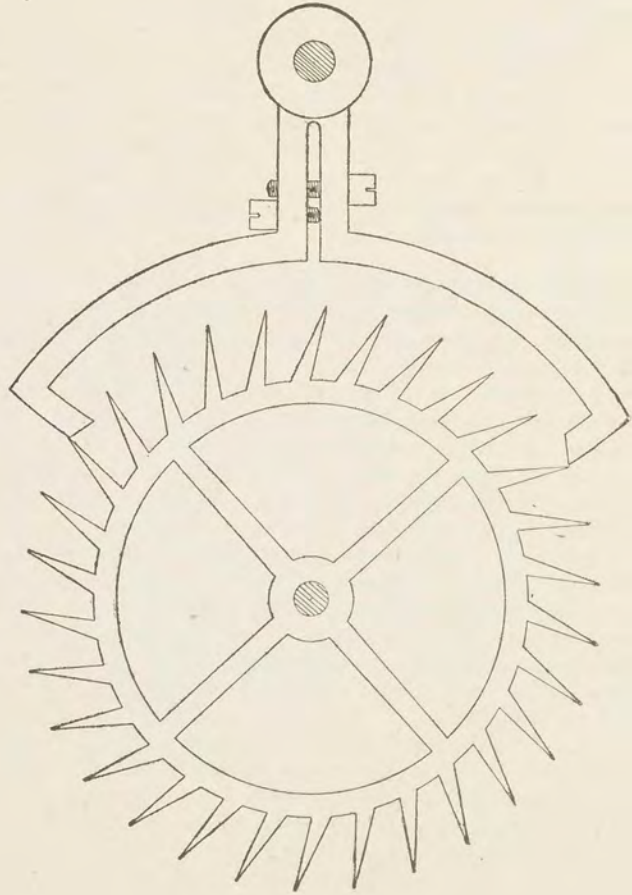

Fig. 153.

to where this last arc crosses the line of the lifting angle will be the impulse face of the pallet. All that remains to be done is to fill in the arm of the anchor. The form shown in Fig. 153 is very convenient, as slight inaccuraciēs in making may be corrected by means of the two adjusting screws.

Making the Anchor. This form of anchor presents no difficulties in making it, but, of course, more care is necessary than in an ordinary escapement. The points requiring the most care are the locking faces, which as before stated, must be circles concentric to the center of the anchor motion. A piece of good steel plate thoroughly annealed, is to be used to make the anchor from. This steel plate must be smoothed, and the angles of the anchor carefully outlined by using a sharp pointed marker. The surplus metal may be removed by drilling a number of holes or it may be sawed out by using a jewelers' saw. The steel plate should be thick enough that the impulse faces will at all times overlap the escape wheel teeth. For an astronomical clock or regulator it will be found of advantage to make the anchor as shown in Fig. 153, which will be found quite solid if the screws are as closely fitted as they should be. In hardening it will be quite sufficient if the pallets are hardened, as there is no wear except at these points, and there is of course no distortion to be corrected. The locking surfaces may be ground concentric by mounting the anchor upon an arbor which must be perfectly upright, which will fit the arbor hole with sideshake, but yet so it can be moved around. This arbor may be mounted in place of the T-rest of an American lathe, or what is better an attachment may be put on the the slide rest so that the anchor may be brought up to a good sized copper lap, to which carborundum is applied and by rotating the anchor upon this arbor, the locking surfaces may be ground off concentric. By using a zinc or tin lap with diamantine, the same method may be employed for polishing.

GRAVER. A steel cutting tool used for engraving, turning, etc. The "Guaranteed" gravers, shown in Fig. 154, are unique from the fact that they cut at both ends; the handle (which is patented) is so adapted that it will accommodate the reverse ends of innumerable sizes and shapes of gravers. The various angles of points of the gravers are very excellent and cover the entire field as used both for turning and engraving.

Use of the Graver.* Beginners should first practice on hard wood, then brass, iron, steel and hardened and tempered steel, progressing

*The directions apply to the use of the graver as a turning tool only. For directions for engraving on gold, silver, copper, etc., the reader is referred to two excellent works entitled, "General Letter Engraving" and "Modern Letter Engraving," Geo. K. Hazlitt & Co., Publishers, Chicago.

ing from one material to the other as his ability warrants. He should turn for a long time with the *point* of a square or lozenge-shaped graver, the end of which is ground off on a slope; this is the only possible method of learning to turn *true*, and it enables the workman to acquire

great delicacy of touch. Owing to carelessness, or to the fact that when first beginning they were set to work on metal that was too hard or rough, most beginners turn with gravers that are ground to very blunt points; as the graver bites less, they are obliged to apply a proportionately increased pressure, and only succeed in tearing the metal away, subjecting it to a kind of rolling action and rendering the hand heavy. If a pupil will not practice turning with the graver point so as to preserve it intact for some time, dependent on the nature of the metal, he will never be able to turn perfectly true. Irregular and sudden depressing of the graver point, or engaging it too deeply, causes its frequent rupture.† When sufficient experience has been gained in turning with the graver point and a trial is made with the cutting edge, do not attempt to take off much at a time by pressing heavily, but take the metal sideways, so as to remove a continuous thread, using all the points of the edge in succession. The metal will thus be removed as a thin ribbon or shaving. When the hand has had some experience, it will be found easy to remove long strips.

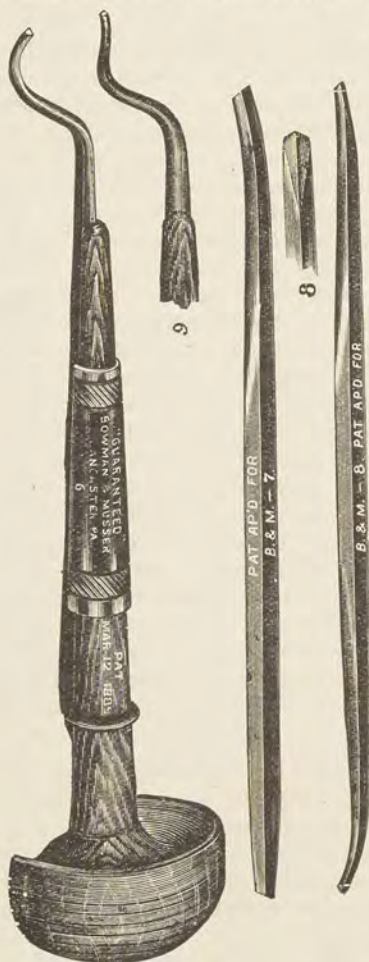

Fig. 154.

Hardened steel that has been drawn down to a blue temper requires certain precautions. If the graver is found not to cut cleanly, it must at once be sharpened, and no

† See illustrations and directions for holding graver, under heading *Making Balance Staff*.

attempt should be made to remove more metal by increasing the pressure of the hand, because the steel will burnish and become hard under a point or edge that is blunt, and the portions thus burnished are sometimes so hard as to resist the best gravers. The only way of attacking them is to begin at one side with a fine graver point, which must be sharpened frequently; at times it becomes necessary to temper the metal afresh before it will yield. It is well to moisten the point of the graver with turpentine.

Apprentices, and even watchmakers themselves, are frequently careless as to the proper sharpening of their gravers, and think they can hasten their work by application of considerable pressure; in this way they sometimes produce bright spots that require several hours' work before they can be removed. A majority of the Swiss workmen turn with the right or left hand indifferently. This is a very useful accomplishment, easily acquired when young.

GRAVIMETER. An instrument for ascertaining the specific gravity of liquid or solid bodies.

GRAVITY. The tendency which a body has towards the center of the earth.

Specific Gravity. The ratio of the weight of a body to the weight of an equal volume of some other body taken as the standard or unit. This standard is usually water for solids and liquids, and air for gases. Thus 19, the specific gravity of gold, signifies that gold is 19 times heavier than water.

GRAVITY CLOCK. This is a large glass clock dial, with a stud fixed in the center on which revolve two hands, as shown in Fig. 155, without any visible power to operate them. Hung in a jeweler's window so that it can be inspected from both sides without anyone discovering the source of power, it forms a great attraction to the curious and so becomes a durable and valuable advertisement. Take a plate of glass two feet square and lay out and gild a clock dial upon it, avoiding all ornament, in order to give the observer as little to see and as much to guess as is possible; cement, drill or otherwise fasten a stud in the center of the dial, projecting from the rear side so as to give facility for adjustment and certain exhibitions, which will be mentioned later. This stud must be perfectly hard and very finely polished in order to reduce the friction, which is considerable. The hands should be made of cedar, perfectly dry pine, or some other extremely light wood, left about a half inch thick, so that they can be nicely counterbalanced with lead, and will appear to the observer to be merely wooden hands. The circular discs at the inner extremities of the hands are hollowed out to receive two watch movements, and the boxes are closed with a cover fitting closely enough so

that it cannot be perceived by ordinary inspection. Each side of the hands is perfectly jeweled with large English fusee jewels, so as to revolve on the stud with as little friction as possible. The two watch movements must be regulated to run as closely together as possible and to keep exact time. Two half circles of lead are attached to the movements in such a way that their rotation in the hollow discs will change the center of gravity of the hands and so cause them to rotate on the stud of the dial. The lead half-circle for the minute hand is attached to the minute arbor of its movement and that of the hour hand to the hour pipe on its movement. If the wooden hands are nicely gilded it will add to the deception, as the disc for the movement may then be made of tin and be much smaller and more symmetrical. When finished, the clock is hung in the window, suspended by chains from holes bored in the corners. We will suppose that you have the clock finished and running nicely, and that the time shown is 2:20; take hold of the hands, bring them together and send them twirling around the dial; when they stop they will show the correct time, say 2:21. Suppose the hands show 9:45 or 2:45, bring both hands to 12 or 6 and they will immediately assume the correct position. Take off the minute hand and lay it on the bench for five or six minutes; put it on again, give it a twirl, and it will stop at the correct time. Various other tricks will suggest themselves for the astonishment and mystification of the jeweler's patrons, and considerable benefit can be derived from the curiosity of an excited town.

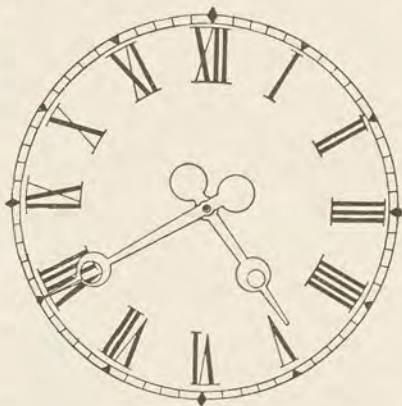

Fig. 155.

GRAVITY ESCAPEMENT. An escapement in which the train raises a lever a constant distance, and the weight of the lever when returning to position gives impulse to the pendulum. It is particularly applicable to turret clocks.

GREAT WHEEL. In the fusee it is the toothed wheel which transmits the power from the fusee to the center pinion. In the going barrel the toothed portion corresponds to the great wheel. In clocks without a barrel it is the wheel mounted upon the same arbor as the mainspring.

GRIGNION, THOMAS. A well-known watch and clockmaker, of London, who died in 1784. His son Thomas, also a clockmaker, claimed

for him the honor of bringing to perfection the horizontal principle in watches and the dead beat in clocks.

GROSSMANN, MORITZ. A celebrated horologist, author and linguist. Though born and raised in Saxony, he was very conversant with the French, Italian and English languages, and contributed to many technical journals throughout the world. He was a member of the



Moritz Grossman.

British Horological Institute, the Galileo Galilei, Milan, Italy, and the Polytechnic Society of Leipzig. It was while in the hall of the latter society, and just after delivering a lecture on horology, that he was stricken with apoplexy, which resulted in his death Jan. 23, 1885. He received his training as a watchmaker under the best masters of Saxony, Switzerland, France and England. He located in Glashutte, Saxony, in 1854, and began the manufacture of fine watches, tools and metric gauges, and later on large sized models of the various escapements. His first essay, "The Detached Lever Escapement," was written in 1864 and was awarded first prize by the British Horological Institute. In 1869 he took the first prize offered by the Chambre de Commerce, Geneva, on the subject of "The Construction of a Simple and Mechanically Perfect Watch." In 1878 he published a translation of Claudius Saunier's "Modern Horology."

GUARD PIN. See *Safety Pin.*

GYRATE. To revolve around a central point: See *Center of Gyration.*

HAIR SPRING. The spring that determines the time of vibrations of the balance. The term hair spring is distinctively American, as all other nations use the more fitting appellation of Balance Spring. The hair spring was invented by Dr. Robert Hooke in 1658, and first applied to a double balance watch for Charles II., on which was inscribed "Robt. Hooke, Inven: 1658. T. Tompion, fecit, 1675." The spring was nearly straight. In 1660 Dr. Hooke altered the form by making it spiral. The different forms of hair springs are illustrated in Fig. 157. The most common form is the volute or spiral spring, shown at A. B is a helical spring used in chronometers. C is a Breguet spring, which is a flat spiral with its outer end bent up above the plane of the body of the spring, and carried in a long curve towards the center, near which it is fixed. The advantage of the Breguet spring is that it distends when in action, on each side of the center, thus relieving the balance pivots of the side pressure which the ordinary flat spring tends to give, and it also

offers opportunities of obtaining isochronism by varying the character of the curve. Glasgow says that a hair spring, of whatever form, to be isochronous must satisfy the following conditions: its center of gravity must always be on the axis of the balance, and it must expand and contract in the vibrations concentrically with that axis. Immish contends that mere length of spring has nothing to do with isochronism. Mr. Glasgow contends that the whole question of isochronism resolves itself into the adoption of a spring of the correct length, and recommends for a lever watch fourteen turns if a flat, and twenty turns if a Breguet spring is used, if a cylinder watch use from eight to twelve turns. He argues that if a spring is too short, the short vibrations will be fast and

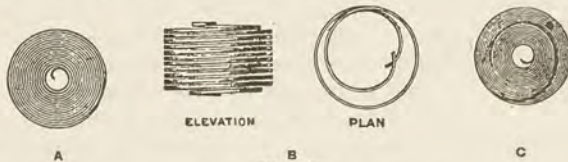

Fig. 157.

the long vibrations slow, and that all bending and manipulation of the spring with a view to obtaining isochronism are really only attempts to alter the effective length of the spring. Mr. Britten contends that the position of the points of attachment of the inner and outer turns of a hair spring in relation to each other has an effect on the long and short vibrations quite apart from its length. For instance, a very different performance may be obtained with two springs of precisely the same length and character in other respects, but pinned in so that one has exactly complete turns, and the other a little under or a little over complete turns. He argues that a short spring as a rule requires to be pinned in short or complete turns, and a long one beyond the complete turns.

In duplex and other watches with frictional escapements, small arcs of vibration and short springs, it will be found that the spring requires to be pinned in nearly half a turn short of complete turns.



Fig. 158.

when a movement is in beat. Place the lower part of balance staff in round cleat A. Turn balance until ruby pin comes over oblong hole at

HAIR SPRING STUD INDEX.

Wathier's Self-adjusting Hair Spring Stud Index, shown in Fig. 158, is a very useful device, and by its use the watchmaker can save much time and can obtain better results than by following the regular methods of determining

B. Now let the balance down until roller table rests on steel center plate. The balance will then be ready for the spring. Place the hair spring on the staff, with the stud in exact line with the line on the index corresponding in name with the movement you wish to put in beat. Now fasten the hair spring collet on the staff, and you will find movement in beat. At a glance, the watchmaker may be lead to believe that this tool is only applicable to the fourteen movements shown on the index, but in reality it serves for almost every movement that comes into the hands of the repairer. For example, the line marked E. Howard & Co., not only serves for that make of watches, but also for Waltham 14 and 16 sizes. Directions accompany each tool.

Fig. 159 shows a hair spring stud index recently placed on the market by A. W. Johanson. The engraving shows the full size of the tool,

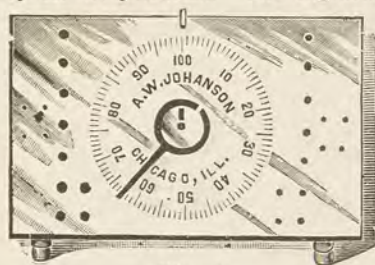

Fig. 159.

which consists of a steel plate mounted on feet, and pierced with a number of holes for the reception of screws, when taking down a watch. In the center of the index is a hole for the staff, and an oblong slot for the reception of the roller jewel. To get any American movement in beat proceed as follows: In front of No. 100 is a small spring, push same

towards No. 10, then place the balance on top of the stand, with staff in center and roller jewel in the oblong hole, let the spring back gently, the balance will then take its own position. Set degree hand in front of the desired degree, as per directions on index table, place hair spring stud in front of degree hand, and push on the collet.

INDEX TABLE FOR HAIR SPRING STUDS.

Size.	Degree.	Size.	Degree.
Columbus...18	Open Face Breguet...23	Hampden...16	
Columbus... 6	Open Face Breguet..	Hampden... 6	Hunting.....50
Elgin...18	Open Face Breguet...66	Howard...18	Old Model..... 5
Elgin...16	Open Face Breguet...52	Howard...18	New Model.....23
Elgin...16	Flat Hair Spring...52	Howard...16	
Elgin...10	Flat Hair Spring...50	Howard... 6	
Elgin... 6 and 8	Flat Hair Spring...50	Rockford...1827
Elgin... 0	Flat Hair Spring...	Rockford... 6	
Illinois...18	Open Face Breguet...33	Waltham...18	Key Flat Hair Spr'g...48
Illinois...18	Hunting.....84	Waltham...18	O. F. Hair Spring...61
Illinois...18	Open Face Flat...89	Waltham...18	Breguet.....50
Illinois...16		Waltham...14-1642
Illinois... 6	Hunting.....52	Waltham... 4- 650
Illinois... 4		Waltham... 142
Hampden...18	Dueber Hunting...80	Seth Thomas 18	Open Face.....50
Hampden...18	Open Face.....75	Seth Thomas 18	Hunting.....52

HALF PLATE. A half-plate watch, as its name implies, is one in which the top-plate covers half of the pillar or lower plate, and which supports the upper ends of the barrel arbor, center and third pinions.

HALL MARK. The stamp placed upon articles of gold and silver after being assayed by government officials. The United States government does not employ hall marks, but articles can be assayed by the proper officers, and a certificate of their standard given upon payment of a small fee. The hall marking of watch-cases is not compulsory in Switzerland, unless they contain some stamp indicating their quality, and the English and other hall marks are recognized. In Great Britain, with few exceptions, the hall marking of jewelry is optional with the manufacturer, but all gold or silver cases made in Great Britain or Ireland must be marked. The hall marks for Switzerland are shown in



Fig. 160. Hall marks are not alone useful for determining the quality of goods, but are also a great aid in determining the age of watches, etc. The hall mark of Great Britain consists of several impressions in separate frames or shields; the quality mark, the office mark (which designates where it was stamped), year mark, and if duty is chargeable, the head of the reigning sovereign. The standard or quality mark for London and Birmingham is, for gold, a crown, as shown in Fig. 161, and 18 or some other figure to designate the carat. The standard mark for 22 carat



Fig. 161.

gold prior to 1845 was a lion passant, which is now used as the quality mark for sterling silver. The quality mark for 15k. gold is 15 or .625, for 12k. is 12 or .5 and for 9k. is 9 or .375. The decimals indicate the proportions of pure gold of 24k. in the alloys. The office or location mark for London is a Leopard's head in a shield, as shown in Fig. 161. The leopard's head was crowned prior to 1823. Watch cases have been exempt from duty in Great Britain since 1798, but all foreign cases are stamped, the die for silver being an octagon with the word foreign and for gold a cross. These dies also contain a mark to show where marked, that of London having a sun or full moon.

1796-7	1877-8	1878-9	1879-0	1880-1	1881-2	1882-3	1883-4	1884-5	1885-6	1886-7	1887-8	1888-9	1890-0	1890-1	1891-2	1892-3	1893-4	1894-5	1895-6
A	B	C	D	E	F	G	H	I	K	L	M	N	O	P	Q	R	S	T	U
1796-7	1816-7	1817-8	1818-9	1819-0	1820-1	1821-2	1822-3	1823-4	1824-5	1825-6	1826-7	1827-8	1828-9	1829-0	1830-1	1831-2	1832-3	1833-4	1834-5
a	b	c	d	e	f	g	h	i	k	l	m	n	o	p	q	r	s	t	u
1796-7	1836-7	1837-8	1838-9	1839-0	1840-1	1841-2	1842-3	1843-4	1844-5	1845-6	1846-7	1847-8	1848-9	1849-0	1850-1	1851-2	1852-3	1853-4	1854-5
A	B	C	D	E	F	G	H	I	K	L	M	N	O	P	Q	R	S	T	U
1796-7	1856-7	1857-8	1858-9	1859-0	1860-1	1861-2	1862-3	1863-4	1864-5	1865-6	1866-7	1867-8	1868-9	1869-0	1870-1	1871-2	1872-3	1873-4	1874-5
a	b	c	d	e	f	g	h	i	k	l	m	n	o	p	q	r	s	t	u
1796-7	1876-7	1877-8	1878-9	1879-0	1880-1	1881-2	1882-3	1883-4	1884-5	1885-6	1886-7	1887-8	1888-9	1889-0	1890-1	1891-2	1892-3	1893-4	1894-5
A	B	C	D	E	F	G	H	I	K	L	M	N	O	P	Q	R	S	T	U
1796-7	1896-7	1897-8	1898-9	1899-0	1900-1	1901-2	1902-3	1903-4	1904-5	1905-6	1906-7	1907-8	1908-9	1909-0	1910-1	1911-2	1912-3	1913-4	1914-5
a	b	c	d	e	f	g	h	i	k	l	m	n	o	p	q	r	s	t	u
1796-7	1916-7	1917-8	1918-9	1919-0	1920-1	1921-2	1922-3	1923-4	1924-5	1925-6	1926-7	1927-8	1928-9	1929-0	1930-1	1931-2	1932-3	1933-4	1934-5
A	B	C	D	E	F	G	H	I	K	L	M	N	O	P	Q	R	S	T	U
1796-7	1936-7	1937-8	1938-9	1939-0	1940-1	1941-2	1942-3	1943-4	1944-5	1945-6	1946-7	1947-8	1948-9	1949-0	1950-1	1951-2	1952-3	1953-4	1954-5
a	b	c	d	e	f	g	h	i	k	l	m	n	o	p	q	r	s	t	u
1796-7	1956-7	1957-8	1958-9	1959-0	1960-1	1961-2	1962-3	1963-4	1964-5	1965-6	1966-7	1967-8	1968-9	1969-0	1970-1	1971-2	1972-3	1973-4	1974-5
A	B	C	D	E	F	G	H	I	K	L	M	N	O	P	Q	R	S	T	U

Fig. 162.

In Great Britain, from 1697 to 1823, the standard mark for silver was a Lion's head, and the office mark a figure of Britannia, but from the latter date to the present time, a lion passant and a leopard's head have been used. The date marks shown in Fig. 162, will prove very valuable in fixing the dates of watches made in Great Britain as in most cases, the case was made at a date coinciding pretty closely with the manufacture of the watch.

HAND. An index or pointer used in indicating minutes and hours on a watch, clock or similar dial.

HAND REMOVER. The style of watch hand remover shown in Fig. 163 is a very nice pattern and can also be used as a roller remover and for several other purposes.



Fig. 163.

The action of the tool can be readily understood by examining the illustration. The threaded wire in the center extends through the entire tool and is raised or lowered by the milled nut at the end of the handle. This tool can also be used for holding hands while broaching the hole, or the tool shown in Fig. 164, and known as the nine-hole sliding tongs, and many



Fig. 164.

other patterns, for sale by material dealers, may be used for the same purpose. Fig. 165 shows a second hand holder, with the hand in position ready to broach. This tool can also be used as a screw head tool. In order to broach out a new hand, if the boss of the old hand has been preserved, place a small

slip of cork upon the end of the broach and insert it in the old hand



Fig. 165.

as far as it will go, and the new hand may then be broached until the cork is reached before trying it for a fit. The holes in the hands may be closed by forcing them into a conical hole in a steel plate, first turning off the metal around the edge of the hole, so that it is left rather thin, or it may be contracted after reducing the edge, by means of the stake.

HARRIS, RICHARD. A clockmaker of London. Comparatively little is known of this clockmaker, except that a friend of his, one Thomas Grignon, authorized his son to make known that Richard Harris was the person who first applied a pendulum to a clock, eight years before Vincent Galileo laid claim to having made a clock regulated by a

pendulum. There is no evidence, however, to prove that Harris was the inventor of the pendulum.

HARRISON, JOHN. This celebrated horologist was born at Faulby, Yorkshire, England, in 1693. In 1700 the family moved to Barrow, in Lincolnshire, where he carried on the business of repairing watches and clocks. In 1735 he went to London with a timekeeper of his own invention and construction, and through the interest taken in him by Graham and Halley, he was allowed, in 1736, to take it on board a king's ship to Lisbon. In 1761 he made another chronometer which was thought sufficiently correct to enable him to claim the government reward offered in 1714. The government offered £20,000 to anyone who would make a chronometer



that would determine the longitude to within half a degree. He received the reward in 1767. He is credited with being the inventor of the going fusee and the gridiron pendulum. He died in 1776.

HAUTEFEUILLE, JOHN. An ingenious mechanic born at Orleans in 1764. He was the first person to apply a small steel spring to regulate the vibrations of the balance. Huygnens applied for a patent on the invention, but was refused, on the ground that Hautefeuille had laid his invention before the Academy of Sciences in 1694, some years before. In 1722 he invented what was known as the rack lever escapement.

HENLEIN, PETER. A clockmaker of Nuremberg, to whom some authorities give the credit of the invention of the pocket watch. It is claimed that he made pocket watches or clocks, soon after the year 1500. He was born in 1480, and died in 1542.

HOOKE, ROBERT. He was born at Freshwater, Isle of Wight, on the 18th of July, 1635. In 1658 he invented the hairspring and applied it to a watch for Bishop Wilkins in 1661. About the same time he invented the circular or conical pendulum, which was in 1663 shown in the Royal Society. In 1664 the Royal Society gave him an annuity of £30 for his work as director of experiments. He invented anchor pallets in 1666. In 1655 he invented a wheel cutting engine and rounding-up tool for watch and clockmakers. He was also the inventor of the hydrometer and leveling instrument, and the author of the axiom on the compression and extension of springs and other elastic bodies "as the tension is so is the force." In 1677 he was elected Honorary Secretary of the Royal Society. He died March 3, 1702, and was buried in St. Helen's church, London.

HORIZONTAL ESCAPEMENT. (*See Cylinder Escapement.*)

HOROLOGICAL BOOKS. The following list of books published on horology and kindred subjects from 1639 to 1850 inclusive, may prove of value to those who have a horological library or who contemplate such a step. Works on horology have become so numerous since 1850 that the space at command will not admit of their mention.

L'usage du Cadran ou de l'Horloge Physique universel. Galileo, Paris, 1639.

Nuova Scienza di Horologi a Polvere. Angelo Maria P. Radi, 4to, Rome, 1665.

Instructions concerning the use of Pendulum Watches for finding the Longitude at Sea. Christian Huyghens, Phil. Trans., London, 1669.

Horologium Oscillatorium, sive de motu pendulorum ad Horologia aptato. F. Muguët, Paris, 1673.

Horologium Oscillatorium, sive de motu Pendulorum. Christian Huyghens, Paris, 1673.

Factum touchant les Pendules des Cloches. John Hautefeuille, 4to, Paris, 1675.

Horological Dialogues in three parts, shewing the nature, use and right managing of Clocks and Watches. John Smith, London, 1675. This was, beyond doubt, the first work on horology printed in the English language.

On Portable Watches. Godfrey William de Leibnitz, Phil. Trans., London, 1675.

A new invention of a Clock descending on an Inclined Plane. M. de Gennes, Phil. Trans., London, 1678.

Concerning a movement that measures Time after a peculiar manner; being a Clock descendant on an Inclined Plane. Rev. Maurice Wheeler, M. A., Phil. Trans., London, 1684.

Horological Disquisitions concerning the Nature of Time, etc. John Smith, 12mo, London, 1694. A second edition, London, 1708.

The Artificial Clockmaker. Wm. Derham, D. D., F. R. S., 8vo, London, 1696. A second edition, 1700. Fourth edition, with large emendations, 12mo, London, 1734. New edition, 12mo, London, 1759.

The antiquity of Clockwork. Wm. Durham, London, 1700.

Philosophical Experiments and observations of Dr. Robert Hooke, F. R. S., Wm. Derham, London, 1700.

Balance Magnetique. John Hautefeuille, 4to, Paris, 1702.

Reasons of the English Clock and Watchmakers against the Bill to Confirm the pretended new Invention of using precious and common Stones about Watches, Clocks and other Engines. London, 1704.

Règle Artificielle du Temps, Henry Sully. Paris, 1717. A second edition 1717, with additions by Julien LeRoy.

Description abrégée d'une Horloge d'une nouvelle construction, pour la juste mesure du Temps sur mer. Henry Sully, Paris, 1726.

A contrivance to avoid the Irregularities in a Clock's Motion, occasioned by the action of Heat and Cold on the Pendulum Rod. Phil. Trans., London, 1726.

Letter asserting his right to the Curious and Useful Invention of making Clocks to keep time with the Sun's Apparent Motion. Joseph Williamson, Phil. Trans., London, 1726.

Observations on the Going of a Clock in Jamaica. Colin Campbell, Phil. Trans., London, 1734.

Traité Général des Horloges, Jacques Alexandre (R. P. Dom), Paris, 1734.

Experiments on the Vibrations of Pendulums. Wm. Durham, D. D., F. R. S., Phil. Trans., London, 1736.

Traité d'Horlogerie. M. Thiout, 2 vols., Paris, 1741.

Of the True Inventor of the Contrivances in the Pendulum of a Clock to Prevent Irregularities of its motion from Heat or Cold. James Short, F. R. S., Phil. Trans. London, 1751.

Description of two methods by which the Irregularities in the motion of a clock, arising from the influences of heat or cold on the Pendulum, may be prevented. John Ellicott, London, 1753.

Account of the Influence of two Pendulum Clocks on each other. John Ellicott, 4to, London. No date. 1754?

Traité d'Horlogerie. J. E. Lepaute, Paris, 1755.

L'Art des Conduire et de Regler les Pendules et les Montres. F. Berthoud, Paris, 1760.

Concerning the going of Mr. Ellicott's clock at St. Helena. Jas. Short F. R. S., Phil. Trans., London, 1762.

Observations on a clock of Mr. John Shelton, made at St Helena. Nevil Maskelyne, Phil. Trans., London, 1762.

Mechanicus and Flaveus; or the Watch Spiritualized. 8vo, London, 1763.

Les Quatres Parties du Jour. Charles Francis de Saint-Lambert
Paris, 1764.

Etudes Chronometriques. Pierre Le Roy, Paris, 1764.

Account of the Proceedings in order to the Discovery of the Longitude at Sea, subsequent to those published in the year 1763. John Harrison, 8vo, London, 1765.

Supplément à l'Essai sur l' Horlogerie. F. Berthoud, Paris, 1765.

Thoughts on the Means of Improving Watches, and particularly those for use at sea. Thos. Mudge, Jr., London, 1765.

Elements of Clock and Watch Work adapted to practice. Alexander Cumming, 4to, London, 1766.

Remarks on a Pamphlet lately published by Dr. Maskelyne. John Harrison, 8vo, London, 1767.

The Principles of Mr. Harrison's Timekeeper; with plates of the same on India Paper, Published by order of the Commissioners of Longitude. 4to, London, 1767.

The Mensuration of Time. John Harrison, London, 1767.

An account of the going of Mr. Harrison's Watch, at the Royal Observatory, from 6th May, 1766, to March 4th, 1767, with the original observations and calculations of the same. Nevil Maskelyne, D. D., F. R. S., 4to, London, 1768.

Memoirs for the Clock-makers of Paris, ent Etrennes Chronometriques. Treatise on the Labours of Harrison and Le Roy for the discovery of the Longitude at Sea, and of the proofs made of their works. English translation from the French of Peter Roy, 4to, London, 1768.

Select Mechanical Exercises, showing how to construct different Clocks, Orreries and Sun dials on plain and easy principles. James Ferguson, F. R. S., 8vo, London, 1773.

Traité des Horloges Marine. F. Berthoud, 4to, Paris, 1773.

An Introduction to the Mechanical part of Watch and Clock Work, Illustrated with 18 copper plates. Thomas Hatton, 8vo, London, 1774.

Les Longitudes par la Mesure du Temps. F. Berthoud, 4to, Paris, 1775.

Eclaircissements sur l'Invention des Nouvelles Machines proposées pour la détermination des Longitudes en Mer, par la mesure du temps. F. Berthoud, 4to, Paris, 1775.

Clock work and Music. John Harrison, 8vo, London, 1775.

A letter from Mr. Christian Meyer, Astronomer to the Elector Palatine, to Mr. N. N., on the going of a New Pendulum Clock, made by Mr. John Arnold, and set up in the Elector's Observatory, at Manheim. From the German, 4to, London, 1781.

La Mesure du Temps Appliquée à la Navigation. F. Berthoud, 4to, Paris, 1783.

Essai sur l'Horlogerie. F. Berthoud, 2 vols., 4to, 1763. Reprinted 1786.

De la Mesure du Temps. F. Berthoud, 4to, Paris, 1787.

Narrative of Facts Relating to some Timekeepers Constructed by Thos. Mudge. Thos. Mudge, Jun., London, 1792.

Answer to a pamphlet, entitled, A Narrative of Facts, lately published by T. Mudge, Jun., relating to some timekeepers constructed by his father, Mr. Thos. Mudge. Nevil Maskelyne, 8vo, London, 1792.

Investigations, founded on the theory of Motion, for determinating the Times of Vibrations of Watch Ballances. George Atwood, Phil. Trans., London, 1794.

Histoire de la Mesure du Temps par les Horologes. F. Berthoud, 2 vols., 4to, Paris, 1802.

Pocket Watches. —Parr, London, 1804.

Essai sur l'Histoire abrégée de l' Horlogerie. M. Perron, Paris, 1820.

Account of Experiments to determine the Figure of the Earth by means of the Pendulum vibrating seconds in different Latitudes; as well as on other subjects of Philosophical Inquiry. Captain Sabine, 4to, London, 1825.

An Appeal. Thos. Earnshaw, 8vo, London, 1836.

Historical Treatise on Horology. —Henderson, 8vo, London, 1836.

Results of Experiments on the Vibration of Pendulums with different Suspending Springs. J. W. Frodsham, 4to, London, 1839.

A Treatise on the Management of Public Clocks, etc., Francis Abbot, London. No date. About 1840. Three editions.

Eiffe's Improvements in Chronometers and Molyneux's Specification of Patent for Improvement in Chronometers. 4to, London, 1842.

On the Construction and Management of Chronometers. E. J. Dent, 8vo, London, 1842.

Traité d'Horlogerie. Louis Moinet, Paris, 1843.

Railroad Clocks. B L Vulliamy. 8vo, London, 1845.

Treatise on Clock and Watch Making, Theoretical and Practical. Thomas Reid. 8vo, Edinburgh, 1826. Reprint, Philadelphia, 1832. Reprint, London, 1847.

Time and Time Keepers. Adam Thompson, 12mo., London, 1847.

Clock and Watchmaking. E. B. Denison, M. A., 12mo, London, 1848.

HOURLASS. An instrument for measuring the hours, consisting of a glass vessel having two cone-shaped compartments, from the uppermost of which a quantity of sand, water, or mercury occupies an hour in running through a small aperture into the lower.

HOURL WHEEL. The wheel which turns on the cannon pinion and carries the hour hand.

HOURIET, F. A noted Swiss watchmaker of the eighteenth century. He worked for nine years in Paris with such men as F. Berthoud, Romilly and Le Roy. He afterwards returned to Neufchatel, and much of the rapid progress made by the watchmakers of that canton was credited to his efforts.

HOWARD, EDWARD. The veteran watch- and clockmaker of Boston. He was born in Hingham, Mass., Oct. 6, 1813. He served an apprenticeship of seven years as a clockmaker. At the age of twenty-nine he embarked in the business of clockmaking on his own account, his partner being D. P. Davis, and the firm being known as Howard & Davis. The firm manufactured a very superior line of clocks and regulators, and their goods soon gained a world-wide reputation. In 1849 Mr. Howard, together with A. L. Dennison, Samuel Curtis, a Boston capitalist, and D. P. Davis organized a company for the manufacture of watches. This company was separate and distinct from that of Howard & Davis, and was known as the American Horologe Company. This company was the first in the world to undertake the manufacture of watches on the interchangeable system. The first watches were made to



Edward Howard.

run eight days and had two barrels. They proved a failure, however, and were soon abandoned. The factory was situated directly opposite to the Howard & Davis shop. The name of the company was changed subsequently to the Warren Manufacturing Company, and later to the Boston Watch Company. In 1854 the location of the factory was changed to Waltham. In 1857 the company made an assignment, and

the property, consisting of real estate, the factory, and numerous other buildings, machinery, steam engine, etc., was offered at public auction and was bid in for \$56,500 by Royal E. Robbins, for himself and the firm of Tracy & Baker, case makers of Philadelphia, who were creditors of the defunct company. After the failure of the Boston Watch Company, Mr. Howard returned to Roxbury and continued with his clock business in connection with Mr. Davis. In 1858 he again began manufacturing watches in the old factory of the Boston Company, in Roxbury, and placed on the market the first quick train movements ever made

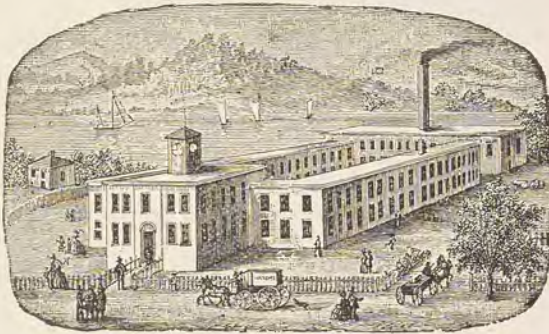

Factory of Boston Watch Co., 1857.

in this country. Even in those early days of American watchmaking, the Howard watches were noted for their superior qualities as time keepers, a reputation which followed them up to the present time. In 1861 the Howard Clock and Watch Company was organized with a capital of \$120,000. In 1863 the name was changed to the Howard Watch and Clock Company and in 1881 it was again changed to the E. Howard Watch and Clock Company. In 1882 Mr. Howard severed his connection with the watch company and retired from all active business. Mr. Howard invented many labor saving devices in the horological line, among which may be mentioned the swing rest.

HUYGHENS, CHRISTIAN. A Dutch mathematician and author of a work on pendulums. He was born at the Hague on 14th of April, 1629. In 1665, Louis XIV. invited him to Paris for the purpose of founding a Royal Academy of Science. He resided in Paris from 1666 to 1681, when he returned to Holland. In the year 1656, he first conceived the idea of applying a pendulum to a clock, and at once set to work at his task. On the 16th of June, 1657, he presented to the States of Holland his first pendulum clock. In 1658 Adrian Ulaag, of the Hague, published for him in Dutch, a short description of this new clock. In 1673,

finding that Vincent Galileo and others claimed the merit of the adaptation he authorized F. Muguet, of Paris to publish for him a valuable work entitled "Horologium oscillatorium, sive de motu pendulorum ad Horologia aptato," wherein he gave the construction of his clocks, with drawings, and the theory (useless in practice), of the cycloidal checks, as a means of rectifying the variations in the length of the arcs of vibration of the pendulum. Galileo claimed to have adapted a pendulum to a clock as early as 1649, but there appears to be no authority to be relied on, to prove his having done so. Dr. Hooke was another of the claimants

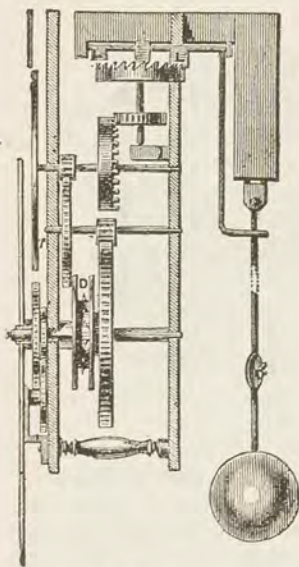

Fig. 169.



Fig. 170.

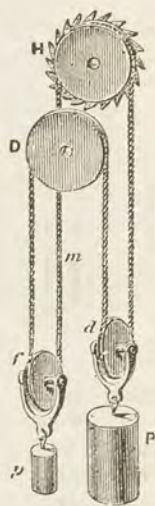

Fig. 171.

for the honor of the first application of the pendulum to a clock, but Nelthropp, after reviewing the question says: But it may without much fear of contradiction be here asserted that to the careful searcher after truth, the following conclusions only can be arrived at. First—That credit ought to be given to Huyghens for being the first to apply the discovery of Galileo to a clock. 2nd. That Dr. Hooke can justly lay claim to having brought the whole matter to perfection by the invention of his anchor escapement, which enabled him to use a long pendulum with a heavy bob, thereby rendering the arcs of vibration shorter, and necessitating much less motive power.

Huyghens' clock is shown in Fig. 169. The upper part of the pendulum is a double cord hanging between two cycloidal checks, to give a

epicycloidal path to the bob. Fig. 170 gives a better idea of the device, which was no doubt of advantage with the long arcs required by the Verge Escapement. Another feature of Huyghens' clock is the maintaining power. The driving weight, P, Fig. 171, is supported by an endless cord passing over the pulley D, attached to the great wheel, and also over the pulley H, which is provided with ratchet teeth and pivoted to the inside of the clock case. The cord *m* is pulled down to wind the clock, and the ratchet wheel H then runs under its click. So that while winding, as in going, one-half of P minus one-half of *p* is driving the clock. The pulleys D and H are spiked to prevent slipping of the cord.

When this ingenious maintaining power is applied to a clock with a striking train, the pulley with the ratchet is attached to the great wheel of the striking part, one weight thus serving to drive both trains. A chain is preferable to a cord, owing to the dust which accumulates in the clock through the wearing of the latter.

HYPOCYCLOID. A curve generated by a point in the circumference of a circle when it is rolled within another circle. The proper shape for the teeth of the wheels that are driven by others having epicycloidal addenda. If the tracing circle is half the diameter of the one within which it rolls, the hypocycloid will be a radial line.

ICE BOX. A box or chamber used when adjusting chronometers and fine watches for temperature. It is usually built in the form of a double box, the ice being placed between the two boxes and both boxes hermetically sealed, so that the movement may not come in contact with damp air. The outer box is provided with a drain pipe for carrying off the water and plate glass is inserted in the front of each box, so that the movement may be viewed without removing it from the box. The cover of the inner box should not be removed for at least two hours after it has been removed from the ice chamber in order to protect the steel work from rust caused by the condensation of the air in the cold metal.

IDLER. 1, An idle wheel. 2, A wheel for transmitting motion from one wheel to another, either by contact or by means of belts, as the wheel on a countershaft, or overhead fixture. 3, An intermediate wheel used for reversing motion. Figs. 172 and 173 illustrate two forms of idlers, sometimes called overhead fixtures. The supports for the idlers are adjustable in all directions. They are especially valuable for use on slide rest tools, such as polisher, milling attachments, etc., to give a vertical direction to the belts. The rods are about 20 inches long and the pattern shown in Fig. 172 has a ball and socket joint where it is screwed to the bench. The radial arms which hold the pulleys may

be adjusted to any position on the rod by means of a thumb screw, and the pulleys have a lateral play of $\frac{3}{4}$ of an inch to aid in maintaining greater freedom of the belt during the travel of the tool on the slide rest. The idlers shown were designed by A. W. Johanson, and have hard rubber pulleys $1\frac{3}{4}$ inches in diameter, having brass bushings. The style shown in Fig. 173 is intended to be clamped on the swiveled bearing of the counter shafts which are supported on standards.

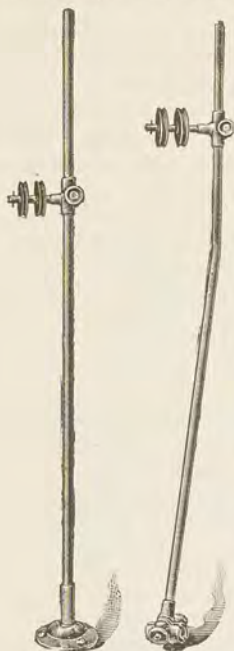

Fig. 172. Fig. 173.

IMPULSE PIN. The ruby pin of the lever escapement which, entering the notch of the lever, unlocks the escape wheel and then receives impulse from the lever and passes out at the opposite side.

INDEPENDENT SECONDS. A movement having a seconds hand that is driven by a separate train.

INDEX. The small curved plate with divisions on its face, over which the regulator arm passes. The circular plate at the back of a lathe head, having holes drilled around its margin for the reception of a pin, for dividing a wheel or other object placed in a chuck. Sometimes called a dividing plate.

INERTIA. That property of matter by which it tends when in rest to remain so, or when set in motion to continue so.

INGOLD FRAISE. A pinion-shaped cutter used for correcting inaccuracies in the shape of wheel teeth, invented by Ingold, a Swiss watchmaker. This consists really of a hardened pinion with square, sharp points. The fraise is gradually brought into depth, in a specially arranged depth tool, with a wheel whose teeth are incorrect, and rotated the while by means of a ferrule and bow. The fraises do not supercede the rounding up tool, but may often be used after it with advantage, for if a wheel contain any thick teeth they would not be corrected in the rounding up tool, which also of necessity leaves the teeth slightly hollow. The fraises cut the teeth in the direction they move on the pinion in working, and, therefore, leave a surface which works with the least friction.

A fraise for any particular wheel should be chosen so that, when placed upon the wheel, the fraise does not bottom, but just touches the sides and almost closes over the middle one of the teeth engaged, at the same

time just making contact with the teeth right and left. If the fraise chosen is too large, it will cut a jagged and uneven tooth; and, if too small, will leave a ridge or shoulder on the tooth; in this, as in everything else, practice makes perfect. As a guide at first, it will be prudent to use the sector to ascertain the most suitable fraise for use; thus—place the wheel to be operated upon in the sector, and choose a fraise of such size as will correspond, not to the size indicated by the number of its teeth, but to *two teeth less*.

INVOLUTE. The curve traced by the end of a string wound upon a roller or unwound from it. This was a favorite shape for wheel teeth at one time, but was abandoned because it was found that the pressure on the pivot was increased by it, and it is now entirely superseded by the epicycloidal.

ISOCHRONAL. Uniform in time; moving in equal time. When the long and short arcs of a balance are caused to be performed in the same time by means of a hairspring, that spring is said to be an isochronal one, or isochronous. When the vibrations of a pendulum are all of the same duration, no matter through what extent of arc the pendulum moves, the vibrations are isochronal.

JACOT PIVOT LATHE. A tool used but little in this country, the American lathe and its attachments having superseded it. It is used for reburnishing and dressing up pivots.

JANVIER, ANTIDE. He was celebrated for his skill in representing planetary movements by the aid of mechanism. He was a profound mathematician. He was born at Saint-Claude-du-Jura, in 1751, and died in 1835.

JAPANESE CLOCKS. The Japanese use a clock which divides the day into twelve hours, and an attempt is made to follow the variations of the solar day, so that the period from sunrise to sunset shall be divided into six equal portions, which vary in length according to the season. These clocks are of three kinds. The first has a dial, on which the hours are printed, which turns with a varying speed, according to the season, while the time is denoted by means of a fixed index. The second has a dial rotating with a constant rate, but the points indicating the hours approach automatically nearer to the center when the season calls for shorter hours. The third has no dial, but instead uses a vertical scale which is traversed by an index attached to the weight; see Figs. 174 and 175. The works consist of the drum, B, around which the cord winds from two other wheels, and a verge balance with spiral spring. Three

thousand eight hundred vibrations are produced for each revolution of the drum. The weight is composed of the striking works and carries the index A, which points to the hours as the weight descends. The striking works consist of a barrel *b*, Fig. 176, with spring and a train of four

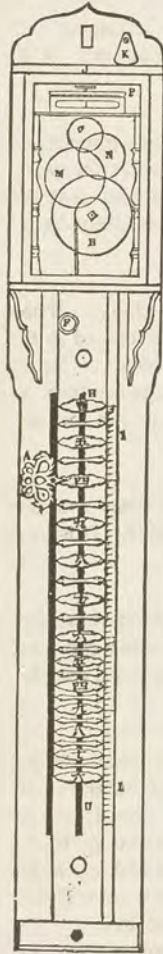

Fig. 174.

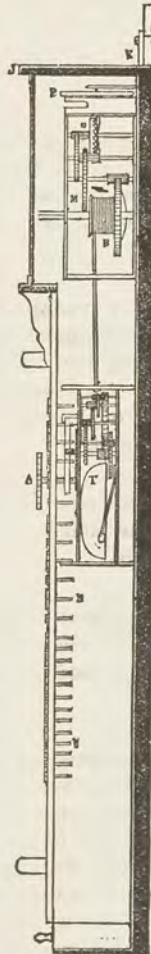

Fig. 175.

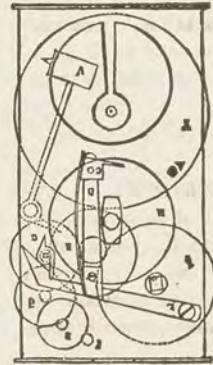

Fig. 176.



Fig. 177.

wheels, ending with a lone pinion. The first wheel, *a*, carries pins which control the hammer to strike the gong *T*; the second wheel, *c*, carries an elbow which stops the train and raises the bascule *L* with one end, while

the other end impels the wheel R at each revolution. The weight strikes against the pins *h, b*, Fig. 175, as it descends. These pins act successively on the arm L, Fig. 176, turning the bascule G and liberating the hammer, which strikes the gong. The wheel R, Fig. 177, has three cuttings that allow but one stroke of the hammer, and three others that allow two strokes, the remainder being divided so as to give 4, 5, 6, 7, 8 and 9 strokes respectively.

JEROME, CHAUNCEY. Mr. Jerome was one of the earliest clockmakers of America and at one time was one of the largest manufacturers. He was born at Canaan, Conn., June 10, 1793. In 1816 he



Chauncey Jerome.

went to work for Eli Terry, then the largest manufacturer of clocks in America. In 1817 he started in the business of clockmaking for himself in a small way. He put up the first circular saw ever used in Bristol, in 1822. In 1824 he organized a company for the manufacture of clocks. In 1838 he put the first brass clock upon the market. In 1842 he introduced these brass clocks in England, being the first American manufacturer of clocks who succeeded in establishing a trade with England. In 1850 he organized the Jerome Manufacturing Company, which carried on the large clock business of its time. Owing to poor management the company failed in 1855, and Jerome, although a very rich man at one time, was hopelessly ruined by this failure. This company was succeeded by the New Haven Clock Company.

JEWEL. In watch work, a stone having a hole pierced in it for the reception of a pivot. To Nicholas Facio, a native of Genoa, is attributed the invention of piercing stones for this purpose, early in the eighteenth century. See *Facio*.

JEWEL HOLDER. This tool, which is shown in Fig. 179, is intended for holding jewels when cleaning and manipulating, and is far superior to the ordinary tweezers as it holds the jewel firmly and there



Fig. 179.

in no danger of it snapping out as with tweezers. The jaws being made of boxwood it will not injure the finest setting. The metal parts are of German silver.

JEWELING. The act of fitting in jewels for pivots to run in, to diminish wear of the acting parts. Sapphires and rubies are used in the better class of work, while in cheaper watches garnets are substituted. In escapement holes, where endstones are used, as in Fig. 181, the jewel



Fig. 180.



Fig. 181.

in a loose setting is fitted into a recessed hole, and upon it the end-stone, also set in metal, is laid, and the whole secured by two small screws. In cheaper movements the jewel is rubbed in, as shown in Fig. 180. *

JEWELING TOOL. Fig. 182 illustrates Hutchinson's Automatic Jeweling Tool. To cut a setting for a jewel, place tool in tail-stock and taper in head of lathe, and see that corner of cutter E comes to center. If it does not, turn screw D back or forward until it comes to the center. Now drill hole half as large as the jewel you wish to set; then place jewel in slot A, and bring index finger over until jewel is tight in slot A, being careful to have jewel in center of slot and not to one side. Now turn set screw C up tight and tool will cut setting exact size.

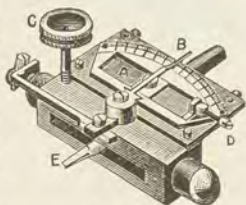

Fig. 182.

JEWELING AND STAKING TOOL. Hopkins' patent jewelery and staking tool, shown in Fig. 183, is an ingenious device, and one that will be found very useful to the watch repairer. As the spindle, or handle, to which the cutters and burnishers P. P. are attached, is sustained in upright position when in use, by the long bearings through which it passes in the upright F. independently of the lower center, the hole to be cut may be centered either from below or above as preferred; and the depth to which it is desired a cutter shall work is regulated by adjustment of the sliding collar E, and this being a correct uprighting, as well as jewelery tool, with it a pivot hole, or a jewel setting the correct center (upright) of which has been lost, may readily be corrected, or its true center again found, and, what in some cases would be a very desirable consideration, by careful manipulation with the cutter, which is under perfect control of the operator, the position of jewel settings may be so changed so as to alter the depth of locking of the wheels to any desired

* For full directions in regard to making and setting jewels the reader is referred to Watch and Chronometer Jeweling, published by Geo. K. Hazlitt & Co., Chicago.

extent. To regulate the depth to which it is desired a cutter shall work below the surface of a plate, lower the spindle D till, when moved out sufficiently far, the end of the cutter will rest down on the top of the plate to be operated upon, and fasten it there by lightly tightening the screw K; this done, adjust and fasten the collar E on the spindle D, to the

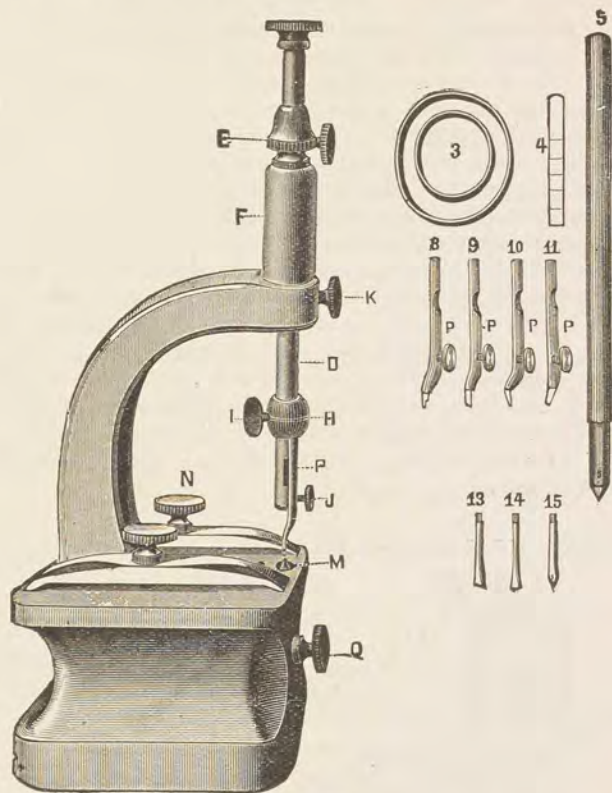

Fig. 183.

same height above the top of the upright F as it is desired the cutter shall work below the surface of the plate on which it now rests. This, when the spindle D has been again set free by loosening the screw K, will of course allow the cutter to sink into the hole to be operated upon to the exact distance the collar E had been set above the top of F. In adjusting the collar E, the graduated wedge, No. 4, or the jewel to be set, as preferred, may be used as a gauge. The burnishers, No. 9, are used both for opening and closing settings; the same burnisher, having chosen one

of proper size, is used for both purposes ; the side being used for opening the setting, and the beveled and rounded end for burnishing it down again over the jewel. The pieces 13 and 14 are made to fit in the lower end of the spindle D (the cutter P having been removed), same as an ordinary drill stock, and are used for burnishing the edges of a jewel setting down flat over the jewel, countersinking screw heads, giving end shake to wheels, etc.; and being easily made, any one owning the tool can make these for himself, of forms and sizes to suit the particular work in hand. For uprighting purposes, withdraw the spindle D and substitute No. 5, the rings, No. 3, being intended for laying the work on, on the tool bed. For upright drilling through watch plates, mark the place to be drilled (prick punch it slightly) with the cone point of No. 5 ; which done, turn the spindle No. 5 upside down and rest the upper end of the drill in the countersink in its end, the drill being operated with a fiddle bow acting on a collet placed on its shank for the purpose. For cutting off bushings level with a watch plate, either a cutter of the No. 13 or 14 class, or one of the P cutters can be used. For staking or riveting wheels upright on their pinions, lay the stake No. 7 level on the tool bed (the center M having been fastened down out of the way), and with No 5 center accurately the hole to be used in the stake, and fasten it there by means of the clamps N; then remove the cone end of No. 5, and place a punch with hole in its end of the required size, on the part m, and proceed as in an ordinary upright staking tool.

JEWELING CALIPER REST. This tool will be found very

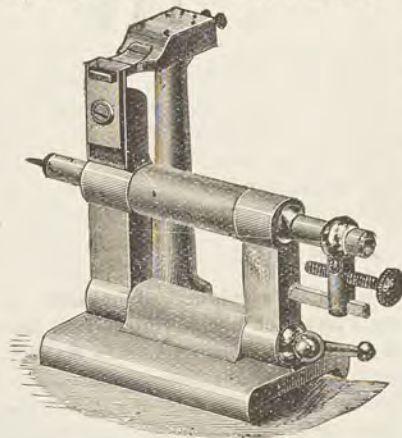

Fig. 184.

useful for setting jewels in plates or settings, in countersinking for screw heads, opening wheels for pinions or bushings, turning barrel heads, etc. The sliding jaws of the calipers should be so adjusted that when the swinging part is brought back snugly against them, the front cutting edge of the cutter in the sliding spindle will exactly line with the center of the lathe spindle. Then if the calipers are at the right height, when a jewel or jewel setting is placed in the jaws of the caliper it will move the edge of the cutter outward from the lathe center just half the diameter of the jewel then in the caliper, and the cutting made at that distance

from the center will exactly coincide with the size of the jewel to be set. If however, if set and worked as above, it is found that the hole cut is too large for the jewel, it will indicate that the calipers are too low down, and should be raised, provision for which is made in the construction of the tool. If on the other hand, the cutting is found too small to fit, it will indicate the calipers should be lowered. The final cutting for the jewel seat should be made by running the center straight inward from the face of the plate; the adjustable screw stop on the back end of the sliding spindle serving to gauge the depth of the cutting.

JEWEL PIN. To set a jewel pin in the table roller (of American watches) correctly, is a difficult task. Where the jewel pin is broken off, you will often save much valuable time by examining the broken part with your glass and noting the exact location of the pin before disturbing it. In some movements the jewel pin will be set as in Fig. 185, occupying about two-thirds of the hole, in another movement the pin will not occupy much over one-half the space, as shown in Fig. 186. By using care in selecting a jewel pin of precisely the same size as the old one and in inserting it in the same place, nine out of every ten movements will be found mechanically perfect and the balance have a good motion if the escapement is perfect. Most watchmakers remove the table roller from the balance staff, in case the jewel pin is loose. This you will find unnecessary if you will make the following described tool and use as directed.

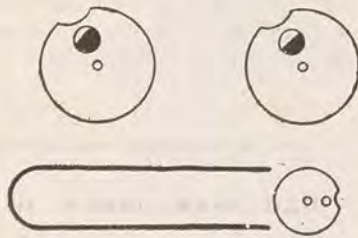

Fig. 185.

Fig. 186.

Fig. 187.

Take a piece of copper wire about half the thickness of a common pin tongue and bend it as shown in Fig. 187, so that it will be about one and one-eighth inch long. Cut or saw a groove in the inside of the ends, sufficiently deep to hold on to the table roller, say one-fourth inch from the end. This can be easily bent to accommodate all sizes of tables. If you wish to soften the cement, to tighten or replace a new jewel pin, it is only necessary to slip on the copper wire, and hold the extreme outer end in the flame of a small alcohol lamp a few moments and sufficient heat will follow the copper wire to soften the cement. Care must be exercised to keep the pin in the proper position, and when sufficiently heated, remove the wire quickly and allow the table to cool. By use of this little tool there is no need of removing the table roller, and absolutely no danger of injuring the finest expansion balance, as the tool need not, and must not touch the balance. The end of this tool is held in the flame by a pair of

soldering tweezers. Always use shellac for cementing the jewel pin in the table roller.

JEWEL PIN SETTER. Fig 188 illustrates the Logan patent. It is an excellent tool and will save the workman considerable time and



Fig. 188.

much annoyance by its use. Every watchmaker is aware what a difficult and tedious matter it is to set a jewel pin correctly. With this tool the job is accomplished quickly and accurately.

JODIN, JEAN. A clever French watchmaker of the eighteenth century. Author of a work on horology. He was the first to point out that success in the timing of horizontal watches depends on the correct proportioning of all their parts.

JOINT PUSHER. A small piece of tempered steel wire mounted in a wooden handle and used for inserting and removing joint pins.

JURGENSEN, URBAN. He was born at Copenhagen, Denmark, August 5, 1776. His father was a watchmaker to the court, and under him Urban learned the art. At the age of twenty-one he visited Neuchâtel, Switzerland, where he remained for eighteen months and afterwards resided for six months in Geneva, being constantly occupied with mathematical and practical work. He afterwards went to Paris and was admitted to the houses of M. Breguet and Ferdinand Berthoud, and for some time worked under the immediate instruction of the former. He spent some time in London and then returned to Paris, and from there went to Geneva and Neuchâtel. He returned to Denmark in 1801, and was offered a partnership with a very clever artist, M. Etienne Magnin, who for some years had enjoyed a royal bounty to make longitude-chronometers for the use of ships. Young Jurgensen, however, preferred to enter into partnership with his father, and his younger brother, Frederick, afterwards court watchmaker, was his first pupil. In 1804 he compiled a memoir entitled, "On the Art of Watchmaking," or "Rules for the Exact Measurement of Time," which was published at royal expense. A new and improved edition was published the following year in French. In the same year he received the silver medal of the Royal Society of Sciences, at Copenhagen, for a treatise entitled, "On the best

mode of making and hardening Watch Springs." He resolved, owing to the scarcity of competent help and his own poor health, to remove to Switzerland, and accordingly in 1807 he removed to Neufchatel, where he remained two years. In 1809 he returned to Denmark. In 1815 he was made a member of "The Royal Society of Sciences." In 1822 he was made superintendent of all chronometers belonging to the Royal Navy, and in 1824 he was decorated with the Gold Cross of Dannebrog. He died on the 14th of May, 1830, being 53 years old.

JURGENSEN, JULES. Son of Urban and one of the most noted watchmakers of the 19th century. He was born at Locle, July 27, 1808, during the temporary residence of his parents in Switzerland. During his youth he worked under the immediate instruction of his father, but in 1835 he went to Switzerland, and from there to Paris and London, where he studied under the best masters in physics, mechanics and astronomy. Later he established a branch of his father's business in Locle and devoted his attention to the construction of pocket chronometers. The result of his study and experiments was the celebrated Jurgensen watch of to-day. The last years of his life were spent in Geneva and he died December 17, 1877. His son, Jules F. U. Jurgensen, succeeded to the business.



Jules Jurgensen.

KENDALL, LARCUM. A noted watchmaker of London, who constructed a timekeeper on Harrison's principle, which was given to Captain Cook, when he commanded the *Resolution*, in 1776.

KULLBERG, VICTOR. A prominent horologist and successful chronometer maker. He was born at Wisby, on the Island of Gothland, in 1824. He went to London in 1851, where he remained until his death. His chronometers stood at the top of the list in the trials from 1880 to 1890 inclusive. He died July 7, 1890.

LACQUER. The ordinary lacquer of commerce is composed of spirits of wine and clear shellac in the proportion of 1 oz. of shellac to a pint of spirit. Heat should not be applied, but the ingredients placed in a glass stoppered bottle and shaken from time to time until the shellac is thoroughly dissolved or combined with the spirit. Various tints may be given lacquer by adding small quantities of aniline colors, previously well mixed with water and free from lumps.

LANGE, ADOLPH. Adolph Lange was born in Dresden, in 1815, and was apprenticed to a watchmaker of that place. At the expiration of his apprenticeship he went to Paris to perfect himself in the higher branches of horology. He became the foreman in the celebrated workshop of Winnerl. He later returned to Dresden, where he became the partner of his former master. He devoted himself to the manufacture of astronomical clocks, chronometers and fine watches, and soon secured



Adolph Lange.

for himself an enviable reputation. About this time the government of Saxony was in search of some means of bettering the condition of the inhabitants of the mountainous districts of Saxony. The condition of these people was most pitiable, as for generations they had lived there in extreme poverty. Mr. Lange was confident that if the art of watchmaking was introduced into this region the desired result might be achieved. The government looked favorably on his proposition, and in 1845 he, with the assistance of the State, established a watchmaker's school at Glashutte. The populace did not take kindly to the idea, and it was very up-hill work for awhile; but his efforts were finally crowned with success. He taught the youths of the village the art of watchmaking and installed them in his workshop. In less than two years the first watches were marketed, and the success of the enterprise assured. In time his pupils became teachers, and gradually, but surely, the art of horology gained a foothold, until now nearly the entire population of Glashutte are engaged in horological and kindred pursuits. He died Dec. 5, 1875, leaving two sons, Richard and Emile, who are still engaged in manufacturing fine watches, chronometers and clocks of precision, in Glashutte.

LANTERN PINION. A pinion formed of two circular brass, or other metal plates, and connected by means of short steel wires.

LAP. A disc used in conjunction with a lathe for polishing or cutting. Laps are made of steel, copper, ivory, etc., and are charged with the cutting or polishing compounds. See *Diamond Laps*.

LATHE. A mechanical device used for shaping articles by causing them to revolve while being brought into contact with cutting tools. Those who contemplate buying a lathe will do well to avoid the cheap imitations of the American pattern, which are made by irresponsible makers in foreign countries, and foisted upon an unsuspecting public, and guaranteed true and "as good as the American." They are usually nicely finished, but inferior both in material and workmanship, their greatest failure being their untruth. If an untrue American lathe, by any possibility is allowed to escape the inspector and finds its way upon the

market, the manufacturer is only too glad to exchange it for a perfect article, for his reputation is at stake; but who are you going back on in the event of one of these cheap imitations proving untrue? There are American made lathes upon the market that are as inferior in many respects as the imitations, and the watchmaker will do well to do without a lathe until such time as he can afford to purchase one of known

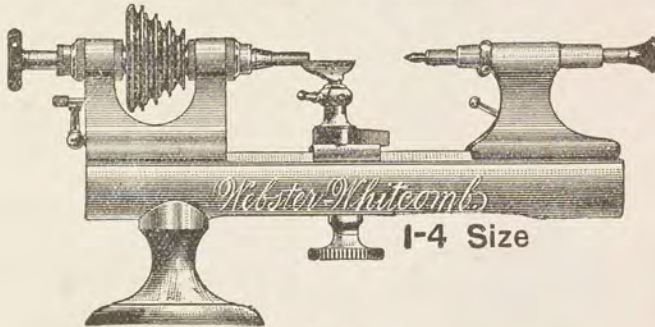

Fig. 191.

reputation. Among the first class American lathes upon the market may be mentioned the Webster-Whitcomb, Fig. 191; the Moseley, Fig. 192; the Hopkins, Fig. 193, and the Rivett, Fig. 194.

An excellent lathe for the heavier work of watchmakers and jewelers, such as cannot be performed with satisfaction on the watchmaker's lathe, is the No. 4 Barnes, which is shown in Fig. 195.

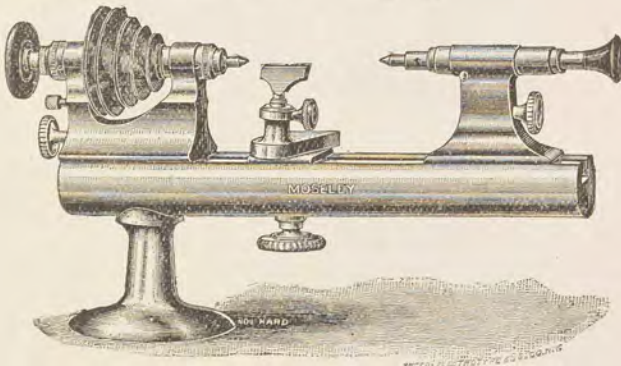

Fig. 192.

It is manufactured by the W. F. & John Barnes Company, Rockford, Ill. For screw cutting, the manufacture of watchmaker's tools, fishing reels, repairs on tower clocks, in fact, all the heavier work of the trade, it is admirably fitted.

The American lathe of to-day is a marvel of completeness in its parts, and how many hours, yea months, of study and experiment have been bestowed upon it by its projectors and makers to acquire these points of utility and excellency. What a vast amount of care has been exercised for the production of a perfect lathe! Must this care cease at the moment the lathe passes into the hands of the watchmaker?

It is a very easy matter at any time to wipe off the dust and oil that may accumulate, but does this alone constitute due care? There may be a nice glass case to cover it and keep off the dust, and a very good idea it is, if faithfully used; but if a counter shaft is on the bench, or much lathe work is to be done, it soon falls into blissful desuetude, or finishes its usefulness by being broken. Then, often, a cloth is wrapped about the lathe, which soon gets soiled and looks badly, let alone the poor protection it affords.

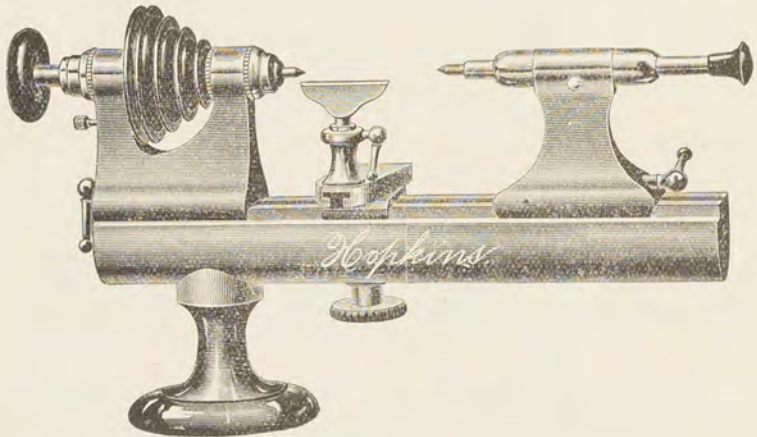

Fig. 193.

Dust is omnipresent and the greatest enemy to all active machinery; it insidiously makes its way into every crease and crevice, and if not promptly removed will cause untold damage. We cannot get rid of it and must (like the industrious housewife) wage a constant warfare against it.

The care necessary to be given to a fine lathe differs from most other tools; it is not confined alone to the removal of dust and keeping clean, but the fitting properly of the several parts as used. There should be no overstraining when tightening screws, chucks, etc., or when fitting articles in both wire and wheel chucks, and so on through the list.

The face of the lathe bed when it comes from the makers is (or should be) perfectly true from end to end, in order that head and tail stocks will meet on a direct line of centers, even should they be changed and

for end, and a good lathe will meet those requirements. Now, it is obvious to any thinking mind that if the face becomes injured by neglect, whereby the nickling is removed in spots or portions, they will, in all probability, become rusty; this rust will then eat away and throw off more, and soon the face presents an uneven surface, which will tend to destroy the lines of centers between head and tail stocks.

The head stock, usually occupying one position, causes less wear at this point or place, while the hand rest and tail stock are constantly being shifted, so where there is more motion or action there must

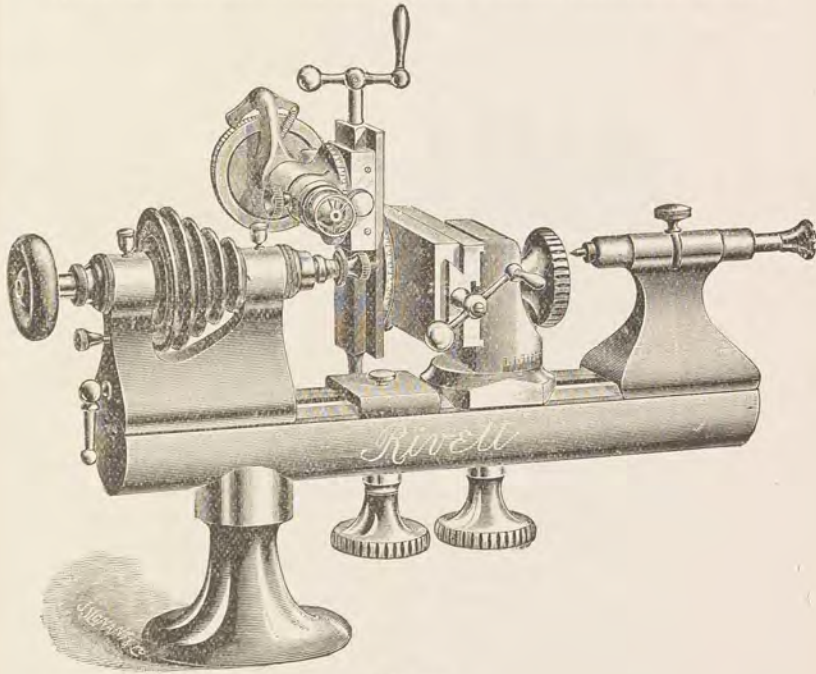

Fig. 194.

be more wear, especially if dust, chips, or grit be allowed to accumulate beneath them, and though the wear is seemingly imperceptible, it nevertheless is there, and will sooner or later manifest itself, and this is a signal that the level of the bed is becoming impaired, and necessarily the truth. Thus too much care and attention cannot be exercised in guarding against chips and dust when sliding hand rest back and forth on the bed.

At the end of the bed, where the tail stock takes position, many watch-makers have the tail stock off, and this portion is more exposed to

atmospheric action, also receiving perspiration from the hands when they come in contact. Again, others let the tail stock remain in position, only removing when it comes in the way. In the former case, it is well to devise some means for the protection of the bed; this is easily done by making a sheath of chamois skin to slip tightly over the bed; it can be removed and replaced readily, and when it becomes soiled, can be washed.

This sheath should be fully two-thirds the length of bed, or reaching from tail end up to hand rest when it is close to head stock. It preserves the bed from dampness, which is considerable in some climates, also the perspiration of the hand and flying chips and dust. In the second case, if the tail stock is allowed to remain on lathe, or, if removed and placed on the bench, it is subjected to all the evils the bed is in the former.

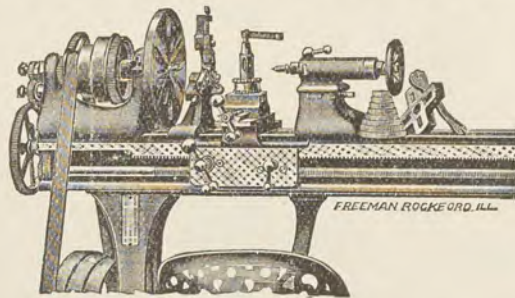

Fig. 195.

Our opinion is, the tail stock should be kept in its compartment in a tight fitting drawer, away from dust and accidental knocks of other tools on the bench; the tail spindle not being nicked, is more liable to rust if left exposed, and should be kept wrapped in a sheath of oiled paper. This may seem superfluous and too much bother, yet it is taking proper care which tells in the end.

The bottom of tail stock should always be brushed off before placing in position, not only for its protection, but for fear some particle of grit may be adhering, thereby throwing it out of truth, and screwing it down tight only adds injury to the lathe if allowed to remain.

The head stock demands close attention; the spindle should run freely without end shake, and about once a week should be speeded, meanwhile administering oil until it leaves the bearings clean, and then wiped off. A little oil should be added every day. See that the mouth of the spindle is kept bright and clean; thrust a strip of cloth clear through spindle every now and then, that all dust and dirt may be removed.

Wire and wheel chucks should often be washed in gasoline to remove gummy dirt and oil which is constantly adhering, and it is even well each time a chuck is used, to wash off first, then wipe dry. A little dirt

on mouth of spindle, or on chuck, often throws it out of truth, and consequently the article fastened therein also.

When fitting head or tail stocks, or in fact any attachment, do so carefully. Do not bang it in place as if you held a grudge against it, and when in position see that they are tightly screwed in place.

Having too much end shake on live spindle, especially in soft lathes, causes uneven wear in its bearings, besides not being reliable for true pivoting or any such work.

When the cost of a lathe is taken into consideration, it goes to prove that it is not easily replaced. Where is the jeweler with a stock of goods who would retire without first seeing his valuables were in the safe, but how many are there who think of giving this protection to their lathes? Some do, but the greater per cent do not. "It is a 'pious plan' to see that the head stock, tail stock, and attachments are in the safe, and should a fire break out that endangers the store, and no chance to save it, the feeling of satisfaction is great to know the lathe is safe, that is, the more expensive parts, for the bed can be purchased at a nominal cost compared to the attachments.

A word about chuck blocks or stands. The best kinds are those made to fit in a drawer of the bench and the holes sunk deep enough to let the chuck (wire) drop full length, or to the head, the hole being counter-sunk to admit the bevel portion. They can easily be picked out with the finger nail. Have the block thoroughly soaked with oil.

To prevent rusting of tools, and especially if the bed shows signs of rust spots, here is a good old remedy: Procure some blue ointment, spread it on a cloth and rub the tools or lathe briskly, then wipe off with a clean cloth, and wipe dry. This ointment leaves a thin coating of mercury which prevents the action of dampness on the tools. This cure need not be resorted to more than once a month, and keep ointment away from gold cases and watch movements. If you find your lathe bed has got in such a condition as to destroy its truth, send it at once to the makers and have it put in first-class condition. Do not trust it, for the sake of saving a little, to some irresponsible firm for repairs.

LEPAUTE, J. A. One of the most celebrated of French horologists. He did much to improve his art, especially in regard to turret clocks. He was the author of a volume on horology, which in its time was a standard authority. He was born at Montmedi in 1709 and died in 1789.

LEPINE MOVEMENT. An extremely thin bar movement. Lepine introduced his improvements in 1776 and they consisted of the suppression of the pillar plate, the fuzee and chain and one of the supports to the barrel arbor. The Lepine family resided at Fer-

ney, near Geneva, where Voltaire established a watch factory. Brequet improved on the Lepine system by causing the mainspring to be wound up at the back of the watch through the dome, instead of by a square through the face of the dial.

LE ROY, JULIEN. A celebrated French horologist. He was the inventor of the horizontal mechanism for turret clocks. He introduced improvements in nearly all the branches of horology of his day. He died in 1759.

LE ROY, PIERRE. A son of Julien Le Roy and unquestionably the greatest of all French horologists. He was born in 1717 and died in 1785. He was the inventor of the Duplex escapement.

LESSELS, M. A celebrated German clockmaker who worked for a long time with Brequet. He was the maker of a number of excellent astronomical clocks for Swiss, German and Russian observatories. He died in 1849.

LEVER ESCAPEMENT.* The lever escapement is derived from Graham's deadbeat escapement for clocks. Thomas Mudge was the first horologist who successfully applied it to watches in the detached form, about 1750. The locking faces of the pallets were arcs of circles struck from the pallet centers. Many improvements were made upon it until to-day it is the best form of escapement for a general purpose watch, and when made on mechanical principles is capable of producing first rate results.

It is not obligatory in the lever, as in the verge, to have an uneven number of teeth in the wheel. While nearly all have 15 teeth, we might make them of 14 or 16; occasionally we find some in complicated watches of 12 teeth, and in old English watches of 30, which is a clumsy arrangement, and if the pallets embrace only three teeth in the latter, the pallet center cannot be pitched on a tangent.

Although advisable from a timing standpoint that the teeth in the escape wheel should divide evenly into the number of beats made per minute in a watch with seconds hand, it is not, strictly speaking, necessary that it should do so, as an example will show. We will take an ordinary watch, beating 300 times per minute; we will fit an escape wheel of 16 teeth; multiply this by 2, as there is a forward and then a return motion of the balance and consequently two beats for each tooth, making $16 \times 2 = 32$ beats for each revolution of the escape wheel. 300 beats are made per minute; divide this by the beats made on each revolution, and we have the number of times in

*The student will do well to read: The Detached Lever Escapement, by Moritz Grössman; Modern Horology in Theory and Practice, by Claudius Saunier, and Watch and Clock Making, by David Glasgow.

which the escape wheel revolves per minute, namely, $300 \div 32 = 9.375$. This number then is the proportion existing for the teeth and pitch diameters of the 4th wheel and escape pinion. We must now find a suitable number of teeth for this wheel and pinion. Of available pinions for a watch, the only one which would answer would be one of 8 leaves, as any other number would give a fractional number of teeth for the 4th wheel, therefore $9.375 \times 8 = 75$ teeth in 4th wheel. Now as to the proof: as is well known, if we multiply the number of teeth contained in 4th and escape wheels also by 2, for the reason previously given, and divide by the leaves in the escape pinion, we get the number of beats made per minute; therefore $\frac{75 \times 8 \times 2}{8} = 300$ beats per minute.

Pallets can be made to embrace more than three teeth, but would be much heavier and therefore the mechanical action would suffer. They can also be made to embrace fewer teeth, but the necessary side shake in the pivot holes would prove very detrimental to a total lifting angle of 10° , which represents the angle of movement in modern watches. Some of the finest ones only make 8 or 9° of a movement; the smaller the angle the greater will the effects of defective workmanship be; 10° is a common-sense angle and gives a safe escapement capable of fine results. Theoretically, if a timepiece could be produced in which the balance would vibrate without being connected with an escapement, we would have reached a step nearer the goal. Practice has shown this to be the proper theory to work on. Hence, the smaller the pallet and impulse angles the less will the balance and escapement be connected. The chronometer is still more highly detached than the lever.

The pallet embracing three teeth is sound and practical, and when applied to a 15-tooth wheel, this arrangement offers certain geometrical and mechanical advantages in its construction, which we will notice in due time. 15 teeth divide evenly into 360° leaving an interval of 24 degrees from tooth to tooth,



Fig. 196.

which is also the angle at which the locking faces of the teeth are inclined from the center, which fact will be found convenient when we come to cut our wheel.

From locking on the pallet scaping over three teeth, the angle is 60° , which is equal to $2\frac{1}{2}$ spaces of the wheel. Fig. 196 illustrates the lockings, spanning this arc. If the pallets embraced 4 teeth, the angle

would be 84° ; or in case of a 16-tooth wheel scaping over 3 teeth, the angle would be $\frac{360 \times 3}{16} = 56\frac{1}{4}^\circ$.

Pallets may be divided into two kinds, namely: equidistant and circular. The equidistant pallet is so-called because the lockings are an equal distance from the center; sometimes it is also called the tangential escapement, on account of the unlocking taking place on the intersection of tangent AC with EB, and FB with AD, the tangents, which is the valuable feature of this form of escapement.

AC and AD, Fig. 197, are tangents to the primitive circle GH. ABE and ABF are angles of 30° each, together therefore forming the angle FBE of 60° . The locking circle MN is struck from the pallet center A; the interangles being equal, consequently the pallets must be equidistant.

The weak point of this pallet is that the lifting is not performed so favorably; by examining the lifting planes MO and NP, we see

that the discharging edge O, is closer to the center, A, than the discharging edge, P; consequently the lifting on the engaging pallet is performed on a shorter lever arm than on the disengaging pallet, also any inequality in workmanship would prove more detrimental on the engaging than on the disengaging pallet. The equidistant pallet requires fine workmanship throughout. We have purposely shown it of a width of 10° , which is the widest we can employ in a 15-tooth wheel, and shows the defects of this escapement more readily than if we had used a narrow pallet. A narrower pallet is advisable, as the difference in the discharging edges will be less, and the lifting arms would, therefore, not show so much difference in leverage.

The circular pallet is sometimes appropriately called "the pallet with equal lifts," as the lever arms AMO and ANP, Fig. 198, are equal lengths. It will be noticed by examining the diagram, that the pallets are bisected by the 30° lines EB and FB, one half their width being placed on each side of these lines. In this pallet we have two locking circles, MP, for the engaging pallet, and NO for the

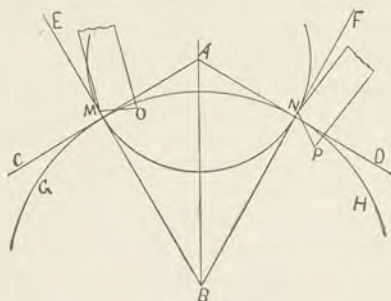

Fig. 197.

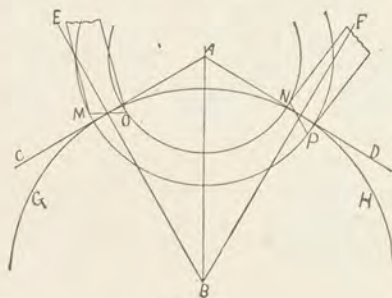

Fig. 198.

disengaging pallet. The weak points in this escapement are that the unlocking resistance is greater on the engaging than on the disengaging pallet, and that neither of them lock on the tangents AC and AD, at the points of intersection with EB and FB. The narrower the circular pallet is made, the nearer to the tangent will the unlocking be performed. In neither the equidistant or circular pallets can the unlocking resistance be *exactly* the same on each pallet, as in the engaging pallet the friction takes place before AB, the line of centers, which is more severe than when this line has been passed, as is the case with the disengaging pallet; this fact proportionately increases the existing defects of the circular over the equidistant pallet, and *vice versa*, but for the same reason, the lifting in the equidistant is proportionately accompanied by more friction than in the circular.

Both equidistant and circular pallets have their adherents; the finer Swiss, French and German watches are made with equidistant escapements, while the majority of English and American watches contain the circular. In our opinion the English are wise in adhering to the circular form. We think a ratchet wheel should not be employed with equidistant pallets. By examining Fig. 197, we see an English pallet of this form. We have shown its defects in such a wide pallet as the English (as we have before stated), because they are more readily perceived; also, on account of the shape of the teeth,

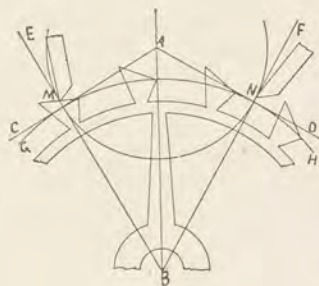

Fig. 199.

there is danger of the discharging edge, P, dipping so deep into the wheel, as to make considerable drop necessary, or the pallets would touch on the backs of the teeth. In the case of the club tooth, the latter is hollowed out, therefore less drop is required. We have noticed that, theoretically, it is advantageous to make the pallets narrower than the English, both for the equidistant and circular escapements. There is an escapement, Fig. 199, which is just the opposite to the English. The entire lift is performed by the wheel, while in the case of the ratchet wheel, the entire lifting angle is on the pallets; also, the pallets being as narrow as they can be made, consistent with strength, it has the good points of both the equidistant and circular pallets, as the unlocking can be performed on the tangent and the lifting arms are of equal length. The wheel, however, is so much heavier as to considerably increase the inertia; also, we have a metal surface of quite an extent sliding over a thin jewel. For practical

reasons, therefore, it has been slightly altered in form and is only used in cheap work, being easily made.

We will now consider the drop, which is a clear loss of power, and, if excessive, is the cause of much irregularity. It should be as small as possible consistent with perfect freedom of action.

In so far as *angular* measurements are concerned, no hard and fast rule can be applied to it, the larger the escape wheel the smaller should be the angle allowed for drop. Authorities on the subject allow $1\frac{1}{2}^\circ$ drop for the club and 2° for the ratchet tooth. It is a fact that escape wheels are not cut perfectly true; the teeth are apt to bend slightly from the action of the cutters. The truest wheel can be made of steel, as each tooth can be successively ground after being hardened and tempered. Such a wheel would require less drop than one of any other metal. Supposing we have a wheel with a primitive diameter of 7.5 mm., what is the amount of drop, allowing $1\frac{1}{2}^\circ$ by angular measurement? $7.5 \times 3.1416 \div 360 \times 1.5 = .0983$ mm., which is sufficient; a hair could get between the pallet and tooth, and would not stop the watch. Even after allowing for imperfectly divided teeth, we require no greater freedom, even if the wheel is larger. Now suppose we take a wheel with a primitive diameter of 8.5 mm. and find the amount of drop; $8.5 \times 3.1416 \div 360 \times 1.5 = .1413$ mm., or $.1413 - .0983 = .043$ mm., more drop than the smaller wheel, if we take the same angle. This is a waste of force. The angular drop should, therefore be proportioned according to the size of the wheel. We wish it to be understood that common sense must always be our guide. When the horological student once arrives at this standpoint, he can *intelligently* apply himself to his calling.

THE DRAW.

The draw or draft angle was added to the pallets in order to draw the fork back against the bankings and the guard point from the roller whenever the safety action had performed its function.

Pallets with draw are more difficult to unlock than those without it, this is in the nature of a fault, but whenever there are two faults we must choose the less. The rate of the watch will suffer less on account of the recoil introduced than it would were the locking faces arcs of circles struck from the pallet center, in which case the guard point would often remain against the roller. The draw should be as light as possible consistent with safety of action; some writers allow 15° on the engaging and 12° on the disengaging pallet; others again allow 12° on each, which we deem sufficient. The draw is measured from the locking edges M and N, Fig. 200. The locking planes *when locked* are inclined 12° from EB, and FB. In the case of the engaging pallet it inclines toward the center A. The draw is produced on account of MA being longer than RA, consequently, when power is

applied to the scape tooth S, the pallet is drawn into the wheel. The disengaging pallet inclines in the same direction, but away from the center A; the reason is obvious from the former explanation. Some people imagine that the greater the incline on the locking edge of the escape teeth, the stronger the draw would be. This is not the case, but it is certainly necessary that the point of the tooth alone should touch the pallet. From this it follows that the angle on the teeth must be greater than on the pallets; examine the disengaging pallet in Fig. 200, as it is from this pallet that the inclination of the teeth must be determined, as in the case of the engaging pallet the motion is toward the line of centers AB, and therefore *away* from the tooth which partially explains why some people advocate 15° draw for this pallet. As illustrated in the case of the disengaging pallet, however the motion is also toward the line of centers AB, and *towards* the tooth as well, all of which will be seen by the dotted circles MM₂

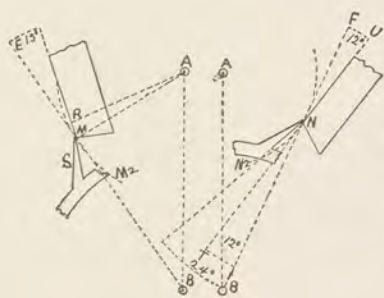

Fig. 200.

and NN₂, representing the paths of the pallets. It will be noticed that UNF and TNB are opposite and equal angles of 12° . For practical reasons, from a manufacturing standpoint, the angle on the tooth is made just twice the amount, namely 24° ; we could make it a little less or a little more. If we made it less than 20° too great a surface would be in contact with the jewel, involving

greater friction in unlocking and an inefficient draw, but in the case of an English lever with such an arrangement we could do with less drop, which advantage would be too dearly bought; or if the angle is made over 28° , the point or locking edge of the tooth would rapidly become worn in case of a brass wheel. Also in an English lever more drop would be required.

THE LOCK.

What we have said in regard to drop also applies to the lock, which should be as small as possible, consistent with perfect safety. The greater the drop the deeper must be the lock; $1\frac{1}{2}^\circ$ is the angle generally allowed for the lock, but it is obvious that in a large escapement it can be less.

THE RUN.

The run or, as it is sometimes called, "the slide," should also be as light as possible: from $\frac{1}{4}^\circ$ to $\frac{1}{2}^\circ$ is sufficient. It follows, then, the

banking should be as close together as possible, consistent with requisite freedom for escaping. Anything more than this increases the angular connection of the balance with the escapement, which directly violates the theory under which it is constructed; also, a greater amount of work will be imposed upon the balance to meet the increased unlocking resistance, resulting in a poor motion, and accurate time will be out of the question. It will be seen that those workmen who make a practice of opening the banks, "to give the escapement more freedom," simply jump from the frying pan into the fire. The bankings should be as far removed from the pallet

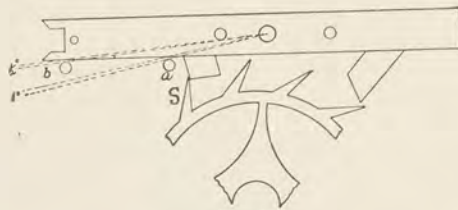

Fig. 201.

center as possible, as the further away they are pitched the less run we require, according to angular measurement. Figure 201 illustrates this fact; the tooth S has just dropped on the engaging pallet, but the fork

has not yet reached the bankings. At *a* we have 1° of run, while if placed at *b* we would only have $\frac{1}{2}^\circ$ of run, but still the same freedom for escaping, and less unlocking resistance.

The bankings should be placed towards the acting end of the fork as illustrated, as in case the watch "rebanks" there would be more strain on the lever pivots if they were placed at the other end of the fork.

THE LIFT.

The lift is composed of the actual lift on the teeth and pallets and the lock and run. We will suppose that from drop to drop we allow 10° ; if the lock is $1\frac{1}{2}^\circ$ then the actual lift by means of the inclined planes on teeth and pallets will be $8\frac{1}{2}^\circ$. We have seen that a small lifting angle is advisable, so that the vibrations of the balance will be as free as possible. There are other reasons as well.

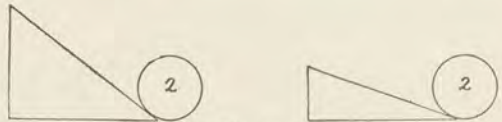

Fig. 202.

Fig. 202 shows two inclined planes; we desire to lift the weight 2 a distance equal to the angle at which the planes are inclined; it will be seen at a glance that we will have less friction by employing the smaller incline, whereas with the larger one the motive power is employed through a greater distance on the object to be moved. The

smaller the angle the more energetic will the movement be; the grinding of the angles and fit of the pivots, etc., also increases in importance. An actual lift of $8\frac{1}{2}^\circ$ satisfies the conditions imposed very well. We have before seen that both on account of the unlocking and the lifting leverage of the pallet arms, it would be advisable to make them narrow both in the equidistant and circular escapement. We will now study the question from the standpoint of the lift, in so far as the wheel is concerned.

It is self-evident that a narrow pallet requires a wide tooth, and a wide pallet a narrow or thin tooth wheel; in the ratchet wheel we have a metal point passing over a jeweled plane. The friction is at its minimum, because there is less adhesion than with the club tooth, but we must emphasize the fact that we require a greater angle in proportion on the pallets in this escapement than with the narrow pallets and wider tooth. This seems to be a point which many do

not thoroughly comprehend, and we would advise a close study of Fig. 203, which will make it perfectly clear, as we show both a wide and a narrow pallet. GH represents the primitive, which, in this figure is also the real diameter of the escape wheel. In measuring the lifting angles for the pallets, our starting point is *always* from the tangents

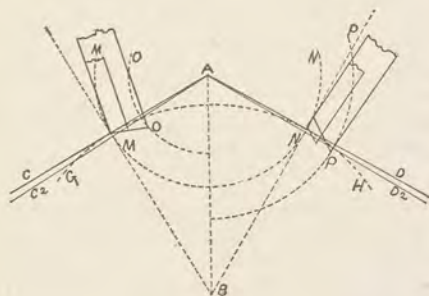

Fig. 203.

AC and AD. The tangents are straight lines, but the wheel describes the circle GH, therefore they must deviate from one another, and the closer to the center A the discharging edge of the engaging pallet reaches, the greater does this difference become; and in the same manner the further the discharging edge of the disengaging pallet is from the center A the greater it is. This shows that the loss is greater in the equidistant than in the circular escapement. After this we will designate this difference as the "loss." In order to illustrate it more plainly we show the widest pallet—the English—in equidistant form. This gives another reason why the English lever should only be made with circular pallets, as we have seen that the wider the pallet the greater the loss. The loss is measured at the intersection of the path of the discharging edge OO, with the circle GH, and is shown through AC₂, which intersects these circles at that point. In the case of the disengaging pallet, PP illustrates the path of the discharging edge; the loss is measured as in the preceding case

where GH is intersected as shown by AD2. It amounts to a different value on each pallet. Notice the loss between C and C2, on the engaging, and D and D2 on the disengaging pallet; it is greater on the engaging pallet, so much so that it amounts to 2° , which is equal to

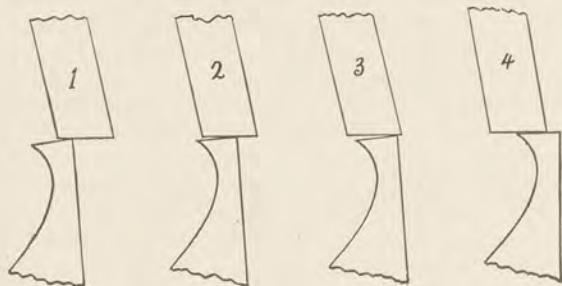

Fig. 204.

the entire lock; therefore if $8\frac{1}{2}^\circ$ of work is to be accomplished through this pallet, the lifting plane requires an angle of $10\frac{1}{2}^\circ$ struck from AC.

Let us now consider the lifting action of the club tooth wheel. This is decidedly a complicated action, and requires some study to comprehend. In action with the engaging pallet the wheel moves *up*, or in the direction of the motion of the pallets, but on the disengaging pallet it moves *down*, and in a direction opposite to the pallets, and the heel of the tooth moves with greater velocity than the locking edge; also in the case of the engaging pallet, the locking edge moves with greater velocity than the discharging edge; in the disengaging pallet the opposite is the case, as the discharging edge moves with greater velocity than the locking. These points involve factors



Fig. 205.

which must be considered, and the drafting of a correct action is of paramount importance; we therefore show the lift as it is accomplished in four different stages in a good action. Fig. 204 illustrates the engaging, and Fig. 205 the disengaging pallet; by comparing the

figures it will be noticed that the lift takes place on the point of the tooth similar to the English, until the discharging edge of the pallet has been passed, when the heel gradually comes into play on the engaging, but more quickly on the disengaging pallet.

We will also notice that during the first part of the lift the tooth moves faster along the engaging lifting plane than on the disengaging; on pallets 2 and 3 this difference is quite large; towards the latter part of the lift the action becomes quicker on the disengaging pallet and slower on the engaging.

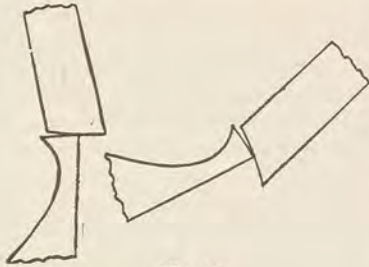

Fig. 206.

To obviate this difficulty some fine watches, notably those of A. Lange & Sons, have convex lifting planes on the engaging and concave on the disengaging pallets; the lifting planes on the teeth are also curved. See Fig. 206.

This is decidedly an ingenious arrangement, and is in strict accordance with scientific investigation. We should see many fine watches made with such escapements if the means for producing them could fully satisfy the requirements of the scientific principles involved.

The distribution of the lift on tooth and pallet is a very important matter; the lifting angle on the tooth must be *less* in proportion to its width than it is on the pallet. For the sake of making it perfectly plain, we illustrate what should not be made; if we have $10\frac{1}{2}^\circ$ for width of tooth and pallet, and take half of it for a tooth, and the other half for the pallet, making each of them $5\frac{1}{4}^\circ$ in width, and supposing we have a lifting of $8\frac{1}{2}^\circ$ to distribute between them, by allowing $4\frac{1}{4}^\circ$ on each, the lift would take place as shown in Fig. 207, which is a very unfavorable action. The edge of the engaging pallet scrapes on the lifting plane of the tooth, yet it is astonishing to find some otherwise very fine watches being manufactured right along which contain this fault; such watches can be stopped with the ruby pin in the fork and the engaging pallet in action, nor would they start when run down as soon as the crown is touched, no matter how well they were finished and fitted.



Fig. 207.

The lever lengths of the club tooth are variable, while with the ratchet they are constant, which is in its favor; in the latter it would always be as SB, Fig. 208. This is a shorter lever than QB, consequently more powerful, although the greater velocity is at Q, which

only comes into action after the inertia of wheel and pallets has been overcome, and when the greatest momentum during contact is reached. SB is the primitive radius of the club tooth wheel, but both primitive and *real* radius of the ratchet wheel. The distance of centers of wheel and pallet will be alike in both cases; also the lockings will be the same distance apart on both pallets; therefore, when horologists, even if they have worldwide reputations, claim that the club tooth has an advantage over the ratchet because it begins the lift with a shorter lever than the latter, it does not make it so. We are treating the subject from a purely horological standpoint, and neither patriotism or prejudice has anything to do with it. We wish to sift the matter thoroughly and arrive at a just conception of the merits and defects of each form of escapement, and show *reasons* for our conclusions.



Fig. 208.

Anyone who has closely followed our deductions must see that in so far as the wheel is concerned the ratchet or English wheel has several points in its favor. Such a wheel is inseparable from a wide pallet; but we have seen that a narrower pallet is advisable; also as little drop and lock as possible; clearly, we must effect a compromise. In other words, so far the balance of our reasoning is in favor of the club tooth escapement and to effect an intelligent division of angles for tooth, pallet and lift is one of the great questions which confronts the intelligent horologist.

Anyone who has ever taken the pains to draw pallet and tooth with different angles, through every stage of the lift, with both wide and narrow pallets and teeth, in circular and equidistant escapements, will have received an eye-opener. We strongly advise all our readers who are practical workmen to try it after studying what we have said. We are certain it will repay them.

THE CENTER DISTANCE OF WHEEL AND PALLETS.

The direction of pressure of the wheel teeth should be through the pallet center by drawing the tangents AC and AD , Fig. 197, to the primitive circle GH , at the intersection of the angle FBE . This condition is realized in the equidistant pallet. In the circular pallet, Fig. 198, this condition cannot exist, as in order to *lock* on a tangent the center distance should be *greater* for the engaging and *less* for the disengaging pallet, therefore watchmakers aim to go between the two and plant them as before specified at A .

When planted on the tangents the unlocking resistance will be less and the impulse transmitted under favorable conditions, especially so in the circular, as the direction of pressure coincides (close to the center of the lift) with the law of the parallelogram of forces,

It is *impossible* to plant pallets on the tangents in very small escapements, as there would not be enough room for a pallet arbor of proper strength, nor will they be found planted on the tangents in the medium size escapement with a long pallet arbor, nor in such a one with a very wide tooth (see Fig. 199) as the heel would come so close to the center A, that the solidity of pallets and arbor would suffer. We will give an actual example. For a medium sized escape wheel with a primitive diameter of 7.5 mm., the center distance AB is 4.33 mm. By using 3° of a lifting angle on the teeth, the distance from the heel of the tooth to the pallet center will be .4691 mm.; by allowing .1 mm. between wheel and pallet and .15 mm. for stock on the pallets we find we will have a pallet arbor as follows: $.4691 - (.1 + .15) \times 2 = .4382$ mm. It would not be practicable to make anything smaller.

It behooves us now to see that while a narrow pallet is advisable a very wide tooth is not; yet these two are inseparable. Here is another case for a compromise, as, unquestionably the pallets ought to be planted on the tangents. There is no difficulty about it in the English lever, and we have shown in our example that a judiciously planned club tooth escapement of medium size can be made with the center distance properly planted.

When considering the center distance we must of necessity consider the widths of teeth and pallets and their lifting angles. We are now at a point in which no watchmaker of intelligence would indicate one certain division for these parts and claim it to be "the best." It is always those who do not thoroughly understand a subject who are the first to make such claims. We will, however, give our opinion within certain limits. The angle to be divided for tooth and pallet is $10\frac{1}{2}^\circ$. Let us divide it by 2, which would be the most natural thing to do, and examine the problem. We will have $5\frac{1}{4}^\circ$ each for width of tooth and pallet. We *must* have a smaller lifting angle on the tooth than on the pallet, but the wider the tooth the greater should its lifting angle be. It would not be mechanical to make the tooth wide and the lifting angle small, as the lifting plane on the pallets would be too steep on account of being narrow. A lifting angle on the tooth which would be *exactly* suitable for a given circular, would be *too great* for a given equidistant pallet. It follows, therefore, taking $5\frac{1}{4}^\circ$ as a width for the tooth, that while we could employ it in a fair sized escapement with equidistant pallets, we could not do so with circular pallets and still have the latter pitched on the tangents. We see the majority of escapements made with narrower teeth than pallets, and for a very good reason.

In the example previously given, the 3° lift on the tooth is well adapted for a width of $4\frac{1}{2}^\circ$, which would require a pallet 6° in width. The tooth, therefore, would be $\frac{3}{4}$ the width of pallets, which is very good indeed.

From what we have said it follows that a large number of pallets are not planted on the tangents at all. We have never noticed this question in print before. Writers generally seem to, in fact do, assume that no matter how large or small the escapement may be, or how the pallets and teeth are divided for width and lifting angle no difficulty will be found in locating the pallets on the tangents. Theoretically there is no difficulty, but in practice we find there is.

EQUIDISTANT VS. CIRCULAR.

At this stage we are able to weigh the circular against the equidistant pallet. In the beginning we had to explain the difference between them, so the reader could follow our discussion, and not until now, are we able to sum up our conclusions.

The reader will have noticed that for such an important action as the lift, which supplies power to the balance, the circular pallet is favored from every point of view. This is a very strong point in its favor. On the other hand, the unlocking resistance being less, and as nearly alike as possible on both pallets in the equidistant, it is a question if the total vibration of the balance will be greater with the one than the other, although it will receive the impulse under better conditions from the circular pallet; but it expends more force in unlocking it. Escapement friction plays an important role in the position and isochronal adjustments; the greater the friction encountered the slower the vibration of the balance. The friction should be constant. In unlocking, the equidistant comes nearer to fulfilling this condition, while during the lift it is more nearly so in the circular. The friction in unlocking, from a timing standpoint, overshadows that of the impulse, and the tooth can be a little wider in the equidistant than the circular escapement with the pallet properly planted. Therefore for the *finest* watches the equidistant escapement is well adapted, but for anything less than that the circular should be our choice.

THE FORK AND ROLLER ACTION.

While the lifting action of the lever escapement corresponds to that of the cylinder, the fork and roller action corresponds to the impulse action in the chronometer and duplex escapements.

Our experience leads us to believe that the action now under consideration is but imperfectly understood by many workmen. It is a complicated action, and when out of order is the cause of many annoying stoppages, often characterized by the watch starting when taken from the pocket.

The action is very important, and is generally divided into impulse and safety action, although we think we ought to divide it into three, namely, by adding that of the unlocking action. We will first of all

consider the impulse and unlocking actions, because we cannot intelligently consider the one without the other, as the ruby pin and the slot in the fork are utilized in each. The ruby pin, or strictly speaking, the "impulse radius," is a lever arm, whose length is measured from the center of the balance staff to the face of the ruby pin, and is used, firstly, as a power or transmitting lever on the acting or geometrical length of the fork (*i. e.*, from the pallet center to the beginning of the horn), and which at the moment is a resistance lever, to be utilized in unlocking the pallets. After the pallets are unlocked the conditions are reversed, and we now find the lever fork, through the pallets, transmitting power to the balance by means of the impulse radius. In the first part of the action we have a short lever engaging a longer one, which is an advantage. See Fig. 209, where



Fig. 209.

we have purposely somewhat exaggerated the conditions. $A'X$ represents the impulse radius at present under discussion, and AW the acting length of the fork. It will be seen that the shorter the impulse radius, or in other words, the closer the ruby pin is to the balance staff and the longer the fork, the easier will the unlocking of the pallets be performed, but this entails a great impulse angle, for the law applicable to the case is, that the angles are in the inverse ratio to the radii. In other words, the shorter the radius, the greater is the angle, and the smaller the angle the greater is the radius. We know, though, that we must have as small an impulse angle as possible in order that the balance should be highly detached. Here is one point in favor of a short impulse radius, and one against it. Now, let us turn to the impulse action. Here we have the long lever, AW , acting on a short one, $A'X$, which is a disadvantage.

Here, then, we ought to try and have a short lever acting on a long one, which would point to a short fork and a great impulse radius. Suppose AP , Fig. 209, is the length of fork, and $A'P$ is the impulse radius; here, then, we favor the impulse, and it is directly in accordance with the theory of the free vibration of the balance, for, as before stated, the longer the radius the smaller the angle. The action at P is also closer to the line of centers than it is at W , which is another advantage.

We will notice that by employing a large impulse angle, and consequently a short radius, the intersection m of the two circles ii and cc is very safe, whereas, with the conditions reversed in favor of the impulse action, the intersection at k is more delicate. We have now seen enough to appreciate the fact that we favor one action at the expense of another.

By having a lifting angle on pallet and tooth of $8\frac{1}{2}^\circ$, a locking angle of $1\frac{1}{2}^\circ$, and a run of $\frac{1}{2}^\circ$, we will have an angular movement of the fork of $8\frac{1}{2} + 1\frac{1}{2} + \frac{1}{2} = 10\frac{1}{2}^\circ$.

Writers generally only consider the movement of the fork from drop to drop on the pallets, but we will be thoroughly practical in the matter. With a total motion of the fork of $10\frac{1}{2}^\circ$ (JAW, Fig. 210), one-half of $5\frac{1}{4}^\circ$ will be performed on each side of the line of centers. We are at liberty to choose any impulse angle which we may prefer; 3 to 1 is a good proportion for an ordinary well-made watch. By employing it the angle $XA'Y$ would be equal to $31\frac{1}{2}^\circ$. The radius $A'X$, Fig. 211, is also of the same proportion, but the angle $AA'X$ is greater because the fork angle WAA' is greater than the same angle in Fig. 210. We will notice that the intersection k is much smaller in

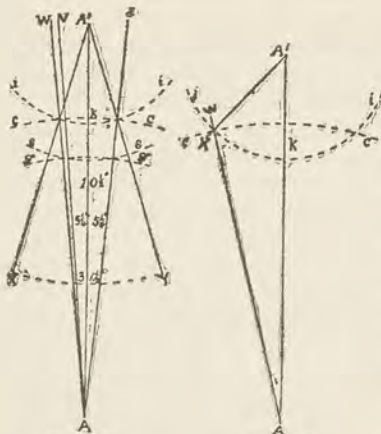

Fig. 210.

Fig. 211.

Fig. 210 than in Fig. 211. The action in the latter begins much further from the line of centers than in the former and outlines an action which should not be made. To come back to the impulse angle, some might use a proportion of 3.5, 4 or even 5 to 1, while others for the finest of watches would only use 2.75 to 1. By having a total vibration of the balance of $1\frac{1}{2}$ turns, which is equal to 540° , a fork angle of 10° and a proportion of 2.75 for the impulse angle which would be equal to $10 \times 2.75 = 27.5^\circ$. The free vibration of the balance, or as this is called, "the supplemental arc," is equal to $540^\circ - 27.5^\circ = 512.5^\circ$, while with a proportion of 5 to 1, making an impulse angle of 50° , it would be equal to 490° . To sum up, the finer the watch the lower the proportion, the closer the action to the line of centers, the smaller the friction. On account of leverage the more difficult the unlocking, but the more energetic the impulse when it does occur. The velocity of the ruby pin at P, Fig. 209, is much greater than at W, consequently it will not be overtaken as soon by the fork as at W. The velocity of the fork at the latter point is greater than at P; the intersection of ii and cc is also not as great; therefore the lower the proportion the finer and more exact must the workmanship be.

We will notice that the unlocking action has been overruled by the impulse. The only point so far in which the former has been favored

is in the diminished action before the line of centers, as previously pointed out at P, Fig. 209.

We will now consider the width of the ruby pin, and to get a good insight into the question, we will study Fig. 212. A is the pallet center, A' the balance center, the line AA' being the line of centers; the angle WAA' equals half the total motion of the fork, the other half, of course, takes place on the opposite side of the center line. WA is the center of the fork when it rests against the bank. The angle AA'X represents half the impulse angle; the other half, the same as with the fork, is struck on the other side of the center line. At the point of intersection of these angles we will draw *cc* from the pallet center A, which equals the acting length of the fork, and from the balance center we will draw *ii*, which equal the *theoretical* impulse radius; some writers use it as the *real* radius. The wider the ruby pin the greater will the latter be, which we will explain presently.

The ruby pin in entering the fork must have a certain amount of freedom for action, from 1 to $1\frac{1}{4}^\circ$. Should the watch receive a jar at the moment the guard point enters the crescent or passing hollow in the roller, the fork would fly against the ruby pin. It is important that the angular freedom between the fork and ruby pin at the moment it enters into the slot be *less* than the total locking angle on the pallets. If we employ a locking angle of $1\frac{1}{2}^\circ$ and $\frac{1}{2}^\circ$ run, we would have a total lock on the pallet of 2° . By allowing $1\frac{1}{4}^\circ$ of freedom for the ruby pin the moment the guard point enters the crescent, in case the fork should strike the face of the ruby pin, the pallets will still be locked $\frac{3}{4}^\circ$ and the fork drawn back against the bankings through the draft angle.

We will see what this shake amounts to for a given acting length of fork, which describes an arc of a circle, therefore the acting length is only the radius of that circle and must be multiplied by two in order to get the diameter. The acting length of fork = 4.5 mm., what is the amount of shake when the ruby pin passes the acting corner? $4.5 \times 2 \times 3.1416 \div 360^\circ = .0785 \times 1.25 = .0992$ mm. The shake of the ruby pin in the slot of the fork must be as slight as possible, consistent with perfect freedom of action. It varies from $\frac{1}{4}^\circ$ to $\frac{1}{2}^\circ$, according to length of fork and shape of ruby pin. A square ruby pin requires more shake than any other kind; it enters the fork and receives the impulse in a diagonal direction on the jewel, in which position it is illustrated at Z, Fig. 215. This ruby pin acts on a knife edge, but for all that the engaging friction during the unlocking action is considerable.

Our reasoning tells us it matters not if a ruby pin be wide or narrow, it must have *the same* freedom in passing the acting edge of the fork, therefore, to have the impulse radius on the point of intersection of A'X with AW, Fig. 212, we would require a *very* narrow ruby pin.

With 1° of freedom at the edge, and $\frac{1}{2}^\circ$ in the slot, we could only have a ruby pin of a width of $1\frac{1}{2}^\circ$. Applying it to the preceding example it would only have an actual width of $.0785 \times 1.5 = .1178$ mm., or the size of an ordinary balance pivot. At *z*, Fig. 212, we illustrate such a ruby pin; the theoretical and real impulse radius coincide with one another. The intersection of the circle *ii* and *cc* is very slight, while the friction in unlocking begins with 1° of half the total movement of the fork from the line of centers; to illustrate, if the angular motion is 11° the ruby pin under discussion will begin action $4\frac{1}{2}^\circ$ before the line of centers, being an engaging, or "uphill" friction of considerable magnitude.

The intersection with the fork is also much less than with the wider ruby pin, making the impulse action very delicate. On the other

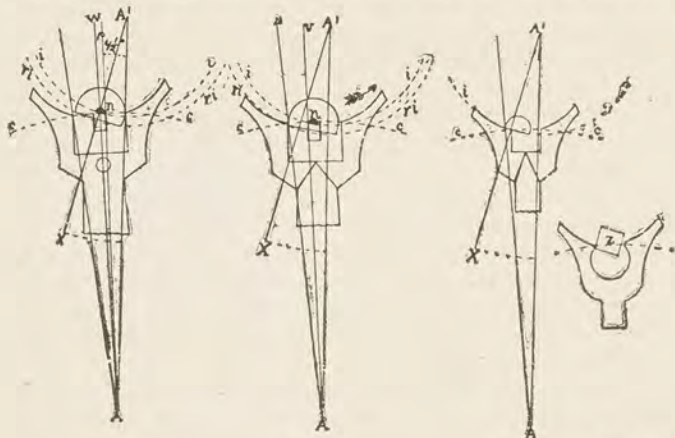

Fig. 212.

Fig. 213.

Fig. 214. Fig. 215.

hand the widest ruby pin for which there is any occasion is one beginning the unlocking action on the line of centers, Fig. 212; this entails a width of slot equal to the angular motion of the fork. We see here the advantage of a wide ruby pin over a narrow one in the unlocking action. Let us now examine the question from the standpoint of impulse action.

Fig. 213 illustrates the moment the impulse is transmitted; the fork has been moved in the direction of the arrow by the ruby pin; the escapement has been unlocked and the opposite side of the slot has just struck the ruby pin. The exact position in which the impulse is transmitted varies with the locking angle, the width of ruby pin, its shake in the slot, the length of fork, its weight, and the velocity of the ruby pin, which is determined by the vibrations of the balance and the impulse radius.

In an escapement with a total lock of $1\frac{3}{4}^\circ$ and $1\frac{1}{4}$ of shake in the slot, theoretically, the impulse would be transmitted 2° from the bankings. The narrow ruby pin z receives the impulse on the line v , which is closer to the line of centers than the line u , on which the large ruby pin receives the impulse. Here then we have an advantage of the narrow ruby pin over a wide one; with a wider ruby pin the balance is also more liable to rebank when it takes a long vibration. Also on account of the greater angle at which the ruby pin stands to the slot when the impulse takes place, the *drop* of the fork against the jewel will amount to more than its shake in the slot (which is measured when standing on the line of centers). On this account some watches have slots dovetailed in form, being wider at the bottom, others have ruby pins of this form. They require very exact execution; we think we can do without them by judiciously selecting a width of ruby pin between the two extremes. We would choose a ruby pin of a width equal to half the angular motion of the fork. There is an ingenious arrangement of fork and roller which aims to, and partially does, overcome the difficulty of choosing between a wide and narrow ruby pin; it is known as the Savage pin roller escapement. We intend to describe it later.

If the face of the ruby pin were planted on the theoretical impulse radius ii , Fig. 214, the impulse would end in a butting action as shown; hence the great importance of distinguishing between the theoretical and real impulse radius and establishing a reliable data from which to work. We feel that these actions have never been properly and thoroughly treated in simple language; we have tried to make them plain so that anyone can comprehend them with a little study.

Three good forms of ruby pins are the triangular, the oval and the flat faced; for ordinary work the latter is as good as any, but for fine work the triangular pin with the corners slightly rounded off is preferable.

English watches are met with having a cylindrical or round ruby pin. Such a pin should never be put into a watch. The law of the parallelogram of forces is completely ignored by using such a pin; the friction during the unlocking and impulse action is too severe, as it is, without the addition of so unmechanical an arrangement. Fig. 216 illustrates the action of a round ruby pin; ii is the path of the ruby pin; cc that of the acting length of the fork. It is shown at the moment the impulse is transmitted. It will be seen that the impact takes place *below* the center of the ruby pin, whereas it should take place at the center, as the motion of the fork is *upwards* and that of the ruby pin *downwards* until the line of the centers has been reached. The same rule applies to the flat-faced pin, and it is important that the right quantity be ground off. We find that $\frac{2}{3}$ is approximately the amount which should be ground away. Fig. 217

illustrates the fork standing against the bank. The ruby pin touches the side of the slot but has not as yet begun to act; ri is the real impulse circle for which we allow $1\frac{1}{4}^\circ$ of freedom at the acting edge of the fork; the face of the ruby pin is therefore on this line. The next thing to do is to find the center of the pin. From the side n of the slot we construct the right angle $on t$; from n we transmit $\frac{1}{2}$ the

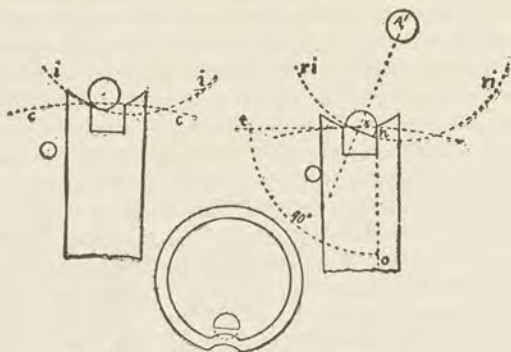

Fig. 216.

Fig. 218.

Fig. 217.

width of the pin, and plant the center x on the line $n t$. We can have the center of the pin slightly below this line, but in no case above it; but if we put it below, the pin will be thinner and therefore more easily broken.

THE SAFETY ACTION.

Although this action is separate from the impulse and unlocking actions, it is still very closely connected with them, much more so in the single than in the double roller escapement. If we were to place the ruby pin at X , Fig. 209, we could have a much smaller roller than by placing it at P . With the small roller the safety action is more secure, as the intersection at m is greater than at k . It is not as liable to "butt" and the friction is less when the guard point is thrown against the small roller. Suppose we take two rollers, one with a diameter of 2.5 mm., the other just twice this amount, or 5 mm. By having the guard radius and pressure the same in each case, if the guard point touched the larger roller it would not only have twice, but four times more effect than on the smaller one. We will notice that the smaller the impulse angle the larger the roller, because the ruby pin is necessarily placed farther from the center. The position of the ruby pin should, therefore, govern the size of the roller, which should be as small as possible. There should only be enough metal left between the circumference of the roller and the face of the jewel to

allow for a crescent or passing hollow of sufficient depth and an efficient setting for the jewel. For this reason, as well as securing the correct impulse radius and therefore angle, when replacing the ruby pin, and having it set securely and mechanically in the roller, it is necessary that the pin and the hole in the roller be of the same form and a good fit. Fig. 218 illustrates the difference in size of rollers. In the smaller one the conditions imposed are satisfied, while in the larger one they are not. In the single roller the safety action is at the mercy of the impulse and pallet angles. We have noticed that in order to favor the impulse we require a large roller, and for the safety action a small one, therefore escapements made on fine principles are supplied with two rollers, one for each action.

It may be well to say that in our opinion a proportion between the fork and impulse angles in 10° pallets of 3 or $3\frac{1}{2}$ to 1, depending upon the size of the escapement, is the lowest which should be made in single roller. We have seen them in proportions of 2 to 1 in single roller—a scientific principle foolishly applied—resulting in an action entirely unsatisfactory.

When the guard point is pressed against the roller the escape tooth must still rest on the locking face of the pallet; if the total lock is 2° , by allowing $1\frac{1}{4}^\circ$ freedom for the guard point between the bank and the roller the escapement will still be locked $\frac{3}{4}^\circ$. How much this shake actually amounts to depends upon the guard radius. Suppose this to be 4 mm., then the freedom would equal $4 \times 2 \times 3.1416 \div 360 \times 1.25 = .0873$ mm.

THE CRESCENT

The crescent in the roller must be large and deep enough so it will be impossible for the guard point to touch in or on the corners of it; at the same time it must not be too large, as it would necessitate a longer horn on the fork than is necessary.

Fig. 219 shows the slot *n* of the fork standing at the bank. The ruby pin *o* touches it, but has not as yet acted on it; *s* *s* illustrates a single roller, while *S* *2* illustrates the safety roller for a double roller escapement. In order to find the dimensions of the crescent in the single roller we must proceed as follows: *W* *A* is in the center of the fork when it rests against the bank, and is, therefore, one of the sides of the fork angle, and is drawn from the pallet center; *V* *A* *W* is an angle of $1\frac{1}{4}^\circ$, which equals the freedom between the guard point and the roller; *g* *g* represents the path of the guard pin *n* for the single roller, and is drawn at the intersection of *V* *A* with the roller. *A'* *A* *2* is a line drawn from the balance center through that of the ruby pin, and therefore also passes through the center of the crescent. By planting a compass on this line, where it cuts the periphery of the roller, and locating the point of intersection of *V* *A* with the

roller, will give us one-half the crescent, the remaining half being transferred to the opposite side of the line $A'A_2$. We will notice that the guard point has entered the crescent $1\frac{1}{4}^\circ$ before the fork begins to move.

The angle of opening for the crescent in the double roller escapement is greater than in the single, because it is placed closer to the balance center, and the guard point or dart further from the pallet center, causing a greater intersection; also the velocity of the guard point has increased, while that of the safety roller has decreased. Fig. 219, at ff , shows the path of the dart b , which also has $1\frac{1}{4}^\circ$ freedom between bank and roller. From the balance center we draw $A'd$ touching the center or point of the dart; from this point we construct at 5° angle $b A'd$. This is to insure sufficient freedom for the dart when entering the crescent. We plant a compass on the point of intersection of $A'A_2$ with the safety roller, S_2 , and locating the point where $A'b$

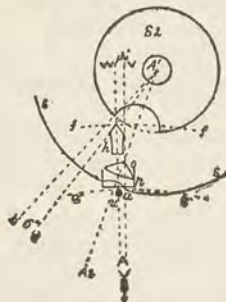

Fig. 219.

intersects it, have found one half the opening for the crescent, the remaining half being constructed on the opposite side of the line $A'A_2$.

THE HORN.

The horn on the fork belongs to the safety action; more horn is required with the double than with the single roller, on account of the greater angle of opening for the crescent. The horn should be of such a length that when the crescent has passed the guard point, the end of the horn should point to at least the center of the ruby pin.

The dotted circle, $s s$, Fig. 220, represents a single roller. It will be noticed that the corner of the crescent has passed the guard pin u by a considerable angle, and although this is so, in case of an accident the *acting edge* of the fork would come in contact with the ruby pin: this proves that a well made single roller escapement really requires but little horn, only enough to ensure the safe entry of the ruby pin in case the guard point at that moment be thrown against the roller. We will now examine the question from the standpoint of the double roller; S_2 , Fig. 220, is the safety roller; the corner of the crescent has

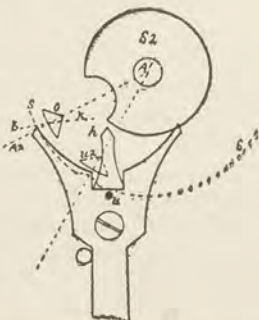

Fig. 220.

safely passed the dart h ; the centers of the ruby pin o and of the crescent being on the line $A'A_2$, we plant the compass on the pallet center and the center of the face of the ruby pin and draw $h'h$, which will be the path described by the horn. The end of the horn is therefore planted upon it from $1\frac{1}{2}^\circ$ to $1\frac{3}{4}^\circ$ from the ruby pin; this freedom at the end of the horn is therefore from $\frac{1}{4}^\circ$ to $\frac{1}{2}^\circ$ more than we allow for the guard point; it depends upon the size of the escapement and locking angles which we would choose. It must in any case be less than the lock on the pallets, so that the fork will be drawn back against the bank in case the horn be thrown against the ruby pin.

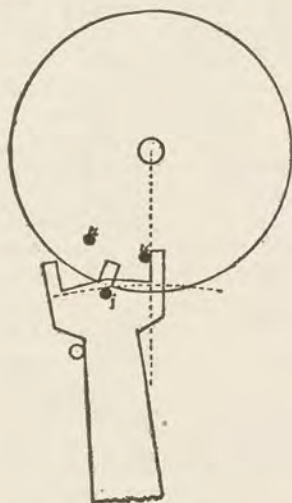

Fig. 221.

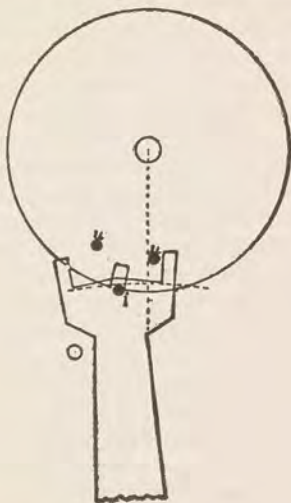

Fig. 222.

When treating on the width of the ruby pin, we mentioned the Savage pin roller escapement, which we illustrate in Figs. 221 and 222. This ingenious arrangement was designed with the view of combining the advantages of both wide and narrow pins and at the same time without any of their disadvantages.

In Fig. 221 we show the unlocking pins u beginning their action on the line of centers—the best possible point—in unlocking the escapement. These pins were made of gold in all which we examined, although it is recorded that wide ruby pins and ruby rollers have been used in this escapement, which would be preferable.

The functions of the two pins in the roller are simply to unlock the escapement; the impulse is not transmitted to them as is the case in the ordinary fork and roller action. In this action the guard pin i

also acts as the impulse pin. We will notice that the passing hollow in this roller is a rectangular slot, the same as in the ordinary fork. When the escapement is being unlocked the guard pin *z* enters the hollow and when the escape tooth comes in contact with the lifting plane of the pallet the pin *z*, Fig. 222, transmits the impulse to the roller.

The impulse is transmitted closer to the line of centers than could be done with any ruby pin. If the pin *z* were wider the impulse would be transmitted still closer to the line of centers, but the intersection of it with the roller would be less. It is very delicate as it is, therefore from a practical standpoint it ought to be made thin but consistent with solidity. If the pin is anyway large, it should be flattened on the sides, otherwise the friction would be similar to that of the round ruby pin. It would also be preferable (on account of the pin *z* being very easily bent) to make the impulse piece narrow but of such a length that it could be screwed to the fork, the same as the dart in the double roller. The impulse radius is also the radius of the roller, because the impulse is transmitted to the roller itself; for this reason the latter is smaller in this action than in the ordinary one having the same angles; also a shorter lever is in contact with a longer one in the unlocking than in ordinary action of the same angles; but for all this the pins *u u* should be pitched close to the edge of the roller, as the angular connection of the balance with the escapement would be increased during the unlocking action. This escapement being very delicate requires a 12° pallet angle and a proportion between impulse and pallet angles of not less than 3 to 1, which would mean an impulse angle of 36° ; this together with the first rate workmanship required are two of the reasons why this action is not often met with. George Savage, of London, England, invented this action.

The correct delineation of the lever escapement is a very important matter. We illustrate one which is so delineated that it can be practically produced. We have not noticed a draft of the lever escapement, especially with equidistant pallets and club teeth, which would act correctly in a watch.

A theorem is a proposition to be proved, not being able to prove it, we must simply change it according as our experience dictates, this is precisely what we have done with the escapement after having followed the deductions of recognized authorities with the result that we can now illustrate an escapement which has been thoroughly subjected to an impartial analysis in every respect, and which is theoretically and practically correct.

We will not only give instructions for drafting the escapement now under consideration, but will also make explanations how to draft it in different positions, also in circular pallet and single roller. We are convinced that by so doing we will do a service to many, we also

wish to avoid what we may call "the stereotyped" process, that is, one which may be acquired by heart, but introduce any changes and perplexity is the result. It is really not a difficult matter to draft escapements in different positions, as an example will show.

Before making a draft we must know exactly what we wish to produce. It is well in drafting escapements to make them as large as possible, say thirty to forty times larger than in the watch, in the present case the size is immaterial, but we must have specifications for the proportions of the angles. Our draft is to be the most difficult subject in lever escapements; it is to be represented just as if it were working in a watch; it is to represent a good and reliable action in every respect, one which can be applied without special difficulty to good watch, and is to be "up to date in every particular and to contain the majority of the best points and conclusions reached in our analysis.

SPECIFICATIONS FOR LEVER ESCAPEMENT.

The pallets are to be equidistant; the wheel teeth of the "club" form; there are to be two rollers; wheel, pallet, and balance centers are to be in straight line. The lock is to be $1\frac{1}{2}^\circ$, the run $\frac{1}{4}^\circ$, making a total lock of $1\frac{3}{4}^\circ$; the movement of pallets from drop to drop is to be 10° , while the fork is to move through $10\frac{1}{4}^\circ$ from bank to bank; the lift on the wheel teeth is to be 3° , while the remainder is to be the lift on the pallets as follows: $10\frac{1}{4} - (1\frac{3}{4} + 3) = 5\frac{1}{2}^\circ$ for lift of pallets.

The wheel is to have 15 teeth, with pallets spanning 3 teeth or $2\frac{1}{2}$ spaces, making the angle from lock to lock $= 360 \div 15 \times 2\frac{1}{2} = 60^\circ$, the interval from tooth to tooth is $360 \div 15 = 24^\circ$; divide by 2 pallets $= 24 \div 2 = 12^\circ$ for width of tooth, pallet and drop; drop is to be $1\frac{1}{2}^\circ$, the tooth is to be $\frac{3}{4}$ the width of the pallet, making a tooth of a width of $4\frac{1}{2}^\circ$ and a pallet of 6° .

The draw is to be 12° on each pallet, while the locking faces of the teeth are to incline 24° . The acting length of fork is to be equal to the distance of centers of scape wheel and pallets; the impulse angle is to be 28° ; freedom for dart and safety roller is to be $1\frac{1}{4}^\circ$, and for dart and corner of crescent 5° ; freedom for ruby pin and acting edge of fork is to be $1\frac{1}{4}^\circ$; width of slot is to be $\frac{1}{2}$ the total motion, or $10\frac{1}{4} \div 2 = 5\frac{1}{8}^\circ$; shake of ruby pin in slot $= \frac{1}{4}^\circ$, leaving $5\frac{1}{8} - \frac{1}{4} = 4\frac{7}{8}^\circ$ for width of ruby pin.

Radius of safety roller to be $\frac{1}{3}$ of the theoretical impulse radius. The length of horn is to be such that the end would point at least to the center of the ruby pin when the edge of the crescent passes the dart; space between the end of horn and ruby pin is to be $1\frac{1}{2}^\circ$.

It is well to know that the angles for width of teeth, pallets and drop are measured from the wheel center, while the lifting and lock-

ing angles are struck from the pallet center, the draw from the locking corners of the pallets, and the inclination of the teeth from the locking edge.

In the fork and roller action, the angle of motion, the width of slot, the ruby pin and its shake, the freedom between dart and roller, of ruby pin with acting edge of fork and end of horn are all measured from the pallet center, while the impulse angle and the crescent are measured from the balance center. A sensible drawing board measures 17 x 24 inches, we also require a set of good drawing instruments, the finer the instruments the better; pay special attention to the compasses, pens and protractor; add to this a straight ruler and set square.

The best all-round drawing paper, both for India ink and colored work has a rough surface; it must be fastened firmly and evenly to the board by means of thumb tacks; the lines must be light and made with a hard pencil. Use Higgins' India ink, which dries rapidly.

We will begin by drawing the center line $A' A B$; use the point B for the escape center; place the compass on it and strike $G H$, the primitive and geometrical circle of the escape wheel; set the center of the protractor at B and mark of an angle of 30° on each side of the line of centers; this will give us the angles $A B E$ and $A B F$ together, forming the angle $F B E$ of 60° , which represents from lock to lock of the pallets. Since the chord of the angle of 60° is equal to the radius of the circle, this gives us an easy means of verifying this angle by placing the compass at the points of intersection of $F B$ and $E B$ with the primitive circle $G H$; this distance must be equal to the radius of the circle. At these points we will construct right angles to $E B$ and $F B$, thus forming the tangents $C A$ and $D A$ to the primitive circle $G H$. These tangents meet on the line of centers at A , which will be the pallet center. Place the compass at A and draw the locking circle $M N$ at the points of intersection of $E B$ and $F B$ with the primitive circle $G H$. The locking edges of the pallets will always stand on this circle no matter in what relation the pallets stand to the wheel. Place the center of the protractor at B and draw the angle of width of pallets of 6° ; $I B E$ being for the engaging and $J B F$ for the disengaging pallet. In the equidistant pallet $I B$ is drawn on the side towards the center, while $J B$ is drawn further from the center. If we were drawing a circular pallet, one-half the width of pallets would be placed on each side of $E B$ and $F B$. At the points of intersection of $I B$ and $J B$ with the primitive circle $G H$ we draw the path O for the discharging edge of the engaging and P for that of the disengaging pallet. The total lock being $1\frac{3}{4}^\circ$, we construct $V' A$ at this angle from $C A$; the point of intersection of $V' A$ with the locking circle $M N$, is the position of the locking corner of the engaging pallet. The pallet having 12° draw when locked we place the center of the protractor on this corner and draw the

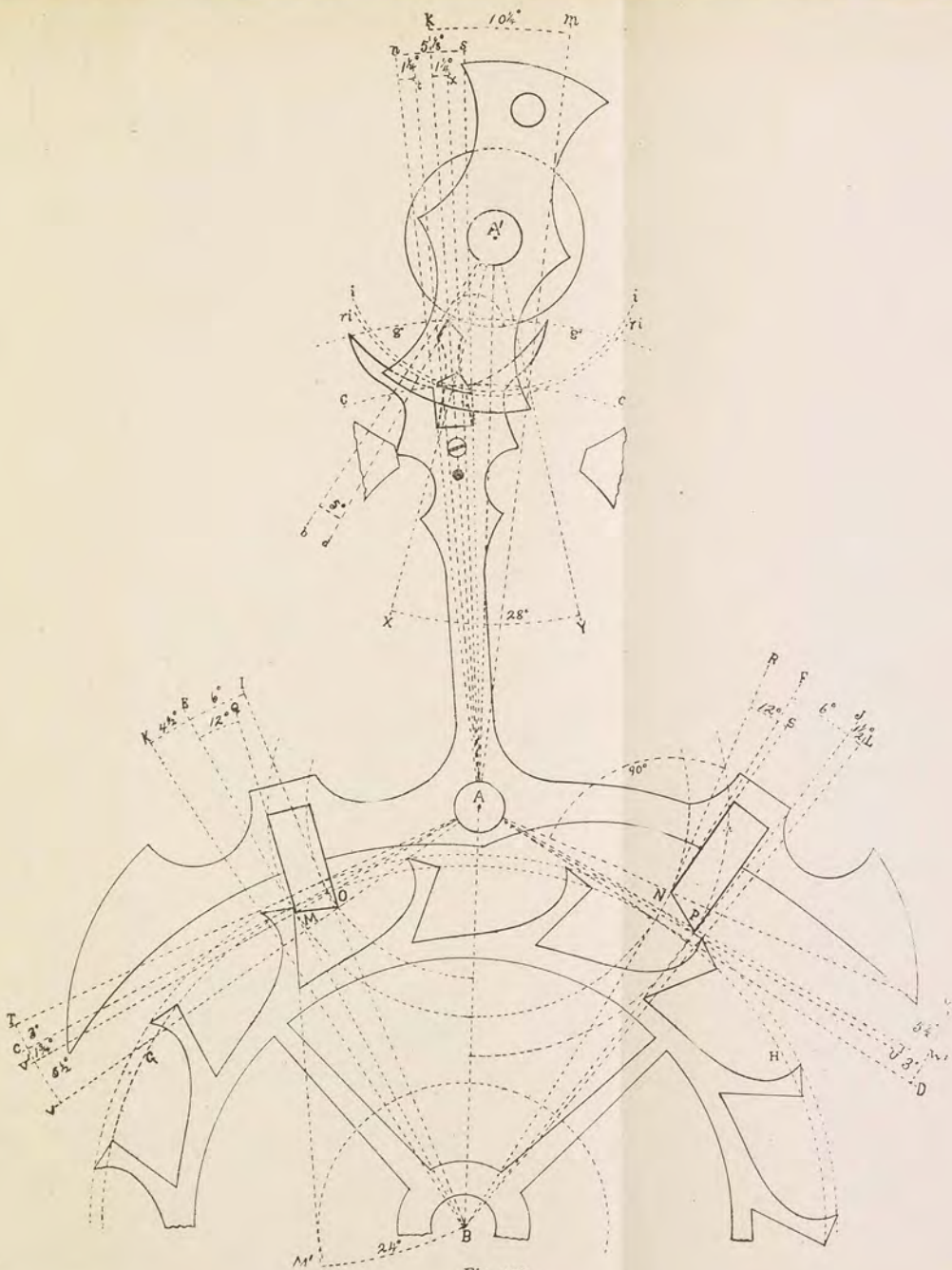

L

ir
co
ec

th
ru
fr
m
un
th
pa

we
th
wi

for
pr
of
the
tog
to
the
an
E
rac
E
tiv
wh
the
wit
alw
sta
the
anc
is d
fro
wid
the
we
for
con
V'
ner
we

angle $Q M E$. $Q M$ will be the locking face of the engaging pallet. If the face of the pallet were on the line $E B$ there would be no draw, and if placed to the opposite side of $E B$ the tooth would repel the pallet, forming what is known as the repellent escapement.

Having shown how to delineate the locking faces of the engaging pallet when locked, we will now consider how to draft both it and the disengaging pallet in correct positions when unlocked; to do so we direct our attention until further notice to Fig. 224. The locking faces $Q M$ of the engaging and $S N$ of the disengaging pallets are shown in dotted lines *when locked*. We must now consider the relation which the locking faces will bear to $E B$ in the engaging, and to $F B$ in the disengaging pallets when unlocked. This a question of some

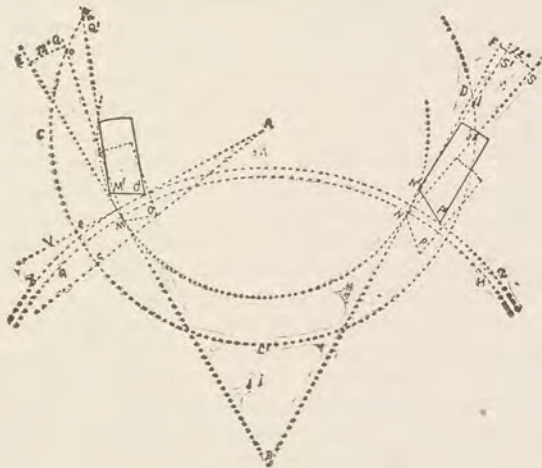

Fig. 224.

importance; it is easy enough to represent the 12° from the 30° angles when locked; we must be certain that they would occupy exactly that position and yet show them unlocked; we shall take pains to do so. In due time we shall show that there is no appreciable loss of lift on the engaging pallet in the escapement illustrated, the angle $T A V$ therefore shows the total lift; we have not shown the corresponding angles on the disengaging side because the angles are somewhat different, but the total lift is still the same. $G H$ represents the primitive circle of the escape wheel, and $X Z$ that of the real, while $M N$ represents the circular course which the locking corners of the pallets take in an equidistant escapement. At a convenient position we will construct the circle $C C' D$ from the pallet center A . Notice the

points e and c where VA and TA intersect in this circle; the space between e and c represents the extent of the motion of the pallets at this particular distance from the center A ; this being so, then let us apply it to the engaging pallet. At the point of intersection o the dotted line QM (which is an extended line on which the face of the pallet lies when locked), with the circle $CC'D$, we will plant our dividers and transfer ec to on . By setting our dividers on oM and transferring to nM' , we will obtain the location of $Q'M'$, the locking face when unlocked. Let us now turn our attention to the disengaging pallet. The dotted line SN represents the location of the locking face of the disengaging pallet when locked at an angle of 12° from FB . At the intersection of SN with the circle $CC'D$ we obtain the point j . The motion of the two pallets being equal, we transfer the distance ec with the dividers from j and obtain the point l . By setting the dividers on jN and transferring to lN' we draw the line $S'N'$ on which the locking face of the disengaging pallet will be located when unlocked. It will be perfectly clear to anyone that through these means we can correctly represent the pallets in any desired position.

We will notice that the face $Q'M'$ of the engaging pallet when unlocked stands at a greater angle to EB than it did when locked, while the opposite is the case on the disengaging pallet in which the angle $S'N'F$ is much less than SNF . This shows that the *deeper* the engaging pallet locks, the higher will the draw be, while the opposite holds good with the disengaging pallet; also, that the draw increases during the unlocking of the disengaging pallet. These points show that the draw should be measured with the *fork standing against the bank*, not when the locking corner of the pallet stands on the primitive circle, as is so often done. The recoil of the wheel (which determines the draw), is illustrated by the difference between the locking circle MN and the face QM for the engaging, and SN for the disengaging pallet, and along the *acting* surface it is alike on each pallet, showing that the draft angle should be the same on each pallet.

In both the equidistant and circular pallets the locking face SN of the disengaging pallet deviates more from the locking circle MN than does the locking face QM of the engaging pallet, as will be seen in the diagram. This is because the draft angle is struck from EB which deviates from the locking circle in such a manner, that if the face of a pallet were planted on it and *locked deep enough* to show it, the wheel would actually *repel* the pallet, whereas with the disengaging pallet if it were planted on FB , it would actually produce draw if locked very deep; this is on account of the natural deviation of the 30° lines from the locking circle. This difference is more pronounced in the circular than in the equidistant pallet, because in the former

we have two locking circles, the larger one being for the engaging pallet, and as an arc of a large circle does not deviate as much from a straight line as does that of a smaller circle, it will be easily understood that the natural difference before spoken of is only enhanced thereby. For this reason, in order to produce an *actual* draw of 12° , the engaging pallet may be set at a slightly greater angle from E B in the circular escapement; the amount depends upon the width of the pallets; the requirements are that the recoil of the wheel will be the same on each pallet. We must however repeat that one of the most important points is to measure the draw when the fork stands against the bank, thereby *increasing* the draw on the engaging and *decreasing* that of the disengaging pallet *during* the unlocking action, thus *naturally* balancing one fault with another.

We will again proceed with the delineation of the escapement here illustrated. After having drawn the locking face Q M, we draw the angle of width of teeth of $4\frac{1}{2}^\circ$, by planting the protractor on the escape center B. We measure the angle E B K, from the locking face of the pallet; the line E B does not touch the locking face of the pallet at the present point of contact with the tooth, therefore a line must be drawn from the point of contact to the center B. We did so in our drawing but do not illustrate it, as in a reduced engraving of this kind it would be too close to E B and would only cause confusion. We will now draw in the lifting angle of 3° for the tooth. From the tangent C A we draw T A at the required angle; at the point of intersection of T A with the 30° line E B we have the real circumference of the escape wheel. It will only be necessary to connect the locking edge of the tooth with the line K B, where the real or outer circle intersects it. It must be drawn in the same manner in the circular escapement; if the tooth were drawn up to the intersection of K B with T A, the lift would be too great, as that point is further from the center A than the points of contact are.

If the real or outer circle of the wheel intersects both the locking circle M N and the path O of the discharging edge at the points where T A intersects them, then there will be *no loss* of lift on the engaging pallet. This is precisely how it is in the diagram; but if there is any deviation, then the angle of loss must be measured on the *real* diameter of the wheel and not on the primitive, as is usually done, as the real diameter of the wheel, or in other words the heel of the tooth, forms the last point of contact. With a wider tooth and a greater lifting angle there will even be a *gain* of lift on the engaging pallet; the pallet in such a case would actually require a smaller lifting angle, according to the amount of gain. We gave full directions for measuring the loss when describing its effect in Fig. 203. Whatever the loss amounts to, it is added to the lifting plane of the pallet. In the diagram under discussion there is no loss, consequently the lifting angle

on the pallet is to be $5\frac{1}{2}^\circ$. From $V' A$ we draw $V A$ at the required angle; the point of intersection of $V A$ with the path O will be the discharging edge O . It will now only be necessary to connect the locking corner M with it, and we have the lifting plane of the pallet; the discharging side of the pallet is then drawn parallel to the locking face and made a suitable length. We will now draw the locking edges of the tooth by placing the center of the protractor on the locking edge M and construct the angle $B M M'$ of 24° and draw a circle from the scape center B , to which the line $M M'$ will be a tangent. We will utilize this circle in drawing in the faces of the other teeth after having spaced them off 24° apart, by simply putting a ruler on the locking edges and on the periphery of the circle.

We now construct $W' A$ as a tangent to the outer circle of the wheel, thus forming the lifting angle $D A W'$ of 3° for the teeth; this corresponds to the angle $T A C$ on the engaging side. $W' A$ touches the outer circle of the wheel at the intersection of $F B$ with it. We will notice that there is considerable deviation of $W' A$ from the circle at the intersection of $J B$ with it. At the intersecting of this point we draw $U A$; the angle $U A W'$ is the loss of lift. This angle must be added to the lifting angle of the pallets; we see that in this action there is no loss on the engaging pallet, but on the disengaging the loss amounts to approximately $\frac{7}{8}^\circ$ in the action illustrated. As we have allowed $\frac{1}{4}^\circ$ of run for the pallets, the discharging edge P is removed at this angle from $U A$; we do not illustrate it, as the lines would cause confusion being so close together. The lifting angle on the pallet is measured from the point P and amounts to $5\frac{1}{2}^\circ$ + the angle of the loss; the angle $W A U$ embraces the above angle besides $1\frac{1}{4}^\circ$ for run. If the locks are equal on each pallet, it proves that the lifts are also equal. This gives us a practical method of proving the correctness of the drawing; to do so, place the dividers on the locking circle $M N$ at the intersection of $T A$ and $V A$ with it, as this is the extent of motion; transfer this measurement to N , if the *actual* lift is the same on each pallet, the dividers will locate the point which the locking corner N will occupy *when locked*; this, in the present case, will be at an angle of $1\frac{3}{4}^\circ$ below the tangent $D A$. By this simple method, the correctness of our proposition that the loss of lift should be measured from the outside circle of the wheel, can be proven. We often see the loss measured for the engaging pallet on the primitive circumference $G H$, and on the real circumference for the disengaging; if one is right then the other must be wrong, as there is a noticeable deviation of the tangent $C A$ from the primitive circle $G H$ at the intersection of the locking circle $M N$; had we added this amount to the lifting angle $V' A V$ of the engaging pallet, the result would have been that the discharging edge O would be over 1° below its present location, thus showing that by the time the

lift on the engaging pallet had been completed, the locking corner N of the disengaging pallet would be locked at an angle of $2\frac{3}{4}^\circ$ instead of only $1\frac{3}{4}^\circ$. Many watches contain precisely this fault. If we wish to make a draft showing the pallets at any desired position, at the center of motion for instance, with the fork standing on the line of centers, we would proceed in the following manner: $10\frac{1}{4}^\circ$ being the total motion, one-half would equal $5\frac{1}{8}^\circ$; as the total lock equals $1\frac{3}{4}^\circ$, we deduct this amount from it which leaves $5\frac{1}{8} - 1\frac{3}{4} = 3\frac{3}{8}^\circ$, which is the angle at which the locking corner M should be shown above the tangent C A. Now let us see where the locking corner N should stand; M having moved up $5\frac{1}{8}^\circ$, therefore N moved down by that amount, the lift on the pallet being $5\frac{1}{2}^\circ$ and on the tooth 3° (which is added to the tangent D A), it follows that N should stand $5\frac{1}{2} + 3 - 5\frac{1}{8} = 3\frac{3}{8}^\circ$ above D A. We can prove it by the lock, namely: $3\frac{3}{8}^\circ + 1\frac{3}{4}^\circ = 5\frac{1}{8}^\circ$, half the remaining motion. This shows how simple it is to draft pallets in various positions, remembering always to use the tangents to the primitive circle as measuring points. We have fully explained how to draw in the draft angle on the pallets when unlocked, and do not require to repeat it, except to say, that most authorities draw a tangent R N, to the locking circle M N, forming in other words, the right angle R N A, then construct an angle of 12° from R N. We have drawn ours in by our own method, which is the correct one. While we here illustrate S N R at an angle of 12° it is in reality *less* than that amount; had we constructed S N at an angle of 12° from R N, then the draw would be 12° from F B, when the primitive circumference of the wheel is reached, but *more* than 12° when the fork is against the bank.

The space between the discharging edge P and the heel of the tooth forms the angle of drop J B I of $1\frac{1}{2}^\circ$; the definition for drop is that it is the freedom for wheel and pallet. This is not, strictly speaking, perfectly correct, as, during the unlocking action there will be a recoil of the wheel to the extent of the draft angle; the heel of the tooth will therefore approach the edge P, and the discharging side of the pallet approaches the tooth, as only the discharging edge moves on the path P.

A good length for the teeth is $\frac{1}{10}$ the diameter of the wheel, measured from the primitive diameter and from the locking edge of the tooth.

The backs of the teeth are hollowed out so as not to interfere with the pallets, and are given a nice form; likewise the rim and arms are drawn in as light and as neat as possible, consistent with strength.

Having explained the delineation of the wheel and pallet action we will now turn our attention to that of the fork and roller. We tried to explain these actions in such a manner that by the time we came to delineate them no difficulty would be found, as in our analysis we

discussed the subject sufficiently to enable any one of ordinary intelligence to obtain a correct knowledge of them. The fork and roller action in straight line, right, or any other angle is delineated after the methods we are about to give.

We specified that the acting length of fork was to be equal to the center distance of wheel and pallets; this gives a fork of a fair length.

Having drawn the line of centers $A' A$ we will construct an angle equal to half the angular motion of the pallets; the latter in the case under consideration being $10\frac{1}{4}^\circ$, therefore $5\frac{1}{8}^\circ$ is spaced off on each side of the line of centers, forming the angles $m A k$ of $10\frac{1}{4}^\circ$. Placing our dividers on $A B$ the center distance of scape wheel and pallets, we plant them on A and construct $c c$; thus we will have the acting length of fork and its path. We saw in our analysis that the impulse angle should be as small as possible. We will use one of 28° in our draft of the double roller; we might however remark that this angle should vary with the construction of the escapements in different watches; if too small, the balance may be stopped when the escapement is locked, while if too great it can be stopped during the lift; both these defects are to be avoided. The angles being respectively $10\frac{1}{4}^\circ$ and 28° it follows they are of the following proportions; $28^\circ \div 10.25 = 2.7316$. The impulse radius therefore bears this relation (but in the inverse ratio to the angles), to the acting length of fork.

We will put it in the following proportion: let Ac equal acting length of fork, and x the unknown quantity; $28:10.25::Ac:x$; the answer will be the theoretical impulse radius. Having found the required radius we plant one jaw of our measuring instrument on the point of intersection of cc with $k A$ or $m A$ and locate the other jaw on the line of centers; we thus obtain A' the balance center. Through the points of intersection before designated we will draft $X A'$ and $Y A'$ forming the impulse angle $X A' Y$ of 28° . At the intersection of this angle with the fork angle $k A' m$, we draw $i i$ from the center A ; this gives us the theoretical impulse circle. The total lock being $1\frac{3}{4}^\circ$ it follows that the angle described by the balance in unlocking = $1\frac{3}{4} \times 2.7316 = 4.788^\circ$. According to the specifications the width of slot is to be $5\frac{1}{8}^\circ$; placing the center of the protractor on A we construct half of this angle on each side of $k A$, which passes through the center of the fork when it rests against the bank; this gives us the angle $s A n$ of $5\frac{1}{8}^\circ$. If the disengaging pallet were shown locked then $m A$ would represent the center of the fork. The slot is to be made of sufficient depth so there will be no possibility of the ruby pin touching the bottom of it. The ruby pin is to have $1\frac{1}{4}^\circ$ freedom in passing the acting edge of the fork; from the center A we construct the angle $l A n$ of $1\frac{1}{4}^\circ$; at the point of intersection of $l A$ with $c c$, the acting radius of the fork, we locate the real impulse radius

and draw the arc $ri\ ri$, which describes the path made by the face of the ruby pin. The ruby pin is to have $\frac{1}{4}^\circ$ of shake in the slot; it will therefore have a width of $4\frac{7}{8}^\circ$; this width is drawn in with the ruby pin imagined as standing over the line of centers and is then transferred to the position which the ruby pin is to occupy in the drawing.

The radius of the safety roller was given as $\frac{1}{4}$ of the theoretical impulse radius. They may be made of various proportions; thus $\frac{3}{8}$ is often used. Remember that the smaller we make it, the less the friction during accidental contact with the guard pin, the greater must the passing hollow be, and the horn of fork and guard point must be longer, which increases the weight of the fork.

Having drawn in the safety roller, and having specified that the freedom between the dart and the safety roller was to be $1\frac{1}{4}^\circ$, the dart being in the center of the fork, consequently kA is the center of it; therefore we construct the angle kAX of $1\frac{1}{4}^\circ$. At the point of intersection of XA with the safety roller we draw the arc $g\ g$; this locates the point of the dart which we will now draw in. We will next draw in dA' from the balance center and touching the point of the dart; we now construct bA' at an angle of 5° to it. This is to allow the necessary freedom for the dart when entering the crescent; from A' we draw a line through the center of the ruby pin. We do not show it in the drawing, as it would be indiscernible, coming very close to $A'X$. This line will also pass through the center of the crescent. At the point of intersection of $A'b$ with the safety roller we have one of the edges of the crescent. By placing our compass at the center of the crescent on the periphery of the roller and on the edge which we have just found, it follows that our compass will span the radius of the crescent. We now sweep the arc for the latter, thus also drawing in the remaining half of the crescent on the other side of $A'X$ and bringing the crescent of sufficient depth that no possibility exists of the dart touching in or on the edges of it. We will now draw in the impulse roller and make it as light as possible consistent with strength. A hole is shown through the impulse roller to counterbalance the reduced weight at the crescent. When describing Fig. 219, we give instructions for finding the dimensions of crescent and position of guard pin for the single roller. We will find the length of horn: to do so we must closely follow directions given for Fig. 220. In locating the end of the horn, we must find the location of the center of the crescent and ruby pin *after* the edge of the crescent has passed the dart. From the point of intersection of $A'b$ with the safety roller we transfer the radius of the crescent on the periphery of the safety roller towards the side against the bank, then draw a line from A' through the point so found. At point of intersection of this line with the real impulse circle $ri\ ri$ we draw an arc radiating from the pallet center; the end of the horn will be located

on this arc. In our drawing the arc spoken of coincides with the dart radius gg . As before pointed out, we gave particulars when treating on Fig. 220, therefore considered it unnecessary to further complicate the draft by the addition of all the constructional lines. We specified that the freedom between ruby pin and end of horn was to be $1\frac{1}{2}^\circ$; (these lines, which we do not show) are drawn from the pallet center. Having located the end of the horn on the side standing against the bank, we place the dividers on it and on the point of intersection of kA with gg —which in this case is on the point of the the dart,—and transfer this measurement along gg which will locate the end of the horn on the opposite side.

We have the acting edges of the fork on cc and have also found the position of the ends of the horns; their curvature is drawn in the following manner: We place our compasses on A and ri , spanning therefore the real impulse radius; the compass is now set on the acting edge of the fork and an arc swept with it which is then to be intersected by another arc swept from the end of the horn, on the same side of the fork. At the point of intersection of the arcs the compass is planted and the curvature of the horn drawn in, the same operation is to be repeated with the other horn. We will now draw in the sides of the horn of such a form that should the watch rebank, the side of the ruby pin will squarely strike the fork. If the back of the ruby pin strikes the fork there will be a greater tendency of breaking it and injuring the pivots on account of acting like a wedge. The fork and pallets are now drawn in as lightly as possible and of such form as to admit of their being readily poised. The banks are to be drawn at equal distances from the line of centers. In delineating the fork and roller action in any desired position, it must be remembered that the points of location of the real impulse radius, the end of horn, the dart or guard pin and crescent, must *all* be obtained *when standing against the bank*, and the arcs drawn which they describe; the parts are then located according to the angle at which they are removed from the banks.

A Problem in the Lever Escapement. Among the problems of the detached lever escapement which often cause confusion, we wish to mention one in which the effect is that the actual lock, at the moment when the escape tooth drops on the locking plane, is different on each pallet, whereas it ought to be alike, in so far as angular lock is concerned. As regards the lock by linear measurement, in equidistant pallets, it is to be alike on each pallet, but, theoretically, not so in the circular pallet, as in the latter there are two locking circles, the larger one for the engaging and the smaller one for the disengaging pallet. If the angular lock in such pallet were alike, the linear lock would not be so. It would be greater on the engaging pallet, the difference

depending on the width of the pallets; the wider they are, the greater is the difference.

It is a common practice to make the linear lock alike on each pallet, which has the effect of diminishing the locking angle on the engaging pallet, as it locks on the longer lever. This certainly diminishes the friction during unlocking on the pallet, which causes the greater resistance. On the other hand, the locking angle is decreased by *increasing* the lifting angle on the engaging pallet, thus creating greater friction during the lifting action.

Having made these necessary explanations regarding the lock, we will now consider the effect described in our opening lines. Suppose we examine an escapement in which we find that the actual lock on the disengaging is much greater than on the engaging pallet. There can only be one cause for it, and that is, the lifting angles are dissimilar on the pallets, and no amount of shifting them in or out, or of altering their angular connection with the fork, will make any difference in the relative locking angles. There is but one remedy, and that is to grind the lifting plane of one of the pallets to the required angle.



Fig. 225.

Which one are we to grind, and how are we to do it? The answer to the first question is, we can grind either one, as an examination of Fig. 225 will show. If we grind the disengaging pallet off to the dotted line *N P*, we will decrease the lock on it. Not having altered

the discharging edge *P*, it follows that the lock on the engaging pallet has not been altered. On the other hand, if we grind the engaging pallet to the dotted line *M O*, it will be discharged earlier, thus making the lock on the disengaging pallet so much lighter; in the first case, then, increasing the lifting angle, in the latter, decreasing it.

We could also lessen the lift on one and increase it on the other, but it would be senseless to grind two pallets, if the proper effect can be obtained by grinding only one. Intelligent investigation will show which one to grind. As a cardinal principle, the lifting angles should be as small as possible. In a movement of good quality we can successfully employ a smaller angle than in one of low quality. This is the idea to be kept in view, but we will now expatiate upon it.

Before deciding to decrease the lift on the engaging pallet, the lifting angles must be closely examined when in action. If it is such that no light may be seen between the lifting plane of the pallet and heel of the tooth when the latter stands even with the locking edge of the pallet, then the lift must not be decreased. Were we to do so, the action would take place under adverse circumstances, as shown in

Fig. 226. Further, when the lift on the engaging pallet is decreased then the inside drop is decreased as well; on the other hand, if the disengaging lift is decreased the outside drop will be slightly decreased, but not nearly as much as when the change is made on the engaging pallet. If the lift be increased on either pallet no change in the drop will occur, and no change will be made in the run, whereas if the lift be decreased then the run of the pallets to the banks after the drop has occurred, will be increased, and that, too, on the pallet which was not altered. Depending upon the more or less accurate construction of the escapement, it may or may not necessitate altering the angular connection of the pallets on the fork, or the "let off," as this is called, so as to equalize the run. A closer banking will also be required. This will alter the freedom of the ruby pin when passing the acting edge of the fork and place the guard point closer to the roller.

If this particular alteration, that is, decreasing the lift, is made on a pallet with fork in one piece, either the fork itself must be slightly deflected, which is preferable, or the pallet which was ground off pulled out a trifle and the other one moved back a corresponding amount. As to the effect of these changes, depending upon the constructional faults, we may bring the pallets nearer to the theoretical requirements or tend to annihilate them, therefore we must observe that an accurate knowledge of all the functions of the escapement are necessary, if we would intelligently



Fig. 226.

make a change. There are so many apparently natural operations which would destroy the theoretical advantages of certain constructions, and though the timepiece may give fair service to a person, whose requirements are not of the most exacting, it would be rendered unfit for accurate timing under those conditions.

Having studied these points, the workman must decide by the particular escapement under his notice as to whether there is to be a decrease or an increase of lift.

To the second question, how are we to do it? The diamond laps for grinding are usually made of either copper or of soft steel. For this kind of a job we prefer the latter. Take a piece of soft steel about one and a half inches in diameter and at least one-sixteenth thick; bore a hole through the center of it to exactly fit the arbor chuck of the lathe, turn it up true in round and flat, then stone on both sides on a soft, flat cast-iron block, with oil-stone dust and oil until smooth. For charging the lap we require a dead hard steel roller about one-half inch long by one-quarter of an inch in diameter. Through the center of it there is to be a good sized hole, through which a steel pin passes freely. The roller is held by the pin in a frame which is mounted in a stout handle.

Properly graded diamond dust may be procured from material dealers. It is sold in five grades. For general work use No. 3 for grinding and No. 5 for the polishing.

To charge the lap, take a small quantity of the powder, mix to a stiff paste with thick oil and thoroughly roll it into the lap, resting the latter on a solid surface while doing so. To remove the oil, clean in benzine or alcohol. The lap for polishing should be of ivory and mounted in the same manner. The polishing powder is too fine to be rolled into the lap, so it will only be necessary to apply a small quantity mixed with oil to it. Water is generally applied to the lap when grinding stone, and oil in grinding hard steel.

A method for holding the pallets which is suitable for the general workman is to fix them in the tool holder of the slide rest. To do so

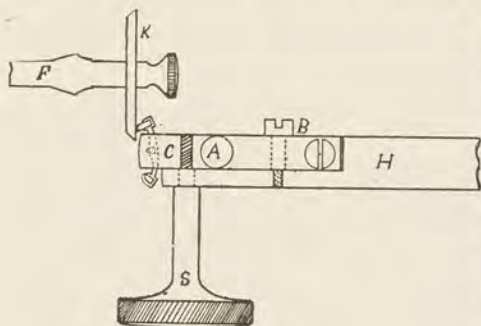

Fig. 227.

we require a little tool of which we show a plan in Fig. 227, and a side view in Fig. 228. *H* is a piece of steel of the form of the shank of the slide rest cutter. *D*, Fig. 228, is a steel table pivoted on it, by the shoulder screw *S*. *C* is a heavy spring screwed to the table *D*. *A* is a set screw for deflecting

the spring *C*. The pallets are placed on the table *D*, the spring *C* is then clamped on them by means of the screw *A*. *E* is a circular groove in the table *D*. *B* is a set screw with threads in the holder *H*. By means of the latter screw the table *D* may be bound rigidly to *H*, or by slightly loosening it and working the milled screw head *S*, the table may be given a circular motion bounded by the banking of the ends of the groove *E*, on the screw *B*. It is important that the center of the screw *S* should coincide with the center of a pallet of ordinary thickness, when the latter is clamped on the table *D*. Suppose now, we intend decreasing the lift on the engaging pallet. They are to be clamped as shown in Fig. 227 with the shank *H* put into position in the tool holder of the slide rest. *K*, Fig. 227, is the diamond lap in position on the arbor chuck *F* which is mounted in the lathehead.

The tool holder, or the upper slide, is set at the angle desired, so that when the discharging edge *O* of the pallet touches the lap, the light between the latter and the locking edge *M* will equal the amount to be ground off. In grinding, a very light pressure only must be

applied, the sound being our guide. Under no circumstances must the lap be allowed to get dry, and both lap and traverse slide must be kept in motion. Particular attention must be paid to these points, otherwise success will be out of the question.

If the pallet is to be flat on the face it is held parallel to the lap through the set screw *B*. If, on the other hand, it is to have a rounded or convex face, the set screw *B* is loosened and a circular motion imparted to the pallet by slowly moving the screw *S* back and forth with

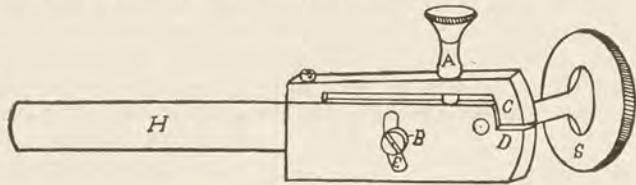

Fig. 228.

one hand while the other is employed moving the traverse slide. The face of the pallet must nearly be ground off to the edge *M*; it is intended that the polishing should bring it up to it. When through grinding, we replace the steel lap by the ivory polishing lap which we charge as directed. We proceed the same as in grinding. When polished, the pallets are removed and thoroughly cleaned before being replaced in the watch.

What we have here said is also applicable to the Graham anchor for clocks.—*Playtner*.

A Lever Escapement Fault. This is what is called mismatched pallets and escape wheel. In the club tooth this error is very fatal to good rate and is about as represented in Fig. 230. With the escapement at its best the friction is very little, but to maintain it constant is of the greatest importance. Now, to thoroughly explain the fault above mentioned it is necessary to first state it and then call attention to the illustrations. This error is the relative pitch or slant of the impulse plane of the tooth and the pallet. When in a perfect relation, as in Fig. 229, the tooth gets onto the impulse plane of



Fig. 229. Fig. 230.

the pallet, with its front corner touching the pallet's plane and so moves about two-thirds of the way across, with only the corner touching, then as it proceeds, the whole face of the tooth touches the plane, shortly after the front corner has left the plane, and thus the escapement is made. With the faulty escapement, as in Fig. 230, the pallet's front corner gets onto the impulse plane of the tooth and thus proceeds a

part of the way before the correct relation begins. Now when, as in the first case, the tooth rides over pallet with its corner, the corner of the tooth cannot cut the plane of the pallet, as the metal will not act on the stone; but as in the second case, when the pallet's corner gets onto the plane of the tooth and so proceeds, the pallet corner will wear the face of the tooth, as the stone will cut the soft metal. This fault is present in a more or less degree in many escapements with the club tooth, and when a watch gives trouble by failing to keep its rate after cleaning, as soon as the oil is the least dry on pallets, it argues that this fault may be looked for. The illustrations of the two actions are purposely exaggerated to clearly illustrate the points under treatment.

LOCKING. The amount the escape tooth overlaps the pallet at the time it leaves the impulse face. The part where the escape tooth strikes the pallet.

MAGNETISM. The agent or force in nature which gives rise to the phenomena of attraction, polarity, etc., exhibited by the loadstone, magnet, etc. A watch will become magnetized by too close proximity to a powerful magnetic field, such as is developed in a dynamo electro machine, for producing electric light, or by coming in contact with an ordinary magnet, as well as other sources of magnetic or electro-magnetic influences, and by these means all its steel parts become permanent magnets. Each piece of steel has then assumed definite polarity, so that if it is balanced on a point like a compass, it will, like the latter, indicate the direction of the earth's magnetic poles. The influence of these separate magnets, one on the other, and the influence of the earth's magnetism on the different parts, become very potent disturbers of time, keeping. Hairsprings, balances, and other small steel parts often become magnetized through being handled with magnetized tweezers or being placed near or in contact with other steel tools that have been magnetized.

Mr. B. Frese exemplifies the influence of the separate magnets produced in a watch by its parts becoming magnetized as follows: if we take two compasses and place them side by side, so that the two bearing points of the needles will form a right angle to their direction, neither of them will show any variation from their natural position or the position they are compelled to take by the influence of the earth's magnetism; but by moving one a little to the North or South of this position, we notice a deflection in both, which is caused by the poles of unequal names having been brought near to each other. Besides this main disturbing influence upon accurate time keeping, we must also consider the disturbance caused by direct attraction, which takes place by two magnetized parts when their equal, as well as their unequal, polarities come close together, but when two extremities of equal polarity come close together or in contact, the stronger magnetized piece will cause the weaker to

assume its own polarity, so that when the South polarity of a strongly magnetized piece is brought in contact with the South polarity of a weaker, the South of the latter will be changed to North, and the North to South when the two North polarities have been in contact. The largest steel parts in a watch are the mainspring and the case springs, and these are, therefore, the most potent to cause a disturbance in a steel or compensation balance, aside from the earth's magnetism; the balance being the medium by which nearly all the disturbance is caused, as during its vibrations it makes different positions to the polarities of the other steel parts, as well as the earth's polarities, which is the greatest disturber, aside from the mainspring, the polarities of which change in relation to the balance as the watch runs down. The force one magnetized piece exerts on the other multiplies with decreased distance. The fork, pallets and 'scape wheel are too small in bulk to cause much disturbance, either by direct attraction or directive force, unless they are charged to saturation, which very seldom occurs. If a magnetized balance is placed on a poising tool, with the staff in North and South direction, it will appear out of poise, caused by the earth's magnetism, and will maintain its North polarity uppermost. If it is placed in an East direction, it will no longer allow the North polarity to remain uppermost, but will cause the same to move toward the North and indicate the magnetic dip, the amount of which varies in the different latitudes of the globe. If we place the balance in a horizontal position, its north and South polarities will coincide with those of a compass, showing that if the balance were the only part magnetized in a watch, that magnetism causes more complicated variations than a balance out of poise to the same extent. That trying to poise a magnetized balance would be useless, is self-evident, for the reason that in a horizontal and North and South position, no equilibrium can be obtained. The influence of magnetized parts that do change position in a watch, is a constant one, as long as the size of vibration is maintained, and is, therefore, not the cause of serious disturbance. The substituting of new case springs will, therefore, be of little or no benefit.

To detect magnetism, place a pocket compass upon a show case, and place the watch to be operated upon on the table and close to the compass, and to the East and West of it. Before starting the test, stop the watch, and keep it from running by inserting a wedge made from a thin slip of paper beneath the balance. Turn the compass box around until the needle points to zero, before approaching the watch to it. Having placed the watch to the East or West of the compass, proceed to turn the movement, presenting first one figure of the dial and then another to the compass, and at the same time noting the deflection of the compass needle. Note whether the deflection is towards the East or West, i. e., whether it repels or attracts the needle. If the movement is not magnetized, the compass needle will remain stationary. If it is magnetized,

the needle will be deflected, and by noting the spot, you can very readily detect the magnetized part. Magnetism may be removed from small steel parts by placing them in the lathe and revolving them rapidly, and at the same time approaching them with a horseshoe magnet, and then gradually withdrawing the magnet. It is not good policy, however, to place any magnetized piece in your lathe, as you are liable to magnetize chucks, and they will cause you no end of trouble in the future. Demagnetizers are now to be purchased so cheaply that it will scarcely pay you to experiment with home made substitutes. See *Demagnetizer*.

To Demagnetize Watches. As watches only become magnetized by being brought into too close contact with magnets, dynamos, and the like, it is an utter waste of time to try and demagnetize them by applying heat or cold, or rubbing on decoctions of various kinds. Magnetic influence is the only remedy for the evil. The application of the remedy is effected in various ways. If we suspect that a watch is magnetized, the first thing to do is to prove it. It is well to try all watches for magnetism before starting on repairs, and this can be done in the presence of the customer. Place a fair sized pocket compass on, or gummed to the under side of your show case glass, in such a position that when at rest the needle will point to O. Place the watch a little to the East or West of the compass and revolve it slowly, watching the needle of the compass to see if the needle is deflected. Be careful to keep the centers of the watch and compass at a given distance apart. If magnetized, the needle of the compass will deflect to the right and left as the watch is revolved. Note the deflection at a given point, and then proceed to revolve. In this way you can closely approximate the location of the affected part. By taking the movement apart you can in the same manner readily determine the affected part or parts, and they can be demagnetized without much difficulty. All of the steel parts of a watch, except the balance and spring, can be readily demagnetized in the following manner: Place a bar magnet upon a piece of white paper, previously marked with lines, say one-eighth of an inch apart. Lift the affected part with a pair of brass or non-magnetic tweezers, and approach one end of it within one-eighth of an inch of the magnet, then reverse and approach the opposite end to within one-fourth of an inch; reverse and approach first end to within three-eighths of an inch, and so on until you reach a distance where the magnet exerts no influence. Test your piece, as previously described, with a compass, and if the cure is not effected, repeat the operation. The circular form of the balance renders it somewhat more difficult to treat successfully, and it is best demagnetized as follows: Fasten the balance on a large cork, say from one and a half to two inches in diameter, by means of a small brass pin bent at right angles, and mount the cork in your lathe and revolve. Take a ten-inch compound magnet and approach it as closely to the balance as possible,

and then gradually withdraw the magnet, keeping the balance revolving meanwhile, thus presenting every portion of it to the influence of the magnetic force. In some cases it will be found impossible to demagnetize the balance, although the operation may be repeated many times. A close examination and test of the balance by means of a compass will show that each arc of the balance has a positive and negative end, and the cross-bar will be found in the same condition. Under such circumstances it is absolutely unnecessary to thoroughly magnetize the balance by applying it to the magnet. You can demagnetize it, as previously described, without difficulty. It is advisable not to use your regular lathe in this operation, but rather to use some old lathe, or a polishing lathe will be found very desirable. See *Demagnetizer*.

MAINSRING. The ribbon of steel which serves to produce the motive power for a watch, chronometer, or clock. It is said to be the invention of Peter Hele, a clockmaker of Nuremberg, about the year 1500.

It would appear that the mainspring, when first applied to the watch, was not enclosed in a barrel, but the outer end of the spring was bent into the form of a hook and fixed to a winding arbor, together with a ratchet wheel and click. A guard was attached to one of the plates in order to check the outer coil of the spring and prevent it expanding too far. The inner end was made fast to the axis of the great wheel, consequently it was wound up from the center. The re-expansion set the train in motion.

The motive force due to the tension of a spring is more or less variable. The causes of this want of uniformity, says Saunier, are as follows: The elastic reaction of a spring becomes greater as the spring is further wound up. A metallic blade is very rarely homogeneous, and worked with sufficient care to avoid different parts being of variable strength. Its energy alters with time dependent on the duration and intensity of the flexure, and this change nearly always occurs irregularly throughout its length. Its elastic force diminishes slightly on elevating the temperature, and lastly, a spring rubs against the bottom and lid of the barrel in uncoiling. The successive coils also adhere and rub together, either permanently or occasionally. All these resistances are from the nature of the case variable.

Various forms of mainsprings have been adopted from time to time. The cylindrical spring was one in which the central coils were made thicker with a view to diminish the differences in the pull of the spring when wound up to varying degrees, and to increase its energy when nearly run down. The spring, when fully wound up, rubbed together in the central coils, so that the motive force when it was fully wound was neutralized by the friction. These springs are very rarely seen now, as they were expensive to manufacture, and the advantages they possessed

were more apparent than real. The taper spring was another form, which is rarely seen now. The thickness of the metal in these springs, gradually diminished throughout its entire length, the effect being to make the coils, when fully wound up, separate, and on this account the spring developed freely. This form was abandoned on account of the cost of manufacture. The third form is the ordinary spring in use to-day, the thickness of whose coils is the same throughout. The development is less uniform than with the tapered spring, as is also the separation of the coils, but it is cheaper of construction, and the variations do not exceed the limits that ordinary escapements can neutralize.

M. M. Roze, in a work on the mainspring, lays down and demonstrates the following theorems:

1. *A mainspring in the act of uncoiling in its barrel, always gives a number of turns equal to the difference between the number of coils in the up and down positions.*

For example, if 17 is the number of coils when the spring is run down, and 25 is the number when against the arbor, the difference between 17 and 25 or 8, will represent the number of turns in the uncoiling.

2. *With a given barrel, spring and arbor, in order that the number of turns may be a maximum, it is necessary that the length of the spring be such that the occupied part of the barrel, (exclusive of that filled by the arbor), be equal to the unoccupied part; in other words, the surface covered by the spring when up or down must be equal to the uncovered surface of the barrel bottom.*

The diameter of the arbor is not an arbitrary quantity, as it depends on the duration of flexure and thickness of the spring, and this depends greatly on the quality of the metal; if it is too small, it is liable to rupture the spring and deprive it of part of its elastic reaction, and if too large, part of this reaction will be wasted. M. Roze demonstrated that the thickness of the spring should be to the diameter of the arbor as 1:26 or 34, according as the rotation of the barrel takes place more or less rapidly. For example, 1:26 is best suited to watches; 1:30 for chronometers; and 1:34 for clocks or time pieces that are expected to go for longer periods.*

Until within a very few years mainsprings were made by a method that had been in use, and never improved on, for years.

About 1885 the American Waltham Watch Company secured the services of foreman Logan, who for years had been engaged in making hairsprings, and was about to carry out a scheme for making mainsprings, which he had long experimented upon and secured patents on.

At the outset, Mr. Logan forsook the old methods of manufacturing springs, and adopted new and novel ways of producing better results at

*If the reader is desirous of studying the subject at length, he is referred to Saunier's *Modern Horology*, pp. 661 to 671 inclusive, and a *Simple and Mechanically Perfect Watch*, by Moritz Grossman. Geo. K. Hazlitt & Co., Chicago.

less cost. The experiments necessary to such a radical change were costly, but the improvement in the quality and finish of the springs was so gratifying that mechanical appliances in great variety have from time to time been put to work, so that to-day the product is double that of two years ago, while the number of employes necessary is about one-half, owing to automatic machinery.

The steel used is manufactured expressly for springs, and comes in strips varying in length from one hundred to five hundred feet. As may well be supposed the best quality of steel adapted for the peculiar demands of a first-class watch mainspring was not found without much trouble, experimenting and expense. Steel made in England, France, Belgium, and this country were tried. After a series of trials, just the kind of steel desired was obtained. This steel is run through a machine which cuts it into numerous narrow ribbons, of widths suitable for the particular size of spring desired.

These ribbons are simultaneously wound upon bobbins, and are next passed, individually, through specially designed rolls, to bring the steel to a more exact and uniform thickness than can possibly be obtained from steel makers.

The next operation is that of rounding the edges, which is done by a new and unique machine. Following this the flat sides are ground and polished.

Up to this point the steel is in the untempered condition in which it is received at the factory. Hardening and tempering is next in order; these operations are performed by new methods which are almost automatic.

One of the elements which contributes largely to the very successful treatment of the steel in this important but delicate part of spring making is that of the fuel used for heating. In the earlier days of the manufacture a great variety of fuel was tried, but nothing has been found to equal the carefully purified water gas, which is now used.

Next in order the finishing polish is put on the sides and edges of the ribbons. Next the ribbons are cut up into exact lengths for individual springs. The ends are then annealed, preparatory to the punching for the reception of the barrel arbor hook and the tip. After punching follows coiling, when any faults in tempering are made apparent. If the steel has been overheated the severe strain of coiling will cause it to break. Failure to draw the temper sufficiently low will produce the same result, while too low a temper will cause them to "set," and thereby indicate their worthlessness.

Too soft springs are seldom found and the breakage in coiling is less than one-third of one per cent. The springs returned from the finishing department of the American factory for unsatisfactory performance in any direction amount to less than one-half of one per cent.

After the springs have been coiled, the tips riveted on, they are carefully gauged and then oiled to prevent rusting. They are then either

Dimensions of Mainsprings.

Millimeters and Fractions. *Compiled by L. A. Grosclaude, Geneva.*

No. of turns spring is capable of developing. Theoretical No. Reel No.	5	5½	6	6½	7	7½	8	9	10	
	4¼	5	5½	6	6½	7	7½	8½	9½	
No. of coils the Spring makes in the barrel when run down.	8.92	9.91	10.70	11.60	12.49	13.38	14.27	15.16	17.84	
Diameter of Barrel.	Length of Spring.		Length.		Length.		Length.		Length.	
	Thickness of Spring.		Thickness.		Thickness.		Thickness.		Thickness.	
Diameter of Arbor.	Length.		Length.		Length.		Length.		Length.	
	Thickness.		Thickness.		Thickness.		Thickness.		Thickness.	
Space occupied by Spring when run down.	Length.		Length.		Length.		Length.		Length.	
	Thickness.		Thickness.		Thickness.		Thickness.		Thickness.	
10	3.3	1.23	216	0.138	270	0.125	295	0.115	319	0.109
11	3.7	1.95	270	0.152	297	0.138	324	0.126	351	0.117
12	4.0	1.48	295	0.166	324	0.150	354	0.138	383	0.127
13	4.3	1.60	319	0.179	351	0.163	383	0.149	415	0.138
14	4.7	1.72	344	0.193	378	0.176	413	0.161	447	0.149
15	5.0	1.84	369	0.207	406	0.188	442	0.172	479	0.159
16	5.3	1.97	393	0.221	433	0.201	472	0.184	511	0.170
17	5.7	2.09	418	0.235	460	0.213	501	0.195	543	0.180
18	6.0	2.21	443	0.248	487	0.226	531	0.207	575	0.191
19	6.3	2.34	467	0.262	514	0.238	560	0.218	607	0.203
20	6.7	2.46	491	0.276	541	0.251	590	0.229	639	0.219
21	7.0	2.58	516	0.290	568	0.263	619	0.241	671	0.229
22	7.2	2.71	541	0.304	595	0.276	649	0.253	703	0.239
23	7.2	2.83	565	0.317	622	0.288	678	0.264	735	0.244
24	8.0	3.05	590	0.331	649	0.301	708	0.276	767	0.255
25	8.3	3.07	614	0.345	676	0.313	737	0.287	799	0.265
26	8.7	3.20	639	0.359	703	0.326	767	0.299	831	0.276
27	9.0	3.32	663	0.373	730	0.339	796	0.310	863	0.286
28	9.3	3.44	688	0.386	757	0.351	826	0.322	895	0.297
29	9.7	3.57	713	0.400	784	0.364	855	0.333	927	0.308
30	10.0	3.69	737	0.414	811	0.376	885	0.345	958	0.318
31	10.3	3.81	762	0.428	838	0.389	914	0.356	990	0.329
32	10.7	3.94	786	0.442	865	0.401	944	0.368	1022	0.339
33	11.0	4.06	811	0.455	892	0.414	973	0.379	1054	0.350
34	11.3	4.18	835	0.469	919	0.426	1003	0.391	1086	0.361
35	11.7	4.30	860	0.483	946	0.439	1032	0.402	1118	0.371
36	12.0	4.43	885	0.497	973	0.451	1062	0.414	1150	0.383
37	12.3	4.55	909	0.511	1000	0.464	1091	0.425	1182	0.393
38	12.7	4.67	934	0.524	1027	0.476	1121	0.437	1214	0.403
39	13.0	4.80	958	0.538	1054	0.489	1150	0.448	1246	0.414
40	13.3	4.92	983	0.552	1081	0.502	1180	0.460	1278	0.424
41	13.7	5.04	1007	0.566	1108	0.514	1209	0.471	1310	0.435
42	14.0	5.17	1032	0.580	1135	0.527	1239	0.483	1342	0.446
43	14.3	5.29	1057	0.593	1162	0.539	1268	0.494	1374	0.456
44	14.7	5.41	1081	0.607	1189	0.552	1298	0.506	1406	0.467
45	15.0	5.53	1106	0.621	1217	0.574	1327	0.517	1438	0.477
46	15.3	5.66	1130	0.635	1244	0.577	1357	0.529	1470	0.488
47	15.7	5.78	1155	0.649	1271	0.589	1386	0.540	1502	0.499
48	16.0	5.90	1179	0.662	1298	0.602	1416	0.552	1534	0.509
49	16.3	6.03	1204	0.676	1325	0.614	1445	0.563	1566	0.520
50	16.7	6.15	1228	0.690	1352	0.627	1474	0.575	1597	0.530
51	17.0	6.27	1253	0.704	1379	0.639	1504	0.586	1629	0.541
52	17.3	6.40	1278	0.718	1406	0.652	1533	0.598	1661	0.552
53	17.7	6.52	1302	0.731	1433	0.665	1563	0.609	1693	0.562
54	18.0	6.64	1327	0.745	1460	0.677	1592	0.621	1725	0.573
55	18.3	6.76	1351	0.759	1487	0.690	1622	0.633	1757	0.583
56	18.7	6.89	1376	0.773	1514	0.702	1651	0.644	1789	0.594
57	19.0	7.01	1400	0.787	1541	0.715	1681	0.655	1821	0.605
58	19.3	7.13	1425	0.800	1568	0.727	1710	0.667	1853	0.615
59	19.7	7.26	1450	0.814	1595	0.740	1740	0.678	1885	0.626
60	20.0	7.38	1474	0.828	1622	0.752	1769	0.690	1917	0.637

0.414

wound into capsules (from which they can be transferred directly into a watch barrel) or enclosed in packages containing one dozen each.

The product has been increased from sixty-five gross per month in 1886, to two thousand gross per month in 1892. Of this large amount about two thousand springs are required daily for the product of watches at the factory and the remainder are sold to the trade to supply the watch repairers throughout the country.

Cleaning Mainsprings. Workmen have often been seen cleaning a mainspring by seizing it with a rag and then drawing it out pitilessly and unmercifully. No other consequences can follow such treatment than the breakage of the spring on the earliest possible occasion. Cleaning is best done in the following manner: Lay the spring in benzine. As soon as the adhering oil is dissolved, take it out and seize it with a soft linen rag which imbibes the greater part of the adhering benzine. Cover the palm of the left hand with a corner of the rag; put the spring flat upon it and with the index finger of the right hand, around which another part of the rag is wound, press gently upon it, and let it assume a conical shape; by suitable motions of the finger while wiping, the spring will turn, and every part of its blade may easily and thoroughly be cleansed of all impurities. A spring treated in this manner will be freed of all matter, while at the same time its molecular arrangement is not violently interfered with, in a way calculated to injure its elasticity.

MAINSRING PUNCH. A punch used by watchmakers for perforating mainsprings. It is inserted in a vise when used. These punches are also made in the form of tongs or pliers.

MAINSRING WINDER. A good mainspring winder is a necessary adjunct to every watchmaker's bench. The Stark patent winder, shown in Fig. 231, is a very superior tool, is simple and durable,

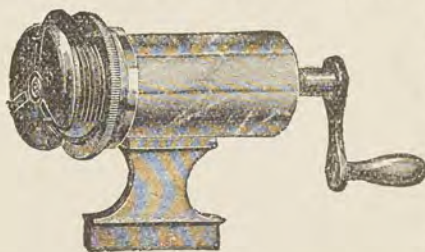

Fig. 231.

and should last for a life time. The winder is fastened in a vise: the adjustable nut is then turned until the barrel will fit loosely over the jaws; the barrel is then removed and the spring wound on the arbor inside the jaws. Now let the handle turn backward until the arbor is free from the center; pull

the arbor back and turn it half round; place the barrel back again over the jaws and spring, and hold it up tightly against the winder with the left hand; at the same time push the arbor forward with the right hand

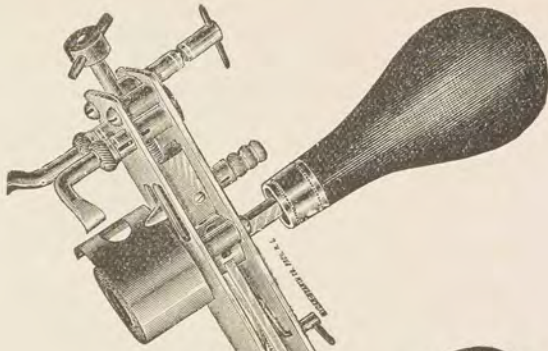

Fig. 234

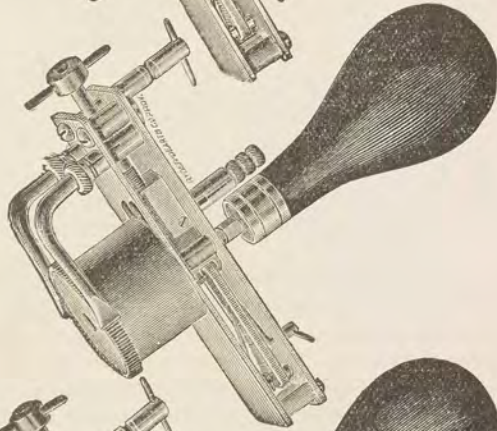

Fig. 233.

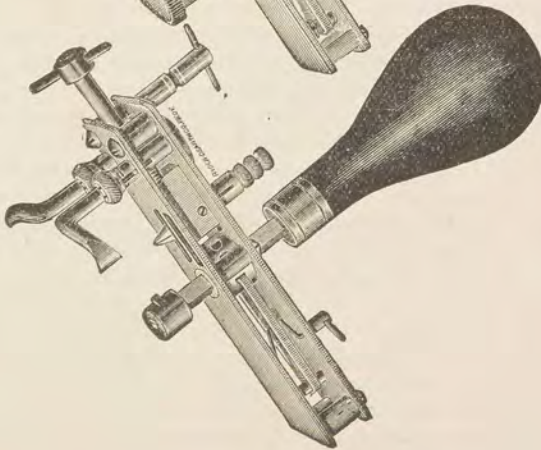

Fig. 232.

until the barrel and spring are free from the jaws, and the spring will be found to be in its proper place without further operation. There are two sizes of winding arbors, one for small and the other for large barrels. The arbors are easily changed by turning the thumb screw up until it is free, then changing the arbors and screwing the thumb screw down again.

The Vaughan patent mainspring winder, shown in the illustration, is intended for removing and replacing springs in clock barrels. Fig. 232 shows the machine ready for use; Fig. 233 shows the arms adjusted to the teeth of barrel, for holding barrel while spring is being wound. Fig. 234 shows the winder holding the spring after the barrel has been removed, and also as wound, ready to place in the barrel.

The claims made for this device are: It winds either way, as the case may require. Every part is adjustable, so that it will handle any spring, and hold any size barrel. Through the whole operation of removing the spring from the barrel and replacing it, the spring is kept in its natural position. After spring and barrel have been cleaned and barrel polished, they need not be touched with the hands, if the operator chooses to handle them with paper. The spring can be oiled when wound, as in Fig. 234, which carries the oil to bottom of the barrel, and prevents any excess of oil getting on the outside. It does not require a vise, but can be used in one place as well as another. There is no strain on the hands, more than winding the spring after it is in the clock. The plates and all the working parts are made of steel, and though light and neat in appearance, it is strong and durable.

To take the spring out of the barrel, adjust the arms used to hold the barrel, to the right height to meet the teeth of the barrel and swing them wide open, securing them by the thumb screw on the back of the winder. Place the barrel containing the spring over the winding arbor of the machine and catch the hook on the arbor to the spring. Swing the pawl lever to allow you to wind the way you desire, and turn the handle, allowing the barrel to turn with it, until the hook in the barrel, to which the outer end of the spring fastens, comes to within about one-half inch of the jaws which hold the outer edge of the spring on the machine. Free the arms and swing them into the teeth of the barrel, and with the barrel in the center of the machine, again secure them firmly by the thumb screw. Take the machine in the left hand, which will enable you to hold the arms tightly to the barrel, and the barrel down to the winder, without any danger of their springing away. Wind the spring nearly up, which will free the outer coil from the barrel, and allow you to adjust the jaws to the spring. Crowd the jaws onto the spring as far as possible and fasten them firmly to the spring by means of the thumb screw at the upper end of the winder. The spring is now transferred from the barrel to the winder, and the arms can be released and the barrel removed. Reverse the pawl lever and turn the handle up a trifle, when the pawl will change sides, allowing the spring to let down.

To replace the spring in the barrel, wind the spring on the machine, as shown in Fig. 234. Place the barrel over it, with the hook opposite the hole in the spring. Reverse the pawl lever and let the spring down. Release the jaws from the spring, and the work is done. The arms for holding the barrel are only used in taking the spring out.

MAINTAINING POWER. A mechanism for driving a watch or clock while being wound.

MALTESE CROSS. A wheel in the shape of a maltese cross, used in stop works.

MANDREL. A cheap form of lathe, but little used in this country, being superseded by the American lathe. It is known also as the Swiss Universal Lathe. The mandrel is worked by means of a handle, and is

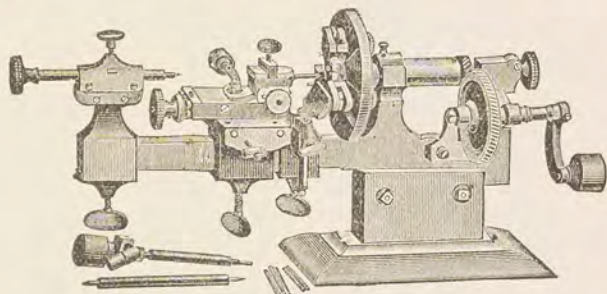

Fig. 235.

usually made with wheel and pinion, although a round belt or gut is sometimes used. It has a face plate, pump center, tail stock and slide rest. This tool is superfluous where the workman has an American lathe with slide rest and universal head; for on a lathe with these attachments, a greater variety of work can be performed in less time and in a better manner.

MASS. The amount of matter a body contains. It must not be confounded with weight, for the mass of a body remains the same, no matter in what part of the world it may be, but its weight would vary in different latitudes.

MATERIAL CUP. This cup will be found very useful to those who keep small material in bottles. The material, being placed in the cup, spreads out over the bottom, and the piece wanted is easily selected. The remainder can then be returned to the bottle through the spout with no danger of losing a piece.

MATTING. The grained or frosted surface given to work before gilding or silvering. See *Electro-Plating*.

MERIDIAN DIAL. An instrument for determining when the sun is on the meridian

MICROMETER. An instrument used for measuring very minute distances with extreme exactness. See *Gauge*.

MILLIMETER. A lineal measure based on the thousandth part of a meter, or about one-twenty-fifth of an inch. It is used principally by French watchmakers.

MILLING CUTTERS. It has been a difficult matter for mechanics

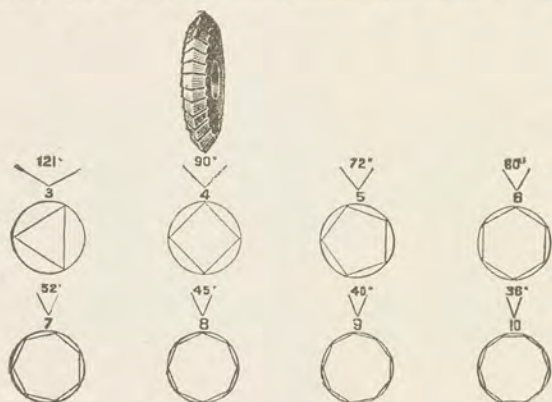

Fig. 236.

to understand the proper angle for a cutter to mill, or burr the stock, so that it will bend into the proper angle and make it a right joint. Fig. 236 will convey a very good idea of the proper shapes or angles for such cutters.

The angle of the cutter depends entirely on the number of sides the article is to have, and can always be determined by rule. The rule is a simple one, which is to divide 360° by the number of sides to the angle, i. e., $360 \div 4 = 90$.

MILLING FIXTURE. This attachment is fitted to the slide rest and holds the wire chuck vertically under the center of the lathe, so that articles held in the chucks can be fed under mills or saws held in the saw arbor.



Fig. 237.

MINUTE. The one-sixtieth part of an hour. Sixty seconds equal one minute.

MINUTE HAND. The hand of a time-piece which indicates the minutes and which traverses the circle of the dial once each hour.

MINUTE WHEEL. The wheel of the motion work into which the cannon pinion depths.

MINUTE WHEEL PINION. The pinion upon which the minute wheel is mounted and which depths with the hour wheel.

MINUTE WHEEL STUD. The pin or stud upon which minute wheel pinion revolves.

MITER GEARS. Gears whose shafts are at right angles to each other and whose diameters are equal. All miter gears are bevel gears, but all bevel gears are not miter gears.

MOINET, LOUIS. A clever watchmaker and writer of France. He was born at Bourges in 1768 and died in 1853.

MODULUS OF ELASTICITY. The measure of the elastic force of any substance, expressed by the ratio of a pressure on a given unit of the substance to the accompanying compression.
Webster.

MOMENT OF ELASTICITY. Is the tendency of an elastic body to produce motion.

MOMENT OF INERTIA. The resistance opposed by a body in motion to a change of velocity.

MOMENTUM. The amount of motion in a body, which is obtained by multiplying its mass by its velocity.

MOSELEY, CHARLES S. Mr. Moseley has been intimately connected with nearly every watch company in the United States, and as a mechanical engineer and designer of watch machinery, of the automatic type, he has had no superiors and but few equals. Among those that have acquired a world-wide reputation may be mentioned the interchangeable stem-wind mechanism of the Elgin National Watch Company; the dust-band used by the same company, the best and cheapest

ever made; the triangular hairspring stud; a patent regulator and the split chuck, an accessory now become universal and indispensable to every watchmaker in the land. He was born at Westfield, Mass., Feb.



Charles S. Moseley.

28, 1838. His first connection with watchmaking was in 1852, when he entered the employ of Dennison, Howard & Davis, at Roxbury, Mass. He followed the factory to Waltham and was employed in the capacity of foreman of the machine shop and later as master mechanic. In 1859 he became master mechanic of the Nashua Watch factory, and designed and built the machinery with which that watch was manufactured. In 1864 he joined the Elgin National Watch Company, then just starting, and was made general superintendent, in which capacity he remained with the company until 1877.

MOTEL, H. A French chronometer maker, pupil and successor of Louis Berthoud. His chronometers were remarkable for their close rates and for their beautiful construction. He died in 1859.

MOTION WORK. The wheels of a watch or clock which cause the hour hand to travel one-twelfth as fast as the minute hand.

MOVEMENT. A term usually applied to the mechanism of a watch or clock, independent of a case.

MOVEMENT BOX. A metal box with glass sides, for holding watch movements while timing, etc., before casing. In the Rockford box, shown in Fig. 239, stem wind movements can be wound without fingering or exposure to dust.



Fig. 239.



Fig. 240.

MOVEMENT COVER. A glass shade to protect a movement, or portions of a movement from dust and from being lost while undergoing repairs. Fig. 240 illustrates an improved cover, with wooden base

divided into compartments for the reception of the various parts, so they may be kept separate and readily picked out.

MOVEMENT HOLDER. A metal frame, as shown in Fig. 241, having three adjustable arms for holding the movement by clamping on to the plate. It is useful in putting a watch together, as it rests upon the bench and leaves both hands free to work with and the plates are kept free from finger marks.

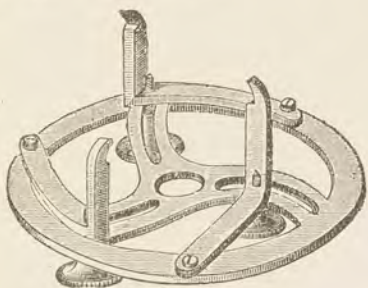

Fig. 241.



Fig. 242.

MOVEMENT REST. A wooden, bone or rubber shell, Fig. 242, similar to eye-glass frames, for holding movements while undergoing repairs, oiling, etc.

MUDGE THOMAS. The inventor of the lever escapement and a maker of marine chronometers. He was born at Exeter, England, in 1715. He was apprenticed to the celebrated George Graham in 1729.



Thomas Mudge.

From 1750 to 1771 he was engaged in business in Fleet street, London. In 1765 he invented the lever escapement. In 1771 he removed to Plymouth. In 1777 he was made clockmaker to the king. In 1793 Parliament voted him the sum of £2,500, he having previously received £500, as a reward for his marine time keepers. He devoted the greater part of his life to the improvement of the marine chronometer, and his work in this

line was celebrated for finish and correct proportion of details. He died Nov. 24, 1794.

NON-MAGNETIC WATCH. A watch whose parts cannot be polarized in a magnetic field; a watch whose quick moving parts are made of some other metal than steel or iron. Paillard, who has studied non-magnetic metals with great care, makes his balance springs of palladium, and his balances of palladium alloyed with copper, silver and other metals. In some instances he appears to have used a palladium

alloy for the inner part, and brass for the outer part of the rim, and in others to have formed both laminæ of different alloys of palladium. Aluminium bronze, which combines strength with lightness, is particularly suited for the lever and pallets. The American Waltham Watch Company have obtained remarkable results in non-magnetic watches, with an alloy of platinum. Steel in its hardened and tempered form, has long been used for the balance springs of watches, but from the fact that it owed its elasticity to the process of fire hardening, it has always been uncertain in its action, and often two springs from the same piece of steel would give very different results when put to the same tests. This, it is claimed, is not true of the alloy used by the Waltham Company. The non-magnetic spring, they claim, is a natural spring; it requires no rolling or hammering to harden or make it elastic. Its elasticity is a property of the alloy, and from nothing mechanical done to it, and that it cannot be annealed, or robbed of its elasticity, can be shown by heating it to a red heat of nearly 1,100 degrees Fahr., with no change of elasticity. At this degree of heat, steel is annealed, or becomes soft, and of no use as a spring.

In the expansion balance of ordinary construction, intended to compensate for temperature, steel is used as the metal of lowest expansion ratio, but in this case never in its hardened and tempered form. Such a balance would be too irregular in its action. No two balances would work alike, and anyone manufacturing such would find a difference of temper or degree of elasticity in each arm of the inside steel laminæ. The greatest controlling factor in the expansion balance, is the brass outside laminæ, and unless it is hammered or rolled it is of no practical use. A good expansion balance of the usual make depends more on the brass than the steel for its action, and it is a well known fact that brass is one of the most uncertain alloys known, and will often, when not in use, deteriorate to such an extent as to have no value for its original purpose. The Waltham non-magnetic balance is said to stand a change of temperature of 400 degrees Fahr., and return to its original form, as shown by gauges. The non-magnetic balance metals, while having the expansion ratio required, also have a greater natural degree of elasticity than the brass and steel construction, thus making a balance that, when in use in the watch, retains its shape, and will not get out of poise.

OIL. One of the most essential things to the good performance and durability of a watch or clock is good oil. A little thought given to the subject of oil will show how very essential it is that only the very best attainable be used. The mechanism of a fine watch, and particularly one of a complicated nature, is expected to perform regularly and with little or no variation, although after a thorough cleaning and oiling that mechanism may not fall into the hands of the repairer oftener than once a year and in the majority of cases it is a longer interval of time. There

are few mechanical contrivances from which so much is expected as a fine watch or chronometer, and yet there are none that receive, in proportion to their mechanism, so little care and attention. The engineer carefully wipes and oils his engine at least once a day: the machinist does the same with the lathes and machines under his care, but the watch, a mechanism far more complicated and from which much more is expected in regard to correct performance, does not receive this care oftener, on an average, than once a year. How essential it is then that the lubricant be of the finest possible quality.

The essential requisites of an oil that will insure correct performance of a watch during this time are:

1. It must remain liquid when exposed to severe cold.
2. It must evaporate slowly under intense heat.
3. It must not corrode on metal.
4. It must not become gummy.

What oils best withstand this test? For many years European watch-makers gave the preference to pure olive oil, but experiment has proven that this oil is wholly unfit for watches and the same may be said of all vegetable oils, for they invariably become gummy and turn green when placed in contact with brass. Neat's foot oils were found to possess similar unfitting qualities, and mineral oils are found to evaporate too quickly.

Nothing then remains but fish oils and those made from a species of porpoise known as the black fish, are considered the very best. Fine watch and chronometer oils of this class are prepared from the head and jaw only, which parts yield a limited quantity of very pure oil, known as "jaw and melon oil." This oil is carefully extracted without allowing any flesh or blood to come in contact with it, and after trying is filtered and retained in its native purity as nearly as possible, no bleaching, either by sun, acids or alkalies being employed. There is a popular fallacy existing in the trade that oils should be used when fresh, and even the acknowledged authority, Saunier, says, "do not buy, from motives of economy, bottles that have laid for years in the shop." This may be true and probably is, in regard to vegetable and animal oils, which are likely to become rancid if kept for a long time, but Wm. F. Nye, one of the largest and most celebrated manufacturers of fine watch and chronometer oils in the world, declares that black fish oils are improved by age, and his oils are seldom placed upon the market in the same year as obtained. We are indebted to the same authority for the statement that oils of this kind are clearer and more brilliant after some years than fresh oils. The Nye oils are tried at New Bedford, Mass., and in the following winter are sent to St. Albans, Vt., where it is chilled down and filtered at an average temperature of 25° below zero, and in some instances, even as low as 37° below zero. In this manner the specific gravity and density of the oil is increased, a finer grain and texture are

secured, giving increased resistance to the effects of both heat and cold. The two prominent manufacturers of black fish oils in this country, and we might say in the world, are Wm. F. Nye and Ezra Kelley, both of New Bedford, Mass. The watchmaker should be very careful what oils he uses, as many on the market are acid in tendency and are made from the olive, or are combinations of animal and vegetable oils.

OILER. A fine steel wire, mounted in a wooden or bone handle and used for applying oil to the mechanism of a watch or clock. Fig. 244

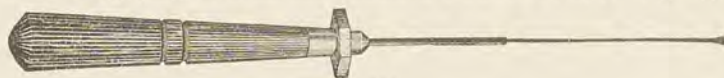

Fig. 244.

is an oiler, made with 14k. gold tip, and has a collet which keeps the point from touching the bench and also prevents oiler from rolling.

OIL SINK. The depression around the pivot holes for the purpose of furnishing a supply of oil and also retaining it at the pivots. When the oil sink is in metal which is not gilt and is blackened, if they should be polished out at the time of cleaning it will probably be at the expense of the fresh oil. Pivots should come well through the plate into the sink; if they do not the sink should be deepened. Oil sinks should be deep rather than wide, and well polished. Saunier says that care should be taken that the internal faces of the holes in which the shoulders of the axis rest, as well as the external faces, when these holes are provided with end-stones, are hollowed in *tallow drop* form, with a very slight interval between the bottom of the hole and the end-stone. When these precautions are taken, the oil, if not present in too great a quantity, will neither spread nor run down the axis, but will remain partly in the oil sink and partly attached to the shoulders of the axis, and in the case of pivot holes with end-stones, as the oil is exhausted, that spread over the end-stone will be drawn into the pivot hole through capillarity.

OILSTONE. A hard, gritty stone upon which oil is used for sharpening tools. The Arkansas and Washita stones are the two principal American grades, the former being the harder and finer. A mixture of one part alcohol and two parts glycerine will be found a much better lubricant for the oilstone where small tools, such as watchmakers use, are sharpened, than will the ordinary oils used. Oilstones often become so saturated with oil as to be almost useless and are often abandoned on this account. Such a stone, if soaked in benzine for a few days, will come out as good as new.

OILSTONE DUST. A preparation of powdered oilstone, used for smoothing pivots and other steel parts.

OVERBANKING. When the balance vibrates excessively and causes the ruby pin to push past the lever, it is known as overbanking.

OVERCOIL. The last coil of a Breguet hairspring, where it is bent over the body of the spring towards the center, is called the overcoil.

PALLET. That portion of an escapement by means of which the escape wheel gives impulse to the balance.

PALLET STAFF. The arbor on which the pallet is mounted.

PALLET STONES. The stones mounted in the pallet and on which the escape wheel strike and through which the impulse is transmitted.

PANTOGRAPH ENGINE. A machine or instrument for copying on the same, an enlarged or a reduced scale.

Making a Pantograph. In beginning a pantograph attachment we must have an arbor chuck to make our cutter on and to use it on after it is made. It would also be advisable to get a micrometer reading in thousandths of an inch. For the material for the machine we will first get a piece of soft steel $\frac{1}{8}$ inch by $\frac{3}{4}$ inch wide and 3 inches long. At $\frac{1}{4}$ inch from one end we will bend it at right angles, then find the center of its length from the inside of the bend to the other end. Then drill an $\frac{1}{8}$ inch hole with its center about $\frac{1}{8}$ inch from the upper edge as shown at A, Fig. 245. Next make the two oblong holes B C. A line drawn through their center should come $\frac{1}{8}$ inch from a line drawn through the center of A.

Then drill and tap the hole E for the screw that is to hold the index arm. At 2 is shown a plan view of the piece shown in elevation at 1. The blocks shown at F and G are held to the plate, 1, by the knurled screws and steady pin made solid with the block. Now it will be seen that for the different thicknesses of cutters which we wish to make, it will be necessary to move the blocks in order to have the center of our cutter blank come in line with the forming bar shown at H, 2. The hole to take the arbor chuck in block G should be bored out at 20° angle; that is what most first-class lathes are in the front end of spindle; with its center on a horizontal line with the center of the hole for the knurled screw.

The block F is drilled on the same line to take the steel center, I. The blocks F and G can be made of hard brass. The block G should not fit the arbor chuck back of the 20° angle but should be loose, so as to depend wholly on the angle and the steel center at the end of the chuck. Have the arbor chuck accurately centered before taking it out of the lathe.

The index at J, 2, can be obtained from any material house or

lathe manufacturer. We can mount the index plate in our Universal head and bore it out to take the collar, about $\frac{3}{8}$ inch outside diameter. Then bore out the collar to fit the arbor chuck. The index is fastened on to the chuck by a set screw the end of which fits the chuck spline. About sixty (60) divisions is what we need for making cutters from $\frac{1}{2}$ inch to $\frac{3}{8}$ inch diameter.

The knurled screws (2) can be purchased from any large hardware house. The index arm K, 2, should be of steel with a spring to keep it on the index.

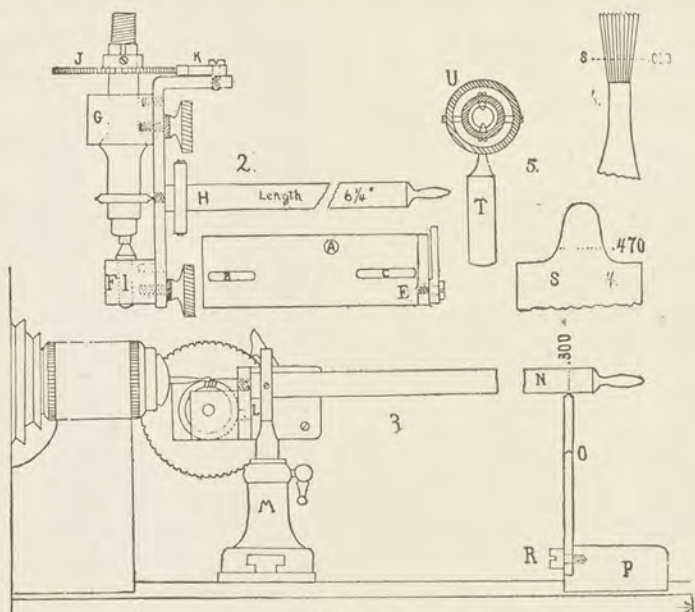

Fig. 245.

It will be seen from the drawings, that we are preparing to make a pinion cutter of 40 diametrical pitch.

We will now refer to 5. We have a universal joint which gives the free movement of our forming bar, H, 2. The joint is made of two steel rings $\frac{1}{8}$ inch wide and $\frac{1}{16}$ inch thick; the larger one being $\frac{3}{4}$ inch in diameter outside, and the smaller one $\frac{1}{2}$ inch in diameter outside. The piece T, 5, is turned to fit the T rest post; see M, 3.

Now drill and tap the larger ring U, 5, and screw in the piece T, having a very tight fit. Next drill and tap the ring U at 90° each side of the piece T. The smaller ring has four holes drilled 90° apart; two of them being smaller and reamed at a 60° taper to take the screws that are screwed through the outer ring and turned at

60° taper. The other two holes are tapped to take screws same as in the outer ring; these two screws fit into 60° taper holes drilled opposite each other in the forming-bar at $\frac{1}{8}$ inch from the shoulder where it is screwed into the plate. (2.)

The small forming cutter shown five times enlarged at 6 can be made of a piece of Stubb's wire .05 in. diameter and $\frac{3}{4}$ inch long. To turn the taper, set the slide-rest at 6° and turn it down till it measures .03 inch at .03 inch from the end which is made slightly

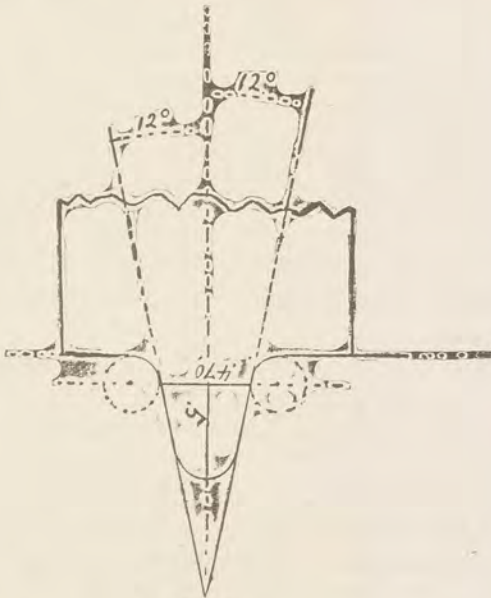

Fig. 246.

concave. Then cut ten teeth on it and harden and temper, after which it is ready to be used in a wire chuck in the head stock of the lathe.

The piece P that is fastened to the bed of the lathe to hold the form can be made of cast brass planed to fit the lathe-bed and held in position by a cam lever, as the head stock is. It is made with a step on the end to fit the lower end of the form O; this form is held in place by the screw R. Another view of the form, which is for a pinion cutter of forty pitch, is shown at S, 4; for convenience this is made of hard brass $1\frac{1}{2}$ inch wide and $\frac{1}{16}$ inch thick. First draw a vertical line through the center; then make the sides of the form 12° from the center line as in Fig. 246. The lines are connected

by a semi-circle and the curves below the pitch line are arcs of 0.3 inch circles; the width of the form at the pitch line is .47 inch, and the length from pitch line to the end is 0.5 inch.

Now it will be seen that the form is ten times larger than the cutter we wish to make and the part of our forming-bar that we move over the form is ten times longer from the universal joint than the distance from the universal joint to the center of our cutter blank, so that everything is ten to one. If we wish to make a cutter of different form it will only be necessary to make an exact form ten times larger than the cutter we wish to produce. If we wish to use a smaller forming cutter than .03 it will be necessary to reduce the end of the forming-bar accordingly, or if we wish to use a forming cutter of .05 diameter it will be necessary to use a collet on the forming bar .5 inch diameter to be moved over the form.

PARACHUTE. A mechanical contrivance used in some of the older watches, by which the endstone was held against the hole jewel by a spring sufficiently weak that if the watch received an extraordinary shock the endstones would yield and thus save the pivot from harm. Said to be the invention of Breguet.

PEG WOOD. Small round sticks of wood used for cleaning out pivot holes, etc.

PENDANT. The portion of a watch case to which the bow is attached, and the portion connecting it with the case.

Pendant Bow. The ring of metal by which the chain is attached to the case.

Pendant Bow Tightener. A form of pliers used for tightening and bending into form a loose or distorted pendant bow.

Pendant Bow Drill. A tool consisting of a loose spindle with a crank and drill rest, adapted to be used in the vise on the bench.

PENDULE WATCHES. A name given to watches of early construction having on one arm, or cross-piece of the balance, a representation of the bob of a pendulum and visible to the eye by a portion of the cock being cut away; thus this arm of the balance, at every vibration, would have the appearance as well as regularity of a pendulum.

PENDULUM. A body suspended from a fixed point in such a manner as to swing freely to and fro by the alternate action of gravity and momentum. The theoretical length of a pendulum, to beat seconds, or other time, depends upon its location, for the force that gravity exerts upon a body depends on the distance of the body from the center of the earth. The length of a seconds' pendulum at

The Equator is.....	39	inches
Rio de Janeiro.....	39.01	"
Madras.....	39.02	"
New York.....	39.1012	"
Paris.....	39.13	"
London.....	39.14	"
Edinburgh.....	39.15	"
Greenland.....	39.20	"
North and South Pole.....	39.206	"

Galileo's discovery of the law of pendulums was made in 1582 (See *Galileo*). Observing the regularity of the swinging of a lamp, suspended from the roof of the cathedral of Pisa, he noticed that, whatever the arc of vibration, the time of vibration remained nearly the same. If a slight angular movement be given to a freely suspended pendulum, its oscillations, while gradually diminishing in extent, will occupy periods, which at first sight, Galileo affirmed to be equal. He was mistaken, however, as the difference, although very slight with short arcs, is none the less real, and Huyghens discovered and proved that the oscillations of a pendulum are only isochronal when its center of oscillation describes a cycloidal path. By experiment, Galileo also determined the law of the length of pendulums. He found that by increasing the length of the pendulum the time of vibration increased.

The first application of the pendulum to clocks was made by Huyghens in 1657, although Galileo had some idea of this adaptation, and he even invented an escapement with a view to carrying it out.

Simple Pendulum. A purely theoretical pendulum, having no dimensions except length and no weight except at the center of oscillation. A material point suspended by an ideal line. The nearest approach to a simple pendulum is a heavy weight suspended by a fine silk thread, although this is known as a compound or physical pendulum.

Compound or Physical Pendulum. A heavy weight suspended from a fixed point by means of a slender thread or wire as shown in Fig. 247.

Oscillating Pendulum. A pendulum that moves backward and forward and whose lower extremity traces an arc. This term is used to distinguish an ordinary pendulum (which is an oscillating pendulum), from a conical or torsion pendulum. Fig. 247 is an oscillating pendulum and its path is denoted by the dotted lines.

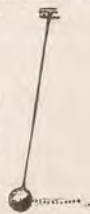

Fig. 247.

Conical Pendulum. A pendulum which in its swing describes the figure of a cone in the air. A pendulum whose lower extremity

describes a circle as shown by the dotted lines in Fig. 248. By comparison it will be found that a conical pendulum completes its circular travel in the same time that an oscillating pendulum requires to make a complete swing, back and forth.



Fig. 248.

Torsion Pendulum. A torsion pendulum is one that depends for its vibrations upon the twisting and untwisting of an elastic suspension. The path of a torsion pendulum is unlike that of other pendulums, as it does not swing from right to left, but simply revolves horizontally, the suspension acting as an axis. The action of a torsion pendulum is very simple; after turning the bob or weight and releasing it, the elasticity of the wire or other suspension returns it to the point of rest and the momentum of the weight carries it forward, twisting the suspension in the opposite direction, until the weight reaches a point where the momentum of the weight is overbalanced by the resistance of the suspension, when the suspension again untwists, turning the bob in the opposite direction. These oscillations, which, within certain limits are very nearly equal, continue until the force originally applied is exhausted in friction. The application of the torsion pendulum to clocks has been successfully accomplished. By its use either of two results may be secured; the time of running may be prolonged in proportion as the period of the torsion pendulum is longer than that of an oscillating one, or the number of gear wheels required in the clock may be greatly reduced. Ordinary clocks have been constructed on this principle that would run a year with a single winding, while others have been constructed that would run a much longer period. Fig. 249 illustrates a simple torsion pendulum that can easily be constructed for experimental purposes. It has parallel suspension wires $\frac{3}{8}$ inch apart and 5 feet long, made from No. 30 brass spring wire. The bob is formed of a disc of metal, with a series of split lead balls pinched down upon its edge. It has a double loop fixed at the center for fastening the suspension wires. The diameter of the disc is 4 inches and the total weight of bob $1\frac{1}{2}$ pounds.



Fig. 249.

Laws of Pendulums. There are three laws in regard to the movement of simple pendulums that are well to remember. 1. *The number of vibrations performed by pendulums in a given time are inversely as the square roots of the lengths.* If the bob is displaced from the vertical and released, it will return, and ascend to an equal distance on the other side in virtue of its weight. The velocity of movement of the pendulum is in accordance with the laws of falling bodies for the moving pendulum is no more than a falling body under certain restrictions. If we assume the pendulum to be displaced laterally until its rod is in a

horizontal position, it will be seen that the distance through which it descends is equal to the length of the pendulum. Hence it follows that the descent of a short pendulum will, in virtue of the laws above referred to, take place in much less time than that of a long one. Thus, consider the case of a short pendulum whose length is a quarter of that of the longer one; the shorter will travel twice as quickly as the longer, or, in other words, it will perform two oscillations while the longer performs one. The lengths are as 1:4 and the square roots of these numbers are 1 and 2; thus the number of oscillations are inversely as these square roots.

The times occupied in the descent, or the periods of the oscillations, are proportional to the square roots of the length. If the longer pendulum fall in 2 seconds, the shorter falls twice as quickly and will therefore reach the vertical in 1 second; and 2 and 1 are the square roots of the length 4 and 1.

3. *The lengths are inversely proportional to the squares of the number of oscillations in a given time.* If we observe that:

The lengths are.....1 and 4.

The corresponding number of oscillations.2 and 1.

The squares of these number.....4 and 1.

we have some evidence of the truth of this law. These several laws will enable us to determine the length of pendulum for any case that presents itself.

Saunier gives the following method for determining the length of a simple pendulum, the numbers of oscillations being given, or *vice versa*. Let the pendulum be required to perform 7,000 oscillations in an hour. The simple seconds pendulum (at Paris) measures 994 mm. (39.13 in.), and it makes 60 × 60 or 3,600 oscillations per hour; we thus, from the law 3 above given, have the proportion:

$$\begin{aligned} 7,000 \times 7,000 : 3,600 \times 3,600 & : : 994 : x \\ \text{or } 49,000,000 : 12,960,000 & : : 994 : x \end{aligned}$$

Dividing the product of the means by the known extreme we obtain:

$$x = \frac{12,960,000 \times 994}{49,000,000} = 262.9 \text{ mm. (10.35 ins.)}$$

If the length of a pendulum be given, say 121 mm. (4.764 ins.), the number of oscillations will be calculated in accordance with law 1:

$$\begin{aligned} \sqrt{121} : \sqrt{994} & : : 3,600 : x \dagger \\ \text{or } 11 : 31.525 & : : 3,600 : x \end{aligned}$$

† The radix sign $\sqrt{\quad}$ indicates that the root is to be extracted from the number placed under it.

whence we obtain

$$x = \frac{31.525 \times 3,600}{11} = 10,317, \text{ the required number of oscillations.}$$

From the above it will be seen that it was very easy to find the length of the pendulum for a given number of vibrations, or *vice versa*, although such calculations are quite useless while we have the accompanying table of lengths of pendulums for any number of oscillations. However, it may often be necessary to solve such problems where you do not have access to such tables, and it is therefore valuable to know just how to proceed.

M. Millet gives another method which is rather more simple. Take as a basis for calculation the pendulum that performs *one oscillation in an hour*, the length of which is 12,880,337.93 meters (507,109,080 inches) or in round numbers, 12,880,338 meters; by law 3 we obtain the following proportion:

$$12,880,338 : x \text{ (the length)} : : V^2 \text{ (the velocity)} : 1^2$$

Since the square of 1 is 1, it is only necessary to replace x by the length (if this is given), or V by the number of oscillations in an hour, (if they are pre-determined), and the value of the unknown quantity will be obtained.

Example: How many oscillations will be made by a pendulum measuring 305 mm. (12.008 inches)?

We have the proportion: 12,880,338 : 0.305 : : V^2 : 1.

Dividing the product of the extremes by the known mean, *

* To extract the square root of a whole number, place a point or dot over the units' place of the given number, and thence over every second figure to the left of that place, thus dividing the whole number into several periods. The number of points will show the number of figures in the required root. Find the greatest number whose square is contained in the first period at the left; this is the first figure in the root, and may be ascertained by the aid of the following table;

Number	1,	4,	9,	16,	25,	36,	49,	64,	81.
Square Root	1,	2,	3,	4,	5,	6,	7,	8,	9.

Subtract the square of the number so determined from the first period and to the remainder bring down the second period. Divide the number thus formed, omitting the last figure, by twice the part of the root already obtained, and annex the quotient to the root and also to the divisor. Then multiply the divisor, as it now stands, by the part of the root last obtained, and subtract the product from the number formed, as above mentioned, by the first remainder and the second period. If there be more periods to be brought down the operation must be repeated, and if, when all the periods have been so brought down, there is a remainder, the given number has no exact square root. If the number be a decimal fraction, or a whole number and a decimal combined, proceed in a similar manner, but observe that a point must always occur over the units' figure and on alternate figures from it on either side to the right and left. A decimal point will be placed in the square root immediately

$$V^2 = \frac{12,880,338}{0.305} = 42,230,616,$$

and V will be the square root of this number, or 6,498 oscillations per hour.

If the dimensions are given in English inches, the numbers 507,109,080 and 12.008 would be employed thus:

$$507,109,080 : 12.008 : V^2 : 1;$$

$$V^2 = \frac{507,109,080}{12.008} = 42,230,936.$$

The slight difference in the results is due to the non-equality of the two approximate figures given above. Another example is given in which it will suffice to indicate the several stages of the calculation.

Example: What should be the length of a pendulum to give 4,100 oscillations per hour?

$$12,880,338 : x : : 4,100^2 : 1;$$

$$12,880,338 : x : : 16,810,000 : 1;$$

$$x = \frac{12,880,338}{16,810,000} = 0.766 \text{ meters (30.158 inches).}$$

before bringing down the first decimal period, and in cases where the given number has no exact root, it may be approximated to by bringing down successive pairs of ciphers. *Example:* Extract the square root of 273,529.

$$\begin{array}{r} \overset{\cdot}{2} \overset{\cdot}{7} \overset{\cdot}{3} \overset{\cdot}{5} \overset{\cdot}{2} \overset{\cdot}{9} (523 \\ \underline{25} \\ 102 \quad \left| \begin{array}{l} 235 \\ 204 \\ \hline 3129 \\ 3129 \\ \hline \end{array} \right. \end{array}$$

Applying the above rule, the square of 5 or 25, the largest contained in 27, is subtracted from the first period, and to the remainder, the second period, 35, is attached. The divisor for the dividend so formed is obtained by doubling the portion of the root already determined (5), and annexing 2 to the 10, since 10 will divide twice into 23, the dividend with the last figure omitted. The 2 is also added to the quotient as forming a figure in the root, and 102 multiplied by it as in ordinary division. The next period, 29, having been brought down to the remainder thus obtained, a similar operation is again gone through, the entire quotient, so far as it has been determined, being each time doubled.

Table Showing the Length of a Simple Pendulum

That performs in one hour any given number of oscillations, from 1 to 20,000, and the variation in this length that will occasion a difference of 1 minute in 24 hours.

Calculated by E. Gourdin.

Number of Oscillations per Hour.	Length in Millimeters.	Variation in Length for One Minute in 24 Hours in Millimeters.	Number of Oscillations per Hour.	Length in Millimeters.	Variation in Length for One Minute in 24 Hours in Millimeters.	Number of Oscillations per Hour.	Length in Millimeters.	Variation in Length for One Minute in 24 Hours in Millimeters.
20,000	32.2	0.04	13,200	73.9	0.10	8,200	191.5	0.26
19,000	35.7	0.05	13,100	75.1	0.10	8,100	196.3	0.27
18,000	39.9	0.05	13,000	76.2	0.10	8,000	201.3	0.27
17,900	40.2	0.06	12,900	77.4	0.11	7,900	206.4	0.28
17,800	40.7	0.06	12,800	78.6	0.11	7,800	211.7	0.29
17,700	41.1	0.06	12,700	79.9	0.11	7,700	217.2	0.30
17,600	41.6	0.06	12,600	81.1	0.11	7,600	223.0	0.30
17,500	42.1	0.06	12,500	82.4	0.11	7,500	229.0	0.31
17,400	42.4	0.06	12,400	83.8	0.11	7,400	235.2	0.32
17,300	43.0	0.06	12,300	85.1	0.12	7,300	241.7	0.33
17,200	43.5	0.06	12,200	86.5	0.12	7,200	248.5	0.34
17,100	44.0	0.06	12,100	88.0	0.12	7,100	255.7	0.35
17,000	44.6	0.06	12,000	89.5	0.12	7,000	263.2	0.36
16,900	45.1	0.06	11,900	91.0	0.12	6,900	270.5	0.37
16,800	45.7	0.06	11,800	92.5	0.13	6,800	278.6	0.38
16,700	46.3	0.06	11,700	94.1	0.13	6,700	286.9	0.39
16,600	46.7	0.07	11,600	95.7	0.13	6,600	295.7	0.40
16,500	47.3	0.07	11,500	97.4	0.13	6,500	304.9	0.41
16,400	47.9	0.07	11,400	99.1	0.13	6,400	314.5	0.43
16,300	48.5	0.07	11,300	100.9	0.14	6,300	324.5	0.44
16,200	49.1	0.07	11,200	102.7	0.14	6,200	335.1	0.46
16,100	49.7	0.07	11,100	104.5	0.14	6,100	346.2	0.47
16,000	50.0	0.07	11,000	106.5	0.14	6,000	357.8	0.48
15,900	51.0	0.07	10,900	108.4	0.15	5,900	370.0	0.50
15,800	51.6	0.07	10,800	110.5	0.15	5,800	382.9	0.52
15,700	52.3	0.07	10,700	112.5	0.15	5,700	396.4	0.54
15,600	52.9	0.07	10,600	114.6	0.16	5,600	410.7	0.55
15,500	53.6	0.07	10,500	116.8	0.16	5,500	425.8	0.58
15,400	54.3	0.08	10,400	119.1	0.16	5,400	441.0	0.60
15,300	55.0	0.08	11,300	111.4	0.17	5,300	458.5	0.62
15,200	55.7	0.08	10,200	123.8	0.17	5,200	476.3	0.65
15,100	56.5	0.08	10,100	126.3	0.17	5,100	495.2	0.67
15,000	57.3	0.08	10,000	128.8	0.18	5,000	515.2	0.70
14,900	58.0	0.08	9,900	131.4	0.18	4,900	536.5	0.73
14,800	58.8	0.08	9,800	134.1	0.18	4,800	559.1	0.76
14,700	59.6	0.08	9,700	136.9	0.19	4,700	583.1	0.79
14,600	60.4	0.08	9,600	139.8	0.19	4,600	608.7	0.83
14,500	61.3	0.08	9,500	142.7	0.19	4,500	636.1	0.86
14,400	62.1	0.09	9,400	145.8	0.20	4,400	665.3	0.90
14,300	63.0	0.09	9,300	148.9	0.20	4,300	696.7	0.95
14,200	63.9	0.09	9,200	152.2	0.21	4,200	730.2	0.99
14,100	64.8	0.09	9,100	155.5	0.21	4,100	766.2	1.04
14,000	65.7	0.09	9,000	159.0	0.22	4,000	805.0	1.09
13,900	66.7	0.09	8,900	162.6	0.22	3,900	825.5	1.12
13,800	67.6	0.09	8,800	166.3	0.23	3,800	846.8	1.15
13,700	68.6	0.09	8,700	170.2	0.23	3,700	869.0	1.18
13,600	69.6	0.09	8,600	173.7	0.24	3,600	892.0	1.21
13,500	70.7	0.09	8,500	178.3	0.24	3,500	915.9	1.25
13,400	71.7	0.10	8,400	182.5	0.25	3,400	940.1	1.28
13,300	72.8	0.10	8,300	187.0	0.25	3,300	966.8	1.31

Table of the Length of a Simple Pendulum,

(CONTINUED.)

Number of Oscillations per Hour.	Length in Meters.	To Produce in 24 Hours 1 Minute.		Number of Oscillations per Hour.	Length in Meters.	To Produce in 24 Hours 1 Minute.	
		Loss, Lengthen by Millimeters.	Gain, Shorten by Millimeters.			Loss, Lengthen by Meters.	Gain, Shorten by Meters.
3 600	0.9939	1.38	1.32	1,900	3.568	0.0050	0.0048
3,550	1.0221	1.42	1.36	1,800	3.975	0.0055	0.0053
3,500	1.0515	1.46	1.40	1,700	4.457	0.0062	0.0059
3,450	1.0822	1.50	1.44	1,600	5.031	0.0070	0.0067
3,400	1.1143	1.55	1.48	1,500	5.725	0.0080	0.0076
3,350	1.1477	1.60	1.53	1,400	6.572	0.0091	0.0087
3,300	1.1828	1.64	1.57	1,300	7.622	0.0106	0.0101
3,250	1.2194	1.69	1.62	1,200	8.945	0.0124	0.0119
3,200	1.2578	1.75	1.67	1,100	10.645	0.0148	0.0142
3,150	1.2981	1.80	1.73	1,000	12.880	0.0179	0.0171
3,100	1.3403	1.86	1.78	900	15.902	0.0221	0.0211
3,050	1.3846	1.93	1.84	800	20.126	0.0280	0.0268
3,000	1.4312	1.99	1.90	700	26.287	0.0365	0.0350
2,900	1.5316	2.13	2.04	600	35.779	0.0497	0.0476
2,800	1.6429	2.28	2.18	500	51.521	0.0716	0.0685
2,700	1.7669	2.46	2.35	400	80.502	0.1119	0.1071
2,600	1.9054	2.65	2.53	300	143.115	0.1989	0.1903
2,500	2.0609	2.87	2.74	200	322.008	0.4476	0.4282
2,400	2.2362	3.11	2.97	100	1,288.034	1.7904	1.7131
2,300	2.4349	3.38	3.24	60	3,577.871	4.9732	4.7586
2,200	2.6612	3.70	3.54	50	5,152.135	7.1613	6.8521
2,100	2.9207	4.06	3.88	1	12,880,337.930	17,903.6700	17,130.8500
2,000	3.2201	4.48	4.28				

The numbers given represent the oscillations in an hour of mean time of a *simple* pendulum, measuring from the point of suspension to the center of a heavy spherical bob attached to a fine thread, and oscillating through an exceedingly small arc in a vacuum.

The compound or material pendulum employed for regulating horological trains will give the number of oscillations indicated in the table when the length set opposite that number is equal to the distance between the centers of suspension and oscillation.

The assumption that the center of oscillation coincides approximately with the point at which the pendulum will rest horizontally on a knife-edge, is only legitimate when the rod is very light, and the weight of the pendulum acts nearly through the center of the bob.

The watchmaker will do well to employ a small platinum ball, suspended in front of a carefully graduated vertical rule, by a fine thread that can be lengthened or shortened at will. If the point of suspension is determined by a clamp that is opened or closed by a set screw, it will be easy to adjust this pendulum to the length indicated in the table, and, by making it oscillate side by side with the compound pendulum under consideration, to ascertain the approximate position of the center of suspension of this latter.

The length of the pendulum giving 1 oscillation in an hour (12,880,337.93 meters, or 507,109,080 inches), affords a useful datum for certain calculations with reference to the lengths of pendulums. For an oscillation of 2° the lower end will travel through a space of 280 miles.

In the above table all dimensions are given in meters and millimeters. If it is desirable to express them in feet and inches, the necessary conversion can be at once effected in any given case by employing the following conversion table, which will prove of considerable value to the watchmaker for various purposes.

Inches expressed in Millimeters and French Lines.		Millimeters expressed in Inches and French Lines.		French Lines expressed in Inches and Millimeters.				
Inches.	Equal to		Millimeters.	Equal to		French Lines.	Equal to	
	Millimeters	French Lines.		Inches.	French Lines.		Inches.	Millimeters
1	25.39954	11.25951	1	0.0393708	0.44329	1	0.089414	2.25583
2	50.79908	22.51903	2	0.0787416	0.88659	2	0.177628	4.51166
3	76.19862	33.77854	3	0.1181124	1.32989	3	0.266441	6.76749
4	101.59816	45.03806	4	0.1574832	1.77318	4	0.355255	9.02332
5	126.99771	56.29757	5	0.1968539	2.21648	5	0.444069	11.27915
6	152.39725	67.55709	6	0.2362247	2.65978	6	0.532883	13.53497
7	177.79679	78.81660	7	0.2755955	3.10307	7	0.621697	15.79080
8	203.19633	90.07612	8	0.3149664	3.54637	8	0.710510	18.04663
9	228.59587	101.33563	9	0.3543371	3.98966	9	0.799324	20.30246
10	253.99541	112.59515	10	0.3937079	4.43296	10	0.888138	22.55829
						11	0.976952	24.81412
						12	1.065766	27.06995

A meter is the forty-millionth part of a meridian of the earth. A decimeter is the tenth part of a meter. A centimeter is the hundredth part of a meter. A millimeter is the thousandth part of a meter.

$$\left. \begin{array}{l} 1 \text{ meter} \\ 10 \text{ decimeter} \\ 100 \text{ centimeters} \\ 1000 \text{ millimeters} \end{array} \right\} \begin{array}{l} \text{is} \\ \text{equivalent} \\ \text{to} \end{array} \left\{ \begin{array}{l} 39.37079 \text{ inches,} \\ 3.28095 \text{ feet,} \\ 1.09363 \text{ yards or} \\ 0.00035138 \text{ miles} \end{array} \right.$$

$$\begin{array}{l} 1 \text{ square centimeter} = 0.15501 \text{ square inch.} \\ 1 \text{ square inch} = 6.45127 \text{ square centimeter.} \\ 1 \text{ cubic centimeter} = 0.06103 \text{ cubic inches.} \\ 1 \text{ cubic inch} = 16.38618 \text{ cubic centimeters.} \end{array}$$

To Calculate the Vibrations of a Pendulum. Multiply together the number of teeth of the wheels, starting with the one that carries the minute hand (which makes one revolution per hour), but omit the escape wheel. Multiply together the numbers of leaves of the pinions, commencing with the one that engages with the center wheel. If the first product be divided by the second, the number obtained gives the *number of revolutions* of the escape wheel in an hour. Multiply this figure by *twice the number* of teeth of the escape wheel, and the product is the number of single vibrations performed by the pendulum in one hour. The vibrations of a balance may be calculated in precisely the same manner.

Mercurial Compensation. In the mercurial pendulum with a glass jar, the mercury does not answer so quickly to a change of temperature as the steel rod, and preference is therefore now generally given to thin metal jars; still the elegant appearance of the glass jar in a stirrup renders it suitable for show regulators, for which it is still retained. The following are the dimensions of a good seconds pendulum of this class: Steel rod, .3 inch in diameter, 43 inches long from top of free part of suspension spring to bottom of sole of stirrup; side rods of stirrup, .3 inch wide and .125 inch thick; height of stirrup inside, 8 inches, bottom of stirrup, .5 inch thick with a recess turned out to receive the jar; glass jar 7.6 inches deep and 2 inches in diameter inside, outside 2.25 in diameter, and 7.8 inches high; height of mercury in the jar about 7.4 inches; the weight of mercury 11 lbs. 12 oz. The steel parts may with advantage be annealed to guard against the possibility of magnetism.

The mercury divided between two jars answers quicker to changes of temperature.

Precision clocks with mercurial pendulums have jars larger in diameter than two inches, made of cast iron enameled on the inside, or of steel.

Great care should be taken, when filling the mercury jar, to avoid air bubbles. The best plan is, push the center of a good silk handkerchief

into the jar and pour in the mercury through a long boxwood or other funnel with but a mere pinhole for the outlet. When the whole of the mercury is poured in, carefully draw up the handkerchief by its four corners. The jar of mercury, with a piece of bladder tied over the top, may then be subjected to a temperature of about 120° for a week or two.

It is important to get the mercury as pure as possible for a pendulum. A good way of removing impurities is to add sulphuric acid to the mercury and shake the mixture well. The metal is then washed, and afterwards dried on blotting paper. Another method of purifying mercury is to put it in a bottle with a little finely-powdered loaf sugar. The bottle is stoppered and shaken for a few minutes, then opened and fresh air blown in with a pair of bellows. After this operation has been repeated three or four times, the mercury may be filtered by pouring it into a cone of smooth writing-paper, the apex of which has been pierced with a fine pin. The sugar and impurities will be retained by the cone. Some filter mercury by squeezing it through a piece of fine chamois leather. In dealing with mercury, care should be taken to avoid the injurious vapor which rises from it even at the ordinary temperature of the air, and of course more freely at higher temperatures.

Wood Rod and Lead Bob. A cheap and good compensating pendulum may be made with a wood rod and lead bob. For a seconds pendulum the rod should be .5 inch in diameter, of thoroughly well-seasoned straight-grained pine 45 inches long, measuring from the top of the free part of the suspension spring to the bottom of the bob. A slit for the suspension spring is cut in a brass cap fitting over the top of the rod, to which it is secured by two pins. A bit of thin brass tube is fitted to the rod where it is embraced by the crutch. The rating screw, .25 inch in diameter, is soldered to a piece of brass tubing fitting over the rod and secured by a couple of pins. Wooden rods require to be coated with something to render them impervious to the atmosphere. They are generally varnished or polished, but painting them answers the purpose well. Mr. Latimer Clark recommends saturating them with melted paraffin. The bob, 2.25 inches in diameter and 12 inches high, with a hole just large enough to go freely over the wood rod, rests on a washer above the rating nut. Shorter pendulums for chime and other clocks are made of cherry, mahogany, and ebony, simply because in such small sizes pine does not allow of sound attachment to the ends. These pendulums have generally lenticular-shaped bobs. Such rods cost scarcely any more than brass or iron, and are infinitely preferable.

It is essential that the grain of a wood pendulum rod should be perfectly straight, for if the grain is not straight, the rod is likely to bend, causing the clock to go very irregularly.

Importance of Fixing. Whatever kind of pendulum is used, it will not keep time unless it is rigidly fixed. Just as engineer clockmakers

invariably make their escape wheels and other moving parts too heavy, so clockmakers always seem afraid to put enough metal in their pendulum cocks and brackets, which have rarely enough base either. The beneficial effect of the heavy pendulum bobs, which it has been the custom recently to use for regulator and turret clocks, is often quite lost for want of sufficient fixing for the pendulum. For a regulator, the pendulum should be supported on a cast-iron bracket with a base at least 10 inches square, bolted right through the back of the case, which should be not less than an inch and a quarter thick. For a turret clock a bracket of a proportional size should be used, bolted to one of the main walls of the building, or, if attached to the clock frame, the rigid connection of the latter with the walls by means of girders or cantilevers should not be lost sight of. A timber frame fixing for a turret clock pendulum will never be satisfactory.

Length of Pendulums. One-second pendulums are long enough for all but turret clocks, and longer than two-second pendulums should not be used. The very long pendulums used by the old clockmakers for turret clocks in order to get, as they expressed it, "dominion over the clock," were unwieldy and unsteady from the action of the wind and other causes. The requisite "dominion" is now obtained by making the bob heavier.

Pendulum Error. The long and short vibrations of a free pendulum will only be isochronous if the path described is a cycloid, which is a curve described by rolling a circle along a straight line. If the generating circle, instead of being rolled on another circle, were rolled along a straight edge, it would describe a cycloid. But a pendulum swung freely from a point travels through a circular path, and the long arcs are performed slower than the short ones. This divergence from the theoretical cycloid was of great importance when the arc described was large, as it was of necessity with the verge escapement, and many devices were tried to lead the pendulum through a cycloid. With an arc of about 3° only, such as regulator pendulums describe now, the divergence is very small.

Escapement Error. The kind of escapement used also affects the time of vibration; for instance, it is found that, while with the recoil escapement increased motive power and greater arc causes the clock to gain, the contrary effect is produced with the dead-beat escapement. The pendulum error may, therefore, be aggravated or neutralized by the escapement error.

Temperature Error. With increase of temperature, the pendulum, in common with most other substances, lengthens, and the clock loses; with decrease of temperature the contrary effect is produced. The

object of the compensation pendulum is to meet the error arising from change of temperature by keeping the distance between the point of suspension and the center of oscillation constant.

Barometric Error. With a decrease in the pressure of the air, and consequent fall of the barometer, the pendulum increases its arc of vibration; with an increase in the pressure of the air, and consequent rise of the barometer, the pendulum diminishes its arc of vibration. In the Westminster clock the pendulum vibrates 2.75° on each side of zero, and Sir Edmund Beckett pointed out that with this large arc the circular error just compensates for the barometric error. Where the escapement is suitable, this is doubtless the best way of neutralizing the barometric error; but it is not applicable to the dead-beat, for extra run on the dead faces of the pallets or larger angle of impulse than usual is found to be detrimental, as the oil thickens.

Rolling or Wobbling. The path of a pendulum in plan should be a straight line. Any deviation from this will affect the regularity of its timekeeping. A want of squareness in the chops, or a twist in the suspension spring, will often cause rolling or wobbling. Many clockmakers fix the lower end of the spring with but one screw, so that the pendulum may hang plumb without danger of binding. If the pallet staff is not perfectly at right angles to the path of the pendulum, rolling may be caused by the oblique action of the crutch. This shows the necessity of care in adjusting the movement on the seat board in cased clocks, and is an argument in favor of attaching the pendulum of a turret clock to the frame of the movement, instead of to a separate wall bracket.

PENDULUM SPRING. The ribbon or ribbons of steel used in suspending the pendulum.

PERRON, M. A celebrated French watchmaker and author. Born at Besancon, in 1779.

PILLAR. Posts of brass used to keep the plates of a watch in position.

PILLAR PLATE. The plate of a watch to which the pillars are attached.

PINION. The smaller of two toothed wheels which are geared into one another. The tooth of a pinion is called a pinion leaf.

Pinion Grinder and Polisher. The ends of the leaves of pinions, when ground flat and polished, add very much to the beauty of a job when completed. Proceed to turn down your pinion in the lathe and fit

it in the usual manner, ready for finishing. Now select a suitable chuck to hold the pinion in the lathe, and take a few copper cartridge shells, used in 22 or 32 caliber revolvers, and drill four holes in the end to fit the staff of the pinion you wish to polish. Fit a piece of wood about three inches long in the open end of the cartridge shells to use as a handle; do not allow the handle to enter the shell over one-fourth of an inch, so that it will not strike against the pivot of the pinion while polishing. Now file flat the closed end of the cartridge, and your grinding and polishing tool is completed. Insert the pinion in one of the holes of the shell so that the flat surface of the shell will come up squarely against the face of the leaves of the pinion. Apply a paste made of emery flower and sweet oil, and run the lathe at a high speed, pressing slightly against the pinion leaves. Transfer from one hole to another, to insure flatness. Clean off the pinion with benzine and examine to see if the marks of the turning tool are all out. If not, proceed as before. Take another shell prepared in like manner, and use crocus and oil, instead of emery, and grind out the scratches of the emery. After removing these, wash thoroughly in benzine, and with another copper shell proceed to polish, using a paste of diamantine and oil or alcohol. A good polish will soon appear. Care must be exercised to see that the work is thoroughly cleaned after each process. The shells can then be laid away in separate boxes for future use. During leisure moments you can prepare a number of the shells to fit almost any job, and you will find them very handy for many purposes.

PIN PALLET ESCAPEMENT. This escapement is not often met with except in French clocks, and the escapement is generally exported. It is difficult to keep the oil on the pallets, and for other reasons it is not a favorite escapement either with English or American watchmakers.

PIN VISE. An improved form of pin vise is that shown in Fig. 250, manufactured by A. J. Logan. It is hollow throughout its entire



Fig. 250.

length and closes together, the same as a chuck on the American lathe. It will hold a small drill or wire perfectly true and will be found very useful for many purposes.

PIN WHEEL ESCAPEMENT. An escapement for clocks which is now rarely used. It was invented by Lepaute about 1753. It is open to the same objections that the pin pallet is, it being very difficult to keep the pins oiled,

PIVOT. The end of an arbor or shaft that rests in a support or bearing.

Length of Balance Pivots. Saunier recommends the removal of the endstone to see that the pivot projects enough beyond the pivot hole when the plate is inverted. Remove the cock and detach it from the balance. Take off the balance spring with its collet from the latter and place it on the cock inverted, so as to see whether the cock is central when the outer coil is midway between the curb pins. Remove the cock endstone and endstone cap, place the top balance pivot in its hole and see that it projects a little beyond the pivot hole. Place the balance in the calipers to test its truth, and at the same time to see that it is in poise. It must be remembered, however, that the balance is sometimes put out of poise intentionally. See *Poising the Balance*.

The Play of Pivots. Saunier gives the following rules for the play of escapement pivots: In the cylinder escapement, about one-sixth the diameter of the pivot; in the duplex escapement, about one-tenth the diameter of the pivot; in the lever escapement, about one-eighth the diameter of the pivot. A large hole causes the pitching of the depths to vary with position, and a deficient play renders the escapement more sensitive to thickening of the oil. There is less inconvenience when the play is somewhat in excess than when it is deficient. In determining the play of train wheel pivots, proceed as follows: Allow the train to run down, and if it does so noisily, or by jerks, it may be assumed that some of the depths are bad, in consequence either of the teeth being badly formed, or the holes too large, etc. To test the latter point, cause the wheels to revolve alternately in opposite directions by applying a finger to the barrel or center wheel teeth, at the same time noting the movement of each pivot in turn, in its hole. A little practice will soon enable the workman to judge whether the play is correct. The running down of the train will also indicate whether any pivots are bent. It is important that the center pivots project beyond the holes in the plate and bridge.

Shape of Pivots. Pivots must be hard, round and well polished; their shoulders are to be flat, not too large, with ends well rounded off, so that they do not wear the cap jewel. The jewel holes must be round, smooth and not larger than is requisite for the free motion of the pivot which is surrounded with oil. Their sides must be parallel to those of the pivots, so that they sustain pressure of pivot equally at all points of their length. The holes, if of brass or gold, must have been hammered sufficiently hard, so that the pores of the metal are closed to prevent too rapid wear. It is well if the oil sinks are of a size that will

accommodate a sufficient quantity of oil, which, if too little, would soon dry out or become thickened with the worn off particles of the metal. The under-turnings of the pinion leaves are conical, but in such a way that the thicker part be nearest to the pivot, because by this disposition the oil is retained at the pivot by attraction, and does not seek to spread into the pinion leaves, as is often the case, especially with flat watches, in which this provision is frequently slighted.

PIVOT GAUGE. A steel plate with tapered slit for measuring the diameter of pivots.

PIVOT POLISHER. The pivot polisher is used for grinding and polishing conical and straight pivots and shoulders. It is also useful for drilling, polishing or snailing steel wheels, milling out odd places in plate or bridge, where only part of a circle is to be removed, etc. The base being graduated to degrees, it can be set at any angle. The spindle has a taper hole for drill chucks, which makes the fixture very useful for drilling either in the center or eccentric, and by using the graduations on the pulley of the head-stock an accurately spaced circle of holes may be drilled. Fig. 251 is the American Watch Tool Company's polisher; Fig. 252, the Mosely, and Fig. 253, the Rivett pattern.

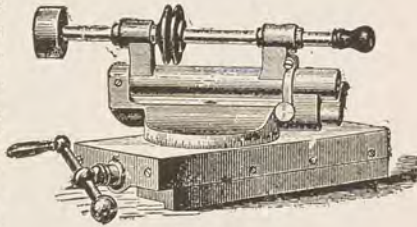

Fig. 251.

The polisher is used as follows: After the pivot is turned to proper shape, put on your polisher (spindle parallel with lathe bed), with lap back of pivot. Use cast iron lap first. (Square corners for square shoulders, and round corners for conical.)

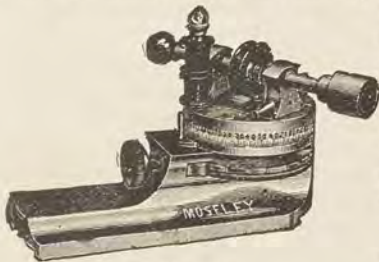

Fig. 252.

Lap for conical shoulder can be readily cornered with a fine file, and cross-grind with fine oilstone to remove any lines made by graver. Lines on end can be removed same way, or in fingers rubbed on piece of ground glass which has on it a paste of oilstone and oil well mixed.

This will rapidly bring them up to a sharp corner nicer than by the graver. On the iron laps

use No. 1 crocus or very fine oilstone powder, well ground down in oil to a paste. When roughed out to your liking, wipe off the crocus, and with a little oil touch the pivot gently; repeat the second time. Then

change lap for one of box-wood, and use crocus No. 4, very fine and ground down to paste. Proceed as with first lap, being careful at all times to keep the lap properly oiled and not pressed too hard against

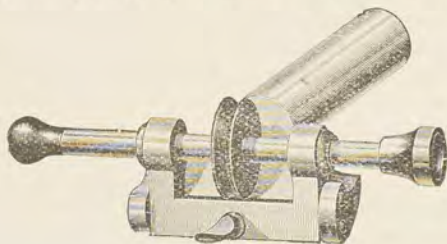

Fig. 253.

the work, particularly in the last operation. Also be sparing of your grinding or polishing material. About three specks of polish with point of small knife is sufficient. Bring the lap up carefully against

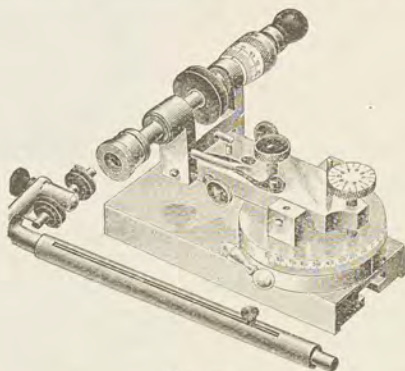

Fig. 254.

the work until spread all the way around, then proceed, bearing in mind that grinding is not polishing, and that to polish nicely the work and lap must be very nearly the right shape. To thoroughly clean the laps, dip in benzine.

Fig. 254 illustrates the Hardinge pivot polisher. It is fitted to the shoe of any lathe so that we can depend upon the zero line being in the right place every time, thus enabling us to get work straight, or to any degree or part of a degree. The divisions on the base are one degree each. The frame is made of steel, being light yet strong enough for hardened bearings for the spindle. Taper-pins are used for joints for yoke of spindle that, being always adjustable and capable of the finest fitting, avoid all lost motion. The spindle is hardened and ground dead true, and has an inside taper, hard also,

and ground true. The angle is $1\frac{1}{2}$ degrees. The outside taper for laps is $1\frac{1}{2}$ degrees also. These tapers are ground while spindle revolves in its own bearings, limiting all error to one operation and thus making spindle as true as it is possible to have it. The raising and the lowering of the lap above or below the center of the lathe spindle is easily accomplished by the two screws. And one screw is divided on top, enabling us to get it to the same height as often as is required. Each division on the micrometer on the spindle reads $\frac{1}{35000}$ part of an inch, or $\frac{1}{1100}$ mm. This micrometer gives us a very delicate and important feed when spindle is at right angle to lathe spindle. When spindle is parallel to lathe bed, a very delicate feed is obtained by the screw under the micrometer a little to the left. This screw presses against a movable inclined plane and is reacted upon by a spring, making it respond to the least movement of the screw and



Fig. 255

Tapers for Inside Grinding.



Fig. 256.



Fig. 257.—Laps.

gives us a fine feed at right angles to micrometer feed. When using emery wheels, revolve wheel so it throws cuttings down, thus keeping it out of the bearings of the spindle as much as possible. Never use a carborundum wheel with this polisher as the particles that are thrown off will settle in the spindle and imbed themselves in and ruin the journals. Diamond dust or carborundum powder can be used, just as well as not, without any damage to tools, but such material must be moistened with oil to keep it from flying in the air, and we must be very careful to keep it only where it is wanted for cutting. Mount the polisher on lathe, with its spindle at right angles to the lathe spindle. Raise it so as to bring the center of the lap considerably above the center of the lathe. The lap used should be of fine brass or soft bell metal, cylindrical in form, and faced flat in front. It need not be filed over the top, as it is used only on its front face. The elevation of the lap above the center must be such that, when the front face of the lap is pressed against the straight side of the pivot, the circular edge of it should fit the cone desired to be produced. With such a position of the lap, the cone will be produced and polished by the edge of the lap, while the front face of it will produce the straight side of the pivot. Diamantine mixed with oil is the best polishing medium for this purpose. Take a little of it on a small spatula and apply it as necessary during the process. Never use any

grinding powder as the diamantine works fast enough. It is well to reverse the motion of the lap at short intervals. This has a tendency of keeping the polishing medium in the right place and works faster. Frequent measuring is necessary in order not to make the pivot too small. When giving the finishing touches slightly vibrate the lap forward and backward along the pivot to insure a straight side. Use moderate pressure on the lap spindle. Attention must be paid to the motion of the lap, which, in all cases, must be the reverse in direction, at the touching points, from that of the pivot. The principal thing is to keep the laps true and sharp, and the corners intact, on frequent facing and undercutting, whenever grinding is to be done.

PIVOTED DETENT. A detent which is mounted upon a pivoted arbor around which is a small spiral spring which causes it to return to the locking position.

PLATE. In a watch or clock the plates form the framework of the movement and in which the holes for the pivots of the train run. The plate in which the pillars are fastened permanently is called the lower or pillar plate, while the removable one is called the top plate. Watches are known as half, three-quarter and full-plate watches, according as the top-plate covers half, three-quarters or all of the lower or pillar plate. In the full-plate model the balance is mounted on the upper side of the top plate, while in the half and three-quarter plate it is mounted upon the pillar plate, thus making a thinner movement.

POISING TOOL. A tool consisting of two parallel jaws mounted upon a base in such a way that they may be opened or closed to suit the length of the arbor of the piece to be poised. When using the tool it must be perfectly level.

POLISHING. See *Cleansing, Pickling and Polishing*. For polishing of steel, pivots, etc. See *Steel, Pivots, etc.*

POOLE, JOHN. An English chronometer maker of considerable fame and the inventor of the auxillary compensation which bears his name. He was born in 1818 and died in 1867.

POTENCE. A bracket used for supporting the lower end of the balance staff in full plate watches.

POTENTIAL ENERGY. Ability to develop power. A weight or spring when wound possesses potential energy or power to do work. The force multiplied by the distance through which it can pass is the amount of potential energy possessed.

PUMP CENTER. The small, pointed steel shaft in the center of a universal head, which is used for centering the work.

PUSH PIECE. The movable part of a pendant used for opening the case. The small movable projection on the side of a case which is pushed in when setting the hands.

QUARE, DANIEL. Born in 1632 and died in 1724. He was the first to apply the concentric minute hand to watches and clocks and was the inventor of the repeating watch.

QUARTER RACK. The rack in a watch or clock which strikes the quarters.

QUARTER SCREWS. The four timing screws in a compensation balance.

RACK LEVER. A watch escapement, said to have been invented by Abbe Hautefeuille in 1734. The lever terminated in a rack, which worked into a pinion on the balance staff.

RAMSAY, DAVID. Clockmaker to James I, and the first master of the Clockmakers' Company. He died in 1655.

RATCHET. A small lever working freely upon an arbor which engages the teeth of the ratchet-wheel and prevents it from turning backward.

RATCHET SPRING. The spring which actuates the ratchet.

RATCHET WHEEL. A wheel having sharp angular teeth into which the ratchet engages to prevent the arbor upon which it is mounted from turning backward.

RATING NUT. A nut placed upon the pendulum rod to complete the timing or compensation.

RAYMOND, B. W. A Chicago capitalist and the first president of the Elgin National Watch Company. The first movement turned out from the factory, April 1, 1867, was named the B. W. Raymond, in his honor. This movement was a success from the start and has done much toward establishing the reputation of the Elgin Company. Mr. Raymond died April 5, 1883.

RECOIL ESCAPEMENT. An escapement in which the teeth are pressed backward, or recoiled by the pallets, after coming to rest, as in the Anchor Escapement.

RED STUFF. Sesquioxide of iron, used for polishing brass and steel by mixing with oil. Crocus, rouge and clinker are various grades of red stuff.

REGNAULD. One of the first French clockmakers who attempted to compensate a clock against the effects of heat and cold.

REGULATOR. The small steel hand or lever to the shorter end of which the curb pins are attached, and which by moving from side to side practically shortens the hairspring. (See *Curb Pins*.)

2. A standard clock having a compensating pendulum and used for timing watches and clocks.

REID, THOMAS. Born in 1750 and died in 1834. He was a celebrated Scotch horologist and the author of a treatise on watch and clockmaking.

REMONTOIRE. A kind of escapement in timepieces, in which the impulse is given to the pendulum or balance by a special contrivance upon which the train or wheel work acts, instead of communicating directly with the pendulum or balance.—*Webster*.

REPAIR CLAMPS. The magic repair clamps shown in Figs. 258 to 260, are used for holding various kinds of work in position,

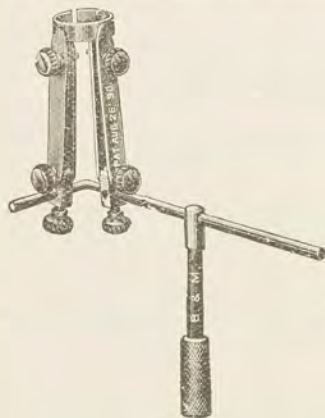

Fig. 258.



Fig. 259.

while repairing, soldering, etc. In addition to the uses shown in the illustrations, it is also applicable for dozens of operations that will suggest themselves to the possessor.

It is so arranged that the end screws can be used as feet and the handles as a support (as shown in the illustrations), so that the tool with the work in it will stand up, leaving the operator free to use char-

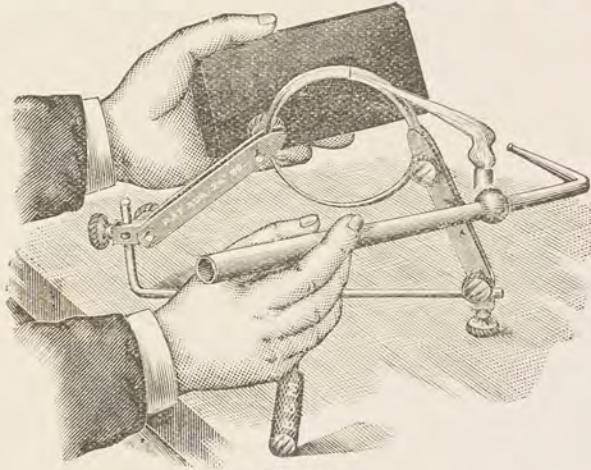

Fig. 260.

coal or asbestos block with one hand and the blow pipe with the other. It is especially valuable for holding dials, when soldering on feet.

REPEATER. A watch which indicates the time by repeating it by means of gongs or bells. There are hour, quarter, half-quarter, five minute, and minute repeaters. They were first made about 1676, and are said to be the invention of Edward Barlow, a clergyman. About the same time Daniel Quare, a watchmaker of London, was working on a model of a repeating watch. Barlow applied for a patent on his invention and Quare, hearing of it, determined to resist him, and succeeded in getting the backing of the Clockmakers' Company, who petitioned the king not to make the grant until the council could see and examine Quare's watch. The council investigated both watches and finally decided in favor of Quare, his watch having but one push piece, while in Barlow's there were two. The principle of all repeating watches is the same, though some arrange the parts somewhat differently.

Repairing Repeating Watches. We will review the various kinds of repeaters we have met with, commencing with the simplest type, viz., the modern quarter repeater. Of these, we will call attention to two varieties. The first of these differs only slightly in construction from the other in one or two points, which are as follows:

The running train of one ends with a pinion, which has sometimes mounted on its arbor a collet of brass to act as a fly in a clock (but often without this controlling medium), but always having a movable plug in the top-plate into which the pivot works, and which is used to regulate the speed of striking, by adjusting to the requisite position, being the same method as applied to an ordinary French striking clock. The second variety has the running train terminating with a pair of pallets, through which the escape wheels run freely, being controlled in speed by a banking piece attached to the pallet staff, and banking on a pin placed in an upright stud in the pillar-plate, which stud can be adjusted in the same manner as in the case of the movable plug in the previous case.

The former style of terminating the running train is found in earlier specimens, and is the only method used in English-made repeaters, while both methods have been used in foreign watches, though we think the former will most generally recommend itself, owing to the unpleasant noise caused in the running of the latter type.

The most simple and easy of readjustment is undoubtedly the Swiss type or bar movement, rendering it possible to take out either the whole or a portion only of the repeating work, in case of some slight correction being requisite, or to apply a new mainspring, either to the going or repeating train, as may be required, without necessitating the taking of the entire watch to pieces (which is inevitable in the old type of both English and French watches.)

We think we do not exaggerate in saying that far less difficulty in readjusting complicated watches and putting together after cleaning, would be experienced, if workmen would make it a rule to observe more care in taking to pieces, and note any little fault, rather than rush the watch to pieces, and trust to chance that, after doing the cleaning, it would go together and be right, as a matter of course, as a little extra care in this way is really time saved. One thing we would try to impress upon all is to exercise special care not to bend or burr the pivots or teeth, or burr the pivot holes, as this is easily done in a desire to complete the work in hand, and often causes much vexation and loss of time and temper, when a very different result can be attained with ordinary care and forethought. For instance, the careless mixing of the screws belonging to the various portions of the work is a thing to be particularly avoided; this may appear to be a trivial matter, but experience has taught us that it is a very serious one. It has been our lot to take up work, previously commenced by others, and either through their incompetency or carelessness, our lot has been rendered anything but a happy one; even the simple task of taking the movement roughly or thoughtlessly out of its case, thereby distorting the gongs, will cause one sometimes to waste hours on readjusting, where a few minutes extra spent in the

first instance would have obviated this trouble entirely. Of course, in the Swiss style of repeater, where the gongs can be easily removed from the watch before taking the movement out of the case, there is no reason why they should receive the slightest injury, but in this it is quite likely that your screws becoming mixed would cause great trouble and loss of time and worry, as the result of a little want of care and forethought. We would also impress upon each the necessity to be sure that none of the numerous studs which carry the repeating work are either bent during cleaning, or left with the dirty, thick oil adhering, and also that they are not loosened in the process.

We will now pass on to note points of difficulty arising through ordinary wear and tear such as, for instance, the enlargement of the pivot holes of the hammers and of repeating barrel arbor holes, whereby slight inaccuracies will be caused in the repeating of the hours, etc., aggravated by additional wear having taken place at the points of action of the star wheel (to which is attached the hour snail), causing wrong numbers to be struck; though, perhaps, it is hardly fair to attribute these faults to wear alone, as they are often caused, or at least intensified, by the stupidity of some previous operator in making alterations (for what reason is more often than not a mystery). It is no uncommon thing to find the star with the teeth (or points) bent, some in one direction and some in another. When this is the case, the hitch will generally be found, on testing, that some of the hours are not giving the correct number. The plan we adopt is to at once set them upright, and with few exceptions, obtain the result desired.

In many of the older types of repeaters, the hour rack (or ratchet) is in a piece with the barrel arbor and consequently between the frames, as is likewise the pallet attached to raise the hammer for the hours. We therefore must observe great care in putting together, to avoid the necessity of again removing the plates. As this entails much extra work and loss of time, it is therefore necessary to pay especial attention to see that we have the pallet aforesaid in its proper position on the hammer arbor, and also to be sure that the mainspring hooks in both going and repeating barrels are properly adjusted, so that there shall be no slipping from their anchorage at an inopportune moment. This, of course, will happen at times with even the best regulated workmen, but a little attention to these points at this stage will prove very valuable in the result, as to have to pull your work apart again means spoiling it in appearance in point of freshness, as the oil gets spread about, besides picking up particles of dirt, which means brushing out again, at least some of the work.

We will now consider screws, badly fitting, or with an inclination to overturn. Do not attempt any tinkering with them, but proceed to fit a new one at once, even if you have to resort to making a tap for

the purpose, and turning down a piece of steel for a screw; you gain the desired end in a workmanlike manner. And in performing so apparently simple a thing as fitting a new screw, be careful to remove any burr caused by re-tapping the plate, as to have a spring or other portion of work displaced through negligence of this kind does not give your watch a fair chance of performing properly; also observe that all steady pins (in springs, etc.,) are secure and doing their allotted work.

Another very important point is to utilize the full length of repeating mainspring in a judicious manner by setting up as fully as possible (without, of course, making it strain on the hook at top), thus giving equal power all through the striking, or often you will find the quarters dragging slowly to a finish; and if this is so when the watch is fresh oiled, what will it be in six months after? This applies, of course, with greater force to the minute repeater, which has more to accomplish. Another plan we always adopt is to just run our eye over every separate piece to make sure each wheel is secure on its pinion, as it often happens that in brushing out they get loosened, or a bristle gets broken from the brush and sticks in a tooth or under a stud or other crevice, causing great annoyance if not observed at once.

Other points to note and carefully readjust are the main wheel of repeating train, to see that it revolves freely on the arbor, as in drawing the slide to repeat, it is important that it should remove smoothly without jerking; the same applies in respect to the slide-work in the case, which is often choked with dirt, and (where there is no spring to throw back) either slide or rack causes great impediment in striking. And, again, in this connection observe care in cleaning the case, that no damage is done to groove in which slide acts, as the slightest bruise on the edges may prove a great puzzle. Be sure also that the star wheel shifts freely and does its work in a decisive manner, as likewise the loose piece on quarter snail, which is moved by flirting of star wheel, and which, acting properly, gives (at the hour) the hour only. See also that the quarter snail is not loose, but firmly riveted to canon pinion, and running perfectly flat to insure rack-tail falling securely, as it must be borne in mind that the space at command as a rule is very limited, more particularly in the modern watches, and notably in minute repeaters. One very important item is the set arbor, to mind that it acts smoothly and yet firmly, not loose in one place and tight in another. This applies to both the watch with hollow center pinion, with loose set arbor, or to solid pinion on which canon revolves. This is one of the points, even in the ordinary plain watch, which receives most unmerciful treatment at the hands of the botch, and yet is of the utmost moment to the good and correct performance of every watch, and especially the repeater.

Instead of such reprehensible methods as are so often resorted to—viz, the rough and ready use of nippers or graver to burr the arbor, or, as one frequently sees, the flattening even by the use of the hammer—the best plan, and one sure to give satisfaction, if tried, is to first remove the burrs by revolving the arbor in the lathe, using a polisher charged with oilstone dust. Having done this, lay the arbor on a brass stake, and with a fine sharp pointed center punch raise a swelling on it at the spot which will be nearest to the middle, so giving a firm and yet smooth action; at the same time it is necessary to observe that it does not work too tightly, or there is danger of backing the escapement in reversing the hands. One type of repeater seldom met with is the *five-minute repeater*, that is, one which, after giving the hour in the usual way, gives one stroke for each five minutes recorded by the hands, so that, for the sake of illustration, say the watch shows by the dial five minutes and less than ten minutes past the hour, viz., nine minutes past three, you would, on repeating, get first the hour, three strokes, and then one stroke, and at ten minutes past you would get two strokes, and so on, an additional stroke for every five minutes up to within a fraction of the next hour, when you would get eleven strokes, when, immediately on completion of the next hour, you would get four strokes, viz., four o'clock. This, to our mind, is of greater utility than either the quarter or half quarter repeater, and far less complicated and certainly less costly to produce than any other type, and serves every purpose for which a repeater is required, as to be able to ascertain the time in the dark within five minutes is assuredly near enough for any one. To arrive at this you have the ordinary hour snail affixed to star wheel, and in place of the usual quarter snail on center arbor there is one with eleven divisions and a rack with the same number of teeth to give the strokes one to eleven as required.

We have known several instances of workmen and others who, coming across one of these for the first time, have imagined (and not unnaturally) that they were in possession of a minute repeater, which was giving the hours and minutes while the quarters were failing to act, but on removing the dial were agreeably surprised, besides gaining fresh experience, thus showing that we in the watch trade are always learning. Fig. 261 shows the rack which produces in turn both quarters and half-quarters. It is hardly necessary to point out that the quarters are produced by the six teeth (three each at opposite extremities), alternately raising the hammers at equal intervals. We will commence with the first half-quarter. It will be seen by reference to Fig. 261, that there are apparently three teeth at one end and four at the other; this shows the rack in position for giving the half-quarter only. The tail of rack, which falls upon the snail, Fig. 262 controls this by allowing it to fall just far enough to pass back beyond

the first pallet, in readiness to raise the hammer on its return, thus producing one blow at the half-quarter, whereas on reaching and passing the fifteen minutes past, the four teeth will only appear as three, as the lower half of the rack tail now falls on the under part of the snail; this result being attained by means of the loose shifting piece attached to the rack, and controlled by a click and spring. And in this shifting piece generally arises any failing in the half-quarter, as should the said click spring be set on too strong, or, on the other hand, not strong enough, you will be either without your half-quarter or else get it when you should have the full quarter. This failure is also partly in consequence of the spring of the rack not being set on quite strong enough, as in the case of any slight impediment the tail of the quarter rack would only reach the quarter snail in falling, instead of getting underneath it on to the half-quarter snail; this might also arise in consequence of excessive endshake of the center



Fig. 261.



Fig. 262.

wheel, bringing the canon pinion too low, which would complicate matters further by causing the snail to foul the star wheel. If these important points are carefully attended to there will not be much fear of failure, always, of course providing there has not been any tampering with the snail or the rack, or more especially with that portion of the rack which controls the giving or withholding of the half-quarters, as is unfortunately the case sometimes, though happily not often. We are convinced that as a rule, where any alteration in shape of any part from the original has been made it is merely experimenting, and once indulged in leads to mischief and utter failure.

In all our experience we can only recall one instance of a watch of this particular type, an old duplex half-quarter repeater by McCabe, which appeared likely to master all our efforts to get the half-quarter to act properly, and though we felt convinced we should be justified in altering the shape of the half-quarter rack at the point of contact

with the click which controls the shifting of the same, we were loath to do so, as there did not appear to have been any serious tampering with it, though undoubtedly the shape had been slightly altered. We however, did at last make the alteration according to our conviction in the matter, but not before we had given it every consideration, and taken counsel with others, and were gratified to find we obtained the exact result required, and did not therefore, consider the loss of time a waste of time.

Of course, there is no hard and fast rule in watch work, and the fault met with in the job today may not present itself again for years.

There is one thing to be said in favor of the half-quarter repeater; and that is, that it was made principally in the good old times, when plenty of time was devoted to the work, with a view to durability; and consequently faults do not arise as a rule from absolute wear, as the endeavor seemed to be to put in the finest material, at the same time

making it of the best possible temper. Indeed, this applies to all the old watches as regards the quality and temper of the material, as any reader is aware who comes across a specimen from time to time. This is, unfortunately, a very different character than can be given in the majority of work of the present day, where the demand is for cheapness, the result being that you get the steel work absolutely soft, and of course in this state it is impossible to impart the same amount of finish to the work, hence



Fig. 263.

roughness in the action and speedy signs of wear in parts of contact.

Fig. 263 shows an old specimen of a French quarter repeater, apparently of very ancient origin; the movement and dial bear the name Chevalier and Compagnie. It has a verge escapement, and repeating was pushed from the pendant as was customary with all the earlier specimens; it has also the chain connection from the gathering rack at pendant passing around a roller *A* near the edge of plate, and attached to and passing around a smaller roller *B*, on the square of the repeating barrel arbor.

It will be seen that the quarter rack is minus a tooth at *C*, and has the two remaining teeth mutilated; it is also minus one of the quarter pallets, and the hook has disappeared from the square of the repeating barrel arbor by which the quarter rack should be gathered; all indications that it has been in the hands of the Philistines.

The hour rack is in a piece with the barrel arbor, and consequently between the plates as mentioned in a previous paragraph.

Another indication of the antiquity of this specimen is the fact of the winding or fusee square coming through the dial. It will also be observed that the "all-or-nothing" piece, *D*, is pierced to admit of the fusee square and key-pipe passing through for winding. One of the greatest difficulties met with in this type of repeater arises in the event of the breaking of the chain connecting the gathering rack for winding up the repeating mainspring, as great care is required in repairing the same to re-adjust to the proper length again, and can only be accomplished with great care and trouble, and probably with many failures; the endeavor should be to manage as near as possible to obtain links of chain to replace those spoiled, as near to size as you can to those remaining.

It will be seen that the star wheel, to which is attached the hour snail, is carried by the "all-or-nothing" piece, and when displaced by the gathering rack is capable of a small recoil which releases the quarter rack; this is modified in the more modern repeater by the star piece revolving on a stud fixed in the plate, and the "all-or-nothing" piece shown here is replaced by the *spring* "all-or-nothing," which we will endeavor to show and describe, as also we will endeavor to show the movement of a half-quarter repeater from which the rack and snail shown here in Figs. 261 and 262 are taken.

The following figures show the movement from which rack and snail are taken. We have not replaced either the said rack or snail, as they would have hidden the other pieces which we wish to draw special attention to on this occasion. Our object is to show clearly firstly, the gathering rack *A*, and secondly, the intermediate wheel *B* which gears into the teeth of former, and also the smaller wheel on square of repeating barrel arbor, for winding up repeating mainspring, being more modern and a great improvement on the old system as represented in the ancient specimen, having chain connection, as previously shown. One point, subject to injury, (and which requires careful treatment to readjust), is the shoulder screw which secures the intermediate wheel, and very little reflection will convince the thoughtful that the careless fitting of a new screw here would soon lead to difficulty, as being a cross or double depth it complicates matters somewhat, and any roughness here would cause jerking in gathering or winding, and also cause strokes of the hammers to be given in a spasmodic manner, but of course this can all be avoided if care is exercised in retapping plate not to alter position; should the depths, however, get shifted, the best plan to adopt will be to repitch them, using the depth tool for that purpose. We should next like to call attention to the slidework of above figure, our reason being that having originally been pushed from the pendant, the winding up of

repeating is now done on the modern principle, viz., with the slide (the movement having evidently been put into a new case at the same time). Our desire is to especially call attention to the manner in which the conversion has been accomplished, so as to enable any reader to adopt the same method in case of requirement, as although we have seen several which have at some time been transferred, we never saw one which had been done in so simple, and at the same time so thoroughly workmanlike style. Fig. 265 is somewhat of a snail-shaped piece introduced into the pillar plate below the gathering rack, and having a sink turned to receive it. It will be seen by referring to figure of movement, that we have pressed arm or tail of gathering rack on to hour snail in readiness to be released for striking the hour of five, this allows snail-shaped piece (Fig. 264) to be readily seen, showing outside extremity of same projecting beyond outer edge of movement (and which engages with slide in case), while the



Fig. 264.

inner point is engaged in depressing gathering rack at *C*, where pressure originally came from pendant pushpiece, being in reality the reverse end of tail rack mentioned above, and being securely fixed to same by means of screw and steady pin on under side.

The hour rack, or ratchet *D*, being in this specimen (unlike the former one) separate from the barrel arbor, is seen above the plate; screwed on to it is a nut gearing with intermediate wheel for winding, surmounted by hook for gathering quarter rack, each of which are fitted on to square of barrel arbor, hook and square being drilled across with the pin passing through to secure them in position. Having fixed the whole in readiness, on being released to repeat the hour of five, as before mentioned, allows of the whole twelve teeth of the hour rack or ratchet *D* to be clearly seen, with the pallet engaged (when released) for raising hammer to give the five strokes required, and also gives a fair view of the star wheel, and likewise hour snail, with rack tail *E* pressed onto the fifth step or division of snail. The "all-or-nothing," being capable of a slight recoil, release the quarter rack, and after striking returns into position and remains locked until the slide is again drawn, and so on as often as desired, hence the name "Repeater." And now for a description of the more modern or spring "all-or-nothing," as shown in Fig. 266.

It differs from the old considerably in form, and as it undoubtedly is much less complicated in construction, we must admit its superior-

ity over the former, and though differing in form the action is very similar. The star wheel and hour snail, in place of being carried by the "all-or-nothing," is revolving on a fixed stud in the plate, and the quarter rack is released by pressure being transmitted from arm of gathering rack through a small finger being driven into contact with the "all-or-nothing" at its thickest part at the moment of the slide being drawn back to its full extent. The pressure given causes the "all-or-nothing" to give at its thinnest part which forms a spring, hence the term spring "all-or-nothing." The rack arm in this type is not made in a piece with the rack, but is made separate from it, and until recently was attached (as is also the finger) by means of a shouldered screw, and both rack and arm have an elongated slot in them, thus permitting of a slight backward and forward movement to the arm, so that when the arm comes in contact with the snail, being capable of this action, it is driven backwards, and having an upright stud at the reverse end, which immediately makes pressure on the small finger, which is also driven backwards, and its extreme point touches the "all-or-nothing" at its thickest part, causes it to recoil by means of its spring, thus releasing the quarter rack in the same man-



Fig. 265.



Fig. 266.

ner as in the previous case. The latest method is to make the gathering rack and arm in two distinctly separate pieces, but both operating from a fixed stud in the plate and accomplishing the same result precisely, and in a very similar manner; the latter type is probably the outcome of necessity, in consequence of the repeater being required to strike the minutes in addition to the hours and quarters, as it permits of the various parts being made on a smaller scale, thus utilizing the room required for the increase of complications.

The fault we will first call attention to is a troublesome one, though fortunately one not frequently met with; it is the two blows of the quarters following each other so rapidly as to appear almost as one blow.

To remedy this it will be necessary to lengthen the three teeth of the quarter rack which raise the hammer giving the last blow to each quarter; or it may be that only one or two of the teeth will require lengthening. This must be accomplished by stretching, which can be done by laying the rack on a smooth steel stake, having the under side of the rack uppermost; and by using a rather sharp rounded

punch (having someone to assist with the hammer), a very creditable job can be made of it; and as very little stretching will probably be required, there need be no disfigurement of the rack if care be exercised. In most cases there will be no fear of accident either, the only chance of this being where the watch is one of the good old sort, when there would be great risk of breakage, in consequence of the high temper of the steel; it will therefore be wise to first test the piece to see whether it be very hard, and if so, the temper must be lowered by bluing, and the color afterwards removed.

This fault is generally the outcome of wear at the points of action of the pallets and rack teeth, or the enlargement of the holes of the hammer pivots, and might be remedied by new holes or new pallets; but as the latter would be too long and costly a process in ordinary repairing, we must be satisfied to resort to the more rough and ready method mentioned, and stretch the teeth; but before doing this it will be advisable to make sure that the fault is not caused by the stud which carries the quarter rack being loose in plate, or having got bent, thereby throwing the rack out of position, as this of course



Fig. 267.



Fig. 268.

would create the fault in question. It will be remembered that we have previously called attention to the liability of the studs getting bent in the process of cleaning, or putting together after the cleaning is done, so that these points should be looked to before making any alteration in the rack teeth.

It will now be our endeavor to give some details of the minute repeater, which in consequence of its additional complication is necessarily more puzzling, and when faulty, more difficult of correction than the others already passed in review, and before proceeding further we would impress upon our readers the desirability of giving special attention to endshakes, above all in respect to center wheel, as likewise proper fitting and smoothly revolving set arbor. It will be seen by consulting Fig. 267 that the quarter snail has secured to it a four-armed piece which would undoubtedly be properly called "the surprise piece," and which is actuated by a click in all respects similar to the star wheel click; this four-armed blank, or "surprise piece," together with the quarter snail attached to it, is keyed onto

set arbor, but in such a manner as to act freely to and fro within proper limits, and above this, and secured to set arbor, beneath the canon pinion, is another four-armed piece, but very much differing from the "surprise piece," insomuch that it bears upon each of the four arms a set of fourteen teeth, and which we will call the minute snail, Fig. 268.

The necessity for each of these fourteen teeth or steps of the snail are obviously for the minute-rack tail to fall upon and so control the number of minutes to be struck in addition to the hours and quarters, the four-armed or "surprise piece" acting, as in the case of the corresponding piece previously described, as "loose piece or quarter snail," this surprise piece of course giving or withholding the minutes as required. Figs. 269 and 270 show the quarter and minute racks respectively, the former differs considerably from the ordinary quar-

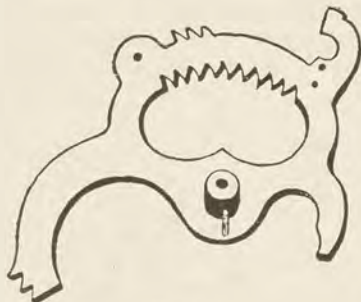

Fig. 269.

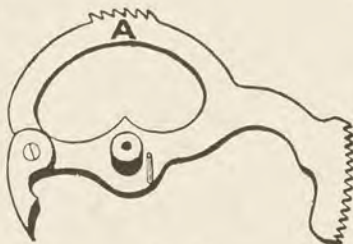

Fig. 270.

ter rack, having in addition to the six teeth for raising the hammers, three at each extremity, an internal set of teeth, and for gathering this quarter rack by means of these internal teeth is a disc with a corresponding number of teeth. This disc, revolving freely on the arbor of repeating barrel, has an upright pin fixed about midway of the teeth, and surmounting this disc on the square or barrel arbor is the rack hook, the point of which on completion of the striking of the hour engages with the upright pin and so gathers the quarter-rack.

Attached to and working freely by means of a shouldered screw is what we will call the minute "all-or-nothing," Fig. 271, as without it the minute rack would not be released to fall into position on the minute snail; but besides acting as the "all-or-nothing," it also does duty in another capacity, viz., to gather the minute rack, this being accomplished by the lower extremity, which in shape is not unlike an ordinary side click to a Geneva barrel, or hook-shaped, and is in reality the minute rack hook, and is controlled by means of a slight

spring, which at the proper moment brings its point or hook into one of the six small teeth at *A* according to the number of minutes required to be struck. The upper portion of this piece, Fig. 271, is really the minute "all-or-nothing," as on the falling of the two racks, the point of this minute "all-or-nothing" in its descent strikes on the hammer pivot, or arbor, which stands above the pallet, and so raises or displaces



Fig. 271.

it from the teeth at *A*, thus allowing the tail of rack to fall upon the minute snail (according to position of the latter), then on returning, the hour and quarters having struck, this upper portion, or "all-or-nothing" disconnecting from contact with pivot or arbor of hammer allows the front or lower click, or hook-shape portion, to fall into one of the teeth at *A*, and so gather the minute rack.

It will be seen that this rack, besides the teeth at *A*, has fourteen other teeth at another extremity, this being the necessary number to correspond with the number of blows required between each quarter of an hour, and of course have the same action of raising the hammer as in the case of the hours and quarters.

The amount of work to be accomplished with precision by a minute repeater will show how soon inaccuracies can occur if due regard be not paid to important points; for instance, we will suppose that either of the center pivots are cut, and require the wear polished out, and new hole or holes put in; a little thought will clearly convince one of the necessity of exercising the utmost care in the operation, as to throw the wheel out of upright, in ever so slight a degree, means mischief, and to leave a large hole is out of the question, especially with the pivot cut, which, of course, increases the friction, causing a loss of power, and consequently bad time-keeping, besides the speedy failure of the oil.

A good method of putting in a new hole is by means of a turned bushing, and for this purpose avoid the use of the drilled brass, which invariably splits either in turning or riveting, and brings about the very trouble you wish to avoid; the solid drawn wire is the thing for the purpose. Cut the required length, drill as near central as possible, and open tightly on to pivot, (which has first had the wear polished out). A word here will not be out of place about repairing the pivot, as though the primary object is to polish out the wear, there are other points to be observed; in the first place, be sure to keep it straight, as, to get a pivot tapering either backwards or forwards, makes it impossible to get a good fitting hole, which at the same time will allow the wheel to act with perfect freedom, both as regards the running and endshakes. At the same time avoid forming a lump at the root or shoulder; should this by chance transpire, however, mat-

ters can soon be set right again by means of the lathe and polisher in a few minutes, and having polished out the wear, take a sharp graver and catch the merest shaving from the extremity of the pivot, to prevent the possibility of a burr remaining, as this would cause the pivot to stick in the hole.

In broaching out the old hole before putting in new bushing, revolve the plate and broach together, of course, in opposite directions, as this will materially assist in opening out true and flat. In fact, by occasionally spinning the broach in the fingers, it can readily be seen whether you are keeping a straight or upright hole; this applies more forcibly, when finally opening the hole for the pivot.

In fitting a bushing into a plate, before removing from the arbor on which it has been turned, be careful to catch each end perfectly true, the back quite flat, and the front slightly hollow for riveting. Do not turn it tapering forward too much, and, above all, do not have it longer than just sufficient for riveting, and fitting so tightly as to necessitate knocking into plate preparatory to riveting, and before knocking in give the broach a slight wriggle to rough the hole, or it can be roughed with the edge of a three-cornered file.

The bushing, or plug, must, in all cases, be put in from the inside of plate, giving a slight chamfer to outer side to allow rivet to grip more firmly.

Having made the bushings secure by carefully riveting, without .oo violent use of the hammer, and opened the hole to pivot, it only remains to give endshake, and to do this properly requires a lathe, and either the use of a hand-cutter or the slide rest; though if a lathe is not available, good sinking tools make a fair job.—*C. T. Etechells.*

To Bend Gong Wires. The bending of a gong wire in a repeating watch, in order to free it from any point it touches, often results in diminishing the sound considerably. In such a case, Immisch advises as follows: If the spring touches on the outside and must consequently be bent inward, it should be laid upon a convex piece of brass corresponding in shape with the inner side of the spring at the place where it is to be bent; then, if the outside be slightly hammered with the sharp edge of a hammer, the small indentations produced will cause the outside to lengthen a little and the inside to contract in proportion. The time required for the shape to become permanent differs greatly with the degree of elasticity. It is sometimes desirable to bend a spring, but the repairer, being afraid of breaking it, abandons the idea. Suppose it is desirable to bend a side click spring of a Swiss bridge watch, which, by the way, is generally made of poor steel. Take hold of the end in which the screw goes with a pair of brass-nosed sliding tongs, holding it in the left hand; then press a piece of brass against the click, bending it in the direction desired, and at the same time holding it over

the flame of a spirit lamp until the center, or spring part, becomes a straw, or dark red color. The fact that spring-tempered steel is brought to a dark red-blue twenty times over, will not reduce it below its former temper; on the contrary, it will tend to equalize and improve the temper, and render it less liable to break. Suppose a cylinder pivot, or any pivot of the escapement parts are bent, and you wish to straighten it by this process; take a small brass ring, fit it to the pivot and hold over the flame of the lamp, bending it at the same time in the desired direction.

Repeating Attachments. Fig. 272 illustrates the repeating attachment recently patented and put on the market by the American Repeating Watch Factory, of Elizabeth, N. J. The complete mechanism is arranged on a small plate which can be fastened to any of the American made movements by the aid of a few screws, and the construction is such that it can be wound either by the stem or by the repeating slide, the latter being similar to those used on all Swiss repeaters. The stem winding pattern can be applied to Elgin 16 size hunting, Illinois and Dueber-Hampden 16 sizes, Waltham 14 sizes and Lancaster 18 sizes, all hunting movements. The repeating slide style can also be applied to these watches. The slide pattern is adapted particularly to Elgin 16 size open face and Elgin interchangeable 16 sizes and to Waltham and Columbus 16 size hunting and open face, Waltham 14 sizes, Illinois 16 sizes in open face, Howard 16 and 18 sizes and Paillard non-magnetic watches, both open and hunting. The attachment can also in various ways be applied to other American and Swiss watches. Fig. 272 represents the attachment



Fig. 272.

applied to an Elgin 16 size hunting movement. To attach this mechanism to a watch, first wind its mainspring completely and then let it down only one-quarter turn. Set stop wheel in position with its shoulder against the stop piece, to prevent further winding, place both racks above the stop wheel and let the mainspring drive the parts back to their normal position. The lever winding parts are arranged under the repeater plate and are similar in construction to those used in Swiss repeaters. The stemwinding connection is composed of a ratchet wheel which is geared with the crown wheel of the stem-winding mechanism of the watch, and a ratchet stem, that passes through the wheel and both watch plates, carrying on its other end a pinion, that gears into the repeater barrel wheel, which winds its mainspring when the stem is turned to the left.

REPEATING RACK. The rack in a repeater supplied with teeth by which the hours, quarters and minutes are struck.

REPEATING SLIDE. The slide by means of which the repeating train is wound from the outside.

RESILIENT ESCAPEMENT. A form of the lever escapement in which the lever yields, when pressed upon the outside by the impulse pin, and allows the pin to pass. See *Lever Escapement*.

REST. The T-shaped piece of metal attached to the lathe bed and on which the graver, peg wood, polisher, etc., is rested. It is also known as *T rest* and hand rest.

Back Rest. Among the many tools that watchmakers can make for themselves, one of the most useful is the tool illustrated in Fig. 273. It is a modification of what machinists call a "back rest." The only

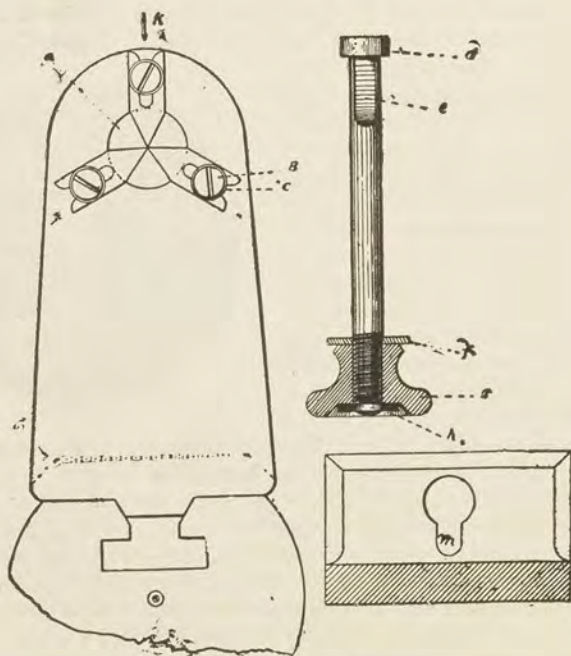

Fig. 273.

points in which it differs from that employed by the machinist is the shape of the jaws and the mode of fastening to the lathe bed. *a* shows the rest in position on the lathe bed, looking from right hand end of

bed; *B* shows the base, looking from above, in direction of arrow *k*; *C* shows bolt for binding it to the lathe bed. It does not seem as though it needed much explanation, as it will readily be seen that the head *d* of bolt, passes up through the longitudinal slot in lathe bed, through the round hole in base of back rest, and slipped back into slot *m*, when about half a turn of the nut *g* binds it firmly to the bed. The washer *h*, on the end of binding screw, is riveted or soldered in place, and should be close enough to nut *g* to allow only about half a turn to loosen the bolt, as that is sufficient, and more would be time lost in running the nut back and forth to bind or loosen the rest. It will be seen that when the nut *g* is slackened it binds against the washer *h*, and it will stay there, and be just where you want it when you want to use it again. The jaws are of hard brass; about three sets, with points of different widths, will cover a good range of work. Those shown in Fig. 273 are suitable for such work as pivoting small French clock pinions, etc. It will be observed that the jaws are so made that they may be changed by slightly loosening the screws. The screw heads should have thin steel washers under them.

RING GAUGE. A gauge used by jewelers for measuring the internal dimensions of finger rings.

RIVETING STAKE. A steel block, pierced with a number of different sized holes. See *Staking Tool*.

ROBIN, ROBERT. A celebrated French watch and clock maker. He built many large turret clocks for the public buildings of France. Born in 1742 and died in 1799.

ROCKING BAR. The steel bar which carries the intermediate wheels in stem wind movements. Sometimes called the yoke.

ROLLER REMOVER. There are numerous designs in the way of roller removers upon the market, but lack of space prevents description and illustrations of them. Fig 274 illustrates the Hardinge remover, while Fig. 275 illustrates the Sheehan. They are both excellent tools and do the work in a satisfactory manner.

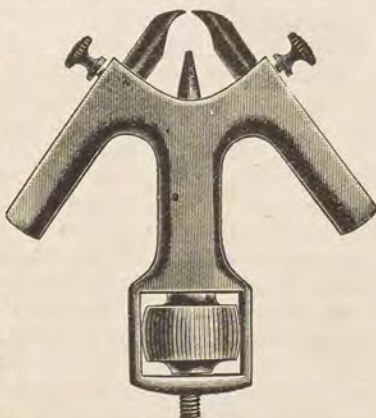

Fig. 274.

ROMILLY, M. A clever Swiss horologist. He was held in high esteem in Paris, where he passed the greater portion of his life. He was born at Geneva in 1714 and died in 1796.



Fig. 275.

ROSE CUTTER. A hollow cutter, as shown in Fig. 276, used for reducing the size of wire, as in forming heads when making screws.

ROSE ENGINE. A form of lathe in which the rotary movement of the mandrel may be combined with a lateral, reciprocating movement of the tool rest, the result being a movement of eccentric character. In this way many curves of an epicycloid or hypocycloid character and of great variety and beauty may be obtained by varying the rate of speed between the lathe mandrel and the lead screw, or splined rod which governs the motion



Fig. 276.

of the tool post in the slide rest. The change gears are handled as in the ordinary engine lathe. Another form of this engine has a very heavy head, formed of a series of disks, circular in form, and placed concentrically on the shaft, so that they resemble a cone pulley having a large number of steps. These disks, instead of being true circles, are formed of a great number of facets, so that the discs constitute polygons of 64, 120, 180, etc., sides. The central mandrel bears an eccentric chuck and has lateral play, so that the facets, striking on a rigid roller, throw the mandrel alternately in and out of center, thus bringing the work regularly to and away from the cutting tool, making the tool cut a lozenge-shaped chip each time a facet on the disc is encountered by the roller. The work being held eccentrically in the chuck, these chips, or digs, are very fine and close at the center, and enlarged proportionately as they reach the outside of the watch case or other object being ornamented.

The work is done with tools which have been sharpened and polished so carefully as to make a "bright cut" on the metal, and the operator turns the lathe with one hand and watches the progress of the work with a glass.

ROUGE. See *Red Stuff*.

ROUNDING UP ATTACHMENT. The Webster rounding up attachment, shown in Fig. 277, is a very useful adjunct to the lathe. It is attached to the top of the slide-rest. To operate, a pointed taper

chuck is put in the lathe spindle. The wheel to be rounded up is put into the fixture and the wheel adjusted vertically so that the point of the lathe center will be at the center of the thickness of the wheel, after which the lower spindle of the fixture should not be moved. Now remove the wheel, also the taper chuck, and put the saw arbor, with the rounding-up cutter, in the lathe spindle, and adjust the longitudinal slide of the slide-rest so that the rounding-up cutter will be back of and in

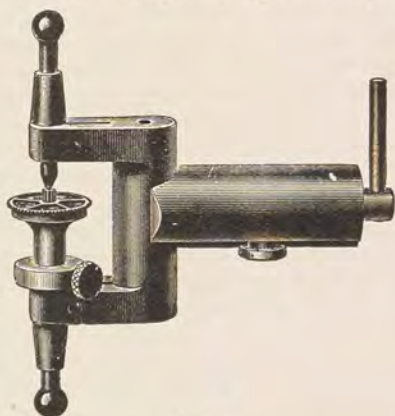

Fig. 277.

line with the center of the rounding-up fixture, after which the longitudinal slide of the slide-rest should not be moved. Now put the wheel and supporting collet in place, and proceed with the rounding-up.

ROY, PETER. Watchmaker to the King of France. Died 1785. Author of two works on horology.

ROZE, A. C. An eminent French watchmaker. Born in 1812, and died in 1862.

RUBY PIN. The impulse jewel set in the roller of the lever escapement.

RUBY ROLLER. The roller in the duplex escapement which locks the escape wheel teeth.

SAFETY PIN. In the lever escapement, a pin that when the hands are turned backward, prevents the pallets leaving the escape wheel.

SAFETY PINION. A center pinion which allows the barrel to recoil when the mainspring breaks.

SAPPHIRE FILE. A piece of flat brass to which a piece of sapphire, previously flattened, is attached by means of shellac. It is used for working upon garnet pallets and other soft stones. The sapphire is ground upon a diamond mill, and its surface rendered coarse, or fine, according to the mill used. A strip of copper and diamantine is sometimes used instead of sapphire files.

SCREWS. Odd sized screws, not to be had from the material dealers, may be readily made by means of the screw plate and rose cutter. The rose cutter is quite a valuable adjunct to the lathe, and is fixed to the spindle in the same manner as the chuck, and will be found exceedingly useful for quickly reducing pieces of wires for screws, etc., to a gauge. For screws, the wire should be of a proper size for the screw heads, and a cutter selected with the hole the size of the finished screw. The point of the wire is rounded to enter the hole of the cutter, against which it is forced by the back center of the lathe, the serrated face of the cutter rapidly cutting the superfluous metal, the part intended for the screw passing into the hole in the cutter. Some care is required in rounding the point of the wire, for if not done equally all around, the screw will not be true to the head.

To Remove Broken Screws. It sometimes happens that a screw gets broken off in a watch plate in such a manner that it is impossible to remove it with tools without marring the plate. In such an event proceed as follows: Put enough rain water into a glass tumbler to thoroughly cover the plate and add sulphuric acid until the water tastes a sharp sour. Place the plate in the solution and allow it to remain a few hours, when the screw will partially dissolve and drop out. Remove from the solution, wash thoroughly in clean water, then in alcohol and dry in saw dust. The solution will not injure the brass plate or gilding in the slightest, but care must be taken to remove all other screws or cement jewels, previous to immersion.

Any one having an American lathe can, with small expense of time and labor, make a small attachment which will easily and quickly remove a broken screw from the plate or pillar of any watch.

Take two common steel watch keys having hardened and tempered pipes—size, four or five—having care that the squares in each are of the same size and of good depth. Cut off the pipes about half an inch from the end; file up one of these for about one-half its length, on three equal sides, to fit one of the large split chucks of the lathe. Drill a hole in one of the brass centers of the lathe of sufficient size and depth, into which insert the other key-pipe, and fasten with a little solder. Soften a

piece of Stubs' wire, to work easily in the lathe, and turn down for an eighth of an inch from the end to a size a little smaller than the broken screw in the plate; finish with a conical shoulder, for greater strength, and cross-file the end with a fine slot or knife-edge file, that the tool may not slip on the end of the broken screw; cut off the wire a half inch from the end and file down to a square that will fit closely in one of the key-pipes. Make a second point like the first one and fit it to the other key-pipe; harden in oil, polish, and temper to a dark straw color. Fit the brass center into the tail stock. To use, put the tools in place in the lathe, place the broken end of the screw against the end of the point in the lathe head; slide up the back center and fasten the point firmly against the other end of the screw, that it may not slip or turn; revolve the plate slowly, and the broken screw, being held fast between the two points will be quickly removed. To remove a broken pillar screw, place the broken screw against the point in the lathe-head, holding the plate firmly with the right hand, the pillar on a line with the lathe center; turn the lathe-head slowly backward with the left hand, and the screw will be removed. Should the tool slip on the broken screw, and fail to draw it out, drill a hole in the pillar in the lower or dial side, down to the screw point (if the size of the pillar from the plate will admit of so doing), and with the second point in the back center, remove the screw in the same manner as the plate screw in the first process. Five or six sizes of these points will be found sufficient for the majority of these breakages that may occur. See *Screw Extractor*.

To Blue Screws. See *Blueing Pan*.

Left-Handed Screws. A screw plate for left-handed screws can easily be made by screwing a good piece of steel of the desired size into a right-handed screw plate, removing, filing down on two sides, to leave only a knife edge, and hardening. Drill hole in steel plate and cut with the screw described by turning with reverse or left-handed motion. Left-handed screws can be made very successfully with this plate.

SCREW DRIVER. A well made and light screw driver is an important tool to the watchmaker. The point should be well polished and of a width nearly equal to the diameter of the screw head. One of



Fig. 278.

the best forms on the market is the Waltham, shown in Fig. 278. It has four different sizes of blades which are readily adjusted to position.

Screw drivers, are sometimes made in sets, the various width of blades being readily detected on the bench, as the color of the handle of each width is different.

SCREW EXTRACTOR. The Bullock Screw Extractor, shown in Fig. 279, is a simple yet very valuable accessory to the watchmaker, who finds he has a plate in which a screw has been broken off. To use this tool, first fasten it in your vice, then bring one end of broken or

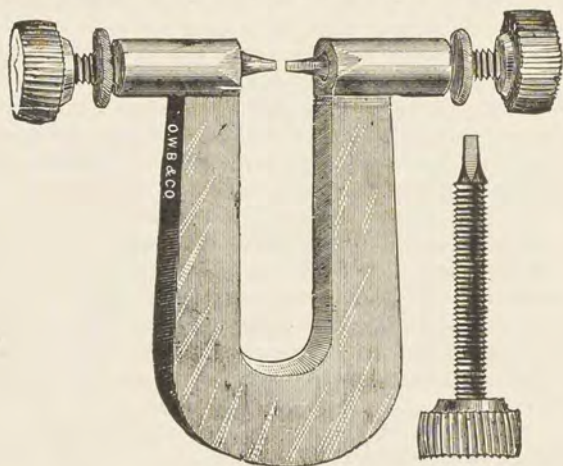

Fig. 279.

rusted-in screw against screw center and the broken screw head against screw driver; turn the washers so as to hold the broken screw firmly in place; turn the plate gently, and the broken screw will follow the screw driver point out of the plate. It may be necessary in some instances to turn the screw driver point against the broken head with a good deal of force in order to start the screw. A little benzine or kerosene applied to the screw will help to loosen it.

SCREW HEAD SINK CUTTER. This tool is not kept by material dealers, although a tool which somewhat resembles it, known as the countersinker, is. The countersinker does not have the central pivot for centering up by. We sometimes have American watches brought to us with the end-stone (cap jewel), broken, and a new one must be put in. The jewel, being set in brass, is held by two screws on opposite sides, the screw heads being let in, or sunk even with the surface, half of the screw head projecting over on the end-stone. The end-stones furnished by the watch companies are not sunk for these screw heads, but are round and of the proper diameter. These cutters will cut

away from the jewel the space to be occupied by the screw head in a very few moments, and as perfectly as you like. All the American companies do not use the same diameter of screw head in the cock and potence, consequently you will be compelled to make a separate tool for the Waltham, Elgin, Hampden, Illinois, and other makes of watches, where the sizes are different. With a set of six of these cutters you can fit any American watch. They are easily made, and will repay you for the trouble.

Cut off a piece of wire of the required diameter, about one inch long, and place it in a chuck that fits it snugly, and turn one end to a center about forty degrees. Now reverse the wire in the chuck, and be sure it



Fig. 280.

is true; select a drill that will pass through the screw hole in the cock or potence freely, and proceed to drill a hole in the center of the end of the wire, about one-sixteenth of an inch deep. Remove from the lathe, and with a sharp file and graver, proceed to cut a series of teeth as equal and even as possible. Use a good strong glass while working, and be sure you have every tooth sharp and perfect, as upon this depends the quick and nice work you expect from the tool. When this is well done, proceed to temper fairly hard, and polish up the outside to make it look workmanlike. Now select a piece of steel pivot wire, of a size that will almost fit in the hole drilled in the end of the tool, and polish down to the proper size to drive in the hole tightly. Allow this wire to project about one-sixteenth of an inch, taper the point and polish. The tool being completed, you are ready for work.

Select an end-stone of a diameter to fit tightly in the cock or potence, as may be required; place the hole jewel in place, and then the end-stone pressed down tightly against the hole jewel. Place your cutter in a split chuck that fits true; select a small or medium sized drill rest and place in the tail-stock spindle. Hold the cock or potence, with the jewels in place, against the drill rest, level, and proceeding to run the lathe at a fair speed, slowly feed the cock or potence to the cutter, the projecting pivot in the end of the cutter passing through the screw hole, and acting as a guide to keep the cutter in the center of the hole. Caution must be exercised, or you will cut the recess for the screw heads too deep, as these little cutters are very deceiving, and cut much faster than you would suppose. In fitting an end-stone, select one that is more than flush when the jewel hole and end-stone are in the proper position, and after sinking the screw head as described, turn off on the lathe almost flush or level. Make a small dot on one side of the end-stone, as a mark or guide in replacing it. Remove the end-stone and proceed to polish the top of the setting on a plate glass polisher.

SCREW PLATE. A plate of hard steel in which are threaded holes of various sizes, for making screw threads.

SCREW TAP. A tool for producing screw threads in holes.

SECONDS HAND REMOVER AND HOLDER. The minuteness of the second hand makes it very difficult to manipulate. The little tool shown in Fig. 281 will be found very useful in handling these hands. To use it, raise the spring with the thumb, and push the



Fig. 281.

tool along the dial astride the arbor; then let go the spring and raise the tool. The spring will hold the second hand firmly until replaced. For broaching, hold the tool, spring side down, firmly on bench or vice.

SECONDS HAND SETTING. This improvement in watches is very useful, as it prevents a number of accidents or errors in the regulation. The attempt to open the glass-bezel of the watch to turn the second hand with a pocket knife or other instrument to the right position, to make it correspond with the minute hand, should be avoided, as the second hand may be shifted or loosened on the pivot, or the ends of the hand may be bent so as to catch the other hands, which causes frequently the stopping of the watch; or instead of the front, the back of the watch is opened and with a penknife or pin, the balance is stopped, and it or hairspring may be easily bent, or even a pivot, jewel or end stone broken. It is at any rate not good to touch a fine balance with any instrument whatever, to scratch the same, or even to stop the same, for the purpose of having the second hand in the proper position, because the most careful operator may accidentally drop something into the watch, causing either stoppage or troubles of irregularities in the running or time keeping.

In the corresponding figures the invention is illustrated as applied to pendant-set watches of well known construction. The second hand is attached to a small wheel *1*, placed upon a thin steel cannon, that fits firmly to the seconds-wheel pivot, as shown in Fig. 282. The stem-winding wheels are placed under the yoke, and the crown-wheel, intermediate winding-wheel, and the setting-wheel, as usual. The wheels *6*, *5*, *4* and *3* are flat, pivoted to the watch-plate, and are used to connect the small wheel *2* with the said stem-winding wheels. This wheel *2* is applied to a rocking-lever and held out of gear with the seconds-set wheel *1*, by the short arm of the lever resting against the circular edge of the yoke. The said lever is pivoted upon wheel *5*, to the watch-plate,

and has a weighted arm *W*, which forms a weight to the lever, so that the same can change its position, by gravity, when the watch is held with its stem downward. This is done when the seconds are required to be set. The weighted part then holds the rocking-lever against the edge of the yoke, which is provided with a notch or stop *s*. In the downward position, the stem is pulled outwardly, and the yoke is moved by the usual spring and mechanism, to the position shown in Fig. 283, to an *intermediate* position between the setting and winding positions, or plainly said, the winding-wheel *I* just passes freely the barrel-arbor wheel *B* and the setting-wheel is not yet engaged to the dial-wheel *D*. The movement of the yoke being stopped by its notch or stop *s* coming in contact with the rocking-lever, which, by the gravity of its weighted part bearing against the edge of the yoke, *drops into* its notch *s*, thereby stopping the yoke on its way toward the setting position. When the lever is caught by the notch *s* the same is turned on its pivot, so that its wheel *z*

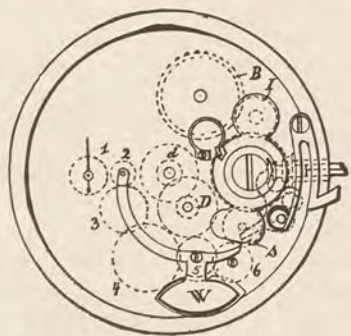

Fig. 282.

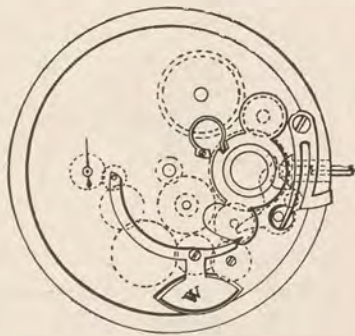

Fig. 283.

is brought in gear with the seconds setting-wheel *1*, and by turning the stem now, the second hand can be turned forward or backward to any second of the dial. By doing this the watch can be held in any desired position, either horizontal or with its stem up, as it must be understood, that the lever is now held firmly into the notch of the yoke by the pressure or the yoke spring, which the weight of the lever cannot overcome, and therefore a sure connection is established between the second setting-wheel and the stem-arbor of the watch. When the seconds hand has been adjusted, an *immediate* disconnection of the wheel *z* from the seconds wheel *1* is established by pressing the stem arbor inwardly, whereby the yoke is shifted or swung to the winding position, and the notch *s* away from the rocking lever, which is turned upon the edge of the yoke to its normal position as shown in Fig. 282. If the minute hand has to be set solely, the stem is pulled outwardly as usual, whereby the watch is held in any position except that with its stem downward, (which

is only done in case the seconds hand has to be set, to produce the dropping of the rocking-lever into the notch *s*), and stops the yoke in its motion before reaching the setting position. In holding the watch in the usual position, the weighted rocking-lever always passes *over* the notch and is held on the circular edge of the notch in this position, but the yoke can freely swing to its setting position, that is, its setting-wheel is brought fully in engagement with the dial-wheel for setting the minute hand. The second hand can either be operated before or after the setting of the minute hand, at will.

The Figs. 282 and 283 represent an Elgin 16 size open face pendant-set watch. Fig. 284 represents a Waltham 18 size pendant-set watch. The weight *W* is shown herein separated from the working-lever, that controls the wheel 2. The stop *s* on the yoke is formed aside from the notch arranged into the circular edge of the yoke and the rocking-lever is always pressed against the same by a suitable spring. The wheel *z* is

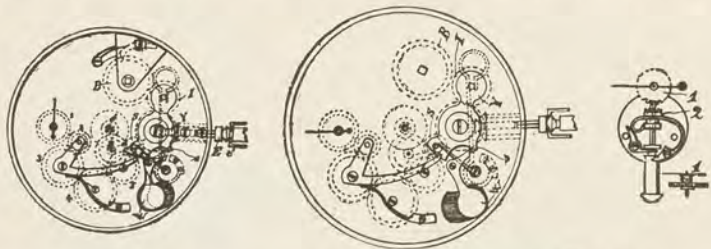

Fig. 284.

Fig. 285.

Fig. 286.

held out of gear with the seconds-setting wheel *z* as long as the said notch is not engaged by the rocking-lever, this being only the case, by first holding the watch with its stem *E* down, so that the weighted part *W* can engage the stop *s*, which is brought toward and against the same, when the stem is pulled outwardly. In this position the notch of the yoke is exactly moved in line with the end of the rocking lever and engaged thereby, which is turned with its wheel *z* out of connection with the seconds-set wheel *z*, as shown in Fig. 284. In pressing the stem inwardly, the yoke is again brought back to the winding position as usual and the notch away from said rocking-lever, which is thereby turned with its wheel *z* out of connection with the wheel *z*. When the minutes are to be set, hold the watch in any position except with the stem downward, and pull the stem outwardly. The motion of the yoke is then produced by its spring to its fullest turn, that is, the setting-wheel *S* is brought in connection with the dial-wheel *D*, as usual. It will thus be seen, that as long as the rocking-wheel is held against the circular edge of the yoke, the wheel *z* is held out of gear of wheel *z*, and can only connect with the same when the yoke is shipped around sufficiently and stopped by the weight, and this can be done only by pulling

the stem out so that the notch can come in line with the end of the rocking-lever, which moves into the same and receives thereby the motion to set its wheel z into gear with wheel x .

Fig. 286 is a seconds-setting attachment which can be placed on key or stem winding watches of a peculiar construction. x is the seconds-hand wheel and the wheel z , which is placed on a small longitudinally movable stem, is shiftable in or out of connection with the said wheel x by the outward or inward motion of said stem. The invention was patented March 20, 1888, by Fred Terstegen, of Elizabeth, N. J.

SECTOR. A mathematical instrument, consisting of two rulers connected at one end by a joint; mostly used for measuring wheels and pinions.

SHELLAC. A resinous substance used extensively by watchmakers and jewelers for holding work. Shellac is a corruption of Shell-lac. *Lac* is the original name of the resinous product which is exuded from an insect which feeds upon the banyan tree. In its natural state it incrusts small twigs and is known as *stick-lac*. It is then broken from the wood and boiled in alkaline water and the product, from its shape, is called *seed-lac*. It is then melted and reduced to thin flakes, known in commerce as *shell-lac* or *shellac*.

SHERWOOD, N. B. A clever mechanic, mathematician and inventor. He was born in New York state in 1823. In 1856 he entered the employ of Mr. Howard in the Waltham factory, and there his inventive



N. B. Sherwood.

genius was brought into full play in originating new tools and machines to do the work formerly done by hand. He not only conceived new ideas, but being an excellent draftsman, he placed them on paper and then entering the machine shop he put these machines together. Under his charge the jewelery department of the factory made a complete revolution over the old methods, and new methods and systems of doing work were introduced and the product doubled. Many of the machines and tools used to-day in watch factories were invented and first built by him. Among his many inventions were the counter-sinker or screw-head tool, for jewel screws; the end-shake tools, the opener, and the truing-up tools. In 1864 he interested capitalists and organized the Newark Watch Company. He died in October, 1872.

SIDEREAL CLOCK. A clock adjusted to measure sidereal time. It usually numbers the hours from 0 to 24. See *Time*.

SIDEREAL DAY. The interval of time between two successive transits over the same meridian of the vernal equinox, or first point of Aries. It is the true period of the earth's rotation. See *Time*

SILVER. A soft, white, precious metal, very malleable and ductile and capable of taking a high polish. For Silver Plating, see *Electro-Plating*

Separating Silver. The silver-holding alloy or metal is dissolved in the least possible quantity of crude nitric acid. The solution is mixed with a strong excess of ammonia and filtered into a high cylinder, provided with a stopper. A bright strip of copper, long enough to project beyond the liquid, is next introduced, which quickly causes separation of pure metallic silver. The reduction is completed in a short time, and the reduced silver washed first with some ammoniacal solution and then with distilled water. The more ammoniacal and concentrated the solution, the more rapid the reduction. The strip of copper should not be too thin, as it is considerably attacked, and any little particles which might separate from a thin sheet would contaminate the silver. The operation is so simple that it seems preferable to all others for such operations as the preparation of nitrate of silver from old coins, etc. Any accompanying gold remains behind during the treatment of the metal or alloy with nitric acid. Chloride of silver, produced by the impurities in the nitric acid, is taken up by the ammoniacal solution, like the copper, and is also reduced to the metallic state; and whatever other metal is not left behind, oxidized by the nitric acid, is separated as hydrate, (lead, bismuth), on treating with ammonia. Any arseniate which may have passed into the ammoniacal solution, is not decomposed by the copper.

To Distinguish Genuine Silver. File or scrape the surface of the articles to be tested, rub the exposed portion on a touchstone and apply a test water consisting of 32 parts of distilled water and 16 parts of chromic acid. Rinse the stone in water and if the article is genuine silver a red spot will be left upon the stone, but if it is an imitation the mark will be unaffected. The finer the quality of the silver the more intense will be the red spot.

Silver Assay with Testing Tube. Place in the tube enough of the pulverized mineral to fill one inch of space, and on this pour nitric acid to occupy two inches more, and hold the mixture over the flame until the acid boils. The acid will dissolve whatever silver may be present, and must be passed through filtering paper to remove extraneous matter, and returned to the tube. Next add a few drops of water saturated with salt; any silver or lead that may be present will be precipitated in a

cloudy form to the bottom. Drain off the acid, place the precipitate in the sunlight, and in a few minutes, if it contain silver, it will turn to a purple color, and may be again liquified by the addition of spirits of ammonia. The testing tube is formed of thin glass, about five inches long, and less than one inch diameter; bottom and sides of equal thickness. Where the tube is lacking, a cup may be used instead.

Silver Assay by Smelting. If no lead is present, mix 600 grs. of the pulverized ore with 300 grs. carbonate of soda, 600 grs. of litharge, and 12 grains charcoal in a crucible; add a slight coal of borax over all, put on the furnace, melt, take off, give it a few taps to settle the metal, let it cool, and remove the button.

To Clean Silver Plate. The tarnish can be removed by dipping the article from one to fifteen minutes in a pickle of the following composition: Rain water, 2 gallons, and cyanide of potash $\frac{1}{2}$ pound; dissolve together, and fill into a stone jug or jar, and close tightly. The article after having been immersed, must be taken out and thoroughly rinsed in several waters, then dried with fine, clean sawdust. Tarnished jewelry can be speedily restored by this process; but be careful to thoroughly remove the alkali, otherwise it will corrode the goods.

Cleaning Silverware. Hyposulphate of soda is the simplest and most effective cleansing material for silverware; it operates quickly and is cheap. A rag or brush moistened with the saturated solution of the salt cleanses, strongly oxidized silver surfaces within a few seconds, without the use of cleaning powder.

Cleaning Silver Tarnished in Soldering. Expose to a uniform heat, allow it to cool, and then boil in strong alum water; or, immerse for a considerable length of time in a liquid made of one-half ounce of cyanide of potash to one pint of rain water, and then brush off with prepared chalk.

Cleaning Silver Filigree. Anneal your work over a Bunsen flame or with a blowpipe, then let grow cold (and this is the secret of success), and then put in a pickle of sulphuric acid and water, not more than five drops to one ounce of water, and let your work remain in it for one hour. If not to satisfaction, repeat the process.

To Frost Silver. To produce a frosted surface upon polished silver use cyanide of potassium with a brush; the silver should not be handled during the process, but held between pieces of boxwood or lancewood. The proportion should be, 1 ounce of cyanide of potassium in 1 pint of water.

To Frost Silver. Silver goods may be frosted and whitened by preparing a pickle of sulphuric acid 1 dram, water 4 ounces; heat it and immerse the silver articles until frosted as desired; then wash off clean, and dry with a soft linen cloth, or in fine clean sawdust. For whitening only, a small quantity of acid may be employed.

To Frost Silver. The article has to be carefully annealed either in a charcoal fire, or with a blowpipe before a gas flame, which will oxidize the alloy on the surface, and also destroy all dirt and greasy substances adhering to it, and then boiled in a copper pan containing a solution of dilute sulphuric acid—of 1 part of acid to about 30 parts of water. The article is then placed in a vessel of clean water, and scratch-brushed, or scoured with fine sand; after which the annealing or boiling-out is repeated which will in most cases be sufficient to produce the desired result. If a very delicate dead surface such as watch dials, etc., is required, the article is, before the second annealing, covered with a pasty solution of potash and water, and immediately after the annealing, plunged in clean water, and then boiled out in either sulphuric acid solution, or a solution of 1 part cream tartar and 2 parts common salt to about 30 parts of water. If the article is of a low quality of silver, it is well to add some silver solution, such as is used for silvering, to the second boiling out solution. If the article is very inferior silver, the finishing will have to be given by immersing it in contact with a strip of zinc in a silver solution.

SINGLE-BEAT ESCAPEMENT. An escapement in which each tooth of the escape wheel delivers but one impulse, the entire space between one tooth and the next passing each time, as in the chronometer and duplex.

SKIVE. A circular disc of soft iron charged with diamond upon its edge and is used for slicing the harder stones.

SLIDE REST. The slide rest is a tool holder to be used on a lathe; it is so universally used by all watchmakers that a full description is superfluous. Fig. 288 is a Waltham, and is a fair example of a modern slide rest for watchmakers' use. The tool holder varies with the different makers, but the rests proper are all made on the same general principle: that of two sliding beds working at right angles to one another and carrying a tool holder, which is capable of being raised or lowered, or set at any desired angle.

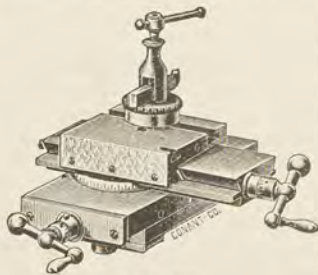



Fig. 288.

SNAIL. A cam resembling a snail in form, used in the striking attachment to clocks.

SNAILING. The ornamentation of the surface of metals by means of circles or bars, sometimes erroneously called damaskeening

SNAP. A small catch, or fastening, as in a bracelet. The fastening of one piece of metal to another by springing of the edges, as in the bezel of a watch case.

SNARL. To emboss or raise figures upon metal work by driving the metal up from the back with a die or snarling iron, as in metal vases.

SNARLING IRON. An  shaped steel tool which is used in snarling, or embossing metal vases, etc. One end of the snarling iron is placed in the vise, and the shank being struck with a hammer, the repercussion of the other end drives out the metal. The snarling iron is only used on vases, pitchers, and like hollow ware.

SOLDERING. The act of joining two metallic surfaces by means of a more fusible metal, or metallic cement. Solders are commonly divided into two groups, known as hard solders and soft solders; the former fuse only at a red heat, while the latter fuse at low degrees of heat. In hard soldering, it is frequently necessary to bind the parts to be soldered together with what is known as binding wire, which is made of soft iron, or the repair clamps shown in Fig. 238, or soldering forceps shown in Fig. 257. The blow pipe is used most extensively for soldering, although small soldering irons are used on the larger kinds of work. It is of the utmost importance that the meeting edges of all articles to be soldered be scraped, or chemically cleaned. While soldering, articles are usually placed upon a piece of charcoal, though asbestos, or pumice stone is better for the purpose. Charcoal emits gases from the coal while under the blowpipe, which enter into the alloy of gold or silver and render it brittle. To prove this, reduce a small piece of 10k gold to a liquid form on a piece of charcoal, and treat a piece similarly on a piece of asbestos or pumice stone, and after allowing each to cool, subject both to a heavy pressure, and note the difference in their malleability and ductility.

Hard Solders. Under this name very different alloys are used, depending upon the metals to be united. The following table shows the composition of various hard solders, which have stood a practical test for various purposes:

	Parts Brass	Parts Zinc.	Parts Tin.
Refractory - - -	4.00	1.00	
Readily Fusible, - - -	5.00	4.00	
Half White, - - -	12.00	5.00	1.00
White, - - -	40.00	2.00	8.00
Very Ductile, - - -	78.25	17.25	

Gold Solders. Gold solders should approach the articles to be soldered in both color and fusibility as nearly as possible. The following gold solders are in general use:

	Parts Gold.	Parts Silver.	Parts Copper.	Parts Zinc.
Hard solder for 750 fine -	9.0	2.0	1.0	
Soft solder for 750 " -	12.0	7.0	3.0	
Solder for 583 " -	3.0	2.0	1.0	
Solder for less than 583 " -	2.0	2.0		
Readily Fusible Solder -	11.94	54.74	28.17	5.01
Solder for yellow Gold -	10.0	5.0		1.0

Silver Solders. The following hard silver solders have been thoroughly tested:

	Parts Fine Silver.	Parts Copper.	Parts Brass	Parts Zinc.
First - - -	4		3	
Second - - -	2		1	
Third - - -	19	1	10	5
Fourth - - -	57	28.6		14.3

Soft Solder. The soft solder most frequently used consists of 2 parts of tin and 1 of lead. The following table gives the composition of various soft solders with their respective melting points:

Number.	Parts Tin	Parts Lead.	Melts at Degrees F.	Number.	Parts Tin	Parts Lead.	Melts at Deg. F.
1 - - -	1	25	558	7 - -	1½	1	334
2 - - -	1	10	541	8 - -	2	1	340
3 - - -	1	5	511	9 - -	3	1	356
4 - - -	1	3	482	10 - -	4	1	365
5 - - -	1	2	441	11 - -	5	1	378
6 - - -	1	1	37	12 - -	6	1	380

Aluminium Solder. The following alloys are recommended for the purpose: 1. Melt twenty parts of aluminium in a suitable crucible, and when in fusion add 80 parts zinc. When the mixture is melted, cover the surface with tallow, and maintain in quiet fusion for some time, stirring occasionally with an iron rod; then pour into moulds. 2. Take 15 parts of aluminum and 85 parts zinc, or 12 parts of the former and 88 parts of the latter, or 8 parts of the former and 92 parts of the latter; prepare all of them as specified for No. 1. The flux recommended consists of three parts balsam copaiba, one of Venetian turpentine, and a few drops of lemon juice. The soldering iron is dipped into this mixture.

Soldering Fluxes. For hard solder use borax rubbed to a paste with water on a slate. For soft soldering dissolve a small piece of zinc in pure hydrochloric acid until effervescence ceases. Take out the undissolved zinc after 24 hours, filter the solution, add $\frac{1}{2}$ its volume of spirits of sal-ammoniac and dilute with rain water. This fluid is non-corrosive.

Soft Solder for Smooth Surfaces. Where two smooth surfaces are to be soldered one upon the other, you may make an excellent job by moistening them with the fluid, and then, having placed a sheet of tin foil between them, hold them pressed firmly together over your lamp until the foil melts. If the surface is fitted nicely, a joint may be made in this way so close as to be almost imperceptible. The bright looking lead, which comes as a lining for tea boxes, is better than tin foil,

To Dissolve Soft Solder. Nitric acid may be used safely for gold not lower than 12k, and is very effective. The following is suitable for all grades of gold and silver: Green copperas, 2 oz.; saltpeter, 1 oz., reduced to a powder and boiled in 10 oz. of water. It will become crystallized on cooling. Dissolve these crystals by the addition of 8 parts of spirits of salts to each part of crystals, using an earthenware vessel. Add 4 parts of boiling water, keep the mixture hot, and immerse the article to be operated upon, and the solder will be entirely removed without injuring the work.

Soldering Stone Set Rings. There are various ways for doing this, but the following will be found as good as any: Take tissue paper and tear it into strips about three inches wide, twist them into ropes, and then make them very wet and wrap the stone with them, passing around the stone and through the ring until the center of the ring is a little more than half full of paper, always winding very close, and then fasten upon charcoal, allowing the stone to project over the edge of the charcoal, and solder very quickly. The paper will prevent oxidation upon the part of the ring it covers, as well as protecting the stone.

Soldering Forceps.

229

SOLDERING FORCEPS. By the use of this ingenious device, any article to be repaired can be adjusted in any desired position in a much shorter time, and with more accuracy, than by the ordinary process of binding with wire to a piece of charcoal. The Crane Patent Soldering Forceps are so constructed that any two pieces can be as readily brought together as can be done with the fingers, no matter at what angle or position you may desire them. Each part works independent of the

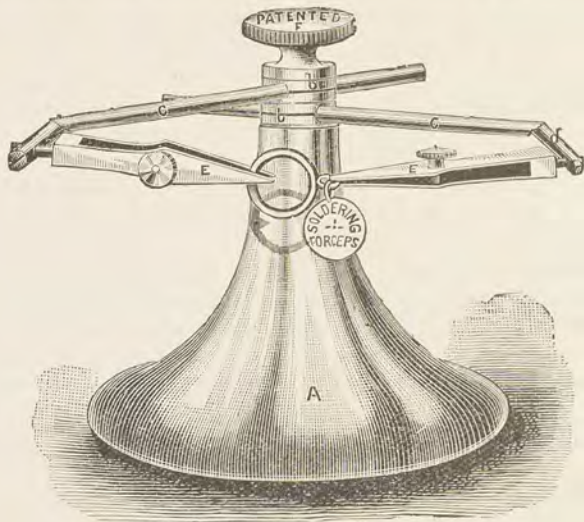

Fig. 289.

other, and the whole is held securely in place by means of a nut, as shown in Fig. 289, at *F*, and both hands being free, charcoal can be held behind the article, thereby concentrating the heat, the same as when held directly upon it. In soft soldering it can be used to great advantage.

The forceps *EE*, revolve in parts *dd*, which are fastened to arms *CC*, by means of a hinge joint. The arms *CC* run through the collars *bb*, so that they can be lengthened or shortened, and the forceps raised or lowered as desired. The collars *bb* turn independently of each other on base *A*, and being split, the whole is held firmly in position by nut *F*. See also *Tweezers*.

SOLDERING PADS. Figs. 290 to 292 illustrate Melotte's non-conducting soldering pads, which are reversible, and adapted to contain a small crucible and ingot mould on one side, a removable rim, shown in Fig. 290; a detachable handle, and various spring clamps as shown. Fig.

292 illustrates Melotte's new gas blow-pipe, which is used with these pads. This blow-pipe is simple and convenient, and, as will be seen by consulting the illustration, it consists of a blow-pipe of the ordinary form having a gas pipe inserted in the lower half, and a threaded hood or sleeve at the lower end, which changes the shape of the flame by screwing in or out, so as to vary the

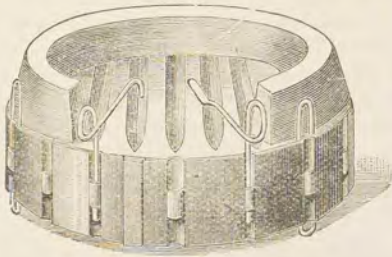

Fig. 290.

influence of the current of air upon the flame. A ring adapted to slip over the finger while working, is soldered to the middle joint of the pipe, and the quantity of gas is controlled by the stop-cock and

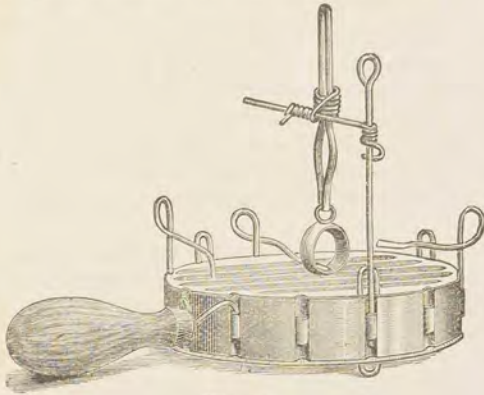

Fig. 291.

spring lever shown in the cut, the gas being supplied to the pipe by a rubber tube connecting it to the nearest gas jet in the usual way. Thus having the shape of the flame under control, and



Fig. 292.

the quantity variable at will, the workman is in position to accomplish the desired end speedily and effectually.

To use to the best advantage, set the jamb-nut so that with the valve lever in its normal position, the flame at the end of the pipe will just keep alight. The blow-pipe can then be laid down temporarily, and again used without the trouble of turning off the gas or relighting.

When used as a mouth blow-pipe, the most convenient way to hold it is with the third finger through the ring. For bellows work it is better to pass the ring over the index finger. The ring also serves, with the valve-lever, as a rest to hold the flame-nozzle away from the table when the blow-pipe is laid down temporarily.

To produce an oxy-hydrogen flame, connect the air-pipe with a cylinder of nitrous oxide, opening the cylinder-valve carefully, so as to permit the escape of only sufficient nitrous oxide to produce, with the illuminating gas, a very small flame. Regulate the illuminating gas flow with

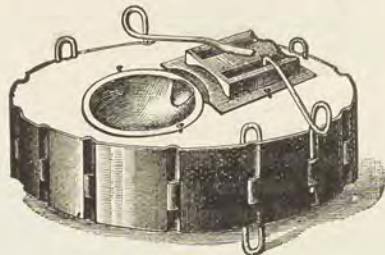

Fig. 293.

the thumb-screw, or with the finger on the lever of the blow-pipe valve.

For soldering, use the grooved face of the pad, with or without the removable rim (shown in Fig. 290), according to the work. The wire staples answer the double purpose of holding the removable rim in place and raising the pad from the table, with air-space underneath.

The spring-clamps are useful in holding the parts to be soldered, the loops in the metal band around the pad permitting them to be placed in any desired position.

For melting, use the reverse side of the pad, with the depression for melting-cup. Fig. 293 shows the melting-cup and ingot-mould in place. The shield is a flat piece of metal, with a lip at one end. The small melting-cups should always be used, as flux adheres to the pad, and pulls off particles of the fiber. The cup is held in place by two pins, inserted in the pad on either side, with the head bent over the edge of the cup. Place the shield upon the pad, with the lip in the depression underneath the edge of the cup; and fasten securely by placing pins through the notches in the edges. Then place the ingot-mold upon the shield, with the mouth of the proper matrix opposite the lip in the cup. To insure a smooth ingot, the ingot-mold should be slightly warmed, and oiled or

waxed. After the metal is melted, tilt the pad gradually, carrying the metal toward the mold, and pour quickly. The handle of the pad can be attached at any point.

SPECIFIC GRAVITIES. The following table shows the specific gravities of numerous metals employed in the arts, together with their melting points, malleability, ductility, and tenacity.

Metals.	Specific Gravity.	Melting Points.		Order of Malleability.	Order of Ductility.	Tenacity.*
		Fahrenheit	Centig'de			
Platinum....	21.40 to 21.50	Infusible except by the Oxyhydrogen blow-pipe.		6	3	274
Gold.....	19.25 to 19.50	2016°	1102°	1	1	150½
Mercury....	13.56 to 13.59					
Lead.....	11.40 to 11.45	612°	322°	7	9	27½
Silver.....	10.47 to 10.50	1873°	1023°	2	2	187
Bismuth....	9.82 to 9.90	497°	258°			
Copper.....	8.89 to 8.96	1994°	1090°	3	5	302
Nickel.....	8.40 to 8.60	2706°	1482°	10	10	
Iron.....	7.77 to 7.80	2786°	1530°	9	4	549
Tin.....	7.25 to 7.30	442°	228°	5	8	34½
Zinc.....	6.80 to 7.20	773°	412°	8	7	109½
Antimony...	6.75 to 6.80	A little below red heat Volatiliz s below fusing.				
Arsenic.....	5.70 to 5.90					
Aluminium..	2.56 to 2.60	1300°	705°	4	6	300

SPECTACLE TOOL. Nearly every watchmaker knows what a troublesome thing it is to repair spectacle frames. When soldered, the solder will run through and fill the groove for the glass, and it is no easy matter to cut the solder out of the groove with a graver. The graver will slip, scratch and mar the frames in spite of the greatest care. This spectacle tool will cut out the groove in gold, silver, steel or any other spectacle frames in a moment's time, smoothly and perfectly. This tool is not for sale by material dealers, but can be made by any ingenious watchmaker. Take a piece of Stubs' polished steel wire, say number 40 by steel wire gauge, and one and a fourth inches long. Insert the wire in a chuck in your lathe, allowing the end to project about one-fourth inch; proceed to turn both ends to a center, as shown in Fig. 294. Select two female centers of the proper size; place one in the taper chuck of your lathe and the other in the tail stock spindle; fasten a dog on the piece of wire, and proceed to turn the wire even and straight throughout its entire length. Remove from the lathe, select a

*Number of lbs. sustained by 0.787 of a line in diameter in wires of the various metals.

split chuck that will fit snugly, place the wire in the chuck, allowing about three-eighths of an inch to project; remove the T rest of your lathe, and insert in its stead a filing fixture. By the aid of the index on the lathe pulley and the filing fixtures, proceed to square the end of the wire, (about one-fourth inch), of a size to fit in an American ratchet wheel. Now select two ratchets of the same thickness and size and place them on the square cut on the wire. Proceed to round up the balance of the square not occupied by the ratchets, and with the screw plate cut a nice full thread on the end up to the square. Now cut off a small piece of steel wire, the same in diameter as the body of the tool, true it in your lathe chuck and drill a hole in the center about one-eighth inch deep. With a screw tap, of the proper size to fit the screw on the end of



Fig. 294.

the shaft, which is now a small spindle, tap a good thread in the hole. This short piece is intended for a nut. With a graver cut it off to the desired length, replace the two ratchets and screw on the nut; replace the spindle in your lathe and turn up the nut round and true. While in the lathe, square half the length of the nut on two sides only. This is intended for a grab or hold for your pliers in removing the nut from the spindle. You can vary the width of the cut by using two or three ratchets as is desired. In order to make the groove rounding, the shape of the spectacle glass, hold an oil stone to the edge of the ratchets while revolving, which will round them very slightly. American ratchet wheels make good cutters and any width of groove can be cut. When the teeth get dull they can easily be sharpened or new wheels can be substituted. With this tool you can cut the solder out of spectacle frames in a few minutes. It will also prove useful in enlarging spectacle frames, in fitting new lenses.

SPLIT SECONDS. A variety of double chronograph in which there are two center-seconds hands.

SPRUNG OVER. A watch in which the hairspring is attached to the staff above the balance.

STAFF. An axis or arbor.

STAKE. An anvil. To fasten by means of a stake.

STAKING TOOL. A tool needed by every watchmaker, consisting of a shifting table or stake, around which holes of various sizes are arranged in a circle, so that any desired hole may be brought under a suitable punch moving in a vertical holder. Usually twenty-four tempered steel punches and four stumps are provided, which will be found sufficient to cover all the operations in the ordinary run of watch repairs,

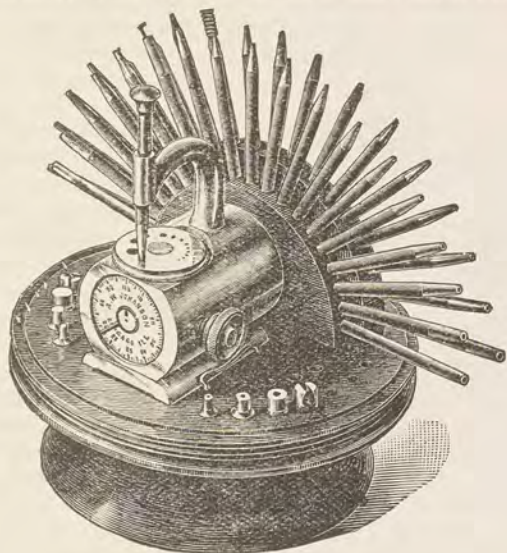

Fig. 295.

and the ingenious workman can from time to time add to these by making punches in his spare moments, if he finds from experience that he is in need of punches of a different shape. Fig. 295 illustrates the Johanson combination staking tool on the front of which a hairspring stud indicator is arranged.

STAKING TOOL AND ANVIL. Smith's patent staking tool, anvil and screw holder, shown in Fig. 296, will be found a very handy



Fig. 296.

tool for removing and putting on rollers, for putting hairspring collet on balance staff, or for riveting in bushings. The plain staking block, or anvil, is usually made of a solid piece of polished steel, in the form of a cube, or circular as in Fig. 297. The example shown has a reversible center hub which makes it valuable for putting on hands, etc.

STAR WHEEL. The wheel of the stop work which is pivoted to the barrel and also known as the Maltese cross.

STEADY PINS. Pins used to secure two pieces of metal in relative positions, as a bridge and plate.

STEEL. Iron, when combined with a small portion of carbon. The varieties of steel are very great. Puddled steel is made from pig iron by a modification of the puddling process. Cast steel is made from wrought

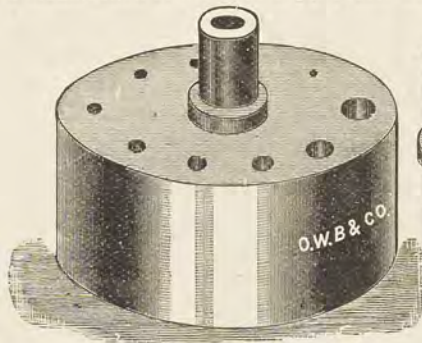

Fig. 297.

iron or blister steel by mixing it with powdered charcoal, after which it is melted in a crucible, cast into ingots and rolled or hammered into plates or bars. Blister steel is made from wrought iron by interlaying it with charcoal and keeping it at a high temperature for a number of days.

Bessemer steel is made from the liquid cast iron as it comes from the smelting furnace by blowing air into it, thus burning out a portion of the carbon.

To Anneal Steel. There are nearly as many methods of annealing as there are workmen. The commonest methods are as follows: Heat to a dull red, bury in warm iron filings or ashes, and allowing the article to cool very gradually. Another method is to heat the piece as slowly as possible, and when at a low red heat put it between two pieces of dry board and screw them tightly in a vise. The steel burns its way into the wood, and on coming together around it they form a practically airtight charcoal bed. Brantt gives the following method, which he says will make steel so soft that it can be worked like copper: Pulverize beef bones, mix them with equal parts of loam and calves' hair and stir the mixture into a thick paste with water. Apply a coat of this to the steel and place it in a crucible, cover this with another, fasten the two together with wire and close the joint hermetically with clay. Then put the crucible in the fire and heat slowly. When taken from the fire let it cool by placing it in ashes. On opening the crucible the steel will be found so soft that it can be engraved like copper.

To Anneal Small Steel Pieces. Place the articles from which you desire to draw the temper into a common iron clock key. Fill around

it with brass or iron filings, and then plug up the open end with a steel iron or brass plug, made to fit closely. Take the handle of the key with your pliers and hold its pipe into the blaze of a lamp till red hot, then let it cool gradually. When sufficiently cold to handle, remove the plug, and you will find the article with its temper fully drawn, but in all other respects just as it was before. The reason for having the article thus plugged up while passing it through the heating and cooling process is, that springing always results from the action of changeable currents of atmosphere. The temper may be drawn from cylinders, staffs, pinions, or any other delicate pieces by this mode with perfect safety.

Hardening and Tempering Steel. The process of heating steel to a red heat and immediately chilling it is the same among all workmen, but the agents employed for chilling are very numerous. The receipts here given are from various sources, and the reader must adopt the one which he finds on trial, is the best adapted to his wants.

In all cases the object should be heated to a red heat before plunging. If an object to be hardened is long and slender, it should invariably be inserted in the hardening compound end-wise, otherwise it will come out warped and distorted. The same rule applies to thin or flat objects. A preparation is used in hardening, consisting of one teaspoonful of wheat flour, two of salt and four of water. The steel to be hardened, is to be heated sufficiently, dipped into the mixture, to be coated therewith, then raised to a red glow, and dropped into cold soft water. Another method is to raise the object to the required heat and then drop it into a mixture of ten parts of mutton suet, two parts of sal-ammoniac, five parts resin and thirty-five parts olive oil. Oil, tallow, beeswax and resin are also employed for hardening. If an intense brittle hardness is desirable, drop the object into mercury or nitric acid. In heating very small or thin objects, they should be placed between two thin pieces of charcoal and the whole brought to the required heat. In this way you avoid uneven heating and hence it will be uniformly tempered. When it is desirable to harden an article without discoloring its surface, it should be placed in a metal tube or bowl of a clay pipe, and surrounded with charcoal that has been previously heated to expel all moisture, and when raised to the proper heat the whole should be immersed in the hardening liquid.

Mat for Steel. The article to be treated must first be ground flat and free from scratches in the usual manner. When this is accomplished take oil stone powder, mix it with oil and then add a little blue-stone powder. Grinding is performed best upon a composition of iron plate, or a file of the same material; glass is not as well suited for the purpose. A large quantity of grinding powder and oil should be used. Very hard articles take a good mat grinding with difficulty, and whenever possible it is advisable to anneal them blue.

Do not press too hard in grinding; the small grains of oilstone should assume a rolling motion, whereby they will to a certain extent, wear hollows with their sharp edges in the surface of the steel, all of which together will impart the handsome, mat appearance. If too much pressure is brought to bear, and the grinding material is too dry, it will cake on the steel and produce the disagreeable scratched surface so often seen.

The quantity of bluestone necessary for grinding can be scraped off from a large piece, after which the scrapings must be thoroughly crushed. The oilstone powder must not be too fine and should be of uniform grain. The proportions are 1 part of bluestone to 4 of oilstone powder.

Tempering. Before tempering, the surface of the object must be thoroughly cleaned and freed from grease by the application of oilstone dust, emery, or some like scouring agent. The object should not be handled with the fingers after cleaning, or it will be difficult to obtain the requisite tint. The following table by Stodart will be valuable to the student:

1	430° F	Very Pale Straw Yellow.....	220° C
2	450° F	A Shade Darker Yellow.....	235° C
3	470° F	Darker Straw Yellow.....	245° C
4	490° F	Still Darker Straw Yellow.....	255° C
5	500° F	Brown Yellow.....	260° C
6	520° F	Yellow tinged with Purple.....	270° C
7	530° F	Light Purple.....	275° C
8	550° F	Dark Purple.....	290° C
9	570° F	Dark Blue.....	300° C
10	590° F	Paler Blue.....	310° C
11	610° F	Still Paler Blue.....	320° C
12	630° F	Light Bluish Green.....	335° C

After letting an object down to the required color it should be allowed to cool gradually, and no artificial means used to hasten the cooling. A piece of steel may be let down to the same color several times without in any way injuring it or altering its properties. Tempering of small articles is performed satisfactorily by means of the bluing pan. (See Fig. 38). Small articles are also tempered by placing them in a vessel, say a large spoon, covering them with oil and heating them to the requisite degree. This is a favored method of tempering balance staffs and similar articles. The temper is usually judged by the color of the smoke; Saunier gives the following rule: When smoke is first seen to rise, the temper is dark yellow (or No. 2). Smoke more abundant and darker (No. 5). Black smoke still thicker (No. 7). Oil takes fire when lighted paper is presented to it at No. 9. After this the oil takes fire of itself and continues to burn. If the whole of the oil is allowed to burn away No. 12 is reached.

The Color of Steel at Various Degrees of Temperature. The following table gives the temperature corresponding to the various colors of steel when heated.

1	980° F	Incipient Red.....	525° C
2	1290° F	Dull Red.....	700° C
3	1470° F	Incipient Cherry Red.....	800° C
4	1650° F	Cherry Red.....	900° C
5	1830° F	Clear Cherry Red.....	1000° C
6	2010° F	Deep Orange.....	1100° C
7	2190° F	Clear Orange.....	1200° C
8	2370° F	White.....	1300° C
9	2550° F	Bright White.....	1400° C

Combined Hardening and Tempering. M. Caron, with a view to combining the two operations of hardening and tempering, suggested that the temperature of the water used for hardening, be heated to a predetermined degree. Thus the requisite temper may be given to gunlock springs by heating the water in which they are hardened to 55° C. or 130° F.

To Work Hard Steel. If steel is rather hard under the hammer when heated to the proper cherry red, it may be covered with salt and hammered to about the shape desired. More softness can then be obtained, if required to give further finish to the shape, by sprinkling it with a mixture of salt, blue vitriol, sal-ammoniac, saltpeter and alum; make cherry red again, sprinkle with this mixture, and hammer into shape. This process may be repeated until entirely finished. When ready, the steel is hardened in a solution of the same mixture. This method is recommended by prominent workers.

To Remove Rust. Kerosene oil (refined petroleum), or benzine are the best agents for the removal of rust, where the object is not pitted. When pitted, however, it can only be removed by mechanical means, such as scouring with emery powder and oil.

To Prevent Rust. Rub the article with a mixture of lime and oil, or a mixture of equal parts of carbolic acid and olive oil, or with plumbago.

Anti-rust Varnish for Steel. The rusting of steel and iron tools and instruments is very perfectly prevented by coating them with a varnish made by dissolving 1 part of white wax in 15 parts benzine, and applying with a brush. The very thin layer of wax forms a perfect covering for bright tools and when desired is very easily removed.

Browning or Bronzing for Steel. Aqua fortis and sweet spirits niter, each half an ounce, sulphate of copper 2 ounces, water 30 ounces, tincture muriate of iron 1 ounce, Mix.

To Protect Steel from Rust. Immerse in a solution of carbonate of potash for a few minutes and it will not rust for years, not even when exposed to damp atmosphere.

To Temper Small Steel Articles. The tempering of small drills, for drilling holes in arbors, staffs, etc., which we find are very hard and difficult to perforate, may be effected in the following manner : After having filed the drill to its proper size (being careful not to flatten the cutting face), you then warm it moderately, not allowing it to become red, and run it into borax. The drill is thus coated over with a crust of borax and secluded from the air. Now it may be hardened by heating it only cherry red ; after this it is inserted into a piece of borax, or what is better still, plunged into mercury ; taking care not to breathe the mercury fumes. Drills prepared in this way, without being brittle, will become exceedingly hard and the watchmaker will be enabled to drill articles which could not otherwise be perforated with a drill. Do not use broken broaches to make your drills, as the steel in them is often burned, rendering the metal unfit for use in small tools. In order to make the quality of your drill a certainty, always take a new piece of round steel for the purpose.

To Harden Steel in Petroleum. According to B. Morgossy, the articles to be hardened are first heated in a charcoal fire, and, after thoroughly rubbing with ordinary washing soap, heated to a cherry red. In this condition they are plunged into petroleum ; ignition of the petroleum need not be feared if no flame is near at hand. Articles hardened by this method show no crack, do not warp if plunged endwise, and after hardening remain nearly white, so they can be blued without further preparation.

Hardening Liquids. If water is used for hardening, 32° F. will be found about right for the sized articles hardened by watchmakers, and if the article is very small; ice may be added to the water. A solution composed of 1 quart of water, 1¼ lbs. sal-ammoniac, 10 oz. of refined borax, 1¼ ozs. of red wine, is used extensively for fine cutlery. A mixture of 1 lb. of resin, 3 ozs of lard, ½ lb. train oil and ½ oz. assafoetida is said to be excellent for fine steel work.

Directions for Plunging when Hardening. Thin articles, as steel plates, or articles of small diameter; such as drills, should always be plunged into the hardening compound, end or edge foremost to avoid

warping. If an article is thicker on one side than the other, as a knife blade, the thick side should enter the compound first. Heat the article only as far as you wish to harden it and immerse it as far as it has been made red hot.

Tempering by Electricity. Watch springs have of late years been successfully tempered with the aid of electricity. The steel ribbon is passed through a bath of oil and an electric current of sufficient strength to keep it at the proper heat is passed through the ribbon. The heating is thus effected without contact with the atmosphere and the spring is not liable to blister as in ordinary methods. The temper is drawn in the same manner and the heat can be controlled to a nicety and is uniform throughout. The spring is then finished by means of rolls.

Glass Polisher for Steel. French plate glass, ground on one side, makes a good polisher for flat work. A piece four inches square, nicely finished on the edge, is about the right size.

Tempering Magnets. M. Ducoetet uses the following process for tempering and magnetizing steel to be used as magnets. Two soft iron pole pieces are placed in the bottom of a water tight vessel and are connected with the poles of a powerful electro-magnet. The vessel is partially filled with water, and oil is poured into the vessel, which floats upon the surface of the water. The red hot bar is then passed through the liquids and comes in contact with the magnets. This softens the steel without depriving it of its power of being magnetized.

To Engrave Name on Steel Tools. Coat the tool or article, if made of iron or steel, with a thin layer of wax, draw the name, initials or design through the wax, exposing the metal, and place the tool in a mixture of 6 parts by weight of water and 1 part of sulphuric acid. In a few hours remove, and if etched sufficiently, wash in clean water and dissolve the wax by heat.

STOGDEN, MATTHEW. Inventor of the half-quarter repeating mechanism most used in English watches. He died in abject poverty, about 1770, at an advanced age.

STOP WORK. The mechanism which prevents the overwinding of a timepiece.

STRAIGHT LINE LEVER. That form of a lever escapement in which the escape wheel arbor, pallet and balance staff are all planted in a straight line, as in Fig. 266.

STUD. A small piece of metal which is slotted to receive the outer coil of the hair spring. Any short rod or roller projecting from a part of the machine is termed a stud. To set with projecting jewels or pieces of metal, as watch cases are sometimes ornamented.

SULLY, HENRY. Born in 1680 and died in 1728. A celebrated watchmaker and the author of a work on horology. He was an Englishman by birth, though he resided most of the time in France, where he died.

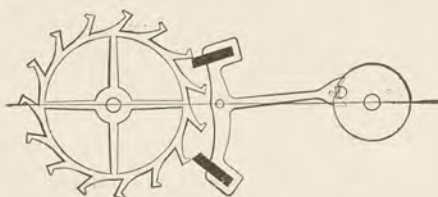

Fig. 298.

SUNK SECONDS. A dial in which the second bit, as it is called, is cut out and sunk below the surface of the dial itself, thus gaining space for the hour and minute hands.

SURPRISE PIECE. The four-armed piece secured to the quarter snail which is free to move within certain limits, and prevents the rack from reaching the snail. See *Repairing Repeating Watches*.

SWEEP SECONDS. A movement in which a long seconds hand moves from the center of the dial instead of at the bottom, as in chronographs and split seconds watches.

TABLE. The roller of a lever escapement that carries the impulse pin. The upper flat surface of a diamond, or other precious stone, the sides of which are cut in angles.

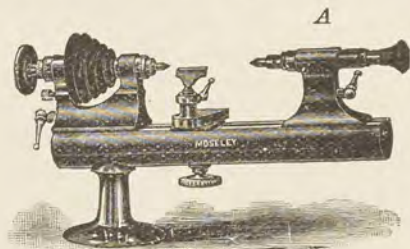

Fig. 299.

TAIL STOCK. The sliding block or support in a lathe that carries the tailscrew and back-center, as shown in *A*, Fig. 299.

Half Open Tailstock. The half open tailstock shown in Fig. 300, is cut away so that the spindles can be laid in, instead of being

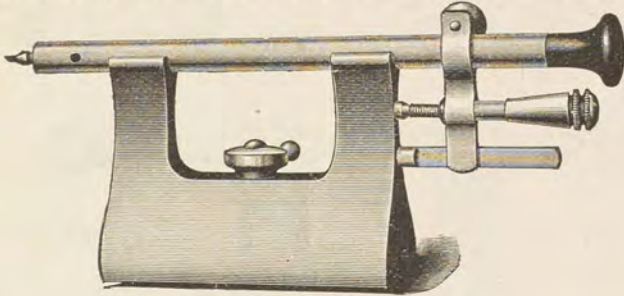

Fig. 300.

passed through the holes. This fixture will be found exceedingly convenient when several spindles are to be used for drilling, counter-boring and chamfering.

Screw Tailstock. This attachment is very convenient for heavy drilling, the spindle being moved by a screw with hand wheel attached, as shown in Fig. 301.

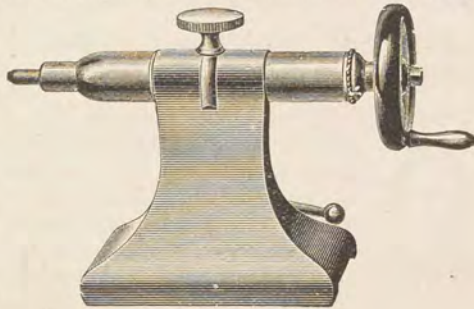

Fig. 301.

Traverse Spindle Tailstock. This attachment, shown in Fig. 302, will be found very convenient for straight drilling. Where the watchmaker has a great deal of drilling to do, he will find this attachment invaluable.

TAVAN, ANTOINE. A celebrated French watchmaker who resided the better part of his life in Geneva. Born at Aost, France, in 1749 and died in Geneva in 1836.

TAVERNIER, LOUIS. A celebrated Parisian watchmaker who lived about 1800. He studied the cylinder escapement with great care and with considerable success.

TESTING NEEDLES. Small strips of steel with gold points, usually running from 4k. to 20k. inclusive, and used in conjunction with a touchstone for determining the quality of gold. The gold to

be tested is first rubbed upon the touchstone, and the needle which most closely approximates to it in quality, in the judgment of the operator, is also rubbed upon the stone. The two marks are then treated with nitric acid and the difference in color indicates the difference in quality of the two marks. See *Touchstone*.

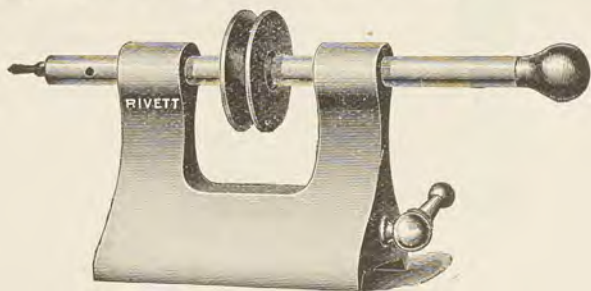

Fig. 302.

THIRD WHEEL. The wheel in the train of a watch which lies between the center and fourth wheels.

THIOUT, M. Watchmaker to the Duke of Orleans. In 1741 he published a work called "Traite d'Horlogerie," in two volumes.

THOMAS, SETH. One of the early American manufacturers of clocks. In 1810 Eli Terry sold out his clock factory to Seth Thomas and Silas Hoadley, two of his leading workmen, and this factory was the leading one for many years. The present corporation, known as the Seth Thomas Clock Company, is the direct successor of this humble beginning. March 31, 1853, the Seth Thomas Clock Company was organized with a capital of \$75,000. Seth Thomas died January 20, 1859, being 73 years of age.



Seth Thomas.

THREE-QUARTER PLATE. A watch in which enough of the upper plate is cut away to allow of the balance vibrating on a level with the plate.

TIME. The measure of duration. A particular period of duration. Time is measured by the interval between two successive transits of a celestial body over the same meridian; if measured by the sun, it is called solar time, or if by a star; sidereal time.

Absolute Time. Time irrespective of local standards or epochs; time reckoned for all places from some one common epoch; as all spectators see a lunar eclipse at the same instant of absolute time,

Apparent Time. Time as reckoned by the sun; the instant of the transit of the sun's center over the meridian constituting 12 o'clock.

Astronomical Time. Mean solar time, reckoned by counting the hours continuously up to twenty-four from one noon up to the next.

Civil Time. The reckoning of time for the common purposes of life. The division of time into years, months, days, hours and seconds.

Sidereal Time. Time regulated by the transit, over the meridian of a place of the first point of Aries, or the vernal equinox, and chiefly used in astronomical observations.

The sidereal day is 3 m., 56 s. shorter than the mean solar day. The pendulum of a clock, to show sidereal time, must be a trifle shorter than that of one used to show mean time, both clocks having the same train. On or about the 15th of April the two clocks would agree, but from that time on there would be a divergence of 3 m., 56 s. per day. In the absence of a transit instrument and a table giving the right ascension of particular stars, Britten advises the selection of a window having a southern aspect, from which a chimney, or a stee-

Days	Stars Gain			Days	Stars Gain		
	Hours	Minutes	Seconds		Hours	Minutes	Seconds
1	0	3	56	11	0	43	15
2	0	7	52	12	0	57	11
3	0	11	48	13	0	51	7
4	0	15	44	14	0	55	3
5	0	19	39	15	0	58	18
6	0	23	35	16	1	2	54
7	0	27	31	17	1	6	50
8	0	31	27	18	1	10	46
9	0	35	23	19	1	14	42
10	0	39	19	20	1	18	38

ple or any other fixed point, may be seen. To the side of the window attach a thin plate of brass having a small hole in it, in such a manner that by looking through the hole toward the edge of the elevated object, some of the fixed stars may be seen; the progress of one of these being watched, the instant it vanishes behind the fixed point a signal is made to a person observing the clock, who then notes the exact time at which the star disappears, and on the following night the same star will vanish behind the same object 3 m., 56 s. sooner. If a clock mark 10 h. when the observation is made, when the star vanishes the following night it should indicate 3 m., 56 s. less than 10 h. If several cloudy nights have rendered it impossible to

compare the clock with the star, it will then be necessary to multiply 3 m., 56 s. by the number of days that have elapsed since the observation, and the product deducted from the hour the clock then indicates gives the time the clock should show. The same star can only be observed during a few weeks, for, as it gains nearly a half hour a week, it will, in a short time, come to the meridian in broad daylight and become invisible; to continue the observation, another star must be selected. In making the observation, care must be taken that a planet is not observed instead of a star; Mars, Jupiter and Saturn are those most likely to occasion this error, more especially Saturn, which, from being the most distant of the three, resembles a star of the first magnitude. The planets may, however, be easily distinguished, for being comparatively near the earth, they appear larger than the stars; their light is also steady because reflected, while the fixed stars scintillate and have a twinkling light. A sure means of distinguishing between them, is to watch a star attentively for a few nights; if it change its place with regard to the other stars, it is a planet. See *Transit Instrument*.

Solar Time. Sun time. Time marked by the diurnal revolution of the earth with regard to the sun. A mean solar day is the average length of all the solar days in the year. The difference between true and mean time is called the equation of time. There are only four days in the year when the apparent and mean time are the same, and the equation of time nothing. These are December 24th, April 15th, June 15th, and August 31st. Between December 24th and April 15th, and between June 15th and August 31st, the apparent is always before the mean time, whilst in the remaining interval it is later.

TIMING. See *Adjustment*.

TIMING SCREWS. Quarter screws of a compensation balance.

TOMPION, THOMAS. Born in 1638 and died in 1713. He was buried in Westminster Abbey.



Thos. Tompion. **TOUCHSTONE.** A piece of black basaltic rock, obtained chiefly from Silesia and used for testing the quality of gold. The piece of gold, or metal to be tested is drawn upon the surface of the touchstone, and the streak left is treated with nitric acid. Nitric acid eats away the streak if it is brass or any similar alloy, while if gold only the alloy in the gold is attacked. Testing needles of known alloy are then rubbed on the surface of the touchstone, and treated with the acid, and a comparison made. See *Testing Needles*.

TOURBILLION. This arrangement of the train and escapement is the invention of A. L. Breguet and consists of a light steel framework in which the escapement of a watch was mounted upon the fourth pinion, taking the place of the fourth wheel. By this arrangement the escapement revolved, thus eliminating the position errors to a great extent. The arrangement of Breguet has been simplified by Bonnicksen and is known as the Karrousel watch.

TRAIN. The train of a watch or clock is the wheels and pinions through which the motive power is transmitted to the escapement. The names of the various parts in a going barrel are the barrel, which has been given the name of center wheel because it occupies a central position in the plate of the movement. Following the center wheel is the third, fourth and fifth wheels respectively, the latter one being known as the escape wheel. The pinions are known by the same name as the respective wheels which are mounted upon them. It is desirable to have the size of the train as large as possible, preserving a systematical proportion between the first and last of the train, that is one wheel should be no larger than the one immediately preceding it, the general rule being to have each succeeding wheel smaller. The center wheel makes a revolution in one hour, and it is from this that the number of vibrations are reckoned. The number of vibrations per hour may be found by multiplying together the number of teeth in the centre, third and fourth wheels and multiplying this product by twice the number of teeth in the escape wheel and dividing this last product by the product of the number of leaves in the third, fourth and escape pinions. In watches showing seconds the proportion between the center and fourth wheels must be as one to sixty, because it is this pinion that carries the seconds hand. This formula for determining the vibrations applies equally well to any of the escapements, whether watch or clock. The mainspring should develop enough turns to run the timepiece at least thirty hours. The train of a watch may be tested by sharpening a piece of pegwood and with it pressing on the end of the pinion pivot into which the wheel depths, when its condition may be judged. All other things being equal, the train having the largest wheels and pinions with the greatest number of teeth and leaves, will transmit the motive power most uniformly and with the least friction. In the finest trains, the wheels should be poised, or at least very near it, this item being the more important as we approach the escapement.

TRANSIT INSTRUMENT. A telescope mounted at right angles to a horizontal axis. Used in connection with a clock or watch for obtaining the time of transit of a heavenly body over the meridian of a place. To watchmakers who make any pretense of a knowledge

of their business, nothing can be more desirable or useful. A vague impression exists among them, that the transit instrument, used for this purpose, is so closely allied to the scientific, as to be serviceable only in the hands of the professional astronomer. This fact, taken in connection with the high cost of these instruments hitherto, fully accounts for the reason of their unfrequent employment.

These two causes, preventing the more general use of the transit, no longer remain, whatever may have been their force in the past. By an improvement in the mode of mounting, a ready means is furnished for setting up and placing the instrument in the meridian. Furnished with each transit are full printed instructions, describing each part in detail, the method of setting up, and taking observations, the whole of which is so plain and simple that every purchaser is surprised and gratified to find what was supposed to be difficult so easy to perform.

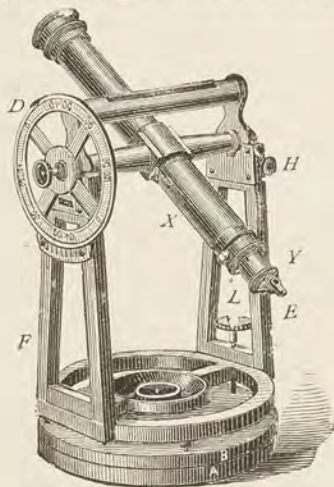

Fig. 305.

The stand on which the instrument rests, consists of two circular plates of metal, the lower of which, A, is to be screwed to a foundation of wood or stone; screw holes being provided for that purpose. The upper plate, B, turns upon the lower by means of a pivot, and the two are clamped together by a clamping screw. In the upper surface of the plate B, are sockets for receiving the three points on which the frame of the instrument rests.

When the clamping screw is loosened, the entire instrument may be easily rotated horizontally upon the lower plate A, and when the clamping screw is tightened, the whole is rigidly held in position.

The telescope is ten inches long and fitted with an axis, the two pivots of which rest in the top of the frame F. At X is a sliding tube, which adjusts the focus of the object glass. The telescope is furnished

with a diagonal eye-piece, E, which is made movable in a sliding tube at Y, to adjust the focus of the eye piece. Small screens of colored glass are provided to protect the eye from the effects of the rays of the sun. On the axis of the telescope is attached a declination circle, D, used only for facilitating the finding of stars, when on or near the meridian, but not used in taking observations of the sun. Upon the pivots of the telescope is placed a riding level, for the purpose of leveling the axis of the telescope by means of the leveling screw, L.

One of the pivots of the axis rests in a block made moveable by the horizontal adjusting screw.

The instrument must command an unobstructed view of the north star, and the sun at noon. Usually the coping of a brick or stone building, easy of access, will be found the most convenient, but in the absence of this, a brick or stone pier, from sixteen to twenty-four inches square, built from four feet below to four feet above the ground, would be excellent, or a post six inches or more in thickness, firmly set in the ground would answer a very good purpose. A costly foundation offers no practical advantage and its greater expense need not be incurred. At the place chosen secure very firmly, a piece of plank two or three inches thick, of any suitable size, which should be well leveled, and thoroughly painted, top and bottom, to protect it against the action of the weather, and upon this plank screw the lower bed plate of the instrument. The instrument may be covered with a tight box, constructed to turn water and exclude dust, or, if removed after each observation, a tight cover should be made for the rotating stand, which must be left in its position.

The instrument is placed in position, or on the meridian line, by setting the center line in the field of view of the telescope, on the north star, at the time of night the said star is on the meridian, which time is calculated for any desired place and furnished in tabular form with each transit. Perfectly correct time for this operation, which is very simple, is not essential, but only as near as is in common use.

The instrument must now remain unmoved until a range mark has been obtained as follows :

On the day succeeding the setting of the center line on the north star, turn the telescope to the south, and notice some small object of a permanent character, which the center line bisects. This object is called the range, and may be at any distance from twenty feet to half a mile, but two or three hundred yards will be found best. If no convenient object can be selected, a range may be made by painting a small round spot on a permanent surface, at a point where the center line will bisect it. Before taking an observation the center line must always be set exactly on the range with the screw H, in order to secure an accurate adjustment in the meridian. The range may be either north or south, but the latter is more convenient.

The purpose of the range mark is to furnish a means of keeping the instrument in the meridian without being obliged to re-set the center line on the north star.

METHOD OF TAKING AN OBSERVATION OF THE SUN.

Set the center line on the range, if off the same, and carefully level the axis, a few minutes before the sun comes in the field of view, which will be about four minutes before reaching the center line. As the telescope is an inverting one, the sun will appear to come in from the right hand side and pass across the field of view.

When the *first*, or advancing edge of the sun intersects the center line, the time must be noted by the watch, as in example. When the sun has passed entirely across the center line, which takes about two and a quarter minutes, note the time when the *last* edge intersects the center line, as in the same example.

Time of contact of <i>first</i> edge of sun with vertical line..	11	43	14.5
“ “ “ <i>last</i> “ “ “ “ “ “ ..	11	45	30.
Divide by 2.....	2)	23	28 44.5
Add correction (from table supplied with instrument).	11	44	22.2
		16	12.5
Subtract 12 hours.....	11	0	34.7
	12		
Watch fast 34 seconds, 7 tenths.....		0	34.7

After adding the above correction, the difference between the result and 12 hours will be the amount the watch was fast or slow ; fast if more than 12 hours, and slow if less.

TRAVERSE SPINDLE GRINDER. This tool will be found very useful for grinding cutters, lathe centers, pump centers, reamers, counter sinks, squaring up barrel arbors after hardening, or any hardened steel tool. In the hand of an ingenious workman, it will be found exceedingly useful, as by its aid a great variety of work can be performed that cannot be accomplished without it. Fig. 306 is the Moseley pattern, and is designed to attach to the slide rest.

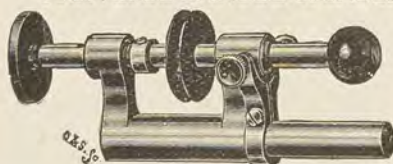

Fig. 306.

TURNS. A small dead center lathe used but little in this country.

TWEEZERS. The watchmaker will do well to purchase tweezers that are made of non-magnetic material, as they are no more expensive

than ordinary ones of good make. Steel tweezers often become magnetized and by their use you convey the magnetism to the delicate parts of a movement. There are several makes of non-magnetic



Fig 307.

tweezers upon the market, all of which possess points of excellence. Soldering tweezers are made similar to Fig. 307, with hawk bill, for holding work while hard or soft soldering. See also *Soldering Forceps*.

TWO PIN ESCAPEMENT. A variety of the lever escapement having one small gold pin in the lever and two in the table, and the unlocking and impulse actions are divided between them.

UNIVERSAL HEAD. The universal head, shown in Fig. 308, has entirely superseded the clumsy universal mandrel in this country. It is more accurate, less clumsy and complicated and will perform the same work. The face plate is $3\frac{1}{2}$ inches in diameter, but by the use of two crescent-shaped slots; it will hold anything in size and shape

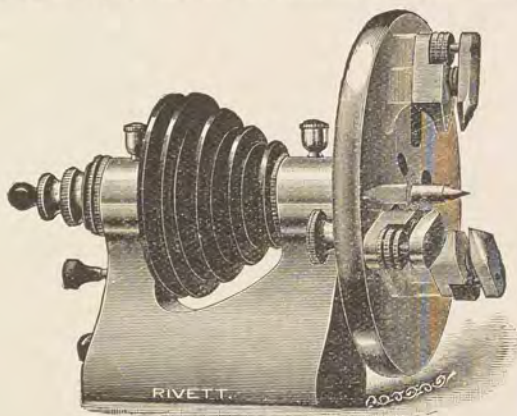

Fig. 308.

of watchwork. The pump centre is operated from the back by the rubber knob and can be used either with or without a spring. The jaws, which will pass the center, are held in position on face plate by springs, and are fastened from the back. Peep holes are provided in these heads in order that the workman may examine the back of the work at all times. In the Moseley head, shown in Fig. 308, these holes are of taper form. Fig 309 shows a universal face plate to be

used on chuck in lathe. It is smaller and less expensive than the universal head and answers very well for some work, but cannot be recommended very highly, as it is not as accurate. The pump center is used to center from the back any object confined in the jaws, but it sometimes becomes necessary to mount the object by means of wax upon a plate and hold the plate in the jaws. In such a case the work must necessarily be centered from the front. This can be done accurately by means of a piece of pegwood, as ordinarily done on the lathe, by placing the point in the center hole and the pegwood resting on the T rest, and observing if the free end of the pegwood remains stationary. See, also, *Centering Tool*.

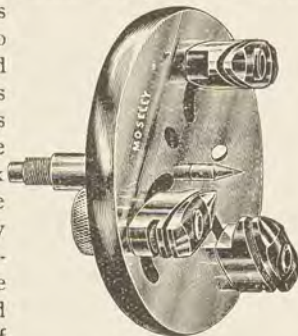

Fig. 309.

UNLOCKING RESISTANCE. The resistance opposed to unlocking by the adhesion between the locking faces of the pallets and the tips or the escape wheel teeth, and in the case of lever pallets by the draw of the locking faces.

VERGE. The piece in a watch or clock which regulates the motion of the escape wheel and allows one tooth to pass at a time. In a watch it acts as a support for the balance wheel. This name is especially applied to the recoil escapement used in the so-called Yankee clock, and shown in Fig. 6.

VERGE ESCAPEMENT. This form of escapement is shown in Fig. 310, which shows a plan of the escape wheel and verge in their

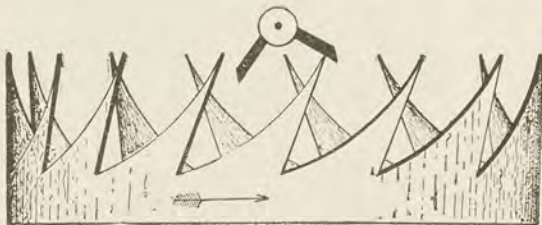

Fig. 310.

relative positions in a watch. The inventor of this form of escapement remains in obscurity, but it appears to have been invented about the

year 1000, and was the sole escapement up to the seventeenth century. The verge has served a very good purpose in its time, but its lack of correct timekeeping led to its disuse as soon as something better appeared. The escape tooth drops direct upon the impulse plane. If the momentum of the balance is sufficient to overcome the power of the mainspring a recoil is the result, but if not the result is a to and fro motion just sufficient to escape. As shown in the drawing, when the tooth in contact with the right hand pal'et leaves it the tooth shown just below will fall upon the left hand pallet and impel the balance in the opposite direction. The opening of the pallets is usually ninety degrees, that is, at right angles to each other. A workman who is acquainted with the other escapements will have but little trouble in repairing the verge. Fig 6 shows the verge clock escapement.

VERGE PIN. The pin upon which the verge of an American clock is supported. This pin is usually mounted in a small movable arm by which the escapement action may be corrected.

VERGE WIRE. The wire by which the power is transmitted to the pendulum wire. In this class of clock the beat may be corrected by slightly bending it.

VERNIER. A short scale made to slide along the divisions of a graduated instrument, as a caliper, for indicating parts of a division. It is so graduated that a certain convenient number of its divisions are just equal to a certain number, either one less or one more, of the divisions of the instrument, so that parts of a division are determined by observing what line on the vernier coincides with a line on the instrument. See *Gauge*.

VERTICAL ESCAPEMENT. An escapement in which the escape wheel is at right angles to the balance staff or pallet axis.

VIENNA LIME. A pure anhydrous lime, obtained from Vienna. It is extensively used for final polishing purposes, particularly in watch factories. The action of Vienna lime is different from most other polishing agents, for the effect is not produced, as in the case of rouge, by simple abrasion, for unless the lime is used while it is slacking, the result will not be satisfactory. The material should, therefore, be kept in air-tight bottles, and only enough for immediate use taken out at one time. Take a small lump from the bottle, slightly moisten with water and break down with any clean tool,

Spread the lime paste on a boxwood slip and apply to the article to be polished, using quick strokes.

VULLIAMY, BENJAMIN LEWIS. He was born in London, in 1780, was grandson of Justin Vulliamy, a native of Switzerland, who emigrated to London and became acquainted with Benj. Gray, of Pall Mall, married his daughter and succeeded to his business. Benj. Gray was clockmaker to the Crown in the reign of George II, and the position has been held by the Vulliamy family since his death. Benj. Lewis Vulliamy was an earnest student of horology, and was familiar with all the works of ancient and modern horologists. All of his productions were remarkable for their sterling excellence, but the branch to which he devoted the largest portion of his attention and time was the construction of turret clocks, and upon that subject he wrote several valuable pamphlets. He became a member of the Clock-makers Company in 1809. He served every office in the Court of the Guild, and was five times elected master. He died January 8, 1854.

WATCH. A small time-piece to be carried in the pocket. The word watch is said to be derived from the Saxon *wæccan*, to awaken, which would seem to indicate that the earlier watches were of the alarm type. It is, however, much more probable that the term came originally from the watches of the night, and that portable timepieces were invented to mark them.

Cleaning and Repairing. As the movement is taken down, note should be taken of any needed repairs or alterations, either in the watch or case. See that the movement is tight in the case and that the stem turns easily. Examine movement carefully with eye glass and if a Swiss bridge movement, examine the depths of the wheels, see if minute wheel pinion touches the dial, and if balance pivots have too much side shake. Try the side shake of a Swiss bridge with a pair of fine and light tweezers. See if the guard and banking are correct. In a great many Swiss watches and also English watches, the jewel pin is too small for the fork, and often it does not enter properly. Memorize these little things as you go along, and repair them in this regular order. After examining the escapement, let the mainspring down; after taking the movement out of the case, remove the hands first, with a modern tool made for that purpose, that does not interfere with the dial.

Now remove dial, and notice if it fits right; if the hand arbors come in the center of the holes. Oftentimes this can be corrected by bending the feet with a pair of flat pliers, so the edge of the dial will correspond with the movement and the hand arbors. Sometimes, in American watches, the screws do not reach the dial feet; alter this by turning the shoulders off in lathe, so they will go further in. If the pins (when dial is

pinned on) are too high above the plate, fill them with a little pin and soft solder, and drill or punch new holes in the proper place. When you put a new dial on a Swiss watch, where the feet do not correspond with the holes, cut off the feet of new dial and file or grind the enamel flat around the feet and grind the enamel away with an emery wheel, where the new feet are to go. Now take a piece of copper wire, long enough for both feet, and the proper thickness, put it in lathe and hollow out the ends with a graver, so it will hard-solder flat on an old piece of dial copper about three-sixteenths of an inch round. If too large, put it in the lathe by the foot and turn it off. Now have feet prepared for new dial; take a little dissolved shellac and put it on the bottom of each of the dial feet and put the feet to their places in the movement plate.

Slightly moisten the places on the dial, where the new feet come, with dissolved shellac, and lay dial on these feet and see that second pivot comes properly through the dial, and that the edge of the dial corresponds with the edge of the movement plate. Now in this position let dial and movement lay over night, and in the morning the feet will be hard. Now lift your dial off carefully, turn it upside down, and bend up two brass clamps like a hair pin, but not so long, and clamp these feet on the flat part and lay this dial on a cork or piece of wood, feet up. Now put on your soft solder fluid, and blow a broad flame over it, and after the fluid has boiled you can put on your solder and blow again. Now dip it in a solution of cyanide of potassium, and wash off with soap and water, and brush dipped in clean water after the dirt is removed, Then dip it in alcohol, and dry in box-wood saw dust.

The balance, of course, is removed during this process of fitting the dial. Now examine further and we find our center pivot worn and the hole in the bridge or upper plate too large. We now turn the pivot smooth with a graver, and grind with a pivot polisher, or a hand oil stone file, or pencil made of iron wire. Now clean off with pith, and polish with rouge or crocus. Now take the bridge or upper plate, and with a round face-punch in staking tool, close the hole. Now use a round broach and open the hole to its proper size, so it will fit the pivot correctly. Run this broach through, with the bridge screwed to its place, letting the broach go through the opposite hole at the same time. Now in an English watch, we may need a new bush, as the hole may have been bushed to one side and the center wheel be out of upright; but the question is, how to make the best job, so it will be strong, neat and workman like.

If you are compelled to put in a bush, or upright a hole in the center of a Swiss, English or American watch, first broach out the hole about twice its size and tap it with a fine thread. Now put in a threaded bush to fit snug; now rivet it in the staking tool, center the opposite hole in the universal head, center with a graver point and drill the bush in the lathe with a drill a shade smaller than the pivot. Now broach out in the lathe to suit the pivot and turn the bush off nicely with your slide rest.

After sharpening your cutter on an oilstone, run it over a fine emery stick to remove the burr on the cutting edge. Now, with moderate high speed, you can turn off this bush in good style. Should the endshake be too tight, lay your plate (English or full American), on a movement cup or ring, and with a wooden punch and hammer punch it outward. Treat a mainspring barrel in a similar manner when the end shake of the arbor is too tight, by laying it on a small silk spool, one end of the spool turned conically inward, so the outer edge only will touch the barrel. Strike the arbor with a horn, ivory or wooden mallet.

We oftentimes find American and English center pinions badly worn, so that when they are trued and polished up, there will be no shoulder left for the cannon pinion. When they are so badly worn as that, take a piece of steel, sometimes an old English cannon pinion (this will not have to be drilled), put it in lathe and turn a collar out of it, first preparing center pinion to receive this collar. Have this collar a little higher and a little thicker than the pivot is to be, and to go on loosely. Now soft solder it on to its place, wash clean and dry, and put the center wheel with its pinion back in the lathe and finish off with graver and oil stone, file and rouge, as before mentioned. The collar can be hardened and tempered in first-class style, by cutting a piece of binding wire through it and holding over the lamp and dipping in water or oil. Now you can clean it off by running a pointed peg-wood through it, then run over it with a fine emery stick, then lay on the bluing pan and turn to a dark chestnut color.

Take the mainspring out of the barrel, hold the arbor in the same way and revolve the barrel and you can see if it runs true. Now to true this barrel, either Swiss, English, or American, close the top or bottom hole with a round-faced punch, in a staking tool. In a Swiss, close the bottom, and in an English, the top hole. An American seldom needs this treatment. Now put barrel together and center it in universal head, and with a narrow and short cutter in slide rest open the hole that you closed to fit the arbor. When fitted, take it out and revolve it as before and our barrel will be dead true. Now in our key-winder Swiss, we find the ratchet worn, and it needs a new one. As the arbor and ratchet are one piece, we turn the ratchet about half off, edgewise. Now we turn it flatwise, and file or grind the square a little lower, so it will receive the new ratchet. This new ratchet must have a recess turned in it to fit over the part of the old ratchet. The square hole must fit the square snugly. Now, if this new ratchet is not too hard and the teeth not too fine, it will last better than the original. Now, in English watches, the square is oftentimes badly worn, or too small. In this case, draw the temper of the old square, turn it down by holding it in a step chuck by the fusee, taking off the great, or fusee wheel, and maintaining ratchet. After turning it down and squaring the pivot, cut a left-hand thread in a suitable piece of steel, and also on the old square (which, of course, is turned down

in the step chuck), and fit this piece of steel on the old arbor, down to the pivot shoulder, against the stop cam. Now turn it down with a graver and square up the end in a lathe, and drill a very small hole through near the end of the square upper end. Now take and unscrew the new square and harden and temper it. Hold it over the lamp by a piece of binding wire, and dip in oil when cherry red. Now hold it in a chuck and clean it off with an emery stick. Now turn to a dark brown, screw back on, and grind and polish up. No graver is needed on this job after it is hardened and tempered. The thread need not go all the way down; half way will do, but the new square must go against the shoulder tight up to the lower round part of the square. When all done, put the little pin through, which keeps it from coming off when turned to the right.

On opening a barrel observe the condition of the mainspring, and the inside of the barrel head. Often, in good watches, the inside of the barrel head is not flat, and the mainspring scrapes it. Turn this flat with a step chuck and slide rest, at high speed, and sharpen the cutter as before mentioned. Now examine the mainspring, and see if it is the proper strength and width, and examine the hook, or brace, and stop work, the teeth of the barrel, etc. Now, sometimes in American watches, the barrel touches the balance; alter this by countersinking the lower hole of the arbor in the movement plate and bending the bridge down a little in the center, with a wooden spool and wooden punch, as in endshaking the center hole in American watches and the barrel arbor.

Oftentimes we find the winding pinion too shallow for the bevel wheel. Remedy this by either lowering the pinion deeper into the wheel, or the wheel into the pinion. Oftentimes, in Waltham watches of the old series, the intermediate winding wheel is too deep in the ratchet wheel. This can be corrected by the banking screw, by putting in one with a larger head. Now, very often the intermediate setting wheel is too shallow in the minute wheel. Correct this by stretching the lever where it touches the yoke, and taking off a little of the yoke where it banks for the hand setting. Remember that the yoke should be perfectly steady and firm, in turning the hands either way. The teeth of the minute wheel are often ruined when the cannon pinion is a little tight and the intermediate hand setting and minute wheels are too shallow. Never touch the arbor of the cannon pinion, but see that it is perfectly smooth and round. If the cannon pinion is too high from the plate, turn a little off from the under side. Take pinion off with a pair of brass lined pliers. If the cannon pinion is too loose on the arbor (if a stem-wind), punch it in the same place, with a punch in the staking tool, having a V shaped stump to lay the cannon pinion on, and holding it with a peg-wood, or broach, while punching it. Use a punch a little rounding. A cannon pinion should work smoothly all around. Now, in a Swiss watch with a hollow center pinion, when its arbor is too loose, lay the arbor on a small flat anvil, or steel, or brass block, in front of you, not on vise, and hold a

small square file across it, and tap it with a small hammer, rolling it while you tap it. This raises a nice burr all around it. If a little too tight, take it off with an oil stone slip. This can be done when the watch is clean and running.

Now examine the click, and see that it has a loose endshake and that the point goes freely in and out of the teeth of the wheel. Sometimes the point is too blunt, and in many cases, the click spring is too strong. Click springs should have a very low temper, and a nice slender shape, as the bending they perform is very little. They should not scrape on the plate, nor hold the click down too tight, if made like some Elgin clicks.

Now the end shake of the ratchet or ratchet wheel, should have some attention. You can easily manipulate this, if the ratchet is between the plates. End shake it with the winding arbor. Now we have the stem winding wheels, etc., in proper shape. The minute wheel pinion may rub on the dial. Remedy this by grinding the dial away with an emery wheel, and oftentimes free the hour wheel the same way. If there is too much end shake, put on a spring washer, cut it square and turn the corners up. We can examine the train from the third wheel to the scape wheel; see if the holes are large, and end shake correct. In some cases in Swiss watches, where the third and center wheels are under the same bridge, you can sometimes turn the shoulder of the lower pivot back.

Sometimes we find pivots too loose in their holes, and in some cases a new jewel can be put in to fit the pivot to a better advantage. In this case we must be guided by our practical experience, as in many other instances. True pinion or staff in a split chuck, flatten the old place, that you are to center with, on an oilstone slip, and center with a graver. Nine out of ten Swiss or English, and a few American pinions, can be drilled without annealing. Use oil and a properly made drill. For a bow drill use a rounding point, and in an American lathe an obtuse angle point, to cut only one way. Drill pinion or staff, and if you are compelled to draw the temper, do it in the following way: Use a cap made of copper wire, holding the opposite end of staff or pinion in a pair of brass-lined flat pliers; set copper cap on and blow a sharp blaze on the cap to blue article to be drilled. Remove the color with a peg-wood and rouge; first with rouge and oil, and then with dry rouge. Never leave a pinion or staff discolored. Now, if article cannot be trued in split chuck, cement it in, but you can true five out of every ten in a No. 1 Moseley lathe, without cement. For drilling it is not necessary that the article should run dead true; but it should be dead true, in turning the pivot on and finishing. Now, in pivoting after the hole is drilled and the plug is hammered in, turn your pivot to its proper shape with a graver and almost with the point. Turn pivot down to about three degrees thicker than pivot is to be. Now we have our

pivot finished with a graver. Now use an iron wire, about two millimeters thick and about five inches long, flattened about one inch on one end with a file, filing crosswise, and now and then retouching with a fine file. This is done so the file lines or marks will retain the grinding powder to be used with oil. For a staff pivot, always file the corner off a little, so it will conform to the conical shoulder, and file or grind, holding the oil-stone charged file so the latter and the pivot will traverse at an acute angle. This is done to prevent the pivot from lining. Now, if down to the desired size and shape, use another such tool, made of brass or zinc and charged with rouge and oil, and polish pivot in the same manner that you grind it. At last touch it up with dry rouge and a peg-wood. Diamantine and oil or alcohol can also be used to good advantage before using the rouge.

After all repairs, clean your work in the following manner: Use good benzine or gasoline and cyanide of potassium; a lump as large as a walnut to a pint of water. Keep in a glass or china cup with a cover on it. Clean the lever in benzine only and dry in the sawdust. Have an alcohol cup, with cover, plenty of clean soft water (in cold weather use warm water), and a medium soft brush, like a paint brush, about a half inch thick for the benzine. A long, three or four row brush, to use with good castile soap and water, and three, four or more pieces of brass wire made into loops or strings, by bending an eye on each wire like a fishing hook. The wire can be almost any length, from three to six inches, and from three-tenths to five-tenths mm. thick. This, with about three pints of boxwood sawdust, put through a sieve to get out the coarse particles, and a soft camel's hair brush to use dry on the work after it has been cleaned, completes the outfit for cleaning. Put a wire through the top plate, hang in the benzine, and brush it carefully with the benzine brush, principally the pivot holes. After this has been done, pick up the stem wheels, wheels and small parts, unscrew the safety pinions, and wash and clean with the wheels. Oil the thread sparingly when you put it back. String all of these small parts on a wire. Put the lower plate on with the barrel. Use a very thick wire for the balance (dip it separately), and move it about in the benzine; dry it in sawdust, dip in cyanide solution, in clear water, then in alcohol. Then move it about in the sawdust; this will clean the balance and hair spring and roller. After the plates and wheels have gone through the benzine or gasoline, dip them in the cyanide and wash with brush and water and castile soap. Dip in clean water, then in alcohol and then in sawdust. By this process, every speck of oil will be removed, and the gilding or nickle finish will not be injured, as with old foggy chalk, and a variety of powder. Sometimes the dirt in the pinion is thick and hard, and it must be removed with peg-wood; sometimes it has been oiled with linseed oil and left to dry; this can be boiled off in oil and cleaned as mentioned. To get dirt or hard gum out of the wheel teeth, make a kind of pad with stiff writing

paper, draw the edge of these papers through the teeth; this will clean them nicely. When taking the cleaned parts from the sawdust, hold them with Dennison's watch papers, and brush off with a three or four row soft camel or fine goat hair brush. In setting the watch up, set the stem work up first and oil it properly. Right here, in oiling, is where it requires judgment. For the stem work use a heavier oil than for the train. Use refined clock oil for the stem wheels, as they necessarily require a heavier oil, and it also has less tendency to spread. Use watch oil in oiling the center pivots, and they, being large, should have more oil than the third, fourth and scape wheels, etc. Put the proper amount of oil on the end-stone, or cap jewel, before putting the latter to its place; also the barrel arbor. Oil the pallet faces sparingly before putting the lever to its place. Now if your balance and hair spring are true and in poise, and the pivots have their proper freedom and end shake, and the roller its proper freedom, and everything is all right throughout, your watch will move off all right. To ascertain if exactly in beat, hold a peg-wood against the teeth of the fourth wheel, and move it slightly forward, and observe the motion of the balance. If one pallet throws the balance further than the other, turn the hair spring by the collet slot, so that the lift will be equal on both pallets. When in beat, examine the escapement again; see if the balance clears the stud, cock, center wheel, etc. See if all the screws are tight, and by all means have the hair spring so the second coil will not get into the curb pins. After this the train can be oiled. The barrel pivot next to the ratchet, or ratchet wheel, should be oiled before the ratchet wheel is put on. It is well to oil the balance jewel holes after it has been put in beat, on account of dragging in dust with the pivots if they should be oiled before. After this put on the dial wheels; do not oil the minute wheel posts; see that the hour wheel has its proper end shake. In cheap watches put on a thin washer to steady the hour hand and wheel; put the dial on, and see that the second and hour wheel sockets are in the center of the holes after the dial is properly fastened. If you have any steel hands to bend, it will pay you to bend them with a pair of hot tweezers, as this will prevent breaking them. Now set your second hand with your second pendulum regulator, and regulate pendant up. Meantime you can clean the case with water, ammonia and a soft cotton rag. An old tooth brush can be used in the corners. Stiff joints in front case can be loosened up with benzine. This will take the dirt out, and the joints will work free. Cases should be cleaned, like all other repaired work. Often we find balance hole jewels entirely too thick, so they will take an unreasonably long pivot to reach through them. To remedy this, use an iron point charged with diamond powder, that fits the concave of the jewel, and then polish in the same manner with a finer grade of diamond powder, diamantine and rotten stone. Keep the jewel wet with water in grinding and polishing, and use the highest speed you can produce. Care

must be taken in this operation, as it requires a little experience. Like everything else, you will find a great deal of difference in grinding a garnet or a ruby or sapphire, also in polishing them. Zinc and lead points are used in polishing with diamantine and rotten stone and water. If the above process is understood it can be quickly done. The hole can also be polished, but in some cases it will pay better to put in a new and perfect jewel.

Sizes of Watch Movements. Swiss and French watches are measured by the French ligne (line) which is one-twelfth of an inch of a Paris foot. One line equals .088814 of an English inch, or 2.25583 mm. The movements are spoken of as 14-line, 18-line, 19-line, etc. Mr. Aaron L. Dennison is said to be the inventor of the system employed for the sizing of American watches and he first applied it to the watches made by the American Horologe Company, about 1851. One inch was taken as a basing figure and to this $\frac{5}{30}$ of an inch was added for a "fall" or drop, this being allowed so that the movement could be tipped into its place of seating in a ring or case; then every $\frac{1}{30}$ of an inch formed a size. A 16-size would then be $\frac{1}{2}$ inch + $\frac{5}{30}$ + $\frac{11}{30}$ = $1 \frac{21}{30}$.

WATCH BOW PLIERS. Pliers of a peculiar shape, as shown in Fig. 311, and used for manipulating watch bows.

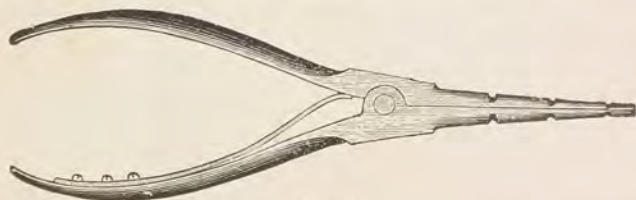

Fig. 311.

WATCH CASE TOOL. The Hopkins' patent watch case tool is designed for the two-fold purpose of easing a case when it opens too hard, and for making one stay shut when it opens too easy. It is illustrated in Fig. 312. The part *D* is intended only for use when the spring catch of a hunting case has worn the case so that it will not stay shut.

For making a back case stay shut when it opens too easily, use the cutting tooth *B*, in the following manner: Rest the beveled edge of the tool from *A* to *C*, down level on the ledge against which the dome or back case closes, as represented in the illustration, taking care to keep the end *A* as well as the tooth *B* down level on the ledge, and inward against the part to be re-undercut, in which position, with the end *D* resting in the hollow of your right hand, back of the little finger, and with your thumb resting on the inner cap to steady your hand,

hold the tool thus quite still, and with your left hand give a circular movement to the watch, crowding the part to be under cut against the tooth *B*, that is, instead of shoving the tool forward to produce the cutting, hold the tool still, and crowd the part of the case to be cut against it as described. By thus renewing the under cut of the catch edge, even a badly worn case may be made to shut and stay shut nicely.



Fig. 312.

For easing the cap or the back case of a watch when it opens too hard, rest the end *A*, of the tool, down on the inside of the dome, with the handle inclining backward at an angle of about 45° , and with one of the sharp edges extending from *A* to *C*, brought to bear against the snap edge that requires to be eased, in such a way that it will give a shaving (not a scraping) cut; carefully shave off the edge, thus, to the extent required. In this way even the most delicate case may be eased without the slightest marring or injury to it. In case of roughness of the snap edge, burnish it carefully with the back of the tool; or rubbing a bit of beeswax around the edge will often be found of service in cases of this kind.

WATCH HAND PLIERS. Fig. 313 shows Horton's combination watch hand pliers for removing watch hands, second, hour and minute. It also takes the place of the 9-hole hand sliding tongs.

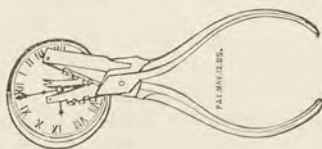

Fig. 313.

WATCH PAPERS. These were circular pieces of paper, silk, velvet, or muslin, placed in the outer cases of the old watches, and were decorated with verses or devices; some of them were very elaborate specimens of scroll work, and had a miniature painted in the center, others merely bore verses. Later this same device was used by repairers as a means of placing a business card in the watch. Many old watches in various collections contain over a dozen of these cards, of repairers in whose hands the watch has been.

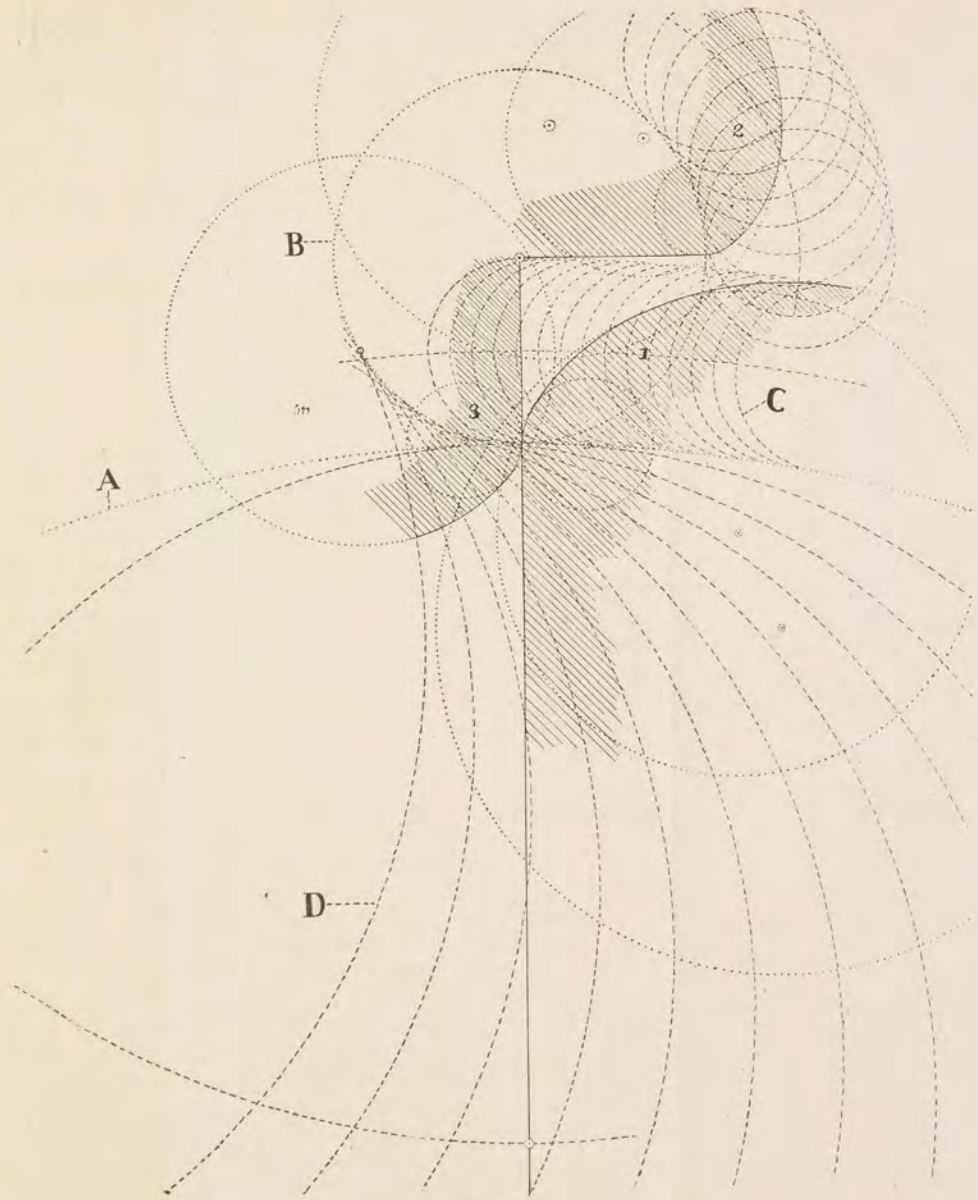

Fig. 314.

WHEELS AND PINIONS. There are few watchmakers who have not some arbitrary rule for determining the size of wheels and pinions by which they can obtain the desired information. There is, however, more to this subject which is shrouded with more or less mystery to the average mechanic and horologist, viz., that after he has selected the diameter of the wheel or pinion, what kind of a tooth he is going to use in such wheel or pinion. There are two general requisites which should be borne in mind and which I am sure every watchmaker does bear in mind: (1) The uniform transmission of power, and (2) the uniform transmission of speed; or, in other words, how to obtain uniform efficiency of the mainspring and how to rotate the pinion at a uniform velocity in proportion to the respective diameters of the wheels and pinions.

Starting with the idea that the average watchmaker knows how to compute the outer diameter of his wheel or pinion, we will take into consideration the watch in which the wheel or pinion is to be inserted. The first thing necessary to determine is, as to whether the watch has a fine or a coarse train, a slow or a quick train. When this conclusion is arrived at, there still remains to consider the thickness of the tooth. Assuming that it is a fine quick train watch, in which the center wheel has 80 teeth and the third pinion 10 teeth. In mechanical engineering it is assumed that 6 to 1 is the greatest ratio that can be maintained between an involute wheel and pinion, and 8 to 1 between an epicyclic wheel and pinion; but in watchmaking we brush these considerations aside and provide for larger differences in angular velocity in unique methods, which the size of this paper will not allow me to consider here.

As is well known in mechanical engineering—of which watchmaking is but a finer degree—when considering the driving train of gears, there are what is termed two kinds of friction, viz., an engaging friction, or friction which occurs when the wheel teeth engage before the line of centers; and a disengaging friction which occurs when the wheel teeth leave or recede from the line of centers. The first friction is the most dangerous in a watch, in that it is a kind of dragging movement, which, like the unwinding of a mainspring, is decidedly irregular, and consequently should be avoided as much as possible. The disengaging friction is what might be termed a pushing friction, and has, so far as can be observed by dynamometer tests, a certain ratio of uniformity, and is not so dangerous in the watch. Therefore, the first thing necessary to consider in designing the train is the thickness of the wheel tooth and pinion; and, of course, the outer diameter of the follower or driven pinion.

The 10-leaf pinion is practically the first pinion with which we can with some degree of assurance have engagement between it, and its wheel teeth, or what is termed the "lead" occur on the line of cen-

ters. Unfortunately, however, in watches this is not always practicable to obtain, in that it would require that the leaf be made very thin. For instance, dividing the 360 degrees—which is the pitch circumference—into ten equal parts, it allows 36 degrees for the circular pitch. To obtain a tooth of theoretical thickness to insure the “lead” beginning on the line of centers, 11 degrees should be taken for the thickness of the leaf and 25 for the space, making the face of the tooth—or that portion above the pitch line—practically a semi-circle; and as this is merely added for safety, it would insure a pinion in which the lead would take place at the line of centers. But these theoretical conditions could not be fulfilled, in that the tooth would be so thin and weak as to be practically unfit for the transmission of power, and also from the fact that the driving wheel would not drive the pinion one-tenth of a circumference, so that a certain amount of drop would take place and a consequent variation in the time-keeping qualities of the watch. To overcome these objections, however, it is safe, to add on a certain amount— $1\frac{1}{2}$ of the circular pitch—taking 13 degrees for the tooth and 23 degrees for the space. Of course some discretion and judgment must be used in these matters, and especially in very small watches even this proportion would be too fine; but the tooth should be made as small as possible consistent with strength, and to prevent drop. This rule, however—or figures which I will give—will be found very satisfactory in watches from 18 to 10 size, inclusive. Below this, circumstances have to be taken into consideration and provided for accordingly.

Summing up briefly, a rule which I found most practicable regarding thickness of tooth and pinions: Where the theoretical conditions cannot (always) be complied with for the pinion leaves— 11° for the tooth and 25° for the space—practical experiment shows that dividing the circular pitch into 30 parts, and taking 11 for the tooth and 19 for the space, makes a good working pinion. To insure absolute freedom, the circular pitch of the wheel should be divided into 9 parts, taking 4 for the tooth and 5 for the space. Having determined the thickness of the tooth, the next thing to determine is what will be the curve of the tooth used in the wheel and pinion. Here, as in other problems, there are a multitude of conditions to be considered, the principal ones being: (1) Transmission of a substantially uniform power; (2) transmission of a practically uniform speed; and (3) the thickness of the tooth of the gear to which the curve is to be applied. Considering the two principal curves which have been advanced after years of experiment, viz., the involute and the cycloid, it has been demonstrated by large indicating levers attached to a dynamometer that the involute drives with the most uniform transmission of power, for the simple reason that it is a curve developed by the transforming of a circle into a straight line. In other words, it is

developed like taking a cord that is wound around a spool and attaching a pencil to the free end, and then unwinding the cord. You will see that the cord becomes a straight line, and the transforming of this cord into a straight line forms a peculiar curve called an "involute." The peculiar feature of this curve is that it is pecu-

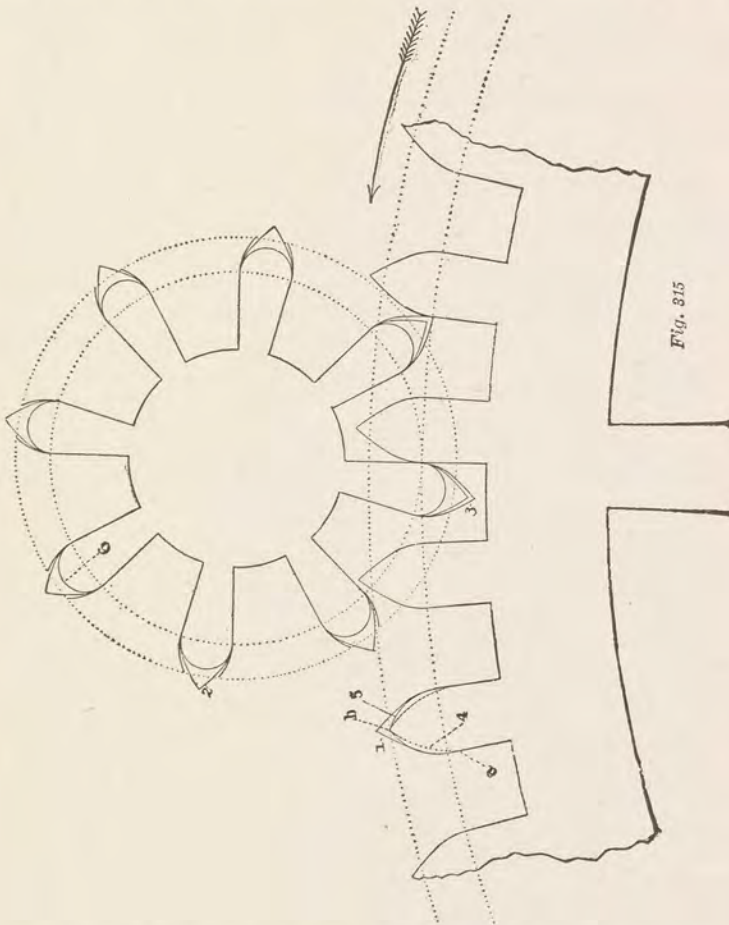

larly adapted to drive the straight flank of a tooth or lever (as such lever is always driven) at right angles to the curve; or, in other words, a tangent. In machine gearing this curve is almost universally used, from the fact that it is very simple to make, and the further fact that

the main object required is the uniform transmission of power. In watchmaking, however, we have a further thing to consider, and that is the pinion or wheel must be driven in such a manner that it should travel through equal degrees of its arc or circumference in equal periods of time. For this purpose eminent engineers have found that the epicycloid or cycloid, as the case may be, is the curve best fitted, in that it is a curve that is developed by either rolling a circle on a straight line—cycloid—and tracing a curve from one point only; or it is a curve—epicycloid—developed by rolling a circle upon another circle and describing a curve with one point of such generating circle.

The accompanying diagram, Fig. 314; shows the method of generating an epicycloid curve. The segments of the circle A, represent a portion of the pitch circle of a third wheel. The circle B represents the pitch circle of a fourth pinion. The circles C represent a circle the diameter of a pitch radius, viz., the circle by which the curve 1 in section lines is developed; and the circles B represent circles of the diameter of the pitched radius of the third wheel, rolled by the pitch diameter to develop an epicycloid curve. The peculiar features of this epicycloidal curve is that it will drive the radial line or the flank of a tooth—that is, the portion of the tooth below the pitched circle—with a practically uniform velocity, and, as a consequence, it has been adopted by watchmakers as the proper curve to give to the tooth of a watch. Unfortunately, however, few watchmakers have taken into consideration that there are other conditions to be met in the train of wheels and pinions in a watch. A fixed or arbitrary diameter is selected for the wheel or pinion. An epicycloidal cutter is formed, and the wheel tooth is cut so as to meet in a point at the outer diameter. If it meets in such a point, the operator in charge is satisfied that his tooth is correct, in that he has cut his wheel with what he terms an "epicycloidal cutter." In order to get this form, however, he has varied the angle of his tooth and slightly altered the curve with a diamond lap, in order to get what he terms a proper "epicycloidal tooth," which very much resembles the shape of the tooth 4 in Fig. 315.

In Fig. 314, I have developed curve 1, as a true epicycloidal curve, which practically explains itself. I have then taken circles approximating the shape of this curve and transferred them to Fig. 315, which shows the true epicycloidal curve attached to outline in the tooth numbered 1. Inspecting this shaped tooth, it will be found that in order to make a pointed tooth with an epicycloidal curve, the point extends beyond the arbitrary diameter selected for the diameter of the wheel, so that if the tooth should be made a true epicycloid, it would be flattened at the top. This would not do, however, in that it would be a bad form of tooth and quickly round on the top,

destroying in a measure the advantages derived from an epicycloidal curve. My attention was drawn to this matter at first from the fact that in a large number of watches having wheels formed by the same cutter we had different variations of rating at different intervals of the twenty-four hours, although the watches would practically correspond at the beginning and end of the twenty-four hours. Investigating the fact and finding that the escapement was correct and satisfactory—that the mainspring developed the true curve in running down and winding up—I concluded that the trouble lay in the shape of the wheel teeth. Examine the tooth in Fig. 314, lettered D: The shape of the tooth 1 is the correct epicycloid, and the shape of the outline 4 is what the workman termed a "nice looking tooth." Now, if when the point *a* of the wheel tooth contacted the pinion the rating was correct, and when leaving at *b* the rating was correct, then at all intermediate points the running of the watch must have been practically incorrect. I then realized the failure of attempting to make a true epicycloidal curve to a tooth. It will be seen by glancing at these again, that the lines are practically parallel, merely beginning the curves lower down, so that while it was an epicycloid, it was an epicycloid secured by reducing the diameter of the wheel or by making the space wider. I then determined on making an approximate curve—that is, a curve the outline of which is marked 5 in the tooth—which I found would follow in a measure the even workings of a proper epicycloidal curve. I have exaggerated the differences slightly here, in order to show the lines, but the curve is formed on much the same theory as the epicycloid, and approximates clearly its entire length, except at the extreme point, where it varies sufficient to make a departure at about the time that the next succeeding tooth of the wheel comes into engagement with the next succeeding pinion leaf, thus maintaining in a measure the practical uniformity of the epicycloid and providing a good wearing curve for the face of the tooth. No arbitrary rule of determining this curve can be selected, and it must be largely left to the discretion of the designer. It would need a sheet of paper much larger than a page of this book to draw the outline of an approximate curve for study and analyzing, but it would be well for the designer to draw his epicycloid curve on a very large scale—say one or two hundred diameters—and then curve the top *only* of his tooth so as to meet in a point, make the templet of a shape desired, and, by a pantograph engine, form his cutter.

Regarding the shape of the pinion: In Fig. 314, I have developed an epicycloid 2 by the same generating circle, and shown in Fig. 315 the outline of a pinion marked 2, that is made from this curve. In case the pinion was a driver, I have shown in Fig. 314 an epicycloid marked 3, developed by a generating circle, the diameter of which is the pitched radius of the wheel, and have made the outline of a

pinion tooth in Fig. 315, with the curve, and marked it 3. The inner circle of Fig. 315 in the pinion is the pitched circle—the outer circle is a circle supposed to be the diameter of the pinion, the addendum of which above the pitch circle is 1.50. It will be seen from a glance at Fig. 315 that the outlines of teeth developed by epicycloids 2 and 3 would extend beyond the arbitrary selected diameter and develop an immense amount of engaging friction, as it will be seen that “lead” takes place at 45 degrees before the line of centers, hence no watch would keep any uniform time in which there was an attempt to make the face of the pinion an epicycloid curve.

Look at the outline marked 6 of the pinion tooth: We have here a tooth which is only 1.25 addendum; or, in other words, the face of which is a semi-circle the diameter of the thickness of a tooth. This is all that is necessary, in that this factor above the pitch circle is merely a factor of safety. Examining the engaging teeth and pinion, it will be seen that “lead” can only take place slightly before the teeth reach the line of centers.—*T. F. Sheridan.*

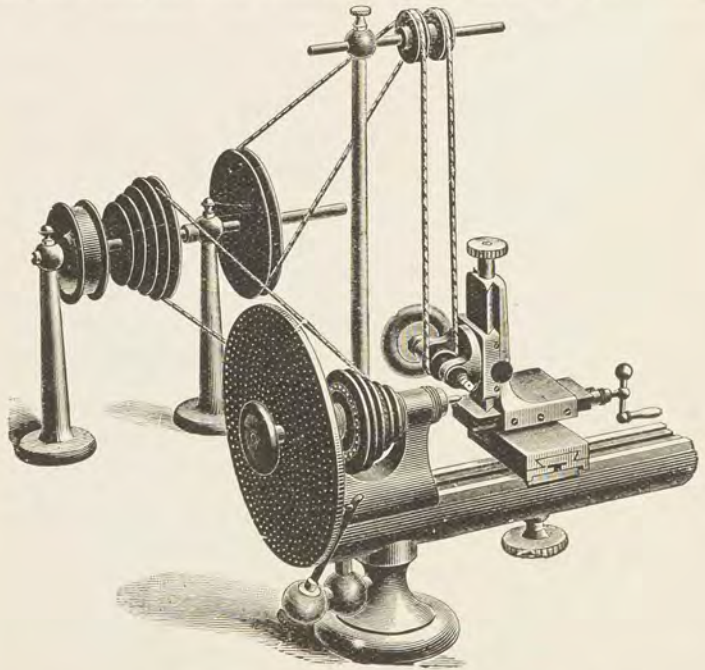

Fig. 316.

WHEEL CUTTER. The wheel cutter is a valuable addition to the lathe. Several different styles of these tools are made, each pos-

setting points of merit. They are designed for cutting all kinds of wheels and pinions used in key and stem-wind watches. When the cutter spindle is vertical the belt runs directly to it from the counter-shaft, but when horizontal the belt passes over idler pulleys held above the lathe. These idler pulleys are also used to run the pivot polisher. Fig. 316 illustrates the American Watch Tool Company's wheel cutter.

WHEEL VISE. Rose's patent wheel vise, shown in Fig. 317 is used for holding all kinds of watch wheels while undergoing repairs, such as putting in new teeth, removing rust from pinions, etc., and



Fig. 317.

for holding balance wheels while putting in or removing the screws, taking the hair spring or collet from staff, or for any work where the safety of the wheel is involved.

WIGWAG. The wigwag is used for polishing the shoulders of pinions, pinion leaves, staffs and pivots, and for numerous other operations. The formation of these tools differ according to the ideas of the various makers, but in principle they are alike. These tools are used extensively in all the American watch factories.

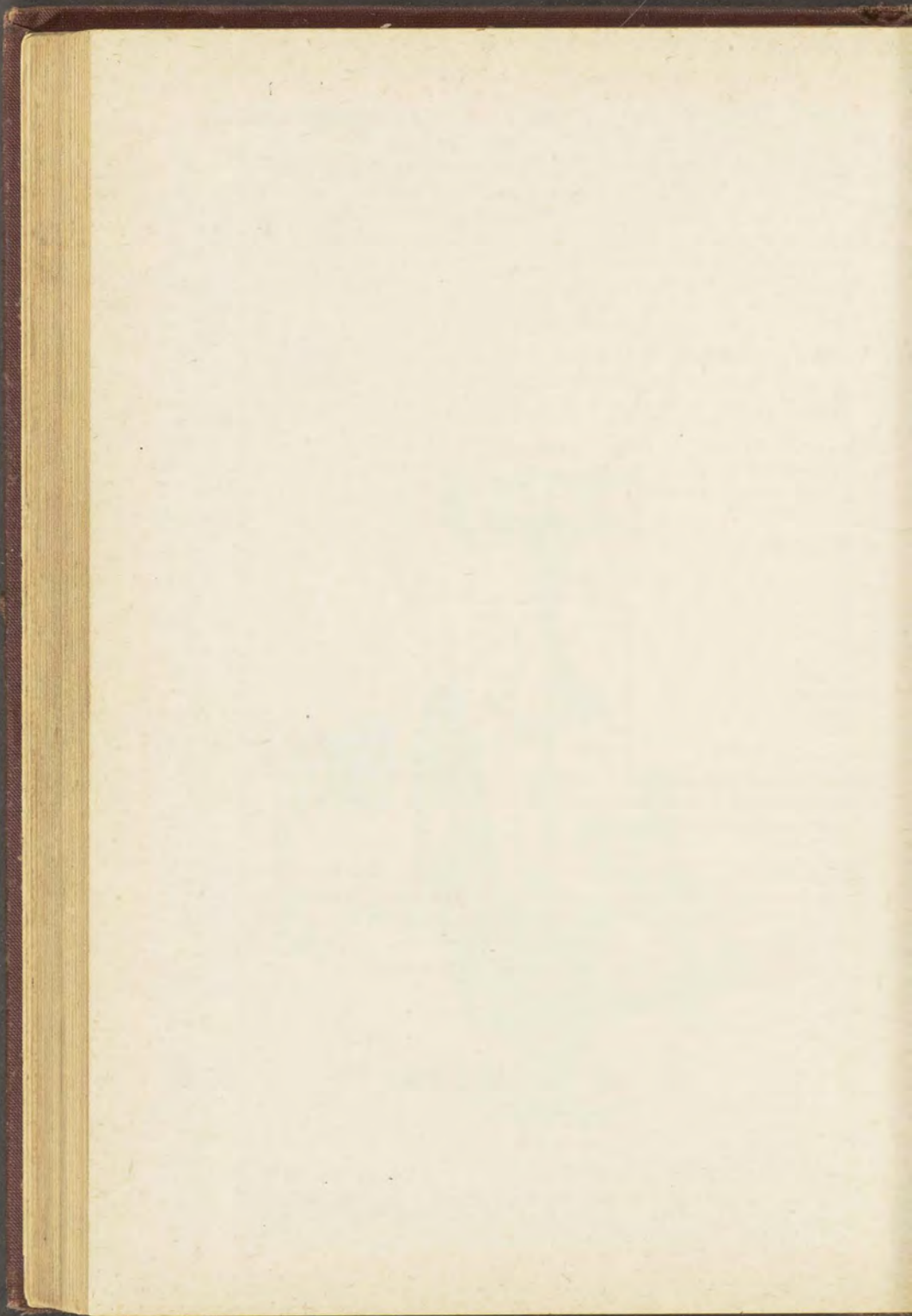

INDEX.

- Abbey, 5
 Absolute time 342
 Acceleration, 5
 Acids and salts, 6
 acetic, 6
 boric, 6
 chromic, 6
 hydrochloric, 7
 hydrofluoric, 7
 nitric, 7
 oxalic, 7
 prussic, 8
 sulphuric, 8
 tartaric, 8
 Adams, J. C., 8
 Addendum circle, 9
 Adhesion, 9
 Adjusting rod, 9
 Adjustment, 9
 heater, 12
 to positions, 9
 to isochronism, 11
 Alarm, 13
 Alcohol cup, 13
 lamp, 13
 All or nothing piece, 13, 302
 Alloy, 13
 non-magnetic, 15
 Bell metal, American, 15
 Japanese, 15
 for clock bells, German, 15
 Swiss, 15
 French, 15
 clock wheels, 15
 compensation balances, 13
 composition files, 15
 gongs and bells, 15
 knives and forks, 15
 opera glasses, 15
 spoons, 15
 tea pots, 15
 resembling silver, 15, 17
 'd, 17
- Alum, 6
 Aluminum, 17
 alloys, 14
 bronze, 14
 gold, 14
 silver, 14
 solder, 327
 zinc, 17
 Amalgam, 18
 Ammonia, 6
 phosphate, 6
 Ammonium sulphide, 6
 Anchor escapement, 18
 Angular gearing, 21
 velocity, 21
 Annealing, 22
 steel, 334
 Annular gear, 22
 Anode, 22
 Antique silver, imitation of, 165
 Apparent time, 313
 Aqua regia, 6
 Arbor, 22
 Arc, 22
 Arcograph, 22
 Arnold, John, 22
 Artificial gold, 17
 Assay, 22
 Astronomical time, 343
 Back rest, 310
 Balance, 22
 arc, 35
 bridge, 35
 compensation, 108
 protector, 36
 screw washers, 36
 sizes and weights of, 25
 spring, 37
 staff, 37
 to poise, 27
 Balances, expansion-contraction of 24
 Banking, 41
 error, 41

- Banking pins, 42
 screw, 42
 Barleys, 42
 Barlow, Edward, 42
 Bar movement, 42
 Barometric error, 42, 286
 Barrel, 43
 Barrel arbor, 43
 contractor, 43
 hook, 44
 ratchet, 44
 Bartlet, P. S., 44
 Bascule escapement, 44
 Baths, management of, 146
 brass, 146
 copper, 145
 gold, 147
 silver, 149
 nickel, 150
 Battery, bunsen, 140
 carbon, 140
 coupling, 142
 Daniell, 137
 gravity, 138
 Smee, 140
 wire, 144
 Beat, 44
 block, 41
 pins, 45
 Bell metal, 15, 17
 Bench, 45
 Benzine, 46
 Berthoud, Ferdinand, 46
 Louis, 47
 Bevel gears, 47
 Bezel, 47
 chuck, 47
 Binding wire, 47
 Bite, 47
 Blower, 47
 Blow pipe, 47
 soldering, 328
 Bluestone, 48
 Bluing, 48
 Bluing pan, 48
 Bob, 49
 Boiling-out pan, 49
 Borax, 6
 Boric acid, 6
 Bort, 50
 Rottoming file, 50
 Bouchon, 50
 Bow, 50
 compasses, 50
 pen, 50
 Boxwood, 50
 Brass, 17, 51
 black bronze for, 152
 bronze, 153
 etching fluids for, 51
 gold yellow for, 51, 154
 grained surface on, 150
 gray stain for, 155
 green bronze for, 155
 lacquers for, 51, 52
 magic polish for, 51
 polishes, 51
 polishing paste for, 51, 99
 steel blue on, 157
 silvering for, 150
 to blacken, 52
 to clean, 86
 Breguet, A. L., 52
 Bridge, 52
 Britannia, 17
 Broach, 52
 Broaching a hole vertically, 53
 Broaches, to solder, 53
 Brocot suspension, 52
 Bronze, antique, 152
 blue, 152
 brown, 153
 Chinese, 154
 for copper, 153
 steel, 153
 steel, 338
 medals, 15, 153
 ornaments, 15
 Japanese, 15
 liquid, 153
 manganese, 15
 Paris, 15
 Bronzing, 135
 fluid, 153
 Buff, 53
 Bullseye, 53
 Bunsen battery, 140
 Burnisher, 54
 Bush, 54
 Bushing pivot holes, 54
 punch, 55
 wheels, 55
 wire, 55
 Butting, 55
 Calipers, 56
 micrometer, 169
 Vernier, 175
 Callet, F., 56
 Cam, 56
 Cannon pinion, 56
 to tighten, 57
 Cap, 57

- Capped jewel, 57
 Capillary attraction, 57
 repulsion, 57
 Carbon battery, 110
 Carborundum, 56
 Cardinal points, 57
 Caron, Peter A., 57
 Carrier, 57
 Case hardening, 57
 springs, 57
 springs, adjustable, 58
 spring vise, 58
 stake, 58
 Cements, 58
 Cement, acid proof, 59
 alabaster, 59
 amber, 59
 brasses, 61
 chucks, 61
 engravers', 61
 fire-proof, 60
 for metal plates, 59
 for glass and brass, 59
 for glass and metals, 59, 60
 for knife and fork handles, 59
 for paper and metals, 60
 gold and silver colored, 60
 jewelers, 60
 metal, 60
 transparent, 60
 watchmakers, 61
 Center of Gravity, 64
 of gyration, 64
 of motion, 64
 of oscillation, 64
 punch, 64
 seconds, 66
 wheel, 66
 staff, 66
 Centers, 61
 female, 61
 male, 62
 Centering attachment, 62
 indicator, 63
 tool, 64
 Centrifugal force, 66
 Chain hook, 66
 Chalk, 67
 Chamfer, 67
 Chamfering tool, 67
 Chamois, 67
 Chimes, 68
 Chiming barrel, 68
 Chops, 68
 Chromic acid, 7
 Chronograph, 68
 Chronometer, 68
 Chronometer escapement, 68
 mungers, 75
 to examine, 74
 Chronoscope, 78
 Chrysolite, 17
 Chuck, 78
 adjustable, 78
 arbor, 80
 bezel, 80
 box, 85
 cement, 81
 conoidal, 81
 crown, 81
 dead center, 82
 drill, 82
 jeweling, 82
 pivoting, 82
 screw, 84
 shoulder, 84
 step or wheel, 84
 stepping device, 81
 taper, 85
 Circular error, 85
 Civil time, 343
 Clamps, 85
 Cleaning and repairing clocks, 104
 watches, 352
 Cleaning filigree, 323
 mainspring, 260
 pendulums, 86
 pickling and polishing, 86
 silver, 86, 323
 nickel, 86
 brass, 86
 Cleat, 90
 Clement, William, 90
 Clepsydra, 90
 Clerkenwell, 93
 Cliche, 93
 Click, 93
 spring, 93
 to mount, 93
 Clocks, 94
 Clock, annual, 99
 astronomical, 99
 calendar, 100
 Canterbury Cathedral, 94
 carriage, 100
 Cathedral of Metz, 96
 chiming, 100
 cleaning, 104
 DeVick's, 96
 Dover Castle, 96
 electric, 100
 equation, 103

- Clock, equatorial, 103
 Ferguson's, 99
 gravity, 183
 japanese, 201
 locomotive, 103
 master, 103
 mystery, 183
 Nuremberg, 96
 pivots, 105
 pneumatic, 103
 repairing, 104
 repeating, 103
 Strasburg, 95
 watch, 100
 watchman's, 104
 Clockmakers' Company, 106
 Club tooth, 106
 Clutch, 106
 Cock, 106
 Cole, James Ferguson, 106
 Collet, 107
 wrench, 107
 Colors of steel under heat, 337
 Compass, 107
 Compasses, 107
 Compensation, 107
 balance, 108
 alloy, 13
 curb, 111
 mercurial, 283
 pendulum, 111
 Concave, 111
 Contractor, barrel, 43
 Conversion table, 282
 Convex, 112
 Convexo-concave, 112
 convex, 112
 Conical pendulum, 111
 pivot, 111
 Conoidal, 111
 Contrate wheel, 111
 Conversion, 111
 Copper, 112
 brown stain for, 153
 silvering for, 156
 Corundum, 112
 Corundum wheels, 112
 Counter balance, 112
 Countermark, 112
 Countershaft, 112
 Countersink, 113
 Crank, 113
 Cremaillere, 112
 Crescent, 113
 Crocus, 114
 Crown-wheel, 114
 Crucible, 114
 Crutch, 114
 Crystal, 114
 Cumming, Alexander, 114
 Curb pins, 114
 Cusin, Charles, 115
 Custer, Jacob D., 115
 Cutter, wheel, 366
 Cycloid, 115
 Cylinder escapement, 115
 action, 116
 proportion, 117
 examination, 117
 Cylinder gauge, 175
 plugs, 123
 to pivot, 120
 Daniel battery, 137
 Damaskeen, 121
 Day, 121
 solar, 122
 sidereal, 122
 Dead beat escapement, 122
 Dead luster, 146
 Decant, 122
 Demagnetizer, 123
 Demagnetizing, 253
 Denison, E. B., 124
 Dennison, Aaron L., 124
 Dent, E. J., 125
 Depth, 125
 Depthing tool, 125
 Derham, William, 126
 Detached escapement, 126
 Detent, 126
 De Vick, Henry, 126
 Dials, 126
 drilling, 127
 double sunk, 129
 removing name from, 127
 removing stains from, 127
 reducing diameter of, 127
 repairing of, 127
 cleaning of, 128
 grinding backs of, 128
 luminous, 128
 Dialing, 128
 Dial work, 128
 Diamantine, 128
 Diamond drills, 128
 gravers, 128
 laps or mills, 129
 files, 129
 Diamond powder, 129
 Dimensions of mainsprings, 259
 Dipleidoscope, 129
 Dissolving soft solder, 327

- Dividing plate, 129
 Doctoring, 151
 Dog, 129
 Dog screws, 129
 Double roller escapement, 129
 Double sunk dial, 129
 Douzieme, 120, 168
 Draw, 130
 Draw plate, 130
 Drifting tool, 136
 Drills, 130
 Drill rest, 131
 stock, 131
 Drilling lathe, 131
 Drop, 132
 Drum, 132
 Duplex escape ment, 132
 roller, 134
 Dust bands, 134
 Earnshaw, Thomas, 134
 East, Edward, 135
 Electricity, tempering by, 339
 Electroplating, 135
 Electropon fluid, 143
 Ellicott, John, 157
 Emery, 157
 countersinks, 158
 files, 158
 pencils, 158
 wheels, 158
 End stone, 158
 Engine turning, 158
 Engraving blocks, 158
 Engraving on steel, 339
 Epicycloid, 159
 Equation of time, 159
 Equidistant lockings, 228
 Escapement, 159
 anchor, 18
 bascule, 44
 chronometer, 68
 Clement's, 19
 cylinder, 115
 dead beat, 122
 detached, 126
 double roller, 129
 duplex, 132
 frictional, 134
 gravity, 184
 horizontal, 192
 lever, 216
 resilient, 310
 pin pallet, 287
 pin wheel, 287
 recoil, 294
 single beat, 324
 Escapement, two pin, 344
 verge, 350
 vertical, 351
 Escapement error, 285
 Escaping arc, 160
 Escape pinion, 160
 wheel, clock, 104
 Eye glass, 190
 Facio, Nicholas, 160
 Ferguson, James, 160
 Ferric oxide, 88
 Ferrule, 161
 Fetil, Pierre, 162
 Fictitious silver, 17
 Files, 162
 composition, 14
 Filigree, to clean, 323
 Filing block, 162
 rest, 163
 Flux, 163
 soldering, 327
 Fly, 163
 Follower, 163
 Foot wheel, 163
 Forceps, soldering, 328
 Fourth wheel, 163
 French lines, table of, 282
 Friction, 163
 Frictional escapements, 164
 Frodsham, Charles, 164
 Frosting, 165
 Full plate, 165
 Fusee, 165
 Galileo, 166
 Gas heater, 167
 Gauge, 167
 cylinder, 175
 Douzieme, 168
 micrometer, 169
 pinion and wire, 171
 pivot, 289
 registering, 172
 staff, 173
 twist drill, 175
 wire, 171, 175
 Gerbert, 177
 German silver, to pickle, 87
 Gilding, 177
 steel, 150
 Gimbals, 177
 Glass polisher for steel, 339
 Goddard, Luther, 177
 Going barrel, 178
 fusee, 178
 Gold alloys, 178
 alloys, to pickle, 87

- Gold, artificial, 17
 baths, 147
 green, 148
 Nurnburg, 5
 recovering from baths, 152
 red, 148
 spring, 178
 Grained surface on brass, 148
 Graham, George, 178
 escapement, 179
 Graver, 181
 Gravity, 183
 battery, 138
 center of, 64
 clock, 183
 escapement, 184
 specific, 183, 331
 Gravimeter, 183
 Great wheel, 184
 Grignon, Thomas, 184
 Grinder, traverse spindle, 343
 Grossman, Moritz, 185
 Guard pin, 185
 Gyrate, 185
 Gyration, center of, 64
 Hairspring, 185
 stud index, 186
 Half plate, 188
 Hall mark, 188
 Hand, 190
 remover, 190
 Hardening and tempering steel, 335, 337
 Hardening liquids, 338
 Hardening steel in petroleum, 338
 Harris, Richard, 190
 Harrison, John, 191
 Hautefeuille, John, 191
 Henlein, Peter, 191
 Hooke, Robert, 191
 Horizontal escapement, 192
 Horological books, 192
 Hour glass, 196
 wheel, 196
 Houriet, F., 196
 Howard, Edward, 196
 Huyghens, Christian, 197
 clock, 198
 Hydrochloric acid, 7
 Hydrofluoric acid, 7
 Hypocycloid, 199
 Ice box, 199
 Idler, 199
 Impulse pin, 200
 Independent seconds, 200
 Index, 200
 Inertia, 200
 Ingold fraise, 200
 Involute, 201
 Iron, gold bronze for, 154
 Isochronal, 201
 Jacob, M., on acceleration, 5
 Jacot pivot lathe, 201
 Janvier, Antide, 201
 Japanese clocks, 201
 Jerome, Chauncey, 203
 Jewel, 203
 capped, 57
 holder, 203
 pin, 207
 setter, 208
 Jeweling, 204
 tool, 204
 caliper rest, 206
 Jodin, Jean, 208
 Joint pusher, 208
 Jurgensen, Urban, 208
 Jules, 209
 Kendall, Larcum, 209
 Kullberg, Victor, 209
 Lacquer, 209
 Lange, Adolph, 209
 Lantern pinion, 210
 Lap, 210
 Lepaute, J. A., 215
 Lepine movement, 215
 Lathe, 210
 Barnes, 214
 care of, 212
 Hopkins, 212
 Jacot pivot, 201
 Moseley, 211
 Rivett, 213
 Webster-Whitcomb, 211
 Le Roy, Julien, 216
 Pierre, 216
 Lever escapement, 216
 faults, 252
 Lever, straight line, 339
 Lime, 89
 Vienna, 351
 Liquids, hardening, 338
 Lockings, equidistant, 228
 Locking, 253
 Magnesia calcine, 7
 Magnetism, 253
 Magnets, to temper, 339
 Mainsprings, 256
 cleaning of, 260
 Mainsprings, dimensions of, 259
 Mainspring punch, 260
 winder, 260
 Maintaining power, 263

- Malleable brass, 17
 Maltese cross, 263
 Mandrel, 263
 Manganese bronze, 15
 Mass, 263
 Material cup, 263
 Matt for steel, 335
 Matting, 264
 Mercurial compensation, 383
 Meridian dial, 264
 Metals to pickle, 86
 Micrometer, 264
 caliper, 169
 Millimeter, 264
 Millimeters, table of, 282
 Milling cutters, 264
 fixture, 264
 Miter gears, 265
 Motion, center of, 64
 Moinet, Lewis, 365
 Moment of elasticity, 265
 Moment of inertia, 265
 Momentum, 265
 Moseley, Charles S., 265
 Motel, H., 266
 Motion work, 266
 Movement, 266
 box, 266
 cover, 266
 holder, 267
 rest, 267
 Mudge, Thomas, 267
 Mystery clock, 183
 Nickel baths, 150
 Nickel plating, 151
 Nickel, to clean, 86
 Nitric acid, 7
 Non-magnetic alloy, 15
 Non-magnetic watch, 267
 Oil, 268
 Oiler, 270
 Oil sink, 270
 Oil stones, 270
 dust, 270
 Oreide, 15
 Oscillation, center of, 64
 Overbanking, 271
 Overcoil, 271
 Oxalic acid, 7
 Oxidizing silver, 155
 Pads, soldering, 338
 Pantograph, 271
 Parachute, 274
 Pallet, 271
 staff, 271
 stones, 271
 Papers, watch, 360
 Peg wood, 274
 cutter, 46
 Pendant, 274
 bow, 274
 bow tightener, 274
 bow drill, 274
 Pendule watches, 274
 Pendulum, 274
 compensation, 111
 compound, 275
 conical, 111, 275
 error, 285
 laws of, 276
 length of, 280, 285
 oscillating, 275
 simple, 275
 spring, 286
 to clean, 86
 torsion, 276
 vibrations, 283
 Perron, M., 286
 Petroleum, hardening steel, 338
 Pickling of metals, 86
 German silver, 87
 gold alloys, 87
 Pillar, 286
 plate, 286
 Pinchback, 15
 Pinion, 286
 grinder, 286
 lantern, 210
 Pinion, and wire gauge, 171
 Pinions and wheels, 361
 Pin pallet escapement, 287
 Pin vise, 287
 Pin wheel escapement, 287
 Pins, steady, 334
 Pivot, 288
 gauge, 289
 Pivots, length of balance, 288
 play of, 288
 shape of, 288
 to polish, 40
 to turn, 40
 Pivoted detent, 292
 Pivoting cylinders, 120
 Plate, 292
 Plate, three-quarter, 342
 Pliers, watch bow, 359
 watch hand, 360
 Plunging, when hardening, 338
 Poising the balance, 27
 tool, 292
 Polisher, pivot, 289
 glass for steel, 339

- Polishing, 292
 agents, 81
 pivots, 40
 Poole, John, 292
 Potassium, bicarbonate, 7
 bitartrate, 7
 hydroxide, 7
 nitrate, 7
 sulphide, 7
 Potence, 292
 Potential energy, 292
 Powder, Belgium, 89
 gold, 89
 Prince's metal, 15
 Prussic acid, 8
 Pump center, 293
 Punch, center, 64
 Push piece, 293
 Quare, Daniel, 293
 Quarter rack, 293
 Quarter screws, 293
 Rack lever, 293
 Ramsey, David, 293
 Ratchet, 293
 barre', 44
 Rating nut, 293
 Raymond, B. W., 293
 Recoil escapement, 294
 Red stuff, 294
 Registering gauge, 172
 Regnauld, 294
 Regulator, 294
 Reid, Thomas, 294
 Remontoire, 294
 Repair clamps, 294
 Repairing and cleaning watches, 352
 Repeater, 295
 Repeating attachments, 299
 rack, 310
 slide, 310
 Resilient escapements, 310
 Resistance unlocking, 350
 Rest, 310
 Ring gauge, 311
 Riveting stake, 311
 Robert, M. H., on acceleration, 5
 Robin, Robert, 311
 Rocking bar, 311
 Roller remover, 311
 Romilly, M., 312
 Rose cutter, 312
 engine, 312
 Rouge, 313
 Rounding up attachment, 313
 Roy, Peter, 313
 Roze, A. C., 313
 Ruby pin, 313
 roller, 313
 Rust, to protect steel from, 338
 to remove from steel, 337
 Safety pin, 313
 pinion, 314
 Sal-ammoniac, 8
 Sapphire file, 314
 Scratch brushing, 89
 Screws, 314
 broken to remove, 314
 driver, 315
 extractor, 316
 head cutter, 316
 left handed, 315
 plate, 318
 tap, 318
 timing, 344
 Seconds hand remover, 318
 setting, 318
 split, 332
 sunk, 340
 sweep, 340
 Sector, 321
 Shellac, 321
 Sherwood, N. B., 321
 Sidereal clock, 321
 day, 322
 time, 343
 Silver, 322
 assay, 322
 bath, 149
 cleaning, 323
 distinguishing genuine, 322
 frosting, 323
 gold tinge to, 154
 oxidizing, 155
 paste, 89
 plating without battery, 156
 Silver, recovering from bath, 150
 separating, 322
 soap, 89
 to clean, 86
 Silvering for brass or copper, 156
 iron articles, 156
 Single beat escapement, 324
 Sizes of mainsprings, 359
 Sizes of watch movements, 359
 Skive, 324
 Slide rest, 324
 Snee battery, 140
 Snail, 325
 Snailing, 325
 Snap, 325
 Snarl, 325
 Snarling iron, 325

- Sodium bicarbonate, :
 hydroxide, 8
 phosphate, 8
 pyrophosphate, 8
- Solar time, 344
- Solders, 325
- Solder aluminum, 327
 gold, 227
 hard, 325
 silver, 326
 soft, 15, 327
 to dissolve soft, 327
- Soldering, 325
 blowpipe, 329
 fluxes, 327
 forceps, 328
 pads, 328
 stone set rings, 327
 tweezers, 349
- Specific gravity, 183, 331
- Spectacle tool, 331
- Split seconds, 332
- Sprung over, 332
- Square root, to extract, 278
- Staff, 332
 balance, to make, 37
 gauge, 173
- Stain, black, 152
 brown, 153
- Staining, 135
- Stake, 332
- Staking tool, 332
 and anvil, 333
- Star wheel, 334
- Steady pins, 334
- Steel, 334
 articles to temper, 338
 colors of, under heat, 337
 engraving on, 339
- Steel, glass polisher for, 339
 hardening and tempering, 335
 matt for, 335
 to anneal, 338
 to bronze, 338
 to gild, 148
 to harden in petroleum, 338
 to protect from rust, 338
 to remove rust from, 337
 to temper, 337
- Stepping device, 81
- Stogden, Matthew, 336
- Stop work, 339
- Straight line lever, 339
- Stud, 340
- Sully, Henry, 340
- sulphuric acid, 8
- Sunk seconds, 310
- Surprise piece, 340
- Sweep seconds, 310
- Table, 340
- Tail stock, 340
 half open, 341
 screw, 341
 traverse spindle, 341
- Tavan, Antoine, 341
- Tavernier, Louis, 341
- Temperature error, 285
- Tempering and hardening steel, 335
- Tempering by electricity, 339
- Tempering magnets, 339
- Testing needles, 341
- Tempering steel, 336
 articles, 336
- Third wheel, 342
- Thiout, M., 352
- Thomas, Seth, 342
- Three-quarter plate, 342
- Timing screws, 344
- Tin putty, 89
- Time, 342
 absolute, 342
 apparent, 343
 astronomical, 343
 civil, 343
 sidereal, 343
 solar, 344
- Tompion, Thomas, 344
- Touchstone, 344
- Tourbillon, 345
- Train, 345
- Transit instrument, 345
- Traverse spindle grinder, 345
- Tripoli, 89
- Turns, 348
- Tweezers, 348
 soldering, 349
- Two-pin escapement, 349
- Universal head, 349
- Unlocking resistance, 350
- Verge escapement, 350
 pin, 351
 wire, 351
- Vernier, 351
 caliper, 175
- Vertical escapement, 351
- Vienna lime, 351
- Villarceau, M., on acceleration, 5
- Vise wheel, 367
- Vulliamy, Benj. Lewis, 352
- Watch bow pliers, 359
- Watch case tool, 359
- Watch, 352

Watch cleaning and repairing, 352
Watch hand pliers, 360
Watch movements, sizes of, 359
Watchman's clock, 104
Watch papers, 360
Wheels, and pinions, 361
Wheel cutter, 366
Wheel, foot, 163

Wheel, fourth, 16
Wheel star, 324
Wheel, third, 342
Wheel vise, 367
White metal, 15
Wig-wag, 367
Wire gauges, 171, 172

REVERSIBLE

Direct Current Watchmakers' Lathe Power Motor.

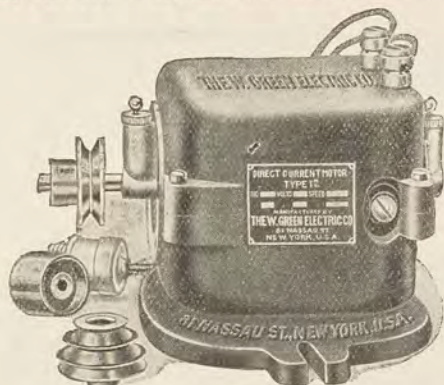

TYPE 12.

Replacing the old fashioned foot wheel. By its use the breaking of pivots by the unsteady action of the foot wheel is avoided. It does quicker, better and neater work, and pays its cost in a short while. This motor is compact, durable and powerful, and adapted not only for running a watchmaker's lathe but will be found useful for any light machinery in the modern repair shop. It runs quietly and smoothly in either direction of rotation and is **instantly reversible**. It is constructed of the best material with perfect workmanship in every detail, and is a fit accessory in finish for the finest watchmaker's lathe. The motor is completely enclosed and thoroughly protected from injury while its compact and square design **allows its use in confining places**, either vertical or horizontal.

Net Price 6 to 110 voltage.....	\$15.00
“ “ 115 to 250 “	17.00
“ “ Reversible switch.....	1.00
“ “ Speed Regulator.....	3.00

We are the largest manufacturers of motors for jewelers, dentists, and other light work; we also make small plating dynamos, platers' outfits, dynamotors, polishing and buffing lathes, watchmakers' demagnetizers, etc. We are constantly improving our product—that's why we lead. Send for bulletin of our entire line of new and up-to-date electrical specialties for watchmakers, jewelers and machinists.

The W. Green Electric Co.

81 NASSAU STREET,

NEW YORK, U. S. A.

When answering advertisements please mention this book.

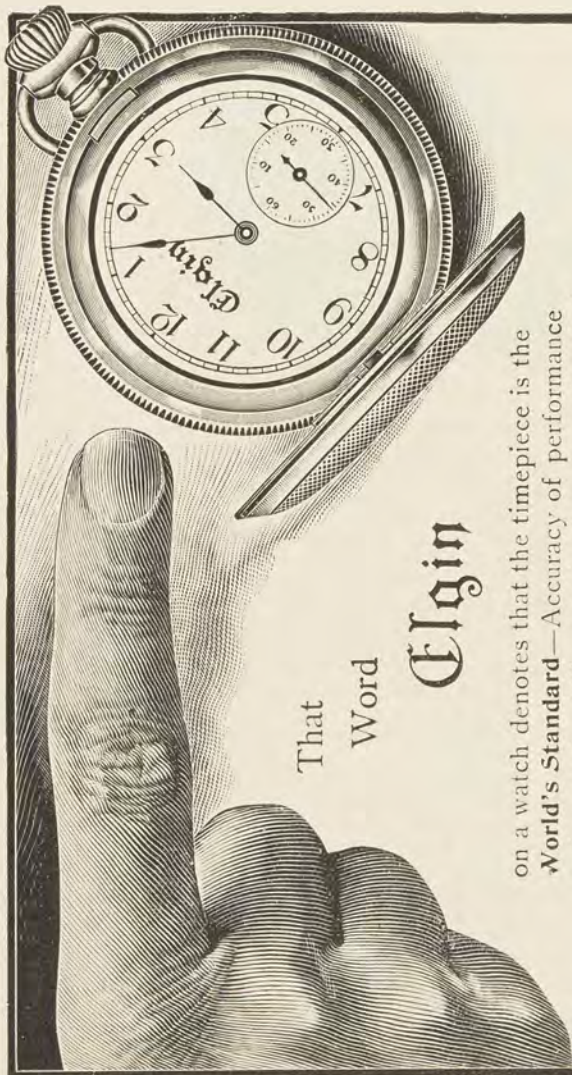

That
Word
Elgin

on a watch denotes that the timepiece is the
World's Standard—Accuracy of performance
and great durability are the proven merits of the

Full Ruby Jeweled Elgin.

Free Our booklet—"The Ways of
a Watch"—sent on request.

An Elgin watch always has the word "Elgin"
engraved on the works—fully guaranteed.

Elgin National Watch Co.,

Elgin, Ill.

E. & J. SWIGART

Headquarters for Watchmakers',
Jewelers' and Engravers'

TOOLS AND MATERIALS

AND OPTICAL GOODS

OF EVERY DESCRIPTION.

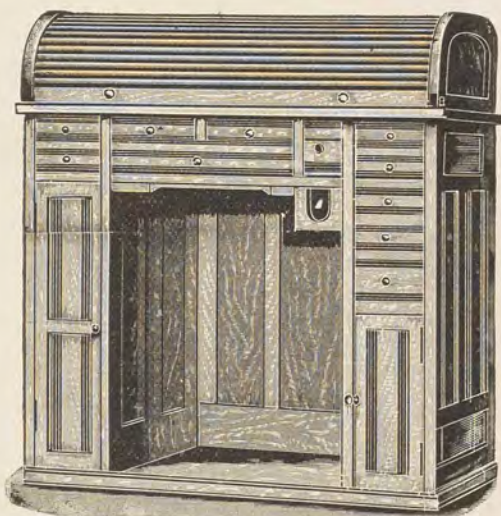

Work Bench No. 1.

We make a specialty of Watchmakers' Lathes and Benches, and have in stock at all times all desirable makes and sizes. **Our Illustrated Catalogue of Jewelers' Supplies and Optical Goods** sent on request free of charge. Send us your business card for a copy of the book which is full of interesting illustrations of goods at the lowest prices.

E. & J. SWIGART,
Cincinnati, O.

When answering advertisements please mention this book,

THE RETURNS WILL SURPRISE YOU



You can get price quotations for Old Gold and Silver as high (no higher) as ours elsewhere—but in the weighing and placing the value is where we differ, where we are higher.

Send a consignment to us on trial—the returns will surprise you.

You take no chances—we hold the consignment subject to your acceptance of our check. If you request same returned, we return it at our own expense.

THOMAS J. DEE & COMPANY,

REFINERS and SMELTERS

67-69 Washington St.

CHICAGO, ILL.



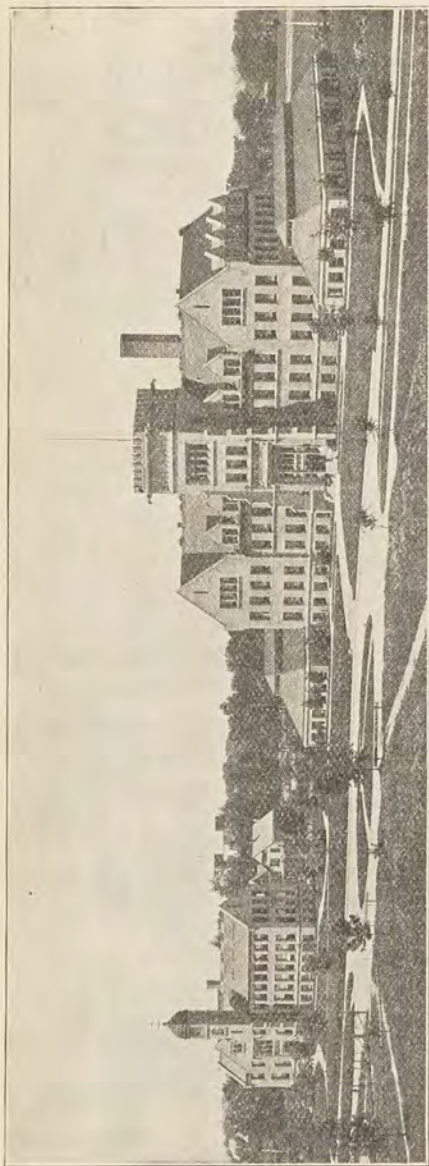

HOROLOGY HALL

BRADLEY HALL

SCHOOL FOR WATCHMAKERS

Every room in the Horological Building is used exclusively for instruction of Watch Work, Jewelry Work, Engraving, and Optics and the necessary offices to carry on the business of this kind, besides lecture rooms, cloak rooms and a room for Experimental Work.

Some facts about our school which we will gladly prove to anyone interested:

Rounded in 1888, the "pioneer watch school," Bradley Polytechnic Institute in 1897. More than 2,000 students have gone out from our school and are now at work in 44 States and Territories and 6 foreign countries. Our Horological Building is not equalled by any other in the world for space, light, ventilation and perfect fitness for the purpose. The equipment is the largest and best in America.

The instructors are experts and specialists and can give you all that is worth knowing in various branches. We have the largest horological faculty in America. The demand on us for workmen has been greater the last year than ever before, showing that students from a good school are thoroughly appreciated by the wide-awake jeweler. Graduates never fail to find good places. Our students say they can learn more with us in a year than in a store in seven years; and further, that they learn things better than they ever could in a store.

We teach Watchwork, Engraving, Jewelry and Optics?

Are you interested? Send for our catalogue and ask us all the questions you like; we'll tell you the truth, and let you judge for yourselves. Address **HOROLOGICAL DEPARTMENT, BRADLEY POLYTECHNIC INSTITUTE, PEORIA, ILL.**

TIMING MADE EASY

By using the

Marsh Screw Undercutters.



Is the best tool on the market for Timing and Poising Balances. Each tool has two separate cutters, which are made to use on either end. The larger size cutter for 12, 16 and 18 size balances, the small size for 6 and 0 balances. Each tool is well made, and cutters are finely tempered and do fine work, just the same as in watch factories. By removing cutter in this tool, it is very convenient for staking on hair-spring, or putting the same in beat.

Rollers can be staked on Balance Staff without any danger of breaking jewel pin. No watchmaker can afford to be without it, as it will save much valuable time.

Directions with each tool.

PRICE 75 CENTS. Extra Cutters, 25 Cts. Each.

Renders it impossible to break center jewels in putting on cannon pinions and hands.

Each holder is provided with rings for 10-0, 0, 6, 12, 16 and 18 size movements. Loosen the clamping lever and allow the center post to spring up; place on the base the proper size ring to fit the movement; place movement in position, press down firmly and lock the clamping lever. The center arbor will then be supported firmly with no danger to the pivots or jewels.

Holder with 6 Rings,
full Nickel Plated \$2.00



FOR SALE BY ALL JOBBERS.

CHAS. MARSH, MANUFACTURER,
ELGIN, ILL., U. S. A.

When answering advertisements please mention this book,

Electric Motor Polishing Heads

For Polishing, Buffing, Grinding, Etc.

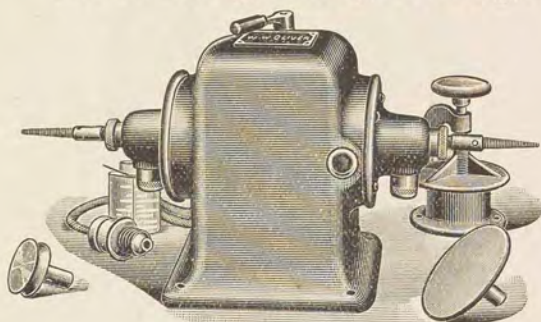

For Direct Current.

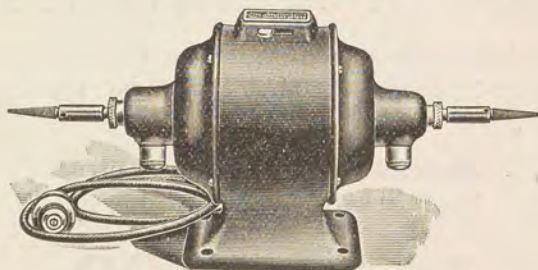

For Alternating Current.

SEND FOR OUR No. 5 BULLETIN.

MANUFACTURED BY

The W. W. Oliver Mfg. Co.

1488 Niagara Street, - BUFFALO, N. Y.

When answering advertisements please mention this book.



In 1854

WALTHAM WATCHES

awakened Europe to the fact that the American method of manufacturing produced the best watches.

Since that time the burden of proof has been successfully carried by

14,000,000

WALTHAM WATCHES

all representing the highest stage of the watchmakers' art.

MOSELEY

Made Continuously
for over 40 Years.



Imitated, but
never Equaled.

THE STANDARD of EXCELLENCE

Nothig is overlooked in their manufacture and no expense is spared to make them RIGHT. The Moseley Genuine Lathe of today is the result of years of painstaking, systematic and skilled endeavor to satisfy the exacting requirements of the most critical and experienced workmen.

Moseley Chucks are of the best quality and are made in all and half-sizes, covering every need of the watchmaker and repairer. These chucks and lathes were manufactured by us for years under the direct supervision of Chas. Moseley, the *inventor* of the "split chuck" and "draw-in spindle"; don't you think we ought to know something about chucks?

Moseley Lathes and Attachments, with plenty of Moseley Chucks are the secret of rapid and accurate work. They increase your earning power by enabling you to do more in a day. It thus pays big dividends to invest in them.

Write your Jobber or the Manufacturer for
Catalogue and Price List.

THE
Moseley Lathe Co.

ELGIN, ILL., U. S. A.

When answering advertisements please mention this book,

Watch Repairs

In this age of sharp competition, eternal vigilance is the price of success. Every stroke must count. Why be handicapped in your business by using cheap, inferior tools, when the reliable

WEBSTER-WHITCOMB LATHE

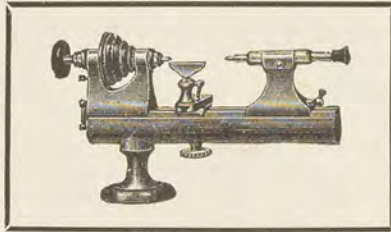

which has given the watch repairing world entire satisfaction for 30 years, can be bought at so low a cost?

We still maintain our **high standard of workmanship and finish.** Although our motto is "quality first, then low prices", we have in the past ten years, in consequence of increased production and improved methods and machinery, reduced our prices one third.

Who has done more for the craft than we? We claim:

Beauty, Scope, Solidity, Accuracy, Durability.

The AMERICAN WATCH TOOL CO.

WALTHAM, MASS.

When answering advertisements please mention this book.

In A Quandary

We dare say, that almost all jewelers are in a quandary as to what to do when a customer comes in the store and asks for something not in stock.

This can be obviated—all that is necessary is to have ALWAYS at your side one of our excellent catalogs.

This is no ordinary book; it does not show a conglomeration of any old-thing; on the contrary—it is gotten up to help Jewelers out of the quandary, when wanting something that they have not in stock.

This catalog of ours is the product of expert buyers, in all departments, and it truthfully shows you the newest and the best selling lines of merchandise. And the reliability of our house guarantees the price as being the lowest obtainable.

Address,

Oskamp, Nolting & Co.

Mammoth Wholesale Jewelers

413-415-417 Elm St. Cincinnati, Ohio.

When answering advertisements please mention this book.

PRACTICAL BOOKS

FOR

Watchmakers and Jewelers, Electroplaters,
Engravers, Opticians, Etc.

FOR SALE BY

HAZLITT & WALKER,

373 Dearborn Street, = CHICAGO, ILL., U. S. A.

Friction, Lubrication and the Lubricants in Horology. By W. T. Lewis. Illustrated with half-tones and drawings by the author. A work not only for horologists but for mechanics in general who are interested in the laws governing friction and lubrication. 96 pages. Paper covers, 75 cents. In art muslin, with aluminum side stamp..... 1 00

Modern Electro Plating. By J. H. Van Horne. The only work on the market that gives the proper attention to the modern tools, materials and methods used in preparing work for plating. It takes up matters from the beginning, and tells how to manipulate articles from the rough casting, forging or stamping, clear through all the processes of polishing, plating, etc., down to the final coat of lacquer. It explains how to make the plating solutions, how to keep them in order, and how to manipulate the work and the current so as to get the best results. It treats copper, brass, silver, alloys and gold solutions in a comprehensive way that enables the student or workman to understand the reasons for the various operations and make him in a large degree independent of rigid and exact formulæ, thus allowing him to make or modify the various solutions to exactly suit the nature of his work. 189 pages, with 27 illustrations, handsomely bound in cloth,....\$1.00.

The Evolution of Automatic Machinery as Applied to the Manufacture of Watches. By E. A. Marsh. This book is illustrated with seventy-two fine half-tones, made direct from photographs taken especially for this work. The author has been associated with the Waltham Factory for many years, has designed many of the machines himself, and is thoroughly conversant with their action and construction. He is now the assistant superintendent in the company's great factory. The book is a complete history of automatic machinery as used by this company, starting with the crude machinery of 1850 and taking it step by step up to the present time. The automatic machinery of this factory is noted throughout the world for its superior design and wonderful movements. Bound in silk cloth, with beveled boards, gilt top and gold side and back stamp. 140 pages. Price.... 2 00

The Acme Monogram Album. Contains 350 two-letter monograms of the most artistic character. Every letter in combination with every other letter. Unlike the cheap works now on the market, it does not consist of skeletons, which the engraver has to elaborate and fill in. They are complete monograms, ready to trace and transfer to the article, and are fitted for the finest goods. Mailed to any address on receipt of..... 10

The Watchmakers' and Jewelers' Practical Hand Book. a guide to the student and a workshop companion for the practical watchmaker. Hundreds of valuable suggestions from private formulas and the best authorities, together with hints on making certain repairs. An invaluable book for the workman. The most valuable book for the money ever offered to the trade. Fifth edition, revised and enlarged. Edited and compiled by Henry G. Abbott. Illustrated with 154 zinc etchings. 118 pages. Paper covers 35
Flexible Cloth 50

An Analysis of the Lever Escapement. By H. R. Playtner. The most thorough book on the subject ever produced. Written in a plain and comprehensive manner and thoroughly illustrated. Cloth binding, gold side stamp. 88 pages..... 50

Compensating Pendulums and How to Make Them. A Practical Treatise on the Construction of mechanically perfect Pendulums, for the use of watchmakers. By J. L. Finn and S. Riefier. Illustrated. Paper covers. 44 pages..... 35

Repairing Repeating Watches. By C. T. Etchells. A practical treatise on the subject and the only one in print. Fully illustrated. Paper covers. 32 pages 35

Prize Essay on the Balance Staff and Cylinder. By P. W. Eigner. This Essay took the first prize offered by the American Horological Society. Illustrated by numerous engravings. Paper covers. 24 pages 25

Staff Making and Pivoting. Practical directions for making new staffs from raw material. By Eugene E. Hall. Chapter I. The Raw Material; the Gravers; the Roughing out; the Hardening and Tempering. Chapter II. Kinds of Pivots; their Shape; Capillarity; the Requirements of a good Pivot. Chapter III. The Proper Measurements and How Obtained. Chapter IV. The Gauging of Holes; the Sideshake; the Position of the Graver. Chapter V. The Grinding and Polishing; the Reversal of the Work; the Wax Chuck. Chapter VI. Another Wax Chuck; the Centering of the Work. Chapter VII. The Finishing of the Staff; Pivoting; Making Pivot Drills; Hardening Drills; the Drilling and Fitting of New Pivots. Illustrated with 24 engravings. 48 pages. Paper Covers 25

The Art of Hard Soldering. By Henry G. Abbott. 69 pages; neat cloth binding. Fully illustrated. Contents: Lamps and Blowpipes; Character and Use of the Flame; Soldering Appliances. The Uses and Nature of Fluxes; Soldering and Alloys; The Practical Work. Cloth..... 50

Prize Essay on Watch Cleaning and Repairing. By F. C. Ries. This work took the first prize (offered by The American Jeweler), in competition with thirty-six other writers. Contents: Examination of the Movement; Taking Down; Fitting the Dial; Fitting Center Pivot and Bridge; Bushing; Endshake; Worn Center Pinions; Truing the Barrel; Repairing the Ratchet; Putting on Square on a Fuzee; Examination of Mainspring; Stemwind Mechanism; Examination of Train; Imitation Gilding; Pivots; Making Balance Staff; The Hairspring; Jeweling; Cleaning in General. Price..... 25

Watch and Chronometer Jeweling. By N. B. Sherwood. A complete treatise on this subject and the only one in print. Contents: Peculiarities of Gems Used in Making Jewels; Requisite Tools and How to Use Them; Shaping and Polishing the Jewel; Opening the Jewel; Setting the Jewel; The Endshake Tool; General Hints to the Repairer. Illustrated. Price 35

IF YOU WORK AT THE BENCH

We can supply you with Benches and everything pertaining to the Bench, as we are undoubtedly headquarters for everything in Watch Materials, Tools and Jewelers' Supplies, and in addition to our immense assortment of small tools we carry a large and varied supply of the best in Standard American and Imported Lathes at PRICES BELOW THE AVERAGE.



No. 172. Solid Oak Bench, \$22.00, less 6 per cent for cash.
Height to table 40 inches, total height 49 inches, width 26 inches, length 44 inches.

We make a specialty of Watch Material orders and rush them out without delay, having a large staff of experienced salesmen devoted exclusively to this class of our business. No orders too large for our capacity and none too small for our best attention.

If you are an established jeweler and will send us your business card or the necessary credentials our comprehensive tool, material and jewelry catalogues are yours for the asking.

OTTO YOUNG & CO.

Importers and Jobbers in Diamonds, Watches, Clocks, Jewelry, Tools, Materials and Optical Goods.

Wabash Ave. and Madison St., (Heyworth Bldg.) CHICAGO, ILL.

When answering advertisements please mention this book.

