



**JEWELRY AND WATCH
QUALITY STANDARDS MANUAL**

TABLE OF CONTENTS

Introduction	2
QA Sample Lead Time	3
Submission Requirements	4
Evaluation Disposition	7
Product Measurement	8
Stamping Requirements	12
Quality and Performance Standards	15
Construction Standards	16
Finish Standards	19
Metal Standards	20
Plating Standards	21
Gemstone/CZ Standards	23
Absolute Standards	26
Diamond Standards	27
Pearl Standards	28
Product Type Standards	29
Rings	29
Earrings	31
Bracelets, Necklaces, Pendants	32
Watches	34
Packaging	36
Claim Substantiation	37
Production Inspection	38
Pre-shipment Inspection	38
Post-shipment Inspection	40
Jewelry Inspection Sampling Plan	41
California Prop 65 Compliance	42
CPSIA of 2008 Compliance	43
Appendix A – Jewelry & Watch QA Standards Checklist	44
Appendix B – Glossary of Jewelry Terms	46

INTRODUCTION

Quality Assurance Means No Surprises

HSN's Quality Assurance (QA) program exists to ensure the proper execution of every product we buy and sell. This manual contains specific information concerning the minimum quality standards HSN expects in the product it purchases. In addition, we expect our partners to comply with all applicable legal requirements concerning the manufacture, sale and advertising of products. In certain instances, HSN standards may be higher than the stated legal minimums. It is the partner's responsibility to read and understand the published guidelines that pertain to the industry. These include but are not limited to:

- FTC Guidelines for the Jewelry, Precious Metals and Pewter Industries (16 CFR Part 23): <https://www.ftc.gov/enforcement/rules/rulemaking-regulatory-reform-proceedings/guides-jewelry-precious-metals-pewter>
- The National Gold and Silver Stamping Act (15 USC §§ 291-300): <http://www.gpo.gov/fdsys/pkg/USCODE-2009-title15/html/USCODE-2009-title15-chap8.htm>
- Lanham Act (15 USC §§ 1051-1127): <http://www.bitlaw.com/source/15usc/>
- The Jewelers Vigilance Committee (JVC): www.jvclegal.org
- The Consumer Product Safety Improvement Act of 2008. : <http://www.cpsc.gov/en/Regulations-Laws--Standards/Statutes/The-Consumer-Product-Safety-Improvement-Act/>
- California Proposition 65: <http://www.oehha.ca.gov/prop65.html>
- The information in this manual, in HSN's Supply Chain Requirements Manual <https://view.hsn.net/Documents/documents.aspx> and in the Master Terms and Conditions

Because quality cannot be inspected into products, it is the goal of the HSN Quality Assurance program to collaborate with our partners as early as practical in order to prevent defects. This partnership extends to design and materials selection before the product is made, and includes all points in the manufacturing, packaging, shipping and post-delivery processes. Therefore, it is within the purview of the HSN Quality Assurance program to maintain a close, direct partnership with our partners and their manufacturing facilities in order to support continuous improvement efforts and uphold the most efficient and effective manufacturing practices. It may be necessary at any time to visit a partner's facility to ensure we mitigate risks to delivering 100% acceptable product.

Our partners are expected to support our efforts throughout the supply chain to provide our customers with an unsurpassed purchase experience. Our partners are also expected to maintain world-class quality and delivery. Such expectations cannot be met unless our partners work with us and maintain a comprehensive quality program of their own. All shipments must be inspected for compliance before HSN ever sees the product.

HSN QA prepared this document to help you through the process of submitting products to HSN. This document contains general information. It should not be considered a definitive source of regulatory guidance.

Key Contacts

Please contact the following individual with any questions you have:

Jan Radcliffe | QA Manager: Jewelry | 727.872.7278 | jan.radcliffe@hsn.net

QA SAMPLE LEAD TIME

QA Sample Lead Time

The QA process is a critical part of making sure we maintain a reputation of trust and reliability with our customers— we must ensure that our customers get the best quality, greatest value, and safest products. The first step in that process is to submit the QA sample(s) and supporting documentation by the required number of days prior to your ship date.

The below table outlines the QA sample and product specification sheet lead time requirements.

Product Type	QA Sample and Product Specification Sheet Leadtime
Jewelry	28 days before ship date
Watches	21 days before ship date

Additional key milestones are outlined in Appendix B of the HSN Partner Supply Chain Requirements Manual.

<https://view.hsn.net/WebDocuments/documents/9-Appendix.pdf>

Maintaining proper timing of the QA process is important to ensure proper review of QA samples, specifications and proposed product claims. Failure to comply with the required lead time standards can result in fees for late QA samples. The Compliance section of the HSN Supply Chain Requirements Manual outlines the fees associated with late QA samples.

<https://view.hsn.net/WebDocuments/documents/8-Compliance.pdf>

SUBMISSION REQUIREMENTS

How to Submit Your Samples to QA

A complete sample submission for Jewelry and Watch products will consist of the following:

Complete product specification sheet submitted on the HSN Partner Portal

- Include all component and product details, including measurements
- Include all proposed care instructions, features and benefits, objective and performance claims, and all talking points for the on-air presentation.
- Include all plating information (goldtone, rhodium, etc.) if applicable.
- Include all stone types (gemstone, CZ, glass, etc.) and colors.
 - Carat weights are not required for imitation stones or opaque stones, however millimeter size is required.
- For eternity bands, complete spec sheet for size 7, then list the other ring sizes with stone count and total carat weight in the NOTES text box and in the Features and Benefits page.
- Include all claim substantiation, gemological lab testing, inserts, and instructions.
 - Gem ID testing required for all turquoise stones/components and quartz material.
 - HSN QA may require submission of Gem ID testing for any/all stones based upon its review of samples
- Include all required Prop 65 and CPSC compliance testing and documentation.
- Attach US Trademark registration documents (application from filer for pending marks)
 - If trademark owned by an entity other than the HSN Partner of Record, a letter of authorization from the owner of the trademark allowing use of the trademark must be provided.
- A photo image of the item showing all angles, components, and full color range must be uploaded. Color variants may be combined into one photo image document upload (see below examples).



Required Gemstone Identification and Disclosures

- Country of Mining/Origin: Mining (gemstones), Origin (pearls), Harvest/Collection (amber/cameos):
 - For Cameos, provide country of mining/origin” where shell is harvested. Additionally, provide country where shell is carved in the comments field of the stone information section.
- Stone Supplier: Name(s) of stone supplier(s), if not HSN Partner (list supplier name for each stone).
- Stone Type: natural, synthetic, simulated, manmade, etc.
- Stone Treatment Disclosure: All permanent and non-permanent treatments must be disclosed (irradiation, heat, doublets/triplets, etc.)

SUBMISSION REQUIREMENTS CONTINUED

How to Submit Your Samples to QA (continued)

Weight Tolerance for Karat Gold Purchased by Weight

- Benchmark weight must be entered into the product specification sheet.
- Stated weight equals finished (not cast) weight and must be inclusive of any applied surfaces (enamel and gemstones).
- There is zero tolerance for items that do not meet the guaranteed minimum weight.
- Locked weights **MUST** be entered into the spec sheet at least 8 business days before the ship/onsite inspection date.

Weight Tolerance for Sterling Silver Chain

- Gram weight for generic silver chain (necklaces and bracelets without gemstones) and cuff bracelets must be entered into the product specification sheet.
- Stated gram weight equals finished (not cast) weight.
- There is zero tolerance for items that do not meet the stated gram weight.

QA Sample Label

- Prior to sending a sample to HSN QA print and affix the sample label:
- Print the sample label found in the product specification sheet
- Affix label to the sample so that the item can be identified upon receipt

For guidance on how to create a specification sheet on the partner portal, please view the Product specification sheet tutorials. <https://view.hsn.net/Documents/Documents.aspx?dt=SpecSheetTutorials>

A printed guide is also available https://view.hsn.net/WebDocuments/documents/13_HowtoCreateaSpecSheet.pdf

NOTE: *The product specification sheets **MUST** be completed and submitted prior to sending samples to QA; samples without specification sheets will not be reviewed.*

SUBMISSION REQUIREMENTS CONTINUED**How to Submit Your Samples to QA (continued)**General Sample Requirements

- Representative of the final product from the production lot.
- Made using actual materials and stones.
- All color and size variants must be submitted at the same time.
- Include all product components with intended labeling.
- Include all inserts, instruction and any other material that will ship to the customer.
- Separate samples are required for all variants involving color, either metal or stone color.
- For length variants, all sizes are required for fit.
 - Specification sheets must be created so that each length/color variant is separated.
- Ring samples must be submitted in a size 7 (ladies) or size 10 (men's).
- Show Room samples must match the full approved gemstone color range.
- Reorders are expected to remain the same as the original order, including materials, design, construction, appearance, measurements, metal color, gemstone color range, features, findings, as well as partner-supplied packaging and literature.

Sterling Silver, Karat Gold, Alternative Metals

- For items with gemstones – three (3) mounted samples, or two (2) mounted samples and one (1) set of loose stones that accurately reflect the full color range.
- Non-gemstone items require two (2) samples to be submitted.
- For gold purchased by weight, one (1) sample must be submitted.

Gemstone Items

- Three (3) mounted samples, or two (2) mounted samples and one (1) set of loose stones that accurately reflect the full color range.
- Samples must be labeled numerically, lightest to darkest, (e.g. #1, #2, #3); Partner/factory must retain two sets of samples that match the QA samples. (One set sent to QA, one set for partner, one set for factory).

Shipment of QA Samples

- Ship all QA samples to HSN QA as outlined in the Product Samples section of the HSN Supply Chain Requirements Manual. <https://view.hsn.net/WebDocuments/documents/3-Product%20Samples.pdf>

After thoroughly reviewing the QA samples and specification sheet documentation, the HSN QA Product Evaluator will issue a written evaluation report to the partner. The partner then reviews and responds to the issues noted in the report and provides the information/materials requested.

NOTE: The appearance of the final product that will be shipped to the customer is also a concern of the HSN Merchandising team. Merchandise must not be changed in any way after it is approved by HSN QA. Changes include labeling, packaging, contents and components. Merchandise that has been modified will be returned. Contact HSN QA before any changes are made.

EVALUATION DISPOSITION

Evaluation Disposition

Products submitted to HSN QA will be reviewed by the QA evaluator and assigned one of the following evaluation statuses:

- Received: A physical product sample has been received, but the product specification sheet has not been submitted by the partner and/or approved by the HSN Merchandising team. An evaluation in Received status requires submission and approval of the product specification sheet prior to initiation of the formal QA evaluation process.
- Pending: QA has received a sample and a Merchandising-approved spec sheet. The evaluation is in process and/or there are open issues that require the partner to provide information, samples or corrective action.
- Approved: QA has evaluated the sample and found that it meets HSN standards. The product is approved to ship and will be inspected upon receipt in HSN Fulfillment Center.
- Approved Pending: QA has evaluated the sample and the only remaining open issue is the on-site inspection. Products placed into Approved Pending status require closure of the remaining issues before final approval. Upon successful completion of the on-site inspection and review of the inspection report, the evaluator updates the status to Approved.
- Rejected: QA has evaluated the sample and found that it does NOT meet HSN standards. Partners have the opportunity to correct the identified issues and resubmit samples/documentation accordingly.

PRODUCT MEASUREMENT

How to Measure

Measure by 1/16th inch fractions (flat ruler, soft tape, millimeter gauge).

When measuring an item, if measurement does not fall exactly on the measurement line, you must round **down** to the nearest 1/16th increment and enter into product specification sheet using the drop down selections available.

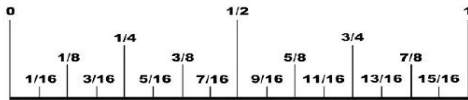

fraction	decimal	mm
1/16	0.0625	1.5875
1/8	0.1250	3.1750
3/16	0.1875	4.7625
1/4	0.2500	6.3500
5/16	0.3125	7.9375
3/8	0.3750	9.5250
7/16	0.4375	11.1125
1/2	0.5000	12.7000
9/16	0.5625	14.2875
5/8	0.6250	15.8750
11/16	0.6875	17.4625
3/4	0.7500	19.0500
13/16	0.8125	20.6375
7/8	0.8750	22.2250
15/16	0.9375	23.8125
1"	1.0000	25.4000

DIMENSIONS AND MEASUREMENTS ?

Chain Length: 18

Chain Width: 2

Chain Height: 1/16

Drop Length: 3/16

Drop Width: 1/4

Drape Length: 3/8

Extender Length: 2

Smallest Fit Size: 18

Largest Fit Size: 20

Other Dimension not listed:

INSERTS ?

Please indicate which (if any) will be included with the jewelry. Please

Rings

Measurements must be expressed as fractions of an inch within the specification sheet.

Shank width is measured as fractions of an inch and millimeters at the bottom/narrowest section of the shank.

DIMENSIONS AND MEASUREMENTS ?

Length: 11/16

Width: 7/8

Height: 5/16

Shank Width-Inches: 1/16

Shank Width-mm: 2

Other Dimension not listed:

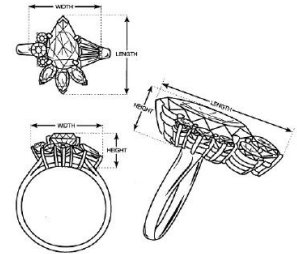

DIMENSIONS AND MEASUREMENTS ?

Length: 3/16

Width: 0

Height: 1/16

Shank Width-Inches: 3/16

Shank Width-mm: 4

Other Dimension not listed:

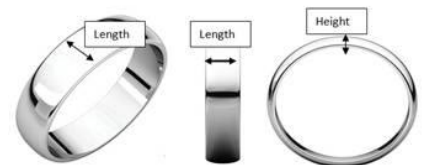

DIMENSIONS AND MEASUREMENTS ?

Length: 1/2

Width: 7/8

Height: 1/8

Shank Width-Inches: 1/2

Shank Width-mm: 12

Other Dimension not listed: see notes-individual measurements



NOTES

This is a set of 3.
Thin rings measure 1/8 x 7/8 x 1/8
Wide ring measures 1/4 x 7/8 x 1/8
Set measures 1/2 x 7/8 x 1/8

PRODUCT MEASUREMENT CONTINUED

Earrings

Measurement is based on the length and width, and height/depth as applicable.

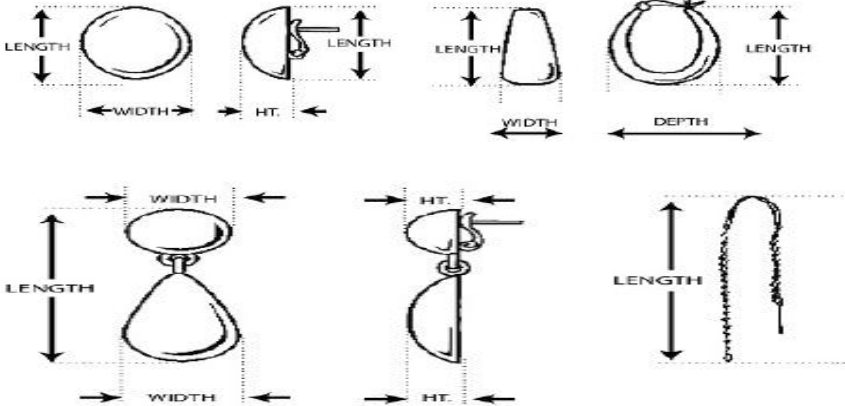

DIMENSIONS AND MEASUREMENTS ?	
Length:	1 1/4
Width:	1/8
Height:	1 1/4
Drop Length:	
Drop Width:	
Hoop Earring Inside Diameter:	1
Other Dimension not listed:	32 MM outside

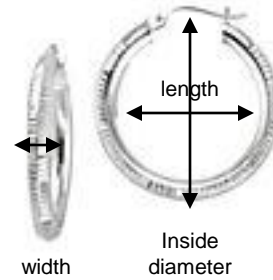

Necklaces/Pendants/Chains/Bracelets

Measurement is based on the “useable length” of the item. If the clasp does not contribute to the useable length, it is not included in the measurement. Include the length of extender, if applicable. For multi-chain designs, count the shortest length as the actual length measurement. For items with box or barrel type clasps, do not include the tongue (snapper) in the overall measurement.

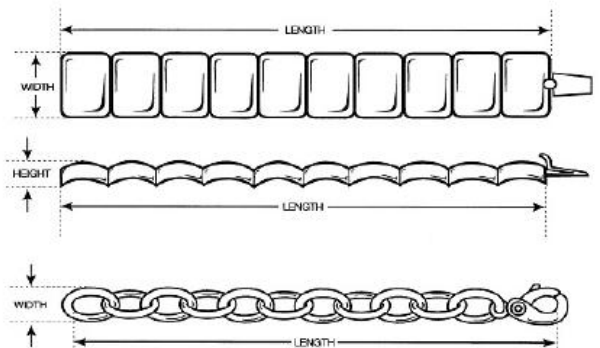
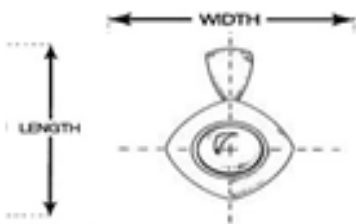
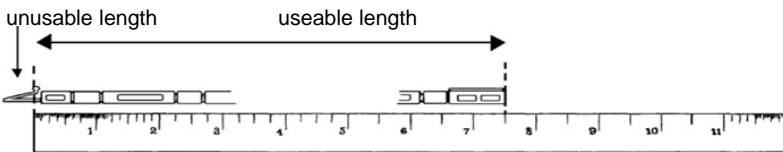

When measuring the length, lay the chain as flat and as straight as possible against a ruler. If the chain cannot lie completely straight, straighten it out as much as possible without distorting or damaging the piece.

For items with spring rings or lobster clasps, measure total length (end to end), minus the thickness of the spring ring or lobster claw “hook.”

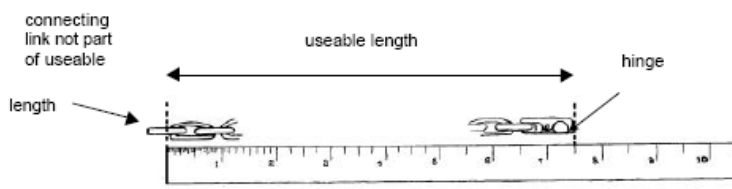
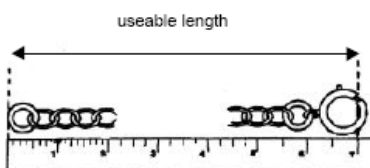

fold-over clasp

PRODUCT MEASUREMENT CONTINUED

Necklaces/Pendants/Chains/Bracelets (continued)

The measurement of an extender chain should include the useable length only.



Drop Measurements

Drape Measurements

DIMENSIONS AND MEASUREMENTS ?	
Chain Length:	18
Chain Width:	1/16
Chain Height:	1/16
Drop Length:	1 5/8
Drop Width:	13/16
Drape Length:	
Extender Length:	
Smallest Fit Size:	
Largest Fit Size:	
Other Dimension not listed:	



DIMENSIONS AND MEASUREMENTS ?	
Chain Length:	22
Chain Width:	3/8
Chain Height:	3/8
Drop Length:	
Drop Width:	
Drape Length:	8 1/2
Extender Length:	3 1/4
Smallest Fit Size:	
Largest Fit Size:	
Other Dimension not listed:	



Additional Measurements

Measure the length of the entire piece

Slide small "O" all the way down, then measure the internal circumference

Use a soft tape to measure the inside collar circumference

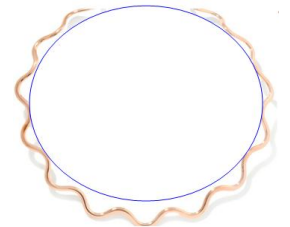
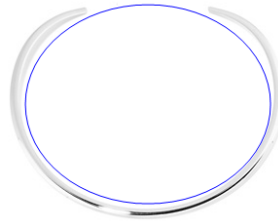

For Items with Toggle Closures

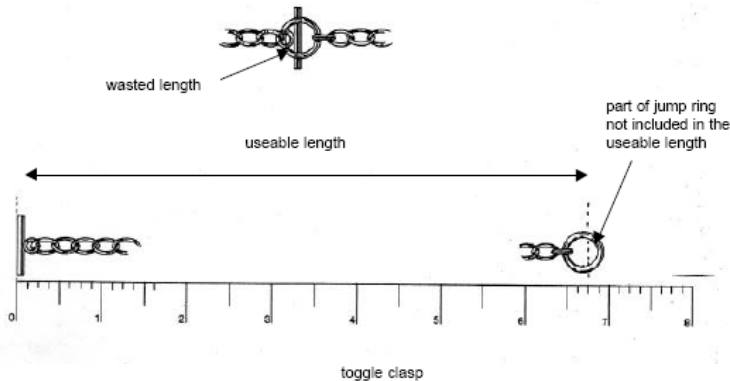

PRODUCT MEASUREMENT CONTINUED

Bangles and Cuffs

The inside circumference of bangle bracelets will be measured using the rolled paper method. Use a metal ruler to determine measurement. Do not use soft measuring tape, as they stretch over time and will not provide an accurate measurement.

1. Using a rolled up piece of paper, place rolled paper inside the bangle opening.
2. Allow the paper to unroll against the interior wall of the bangle.
3. Mark the paper at the exposed edge.
4. Unroll the paper and measure from the mark to the edge of the paper to determine the inside circumference.
5. Record in inches, measured to the 1/16th.

Cuffs should have a minimum opening/gap of 1" (length includes gap measurement). When measuring a cuff bracelet, first measure the gap (it must be at least 1"), then measure the inside circumference including the gap opening. The inside circumference including the gap opening and the length measurement are the same (7" in the example below).

Cuffs should be designed in such a way so that if squeezed for adjustment by the customer, stones do not become loose. For stretch, coil, adjustable/drawstring bracelets, measure the smallest or relaxed inside circumference.

For Charm Bracelets, provide the length and width of smallest and longest charm.

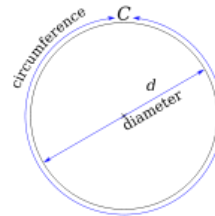
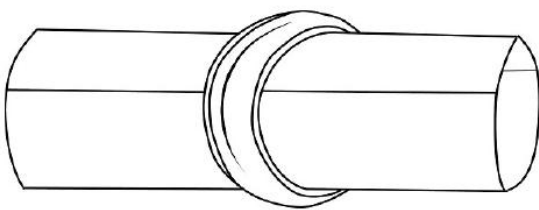

DIMENSIONS AND MEASUREMENTS ?		
Length:	7	▼
Width:	3/4	▼
Height:	1/4	▼
Cuff Inside Circumference:	7	▼
Gap Size:	1	▼
Smallest Fit Size:	5	▼
Largest Fit Size:	7	▼

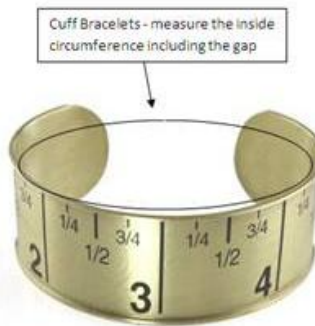

Pin/Brooch

Measurement is based on the width and length of the item.



STAMPING REQUIREMENTS

Trademark/Fineness Stamping

General

- Quality marks, trademarks, and country of origin (if required) are the ONLY marks to be stamped on jewelry. Manufacturing marks or factory marks (including, but not limited to, ring size, part number, carat weight) will not be accepted.
- Marks should be made directly onto the item by means of stamping, laser engraving, engraving, etc. All marks must be clear and legible.
- Any article that claims to be made wholly or partly of precious metal including gold, silver, and platinum group metals must bear a hallmark or fineness stamp which indicates the precious metal content and must be stamped with a U.S. registered trademark.
- The trademark and fineness stamp must appear in close proximity on the same component and consistent across variants.
- Trademark and fineness stamping is not required for fashion jewelry product (no precious metals)

Combined Metals

- Stamps on alternative metals combined with precious metals must follow the FTC Guidelines for Jewelry & The National Gold and Silver Stamping Act <http://www.gpo.gov/fdsys/pkg/USCODE-2009-title15/html/USCODE-2009-title15-chap8.htm> and <https://www.ftc.gov/enforcement/rules/rulemaking-regulatory-reform-proceedings/guides-jewelry-precious-metals-pewter>
- The acceptable stamps for stainless steel are: 316L, Stainless, S. Steel, and Stainless Steel.
- Clad” or “bonded” means a sheet of gold over sterling silver, making the silver indistinguishable. If your item is constructed in this manner, the amount of gold must be disclosed. The amount of gold must be stamped as a fraction representing the proportion of the weight of gold to the entire piece. If the gold is less than 50% (or ½) of the weight of the item, then the sterling stamp must go first. For instance: “Sterling Silver + 1/20th 14K” or “925 + 1/15th 10K”.
- For items with combined metals, both the lower and higher karat of one metal, or two different metals, must be marked on the piece and appear adjacent and equally legible and distinct (e.g. 14K & 18K, or 14K + .925).
- Items must be stamped with sterling silver or any of its designations (.925, 925, sterling silver, etc) first if there is 50% or more of sterling silver in the item, followed by the other metal(s) used. This is true of any metal. Whichever metal the item contains the most of, it must be stamped first in the fineness order.
- Copper & Silver items must be stamped with the predominant metal first followed by the secondary metal. E.g., Copper/.925, TM, Country of Origin.

Sterling Silver and Karat Gold Combinations – Order of Marks

Appearance	Metal Alloys	Example Hallmarks
Visually Distinguishable (different metal colors)	Yellow Gold and Sterling Silver or Yellow Gold and White Gold	The metal with the <i>heavier</i> proportion of weight must precede the other metal (e.g. .925 & 14K)
Visually Indistinguishable (same metal color)	White Gold and Sterling Silver or Clad/Bonded items	The metal with the <i>heavier</i> proportion of weight must precede the other metal. The <i>lighter</i> metal must also be preceded by a fraction that represents the metal’s proportion of the total weight of the piece (e.g. .925 & 1/5 14K)

STAMPING REQUIREMENTS CONTINUED

Country of Origin Stamping

- Country of origin must be stamped on all items made outside of the U.S.
- The country of origin stamp should be in close proximity to trademark and fineness stamp.
- The country name must be given in English either in full or using an acceptable abbreviation. Please consult Listing of International Standard Country Codes (ISO) Annex B http://search.usa.gov/search?affiliate=www.usitc.gov&query=country_codes
- In the event that the country of origin cannot be stamped onto the item due to physical limitations, you must obtain HSN QA approval to use a permanently printed non-adhesive hangtag affixed directly onto the merchandise (one hangtag required on earrings or “sets”).



- If country of origin changes for reordered items, existing inventory must be returned to the partner, or a new HSN item number assigned, as inventory cannot be mixed.
- If a product has different components which are manufactured or imported from a number of different countries, the different countries must be clearly specified by appropriately marking each component with its respective country of origin and these details noted in the product specification sheet.
 - E.g., when importing a pendant and chain set in which the pendant was made in China and the chain made in Italy, the pendant must be permanently marked “China” and the chain permanently marked “Italy.”

COUNTRY OF ORIGIN DISCLOSURE (?)	
Country of Origin:	Pendant:CN; Chain:Italy

Stamping Based On Jewelry Type

Bracelets

- A small hidden disc/tag should be used on stretch bracelets, continuous necklaces, and items without clasps or other applicable situations.

Earrings

- Each piece of an earring pair must be stamped.
- Fineness, trademark and country of origin stamps on earring posts are acceptable.
- Clutches and other earring backs must also be stamped unless they are non-removable (e.g. lever back).
- Country of origin is not required on clutch backs.

Pendants and Chains

- For pendants and chains, if the pendant is removable from the chain, both pendant and chain must have trademark/fineness stamps.

Rings

- For rings, stamps should be under the shoulders or as high up on the inside of the shank as possible.
- Marks should not be in the sizing area of ring shanks whenever possible.

Watches

- Stamping requirements for watches can be found in the Product Specific Requirements section for [Watches](#) in this document.



STAMPING REQUIREMENTS CONTINUED

Stamping for Alternative Metals

The below table summarizes the key stamping requirements for jewelry made from alternative metals (other than karat gold, silver and platinum).

Metal	Stamping Requirements
<p>Copper - Cu metallic element, ductile, malleable metal used as a component of various alloys (brass and bronze)</p>	<p>TM – Optional Fineness – Not Required COO - Required</p>
<p>Bronze alloy of predominantly copper and tin</p>	<p>TM – Optional Fineness – Not Required COO - Required</p>
<p>Brass alloy of predominantly copper and zinc</p>	<p>TM – Optional Fineness – Not Required COO - Required</p>
<p>Aluminum - Al metallic element, light in weight, ductile, malleable, and not readily corroded or tarnished</p>	<p>TM – Optional Fineness – Not Required COO - Required</p>
<p>Pewter malleable metal alloy, traditionally 85–99% tin, with the remainder consisting of copper, antimony, bismuth and lead</p>	<p>TM – Optional Fineness – Not Required COO - Required</p>
<p>Tin - Sn malleable, silvery metallic element. It is used to coat other metals to prevent corrosion and is a part of numerous alloys, such as soft solder, pewter, and bronze</p>	<p>TM – Optional Fineness – Not Required COO - Required</p>
<p>Pot Metal (Fashion Jewelry) white metal or die-cast zinc, mixture of alloys that consist of inexpensive, low-melting point metals used to make fast, inexpensive castings</p>	<p>TM – Optional Fineness – Not Required COO - Required</p>
<p>Stainless Steel A form of steel containing chromium, resistant to tarnishing and rust</p>	<p>TM – Required Fineness – 316L, Stainless Steel, S. Steel, Stainless COO - Required</p>
<p>Palladium - Pd rare silver-white ductile metallic element of the platinum group, used chiefly as a catalyst and in other alloys</p>	<p>TM – Required Fineness – Palladium or Pd COO - Required</p>
<p>Titanium - Ti chemical element with a low density; strong, lustrous, corrosion-resistant</p>	<p>TM – Required Fineness – Titanium or Ti COO - Required</p>
<p>Tungsten A metallic element which is hard, brittle and corrosion-resistant. Scratch, oxidation, and tarnish resistant</p>	<p>TM – Optional Fineness – Tungsten COO - Required</p>

QUALITY AND PERFORMANCE STANDARDS

All finished products should exhibit high quality workmanship and be free from any flaw or defect that could detract from the aesthetics, safety, or performance of the product.

Production products must conform to final approved spec sheet and be free from but not limited to the following defects:

- Dirt, stains, pitting, scratches, excessive glue
- Incompatible components, missing parts, improper fit
- Poor fit/finish, mismatched colors, misaligned patterns/labels
- Sharp edges/points, frayed cord/wires, poorly made repairs
- Symmetry must be maintained with each piece

Samples may undergo any or all of the testing listed below during the evaluation process.

Partners must ensure products are designed to meet these requirements before samples are submitted.

Test Type	Test Method Description	Requirement
Pull Test	Necklace/bracelet pulled in one continuous motion to test strength of stringing material, metal components (clasp, jump rings, wire wrapping, eye pins, and bead tips).	Item should not break and metal components should not open or bend with 2 pounds of pulling force
Pinch Test	Rings, bangles, cuffs, and hoop earrings are squeezed between fingers or palm of hand to test strength of metal casting.	Item should not bend and/or plating should not crack.
Plating Adherence	Piece of tape is attached to item then removed.	No plating or paint residue should transfer to tape.
Impact Test	Item is dropped onto hard surface.	Stones should not become loose and piece should be intact after completion of a 1 foot (12 inch) drop
Snag Test	Item is lightly dragged across various fabrics to detect any potential snagging.	No snagging that damages the fabric is permitted.
Rub Test	Item is rubbed on a piece of paper or a cloth to determine plating durability and colorfastness of stones.	No plating or dye can rub off onto paper or cloth.
Stone Security Test	Items are tapped between pointer finger and thumb to rattle test for loose stones. Stones may also be tested for security using tweezers.	Loose stones are not acceptable.
Function/Durability	Each jewelry item is tested for wearability, proper function, and durability.	Components and findings must function through a series of opening/closing that simulate everyday wear.
Plating/Fineness	XRF is used to measure the plating thickness and fineness quality of plated jewelry.	Plating must conform to the minimum standards for the product category and as documented on the specification sheet.
Gemstone ID	Each gemstone variety is examined via physical and gemological testing methods to verify gemstone species.	Identification must match information provided on the specification sheet.
Colorfastness	Items with color dyed stones, string or cord will be soaked in tap water, then dried on a white paper towel, to test for dye stability.	No transfer or leaking of color or dyes after soaking 18 hours in tap water.
Acetone/Alcohol Swab	Submerge or rub acetone or alcohol soaked swab over stone surface to test for dye.	No transfer or leaking of color or dyes.

CONSTRUCTION STANDARDS

General

All units within an HSN style number must be identical with regard to design, construction, color, and surface finish. Gemstones must fall within acceptable color ranges (see *gemstone standards*). All items must be consistent with regard to weights and measurements provided in the product specification sheet.

To drive consistency in quality and customer satisfaction, HSN requires the use of specific stringing materials for its products as noted below.

Softflex®

Softflex® beading wire is required for:

- All strung items that use flexible beading wire.
- All strung items that have gemstone beads and/or metallic elements.
- Any strung items that fail performance testing in our laboratory (your QA evaluator will be in contact with you when this occurs).

Key Requirements:

- Use of Softflex® must be disclosed on the product specification sheet.
- Softflex® flexible beading wire: 49 strand, 0.024 gauge.
 - If this size is too large for the drill hole, please move to the next smaller Softflex® size.
- Softflex® crimps: 3x3 or 2x3 (may use a crimp cover for a more finished look).
- Softflex® crimping pliers.
- Please ensure drill holes are straight and cleaned out before stringing.

To purchase Softflex® products, please contact Mike Sherman, (866) 925-3539, <http://www.Softflexcompany.com>

Stretch Magic™

Stretch Magic™ elastic cord is required for :

- All bracelets designed for stretch performance.

Key Requirements:

- Use of Stretch Magic™ must be disclosed on the product specification sheet.
- Stretch Magic™ elastic cord (0.5mm, 0.7mm, 0.8mm, 1.0mm, 1.2mm, 1.5mm, 1.8mm)
 - Use the thickest cord that will accommodate the size of the bead holes.
- Please ensure that drill holes are straight and cleaned out before stringing.
- Instructions for stringing and knotting are available at http://www.pepperell.com/Products/Stretch-Magic-Knot-Tying-Instructions_STRETCHVIDEO.aspx

To purchase Stretch Magic™ products, please contact Tom Murray, (800) 343-8114 x17, tomm@pepperell.com

Special T Glue (available through Softflex®)

- HSN recommends the use of Special T Glue where the gluing of components/stones is permitted and a strong adhesion is required.

To purchase Softflex® products, please contact Mike Sherman, (866) 925-3539, <http://www.Softflexcompany.com>

CONSTRUCTION STANDARDS CONTINUED**Casting/Construction**

- There can be no open seams, unfilled areas, cracks, excessive pitting in the joints, or excess solder.
- Castings must be free of parting lines, flashing, casting "fins," and excess metal from air bubbles.
- Visible porosity and holes in any amount or location is not acceptable.
- Spring loaded items such as spring rings and lobster claws must operate smoothly and close completely when released.
- Findings with Gallery work and airways must be clean, symmetrical, and of equal proportion.
- Jump rings on all products must be fully closed.
- Moveable parts must be fully functional and durable enough to withstand repeated operation.
- Findings such as bails, jump rings, and pin joint and catch, must be the appropriate size and weight according to the size of the item.

Soldering

- All soldered products must be of like karat with no discoloration.
- All jump rings on karat gold and sterling silver items must be soldered closed.
- Solder must not "freeze" any parts that normally are moveable (i.e. chain links, hinges).
- Soldered heads must be straight when viewed from the top, front, and side unless the design dictates otherwise.
- Solder seams must be smooth and neat. Excess solder, excessive pitting, or solder "running" out of the seam is not acceptable.
- Increased tolerance in smoothness/neatness of solder may be allowed for Handmade Jewelry
- Visible solder seams in bezels may be allowed for Handmade Jewelry, but there must not be gaps or excessive pitting in the solder.

Stone Setting

- Stones must be set level and consistent in height with respect to the design.
- Prongs must be even in shape, length, and placement and long enough to hold the stone(s) securely without snagging clothing.
- There should be no gaps between the prongs and the stones.
- Stones must be seated properly with the seat of the prong not exceeding one-third (1/3) of the prong thickness.
- Bezels must be smooth and even, in proportion to the size of the stone they secure and no gaps between the bezel and the stone.
- In channel settings, stone tables must be in the same plane, or follow a curve consistent with the design.
- Channel walls must be even and smooth.
- Stones should be set girdle to girdle.
- Stones should be set so that the culet is not exposed.
- Slight variation in the shape of prongs and bezels may be allowed for Handmade Jewelry as long as the security of the setting is not compromised.

Use of Glue in Stone Setting

- Glue cannot be used in setting gemstones except in the case of pearls (cultured and mabe), marcasite, inlay, certain applications with opaque stones such as, onyx and jade, or imitation stones used in fashion/costume items.
- If the design of the ring is bezel or prong set the stones must be secured by the metal and glue must not be used.
- Use of glue in setting any natural stone due to the nature of the design (e.g. briolette) must be pre-approved by HSN QA.
- Glue should never be visible through a stone.
- Imitation stones must be glued into the mounting and/or the setting(s) straight. Tipped stones are unacceptable.

CONSTRUCTION STANDARDS CONTINUED

Bezel Setting Examples

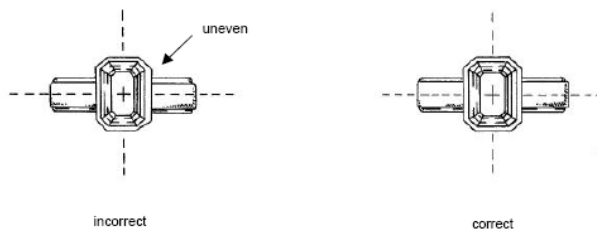
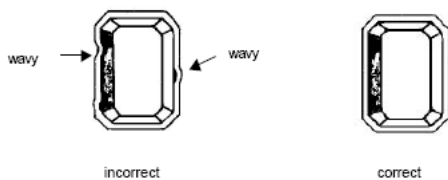

Bead Setting Examples

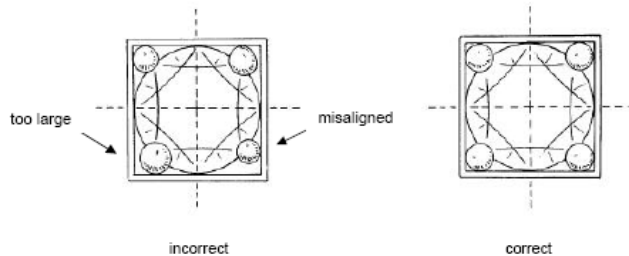
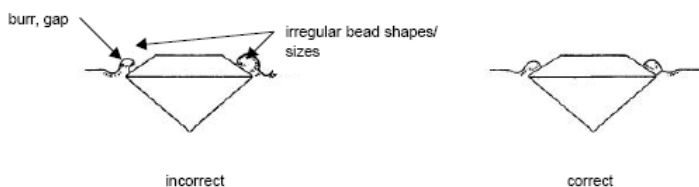

Channel Setting Examples

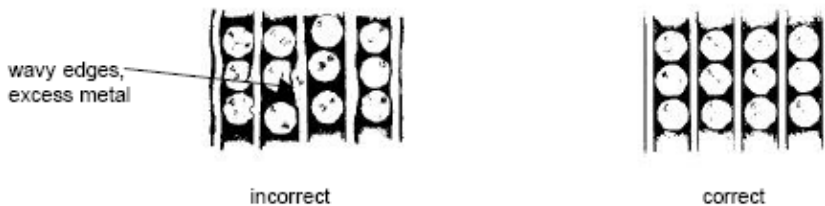
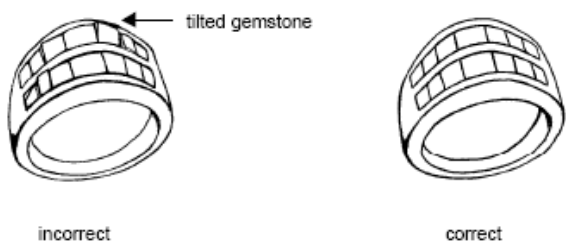

Pavé Setting Examples

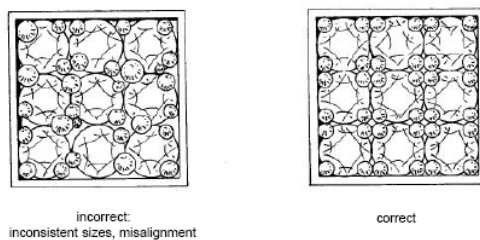
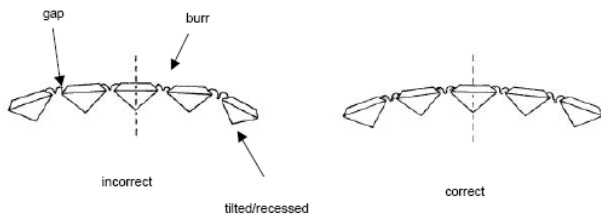

Prong Setting Examples

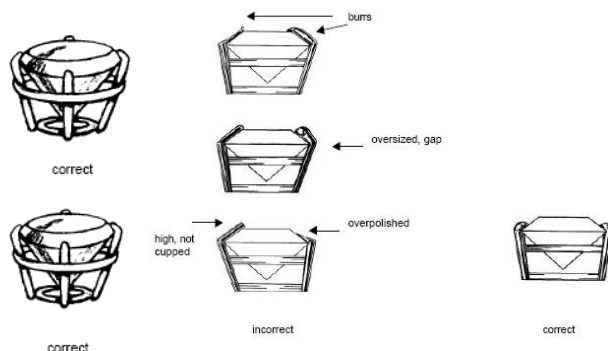
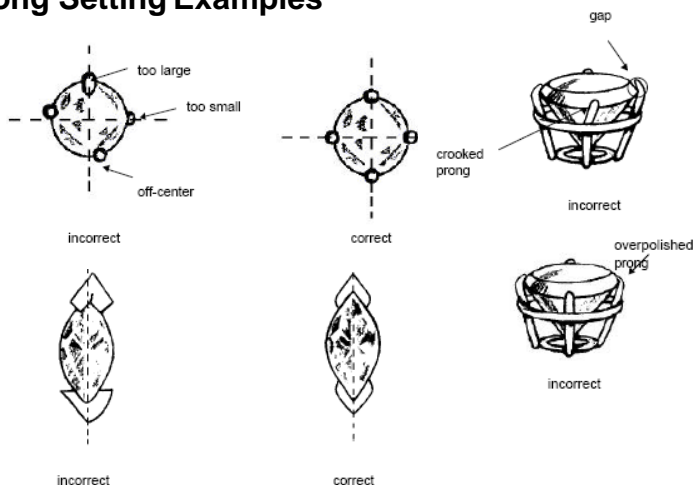

FINISH STANDARDS

Surface Finish/Polish/Special Finishes

- Metal surfaces must be of a high polish and free of scratches, tool marks, burrs, rough edges, excess metal/flashing, fire scale, porosity/holes, and surface distortion.
- Design details must be clean and distinct.
- Over polishing is unacceptable.
- Some polishing variations for Handmade Jewelry may be allowed within each piece and from piece to piece. However, tarnishing and fire scale are not acceptable.
- Satin, antiqued, rhodium finishes, etc, must be uniformly applied without overlapping onto adjacent areas where the finish is not intended.
- Enamel should be durable, lustrous, even in thickness, free of bubbles and cracks, visually uniform, and contained within the intended borders of the design.
- When the enamel is meant to be opaque, the area must be free of thinned areas that allow the metal surface to be visible.
- All jewelry items must be clean and dry with no oils, fingerprints, water spots, or polishing compound residue.
- Lint (from polishing buffs) under the prongs is unacceptable.

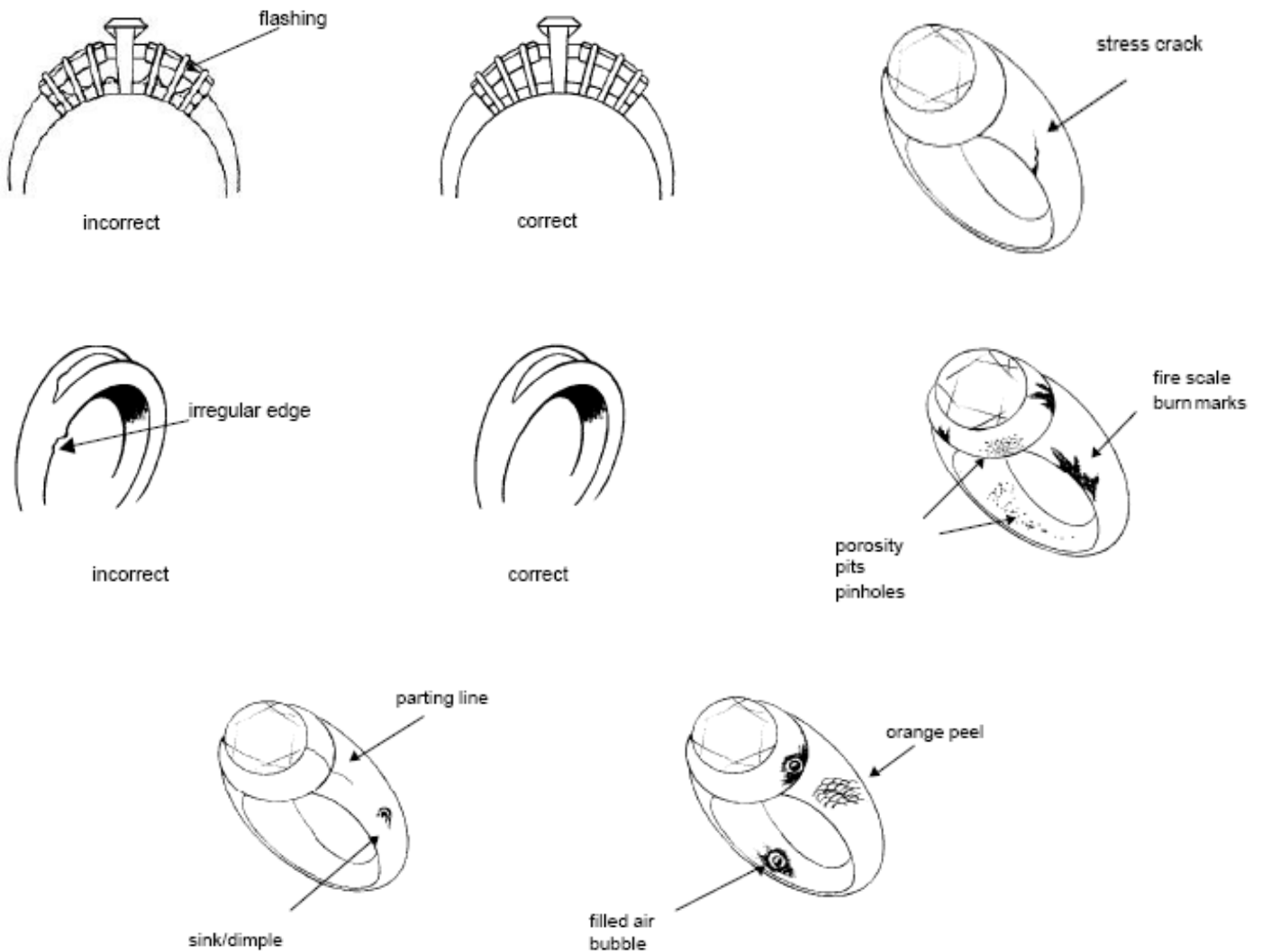

METAL STANDARDS

All jewelry products manufactured from any precious metal must meet the requirements established by the FTC.

<http://www.ftc.gov/enforcement/rules/rulemaking-regulatory-reform-proceedings/guides-jewelry-precious-metals-pewter>

HSN will periodically assay precious metal jewelry products; if the test results indicate that the item is non-compliant, independent third-party laboratory assay will be required (at Partner expense).

Karat Gold

- For karat gold items, the tolerance is ± 0.003 of the stamped fineness.
- For items constructed with solder (e.g. bracelets), the overall tolerance is ± 0.007 .
- The karat fineness of the solder may vary from the fineness of the jewelry item as long as the entire item falls within tolerances when assayed.
- For items manufactured with minor amounts of solder, the main (unsoldered) component is expected to fall within the normal ± 0.003 tolerance.

Karat	Fineness	Minimum Acceptable Fineness (without solder)	Minimum Acceptable Fineness (with solder)
10K	.4167	.4137	.4097
14K	.5833	.5803	.5763
18K	.7500	.7470	.743

Sterling Silver

- All sterling silver must assay at 92.5% sterling.
- For normal silver items (without solder) tolerance = .004 (e.g. 92.5% - .4% = 92.1%)
- With solder tolerance = .010 (e.g. 92.5% - 1.0% = 91.5%)
- Certain findings on silver jewelry are exempt from assay considerations. Components such as pin stems, and necklace and bracelet snappers (tongues) do not need to be sterling silver. In fact, HSN recommends (for strength and durability), that silver pin stems not be used. Nickel Silver pin stems are acceptable and preferred.
- The use of fine silver plate is allowed, but not required. Use of copper plated under layer is NOT allowed.

Platinum

- The FTC guidelines for platinum jewelry items must be followed <https://www.consumer.ftc.gov/articles/0294-platinum-jewelry>
- Product labeled as “platinum” without qualification MUST be at least 95% pure platinum
- Product labeled as between 500 Pt. and 950 Pt. must contain the corresponding levels of pure platinum (between 50% and 95% platinum).
- Products containing less than 50% pure platinum CANNOT be called platinum jewelry

Combined Metals – Sterling Silver & Karat Gold

- For detailed information, please refer to the FTC Guidelines for the Jewelry Industry <https://www.ftc.gov>, or JVC’s “The Essential Guide to the U.S. Trade in Advertising Jewelry of Silver in Combination with Gold” <http://www.jvclegal.org>

Alternative Metals

- Brand standards are established by HSN Merchandising. HSN suggests that you submit the alloy recipe for bronze or brass items prior to production. Trade names such as “Roman Bronze” and “Jewelry Bronze” are actually brass in composition; the actual metal used in the product must be correctly identified.
- Earring posts /wires must be plated with 14K or higher over .925 sterling post/wires to match metal color.

NOTE: *E-coat/anti-tarnish coating is required for products made from Copper, Bronze or Brass.*

Certain alternative metals such as Copper, Bronze, Brass and some plated Stainless Steel are subject to tarnish and as such are required to be packaged with Anti-tarnish tabs as described within the Brand Packaging Section of the HSN Supply Chain Requirements Manual.

PLATING STANDARDS

General Plating Standards

All products must meet the minimum thickness based on the plating designations (e.g. “gold plate,” “gold flash,” “heavy gold electroplate,” etc) as noted below.

Plating Thickness Definitions/Requirements		
Plating Description	Thickness (micro-inches/ mils)	Thickness (Microns)
Gold Flash/Wash	<7 (µin /mils)	(<0.175 Microns)
Gold Electroplate	>7 (µin /mils)	(>0.175 Microns)
Gold Plate	>20 (µin /mils)	(>0.5 Microns)
Vermeil	≥100 (µin /mils)	(>2.5 Microns)
Heavy Gold Electroplate	≥100 (µin /mils)	(>2.5 Microns)

- Plating thickness and fineness will be randomly tested by HSN QA.
- All plating procedures must be on file with HSN QA and include the types of metals used, as well as the plating thickness.
- Plated surfaces must be uniform in color and luster, and show no signs of peeling, cracking, tarnishing, or discoloration.
- Rhodium plating must not have any brown spots.
- Accent plating must not “overrun” onto adjacent areas.
- Use of fine silver plate is allowed, and may be required for certain brands. Use of copper plated under layer is NOT allowed

Vermeil

- Vermeil must have no less than 100 µin / 2.5-micron gold electroplating over sterling silver
- Vermeil must be stamped .925 fineness, it is not necessary to stamp a vermeil item with the fineness of the gold plate.
- Plating color must comply with HSN standards, color chips may be provided upon request.
- Vermeil items must be packaged with an anti-tarnish tab.

Black Vermeil	Chocolate Vermeil	Rose Vermeil
<ul style="list-style-type: none"> • Sub-plate is 3-5 mils of 100% Palladium • ≥100 mils of 18K gold plate • 3-5 mils black color layer plated on top of yellow gold layers 	<ul style="list-style-type: none"> • Sub-plate is 3-5 mils of 100% Palladium • ≥100 mils of 18K gold plate • 3-5 mils chocolate color layer plated on top of yellow gold layers • E-coat applied after chocolate layer 	<ul style="list-style-type: none"> • Sub-plate is 3-5 mils of 100% Palladium • ≥100 mils of 18K gold plate • Color layer may be used to match color chip
White Vermeil	Yellow Vermeil	
<ul style="list-style-type: none"> • Sub-plate is 3-5 mils of 100% Palladium • 2-3 mils of 100% Rhodium plating 	<ul style="list-style-type: none"> • Sub-plate is 3-5 mils of 100% Palladium • ≥100 mils of 18K gold plate • Color layer may be used to match color chip 	

PLATING STANDARDS CONTINUED

Absolute™

- Base materials: sterling silver and karat gold
- Absolute™ items must be stamped .925 fineness, it is not necessary to stamp the fineness of the gold plate.
- Plating color must comply with HSN standards, color chips may be provided upon request.
- Absolute™ items produced in sterling silver must be packaged with an anti-tarnish tab.
- Absolute™ items require rhodium plating.

Absolute™ White	Absolute™ Yellow	Absolute™ Yellow Vermeil
<ul style="list-style-type: none"> • Sub-plate is 3-5 mils of 100% Palladium • 2-3 mils of 100% Rhodium • Color matches rhodium color chip 	<ul style="list-style-type: none"> • Sub-plate is 3-5 mils of 100% Palladium • ≥100 mils of 18K gold plate • Color layer may be used to match color chip • Color matches yellow color chip 	<ul style="list-style-type: none"> • Sub-plate is 3-5 mils of 100% Palladium • ≥100 mils of 18K gold plate • Color matches yellow color chip

Technibond®

- Base material is sterling silver.
- Technibond® items must be stamped .925 fineness, it is not necessary to stamp the fineness of the gold plate.
- Plating color must comply with HSN standards, color chips may be provided upon request.
- Technibond® items must be packaged with an anti-tarnish tab.

Technibond® Black	Technibond® Chocolate	Technibond® Green
<ul style="list-style-type: none"> • Sub-plate is 100% Palladium 3-5 mils • ≥40 mils of 18K gold plate • 3-5 mils black color layer plated on top of yellow gold layers • Color matches black color chip 	<ul style="list-style-type: none"> • Sub-plate is 100% Palladium 3-5 mils • ≥40 mils of 18K gold plate • 3-5 mils chocolate color layer plated on top of yellow gold layers • E-coat applied after chocolate layer • Color matches chocolate color chip 	<ul style="list-style-type: none"> • Sub-plate is 100% Palladium 3-5 mils • ≥40 mils of 18K gold plate • 3-5 mils chocolate color layer plated on top of yellow gold layers • E-coat applied after chocolate layer • Color matches green color chip
Technibond® Platinum	Technibond® Rose	Technibond® Yellow
<p>Layers noted are in the order of plating</p> <ul style="list-style-type: none"> • Layer 1: ≥40 mils of Fine Silver • Layer 2: 3-5 mils of 100% Palladium • Layer 3: 3-5 mils of 100% Platinum • Layer 4: 3-5 mils of 100% Rhodium • Color matches rhodium color chip 	<ul style="list-style-type: none"> • Sub-plate is 100% Palladium 3-5 mils • ≥40 mils of 18K gold plate • Color layer may be used to match color chip • Color matches rose color chip 	<ul style="list-style-type: none"> • Sub-plate is 100% Palladium 3-5 mils • ≥40 mils of 18K gold plate • Color layer may be used to match color chip • Color matches yellow color chip

Plating Testing Facilities

- HSN has approved the testing facilities listed below. Other qualified testing facilities may be used, but must be approved by HSN QA prior to testing.

Approved Plating Testing Facilities		
<p>Underwriters Laboratories (UL) 10 Water Street Enfield, CT 06082 Tel: 860-749-8371 www.UL.com</p>	<p>Mutual Cornell 136 Corliss St Providence, RI 02904 Tel: 401-274-9998 www.mutualcornell.com</p>	<p>Intertek North America 545 E Algonquin Road, Suite F Arlington Heights, IL 60005 Tel: 847-871-1020 www.intertek.com</p>
<p>Bureau Veritas Consumer Products Services 100 Northpointe Parkway Buffalo, NY 14228 Tel: 716-505-3300 www.bureauveritas.com</p>	<p>SGS U.S. Testing Company 291 Fairfield Avenue Fairfield, NJ USA 07004 Tel: 973-575-5252 www.sgs.com</p>	<p>Intertek Asia 11/F., Garment Centre 576 Castle Peak Road Kowloon, Hong Kong Tel: (852) 2173 8836 www.intertek.com</p>

GEMSTONE AND CZ STANDARDS

Clarity

- Clarity will be evaluated using “eye visible” criteria. Loupes and other magnification will be used only for defect clarification purposes.
- Must be free of scratches, polishing lines, chips, cracks, and abrasions.
- No obvious defects on the table, crown, girdle, or culet will be acceptable.
- The degree of acceptable visible inclusions will be determined from the approved QA samples.
- Any gemstone with an internal or surface flaw that threatens the stone’s structural integrity is unacceptable.

Color

- Color ranges for gemstones, synthetics, simulants, and organic material cannot exceed two tones of saturation.
- No significant banding of color, feathers, or dark inclusions evident during a face-up inspection will be accepted.
- In a multi-stone item, gemstones of the same type must match in color/tone/intensity/saturation, clarity, polish, and luster, unless otherwise specified.
- Stone color, size, and placement in samples should match production.
- Matching components of a suite (earring, ring, bracelet, necklace, etc.) must match in color range.

Carat Weight

- Total carat weight tolerance will be verified at inspection.
 - 5% for all natural gemstones, stated in carat weight and MM sizes.
 - 15% for synthetics, stated in carat weight and MM sizes.
- Jade, opals, opaque stones, and simulated stones, are measured in MM rather than total weight. Allowable tolerance is +/- 1/2 MM.
- Moissanite ® stones and Absolute™ CZ use the [Diamond Equivalent Weight Chart](#) to describe stone weight, rather than actual stone weight. The partner should determine the diamond equivalent weight by using the [conversion chart](#) and enter “DE weight” in the stone section of the product specification sheet.
 - Stone weight tolerance is not applicable for Absolute™ and Moissanite ® products.
- All stones must match in millimeter size.

Cut/Finish

- Stones must be symmetrical and properly cut.
- Faceting and depth must be proportionate to the shape, size, and type of material of the stone, and must be consistent throughout the shipment.
- Stone girdles must be polished.
- Off-center tables, poorly cut culets, or non-parallel facet arrangements (step cuts) may be cause for rejection.
- Windowing of stones when judged perpendicular to the table must be minimized.

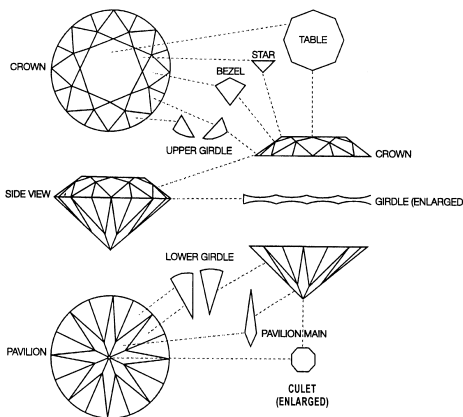

GEMSTONE AND CZ STANDARDS CONTINUED**Gemstone Identification**

HSN QA will conduct in-house gemstone confirmation testing on the samples provided.

Partner's may be asked to submit a certified gemological laboratory report to conclusively identify the nature of a stone.

- All gemstone Today's Special "TS" items may require Gemological Institute of America (GIA) testing documentation.

NOTE: *Identification of gemstones may require destructive testing of the samples submitted.*

Turquoise Materials

- A certified gemological laboratory report from GIA must be submitted to confirm materials as turquoise.

New /Unique Gemstones and Materials

- A certified gemological laboratory report from GIA must be submitted for any new gemstones or unique materials not previously sold at HSN. This report is required to support the identification and authenticity of the material.

Gemstone Treatment

HSN Partners must fully disclose whether a gemstone has been treated or enhanced in any manner, or requires unusual care.

It is deceptive to fail to disclose treatments that:

- are not permanent
- create special care requirements
- are permanent, and have a significant effect on the stone's value

Unacceptable Gemstone Treatments

- Colored oiling of emeralds
- Class 3 glass filled stones
- Non-permanent dye or color

GEMSTONE AND CZ STANDARDS CONTINUED

Diamond Equivalent Weights

The chart below provides the diamond equivalent weights (DE) required for cubic zirconia products sold at HSN

CUT	MM SIZE	D/E WT	CUT	MM SIZE	D/E WT	CUT	MM SIZE	D/E WT	CUT	MM SIZE	D/E WT
ROUND	1	0.005	EMERALD	5 X 3	0.25	TRILLION	3 X 3	0.1	STRAIGHT BAGUETTE	3 X 2	0.08
	1.25	0.01		6 X 4	0.5		3.5 X 3.5	0.15		4 X 2	0.1
	1.5	0.015		7 X 5	1		4 X 4	0.25		5 X 2	0.15
	1.75	0.02		8 X 6	1.5		4.5 X 4.5	0.35		5 X 2.5	0.18
	2	0.03		8.5 X 6.5	2		5 X 5	0.5		5 X 3	0.25
	2.25	0.04		9 X 7	3		5.5 X 5.5	0.75		6 X 2	0.2
	2.5	0.06		10 X 8	4		6 X 6	1		6 X 3	0.35
	2.75	0.07		11 X 9	5		7 X 7	1.5		7 X 2	0.35
	3	0.1		12 X 10	6		8 X 8	2		7 X 3	0.5
	3.25	0.13		OVAL	5 X 3		0.25	SQ PRINCESS		1.5 X 1.5	0.02
	3.5	0.15	5 X 4		0.35	1.75 X 1.75	0.03		3 X 1.5 X 1	0.03	
	3.75	0.2	6 X 4		0.5	2 X 2	0.05		3 X 2 X 1.5	0.05	
	4	0.25	7 X 5		0.75	2.25 X 2.25	0.07		3.5 X 1.5 X 1	0.05	
	4.25	0.28	7.5 X 5.5		1	2.5 X 2.5	0.1		3.5 X 2 X 1.5	0.08	
	4.5	0.35	8 X 6		1.25	2.75 X 2.75	0.125		4 X 2 X 1.5	0.1	
	4.75	0.4	8.5 X 6.5		1.5	3 X 3	0.15		5 X 2 X 1.5	0.15	
	5	0.5	9 X 7		2	3.5 X 3.5	0.25		5 X 3 X 2	0.25	
	5.25	0.6	10 X 8		3	4 X 4	0.4		6 X 3 X 2	0.3	
	5.5	0.7	11 X 9		4	4.5 X 4.5	0.5		ASSCHER	4	0.3
	5.75	0.8	12 X 10	5	5 X 5	0.75	4.5	0.5			
6	0.9	MARQUISE	4 X 2	0.1	5.5 X 5.5	1	5	0.6			
6.25	1		5 X 2.5	0.15	6 X 6	1.25	5.5	0.8			
6.5	1.25		5 X 3	0.18	6.5 X 6.5	1.5	6	1.2			
7	1.5		6 X 3	0.25	7 X 7	2	6.5	1.5			
7.5	1.75		7 X 3.5	0.35	8 X 8	3	7	2			
8	2		8 X 4	0.5	SQ PRINCESS w/blunt corners	4	0.4	7.5		2.25	
9	3		10 X 5	1		4.5	0.5	8		2.5	
10	4		11 X 5.5	1.5		5	0.7	8.5		3	
SQ RADIANT	4		0.25	12 X 6		2	5.5	1	9	4	
	4.5		0.5	13 X 6.5		2.5	6	1.2	9.5	4.5	
	5	0.75	14 X 7	3		6.5	1.5	10	5.5		
	5.5	1	15 X 7.5	3.5		7	2	11	6		
	6	1.25	16 X 8	4		7.5	2.25	12	8		
	6.5	1.5	SQ CUSHION	4		0.25	8	2.5	PEAR	5 X 3	0.25
	7	2		4.5		0.5	8.5	3		6 X 4	0.5
	7.5	2.5		5	0.6	9	3.75	7 X 5		0.75	
	8	3		5.5	0.9	9.5	4.5	8 X 5		1	
	8.5	3.5		6	1	10	5.5	9 X 6		1.5	
	9	4		6.5	1.5	HEART	4 X 4	0.25		10 X 7	2
	9.5	4.75		7	2		5 X 5	0.5		12 X 8	3
10	5.5	7.5		2.25	6 X 6		1	CUSHION		5 X 5	0.75
10.5	6	8		2.5	6.5 X 6.5		1.25			6 X 6	1
11	7	8.5		3	7 X 7		1.5			7 X 7	1.75
12	9	9	3.5	8 X 8	2		8 X 8		2.5		
		9.5	4	9 X 9	3		9 X 9		3.25		
		10	5.5	10 X 10	4		10 X 10		4		
		10.5	6	11 X 11	5		11 X 11		4.75		
		11	6.5								
		12	8								

ABSOLUTE™ SIMULATED DIAMOND STANDARDS

Absolute™ Jewelry (including sub-categories: Victoria Wieck, Xavier, Jean Dousset, etc.)

The use of the Absolute™ name describes all product simulating genuine diamond colors.

Absolute™ jewelry must be free from all imperfections, chips, nicks, and abrasions.

Faceting of Absolute™ jewelry must be crisp, symmetrical and match in size and placement to genuine diamonds.

Absolute™ stones must have superior polish, including polishing of stone girdles

Required Stone Suppliers

- All Absolute™ 1mm-8mm clear, round, machine-cut CZ should be sourced from Signity/Swarovski Co. (800-444-0480), HSN's preferred resource, at the HSN negotiated price.
- All other sizes, colors, and shapes for Absolute™ may be sourced through Signity/Swarovski Co. (800-444-0480), Preciosa <http://www.preciosa.com/en/company/contact-us.html>, or Elite Group (212-827-0577).
- Requests to source a CZ stone for Absolute™ outside of the three mentioned approved resources MUST be approved in advance by HSN Merchandising and QA.
 - Straight and tapered baguettes, unique shapes/sizes and/or colored CZ may be purchased from other resources (if not available from the approved suppliers) provided that Absolute™ quality standards are maintained.
 - Inferior quality CZ will not be accepted

Declaration of CZ Weight

- Absolute™ uses "Diamond Equivalent" to describe stone weight, rather than actual CZ weight.
- HSN Partners should determine the diamond equivalent weight by using the [conversion chart](#), and enter "DE weight" in the stone section of the product specification sheet. Stone weight tolerance for Absolute™ is not applicable.
- Please contact HSN QA for stone shapes/sizes not found on the [conversion chart](#).
- Colored stones should be expressed as Diamond Equivalent ONLY if they are diamond look-alike colors, i.e. pink, canary, brown, black. DE weights for these should come from the same [conversion chart](#) used for clear.
 - Other colors, such as red (ruby), blue (sapphire), green (emerald), purple (Tanzanite) should be expressed as "Gemstone Equivalent", or GE. Please contact your QA evaluator for conversion information.

Facet Arrangement of a Standard Round Brilliant

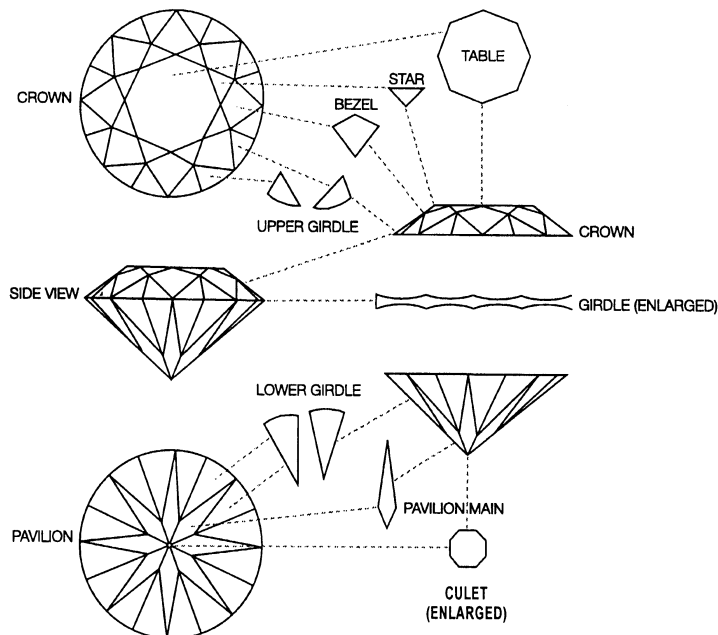

DIAMOND STANDARDS

All diamonds must match in cut, color, clarity, and size, as called for in the design.

Glue/adhesives used for the purpose of securing stones is **not** permitted.

Please see Appendix C – Glossary of Jewelry Terms, [Diamonds](#), or Gemological Institute of America

<http://www.gia.edu/diamond> for more information.

Cut

- Full cuts and single cuts cannot be mixed within a piece, or within a matched set.
- Adjacent set baguettes must be proportionally cut and evenly spaced and set.
- At the buyer's discretion, in some instances diamonds may be used that have less than 17 facets. In such cases, the diamonds must be referred to as "rose cut diamonds". This applies only to certain product categories, and must have the buyer's approval.
- Fancy shapes: length: width ratio must profile pleasing shape. Extremely pointed marquises, high shoulders, fat or straight wings, squat or squarish ovals/pears are unacceptable.

Color

- Diamond color will be determined by spec sheet and appraisals and verified by GIA approved color grading scale.
- Unless otherwise specified, H - I color, I1 clarity will be used in the Diamond Program. Please refer to GIA diamond grading qualities and descriptions/definitions.

Clarity

- Any stone will be rejected if determined to be structurally unsound due to the nature and location of fractures or inclusions.
- Diamond clarity will be determined by specification sheet and appraisals and verified by GIA approved clarity grading scale.

Carat Weight

- If diamond weight is stated as decimal parts of a carat (0.47), the stated figure should be accurate to the last decimal place (could represent weight between .465-.474) rounded to 0.47 carats. Weights will be verified.
- If diamond weight is described in fractions, the fraction may represent a range of weights. If you use the fractional method, you must disclose that the diamond weight is not exact and the reasonable range of weight for each fraction.

Unless otherwise specified, stones will be **rejected** for the following:

- Small chips, opens, or cavities on the table surface.
- Feathers or inclusions that break the table surface.
- Inclusions, feathers, chips, cavities, or breaks that threaten the durability or structure of the stone.
- Severely fluorescent, oily, chalky, cloudy, milky, opaque, or dead stones.
- Burned facets or abrasions.
- Severely out of round or disproportionate fancy shapes.
- Overly large culets, excessively thick and/or thin girdles.
- Synthetic, treated, or enhanced (lasered or fracture filled) stones.

PEARL STANDARDS

Pearl Standards

The following seven (7) factors are used in the quality grading of pearls:

1. **Size**
2. **Shape**
3. **Color**
4. **Luster**
5. **Surface quality**
6. **Nacre quality**
7. **Matching**

- All treatments must be disclosed within the jewelry product specification sheet.
- Pearls must match in size, body color, overtone, and luster.
- Pearls must have a smooth, iridescent finish with no evidence of peeling.
- Individual spherical pearls or pearl strands are to be measured perpendicular to the drill hole, stated in half-millimeter size ranges (i.e. 6.0 - 6.5mm). All must fall into the size range stated.
- Individual baroque and mabe pearls 8mm or larger can have ±0.5mm tolerance from the stated millimeter size. Pearls over 10mm are allowed a ± 1mm tolerance.
- Pearl strands with round pearls 8mm or greater in diameter will have an overall length tolerance of -¼ to +½ inch. Use of ¾ pearls is acceptable, provided they are set in such a manner so that the cut section is not exposed.
- Blinking (being able to see the mother-of-pearl nucleus due to thin nacre) should not be excessive or detract from the appeal of the item.
- Blisters on pearls that open up and expose the nucleus are unacceptable.
- Circlé pearls (indentations or ridges circling the perimeter) must contain one or more grooved or ridged rings on the surface of the pearl.
- Color ranges for dyed black pearls may be determined acceptable based on established color ranges. It is suggested that loose pearls, representing the range to be used, be submitted prior to the manufacturing of the product.
- Color ranges for black Tahitian pearls may be determined acceptable based on established color ranges. Ranges must stay within one color series (i.e. grays, peacocks, greens, blues, and eggplant).
- Dyed pearls will be subjected to colorfastness testing as described in the [Quality and Performance Standards](#) section of this document
- Minimum knotting requirement for all pearl strands is one knot for every quarter section of length (4 knots per strand). Knotting is preferred between each pearl on Akoya, Tahitian, South Sea, and spherical freshwater strands. Pearls must be tied off at the clasp by going back through a minimum of three pearls.
- Pearls that are not strung must be ½ drilled and seated on a cup and peg that is proportionate to the pearl size. The use of glue only (without cup and peg) to hold a pearl in the mounting is unacceptable and will be rejected.
- Wire wrapping must be straight and neat. Ends must be tucked in.
- HSN Akoya pearls are graded according to the standards below:



HSN Akoya Pearl Grading Chart			
	Grade A	Grade AA	Grade AAA
Luster	medium to good	good to high	very high to excellent
Nacre	medium	medium to thick	thick to very thick
Blemishes	lightly blemished	lightly blemished to slightly blemished	very slightly blemished to unblemished
Shape	near round to mostly round	mostly round to round	round
Color	white medium or cream medium body color with pink, gray, green overtone	white or light cream body color with pink, gray, green overtone	white body color with light pink, gray overtones
Matching	good	good to very good	very good to excellent

RING STANDARDS

Stamping

- Trademark/fineness/country of origin should be stamped on the upper inside shank or shoulder away from the sizing area, as applicable.

Sizing

Ring Mandrels

- To ensure consistency in sizing, HSN requires all Partners to purchase and use calibrated mandrels available from Romanoff Supply, 631-842-2400 item number M3-201-R.
- A mandrel with a variance of +/- 1/16 size (+/- 0.002" in diameter) from the U.S. standards is considered acceptable.

How to Measure

- The ring should be dropped on the mandrel, allowing the ring to center itself with minor pressure. The ring should not be forced onto the mandrel.
- Rings should not be stretched to size. Sizing should be done in the models.
- Ring sizes are determined by the leading edge of the shank. The leading edge is the "lower" edge or the edge that falls first onto the mandrel.
- Some allowances can be made for extra wide ring shanks (above 7mm wide), large open-backed rings, rolling rings, bypass, or unusual geometrically designed shanks. Contact your evaluator in these cases to determine the proper method to measure.

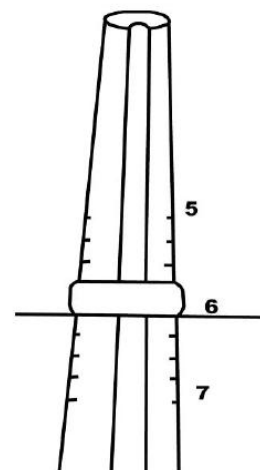

Ring Sizing Tolerance

- Sizing tolerance for rings is -0 to +1/4 size.

Construction/Quality

- Shanks in all ring sizes must be thick enough to withstand the "pinch test"—a moderate amount of pressure applied by human fingers to the shank side and/or bottom.
- Gold rings have a suggested minimum thickness of .8mm thick/1.4mm wide, but must be appropriate to the styling of the piece.
- Sterling silver ring shanks must have a minimum thickness of 1mm.
- Larger sizes may require thicker shanks.
- Ring shanks must also be consistent across finger sizes.
- There should be no solder seams in production.

RING STANDARDS CONTINUED

Construction/Quality (continued)

The edges must be smooth

The inner circumference of the shank must be round

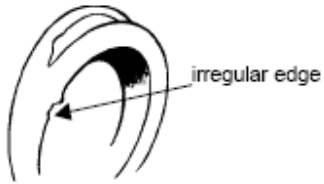

incorrect



correct

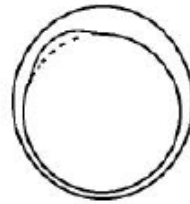

incorrect

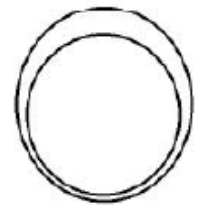

correct

The culet must never extend below the finger rest of a ring.

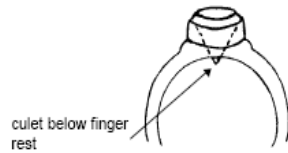

incorrect

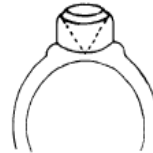

correct

Heads and settings must be in alignment when viewed from the top, side and edge.

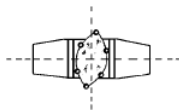

incorrect

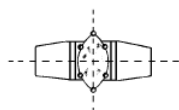

correct



incorrect



correct

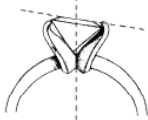

incorrect

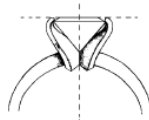

correct



incorrect

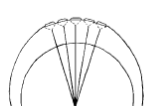

correct

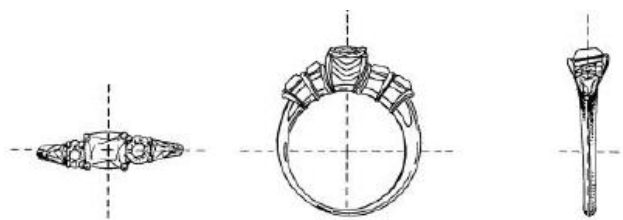

Top view

incorrect

Side view

incorrect

Edge view

incorrect

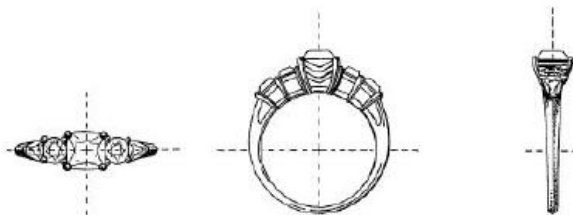

Top view

correct

Side view

correct

Edge view

correct

EARRING STANDARDS

Stamping

- Each half of earring pair must be stamped with fineness, trademark and country of origin, as applicable.
- Clutch backs must also be stamped with fineness and trademark. Country of origin is not required.

Post/Wire Sizing

- HSN requires the following minimum post/wire measurements; useable length can be considered as the length of the post extending beyond the back plane of the earring.

	Post Thickness	Usable Length	Ear Wires on Hoops	Clutch Backs
Gold	0.67 mm – 0.76 mm 670 μm - μm (0.0265 in – 0.030 in)	9.5 mm (0.375 in)	0.75 mm – 1.0 mm 750 μm – 1,000 μm (0.029 in – 0.040 in)	≥4.5 mm ≥0.177 in
Silver and Other Metals	0.73 mm – 0.81 mm 730 μm - 810 μm (0.029 in – 0.0321 in)	9.5 mm (0.375 in)	0.75 mm – 1.0 mm 750 μm – 1,000 μm (0.029 in – 0.040 in)	≥4.5 mm ≥0.177 in

Construction/Quality

- Each earring pair should match. Asymmetrical designs should have right and left earrings.
- Exposed culets may be allowed depending on the design.
- Earring posts must be strong enough to withstand normal use. Ends should be rounded and smooth.
- Earring posts should be made from the same precious metal type as the earring.
- Earring posts/wires on alternative metals must be plated with 14K or higher over .925 sterling or hypo-allergenic post or wires, as applicable to product category, to match metal color.
- Earring posts and earring wires on fashion jewelry must be made from hypo-allergenic materials or plated to prevent allergic skin reaction.
- Comfort pads may be required for clip-on earring styles.
- Hoop earrings should have a gap wide enough to fit over most ear lobes with enough room to allow the hoop to swing freely. HSN recommends a minimum gap of at least 8mm, not counting joint and catch findings.
- Ear wires on hoops should be strong enough to be able to function with the catch, but not so thick that they are difficult to wear. The ends should be rounded and smooth.

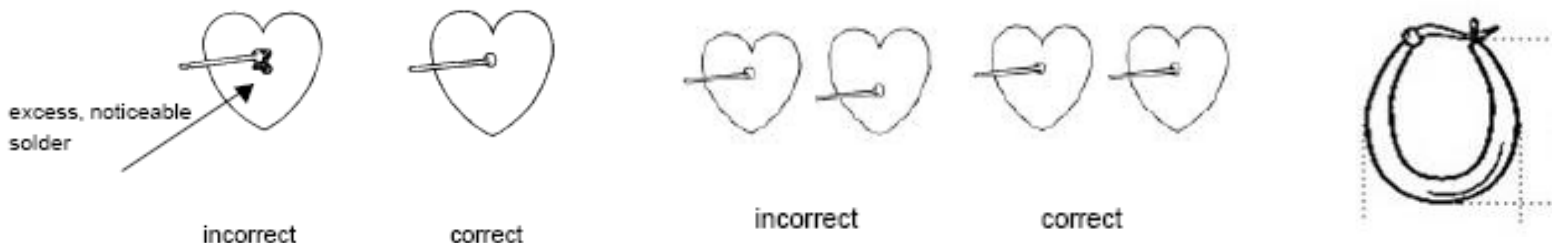

BRACELET, NECKLACE AND PENDANT STANDARDS

Stamping

- Bracelets, Necklaces and Pendants must be stamped with fineness, trademark and country of origin, as applicable.
- If the pendant is removable from the chain, both pendant and chain must have trademark/fineness/country of origin stamps

Sizing Tolerance

- Length tolerance for necklaces and bracelets is -0 to +1/4".
- HSN will allow a tolerance of -0 to +1/2" for necklaces composed of irregularly shaped stones and beads. Bracelets will maintain the -0 to +1/4" tolerance. Please consult with your evaluator for circumstances that may require additional (+) tolerance.
- Measurement is based on the "useable length" of the item. If the clasp does not contribute to the useable length, it is not included in the measurement.
- For items sold with "extenders," the tolerance applies only to the necklace or bracelet itself. There is no tolerance for the extender.

Bangle/Cuff Bracelet Sizing Tolerance

- Inside circumference tolerance for bangle bracelets is -0 to +1/8".
- Measure using the rolled paper method as defined in the [Product Measurement](#) section of this document

Advertised Size Term	Oval or Round Bangle Interior Circumference <u>With Hinges</u>	Oval or Round Bangle Interior Circumference <u>Without Hinges</u>
Petite	6 1/4" (158.75 mm)	7 1/4" (184.15 mm)
Small	6 3/4" (171.45 mm)	7 3/4" (196.85 mm)
Medium (Average)	7 1/4" (184.15 mm)	8 1/4" (209.55 mm)
Large	7 3/4" (196.85 mm)	8 3/4" (222.25 mm)
Small/Medium	7" (177.80 mm)	8" (203.20 mm)
Medium/Large	7 1/2" (190.5 mm)	8 1/2" (215.90 mm)

Construction/Quality

- Pendant bails must be large enough to allow the pendant to swing freely on the chain. For pendants sold without a chain, bails must be large enough to accommodate a normal variety of customer chains.
- Necklaces/pendants constructed with colored string, dyed cord, rubber cord, or stretchable elastic must be colorfast.
- All parts must be symmetrical, balanced and aligned, from front, reverse, and edge views.
- Stone culets must not extend below the bottom edge of the setting.

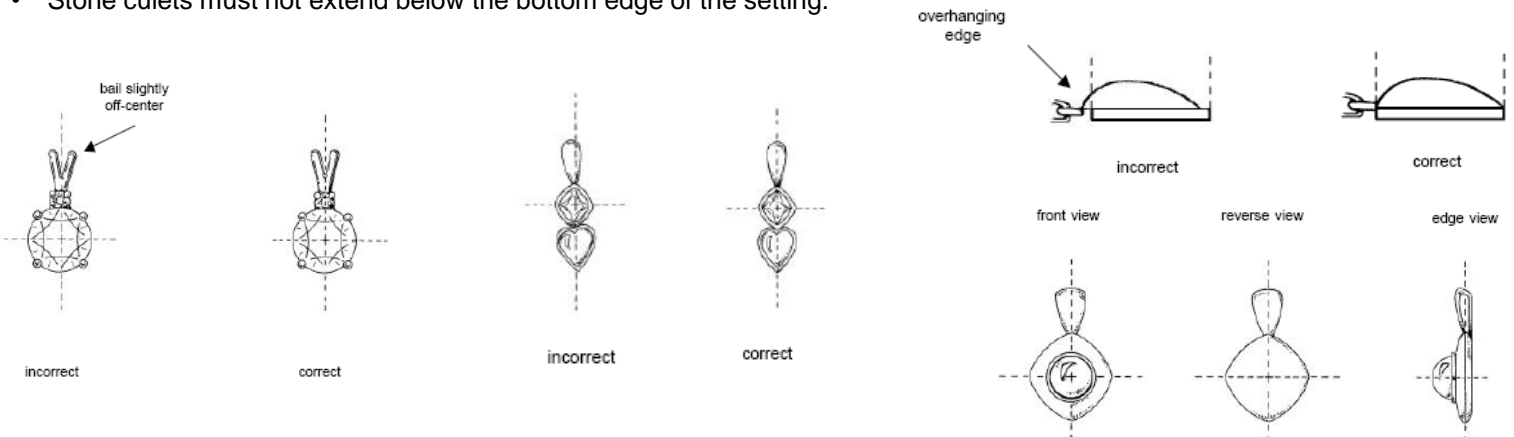

BRACELET, NECKLACE AND PENDANT SPECIFIC CONTINUED

Construction/Quality (continued)

Jump rings on all products must be fully closed.
 Jump rings on karat gold or sterling silver product must be soldered closed.

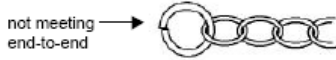

incorrect



correct: with soldering



correct: no soldering

Spring ring must be proportionate, and the wire and tube must be aligned.

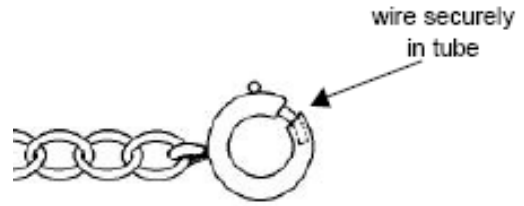

correct

Box or barrel type clasps must have at least one figure-8 safety clasp, which must be correctly aligned.
 If design will not permit, please contact QA evaluator.

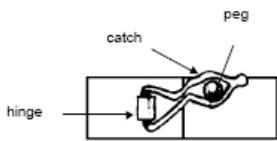

incorrect

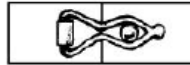

correct

Box or Hidden clasps: the tongue must fit securely in the box of the clasp, and not come out without firmly depressing the plunger.

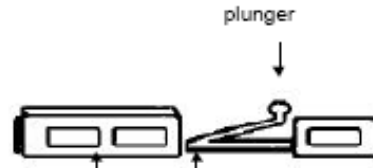

box tongue

Lobster claw catches must be proportionate and the tongue and claw aligned with no gap.

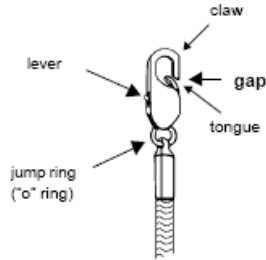

incorrect

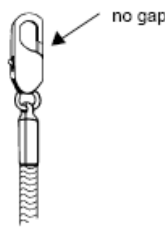

correct

WATCH STANDARDS

Stamping – Case, Band, and Movement

- Trademark – name/stamps required on dial or case back.
- Quality hallmarks required on case back and band, if applicable.
- Precious metal - fineness and registered trademark.
- Country of origin
 - Case and band: HSN requires that the case and band be stamped with the country of origin/assembly. The marks should be as permanent as possible, hang tags are only allowed on an exception basis (the case stamp will cover the band if it is the same country of origin).
 - No factory price tags are allowed.
 - Movement: the country of origin for the movement must be permanently marked. It may be printed in very small letters at the bottom of the face at six o'clock, on the back or inside on the movement.
- Other disclosures may be printed inside the watch.
- Genuine leather bands must be hot stamped “GENUINE LEATHER.”
- Hang tags must be approved by HSN QA.

Case Measurements and Sizing Tolerance

- Length: including lugs.
- Width: including crown.
- Height: measure from back of case to top of crystal.

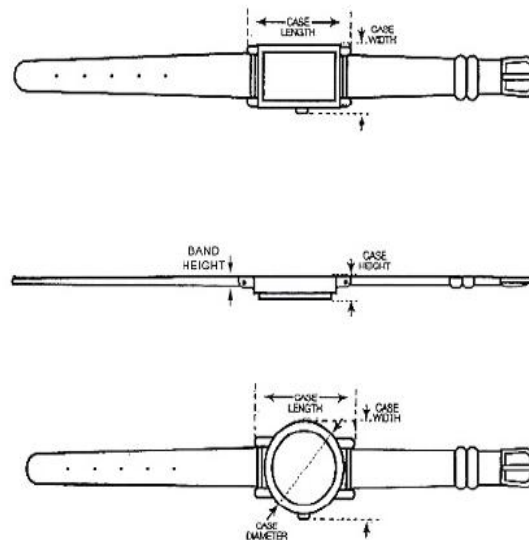
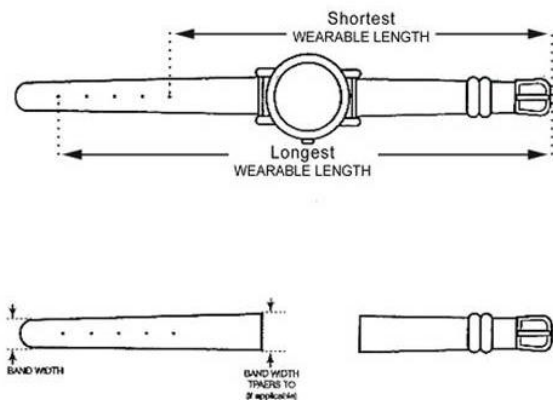

Construction/Quality

General

- Watch operates as intended, including all special features (alarm, chronograph, date, clasps, etc.) and sets per the instructions.
 - Crown must be easily accessible, and pull out/push in for adjustments without becoming detached.
 - Screw-in crowns should be threaded properly to operate with ease.
- Lugs should be drilled deep enough to accommodate the strap pins; the pins must be the appropriate length.
- Accessories must assemble, fit and operate as intended (interchangeable bezels, watch fob/chain, etc)
- Dials must be oriented correctly
- Holes in band/strap must be evenly spaced and punched all the way through.
- Leather and fabric materials must be colorfast.
- All gemstones and their settings must meet the requirements contained within the [Construction Standards](#) and [Gemstone & CZ Standards](#) sections of this document

WATCH STANDARDS CONTINUED

Water Resistant/Shock Resistant Ratings Requirements

- If shock-resistant, the word “SHOCK-RESISTANT” must be marked on the watch.
- Documentation confirming the product successfully withstands ISO 1413 Shock Resistant Standards is required.
- If water-resistant, the word “WATER-RESISTANT” must be marked on the watch, stamped on case back or marked on dial with depth (not required for nationally recognized brands).
- Documentation confirming the product successfully withstands ISO 6425 Water Resistant Watch Standards is required.
- Inclusion of a water-resistant rating and depth chart is recommended.
- Use of the term “water-proof” is not acceptable.

Water resistance rating	Suitability
No indication	Not resistant to splashing or other accidental contact with moisture of any kind.
Water Resistant or 30 m	Suitable for everyday use. Splash/rain resistant. NOT suitable for swimming, snorkeling, water related work and fishing.
Water Resistant 50 m	Suitable for swimming, white water rafting, non-snorkeling water related work, and fishing.
Water Resistant 100 m	Suitable for recreational surfing, swimming, snorkeling, sailing and water sports.
Water Resistant 200 m	Suitable for professional marine activity and serious surface water sports.
Diver's 100 m	Minimum ISO standard (ISO 6425) for scuba diving at depths NOT suitable for saturation diving.
Diver's 200 m or 300 m	Suitable for scuba diving at depths NOT suitable for saturation diving.

ATM		
This value is intended to represent the mean atmospheric pressure at mean sea level at the latitude of Paris, France, and as a practical matter, truly reflects the mean sea level pressure for many of the industrialized nations (those with latitudes similar to Paris).		
DEPTH CONVERSION		
FEET	ATM	METERS
100	3	30
160	5	50
300	10	100
660	20	200
1000	30	300
1650	50	500

Instructions/Warranties

- Instructions for use (how to set/adjust/wear) and care of the watch must be included.
- All products offering a warranty must include a warranty card/document identifying the length of warranty period, limitations, instructions where to send and cost for service, approximate return time, etc. as shown in the below example

<p>MANUFACTURER’S LIMITED WARRANTY</p> <p>“NAME OF COMPANY” warrants the “NAME OF ITEM” shall be free of defects in material and workmanship for a period of “LENGTH OF WARRANTY PERIOD” from date of purchase.</p> <p>The warranty does not apply to “PARTS OF THE ITEM NOT COVERED BY THE WARRANTY,” normal wear and tear or abuse or if the product has been altered in any way.</p> <p>In the event of a defect in material or workmanship within the warranty period, send the item postage prepaid and a check in the amount of “\$\$\$” to cover return shipping and handling to:</p> <p>NAME OF COMPANY STREET CITY, STATE, ZIP CODE</p>
<p>The item will be repaired or replaced at our discretion and returned within “TIME PERIOD IN NUMBER OF WEEKS” of receipt. You can contact the manufacturer at “1-800-000-0000” for information on the status of your item.</p> <p>Any unauthorized service of the item will void the warranty. No additional charge will be necessary unless additional servicing for reason beyond our control or as a result of accident, misuse, neglect or other reason outside the scope of the warranty. Customers will be notified of this charge, should it exist, prior to servicing.</p> <p>This warranty gives you specific rights, and you may have other rights, which vary from state to state.</p>

PACKAGING

The integrity of the container and packaging of the product are the partner's responsibility. The partner must ensure that the product packaging can withstand the shipping environment.

HSN QA evaluators may suggest certain packaging, based on their experience. However, it is the responsibility of the partner to ensure that jewelry products are packaged so that they do not become damaged or soiled during transport. The partner should always perform their own drop, vibration or other testing to ensure that the packaging is resistant to soiling or other damage.

HSN has established Brand Packaging Standards for Jewelry products that must be followed by our partners. The detailed brand packaging requirements can be found in the HSN Partner Supply Chain Requirements Manual – Brand Packaging https://view.hsn.net/WebDocuments/documents/6a-Brand%20Packaging_edited_2.pdf

Partners are not, under any circumstances, permitted to substitute boxes or packaging for any item(s) unless approved by HSN Merchandising and QA.

Additional information on packaging integrity can be found in the HSN Partner Supply Chain Requirements Manual – Quality Assurance <https://view.hsn.net/WebDocuments/documents/4-Quality%20Assurance.pdf>

Partners shipping product on Import PO's should refer to the Imports Bulk Packaging Standards instructions found at <https://view.hsn.net/WebDocuments/documents/7b-Import%20Shipping.pdf>

Other Packaging Considerations

- The cost of boxing, sleeves, and inserts is the partner's responsibility.
- Specific packaging will be communicated to the partner via the "Approved Pack Recipe" in the Evaluation Report.
- It is the partner's responsibility to test the product in the boxing and communicate any changes to the box recipe necessary to protect the product in transit.
- Items must be completely dry prior to packaging.
- Gloves should be worn during handling and packaging, to provide final polish and insure that no fingerprints are on the product.
- HSN QA must approve specialty boxes and/or inserts not included in HSN's standard boxing program. In the event specialty boxing is used, the partner may be required to supply HSN with extra boxing materials for use in our warehouse.
- Leather and rubber cord should be packaged separately from the item as it accelerates the tarnishing of the item if they are packaged together.
- All silver, plated silver (including Technibond® and vermeil), copper, bronze, alternative metals, and some stainless steel items must include anti-tarnish protection.
- Product that is plated with either gold, fine silver, or rhodium is still subject to tarnishing over time and must be packaged with anti-tarnish protection.

CLAIM SUBSTANTIATION

Background

Every objective product claim, whether express or implied, must be supported by evidence providing a reasonable basis for the claim. Objective evidence that supports claims about a product's performance, features, safety, effectiveness, or price is required to be included with the product specification sheet.

Objective Claims

All objective performance claims require competent and reliable scientific substantiation. Product performance claims must be adequately substantiated with standardized laboratory test data, studies, or other scientific evidence. Tabloid articles, magazines, newspaper articles, testimonials, and most Internet sources generally do not constitute reliable sources for substantiation.

Certified and Limited Edition Jewelry

- "Limited edition" merchandise must clearly state on the item or within each item's packaging the nature, extent or duration of the limited production (e.g., "limited to 5,000 units").
- If the merchandise is both numbered and limited (e.g., "#617/5,000"), each item must have a certificate of authenticity included within the packaging, and each certificate must correspond with the number on the item itself.
- Where the limited edition is associated with a place or event with historical or cultural significance (e.g. glass from the Sistine chapel), a certificate of authenticity needs to be included with the product given the unique source of the item/material.

Handmade Jewelry

- To be sold as "hand-fabricated" or "handmade", the item must be made entirely by hand or with hand tools; it cannot be made with pre-made findings. The entire formation, from raw materials to finishing, must be done manually, using hand labor and manually-controlled methods which permit the maker to control and vary the construction, shape, design, and finish of each part of each individual product.
- Items hand-fabricated with machine-made findings may be described as "hand-assembled" or "handcrafted."
- Terms such as "hand-polished", "hand-finished" or "hand-engraved" can be used only when the entire process was done manually, allowing for variations in the effects created on each item.

Licensed Jewelry

HSN vendor partners submitting licensed items (e.g. MLB, NFL, Disney) to HSN QA must certify that they are valid licensed sellers of the item(s).

Acceptable certification from the HSN vendor partner includes:

- An attestation from the licensor that certifies that the HSN vendor of record holds a valid licensing agreement.
 - Specifically state the licensee and the type(s) of products they are licensed to produce and/or sell.
 - State the valid start and end date of the current licensing agreement.
 - The licensor's name, title, and contact information must be included.
- A copy of the official licensing agreement issued to the vendor partner by the licensor (example: MLB, NFL, Disney).
 - A redacted licensing agreement may be submitted.

NOTE: *this attestation will be separate from music releases allowing music to be played during on air presentation.*

Crystals from Swarovski ®

Items to be advertised as containing Swarovski crystals must be verified and approved by Swarovski.

- Partner must upload the Swarovski issued letter of authorization into the Product Specification Sheet
 - For details on the authorization process, please contact Swarovski at <http://professional.swarovski.com>.
- To be advertised as adorned with or embellished with "Crystals from Swarovski ®" the following conditions apply.
 - 100% of the crystals are Swarovski crystals.
 - When there is a mix of crystals and precious/semi-precious gemstones, ALL crystals MUST be Swarovski.

PRODUCTION INSPECTION

Pre-Shipment Inspection

Production inspections can occur on-site at the partner's facility (pre-shipment inspection) or at the HSN Fulfillment Center (post-shipment inspection). A Field Inspector will selectively travel to manufacturers' facilities to conduct on-site quality assurance inspections. Our QA On-Site Inspection Program has had a tremendous impact on improving the quality of the products we sell. Designed to facilitate early detection of quality issues upstream in the factories, the program has enabled the proactive management of product failures before the order is shipped to HSN, or worse, our customers. Information and instructions for on-site inspection scheduling can be found on the Partner Portal <https://view.hsn.net/Documents/Documents.aspx>

On-Site inspections are initiated by one or more of the following criteria

- Products scheduled to be an HSN "Today's Special" (TS -the primary featured item of the day)
- Key Items as defined by merchandising; this typically entails item orders valued over \$75,000
- Products purchased under Import and/or Letter of Credit (LOC) terms
- Products from Partners who have been identified by QA as requiring close quality management (Quality Focus)
- Products from new Partners preparing for their premiere show
- Key brand or product launches
- Additionally, QA initiates on-site inspections when customers voice recurring concerns with a product's quality

On-Site field Inspection requirements for Jewelry/Watch Products

- Final Inspections must be 100% produced with at least 5% packaged, labeled and ready for inspection. All applicable barcode tags and inserts must be available for review.
- In addition to the final inspection, all Today's Special (TS) items are required to have in-process inspection conducted when each colorway is at least 10% but no more than 20% produced.
- Upsell items to the TS may also be reviewed at the in-process inspection.

On-site field inspection is based on

- ANSI/AS QC Z1.4-2003, -General Level 1 Inspection Level –Double Sampling Plan (4.0 AQL)
- HSN QA may choose tightened inspection levels or deviate from this plan at its own discretion.

QA master samples may be sent to the partner's facility prior to the on-site inspection. Should you receive a package addressed to the on-site Field Inspector, **do not open** this package. If the package is opened, HSN reserves the right to cancel the on-site inspection and re-approve the samples to be used as master samples.

Please provide the Field Inspector with the following items to conduct the inspection

- A printed copy of the most recent HSN PO for inspector to verify quantity and item numbers.
- [HSN-approved mandrel](#) for inspector to use.
- A calibrated diamond carat scale and/or gram scale large with readability and accuracy into the hundredths (0.00).

PRODUCTION INSPECTION CONTINUED**Pre-Shipment Inspection (continued)**On-site field inspections - the onsite inspector will conduct the following:

- Physical count of the production for comparison against the purchase order quantity.
- Visual comparison of the product against the product specifications and/or master sample to ensure consistency
- Visual evaluation of quality (workmanship, construction, polishing, etc.)
 - Special attention will be given to issues/observations documented during the QA sample evaluation.
- All inspections are conducted with the unaided eye at a “bent elbow” distance (approx. 6” – 12” from the eyes) to identify defects that are seen without magnification.
- Inspectors do not use magnification to detect defects, however, they may use a 10X jeweler’s loupe or 2X to 5X glasses to obtain a clearer view of an eye-visible feature such as a hallmark, or to better understand the nature of a defect.
- Measurement of the product against the approved specifications and/or master sample.
- Measurement of the gram weight (Karat gold or sterling silver items), carat weight (gemstone items)
 - Stone breakout to verify carat weight (gemstone items)
 - Inspector will breakout stones, or request the partner breakout stones.
 - Loose stones provided by the partner are not acceptable for carat weight verification.
 - Stone breakouts may be sent to HSN QA in St. Petersburg for laboratory testing.
- Samples may be pulled for plating thickness testing, gemstone verification, or other testing as required.

After the Inspection

- Defective merchandise identified during an inspection visit may be reworked, sorted or rejected.
- Reduced quantities must receive approval of merchandising department prior to acceptance so that the PO quantity can be adjusted to reflect the new accepted quantity.
- Master samples must be returned to HSN, where they will be archived for future reference.
- At the conclusion of each onsite inspection, the Field Inspector will complete a QA Field Inspection Report explaining the results of the inspection, review it with the facility contact and obtain a signature from the representative confirming review of the inspection results.

The Onsite Inspection Preparation Letter provides details on preparing for the inspection process, including requirements for scheduling changes or cancellations. Failure to provide at least 2 business days notice for cancellations/date changes may result in fees for missed inspections or late cancellations.

https://view.hsn.net/WebDocuments/documents/02_Jewelry_OnSiteInspectionPrepLetter_635380737320031022.docx

NOTE: If the product will not be ready at the scheduled time of inspection, the partner must contact the Inspection Service Provider, Onsite Inspection Coordinator and/or the Onsite Inspection Manager at least two business days prior to the scheduled inspection. Partners may incur fees for missed, postponed, cancelled, or failed inspections.

Additional information regarding the onsite inspection program, inspection costs and penalty fees can be found in the HSN Partner Supply Chain Requirements Manual

<https://view.hsn.net/WebDocuments/documents/4-Quality%20Assurance.pdf>

https://view.hsn.net/WebDocuments/documents/01_OnSiteWelcomeLetter.pdf

PRODUCTION INSPECTION CONTINUED

Post-Shipment Inspection

Just like the On-Site inspection, the HSN Fulfillment QA (FQA) inspection is part of the Finished Product Inspection process and acts as a follow-up to the Corporate QA (CQA) Evaluator's Initial Product Inspection. This means that our FQA Inspectors, like the On-Site Inspector, must:

- Assess the product's conformance to Initial Product Evaluation
- Evaluate the presentation and functionality of the product labeling and packaging
- Identify any potential issues before the item ships to the customer

FQA Inspectors conduct their inspections solely from their respective Fulfillment Centers, pulling random product samples from the same stock of items from which the customer receives her items. This affords HSN a prime opportunity to view the finished product, packaging and all, in the same state as the customer receives it.

FQA inspectors will conduct a visual comparison against the product specifications to ensure consistency. Comments, concerns, and contingencies noted during the sample evaluation will be given special attention during the final inspection.

Incoming merchandise will be inspected according to ANSI ASQ Z1.4, Inspection Level 1, (Double Sampling) plan. HSN QA may choose tightened inspection levels or deviate from this plan at its own discretion.

Partners may be billed a chargeback fee whenever the inspected merchandise does not conform to the PO, HSN QA evaluation samples, or *Product Specification Sheet*, or is not compliant with the requirements listed in this manual or the "HSN Supply Chain Requirements Manual". The chargeback fees are set forth in the current *Product Fee Schedule* found in your HSN Partner Supply Chain Manual - Compliance.

<https://view.hsn.net/WebDocuments/documents/8-Compliance.pdf>

PRODUCTION INSPECTION CONTINUED

Jewelry/Watch Onsite Inspection Sampling Plan

The chart below is based on ANSI/ASQ Z1.4-2003, Normal Inspection, Double Sampling Plan.

The default sampling level is General Level I and 4.0 AQL.

Rarities by Carol Brodie product (HSN Category #71) is subject to a General Level II sampling level and 1.5 AQL.

lot size		normal (inspection level I)		Rarities by Carol Brodie Brand Product (inspection level II)	
		sample size	4.0 AQL (accept/reject)	sample size	1.5 AQL (accept/reject)
2 to 25	1st	3	0/1	3	0/1
	2nd	100%	NA	100%	NA
26 to 50	1st	3	0/2	5	0/2
	2nd	3	1/2	5	1/2
51 to 90	1st	3	0/2	8	0/2
	2nd	3	1/2	8	1/2
91 to 150	1st	5	0/2	13	0/2
	2nd	5	1/2	13	1/2
151 to 280	1st	8	0/2	20	0/2
	2nd	8	1/2	20	1/2
281 to 500	1st	13	0/3	32	0/3
	2nd	13	3/4	32	3/4
501 to 1,200	1st	20	1/4	50	1/4
	2nd	20	4/5	50	4/5
1,201 to 3,200	1st	32	2/5	80	2/5
	2nd	32	6/7	80	6/7
3,201 to 10,000	1st	50	3/7	125	3/7
	2nd	50	8/9	125	8/9
10,001 to 35,000	1st	80	5/9	200	5/9
	2nd	80	12/13	200	12/13
35,0001 to 150,000	1st	125	7/11	315	7/11
	2nd	125	18/19	315	18/19

COMPLIANCE: CALIFORNIA PROPOSITION 65

What is California Proposition 65?

Proposition 65 (Prop 65) is a law approved by California voters in a referendum in 1986. It requires the state to keep a list of chemicals that cause cancer or reproductive toxicity. If a product contains a chemical on the list, a Prop 65 testing report must be provided. You can access the list of 800-plus chemicals on the California Office of Environmental Health Hazard Assessment website at http://www.oehha.ca.gov/prop65/prop65_list/Newlist.html. Lead, phthalates and other common chemicals are on the Proposition 65 list.

All products manufactured, distributed or sold in California must comply with the exposure and/or labeling requirements specified in Proposition 65. If a product contains a listed substance that will release from the product over time and in excess of the Proposition 65 limits, specified warning statements must appear on or near the product at the time of purchase.

Covered Products

HSN Partners supplying any of the products listed below under Proposition 65, must ensure that all items comply with the limits set forth. It is your responsibility to provide to HSN QA approved third-party laboratory reports with each item submission. This requirement applies to normal as well as value-added and GWP items.

Apparel	Cosmetic & Toiletry Bags	Footwear	Jewelry	Wallets
Belts	Electronics & Mobile Device Cases	Gloves	Key Chains	Watches
Ceramic Tableware	Eyeglass Cases	Hats	Scarves	
Clutches	Fashion Accessories	Handbags	Totes	

See California Proposition 65 Requirements document on the Partner Portal:

https://view.hsn.net/WebDocuments/documents/01_Prop65Guide.pdf

Certificate of Compliance with California’s Metal-Containing Jewelry Law

In addition to providing test reports evidencing compliance lead, cadmium and phthalates limits, all Jewelry and Watch items submitted to HSN QA must include a declaration of compliance with California law (written on the Partner’s company letterhead and uploaded to the Product Specification Sheet).

A sample of the required certificate of compliance language may be found on the HSN Partner Portal

<https://view.hsn.net/WebDocuments/documents/CA%20Metal%20Containing%20Jewelry%20Law%20Sample%20COC.doc>

NOTE: The Certificate of Compliance is NOT required for Jewelry made exclusively from Class 1 Materials (as defined under the law).

COMPLIANCE: CPSIA OF 2008

The Consumer Product Safety Improvement Act of 2008.

The Law now requires manufacturers and importers to certify that all products manufactured on or after November 12, 2008, are compliant with all applicable standards, rules and bans enforced by the Consumer Products Safety Commission (CPSC). Compliance shall be evident by a declaration or certificate of conformity. The Certificate of Compliance is required for applicable items. You can complete one and upload it to the Documents section of the product specification sheet. A blank Certificate of Conformity form will also be posted in the HSN Partner Portal under *For Your Information* and within the *QA/PI Standards Manuals* section.

https://view.hsn.net/WebDocuments/documents/03_CPSIA%20Certificate%20of%20Conformity.pdf

Additional information and frequently asked questions regarding the certificates are available on the CPSC's web site at <http://www.cpsc.gov/about/cpsia/cpsia.html>. Please work with your QA evaluator on the specific process for compliance. Be aware that the Certificate of Conformity is applicable to all products subject to the Federal Hazardous Substances Act (FHSA), the Flammable Fabrics Act (FFA), and the Consumer Product Safety Act (CPSA). Many different types of products are covered under FHSA, FFA, and CPSA.

Act Title	Section
Consumer Product Safety Act (CPSA)	16CFR1201 – Architectural Glazing Materials 16CFR1202 – Matchbooks 16CFR1203 – Bicycle Helmets 16CFR1204 – Antennas 16CFR1205 – Lawnmowers 16CFR1207 – Swimming Pool Slides 16CFR1209 – Interim Standard for Cellulose Insulation 16CFR1210 – Cigarette Lighters 16CFR1211 – Garage Door Openers 16CFR1212 – Multi-purpose Lighters 16CFR1213 – Entrapment in Bunk Beds 16CFR1301 – Refuse Bins 16CFR1302 – Flammable Contact Adhesives 16CFR1303 – Lead-Containing Paint 16CFR1304 – Consumer Patching Compounds 16CFR1305 – Artificial Emberizing Materials 16CFR1306 – Lawn Darts 16CFR1401 – Self-Pressurized Consumer Products 16CFR1402 – CB Base Station/TV Antennas 16CFR1404 – Cellulose Insulation 16CFR1406 – Coal and Wood Burning Appliances
Federal Hazardous Substances Act (FHSA)	16CFR1500 – Hazardous Substances / Toys and Other Articles Intended for Use by Children 16CFR1501 – Small Parts (Children <3 years) 16CFR1505 – Electrically Operated Toys and Other Electrically Operated Articles Intended for Use by Children 16CFR1507 – Fireworks Devices 16CFR1508/1509 – Baby Cribs 16CFR1510 – Rattles 16CFR1511 – Pacifiers 16CFR1512 – Bicycles 16CFR1513 – Bunk Beds
Flammable Fabrics Act (FFA)	16CFR1610 – Clothing Textiles / Wearing Apparel 16CFR1611 – Vinyl Plastic Film 16CFR1615/1616 – Children's Sleepwear 16CFR1630/1631 – Carpets and Rugs 16CFR1632 – Mattresses and Mattress Pads
Poison Prevention Packaging Act (PPPA)	16CFR1700
Refrigerator Safety Act (RSA)	16CFR1750

APPENDIX A – JEWELRY & WATCH QA STANDARDS CHECKLIST

<p>Sample Submission</p>	<ul style="list-style-type: none"> • Product specification sheet completed in the Partner Portal and submitted to the HSN Buyer • Print and affix sample label from the spec sheet to all samples prior to submittal • Sample sent to HSN QA must be representative of production <ul style="list-style-type: none"> • Made using actual materials and stones • Samples represent all color/metal/stone variants
<p>Packaging</p>	<ul style="list-style-type: none"> • Ensure the product packaging can withstand the shipping environment. Shipping hazards include but are not limited to shock, vibration, compression, heat and humidity • Protective packaging must be able to withstand ISTA (International Safe Transit Association) 2A and 3A test procedures • Polybags used to bundle sets must be a minimum of 1.0 mil thick; closure should be secured by bag tape, twist tie or heat-sealed • Polybags measuring 5” x 7” or larger require a printed child suffocation warning that should read: “Warning – To avoid danger of suffocation; keep away from babies and children. Do not use in cribs, beds or play pens. This bag is not a toy.” • Packaging presentation meets all HSN Brand Packaging requirements as published within the HSN Partner Supply Chain Requirements Manual – Brand Packaging https://view.hsn.net/WebDocuments/documents/6a-Brand%20Packaging.pdf • Boxes are clean and undamaged • Packaging consistent with the HSN QA “Approved Pack Recipe”, item is secure on pad or in box (won’t move in transit) and anti-tarnish tabs are enclosed (as applicable) • Warranty, Romance cards, etc, are enclosed (as applicable)
<p>Product Labeling / Stamping</p>	<ul style="list-style-type: none"> • Fineness/trademark/country of origin stamps present and legible • Country of origin stamp (if applicable) legible (hangtags must be approved by QA) • Genuine leather bands hot -stamped “Genuine Leather” (watches) • “Water Resistant” stamped on case back or marked on dial with the depth (as applicable for watches) • Labels are clean, readable and in the proper size for the box • Bar code labels can be scanned and are consistent with HSN barcode format requirements
<p>Measurement</p>	<ul style="list-style-type: none"> • Samples must measure within tolerance to the approved specs

APPENDIX A – JEWELRY & WATCH QA STANDARDS CHECKLIST CONTINUED

<p>Documentation & Compliance</p>	<p>All items and documentation must conform to current legal requirements and regulations, including but not limited to applicable federal and state laws, Federal Trade Commission (FTC) requirements and/or U.S. Custom requirements; it is the partner’s responsibility to understand and comply with these requirements</p> <ul style="list-style-type: none"> • Upload images of item and color range • Upload California Proposition 65 test reports and California Metal Containing Jewelry Law Certificate of Compliance to specification sheet • All objective and performance claims must be substantiated • Technical documentation and/or laboratory test data to substantiate objective and performance claims (for both labeling and features and benefits) • Upload gemstone, metal and performance testing to specification sheet (where applicable) <ul style="list-style-type: none"> • GIA gem ID (turquoise, new gemstone materials, etc.) • Trademark authorization/approval • Upload Licensing Agreements and releases (as required) <ul style="list-style-type: none"> • Swarovski crystals - letter of authorization • Upload copies of warranty instructions, romance cards certificate of authenticity, etc. • “Bonus” and/or “Gift with Purchase” claims require prior approval from the Legal Department to ensure compliance with FTC guidelines
<p>QA Sample</p>	<p>Production samples must conform to final approved spec sheet and be free from but not limited to the following defects:</p> <ul style="list-style-type: none"> • Dirt, stains, pitting, scratches, excessive glue, fingerprints, polishing compound , residue • Incompatible components, missing parts, loose parts, improper fit • Poor fit/finish, mismatched colors, misaligned patterns/labels/stones • Sharp edges/points, frayed cord/wires, poorly made repairs, excess solder • Symmetry must be maintained with each piece • Clasps must function smoothly and securely

APPENDIX B – GLOSSARY OF JEWELRY TERMS

Alloy: the homogeneous mixture or solid solution of two or more metallic elements or metallic and nonmetallic elements.

Analog Digital Display (watch): uses both digital display and hands to show the time.

Analog Display (watch): uses hands and a dial to show the time; the opposite of digital display.

Anti-Tarnish: a coating on the item or a tab included in the packaging that inhibits tarnish on metals.

Antiqued: a process that involves the application of a dark top coating over bronze or silver; the coating, either plated or painted, is partially removed to expose some of the underlying metal.

Antique Goldtone: simulates the patina of aged gold.

Antique Silvertone: simulates the patina of aged silver.

Applied Finish: a decorative technique in which the surface of the metal is altered; *example: enameling or rhodium accenting.*

Arabic Numerals: 1, 2, 3, 4, 5, 6, 7, 8, 9, 0.

Assembled Stones: Stones that are constructed out of two or more materials. This category includes, for example, such creations as: doublets and triplets, intarsias and inlays, foilbacks and Mabe pearls.

ATM: the water pressure rating of a watch; ATM means “atmosphere” and is equal to 10 meters of depth (1 meter = 3 feet).

Automatic (Watch): the mainspring is wound by the movement of the wearer's wrist rather than from winding a stem; for more details, see *self-winding (watch).*

Bail: a finding that attaches a pendant to a necklace.

Base Metal: non-precious metal; *example: copper, zinc, tin (all metals except platinum, gold, silver, palladium).*

Bead Shapes:

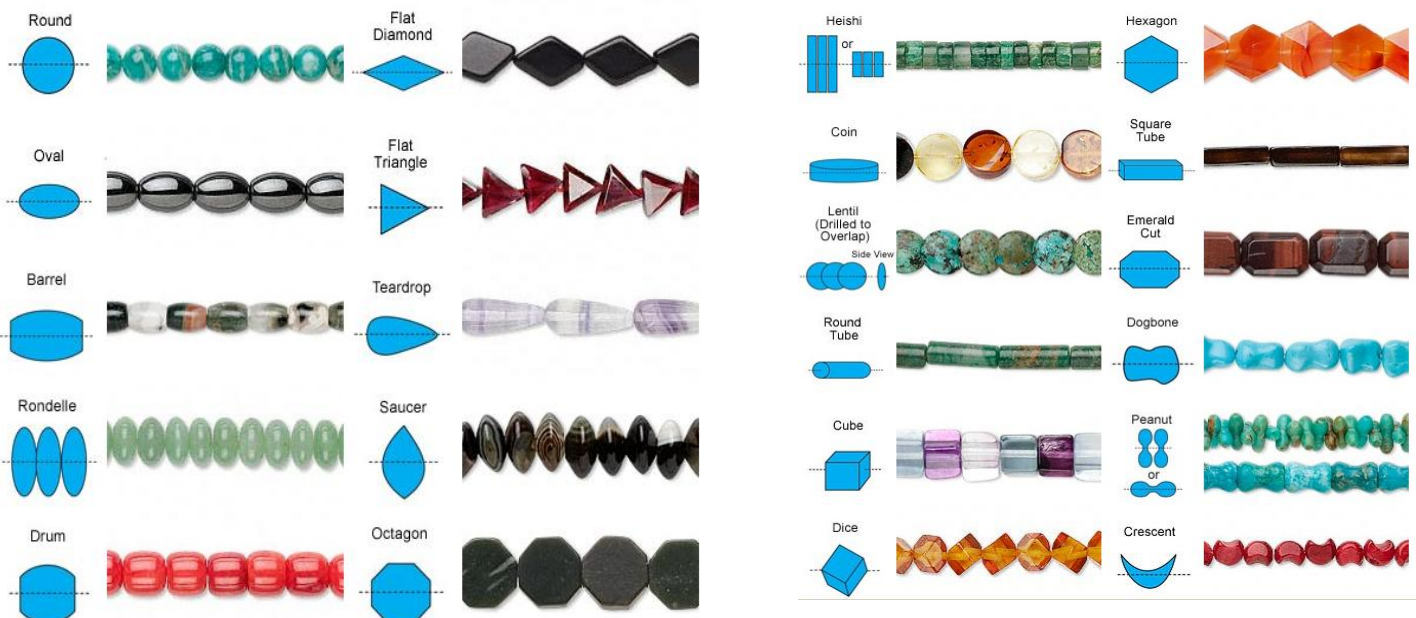

APPENDIX B – GLOSSARY OF JEWELRY TERMS CONTINUED

Bead Shapes:



Coral Bead Strands

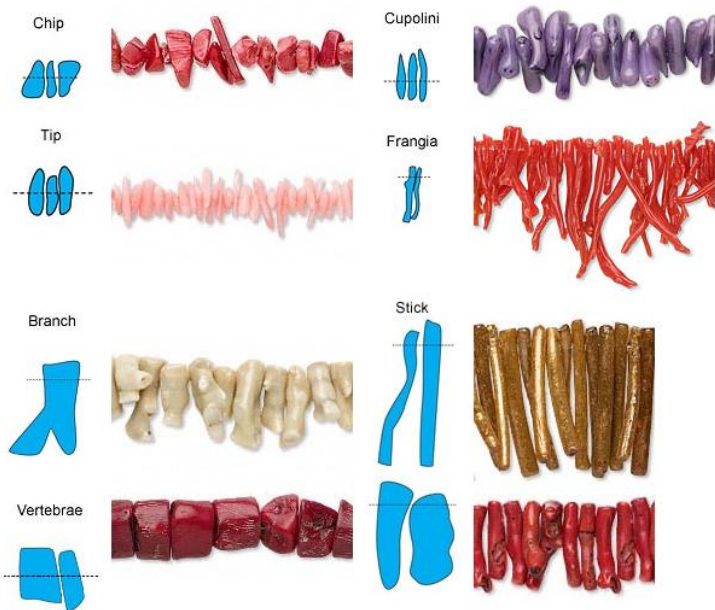

Pearl Bead Strands



APPENDIX B – GLOSSARY OF JEWELRY TERMS CONTINUED

Bezel: the surface ring on a watch that surrounds and holds the crystal in place.

Bi-Directional Rotating Bezel: a bezel that can move either clockwise or counter-clockwise.

Black-Accented: a black color applied to small portion of an item.

Bracelet (Watch): a flexible metal band consisting of assembled links, usually in the same style as the watchcase.

Bronzitone: metallic-brown color.

Cabochon: a stone that has a rounded, domed surface with no facets.

Carat: a standard measure of weight used for gemstones (1 carat weighs 0.20 grams); different from “karat”.

Carat Weight: a unit of measure for the weight of diamonds and/or gemstones; calculated for each individual stone.
example: .53ct.

Case: the metal housing that contains the internal parts of a watch; see *Watchcase* for more information.

Chain Types:

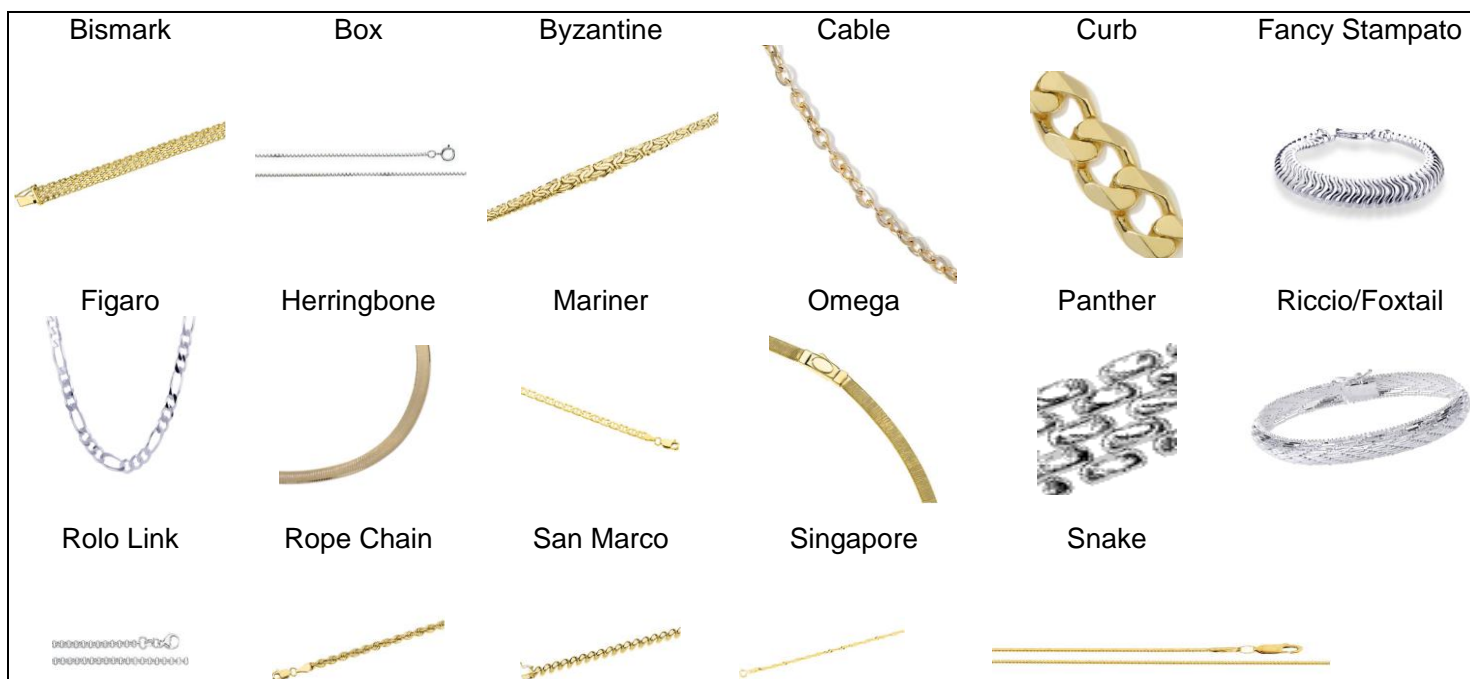

APPENDIX B – GLOSSARY OF JEWELRY TERMS CONTINUED

Clasp Types:

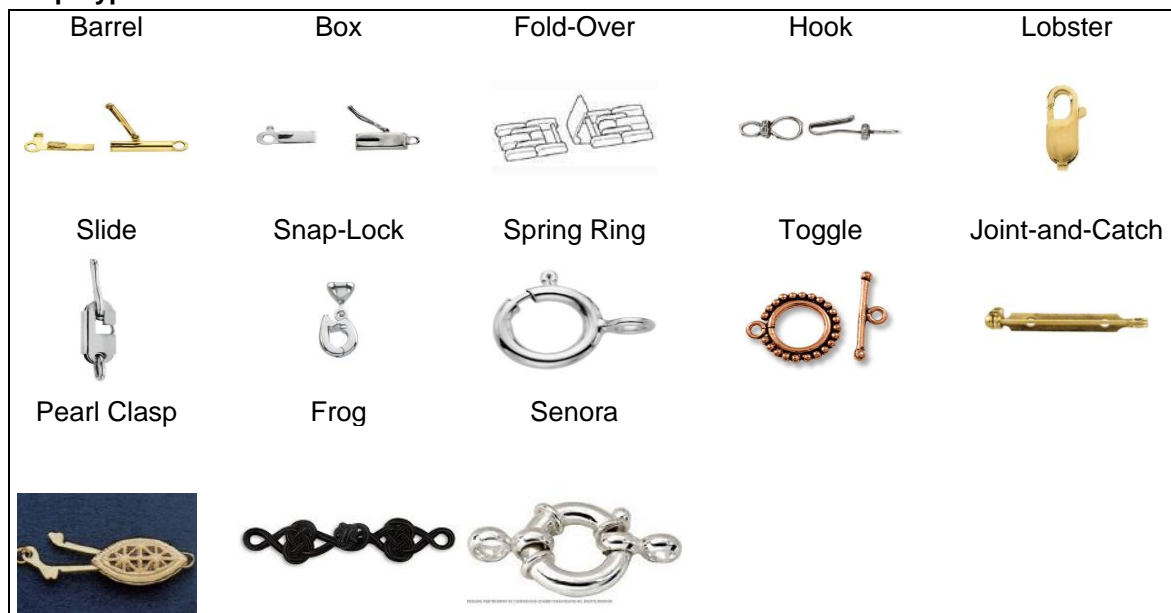

Magnetic:



Safety:

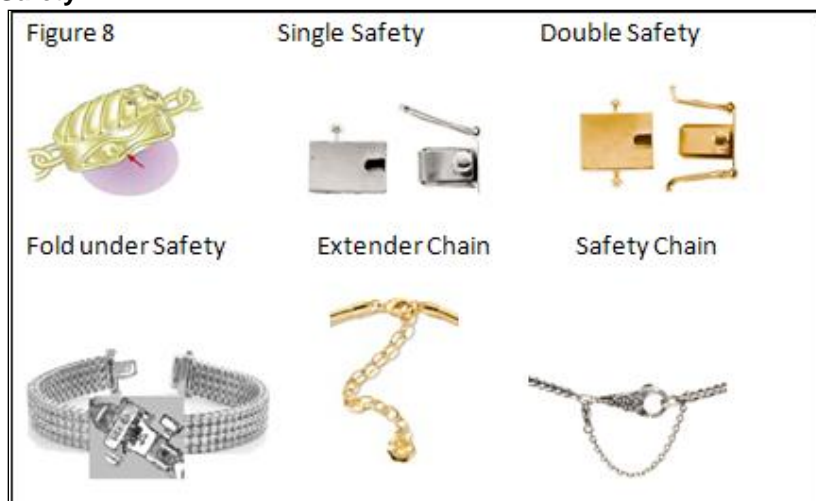

Country of Origin: the country where the product was manufactured, produced or grown. *For Jewelry:* last country for which a “substantial transformation” took place; all imported items must be stamped/labeled with country of origin.

Created Stone: features all the same optical, chemical and physical properties as the natural stone it replicates, but is created in a lab, instead of in nature.

Crown: a nodule extending from the watchcase that is used to set the time and date.

Crystal: the clear cover over the watch face; or stones made from lead crystal, cut & polished for use in jewelry.

Dial: the face of the watch showing the hours, minutes and sometimes, seconds.

APPENDIX B – GLOSSARY OF JEWELRY TERMS CONTINUED

Diamond Cut: The face-up outline shape, and facet arrangement.

A full-cut diamond is a stone that is shaped into a round brilliant cut and has 57 or 58 facets.

As a rule, single-cut diamonds will have only 17 or 18 facets.

FTC regulations require that all diamonds have a minimum of 17 symmetrically fashioned facets.

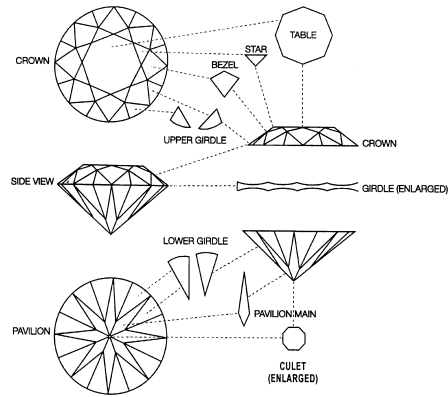
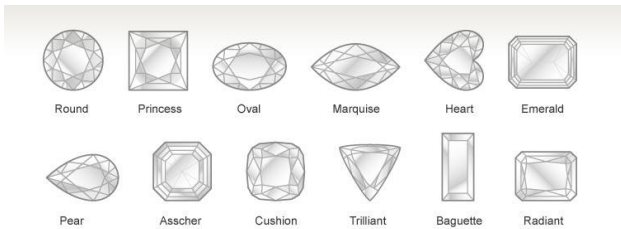

Diamond Clarity: a measure of the number and extent of the flaws in the diamond.

Flawless	Show no inclusions or blemishes under 10x magnification.
Internally Flawless (IF)	Show no inclusions and only insignificant blemishes using 10x magnification.
Very Very Slightly Included (VVS1 and VVS2)	Show minute inclusions that are difficult to see under 10x magnification.
Very Slightly Included (VS1 and VS2)	Show small or minor inclusions observed somewhat easily under 10x magnification (small included crystals, small clouds/feathers, group of pinpoints).
Slightly Included (SI1 and SI2)	Show noticeable inclusions (including crystals, clouds, feathers that are centrally located) that are fairly easy to see under 10x magnification, not visible face up to the eye.
Included (I1)	Show inclusions that are obvious under 10x magnification, quite visible face up to the unaided eye, but do threaten durability.
Included (I2)	Show inclusions that are obvious under 10x magnification, easily visible face up to the unaided eye, but do threaten durability.
Included (I3)	Show inclusions that are obvious under 10x magnification, extremely easy to see face up with the unaided eye, may threaten durability.

Diamond Color: the degree of "yellowness."

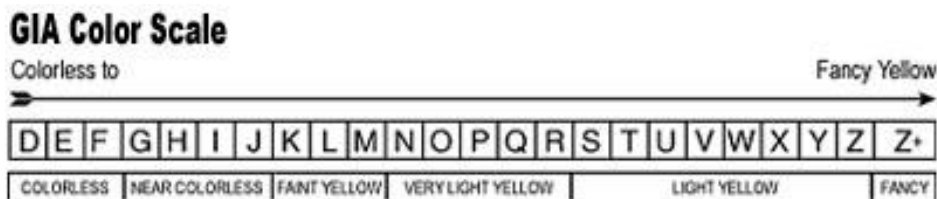

APPENDIX B – GLOSSARY OF JEWELRY TERMS CONTINUED

Diamond Carat Weight in Fractions:

1/20 Ct.	can be	.04 to .06 carat
1/10 Ct.	can be	.09 to .11 carat
1/8 Ct.	can be	.12 to .13 carat
1/7 Ct.	can be	.14 to .15 carat
1/6 Ct.	can be	.16 to .17 carat
1/5 Ct.	can be	.18 to .22 carat
1/4 Ct.	can be	.23 to .29 carat
1/3 Ct.	can be	.30 to .36 carat
3/8 Ct.	can be	.37 to .45 carat
1/2 Ct.	can be	.46 to .58 carat
5/8 Ct.	can be	.59 to .68 carat
3/4 Ct.	can be	.69 to .84 carat
7/8 Ct.	can be	.85 to .95 carat
1 Ct.	can be	.96 to 1.10 carat
1 1/4 Ct.	can be	1.20 to 1.29 carat
1 1/2 Ct.	can be	1.45 to 1.55 carat
1 3/4 Ct.	can be	1.69 to 1.82 carat
2 Ct.	can be	1.95 to 2.05 carat

Dimensions (Jewelry): to locate pictures of how to measure a jewelry item, review the *Jewelry Quality Manual* in the Partner Portal. Click on “Partner Support”, then “Documents & Manuals”. Under “Choose Documents”, select “Partner Requirements Manuals”, then “Jewelry Quality Manual”.

Display Back: a transparent case back that allows you to view watch movement.

Doublet: an assembled gemstone consisting of two pieces of the same or different gem materials (or one gem material and a second of glass)

Drape Length: measured from the top of the drape to the bottom of the drape.

Drop Length: measured from the top of the affixed drop to the bottom of the affixed drop.

Earring Backs:



E-Coat: an electrophoretic coating that provides maximum protection for anti-tarnish and extended wear.

Enamel: a glassy substance (powdered glass with colorants) fused onto metal using heat.

Extender: a short amount of chain added to an existing chain to increase length.

Face (Watch): the visible side of the watch or the dial.

Findings: parts that jewelers use in making jewelry; example: clasps, prongs and links.

Fine Silver: .999 silver; silver in its purest form.

Fineness: the proportion of silver or gold in a metal alloy; usually expressed in parts per thousand.

Finished Weight: the weight, in grams, of the item, including stones.

APPENDIX B – GLOSSARY OF JEWELRY TERMS CONTINUED

Goldtone: yellow color.

Goldtone/Silvertone: yellow and white colors together on one item.

Gold-Plated: 18K gold plating that is 20-mils-thick.

Gunmetal: a metal alloy composed of 90% copper and 10% tin.

Gunmetaltone: dark gray to blackish color.

Hands (watch): the pointing device anchored at the center and circling around the dial; indicates hours, minutes, seconds and any other special features of the watch.

Hematite-tone: steel gray to blackish color.

HSN Item #: unique number given to an item that is created by the HSN Merchandising Department.

Karat: the measure of the fineness of gold equal to a 1/24 part; different from carat.

Lacquered: clear coating on a surface.

Manual-Wind (watch): movement that must be wound manually every 1 to 2 days to keep it running.

Microns: 1/1,000,000m (one-millionth of a meter).

Millimeter: unit of length equal to one-thousandth of a meter, or 0.0394 inch.

Mils: 1/1000in (one-thousandth of an inch).

Movement (watch): the internal components of a watch.

Notes: field used to relay comments to the QA evaluator.

Oxidation: a chemical process in which exposure to oxygen leads to tarnish.

Pavé: stones set very close together, hiding the underlying surface; gives the piece a “cobblestone” look.

Pearl Shapes:



Round: Appears round to the eye.



Semi-Round Appears close to round to the eye. Some might be slightly out-of-round, elongated or flattened.



Drop: (2 Quad) symmetrical, rounded, pear-shaped. May be long drop or short drop.



Baroque: Non-symmetrical shape. Will have a noticeably irregular shape.



Circlé: Pearls that have one or more grooved or ridged rings are considered circled .



Button: Symmetrical shape, flattened, or slightly flattened, circular shape. May be a high button or a low button.

APPENDIX B – GLOSSARY OF JEWELRY TERMS CONTINUED

Pinion (watch): a toothed wheel (usually made of steel) with a small number of teeth.

Plating: use of a plating solution to form a layer of metal on an object.

Plating Fineness: the karat fineness of gold or alloy used in the plating process.

Plating Thickness: the thickness of the plating material listed in either “mils” or “microns.”

Quartz Crystal (watch): works with a series of electronic components, all fitting together in a tiny space, instead of using a wound spring; powered by a battery.

Ratchet Bezel Ring: a ring that can either turn counterclockwise or both ways and generally clicks into place.

Rhodium Accenting: rhodium applied to a small portion of the item, such as on the tips of prongs.

Rhodium Plating: a layer of rhodium on top of a metal (usually sterling silver); thickness should be 3 to 5 mils.

Romance Card: an insert that gives detail and romances the item being sold.

Rose-Cut Diamond: the shape resembles the petals of a rose bud; the crown is domed and the facets meet at a point in the center.

Rosetone: rose or pinkish color.

Safety Chain: a secondary closure, usually on a fine bracelet or watch, that is used to prevent the primary clasp from opening; helps stop the piece from getting lost.

Self-Winding (watch): mainspring is wound by the movement of the wearer's wrist rather than from winding a stem; see *Automatic (watch)*.

Setting: a method of securing a stone.

Shank: the part of a ring that encircles the finger, excluding the head.

Silvertone: metallic gray color.

Simulated Stone: features optical properties that resemble those of the natural gem it is trying to imitate in look and form; often made of glass, crystal or another similar, rock-like substance that replicates the look of a genuine stone created in nature.

Single-Cut Diamond: features an octagonal girdle, a table, eight bezel (or crown) facets and 8 pavilion facets; it may or may not have a culet.

Slide Rule Bezel (watch): a rotating bezel, or ring, around the outside edge of the case that is printed with a logarithmic scale and assorted other scales; is used in conjunction with fixed rules of mathematics to perform general mathematical calculations or navigational computations.

Stem (watch): the shaft that connects to the movement's winding mechanism.

Stone Color: the color of the stone being identified. (Note: “clear” is not the color “white”; it should be listed as “clear”).
Hue: first impression of a stone's basic color. Tone: degree of darkness/lightness of a stone. Saturation: strength or intensity of a stone's color.

Stone Detail: the area of the spec sheet where all the stone characteristics are disclosed. If not listed in drop down, enter the information in the “other” text box.

Stone Type: identifies whether the stone is natural, created or simulated.

Stone Variety: the type or kind of stone being detailed.

APPENDIX B – GLOSSARY OF JEWELRY TERMS CONTINUED

Strap (watch): a watchband made of leather, plastic or fabric.

Sub-Dial (watch): a small dial on the watch face that displays elapsed durations of time.

Surface Finish: the polish or texture applied to a metal as seen below

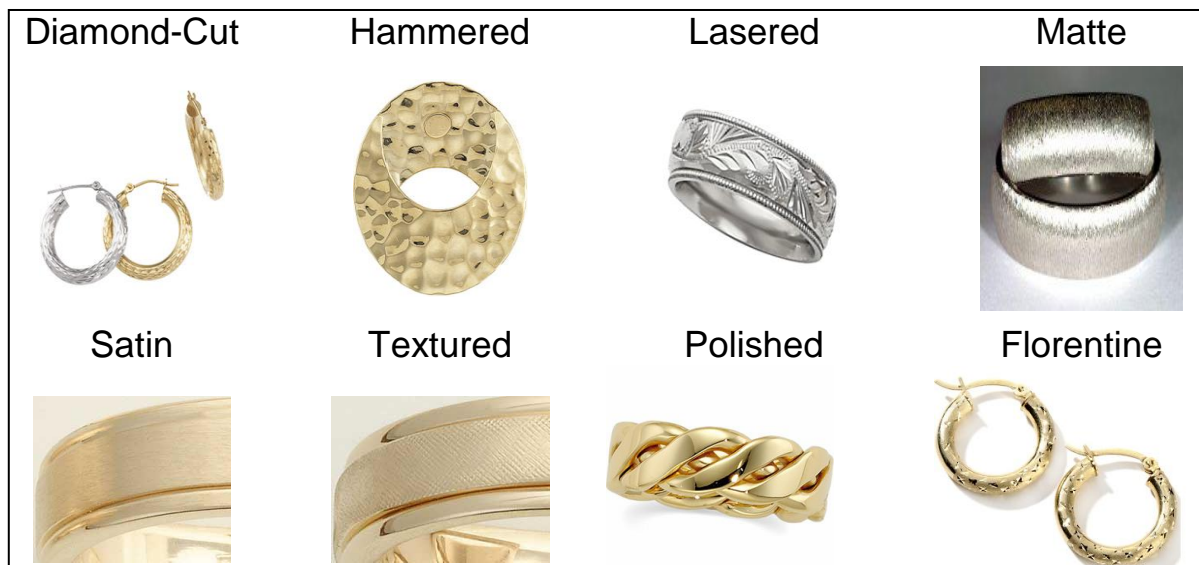

Sweep-Seconds Hand: a seconds hand that is mounted in the center of the watch dial, instead of in a sub-dial.

Swiss Movement: a movement is considered Swiss if it has been assembled in Switzerland, inspected by the manufacturer in Switzerland and components of its Swiss manufacturing account for at least 50% of the total value (without taking cost of assembly into account).

Tarnish: the term applied to metal that has discolored due to oxidation or corrosion.

Technibond™ Yellow: .925 sterling silver plated with a 40-mils-thick outside layer of 18K yellow gold.

Technibond™ Platinum: .925 sterling silver plated with a layer of platinum.

Technibond™ Rose: .925 sterling silver plated with a 40-mils-thick outside layer of 18K rose gold.

Total Carat Weight: a unit of measure of the combined carat weight of all diamonds and/or gemstones in a piece of jewelry.

Tourbillon (watch): consists of a mobile carriage holding all the parts of the escapement, with the balance in the center.

Treatment disclosure: gemstones may be treated in numerous ways to enhance their appearance. It is unfair/deceptive to fail to disclose that a gemstone has been treated if (1) the treatment is not permanent (2) the treatment creates special care requirements (3) the treatment has a significant effect on the value of the stone.

- natural materials are formed completely by nature, modified only by cutting, polishing and processes which are commonly accepted before and after cutting to improve color or clarity.
- synthetic/created gemstones are created by humans in a lab, with the same properties as its natural counterpart.
- cultured pearls are produced by the human insertion of a bead, tissue graft, or both, in a freshwater or saltwater mollusk or mussel.

Triplet: an assembled stone composed of three parts.

Two-Tone: combination of any 2 metal colors.

APPENDIX B – GLOSSARY OF JEWELRY TERMS CONTINUED

Type/Shape of Cut: the shape or the cut of the stone. Examples below:

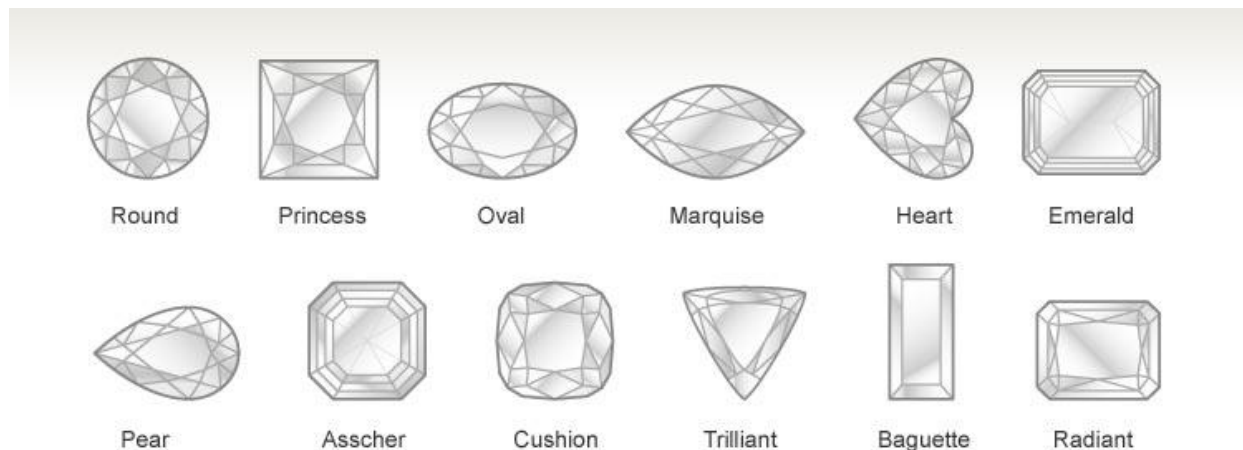

Uni-Directional Rotating Bezel (watch): a bezel that indicates elapsed time; often found on diver's watches.

Variant: Describes either a color, size, or other characteristic for choices offered on one item.

Vendor Part Number (VPN): unique numeric or alphanumeric identifier created by the partner.

Vermeil: .925 sterling silver that is plated with a 100-mils-thick (2.5 microns) layer of 18K gold.

Vibration (watch): movement of a pendulum limited by 2 extreme positions.

Warranty Card: a guarantee given to the purchaser by a company stating that a product is reliable and free from known defects and that the seller will, without charge, repair or replace defective parts within a given time limit and under certain conditions.

Watchcase: the metal housing that contains the internal parts of a watch; see *Case*.

Water Resistance (watch): the ability of a watch to resist penetration by water.

White Gold: an alloy of gold made with nickel; sometimes the jeweler also mixes palladium or zinc in the alloy.

Winding Stem (watch): the button on the right side of the watchcase used to wind the mainspring.