

CONTENTS

Chapter 1	1
Chapter 2	11
Chapter 3	51
Chapter 4	89
Chapter 5	191
Chapter 6	211
Chapter 7	233
Chapter 8	293
Chapter 9	319
Chapter 10	333
Chapter 11	355
Chapter 12	375

Chapter 1

1.1

- (a) One dimensional, multichannel, discrete time, and digital.
- (b) Multi dimensional, single channel, continuous-time, analog.
- (c) One dimensional, single channel, continuous-time, analog.
- (d) One dimensional, single channel, continuous-time, analog.
- (e) One dimensional, multichannel, discrete-time, digital.

1.2

- (a) $f = \frac{0.01\pi}{2\pi} = \frac{1}{200} \Rightarrow$ periodic with $N_p = 200$.
- (b) $f = \frac{36\pi}{105}(\frac{1}{2\pi}) = \frac{1}{7} \Rightarrow$ periodic with $N_p = 7$.
- (c) $f = \frac{3\pi}{2\pi} = \frac{3}{2} \Rightarrow$ periodic with $N_p = 2$.
- (d) $f = \frac{2\pi}{2\pi} \Rightarrow$ non-periodic.
- (e) $f = \frac{62\pi}{10}(\frac{1}{2\pi}) = \frac{31}{10} \Rightarrow$ periodic with $N_p = 10$.

1.3

- (a) Periodic with period $T_p = \frac{2\pi}{5}$.
- (b) $f = \frac{5}{2\pi} \Rightarrow$ non-periodic.
- (c) $f = \frac{1}{12\pi} \Rightarrow$ non-periodic.
- (d) $\cos(\frac{\pi n}{8})$ is non-periodic; $\cos(\frac{\pi n}{8})$ is periodic; Their product is non-periodic.
- (e) $\cos(\frac{\pi n}{2})$ is periodic with period $N_p=4$
 $\sin(\frac{\pi n}{8})$ is periodic with period $N_p=16$
 $\cos(\frac{\pi n}{4} + \frac{\pi}{3})$ is periodic with period $N_p=8$
Therefore, $x(n)$ is periodic with period $N_p=16$. (16 is the least common multiple of 4,8,16).

1.4

- (a) $w = \frac{2\pi k}{N}$ implies that $f = \frac{k}{N}$. Let

$$\alpha = \text{GCD of } (k, N), \text{ i.e.,}$$

$$k = k'\alpha, N = N'\alpha.$$

Then,

$$f = \frac{k'}{N'}, \text{ which implies that}$$

$$N' = \frac{N}{\alpha}.$$

(b)

$$\begin{aligned} N &= 7 \\ k &= 0\ 1\ 2\ 3\ 4\ 5\ 6\ 7 \\ \text{GCD}(k, N) &= 7\ 1\ 1\ 1\ 1\ 1\ 1\ 7 \\ N_p &= 1\ 7\ 7\ 7\ 7\ 7\ 1\ 1 \end{aligned}$$

(c)

$$\begin{aligned} N &= 16 \\ k &= 0\ 1\ 2\ 3\ 4\ 5\ 6\ 7\ 8\ 9\ 10\ 11\ 12\ \dots\ 16 \\ \text{GCD}(k, N) &= 16\ 1\ 2\ 1\ 4\ 1\ 2\ 1\ 8\ 1\ 2\ 1\ 4\ \dots\ 16 \\ N_p &= 1\ 6\ 8\ 16\ 4\ 16\ 8\ 16\ 2\ 16\ 8\ 16\ 4\ \dots\ 1 \end{aligned}$$

1.5

(a) Refer to fig 1.1

(b)

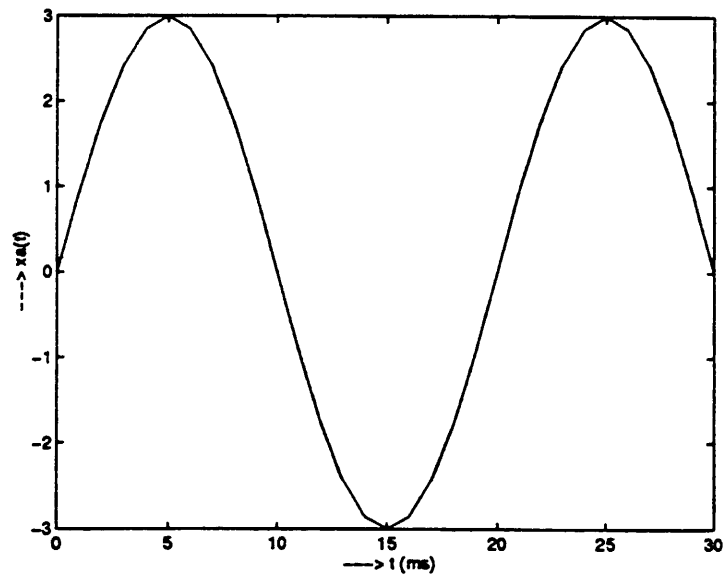

Figure 1.1:

$$\begin{aligned} x(n) &= x_a(nT) \\ &= x_a(n/F_s) \\ &= 3\sin(\pi n/3) \Rightarrow \\ f &= \frac{1}{2\pi} \left(\frac{\pi}{3} \right) \\ &= \frac{1}{6}, N_p = 6 \end{aligned}$$

(c) Refer to fig 1.2

$$x(n) = \left\{ 0, \frac{3}{\sqrt{2}}, \frac{3}{\sqrt{2}}, 0, -\frac{3}{\sqrt{2}}, -\frac{3}{\sqrt{2}} \right\}, N_p = 6.$$

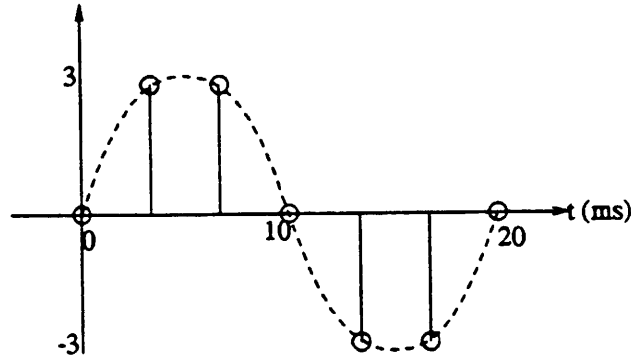

Figure 1.2:

(d) Yes.

$$x(1) = 3 = 3 \sin\left(\frac{100\pi}{F_s}\right) \Rightarrow F_s = 200 \text{ samples/sec.}$$

1.6

(a)

$$\begin{aligned} x(n) &= A \cos(2\pi F_0 n / F_s + \theta) \\ &= A \cos(2\pi (T/T_p) n + \theta) \end{aligned}$$

But $T/T_p = f \Rightarrow x(n)$ is periodic if f is rational.

(b) If $x(n)$ is periodic, then $f = k/N$ where N is the period. Then,

$$T_d = \left(\frac{k}{f}\right)T = k\left(\frac{T_p}{T}\right)T = kT_p.$$

Thus, it takes k periods (kT_p) of the analog signal to make 1 period (T_d) of the discrete signal.

(c) $T_d = kT_p \Rightarrow NT = kT_p \Rightarrow f = k/N = T/T_p \Rightarrow f$ is rational $\Rightarrow x(n)$ is periodic.

1.7

(a) $F_{\max} = 10 \text{ kHz} \Rightarrow F_s \geq 2F_{\max} = 20 \text{ kHz}$.

(b) For $F_s = 8 \text{ kHz}$, $F_{\text{fold}} = F_s/2 = 4 \text{ kHz} \Rightarrow 5 \text{ kHz}$ will alias to 3 kHz .

(c) $F = 9 \text{ kHz}$ will alias to 1 kHz .

1.8

(a) $F_{\max} = 100 \text{ kHz}$, $F_s \geq 2F_{\max} = 200 \text{ Hz}$.

(b) $F_{\text{fold}} = \frac{F_s}{2} = 125 \text{ Hz}$.

1.9

(a) $F_{\max} = 360 \text{ Hz}, F_N = 2F_{\max} = 720 \text{ Hz}.$

(b) $F_{\text{fold}} = \frac{F_s}{2} = 300 \text{ Hz}.$

(c)

$$\begin{aligned}x(n) &= x_a(nT) \\ &= x_a(n/F_s) \\ &= \sin(480\pi n/600) + 3\sin(720\pi n/600) \\ x(n) &= \sin(4\pi n/5) - 3\sin(4\pi n/5) \\ &= -2\sin(4\pi n/5).\end{aligned}$$

Therefore, $w = 4\pi/5$.

(d) $y_a(t) = x(F_s t) = -2\sin(480\pi t).$

1.10

(a)

$$\begin{aligned}\text{Number of bits/sample} &= \log_2 1024 = 10. \\ F_s &= \frac{[10,000 \text{ bits/sec}]}{[10 \text{ bits/sample}]} \\ &= 1000 \text{ samples/sec.} \\ F_{\text{fold}} &= 500 \text{ Hz.}\end{aligned}$$

(b)

$$\begin{aligned}F_{\max} &= \frac{1800\pi}{2\pi} \\ &= 900 \text{ Hz;} \\ F_N &= 2F_{\max} = 1800 \text{ Hz.}\end{aligned}$$

(c)

$$\begin{aligned}f_1 &= \frac{600\pi}{2\pi} \left(\frac{1}{F_s}\right) \\ &= 0.3; \\ f_2 &= \frac{1800\pi}{2\pi} \left(\frac{1}{F_s}\right) \\ &= 0.9;\end{aligned}$$

But $f_2 = 0.9 > 0.5 \Rightarrow f_2 = 0.1.$

Hence, $x(n) = 3\cos[(2\pi)(0.3)n] + 2\cos[(2\pi)(0.1)n]$

(d) $\Delta = \frac{x_{\max} - x_{\min}}{m-1} = \frac{5 - (-5)}{1023} = \frac{10}{1023}.$

1.11

$$\begin{aligned}x(n) &= x_a(nT) \\ &= 3\cos\left(\frac{100\pi n}{200}\right) + 2\sin\left(\frac{250\pi n}{200}\right)\end{aligned}$$

$$\begin{aligned}
&= 3\cos\left(\frac{\pi n}{2}\right) - 2\sin\left(\frac{3\pi n}{4}\right) \\
T' &= \frac{1}{1000} \Rightarrow y_a(t) = x(t/T') \\
&= 3\cos\left(\frac{\pi 1000t}{2}\right) - 2\sin\left(\frac{3\pi 1000t}{4}\right) \\
y_a(t) &= 3\cos(500\pi t) - 2\sin(750\pi t)
\end{aligned}$$

1.12

(a) For $F_s = 300\text{Hz}$,

$$\begin{aligned}
x(n) &= 3\cos\left(\frac{\pi n}{6}\right) + 10\sin(\pi n) - \cos\left(\frac{\pi n}{3}\right) \\
&= 3\cos\left(\frac{\pi n}{6}\right) - 3\cos\left(\frac{\pi n}{3}\right)
\end{aligned}$$

(b) $x_r(t) = 3\cos(10000\pi t/6) - \cos(10000\pi t/3)$

1.13

(a)

$$\begin{aligned}
\text{Range} &= x_{\max} - x_{\min} = 12.7. \\
m &= 1 + \frac{\text{range}}{\Delta} \\
&= 127 + 1 = 128 \Rightarrow \log_2(128) \\
&= 7 \text{ bits.}
\end{aligned}$$

(b) $m = 1 + \frac{127}{0.02} = 636 \Rightarrow \log_2(636) \Rightarrow 10 \text{ bit A/D.}$

1.14

$$\begin{aligned}
R &= \left(20 \frac{\text{samples}}{\text{sec}}\right) \left(8 \frac{\text{bits}}{\text{sample}}\right) \\
&= 160 \frac{\text{bits}}{\text{sec}} \\
F_{\text{fold}} &= \frac{F_s}{2} = 10\text{Hz.} \\
\text{Resolution} &= \frac{1\text{volt}}{2^8 - 1} \\
&= 0.004.
\end{aligned}$$

1.15

(a) Refer to fig 1.3. With a sampling frequency of 5kHz, the maximum frequency that can be represented is 2.5kHz. Therefore, a frequency of 4.5kHz is aliased to 500Hz and the frequency of 3kHz is aliased to 2kHz.

(b) Refer to fig 1.4. $y(n)$ is a sinusoidal signal. By taking the even numbered samples, the sampling frequency is reduced to half i.e., 25kHz which is still greater than the nyquist rate. The frequency of the downsampled signal is 2kHz.

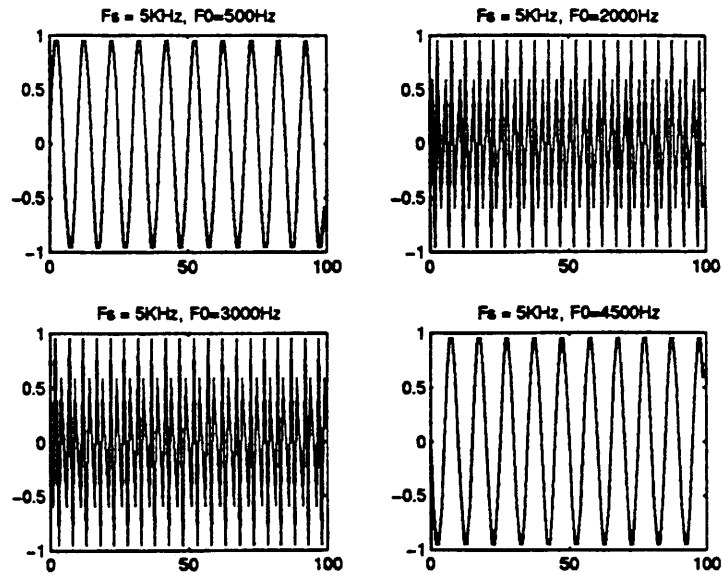

Figure 1.3:

1.16

- (a) for levels = 64, using truncation refer to fig 1.5.
 for levels = 128, using truncation refer to fig 1.6.
 for levels = 256, using truncation refer to fig 1.7.
- (b) for levels = 64, using rounding refer to fig 1.8.
 for levels = 128, using rounding refer to fig 1.9.
 for levels = 256, using rounding refer to fig 1.10.
- (c) The sqnr with rounding is greater than with truncation. But the sqnr improves as the number of quantization levels are increased.
- (d)

levels	64	128	256
theoretical sqnr	43.9000	49.9200	55.9400
sqnr with truncation	31.3341	37.359	43.7739
sqnr with rounding	32.754	39.2008	44.0353

The theoretical sqnr is given in the table above. It can be seen that theoretical sqnr is much higher than those obtained by simulations. The decrease in the sqnr is because of the truncation and rounding.

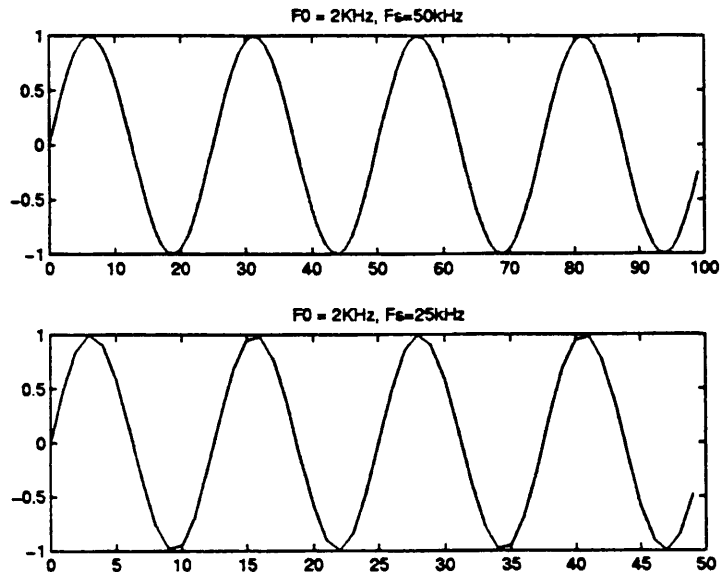

Figure 1.4:

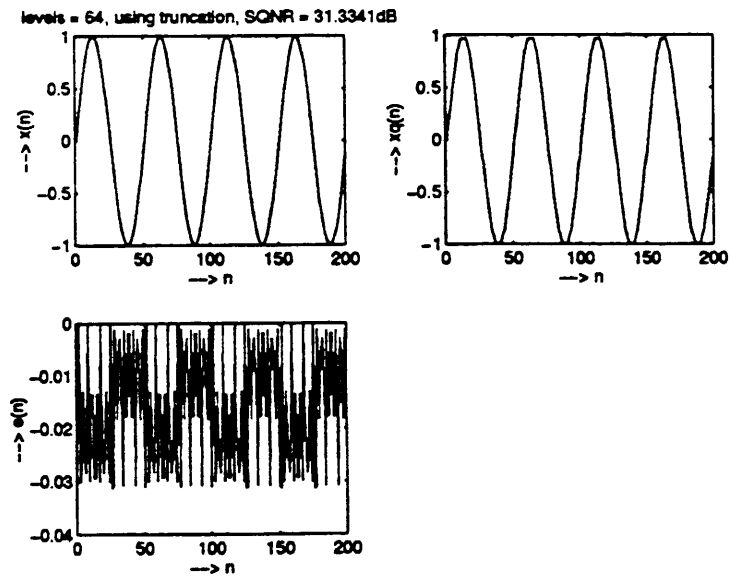

Figure 1.5:

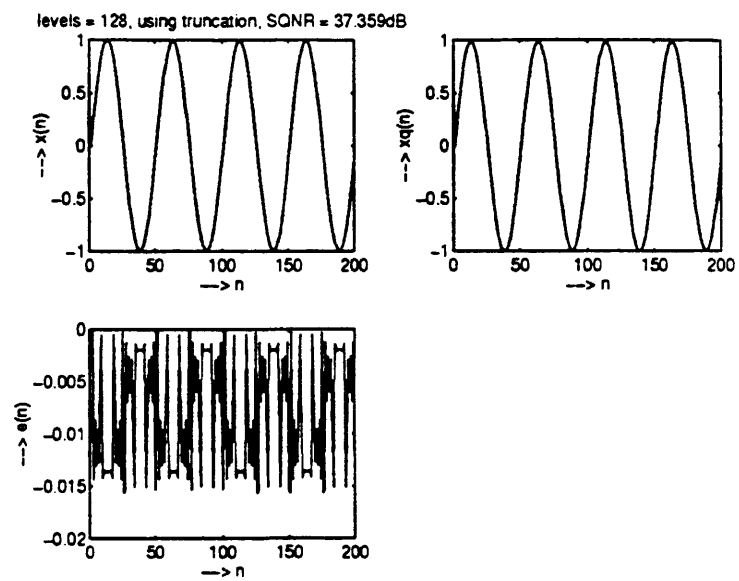

Figure 1.6:

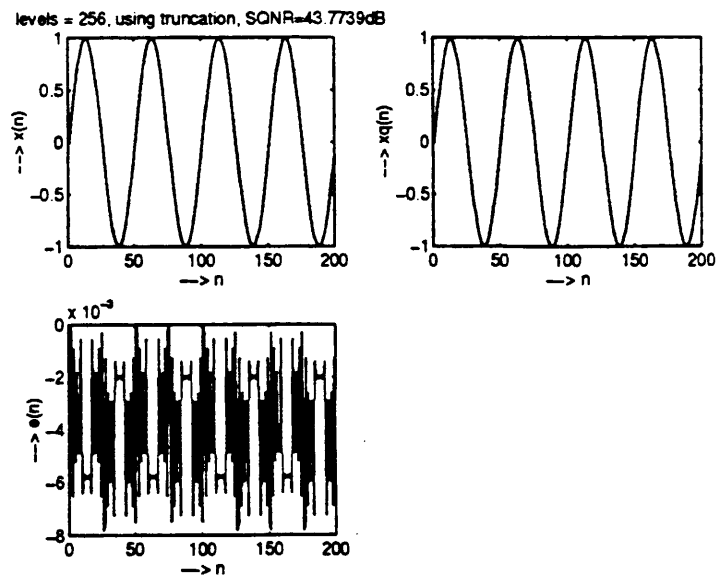

Figure 1.7:

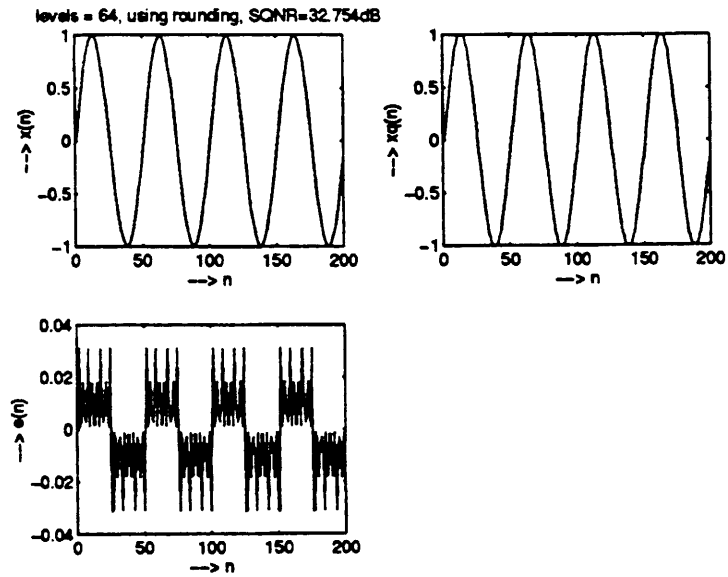

Figure 1.8:

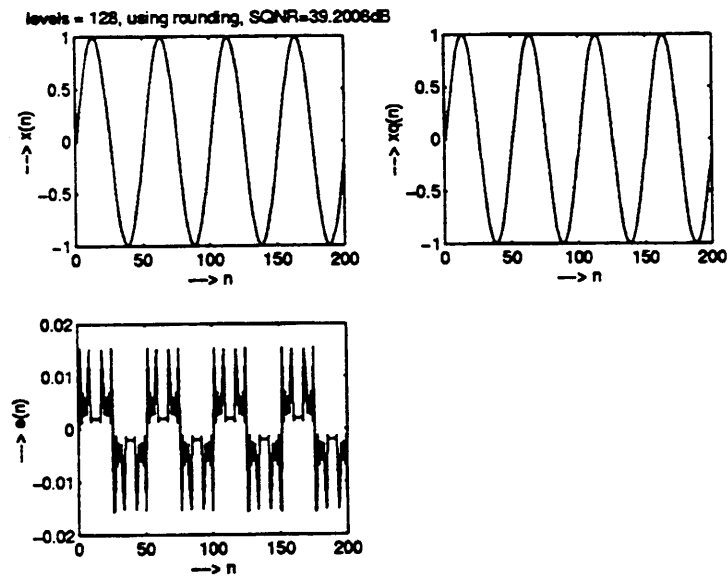

Figure 1.9:

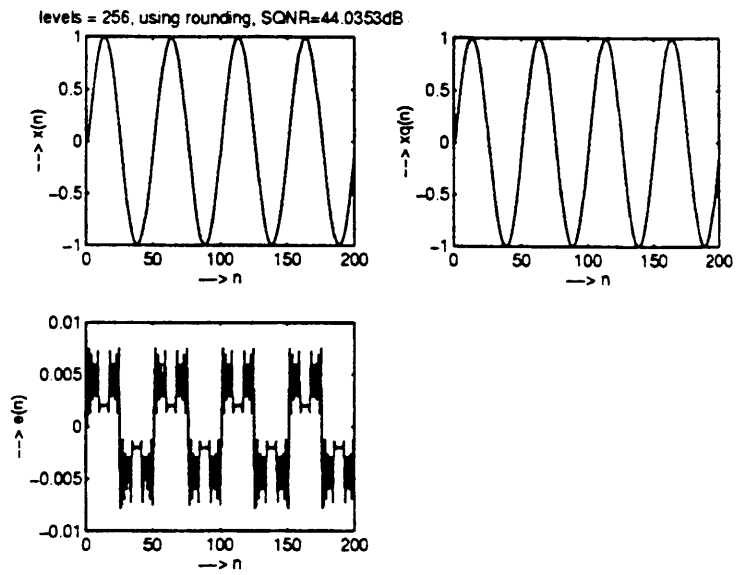

Figure 1.10:

Chapter 2

2.1

(a)

$$x(n) = \left\{ \dots, 0, \frac{1}{3}, \frac{2}{3}, \underset{\uparrow}{1}, 1, 1, 1, 0, \dots \right\}$$

Refer to fig 2.1.

(b) After folding $s(n)$ we have

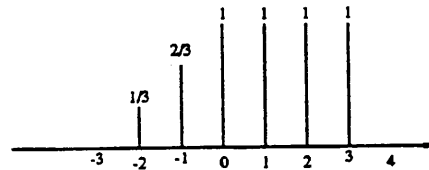

Figure 2.1:

$$x(-n) = \left\{ \dots, 0, 1, 1, 1, \underset{\uparrow}{1}, \frac{2}{3}, \frac{1}{3}, 0, \dots \right\}.$$

After delaying the folded signal by 4 samples, we have

$$x(-n+4) = \left\{ \dots, 0, \underset{\uparrow}{0}, 1, 1, 1, 1, \frac{2}{3}, \frac{1}{3}, 0, \dots \right\}.$$

On the other hand, if we delay $x(n)$ by 4 samples we have

$$x(n-4) = \left\{ \dots, 0, \underset{\uparrow}{0}, \frac{1}{3}, \frac{2}{3}, 1, 1, 1, 1, 0, \dots \right\}.$$

Now, if we fold $x(n-4)$ we have

$$x(-n-4) = \left\{ \dots, 0, 1, 1, 1, 1, \frac{2}{3}, \frac{1}{3}, \underset{\uparrow}{0}, 0, \dots \right\}$$

(c)

$$x(-n+4) = \left\{ \dots 0, \underset{\uparrow}{1}, 1, 1, 1, \frac{2}{3}, \frac{1}{3}, 0, \dots \right\}$$

(d) To obtain $x(-n+k)$, first we fold $x(n)$. This yields $x(-n)$. Then, we shift $x(-n)$ by k samples to the right if $k > 0$, or k samples to the left if $k < 0$.

(e) Yes.

$$x(n) = \frac{1}{3}\delta(n-2) + \frac{2}{3}\delta(n+1) + u(n) - u(n-4)$$

2.2

$$x(n) = \left\{ \dots 0, \underset{\uparrow}{1}, 1, 1, \frac{1}{2}, \frac{1}{2}, 0, \dots \right\}$$

(a)

$$x(n-2) = \left\{ \dots 0, \underset{\uparrow}{0}, 1, 1, 1, \frac{1}{2}, \frac{1}{2}, 0, \dots \right\}$$

(b)

$$x(4-n) = \left\{ \dots 0, \frac{1}{2}, \frac{1}{2}, \underset{\uparrow}{1}, 1, 1, 1, 0, \dots \right\}$$

(see 2.1(d))

(c)

$$x(n+2) = \left\{ \dots 0, 1, 1, 1, \underset{\uparrow}{1}, \frac{1}{2}, \frac{1}{2}, 0, \dots \right\}$$

(d)

$$x(n)u(2-n) = \left\{ \dots 0, \underset{\uparrow}{1}, 1, 1, 0, 0, \dots \right\}$$

(e)

$$x(n-1)\delta(n-3) = \left\{ \dots 0, \underset{\uparrow}{0}, 0, 1, 0, \dots \right\}$$

(f)

$$\begin{aligned} x(n^2) &= \{ \dots 0, x(4), x(1), x(0), x(1), x(4), 0, \dots \} \\ &= \left\{ \dots 0, \frac{1}{2}, \underset{\uparrow}{1}, 1, \frac{1}{2}, 0, \dots \right\} \end{aligned}$$

(g)

$$\begin{aligned} x_e(n) &= \frac{x(n) + x(-n)}{2}, \\ x(-n) &= \left\{ \dots 0, \frac{1}{2}, \frac{1}{2}, \underset{\uparrow}{1}, 1, 1, 0, \dots \right\} \\ &= \left\{ \dots 0, \frac{1}{4}, \frac{1}{4}, \frac{1}{2}, \underset{\uparrow}{1}, 1, \frac{1}{2}, \frac{1}{4}, \frac{1}{4}, 0, \dots \right\} \end{aligned}$$

(h)

$$\begin{aligned}x_o(n) &= \frac{x(n) - x(-n)}{2} \\ &= \left\{ \dots, 0, -\frac{1}{4}, -\frac{1}{4}, -\frac{1}{2}, 0, 0, 0, \frac{1}{2}, \frac{1}{4}, \frac{1}{4}, 0, \dots \right\}\end{aligned}$$

2.3

(a)

$$u(n) - u(n-1) = \delta(n) = \begin{cases} 0, & n < 0 \\ 1, & n = 0 \\ 0, & n > 0 \end{cases}$$

(b)

$$\begin{aligned}\sum_{k=-\infty}^n \delta(k) = u(n) &= \begin{cases} 0, & n < 0 \\ 1, & n \geq 0 \end{cases} \\ \sum_{k=0}^{\infty} \delta(n-k) &= \begin{cases} 0, & n < 0 \\ 1, & n \geq 0 \end{cases}\end{aligned}$$

2.4

Let

$$x_e(n) = \frac{1}{2}[x(n) + x(-n)],$$

$$x_o(n) = \frac{1}{2}[x(n) - x(-n)].$$

Since

$$x_e(-n) = x_e(n)$$

and

$$x_o(-n) = -x_o(n),$$

it follows that

$$x(n) = x_e(n) + x_o(n).$$

The decomposition is unique. For

$$x(n) = \left\{ 2, 3, 4, \underset{\uparrow}{4}, 5, 6 \right\},$$

we have

$$x_e(n) = \left\{ 4, 4, 4, \underset{\uparrow}{4}, 4, 4 \right\}$$

and

$$x_o(n) = \left\{ -2, -1, 0, \underset{\uparrow}{1}, 2 \right\}.$$

2.5

First, we prove that

$$\begin{aligned} \sum_{n=-\infty}^{\infty} x_e(n)x_o(n) &= 0 \\ \sum_{n=-\infty}^{\infty} x_e(n)x_o(n) &= \sum_{m=-\infty}^{\infty} x_e(-m)x_o(-m) \\ &= - \sum_{m=-\infty}^{\infty} x_e(m)x_o(m) \\ &= - \sum_{n=-\infty}^{\infty} x_e(n)x_o(n) \\ &= \sum_{n=-\infty}^{\infty} x_e(n)x_o(n) \\ &= 0 \end{aligned}$$

Then,

$$\begin{aligned} \sum_{n=-\infty}^{\infty} x^2(n) &= \sum_{n=-\infty}^{\infty} [x_e(n) + x_o(n)]^2 \\ &= \sum_{n=-\infty}^{\infty} x_e^2(n) + \sum_{n=-\infty}^{\infty} x_o^2(n) + \sum_{n=-\infty}^{\infty} 2x_e(n)x_o(n) \\ &= E_e + E_o \end{aligned}$$

2.6

(a) No, the system is time variant. Proof: If

$$\begin{aligned} x(n) \rightarrow y(n) &= x(n^2) \\ x(n-k) \rightarrow y_1(n) &= x[(n-k)^2] \\ &= x(n^2 + k^2 - 2nk) \\ &\neq y(n-k) \end{aligned}$$

(b) (1)

$$x(n) = \left\{ 0, \underset{\uparrow}{1}, 1, 1, 1, 0, \dots \right\}$$

(2)

$$y(n) = x(n^2) = \left\{ \dots, 0, 1, \underset{\uparrow}{1}, 1, 0, \dots \right\}$$

(3)

$$y(n-2) = \left\{ \dots, 0, 0, \underset{\uparrow}{1}, 1, 1, 0, \dots \right\}$$

(4)

$$x(n-2) = \left\{ \dots, 0, 0, 1, 1, 1, 1, 0, \dots \right\}$$

(5)

$$y_2(n) = \mathcal{T}[x(n-2)] = \left\{ \dots, 0, 1, 0, 0, 0, 1, 0, \dots \right\}$$

(6)

$$y_2(n) \neq y(n-2) \Rightarrow \text{system is time variant.}$$

(c) (1)

$$x(n) = \left\{ 1, 1, 1, 1 \right\}$$

(2)

$$y(n) = \{1, 0, 0, 0, 0, -1\}$$

(3)

$$y(n-2) = \left\{ 0, 0, 1, 0, 0, 0, 0, -1 \right\}$$

(4)

$$x(n-2) = \left\{ 0, 0, 1, 1, 1, 1, 1 \right\}$$

(5)

$$y_2(n) = \left\{ 0, 0, 1, 0, 0, 0, 0, -1 \right\}$$

(6)

$$y_2(n) = y(n-2).$$

The system is time invariant, but this example alone does not constitute a proof.

(d) (1)

$$y(n) = nx(n),$$

$$x(n) = \left\{ \dots, 0, 1, 1, 1, 1, 0, \dots \right\}$$

(2)

$$y(n) = \left\{ \dots, 0, 1, 2, 3, \dots \right\}.$$

(3)

$$y(n-2) = \left\{ \dots, 0, 0, 0, 1, 2, 3, \dots \right\}$$

(4)

$$x(n-2) = \left\{ \dots, 0, 0, 0, 1, 1, 1, 1, \dots \right\}$$

(5)

$$y_2(n) = T[x(n-2)] = \{\dots, 0, 0, 2, 3, 4, 5, \dots\}$$

(6)

$y_2(n) \neq y(n-2) \Rightarrow$ the system is time variant.

2.7

- (a) Static, nonlinear, time invariant, causal, stable.
 (b) Dynamic, linear, time invariant, noncausal and unstable. The latter is easily proved.
 For the bounded input $x(k) = u(k)$, the output becomes

$$y(n) = \sum_{k=-\infty}^{n+1} u(k) = \begin{cases} 0, & n < -1 \\ n+2, & n \geq -1 \end{cases}$$

since $y(n) \rightarrow \infty$ as $n \rightarrow \infty$, the system is unstable.

- (c) Static, linear, timevariant, causal, stable.
 (d) Dynamic, linear, time invariant, noncausal, stable.
 (e) Static, nonlinear, time invariant, causal, stable.
 (f) Static, nonlinear, time invariant, causal, stable.
 (g) Static, nonlinear, time invariant, causal, stable.
 (h) Static, linear, time invariant, causal, stable.
 (i) Dynamic, linear, time variant, noncausal, unstable. Note that the bounded input $x(n) = u(n)$ produces an unbounded output.
 (j) Dynamic, linear, time variant, noncausal, stable.
 (k) Static, nonlinear, time invariant, causal, stable.
 (l) Dynamic, linear, time invariant, noncausal, stable.
 (m) Static, nonlinear, time invariant, causal, stable.
 (n) Static, linear, time invariant, causal, stable.

2.8

- (a) True. If

$$v_1(n) = T_1[x_1(n)] \text{ and} \\ v_2(n) = T_1[x_2(n)],$$

then

$$\alpha_1 x_1(n) + \alpha_2 x_2(n)$$

yields

$$\alpha_1 v_1(n) + \alpha_2 v_2(n)$$

by the linearity property of T_1 . Similarly, if

$$y_1(n) = T_2[v_1(n)] \text{ and} \\ y_2(n) = T_2[v_2(n)],$$

then

$$\beta_1 v_1(n) + \beta_2 v_2(n) \rightarrow y(n) = \beta_1 y_1(n) + \beta_2 y_2(n)$$

by the linearity property of T_2 . Since

$$v_1(n) = T_1[x_1(n)] \text{ and}$$

$$v_2(n) = \mathcal{T}_2[x_2(n)],$$

it follows that

$$A_1 x_1(n) + A_2 x_2(n)$$

yields the output

$$A_1 \mathcal{T}[x_1(n)] + A_2 \mathcal{T}[x_2(n)],$$

where $\mathcal{T} = \mathcal{T}_1 \mathcal{T}_2$. Hence \mathcal{T} is linear.

(b) True. For \mathcal{T}_1 , if

$$x(n) \rightarrow v(n) \text{ and}$$

$$x(n-k) \rightarrow v(n-k),$$

For \mathcal{T}_2 , if

$$v(n) \rightarrow y(n)$$

$$\text{and } v(n-k) \rightarrow y(n-k).$$

Hence, For $\mathcal{T}_1 \mathcal{T}_2$, if

$$x(n) \rightarrow y(n) \text{ and}$$

$$x(n-k) \rightarrow y(n-k)$$

Therefore, $\mathcal{T} = \mathcal{T}_1 \mathcal{T}_2$ is time invariant.

(c) True. \mathcal{T}_1 is causal $\Rightarrow v(n)$ depends only on $x(k)$ for $k \leq n$. \mathcal{T}_2 is causal $\Rightarrow y(n)$ depends only on $v(k)$ for $k \leq n$. Therefore, $y(n)$ depends only on $x(k)$ for $k \leq n$. Hence, \mathcal{T} is causal.

(d) True. Combine (a) and (b).

(e) True. This follows from $h_1(n) * h_2(n) = h_2(n) * h_1(n)$

(f) False. For example, consider

$$\mathcal{T}_1 : y(n) = nx(n) \text{ and}$$

$$\mathcal{T}_2 : y(n) = nx(n+1).$$

Then,

$$\begin{aligned} \mathcal{T}_2[\mathcal{T}_1[\delta(n)]] &= \mathcal{T}_2(0) = 0. \\ \mathcal{T}_1[\mathcal{T}_2[\delta(n)]] &= \mathcal{T}_1[\delta(n+1)] \\ &= -\delta(n+1) \\ &\neq 0. \end{aligned}$$

(g) False. For example, consider

$$\mathcal{T}_1 : y(n) = x(n) + b \text{ and}$$

$$\mathcal{T}_2 : y(n) = x(n) - b, \text{ where } b \neq 0.$$

Then,

$$\mathcal{T}[x(n)] = \mathcal{T}_2[\mathcal{T}_1[x(n)]] = \mathcal{T}_2[x(n) + b] = x(n).$$

Hence \mathcal{T} is linear.

(h) True.

\mathcal{T}_1 is stable $\Rightarrow v(n)$ is bounded if $x(n)$ is bounded.

\mathcal{T}_2 is stable $\Rightarrow y(n)$ is bounded if $v(n)$ is bounded.

Hence, $y(n)$ is bounded if $x(n)$ is bounded $\Rightarrow T = T_1 T_2$ is stable.

(i) Inverse of (c). T_1 and for T_2 are noncausal $\Rightarrow T$ is noncausal. Example:

$$\begin{aligned} T_1 : y(n) &= x(n+1) \text{ and} \\ T_2 : y(n) &= x(n-2) \\ \Rightarrow T : y(n) &= x(n-1), \end{aligned}$$

which is causal. Hence, the inverse of (c) is false.

Inverse of (h): T_1 and/or T_2 is unstable, implies T is unstable. Example:

$$T_1 : y(n) = e^{x(n)}, \text{ stable and } T_2 : y(n) = \ln[x(n)], \text{ which is unstable.}$$

But $T : y(n) = x(n)$, which is stable. Hence, the inverse of (h) is false.

2.9

(a)

$$\begin{aligned} y(n) &= \sum_{k=-\infty}^n h(k)x(n-k), x(n) = 0, n < 0 \\ y(n+N) &= \sum_{k=-\infty}^{n+N} h(k)x(n+N-k) = \sum_{k=-\infty}^{n+N} h(k)x(n-k) \\ &= \sum_{k=-\infty}^n h(k)x(n-k) + \sum_{k=n+1}^{n+N} h(k)x(n-k) \\ &= y(n) + \sum_{k=n+1}^{n+N} h(k)x(n-k) \end{aligned}$$

For a BIBO system, $\lim_{n \rightarrow \infty} |h(n)| = 0$. Therefore,

$$\begin{aligned} \lim_{n \rightarrow \infty} \sum_{k=n+1}^{n+N} h(k)x(n-k) &= 0 \text{ and} \\ \lim_{n \rightarrow \infty} y(n+N) &= y(N). \end{aligned}$$

(b) Let $x(n) = x_o(n) + au(n)$, where a is a constant and

$$x_o(n) \text{ is a bounded signal with } \lim_{n \rightarrow \infty} x_o(n) = 0.$$

Then,

$$\begin{aligned} y(n) &= a \sum_{k=0}^{\infty} h(k)u(n-k) + \sum_{k=0}^{\infty} h(k)x_o(n-k) \\ &= a \sum_{k=0}^n h(k) + y_o(n) \end{aligned}$$

clearly, $\sum_n x_o^2(n) < \infty \Rightarrow \sum_n y_o^2(n) < \infty$ (from (c) below) Hence,

$$\lim_{n \rightarrow \infty} |y_o(n)| = 0.$$

and, thus, $\lim_{n \rightarrow \infty} y(n) = a \sum_{k=0}^n h(k) = \text{constant}$.
(c)

$$\begin{aligned} y(n) &= \sum_k h(k)x(n-k) \\ \sum_{-\infty}^{\infty} y^2(n) &= \sum_{-\infty}^{\infty} \left[\sum_k h(k)x(n-k) \right]^2 \\ &= \sum_k \sum_l h(k)h(l) \sum_n x(n-k)x(n-l) \end{aligned}$$

But

$$\sum_n x(n-k)x(n-l) \leq \sum_n x^2(n) = E_x.$$

Therefore,

$$\sum_n y^2(n) \leq E_x \sum_k |h(k)| \sum_l |h(l)|.$$

For a BIBO stable system,

$$\sum_k |h(k)| < M.$$

Hence,

$$\begin{aligned} E_y &\leq M^2 E_x, \text{ so that} \\ E_y &< 0 \text{ if } E_x < 0. \end{aligned}$$

2.10

The system is nonlinear. This is evident from observation of the pairs

$$x_3(n) \leftrightarrow y_3(n) \text{ and } x_2(n) \leftrightarrow y_2(n).$$

If the system were linear, $y_2(n)$ would be of the form

$$y_2(n) = \{3, 6, 3\}$$

because the system is time-invariant. However, this is not the case.

2.11

since

$$x_1(n) + x_2(n) = \delta(n)$$

and the system is linear, the impulse response of the system is

$$y_1(n) + y_2(n) = \left\{ 0, \underset{\uparrow}{3}, -1, 2, 1 \right\}.$$

If the system were time invariant, the response to $x_3(n)$ would be

$$\left\{ \underset{\uparrow}{3}, 2, 1, 3, 1 \right\}.$$

But this is not the case.

2.12

- (a) Any weighted linear combination of the signals $x_i(n)$, $i = 1, 2, \dots, N$.
(b) Any $x_i(n - k)$, where k is any integer and $i = 1, 2, \dots, N$.

2.13

A system is BIBO stable if and only if a bounded input produces a bounded output.

$$\begin{aligned}y(n) &= \sum_k h(k)x(n-k) \\|y(n)| &\leq \sum_k |h(k)||x(n-k)| \\&\leq M_x \sum_k |h(k)|\end{aligned}$$

where $|x(n-k)| \leq M_x$. Therefore, $|y(n)| < \infty$ for all n , if and only if

$$\sum_k |h(k)| < \infty.$$

2.14

- (a) A system is causal \Leftrightarrow the output becomes nonzero after the input becomes non-zero. Hence,

$$x(n) = 0 \text{ for } n < n_o \Rightarrow y(n) = 0 \text{ for } n < n_o.$$

- (b)

$$y(n) = \sum_{-\infty}^n h(k)x(n-k), \text{ where } x(n) = 0 \text{ for } n < 0.$$

If $h(k) = 0$ for $k < 0$, then

$$y(n) = \sum_0^n h(k)x(n-k), \text{ and hence, } y(n) = 0 \text{ for } n < 0.$$

On the other hand, if $y(n) = 0$ for $n < 0$, then

$$\sum_{-\infty}^n h(k)x(n-k) \Rightarrow h(k) = 0, k < 0.$$

2.15

- (a)

$$\text{For } a = 1, \sum_{n=M}^N a^n = N - M + 1$$

$$\text{for } a \neq 1, \sum_{n=M}^N a^n = a^M + a^{M+1} + \dots + a^N$$

$$\begin{aligned}(1-a) \sum_{n=M}^N a^n &= a^M + a^{M+1} - a^{M+1} + \dots + a^N - a^N - a^{N+1} \\&= a^M - a^{N+1}\end{aligned}$$

(b) For $M = 0$, $|a| < 1$, and $N \rightarrow \infty$,

$$\sum_{n=0}^{\infty} a^n = \frac{1}{1-a}, |a| < 1.$$

2.16

(a)

$$\begin{aligned} y(n) &= \sum_k h(k)x(n-k) \\ \sum_n y(n) &= \sum_n \sum_k h(k)x(n-k) = \sum_k h(k) \sum_{n=-\infty}^{\infty} x(n-k) \\ &= \left(\sum_k h(k) \right) \left(\sum_n x(n) \right) \end{aligned}$$

(b) (1)

$$\begin{aligned} y(n) &= h(n) * x(n) = \{1, 3, 7, 7, 7, 6, 4\} \\ \sum_n y(n) &= 35, \quad \sum_k h(k) = 5, \quad \sum_k x(k) = 7 \end{aligned}$$

(2)

$$\begin{aligned} y(n) &= \{1, 4, 2, -4, 1\} \\ \sum_n y(n) &= 4, \quad \sum_k h(k) = 2, \quad \sum_k x(k) = 2 \end{aligned}$$

(3)

$$\begin{aligned} y(n) &= \left\{ 0, \frac{1}{2}, -\frac{1}{2}, \frac{3}{2}, -2, 0, -\frac{5}{2}, -2 \right\} \\ \sum_n y(n) &= -5, \quad \sum_n h(n) = 2.5, \quad \sum_n x(n) = -2 \end{aligned}$$

(4)

$$\begin{aligned} y(n) &= \{1, 2, 3, 4, 5\} \\ \sum_n y(n) &= 15, \quad \sum_n h(n) = 1, \quad \sum_n x(n) = 15 \end{aligned}$$

(5)

$$\begin{aligned} y(n) &= \{0, 0, 1, -1, 2, 2, 1, 3\} \\ \sum_n y(n) &= 8, \quad \sum_n h(n) = 4, \quad \sum_n x(n) = 2 \end{aligned}$$

(6)

$$\begin{aligned} y(n) &= \{0, 0, 1, -1, 2, 2, 1, 3\} \\ \sum_n y(n) &= 8, \quad \sum_n h(n) = 2, \quad \sum_n x(n) = 4 \end{aligned}$$

(7)

$$y(n) = \{0, 1, 4, -4, -5, -1, 3\}$$

$$\sum_n y(n) = -2, \quad \sum_n h(n) = -1, \quad \sum_n x(n) = 2$$

(8)

$$y(n) = u(n) + u(n-1) + 2u(n-2)$$

$$\sum_n y(n) = \infty, \quad \sum_n h(n) = \infty, \quad \sum_n x(n) = 4$$

(9)

$$y(n) = \{1, -1, -5, 2, 3, -5, 1, 4\}$$

$$\sum_n y(n) = 0, \quad \sum_n h(n) = 0, \quad \sum_n x(n) = 4$$

(10)

$$y(n) = \{1, 4, 4, 4, 10, 4, 4, 4, 1\}$$

$$\sum_n y(n) = 36, \quad \sum_n h(n) = 6, \quad \sum_n x(n) = 6$$

(11)

$$y(n) = [2(\frac{1}{2})^n - (\frac{1}{4})^n]u(n)$$

$$\sum_n y(n) = \frac{8}{3}, \quad \sum_n h(n) = \frac{4}{3}, \quad \sum_n x(n) = 2$$

2.17

(a)

$$x(n) = \{1, 1, 1, 1\}$$

$$h(n) = \{6, 5, 4, 3, 2, 1\}$$

$$y(n) = \sum_{k=0}^n x(k)h(n-k)$$

$$y(0) = x(0)h(0) = 6,$$

$$y(1) = x(0)h(1) + x(1)h(0) = 11$$

$$y(2) = x(0)h(2) + x(1)h(1) + x(2)h(0) = 15$$

$$y(3) = x(0)h(3) + x(1)h(2) + x(2)h(1) + x(3)h(0) = 18$$

$$y(4) = x(0)h(4) + x(1)h(3) + x(2)h(2) + x(3)h(1) + x(4)h(0) = 14$$

$$y(5) = x(0)h(5) + x(1)h(4) + x(2)h(3) + x(3)h(2) + x(4)h(1) + x(5)h(0) = 10$$

$$y(6) = x(1)h(5) + x(2)h(4) + x(3)h(3) = 6$$

$$y(7) = x(2)h(5) + x(3)h(4) = 3$$

$$y(8) = x(3)h(5) = 1$$

$$y(n) = 0, n \geq 9$$

$$y(n) = \{6, 11, 15, 18, 14, 10, 6, 3, 1\}$$

(b) By following the same procedure as in (a), we obtain

$$y(n) = \left\{ 6, 11, 15, 18, 14, 10, 6, 3, 1 \right\}$$

(c) By following the same procedure as in (a), we obtain

$$y(n) = \left\{ 1, 2, 2, 2, 1 \right\}$$

(d) By following the same procedure as in (a), we obtain

$$y(n) = \left\{ 1, 2, 2, 2, 1 \right\}$$

2.18

(a)

$$\begin{aligned} x(n) &= \left\{ 0, \frac{1}{3}, \frac{2}{3}, 1, \frac{4}{3}, \frac{5}{3}, 2 \right\} \\ h(n) &= \left\{ 1, 1, 1, 1, 1 \right\} \\ y(n) &= x(n) * h(n) \\ &= \left\{ \frac{1}{3}, 1, 2, \frac{10}{3}, 5, \frac{20}{3}, 6, 5, \frac{11}{3}, 2 \right\} \end{aligned}$$

(b)

$$\begin{aligned} x(n) &= \frac{1}{3}n[u(n) - u(n-7)], \\ h(n) &= u(n+2) - u(n-3) \\ y(n) &= x(n) * h(n) \\ &= \frac{1}{3}n[u(n) - u(n-7)] * [u(n+2) - u(n-3)] \\ &= \frac{1}{3}n[u(n) * u(n+2) - u(n) * u(n-3) - u(n-7) * u(n+2) + u(n-7) * u(n-3)] \\ y(n) &= \frac{1}{3}\delta(n+1) + \delta(n) + 2\delta(n-1) + \frac{10}{3}\delta(n-2) + 5\delta(n-3) + \frac{20}{3}\delta(n-4) + 6\delta(n-5) \\ &\quad + 5\delta(n-6) + 5\delta(n-6) + \frac{11}{3}\delta(n-7) + \delta(n-8) \end{aligned}$$

2.19

$$\begin{aligned} y(n) &= \sum_{k=0}^4 h(k)x(n-k), \\ x(n) &= \left\{ \alpha^{-3}, \alpha^{-2}, \alpha^{-1}, 1, \alpha, \dots, \alpha^5 \right\} \\ h(n) &= \left\{ 1, 1, 1, 1, 1 \right\} \end{aligned}$$

$$y(n) = \sum_{k=0}^4 x(n-k), -3 \leq n \leq 9$$

$$= 0, \text{ otherwise.}$$

Therefore,

$$y(-3) = \alpha^{-3},$$

$$y(-2) = x(-3) + x(-2) = \alpha^{-3} + \alpha^{-2},$$

$$y(-1) = \alpha^{-3} + \alpha^{-2} + \alpha^{-1},$$

$$y(0) = \alpha^{-3} + \alpha^{-2} + \alpha^{-1} + 1$$

$$y(1) = \alpha^{-3} + \alpha^{-2} + \alpha^{-1} + 1 + \alpha,$$

$$y(2) = \alpha^{-3} + \alpha^{-2} + \alpha^{-1} + 1 + \alpha + \alpha^2$$

$$y(3) = \alpha^{-1} + 1 + \alpha + \alpha^2 + \alpha^3,$$

$$y(4) = \alpha^4 + \alpha^3 + \alpha^2 + \alpha + 1$$

$$y(5) = \alpha + \alpha^2 + \alpha^3 + \alpha^4 + \alpha^5,$$

$$y(6) = \alpha^2 + \alpha^3 + \alpha^4 + \alpha^5$$

$$y(7) = \alpha^3 + \alpha^4 + \alpha^5,$$

$$y(8) = \alpha^4 + \alpha^5,$$

$$y(9) = \alpha^5$$

2.20

- (a) $131 \times 122 = 15982$
 (b) $\{1_{\uparrow}, 3, 1\} * \{1_{\uparrow}, 2, 2\} = \{1, 5, 9, 8, 2\}$
 (c) $(1 + 3z + z^2)(1 + 2z + 2z^2) = 1 + 5z + 9z^2 + 8z^3 + 2z^4$
 (d) $1.31 \times 12.2 = 15.982$.
 (e) These are different ways to perform convolution.

2.21

(a)

$$y(n) = \sum_{k=0}^n a^k u(k) b^{n-k} u(n-k) = b^n \sum_{k=0}^n (ab^{-1})^k$$

$$y(n) = \begin{cases} \frac{b^{n+1} - a^{n+1}}{b-a} u(n), & a \neq b \\ b^n (n+1) u(n), & a = b \end{cases}$$

(b)

$$x(n) = \{1, 2, 1, 1\}$$

$$h(n) = \{1, -1, 0, 0, 1, 1\}$$

$$y(n) = \{1, 1, -1, 0, 0, 3, 3, 2, 1\}$$

(c)

$$\begin{aligned}x(n) &= \left\{ 1, \underset{\uparrow}{1}, 1, 1, 1, 0, -1 \right\}, \\h(n) &= \left\{ 1, 2, \underset{\uparrow}{3}, 2, 1 \right\} \\y(n) &= \left\{ 1, 3, 6, \underset{\uparrow}{8}, 9, 8, 5, 1, -2, -2, -1 \right\}\end{aligned}$$

(d)

$$\begin{aligned}x(n) &= \left\{ \underset{\uparrow}{1}, 1, 1, 1, 1 \right\}, \\h'(n) &= \left\{ \underset{\uparrow}{0}, 0, 1, 1, 1, 1, 1 \right\} \\h(n) &= h'(n) + h'(n-9), \\y(n) &= y'(n) + y'(n-9), \text{ where} \\y'(n) &= \left\{ \underset{\uparrow}{0}, 0, 1, 2, 3, 4, 5, 5, 4, 3, 2, 1 \right\}\end{aligned}$$

2.22

(a)

$$\begin{aligned}y_i(n) &= x(n) * h_i(n) \\y_1(n) &= x(n) + x(n-1) \\&= \{1, 5, 6, 5, 8, 8, 6, 7, 9, 12, 12, 15, 9\}, \text{ similarly} \\y_2(n) &= \{1, 6, 11, 11, 13, 16, 14, 13, 15, 21, 25, 28, 24, 9\} \\y_3(n) &= \{0.5, 2.5, 3, 2.5, 4, 4, 3, 3.5, 4.5, 6, 6, 7.5, 4.5\} \\y_4(n) &= \{0.25, 1.5, 2.75, 2.75, 3.25, 4, 3.5, 3.25, 3.75, 5.25, 6.25, 7, 6, 2.25\} \\y_5(n) &= \{0.25, 0.5, -1.25, 0.75, 0.25, -1, 0.5, 0.25, 0, 0.25, -0.75, 1, -3, -2.25\}\end{aligned}$$

(b)

$$\begin{aligned}y_3(n) &= \frac{1}{2}y_1(n), \text{ because} \\h_3(n) &= \frac{1}{2}h_1(n) \\y_4(n) &= \frac{1}{4}y_2(n), \text{ because} \\h_4(n) &= \frac{1}{4}h_2(n)\end{aligned}$$

(c) $y_2(n)$ and $y_4(n)$ are smoother than $y_1(n)$, but $y_4(n)$ will appear even smoother because of the smaller scale factor.

(d) System 4 results in a smoother output. The negative value of $h_5(0)$ is responsible for the non-smooth characteristics of $y_5(n)$

(e)

$$y_6(n) = \left\{ \frac{1}{2}, \frac{3}{2}, -1, \frac{1}{2}, 1, -1, 0, \frac{1}{2}, \frac{1}{2}, 1, -\frac{1}{2}, \frac{3}{2}, -\frac{9}{2} \right\}$$

$y_2(n)$ is smoother than $y_6(n)$.

2.23

If

$$\begin{aligned}y_1(n) &= ny_1(n-1) + x_1(n) \text{ and} \\y_2(n) &= ny_2(n-1) + x_2(n) \text{ then} \\x(n) &= ax_1(n) + bx_2(n)\end{aligned}$$

produces the output

$$\begin{aligned}y(n) &= ny(n-1) + x(n), \text{ where} \\y(n) &= ay_1(n) + by_2(n).\end{aligned}$$

Hence, the system is linear. If the input is $x(n-1)$, we have

$$\begin{aligned}y(n-1) &= (n-1)y(n-2) + x(n-1). \text{ But} \\y(n-1) &= ny(n-2) + x(n-1).\end{aligned}$$

Hence, the system is time variant. If $x(n) = u(n)$, then $|x(n)| \leq 1$. But for this bounded input, the output is

$$y(0) = 1, \quad y(1) = 1 + 1 = 2, \quad y(2) = 2 \times 2 + 1 = 5, \dots$$

which is unbounded. Hence, the system is unstable.

2.24

(a)

$$\begin{aligned}\delta(n) &= \gamma(n) - a\gamma(n-1) \text{ and,} \\ \delta(n-k) &= \gamma(n-k) - a\gamma(n-k-1). \text{ Then,} \\ x(n) &= \sum_{k=-\infty}^{\infty} x(k)\delta(n-k) \\ &= \sum_{k=-\infty}^{\infty} x(k)[\gamma(n-k) - a\gamma(n-k-1)] \\ x(n) &= \sum_{k=-\infty}^{\infty} x(k)\gamma(n-k) - a \sum_{k=-\infty}^{\infty} x(k)\gamma(n-k-1) \\ x(n) &= \sum_{k=-\infty}^{\infty} x(k)\gamma(n-k) - a \sum_{k=-\infty}^{\infty} x(k-1)\gamma(n-k) \\ &= \sum_{k=-\infty}^{\infty} [x(k) - ax(k-1)]\gamma(n-k) \\ \text{Thus, } c_k &= x(k) - ax(k-1)\end{aligned}$$

(b)

$$\begin{aligned}y(n) &= \mathcal{T}[x(n)] \\ &= \mathcal{T}\left[\sum_{k=-\infty}^{\infty} c_k\gamma(n-k)\right] \\ &= \sum_{k=-\infty}^{\infty} c_k\mathcal{T}[\gamma(n-k)] \\ &= \sum_{k=-\infty}^{\infty} c_k g(n-k)\end{aligned}$$

(c)

$$\begin{aligned}h(n) &= T[\delta(n)] \\ &= T[\gamma(n) - a\gamma(n-1)] \\ &= g(n) - ag(n-1)\end{aligned}$$

2.25

With $x(n) = 0$, we have

$$\begin{aligned}y(n-1) + \frac{4}{3}y(n-1) &= 0 \\ y(-1) &= -\frac{4}{3}y(-2) \\ y(0) &= \left(-\frac{4}{3}\right)^2 y(-2) \\ y(1) &= \left(-\frac{4}{3}\right)^3 y(-2) \\ &\vdots \\ y(k) &= \left(-\frac{4}{3}\right)^{k+2} y(-2) \leftarrow \text{zero-input response.}\end{aligned}$$

2.26

Consider the homogeneous equation:

$$y(n) - \frac{5}{6}y(n-1) + \frac{1}{6}y(n-2) = 0.$$

The characteristic equation is

$$\lambda^2 - \frac{5}{6}\lambda + \frac{1}{6} = 0. \lambda = \frac{1}{2}, \frac{1}{3}.$$

Hence,

$$y_h(n) = c_1\left(\frac{1}{2}\right)^n + c_2\left(\frac{1}{3}\right)^n$$

The particular solution to

$$\begin{aligned}x(n) &= 2^n u(n) \text{ is} \\ y_p(n) &= k(2^n)u(n).\end{aligned}$$

Substitute this solution into the difference equation. Then, we obtain

$$k(2^n)u(n) - k\left(\frac{5}{6}\right)(2^{n-1})u(n-1) + k\left(\frac{1}{6}\right)(2^{n-2})u(n-2) = 2^n u(n)$$

For $n = 2$,

$$4k - \frac{5k}{3} + \frac{k}{6} = 4 \Rightarrow k = \frac{8}{5}.$$

Therefore, the total solution is

$$y(n) = y_p(n) + y_h(n) = \frac{8}{5}(2^n)u(n) + c_1\left(\frac{1}{2}\right)^n u(n) + c_2\left(\frac{1}{3}\right)^n u(n).$$

To determine c_1 and c_2 , assume that $y(-2) = y(-1) = 0$. Then,

$$y(0) = 1 \text{ and}$$

$$y(1) = \frac{5}{6}y(0) + 2 = \frac{17}{6}$$

Thus,

$$\begin{aligned} \frac{8}{5} + c_1 + c_2 &= 1 \Rightarrow c_1 + c_2 = -\frac{3}{5} \\ \frac{16}{5} + \frac{1}{2}c_1 + \frac{1}{3}c_2 &= \frac{17}{6} \Rightarrow 3c_1 + 2c_2 = -\frac{11}{5} \end{aligned}$$

and, therefore,

$$c_1 = -1, c_2 = \frac{2}{5}.$$

The total solution is

$$y(n) = \left[\frac{8}{5}(2)^n - \left(\frac{1}{2}\right)^n + \frac{2}{5}\left(\frac{1}{3}\right)^n \right] u(n)$$

2.27

$$y(n) - 3y(n-1) - 4y(n-2) = x(n) + 2x(n-1)$$

The characteristic equation is

$$\lambda^2 - 3\lambda - 4 = 0.$$

Hence, $\lambda = 4, -1$ and

$$y_h(n) = c_1(n)4^n + c_2(-1)^n.$$

Since 4 is a characteristic root and the excitation is

$$x(n) = 4^n u(n),$$

we assume a particular solution of the form

$$y_p(n) = kn4^n u(n).$$

Then

$$\begin{aligned} kn4^n u(n) - 3k(n-1)4^{n-1}u(n-1) - 4k(n-2)4^{n-2}u(n-2) \\ = 4^n u(n) + 2(4)^{n-1}u(n-1) \end{aligned}$$

For $n = 2$,

$$k(32 - 12) = 4^2 + 8 = 24 \rightarrow k = \frac{6}{5}.$$

The total solution is

$$\begin{aligned} y(n) &= y_p(n) + y_h(n) \\ &= \left[\frac{6}{5}n4^n + c_1 4^n + c_2(-1)^n \right] u(n) \end{aligned}$$

To solve for c_1 and c_2 , we assume that $y(-1) = y(-2) = 0$. Then,

$$y(0) = 1 \text{ and}$$

$$y(1) = 3y(0) + 4 + 2 = 9$$

Hence,

$$c_1 + c_2 = 1 \text{ and}$$

$$\begin{aligned}\frac{24}{5} + 4c_1 - c_2 &= 9 \\ 4c_1 - c_2 &= \frac{21}{5}\end{aligned}$$

Therefore,

$$c_1 = \frac{26}{25} \text{ and } c_2 = -\frac{1}{25}$$

The total solution is

$$y(n) = \left[\frac{6}{5}n4^n + \frac{26}{25}4^n - \frac{1}{25}(-1)^n \right] u(n)$$

2.28

From 2.27, the characteristic values are $\lambda = 4, -1$. Hence

$$y_h(n) = c_1 4^n + c_2 (-1)^n$$

When $x(n) = \delta(N)$, we find that

$$\begin{aligned}y(0) &= 1 \text{ and} \\ y(1) - 3y(0) &= 2 \text{ or} \\ y(1) &= 5.\end{aligned}$$

Hence,

$$c_1 + c_2 = 1 \text{ and } 4c_1 - c_2 = 5$$

This yields, $c_1 = \frac{6}{5}$ and $c_2 = -\frac{1}{5}$. Therefore,

$$h(n) = \left[\frac{6}{5}4^n - \frac{1}{5}(-1)^n \right] u(n)$$

2.29

(a) $L_1 = N_1 + M_1$ and $L_2 = N_2 + M_2$

(b) Partial overlap from left:

$$\text{low } N_1 + M_1 \quad \text{high } N_1 + M_2 - 1$$

$$\text{Full overlap: low } N_1 + M_2 \quad \text{high } N_2 + M_1$$

Partial overlap from right:

$$\text{low } N_2 + M_1 + 1 \quad \text{high } N_2 + M_2$$

(c)

$$x(n) = \left\{ 1, 1, \underset{\uparrow}{1}, 1, 1, 1, 1 \right\}$$

$$h(n) = \left\{ 2, 2, \underset{\uparrow}{2}, 2, 2 \right\}$$

$$N_1 = -2,$$

$$N_2 = 4,$$

$$M_1 = -1,$$

$$M_2 = 2,$$

$$\text{Partial overlap from left: } n = -3 \quad n = -1 \quad L_1 = -3$$

$$\text{Full overlap: } n = 0 \quad n = 3$$

$$\text{Partial overlap from right: } n = 4 \quad n = 6 \quad L_2 = 6$$

2.30

(a)

$$y(n) - 0.6y(n-1) + 0.08y(n-2) = x(n).$$

The characteristic equation is

$$\lambda^2 - 0.6\lambda + 0.08 = 0.$$

$\lambda = 0.2, 0.4$ Hence,

$$y_h(n) = c_1 \frac{1^n}{5} + c_2 \frac{2^n}{5}.$$

With $x(n) = \delta(n)$, the initial conditions are

$$y(0) = 1,$$

$$y(1) - 0.6y(0) = 0 \Rightarrow y(1) = 0.6.$$

$$\text{Hence, } c_1 + c_2 = 1 \text{ and}$$

$$\frac{1}{5}c_1 + \frac{2}{5} = 0.6 \Rightarrow c_1 = -1, c_2 = 3.$$

$$\text{Therefore } h(n) = \left[-\left(\frac{1}{5}\right)^n + 2\left(\frac{2}{5}\right)^n \right] u(n)$$

The step response is

$$\begin{aligned} s(n) &= \sum_{k=0}^n h(n-k), n \geq 0 \\ &= \sum_{k=0}^n \left[2\left(\frac{2}{5}\right)^{n-k} - \left(\frac{1}{5}\right)^{n-k} \right] \\ &= \left\{ \frac{1}{0.12} \left[\left(\frac{2}{5}\right)^{n+1} - 1 \right] - \frac{1}{0.16} \left[\left(\frac{1}{5}\right)^{n+1} - 1 \right] \right\} u(n) \end{aligned}$$

(b)

$$y(n) - 0.7y(n-1) + 0.1y(n-2) = 2x(n) - x(n-2).$$

The characteristic equation is

$$\lambda^2 - 0.7\lambda + 0.1 = 0.$$

$\lambda = \frac{1}{2}, \frac{1}{5}$ Hence,

$$y_h(n) = c_1 \frac{1^n}{2} + c_2 \frac{1^n}{5}.$$

With $x(n) = \delta(n)$, we have

$$y(0) = 2,$$

$$y(1) - 0.7y(0) = 0 \Rightarrow y(1) = 1.4.$$

$$\text{Hence, } c_1 + c_2 = 2 \text{ and}$$

$$\frac{1}{2}c_1 + \frac{1}{5} = 1.4 = \frac{7}{5}$$

$$\Rightarrow c_1 + \frac{2}{5}c_2 = \frac{14}{5}.$$

These equations yield

$$c_1 = \frac{10}{3}, c_2 = -\frac{4}{3}.$$

$$h(n) = \left[\frac{10}{3}\left(\frac{1}{2}\right)^n - \frac{4}{3}\left(\frac{1}{5}\right)^n \right] u(n)$$

The step response is

$$\begin{aligned}
 s(n) &= \sum_{k=0}^n h(n-k), \\
 &= \frac{10}{3} \sum_{k=0}^n \left(\frac{1}{2}\right)^{n-k} - \frac{4}{3} \sum_{k=0}^n \left(\frac{1}{5}\right)^{n-k} \\
 &= \frac{10}{3} \left(\frac{1}{2}\right)^n \sum_{k=0}^n 2^k - \frac{4}{3} \left(\frac{1}{5}\right)^n \sum_{k=0}^n 5^k \\
 &= \frac{10}{3} \left(\frac{1}{2}\right)^n (2^{n+1} - 1)u(n) - \frac{4}{3} \left(\frac{1}{5}\right)^n (5^{n+1} - 1)u(n)
 \end{aligned}$$

2.31

$$\begin{aligned}
 h(n) &= \left\{ \frac{1}{1}, \frac{1}{2}, \frac{1}{4}, \frac{1}{8}, \frac{1}{16} \right\} \\
 y(n) &= \left\{ \underset{\uparrow}{1}, 2, 2.5, 3, 3, 3, 2, 1, 0 \right\} \\
 x(0)h(0) &= y(0) \Rightarrow x(0) = 1 \\
 \frac{1}{2}x(0) + x(1) &= y(1) \Rightarrow x(1) = \frac{3}{2}
 \end{aligned}$$

By continuing this process, we obtain

$$x(n) = \left\{ 1, \frac{3}{2}, \frac{3}{2}, \frac{7}{4}, \frac{3}{2}, \dots \right\}$$

2.32

(a) $h(n) = h_1(n) * [h_2(n) - h_3(n) * h_4(n)]$

(b)

$$\begin{aligned}
 h_3(n) * h_4(n) &= (n-1)u(n-2) \\
 h_2(n) - h_3(n) * h_4(n) &= 2u(n) - \delta(n) \\
 h_1(n) &= \frac{1}{2}\delta(n) + \frac{1}{4}\delta(n-1) + \frac{1}{2}\delta(n-2) \\
 \text{Hence } h(n) &= \left[\frac{1}{2}\delta(n) + \frac{1}{4}\delta(n-1) + \frac{1}{2}\delta(n-2) \right] * [2u(n) - \delta(n)] \\
 &= \frac{1}{2}\delta(n) + \frac{5}{4}\delta(n-1) + 2\delta(n-2) + \frac{5}{2}u(n-3)
 \end{aligned}$$

(c)

$$\begin{aligned}
 x(n) &= \left\{ 1, 0, \underset{\uparrow}{0}, 3, 0, -4 \right\} \\
 y(n) &= \left\{ \frac{1}{2}, \frac{5}{4}, \underset{\uparrow}{2}, \frac{25}{4}, \frac{13}{2}, 5, 2, 0, 0, \dots \right\}
 \end{aligned}$$

2.33

First, we determine

$$\begin{aligned}
 s(n) &= u(n) * h(n) \\
 s(n) &= \sum_{k=0}^{\infty} u(k)h(n-k) \\
 &= \sum_{k=0}^n h(n-k) \\
 &= \sum_{k=0}^{\infty} a^{n-k} \\
 &= \frac{a^{n+1} - 1}{a - 1}, n \geq 0
 \end{aligned}$$

For $x(n) = u(n+5) - u(n-10)$, we have the response

$$s(n+5) - s(n-10) = \frac{a^{n+6} - 1}{a - 1} u(n+5) - \frac{a^{n-9} - 1}{a - 1} u(n-10)$$

From figure P2.33,

$$\begin{aligned}
 y(n) &= x(n) * h(n) - x(n) * h(n-2) \\
 \text{Hence, } y(n) &= \frac{a^{n+6} - 1}{a - 1} u(n+5) - \frac{a^{n-9} - 1}{a - 1} u(n-10) \\
 &\quad - \frac{a^{n+4} - 1}{a - 1} u(n+3) + \frac{a^{n-11} - 1}{a - 1} u(n-12)
 \end{aligned}$$

2.34

$$\begin{aligned}
 h(n) &= [u(n) - u(n-M)] / M \\
 s(n) &= \sum_{k=-\infty}^{\infty} u(k)h(n-k) \\
 &= \sum_{k=0}^n h(n-k) = \begin{cases} \frac{n+1}{M}, & n < M \\ 1, & n \geq M \end{cases}
 \end{aligned}$$

2.35

$$\begin{aligned}
 \sum_{n=-\infty}^{\infty} |h(n)| &= \sum_{n=0, n \text{ even}}^{\infty} |a|^n \\
 &= \sum_{n=0}^{\infty} |a|^{2n} \\
 &= \frac{1}{1 - |a|^2}
 \end{aligned}$$

Stable if $|a| < 1$

2.36

$h(n) = a^n u(n)$. The response to $u(n)$ is

$$\begin{aligned}y_1(n) &= \sum_{k=0}^{\infty} u(k)h(n-k) \\&= \sum_{k=0}^n a^{n-k} \\&= a^n \sum_{k=0}^n a^{-k} \\&= \frac{1-a^{n+1}}{1-a} u(n) \\ \text{Then, } y(n) &= y_1(n) - y_1(n-10) \\&= \frac{1}{1-a} [(1-a^{n+1})u(n) - (1-a^{n-9})u(n-10)]\end{aligned}$$

2.37

We may use the result in problem 2.36 with $a = \frac{1}{2}$. Thus,

$$y(n) = 2 \left[1 - \left(\frac{1}{2}\right)^{n+1} \right] u(n) - 2 \left[1 - \left(\frac{1}{2}\right)^{n-9} \right] u(n-10)$$

2.38

(a)

$$\begin{aligned}y(n) &= \sum_{k=-\infty}^{\infty} h(k)x(n-k) \\&= \sum_{k=0}^n \left(\frac{1}{2}\right)^k 2^{n-k} \\&= 2^n \sum_{k=0}^n \left(\frac{1}{4}\right)^k \\&= 2^n \left[1 - \left(\frac{1}{4}\right)^{n+1} \right] \left(\frac{4}{3}\right) \\&= \frac{2}{3} \left[2^{n+1} - \left(\frac{1}{2}\right)^{n+1} \right] u(n)\end{aligned}$$

(b)

$$\begin{aligned}y(n) &= \sum_{k=-\infty}^{\infty} h(k)x(n-k) \\&= \sum_{k=0}^{\infty} h(k) \\&= \sum_{k=0}^{\infty} \left(\frac{1}{2}\right)^k = 2, n < 0\end{aligned}$$

$$\begin{aligned}
y(n) &= \sum_{k=n}^{\infty} h(k) \\
&= \sum_{k=n}^{\infty} \left(\frac{1}{2}\right)^k \\
&= \sum_{k=0}^{\infty} \left(\frac{1}{2}\right)^k - \sum_{k=0}^{n-1} \left(\frac{1}{2}\right)^k \\
&= 2 - \left(\frac{1 - \left(\frac{1}{2}\right)^n}{\frac{1}{2}}\right) \\
&= 2\left(\frac{1}{2}\right)^n, n \geq 0.
\end{aligned}$$

2.39

(a)

$$\begin{aligned}
h_e(n) &= h_1(n) * h_2(n) * h_3(n) \\
&= [\delta(n) - \delta(n-1)] * u(n) * h(n) \\
&= [u(n) - u(n-1)] * h(n) \\
&= \delta(n) * h(n) \\
&= h(n)
\end{aligned}$$

(b) No.

2.40

(a) $x(n)\delta(n - n_0) = x(n_0)$. Thus, only the value of $x(n)$ at $n = n_0$ is of interest.
 $x(n) * \delta(n - n_0) = x(n - n_0)$. Thus, we obtain the shifted version of the sequence $x(n)$.

(b)

$$\begin{aligned}
y(n) &= \sum_{k=-\infty}^{\infty} h(k)x(n-k) \\
&= h(n) * x(n) \\
\text{Linearity: } x_1(n) \rightarrow y_1(n) &= h(n) * x_1(n) \\
x_2(n) \rightarrow y_2(n) &= h(n) * x_2(n) \\
\text{Then } x(n) &= \alpha x_1(n) + \beta x_2(n) \rightarrow y(n) = h(n) * x(n) \\
y(n) &= h(n) * [\alpha x_1(n) + \beta x_2(n)] \\
&= \alpha h(n) * x_1(n) + \beta h(n) * x_2(n) \\
&= \alpha y_1(n) + \beta y_2(n)
\end{aligned}$$

Time Invariance:

$$\begin{aligned}
x(n) \rightarrow y(n) &= h(n) * x(n) \\
x(n - n_0) \rightarrow y_1(n) &= h(n) * x(n - n_0) \\
&= \sum_k h(k)x(n - n_0 - k) \\
&= y(n - n_0)
\end{aligned}$$

(c) $h(n) = \delta(n - n_0)$.

2.41

- (a) $s(n) = -a_1s(n-1) - a_2s(n-2) - \dots - a_Ns(n-N) + b_0v(n)$. Refer to fig 2.2.
 (b) $v(n) = \frac{1}{b_0} [s(n) + a_1s(n-1) + a_2s(n-2) + \dots + a_Ns(n-N)]$. Refer to fig 2.3

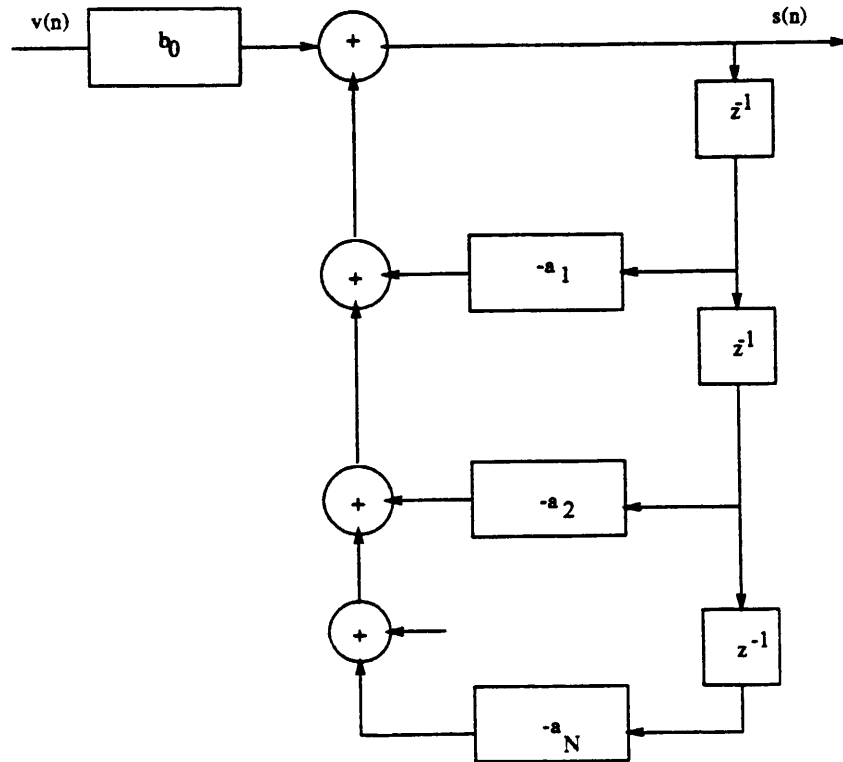

Figure 2.2:

2.42

$$\begin{aligned}
 y(n) &= -\frac{1}{2}y(n-1) + x(n) + 2x(n-2) \\
 y(-2) &= -\frac{1}{2}y(-3) + x(-2) + 2x(-4) = 1 \\
 y(-1) &= -\frac{1}{2}y(-2) + x(-1) + 2x(-3) = \frac{3}{2} \\
 y(0) &= -\frac{1}{2}y(-1) + 2x(-2) + x(0) = \frac{17}{4} \\
 y(1) &= -\frac{1}{2}y(0) + x(1) + 2x(-1) = \frac{47}{8}, \text{ etc}
 \end{aligned}$$

2.43

- (a) Refer to fig 2.4
 (b) Refer to fig 2.5

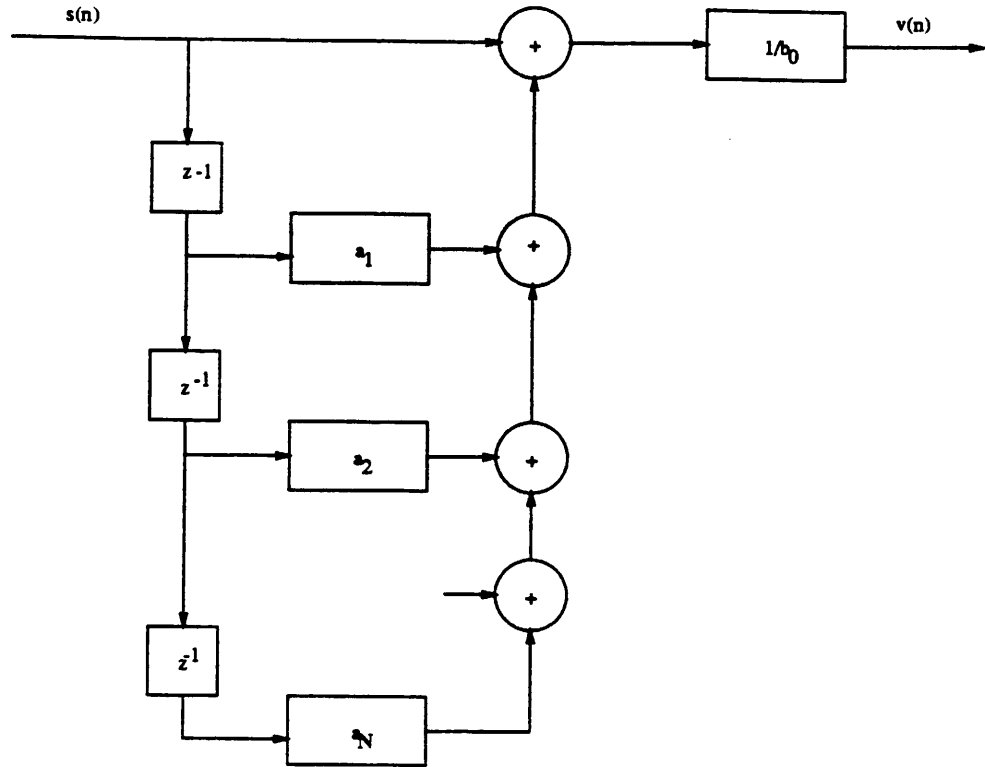

Figure 2.3:

2.44

(a)

$$\begin{aligned}
 x(n) &= \left\{ \underset{\uparrow}{1}, 0, 0, \dots \right\} \\
 y(n) &= \frac{1}{2}y(n-1) + x(n) + x(n-1) \\
 y(0) &= x(0) = 1, \\
 y(1) &= \frac{1}{2}y(0) + x(1) + x(0) = \frac{3}{2} \\
 y(2) &= \frac{1}{2}y(1) + x(2) + x(1) = \frac{3}{4}. \text{ Thus, we obtain} \\
 y(n) &= \left\{ 1, \frac{3}{2}, \frac{3}{4}, \frac{3}{8}, \frac{3}{16}, \frac{3}{32}, \dots \right\}
 \end{aligned}$$

(b) $y(n) = \frac{1}{2}y(n-1) + x(n) + x(n-1)$

(c) As in part(a), we obtain

$$y(n) = \left\{ 1, \frac{5}{2}, \frac{13}{4}, \frac{29}{8}, \frac{61}{16}, \dots \right\}$$

(d)

$$\begin{aligned}
 y(n) &= u(n) * h(n) \\
 &= \sum_k u(k)h(n-k)
 \end{aligned}$$

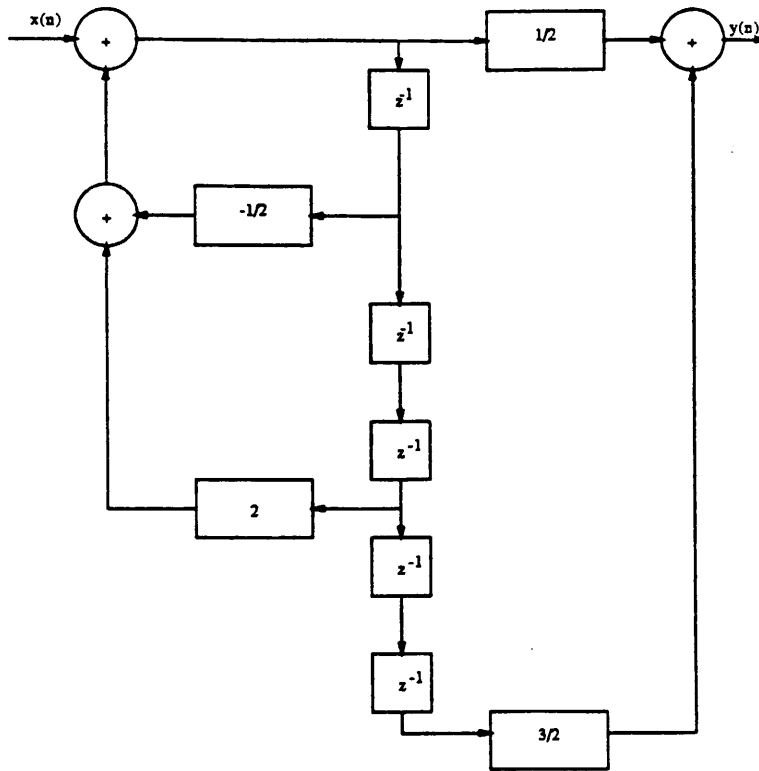

Figure 2.4:

$$\begin{aligned}
 &= \sum_{k=0}^n h(n-k) \\
 y(0) &= h(0) = 1 \\
 y(1) &= h(0) + h(1) = \frac{5}{2} \\
 y(2) &= h(0) + h(1) + h(2) = \frac{13}{4}, \text{ etc}
 \end{aligned}$$

(e) from part(a), $h(n) = 0$ for $n < 0 \Rightarrow$ the system is causal.

$$\sum_{n=0}^{\infty} |h(n)| = 1 + \frac{3}{2} \left(1 + \frac{1}{2} + \frac{1}{4} + \dots \right) = 4 \Rightarrow \text{system is stable}$$

2.45

(a)

$$\begin{aligned}
 y(n) &= ay(n-1) + bx(n) \\
 \Rightarrow h(n) &= ba^n u(n) \\
 \sum_{n=0}^{\infty} h(n) &= \frac{b}{1-a} = 1 \\
 \Rightarrow b &= 1-a.
 \end{aligned}$$

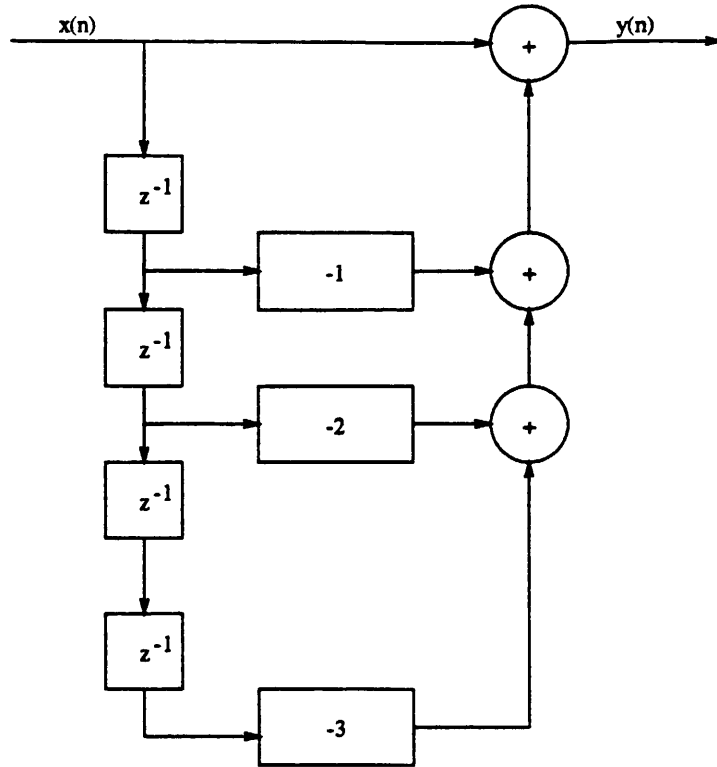

Figure 2.5:

(a)

$$\begin{aligned}
 s(n) &= \sum_{k=0}^n h(n-k) \\
 &= b \left[\frac{1-a^{n+1}}{1-a} \right] u(n) \\
 s(\infty) &= \frac{b}{1-a} = 1 \\
 \Rightarrow b &= 1-a.
 \end{aligned}$$

(c) $b = 1 - a$ in both cases.

2.46

(a)

$$\begin{aligned}
 y(n) &= 0.8y(n-1) + 2x(n) + 3x(n-1) \\
 y(n) - 0.8y(n-1) &= 2x(n) + 3x(n-1)
 \end{aligned}$$

The characteristic equation is

$$\begin{aligned}
 \lambda - 0.8 &= 0 \\
 \lambda &= 0.8. \\
 y_h(n) &= c(0.8)^n
 \end{aligned}$$

Let us first consider the response of the system

$$y(n) - 0.8y(n-1) = x(n)$$

to $x(n) = \delta(n)$. Since $y(0) = 1$, it follows that $c = 1$. Then, the impulse response of the original system is

$$\begin{aligned} h(n) &= 2(0.8)^n u(n) + 3(0.8)^{n-1} u(n-1) \\ &= 2\delta(n) + 4.6(0.8)^{n-1} u(n-1) \end{aligned}$$

(b) The inverse system is characterized by the difference equation

$$x(n) = -1.5x(n-1) + \frac{1}{2}y(n) - 0.4y(n-1)$$

Refer to fig 2.6

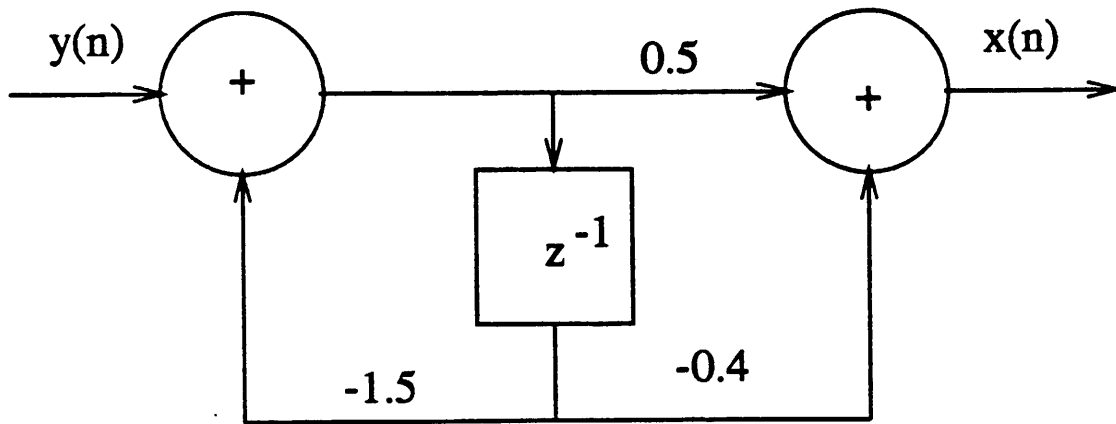

Figure 2.6:

2.47

$$y(n) = 0.9y(n-1) + x(n) + 2x(n-1) + 3x(n-2)$$

(a) For $x(n) = \delta(n)$, we have

$$\begin{aligned} y(0) &= 1, \\ y(1) &= 2.9, \\ y(2) &= 5.61, \\ y(3) &= 5.049, \\ y(4) &= 4.544, \\ y(5) &= 4.090, \dots \end{aligned}$$

(b)

$$\begin{aligned}s(0) &= y(0) = 1, \\s(1) &= y(0) + y(1) = 3.91 \\s(2) &= y(0) + y(1) + y(2) = 9.51 \\s(3) &= y(0) + y(1) + y(2) + y(3) = 14.56 \\s(4) &= \sum_0^4 y(n) = 19.10 \\s(5) &= \sum_0^5 y(n) = 23.19\end{aligned}$$

(c)

$$\begin{aligned}h(n) &= (0.9)^n u(n) + 2(0.9)^{n-1} u(n-1) + 3(0.9)^{n-2} u(n-2) \\&= \delta(n) + 2.9\delta(n-1) + 5.61(0.9)^{n-2} u(n-2)\end{aligned}$$

2.48

(a)

$$\begin{aligned}y(n) &= \frac{1}{3}x(n) + \frac{1}{3}x(n-3) + y(n-1) \\ \text{for } x(n) &= \delta(n), \text{ we have} \\ h(n) &= \left\{ \frac{1}{3}, \frac{1}{3}, \frac{1}{3}, \frac{2}{3}, \frac{2}{3}, \frac{2}{3}, \frac{2}{3}, \dots \right\}\end{aligned}$$

(b)

$$\begin{aligned}y(n) &= \frac{1}{2}y(n-1) + \frac{1}{8}y(n-2) + \frac{1}{2}x(n-2) \\ \text{with } x(n) &= \delta(n), \text{ and} \\ y(-1) &= y(-2) = 0, \text{ we obtain} \\ h(n) &= \left\{ 0, 0, \frac{1}{2}, \frac{1}{4}, \frac{3}{16}, \frac{1}{8}, \frac{11}{128}, \frac{15}{256}, \frac{41}{1024}, \dots \right\}\end{aligned}$$

(c)

$$\begin{aligned}y(n) &= 1.4y(n-1) - 0.48y(n-2) + x(n) \\ \text{with } x(n) &= \delta(n), \text{ and} \\ y(-1) &= y(-2) = 0, \text{ we obtain} \\ h(n) &= \{1, 1.4, 1.48, 1.4, 1.2496, 1.0774, 0.9086, \dots\}\end{aligned}$$

(d) All three systems are IIR.

(e)

$$y(n) = 1.4y(n-1) - 0.48y(n-2) + x(n)$$

The characteristic equation is

$$\lambda^2 - 1.4\lambda + 0.48 = 0 \text{ Hence}$$

$$\lambda = 0.8, 0.6 \text{ and}$$

$$y_h(n) = c_1(0.8)^n + c_2(0.6)^n \text{ For } x(n) = \delta(n). \text{ We have,}$$

$$\begin{aligned}
c_1 + c_2 &= 1 \text{ and} \\
0.8c_1 + 0.6c_2 &= 1.4 \\
\Rightarrow c_1 &= 4, \\
c_2 &= -3. \text{ Therefore} \\
h(n) &= [4(0.8)^n - 3(0.6)^n] u(n)
\end{aligned}$$

2.49

(a)

$$\begin{aligned}
h_1(n) &= c_0\delta(n) + c_1\delta(n-1) + c_2\delta(n-2) \\
h_2(n) &= b_2\delta(n) + b_1\delta(n-1) + b_0\delta(n-2) \\
h_3(n) &= a_0\delta(n) + (a_1 + a_0a_2)\delta(n-1) + a_1a_2\delta(n-2)
\end{aligned}$$

(b) The only question is whether

$$\begin{aligned}
h_3(n) &\stackrel{?}{=} h_2(n) = h_1(n) \\
\text{Let } a_0 &= c_0, \\
a_1 + a_2c_0 &= c_1, \\
a_2a_1 &= c_2. \text{ Hence} \\
\frac{c_2}{a_2} + a_2c_0 - c_1 &= 0 \\
\Rightarrow c_0a_2^2 - c_1a_2 + c_2 &= 0
\end{aligned}$$

For $c_0 \neq 0$, the quadratic has a real solution if and only if

$$c_1^2 - 4c_0c_2 \geq 0$$

2.50

(a)

$$\begin{aligned}
y(n) &= \frac{1}{2}y(n-1) + x(n) + x(n-1) \\
\text{For } y(n) - \frac{1}{2}y(n-1) &= \delta(n), \text{ the solution is} \\
h(n) &= \left(\frac{1}{2}\right)^n u(n) + \left(\frac{1}{2}\right)^{n-1} u(n-1)
\end{aligned}$$

$$(b) h_1(n) * [\delta(n) + \delta(n-1)] = \left(\frac{1}{2}\right)^n u(n) + \left(\frac{1}{2}\right)^{n-1} u(n-1).$$

2.51

(a)

$$\begin{aligned}
\text{convolution: } y_1(n) &= \left\{ \underset{\uparrow}{1}, 3, 7, 7, 7, 6, 4 \right\} \\
\text{correlation: } \gamma_1(n) &= \left\{ 1, 3, 7, 7, \underset{\uparrow}{7}, 6, 4 \right\}
\end{aligned}$$

(b)

$$\begin{aligned}\text{convolution: } y_2(n) &= \left\{ \frac{1}{2}, 0, \frac{3}{2}, -2, \frac{1}{2}, -6, -\frac{5}{2}, -2 \right\} \\ \text{correlation: } \gamma_1(n) &= \left\{ \frac{1}{2}, 0, \frac{3}{2}, -2, \frac{1}{2}, -6, -\frac{5}{2}, -2 \right\}\end{aligned}$$

Note that $y_2(n) = \gamma_2(n)$, because $h_2(-n) = h_2(n)$ (c)

$$\begin{aligned}\text{convolution: } y_3(n) &= \left\{ 4, 11, 20, 30, 20, 11, 4 \right\} \\ \text{correlation: } \gamma_1(n) &= \left\{ 1, 4, 10, 20, 25, 24, 16 \right\}\end{aligned}$$

(c)

$$\begin{aligned}\text{convolution: } y_4(n) &= \left\{ 1, 4, 10, 20, 25, 24, 16 \right\} \\ \text{correlation: } \gamma_4(n) &= \left\{ 4, 11, 20, 30, 20, 11, 4 \right\}\end{aligned}$$

$$\begin{aligned}\text{Note that } h_3(-n) &= h_4(n+3), \\ \text{hence, } \gamma_3(n) &= y_4(n+3) \\ \text{and } h_4(-n) &= h_3(n+3), \\ \Rightarrow \gamma_4(n) &= y_3(n+3)\end{aligned}$$

2.52

Obviously, the length of $h(n)$ is 2, i.e.

$$\begin{aligned}h(n) &= \{h_0, h_1\} \\ h_0 &= 1 \\ 3h_0 + h_1 &= 4 \\ \Rightarrow h_0 &= 1, h_1 = 1\end{aligned}$$

2.53

$$(2.5.6) \quad y(n) = -\sum_{k=1}^N a_k y(n-k) + \sum_{k=0}^M b_k x(n-k)$$

$$(2.5.9) \quad w(n) = -\sum_{k=1}^N a_k w(n-k) + x(n)$$

$$(2.5.10) \quad y(n) = \sum_{k=0}^M b_k w(n-k)$$

From (2.5.9) we obtain

$$x(n) = w(n) + \sum_{k=1}^N a_k w(n-k) \quad (\text{A})$$

By substituting (2.5.10) for $y(n)$ and (A) into (2.5.6), we obtain L.H.S = R.H.S.

2.54

$$y(n) - 4y(n-1) + 4y(n-2) = x(n) - x(n-1)$$

The characteristic equation is

$$\lambda^2 - 4\lambda + 4 = 0$$

$$\lambda = 2, 2. \text{ Hence,}$$

$$y_h(n) = c_1 2^n + c_2 n 2^n$$

The particular solution is

$$y_p(n) = k(-1)^n u(n).$$

Substituting this solution into the difference equation, we obtain

$$k(-1)^n u(n) - 4k(-1)^{n-1} u(n-1) + 4k(-1)^{n-2} u(n-2) = (-1)^n u(n) - (-1)^{n-1} u(n-1)$$

For $n = 2$, $k(1 + 4 + 4) = 2 \Rightarrow k = \frac{2}{9}$. The total solution is

$$y(n) = \left[c_1 2^n + c_2 n 2^n + \frac{2}{9} (-1)^n \right] u(n)$$

From the initial conditions, we obtain $y(0) = 1$, $y(1) = 2$. Then,

$$c_1 + \frac{2}{9} = 1$$

$$\Rightarrow c_1 = \frac{7}{9},$$

$$2c_1 + 2c_2 - \frac{2}{9} = 2$$

$$\Rightarrow c_2 = \frac{1}{3},$$

2.55

From problem 2.54,

$$h(n) = [c_1 2^n + c_2 n 2^n] u(n)$$

With $y(0) = 1$, $y(1) = 3$, we have

$$c_1 = 1$$

$$2c_1 + 2c_2 = 3$$

$$\Rightarrow c_2 = \frac{1}{2}$$

$$\text{Thus } h(n) = \left[2^n + \frac{1}{2} n 2^n \right] u(n)$$

2.56

$$\begin{aligned} x(n) &= x(n) * \delta(n) \\ &= x(n) * [u(n) - u(n-1)] \\ &= [x(n) - x(n-1)] * u(n) \\ &= \sum_{k=-\infty}^{\infty} [x(k) - x(k-1)] u(n-k) \end{aligned}$$

2.57

Let $h(n)$ be the impulse response of the system

$$\begin{aligned} s(k) &= \sum_{m=-\infty}^k h(m) \\ \Rightarrow h(k) &= s(k) - s(k-1) \\ y(n) &= \sum_{k=-\infty}^{\infty} h(k)x(n-k) \\ &= \sum_{k=-\infty}^{\infty} [s(k) - s(k-1)]x(n-k) \end{aligned}$$

2.58

$$\begin{aligned} x(n) &= \begin{cases} 1, & n_0 - N \leq n \leq n_0 + N \\ 0, & \text{otherwise} \end{cases} \\ y(n) &= \begin{cases} 1, & -N \leq n \leq N \\ 0, & \text{otherwise} \end{cases} \\ \gamma_{xx}(l) &= \sum_{n=-\infty}^{\infty} x(n)x(n-l) \end{aligned}$$

The range of non-zero values of $\gamma_{xx}(l)$ is determined by

$$\begin{aligned} n_0 - N &\leq n \leq n_0 + N \\ n_0 - N &\leq n - l \leq n_0 + N \end{aligned}$$

which implies

$$-2N \leq l \leq 2N$$

For a given shift l , the number of terms in the summation for which both $x(n)$ and $x(n-l)$ are non-zero is $2N + 1 - |l|$, and the value of each term is 1. Hence,

$$\gamma_{xx}(l) = \begin{cases} 2N + 1 - |l|, & -2N \leq l \leq 2N \\ 0, & \text{otherwise} \end{cases}$$

For $\gamma_{xy}(l)$ we have

$$\gamma_{xy}(l) = \begin{cases} 2N + 1 - |l - n_0|, & n_0 - 2N \leq l \leq n_0 + 2N \\ 0, & \text{otherwise} \end{cases}$$

2.59

(a)

$$\begin{aligned} \gamma_{xx}(l) &= \sum_{n=-\infty}^{\infty} x(n)x(n-l) \\ \gamma_{xx}(-3) &= x(0)x(3) = 1 \\ \gamma_{xx}(-2) &= x(0)x(2) + x(1)x(3) = 3 \end{aligned}$$

$$\gamma_{xx}(-1) = x(0)x(1) + x(1)x(2) + x(2)x(3) = 5$$

$$\gamma_{xx}(0) = \sum_{n=0}^3 x^2(n) = 7$$

$$\text{Also } \gamma_{xx}(-l) = \gamma_{xx}(l)$$

$$\text{Therefore } \gamma_{xx}(l) = \{1, 3, 5, 7, 5, 3, 1\}$$

(b)

$$\gamma_{yy}(l) = \sum_{n=-\infty}^{\infty} y(n)y(n-l)$$

We obtain

$$\gamma_{yy}(l) = \{1, 3, 5, 7, 5, 3, 1\}$$

we observe that $y(n) = x(-n + 3)$, which is equivalent to reversing the sequence $x(n)$. This has not changed the autocorrelation sequence.

2.60

$$\begin{aligned} \gamma_{xx}(l) &= \sum_{n=-\infty}^{\infty} x(n)x(n-l) \\ &= \begin{cases} 2N+1-|l|, & -2N \leq l \leq 2N \\ 0, & \text{otherwise} \end{cases} \\ \gamma_{xx}(0) &= 2N+1 \end{aligned}$$

Therefore, the normalized autocorrelation is

$$\begin{aligned} \rho_{xx}(l) &= \frac{1}{2N+1}(2N+1-|l|), -2N \leq l \leq 2N \\ &= 0, \text{ otherwise} \end{aligned}$$

2.61

(a)

$$\begin{aligned} \gamma_{xx}(l) &= \sum_{n=-\infty}^{\infty} x(n)x(n-l) \\ &= \sum_{n=-\infty}^{\infty} [s(n) + \gamma_1 s(n-k_1) + \gamma_2 s(n-k_2)] * \\ &\quad [s(n-l) + \gamma_1 s(n-l-k_1) + \gamma_2 s(n-l-k_2)] \\ &= (1 + \gamma_1^2 + \gamma_2^2)\gamma_{ss}(l) + \gamma_1 [\gamma_{ss}(l+k_1) + \gamma_{ss}(l-k_1)] \\ &\quad + \gamma_2 [\gamma_{ss}(l+k_2) + \gamma_{ss}(l-k_2)] \\ &\quad + \gamma_1 \gamma_2 [\gamma_{ss}(l+k_1-k_2) + \gamma_{ss}(l+k_2-k_1)] \end{aligned}$$

(b) $\gamma_{xx}(l)$ has peaks at $l = 0, \pm k_1, \pm k_2$ and $\pm(k_1 + k_2)$. Suppose that $k_1 < k_2$. Then, we can determine γ_1 and k_1 . The problem is to determine γ_2 and k_2 from the other peaks.

(c) If $\gamma_2 = 0$, the peaks occur at $l = 0$ and $l = \pm k_1$. Then, it is easy to obtain γ_1 and k_1 .

2.62

- (a)
 (b) variance = 0.01. Refer to fig 2.7.
 (b) Delay D = 20. Refer to fig 2.7.

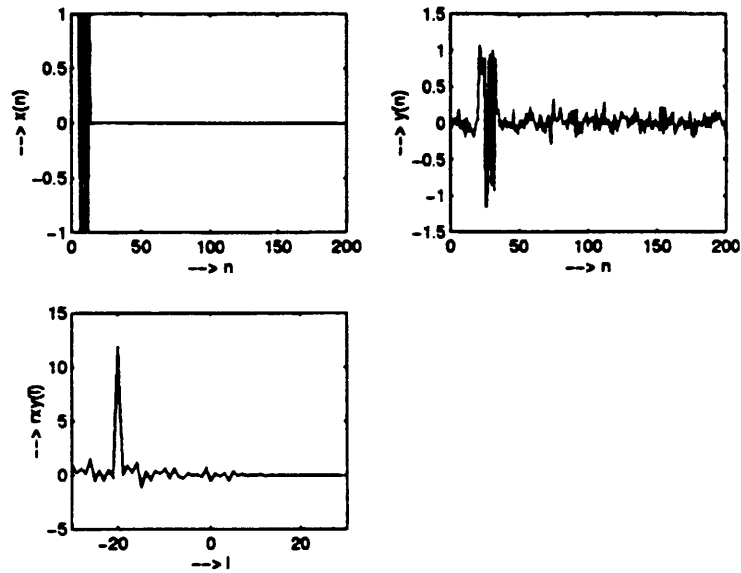

Figure 2.7: variance = 0.01

- (c) variance = 0.1. Delay D = 20. Refer to fig 2.8.
 (d) Variance = 1. delay D = 20. Refer to fig 2.9.

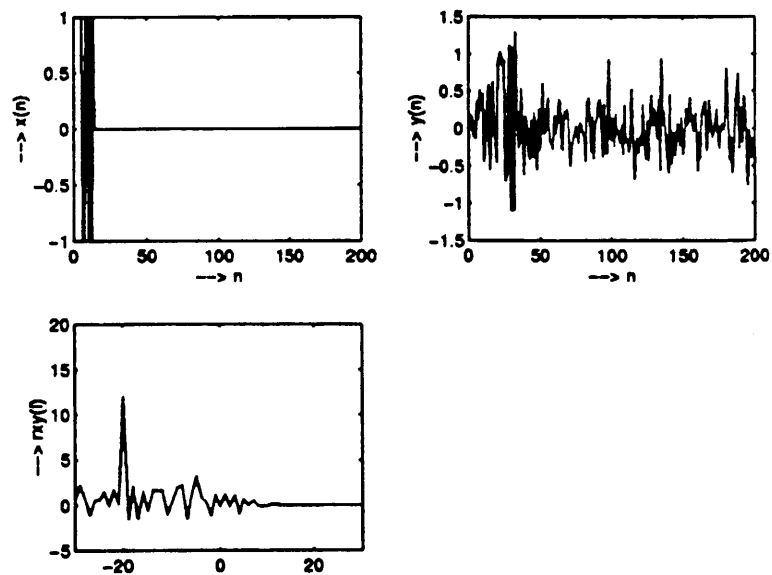

Figure 2.8: variance = 0.1

- (e) $x(n) = \{-1, -1, -1, +1, +1, +1, +1, -1, +1, -1, +1, +1, -1, -1, +1\}$. Refer to fig 2.10.
 (f) Refer to fig 2.11.

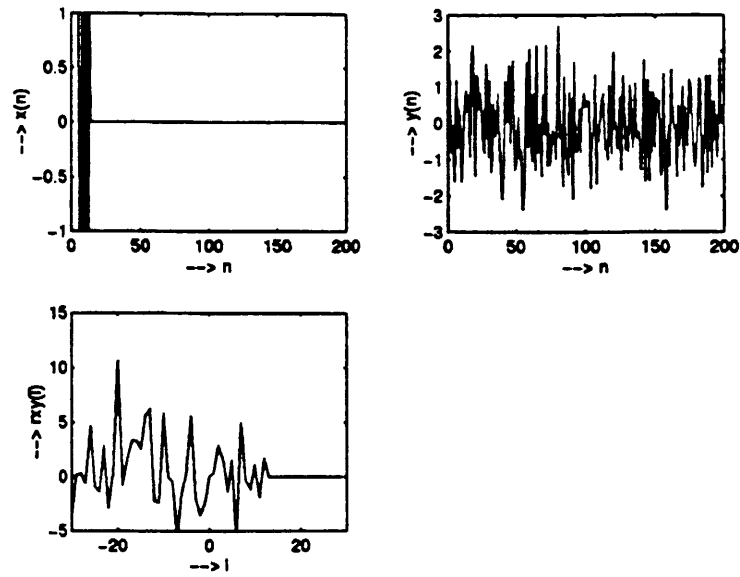

Figure 2.9: variance = 1

2.63

- (a) Refer to fig 2.12.
- (b) Refer to fig 2.13.
- (c) Refer to fig 2.14.
- (d) The step responses in fig 2.13 and fig 2.14 are similar except for the steady state value after $n=20$.

2.64

Refer to fig 2.15.

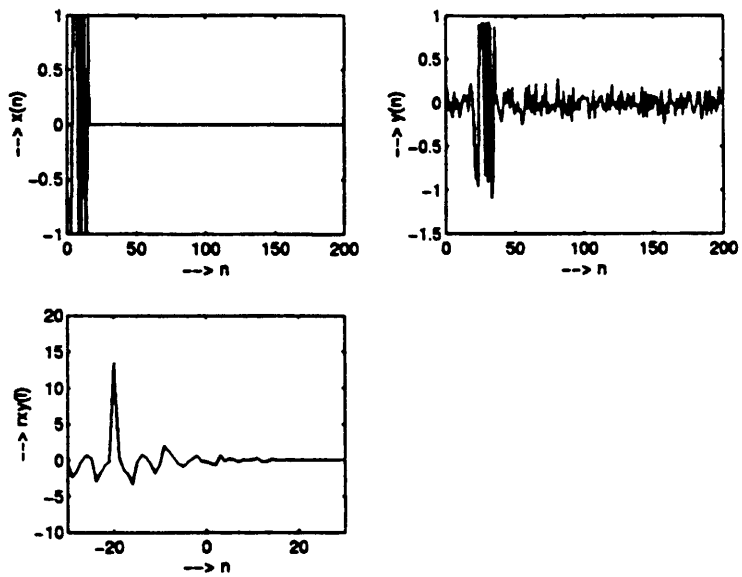

Figure 2.10:

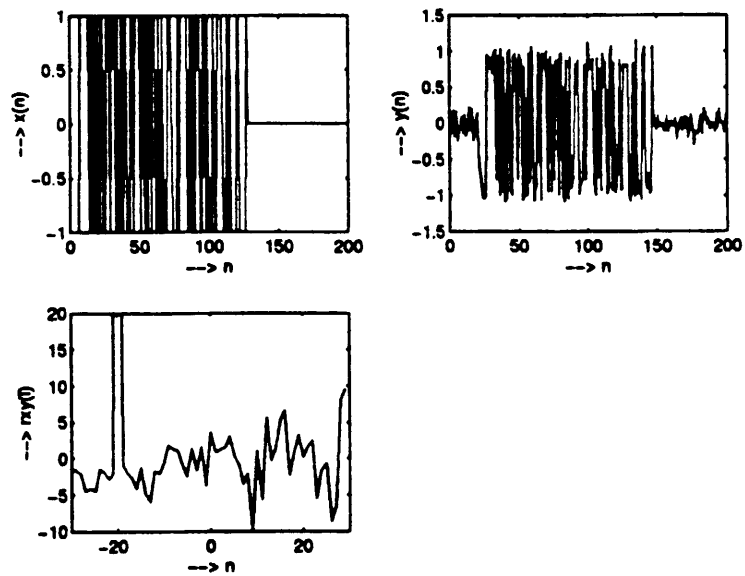

Figure 2.11:

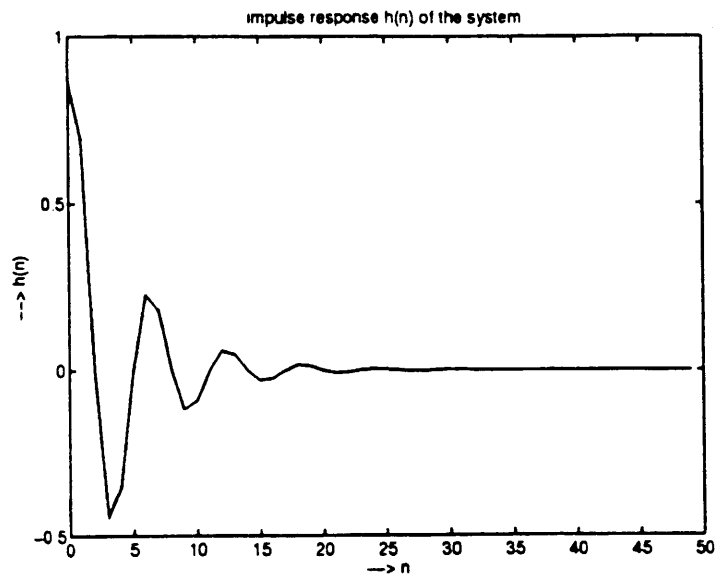

Figure 2.12:

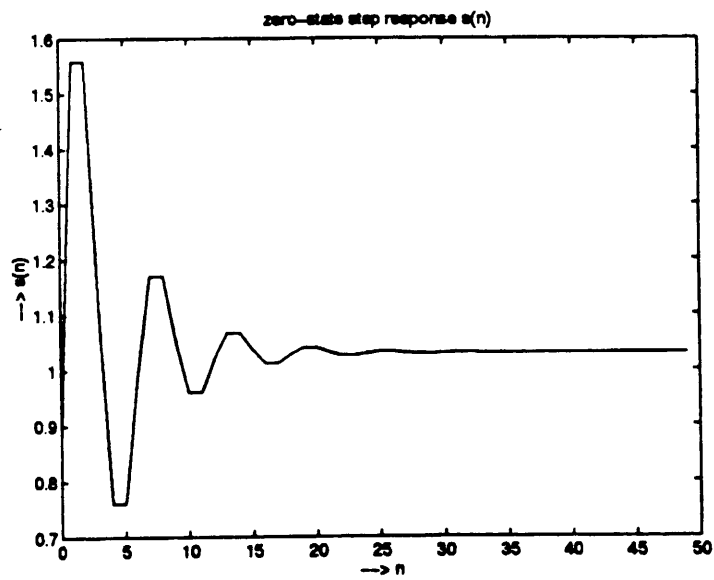

Figure 2.13:

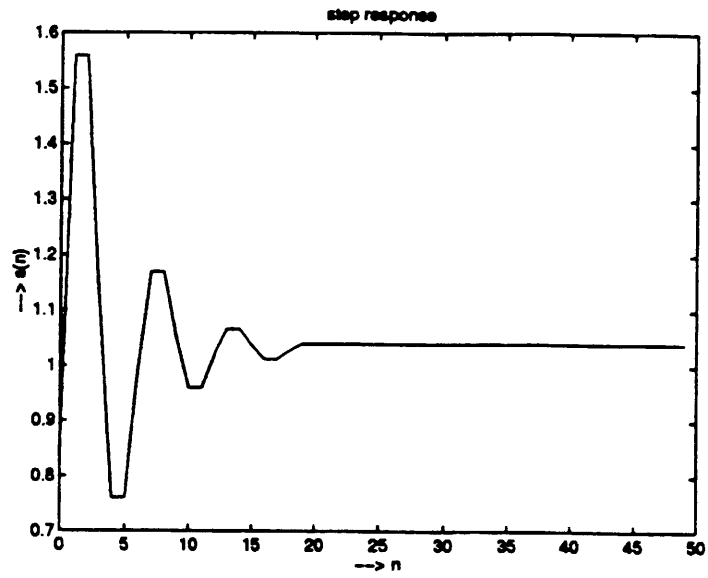

Figure 2.14:

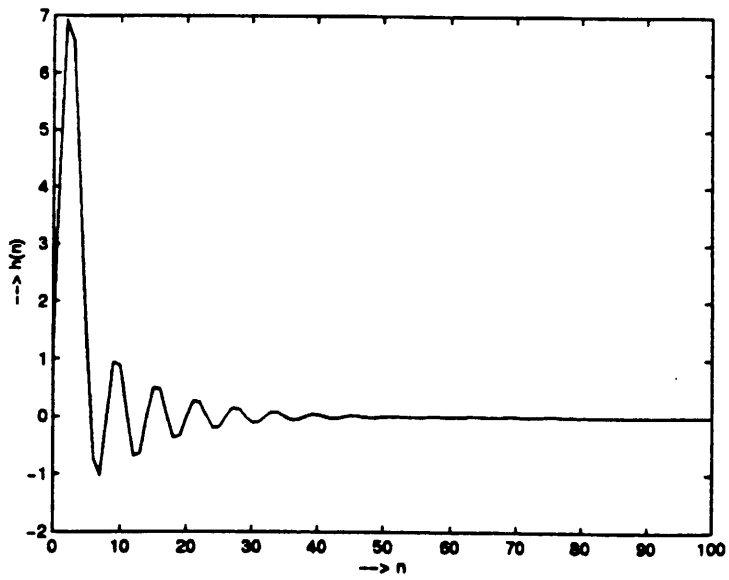

Figure 2.15:

Chapter 3

3.1

(a)

$$\begin{aligned} X(z) &= \sum_n x(n)z^{-n} \\ &= 3z^5 + 6 + z^{-1} - 4z^{-2} \text{ ROC: } 0 < |z| < \infty \end{aligned}$$

(b)

$$\begin{aligned} X(z) &= \sum_n x(n)z^{-n} \\ &= \sum_{n=5}^{\infty} \left(\frac{1}{2}\right)^n z^{-n} \\ &= \sum_{n=5}^{\infty} \left(\frac{1}{2z}\right)^n \\ &= \sum_{m=0}^{\infty} \left(\frac{1}{2}z^{-1}\right)^{m+5} \\ &= \left(\frac{z^{-1}}{2}\right)^5 \frac{1}{1 - \frac{1}{2}z^{-1}} \\ &= \left(\frac{1}{32}\right) \frac{z^{-5}}{1 - \frac{1}{2}z^{-1}} \text{ ROC: } |z| > \frac{1}{2} \end{aligned}$$

3.2

(a)

$$\begin{aligned} X(z) &= \sum_n x(n)z^{-n} \\ &= \sum_{n=0}^{\infty} (1+n)z^{-n} \\ &= \sum_{n=0}^{\infty} z^{-n} + \sum_{n=0}^{\infty} nz^{-n} \\ \text{But } \sum_{n=0}^{\infty} z^{-n} &= \frac{1}{1-z^{-1}} \text{ ROC: } |z| > 1 \end{aligned}$$

$$\text{and } \sum_{n=0}^{\infty} nz^{-n} = \frac{z^{-1}}{(1-z^{-1})^2} \text{ ROC: } |z| > 1$$

$$\begin{aligned} \text{Therefore, } X(z) &= \frac{1-z^{-1}}{(1-z^{-1})^2} + \frac{z^{-1}}{(1-z^{-1})^2} \\ &= \frac{1}{(1-z^{-1})^2} \end{aligned}$$

(b)

$$\begin{aligned} X(z) &= \sum_{n=0}^{\infty} (a^n + a^{-n})z^{-n} \\ &= \sum_{n=0}^{\infty} a^n z^{-n} + \sum_{n=0}^{\infty} a^{-n} z^{-n} \end{aligned}$$

$$\text{But } \sum_{n=0}^{\infty} a^n z^{-n} = \frac{1}{1-az^{-1}} \text{ ROC: } |z| > |a|$$

$$\text{and } \sum_{n=0}^{\infty} a^{-n} z^{-n} = \frac{1}{(1-\frac{1}{a}z^{-1})^2} \text{ ROC: } |z| > \frac{1}{|a|}$$

$$\begin{aligned} \text{Hence, } X(z) &= \frac{1}{1-az^{-1}} + \frac{1}{1-\frac{1}{a}z^{-1}} \\ &= \frac{2 - (a + \frac{1}{a})z^{-1}}{(1-az^{-1})(1-\frac{1}{a}z^{-1})} \text{ ROC: } |z| > \max(|a|, \frac{1}{|a|}) \end{aligned}$$

(c)

$$\begin{aligned} X(z) &= \sum_{n=0}^{\infty} (-\frac{1}{2})^n z^{-n} \\ &= \frac{1}{1 + \frac{1}{2}z^{-1}}, |z| > \frac{1}{2} \end{aligned}$$

(d)

$$\begin{aligned} X(z) &= \sum_{n=0}^{\infty} na^n \sin \omega_0 n z^{-n} \\ &= \sum_{n=0}^{\infty} na^n \left[\frac{e^{j\omega_0 n} - e^{-j\omega_0 n}}{2j} \right] z^{-n} \\ &= \frac{1}{2j} \left[\frac{ae^{j\omega_0} z^{-1}}{(1-ae^{j\omega_0} z^{-1})^2} - \frac{ae^{-j\omega_0} z^{-1}}{(1-ae^{-j\omega_0} z^{-1})^2} \right] \\ &= \frac{[az^{-1} - (az^{-1})^3] \sin \omega_0}{(1-2a \cos \omega_0 z^{-1} + a^2 z^{-2})^2}, |z| > a \end{aligned}$$

(e)

$$\begin{aligned} X(z) &= \sum_{n=0}^{\infty} na^n \cos \omega_0 n z^{-n} \\ &= \sum_{n=0}^{\infty} na^n \left[\frac{e^{j\omega_0 n} + e^{-j\omega_0 n}}{2} \right] z^{-n} \end{aligned}$$

$$\begin{aligned}
&= \frac{1}{2} \left[\frac{ae^{j\omega_0}z^{-1}}{(1 - ae^{j\omega_0}z^{-1})^2} + \frac{ae^{-j\omega_0}z^{-1}}{(1 - ae^{-j\omega_0}z^{-1})^2} \right] \\
&= \frac{[az^{-1} + (az^{-1})^3] \sin\omega_0 - 2a^2z^{-2}}{(1 - 2a\cos\omega_0z^{-1} + a^2z^{-2})^2}, \quad |z| > a
\end{aligned}$$

(f)

$$\begin{aligned}
X(z) &= A \sum_{n=0}^{\infty} r^n \cos(\omega_0 n + \phi) z^{-n} \\
&= A \sum_{n=0}^{\infty} r^n \left[\frac{e^{j\omega_0 n} e^{j\phi} + e^{-j\omega_0 n} e^{-j\phi}}{2} \right] z^{-n} \\
&= \frac{A}{2} \left[\frac{e^{j\phi}}{1 - re^{j\omega_0}z^{-1}} + \frac{e^{-j\phi}}{1 - re^{-j\omega_0}z^{-1}} \right] \\
&= A \left[\frac{\cos\phi - r\cos(\omega_0 - \phi)z^{-1}}{1 - 2r\cos\omega_0z^{-1} + r^2z^{-2}} \right], \quad |z| > r
\end{aligned}$$

(g)

$$\begin{aligned}
X(z) &= \sum_{n=1}^{\infty} \frac{1}{2} (n^2 + n) \left(\frac{1}{3}\right)^{n-1} z^{-n} \\
\text{But } \sum_{n=1}^{\infty} n \left(\frac{1}{3}\right)^{n-1} z^{-1} &= \frac{\left(\frac{1}{3}\right)3z^{-1}}{\left(1 - \frac{1}{3}z^{-1}\right)^2} = \frac{z^{-1}}{\left(1 - \frac{1}{3}z^{-1}\right)^2} \\
\sum_{n=1}^{\infty} n^2 \left(\frac{1}{3}\right)^{n-1} z^{-n} &= \frac{z^{-1} + \frac{1}{3}z^{-2}}{\left(1 - \frac{1}{3}z^{-1}\right)^3} \\
\text{Therefore, } X(z) &= \frac{1}{2} \left[\frac{z^{-1}}{\left(1 - \frac{1}{3}z^{-1}\right)^2} + \frac{z^{-1} + \frac{1}{3}z^{-2}}{\left(1 - \frac{1}{3}z^{-1}\right)^3} \right] \\
&= \frac{z^{-1}}{\left(1 - \frac{1}{3}z^{-1}\right)^3}, \quad |z| > \frac{1}{3}
\end{aligned}$$

(h)

$$\begin{aligned}
X(z) &= \sum_{n=0}^{\infty} \left(\frac{1}{2}\right)^n z^{-n} - \sum_{n=10}^{\infty} \left(\frac{1}{2}\right)^n z^{-n} \\
&= \frac{1}{1 - \frac{1}{2}z^{-1}} - \frac{\left(\frac{1}{2}\right)^{10} z^{-10}}{1 - \frac{1}{2}z^{-1}} \\
&= \frac{1 - \left(\frac{1}{2}z^{-1}\right)^{10}}{1 - \frac{1}{2}z^{-1}}, \quad |z| > \frac{1}{2}
\end{aligned}$$

The pole-zero patterns are as follows:

- (a) Double pole at $z = 1$ and a zero at $z = 0$.
- (b) Poles at $z = a$ and $z = \frac{1}{a}$. Zeros at $z = 0$ and $z = \frac{1}{2}(a + \frac{1}{a})$.
- (c) Pole at $z = -\frac{1}{2}$ and zero at $z = 0$.
- (d) Double poles at $z = ae^{j\omega_0}$ and $z = ae^{-j\omega_0}$ and zeros at $z = 0$, $z = \pm a$.
- (e) Double poles at $z = ae^{j\omega_0}$ and $z = ae^{-j\omega_0}$ and zeros are obtained by solving the quadratic

$$a\cos\omega_0 z^2 - 2a^2 z + a^3 \cos\omega_0 = 0.$$

- (f) Poles at $z = re^{j\omega_0}$ and $z = ae^{-j\omega_0}$ and zeros at $z = 0$, and $z = r\cos(\omega_0 - \phi)/\cos\phi$.
- (g) Triple pole at $z = \frac{1}{3}$ and zeros at $z = 0$ and $z = \frac{1}{3}$. Hence there is a pole-zero cancellation so

that in reality there is only a double pole at $z = \frac{1}{3}$ and a zero at $z = 0$.
 (h) $X(z)$ has a pole of order 9 at $z = 0$. For nine zeros which we find from the roots of

$$1 - \left(\frac{1}{2}z^{-1}\right)^{10} = 0$$

or, equivalently, $\left(\frac{1}{2}\right)^{10} - z^{10} = 0$

Hence, $z_n = \frac{1}{2}e^{\frac{j2\pi n}{10}}, n = 1, 2, \dots, k$.

Note the pole-zero cancellation at $z = \frac{1}{2}$.

3.3

(a)

$$\begin{aligned} X_1(z) &= \sum_{n=0}^{\infty} \left(\frac{1}{3}\right)^n z^{-n} + \sum_{n=-\infty}^0 \left(\frac{1}{2}\right)^n z^{-n} - 1 \\ &= \frac{1}{1 - \frac{1}{3}z^{-1}} + \sum_{n=0}^{\infty} \left(\frac{1}{2}\right)^n z^n - 1 \\ &= \frac{1}{1 - \frac{1}{3}z^{-1}} + \frac{1}{1 - \frac{1}{2}z} - 1, \\ &= \frac{\frac{5}{6}}{\left(1 - \frac{1}{3}z^{-1}\right)\left(1 - \frac{1}{2}z\right)} \end{aligned}$$

The ROC is $\frac{1}{3} < |z| < 2$.

(b)

$$\begin{aligned} X_2(z) &= \sum_{n=0}^{\infty} \left(\frac{1}{3}\right)^n z^{-n} - \sum_{n=0}^{\infty} 2^n z^{-n} \\ &= \frac{1}{1 - \frac{1}{3}z^{-1}} - \frac{1}{1 - 2z^{-1}}, \\ &= \frac{-\frac{5}{3}z^{-1}}{\left(1 - \frac{1}{3}z^{-1}\right)\left(1 - 2z^{-1}\right)} \end{aligned}$$

The ROC is $|z| > 2$.

(c)

$$\begin{aligned} X_3(z) &= \sum_{n=-\infty}^{\infty} x_1(n+4)z^{-n} \\ &= z^4 X_1(z) \\ &= \frac{\frac{5}{6}z^4}{\left(1 - \frac{1}{3}z^{-1}\right)\left(1 - \frac{1}{2}z\right)} \end{aligned}$$

The ROC is $\frac{1}{3} < |z| < 2$.

(d)

$$X_4(z) = \sum_{n=-\infty}^{\infty} x_1(-n)z^{-n}$$

$$\begin{aligned}
&= \sum_{m=-\infty}^{\infty} x_1(m)z^m \\
&= X_1(z^{-1}) \\
&= \frac{\frac{5}{6}}{(1 - \frac{1}{3}z)(1 - \frac{1}{2}z^{-1})}
\end{aligned}$$

The ROC is $\frac{1}{2} < |z| < 3$.

3.4

(a)

$$\begin{aligned}
X(z) &= \sum_{n=0}^{\infty} n(-1)^n z^{-n} \\
&= -z \frac{d}{dz} \sum_{n=0}^{\infty} (-1)^n z^{-n} \\
&= -z \frac{d}{dz} \left[\frac{1}{1+z^{-1}} \right] \\
&= -\frac{z^{-1}}{(1+z^{-1})^2}, |z| > 1
\end{aligned}$$

(b)

$$\begin{aligned}
X(z) &= \sum_{n=0}^{\infty} n^2 z^{-n} \\
&= z^2 \frac{d^2}{dz^2} \sum_{n=0}^{\infty} z^{-n} \\
&= z^2 \frac{d^2}{dz^2} \left[\frac{1}{1-z^{-1}} \right] \\
&= -\frac{z^{-1}}{(1-z^{-1})^2} + \frac{2z^{-1}}{(1-z^{-1})^3} \\
&= \frac{z^{-1}(1+z^{-1})}{(1-z^{-1})^3}, |z| > 1
\end{aligned}$$

(c)

$$\begin{aligned}
X(z) &= \sum_{n=-\infty}^{-1} -na^n z^{-n} \\
&= -z \frac{d}{dz} \sum_{n=-\infty}^{-1} a^n z^{-n} \\
&= -z \frac{d}{dz} \left[\frac{1}{1-az^{-1}} \right] \\
&= \frac{az^{-1}}{(1-az^{-1})^2}, |z| < |a|
\end{aligned}$$

(d)

$$X(z) = \sum_{n=0}^{\infty} (-1)^n n \cos \frac{\pi}{3} n z^{-n}$$

From formula (9) in table 3.3 with $a = -1$,

$$\begin{aligned} X(z) &= \frac{1 + z^{-1} \cos \frac{\pi}{3}}{1 + 2z^{-1} \cos \frac{\pi}{3} + z^{-2}} \\ &= \frac{1 + \frac{1}{2}z^{-1}}{1 + z^{-1} + z^{-2}}, \quad \text{ROC: } |z| > 1 \end{aligned}$$

(e)

$$\begin{aligned} X(z) &= \sum_{n=0}^{\infty} (-1)^n z^{-n} \\ &= \frac{1}{1 + z^{-1}}, \quad |z| > 1 \end{aligned}$$

(f)

$$\begin{aligned} x(n) &= \left\{ \underset{\uparrow}{1}, 0, -1, 0, 1, -1 \right\} \\ X(z) &= 1 - z^{-2} + z^{-4} - z^{-5}, \quad z \neq 0 \end{aligned}$$

3.5

Right-sided sequence : $x_r(n) = 0, n < n_0$

$$X_r(z) = \sum_{n=n_0}^{-1} x_r(n)z^{-n} + \sum_{n=0}^{\infty} x_r(n)z^{-n}$$

The term $\sum_{n=n_0}^{-1} x_r(n)z^{-n}$ converges for all z except $z = \infty$.

The term $\sum_{n=0}^{\infty} x_r(n)z^{-n}$ converges for all $|z| > r_0$ where some r_0 . Hence $X_r(z)$ converges for $r_0 < |z| < \infty$ when $n_0 < 0$ and $|z| > r_0$ for $n_0 > 0$

Left-sided sequence : $x_l(n) = 0, n > n_0$

$$X_l(z) = \sum_{n=-\infty}^0 x_l(n)z^{-n} + \sum_{n=1}^{n_0} x_l(n)z^{-n}$$

The first term converges for some $|z| < r_l$. The second term converges for all z , except $z = 0$. Hence, $X_l(z)$ converges for $0 < |z| < r_l$ when $n_0 > 0$, and for $|z| < r_l$ when $n_0 < 0$.

Finite-Duration Two-sided sequence : $x(n) = 0, n > n_0 \text{ and } n < n_1$, where $n_0 > n_1$

$$\begin{aligned} X(z) &= \sum_{n=n_1}^{n_0} x(n)z^{-n} \\ &= \sum_{n=n_1}^{-1} x(n)z^{-n} + \sum_{n=0}^{n_0} x(n)z^{-n} \end{aligned}$$

The first term converges everywhere except $z = \infty$.

The second term converges everywhere except $z = 0$. Therefore, $X(z)$ converges for $0 < |z| < \infty$.

3.6

$$y(n) = \sum_{k=-\infty}^n x(k)$$

$$\begin{aligned} \Rightarrow y(n) - y(n-1) &= x(n) \\ \text{Hence, } Y(z) - Y(z)z^{-1} &= X(z) \\ Y(z) &= \frac{X(z)}{1-z^{-1}} \end{aligned}$$

3.7

$$x_1(n) = \begin{cases} \left(\frac{1}{3}\right)^n, & n \geq 0 \\ \left(\frac{1}{2}\right)^{-n}, & n < 0 \end{cases}$$

$$\begin{aligned} X_1(z) &= \sum_{n=0}^{\infty} \left(\frac{1}{3}\right)^n z^{-n} + \sum_{n=-\infty}^{-1} \left(\frac{1}{2}\right)^{-n} z^{-n} \\ &= \frac{1}{1-\frac{1}{3}z^{-1}} + \frac{1}{1-\frac{1}{2}z} - 1 \\ &= \frac{\frac{5}{6}}{\left(1-\frac{1}{3}z^{-1}\right)\left(1-\frac{1}{2}z\right)} \end{aligned}$$

$$\begin{aligned} X_2(z) &= \sum_{n=0}^{\infty} \left(\frac{1}{2}\right)^n z^{-n} \\ &= \frac{1}{1-\frac{1}{2}z^{-1}}, \quad \frac{1}{2} < |z| < 2 \end{aligned}$$

$$\text{Then, } Y(z) = \frac{-2}{1-\frac{1}{3}z^{-1}} + \frac{\frac{10}{3}}{1-\frac{1}{2}z^{-1}} + \frac{\frac{-4}{3}}{1-2z^{-1}}$$

$$\text{Hence, } y(n) = \begin{cases} -2\left(\frac{1}{3}\right)^n + \frac{10}{3}\left(\frac{1}{2}\right)^n, & n \geq 0 \\ \frac{4}{3}(2)^n, & n < 0 \end{cases}$$

section
(a)

$$\begin{aligned} y(n) &= \sum_{k=-\infty}^n x(k) \\ &= \sum_{k=-\infty}^{\infty} x(k)u(n-k) \\ &= x(n) * u(n) \\ Y(z) &= X(z)U(z) \\ &= \frac{X(z)}{1-z^{-1}} \end{aligned}$$

(b)

$$\begin{aligned} u(n) * u(n) &= \sum_{k=-\infty}^{\infty} u(k)u(n-k) \\ &= \sum_{k=-\infty}^n u(k) = (n+1)u(n) \end{aligned}$$

$$\text{Hence, } x(n) = u(n) * u(n)$$

$$\text{and } X(z) = \frac{1}{(1-z^{-1})^2}, \quad |z| > 1$$

3.8

$y(n) = x(n)e^{j\omega_0 n}$. From the scaling theorem, we have $Y(z) = X(e^{-j\omega_0}z)$. Thus, the poles and zeros are phase rotated by an angle ω_0 .

3.9

$$\begin{aligned}x(n) &= \frac{1}{2} [u(n) + (-1)^n u(n)] \\X^+(z) &= \frac{\left(\frac{1}{1-z^{-1}} + \frac{1}{1+z^{-1}}\right)}{2}\end{aligned}$$

From the final value theorem

$$\begin{aligned}x(\infty) &= \lim_{z \rightarrow 1} (z-1)X^+(z) \\&= \lim_{z \rightarrow 1} \left(z + \frac{z(z-1)}{z+1}\right) \\&= \frac{1}{2}\end{aligned}$$

3.10

(a)

$$\begin{aligned}X(z) &= \frac{1 + 2z^4}{1 - 2z^{-1} + z^{-2}} \\&= 1 + 4z^{-1} + 7z^{-2} + 10z^{-3} + \dots \\ \text{Therefore, } x(n) &= \left\{ \underset{\uparrow}{1}, 4, 7, 10, \dots, 3n+1, \dots \right\}\end{aligned}$$

(b)

$$\begin{aligned}X(z) &= 2z + 5z^2 + 8z^3 + \dots \\ \text{Therefore, } x(n) &= \left\{ \dots, -(3n+1), \dots, 11, 8, 5, 2, \underset{\uparrow}{0} \right\}\end{aligned}$$

3.11

$$\begin{aligned}X(z) &= \frac{1}{(1-2z^{-1})(1-z^{-1})^2} \\&= \frac{A}{(1-2z^{-1})} + \frac{B}{(1-z^{-1})} + \frac{Cz^{-1}}{(1-z^{-1})^2} \\ A &= 4, B = -3, C = -1 \\ \text{Hence, } x(n) &= [4(2)^n - 3 - n] u(n)\end{aligned}$$

3.12

(a)

$$x_1(n) = \begin{cases} x\left(\frac{n}{2}\right), & n \text{ even} \\ 0, & n \text{ odd} \end{cases}$$

$$\begin{aligned}
X_1(z) &= \sum_{n=-\infty}^{\infty} x_1(n)z^{-n} \\
&= \sum_{n=-\infty}^{\infty} x\left(\frac{n}{2}\right)z^{-n} \\
&= \sum_{k=-\infty}^{\infty} x(k)z^{-2k} \\
&= X(z^2)
\end{aligned}$$

(b)

$$\begin{aligned}
x_2(n) &= x(2n) \\
X_2(z) &= \sum_{n=-\infty}^{\infty} x_2(n)z^{-n} \\
&= \sum_{n=-\infty}^{\infty} x(2n)z^{-n} \\
&= \sum_{k=-\infty}^{\infty} x(k)z^{-\frac{k}{2}} \\
&= \sum_{k=-\infty}^{\infty} \left[\frac{x(k) + (-1)^k x(k)}{2} \right] z^{-\frac{k}{2}}, k \text{ even} \\
&= \frac{1}{2} \sum_{k=-\infty}^{\infty} x(k)z^{-\frac{k}{2}} + \frac{1}{2} \sum_{k=-\infty}^{\infty} x(k)(-z^{\frac{1}{2}})^{-k} \\
&= \frac{1}{2} [X(\sqrt{z}) + X(-\sqrt{z})]
\end{aligned}$$

3.13

(a)

$$\begin{aligned}
X(z) &= \frac{1 - 3z^{-1}}{1 + 3z^{-1} + 2z^{-2}} \\
&= \frac{A}{(1 + z^{-1})} + \frac{B}{(1 + 2z^{-1})} \\
A &= 2, B = -1 \\
\text{Hence, } x(n) &= [2(-1)^n - (-2)^n] u(n)
\end{aligned}$$

(b)

$$\begin{aligned}
X(z) &= \frac{1}{1 - z^{-1} + \frac{1}{2}z^{-2}} \\
&= \frac{A(1 - \frac{1}{2}z^{-1}) + B(\frac{1}{2}z^{-1})}{1 - z^{-1} + \frac{1}{2}z^{-2}} \\
A &= 1, B = 1 \\
\text{Hence, } X(z) &= \frac{1 - \frac{1}{\sqrt{2}}(\cos \frac{\pi}{4})z^{-1}}{1 - 2\frac{1}{\sqrt{2}}(\cos \frac{\pi}{4})z^{-1} + (\frac{1}{\sqrt{2}})^2 z^{-2}}
\end{aligned}$$

$$+ \frac{\frac{1}{\sqrt{2}}(\sin \frac{\pi}{4})z^{-1}}{1 - 2\frac{1}{\sqrt{2}}(\cos \frac{\pi}{4})z^{-1} + (\frac{1}{\sqrt{2}})^2 z^{-2}}$$

Hence, $x(n) = \left[\left(\frac{1}{\sqrt{2}}\right)^n \cos \frac{\pi}{4} n + \left(\frac{1}{\sqrt{2}}\right)^n \sin \frac{\pi}{4} n \right] u(n)$

(c)

$$X(z) = \frac{z^{-6}}{1-z^{-1}} + \frac{z^{-7}}{1-z^{-1}}$$

$$x(n) = u(n-6) + u(n-7)$$

(d)

$$X(z) = \frac{1}{1+z^{-2}} + 2\frac{z^{-2}}{1+z^{-2}}$$

$$X(z) = 2 - \frac{1}{1+z^{-2}}$$

$$x(n) = \cos \frac{\pi}{2} n u(n) + 2\cos \frac{\pi}{2} (n-2) u(n-2)$$

$$x(n) = 2\delta(n) - \cos \frac{\pi}{2} n u(n)$$

(e)

$$X(z) = \frac{1}{4} \frac{1+6z^{-1}+z^{-2}}{(1-2z^{-1}+2z^{-2})(1-\frac{1}{2}z^{-1})}$$

$$= \frac{A(1-z^{-1})}{1-2z^{-1}+2z^{-2}} + \frac{Bz^{-1}}{1-2z^{-1}+2z^{-2}} + \frac{C}{1-\frac{1}{2}z^{-1}}$$

$$A = -\frac{3}{5}, B = \frac{23}{10}, C = \frac{17}{20}$$

Hence, $x(n) = \left[-\frac{3}{5} \left(\frac{1}{\sqrt{2}}\right)^n \cos \frac{\pi}{4} n + \frac{23}{10} \left(\frac{1}{\sqrt{2}}\right)^n \sin \frac{\pi}{4} n + \frac{17}{20} \left(\frac{1}{2}\right)^n \right] u(n)$

(f)

$$X(z) = \frac{2-1.5z^{-1}}{1-1.5z^{-1}+0.5z^{-2}}$$

$$= \frac{1}{1-\frac{1}{2}z^{-1}} + \frac{1}{1-z^{-1}}$$

$$x(n) = \left[\left(\frac{1}{2}\right)^n + 1 \right] u(n)$$

(g)

$$X(z) = \frac{1+2z^{-1}+z^{-2}}{1+4z^{-1}+4z^{-2}}$$

$$= 1 - \left(\frac{2z^{-1}+3z^{-2}}{(1+2z^{-1})(1+2z^{-1})} \right)$$

$$= 1 - \frac{2z^{-1}}{1+2z^{-1}} + \frac{z^{-2}}{(1+2z^{-1})^2}$$

$$x(n) = \delta(n) - 2(-2)^{n-1} u(n-1) + (n-1)(-2)^{n-1} u(n-1)$$

$$= \delta(n) + (n-3)(-2)^{n-1} u(n-1)$$

(h)

$$\begin{aligned}
X(z) &= \frac{1}{4} \frac{(z + \frac{1}{2})(z + \frac{1}{4})}{(z - \frac{1}{2})(z - \frac{1}{\sqrt{2}e^{j\frac{\pi}{4}}})(z - \frac{1}{\sqrt{2}e^{-j\frac{\pi}{4}}})} \\
&= \frac{1}{4} \frac{(1 + \frac{3}{4}z^{-1} + \frac{1}{8}z^{-2})z^{-1}}{(1 - \frac{1}{2}z^{-1})(1 - z^{-1} + \frac{1}{2}z^{-2})} \\
&= \frac{A(1 - \frac{1}{2}z^{-1})z^{-1}}{1 - z^{-1} + \frac{1}{2}z^{-2}} + \frac{A(\frac{1}{2}z^{-1})z^{-1}}{1 - z^{-1} + \frac{1}{2}z^{-2}} + \frac{Cz^{-1}}{1 - \frac{1}{2}z^{-1}} \\
A &= -\frac{1}{2}, B = \frac{7}{8}, C = \frac{3}{4} \\
\text{Hence, } x(n) &= \left[-\frac{1}{2} \left(\frac{1}{2}\right)^{\frac{n-1}{2}} \cos \frac{\pi}{4}(n-1) + \frac{7}{8} \left(\frac{1}{2}\right)^{\frac{n-1}{2}} \sin \frac{\pi}{4}(n-1) + \frac{3}{4} \left(\frac{1}{2}\right)^{n-1} \right] u(n-1)
\end{aligned}$$

(i)

$$\begin{aligned}
X(z) &= \frac{1 - \frac{1}{4}z^{-1}}{1 + \frac{1}{2}z^{-1}} \\
&= \frac{1}{1 + \frac{1}{2}z^{-1}} - \frac{1}{4} \frac{z^{-1}}{1 + \frac{1}{2}z^{-1}} \\
x(n) &= \left(-\frac{1}{2}\right)^n u(n) + \frac{1}{4} \left(-\frac{1}{2}\right)^{n-1} u(n-1)
\end{aligned}$$

(j)

$$\begin{aligned}
X(z) &= \frac{1 - az^{-1}}{z^{-1} - a} \\
&= -\frac{1}{a} \left(\frac{1 - az^{-1}}{1 - \frac{1}{a}z^{-1}} \right) \\
&= -\frac{1}{a} \left[\frac{1}{1 - \frac{1}{a}z^{-1}} - \frac{az^{-1}}{1 - \frac{1}{a}z^{-1}} \right] \\
x(n) &= -\frac{1}{a} \left(\frac{1}{a}\right)^n u(n) + \left(\frac{1}{a}\right)^{n-1} u(n-1) \\
&= \left(-\frac{1}{a}\right)^{n+1} u(n) + \left(\frac{1}{a}\right)^{n-1} u(n-1)
\end{aligned}$$

3.14

$$\begin{aligned}
X(z) &= \frac{5z^{-1}}{(1 - 2z^{-1})(3 - z^{-1})} \\
&= \frac{1}{1 - 2z^{-1}} + \frac{1}{1 - \frac{1}{3}z^{-1}} \\
\text{If } |z| > 2, x(n) &= \left[2^n - \left(\frac{1}{3}\right)^n \right] u(n) \\
\text{If } \frac{1}{3} < |z| < 2, x(n) &= -\left(\frac{1}{3}\right)^n u(-n-1) - 2^n u(-n-1) \\
\text{If } |z| < \frac{1}{3}, x(n) &= \left(\frac{1}{3}\right)^n u(-n-1) - 2^n u(-n-1)
\end{aligned}$$

3.15

(a)

$$\begin{aligned}
 x_1(n) &= \frac{1}{4} \left(\frac{1}{4}\right)^{n-1} u(n-1) \\
 \Rightarrow X_1(z) &= \frac{\left(\frac{1}{4}\right)z^{-1}}{1 - \frac{1}{4}z^{-1}}, |z| > \frac{1}{4} \\
 x_2(n) &= \left[1 + \left(\frac{1}{2}\right)^n\right] u(n) \\
 \Rightarrow X_2(z) &= \frac{1}{1 - z^{-1}} + \frac{1}{1 - \frac{1}{2}z^{-1}}, |z| > 1 \\
 Y(z) &= X_1(z)X_2(z) \\
 &= \frac{-\frac{4}{3}}{1 - \frac{1}{4}z^{-1}} + \frac{\frac{1}{3}}{1 - z^{-1}} + \frac{1}{1 - \frac{1}{2}z^{-1}} \\
 y(n) &= \left[-\frac{4}{3}\left(\frac{1}{4}\right)^n + \frac{1}{3} + \left(\frac{1}{2}\right)^n\right] u(n)
 \end{aligned}$$

(b)

$$\begin{aligned}
 x_1(n) &= u(n) \\
 \Rightarrow X_1(z) &= \frac{1}{1 - z^{-1}}, \\
 x_2(n) &= \delta(n) + \left(\frac{1}{2}\right)^n u(n) \\
 \Rightarrow X_2(z) &= 1 + \frac{1}{1 - \frac{1}{2}z^{-1}} \\
 Y(z) &= X_1(z)X_2(z) \\
 &= \frac{3}{1 - z^{-1}} - \frac{1}{1 - \frac{1}{2}z^{-1}} \\
 y(n) &= \left[3 - \left(\frac{1}{2}\right)^n\right] u(n)
 \end{aligned}$$

(c)

$$\begin{aligned}
 x_1(n) &= \left(\frac{1}{2}\right)^n u(n) \\
 \Rightarrow X_1(z) &= \frac{1}{1 - \frac{1}{2}z^{-1}}, \\
 x_2(n) &= \cos \pi n u(n) \\
 \Rightarrow X_2(z) &= \frac{1 + z^{-1}}{1 + 2z^{-1} + z^{-2}} \\
 Y(z) &= X_1(z)X_2(z) \\
 &= \frac{1 + z^{-1}}{(1 - \frac{1}{2}z^{-1})(1 + 2z^{-1} + z^{-2})} \\
 &= \frac{A(1 + z^{-1})}{1 + 2z^{-1} + z^{-2}} + \frac{B}{1 - \frac{1}{2}z^{-1}} \\
 A &= \frac{2}{3}, B = \frac{1}{3} \\
 y(n) &= \left[\frac{2}{3}\cos \pi n + \frac{1}{3}\left(\frac{1}{2}\right)^n\right] u(n)
 \end{aligned}$$

(d)

$$\begin{aligned}x_1(n) &= nu(n) \\ \Rightarrow X_1(z) &= \frac{z^{-1}}{(1-z^{-1})^2}, \\ x_2(n) &= 2^n u(n-1) \\ \Rightarrow X_2(z) &= \frac{2z^{-1}}{1-2z^{-1}} \\ Y(z) &= X_1(z)X_2(z) \\ &= \frac{2z^{-2}}{(1-z^{-1})^2(1-2z^{-1})} \\ &= \frac{-2}{1-z^{-1}} - \frac{-2z^{-1}}{(1-z^{-1})^2} + \frac{2}{1-2z^{-1}} \\ y(n) &= [-2(n+1) + 2^{n+1}] u(n)\end{aligned}$$

3.16

$$\begin{aligned}z^+ [x(n+1)] &= z [X^+(z) - x(0)] \\ &= zX^+(z) - zx(0) \\ \text{Therefore, } zX^+(z) &= \sum_{n=0}^{\infty} x(n+1)z^{-n} + zx(0) \\ (z-1)X^+(z) &= -\sum_{n=0}^{\infty} x(n)z^{-n} + \sum_{n=0}^{\infty} x(n+1)z^{-n} + zx(0) \\ \lim_{z \rightarrow 1} X^+(z)(z-1) &= x(0) + \sum_{n=0}^{\infty} x(n+1) - \sum_{n=0}^{\infty} x(n) \\ &= \lim_{m \rightarrow \infty} [x(0) + x(1) + x(2) + \dots + x(m) \\ &\quad - x(0) - x(1) - x(2) - \dots - x(m)] \\ &= \lim_{m \rightarrow \infty} x(m+1) \\ &= x(\infty)\end{aligned}$$

3.17

(a)

$$\begin{aligned}\sum_{n=-\infty}^{\infty} x^*(n)z^{-n} &= \sum_{n=-\infty}^{\infty} [x(n)(z^*)^{-n}]^* \\ &= X^*(z^*)\end{aligned}$$

(b)

$$\begin{aligned}\frac{1}{2}[X(z) + X^*(z^*)] &= \frac{1}{2}[z\{x(n)\} + z\{x^*(n)\}] \\ &= z \left[\frac{x(n) + x^*(n)}{2} \right] \\ &= z[\operatorname{Re}\{x(n)\}]\end{aligned}$$

(c)

$$\begin{aligned}\frac{1}{2j} [X(z) - X^*(z^*)] &= z \left[\frac{x(n) - x^*(n)}{2j} \right] \\ &= z [\text{Im}\{x(n)\}]\end{aligned}$$

(d)

$$\begin{aligned}X_k(z) &= \sum_{n=-\infty, n/k \text{ integer}}^{\infty} x\left(\frac{n}{k}\right) z^{-n} \\ &= \sum_{m=-\infty}^{\infty} x(m) z^{-mk} \\ &= X(z^k)\end{aligned}$$

(e)

$$\begin{aligned}\sum_{n=-\infty}^{\infty} e^{j\omega_0 n} x(n) z^{-n} &= \sum_{n=-\infty}^{\infty} x(n) (e^{-j\omega_0} z)^{-n} \\ &= X(ze^{-j\omega_0})\end{aligned}$$

3.18

(a)

$$\begin{aligned}X(z) &= \log(1 - 2z), |z| < \frac{1}{2} \\ Y(z) &= -z \frac{dX(z)}{dz} \\ &= \frac{-1}{1 - \frac{1}{2}z^{-1}}, |z| < \frac{1}{2} \\ \Rightarrow y(n) &= \left(\frac{1}{2}\right)^n, n < 0 \\ \text{Then, } x(n) &= \frac{1}{n} y(n) \\ &= \frac{1}{n} \left(\frac{1}{2}\right)^n u(-n - 1)\end{aligned}$$

(b)

$$\begin{aligned}X(z) &= \log\left(1 - \frac{1}{2}z^{-1}\right), |z| > \frac{1}{2} \\ Y(z) &= -z \frac{dX(z)}{dz} \\ &= \frac{-\frac{1}{2}z^{-1}}{1 - \frac{1}{2}z^{-1}}, |z| > \frac{1}{2} \\ \text{Hence, } y(n) &= -\frac{1}{2} \left(\frac{1}{2}\right)^{n-1} u(n - 1) \\ x(n) &= \frac{1}{n} y(n) \\ &= -\frac{1}{n} \left(\frac{1}{2}\right)^n u(n - 1)\end{aligned}$$

3.19

(a)

$$x_1(n) = r^n \sin \omega_0 n u(n), \quad 0 < r < 1$$

$$X_1(z) = \frac{r \sin \omega_0 z^{-1}}{1 - 2r \cos \omega_0 z^{-1} + r^2 z^{-2}}$$

Zero at $z = 0$ and poles at $z = r e^{\pm j \omega_0} = r(\cos \omega_0 \pm j \sin \omega_0)$.

(b)

$$X_2(z) = \frac{z}{(1 - r e^{j \omega_0} z^{-1})(1 - r e^{-j \omega_0} z^{-1})}$$

$$= \frac{z}{1 - 2r \cos \omega_0 z^{-1} + r^2 z^{-2}}$$

(c) $X_1(z)$ and $X_2(z)$ differ by a constant, which can be determined by giving the value of $X_1(z)$ at $z = 1$.

3.20

Assume that the polynomial has real coefficients and a complex root and prove that the complex conjugate of the root will also be a root. Hence, let $p(z)$ be a polynomial and z_1 is a complex root. Then,

$$a_n z_1^n + a_{n-1} z_1^{n-1} + \dots + a_1 z_1 + a_0 = 0 \quad (1)$$

The complex conjugate of (1) is

$$a_n (z_1^*)^n + a_{n-1} (z_1^*)^{n-1} + \dots + a_1 (z_1^*) + a_0 = 0$$

Therefore, z_1^* is also a root.

3.21

Convolution property:

$$z \{x_1(n) * x_2(n)\} = \sum_{n=-\infty}^{\infty} \left[\sum_{k=-\infty}^{\infty} x_1(k) x_2(n-k) \right] z^{-n}$$

$$= \sum_{k=-\infty}^{\infty} x_1(k) \sum_{n=-\infty}^{\infty} x_2(n-k) z^{-n}$$

$$= \sum_{k=-\infty}^{\infty} x_1(k) z^{-k} X_2(z)$$

$$= X_1(z) X_2(z)$$

Correlation property:

$$r_{12}(l) = x_1(n) * x_2(-n)$$

$$R_{12}(z) = z \{x_1(n) * x_2(-n)\}$$

$$= X_1(z) z \{x_2(-n)\}$$

$$= X_1(z) X_2(z^{-1})$$

3.22

$$\begin{aligned}
 X(z) &= 1 + z + \frac{z^2}{2!} + \frac{z^3}{3!} + \dots \\
 &\quad + 1 + z^{-1} + \frac{z^{-2}}{2!} + \frac{z^{-3}}{3!} + \dots \\
 x(n) &= \delta(n) + \frac{1}{n!}
 \end{aligned}$$

3.23

(a)

$$\begin{aligned}
 X(z) &= \frac{1}{1 + 1.5z^{-1} - 0.5z^{-2}} \\
 &= \frac{0.136}{1 - 0.28z^{-1}} + \frac{0.864}{1 + 1.78z^{-1}} \\
 \text{Hence, } x(n) &= [0.136(0.28)^n + 0.864(-1.78)^n] u(n)
 \end{aligned}$$

(b)

$$\begin{aligned}
 X(z) &= \frac{1}{1 - 0.5z^{-1} + 0.6z^{-2}} \\
 &= \frac{1 - 0.25z^{-1}}{1 - 0.5z^{-1} + 0.6z^{-2}} + 0.3412 \frac{0.7326z^{-1}}{1 - 0.5z^{-1} + 0.6z^{-2}} \\
 \text{Then, } x(n) &= (0.7746)^n [\cos 1.24n + 0.3412 \sin 1.24n] u(n)
 \end{aligned}$$

partial check: $x(0) = 1, x(1) = 0.5016, x(2) = -0.3476, x(\infty) = 0$. From difference equation, $x(n) - 0.5x(n-1) + 0.6x(n-2) = \delta(n)$ we obtain, $x(0) = 1, x(1) = 0.5, x(2) = -0.35, x(\infty) = 0$.

3.24

(a)

$$\begin{aligned}
 X(z) &= \frac{1}{1 - 1.5z^{-1} + 0.5z^{-2}} \\
 &= \frac{2}{1 - z^{-1}} - \frac{1}{1 - 0.5z^{-1}} \\
 \text{For } |z| < 0.5, x(n) &= [(0.5)^n - 2] u(-n-1) \\
 \text{For } |z| > 1, x(n) &= [2 - (0.5)^n] u(n) \\
 \text{For } 0.5 < |z| < 1, x(n) &= -(0.5)^n u(n) - 2u(-n-1)
 \end{aligned}$$

(b)

$$\begin{aligned}
 X(z) &= \frac{1}{(1 - 0.5z^{-1})^2} \\
 &= \left[\frac{0.5z^{-1}}{(1 - 0.5z^{-1})^2} \right] 2z \\
 \text{For } |z| > 0.5, x(n) &= 2(n+1)(0.5)^{n+1} u(n+1)
 \end{aligned}$$

$$\begin{aligned}
&= (n+1)(0.5)^n u(n) \\
\text{For } |z| < 0.5, x(n) &= -2(n+1)(0.5)^{n+1} u(-n-2) \\
&= -(n+1)(0.5)^n u(-n-1)
\end{aligned}$$

3.25

$$\begin{aligned}
X(z) &= \frac{3}{1 - \frac{10}{3}z^{-1} + z^{-2}} \\
&= \frac{-\frac{3}{8}}{1 - \frac{1}{3}z^{-1}} + \frac{\frac{27}{8}}{1 - 3z^{-1}} \\
\text{ROC: } \frac{1}{3} < |z| < 3, x(n) &= \frac{3}{8}\left(\frac{1}{3}\right)^n u(n) - \frac{27}{8}3^n u(-n-1)
\end{aligned}$$

3.26

$$\begin{aligned}
X(z) &= \sum_{n=-\infty}^{\infty} x(n)z^{-n} \\
&= \sum_{n=-\infty}^{\infty} x_1(n)x_2^*(n)z^{-n} \\
&= \sum_{n=-\infty}^{\infty} \frac{1}{2\pi j} \oint_c X_1(v)v^{n-1} dv x_2^*(n)z^{-n} \\
&= \frac{1}{2\pi j} \oint_c X_1(v)dv \left[\sum_{n=-\infty}^{\infty} x_2^*(n)\left(\frac{z}{v}\right)^{-n} \right] v^{-1} \\
&= \frac{1}{2\pi j} \oint_c X_1(v) \left[\sum_{n=-\infty}^{\infty} x_2(n)\left(\frac{z^*}{v^*}\right)^{-n} \right]^* v^{-1} dv \\
&= \frac{1}{2\pi j} \oint_c X_1(v)X_2^*\left(\frac{z^*}{v^*}\right)v^{-1} dv
\end{aligned}$$

3.27

Conjugation property:

$$\begin{aligned}
\sum_{n=-\infty}^{\infty} x^*(n)z^{-n} &= \left[\sum_{n=-\infty}^{\infty} x(n)(z^*)^{-n} \right]^* \\
&= X^*(z^*)
\end{aligned}$$

Parseval's relation:

$$\begin{aligned}
\sum_{n=-\infty}^{\infty} x_1(n)x_2^*(n) &= \sum_{n=-\infty}^{\infty} \frac{1}{2\pi j} \oint_c X_1(v)v^{n-1} dv x_2^*(n) \\
&= \frac{1}{2\pi j} \oint_c X_1(v) \left[\sum_{n=-\infty}^{\infty} x_2^*(n)\left(\frac{1}{v}\right)^{-n} \right] v^{-1} dv \\
&= \frac{1}{2\pi j} \oint_c X_1(v)X_2^*\left(\frac{1}{v^*}\right)dv
\end{aligned}$$

3.28

$$x(n) = \frac{1}{2\pi j} \oint_c \frac{z^n dz}{z-a},$$

where the radius of the contour c is $r_c > |a|$. For $n < 0$, let $w = \frac{1}{z}$. Then,

$$x(n) = \frac{1}{2\pi j} \oint_{c'} \frac{\frac{1}{a} w^{-n-1}}{w - \frac{1}{a}} dw,$$

where the radius of c' is $\frac{1}{r_c}$. Since $\frac{1}{r_c} < |a|$, there are no poles within c' and, hence $x(n) = 0$ for $n < 0$.

3.29

$x(n) = x(N-1-n)$, since $x(n)$ is even. Then

$$\begin{aligned} X(z) &= \sum_{n=0}^{N-1} x(n)z^{-n} \\ &= x(0) + x(1)z^{-1} + \dots + x(N-2)z^{-N+2} + x(N-1)z^{-N+1} \\ &= z^{-(N-1)/2} \sum_{n=0}^{N-1} x(n) \left[z^{(N-1-2n)/2} + z^{-(N-1-2n)/2} \right] \quad \text{N even} \end{aligned}$$

If we substitute z^{-1} for z and multiply both sides by $z^{-(N-1)}$ we obtain

$$z^{-(N-1)} X(z^{-1}) = X(z)$$

Hence, $X(z)$ and $X(z^{-1})$ have identical roots. This means that if z_1 is root (or a zero) of $X(z)$ then $\frac{1}{z_1}$ is also a root. Since $x(n)$ is real, then z_1^* must also be a root and so must $\frac{1}{z_1^*}$

section (a)

$$\begin{aligned} X_1(z) &= z^2 + z + 1 + z^{-1} + z^{-2} \\ X_2(z) &= 1 + z^{-1} + z^{-2} \\ Y(z) &= X_1(z)X_2(z) \\ &= z^2 + 2z + 3 + 3z^{-1} + 3z^{-2} + 2z^{-3} + z^{-4} \end{aligned}$$

$$\begin{aligned} \text{Hence, } x_1(n) * x_2(n) &= y(n) \\ &= \left\{ 1, 2, 3, 3, 3, 2, 1 \right\} \end{aligned}$$

By one-sided transform:

$$\begin{aligned} X_1^+(z) &= 1 + z^{-1} + z^{-2} \\ X_2^+(z) &= 1 + z^{-1} + z^{-2} \\ Y^+(z) &= 1 + 2z^{-1} + 3z^{-2} + 2z^{-3} + z^{-4} \\ \text{Hence, } y(n) &= \{1, 2, 3, 2, 1\} \end{aligned}$$

(b) Since both $x_1(n)$ and $x_2(n)$ are causal, the one-sided and two-sided transform yield identical results. Thus,

$$\begin{aligned} Y(z) &= X_1(z)X_2(z) \\ &= \frac{1}{(1 - \frac{1}{2}z^{-1})(1 - \frac{1}{3}z^{-1})} \end{aligned}$$

$$= \frac{3}{1 - \frac{1}{2}z^{-1}} - \frac{2}{1 - \frac{1}{3}z^{-1}}$$

$$\text{Therefore, } y(n) = \left[3\left(\frac{1}{2}\right)^n - 2\left(\frac{1}{3}\right)^n \right] u(n)$$

(c)

By convolution,

$$\begin{aligned} y(n) &= x_1(n) * x_2(n) \\ &= \left\{ 4, 11, 20, 30, 20, 11, 4 \right\} \end{aligned}$$

By one-sided z-transform,

$$\begin{aligned} X_1^+(z) &= 2 + 3z^{-1} + 4z^{-2} \\ X_2^+(z) &= 2 + z^{-1} \\ Y^+(z) &= X_1^+(z)X_2^+(z) \\ &= 4 + 8z^{-1} + 11z^{-2} + 4z^{-3} \end{aligned}$$

$$\text{Therefore, } y(n) = \left\{ 4, 8, 11, 4 \right\}$$

(d) Both $x_1(n)$ and $x_2(n)$ are causal. Hence, both types of transform yield the same result, i.e.,

$$X_1(z) = 1 + z^{-1} + z^{-2} + z^{-3} + z^{-4}$$

$$X_2(z) = 1 + z^{-1} + z^{-2}$$

$$\begin{aligned} \text{Then, } Y(z) &= X_1(z)X_2(z) \\ &= 1 + 2z^{-1} + 3z^{-2} + 3z^{-3} + 3z^{-4} + 2z^{-5} + z^{-6} \end{aligned}$$

$$\text{Therefore, } y(n) = \left\{ 1, 2, 3, 3, 3, 2, 1 \right\}$$

3.30

$$\begin{aligned} X^+(z) &= \sum_{n=0}^{\infty} x(n)z^{-n} \\ &= \sum_{n=0}^{\infty} z^{-n} \\ &= \frac{1}{1 - z^{-1}}, |z| > 1 \end{aligned}$$

3.31

From the definition of the Fibonacci sequence, $y(n) = y(n-1) + y(n-2)$, $y(0) = 1$. This is equivalent to a system described by the difference equation $y(n) = y(n-1) + y(n-2) + x(n)$, where $x(n) = \delta(n)$ and $y(n) = 0, n < 0$. The z-transform of this difference equation is $Y(z) = z^{-1}Y(z) + z^{-2}Y(z) + X(z)$. Hence, for $X(z) = 1$, we have

$$\begin{aligned} Y(z) &= \frac{1}{1 - z^{-1} - z^{-2}} \\ Y(z) &= \frac{A}{1 - \frac{\sqrt{5}+1}{2}z^{-1}} + \frac{B}{1 - \frac{1-\sqrt{5}}{2}z^{-1}} \end{aligned}$$

$$\begin{aligned} \text{where } A &= \frac{\sqrt{5}+1}{2\sqrt{5}}, B = \frac{\sqrt{5}-1}{2\sqrt{5}} = -\frac{1-\sqrt{5}}{2\sqrt{5}} \\ \text{Hence, } y(n) &= \frac{\sqrt{5}+1}{2\sqrt{5}} \left(\frac{\sqrt{5}+1}{2}\right)^n u(n) - \frac{1-\sqrt{5}}{2\sqrt{5}} \left(\frac{1-\sqrt{5}}{2}\right)^n u(n) \\ &= \frac{1}{\sqrt{5}} \left[\left(\frac{1+\sqrt{5}}{2}\right)^{n+1} - \left(\frac{1-\sqrt{5}}{2}\right)^{n+1} \right] u(n) \end{aligned}$$

3.32

(a)

$$Y^+(z) + \frac{1}{2} [z^{-1}Y^+(z) + y(-1)] - \frac{1}{4} [z^{-2}Y^+(z) + z^{-1}y(-1) + y(-2)] = 0$$

(a)

$$\begin{aligned} \text{Hence, } Y^+(z) &= \frac{\frac{1}{4}z^{-1} - \frac{1}{4}}{1 + \frac{1}{2}z^{-1} - \frac{1}{4}z^{-2}} \\ &= \frac{0.154}{1 - 0.31z^{-1}} - \frac{0.404}{1 + 0.81z^{-1}} \end{aligned}$$

$$\text{Therefore, } y(n) = [0.154(0.31)^n - 0.404(0.81)^n] u(n)$$

(b)

$$Y^+(z) - 1.5 [z^{-1}Y^+(z) + 1] + 0.5 [z^{-2}Y^+(z) + z^{-1} + 0] = 0$$

$$\begin{aligned} Y^+(z) &= \frac{1.5 - 0.5z^{-1}}{1 - 1.5z^{-1} + 0.5z^{-2}} \\ &= \frac{2}{1 - z^{-1}} - \frac{0.5}{1 - 0.5z^{-1}} \end{aligned}$$

$$\begin{aligned} \text{Therefore, } y(n) &= [2 - 0.5(0.5)^n] u(n) \\ &= [2 - (0.5)^{n+1}] u(n) \end{aligned}$$

(c)

$$\begin{aligned} Y^+(z) - 0.5 [z^{-1}Y^+(z) + 1] &= \frac{1}{1 - \frac{1}{3}z^{-1}} \\ Y^+(z) &= \frac{1.5 - \frac{1}{6}z^{-1}}{(1 - \frac{1}{3}z^{-1})(1 - 0.5z^{-1})} \\ &= \frac{\frac{7}{2}}{1 - 0.5z^{-1}} - \frac{2}{1 - \frac{1}{3}z^{-1}} \\ \text{Hence, } y(n) &= \left[\frac{7}{2}(0.5)^n - 2\left(\frac{1}{3}\right)^n \right] u(n) \end{aligned}$$

(d)

$$\begin{aligned} Y^+(z) - \frac{1}{4} [z^{-2}Y^+(z) + 1] &= \frac{1}{1 - z^{-1}} \\ Y^+(z) &= \frac{\frac{5}{4} - \frac{1}{4}z^{-1}}{(1 - z^{-1})(1 - \frac{1}{4}z^{-2})} \\ &= \frac{\frac{4}{3}}{1 - z^{-1}} + \frac{\frac{-3}{8}}{1 - \frac{1}{2}z^{-1}} + \frac{\frac{7}{24}}{1 + \frac{1}{2}z^{-1}} \\ \text{Hence, } y(n) &= \left[\frac{4}{3} - \frac{3}{8}\left(\frac{1}{2}\right)^n + \frac{7}{24}\left(-\frac{1}{2}\right)^n \right] u(n) \end{aligned}$$

3.33

(a)

$$\begin{aligned} Y(z)[1 - 0.2z^{-1}] &= X(z)[1 - 0.3z^{-1} - 0.02z^{-2}] \\ \frac{Y(z)}{X(z)} &= \frac{(1 - 0.1z^{-1})(1 - 0.2z^{-1})}{1 - 0.2z^{-1}} \\ &= 1 - 0.1z^{-1} \end{aligned}$$

(b)

$$\begin{aligned} Y(z) &= X(z)[1 - 0.1z^{-1}] \\ \frac{Y(z)}{X(z)} &= 1 - 0.1z^{-1} \end{aligned}$$

Therefore, (a) and (b) are equivalent systems.

3.34

$$\begin{aligned} X(z) &= \frac{1}{1 - az^{-1}} \\ \Rightarrow x_1(n) &= a^n u(n) \\ \text{or } x_2(n) &= -a^n u(-n - 1) \end{aligned}$$

Both $x_1(n)$ and $x_2(n)$ have the same autocorrelation sequence. Another sequence is obtained from $X(z^{-1}) = \frac{1}{1 - az}$

$$\begin{aligned} X(z^{-1}) &= \frac{1}{1 - az} \\ &= 1 - \frac{1}{1 - \frac{1}{a}z^{-1}} \end{aligned}$$

$$\text{Hence } x_3(n) = \delta(n) - \left(\frac{1}{a}\right)^n u(n)$$

We observe that $x_3(n)$ has the same autocorrelation as $x_1(n)$ and $x_2(n)$

3.35

$$\begin{aligned} H(z) &= \sum_{n=-1}^{-\infty} 3^n z^{-n} + \sum_{n=0}^{\infty} \left(\frac{2}{5}\right)^n z^{-n} \\ &= \frac{-1}{1 - 3z^{-1}} + \frac{1}{1 - \frac{2}{5}z^{-1}}, \text{ ROC: } \frac{2}{5} < |z| < 3 \\ X(z) &= \frac{1}{1 - z^{-1}} \\ Y(z) &= H(z)X(z) \\ &= \frac{-\frac{13}{5}z^{-1}}{(1 - z^{-1})(1 - 3z^{-1})(1 - \frac{2}{5}z^{-1})}, \text{ ROC: } 1 < |z| < 2 \\ &= \frac{\frac{13}{6}}{1 - z^{-1}} - \frac{\frac{3}{2}}{1 - 3z^{-1}} - \frac{\frac{2}{3}}{1 - \frac{2}{5}z^{-1}} \end{aligned}$$

Therefore,

$$y(n) = \frac{3}{2}3^n u(-n-1) + \left[\frac{13}{6} - \frac{2}{3} \left(\frac{2}{5} \right)^n \right] u(n)$$

3.36

(a)

$$\begin{aligned} h(n) &= \left(\frac{1}{3} \right)^n u(n) \\ H(z) &= \frac{1}{1 - \frac{1}{3}z^{-1}} \\ x(n) &= \left(\frac{1}{2} \right)^n \cos \frac{\pi n}{3} u(n) \\ X(z) &= \frac{1 - \frac{1}{4}z^{-1}}{1 - \frac{1}{2}z^{-1} + \frac{1}{4}z^{-2}} \\ Y(z) &= H(z)X(z) \\ &= \frac{1 - \frac{1}{4}z^{-1}}{(1 - \frac{1}{3}z^{-1})(1 - \frac{1}{2}z^{-1} + \frac{1}{4}z^{-2})} \\ &= \frac{\frac{1}{7}}{1 - \frac{1}{3}z^{-1}} + \frac{\frac{6}{7}(1 - \frac{1}{4}z^{-1})}{1 - \frac{1}{2}z^{-1} + \frac{1}{4}z^{-2}} + \frac{3\sqrt{3}}{7} \frac{\frac{\sqrt{3}}{4}z^{-1}}{1 - \frac{1}{2}z^{-1} + \frac{1}{4}z^{-2}} \end{aligned}$$

Therefore,

$$y(n) = \left[\frac{1}{7} \left(\frac{1}{3} \right)^n + \frac{6}{7} \left(\frac{1}{2} \right)^n \cos \frac{\pi n}{3} + \frac{3\sqrt{3}}{7} \left(\frac{1}{2} \right)^n \sin \frac{\pi n}{3} \right] u(n)$$

(b)

$$\begin{aligned} h(n) &= \left(\frac{1}{2} \right)^n u(n) \\ H(z) &= \frac{1}{1 - \frac{1}{2}z^{-1}} \\ x(n) &= \left(\frac{1}{3} \right)^n u(n) + \left(\frac{1}{2} \right)^{-n} u(-n-1) \\ X(z) &= \frac{1}{1 - \frac{1}{3}z^{-1}} - \frac{1}{1 - 2z^{-1}} \\ Y(z) &= H(z)X(z) \\ &= \frac{-\frac{5}{3}z^{-1}}{(1 - \frac{1}{2}z^{-1})(1 - \frac{1}{3}z^{-1})(1 - 2z^{-1})} \\ &= \frac{\frac{10}{3}}{1 - \frac{1}{2}z^{-1}} + \frac{-2}{1 - \frac{1}{3}z^{-1}} + \frac{-\frac{4}{3}}{1 - 2z^{-1}} \end{aligned}$$

Therefore,

$$y(n) = \left[\frac{10}{3} \left(\frac{1}{2} \right)^n - 2 \left(\frac{1}{3} \right)^n \right] u(n) + \frac{4}{3} 2^n u(-n-1)$$

(c)

$$\begin{aligned} y(n) &= -0.1y(n-1) + 0.2y(n-2) + x(n) + x(n-1) \\ H(z) &= \frac{1 + z^{-1}}{1 + 0.1z^{-1} - 0.2z^{-2}} \end{aligned}$$

$$\begin{aligned}
x(n) &= \left(\frac{1}{3}\right)^n u(n) \\
X(z) &= \frac{1}{1 - \frac{1}{3}z^{-1}} \\
Y(z) &= H(z)X(z) \\
&= \frac{1 + z^{-1}}{(1 - \frac{1}{3}z^{-1})(1 + 0.1z^{-1} - 0.2z^{-2})} \\
&= \frac{-8}{1 - \frac{1}{3}z^{-1}} + \frac{\frac{28}{3}}{1 - 0.4z^{-1}} + \frac{\frac{-1}{3}}{1 + 0.5z^{-1}}
\end{aligned}$$

Therefore,

$$y(n) = \left[-8\left(\frac{1}{3}\right)^n + \frac{28}{3}\left(\frac{2}{5}\right)^n - \frac{1}{3}\left(\frac{1}{2}\right)^n \right] u(n)$$

(d)

$$\begin{aligned}
y(n) &= \frac{1}{2}x(n) - \frac{1}{2}x(n-1) \\
\Rightarrow Y(z) &= \frac{1}{2}(1 - z^{-1})X(z) \\
X(z) &= \frac{10}{1 + z^{-2}} \\
\text{Hence, } Y(z) &= 10 \frac{(1 - z^{-1})/2}{1 + z^{-2}} \\
y(n) &= 5\cos\frac{\pi n}{2}u(n) - 5\cos\frac{\pi(n-1)}{2}u(n-1) \\
&= \left[5\cos\frac{\pi n}{2} - 5\sin\frac{\pi n}{2} \right] u(n-1) + 5\delta(n) \\
&= 5\delta(n) + \frac{10}{\sqrt{2}}\sin\left(\frac{\pi n}{2} + \frac{\pi}{4}\right)u(n-1) \\
&= \frac{10}{\sqrt{2}}\sin\left(\frac{\pi n}{2} + \frac{\pi}{4}\right)u(n)
\end{aligned}$$

(e)

$$\begin{aligned}
y(n) &= -y(n-2) + 10x(n) \\
Y(z) &= \frac{10}{1 + z^{-2}}X(z) \\
X(z) &= \frac{10}{1 + z^{-2}} \\
Y(z) &= \frac{100}{(1 + z^{-2})^2} \\
&= \frac{50}{1 + jz^{-1}} + \frac{50}{1 - jz^{-1}} + \frac{-25jz^{-1}}{(1 + jz^{-1})^2} + \frac{25jz^{-1}}{(1 - jz^{-1})^2}
\end{aligned}$$

Therefore,

$$\begin{aligned}
y(n) &= \{50[j^n + (-j)^n] - 25n[j^n + (-j)^n]\} u(n) \\
&= (50 - 25n)(j^n + (-j)^n)u(n) \\
&= (50 - 25n)2\cos\frac{\pi n}{2}u(n)
\end{aligned}$$

(f)

$$h(n) = \left(\frac{2}{3}\right)^n u(n)$$

$$\begin{aligned}
H(z) &= \frac{1}{1 - \frac{2}{5}z^{-1}} \\
x(n) &= u(n) - u(n-7) \\
X(z) &= \frac{1 - z^{-7}}{1 - z^{-1}} \\
Y(z) &= H(z)X(z) \\
&= \frac{1 - z^{-7}}{(1 - \frac{2}{5}z^{-1})(1 - z^{-1})} \\
&= \frac{\frac{5}{3}}{1 - z^{-1}} + \frac{\frac{-2}{3}}{1 - \frac{2}{5}z^{-1}} - \left[\frac{\frac{5}{3}}{1 - z^{-1}} + \frac{\frac{-2}{3}}{1 - \frac{2}{5}z^{-1}} \right] z^{-7}
\end{aligned}$$

Therefore,

$$y(n) = \frac{1}{3} \left[5 - 2\left(\frac{2}{5}\right)^n \right] u(n) - \frac{1}{3} \left[5 - 2\left(\frac{2}{5}\right)^{n-7} \right] u(n-7)$$

(g)

$$\begin{aligned}
h(n) &= \left(\frac{1}{2}\right)^n u(n) \\
H(z) &= \frac{1}{1 - \frac{1}{2}z^{-1}} \\
x(n) &= (-1)^n, \quad -\infty < n < \infty \\
&= \cos \pi n, \quad -\infty < n < \infty
\end{aligned}$$

$x(n)$ is periodic sequence and its z-transform does not exist.

$$\begin{aligned}
y(n) &= |H(w_0)| \cos[\pi n + \Theta(w_0)], \quad w_0 = \pi \\
H(z) &= \frac{1}{1 - \frac{1}{2}e^{-jw}} \\
H(\pi) &= \frac{1}{1 + \frac{1}{2}} \\
&= \frac{2}{3}, \quad \Theta = 0.
\end{aligned}$$

$$\text{Hence, } y(n) = \frac{2}{3} \cos \pi n, \quad -\infty < n < \infty$$

(h)

$$\begin{aligned}
h(n) &= \left(\frac{1}{2}\right)^n u(n) \\
H(z) &= \frac{1}{1 - \frac{1}{2}z^{-1}} \\
x(n) &= (n+1)\left(\frac{1}{4}\right)^n u(n) \\
X(z) &= \frac{1}{1 - \frac{1}{4}z^{-1}} + \frac{\frac{1}{4}z^{-1}}{(1 - \frac{1}{4}z^{-1})^2} \\
Y(z) &= H(z)X(z) \\
&= \frac{1}{(1 - \frac{1}{2}z^{-1})(1 - \frac{1}{4}z^{-1})^2} \\
&= \frac{4}{1 - \frac{1}{2}z^{-1}} + \frac{\frac{-1}{4}z^{-1}}{(1 - \frac{1}{4}z^{-1})^2} + \frac{-3}{1 - \frac{1}{4}z^{-1}}
\end{aligned}$$

Therefore,

$$y(n) = \left[4\left(\frac{1}{2}\right)^n - n\left(\frac{1}{4}\right)^n - 3\left(\frac{1}{4}\right)^n \right] u(n)$$

3.37

$$\begin{aligned} H(z) &= \frac{1 - 2z^{-1} + 2z^{-2} - z^{-3}}{(1 - z^{-1})(1 - \frac{1}{2}z^{-1})(1 - \frac{1}{5}z^{-1})}, \quad \frac{1}{2} < |z| < 1 \\ &= \frac{1 - z^{-1} + z^{-2}}{(1 - \frac{1}{2}z^{-1})(1 - \frac{1}{5}z^{-1})}, \quad \frac{1}{2} < |z| < 1 \end{aligned}$$

$$(a) Z_{1,2} = \frac{1 \pm j\sqrt{3}}{2}, p_1 = \frac{1}{2}, p_2 = \frac{1}{5}$$

$$(b) H(z) = 1 + \left[\frac{\frac{5}{2}}{1 - \frac{1}{2}z^{-1}} + \frac{-2.8}{1 - \frac{1}{5}z^{-1}} \right] z^{-1}$$

$$h(n) = \delta(n) + \left[5\left(\frac{1}{2}\right)^n - 14\left(\frac{1}{5}\right)^n \right] u(n)$$

3.38

$$y(n) = 0.7y(n-1) - 0.12y(n-2) + x(n-1) + x(n-2)$$

$$Y(z) = \frac{z^{-1} + z^{-2}}{1 - 0.7z^{-1} + 0.12z^{-2}} X(z)$$

$$x(n) = nu(n)$$

$$X(z) = \frac{z^{-1}}{(1 - z^{-1})^2}$$

$$Y(z) = \frac{z^{-2} + z^{-3}}{(1 - z^{-1})^2(1 - \frac{3}{10}z^{-1})(1 - \frac{2}{50}z^{-2})}$$

⇒ System is stable

$$Y(z) = \frac{4.76z^{-1}}{(1 - z^{-1})^2} + \frac{-12.36}{(1 - z^{-1})} + \frac{-26.5}{(1 - \frac{3}{10}z^{-1})} + \frac{38.9}{(1 - \frac{2}{5}z^{-1})}$$

$$y(n) = \left[4.76n - 12.36 - 26.5\left(\frac{3}{10}\right)^n + 38.9\left(\frac{2}{5}\right)^n \right] u(n)$$

3.39

(a)

$$y(n) = \frac{3}{4}y(n-1) - \frac{1}{8}y(n-2) + x(n)$$

$$Y(z) = \frac{1}{1 - \frac{3}{4}z^{-1} + \frac{1}{8}z^{-2}} X(z)$$

Impulse Response: $X(z) = 1$

$$Y(z) = \frac{2}{1 - \frac{1}{2}z^{-1}} - \frac{1}{1 - \frac{1}{4}z^{-1}}$$

$$\Rightarrow h(n) = \left[2\left(\frac{1}{2}\right)^n - \left(\frac{1}{4}\right)^n \right] u(n)$$

Since the poles of $H(z)$ are inside the unit circle, the system is stable (poles at $z = \frac{1}{2}, \frac{1}{4}$).

$$\begin{aligned}\text{Step Response: } X(z) &= \frac{1}{1-z^{-1}} \\ Y(z) &= \frac{\frac{8}{3}}{1-z^{-1}} - \frac{2}{1-\frac{1}{2}z^{-1}} + \frac{\frac{1}{3}}{1-\frac{1}{4}z^{-1}} \\ y(n) &= \left[\frac{8}{3} - 2\left(\frac{1}{2}\right)^n + \frac{1}{3}\left(\frac{1}{4}\right)^n \right] u(n)\end{aligned}$$

(b)

$$\begin{aligned}y(n) &= y(n-1) - \frac{1}{2}y(n-2) + x(n) + x(n-1) \\ Y(z) &= \frac{1+z^{-1}}{1-z^{-1} + \frac{1}{2}z^{-2}} X(z)\end{aligned}$$

$H(z)$ has zeros at $z = 0, 1$, and poles at $z = \frac{1 \pm j}{2}$. Hence, the system is stable.

$$\begin{aligned}\text{Impulse Response: } X(z) &= 1 \\ Y(z) &= \frac{1 - (\sqrt{2})^{-1} \cos \frac{\pi}{4} z^{-1}}{1 - 2(\sqrt{2})^{-1} \cos \frac{\pi}{4} z^{-1} + (\frac{1}{\sqrt{2}})^2 z^{-2}} + \frac{\frac{3}{2} z^{-1}}{1 - z^{-1} + \frac{1}{2} z^{-2}} \\ \Rightarrow y(n) = h(n) &= \left(\frac{1}{\sqrt{2}}\right)^n \left[\cos \frac{\pi}{4} n + \sin \frac{\pi}{4} n \right] u(n) \\ \text{Step Response: } X(z) &= \frac{1}{1-z^{-1}} \\ Y(z) &= \frac{1+z^{-1}}{(1-z^{-1})(1-z^{-1} + \frac{1}{2}z^{-2})} \\ &= \frac{-(1-\frac{1}{2}z^{-1})}{1-z^{-1} + \frac{1}{2}z^{-2}} + \frac{\frac{1}{2}z^{-1}}{1-z^{-1} + \frac{1}{2}z^{-2}} + \frac{2}{1-z^{-1}} \\ y(n) &= \left(\frac{1}{\sqrt{2}}\right)^n \left[\sin \frac{\pi}{4} n - \cos \frac{\pi}{4} n \right] u(n) + 2u(n)\end{aligned}$$

(c)

$$\begin{aligned}H(z) &= \frac{z^{-1}(1+z^{-1})}{(1-z^{-1})^3} \\ \Rightarrow h(n) &= n^2 u(n)\end{aligned}$$

Triple pole on the unit circle \Rightarrow the system is unstable.

$$\begin{aligned}\text{Step Response: } X(z) &= \frac{1}{1-z^{-1}} \\ Y(z) &= \frac{z^{-1}(1+z^{-1})}{(1-z^{-1})^4} \\ &= \frac{1}{3} \frac{z^{-1}(1+4z^{-1}+z^{-2})}{(1-z^{-1})^4} + \frac{1}{2} \frac{z^{-1}(1+z^{-1})}{(1-z^{-1})^3} + \frac{1}{6} \frac{z^{-1}}{(1-z^{-1})^2} \\ y(n) &= \left(\frac{1}{3}n^3 + \frac{1}{2}n^2 + \frac{1}{6}n\right)u(n) \\ &= \frac{1}{6}n(n+1)(2n+1)u(n)\end{aligned}$$

(d)

$$y(n) = 0.6y(n-1) - 0.08y(n-2) + x(n)$$

$$Y(z) = \frac{1}{1 - 0.6z^{-1} + 0.08z^{-2}} X(z)$$

$$\text{Impulse Response: } X(z) = 1$$

$$H(z) = \frac{1}{(1 - \frac{1}{5}z^{-1})(1 - \frac{2}{5}z^{-1})}$$

\Rightarrow zeros at $z = 0$, poles at $p_1 = \frac{1}{2}, p_2 = \frac{2}{5}$ system is stable.

$$H(z) = \frac{-1}{1 - \frac{1}{5}z^{-1}} + \frac{2}{1 - \frac{2}{5}z^{-1}}$$

$$\Rightarrow h(n) = \left[2\left(\frac{2}{5}\right)^n - \left(\frac{1}{5}\right)^n \right] u(n)$$

$$\text{Step Response: } X(z) = \frac{1}{1 - z^{-1}}$$

$$Y(z) = \frac{1}{(1 - \frac{1}{5}z^{-1})(1 - \frac{2}{5}z^{-1})(1 - z^{-1})}$$

$$Y(z) = \frac{\frac{25}{12}}{1 - z^{-1}} + \frac{\frac{1}{4}}{1 - \frac{1}{5}z^{-1}} + \frac{-\frac{4}{3}}{1 - \frac{2}{5}z^{-1}}$$

$$y(n) = \left[\frac{25}{12} + \frac{1}{4}\left(\frac{1}{5}\right)^n - \frac{4}{3}\left(\frac{2}{5}\right)^n \right] u(n)$$

(e)

$$y(n) = 0.7y(n-1) - 0.1y(n-2) + 2x(n) - x(n-2)$$

$$Y(z) = \frac{2 - z^{-2}}{1 - 0.7z^{-1} + 0.1z^{-2}} X(z)$$

$$= \frac{2 - z^{-2}}{(1 - \frac{1}{5}z^{-1})(1 - \frac{1}{2}z^{-1})} X(z)$$

zeros at $z = 0, 2$, and poles at $z = \frac{1}{2}, \frac{1}{5}$. Hence, the system is stable.

$$\text{Impulse Response: } X(z) = 1$$

$$H(z) = 2 + \left(\frac{-\frac{5}{3}}{1 - \frac{1}{2}z^{-1}} + \frac{\frac{46}{15}}{1 - \frac{1}{5}z^{-1}} \right) z^{-1}$$

$$\Rightarrow h(n) = 2\delta(n) - \frac{5}{3}\left(\frac{1}{2}\right)^{n-1}u(n-1) + \frac{46}{15}\left(\frac{1}{5}\right)^{n-1}u(n-1)$$

$$\text{Step Response: } X(z) = \frac{1}{1 - z^{-1}}$$

$$Y(z) = \frac{2 - z^{-2}}{(1 - z^{-1})(1 - \frac{1}{2}z^{-1})(1 - \frac{1}{5}z^{-1})}$$

$$= \frac{\frac{5}{2}}{1 - z^{-1}} + \frac{\frac{10}{3}}{1 - \frac{1}{2}z^{-1}} + \frac{-\frac{23}{6}}{1 - \frac{1}{5}z^{-1}}$$

$$y(n) = \left[\frac{5}{2} + \frac{10}{3}\left(\frac{1}{2}\right)^n - \frac{23}{6}\left(\frac{1}{5}\right)^n \right] u(n)$$

3.40

$$X(z) = \frac{(1 + z^{-1})}{(1 - \frac{1}{2}z^{-1})(1 - pz^{-1})(1 - p^*z^{-1})}, \quad p = -\frac{1}{2} + \frac{j}{2}$$

(a)

$$\begin{aligned}x_1(n) &= x(-n+2) \\X_1(z) &= z^{-2}X(z^{-1}) \\&= \frac{z^{-2}(1+z)}{(1-\frac{1}{2}z)(1-pz)(1-p^*z)}, \quad \text{ROC: } |z| < 2\end{aligned}$$

Zero at $z = -1$, Poles at $z = 2, \frac{1}{p}, \frac{1}{p^*}$ and $z = 0$.

(b)

$$\begin{aligned}x_2(n) &= e^{\frac{j\pi n}{3}}x(n) \\X_2(z) &= X(e^{-\frac{j\pi}{3}}z) \\&= \frac{1 + e^{\frac{j\pi}{3}}z^{-1}}{(1 - \frac{1}{2}e^{\frac{j\pi}{3}}z^{-1})(1 - pe^{\frac{j\pi}{3}}z^{-1})(1 - p^*e^{\frac{j\pi}{3}}z^{-1})}\end{aligned}$$

All poles and zeros are rotated by $\frac{\pi}{3}$ in a counterclockwise direction. The ROC for $X_2(z)$ is the same as the ROC of $X(z)$.

3.41

$$\begin{aligned}x(n) &= \left(\frac{1}{2}\right)^n u(n) - \frac{1}{4}\left(\frac{1}{2}\right)^{n-1} u(n-1) \\X(z) &= \frac{1}{1 - \frac{1}{2}z^{-1}} - \frac{1}{4} \frac{z^{-1}}{1 - \frac{1}{2}z^{-1}} \\&= \frac{1 - \frac{1}{4}z^{-1}}{1 - \frac{1}{2}z^{-1}} \\y(n) &= \left(\frac{1}{3}\right)^n u(n) \\Y(z) &= \frac{1}{1 - \frac{1}{3}z^{-1}}\end{aligned}$$

(a)

$$\begin{aligned}H(z) &= Y(z)X(z) \\&= \frac{1 - \frac{1}{2}z^{-1}}{(1 - \frac{1}{4}z^{-1})(1 - \frac{1}{3}z^{-1})} \\&= \frac{3}{1 - \frac{1}{4}z^{-1}} - \frac{2}{1 - \frac{1}{3}z^{-1}} \\h(n) &= \left[3\left(\frac{1}{4}\right)^n - 2\left(\frac{1}{3}\right)^n\right] u(n)\end{aligned}$$

(b)

$$\begin{aligned}H(z) &= \frac{1 - \frac{1}{2}z^{-1}}{1 - \frac{7}{12}z^{-1} + \frac{1}{12}z^{-2}} \\y(n) &= \frac{7}{12}y(n-1) - \frac{1}{12}y(n-2) + x(n) - \frac{1}{2}x(n-1)\end{aligned}$$

(c) Refer to fig 3.1.

(d) The poles of the system are inside the unit circle. Hence, the system is stable.

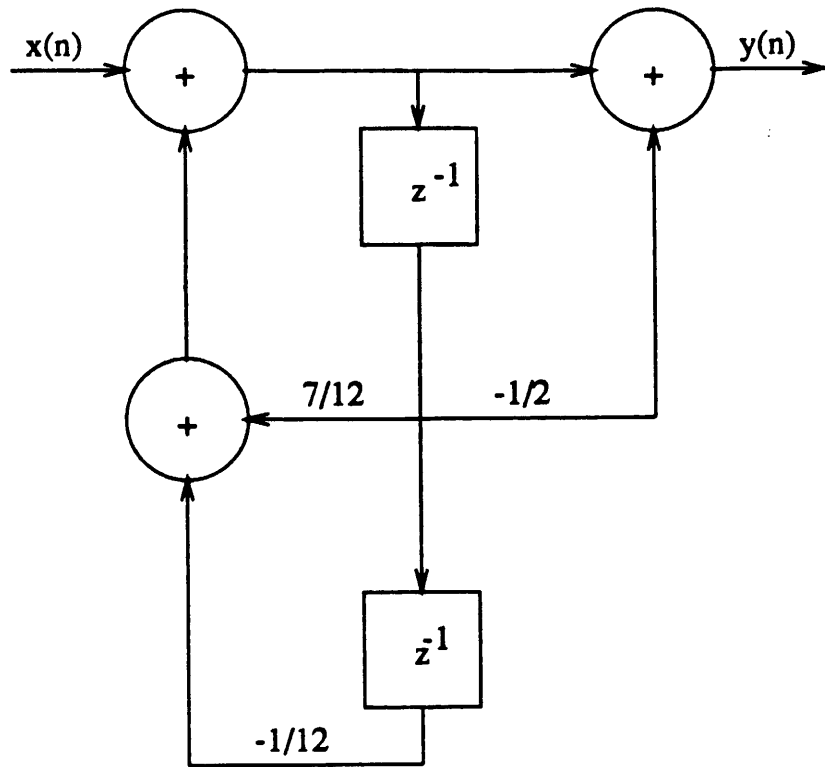

Figure 3.1:

3.42

$$H(z) = \frac{1}{1 + a_1 z^{-1} + a_2 z^{-2}}$$

If $a_1^2 - 4a_2 < 0$, there are two complex poles

$$p_{1,2} = \frac{-a_1 \pm j\sqrt{4a_2 - a_1^2}}{2}$$

$$|p_{1,2}|^2 = \left(\frac{a_1}{2}\right)^2 + \left(\frac{\sqrt{4a_2 - a_1^2}}{2}\right)^2 < 1$$

$$\Rightarrow a_2 < 1$$

If $a_1^2 - 4a_2 \geq 0$, there are two real poles

$$p_{1,2} = \frac{-a_1 \pm \sqrt{a_1^2 - 4a_2}}{2}$$

$$\frac{-a_1 + \sqrt{a_1^2 - 4a_2}}{2} < 1 \text{ and}$$

$$\frac{-a_1 - \sqrt{a_1^2 - 4a_2}}{2} > -1$$

$$\Rightarrow a_1 - a_2 < 1 \text{ and}$$

$$a_1 + a_2 > 1$$

Refer to fig 3.2.

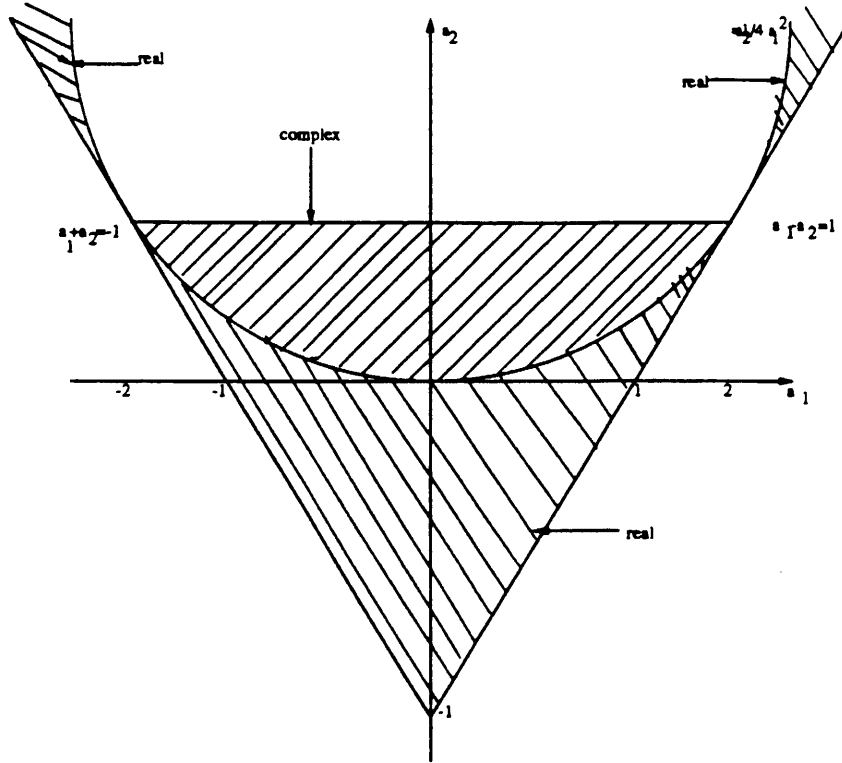

Figure 3.2:

3.43

$$H(z) = \frac{z^{-1} + \frac{1}{2}z^{-2}}{1 - \frac{3}{5}z^{-1} + \frac{2}{25}z^{-2}}$$

(a)

$$H(z) = z^{-1} \left[\frac{-\frac{7}{2}}{1 - \frac{1}{5}z^{-1}} + \frac{\frac{9}{2}}{1 - \frac{2}{5}z^{-1}} \right]$$

$$h(n) = \left[-\frac{7}{2} \left(\frac{1}{5}\right)^{n-1} + \frac{9}{2} \left(\frac{2}{5}\right)^{n-1} \right] u(n-1)$$

(b)

$$Y(z) = H(z)X(z)$$

$$X(z) = \frac{1}{1 - z^{-1}}$$

$$Y(z) = \frac{\frac{25}{8}}{1 - z^{-1}} + \frac{\frac{7}{8}}{1 - \frac{1}{5}z^{-1}} + \frac{-3}{1 - \frac{2}{5}z^{-1}}$$

$$y(n) = \left[\frac{25}{8} + \frac{7}{8} \left(\frac{1}{5}\right)^n - 3 \left(\frac{2}{5}\right)^n \right] u(n)$$

(c) Determine the response caused by the initial conditions and add it to the response in (b).

$$y(n) - \frac{3}{5}y(n-1) + \frac{2}{25}y(n-2) = 0$$

$$Y^+(z) - \frac{3}{5} [Y^+(z)z^{-1} + 1] + \frac{2}{25} [Y^+(z)z^{-2} + z^{-1} + 2] = 0$$

$$Y^+(z) = \frac{\frac{2}{25}z^{-1} - \frac{11}{25}}{(1 - \frac{1}{5}z^{-1})(1 - \frac{2}{5}z^{-1})}$$

$$= \frac{\frac{1}{25}}{1 - \frac{1}{5}z^{-1}} + \frac{\frac{-12}{25}}{1 - \frac{2}{5}z^{-1}}$$

$$y^+(n) = \left[\frac{1}{25} \left(\frac{1}{5}\right)^n - \frac{12}{25} \left(\frac{2}{5}\right)^n \right] u(n)$$

Therefore, the total step response is

$$y(n) = \left[\frac{25}{8} + \frac{33}{200} \left(\frac{1}{5}\right)^n - \frac{87}{25} \left(\frac{2}{5}\right)^n \right] u(n)$$

3.44

$$[aY(z) + X(z)]z^{-2} = Y(z)$$

$$Y(z) = \frac{z^{-2}}{1 - az^{-2}} X(z)$$

Assume that $a > 0$. Then

$$H(z) = -\frac{1}{a} + \frac{\frac{1}{a}}{(1 - \sqrt{a}z^{-1})(1 + \sqrt{a}z^{-1})}$$

$$= -\frac{1}{a} + \frac{1}{2a} \frac{1}{1 - \sqrt{a}z^{-1}} + \frac{1}{2a} \frac{1}{1 + \sqrt{a}z^{-1}}$$

$$h(n) = -\frac{1}{a} \delta(n) + \frac{1}{2a} [(\sqrt{a})^n + (-\sqrt{a})^n] u(n)$$

$$\text{Step Response: } X(z) = \frac{1}{1 - z^{-1}}$$

$$Y(z) = \frac{z^{-2}}{(1 - z^{-1})(1 - \sqrt{a}z^{-1})(1 + \sqrt{a}z^{-1})}$$

$$= \frac{\frac{1}{(a-1)}}{1 - z^{-1}} + \frac{\frac{1}{2(a-\sqrt{a})}}{1 - \sqrt{a}z^{-1}} + \frac{\frac{1}{2(a+\sqrt{a})}}{1 + \sqrt{a}z^{-1}}$$

$$y(n) = \left[\frac{1}{a-1} + \frac{1}{2(a-\sqrt{a})} (\sqrt{a})^n + \frac{1}{2(a+\sqrt{a})} (-\sqrt{a})^n \right] u(n)$$

3.45

$$y(n) = -a_1 y(n-1) + b_0 x(n) + b_1 x(n-1)$$

$$Y(z) = \frac{b_0 + b_1 z^{-1}}{1 + a_1 z^{-1}} X(z)$$

(a)

$$H(z) = \frac{b_0 + b_1 z^{-1}}{1 + a_1 z^{-1}} \Rightarrow h(n) = b_0 (-a_1)^n u(n) + b_1 (-a_1)^{n-1} u(n-1)$$

$$= b_0 + \frac{(b_1 - b_0 a_1) z^{-1}}{1 + a_1 z^{-1}} \Rightarrow h(n) = b_0 \delta(n) + (b_1 - b_0 a_1) (-a_1)^{n-1} u(n-1)$$

(b)

$$\text{Step Response: } X(z) = \frac{1}{1 - z^{-1}}$$

$$\begin{aligned}
Y(z) &= \frac{b_0 + b_1 z^{-1}}{(1 - z^{-1})(1 + a_1 z^{-1})} \\
&= \frac{b_0 + b_1}{1 + a_1} \frac{1}{1 - z^{-1}} + \frac{a_1 b_0 - b_1}{1 + a_1} \frac{1}{1 + a_1 z^{-1}} \\
y(n) &= \left[\frac{b_0 + b_1}{1 + a_1} + \frac{a_1 b_0 - b_1}{1 + a_1} (-a_1)^n \right] u(n)
\end{aligned}$$

(c) Let us compute the zero-input response and add it to the response in (b). Hence,

$$\begin{aligned}
Y^+(z) + a_1 [z^{-1} Y^+(z) + A] &= 0 \\
Y^+(z) &= \frac{-a_1 A}{1 + a_1 z^{-1}} \\
\Rightarrow y_{zi}(n) &= -a_1 A (-a_1)^n u(n)
\end{aligned}$$

The total response to a unit step is

$$y(n) = \left[\frac{b_0 + b_1}{1 + a_1} + \frac{a_1 b_0 - b_1 - a_1 A (1 + a_1)}{1 + a_1} (-a_1)^n \right] u(n)$$

(d)

$$\begin{aligned}
x(n) &= \cos w_0 n u(n) \\
X(z) &= \frac{1 - z^{-1} \cos w_0}{1 - 2z^{-1} \cos w_0 + z^{-2}} \\
Y(z) &= \frac{(b_0 + b_1 z^{-1})(1 - z^{-1} \cos w_0)}{(1 + a_1 z^{-1})(1 - 2z^{-1} \cos w_0 + z^{-2})} \\
&= \frac{A}{1 + a_1 z^{-1}} + \frac{B(1 - z^{-1} \cos w_0)}{1 - 2z^{-1} \cos w_0 + z^{-2}} + \frac{C(z^{-1} \cos w_0)}{1 - 2z^{-1} \cos w_0 + z^{-2}}
\end{aligned}$$

$$\text{Then, } y(n) = [A(-a_1)^n + B \cos w_0 + C \sin w_0] u(n)$$

where A , B and C are determined from the equations

$$\begin{aligned}
A + B &= b_0 \\
(2 \cos w_0)A + (a_1 - \cos w_0)B + (\sin w_0)C &= b_1 - b_0 \cos w_0 \\
A - (a_1 - \cos w_0)B + (\sin w_0)C &= -b_1 \cos w_0
\end{aligned}$$

3.46

$$y(n) = \frac{1}{2}y(n-1) + 4x(n) + 3x(n-1)$$

$$Y(z) = \frac{4 + 3z^{-1}}{1 - \frac{1}{2}z^{-1}} X(z)$$

$$x(n) = e^{jw_0 n} u(n)$$

$$X(z) = \frac{1}{1 - e^{jw_0} z^{-1}}$$

$$Y(z) = \frac{4 + 3z^{-1}}{(1 - \frac{1}{2}z^{-1})(1 - e^{jw_0} z^{-1})}$$

$$Y(z) = \frac{A}{1 - \frac{1}{2}z^{-1}} + \frac{B}{1 - e^{jw_0} z^{-1}}$$

$$\text{where } A = \frac{5}{\frac{1}{2} - e^{jw_0}}$$

$$B = \frac{4e^{j\omega_0} + 3}{e^{j\omega_0} - \frac{1}{2}}$$

$$\text{Then } y(n) = [A(\frac{1}{2})^n + Be^{j\omega_0 n}] u(n)$$

The steady state response is

$$\lim_{n \rightarrow \infty} y(n) \equiv y_{ss}(n) = Be^{j\omega_0 n}$$

3.47

(a)

$$H(z) = C \frac{(z - re^{j\Theta})(z - re^{-j\Theta})}{z(z + 0.8)}$$

$$= C \frac{1 - 2r\cos\Theta z^{-1} + r^2 z^{-2}}{(1 + 0.8z^{-1})}$$

$$H(z)|_{z=1} = 1 \Rightarrow C = \frac{1.8}{1 - 2r\cos\Theta + r^2} = 2.77$$

(b) The poles are inside the unit circle, so the system is stable.

(c) $y(n) = -0.8y(n-1) + Cz(n) - 1.5\sqrt{3}Cx(n-1) + 2.25Cx(n-2)$. Refer to fig 3.3.

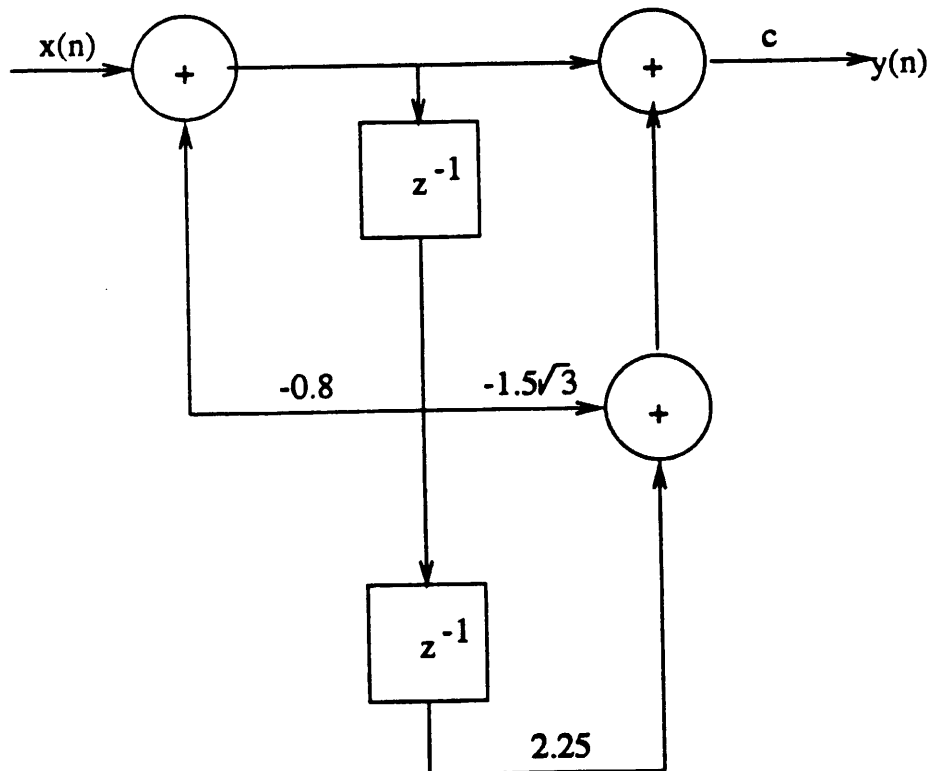

Figure 3.3:

3.48

If $h(n)$ is real, even and has a finite duration $2N + 1$, then (with $M = 2N + 1$)

$$\begin{aligned} H(z) &= h(0) + h(1)z^{-1} + h(2)z^{-2} + \dots + h(M-1)z^{-(M-1)/2} \\ \text{since } h(n) &= h(M-n-1), \text{ then} \\ H(z) &= z^{-(M-1)/2} \left[h(0) \left[z^{(M-1)/2} + z^{-(M-1)/2} \right] \right. \\ &\quad \left. + h(1) \left[z^{(M-3)/2} + z^{-(M-3)/2} \right] + \dots + h(M-1/2) \right] \end{aligned}$$

with $M = 2N + 1$, the expression becomes

$$\begin{aligned} H(z) &= z^{-N} \left[h(0) \left[z^N + z^{-N} \right] \right. \\ &\quad \left. + h(1) \left[z^{N-1} + z^{-(N-1)} \right] \right. \\ &\quad \left. + h(2) \left[z^{N-2} + z^{-(N-2)} \right] + \dots + h(N) \right] \\ &= z^{-N} \left\{ h(N) + \sum_{n=0}^{N-1} h(n)z^{N-n} + \sum_{n=0}^{N-1} h(n)z^{-(N-n)} \right\} \\ &= z^{-N} \{ h(N) + P(z) + P(z^{-1}) \} \end{aligned}$$

Now, suppose z_1 is a root of $H(z)$, i.e.,

$$H(z_1) = z_1^{-N} \{ h(N) + P(z_1) + P(z_1^{-1}) \} = 0$$

$$\text{Then, } h(N) + P(z_1) + P(z_1^{-1}) = 0.$$

This implies that $H(\frac{1}{z_1}) = 0$ since we again have

$$h(N) + P(z_1^{-1}) + P(z_1) = 0.$$

3.49

(a)

$$H(z) = \frac{z-1}{(z+\frac{1}{2})(z+3)(z-2)}, \quad \text{ROC: } \frac{1}{2} < |z| < 2$$

(b) The system can be causal if the ROC is $|z| > 3$, but it cannot be stable.

(c)

$$H(z) = \frac{A}{1+\frac{1}{2}z^{-1}} + \frac{B}{1+3z^{-1}} + \frac{C}{1-2z^{-1}}$$

(1) The system can be causal; (2) The system can be anti-causal; (3) There are two other noncausal responses. The corresponding ROC for each of these possibilities are :

$$\text{ROC}_1 : |z| > 3; \quad \text{ROC}_2 : |z| < 3; \quad \text{ROC}_3 : \frac{1}{2} < |z| < 2; \quad \text{ROC}_4 : 2 < |z| < 3;$$

3.50

$x(n)$ is causal.

(a)

$$\begin{aligned} X(z) &= \sum_{n=0}^{\infty} x(n)z^{-n} \\ \lim_{z \rightarrow \infty} X(z) &= x(0) \end{aligned}$$

(b)(i) $X(z) = \frac{(z-\frac{1}{3})^4}{(z-\frac{1}{3})^3} \Rightarrow \lim_{z \rightarrow \infty} X(z) = \infty \Rightarrow x(n)$ is not causal.

(ii) $X(z) = \frac{(1-\frac{1}{3}z^{-2})^2}{1-\frac{1}{3}z^{-1}} \Rightarrow \lim_{z \rightarrow \infty} X(z) = 1$ Hence $X(z)$ can be associated with a causal sequence.

(iii) $X(z) = \frac{(z-\frac{1}{3})^2}{(z-\frac{1}{3})^3} \Rightarrow \lim_{z \rightarrow \infty} X(z) = 0$. Hence $X(z)$ can be associated with a causal sequence.

3.51

The answer is no. For the given system $h_1(n) = a^n u(n) \Rightarrow H_1(z) = \frac{1}{1-az^{-1}}$, $|a| < 1$. This system is causal and stable. However when $h_2(n) = a^n u(n+3) \Rightarrow H_2(z) = \frac{a^{-3}z^3}{1-az^{-1}}$ the system is stable but is not causal.

3.52

Initial value theorem for anticausal signals: If $x(n)$ is anticausal, then $x(0) = \lim_{z \rightarrow 0} X(z)$

Proof: $X(z) = \sum_{n=-\infty}^0 x(n)z^{-n} = x(0) + x(-1)z + x(-2)z^2 + \dots$ Then $\lim_{z \rightarrow 0} X(z) = x(0)$

3.53

$$s(n) = \left(\frac{1}{3}\right)^{n-2} u(n+2)$$

(a)

$$\begin{aligned} h(n) &= s(n) - s(n-1) \\ &= \left(\frac{1}{3}\right)^{n-2} u(n+2) - \left(\frac{1}{3}\right)^{n-3} u(n+1) \\ &= 3^4 \delta(n+2) - 54 \delta(n+1) - 18 \left(\frac{1}{3}\right)^n u(n) \end{aligned}$$

$$\begin{aligned} H(z) &= 81z^2 - 54z + \frac{-18}{1-\frac{1}{3}z^{-1}} \\ &= \frac{81z(z^{-1})}{1-\frac{1}{3}z^{-1}} \end{aligned}$$

$H(z)$ has zeros at $z = 0, 1$ and a pole at $z = \frac{1}{3}$.

(b) $h(n) = 81\delta(n+2) - 54\delta(n+1) - 18\left(\frac{1}{3}\right)^n u(n)$

(c) The system is not causal, but it is stable since the pole is inside the unit circle.

3.54

(a)

$$\begin{aligned} x(n) &= \frac{1}{2\pi j} \oint_c \frac{z^{n-1}}{1-\frac{1}{2}z^{-1}} dz \\ &= \frac{1}{2\pi j} \oint_c \frac{z^n}{z-\frac{1}{2}} dz \end{aligned}$$

$$\text{for } n \geq 0, x(n) = \left(\frac{1}{2}\right)^n$$

$$\begin{aligned}
\text{for } n < 0, x(-1) &= \frac{1}{2\pi j} \oint_c \frac{1}{z(z - \frac{1}{2})} dz \\
&= \frac{1}{z - \frac{1}{2}} \Big|_{z=0} + \frac{1}{z} \Big|_{z=\frac{1}{2}} = 0 \\
x(-2) &= \frac{1}{2\pi j} \oint_c \frac{1}{z^2(z - \frac{1}{2})} dz \\
&= \frac{d}{dz} \left(\frac{1}{z - \frac{1}{2}} \right) \Big|_{z=0} + \frac{1}{z^2} \Big|_{z=\frac{1}{2}} = 0
\end{aligned}$$

By continuing this process, we find that $x(n) = 0$ for $n < 0$.
(b)

$$\begin{aligned}
X(z) &= \frac{1}{1 - \frac{1}{2}z^{-1}}, |z| < \frac{1}{2} \\
x(n) &= \frac{1}{2\pi j} \oint_c \frac{z^n}{z - \frac{1}{2}} dz, \text{ where } c \text{ is contour of radius less than } \frac{1}{2}
\end{aligned}$$

For $n \geq 0$, there are no poles enclosed in c and, hence, $x(n) = 0$. For $n < 0$, we have

$$\begin{aligned}
x(-1) &= \frac{1}{2\pi j} \oint_c \frac{1}{z(z - \frac{1}{2})} dz \\
&= \frac{1}{z - \frac{1}{2}} \Big|_{z=0} = -2 \\
x(-2) &= \frac{1}{2\pi j} \oint_c \frac{1}{z^2(z - \frac{1}{2})} dz \\
&= \frac{d}{dz} \left(\frac{1}{z - \frac{1}{2}} \right) \Big|_{z=0} = -4
\end{aligned}$$

Alternatively, we may change variables by letting $w = z^{-1}$. Then,

$$\begin{aligned}
x(n) &= -\frac{1}{2\pi j} \oint_{c'} \frac{w^{-n}}{w^{-1} - \frac{1}{2}} \left(-\frac{1}{w^2}\right) dw, \\
&= -\frac{1}{2\pi j} \oint_{c'} \frac{-1}{w^{n+1}(1 - \frac{1}{2}w)} dw \\
&= -\frac{1}{2\pi j} \oint_{c'} \frac{2w^{-n-1}}{w-2} dw \\
&= -(2)^{-n}, \quad n < 0
\end{aligned}$$

(c)

$$\begin{aligned}
X(z) &= \frac{z-a}{1-az}, |z| > \frac{1}{|a|} \\
x(n) &= \frac{1}{2\pi j} \oint_c z^{n-1} \frac{z-a}{1-az} dz, \text{ } c \text{ has a radius greater than } \frac{1}{|a|} \\
&= \frac{1}{2\pi j} \oint_c \frac{-1}{a} \frac{z^{n-1}(z-a)}{z - \frac{1}{a}} dz \\
\text{For } n \geq 0, x(n) &= \frac{-1}{a} \left(\frac{1}{a}\right)^{n-1} \left(\frac{1}{a} - a\right) \\
&= \left(\frac{1}{a}\right)^{n-1} - \left(\frac{1}{a}\right)^{n+1}
\end{aligned}$$

$$\begin{aligned}
\text{For } n = 0, x(n) &= \frac{1}{2\pi j} \oint_c \frac{-1}{a} \frac{(z-a)}{z(z-\frac{1}{a})} dz \\
&= \frac{-1}{a} \left[\frac{-a}{\frac{1}{a}} + \frac{\frac{1}{a}-a}{\frac{1}{a}} \right] \\
&= \frac{-1}{a} (a^2 + 1 - a^2) \\
&= \frac{-1}{a}
\end{aligned}$$

For $n < 0$, we let $w = z^{-1}$. Then

$$\begin{aligned}
x(n) &= \frac{1}{2\pi j} \oint_{c'} \frac{-w^{-n-1}(w^{-1}-a)}{1-aw^{-1}} \left(-\frac{1}{w^2}\right) dw, \\
&= 0, \text{ for } n < 0
\end{aligned}$$

(d)

$$\begin{aligned}
X(z) &= \frac{1 - \frac{1}{4}z^{-1}}{1 - \frac{1}{6}z^{-1} - \frac{1}{6}z^{-2}}, |z| > \frac{1}{2} \\
&= \frac{\frac{3}{10}}{1 - \frac{1}{2}z^{-1}} + \frac{\frac{7}{10}}{1 + \frac{1}{3}z^{-1}} \\
x(n) &= \frac{1}{2\pi j} \oint_c \frac{\frac{3}{10}z^n}{z - \frac{1}{2}} dz + \frac{1}{2\pi j} \oint_c \frac{\frac{7}{10}z^n}{z + \frac{1}{3}} dz
\end{aligned}$$

where the radius of the contour c is greater than $|z| = \frac{1}{2}$. Then, for $n \geq 0$

$$\begin{aligned}
x(n) &= \left[\frac{3}{10} \left(\frac{1}{2}\right)^n + \frac{7}{10} \left(-\frac{1}{3}\right)^n \right] u(n) \\
\text{For } n < 0, x(n) &= 0
\end{aligned}$$

3.55

$$\begin{aligned}
X(z) &= \frac{1-a^2}{(1-az)(1-az^{-1})}, \quad a < |z| < \frac{1}{a}, 0 < a < 1 \\
&= \frac{1}{1-az^{-1}} + \frac{-1}{1-\frac{1}{a}z^{-1}} \\
x(n) &= \frac{1}{2\pi j} \oint_c \frac{z^n}{z-a} dz - \frac{1}{2\pi j} \oint_c \frac{z^n}{z-\frac{1}{a}} dz
\end{aligned}$$

$$\text{For } n \geq 0, \frac{1}{2\pi j} \oint_c \frac{z^n}{z-a} dz = a^n \text{ and}$$

$$\frac{1}{2\pi j} \oint_c \frac{z^n}{z-\frac{1}{a}} dz = 0$$

$$\text{For } n < 0, \frac{1}{2\pi j} \oint_c \frac{z^n}{z-a} dz = 0 \text{ and}$$

$$\frac{1}{2\pi j} \oint_c \frac{z^n}{z-\frac{1}{a}} dz = -a^{-n}$$

3.56

$$X(z) = \frac{z^{20}}{(z-\frac{1}{2})(z-2)^5(z+\frac{5}{2})^2(z+3)}, \frac{1}{2} < |z| < 2$$

$$\begin{aligned}
x(n) &= \frac{1}{2\pi j} \oint_c \frac{z^{n-1} z^{20}}{(z - \frac{1}{2})(z - 2)^5(z + \frac{5}{2})^2(z + 3)} dz \\
x(-18) &= \frac{1}{2\pi j} \oint_c \frac{z}{(z - \frac{1}{2})(z - 2)^5(z + \frac{5}{2})^2(z + 3)} dz \\
&= \frac{\frac{1}{2}}{(\frac{1}{2} - 2)^5(\frac{1}{2} + \frac{5}{2})^2(\frac{1}{2} + 3)} \\
&= \frac{-\frac{1}{2}}{(\frac{3}{2})^5(3)^2(\frac{7}{2})} \\
&= \frac{-2^5}{(3^7)(7)} \\
&= \frac{-32}{15309}
\end{aligned}$$

Chapter 4

4.1

(a) Since $x_a(t)$ is periodic, it can be represented by the fourier series

$$\begin{aligned}
 x_a(t) &= \sum_{k=-\infty}^{\infty} c_k e^{j2\pi kt/\tau} \\
 \text{where } c_k &= \frac{1}{\tau} \int_0^{\tau} A \sin(\pi t/\tau) e^{j2\pi kt/\tau} dt \\
 &= \frac{A}{j2\tau} \int_0^{\tau} [e^{j\pi t/\tau} - e^{-j\pi t/\tau}] e^{-j2\pi kt/\tau} dt \\
 &= \frac{A}{j2\tau} \left[\frac{e^{j\pi(1-2k)t/\tau}}{j\frac{\pi}{2}(1-2k)} - \frac{e^{-j\pi(1+2k)t/\tau}}{-j\frac{\pi}{2}(1+2k)} \right]_0^{\tau} \\
 &= \frac{A}{\pi} \left[\frac{1}{1-2k} + \frac{1}{1+2k} \right] \\
 &= \frac{2A}{\pi(1-4k^2)}
 \end{aligned}$$

$$\begin{aligned}
 \text{Then, } X_a(F) &= \int_{-\infty}^{\infty} x_a(t) e^{-j2\pi(F-\frac{k}{\tau})t} dt \\
 &= \sum_{k=-\infty}^{\infty} c_k \int_{-\infty}^{\infty} e^{-j2\pi(F-\frac{k}{\tau})t} dt \\
 &= \sum_{k=-\infty}^{\infty} c_k \delta(F - \frac{k}{\tau})
 \end{aligned}$$

Hence, the spectrum of $x_a(t)$ consists of spectral lines of frequencies $\frac{k}{\tau}$, $k = 0, \pm 1, \pm 2, \dots$ with amplitude $|c_k|$ and phases $\angle c_k$.

(b) $P_x = \frac{1}{\tau} \int_0^{\tau} x_a^2(t) dt = \frac{1}{\tau} \int_0^{\tau} A^2 \sin^2(\frac{\pi t}{\tau}) dt = \frac{A^2}{2}$

(c) The power spectral density spectrum is $|c_k|^2$, $k = 0, \pm 1, \pm 2, \dots$. Refer to fig 4.1.

(d) Parseval's relation

$$\begin{aligned}
 P_x &= \frac{1}{\tau} \int_0^{\tau} x_a^2(t) dt \\
 &= |c_k|^2 \\
 \sum_{k=-\infty}^{\infty} |c_k|^2 &= \frac{4A^2}{\pi^2} \sum_{k=-\infty}^{\infty} \frac{1}{(4k^2 - 1)^2}
 \end{aligned}$$

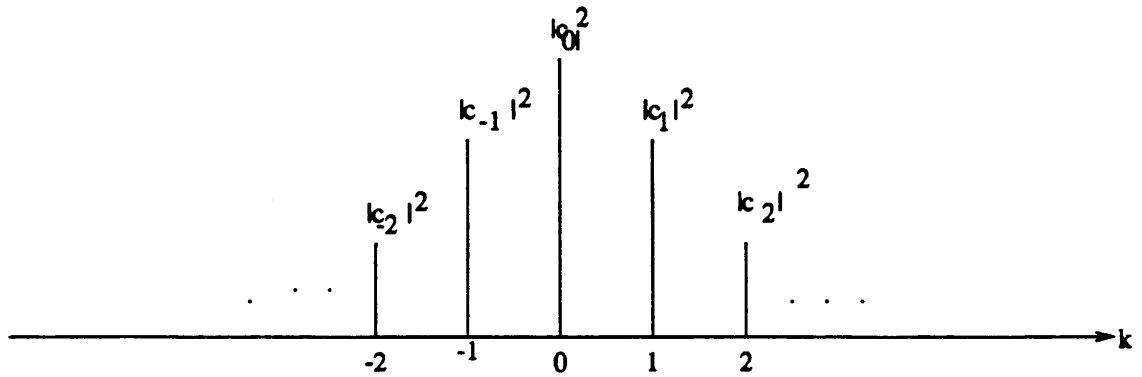

Figure 4.1:

$$\begin{aligned}
 &= \frac{4A^2}{\pi^2} \left[1 + \frac{2}{3^2} + \frac{2}{15^2} + \dots \right] \\
 \left[1 + \frac{2}{3^2} + \frac{2}{15^2} + \dots \right] &= 1.2337 \text{ (Infinite series sum to } \frac{\pi^2}{8} \text{)} \\
 \text{Hence, } \sum_{k=-\infty}^{\infty} |c_k|^2 &= \frac{4A^2}{\pi^2} (1.2337) \\
 &= \frac{A^2}{2}
 \end{aligned}$$

4.2

(a)

$$\begin{aligned}
 x_a(t) &= Ae^{-at}u(t), \quad a > 0 \\
 X_a(F) &= \int_0^{\infty} Ae^{-at}e^{-j2\pi Ft} dt \\
 &= \frac{A}{-a - j2\pi F} e^{-(a+j2\pi F)t} \Big|_0^{\infty} \\
 &= \frac{A}{a + j2\pi F} \\
 |X_a(F)| &= \frac{A}{\sqrt{a^2 + (2\pi F)^2}}
 \end{aligned}$$

$$\angle X_a(F) = -\tan^{-1}\left(\frac{2\pi F}{a}\right)$$

Refer to fig 4.2
(b)

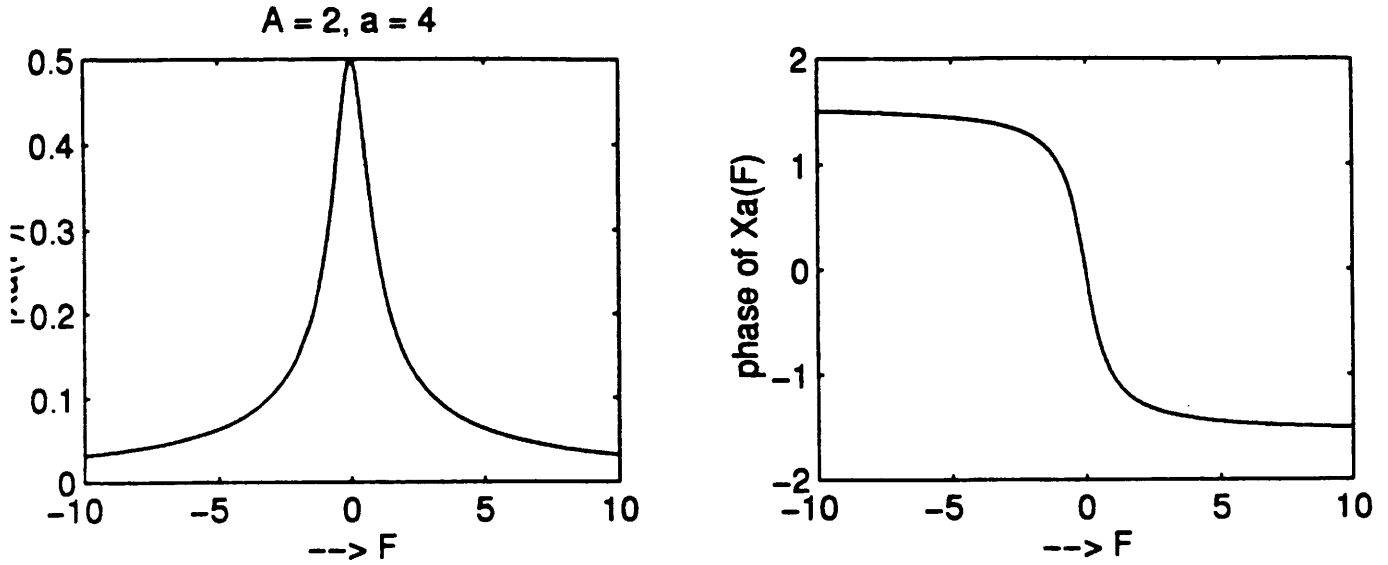

Figure 4.2:

$$\begin{aligned} X_a(F) &= \int_0^{\infty} Ae^{at}e^{-j2\pi Ft} dt + \int_0^{\infty} Ae^{-at}e^{-j2\pi Ft} dt \\ &= \frac{A}{a - j2\pi F} + \frac{A}{a + j2\pi F} \\ &= \frac{2aA}{a^2 + 2\pi F^2} \\ |X_a(F)| &= \frac{2aA}{a^2 + (2\pi F)^2} \\ \angle X_a(F) &= 0 \end{aligned}$$

Refer to fig 4.3

4.3

(a) Refer to fig 4.4.

$$x(t) = \begin{cases} 1 - \frac{|t|}{\tau}, & |t| \leq \tau \\ 0, & \text{otherwise} \end{cases}$$

$$X_a(F) = \int_{-\tau}^0 \left(1 + \frac{t}{\tau}\right) e^{-j2\pi Ft} dt + \int_0^{\tau} \left(1 - \frac{t}{\tau}\right) e^{-j2\pi Ft} dt$$

Alternatively, we may find the fourier transform of

$$y(t) = x'(t) = \begin{cases} \frac{1}{\tau}, & -\tau < t \leq 0 \\ -\frac{1}{\tau}, & 0 < t \leq \tau \end{cases}$$

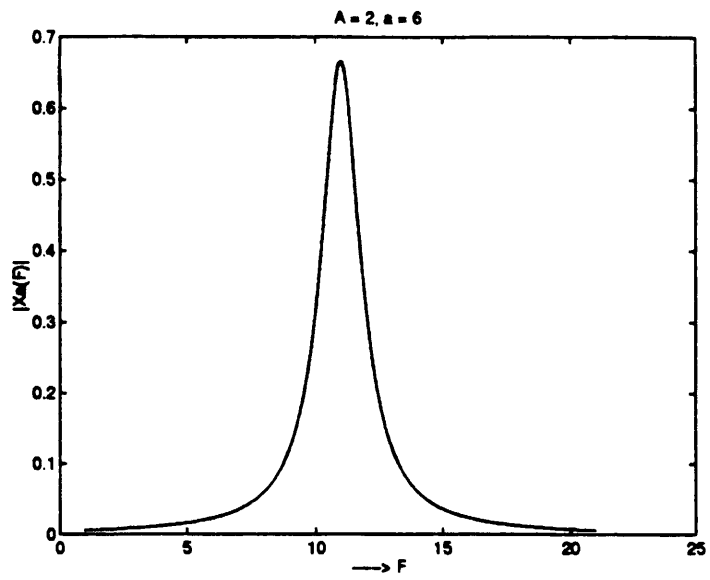

Figure 4.3:

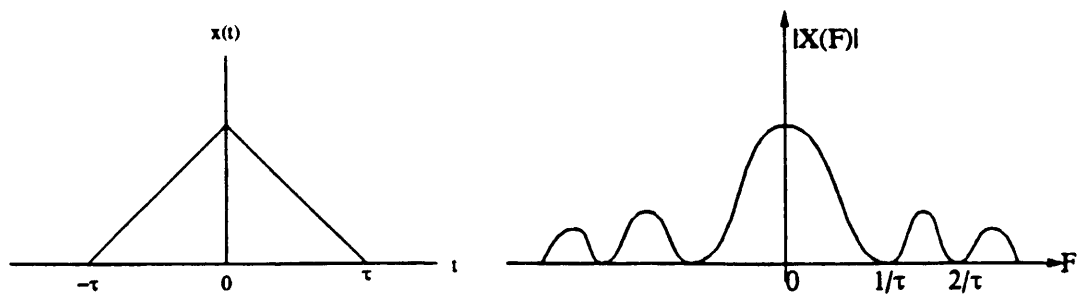

Figure 4.4:

Then,

$$\begin{aligned}
 Y(F) &= \int_{-\tau}^{\tau} y(t)e^{-j2\pi Ft} dt \\
 &= \int_{-\tau}^0 \frac{1}{\tau} e^{-j2\pi Ft} dt + \int_0^{\tau} \left(\frac{-1}{\tau}\right) e^{-j2\pi Ft} dt \\
 &= \frac{2\sin^2 \pi F\tau}{j\pi F\tau} \\
 \text{and } X(F) &= \frac{1}{j2\pi F} Y(F) \\
 &= \tau \left(\frac{\sin \pi F\tau}{\pi F\tau} \right)^2 \\
 |X(F)| &= \tau \left(\frac{\sin \pi F\tau}{\pi F\tau} \right)^2 \\
 \angle X_a(F) &= 0
 \end{aligned}$$

(b)

$$\begin{aligned}
 c_k &= \frac{1}{T_p} \int_{-T_p/2}^{T_p/2} x(t)e^{-j2\pi kt/T_p} dt \\
 &= \frac{1}{T_p} \left[\int_{-\tau}^0 \left(1 + \frac{t}{\tau}\right) e^{-j2\pi kt/T_p} dt + \int_0^{\tau} \left(1 - \frac{t}{\tau}\right) e^{-j2\pi kt/T_p} dt \right] \\
 &= \frac{\tau}{T_p} \left[\frac{\sin \pi k\tau/T_p}{\pi k\tau/T_p} \right]^2
 \end{aligned}$$

(c) From (a) and (b), we have $c_k = \frac{1}{T_p} X_a\left(\frac{k}{T_p}\right)$

4.4

(a)

$$\begin{aligned}
 x(n) &= \left\{ \dots, 1, 0, 1, 2, 3, 2, 1, 0, 1, \dots \right\} \\
 N &= 6 \\
 c_k &= \frac{1}{6} \sum_{n=0}^5 x(n)e^{-j2\pi kn/6} \\
 &= \left[3 + 2e^{\frac{-j2\pi k}{6}} + e^{\frac{-j2\pi k}{3}} + e^{\frac{-j4\pi k}{3}} + 2e^{\frac{-j10\pi k}{6}} \right] \\
 &= \frac{1}{6} \left[3 + 4\cos \frac{\pi k}{3} + 2\cos \frac{2\pi k}{3} \right] \\
 \text{Hence, } c_0 &= \frac{9}{6}, c_1 = \frac{4}{6}, c_2 = 0, c_3 = \frac{1}{6}, c_4 = 0, c_5 = \frac{4}{6}
 \end{aligned}$$

(b)

$$\begin{aligned}
 P_t &= \frac{1}{6} \sum_{n=0}^5 |x(n)|^2 \\
 &= \frac{1}{6} (3^2 + 2^2 + 1^2 + 0^2 + 1^2 + 2^2)
 \end{aligned}$$

$$\begin{aligned}
&= \frac{19}{16} \\
P_f &= \sum_{n=0}^5 |c(n)|^2 \\
&= \left[\left(\frac{9}{16}\right)^2 + \left(\frac{4}{6}\right)^2 + 0^2 + \left(\frac{1}{6}\right)^2 + 0^2 + \left(\frac{4}{6}\right)^2 \right] \\
&= \frac{19}{16} \\
\text{Thus, } P_t &= P_f \\
&= \frac{19}{16}
\end{aligned}$$

4.5

$$x(n) = 2 + 2\cos\pi n/4 + \cos\pi n/2 + \frac{1}{2}\cos 3\pi n/4, \Rightarrow N = 8$$

(a)

$$\begin{aligned}
c_k &= \frac{1}{8} \sum_{n=0}^7 x(n) e^{-j\pi kn/4} \\
x(n) &= \left\{ \frac{11}{2}, 2 + \frac{3}{4}\sqrt{2}, 1, 2 - \frac{3}{4}\sqrt{2}, \frac{1}{2}, 2 - \frac{3}{4}\sqrt{2}, 1, 2 + \frac{3}{4}\sqrt{2} \right\}
\end{aligned}$$

$$\text{Hence, } c_0 = 2, c_1 = c_7 = 1, c_2 = c_6 = \frac{1}{2}, c_3 = c_5 = \frac{1}{4}, c_4 = 0$$

(b)

$$\begin{aligned}
P &= \sum_{i=0}^7 |c(i)|^2 \\
&= 4 + 1 + 1 + \frac{1}{4} + \frac{1}{4} + \frac{1}{16} + \frac{1}{16} \\
&= \frac{53}{8}
\end{aligned}$$

4.6

(a)

$$\begin{aligned}
x(n) &= 4\sin \frac{\pi(n-2)}{3} \\
&= 4\sin \frac{2\pi(n-2)}{6} \\
c_k &= \frac{1}{6} \sum_{n=0}^5 x(n) e^{-2j\pi kn/6} \\
&= \frac{4}{6} \sum_{n=0}^5 \sin \frac{2\pi(n-2)}{6} e^{-2j\pi kn/6} \\
&= \frac{1}{\sqrt{3}} \left[-e^{-j2\pi k/3} - e^{-j\pi k/3} + e^{-j\pi k/3} + e^{-j2\pi k/3} \right]
\end{aligned}$$

$$= \frac{1}{\sqrt{3}}(-j2) \left[\sin \frac{2\pi k}{6} + \sin \frac{\pi k}{3} \right] e^{-j2\pi k/3}$$

Hence, $c_0 = 0, c_1 = -j2e^{-j2\pi/3}, c_2 = c_3 = c_4 = 0, c_5 = c_1^*$
and $|c_1| = |c_5| = 2, |c_0| = |c_2| = |c_3| = |c_4| = 0$

$$\angle c_1 = \pi + \frac{\pi}{2} - \frac{2\pi}{3} = \frac{5\pi}{6}$$

$$\angle c_5 = \frac{-5\pi}{6}$$

$$\angle c_0 = \angle c_2 = \angle c_3 = \angle c_4 = 0$$

(b)

$$x(n) = \cos \frac{2\pi n}{3} + \sin \frac{2\pi n}{5} \Rightarrow N = 15$$

$$c_k = c_{1k} + c_{2k}$$

where c_{1k} is the DTFS coefficients of $\cos \frac{2\pi n}{3}$ and c_{2k} is the DTFS coefficients of $\sin \frac{2\pi n}{5}$. But

$$\cos \frac{2\pi n}{3} = \frac{1}{2} (e^{j\frac{2\pi n}{3}} + e^{-j\frac{2\pi n}{3}})$$

Hence,

$$c_{1k} = \begin{cases} \frac{1}{2}, & k = 5, 10 \\ 0, & \text{otherwise} \end{cases}$$

Similarly,

$$\sin \frac{2\pi n}{5} = \frac{1}{2j} (e^{j\frac{2\pi n}{5}} - e^{-j\frac{2\pi n}{5}})$$

Hence,

$$c_{2k} = \begin{cases} \frac{1}{2j}, & k = 3 \\ \frac{-1}{2j}, & k = 12 \\ 0, & \text{otherwise} \end{cases}$$

Therefore,

$$c_k = c_{1k} + c_{2k} \begin{cases} \frac{1}{2j}, & k = 3 \\ \frac{1}{2}, & k = 5 \\ \frac{1}{2}, & k = 10 \\ \frac{-1}{2j}, & k = 12 \\ 0, & \text{otherwise} \end{cases}$$

(c) $x(n) = \cos \frac{2\pi n}{3} \sin \frac{2\pi n}{5} = \frac{1}{2} \sin \frac{16\pi n}{15} - \frac{1}{2} \sin \frac{4\pi n}{15}$. Hence, $N = 15$. Following the same method as in (b) above, we find that

$$c_k = \begin{cases} \frac{-1}{4j}, & k = 2, 7 \\ \frac{1}{4j}, & k = 8, 13 \\ 0, & \text{otherwise} \end{cases}$$

(d)

$$N = 5$$

$$c_k = \frac{1}{5} \sum_{n=0}^4 x(n) e^{-j2\pi nk/5}$$

$$= \frac{1}{5} \left[e^{-j2\pi k/5} + 2e^{-j4\pi k/5} - 2e^{-j6\pi k/5} - e^{-j8\pi k/5} \right]$$

$$= \frac{2j}{5} \left[-\sin\left(\frac{2\pi k}{5}\right) - 2\sin\left(\frac{4\pi k}{5}\right) \right]$$

Therefore, $c_0 = 0$,

$$c_1 = \frac{2j}{5} \left[-\sin\left(\frac{2\pi}{5}\right) + 2\sin\left(\frac{4\pi}{5}\right) \right]$$

$$c_2 = \frac{2j}{5} \left[\sin\left(\frac{4\pi}{5}\right) - 2\sin\left(\frac{2\pi}{5}\right) \right]$$

$$c_3 = -c_2$$

$$c_4 = -c_1$$

(e)

$$N = 6$$

$$\begin{aligned} c_k &= \frac{1}{6} \sum_{n=0}^5 x(n) e^{-j2\pi nk/6} \\ &= \frac{1}{6} \left[1 + 2e^{-j\pi k/3} - e^{-j2\pi k/3} - e^{-j4\pi k/3} + 2e^{-j5\pi k/3} \right] \\ &= \frac{1}{6} \left[1 + 4\cos\left(\frac{\pi k}{3}\right) - 2\cos\left(\frac{2\pi k}{3}\right) \right] \end{aligned}$$

Therefore, $c_0 = \frac{1}{2}$

$$c_1 = \frac{2}{3}$$

$$c_2 = 0$$

$$c_3 = \frac{-5}{6}$$

$$c_4 = 0$$

$$c_5 = \frac{2}{3}$$

(f)

$$N = 5$$

$$\begin{aligned} c_k &= \frac{1}{5} \sum_{n=0}^4 x(n) e^{-j2\pi nk/5} \\ &= \frac{1}{5} \left[1 + e^{-j2\pi k/5} \right] \\ &= \frac{2}{5} \cos\left(\frac{\pi k}{5}\right) e^{-j\pi k/5} \end{aligned}$$

Therefore, $c_0 = \frac{2}{5}$

$$c_1 = \frac{2}{5} \cos\left(\frac{\pi}{5}\right) e^{-j\pi/5}$$

$$c_2 = \frac{2}{5} \cos\left(\frac{2\pi}{5}\right) e^{-j2\pi/5}$$

$$c_3 = \frac{2}{5} \cos\left(\frac{3\pi}{5}\right) e^{-j3\pi/5}$$

$$c_4 = \frac{2}{5} \cos\left(\frac{4\pi}{5}\right) e^{-j4\pi/5}$$

(g) $N = 1 \quad c_k = x(0) = 1 \text{ or } c_0 = 1$

(h)

$$N = 2$$

$$\begin{aligned}
c_k &= \frac{1}{2} \sum_{n=0}^1 x(n) e^{-j\pi nk} \\
&= \frac{1}{2} (1 - e^{-j\pi k}) \\
\Rightarrow c_0 &= 0, c_1 = 1
\end{aligned}$$

4.7

(a)

$$x(n) = \sum_{k=0}^7 c_k e^{\frac{j2\pi nk}{8}}$$

Note that if $c_k = e^{\frac{j2\pi pk}{8}}$, then

$$\begin{aligned}
\sum_{k=0}^7 e^{\frac{j2\pi pk}{8}} e^{\frac{j2\pi nk}{8}} &= \sum_{n=0}^7 e^{\frac{j2\pi(p+n)k}{8}} \\
&= 8, \quad p = -n \\
&= 0, \quad p \neq -n
\end{aligned}$$

$$\text{Since } c_k = \frac{1}{2} \left[e^{\frac{j2\pi k}{8}} + e^{\frac{-j2\pi k}{8}} \right] + \frac{1}{2j} \left[e^{\frac{j6\pi k}{8}} - e^{\frac{-j6\pi k}{8}} \right]$$

$$\text{We have } x(n) = 4\delta(n+1) + 4\delta(n-1) - 4j\delta(n+3) + 4j\delta(n-3), -3 \leq n \leq 5$$

(b)

$$c_0 = 0, c_1 = \frac{\sqrt{3}}{2}, c_2 = \frac{\sqrt{3}}{2}, c_3 = 0, c_4 = -\frac{\sqrt{3}}{2}, c_5 = -\frac{\sqrt{3}}{2}, c_6 = c_7 = 0$$

$$\begin{aligned}
x(n) &= \sum_{k=0}^7 c_k e^{\frac{j2\pi nk}{8}} \\
&= \frac{\sqrt{3}}{2} \left[e^{\frac{j\pi n}{4}} + e^{\frac{j2\pi n}{4}} - e^{\frac{j4\pi n}{4}} - e^{\frac{j5\pi n}{4}} \right] \\
&= \sqrt{3} \left[\sin \frac{\pi n}{2} + \sin \frac{\pi n}{4} \right] e^{\frac{j\pi(3n-2)}{4}}
\end{aligned}$$

(c)

$$\begin{aligned}
x(n) &= \sum_{k=-3}^4 c_k e^{\frac{j2\pi nk}{8}} \\
&= 2 + e^{\frac{j\pi n}{4}} + e^{\frac{-j\pi n}{4}} + \frac{1}{2} e^{\frac{j\pi n}{2}} + \frac{1}{2} e^{\frac{-j\pi n}{2}} + \frac{1}{4} e^{\frac{j3\pi n}{4}} + \frac{1}{4} e^{\frac{-j3\pi n}{4}} \\
&= 2 + 2\cos \frac{\pi n}{4} + \cos \frac{\pi n}{2} + \frac{1}{2} \cos \frac{3\pi n}{4}
\end{aligned}$$

4.8

(a)

$$\text{If } k = 0, \pm N, \pm 2N, \dots$$

$$\sum_{n=0}^{N-1} e^{j2\pi kn/N} = \sum_{n=0}^{N-1} 1 = N$$

$$\begin{aligned} \text{If } k &\neq 0, \pm N, \pm 2N, \dots \\ \sum_{n=0}^{N-1} e^{j2\pi kn/N} &= \frac{1 - e^{j2\pi k}}{1 - e^{j2\pi k/N}} \\ &= 0 \end{aligned}$$

(b) Refer to fig 4.5.

(c)

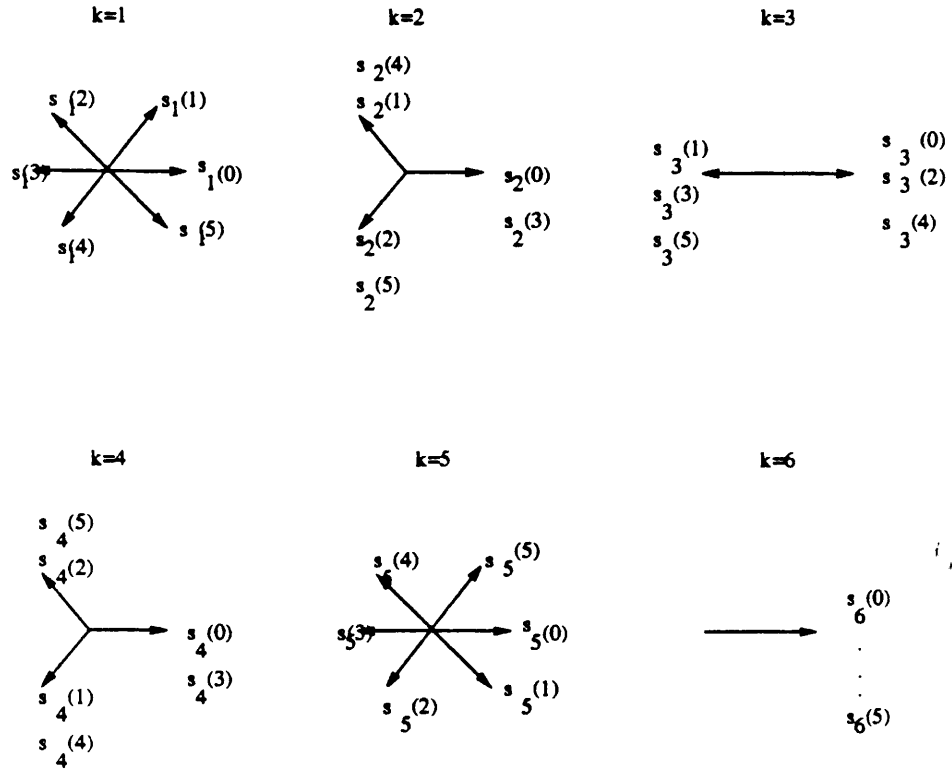

Figure 4.5:

$$\begin{aligned} \sum_{n=0}^{N-1} s_k(n) s_i^*(n) &= \sum_{n=0}^{N-1} e^{j2\pi kn/N} e^{-j2\pi in/N} \\ &= \sum_{n=0}^{N-1} e^{j2\pi(k-i)n/N} \\ &= N, k = i \\ &= 0, k \neq i \end{aligned}$$

Therefore, the $\{s_k(n)\}$ are orthogonal.

4.9

(a)

$$x(n) = u(n) - u(n-6)$$

$$\begin{aligned}
X(w) &= \sum_{n=-\infty}^{\infty} x(n)e^{-jwn} \\
&= \sum_{n=0}^5 e^{-jwn} \\
&= \frac{1 - e^{-j6w}}{1 - e^{-jw}}
\end{aligned}$$

(b)

$$\begin{aligned}
x(n) &= 2^n u(-n) \\
X(w) &= \sum_{n=-\infty}^0 2^n e^{-jwn} \\
&= \sum_{m=0}^{\infty} \left(\frac{e^{jw}}{2}\right)^m \\
&= \frac{2}{2 - e^{jw}}
\end{aligned}$$

(c)

$$\begin{aligned}
x(n) &= \left(\frac{1}{4}\right)^n u(n+4) \\
X(w) &= \sum_{n=-4}^{\infty} \left(\frac{1}{4}\right)^n e^{-jwn} \\
&= \left(\sum_{m=0}^{\infty} \left(\frac{1}{4}\right)^m e^{-jwm}\right) 4^4 e^{j4w} \\
&= \frac{4^4 e^{j4w}}{1 - \frac{1}{4}e^{-jw}}
\end{aligned}$$

(d)

$$\begin{aligned}
x(n) &= \alpha^n \sin w_0 n u(n), |\alpha| < 1 \\
X(w) &= \sum_{n=0}^{\infty} \alpha^n \left[\frac{e^{jw_0 n} - e^{-jw_0 n}}{2j} \right] e^{-jwn} \\
&= \frac{1}{2j} \sum_{n=0}^{\infty} \left[\alpha e^{-j(w-w_0)} \right]^n - \frac{1}{2j} \sum_{n=0}^{\infty} \left[\alpha e^{-j(w+w_0)} \right]^n \\
&= \frac{1}{2j} \left[\frac{1}{1 - \alpha e^{-j(w-w_0)}} - \frac{1}{1 - \alpha e^{-j(w+w_0)}} \right] \\
&= \frac{\alpha \sin w_0 e^{-jw}}{1 - 2\alpha \cos w_0 e^{-jw} + \alpha^2 e^{-j2w}}
\end{aligned}$$

(e)

$$x(n) = |\alpha|^n \sin w_0 n, |\alpha| < 1$$

$$\text{Note that } \sum_{n=-\infty}^{\infty} |x(n)| = \sum_{n=-\infty}^{\infty} |\alpha|^n |\sin w_0 n|$$

Suppose that $w_0 = \frac{\pi}{2}$, so that $|\sin w_0 n| = 1$.

$$\sum_{n=-\infty}^{\infty} |\alpha|^n = \sum_{n=-\infty}^{\infty} |x(n)| \rightarrow \infty.$$

Therefore, the fourier transform does not exist.

(f)

$$x(n) = \begin{cases} 2 - (\frac{1}{2})^n, & |n| \leq 4 \\ 0, & \text{otherwise} \end{cases}$$

$$\begin{aligned} X(w) &= \sum_{n=-4}^4 x(n)e^{-jwn} \\ &= \sum_{n=-4}^4 \left[2 - (\frac{1}{2})^n \right] e^{-jwn} \\ &= \frac{2e^{j4w}}{1 - e^{-jw}} \\ &\quad - \frac{1}{2} [-4e^{j4w} + 4e^{-j4w} - 3e^{j3w} + e^{-j3w} - 2e^{j2w} + 2e^{-j2w} - e^{jw} + e^{-jw}] \\ &= \frac{2e^{j4w}}{1 - e^{-jw}} + j [4\sin 4w + 3\sin 3w + 2\sin 2w + \sin w] \end{aligned}$$

(g)

$$\begin{aligned} X(w) &= \sum_{n=-\infty}^{\infty} x(n)e^{-jwn} \\ &= -2e^{j2w} - e^{jw} + e^{jw} + 2e^{-j2w} \\ &= -2j [2\sin 2w + \sin w] \end{aligned}$$

(h)

$$x(n) = \begin{cases} A(2M + 1 - |n|), & |n| \leq M \\ 0, & |n| > M \end{cases}$$

$$\begin{aligned} X(w) &= \sum_{n=-M}^M x(n)e^{-jwn} \\ &= A \sum_{n=-M}^M (2M + 1 - |n|)e^{-jwn} \\ &= (2M + 1)A + A \sum_{k=1}^M (2M + 1 - k)(e^{-jwk} + e^{jwk}) \\ &= (2M + 1)A + 2A \sum_{k=1}^M (2M + 1 - k)\cos wk \end{aligned}$$

4.10

(a)

$$\begin{aligned} x(n) &= \frac{1}{2\pi} \int_{-\pi}^{\pi} X(w)e^{jwn} dw \\ &= \frac{1}{2\pi} \int_{-\pi}^{-w_0} e^{jwn} dw + \frac{1}{2\pi} \int_{w_0}^{\pi} e^{jwn} dw \\ x(0) &= \frac{1}{2\pi} (\pi - w_0) + \frac{1}{2\pi} (\pi - w_0) \end{aligned}$$

$$\begin{aligned}
&= \frac{\pi - w_0}{\pi} \\
\text{For } n \neq 0, \int_{-\pi}^{-w_0} e^{jwn} dw &= \frac{1}{jn} e^{jwn} \Big|_{-\pi}^{-w_0} \\
&= \frac{1}{jn} (e^{-jw_0 n} - e^{-j\pi n}) \\
\int_{w_0}^{\pi} e^{jwn} dw &= \frac{1}{jn} e^{jwn} \Big|_{w_0}^{\pi} \\
&= \frac{1}{jn} (e^{j\pi n} - e^{jw_0 n}) \\
\text{Hence, } x(n) &= -\frac{\sin n w_0}{n\pi}, n \neq 0
\end{aligned}$$

(b)

$$\begin{aligned}
X(w) &= \cos^2(w) \\
&= \left(\frac{1}{2}e^{jw} + \frac{1}{2}e^{-jw}\right)^2 \\
&= \frac{1}{4}(e^{j2w} + 2 + e^{-j2w}) \\
x(n) &= \frac{1}{2\pi} \int_{-\pi}^{\pi} X(w) e^{jwn} dw \\
&= \frac{1}{8\pi} [2\pi\delta(n+2) + 4\pi\delta(n) + 2\pi\delta(n-2)] \\
&= \frac{1}{4} [\delta(n+2) + 2\delta(n) + \delta(n-2)]
\end{aligned}$$

(c)

$$\begin{aligned}
x(n) &= \frac{1}{2\pi} \int_{-\pi}^{\pi} X(w) e^{jwn} dw \\
&= \frac{1}{2\pi} \int_{w_0 - \frac{\pi}{2}}^{w_0 + \frac{\pi}{2}} e^{jwn} dw \\
&= \frac{2}{\pi} \delta w \left(\frac{\sin(n\delta w/2)}{n\delta w/2} \right) e^{jn w_0}
\end{aligned}$$

(d)

$$\begin{aligned}
x(n) &= \frac{1}{2\pi} \operatorname{Re} \left\{ \int_0^{\pi/8} 2e^{jwn} dw + \int_{\pi/8}^{3\pi/8} e^{jwn} dw + \int_{6\pi/8}^{7\pi/8} e^{jwn} dw + \int_{7\pi/8}^{\pi} e^{jwn} dw \right\} \\
&= \frac{1}{\pi} \left[\int_0^{\pi/8} 2\cos w n dw + \int_{\pi/8}^{3\pi/8} \cos w n dw + \int_{6\pi/8}^{7\pi/8} \cos w n dw + \int_{7\pi/8}^{\pi} 2\cos w n dw \right] \\
&= \frac{1}{n\pi} \left[\sin \frac{7\pi n}{8} + \sin \frac{6\pi n}{8} - \sin \frac{3\pi n}{8} - \sin \frac{\pi n}{8} \right]
\end{aligned}$$

4.11

$$\begin{aligned}
x_e(n) &= \frac{x(n) + x(-n)}{2} \\
&= \left\{ \frac{1}{2}, 0, 1, 2, 1, 0, \frac{1}{2} \right\}
\end{aligned}$$

$$\begin{aligned}
 x_o(n) &= \frac{x(n) - x(-n)}{2} \\
 &= \left\{ \frac{1}{2}, 0, -2, 0, 2, 0, \frac{1}{2} \right\}
 \end{aligned}$$

$$\text{Then, } X_R(w) = \sum_{n=-3}^3 x_e(n)e^{-jwn}$$

$$jX_I(w) = \sum_{n=-3}^3 x_o(n)e^{-jwn}$$

$$\begin{aligned} \text{Now, } Y(w) &= X_I(w) + X_R(w)e^{j2w}. \text{ Therefore,} \\ y(n) &= F^{-1}\{X_I(w)\} + F^{-1}\{X_R(w)e^{j2w}\} \end{aligned}$$

(g)

$$\begin{aligned}
 X(w) &= \sum_{n=-\infty}^{\infty} x(n)e^{-jwn} \\
 &= -2e^{j2w} - e^{jw} + e^{jw} + 2e^{-j2w} \\
 &= -2j[2\sin 2w + \sin w]
 \end{aligned}$$

(h)

$$x(n) = \begin{cases} A(2M+1-|n|), & |n| \leq M \\ 0, & |n| > M \end{cases}$$

$$\begin{aligned}
 X(w) &= \sum_{n=-M}^M x(n)e^{-jwn} \\
 &= A \sum_{n=-M}^M (2M+1-|n|)e^{-jwn} \\
 &= (2M+1)A + A \sum_{k=1}^M (2M+1-k)(e^{-jwk} + e^{jwk}) \\
 &= (2M+1)A + 2A \sum_{k=1}^M (2M+1-k)\cos wk
 \end{aligned}$$

4.12

(a)

$$\begin{aligned}
 x(n) &= \frac{1}{2\pi} \int_{-\pi}^{\pi} X(w)e^{jwn} dw \\
 &= \frac{1}{2\pi} \int_{-\pi}^{-w_0} e^{jwn} dw + \frac{1}{2\pi} \int_{w_0}^{\pi} e^{jwn} dw \\
 x(0) &= \frac{1}{2\pi}(\pi - w_0) + \frac{1}{2\pi}(\pi - w_0) \\
 &= \frac{\pi - w_0}{\pi}
 \end{aligned}$$

$$\text{For } n \neq 0, \int_{-\pi}^{-w_0} e^{jwn} dw = \frac{1}{jn} e^{jwn} \Big|_{-\pi}^{-w_0}$$

$$\begin{aligned}
&= \frac{1}{jn}(e^{-jw_0n} - e^{-j\pi n}) \\
\int_{w_0}^{\pi} e^{jwn} dw &= \frac{1}{jn} e^{jwn} \Big|_{w_0}^{\pi} \\
&= \frac{1}{jn}(e^{j\pi n} - e^{jw_0n})
\end{aligned}$$

$$\text{Hence, } x(n) = -\frac{\sin n w_0}{n\pi}, n \neq 0$$

(b)

$$\begin{aligned}
X(w) &= \cos^2(w) \\
&= \left(\frac{1}{2}e^{jw} + \frac{1}{2}e^{-jw}\right)^2 \\
&= \frac{1}{4}(e^{j2w} + 2 + e^{-j2w}) \\
x(n) &= \frac{1}{2\pi} \int_{-\pi}^{\pi} X(w)e^{jwn} dw \\
&= \frac{1}{8\pi} [2\pi\delta(n+2) + 4\pi\delta(n) + 2\pi\delta(n-2)] \\
&= \frac{1}{4} [\delta(n+2) + 2\delta(n) + \delta(n-2)]
\end{aligned}$$

(c)

$$\begin{aligned}
x(n) &= \frac{1}{2\pi} \int_{-\pi}^{\pi} X(w)e^{jwn} dw \\
&= \frac{1}{2\pi} \int_{w_0 - \frac{\pi}{2}}^{w_0 + \frac{\pi}{2}} e^{jwn} dw \\
&= \frac{2}{\pi} \delta w \left(\frac{\sin(n\delta w/2)}{n\delta w/2} \right) e^{jn w_0}
\end{aligned}$$

(d)

$$\begin{aligned}
x(n) &= \frac{1}{2\pi} \operatorname{Re} \left\{ \int_0^{\pi/8} 2e^{jwn} dw + \int_{\pi/8}^{3\pi/8} e^{jwn} dw + \int_{6\pi/8}^{7\pi/8} e^{jwn} dw + \int_{7\pi/8}^{\pi} e^{jwn} dw \right\} \\
&= \frac{1}{\pi} \left[\int_0^{\pi/8} 2\cos w n dw + \int_{\pi/8}^{3\pi/8} \cos w n dw + \int_{6\pi/8}^{7\pi/8} \cos w n dw + \int_{7\pi/8}^{\pi} 2\cos w n dw \right] \\
&= \frac{1}{n\pi} \left[\sin \frac{7\pi n}{8} + \sin \frac{6\pi n}{8} - \sin \frac{3\pi n}{8} - \sin \frac{\pi n}{8} \right]
\end{aligned}$$

4.13

$$\begin{aligned}
x_e(n) &= \frac{x(n) + x(-n)}{2} \\
&= \left\{ \frac{1}{2}, 0, 1, 2, 1, 0, \frac{1}{2} \right\} \\
x_o(n) &= \frac{x(n) - x(-n)}{2} \\
&= \left\{ \frac{1}{2}, 0, -2, 0, 2, 0, \frac{1}{2} \right\}
\end{aligned}$$

$$\text{Then, } X_R(w) = \sum_{n=-3}^3 x_e(n)e^{-jwn}$$

$$jX_I(w) = \sum_{n=-3}^3 x_o(n)e^{-jwn}$$

Now, $Y(w) = X_I(w) + X_R(w)e^{j2w}$. Therefore,

$$\begin{aligned} y(n) &= F^{-1}\{X_I(w)\} + F^{-1}\{X_R(w)e^{j2w}\} \\ &= -jx_o(n) + x_e(n+2) \\ &= \left\{ \frac{1}{2}, 0, 1 - \frac{j}{2}, 2, 1 + \frac{j}{2}, 0, \frac{1}{2} - j2, 0, \frac{j}{2} \right\} \end{aligned}$$

4.14

(a)

$$\begin{aligned} x(n) &= \frac{1}{2\pi} \left[\int_{8\pi/10}^{9\pi/10} e^{jwn} dw + \int_{-9\pi/10}^{-8\pi/10} e^{jwn} dw + 2 \int_{9\pi/10}^{\pi} e^{jwn} dw + 2 \int_{-\pi}^{-9\pi/10} e^{jwn} dw \right] \\ &= \frac{1}{2\pi} \left[\frac{1}{jn} (e^{j9\pi n/10} - e^{-j9\pi n/10} - e^{j8\pi n/10} + e^{-j8\pi n/10}) \right. \\ &\quad \left. + \frac{2}{jn} (-e^{j9\pi n/10} + e^{-j9\pi n/10} + e^{j\pi n} - e^{-j\pi n}) \right] \\ &= \frac{1}{n\pi} [\sin\pi n - \sin 8\pi n/10 - \sin 9\pi n/10] \\ &= -\frac{1}{n\pi} [\sin 4\pi n/5 + \sin 9\pi n/10] \end{aligned}$$

(b)

$$\begin{aligned} x(n) &= \frac{1}{2\pi} \int_{-\pi}^0 X(w)e^{jwn} dw + \frac{1}{2\pi} \int_0^{\pi} X(w)e^{jwn} dw \\ &= \frac{1}{2\pi} \int_{-\pi}^0 \left(\frac{w}{\pi} + 1 \right) e^{jwn} dw + \frac{1}{2\pi} \int_0^{\pi} \frac{w}{\pi} e^{jwn} dw \\ &= \frac{1}{2\pi} \left[\frac{w}{jn\pi} e^{jwn} \Big|_{-\pi}^0 + \frac{e^{jwn}}{jn} \Big|_{-\pi}^0 \right] \\ &= \frac{1}{\pi n} \sin \frac{\pi n}{2} e^{-jn\pi/2} \end{aligned}$$

(c)

$$\begin{aligned} x(n) &= \frac{1}{2\pi} \int_{w_c - \frac{\pi}{2}}^{w_c + \frac{\pi}{2}} 2e^{jwn} dw + \frac{1}{2\pi} \int_{-w_c - \frac{\pi}{2}}^{-w_c + \frac{\pi}{2}} 2e^{jwn} dw \\ &= \frac{1}{\pi} \left[\frac{1}{jn\pi} e^{jwn} \Big|_{w_c - \frac{\pi}{2}}^{w_c + \frac{\pi}{2}} + \frac{e^{jwn}}{jn} \Big|_{-w_c - \frac{\pi}{2}}^{-w_c + \frac{\pi}{2}} \right] \\ &= \frac{2}{\pi n} \left[\frac{e^{j(w_c + \frac{\pi}{2})n} - e^{j(w_c - \frac{\pi}{2})n} + e^{-j(w_c - \frac{\pi}{2})n} - e^{-j(w_c + \frac{\pi}{2})n}}{2j} \right] \\ &= \frac{2}{\pi n} \left[\sin(w_c + \frac{w}{2})n - \sin(w_c - \frac{w}{2})n \right] \end{aligned}$$

4.15

$$x_1(n) = \begin{cases} 1, & 0 \leq n \leq M \\ 0, & \text{otherwise} \end{cases}$$

$$\begin{aligned} X_1(w) &= \sum_{n=0}^M e^{-jwn} \\ &= \frac{1 - e^{-jw(M+1)}}{1 - e^{-jw}} \end{aligned}$$

$$x_2(n) = \begin{cases} 1, & -M \leq n \leq -1 \\ 0, & \text{otherwise} \end{cases}$$

$$\begin{aligned} X_2(w) &= \sum_{n=-M}^{-1} e^{-jwn} \\ &= \sum_{n=1}^M e^{jwn} \\ &= \frac{1 - e^{jwM}}{1 - e^{jw}} e^{jw} \\ X(w) &= X_1(w) + X_2(w) \\ &= \frac{1 + e^{jw} - e^{jw} - 1 - e^{-jw(M+1)} - e^{jw(M+1)} + e^{jwM} + e^{-jwM}}{2 - e^{-jw} - e^{jw}} \\ &= \frac{2\cos wM - 2\cos w(M+1)}{2 - 2\cos w} \\ &= \frac{2\sin(wM + \frac{w}{2})\cos \frac{w}{2}}{2\sin^2 \frac{w}{2}} \\ &= \frac{\sin(M + \frac{1}{2})w}{\sin(\frac{w}{2})} \end{aligned}$$

4.16

(a) $X(0) = \sum_n x(n) = -1$

(b) $\angle X(w) = \pi$ for all w

(c) $x(0) = \frac{1}{2\pi} \int_{-\pi}^{\pi} X(w)dw$ Hence, $\int_{-\pi}^{\pi} X(w)dw = 2\pi X(0) = -6\pi$

(d)

$$X(\pi) = \sum_{n=-\infty}^{\infty} x(n)e^{-jn\pi} = \sum_n (-1)^n x(n) = -3 - 4 - 2 = -9$$

(e) $\int_{-\pi}^{\pi} |X(w)|^2 dw = 2\pi \sum_n |x(n)|^2 = (2\pi)(19) = 38\pi$

4.17

(a)

$$X(w) = \sum_n x(n)e^{-jwn}$$

$$\begin{aligned}
 X(0) &= \sum_n x(n) \\
 \frac{dX(w)}{dw} \Big|_{w=0} &= -j \sum_n nx(n)e^{-jwn} \Big|_{w=0} \\
 &= -j \sum_n nx(n) \\
 \text{Therefore, } c &= \frac{j \frac{dX(w)}{dw} \Big|_{w=0}}{X(0)}
 \end{aligned}$$

(b) See fig 4.6 $X(0) = 1$ Therefore, $c = \frac{0}{1} = 0$.

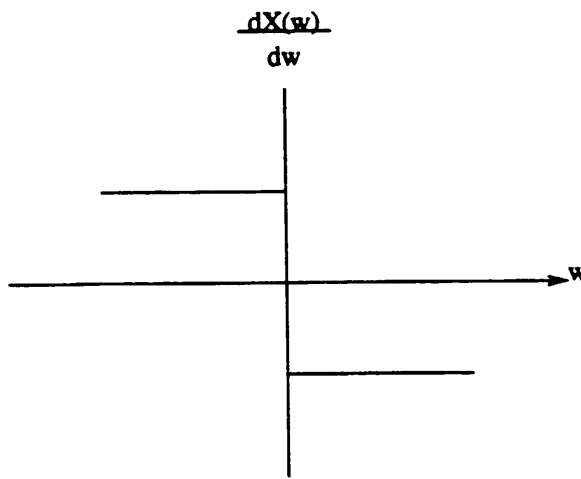

Figure 4.6:

4.18

$$\begin{aligned}
 x_1(n) &\equiv a^n u(n) \\
 \xrightarrow{F} &\frac{1}{1 - ae^{-jw}}
 \end{aligned}$$

Now, suppose that

$$\begin{aligned}
 x_k(n) &= \frac{(n+k-1)!}{n!(k-1)!} a^n u(n) \\
 \xrightarrow{F} &\frac{1}{(1 - ae^{-jw})^k}
 \end{aligned}$$

holds. Then

$$\begin{aligned}
x_{k+1}(n) &= \frac{(n+k)!}{n!k!} a^n u(n) \\
&= \frac{n+k}{k} x_k(n) \\
X_{k+1}(w) &= \frac{1}{k} \sum_n n x_k(n) e^{-jwn} + \sum_n x_k(n) e^{-jwn} \\
&= \frac{1}{k} j \frac{dX_k(w)}{dw} + X_k(w) \\
&= \frac{ae^{-jw}}{(1-ae^{-jw})^{k+1}} + \frac{1}{(1-ae^{-jw})^k}
\end{aligned}$$

4.19

(a)

$$\sum_n x^*(n) e^{-jwn} = \left(\sum_n x(n) e^{-j(-w)n} \right)^* = X^*(-w)$$

(b)

$$\sum_n x^*(-n) e^{-jwn} = \sum_{n=-\infty}^{\infty} x^*(n) e^{jwn} = X^*(w)$$

(c)

$$\begin{aligned}
\sum_n y(n) e^{-jwn} &= \sum_n x(n) e^{-jwn} - \sum_n x(n-1) e^{-jwn} \\
Y(w) &= X(w) + X(w) e^{-jw} \\
&= (1 - e^{-jw}) X(w)
\end{aligned}$$

(d)

$$\begin{aligned}
y(n) &= \sum_{k=-\infty}^n x(k) \\
&= y(n) - y(n-1) \\
&= x(n) \\
\text{Hence, } X(w) &= (1 - e^{-jw}) Y(w) \\
\Rightarrow Y(w) &= \frac{X(w)}{1 - e^{-jw}}
\end{aligned}$$

(e)

$$\begin{aligned}
Y(w) &= \sum_n x(2n) e^{-jwn} \\
&= \sum_n x(n) e^{-j\frac{w}{2}n} \\
&= X\left(\frac{w}{2}\right)
\end{aligned}$$

(f)

$$\begin{aligned}
Y(w) &= \sum_n x\left(\frac{n}{2}\right) e^{-jwn} \\
&= \sum_n x(n) e^{-j2wn} \\
&= X(2w)
\end{aligned}$$

4.20

(a)

$$\begin{aligned} X_1(w) &= \sum_n x(n)e^{-jwn} \\ &= e^{j2w} + e^{jw} + 1 + e^{-jw} + e^{-j2w} \\ &= 1 + 2\cos w + 2\cos 2w \end{aligned}$$

(b)

$$\begin{aligned} X_2(w) &= \sum_n x_2(n)e^{-jwn} \\ &= e^{j4w} + e^{j2w} + 1 + e^{-j2w} + e^{-j4w} \\ &= 1 + 2\cos 2w + 2\cos 4w \end{aligned}$$

(c)

$$\begin{aligned} X_3(w) &= \sum_n x_3(n)e^{-jwn} \\ &= e^{j6w} + e^{j3w} + 1 + e^{-j3w} + e^{-j6w} \\ &= 1 + 2\cos 3w + 2\cos 6w \end{aligned}$$

(d) $X_2(w) = X_1(2w)$ and $X_3(w) = X_1(3w)$. Refer to fig 4.7

(e) If

$$x_k(n) = \begin{cases} x(\frac{n}{k}), & \frac{n}{k} \text{ an integer} \\ 0, & \text{otherwise} \end{cases}$$

Then,

$$\begin{aligned} X_k(w) &= \sum_{n, \frac{n}{k} \text{ an integer}} x_k(n)e^{-jwn} \\ &= \sum_n x(n)e^{-jkw} \\ &= X(kw) \end{aligned}$$

4.21

(a)

$$\begin{aligned} x_1(n) &= \frac{1}{2}(e^{j\pi n/4} + e^{-j\pi n/4})x(n) \\ X_1(w) &= \frac{1}{2} \left[X(w - \frac{\pi}{4}) + X(w + \frac{\pi}{4}) \right] \end{aligned}$$

(b)

$$\begin{aligned} x_2(n) &= \frac{1}{2j}(e^{j\pi n/2} + e^{-j\pi n/2})x(n) \\ X_2(w) &= \frac{1}{2j} \left[X(w - \frac{\pi}{2}) + X(w + \frac{\pi}{2}) \right] \end{aligned}$$

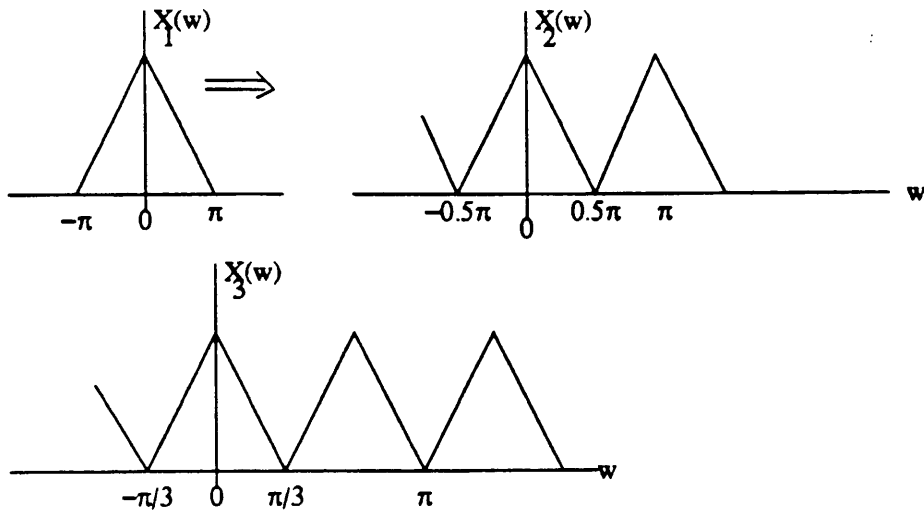

Figure 4.7:

(c)

$$x_3(n) = \frac{1}{2}(e^{j\pi n/2} + e^{-j\pi n/2})x(n)$$

$$X_3(w) = \frac{1}{2} \left[X(w - \frac{\pi}{2}) + X(w + \frac{\pi}{2}) \right]$$

(d)

$$x_4(n) = \frac{1}{2}(e^{j\pi n} + e^{-j\pi n})x(n)$$

$$X_4(w) = \frac{1}{2} [X(w - \pi) + X(w + \pi)]$$

$$= X(w - \pi)$$

4.22

$$c_k^y = \frac{1}{N} \sum_{n=0}^{N-1} y(n) e^{-j2\pi kn/N}$$

$$= \frac{1}{N} \sum_{n=0}^{N-1} \left[\sum_{l=-\infty}^{\infty} x(n - lN) \right] e^{-j2\pi kn/N}$$

$$= \frac{1}{N} \sum_{l=-\infty}^{\infty} \sum_{m=-lN}^{N-1-lN} x(m) e^{-j2\pi k(m+lN)/N}$$

$$\text{But } \sum_{l=-\infty}^{\infty} \sum_{m=-lN}^{N-1-lN} x(m)e^{-j\omega(m+lN)} = X(\omega)$$

$$\text{Therefore, } c_k^y = \frac{1}{N} X\left(\frac{2\pi k}{N}\right)$$

4.23

$$\begin{aligned} \text{Let } x_N(n) &= \frac{\sin \omega_c n}{\pi n}, \quad -N \leq n \leq N \\ &= x(n)w(n) \end{aligned}$$

$$\text{where } x(n) = \frac{\sin \omega_c n}{\pi n}, \quad -\infty \leq n \leq \infty$$

$$\begin{aligned} w(n) &= 1, \quad -N \leq n \leq N \\ &= 0, \quad \text{otherwise} \end{aligned}$$

$$\text{Then } \frac{\sin \omega_c n}{\pi n} \xrightarrow{F} X(\omega)$$

$$\begin{aligned} &= 1, \quad |\omega| \leq \omega_c \\ &= 0, \quad \text{otherwise} \end{aligned}$$

$$X_N(\omega) = X(\omega) * W(\omega)$$

$$\begin{aligned} &= \int_{-\pi}^{\pi} X(\Theta)W(\omega - \Theta)d\Theta \\ &= \int_{-\omega_c}^{\omega_c} \frac{\sin(2N+1)(\omega - \Theta)/2}{\sin(\omega - \Theta)/2} d\Theta \end{aligned}$$

4.24

(a)

$$\begin{aligned} X_1(\omega) &= \sum_n x(2n+1)e^{-j\omega n} \\ &= \sum_k x(k)e^{-j\omega k/2} e^{j\omega/2} \\ &= X\left(\frac{\omega}{2}\right) e^{j\omega/2} \\ &= \frac{e^{j\omega/2}}{1 - ae^{j\omega/2}} \end{aligned}$$

(b)

$$\begin{aligned} X_2(\omega) &= \sum_n x(n+2)e^{j\pi n/2} e^{-j\omega n} \\ &= -\sum_k x(k)e^{-jk(\omega + j\pi/2)} e^{j2\omega} \\ &= -X\left(\omega + \frac{j\pi}{2}\right) e^{j2\omega} \end{aligned}$$

(c)

$$X_3(\omega) = \sum_n x(-2n)e^{-j\omega n}$$

$$\begin{aligned}
&= -\sum_k x(k)e^{-jk\omega/2} \\
&= X\left(-\frac{\omega}{2}\right)
\end{aligned}$$

(d)

$$\begin{aligned}
X_4(\omega) &= \sum_n \frac{1}{2}(e^{j0.3\pi n} + e^{-j0.3\pi n})x(n)e^{-j\omega n} \\
&= \frac{1}{2} \sum_n x(n) \left[e^{-j(\omega-0.3\pi)n} + e^{-j(\omega+0.3\pi)n} \right] \\
&= \frac{1}{2} [X(\omega - 0.3\pi) + X(\omega + 0.3\pi)]
\end{aligned}$$

(e) $X_5(\omega) = X(\omega) [X(\omega)e^{-j\omega}] = X^2(\omega)e^{-j\omega}$
(f)

$$\begin{aligned}
X_6(\omega) &= X(\omega)X(-\omega) \\
&= \frac{1}{(1 - ae^{-j\omega})(1 - ae^{j\omega})} \\
&= \frac{1}{(1 - 2a\cos\omega + a^2)}
\end{aligned}$$

4.25

(a) $Y_1(\omega) = \sum_n y_1(n)e^{-j\omega n} = \sum_{n, n \text{ even}} x(n)e^{-j\omega n}$ The fourier transform $Y_1(\omega)$ can easily be obtained by combining the results of (b) and (c).

(b)

$$\begin{aligned}
y_2(n) &= x(2n) \\
Y_2(\omega) &= \sum_n y_2(n)e^{-j\omega n} \\
&= \sum_n x(2n)e^{-j\omega n} \\
&= \sum_m x(m)e^{-j\omega m/2} \\
&= X\left(\frac{\omega}{2}\right)
\end{aligned}$$

Refer to fig 4.8.

(c)

$$y_3(n) = \begin{cases} x(n/2), & n \text{ even} \\ 0, & \text{otherwise} \end{cases}$$

$$\begin{aligned}
Y_3(\omega) &= \sum_n y_3(n)e^{-j\omega n} \\
&= \sum_{n \text{ even}} x(n/2)e^{-j\omega n} \\
&= \sum_m x(m)e^{-j2\omega m} \\
&= X(2\omega)
\end{aligned}$$

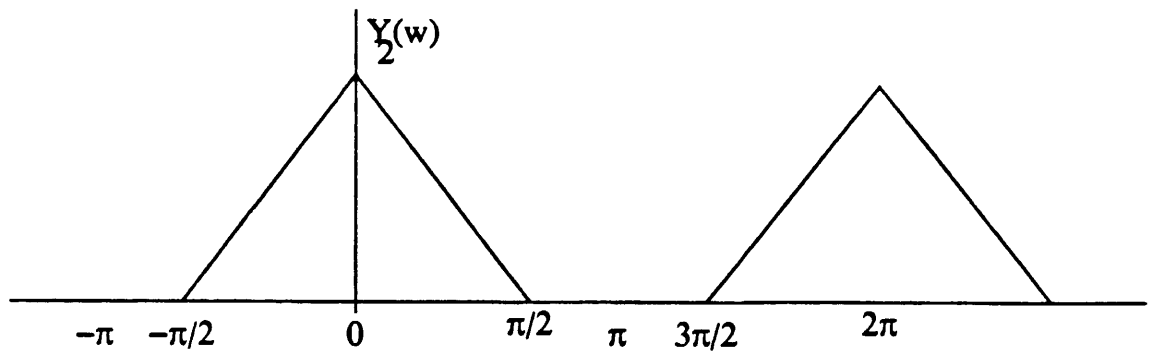

Figure 4.8:

We now return to part(a). Note that $y_1(n)$ may be expressed as

$$y_1(n) = \begin{cases} y_2(n/2), & n \text{ even} \\ 0, & n \text{ odd} \end{cases}$$

Hence, $Y_1(w) = Y_2(2w)$. Refer to fig 4.9.

4.26

(a) Because the range of n is $(-\infty, \infty)$, the fourier transforms of $x(n)$ and $y(n)$ do not exist. However, the relationship implied by the forms of $x(n)$ and $y(n)$ is $y(n) = x^3(n)$. In this case, the system H_1 is non-linear.

(b) In this case,

$$\begin{aligned} X(w) &= \frac{1}{1 - \frac{1}{2}e^{-jw}}, \\ Y(w) &= \frac{1}{1 - \frac{1}{8}e^{-jw}}, \\ \text{Hence, } H(w) &= \frac{Y(w)}{X(w)} \\ &= \frac{1 - \frac{1}{2}e^{-jw}}{1 - \frac{1}{8}e^{-jw}} \\ &\Rightarrow \text{System is LTI} \end{aligned}$$

Note however that the system may also be nonlinear, e.g., $y(n) = x^3(n)$. (c) and (d). Clearly, there is an LTI system that produces $y(n)$ when excited by $x(n)$, e.g. $H(w) = 3$, for all w , or $H(\frac{\pi}{5}) = 3$.

(e) If this system is LTI, the period of the output signal would be the same as the period of the input signal, i.e., $N_1 = N_2$. Since this is not the case, the system is nonlinear.

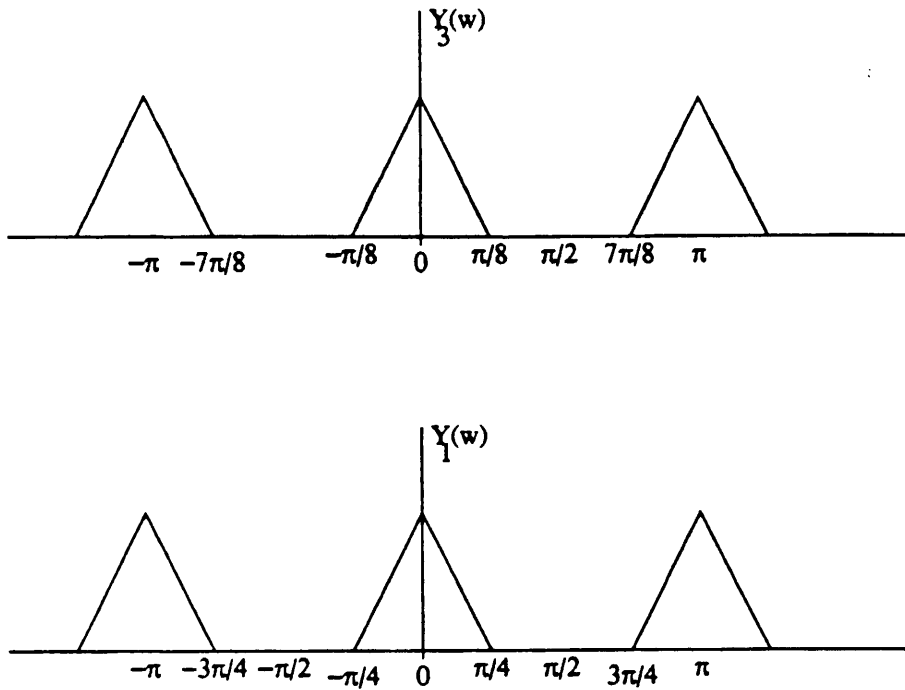

Figure 4.9:

4.27

(a)

$$\begin{aligned}
 W_R(w) &= \sum_{n=0}^M w_R(n) e^{-jwn} \\
 &= \sum_{n=0}^M e^{-jwn} \\
 &= \frac{1 - e^{-j(M+1)w}}{1 - e^{-jw}} \\
 &= e^{-jMw/2} \frac{\sin\left(\frac{M+1}{2}w\right)}{\sin\frac{w}{2}}
 \end{aligned}$$

(b) Let $w_T(n) = h_R(n) * h_R(n-1)$,

$$h_R(n) = \begin{cases} 1, & 0 \leq n \leq \frac{M}{2} - 1 \\ 0, & \text{otherwise} \end{cases}$$

Hence,

$$\begin{aligned}
 W_T(w) &= H_R^2(w) e^{-jw} \\
 &= \left(\frac{\sin\frac{M}{4}w}{\sin\frac{w}{2}} \right)^2 e^{-jwM/2}
 \end{aligned}$$

(c)

$$\begin{aligned}\text{Let } c(n) &= \frac{1}{2} \left(1 + \cos \frac{2\pi n}{M} \right) \\ \text{Then, } C(w) &= \pi \left[\delta(w) + \frac{1}{2} \delta\left(w - \frac{2\pi}{M}\right) + \frac{1}{2} \delta\left(w + \frac{2\pi}{M}\right) \right] \quad -\pi \leq w \leq \pi \\ W_c(w) &= \frac{1}{2\pi} \int_{-\pi}^{\pi} c(\Theta) W_R(w - \Theta) d\Theta \\ &= \frac{1}{2} W_R(w) + \frac{1}{2} W_R\left(w - \frac{2\pi}{M}\right) + \frac{1}{2} W_R\left(w + \frac{2\pi}{M}\right)\end{aligned}$$

Refer to fig 4.10

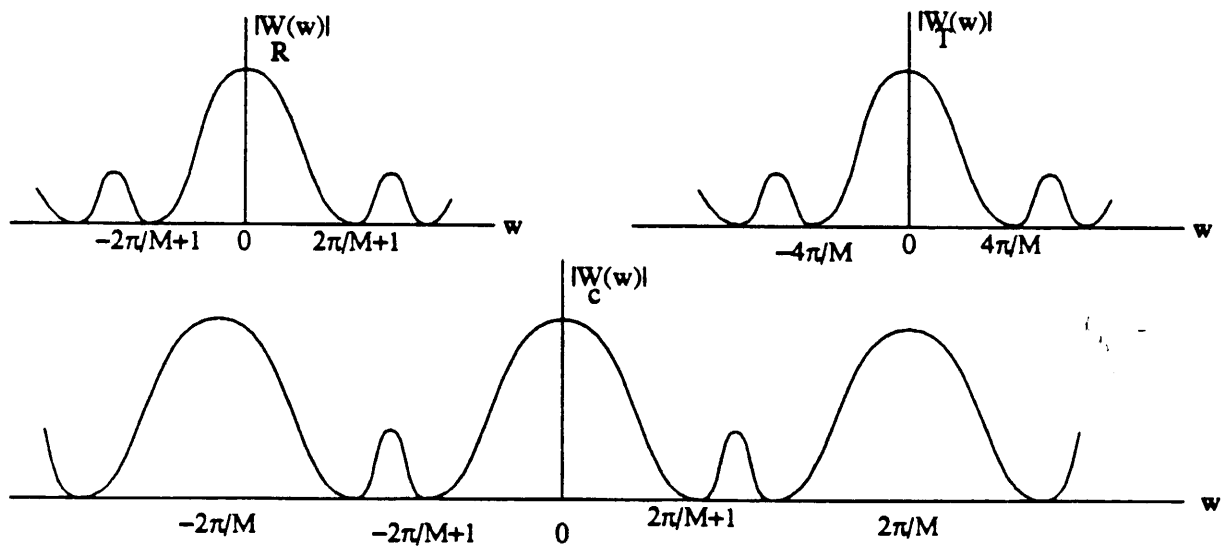

Figure 4.10:

4.28

(a)

$$\begin{aligned}h(n) &= \left(\frac{1}{2}\right)^n u(n) \\ H(w) &= \sum_{n=0}^{\infty} \left(\frac{1}{2}\right)^n e^{-jwn} \\ &= \sum_{n=0}^{\infty} \left(\frac{1}{2} e^{-jw}\right)^n\end{aligned}$$

$$\begin{aligned}
&= \frac{1}{1 - \frac{1}{2}e^{-j\omega}} \\
|H(\omega)| &= \frac{1}{\left[\left(1 - \frac{1}{2}\cos\omega\right)^2 + \left(\frac{1}{2}\sin\omega\right)^2\right]^{\frac{1}{2}}} \\
&= \frac{1}{\left[\frac{5}{4} - \cos\omega\right]^{\frac{1}{2}}} \\
\angle H(\omega) &= -\tan^{-1} \frac{\frac{1}{2}\sin\omega}{1 - \frac{1}{2}\cos\omega} \\
&\equiv \Theta(\omega)
\end{aligned}$$

(b)

$$\begin{aligned}
\text{For the input } x(n) &= \cos \frac{3\pi}{10}n \\
&= \frac{1}{2} \left(e^{j\frac{3\pi}{10}n} + e^{-j\frac{3\pi}{10}n} \right) \\
X(\omega) &= \pi \left[\delta\left(\omega - \frac{3\pi}{10}\right) + \delta\left(\omega + \frac{3\pi}{10}\right) \right], |\omega| \leq \pi \\
Y(\omega) &= H(\omega)X(\omega) \\
&= H\left(\frac{3\pi}{10}\right)\pi \left[\delta\left(\omega - \frac{3\pi}{10}\right) + \delta\left(\omega + \frac{3\pi}{10}\right) \right] \\
y(n) &= |H\left(\frac{3\pi}{10}\right)| \cos \left[\frac{3\pi n}{10} + \Theta\left(\frac{3\pi}{10}\right) \right]
\end{aligned}$$

(c)

$$\begin{aligned}
x(n) &= \left\{ \dots, 1, 1, 0, \underset{\uparrow}{1}, 1, 1, 0, 1, 1, 1, 0, \dots \right\} \\
\text{First, determine } x_e(n) &= \frac{x(n) + x(-n)}{2} \\
\text{and } x_o(n) &= \frac{x(n) - x(-n)}{2} \\
\text{Then, } X_R(\omega) &= \sum_n x_e(n)e^{-j\omega n} \\
X_I(\omega) &= \sum_n x_o(n)e^{-j\omega n} \\
|H(\omega)| &= [X_R^2(\omega) + X_I^2(\omega)]^{\frac{1}{2}}, \\
\Theta(\omega) &= \tan^{-1} \frac{X_I(\omega)}{X_R(\omega)} \\
\text{and } Y(\omega) &= H(\omega)X(\omega)
\end{aligned}$$

4.29

(a)

$$\begin{aligned}
y(n) &= \frac{x(n) + x(n-1)}{2} \\
Y(\omega) &= \frac{1}{2}(1 + e^{-j\omega})X(\omega)
\end{aligned}$$

$$\begin{aligned}
 H(w) &= \frac{1}{2}(1 + e^{-jw}) \\
 &= \left(\cos\frac{w}{2}\right)e^{-jw/2}
 \end{aligned}$$

Refer to fig 4.11.
(b)

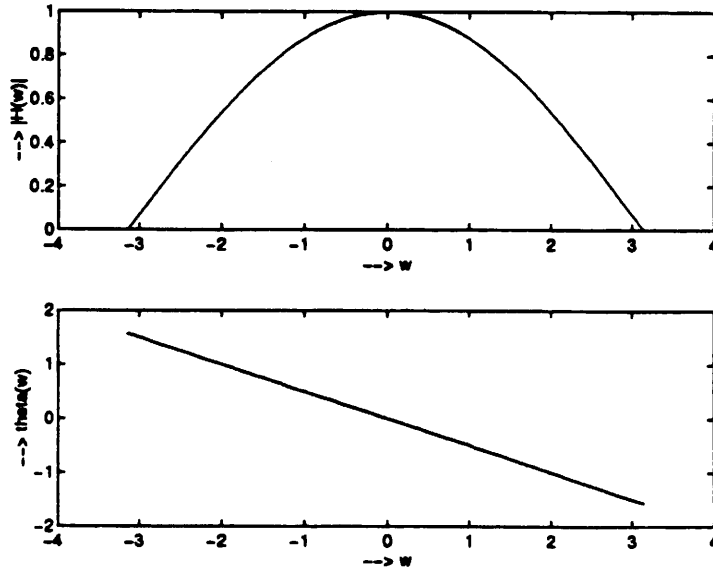

Figure 4.11:

$$\begin{aligned}
 y(n) &= \frac{x(n) - x(n-1)}{2} \\
 Y(w) &= \frac{1}{2}(1 - e^{-jw})X(w) \\
 H(w) &= \frac{1}{2}(1 - e^{-jw}) \\
 &= \left(\sin\frac{w}{2}\right)e^{-jw/2}e^{j\pi/2}
 \end{aligned}$$

Refer to fig 4.12.
(c)

$$\begin{aligned}
 y(n) &= \frac{x(n+1) - x(n-1)}{2} \\
 Y(w) &= \frac{1}{2}(e^{jw} - e^{-jw})X(w) \\
 H(w) &= \frac{1}{2}(e^{jw} - e^{-jw}) \\
 &= (\sin w)e^{j\pi/2}
 \end{aligned}$$

Refer to fig 4.13.
(d)

$$y(n) = \frac{x(n+1) + x(n-1)}{2}$$

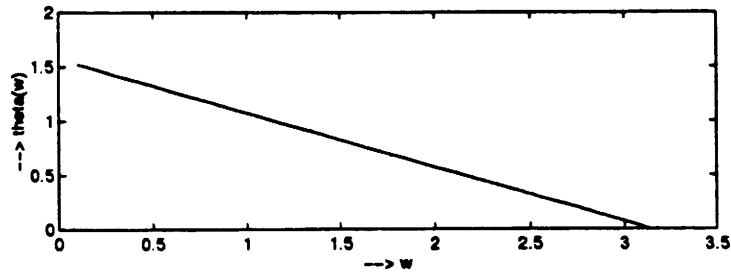
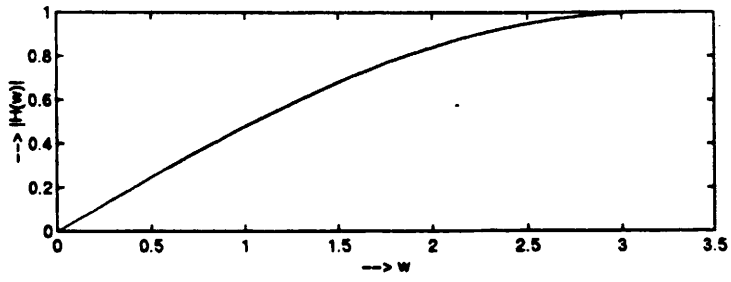

Figure 4.12:

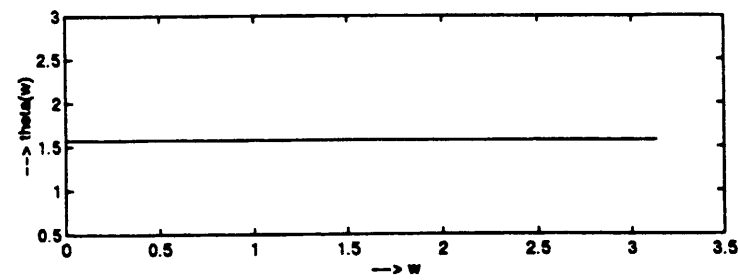
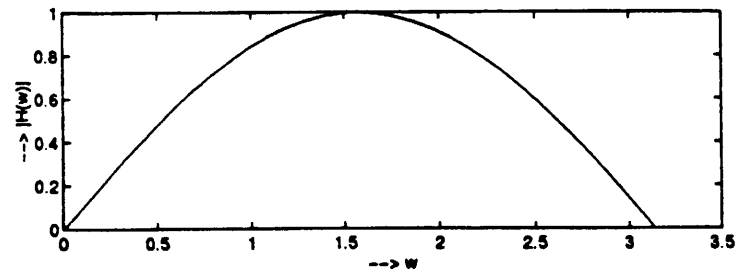

Figure 4.13:

$$Y(w) = \frac{1}{2}(e^{jw} + e^{-jw})X(w)$$

$$H(w) = \frac{1}{2}(e^{jw} + e^{-jw})$$

$$= \cos w$$

Refer to fig 4.14 (e)

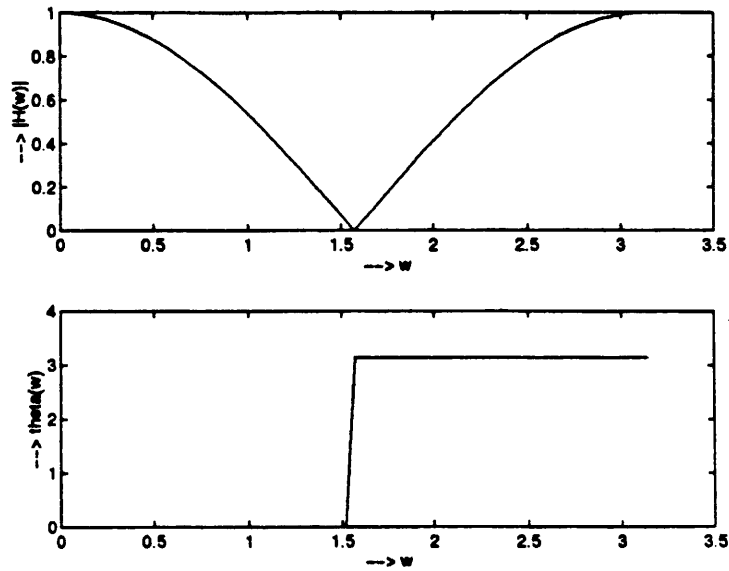

Figure 4.14:

$$y(n) = \frac{x(n) + x(n-2)}{2}$$

$$Y(w) = \frac{1}{2}(1 + e^{-j2w})X(w)$$

$$H(w) = \frac{1}{2}(1 + e^{-j2w})$$

$$= (\cos w)e^{-jw}$$

Refer to fig 4.15.
(f)

$$y(n) = \frac{x(n) - x(n-2)}{2}$$

$$Y(w) = \frac{1}{2}(1 - e^{-j2w})X(w)$$

$$H(w) = \frac{1}{2}(1 - e^{-j2w})$$

$$= (\sin w)e^{-jw + j\pi/2}$$

Refer to fig 4.16 (g)

$$y(n) = \frac{x(n) + x(n-1) + x(n-2)}{3}$$

$$Y(w) = \frac{1}{3}(1 + e^{-jw} + e^{-j2w})X(w)$$

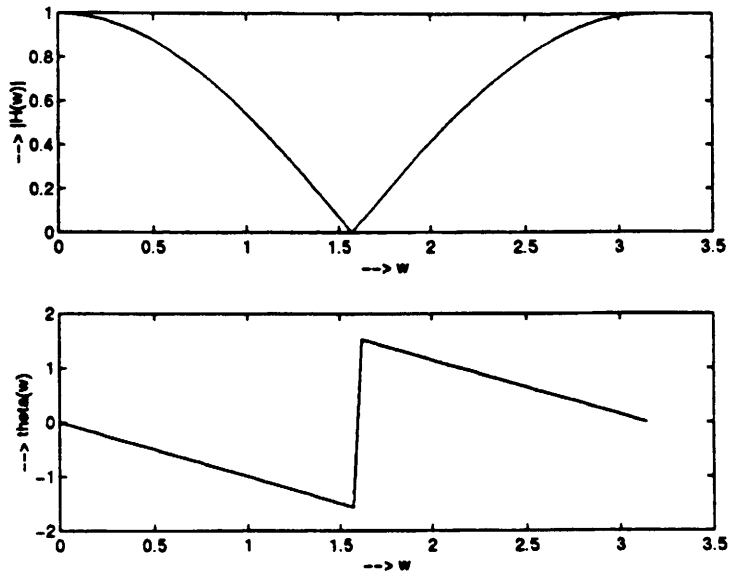

Figure 4.15:

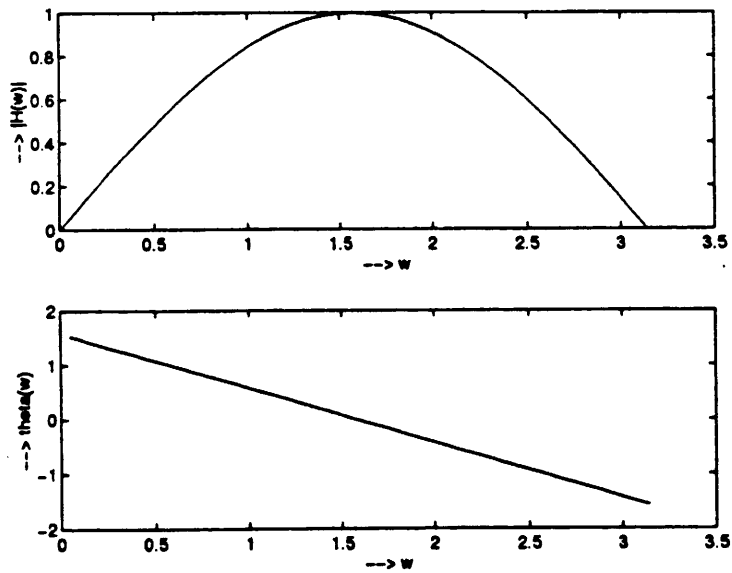

Figure 4.16:

$$\begin{aligned}
 H(w) &= \frac{1}{3}(1 + e^{-jw} + e^{-j2w}) \\
 &= \frac{1}{3}(1 + e^{jw} + e^{-jw})e^{-jw} \\
 &= \frac{1}{3}(1 + 2\cos w)e^{-jw} \\
 |H(w)| &= \left| \frac{1}{3}(1 + 2\cos w) \right|
 \end{aligned}$$

$$\angle H(w) = \begin{cases} -w, & 1 + 2\cos w > 0 \\ \pi - w, & 1 + 2\cos w < 0 \end{cases}$$

Refer to fig 4.17.

(h)

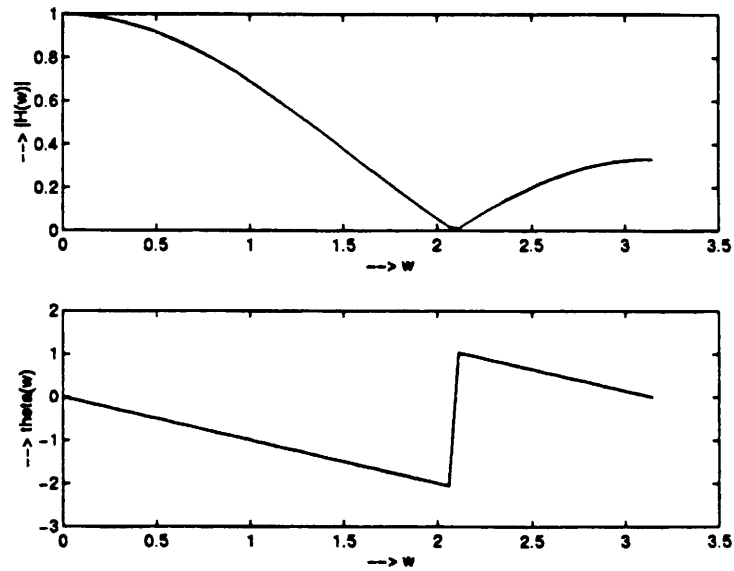

Figure 4.17:

$$\begin{aligned}
 y(n) &= x(n) - x(n-8) \\
 Y(w) &= (1 - e^{-j8w})X(w) \\
 H(w) &= (1 - e^{-j8w}) \\
 &= 2(\sin 4w)e^{j(\pi/2-4w)}
 \end{aligned}$$

Refer to fig 4.18.

(i)

$$\begin{aligned}
 y(n) &= 2x(n-1) - x(n-2) \\
 Y(w) &= (2e^{-jw} - e^{-j2w})X(w) \\
 H(w) &= (2e^{-jw} - e^{-j2w}) \\
 &= 2\cos w - \cos 2w - j(2\sin w - \sin 2w) \\
 |H(w)| &= [(2\cos w - \cos 2w)^2 + (2\sin w - \sin 2w)^2]^{\frac{1}{2}} \\
 \Theta(w) &= -\tan^{-1} \left(\frac{2\sin w - \sin 2w}{2\cos w - \cos 2w} \right)
 \end{aligned}$$

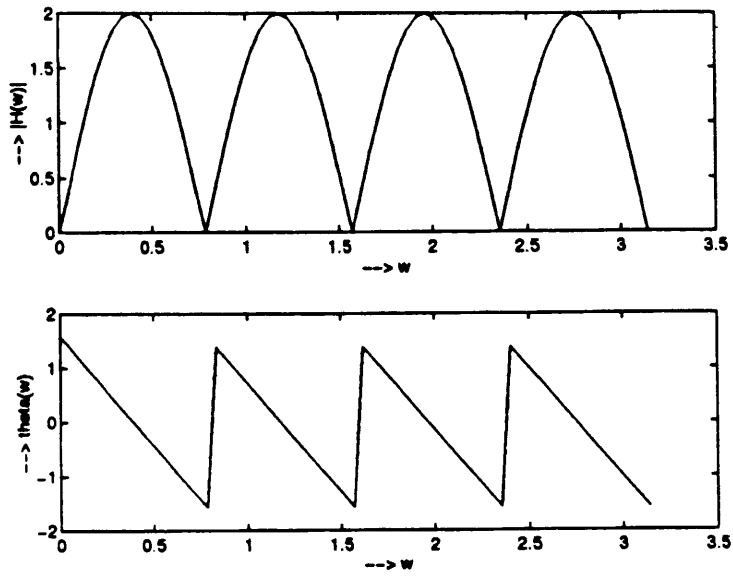

Figure 4.18:

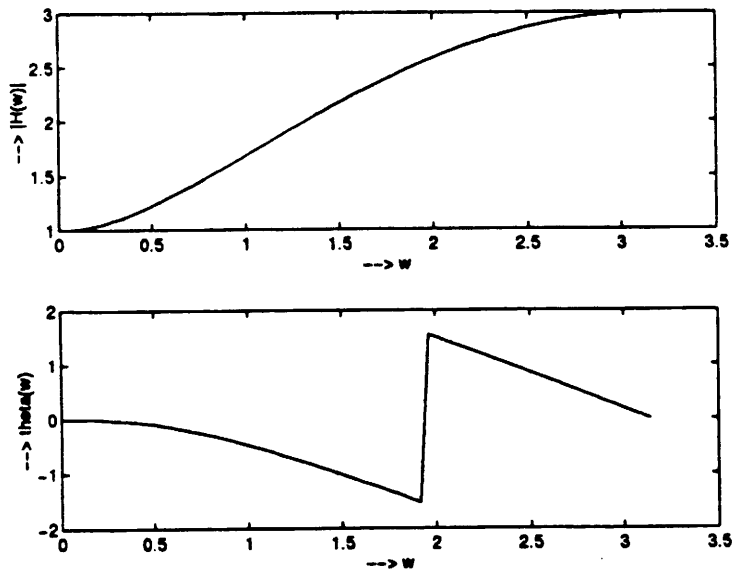

Figure 4.19:

Refer to fig 4.19.

(j)

$$\begin{aligned}
 y(n) &= \frac{x(n) + x(n-1) + x(n-2) + x(n-3)}{4} \\
 Y(w) &= \frac{1}{4}(1 + e^{-jw} + e^{-j2w} + e^{-j3w})X(w) \\
 H(w) &= \frac{1}{3} [e^{-jw}(e^{jw} + e^{-jw}) + e^{-j2w}(e^{jw} + e^{-jw})] \\
 &= \frac{1}{2}(e^{-jw} + e^{-j2w})\cos w \\
 &= (\cos w)\left(\cos \frac{w}{2}\right)e^{-j3w/2}
 \end{aligned}$$

Refer to fig 4.20.

(k)

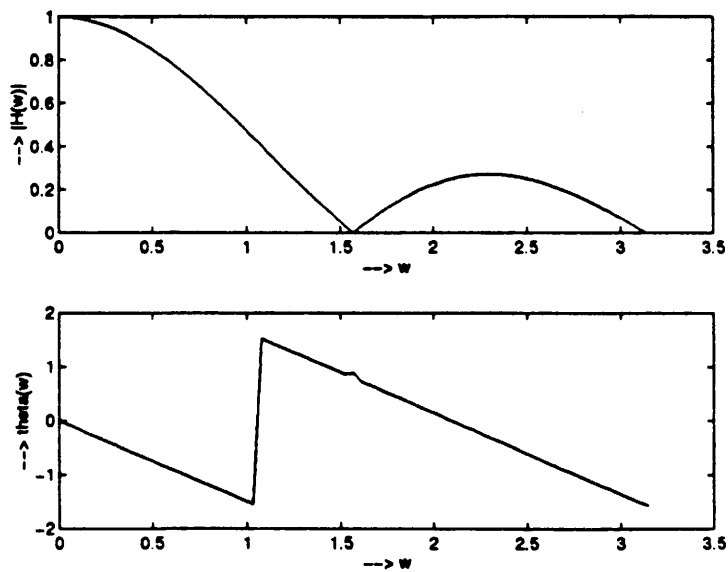

Figure 4.20:

$$\begin{aligned}
 y(n) &= \frac{x(n) + 3x(n-1) + 3x(n-2) + x(n-3)}{8} \\
 Y(w) &= \frac{1}{8}(1 + 3e^{-jw} + 3e^{-j2w} + e^{-j3w})X(w) \\
 H(w) &= \frac{1}{8}(1 + e^{-jw})^3 \\
 &= (\cos w/2)^3 e^{-j3w/2}
 \end{aligned}$$

Refer to fig 4.21.

(l)

$$\begin{aligned}
 y(n) &= x(n-4) \\
 Y(w) &= e^{-j4w}X(w) \\
 H(w) &= e^{-j4w} \\
 |H(w)| &= 1 \\
 \Theta(w) &= -4w
 \end{aligned}$$

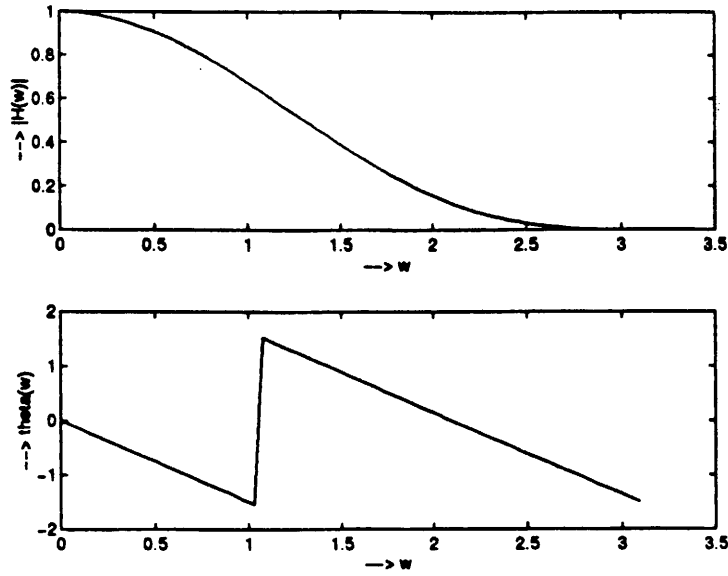

Figure 4.21:

Refer to fig 4.22.
(m)

$$\begin{aligned}
 y(n) &= x(n+4) \\
 Y(w) &= e^{j4w} X(w) \\
 H(w) &= e^{j4w} \\
 |H(w)| &= 1 \\
 \Theta(w) &= 4w
 \end{aligned}$$

Refer to fig 4.23.
(n)

$$\begin{aligned}
 y(n) &= \frac{x(n) - 2x(n-1) + x(n-2)}{4} \\
 Y(w) &= \frac{1}{4}(1 - 2e^{-jw} + e^{-j2w})X(w) \\
 H(w) &= \frac{1}{4}(1 - e^{-jw})^2 \\
 &= (\sin^2 w/2)e^{-j(w-\pi)}
 \end{aligned}$$

Refer to fig 4.24.

4.30

(a)

$$\begin{aligned}
 y(n) &= x(n) + x(n-10) \\
 Y(w) &= (1 + e^{-j10w})X(w) \\
 H(w) &= (2\cos 5w)e^{-j5w}
 \end{aligned}$$

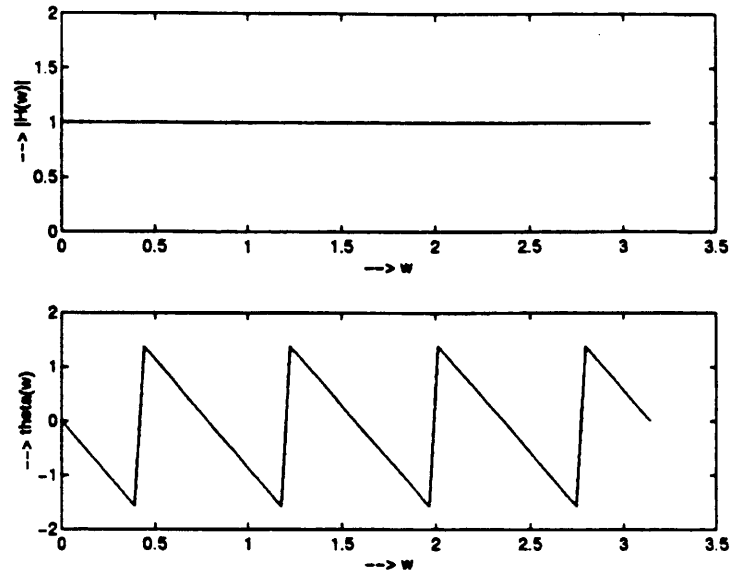

Figure 4.22:

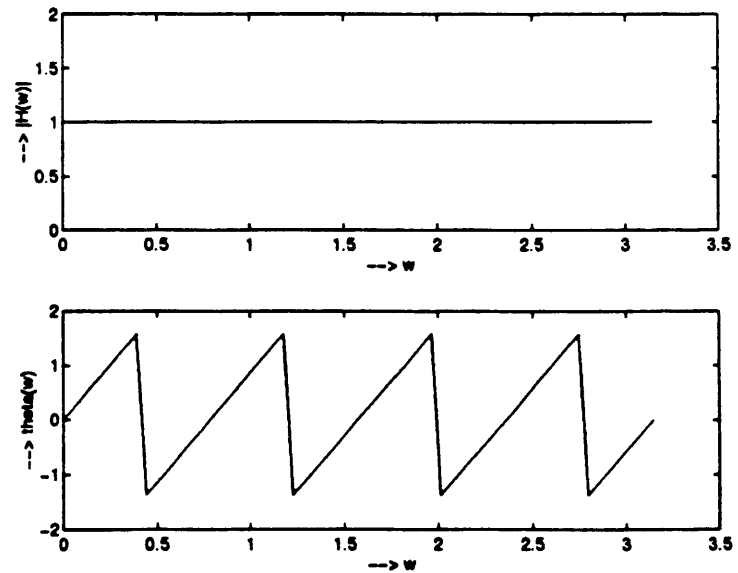

Figure 4.23:

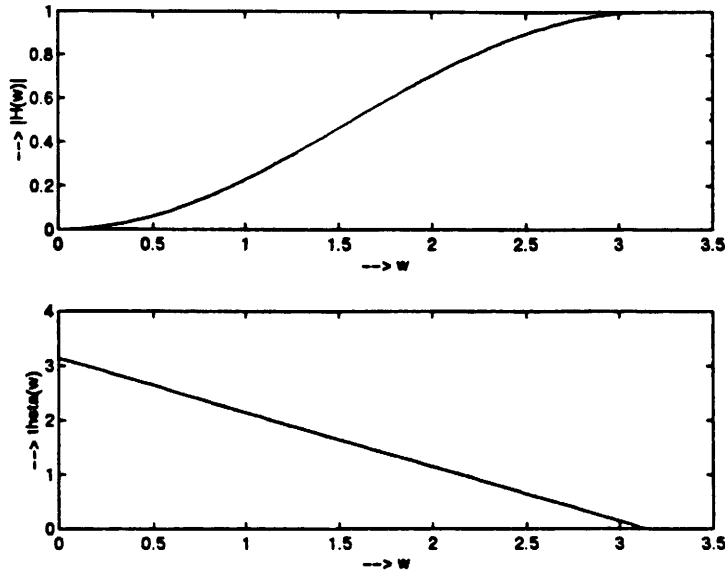

Figure 4.24:

Refer to fig 4.25.

(b)

$$\begin{aligned}
 H\left(\frac{\pi}{10}\right) &= 0 \\
 H\left(\frac{\pi}{3}\right) &= (2\cos\frac{5\pi}{3})e^{-j\frac{2\pi}{3}} \\
 y(n) &= (6\cos\frac{5\pi}{3})\sin\left(\frac{\pi}{3} + \frac{\pi}{10} - \frac{5\pi}{3}\right) \\
 &= (6\cos\frac{5\pi}{3})\sin\left(\frac{\pi}{3} - \frac{47\pi}{30}\right)
 \end{aligned}$$

(c)

$$\begin{aligned}
 H(0) &= 2 \\
 H\left(\frac{4\pi}{10}\right) &= 2 \\
 y(n) &= 20 + 10\cos\frac{2\pi n}{5} + \frac{\pi}{2}
 \end{aligned}$$

4.31

$$\begin{aligned}
 h(n) &= \delta(n) + 2\delta(n-2) + \delta(n-4) \\
 H(w) &= 1 + 2e^{-j2w} + e^{-j4w} \\
 &= (1 + e^{-j2w})^2 \\
 &= 4(\cos w)^2 e^{-j2w}
 \end{aligned}$$

Steady State Response: $H\left(\frac{\pi}{2}\right) = 0$

Therefore, $y_{ss}(n) = 0, (n \geq 4)$

Transient Response:

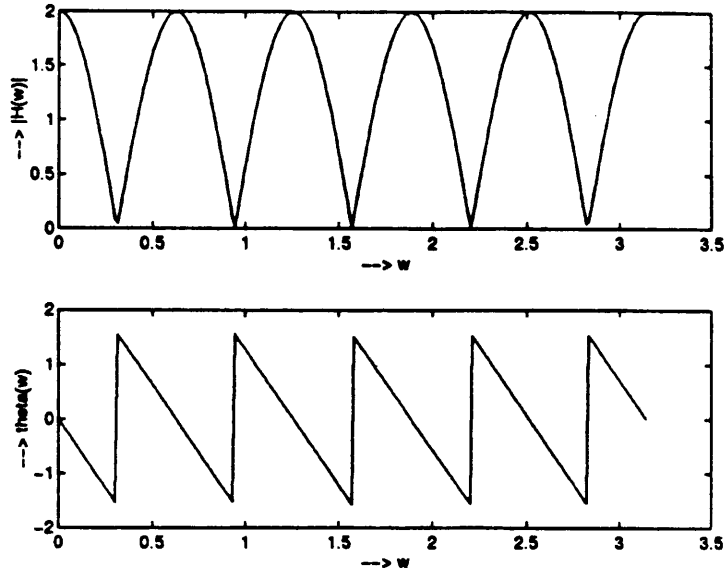

Figure 4.25:

$$\begin{aligned}
 y_{tr}(n) &= 10e^{\frac{\pi n}{2}} u(n) + 20e^{\frac{\pi(n-2)}{2}} u(n-2) + 10e^{\frac{\pi(n-4)}{2}} u(n-4) \\
 &= 10\delta(n) + j10\delta(n-1) + 10\delta(n-2) + j10\delta(n-3)
 \end{aligned}$$

4.32

(a)

$$\begin{aligned}
 y(n) &= x(n) + x(n-4) \\
 Y(w) &= (1 + e^{-j4w})X(w) \\
 H(w) &= (2\cos 2w)e^{-j2w}
 \end{aligned}$$

Refer to fig 4.26.

(b)

$$\begin{aligned}
 y(n) &= \cos\frac{\pi}{2}n + \cos\frac{\pi}{4}n + \cos\frac{\pi}{2}(n-4) + \cos\frac{\pi}{4}(n-4) \\
 \text{But } \cos\frac{\pi}{2}(n-4) &= \cos\frac{\pi}{2}n\cos 2\pi + \sin\frac{\pi}{2}n\sin 2\pi \\
 &= \cos\frac{\pi}{2}n \\
 \text{and } \cos\frac{\pi}{4}(n-4) &= \cos\frac{\pi}{4}n\cos\pi - \sin\frac{\pi}{4}n\sin\pi \\
 &= -\cos\frac{\pi}{4}n \\
 \text{Therefore, } y(n) &= 2\cos\frac{\pi}{2}n
 \end{aligned}$$

(c) Note that $H(\frac{\pi}{2}) = 2$ and $H(\frac{\pi}{4}) = 0$. Therefore, the filter does not pass the signal $\cos(\frac{\pi}{4}n)$.

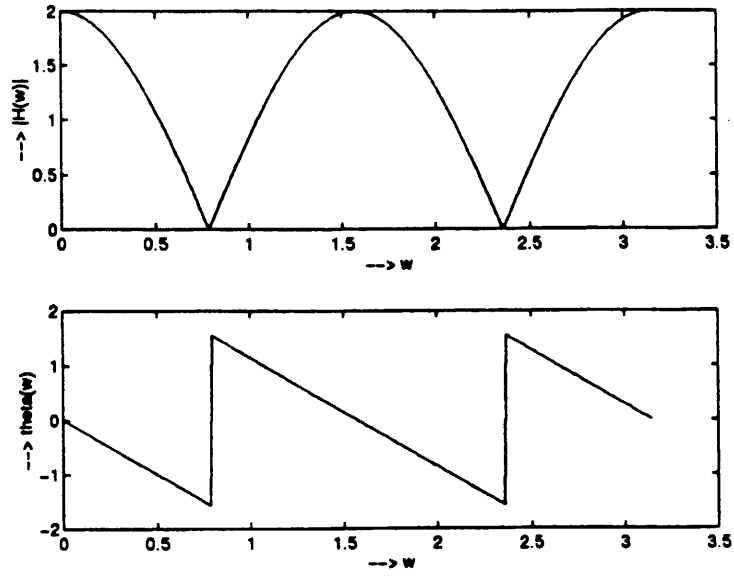

Figure 4.26:

4.33

$$\begin{aligned}
 y(n) &= \frac{1}{2}[x(n) - x(n-2)] \\
 Y(w) &= \frac{1}{2}(1 - e^{-j2w})X(w) \\
 H(w) &= \frac{1}{2}(1 - e^{-j2w}) \\
 &= (\sin w)e^{j(\frac{\pi}{2}-w)} \\
 H(0) &= 0, H(\frac{\pi}{2}) = 1 \\
 \text{Hence, } y_{ss}(n) &= 3\cos(\frac{\pi}{2}n + 60^\circ) \\
 y_{tr}(n) &= 0
 \end{aligned}$$

4.34

$$x(n) = A\cos\frac{\pi}{4}n$$

$$(a) y(n) = x(2n) = A\cos\frac{\pi}{2}n \Rightarrow w = \frac{\pi}{2}$$

$$(b) y(n) = x^2(n) = A^2\cos^2\frac{\pi}{4}n = \frac{1}{2}A^2 + \frac{1}{2}A^2\cos\frac{\pi}{2}n. \text{ Hence, } w = 0 \text{ and } w = \frac{\pi}{2}$$

(c)

$$\begin{aligned}
 y(n) &= x(n)\cos\pi n \\
 &= A\cos\frac{\pi}{4}n\cos\pi n \\
 &= \frac{A}{2}\cos\frac{5\pi}{4}n + \frac{A}{2}\cos\frac{3\pi}{4}n \\
 \text{Hence, } w &= \frac{3\pi}{4} \text{ and } w = \frac{5\pi}{4}
 \end{aligned}$$

4.35

(a)

$$\begin{aligned}
 y(n) &= \frac{1}{2} [x(n) + x(n-1)] \\
 Y(w) &= \frac{1}{2} (1 + e^{-jw}) X(w) \\
 H(w) &= \frac{1}{2} (1 + e^{-jw}) \\
 &= \cos\left(\frac{w}{2}\right) e^{-j\frac{w}{2}}
 \end{aligned}$$

Refer to fig 4.27.

(b)

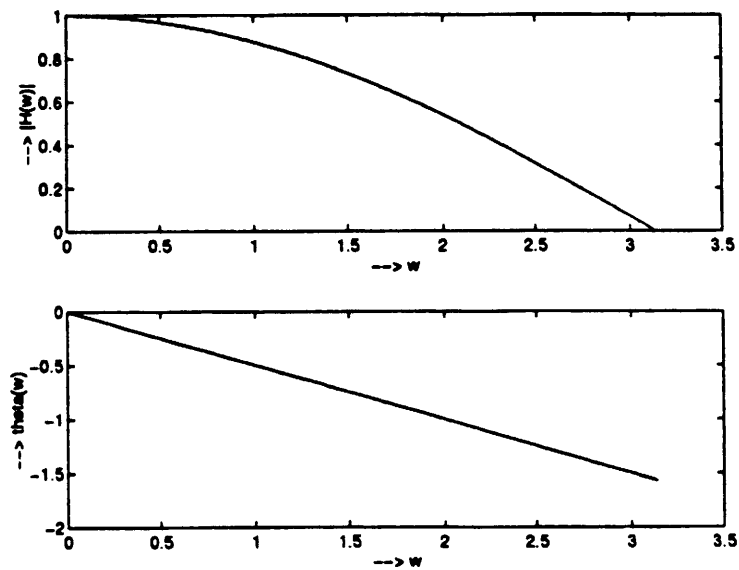

Figure 4.27:

$$\begin{aligned}
 y(n) &= -\frac{1}{2} [x(n) - x(n-1)] \\
 Y(w) &= -\frac{1}{2} (1 - e^{-jw}) X(w) \\
 |H(w)| &= \sin\frac{w}{2} \\
 \Theta(w) &= e^{j(\frac{w}{2} - \frac{\pi}{2})}
 \end{aligned}$$

Refer to fig 4.28.

(c)

$$\begin{aligned}
 y(n) &= \frac{1}{8} [x(n) + 3x(n-1) + 3x(n-2) + x(n-3)] \\
 Y(w) &= \frac{1}{8} (1 + e^{-jw})^3 X(w) \\
 H(w) &= \frac{1}{8} (1 + e^{-jw})^3 \\
 &= \cos^3\left(\frac{w}{2}\right) e^{-j\frac{3w}{2}}
 \end{aligned}$$

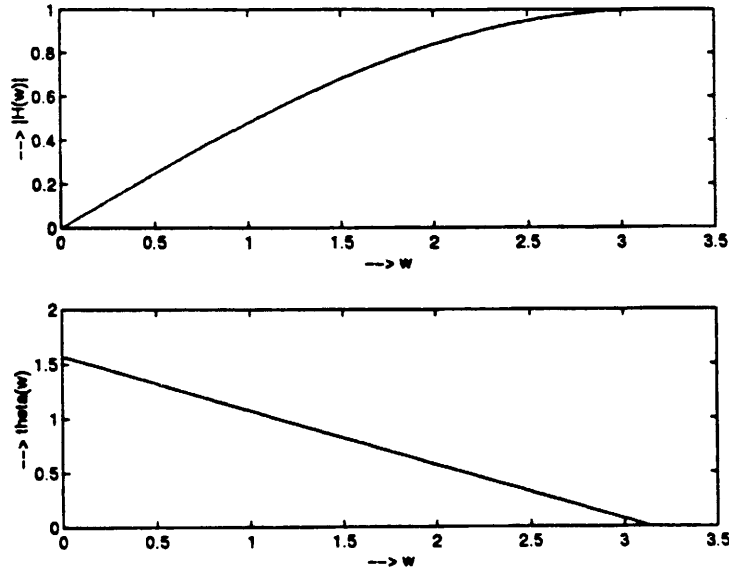

Figure 4.28:

Refer to fig 4.29.

4.36

$$\begin{aligned}
 y(n) &= x(n) + x(n - M) \\
 Y(w) &= (1 + e^{-jwM})X(w) \\
 H(w) &= (1 + e^{-jwM}) \\
 H(w) &= 0, \text{ at } \frac{wM}{2} = (k + \frac{1}{2})\pi, \quad k = 0, 1, \dots \\
 \text{or } w &= (2k + 1)\pi/M, \quad k = 0, 1, \dots \\
 |H(w)| &= |2\cos\frac{wM}{2}|
 \end{aligned}$$

4.37

$$y(n) = 0.9y(n - 1) + bx(n)$$

(a)

$$\begin{aligned}
 Y(w) &= 0.9e^{-jw}Y(w) + bX(w) \\
 H(w) &= \frac{Y(w)}{X(w)} \\
 &= \frac{b}{1 - 0.9e^{-jw}} \\
 |H(0)| &= 1, \Rightarrow b = \pm 0.1 \\
 \Theta(w) &= \begin{cases} -\frac{wM}{2}, & \cos\frac{wM}{2} > 0 \\ \pi - \frac{wM}{2}, & \cos\frac{wM}{2} < 0 \end{cases}
 \end{aligned}$$

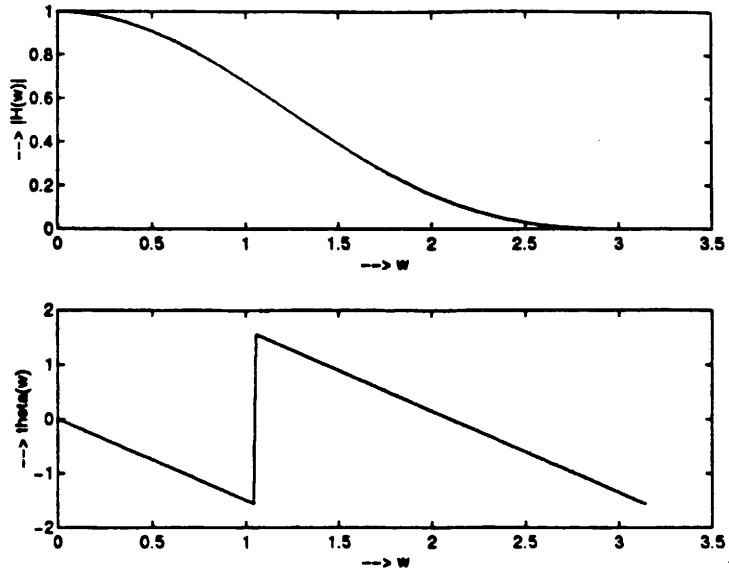

Figure 4.29:

- (b) $|H(\omega_0)|^2 = \frac{1}{2} \Rightarrow \frac{b^2}{1.81 - 1.8 \cos \omega_0} = \frac{1}{2} \Rightarrow \omega_0 = 0.105$
(c) The filter is lowpass.
(d) For $|H(\omega_0)|^2 = \frac{1}{2} \Rightarrow \omega_0 = 3.036$. This filter is a highpass filter.

4.38

(a)

$$\begin{aligned}
 P_x &= \frac{1}{N} \sum_{n=0}^{N-1} |x(n)|^2 \\
 &= \sum_{k=0}^{N-1} |c_k|^2 \\
 &= c_0^2 + 2 \sum_{k=1}^{\frac{N}{2}-1} |c_k|^2
 \end{aligned}$$

$$\text{Spurious power} = P_x - 2|c_{k0}|^2$$

$$\begin{aligned}
 \text{THD} &= \frac{P_x - 2|c_{k0}|^2}{P_x} \\
 &= 1 - \frac{2|c_{k0}|^2}{P_x}
 \end{aligned}$$

- (b) for $f_0 = \frac{1}{96}$, refer to fig 4.30
for $f_0 = \frac{1}{32}$, refer to fig 4.31
for $f_0 = \frac{1}{256}$, refer to fig 4.32
(c) for $f_0 = \frac{1}{96}$, refer to fig 4.33
for $f_0 = \frac{1}{32}$, refer to fig 4.34
for $f_0 = \frac{1}{256}$, refer to fig 4.35

The total harmonic distortion (THD) reduces as the number of terms in the Taylor approximation is increased.

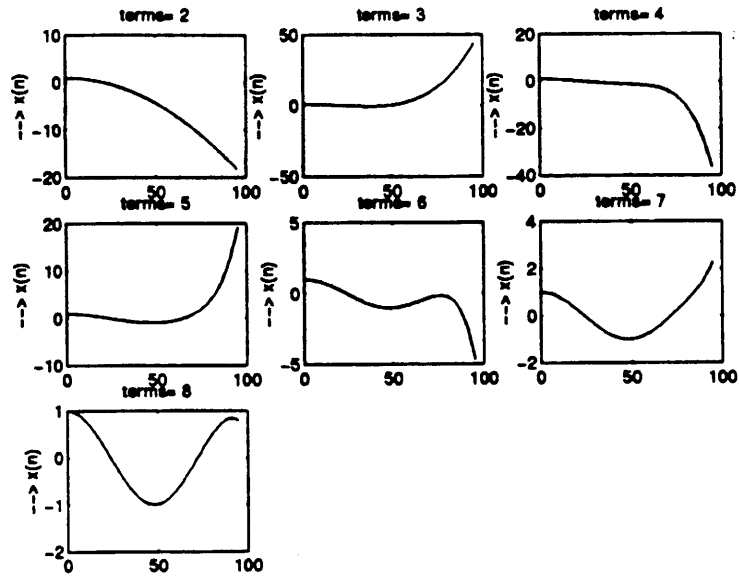

Figure 4.30:

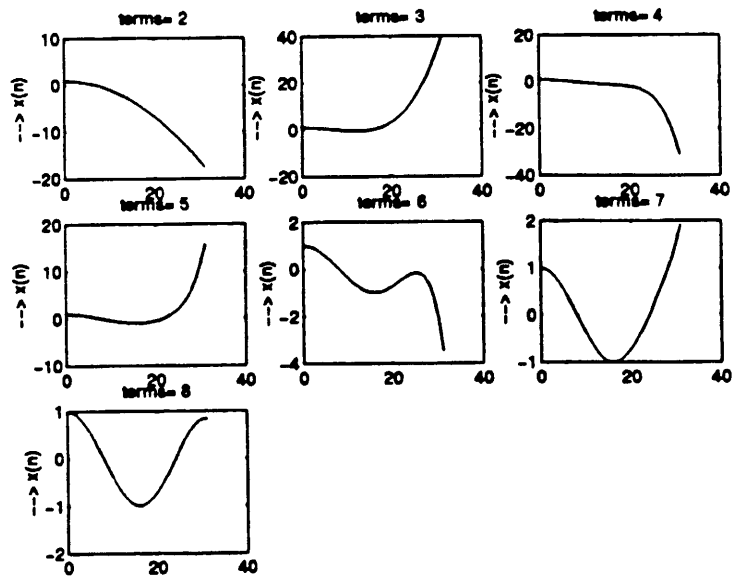

Figure 4.31:

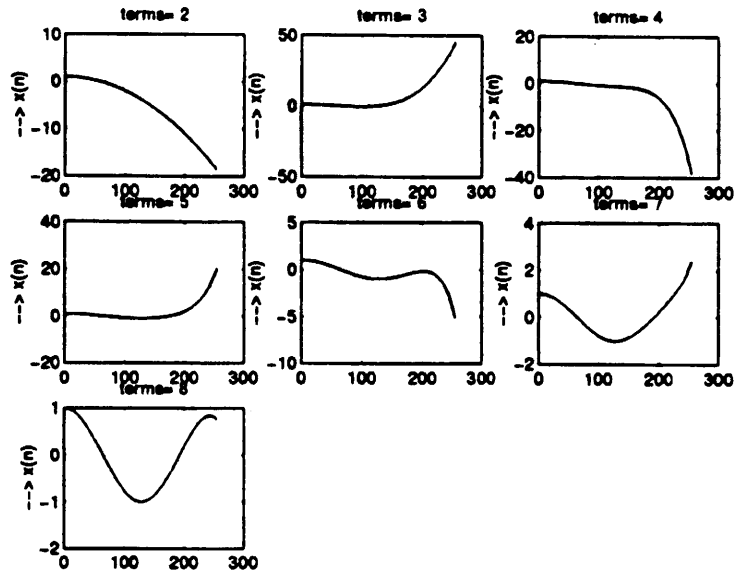

Figure 4.32:

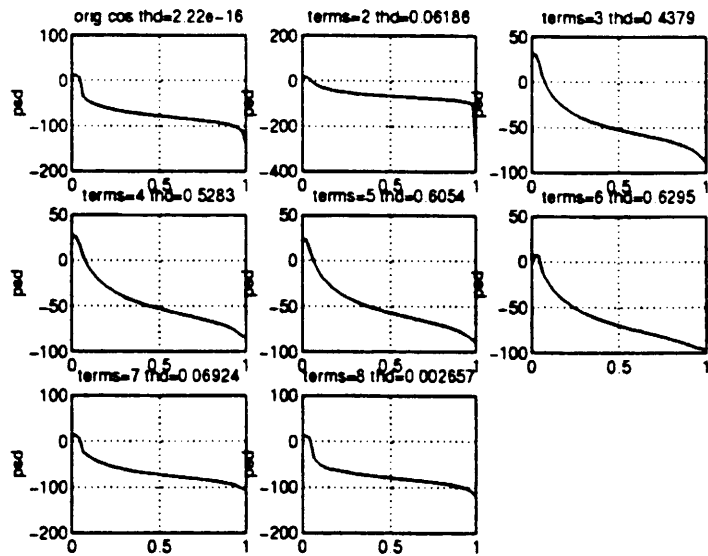

Figure 4.33:

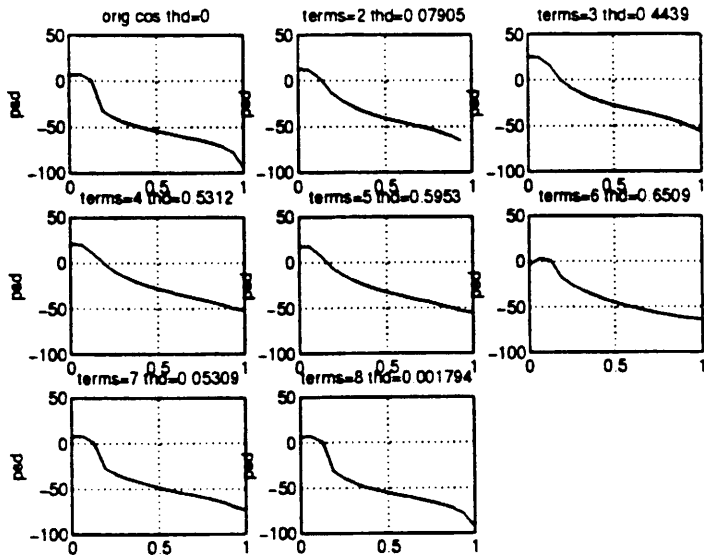

Figure 4.34:

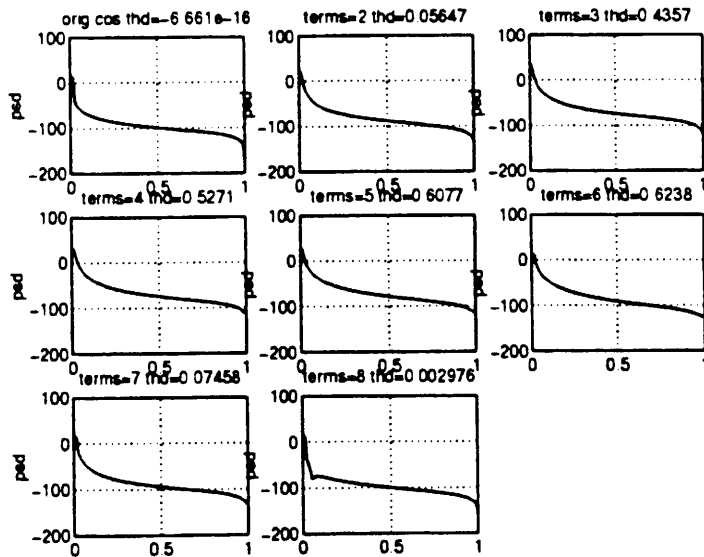

Figure 4.35:

4.39

(a) Refer to fig 4.36

(b) $f_0 = \frac{1}{50}$

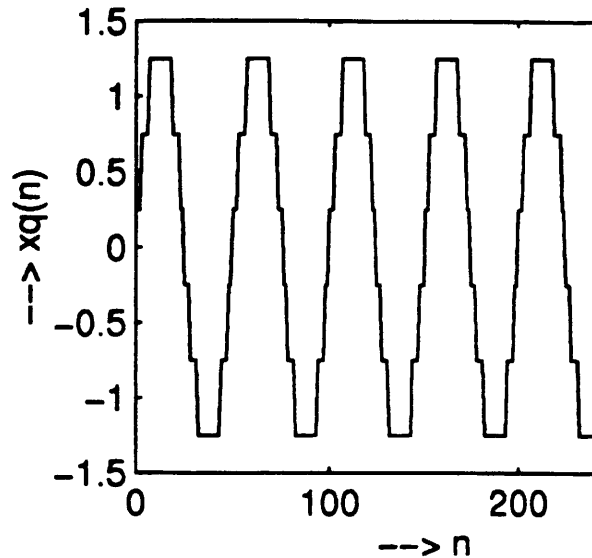
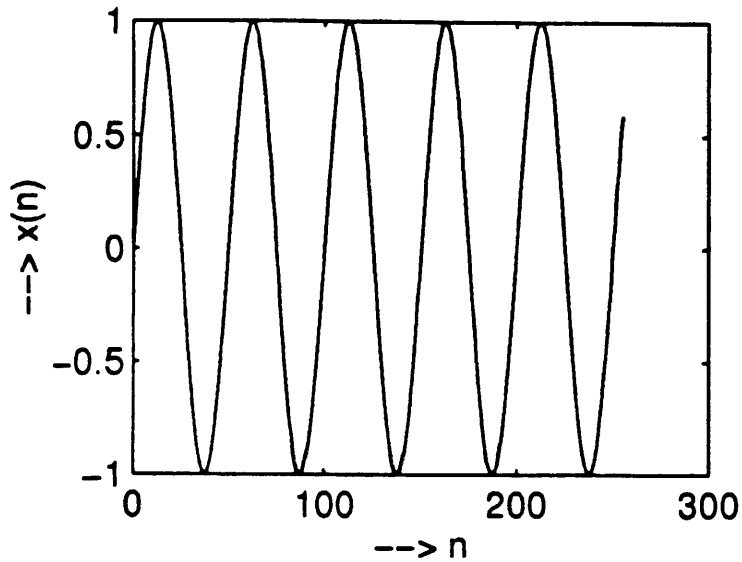

Figure 4.36:

bits	4	6	8	16
THD	$9.4616e-04$	$5.3431e-05$	$3.5650e-06$	$4.2848e-11$

(c) $f_0 = \frac{1}{100}$

bits	4	6	8	16
THD	$9.1993e-04$	$5.5965e-05$	$3.0308e-06$	$4.5383e-11$

(d) As the number of bits are increased, THD is reduced considerably.

4.40

(a) Refer to fig 4.37

(b) Refer to fig 4.38

The response of the system to $x_i(n)$ can be seen from fig 4.39

4.41

(a)

$$\begin{aligned}
 H(\omega) &= \sum_{n=-\infty}^{\infty} h(n)e^{-j\omega n} \\
 &= \sum_{n=-\infty}^{-1} \left(\frac{1}{3}\right)^{-n} e^{-j\omega n} + \sum_{n=0}^{\infty} \left(\frac{1}{3}\right)^n e^{-j\omega n}
 \end{aligned}$$

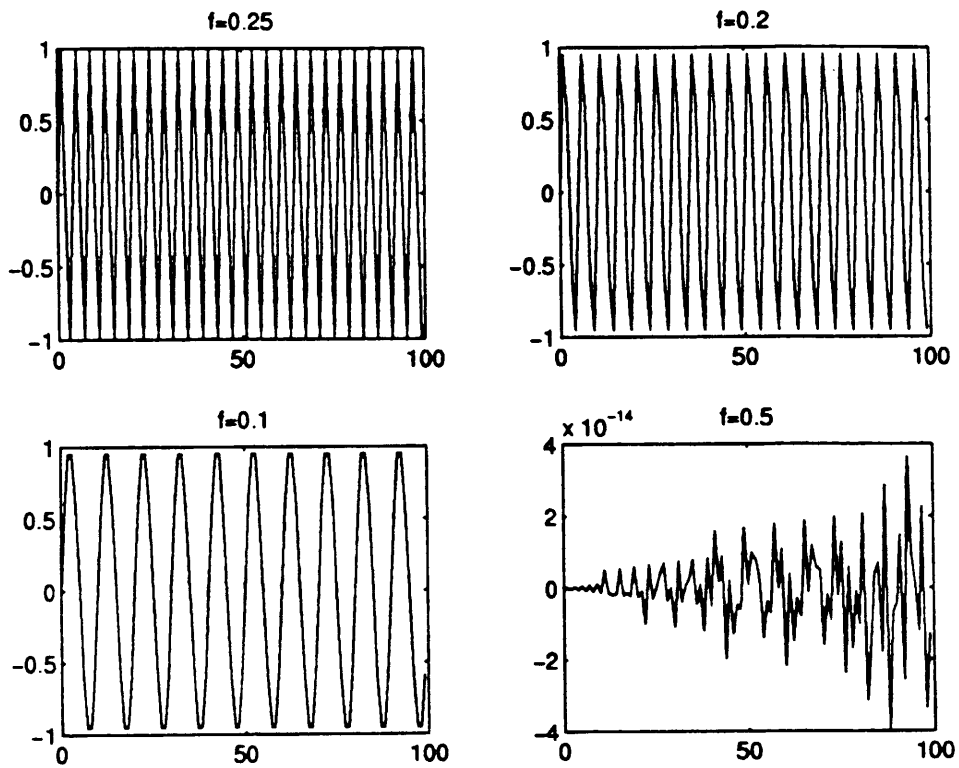

Figure 4.37:

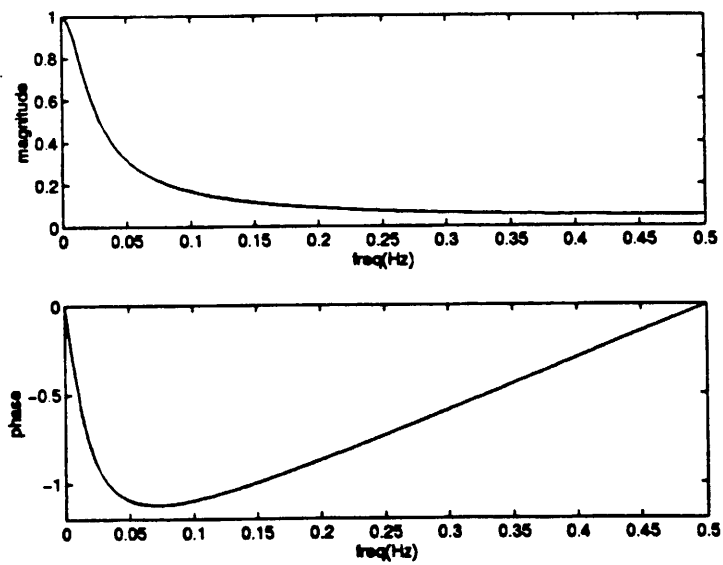

Figure 4.38:

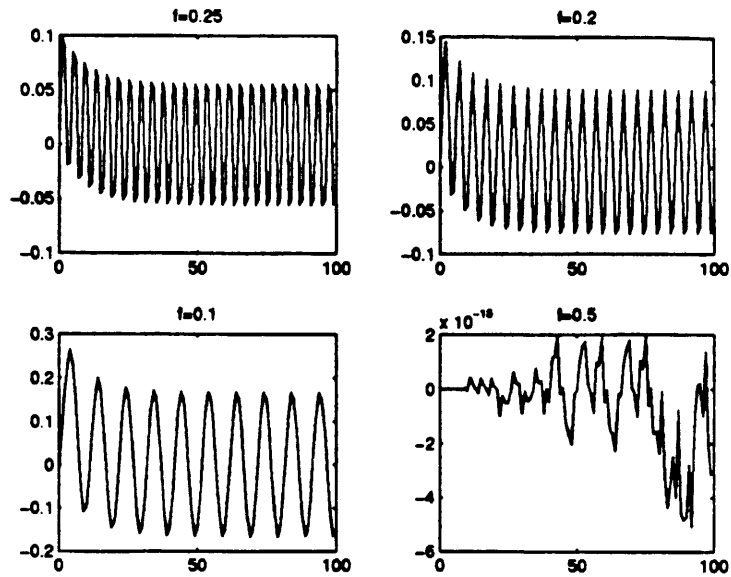

Figure 4.39:

$$\begin{aligned}
 &= \frac{\frac{1}{2}e^{j\omega}}{1 - \frac{1}{3}e^{j\omega}} + \frac{1}{1 - \frac{1}{3}e^{j\omega}} \\
 &= \frac{4}{5 - 3\cos\omega} \\
 |H(\omega)| &= \frac{4}{5 - 3\cos\omega} \\
 \angle H(\omega) &= 0
 \end{aligned}$$

(b) (1)

$$\begin{aligned}
 x(n) &= \cos\frac{3\pi n}{8} \\
 X(\omega) &= \pi \left[\delta\left(\omega - \frac{3\pi}{8}\right) + \delta\left(\omega + \frac{3\pi}{8}\right) \right], -\pi \leq \omega \leq \pi \\
 Y(\omega) &= H(\omega)X(\omega) \\
 &= \frac{4\pi}{5 - 3\cos\frac{3\pi}{8}} \left[\delta\left(\omega - \frac{3\pi}{8}\right) + \delta\left(\omega + \frac{3\pi}{8}\right) \right]
 \end{aligned}$$

Hence, the output is simply $y(n) = A \cos\frac{3\pi n}{8}$

where $A = H(\omega)|_{\omega=\frac{3\pi}{8}} = H\left(\frac{3\pi}{8}\right)$

(2)

$$\begin{aligned}
 x(n) &= \left\{ \dots, -1, 1, -1, 1, -1, 1, -1, 1, -1, \dots \right\} \\
 &= \cos\pi n, -\infty < n < \infty \\
 H(\omega)|_{\omega=\pi} &= \frac{4}{5 - 3\cos\pi} = \frac{4}{8} = \frac{1}{2} \\
 y(n) &= \frac{1}{2} \cos\pi n
 \end{aligned}$$

$$Y(\omega) = \frac{\pi}{2} [\delta(\omega - \pi) + \delta(\omega + \pi)]$$

4.42

(a)

$$\begin{aligned} x_a(t) &= e^{-j2\pi F_0 t} \\ X_a(F) &= \int_0^{\infty} x_a(t) e^{-j2\pi F t} dt \\ &= \int_0^{\infty} e^{-j2\pi F_0 t} e^{-j2\pi F t} dt \\ &= \int_0^{\infty} e^{-j2\pi(F+F_0)t} dt \\ &= \frac{e^{-j2\pi(F+F_0)t}}{-j2\pi(F+F_0)} \Big|_0^{\infty} \\ X_a(F) &= \frac{1}{j2\pi(F+F_0)} \end{aligned}$$

(b)

$$\begin{aligned} x(n) &= e^{-\frac{j2\pi F_0 n}{F_s}} \\ X(f) &= \sum_{n=-\infty}^{\infty} x(n) e^{-j2\pi f n} \\ &= \sum_{n=0}^{\infty} e^{-\frac{j2\pi F_0 n}{F_s}} e^{-j2\pi f n} \\ &= \sum_{n=0}^{\infty} e^{-j2\pi(F + \frac{F_0}{F_s})n} \\ &= \frac{1}{1 - e^{-j2\pi(F + \frac{F_0}{F_s})}} \end{aligned}$$

(c) Refer to fig 4.40

(d) Refer to fig 4.41

(e) Aliasing occurs at $F_s = 10\text{Hz}$.

4.43

(a)

$$\begin{aligned} y(n) &= x(n) - 2\cos\omega_0 x(n-1) + x(n-2) \\ h(n) &= \delta(n) - 2\cos\omega_0 \delta(n-1) + \delta(n-2) \end{aligned}$$

(b)

$$\begin{aligned} H(\omega) &= 1 - 2\cos\omega_0 e^{-j\omega} + e^{-j2\omega} \\ &= (1 - e^{-j\omega_0} e^{-j\omega})(1 - e^{j\omega_0} e^{j\omega}) \\ &= -4e^{-j\omega} \sin \frac{\omega + \omega_0}{2} \sin \frac{\omega - \omega_0}{2} \\ &= -2e^{-j\omega} (\cos\omega - \cos\omega_0) \\ |H(\omega)| &= 2|\cos\omega - \cos\omega_0| \\ \Rightarrow |H(\omega)| &= 0 \text{ at } \omega = \pm\omega_0 \end{aligned}$$

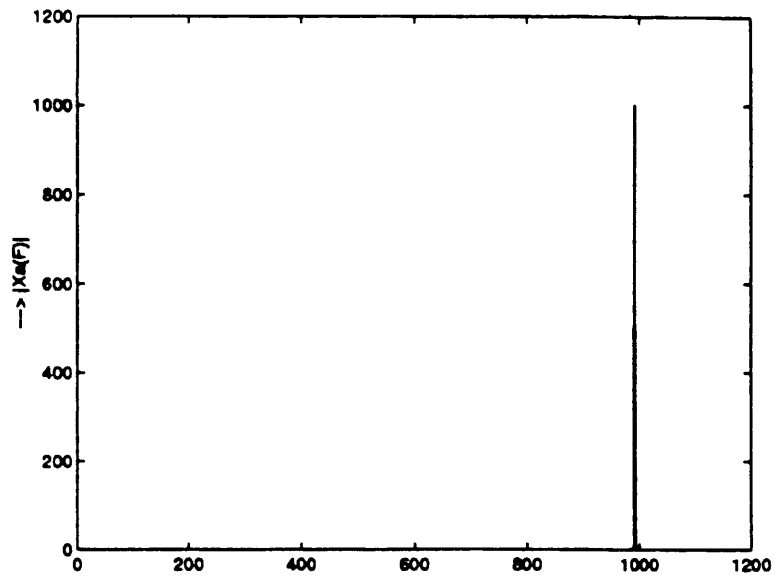

Figure 4.40:

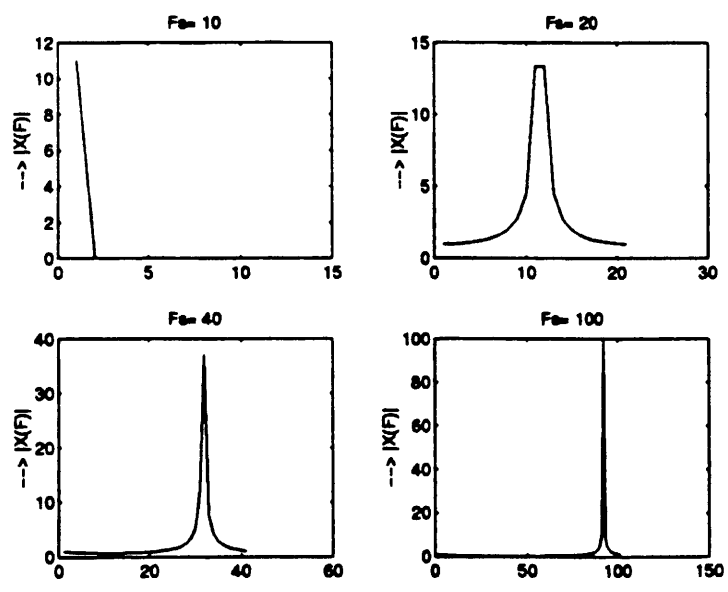

Figure 4.41:

Refer to fig 4.42.

(c)

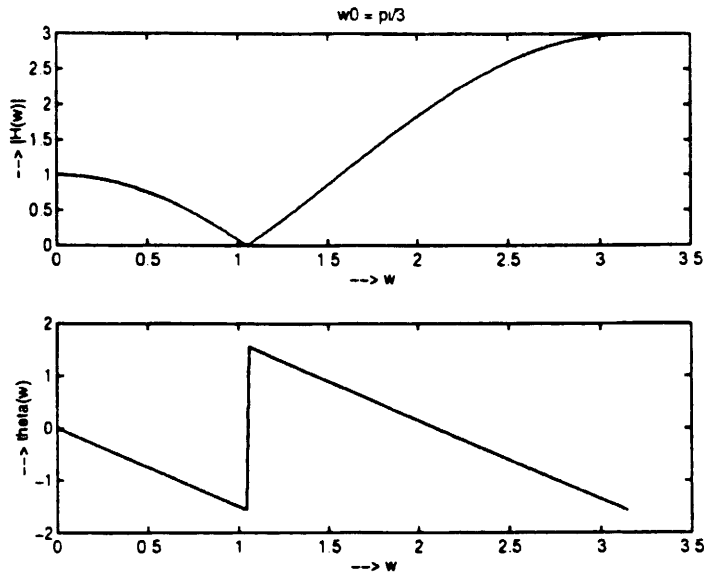

Figure 4.42:

$$\begin{aligned} \text{when } w_0 = \pi/2, H(w) &= 1 - e^{j2w} \\ \text{at } w = \pi/3, H(\pi/3) &= 1 - e^{j2\pi/3} = 1e^{j\pi/3} \\ y(n) &= |H(\pi/3)|3\cos\left(\frac{\pi}{3}n + 30^\circ - 60^\circ\right) \\ &= 3\cos\left(\frac{\pi}{3}n - 30^\circ\right) \end{aligned}$$

4.44

(a)

$$\begin{aligned} y(n) &= x(n) - x(n-4) \\ H(w) &= 1 - e^{-j4w} \\ &= 2e^{-j2w}e^{j\pi/2}\sin 2w \end{aligned}$$

Refer to fig 4.43.

(b)

$$\begin{aligned} x(n) &= \cos\frac{\pi}{2}n + \cos\frac{\pi}{4}n, \quad H\left(\frac{\pi}{2}\right) = 0 \\ y(n) &= 2\cos\frac{\pi}{4}n, \quad H\left(\frac{\pi}{4}\right) = 2, \quad \angle H\left(\frac{\pi}{4}\right) = 0 \end{aligned}$$

(c) The filter blocks the frequency at $w = \frac{\pi}{2}$.

4.45

$$y(n) = \frac{1}{2}[x(n) - x(n-2)]$$

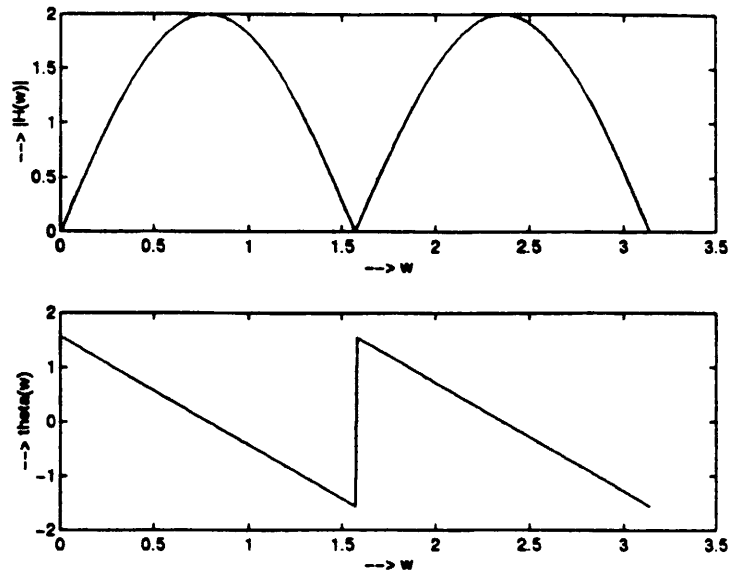

Figure 4.43:

$$\begin{aligned}
 H(w) &= \frac{1}{2}(1 - e^{-j2w}) \\
 &= e^{-jw} e^{j\pi/2} \sin w \\
 x(n) &= 5 + 3\sin\left(\frac{\pi}{2}n + 60^\circ\right) + 4\sin(\pi n + 45^\circ) \\
 H(0) &= 0, \quad H\left(\frac{\pi}{2}\right) = 1, \quad H(\pi) = 0 \\
 y(n) &= 3\sin\left(\frac{\pi}{2}n + 60^\circ\right)
 \end{aligned}$$

4.46

(a)

$y(n) = x(2n) \Rightarrow$ This is a linear, time-varying system

$$\begin{aligned}
 Y(w) &= \sum_{n=-\infty}^{\infty} y(n)e^{-jwn} \\
 &= \sum_{n=-\infty}^{\infty} x(2n)e^{-jwn} \\
 &= X\left(\frac{w}{2}\right) \\
 &= 1, \quad |w| \leq \frac{\pi}{2} \\
 &= 0, \quad \frac{\pi}{2} \leq |w| \leq \pi
 \end{aligned}$$

(b)

$y(n) = x^2(n) \Rightarrow$ This is a non-linear, time-invariant system

$$Y(w) = \frac{1}{2\pi} X(w) * X(w)$$

Refer to fig 4.44.

(c)

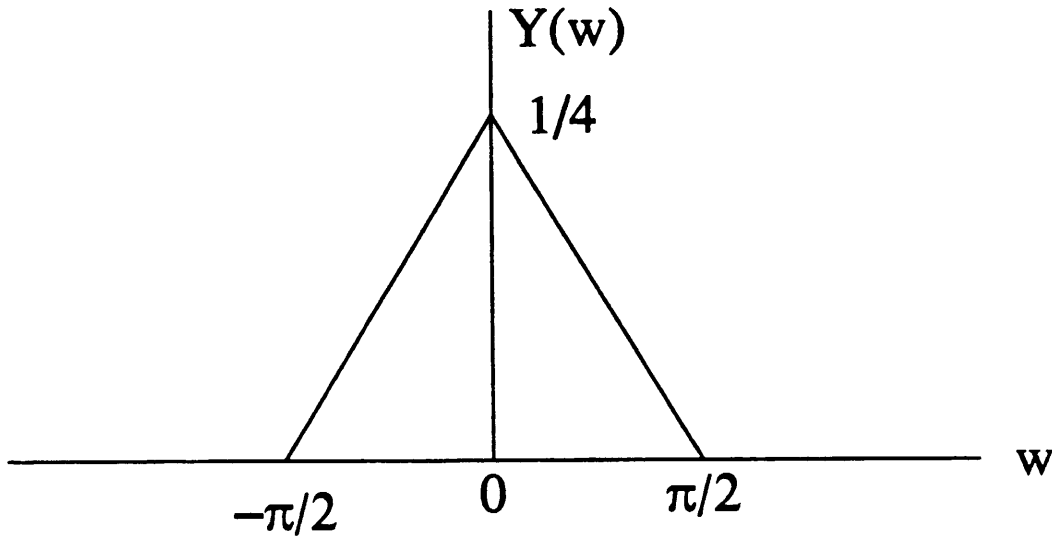

Figure 4.44:

$$y(n) = (\cos \pi n)x(n) \Rightarrow \text{This is a time-varying system}$$

$$\begin{aligned} Y(w) &= \frac{1}{2\pi} [\pi\delta(w - \pi) + \pi\delta(w + \pi)] * X(w) \\ &= \frac{1}{2} [X(w - \pi) + X(w + \pi)] \\ &= 0, \quad |w| \leq \frac{3\pi}{4} \\ &= \frac{1}{2}, \quad \frac{3\pi}{4} \leq |w| \leq \pi \end{aligned}$$

4.47

$$h(n) = \left[\left(\frac{1}{4}\right)^n \cos \frac{\pi}{4} n u(n) \right]$$

(a)

$$\begin{aligned} H(z) &= \frac{1 - \frac{1}{4} \cos \frac{\pi}{4} z^{-1}}{1 - 2\left(\frac{1}{4}\right) \cos \frac{\pi}{4} z^{-1} + \left(\frac{1}{4}\right)^2 z^{-2}} \\ &= \frac{1 - \frac{\sqrt{2}}{8} z^{-1}}{1 - \frac{\sqrt{2}}{4} z^{-1} + \frac{1}{16} z^{-2}} \end{aligned}$$

(b) Yes. Refer to fig 4.45

(c) Poles at $z = \frac{1}{4}e^{\pm j\frac{\pi}{4}}$, zeros at $z = \frac{\sqrt{2}}{8}$.

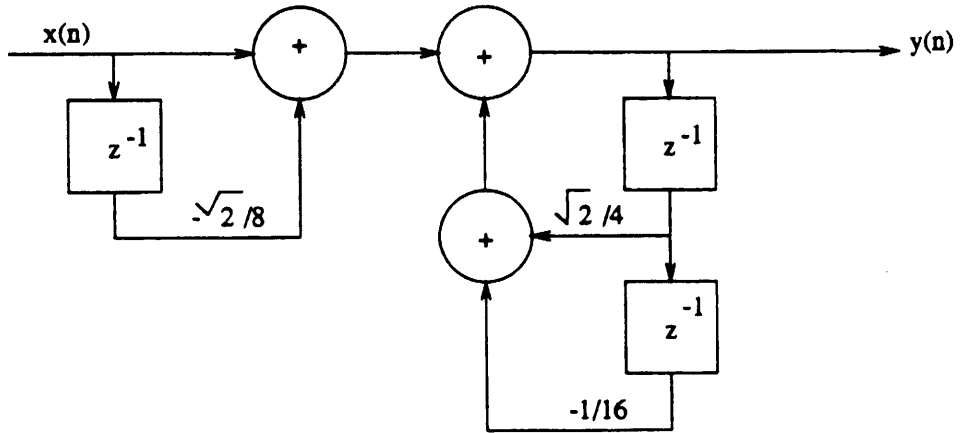

Figure 4.45:

$$H(\omega) = \frac{1 - \frac{\sqrt{2}}{8}e^{-j\omega}}{1 - \frac{\sqrt{2}}{4}e^{-j\omega} + \frac{1}{16}e^{-j2\omega}}. \text{ Refer to fig 4.46.}$$

(d)

$$x(n) = \left(\frac{1}{4}\right)^n u(n)$$

$$X(z) = \frac{1}{1 - \frac{1}{4}z^{-1}}$$

$$Y(z) = X(z)H(z)$$

$$= \frac{\frac{1}{2}}{1 - \frac{1}{4}z^{-1}} + \frac{\frac{1}{2}(1 - \frac{\sqrt{2}}{8}z^{-1})}{1 - \frac{\sqrt{2}}{4}z^{-1} + \frac{1}{16}z^{-2}}$$

$$+ \frac{\frac{1+\sqrt{2}}{2} \frac{\sqrt{2}}{8} z^{-1}}{1 - \frac{\sqrt{2}}{4}z^{-1} + \frac{1}{16}z^{-2}}$$

$$y(n) = \frac{1}{2} \left(\frac{1}{4}\right)^n \left[1 + \cos \frac{\pi}{4}n + (1 + \sqrt{2}) \sin \frac{\pi}{4}n \right] u(n)$$

4.48

$$y(n) = x(n) - x(n-10)$$

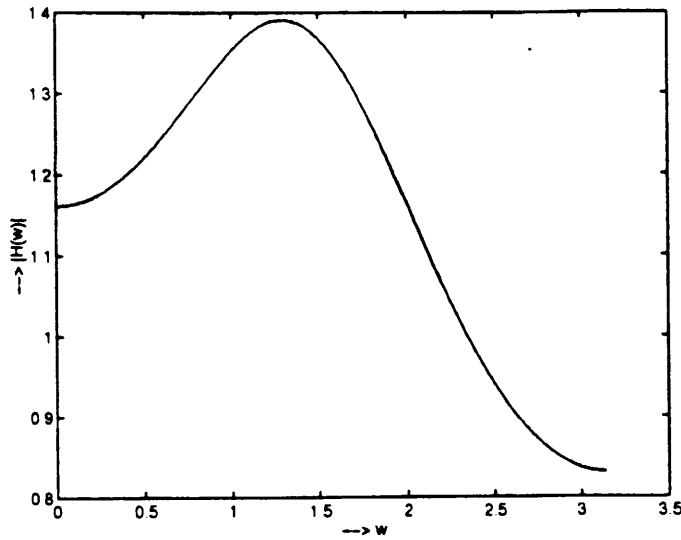

Figure 4.46:

(a)

$$\begin{aligned}
 H(w) &= 1 - e^{-j10w} \\
 &= 2e^{-j5w} e^{j\frac{\pi}{2}} \sin 5w \\
 |H(w)| &= 2|\sin 5w|, \\
 \Theta(w) &= \frac{\pi}{2} - 5w, \text{ for } \sin 5w > 0 \\
 &= \frac{\pi}{2} - 5w + \pi, \text{ for } \sin 5w < 0
 \end{aligned}$$

Refer to fig 4.47.

(b)

$$\begin{aligned}
 |H(\frac{\pi}{10})| &= 2, \quad \angle H(\frac{\pi}{10}) = 0 \\
 |H(\frac{\pi}{3})| &= \sqrt{3}, \quad \Theta(\frac{\pi}{3}) = \angle H(\frac{\pi}{3}) = -\frac{\pi}{6} \\
 (1) \text{ Hence, } y(n) &= 2\cos\frac{\pi}{10}n + 3\sqrt{3}\sin(\frac{\pi}{3}n - \frac{\pi}{15}) \\
 H(0) &= 0, \quad H(\frac{2\pi}{5}) = 0 \\
 (2) \text{ Hence, } y(n) &= 0
 \end{aligned}$$

4.49

(a)

$$\begin{aligned}
 h(n) &= \frac{1}{2\pi} \int_{-\pi}^{\pi} X(w) e^{jwn} dw \\
 &= \frac{1}{2\pi} \left[\int_{-\frac{3\pi}{4}}^{\frac{3\pi}{4}} e^{jwn} dw - \int_{-\frac{\pi}{4}}^{\frac{\pi}{4}} e^{-jwn} dw \right]
 \end{aligned}$$

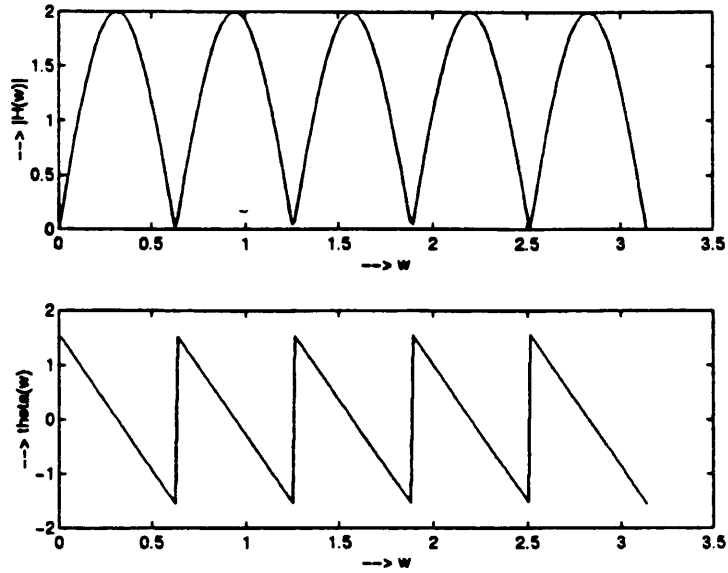

Figure 4.47:

$$\begin{aligned}
 &= \frac{1}{\pi n} \left[\sin \frac{3\pi}{8} n - \sin \frac{\pi}{8} n \right] \\
 &= \frac{2}{\pi n} \sin \frac{\pi}{8} n \cos \frac{\pi}{4} n
 \end{aligned}$$

(b) Let

$$h_1(n) = \frac{2 \sin \frac{\pi}{8} n}{n\pi}$$

Then,

$$H_1(w) = \begin{cases} 2, & |w| \leq \frac{\pi}{8} \\ 0, & \frac{\pi}{8} < |w| < \pi \end{cases}$$

and

$$h(n) = h_1(n) \cos \frac{\pi}{4} n$$

4.50

$$\begin{aligned}
 y(n) &= \frac{1}{2} y(n-1) + x(n) + \frac{1}{2} x(n-1) \\
 Y(z) &= \frac{1}{2} z^{-1} Y(z) + X(z) + \frac{1}{2} z^{-1} X(z) \\
 H(z) &= \frac{Y(z)}{X(z)} \\
 &= \frac{1 + \frac{1}{2} z^{-1}}{1 - \frac{1}{2} z^{-1}}
 \end{aligned}$$

(a)

$$\begin{aligned}
 H(z) &= \frac{2}{1 - \frac{1}{2} z^{-1}} - 1 \\
 h(n) &= 2 \left(\frac{1}{2} \right)^n u(n) - \delta(n)
 \end{aligned}$$

(b)

$$\begin{aligned} H(\omega) &= \sum_{n=0}^{\infty} h(n)e^{-j\omega n} \\ &= \frac{2}{1 - \frac{1}{2}e^{-j\omega}} - 1 \\ &= \frac{1 + \frac{1}{2}e^{-j\omega}}{1 - \frac{1}{2}e^{-j\omega}} \\ &= H(z)|_{z=e^{j\omega}} \end{aligned}$$

(c)

$$\begin{aligned} H\left(\frac{\pi}{2}\right) &= \frac{1 + \frac{1}{2}e^{-j\frac{\pi}{2}}}{1 - \frac{1}{2}e^{-j\frac{\pi}{2}}} \\ &= \frac{1 - j\frac{1}{2}}{1 + j\frac{1}{2}} \\ &= 1e^{-j2\tan^{-1}\frac{1}{2}} \end{aligned}$$

Hence, $y(n) = \cos\left(\frac{\pi}{2}n + \frac{\pi}{4} - 2\tan^{-1}\frac{1}{2}\right)$

4.51

Refer to fig 4.48.

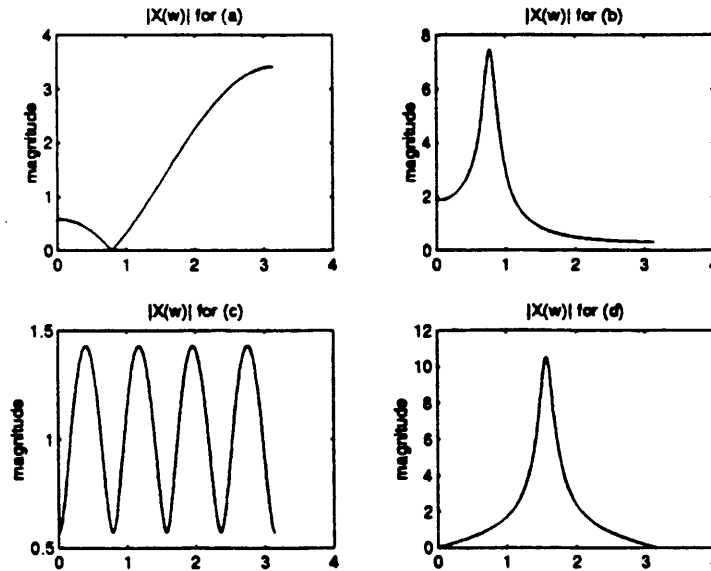

Figure 4.48:

4.52

$$H(z) = (1 - e^{j\frac{\pi}{4}}z^{-1})(1 - e^{-j\frac{\pi}{4}}z^{-1})$$

$$\begin{aligned}
&= 1 - \sqrt{2}z^{-1} + z^{-2} \\
H(w) &= 1 - \sqrt{2}e^{-jw} + e^{-2jw} \\
&= 2e^{-jw} \left(\cos w - \frac{\sqrt{2}}{2} \right) \\
y(n) &= x(n) - \sqrt{2}x(n-1) + x(n-2) \\
\text{for } x(n) &= \sin \frac{\pi}{4} u(n) \\
y(0) &= x(0) = 0 \\
y(1) &= x(1) - \sqrt{2}x(0) + x(-1) = \frac{\sqrt{2}}{2} \\
y(2) &= x(2) - \sqrt{2}x(1) + x(0) = 1 - \sqrt{2} \frac{\sqrt{2}}{2} + 0 = 0 \\
y(3) &= x(3) - \sqrt{2}x(2) + x(1) = \frac{\sqrt{2}}{2} - \sqrt{2} + \frac{\sqrt{2}}{2} = 0 \\
y(4) &= 0
\end{aligned}$$

4.53

- (a) $H(z) = k \frac{1-z^{-1}}{1+0.9z^{-1}}$. Refer to fig 4.49.
(b)

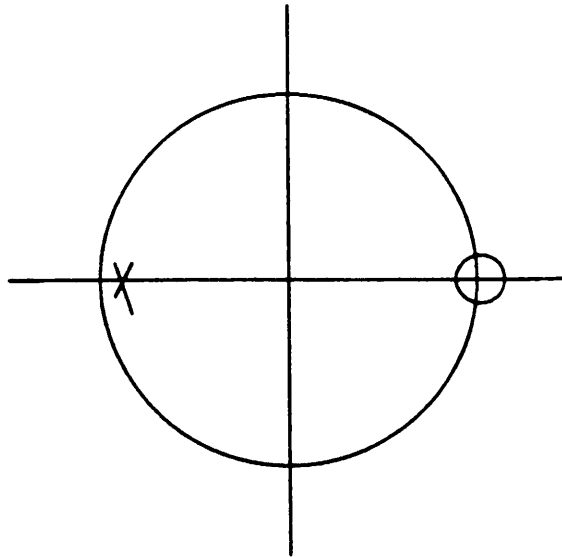

Figure 4.49:

$$H(w) = k \frac{1 - e^{-jw}}{1 + 0.9e^{-jw}}$$

$$|H(w)| = k \frac{2|\sin \frac{w}{2}|}{\sqrt{1.81 + 1.8 \cos w}}$$

$$\Theta(w) = \tan^{-1} \frac{\sin w}{1 - \cos w} + \tan^{-1} \frac{0.9 \sin w}{1 + 0.9 \cos w}$$

(c) $H(\pi) = k \frac{1 - e^{-j\pi}}{1 + 0.9e^{-j\pi}} = k \frac{2}{0.1} = 20k = 1 \Rightarrow k = \frac{1}{20}$

(d) $y(n] = -0.9y(n-1) + \frac{1}{20} [x(n) - x(n-1)]$

(e)

$$H\left(\frac{\pi}{6}\right) = 0.014e^{j\Theta\left(\frac{\pi}{6}\right)}$$

$$y(n) = 0.028 \cos\left(\frac{\pi}{6}n + 134.2^\circ\right)$$

4.54

(a) $H(z) = b_0 \frac{1 + bz^{-1}}{1 + az^{-1}}$. Refer to fig 4.50.

(b) For $a = 0.5, b = -0.6$, $H(z) = b_0 \frac{1 - 0.6z^{-1}}{1 + 0.5z^{-1}}$. Since the pole is inside the unit circle and the

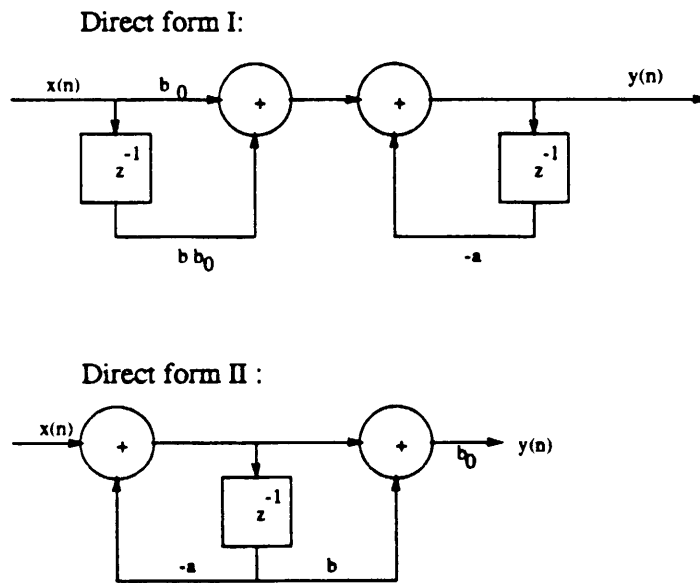

Figure 4.50:

filter is causal, it is also stable. Refer to fig 4.51.

(c)

$$H(z) = b_0 \frac{1 + 0.5z^{-1}}{1 - 0.5z^{-1}}$$

$$\Rightarrow |H(w)|^2 = b_0^2 \frac{\frac{5}{4} + \cos w}{\frac{5}{4} - \cos w}$$

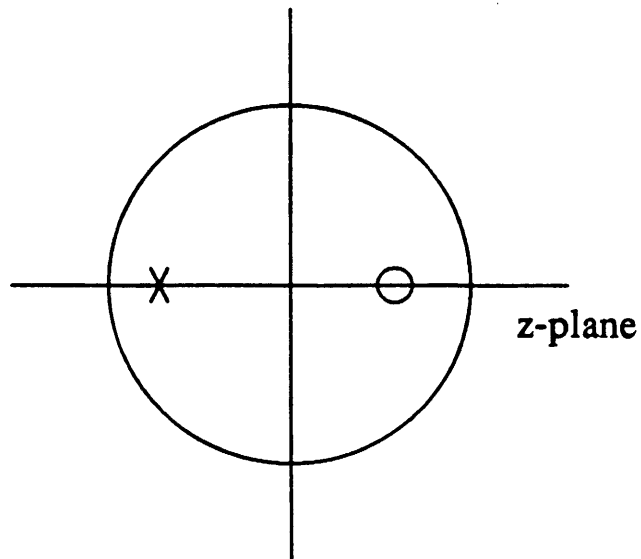

Figure 4.51:

The maximum occurs at $w = 0$. Hence,

$$\begin{aligned}
 H(w)|_{w=0} &= b_0^2 \frac{1}{4} \\
 &= 9b_0^2 = 1 \\
 \Rightarrow b_0 &= \pm \frac{1}{3}
 \end{aligned}$$

(d) Refer to fig 4.52.

(e) Refer to fig 4.53.

obviously, this is a highpass filter. By selecting $b = -1$, the frequency response of the highpass filter is improved.

4.55

$$\begin{aligned}
 |H(w)|^2 &= \frac{A}{[1 + r^2 - 2r\cos(w - \Theta)][1 + r^2 - 2r\cos(w + \Theta)]} \\
 \frac{d}{dw} \frac{1}{|H(w)|^2} &= \frac{1}{A} [2r\sin(w - \Theta)(1 + r^2 - 2r\cos(w + \Theta)) \\
 &\quad + 2r\sin(w + \Theta)(1 + r^2 - 2r\cos(w - \Theta))] \\
 &= 0 \\
 (1 + r^2)(\sin(w - \Theta) + \sin(w + \Theta)) &= 2r[\sin(w - \Theta)\cos(w + \Theta) + \sin(w + \Theta)\cos(w - \Theta)]
 \end{aligned}$$

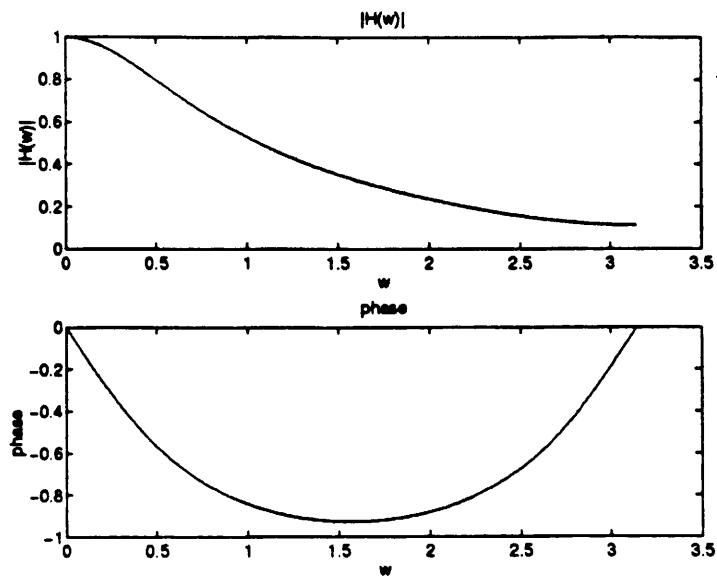

Figure 4.52:

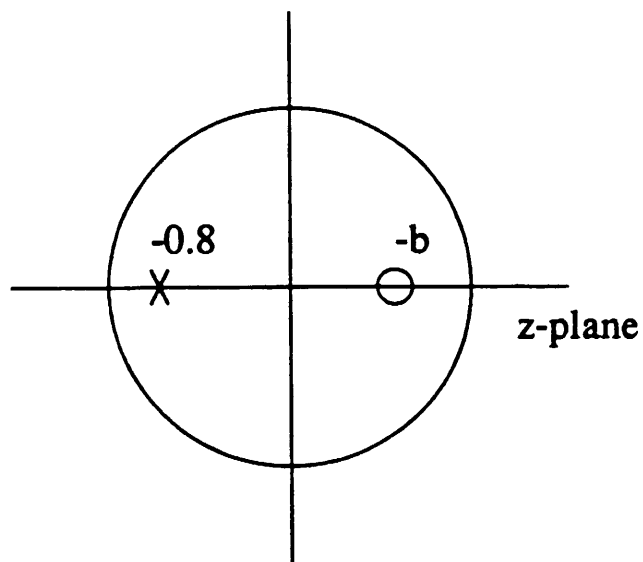

Figure 4.53:

$$\begin{aligned}
 (1+r^2)2\sin w \cos \Theta &= 2r \sin 2w \\
 &= 4r \sin w \cos w \\
 \text{Therefore, } \cos w &= \frac{1+r^2}{2r} \cos \Theta \\
 w_r &= \cos^{-1} \left[\frac{1+r^2}{2r} \cos \Theta \right]
 \end{aligned}$$

4.56

$$\begin{aligned}
 y(n) &= \frac{1}{4}x(n) + \frac{1}{2}x(n-1) + \frac{1}{4}x(n-2) \\
 H(w) &= \frac{1}{4} + \frac{1}{2}e^{-jw} + \frac{1}{4}e^{-j2w} \\
 &= \left(\frac{1+e^{-jw}}{2} \right)^2 \\
 &= e^{-jw} \cos^2 \frac{w}{2} \\
 |H(w)| &= \cos^2 \frac{w}{2} \\
 \Theta(w) &= \angle H(w) = -w
 \end{aligned}$$

Refer to fig 4.54

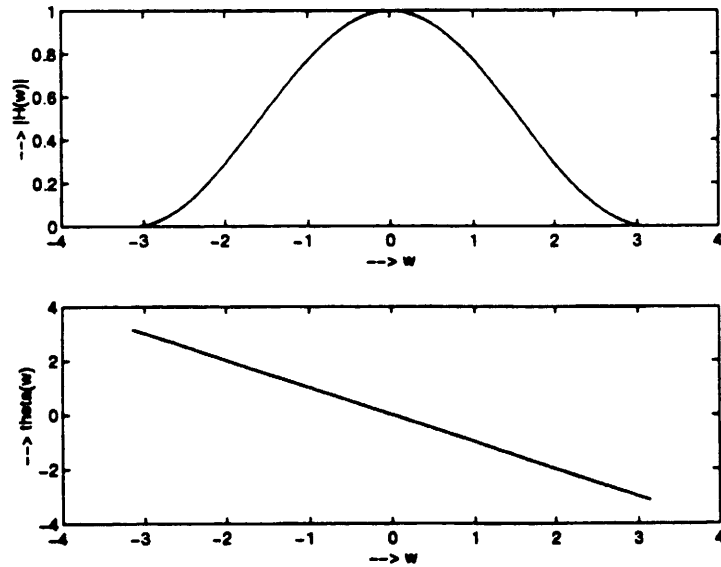

Figure 4.54:

4.57

(a)

$$x(n) = \left(\frac{1}{4}\right)^n u(n) + u(-n-1)$$

$$X(z) = \frac{1}{1 - \frac{1}{4}z^{-1}} + \frac{-1}{1 - z^{-1}}, \text{ ROC: } \frac{1}{4} < |z| < 1$$

$$\begin{aligned} \text{Hence, } H(z) &= \frac{Y(z)}{X(z)} \\ &= \frac{1 - z^{-1}}{1 + z^{-1}}, \text{ ROC: } |z| < 1 \end{aligned}$$

(b)

$$\begin{aligned} Y(z) &= \frac{-\frac{3}{4}z^{-1}}{(1 - \frac{1}{4}z^{-1})(1 + z^{-1})} \\ &= \frac{-\frac{3}{5}}{1 - \frac{1}{4}z^{-1}} + \frac{\frac{3}{5}}{1 + z^{-1}} \\ y(n) &= -\frac{3}{5}\left(\frac{1}{4}\right)^n u(n) - \frac{3}{5}(-1)^n u(-n - 1) \end{aligned}$$

4.58

$$\begin{aligned} y(n) &= b_0 x(n) + b_1 x(n-1) + b_2 x(n-2) \\ H(w) &= b_0 + b_1 e^{-jw} + b_2 e^{-j2w} \end{aligned}$$

(a)

$$H\left(\frac{2\pi}{3}\right) = b_0 + b_1 e^{-j\frac{2\pi}{3}} + b_2 e^{-j\frac{4\pi}{3}} = 0$$

$$H(0) = b_0 + b_1 + b_2 = 1$$

For linear phase, $b_0 = \pm b_2$.

select $b_0 = b_2$ (otherwise $b_1 = 0$).

These conditions yield

$$b_0 = b_1 = b_2 = \frac{1}{3}$$

$$\text{Hence, } H(w) = \frac{1}{3} e^{-jw} (1 + 2\cos w)$$

(b)

$$H(w) = \frac{1}{3} (1 + 2\cos w)$$

$$\Theta(w) = \begin{cases} -w, & \text{for } 1 + 2\cos w > 0 \\ -w + \pi, & \text{for } 1 + 2\cos w < 0 \end{cases}$$

Refer to fig 4.55.

4.59

(a)

$$y(n) = \frac{1}{2M+1} \sum_{k=-M}^M x(n-k)$$

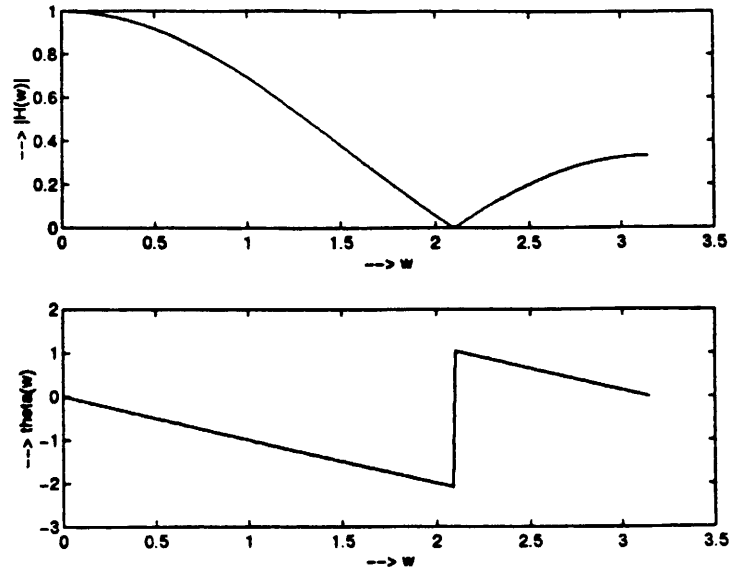

Figure 4.55:

$$\begin{aligned}
 H(w) &= \frac{1}{2M+1} \sum_{k=-M}^M e^{-jwk} \\
 &= \frac{1}{2M+1} \left[1 + 2 \sum_{k=1}^M \cos w k \right]
 \end{aligned}$$

(b)

$$\begin{aligned}
 y(n) &= \frac{1}{4M} x(n+M) + \frac{1}{2M} \sum_{k=-M+1}^{M-1} x(n-k) + \frac{1}{4M} x(n-M) \\
 H(w) &= \frac{1}{2M} \cos Mw + \frac{1}{2M} \left[1 + 2 \sum_{k=1}^{M-1} \cos w k \right]
 \end{aligned}$$

The filter in (b) provides somewhat better smoothing because of its sharper attenuation at the high frequencies.

4.60

(a)

$$\begin{aligned}
 X(f) &= \int_{-\infty}^{\infty} x(t) e^{-j2\pi Ft} dt \\
 &= \int_{-\infty}^{\infty} \left[\int_{-\infty}^{\infty} x_1(t-\tau) x_2(\tau) d\tau \right] e^{-j2\pi Ft} dt \\
 &= \int_{-\infty}^{\infty} x_2(\tau) \left[\int_{-\infty}^{\infty} x_1(t-\tau) e^{-j2\pi F(t-\tau)} dt \right] e^{-j2\pi F\tau} d\tau \\
 &= X_1(F) \int_{-\infty}^{\infty} x_2(\tau) e^{-j2\pi F\tau} d\tau \\
 &= X_1(F) X_2(F)
 \end{aligned}$$

(b)

$$\begin{aligned}x(t) &= \int_{-\frac{\tau}{2}}^{\frac{\tau}{2}+t} 1d\lambda = \tau + t, -\tau \leq t \leq 0 \\ &= \int_{-\frac{\tau}{2}+t}^{\frac{\tau}{2}} 1d\lambda = \tau - t, -\tau > t \geq 0 \\ x(t) &= \begin{cases} \tau - |t|, & |t| \leq \tau \\ 0, & \text{otherwise} \end{cases}\end{aligned}$$

Refer to fig 4.56.

(c)

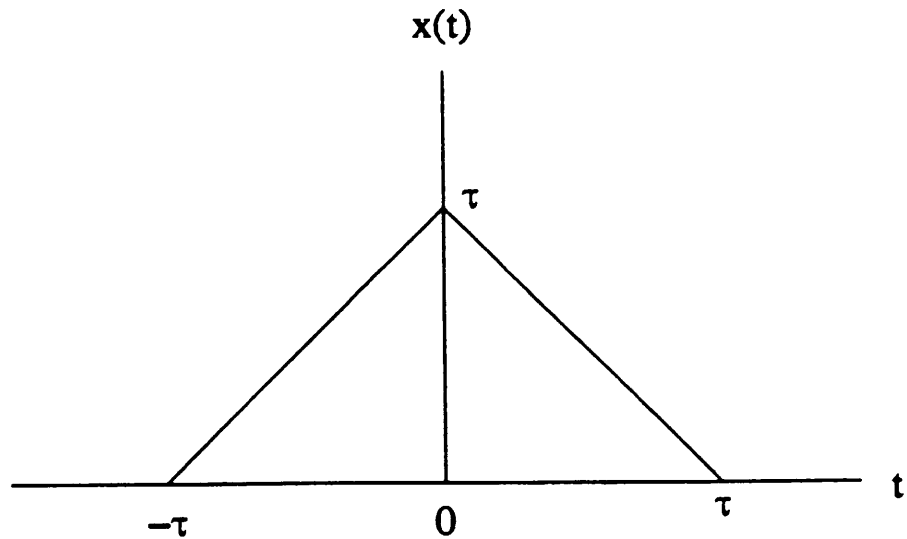

Figure 4.56:

$$\begin{aligned}X_1(F) = X_2(F) &= \int_{-\frac{\tau}{2}}^{\frac{\tau}{2}} e^{-j2\pi Ft} dt \\ &= \left(\frac{\sin \pi F \tau}{\pi F}\right)^2\end{aligned}$$

4.61

$$\begin{aligned}H(z) &= 1 + z + z^2 + \dots + z^8 \\ &= \frac{1 - z^9}{1 - z^{-1}}\end{aligned}$$

$$\begin{aligned}
H(w) &= \frac{1 - e^{-j9w}}{1 - e^{-jw}} \\
&= \frac{e^{-j9w/2} \sin 9w/2}{e^{-jw/2} \sin w/2} \\
&= e^{-j4w} \frac{\sin 9w/2}{\sin w/2} \\
|H(w)| &= \left| \frac{\sin 9w/2}{\sin w/2} \right| \\
\Theta(w) &= -4w, \text{ when } \sin 9w/2 > 0 \\
&= -4w + \pi, \text{ when } \sin 9w/2 < 0 \\
H(w) &= 0, \text{ at } w = \frac{2\pi k}{9}, k = 1, 2, \dots, 8
\end{aligned}$$

The corresponding analog frequencies are $\frac{kF_s}{9}$, $k = 1, 2, 3, 4$, or $\frac{1}{9}$ kHz, $\frac{2}{9}$ kHz, $\frac{3}{9}$ kHz, $\frac{4}{9}$ kHz.

4.62

Refer to fig 4.57.

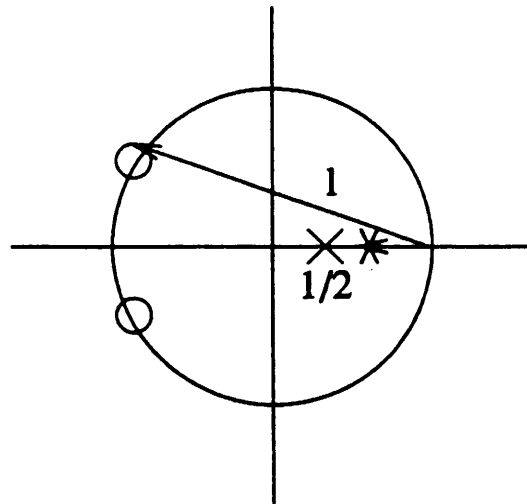

Figure 4.57:

$$\begin{aligned}
H(z) &= G \frac{(1 - e^{j3\pi/4} z^{-1})(1 - e^{-j3\pi/4} z^{-1})}{(1 - \frac{1}{2} z^{-1})^2} \\
H(w) &= H(z)|_{z=e^{jw}}
\end{aligned}$$

$$\begin{aligned}
H(0) &= G \frac{(1 - e^{j3\pi/4})(1 - e^{-j3\pi/4})}{(1 - \frac{1}{2})^2} \\
|H(w)| &= 1 \Rightarrow G \frac{l^2}{4} = 1 \\
l^2 &= 2 + \sqrt{2} \\
G &= \frac{1}{4(2 + \sqrt{2})} = 0.073
\end{aligned}$$

4.63

$$\begin{aligned}
H_z(w) &= 1 - re^{j\theta}e^{-jw} \\
&= 1 - r\cos(w - \theta) + jr\sin(w - \theta)
\end{aligned}$$

(a)

$$\begin{aligned}
|H_z(w)| &= \{[1 - r\cos(w - \theta)]^2 + [r\sin(w - \theta)]^2\}^{\frac{1}{2}} \\
&= [1 + r^2 - 2r\cos(w - \theta)]^{\frac{1}{2}} \\
20\log_{10}|H_z(w)| &= 10\log_{10}[1 - 2r\cos(w - \theta) + r^2]
\end{aligned}$$

Hence proved.

(b)

$$\begin{aligned}
\Theta_z(w) &= \tan^{-1} \frac{\text{imag. part}}{\text{real part}} \\
&= \tan^{-1} \frac{r\sin(w - \theta)}{1 - r\cos(w - \theta)}
\end{aligned}$$

Hence proved.

(c)

$$\begin{aligned}
\tau_g^z(w) &= -\frac{d\Theta_z(w)}{dw} \\
&= -\frac{1}{1 + \frac{r^2 \sin^2(w - \theta)}{[1 - r\cos(w - \theta)]^2}} \frac{[1 - r\cos(w - \theta)]r\cos(w - \theta) - r\sin(w - \theta)(r\sin(w - \theta))}{[1 - r\cos(w - \theta)]^2} \\
&= \frac{r^2 - r\cos(w - \theta)}{1 + r^2 - 2r\cos(w - \theta)}
\end{aligned}$$

Hence proved.

(d) Refer to fig 4.58.

4.64

$$H_p(w) = \frac{1}{1 - re^{j\theta}e^{-jw}}, \quad r < 1$$

(a)

$$\begin{aligned}
|H_p(w)| &= \frac{1}{\{[1 - r\cos(w - \theta)]^2 + [r\sin(w - \theta)]^2\}^{\frac{1}{2}}} \\
&= \frac{1}{|H_z(w)|}
\end{aligned}$$

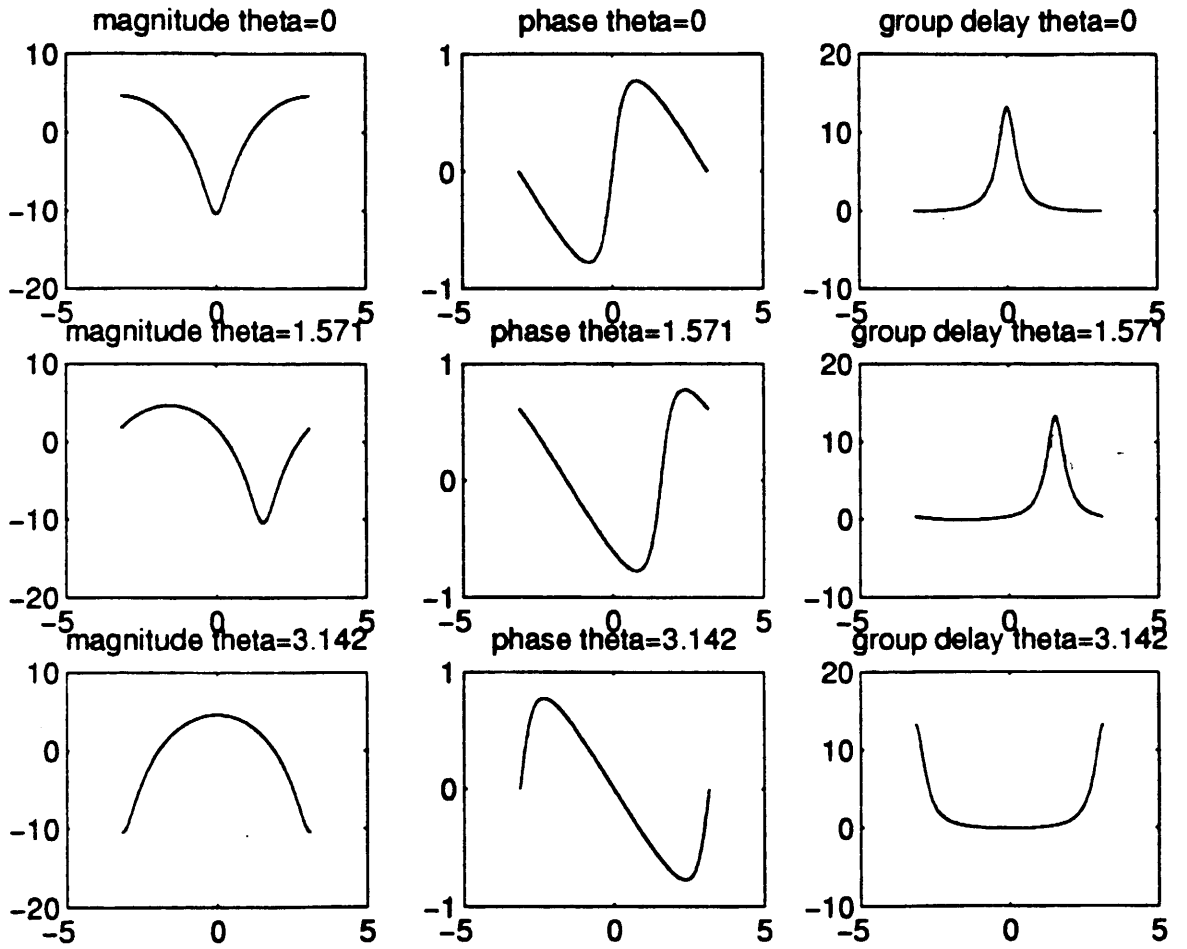

Figure 4.58:

$$\begin{aligned}
|H_p(w)|_{\text{dB}} &= 20\log_{10}\left(\frac{1}{|H_z(w)|}\right) \\
&= -20\log_{10}|H_z(w)| \\
&= -|H_z(w)|_{\text{dB}}
\end{aligned}$$

Hence proved.

(b)

$$\begin{aligned}
H_p(w) &= \frac{1 - r\cos(w - \theta) - jr\sin(w - \theta)}{[1 - r\cos(w - \theta)]^2 + [r\sin(w - \theta)]^2} \\
\Theta_p(w) &= -\tan^{-1} \frac{r\sin(w - \theta)}{1 - r\cos(w - \theta)} \\
&= -\Theta_z(w)
\end{aligned}$$

Hence proved.

(c)

$$\begin{aligned}
\tau_g^p(w) &= -\frac{d\Theta_p(w)}{dw} \\
&= -\frac{d(-\Theta_z(w))}{dw} \\
&= \frac{d\Theta_z(w)}{dw} \\
&= -\tau_g^z(w)
\end{aligned}$$

Hence proved.

4.65

$$\begin{aligned}
H_z(w) &= (1 - re^{j\theta}e^{-jw})(1 - re^{-j\theta}e^{-jw}) \\
&= (1 - re^{-j(w-\theta)})(1 - re^{-j(w+\theta)}) \\
&= A(w)B(w)
\end{aligned}$$

(a)

$$\begin{aligned}
|H_z(w)| &= |A(w)b(w)| \\
&= |A(w)||B(w)| \\
|H_z(w)|_{\text{dB}} &= 20\log_{10}|H_z(w)| \\
&= 10\log_{10}[1 - 2r\cos(w - \theta) + r^2] + 10\log_{10}[1 - 2r\cos(w + \theta) + r^2]
\end{aligned}$$

(b)

$$\begin{aligned}
\angle H_z(w) &= \angle A(w) + \angle B(w) \\
&= \tan^{-1} \frac{r\sin(w - \theta)}{1 - r\cos(w - \theta)} + \tan^{-1} \frac{r\sin(w + \theta)}{1 - r\cos(w + \theta)}
\end{aligned}$$

(c)

$$\begin{aligned}
\tau_g^z(w) &= -\frac{d\Theta_z(w)}{dw} \\
&= \tau_A^z(w) + \tau_B^z(w) \\
&= \frac{r^2 - r\cos(w - \theta)}{1 + r^2 - 2r\cos(w - \theta)} + \frac{r^2 - r\cos(w + \theta)}{1 + r^2 - 2r\cos(w + \theta)}
\end{aligned}$$

(d)

$$H_p(w) = \frac{1}{H_z(w)}$$

$$\text{Therefore, } |H_p(w)| = \frac{1}{|H_z(w)|}$$

$$|H_p(w)|_{\text{dB}} = -|H_z(w)|_{\text{dB}}$$

on the same lines of prob4.62

$$\Theta_p(w) = -\Theta_z(w) \text{ and}$$

$$\tau_g^p(w) = -\tau_g^z(w)$$

(e) Refer to fig 4.59.

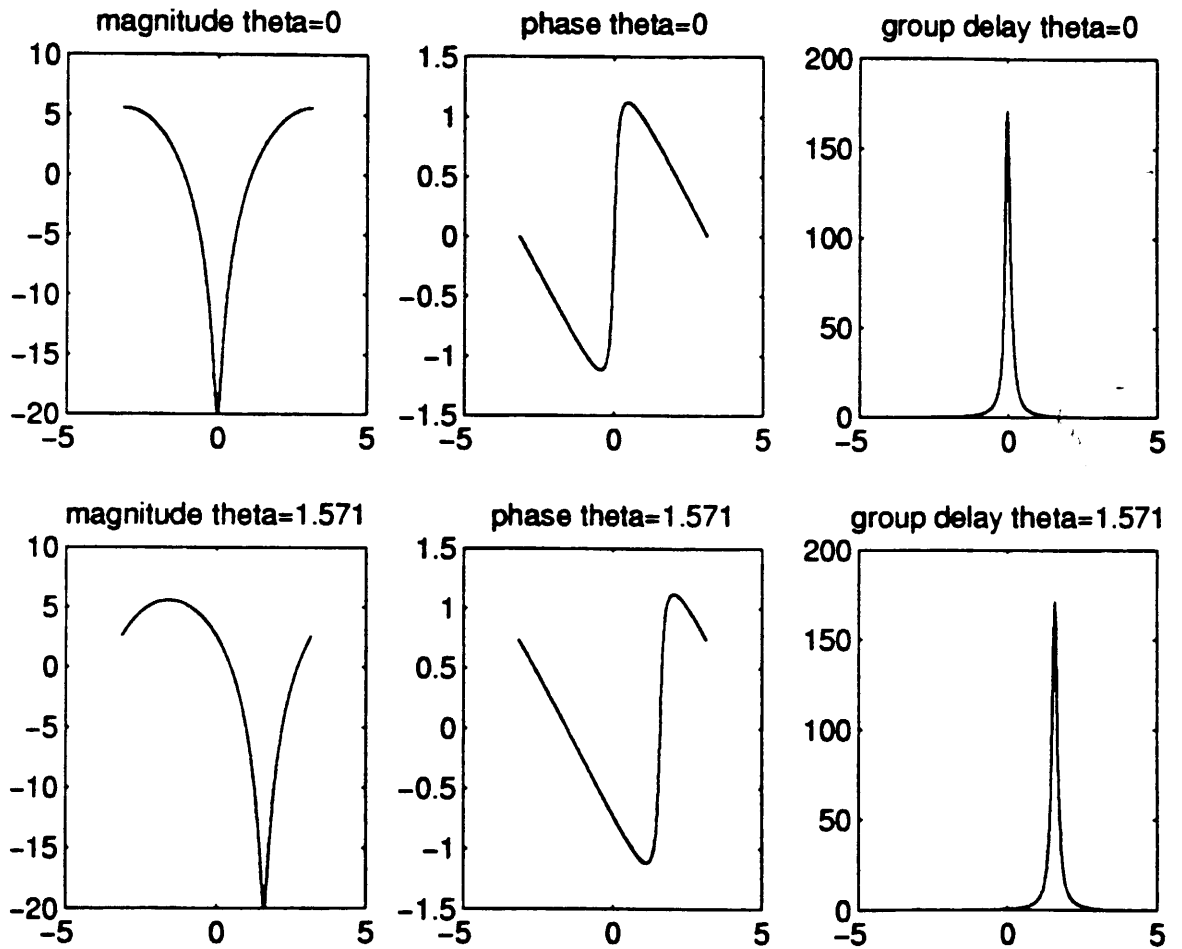

Figure 4.59:

4.66

(a)

$$|H_1(w)|^2 = \frac{(1-a)^2}{(1-a\cos w)^2 + a^2 \sin^2 w}$$

$$|H_1(w)|^2 = \frac{1}{2} \Rightarrow \cos w_1 = \frac{(1-a)^2}{1+a^2-2a\cos w} = \frac{4a-1-a^2}{2a}$$

(b)

$$\begin{aligned} |H_2(w)|^2 &= \left(\frac{1-a}{2}\right)^2 \frac{(1+\cos w)^2 + \sin^2 w}{(1-a\cos w)^2 + a^2 \sin^2 w} \\ &= \frac{(1-a)^2}{2} \frac{2(1+\cos w)}{1+a^2-2a\cos w} \\ |H_2(w)|^2 = \frac{1}{2} &\Rightarrow \cos w_2 = \frac{2a}{1+a^2} \end{aligned}$$

By comparing the results of (a) and (b), we find that $\cos w_2 > \cos w_1$ and, hence $w_2 < w_1$. Therefore, the second filter has a smaller 3dB bandwidth.

4.67

$$\begin{aligned} h(n) &= \cos(w_0 n + \Theta) \\ &= \cos w_0 n \cos \Theta - \sin w_0 n \sin \Theta \end{aligned}$$

use the coupled-form oscillator shown in figure 5.38 and multiply the two outputs by $\cos \Theta$ and $\sin \Theta$, respectively, and add the products, i.e.,

$$y_c(n) \cos \Theta + y_s(n) \sin \Theta = \cos(w_0 n + \Theta)$$

4.68

(a)

$$\begin{aligned} y(n) &= e^{jw_0} y(n-1) + x(n) \\ &= (\cos w_0 + j \sin w_0) [y_R(n-1) + j y_I(n-1)] + x(n) \\ y_R(n-1) + j y_I(n-1) &= \frac{y_R(n) - j y_I(n)}{\cos w_0 + j \sin w_0} \\ &= \frac{y_R(n) \cos w_0 - y_I(n) \sin w_0 + j [y_R(n) \sin w_0 + y_I(n) \cos w_0]}{\cos^2 w_0 + \sin^2 w_0} \end{aligned}$$

(b) Refer to fig 4.60.

(c)

$$\begin{aligned} Y(z) &= e^{jw_0} z^{-1} Y(z) + 1 \\ &= \frac{1}{1 - e^{jw_0} z^{-1}} \\ y(n) &= e^{jn w_0} u(n) \\ &= [\cos w_0 n + j \sin w_0 n] u(n) \\ \text{Hence, } y_R(n) &= \cos w_0 n u(n) \\ y_I(n) &= \sin w_0 n u(n) \end{aligned}$$

(d)

n	0	1	2	3	4	5	6	7	8	9
$y_R(n)$	1	$\frac{\sqrt{3}}{2}$	$\frac{1}{2}$	0	$-\frac{1}{2}$	$-\frac{\sqrt{3}}{2}$	-1	$-\frac{\sqrt{3}}{2}$	$-\frac{1}{2}$	0
$y_I(n)$	0	$\frac{1}{2}$	$\frac{\sqrt{3}}{2}$	1	$\frac{\sqrt{3}}{2}$	$\frac{1}{2}$	0	$-\frac{1}{2}$	$-\frac{\sqrt{3}}{2}$	1

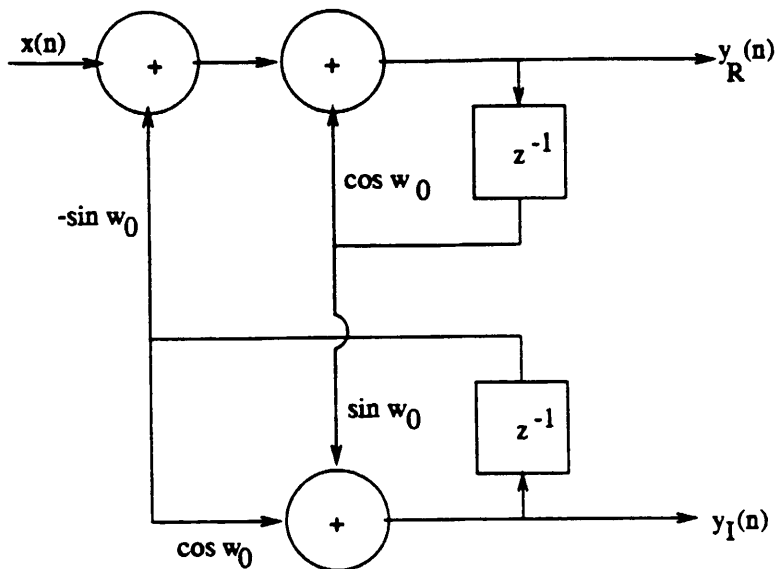

Figure 4.60:

4.69

(a) poles: $p_{1,2} = re^{\pm jw_0}$
 zeros: $z_{1,2} = e^{\pm jw_0}$

(b) For $w = w_0$, $H(w_0) = 0$. For $w \neq w_0$, the poles and zeros factors in $H(w)$ cancel, so that $H(w) = 1$. Refer to fig 4.61.

(c)

$$|H(w)|^2 = G^2 \frac{|1 - e^{jw_0}e^{-jw}|^2 |1 - e^{-jw_0}e^{-jw}|^2}{|1 - re^{jw_0}e^{-jw}|^2 |1 - re^{-jw_0}e^{-jw}|^2}$$

$$= G^2 \left[\frac{2(1 - \cos(w - w_0))}{1 + r^2 - 2r\cos(w - w_0)} \right] \left[\frac{2(1 - r\cos(w + w_0))}{1 + r^2 - 2r\cos(w + w_0)} \right]$$

where $w_0 = \frac{\pi}{3}$. Then

$$\frac{d|H(w)|^2}{dw} = 0 \Rightarrow w = \pi$$

$$|H(\pi)|^2 = 4G^2 \left(\frac{\frac{3}{2}}{1 + r + r^2} \right)^2 = 1$$

$$G = \frac{1}{3}(1 + r + r^2)$$

(d) Refer to fig 4.62.

(e)

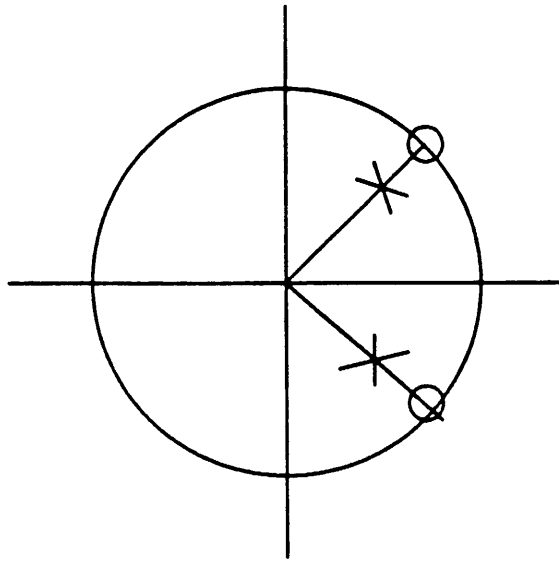

Figure 4.61:

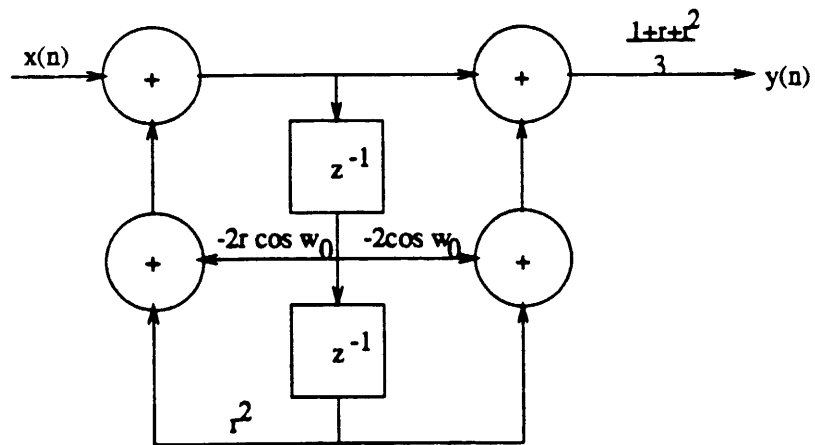

Figure 4.62:

$$|H(w)|^2 = G^2 \frac{|1 - e^{jw_0} e^{-jw}|^2 |1 - e^{-jw_0} e^{-jw}|^2}{|1 - re^{jw_0} e^{-jw}|^2 |1 - re^{-jw_0} e^{-jw}|^2}$$

In the vicinity of $w = w_0$, we have

$$\begin{aligned} |H(w)|^2 &\approx G^2 \frac{|1 - e^{jw_0} e^{-jw}|^2}{|1 - re^{jw_0} e^{-jw}|^2} \\ &= G^2 \left[\frac{2(1 - \cos(w - w_0))}{1 + r^2 - 2r\cos(w - w_0)} \right] = \frac{1}{2} \\ \cos(w - w_0) &= \frac{1 + r^2 - 4G^2}{2r - 4G^2} \\ w_{1,2} &= w_0 \pm \cos^{-1} \left(\frac{1 + r^2 - 4G^2}{2r - 4G^2} \right) \\ B_{3dB} = w_1 - w_2 &= 2\cos^{-1} \left(\frac{1 + r^2 - 4G^2}{2r - 4G^2} \right) \\ &= 2\cos^{-1} \left(1 - \left(\frac{r-1}{\sqrt{2}} \right)^2 \right) \\ &= 2\sqrt{2} \left(\frac{1-r}{\sqrt{2}} \right)^2 \\ &= 2\sqrt{1-r} \end{aligned}$$

4.70

For the sampling frequency $F_s = 500$ samples/sec., the rejected frequency should be $w_1 = 2\pi \left(\frac{60}{100} \right) = \frac{6}{25}\pi$. The filter should have unity gain at $w_2 = 2\pi \left(\frac{200}{500} \right) = \frac{4}{5}\pi$. Hence,

$$\begin{aligned} H\left(\frac{6}{25}\pi\right) &= 0 \\ \text{and } H\left(\frac{4}{5}\pi\right) &= 1 \\ H(w) &= G(1 - e^{j\frac{6}{25}w} e^{-jw})(1 - e^{-j\frac{6}{25}w} e^{-jw}) \\ &= Ge^{-jw} \left[2\cos w - 2\cos \frac{6\pi}{25} \right] \\ H\left(\frac{4}{5}\pi\right) &= 2G \left| \cos\left(\frac{4}{5}\pi\right) - \cos\left(\frac{6}{25}\pi\right) \right| = 1 \\ \text{Hence, } G &= \frac{\frac{1}{2}}{\cos \frac{6}{25}\pi - \cos \frac{4}{5}\pi} \end{aligned}$$

4.71

From (5.4.22) we have,

$$\begin{aligned} H(w) &= b_0 \frac{1 - e^{-j2w}}{(1 - re^{j(w_0-w)})(1 - re^{-j(w_0-w)})} \\ |H(w_0)|^2 &= b_0^2 \frac{|1 - e^{-j2w_0}|^2}{(1-r)^2 [(1 - r\cos 2w_0)^2 + (r\sin 2w_0)^2]} = 1 \\ \text{Hence, } b_0 &= \frac{\sqrt{(1-r)^2 (1 - 2r\cos 2w_0 + r^2)}}{2|\sin w_0|} \end{aligned}$$

4.72

$$\begin{aligned}
 \text{From } \alpha &= (n+1)w_0 \\
 \beta &= (n-1)w_0 \\
 \text{and } \cos\alpha + \cos\beta &= 2\cos\frac{\alpha+\beta}{2}\cos\frac{\alpha-\beta}{2}, \text{ we obtain} \\
 \cos(n+1)w_0 + \cos(n-1)w_0 &= 2\cos w_0 \cos n w_0 \\
 \text{with } y(n) &= \cos w_0 n, \text{ it follows that} \\
 y(n+1) + y(n-1) &= 2\cos w_0 y(n) \text{ or equivalently,} \\
 y(n) &= 2\cos w_0 y(n-1) - y(n-2)
 \end{aligned}$$

4.73

$$\begin{aligned}
 \sin\alpha + \sin\beta &= 2\sin\frac{\alpha+\beta}{2}\cos\frac{\alpha-\beta}{2}, \text{ we obtain} \\
 \text{when } \alpha &= n w_0 \text{ and } \beta = (n-2)w_0, \text{ we obtain} \\
 \sin n w_0 + \sin(n-2)w_0 &= 2\sin(n-1)w_0 \cos w_0 \\
 \text{If } y(n) &= A \sin w_0 n, \text{ then} \\
 y(n) &= 2\cos w_0 y(n-1) - y(n-2) \\
 \text{Initial conditions: } y(-1) &= -A \sin w_0, y(-2) = -A \sin 2w_0
 \end{aligned}$$

4.74

$$\begin{aligned}
 \text{For } h(n) &= A \cos w_0 n u(n) \\
 H(z) &= A \frac{1 - z^{-1} \cos w_0}{1 - 2\cos w_0 z^{-1} + z^{-2}} \\
 \text{Hence, } y(n) &= 2\cos w_0 y(n-1) - y(n-2) + A x(n) - A \cos w_0 x(n-1) \\
 \text{For } h(n) &= A \sin w_0 n u(n) \\
 H(z) &= A \frac{z^{-1} \sin w_0}{1 - 2\cos w_0 z^{-1} + z^{-2}} \\
 \text{Hence, } y(n) &= 2\cos w_0 y(n-1) + y(n-2) + A x(n) - A \sin w_0 x(n-1)
 \end{aligned}$$

4.75

Refer to fig 4.63. $y_1(n) = A \cos n w_0 u(n)$, $y_2(n) = A \sin n w_0 u(n)$

4.76

(a) Replace z by z^8 . We need 8 zeros at the frequencies $\omega = 0, \pm \frac{\pi}{4}, \pm \frac{\pi}{2}, \pm \frac{3\pi}{4}, \pi$ Hence,

$$\begin{aligned}
 H(z) &= \frac{1 - z^{-8}}{1 - a z^{-8}} \\
 &= \frac{Y(z)}{X(z)} \\
 \text{Hence, } y(n) &= a y(n-8) + x(n) - x(n-8)
 \end{aligned}$$

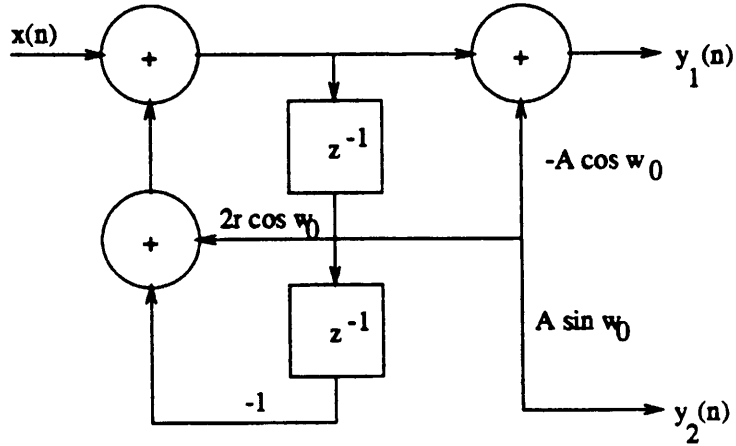

Figure 4.63:

(b) Zeros at $1, e^{\pm j\frac{\pi}{4}}, e^{\pm j\frac{3\pi}{4}}, e^{\pm j\frac{5\pi}{4}}, -1$

Poles at $a^{\frac{1}{4}}, a^{\frac{1}{4}}e^{\pm j\frac{\pi}{4}}, a^{\frac{1}{4}}e^{\pm j\frac{3\pi}{4}}, a^{\frac{1}{4}}e^{\pm j\frac{5\pi}{4}}, -1$. Refer to fig 4.64.

(c)

$$|H(\omega)| = \frac{2|\cos 4\omega|}{\sqrt{1 - 2a\cos 8\omega + a^2}}$$

$$\angle H(\omega) = \begin{cases} -\tan^{-1} \frac{a\sin 8\omega}{1 - a\cos 8\omega}, & \cos 4\omega \geq 0 \\ \pi - \tan^{-1} \frac{a\sin 8\omega}{1 - a\cos 8\omega}, & \cos 4\omega < 0 \end{cases}$$

Refer to fig 4.65.

4.77

We use $F_s/L = 1\text{cycle/day}$. We also choose nulls of multiples of $\frac{1}{14} = 0.071$, which results in a narrow passband of $k \pm 0.067$. Thus, $M + 1 = 14$ or, equivalently $M = 13$

4.78

(a)

$$H(\omega) = \frac{1 - \frac{1}{a}e^{-j\omega}}{1 - ae^{-j\omega}}$$

$$|H(\omega)|^2 = \frac{(1 - \frac{1}{a}\cos\omega)^2 + (\frac{1}{a}\sin\omega)^2}{(1 - a\cos\omega)^2 + (a\sin\omega)^2}$$

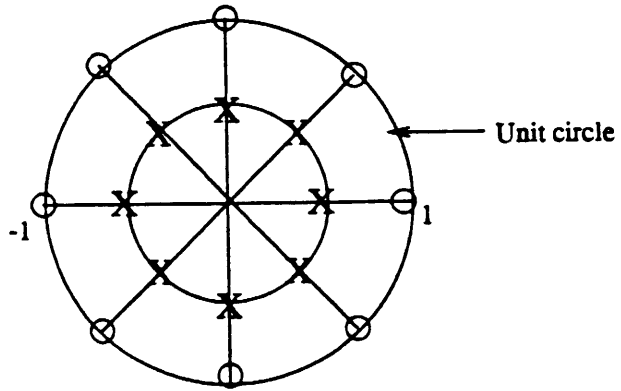

Figure 4.64:

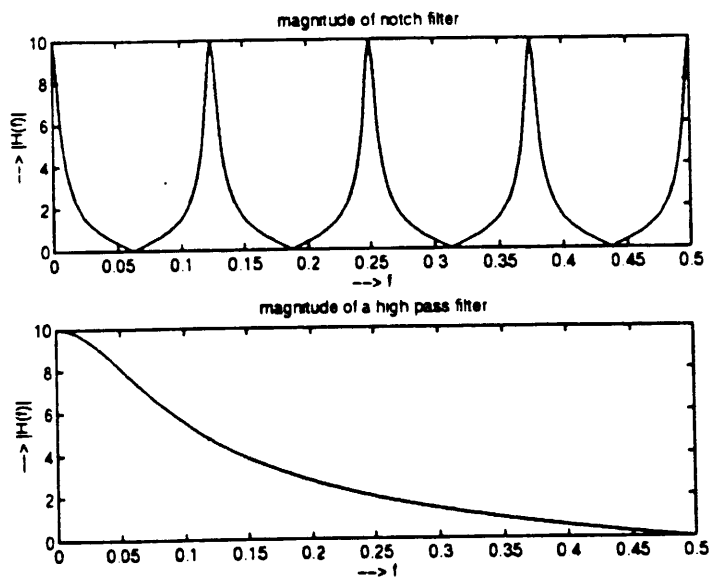

Figure 4.65:

$$= \frac{1 + \frac{1}{a^2} - \frac{2}{a} \cos w}{1 + a^2 - 2a \cos w}$$

$$= \frac{1}{a^2} \text{ for all } w$$

$$\text{Hence, } |H(w)| = \frac{1}{a}$$

For the two-pole, two-zero system,

$$H(w) = \frac{(1 - \frac{1}{r} e^{jw_0} e^{-jw})(1 - \frac{1}{r} e^{-jw_0} e^{-jw})}{(1 - r e^{-jw_0} e^{-jw})(1 - r e^{jw_0} e^{-jw})}$$

$$= \frac{1 - \frac{2}{r} \cos w_0 e^{-jw} + \frac{1}{r^2} e^{-j2w}}{1 - 2r \cos w_0 e^{-jw} + r^2 e^{-j2w}}$$

$$\text{Hence, } |H(w)| = \frac{1}{r^2}$$

$$(b) H(z) = \frac{1 - \frac{2}{r} \cos w_0 z^{-1} + \frac{1}{r^2} z^{-2}}{1 - 2r \cos w_0 z^{-1} + r^2 z^{-2}}$$

Hence, we need two delays and four multiplies per output point.

4.79

(a)

$$w_0 = \frac{60}{200} \cdot 2\pi = \frac{6\pi}{50}$$

$$H(z) = (1 - e^{j\frac{6\pi}{50}} z^{-1})(1 - e^{-j\frac{6\pi}{50}} z^{-1}) b_0$$

$$= b_0 (1 - 2 \cos \frac{6\pi}{50} z^{-1} + z^{-2})$$

$$H(w) = 2b_0 e^{-jw} (\cos w - \cos \frac{6\pi}{50})$$

$$|H(0)| = 2b_0 (1 - \cos \frac{6\pi}{25}) = 1$$

$$b_0 = \frac{1}{2(1 - \cos \frac{6\pi}{25})}$$

(b)

$$H(z) = b_0 \frac{(1 - e^{j\frac{6\pi}{25}} z^{-1})(1 - e^{-j\frac{6\pi}{25}} z^{-1})}{(1 - r e^{j\frac{6\pi}{25}} z^{-1})(1 - r e^{-j\frac{6\pi}{25}} z^{-1})}$$

$$|H(0)| = \frac{2b_0 (1 - \cos \frac{6\pi}{25})}{1 - 2r \cos \frac{6\pi}{25} + r^2} = 1$$

$$b_0 = \frac{1 - 2r \cos \frac{6\pi}{25} + r^2}{2(1 - \cos \frac{6\pi}{25})}$$

4.80

$$h(n) = \{h(0), h(1), h(2), h(3)\} \text{ where } h(0) = -h(3), h(1) = -h(2)$$

$$\text{Hence, } H_r(w) = 2(h(0) \sin \frac{3w}{2} + h(1) \sin \frac{w}{2})$$

$$H_r(\frac{\pi}{4}) = 2h(0) \sin \frac{3\pi}{8} + 2h(1) \sin \frac{\pi}{8} = \frac{1}{2}$$

$$H_r\left(\frac{3\pi}{4}\right) = 2h(0)\sin\frac{9\pi}{8} + 2h(1)\sin\frac{3\pi}{8} = 1$$

$$1.85h(0) + 0.765h(1) = \frac{1}{2}$$

$$-0.765h(0) + 1.85h(1) = 1$$

$$h(1) = 0.56, h(0) = 0.04$$

4.81

(a)

$$H(z) = b_0 \frac{(1-z^{-1})(1+z^{-1})(1-2\cos\frac{3\pi}{4}z^{-1}+z^{-2})}{(1-1.6\cos\frac{2\pi}{9}z^{-1}+0.64z^{-2})(1-1.6\cos\frac{4\pi}{9}z^{-1}+0.64z^{-2})}$$

$$H(w) = b_0 \frac{(2je^{-jw}\sin w)(2e^{-jw})(\cos w - \cos\frac{3\pi}{4})}{(1-1.6\cos\frac{2\pi}{9}e^{-jw}+0.64e^{-j2w})(1-1.6\cos\frac{4\pi}{9}e^{-jw}+0.64e^{-j2w})}$$

$$|H(w)| = b_0 \frac{4|\sin w||\cos w - \cos\frac{3\pi}{4}|}{|1-1.6\cos\frac{2\pi}{9}e^{-jw}+0.64e^{-j2w}||1-1.6\cos\frac{4\pi}{9}e^{-jw}+0.64e^{-j2w}|}$$

$$|H(\frac{5\pi}{12})| = 1 \Rightarrow b_0 = 0.089$$

(b) $H(z)$ as given above.

(c) Refer to fig 4.66. The filter designed is not a good approximation of the desired response.

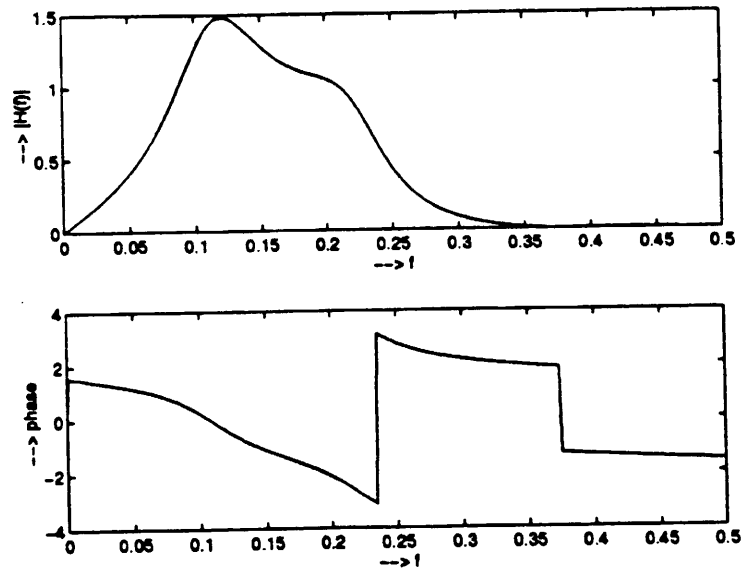

Figure 4.66:

4.82

$$Y(w) = e^{-jw} X(w) + \frac{dX(w)}{dw}$$

(a)

$$\text{For } x(n) = \delta(n), X(w) = 1.$$

$$\begin{aligned}
\text{Hence, } \frac{dX(w)}{dw} &= 0, \text{ and } Y(w) = e^{-jw} \\
h(n) &= \frac{1}{2\pi} \int_{-\pi}^{\pi} Y(w) e^{jwn} dw \\
&= \frac{1}{2\pi} \int_{-\pi}^{\pi} e^{jw(n-1)} dw \\
&= \frac{1}{2\pi j(n-1)} e^{jw(n-1)} \Big|_{-\pi}^{\pi} \\
&= \frac{\sin \pi(n-1)}{\pi(n-1)}
\end{aligned}$$

(b) $y(n) = x(n-1) - jnx(n)$. the system is unstable and time-variant.

4.83

$$\begin{aligned}
H(w) &= \sum_{n=-\infty}^{\infty} h(n) e^{-jwn} \\
&= 1, \quad |w| \leq w_c \\
&= 0, \quad w_c < |w| \pi \\
G(w) &= \sum_{n=-\infty}^{\infty} g(n) e^{-jwn} \\
&= \sum_{n=-\infty}^{\infty} h\left(\frac{n}{2}\right) e^{-jwn} \\
&= \sum_{m=-\infty}^{\infty} h(m) e^{-j2wm} \\
&= H(2w)
\end{aligned}$$

Hence,

$$G(w) = \begin{cases} 1, & |w| \leq \frac{w_c}{2} \text{ and } |w| \geq \pi - \frac{w_c}{2} \\ 0, & \frac{w_c}{2} < |w| < \pi - \frac{w_c}{2} \end{cases}$$

4.84

$y(n) = x(n) - x(n) * h(n) = [\delta(n) - h(n)] * x(n)$ The overall system function is $1 - H(z)$ and the frequency response is $1 - H(w)$. Refer to fig 4.67.

4.85

(a) Since $X(w)$ and $Y(w)$ are periodic, it is observed that $Y(w) = X(w - \pi)$. Therefore, $y(n) = e^{j\pi n} x(n) = (-1)^n x(n)$

(b) $x(n) = (-1)^n y(n)$.

4.86

$$y(n) = 0.9y(n-1) + 0.1x(n)$$

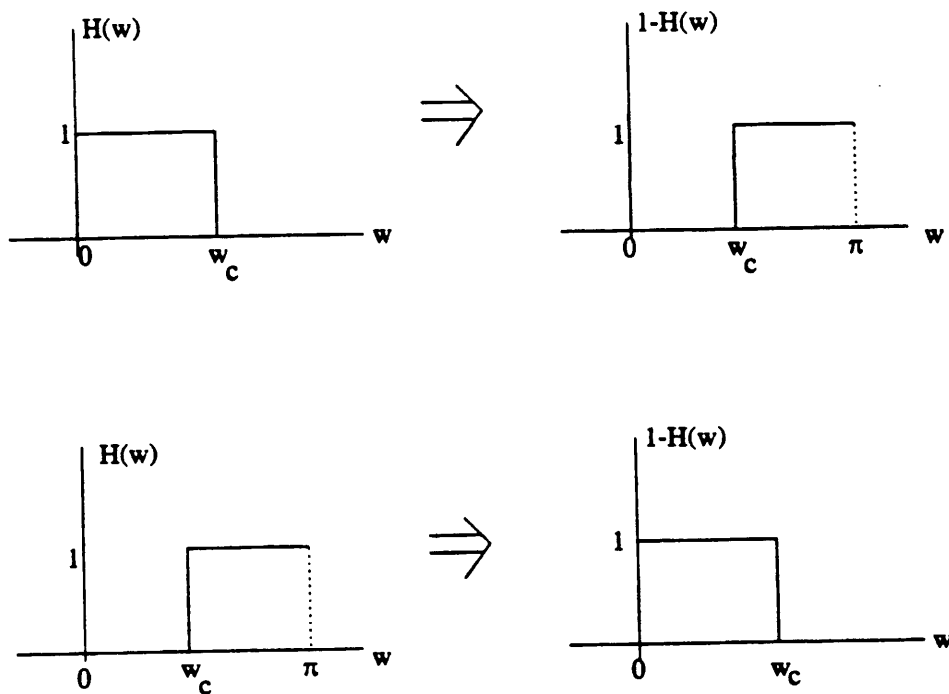

Figure 4.67:

(a)

$$\begin{aligned}
 H(z) &= \frac{0.1}{1 - 0.9z^{-1}} \\
 H_{bp}(w) = H(w - \frac{\pi}{2}) &= \frac{0.1}{1 - 0.9e^{-j(w - \frac{\pi}{2})}} \\
 &= \frac{0.1}{1 - j0.9e^{-jw}}
 \end{aligned}$$

(b) $h(n) = 0.1(0.9e^{j\frac{\pi}{2}})^n u(n)$

(c) Since the impulse response is complex, a real input signal produces a complex-valued output signal. For the output to be real, the bandpass filter should have a complex conjugate pole.

4.87

(a)

$$\begin{aligned}
 \text{Let } g(n) &= nh(n) \\
 \text{Then, } G(w) &= j \frac{dH(w)}{dw} \\
 D &= \sum_{n=-\infty}^{\infty} |g(n)|^2 \\
 &= \frac{1}{2\pi} \int_{-\pi}^{\pi} |G(w)|^2 dw
 \end{aligned}$$

$$\begin{aligned}
&= \frac{1}{2\pi} \int_{-\pi}^{\pi} G(w)G^*(w)dw \\
&= \frac{1}{2\pi} \int_{-\pi}^{\pi} \left[j \frac{dH(w)}{dw} (-j) \left(\frac{dH(w)}{dw} \right)^* \right] dw \\
\text{But } \frac{dH(w)}{dw} &= \left[\frac{dH(w)}{dw} + j|H(w)| \frac{d\Theta(w)}{dw} \right] e^{j\Theta(w)}
\end{aligned}$$

Therefore,

$$D = \frac{1}{2\pi} \int_{-\pi}^{\pi} \left\{ \left[\frac{dH(w)}{dw} \right]^2 + |H(w)|^2 \left[\frac{d\Theta(w)}{dw} \right]^2 \right\} dw$$

(b) D consists of two terms, both of which are positive. For $|H(w)| \neq 0$, D is minimized by selecting $\Theta(w) = 0$, in which case the second term becomes zero.

4.88

$$y(n) = ay(n-1) + bx(n), 0 < a < 1$$

$$H(z) = \frac{b}{1 - az^{-1}}$$

(a)

$$H(w) = \frac{b}{1 - ae^{-jw}}$$

$$|H(0)| = \frac{|b|}{1-a} = 1$$

$$b = \pm(1-a)$$

(b)

$$|H(w)|^2 = \frac{b^2}{1 + a^2 - 2a\cos w} = \frac{1}{2}$$

$$\Rightarrow 2b^2 = 1 + a^2 - 2a\cos w$$

$$\cos w = \frac{1}{2a} [1 + a^2 - 2(1-a)^2]$$

$$= \frac{1}{2a} (4a - 1 - a^2)$$

$$w_3 = \cos^{-1} \left(\frac{4a - 1 - a^2}{2a} \right)$$

(c)

$$w_3 = \cos^{-1} \left(1 - \frac{(a-1)^2}{2a} \right)$$

$$\text{Let } f(a) = 1 - \frac{(a-1)^2}{2a}$$

$$\begin{aligned}
\text{Then } f'(a) &= -\frac{a^2 - 1}{2a^2} \\
&= \frac{1 - a^2}{2a^2} > 0
\end{aligned}$$

Therefore $f(a)$ is maximum at $a = 1$ and decreases monotonically as $a \rightarrow 0$. Consequently, w_3 increases as $a \rightarrow 0$.

(d)

$$b = \pm(1 - a)$$
$$w_3 = \cos^{-1}\left(\frac{4a - 1 - a^2}{2a}\right)$$

The 3-dB bandwidth increases as $a \rightarrow 0$.

4.89

$$y(n) = x(n) + \alpha x(n - M), \alpha > 0$$
$$H(w) = 1 + \alpha e^{-jwM}$$
$$|H(w)| = \sqrt{1 + 2\alpha \cos wM + \alpha^2}$$
$$\Theta(w) = \tan^{-1} \frac{-\alpha \sin wM}{1 + \alpha \cos wM}$$

Refer to fig 4.68.

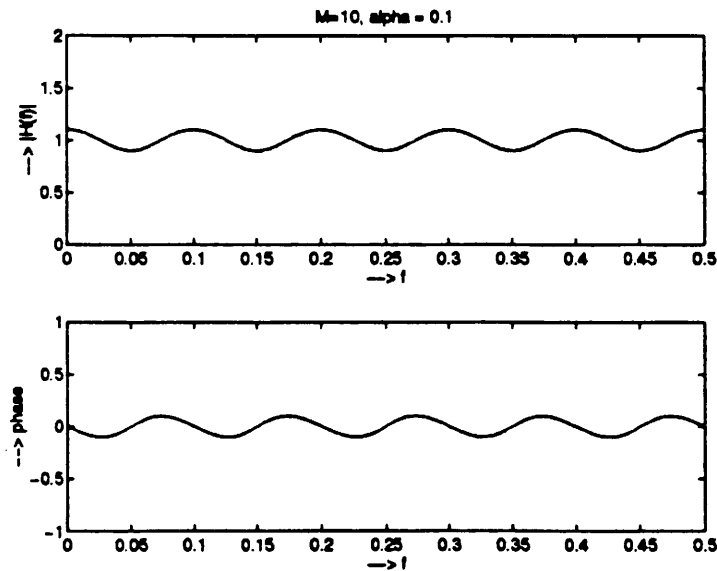

Figure 4.68:

4.90

(a)

$$Y(z) = \frac{1}{2} [X(z) + z^{-1}X(z)]$$
$$H(z) = \frac{Y(z)}{X(z)}$$
$$= \frac{1}{2}(1 + z^{-1})$$
$$= \frac{z + 1}{2z}$$

Zero at $z = -1$ and a pole at $z = 0$. The system is stable.

(b)

$$\begin{aligned} Y(z) &= \frac{1}{2} [-X(z) + z^{-1}X(z)] \\ H(z) &= \frac{Y(z)}{X(z)} \\ &= \frac{1}{2}(-1 + z^{-1}) \\ &= -\frac{z-1}{2z} \end{aligned}$$

Zero at $z = 1$ and a pole at $z = 0$. The system is stable.

(c)

$$\begin{aligned} Y(z) &= \frac{1}{8}(1 + z^{-1})^3 \\ &= \frac{1}{8} \frac{(1+z)^3}{z^3} \end{aligned}$$

Three zeros at $z = -1$ and three poles at $z = 0$. The system is stable.

4.91

$$\begin{aligned} Y(z) &= X(z) + bz^{-2}X(z) + z^{-4}X(z) \\ H(z) &= \frac{Y(z)}{X(z)} \\ &= 1 + bz^{-2} + z^{-4} \\ \text{For } b = 1, H(w) &= 1 + e^{j2w} + e^{-j4w} \\ &= (1 + 2\cos w)e^{-jw} \\ |H(w)| &= |1 + 2\cos w| \\ \angle H(w) &= \begin{cases} -w, & 1 + 2\cos w \geq 0 \\ \pi - w, & 1 + 2\cos w < 0 \end{cases} \end{aligned}$$

Refer to fig 4.69.

$$\begin{aligned} b = -1, H(w) &= 1 - e^{-jw} + e^{-j2w} \\ &= (2\cos w - 1)e^{-jw} \\ |H(w)| &= |2\cos w - 1| \\ \angle H(w) &= \begin{cases} -w, & -1 + 2\cos w \geq 0 \\ \pi - w, & -1 + 2\cos w < 0 \end{cases} \end{aligned}$$

Refer to fig 4.70.

4.92

$$y(n] = x(n) - 0.95x(n - 6)$$

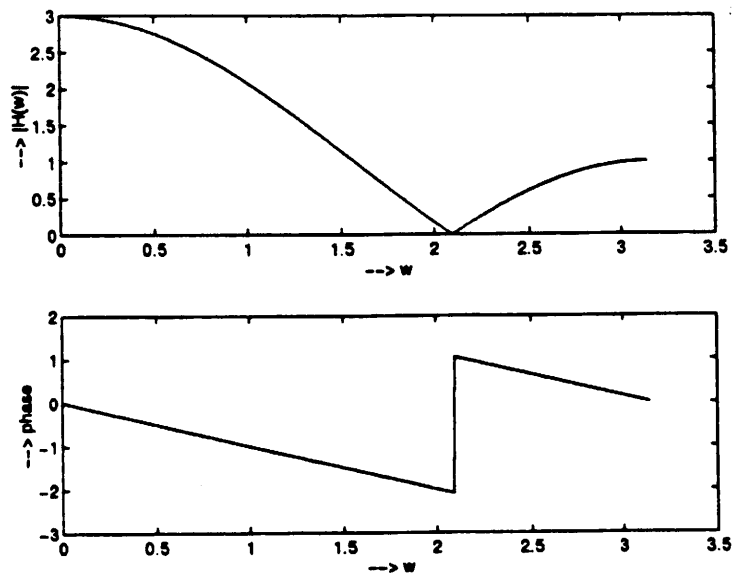

Figure 4.69:

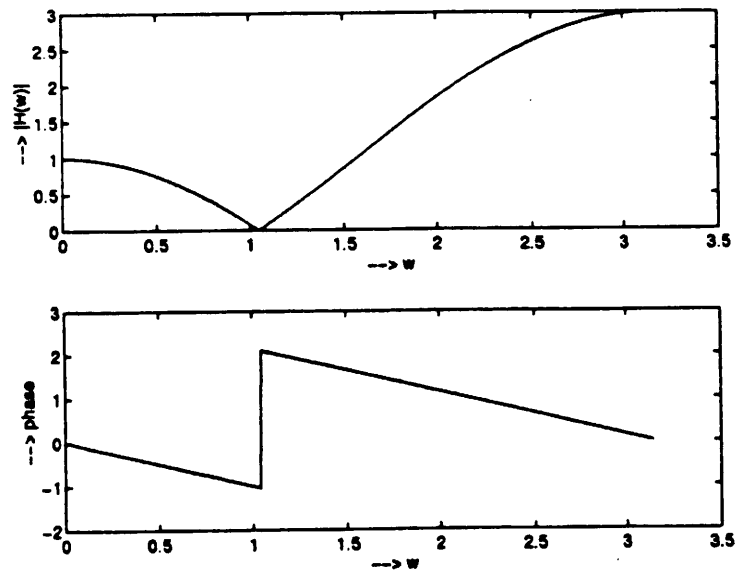

Figure 4.70:

(a)

$$\begin{aligned} Y(z) &= X(z)(1 - 0.95z^{-6}) \\ H(z) &= (1 - 0.95z^{-6}) \\ &= \frac{z^6 - 0.95}{z^6} \\ z^6 &= 0.95 \\ z &= (0.95)^{\frac{1}{6}} e^{j2\pi k/6}, k = 0, 1, \dots, 5 \end{aligned}$$

6th order pole at $z = 0$. Refer to fig 4.71.

(b) Refer to fig 4.72.

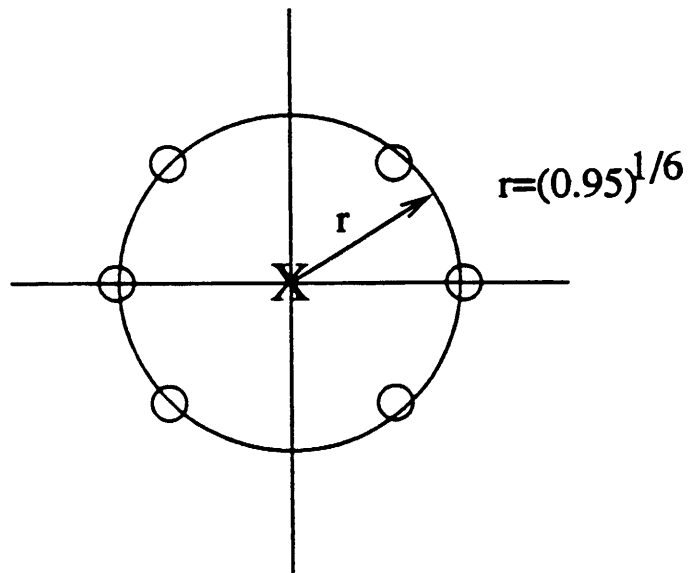

Figure 4.71:

(c) $H_{in}(z) = \frac{z^6}{z^6 - 0.95}$. $r = (0.95)^{\frac{1}{6}}$. Refer to fig 4.73.

(d) Refer to fig 4.74.

4.93

(a)

$$\begin{aligned} H(z) &= \frac{z^{-1}}{1 - z^{-1} - z^{-2}} \\ &= \frac{z^{-1}}{(1 - \frac{1+\sqrt{5}}{2}z^{-1})(1 - \frac{1-\sqrt{5}}{2}z^{-1})} \end{aligned}$$

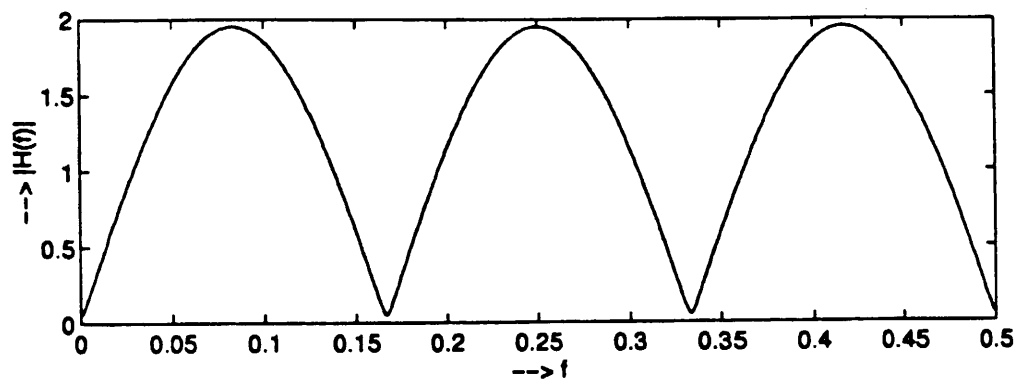

Figure 4.72:

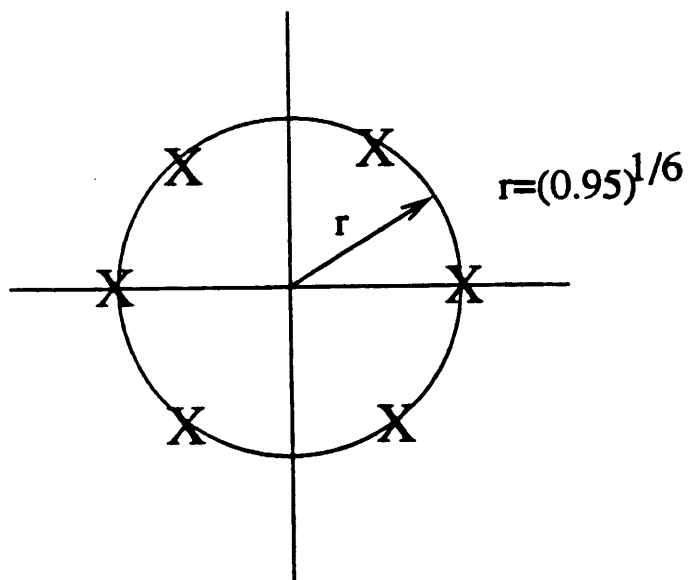

Figure 4.73:

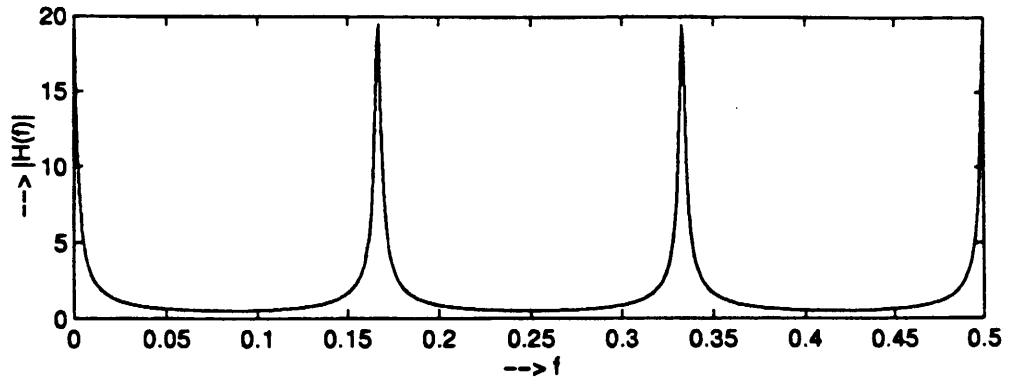

Figure 4.74:

$$= \frac{\frac{1}{\sqrt{5}}}{1 - \frac{1+\sqrt{5}}{2}z^{-1}} + \frac{-\frac{1}{\sqrt{5}}}{1 - \frac{1-\sqrt{5}}{2}z^{-1}}$$

If $|z| > 1 - \frac{1+\sqrt{5}}{2}$ is ROC, then

$$h(n) = \left[\frac{1}{\sqrt{5}} \left(\frac{1+\sqrt{5}}{2} \right)^n - \frac{1}{\sqrt{5}} \left(\frac{1-\sqrt{5}}{2} \right)^n \right] u(n)$$

If ROC is $\frac{\sqrt{5}-1}{2} < |z| < \frac{\sqrt{5}+1}{2}$, then

$$h(n) = -\frac{1}{\sqrt{5}} \left(\frac{1-\sqrt{5}}{2} \right)^n u(n) - \frac{1}{\sqrt{5}} \left(\frac{1+\sqrt{5}}{2} \right)^n u(-n-1)$$

If $|z| < 1 - \frac{\sqrt{5}-1}{2}$ is ROC, then

$$h(n) = \left[-\frac{1}{\sqrt{5}} \left(\frac{1+\sqrt{5}}{2} \right)^n + \frac{1}{\sqrt{5}} \left(\frac{1-\sqrt{5}}{2} \right)^n \right] u(-n-1)$$

From $H(z)$, the difference equation is

$$y(n) = y(n-1) + y(n-2) + x(n-1)$$

(b)

$$H(z) = \frac{1}{1 - e^{-4a}z^{-4}}$$

The difference equation is

$$y(n) = e^{-4a}y(n-1) + x(n)$$

$$\begin{aligned} H(z) &= \frac{1}{(1 - e^{-a}z^{-1})(1 - e^{j\frac{\pi}{2}}e^{-a}z^{-1})(1 - e^{-a}z^{-1})(1 + je^{-a}z^{-1})} \\ &= \frac{\frac{1}{4}}{1 - e^{-a}z^{-1}} + \frac{\frac{1}{4}}{1 - je^{-a}z^{-1}} + \frac{\frac{1}{4}}{1 + e^{-a}z^{-1}} + \frac{\frac{1}{4}}{1 + je^{-a}z^{-1}} \end{aligned}$$

If ROC is $|z| > 1$, then

$$h(n) = \frac{1}{4} [1 + (j)^n + (-1)^n + (-j)^n] e^{-an} u(n)$$

If ROC is $|z| < 1$, then

$$h(n) = -\frac{1}{4} [1 + (j)^n + (-1)^n + (-j)^n] e^{-an} u(-n-1)$$

4.94

$$\begin{aligned}
Y(z) &= 1 - z^{-1} + 3z^{-2} - z^{-3} + 6z^{-4} \\
&= (1 + z^{-1} + 2z^{-2})(1 - 2z^{-1} + 3z^{-2}) \\
X(z) &= 1 + z^{-1} + 2z^{-2} \\
\text{Therefore, } H(z) &= \frac{Y(z)}{X(z)} \\
&= 1 - 2z^{-1} + 3z^{-2} \\
h(n) &= \left\{ \underset{\uparrow}{1}, -2, 3 \right\}
\end{aligned}$$

4.95

$$\begin{aligned}
y(n) &= \frac{1}{2}y(n-1) + x(n) \\
x(n) &= \left(\frac{1}{4}\right)^n u(n) \\
H(z) &= \frac{Y(z)}{X(z)} \\
&= \frac{1}{1 - \frac{1}{2}z^{-1}} \\
X(z) &= \frac{1}{1 - \frac{1}{4}z^{-1}} \\
Y(z) &= \frac{1}{(1 - \frac{1}{4}z^{-1})(1 - \frac{1}{2}z^{-1})} \\
R_{xx}(z) &= X(z)X(z^{-1}) \\
&= \frac{1}{(1 - \frac{1}{4}z^{-1})(1 - \frac{1}{4}z)} \\
&= \frac{-4z^{-1}}{(1 - \frac{1}{4}z^{-1})(1 - 4z^{-1})} \\
&= \frac{16}{15} \frac{1}{1 - \frac{1}{4}z^{-1}} - \frac{16}{15} \frac{1}{1 - 4z^{-1}} \\
\text{Hence, } r_{xx}(n) &= \frac{16}{15} \left(\frac{1}{4}\right)^n u(n) + \frac{16}{15} (4)^n u(-n-1) \\
R_{hh}(z) &= H(z)H(z^{-1}) \\
&= \frac{1}{(1 - \frac{1}{2}z^{-1})(1 - \frac{1}{2}z)} \\
&= \frac{-2z^{-1}}{(1 - \frac{1}{2}z^{-1})(1 - 2z^{-1})} \\
&= \frac{4}{3} \frac{1}{1 - \frac{1}{2}z^{-1}} - \frac{4}{3} \frac{1}{1 - 2z^{-1}} \\
\text{Hence, } r_{hh}(n) &= \frac{4}{3} \left(\frac{1}{2}\right)^n u(n) + \frac{4}{3} (2)^n u(-n-1) \\
R_{xy}(z) &= X(z)Y(z^{-1}) \\
&= \frac{1}{(1 - \frac{1}{4}z^{-1})(1 - \frac{1}{4}z)(1 - \frac{1}{2}z)}
\end{aligned}$$

$$\begin{aligned}
&= -\frac{16}{17} \frac{1}{1-2z^{-1}} + \frac{16}{15} \frac{1}{1-4z^{-1}} + \frac{128}{105} \frac{1}{1-\frac{1}{4}z^{-1}} \\
\text{Hence, } r_{xy}(n) &= \frac{16}{17}(2)^n u(-n-1) - \frac{16}{15}(4)^n u(-n-1) + \frac{128}{105} \left(\frac{1}{4}\right)^n u(n) \\
R_{yy}(z) &= Y(z)Y(z^{-1}) \\
&= \frac{1}{(1-\frac{1}{4}z^{-1})(1-\frac{1}{2}z^{-1})(1-\frac{1}{4}z)(1-\frac{1}{2}z)} \\
&= -\frac{64}{21} \frac{1}{1-2z^{-1}} + \frac{128}{105} \frac{1}{1-4z^{-1}} + \frac{64}{21} \frac{1}{1-\frac{1}{2}z^{-1}} - \frac{128}{105} \frac{1}{1-\frac{1}{4}z^{-1}} \\
\text{Hence, } r_{yy}(n) &= \frac{64}{21}(2)^n u(-n-1) - \frac{128}{105}(4)^n u(-n-1) + \frac{64}{21} \left(\frac{1}{2}\right)^n u(n) - \frac{128}{105} \left(\frac{1}{4}\right)^n u(n)
\end{aligned}$$

4.96

(a) $h(n) = \{10, 9, -7, -8, 0, 5, 3\}$

The roots(zeros) are $0.8084 \pm j0.3370, -0.3750 \pm j0.6074, -1.0, -0.7667$

All the roots of $H(z)$ are inside the unit circle. Hence, the system is minimum phase.

(b) $h(n) = \{5, 4, -3, -4, 0, 2, 1\}$ $H(z) = 5 + 4z^{-1} - 3z^{-2} - 4z^{-3} + 2z^{-5} + z^{-6}$

The roots(zeros) are $0.7753 \pm j0.2963, -0.4219 \pm j0.5503, -0.7534 \pm j0.1900$

All the roots of $H(z)$ are inside the unit circle. Hence, the system is minimum phase.

4.97

The impulse response satisfies the difference equation

$$\begin{aligned}
\sum_{k=0}^N a_k h(n-k) &= \delta(n), a_0 = 1 \\
n=0, \Rightarrow \sum_{k=0}^N a_k h(-k) &= a_0 h(0) = 1 \\
a_0 &= \frac{1}{h(0)} \\
n=1, \Rightarrow a_0 h(1) + a_1 h(0) &= 0 \\
a_1 &= \frac{-a_0 h(1)}{h(0)} = \frac{-h(1)}{h^2(0)} \\
&\vdots \\
n=N, \Rightarrow a_0 h(N) + a_1 h(N-1) + \dots + a_N h(0) &\Rightarrow \text{yields } a_N
\end{aligned}$$

It is apparent that the coefficients $\{a_n\}$ can be determined if we know the order N and the values $h(0), h(1), \dots, h(N)$. If we do not know the filter order N , we cannot determine the $\{a_n\}$.

4.98

$h(n) = b_0 \delta(n) + b_1 \delta(n-D) + b_2 \delta(n-2D)$ (a) If the input to the system is $x(n)$, the output is $y(n) = b_0 x(n) + b_1 x(n-D) + b_2 x(n-2D)$. Hence, the output consists of $x(n)$, which is the input signal, and the delayed signals $x(n-D)$ and $x(n-2D)$. The latter may be thought of as echoes of $x(n)$.

(b)

$$\begin{aligned}
 H(w) &= b_0 + b_1 e^{-jwD} + b_2 e^{-j2wD} \\
 &= b_0 + b_1 \cos wD + b_2 \cos 2wD - j(b_1 \sin wD + b_2 \sin 2wD) \\
 |H(w)| &= \sqrt{b_0^2 + b_1^2 + b_2^2 + 2b_1(b_0 + b_2)\cos wD + 2b_0 b_2 \cos 2wD} \\
 \Theta(w) &= -\tan^{-1} \frac{b_1 \sin wD + b_2 \sin 2wD}{b_0 + b_1 \cos wD + b_2 \cos 2wD}
 \end{aligned}$$

(c) If $|b_0 + b_2| \ll |b_1|$, then the dominant term is $b_1 e^{-jwD}$ and

$$|H(w)| = \sqrt{b_0^2 + b_1^2 + b_2^2 + 2b_1(b_0 + b_2)\cos wD}$$

and $|H(w)|$ has maxima and minima at $w = \pm \frac{k}{D}\pi, k = 0, 1, 2, \dots$

(d) The phase $\Theta(w)$ is approximately linear with a slope of $-D$. Refer to fig 4.75.

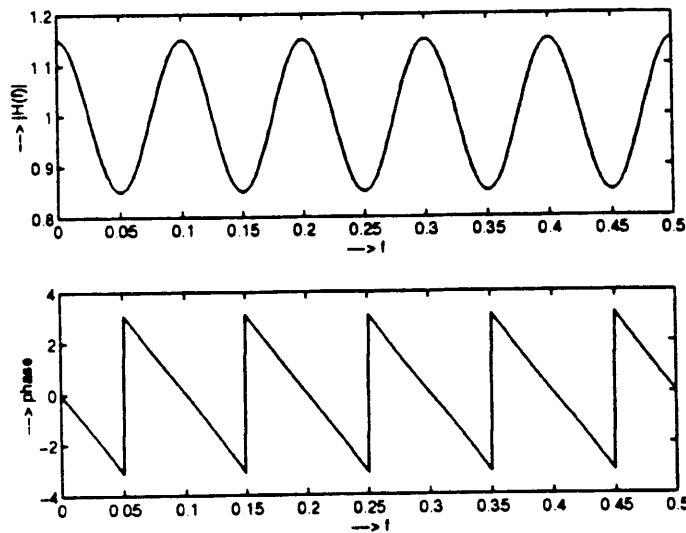

Figure 4.75:

4.99

$$H(z) = \frac{B(z)}{A(z)} = \frac{1 + bz^1}{1 + az^1} = \sum_{n=0}^{\infty} h(n)z^{-n}$$

(a)

$$H(z) = 1 + (b - a)z^{-1} + (a^2 - ab)z^{-2} + (a^2b - a^3)z^{-3} + (a^4 - a^3b)z^{-5} + \dots$$

Hence, $h(0) = 1,$

$$h(1) = b - a,$$

$$h(2) = a^2 - ab,$$

$$h(3) = a^2b - a^3,$$

$$h(4) = a^4 - a^3b$$

(b)

$$y(n) + ay(n-1) = x(n) + bx(n-1)$$

$$\text{For } x(n) = \delta(n),$$

$$h(n) + ah(n-1) = \delta(n) + b\delta(n-1)$$

Multiply both sides by $h(n)$ and sum. Then

$$r_{hh}(0) + ar_{hh}(1) = h(0) + bh(1)$$

$$r_{hh}(1) + ar_{hh}(0) = bh(0)$$

$$r_{hh}(2) + ar_{hh}(1) = 0$$

$$r_{hh}(3) + ar_{hh}(2) = 0$$

By solving these equations recursively, we obtain

$$r_{hh}(0) = \frac{b^2 - 2ab + 1}{1 - a^2}$$

$$r_{hh}(1) = \frac{(ab - 1)(a - b)}{1 - a^2}$$

$$r_{hh}(2) = -a \frac{(ab - 1)(a - b)}{1 - a^2}$$

$$r_{hh}(3) = a^2 \frac{(ab - 1)(a - b)}{1 - a^2}$$

4.100

$x(n)$ is a real-valued, minimum-phase sequence. The sequence $y(n)$ must satisfy the conditions, $y(0) = x(0)$, $|y(n)| = |x(n)|$, and must be minimum phase. The solution that satisfies the condition is $y(n) = (-1)^n x(n)$. The proof that $y(n)$ is minimum phase proceeds as follows:

$$\begin{aligned} Y(z) &= \sum_n y(n)z^{-n} \\ &= \sum_n (-1)^n x(n)z^{-n} \\ &= \sum_n x(n)(-z^{-1})^n \\ &= X(-z) \end{aligned}$$

This preserves the minimum phase property since a factor $(1 - \alpha z^{-1}) \rightarrow (1 + \alpha z^{-1})$

4.101

Consider the system with real and even impulse response $h(n) = \{\frac{1}{4}, 1, \frac{1}{4}\}$ and frequency response $H(\omega) = 1 + \frac{1}{2}\cos\omega$. Then $H(z) = z^{-1}(\frac{1}{4}z^2 + z + \frac{1}{4})$. The system has zeros at $z = -2 \pm \sqrt{3}$. We observe that the system is stable, and its frequency response is real and even. However, the inverse system is unstable. Therefore, the stability of the inverse system is not guaranteed.

4.102

(a)

$$g(n) = h(n) * x(n) \Rightarrow G(w) = H(w)X(w)$$

$$f(n) = h(n) * g(-n) \Rightarrow F(w) = H(w)G(-w)$$

$$\begin{aligned}
Y(w) &= F(-w) \\
\text{Then, } Y(w) &= H(-w)G(w) \\
&= H(-w)H(w)X(w) \\
&= H^*(w)H(w)X(w) \\
&= |H(w)|^2 X(w)
\end{aligned}$$

But $H_a(w) \equiv |H(w)|^2$ is a zero-phase system.

(b)

$$\begin{aligned}
G(w) &= H(w)X(w) \\
F(w) &= H(w)X(-w) \\
Y(w) &= G(w) + F(-w) \\
&= H(w)X(w) + H(-w)X(w) \\
&= X(w)(H(w) + H^*(-w)) \\
&= 2X(w)\text{Re}\{H(w)\}
\end{aligned}$$

But $H_b(w) = 2\text{Re}\{H(w)\}$ is a zero-phase system.

4.103

(a) Correct. The zeros of the resulting system are the combination of the zeros of the two systems. Hence, the resulting system is minimum phase if the individual systems are minimum phase.

(b) Incorrect. For example, consider the two minimum-phase systems.

$$\begin{aligned}
H_1(z) &= \frac{1 - \frac{1}{2}z^{-1}}{1 - \frac{1}{3}z^{-1}} \\
\text{and } H_2(z) &= \frac{-2(1 + \frac{1}{3}z^{-1})}{1 - \frac{1}{3}z^{-1}}
\end{aligned}$$

Their sum is $H_1(z) + H_2(z) = \frac{-1 - \frac{7}{6}z^{-1}}{1 - \frac{1}{3}z^{-1}}$, which is not minimum phase.

4.104

(a)

$$\begin{aligned}
|H(w)|^2 &= \frac{\frac{5}{4} - \cos w}{\frac{10}{9} - \frac{2}{3}\cos w} \\
&= H(z)H(z^{-1})|_{z=e^{-jw}} \\
\text{Hence, } H(z)H(z^{-1}) &= \frac{\frac{5}{4} - \frac{1}{2}(z + z^{-1})}{\frac{10}{9} - \frac{1}{3}(z + z^{-1})} \\
&= \frac{1 - \frac{1}{2}z^{-1}}{1 - \frac{1}{3}z^{-1}}
\end{aligned}$$

(b)

$$\begin{aligned}
|H(w)|^2 &= \frac{2(1 - a^2)}{1 + a^2 - 2a\cos w} \\
H(z)H(z^{-1}) &= \frac{2(1 - a^2)}{1 + a^2 - a(z + z^{-1})}
\end{aligned}$$

$$H(z)H(z^{-1}) = \frac{2(1+a)(1-a)}{(1-az^{-1})(1-az)}$$

$$\text{Hence, } H(z) = \frac{\sqrt{2(1-a^2)}}{1-az^{-1}}$$

$$\text{or } H(z) = \frac{\sqrt{2(1-a^2)}}{1-az}$$

4.105

$$\begin{aligned} H(z) &= (1 - 0.8e^{j\pi/2}z^{-1})(1 - 0.8e^{-j\pi/2}z^{-1})(1 - 1.5e^{j\pi/4}z^{-1})(1 - 1.5e^{-j\pi/4}z^{-1}) \\ &= (1 + 0.64z^{-2})(1 - \frac{3}{\sqrt{2}}z^{-1} + 2.25z^{-2}) \end{aligned}$$

(a) There are four different FIR systems with real coefficients:

$$H_1(z) = (1 + 0.64z^{-2})(1 - \frac{3}{\sqrt{2}}z^{-1} + 2.25z^{-2})$$

$$H_2(z) = (1 + 0.64z^{-2})(1 - \frac{3}{\sqrt{2}}z^{-1} + 2.25z^{-2})$$

$$H_3(z) = (1 + 0.64z^{-2})(1 - \frac{3}{\sqrt{2}}z^{-1} + 2.25z^{-2})$$

$$H_4(z) = (1 + 0.64z^{-2})(1 - \frac{3}{\sqrt{2}}z^{-1} + 2.25z^{-2})$$

$H(z)$ is the minimum-phase system.

(b)

$$H_1(z) = 1 - \frac{3}{\sqrt{2}}z^{-1} + 2.89z^{-2} - \frac{1.92}{\sqrt{2}}z^{-3} + 1.44z^{-4}$$

$$h_1(n) = \left\{ 1, -\frac{3}{\sqrt{2}}, 2.89, \frac{-1.92}{\sqrt{2}}, 1.44 \right\}$$

$$H_2(z) = 0.64z^2 - \frac{1.92}{\sqrt{2}}z + 2.44 - \frac{3}{\sqrt{2}}z^{-1} + 2.25z^{-2}$$

$$h_2(n) = \left\{ 0.64, \frac{-1.92}{\sqrt{2}}, 2.44, -\frac{3}{\sqrt{2}}, 2.25 \right\}$$

$$H_3(z) = 2.25z^2 - \frac{3}{\sqrt{2}}z + 2.44 - \frac{1.92}{\sqrt{2}}z^{-1} + 0.64z^{-2}$$

$$h_3(n) = \left\{ 2.25, \frac{-3}{\sqrt{2}}, 2.44, -\frac{1.92}{\sqrt{2}}, 0.64 \right\}$$

$$H_4(z) = 1.44z^4 - \frac{1.92}{\sqrt{2}}z^3 + 2.89z^2 - \frac{3}{\sqrt{2}}z + 1$$

$$h_4(n) = \left\{ 1.44, \frac{-1.92}{\sqrt{2}}, 2.89, -\frac{3}{\sqrt{2}}, 1 \right\}$$

(c)

$$E_1(n) = \{1, 5.5, 13.85, 15.70, 17.77\}$$

$$E_2(n) = \{0.64, 2.48, 8.44, 12.94, 18.0\}$$

$$E_3(n) = \{2.25, 6.75, 12.70, 14.55, 14.96\}$$

$$E_4(n) = \{1.44, 3.28, 11.64, 16.14, 17.14\}$$

Clearly, $h_3(n)$ is minimum phase and $h_2(n)$ is maximum phase.

4.106

$$H(z) = \frac{1}{1 + \sum_{k=1}^N a_k z^{-k}}$$

(a) The new system function is $H'(z) = H(\lambda^{-1}z)$

$$H'(z) = \frac{1}{1 + \sum_{k=1}^N a_k \lambda^k z^{-k}}$$

If p_k is a pole of $H(z)$, then λp_k is a pole of $H'(z)$.
Hence, $\lambda < \frac{1}{|p_{max}|}$ is selected then $|\lambda p_k| < 1$ for all k and, hence the system is stable.

(b) $y(n) = -\sum_{k=1}^N a_k \lambda^k y(n-k) = x(n)$

4.107

(a) The impulse response is given in pr10fig 4.76.

(b) Reverberator 1: refer to fig 4.77.

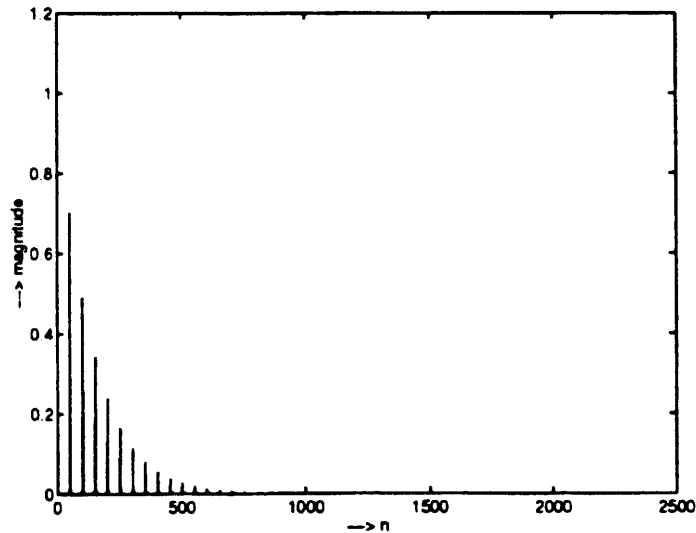

Figure 4.76:

Reverberator 2: refer to fig 4.77.

(c) Unit 2 is a better reverberator.

(d) For prime number of D_1, D_2, D_3 , the reverberations of the signal in the different sections do not overlap which results in the impulse response of the unit being more dense.

(e) Refer to fig 4.78.

(f) Refer to fig 4.79 for the delays being prime numbers.

4.108

(a) Refer to fig 4.80.

(b) Refer to fig 4.81.

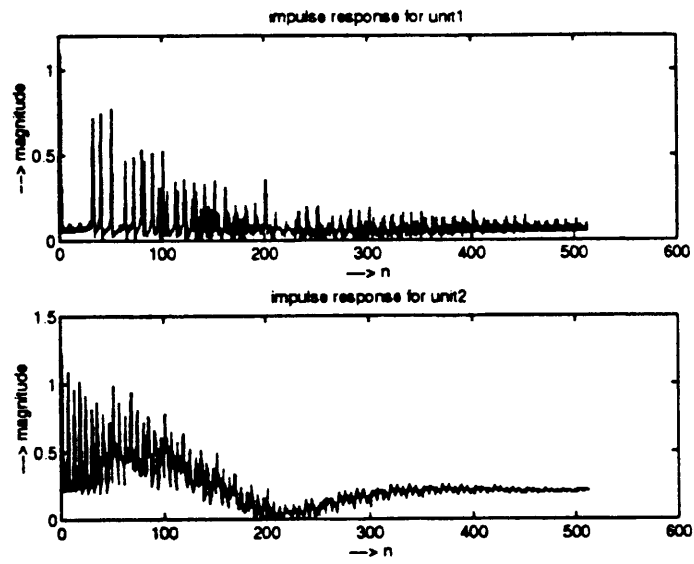

Figure 4.77:

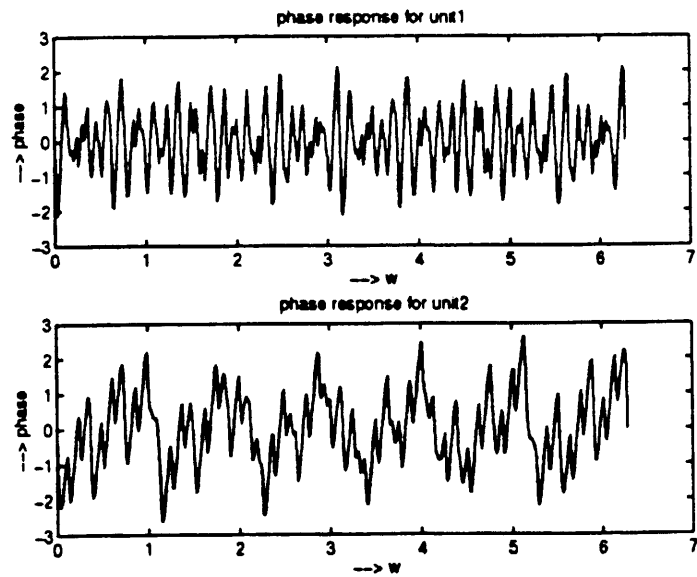

Figure 4.78:

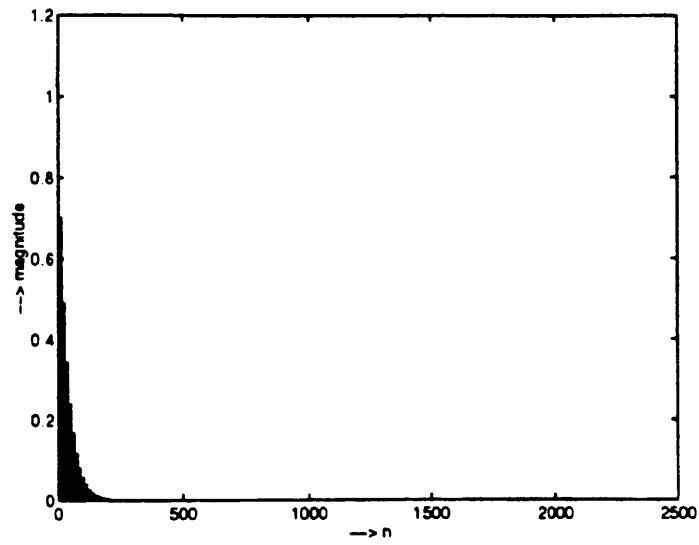

Figure 4.79:

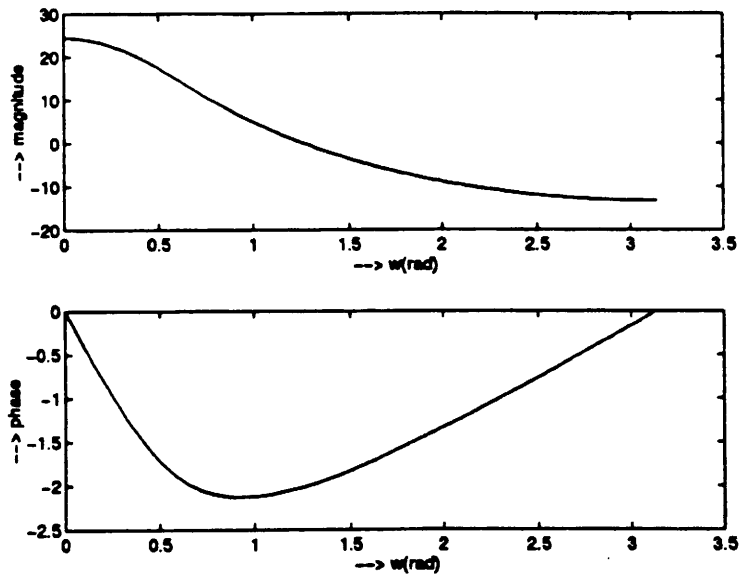

Figure 4.80:

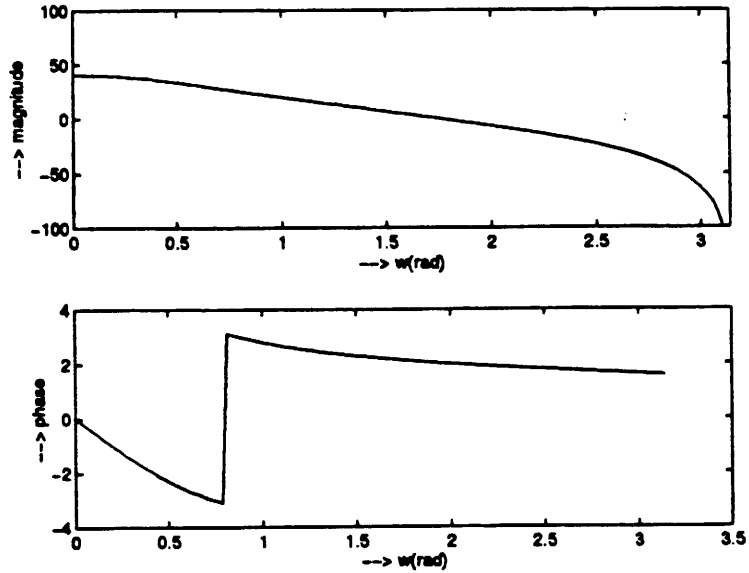

Figure 4.81:

4.109

(a)

$$\begin{aligned}
 B &= 10kH z \\
 F_s &= 20kH z \\
 z_1 &= \frac{10k}{20k} = 0.5 \\
 z_2 &= \frac{7.778k}{20k} = 0.3889 \\
 z_3 &= \frac{8.889k}{20k} = 0.4445 \\
 z_4 &= \frac{6.667k}{20k} = 0.3334 \\
 H(z) &= (z - 0.5)(z - 0.3889)(z - 0.4445)(z - 0.3334)
 \end{aligned}$$

(b) Refer to fig 4.82.

(c) It satisfies the objectives but this filter is not recommended in a practical application because in a speech application linear phase for the filter is desired and this filter does not provide linear phase for all frequencies.

4.110

Refer to fig 4.83.

Practical:

$$\begin{aligned}
 r = 0.99 \quad w_r = \frac{\pi}{6} \quad \text{Bandwidth} &= \frac{\pi}{128} = 0.0245 \\
 r = 0.9 \quad w_r = \frac{\pi}{6} \quad \text{Bandwidth} &= \frac{5\pi}{32} = 0.49 \\
 r = 0.6 \quad w_r = 0 \quad \text{Bandwidth} &= 1.1536
 \end{aligned}$$

Theoretical:

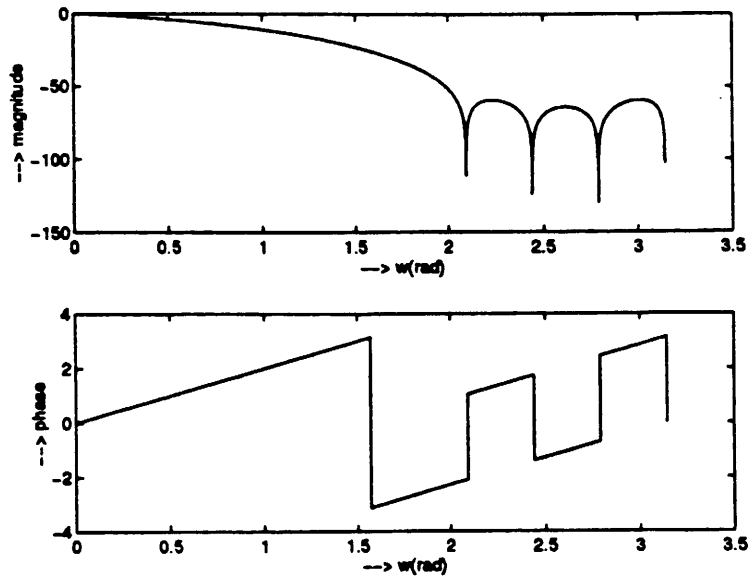

Figure 4.82:

$$\begin{aligned}
 r = 0.99, \quad w_r = \frac{\pi}{6} \quad \text{Bandwidth} = 2(1 - r) = 0.02 \\
 r = 0.9, \quad w_r = \frac{\pi}{6} \quad \text{Bandwidth} = 2(1 - r) = 0.2
 \end{aligned}$$

For r very close to 1, the theoretical and practical values match.

4.111

$$\begin{aligned}
 H(z) &= (1 - 0.9e^{j0.4\pi}z^{-1})(1 - 0.9e^{-j0.4\pi}z^{-1})(1 - 1.5e^{j0.6\pi}z^{-1})(1 - 1.5e^{-j0.6\pi}z^{-1}) \\
 H(z) &= \frac{B(z)}{A(z)} \\
 &= \frac{(z - 0.9e^{j0.4\pi})(z - 0.9e^{-j0.4\pi})(z - 1.5e^{j0.6\pi})(z - 1.5e^{-j0.6\pi})}{z^4} \\
 \text{Let } B_1(z) &= (z - 0.9e^{j0.4\pi})(z - 0.9e^{-j0.4\pi}) \\
 B_2(z) &= (z - 1.5e^{j0.6\pi})(z - 1.5e^{-j0.6\pi}) \\
 A(z) &= z^4 \\
 H_{\min}(z) &= \frac{B_1(z) B_2(z)}{A(z)} \\
 &= \frac{(z - 0.9e^{j0.4\pi})(z - 0.9e^{-j0.4\pi})(z^{-1} - 1.5e^{j0.6\pi})(z^{-1} - 1.5e^{-j0.6\pi})}{z^4} \\
 H_{\text{ap}}(z) &= \frac{B_2(z)}{B_2(z^{-1})} \\
 &= \frac{(z - 1.5e^{j0.6\pi})(z - 1.5e^{-j0.6\pi})}{(z^{-1} - 1.5e^{j0.6\pi})(z^{-1} - 1.5e^{-j0.6\pi})}
 \end{aligned}$$

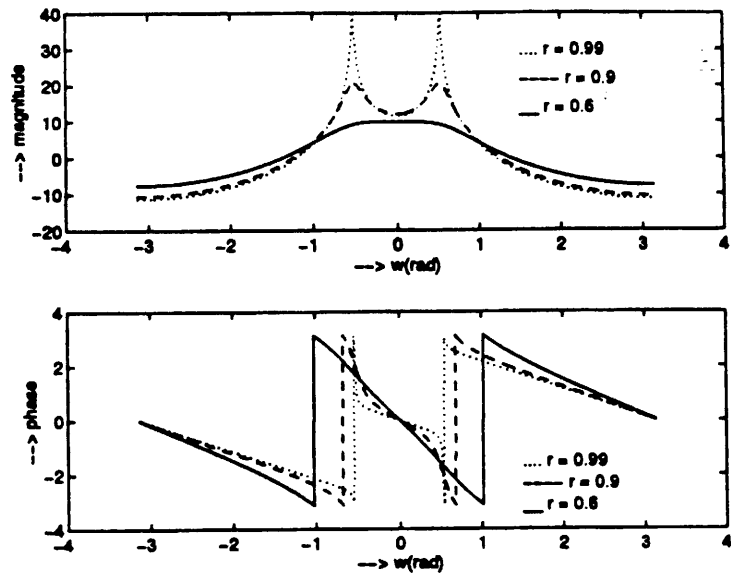

Figure 4.83:

$H_{ap}(z)$ has a flat magnitude response. To get a flat magnitude response for the system, connect a system which is the inverse of $H_{\min}(z)$, i.e.,

$$\begin{aligned}
 H_c(z) &= \frac{1}{H_{\min}(z)} \\
 &= \frac{z^4}{(z - 0.9e^{j0.4\pi})(z - 0.9e^{-j0.4\pi})(z^{-1} - 1.5e^{j0.6\pi})(z^{-1} - 1.5e^{-j0.6\pi})}
 \end{aligned}$$

(b) Refer to fig 4.84 and fig 4.85.

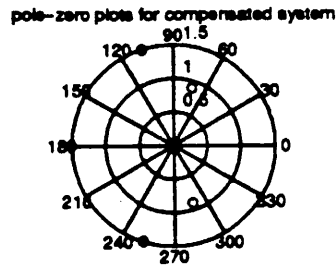
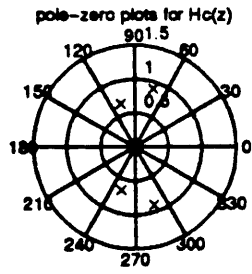

Figure 4.84:

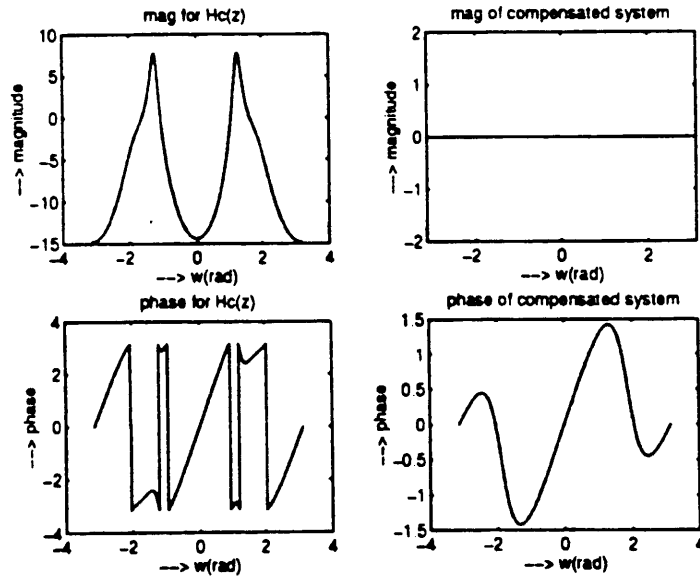

Figure 4.85:

Chapter 5

5.1

Since $x(n)$ is real, the real part of the DFT is even, imaginary part odd. Thus, the remaining points are $\{0.125 + j0.0518, 0, 0.125 + j0.3018\}$

5.2

(a)

$$\begin{aligned}\tilde{x}_2(l) &= x_2(l), & 0 \leq l \leq N-1 \\ &= x_2(l+N), & -(N-1) \leq l \leq -1 \\ \tilde{x}_2(l) &= \sin\left(\frac{3\pi}{8}l\right), & 0 \leq l \leq 7 \\ &= \sin\left(\frac{3\pi}{8}(l+8)\right), & -7 \leq l \leq -1 \\ &= \sin\left(\frac{3\pi}{8}|l|\right), & |l| \leq 7\end{aligned}$$

$$\begin{aligned}\text{Therefore, } x_1(n) \textcircled{8} x_2(n) &= \sum_{m=0}^3 \tilde{x}^2(n-m) \\ &= \sin\left(\frac{3\pi}{8}|n|\right) + \sin\left(\frac{3\pi}{8}|n-1|\right) + \dots + \sin\left(\frac{3\pi}{8}|n-3|\right) \\ &= \{1.25, 2.55, 2.55, 1.25, 0.25, -1.06, -1.06, 0.25\}\end{aligned}$$

(b)

$$\begin{aligned}\tilde{x}_2(n) &= \cos\left(\frac{3\pi}{8}n\right), & 0 \leq l \leq 7 \\ &= -\cos\left(\frac{3\pi}{8}n\right), & -7 \leq l \leq -1 \\ &= [2u(n) - 1] \cos\left(\frac{3\pi}{8}n\right), & |n| \leq 7\end{aligned}$$

$$\begin{aligned}\text{Therefore, } x_1(n) \textcircled{8} x_2(n) &= \sum_{m=0}^3 \left(\frac{1}{4}\right)^m \tilde{x}^2(n-m) \\ &= \{0.96, 0.62, -0.55, -1.06, -0.26, -0.86, 0.92, -0.15\}\end{aligned}$$

(c)

$$\text{for (a) } X_1(k) = \sum_{n=0}^7 x_1(n) e^{-j\frac{\pi}{4}kn}$$

$$= \{4, 1 - j2.4142, 0, 1 - j0.4142, 0, 1 + j0.4142, 0, 1 + j2.4142\}$$

similarly,

$$X_2(k) = \{1.4966, 2.8478, -2.4142, -0.8478, -0.6682, -0.8478, -2.4142, 2.8478\}$$

$$\begin{aligned} \text{DFT of } x_1(n) \otimes x_2(n) &= X_1(k)X_2(k) \\ &= \{5.9864, 2.8478 - j6.8751, 0, -0.8478 + j0.3512, 0, \\ &\quad -0.8478 - j0.3512, 0, 2.8478 + j6.8751\} \end{aligned}$$

For sequences of part (b)

$$X_1(k) = \{1.3333, 1.1612 - j0.2493, 0.9412 - j0.2353, 0.8310 - j0.1248, 0.8, 0.8310 + j0.1248, 0.9412 + j0.2353, 1.1612 + j0.2493\}$$

$$X_2(k) = \{1.0, 1.0 + j2.1796, 1.0 - j2.6131, 1.0 - j0.6488, 1.0, 1.0 + j0.6488, 1.0 + j2.6131, 1.0 - j2.1796\}$$

Consequently,

$$\begin{aligned} \text{DFT of } x_1(n) \otimes x_2(n) &= X_1(k)X_2(k) \\ &= \{1.3333, 1.7046 + j2.2815, 0.3263 - j2.6947, 0.75 - j0.664, 0.8, \\ &\quad 0.75 + j0.664, 0.3263 + j2.6947, 1.7046 - j2.2815\} \end{aligned}$$

5.3

$\hat{x}(k)$ may be viewed as the product of $X(k)$ with

$$F(k) = \begin{cases} 1, & 0 \leq k \leq k_c, N - k_c \leq k \leq N - 1 \\ 0, & K_c < k < N - k_c \end{cases}$$

$F(k)$ represents an ideal lowpass filter removing frequency components from $(K_c + 1)\frac{2\pi}{N}$ to π . Hence $\hat{x}(n)$ is a lowpass version of $x(n)$.

5.4

(a)

$$\begin{aligned} x_1(n) &= \frac{1}{2} \left(e^{j\frac{2\pi}{N}n} + e^{-j\frac{2\pi}{N}n} \right) \\ X_1(k) &= \frac{N}{2} [\delta(k-1) + \delta(k+1)] \\ \text{also } X_2(k) &= \frac{N}{2j} [\delta(k-1) - \delta(k+1)] \\ \text{So } X_3(k) &= X_1(k)X_2(k) \\ &= \frac{N^2}{4j} [\delta(k-1) - \delta(k+1)] \\ \text{and } x_3(n) &= \frac{N}{2} \sin\left(\frac{2\pi}{N}n\right) \end{aligned}$$

(b)

$$\begin{aligned} \bar{R}_{xy}(k) &= X_1(k)X_2^*(k) \\ &= \frac{N^2}{4j} [\delta(k-1) - \delta(k+1)] \\ \Rightarrow \bar{r}_{xy}(n) &= -\frac{N}{2} \sin\left(\frac{2\pi}{N}n\right) \end{aligned}$$

(c)

$$\begin{aligned}\tilde{R}_{xx}(k) &= X_1(k)X_1^*(k) \\ &= \frac{N^2}{4} [\delta(k-1) + \delta(k+1)] \\ \Rightarrow \tilde{r}_{xx}(n) &= \frac{N}{2} \cos\left(\frac{2\pi}{N}n\right)\end{aligned}$$

(d)

$$\begin{aligned}\tilde{R}_{yy}(k) &= X_2(k)X_2^*(k) \\ &= \frac{N^2}{4} [\delta(k-1) + \delta(k+1)] \\ \Rightarrow \tilde{r}_{yy}(n) &= \frac{N}{2} \cos\left(\frac{2\pi}{N}n\right)\end{aligned}$$

5.5

(a)

$$\begin{aligned}\sum_{n=0}^{N-1} x_1(n)x_2^*(n) &= \frac{1}{4} \sum_{n=0}^{N-1} \left(e^{j\frac{2\pi}{N}n} + e^{-j\frac{2\pi}{N}n} \right)^2 \\ &= \frac{1}{4} \sum_{n=0}^{N-1} \left(e^{j\frac{4\pi}{N}n} + e^{-j\frac{4\pi}{N}n} \right) \\ &= \frac{1}{4} 2N \\ &= \frac{N}{2}\end{aligned}$$

(b)

$$\begin{aligned}\sum_{n=0}^{N-1} x_1(n)x_2^*(n) &= -\frac{1}{4j} \sum_{n=0}^{N-1} \left(e^{j\frac{2\pi}{N}n} + e^{-j\frac{2\pi}{N}n} \right) \left(e^{-j\frac{2\pi}{N}n} - e^{j\frac{2\pi}{N}n} \right) \\ &= \frac{1}{4j} \sum_{n=0}^{N-1} \left(e^{j\frac{4\pi}{N}n} - e^{-j\frac{4\pi}{N}n} \right) \\ &= 0\end{aligned}$$

$$(c) \sum_{n=0}^{N-1} x_1(n)x_2^*(n) = 1 + 1 = 2$$

5.6

$$\begin{aligned}w(n) &= 0.42 - 0.25 \left(e^{j\frac{2\pi}{N-1}n} + e^{-j\frac{2\pi}{N-1}n} \right) + 0.04 \left(e^{j\frac{4\pi}{N-1}n} + e^{-j\frac{4\pi}{N-1}n} \right) \\ w(k) &= 0.42 \sum_{n=0}^{N-1} e^{-j\frac{2\pi}{N}nk} - 0.25 \left[\sum_{n=0}^{N-1} e^{j\frac{2\pi}{N-1}n} e^{-j\frac{2\pi}{N}nk} + \sum_{n=0}^{N-1} e^{-j\frac{2\pi}{N-1}n} e^{-j\frac{2\pi}{N}nk} \right] \\ &\quad + 0.04 \left[\sum_{n=0}^{N-1} e^{j\frac{4\pi}{N-1}n} e^{-j\frac{2\pi}{N}nk} + \sum_{n=0}^{N-1} e^{-j\frac{4\pi}{N-1}n} e^{-j\frac{2\pi}{N}nk} \right] \\ &= 0.42N\delta(k)\end{aligned}$$

$$\begin{aligned}
& -0.25 \left[\frac{1 - e^{j2\pi[\frac{N}{N-1}-k]}}{1 - e^{j2\pi[\frac{1}{N-1}-\frac{k}{N}]}} + \frac{1 - e^{-j2\pi[\frac{N}{N-1}+k]}}{1 - e^{-j2\pi[\frac{1}{N-1}+\frac{k}{N}]}} \right] \\
& + 0.04 \left[\frac{1 - e^{j2\pi[\frac{2N}{N-1}-k]}}{1 - e^{j2\pi[\frac{2}{N-1}-\frac{k}{N}]} + \frac{1 - e^{-j2\pi[\frac{2N}{N-1}+k]}}{1 - e^{-j2\pi[\frac{2}{N-1}+\frac{k}{N}]} \right] \\
= & 0.42N\delta(k) \\
& -0.25 \left[\frac{1 - \cos(\frac{2\pi N}{N-1}) - \cos(2\pi(\frac{1}{N-1} + \frac{k}{N})) + \cos(\frac{2\pi k}{N})}{1 - \cos(2\pi(\frac{1}{N-1} + \frac{k}{N}))} \right] \\
& + 0.04 \left[\frac{1 - \cos(\frac{4\pi N}{N-1}) - \cos(2\pi(\frac{2}{N-1} + \frac{k}{N})) + \cos(\frac{2\pi k}{N})}{1 - \cos(2\pi(\frac{2}{N-1} + \frac{k}{N}))} \right]
\end{aligned}$$

5.7

$$\begin{aligned}
X_c(k) &= \sum_{n=0}^{N-1} \frac{1}{2} x(n) \left(e^{j\frac{2\pi k_0 n}{N}} + e^{-j\frac{2\pi k_0 n}{N}} \right) e^{-\frac{2\pi k n}{N}} \\
&= \frac{1}{2} \sum_{n=0}^{N-1} x(n) e^{-j\frac{2\pi(k-k_0)n}{N}} + \frac{1}{2} \sum_{n=0}^{N-1} x(n) e^{-j\frac{2\pi(k+k_0)n}{N}} \\
&= \frac{1}{2} X(k-k_0)_{\text{mod } N} + \frac{1}{2} X(k+k_0)_{\text{mod } N} \\
\text{similarly, } X_s(k) &= \frac{1}{2j} X(k-k_0)_{\text{mod } N} - \frac{1}{2j} X(k+k_0)_{\text{mod } N}
\end{aligned}$$

5.8

$$\begin{aligned}
y(n) &= x_1(n)4x_2(n) \\
&= \sum_{m=0}^3 x_1(m)_{\text{mod } 4} x_2(n-m)_{\text{mod } 4} \\
&= \{17, 19, 22, 19\}
\end{aligned}$$

5.9

$$\begin{aligned}
X_1(k) &= \{7, -2-j, 1, -2+j\} \\
X_2(k) &= \{11, 2-j, 1, 2+j\} \\
\Rightarrow X_3(k) &= X_1(k)X_2(k) \\
&= \{17, 19, 22, 19\}
\end{aligned}$$

5.10

$$\begin{aligned}
x(n) &= \frac{1}{2} \left(e^{j\frac{2\pi k n}{N}} + e^{-j\frac{2\pi k n}{N}} \right) \\
x(n)x^*(n) &= \frac{1}{4} \left(2 + e^{j\frac{4\pi k n}{N}} + e^{-j\frac{4\pi k n}{N}} \right)
\end{aligned}$$

$$\begin{aligned}
E &= \sum_{n=0}^{N-1} x(n)x^*(n) \\
&= \frac{1}{4} \sum_{n=0}^{N-1} \left(2 + e^{j\frac{4\pi kn}{N}} + e^{-j\frac{4\pi kn}{N}} \right) \\
&= \frac{1}{4} 2N \\
&= \frac{N}{2}
\end{aligned}$$

5.11

(a)

$$\begin{aligned}
x_1(n) &= x(n-5)_{\text{mod } 8} \\
X_1(k) &= X(k)e^{-j\frac{2\pi 5k}{8}} \\
&= X(k)e^{-j\frac{5\pi k}{4}}
\end{aligned}$$

(b)

$$\begin{aligned}
x_2(n) &= x(n-2)_{\text{mod } 8} \\
X_2(k) &= X(k)e^{-j\frac{2\pi 2k}{8}} \\
&= X(k)e^{-j\frac{\pi k}{2}}
\end{aligned}$$

5.12

(a)

$$\begin{aligned}
s(k) &= W_2^k X(k) \\
&= (-1)^k X(k) \\
s(n) &= \frac{1}{6} \sum_{k=0}^5 (-1)^k X(k) W_N^{-kn} \quad N=6 \\
&= \frac{1}{6} \sum_{k=0}^5 X(k) W_N^{-k(n-3)} \\
&= x(n-3)_{\text{mod } 6} \\
s(n) &= \{3, 4, 0, 0, 1, 2\}
\end{aligned}$$

(b)

$$\begin{aligned}
y(n) &= \text{IDFT} \left\{ \frac{X(k) + X^*(k)}{2} \right\} \\
&= \frac{1}{2} [\text{IDFT} \{X(k)\} + \text{IDFT} \{X^*(k)\}] \\
&= \frac{1}{2} [x(n) + x^*(-n)_{\text{mod } N}] \\
&= \left\{ x(0), \frac{x(1) + x(5)}{2}, \frac{x(2) + x(4)}{2}, x(3), \frac{x(4) + x(2)}{2}, \frac{x(5) + x(1)}{2} \right\} \\
&= \left\{ 0, \frac{1}{2}, 3, 3, 3, \frac{1}{2} \right\}
\end{aligned}$$

(c)

$$v(n) = \text{IDFT} \left\{ \frac{X(k) - X^*(k)}{2j} \right\}$$

By similar means to (b)

$$v(n) = \left\{ 0, -\frac{1}{2}j, j, 0, -j, \frac{1}{2}j \right\}$$

5.13

(a)

$$\begin{aligned} X_1(k) &= \sum_{n=0}^{N-1} x(n)W_N^{kn} \\ X_3(k) &= \sum_{n=0}^{3N-1} x(n)W_{3N}^{kn} \\ &= \sum_{n=0}^{N-1} x(n)W_{3N}^{kn} + \sum_{n=N}^{2N-1} x(n)W_{3N}^{kn} + \sum_{n=2N}^{3N-1} x(n)W_{3N}^{kn} \\ &= \sum_{n=0}^{N-1} x(n)W_N^{n\frac{k}{3}} + \sum_{n=0}^{N-1} x(n)W_3^k W_N^{n\frac{k}{3}} + \sum_{n=0}^{N-1} x(n)W_3^{2k} W_N^{n\frac{k}{3}} \\ &= \sum_{n=0}^{N-1} x(n) [1 + W_3^k + W_3^{2k}] W_N^{n\frac{k}{3}} \\ &= (1 + W_3^k + W_3^{2k})X_1(k) \end{aligned}$$

(b)

$$\begin{aligned} X_1(k) &= 2 + W_2^k \\ X_3(k) &= 2 + W_6^k + 2W_6^{2k} + W_6^{3k} + 2W_6^{4k} + W_6^{5k} \\ &= (2 + W_2^{\frac{k}{3}}) + W_6^{2k}(2 + W_2^{\frac{k}{3}}) + W_6^{4k}(2 + W_2^{\frac{k}{3}}) \\ &= (1 + W_3^k + W_3^{2k})X_1\left(\frac{k}{3}\right) \end{aligned}$$

5.14

(a)

$$\begin{aligned} y(n) &= x_1(n) \textcircled{5} x_2(n) \\ &= \{4, 0, 1, 2, 3\} \end{aligned}$$

(b) Let $x_3(n) = \{x_0, x_1, \dots, x_4\}$. Then,

$$\begin{bmatrix} 0 & 4 & 3 & 2 & 1 \\ 1 & 0 & 4 & 3 & 2 \\ 2 & 1 & 0 & 4 & 3 \\ 3 & 2 & 1 & 0 & 4 \\ 4 & 3 & 2 & 1 & 0 \end{bmatrix} \begin{bmatrix} x_0 \\ x_1 \\ x_2 \\ x_3 \\ x_4 \end{bmatrix} = \begin{bmatrix} 1 \\ 0 \\ 0 \\ 0 \\ 0 \end{bmatrix}$$

Solving yields sequence $x_3(n) = \{-0.187, 0.22, 0.02, 0.02, 0.02\}$.

5.15

Define $H_1(z) \triangleq H^{-1}(z)$ and corresponding time signal $h_1(n)$. The use of 64-pt DFTs of $y(n)$ and $h_1(n)$ yields $x(n) = y(n) \circledast h_1(n)$ whereas $x(n)$ requires linear convolution. However we can simply recognize that

$$\begin{aligned} X(z) &= Y(z)H_1(z) \\ &= Y(z) - 0.5Y(z)z^{-1} \\ \text{so } x(n) &= y(n) - 0.5y(n-1), \quad 0 \leq n \leq 63 \\ \text{with } y(-1) &\triangleq 0 \end{aligned}$$

5.16

$$\begin{aligned} H(k) &= \sum_{n=0}^{N-1} h(n)e^{-j\frac{2\pi}{N}kn} \\ &= 1 + \left(\frac{1}{4}\right)e^{-j\frac{2\pi}{4k_0}k_0k} \\ &= 1 - \frac{1}{4}e^{-j\frac{\pi}{2}k} \\ G(k) &= \frac{1}{H(k)} \\ &= \frac{1}{1 - \frac{1}{4}e^{-j\frac{\pi}{2}k}} \\ &= 1 + \left(\frac{1}{4}e^{-j\frac{\pi}{2}k}\right) + \left(\frac{1}{4}e^{-j\frac{\pi}{2}k}\right)^2 + \dots \\ &= \left\{ \frac{4}{3}, \frac{16-4j}{17}, \frac{4}{5}, \frac{16+4j}{17}, \text{ repeat } k_0 \text{ times} \right\} \\ g(n) &= \frac{1}{N} \sum_{n=0}^{N-1} G(k)e^{j\frac{2\pi}{N}kn} \\ &= \frac{1}{4k_0} \left\{ \sum_{k=0,4,\dots}^{4k_0-4} \frac{4}{3} e^{j\frac{2\pi}{4k_0}kn} + \sum_{k=1,5,\dots}^{4k_0-3} \left(\frac{16-4j}{17}\right) e^{j\frac{2\pi}{4k_0}kn} \right. \\ &\quad \left. + \sum_{k=2,6,\dots}^{4k_0-2} \frac{4}{5} e^{j\frac{2\pi}{4k_0}kn} + \sum_{k=3,7,\dots}^{4k_0-1} \left(\frac{16+4j}{17}\right) e^{j\frac{2\pi}{4k_0}kn} \right\} \\ &= \frac{1}{4k_0} \left[\left\{ \frac{4}{3} \sum \right\} + \left\{ \left(\frac{16-4j}{17}\right) e^{j\frac{2\pi}{4k_0}n} \sum \right\} + \left\{ \frac{4}{5} e^{j\frac{2\pi}{4k_0}2n} \sum \right\} \right. \\ &\quad \left. + \left\{ \left(\frac{16+4j}{17}\right) e^{j\frac{2\pi}{4k_0}3n} \sum \right\} \right] \\ \text{where } \sum &\triangleq \sum_{i=0}^{k_0-1} e^{j\frac{2\pi}{k_0}ni} \\ \text{But } \sum &= 1, \text{ yielding} \\ g(0) &= \frac{1}{4} \left[\frac{4}{3} + \left(\frac{16-4j}{17}\right) + \frac{4}{5} + \left(\frac{16+4j}{17}\right) \right] \\ &= \frac{256}{255} \end{aligned}$$

$$\begin{aligned}
g(k_0) &= \frac{1}{4} \left[\frac{4}{3} + j \left(\frac{16-4j}{17} \right) - \frac{4}{5} - j \left(\frac{16+4j}{17} \right) \right] \\
&= \frac{64}{255} \\
g(2k_0) &= \frac{1}{4} \left[\frac{4}{3} - \left(\frac{16-4j}{17} \right) + \frac{4}{5} - \left(\frac{16+4j}{17} \right) \right] \\
&= \frac{16}{255} \\
g(3k_0) &= \frac{1}{4} \left[\frac{4}{3} - j \left(\frac{16-4j}{17} \right) - \frac{4}{5} + j \left(\frac{16+4j}{17} \right) \right] \\
&= \frac{4}{255} \\
\text{and } g(n) &= 0 \text{ for other } n \text{ in } [0, 4k_0].
\end{aligned}$$

$$\text{Therefore, } g(n) * h(n) = \left\{ \begin{array}{cccccccc} \frac{256}{255}, & 0, & 0, & \dots, & 0, & \dots, & 0, & \dots, & 0, & \dots, & -\frac{1}{255}, & 0 \end{array} \right\}$$

\uparrow
 k_0
 \uparrow
 $2k_0$
 \uparrow
 $3k_0$
 \uparrow
 $4k_0$

$g(\cdot)$ represents a close approximation to an inverse system, but not an exact one.

5.17

$$\begin{aligned}
X(k) &= \sum_{n=0}^7 x(n) e^{-j \frac{2\pi}{8} kn} \\
&= \{6, -0.7071 - j1.7071, 1 - j, 0.7071 + j0.2929, 0, 0.7071 - j0.2929, 1 + j, \\
&\quad -0.7071 + j1.7071\} \\
|X(k)| &= \{6, 1.8478, 1.4142, 0.7654, 0, 0.7654, 1.4142, 1.8478\} \\
\angle X(k) &= \left\{ 0, -1.9635, \frac{-\pi}{4}, 0.3927, 0, -0.3927, \frac{\pi}{4}, 1.9635 \right\}
\end{aligned}$$

5.18

$$\begin{aligned}
x(n) &= \sum_{i=-\infty}^{\infty} \delta(n - iN) \\
y(n) &= \sum_m h(m) x(n - m) \\
&= \sum_m h(m) \left[\sum_i \delta(n - m - iN) \right] \\
&= \sum_i h(n - iN)
\end{aligned}$$

Therefore, $y(\cdot)$ is a periodic sequence with period N . So

$$\begin{aligned}
Y(k) &= \sum_{n=0}^{N-1} y(n) W_N^{kn} \\
&= H(w)|_{w = \frac{2\pi}{N}k}
\end{aligned}$$

$$Y(k) = H\left(\frac{2\pi k}{N}\right) \quad k = 0, 1, \dots, N-1$$

5.19

Call the two real even sequences $x_{e1}(\cdot)$ and $x_{e2}(\cdot)$, and the odd ones $x_{o1}(\cdot)$ and $x_{o2}(\cdot)$ (a)

$$\text{Let } x_c(n) = [x_{e1}(n) + x_{o1}(n)] + j[x_{e2}(n) + x_{o2}(n)]$$

$$\begin{aligned} \text{Then, } X_c(k) &= \text{DFT}\{x_{e1}(n)\} + \text{DFT}\{x_{o1}(n)\} + j\text{DFT}\{x_{e2}(n)\} + j\text{DFT}\{x_{o2}(n)\} \\ &= [X_{e1}(k) + X_{o1}(k)] + j[X_{e2}(k) + X_{o2}(k)] \end{aligned}$$

$$\text{where } X_{e1}(k) = \frac{\text{Re}[X_c(k)] + \text{Re}[X_c(-k)]}{2}$$

$$X_{o1}(k) = \frac{\text{Re}[X_c(k)] - \text{Re}[X_c(-k)]}{2}$$

$$X_{e2}(k) = \frac{\text{Im}[X_c(k)] + \text{Im}[X_c(-k)]}{2}$$

$$X_{o2}(k) = \frac{\text{Im}[X_c(k)] - \text{Im}[X_c(-k)]}{2}$$

(b)

$$\begin{aligned} s_i(0) &= x_i(1) - x_i(N-1) = 0 \\ -s_i(N-n) &= -x_i(N-n+1) + x_i(N-n-1) \\ &= x_i(n+1) - x_i(n-1) \\ &= s_i(n) \end{aligned}$$

(c)

$$x(n) = [x_1(n) + s_3(n)] + j[x_2(n) + s_4(n)]$$

The DFT of the four sequences can be computed using the results of part (a)

$$\begin{aligned} \text{For } i = 3, 4, s_i(k) &= \sum_{n=0}^{N-1} s_i(n) W_N^{kn} \\ &= \sum_{n=0}^{N-1} [x_i(n+1) - x_i(n-1)] W_N^{kn} \\ &= W_N^{-k} X_i(k) - W_N^k X_i(k) \\ &= 2j \sin\left(\frac{2\pi}{N}k\right) X_i(k) \end{aligned}$$

$$\text{Therefore, } X_3(k) = \frac{s_3(k)}{2j \sin\left(\frac{2\pi}{N}k\right)}$$

$$X_4(k) = \frac{s_4(k)}{2j \sin\left(\frac{2\pi}{N}k\right)}$$

(d) $X_3(0)$ and $X_4(0)$, because $\sin\left(\frac{2\pi}{N}k\right) = 0$.

5.20

$$X(k) = \sum_{n=0}^{N-1} x(n) W_N^{kn}$$

$$\begin{aligned}
&= \sum_{n=0}^{\frac{N}{2}-1} x(n)W_N^{kn} + \sum_{n=0}^{\frac{N}{2}-1} x(n + \frac{N}{2})W_N^{k(n+\frac{N}{2})} \\
&= \sum_{n=0}^{\frac{N}{2}-1} [x(n) - x(n)W_2^k] W_N^{kn}
\end{aligned}$$

If k is even, $W_2^k = 1$, and $X(k) = 0$

(b) If k is odd, $W_2^k = -1$, Therefore,

$$\begin{aligned}
X(k) &= \sum_{n=0}^{\frac{N}{2}-1} 2x(n)W_N^{kn} \\
&= 2 \sum_{n=0}^{\frac{N}{2}-1} x(n)W_{\frac{N}{2}}^{n\frac{k}{2}}
\end{aligned}$$

$$\text{For } k = 2l + 1, \quad l = 0, \dots, \frac{N}{2} - 1$$

$$\begin{aligned}
X(2l + 1) &= 2 \sum_{n=0}^{\frac{N}{2}-1} x(n)W_{\frac{N}{2}}^{ln} W_N^n \\
&= \frac{N}{2} - \text{pt DFT of sequence } 2x(n)W_N^n
\end{aligned}$$

5.21

(a) $F_s \equiv F_N = 2B = 6000$ samples/sec

(b)

$$\begin{aligned}
T &= \frac{1}{F_s} \\
&= \frac{1}{6000} \\
\frac{1}{LT} &\leq 50 \\
\Rightarrow L &\geq \frac{1}{50T} \\
&= \frac{6000}{50} \\
&= 120 \text{ samples}
\end{aligned}$$

(c) $LT = \frac{1}{6000} \times 120 = 0.02$ seconds.

5.22

$$x(n) = \frac{1}{2}e^{j\frac{2\pi}{10}n} + \frac{1}{2}e^{-j\frac{2\pi}{10}n}, \quad 0 \leq n \leq N, \quad N = 10$$

$$\begin{aligned}
X(k) &= \sum_{n=0}^{N-1} x(n)e^{-j\frac{2\pi}{10}kn} \\
&= \sum_{n=0}^{N-1} \frac{1}{2}e^{-j\frac{2\pi}{10}(k-1)n} + \sum_{n=0}^{N-1} \frac{1}{2}e^{-j\frac{2\pi}{10}(k+1)n} \\
&= 5\delta(k-1) + 5\delta(k-9), \quad 0 \leq k \leq 9
\end{aligned}$$

5.23

(a) $X(k) = \sum_{n=0}^{N-1} \delta(n) e^{-j \frac{2\pi}{N} kn} = 1, \quad 0 \leq k \leq N-1$

(b)

$$\begin{aligned} X(k) &= \sum_{n=0}^{N-1} \delta(n - n_0) e^{-j \frac{2\pi}{N} kn} \\ &= e^{-j \frac{2\pi}{N} kn_0}, \quad 0 \leq k \leq N-1 \end{aligned}$$

(c)

$$\begin{aligned} X(k) &= \sum_{n=0}^{N-1} a^n e^{-j \frac{2\pi}{N} kn} \\ &= \sum_{n=0}^{N-1} (ae^{-j \frac{2\pi}{N} k})^n \\ &= \frac{1 - a^N}{1 - ae^{-j \frac{2\pi}{N} k}} \end{aligned}$$

(d)

$$\begin{aligned} X(k) &= \sum_{n=0}^{\frac{N}{2}-1} e^{-j \frac{2\pi}{N} kn} \\ &= \frac{1 - e^{-j \frac{2\pi}{N} \frac{N}{2} k}}{1 - e^{-j \frac{2\pi}{N} k}} \\ &= \frac{1 - (-1)^k}{1 - e^{-j \frac{2\pi}{N} k}} \end{aligned}$$

(e)

$$\begin{aligned} X(k) &= \sum_{n=0}^{N-1} e^{j \frac{2\pi}{N} nk_0} e^{-j \frac{2\pi}{N} kn} \\ &= \sum_{n=0}^{N-1} e^{-j \frac{2\pi}{N} (k - k_0)n} \\ &= N \delta(k - k_0) \end{aligned}$$

(f)

$$x(n) = \frac{1}{2} e^{j \frac{2\pi}{N} nk_0} + \frac{1}{2} e^{-j \frac{2\pi}{N} nk_0}$$

From (e) we obtain $X(k) = \frac{N}{2} [\delta(k - k_0) + \delta(k - N + k_0)]$

(g)

$$x(n) = \frac{1}{2j} e^{j \frac{2\pi}{N} nk_0} - \frac{1}{2j} e^{-j \frac{2\pi}{N} nk_0}$$

Hence $X(k) = \frac{N}{2j} [\delta(k - k_0) - \delta(k - N + k_0)]$

(h)

$$\begin{aligned} X(k) &= \sum_{n=0}^{N-1} x(n)e^{-j\frac{2\pi}{N}nk} \quad (\text{assume } N \text{ odd}) \\ &= 1 + e^{-j\frac{2\pi}{N}2k} + e^{-j\frac{2\pi}{N}4k} + \dots + e^{-j\frac{2\pi}{N}(N-1)k} \\ &= \frac{1 - (e^{-j\frac{2\pi}{N}2k})^{\frac{N+1}{2}}}{1 - e^{-j\frac{2\pi}{N}2k}} \\ &= \frac{1 - e^{-j\frac{2\pi}{N}k}}{1 - e^{-j\frac{2\pi}{N}k}} \\ &= \frac{1}{1 - e^{-j\frac{2\pi}{N}k}} \end{aligned}$$

5.24

(a)

$$x(n) = \frac{1}{N} \sum_{k=0}^{N-1} X(k)e^{j\frac{2\pi}{N}nk}$$

$$\Rightarrow \sum_{k=0}^{N-1} X(k)e^{j\frac{2\pi}{N}nk} = Nx(n)$$

$$X(0) + X(1) + X(2) + X(3) = 4$$

$$X(0) + X(1)e^{j\frac{\pi}{2}} + X(2)e^{j\pi} + X(3)e^{j\frac{3\pi}{2}} = 8$$

$$X(0) + X(1)e^{j\pi} + X(2)e^{j2\pi} + X(3)e^{j3\pi} = 12$$

$$X(0) + X(1)e^{j\frac{3\pi}{2}} + X(2)e^{j3\pi} + X(3)e^{j\frac{2\pi}{2}} = 4$$

$$\begin{bmatrix} 1 & 1 & 1 & 1 \\ 1 & j & -1 & -j \\ 1 & -1 & 1 & -1 \\ 1 & -j & -1 & j \end{bmatrix} \begin{bmatrix} X(0) \\ X(1) \\ X(2) \\ X(3) \end{bmatrix} = \begin{bmatrix} 4 \\ 8 \\ 12 \\ 4 \end{bmatrix} \Rightarrow \begin{bmatrix} X(0) \\ X(1) \\ X(2) \\ X(3) \end{bmatrix} = \begin{bmatrix} 7 \\ -2-j \\ 1 \\ -2+j \end{bmatrix}$$

(b)

$$X(k) = \sum_{n=0}^3 x(n)e^{-j\frac{2\pi}{4}nk}$$

$$\begin{aligned} X(0) &= \sum_{n=0}^3 x(n) \\ &= 7 \end{aligned}$$

$$\begin{aligned} X(1) &= \sum_{n=0}^3 x(n)e^{-j\frac{\pi}{2}n} \\ &= -2-j \end{aligned}$$

$$\begin{aligned} X(2) &= \sum_{n=0}^3 x(n)e^{-j\pi n} \\ &= 1 \end{aligned}$$

$$\begin{aligned} X(3) &= \sum_{n=0}^3 x(n)e^{-j\frac{3\pi}{2}n} \\ &= -2+j \end{aligned}$$

5.25

(a)

$$\begin{aligned} X(\omega) &= \sum_{n=-\infty}^{\infty} x(n)e^{-j\omega n} \\ &= e^{j2\omega} + 2e^{j\omega} + 3 + 2e^{-j\omega} + e^{-j2\omega} \\ &= 3 + 2\cos(2\omega) + 4\cos(4\omega) \end{aligned}$$

(b)

$$\begin{aligned} V(k) &= \sum_{n=0}^5 v(n)e^{-j\frac{2\pi}{6}nk} \\ &= 3 + 2e^{-j\frac{2\pi}{6}k} + e^{-j\frac{2\pi}{6}2k} + 0 + e^{-j\frac{2\pi}{6}4k} + e^{-j\frac{2\pi}{6}5k} \\ &= 3 + 4\cos\left(\frac{\pi}{3}k\right) + 2\cos\left(\frac{2\pi}{3}k\right) \end{aligned}$$

(c) $V(k) = X(\omega)|_{\omega=\frac{2\pi k}{6}=\frac{\pi k}{3}}$

This is apparent from the fact that $v(n)$ is one period ($0 \leq n \leq 7$) of a periodic sequence obtained by repeating $x(n)$.

5.26

$$\text{Let } x(n) = \sum_{l=-\infty}^{\infty} \delta(n + lN)$$

Hence, $x(n)$ is periodic with period N , i.e.

$$\begin{aligned} x(n) &= 1, \quad n = 0, \pm N, \pm 2N, \dots \\ &= 0, \quad \text{otherwise} \end{aligned}$$

$$\text{Then } X(k) = \sum_{n=0}^{N-1} x(n)e^{-j\frac{2\pi}{N}nk} = 1, \quad 0 \leq k \leq N-1$$

$$\text{and } x(n) = \frac{1}{N} \sum_{k=0}^{N-1} X(k)e^{j\frac{2\pi}{N}nk}$$

$$\text{Hence, } \sum_{l=-\infty}^{\infty} \delta(n + lN) = \frac{1}{N} \sum_{k=0}^{N-1} e^{j\frac{2\pi}{N}nk}$$

5.27

(a)

$$\begin{aligned} Y(k) &= \sum_{n=0}^{M-1} y(n)W_M^{kn} \\ &= \sum_{n=0}^{M-1} \sum_l x(n + lM)W_M^{kn} \\ \text{Now } X(\omega) &= \sum_n x(n)e^{-j\omega n}, \end{aligned}$$

$$\begin{aligned}
\text{so } X\left(\frac{2\pi}{M}k\right) &= \sum_n W_M^{kn} \\
&= \sum_{n=0}^{M-1} \sum_l x(n+lM) W_M^{k(n+lM)} \\
&= \sum_{n=0}^{M-1} \sum_l x(n+lM) W_M^{kn} \\
&= Y(k)
\end{aligned}$$

$$\text{Therefore, } Y(k) = X(w)|_{w=\frac{2\pi}{M}k}$$

(b)

$$Y(k) = X(w)|_{w=\frac{2\pi}{N}k}$$

$$\begin{aligned}
Y\left(\frac{k}{2}\right) &= X(w)|_{w=\frac{2\pi}{N}k} \\
&= X(k), \quad k = 2, 4, \dots, N-2
\end{aligned}$$

(c)

$$\begin{aligned}
X_1(k) &= X(k+1) \\
\Rightarrow x_1(n) &= x(n)e^{-j\frac{2\pi}{N}n} \\
&= x(n)W_N^n
\end{aligned}$$

$$\begin{aligned}
\text{Let } y(n) &= x_1(n) + x_1\left(n + \frac{N}{2}\right), \quad 0 \leq n \leq N-1 \\
&= 0, \quad \text{elsewhere}
\end{aligned}$$

$$\begin{aligned}
\text{Then } X(k+1) &= X_1(k) \\
&= Y\left(\frac{k}{2}\right), \quad k = 0, 2, \dots, N-2
\end{aligned}$$

where $Y(k)$ is the $\frac{N}{2}$ -pt DFT of $y(n)$

5.28

(a) Refer to fit 5.1.

(b)

$$\begin{aligned}
\sum_{n=-\infty}^{\infty} x(n)e^{-j\omega n} &= \sum_{n=-\infty}^{\infty} a^{|n|}e^{-j\omega n} \\
&= a + \sum_{-L}^1 a^{-n}e^{-j\omega n} + \sum_1^L a^n e^{-j\omega n} \\
&= a + \sum_1^L a^n e^{j\omega n} + \sum_1^L a^n e^{-j\omega n} \\
&= a + 2 \sum_{n=1}^L a^n \cos(\omega n) \\
&= x(0) + 2 \sum_{n=1}^L x(n) \cos(\omega n)
\end{aligned}$$

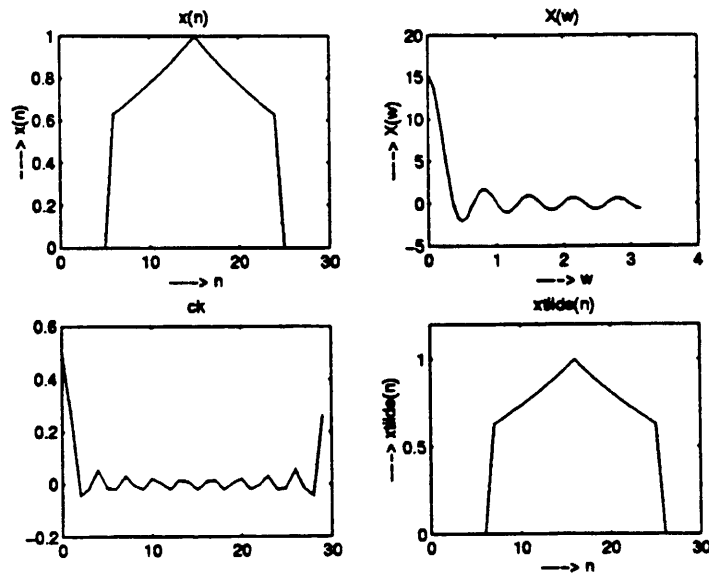

Figure 5.1:

- (c) Refer to fit 5.1.
- (d) Refer to fit 5.1.
- (e) Refer to fit 5.2.
- (f) $N=15$. Refer to fit 5.3.

5.29

Refer to fig 5.4. The time domain aliasing is clearly evident when $N=20$.

5.30

Refer to fig 5.5.

(e)

$$\begin{aligned}
 x_{am}(n) &= x(n)\cos(2\pi f_c n) \\
 X_{am}(w) &= \sum_{n=0}^{N-1} x(n)\cos(2\pi f_c n)e^{-j2\pi f n} \\
 &= \frac{1}{2} \sum_{n=0}^{N-1} x(n) \left[e^{-j2\pi(f-f_c)n} + e^{-j2\pi(f+f_c)n} \right] \\
 X_{am}(w) &= \frac{1}{2} [X(w-w_c) + X(w+w_c)]
 \end{aligned}$$

5.31

- (a) $c_k = \left\{ \frac{2}{\pi}, -\frac{1}{\pi}, \frac{2}{3\pi}, -\frac{1}{2\pi}, \dots \right\}$
- (b) Refer to fig 5.6. The DFT of $x(n)$ with $N = 128$ has a better resolution compared to one with $N = 64$.

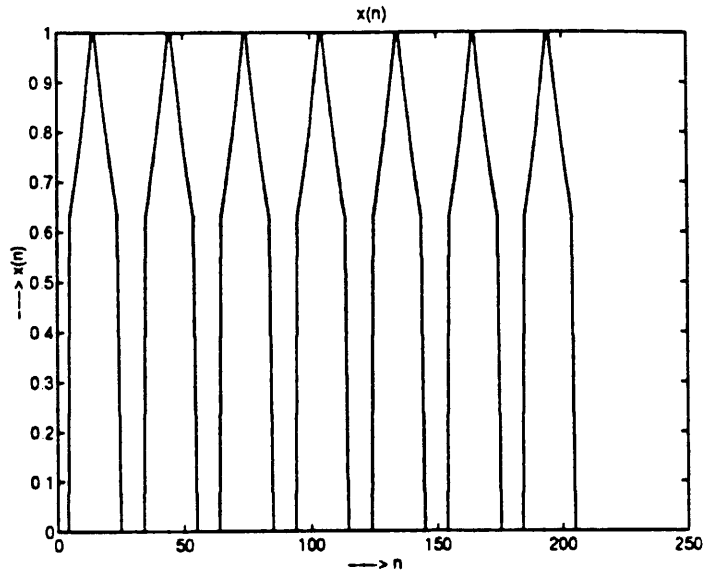

Figure 5.2:

5.32

(a)

$$\begin{aligned}
 Y(j\Omega) &= \frac{1}{2\pi} P(j\Omega) * X(j\Omega) \\
 &= \frac{1}{2\pi} \left(T_0 \operatorname{sinc}\left(\frac{\Omega T_0}{2}\right) e^{-j\frac{\Omega T_0}{2}} \right) * [2\pi \delta(\Omega - \Omega_0)] \\
 \text{where } \operatorname{sinc} x &\triangleq \frac{\sin x}{x} \\
 Y(j\Omega) &= T_0 \operatorname{sinc}\left(\frac{T_0(\Omega - \Omega_0)}{2}\right) e^{-j\frac{T_0(\Omega - \Omega_0)}{2}}
 \end{aligned}$$

(b) $\omega_0 P = 2\pi k$ for an integer k , or $\omega_0 = \frac{2k}{P} \pi$

(c)

$$\begin{aligned}
 Y(\omega) &= \sum_{n=0}^{N-1} e^{j\omega_0 n} e^{-j\omega n} \\
 &= \frac{\sin \frac{N}{2}(\omega - \omega_0)}{\sin \frac{\omega - \omega_0}{2}} e^{-j\frac{N-1}{2}(\omega - \omega_0)}
 \end{aligned}$$

Larger $N \Rightarrow$ narrower main lobe of $|Y(\omega)|$. T_0 in $Y(j\Omega)$ has the same effect.

(d)

$$\begin{aligned}
 Y(k) &= Y(\omega)|_{\omega = \frac{2\pi}{P}k} \\
 &= \frac{\sin \pi(k-l)}{\sin \frac{\pi(k-l)}{N}} e^{-j\frac{N-1}{N}\pi(k-l)} \\
 |Y(k)| &= \frac{|\sin \pi(k-l)|}{\left| \sin \frac{\pi(k-l)}{N} \right|} \\
 &= N \delta(k-l)
 \end{aligned}$$

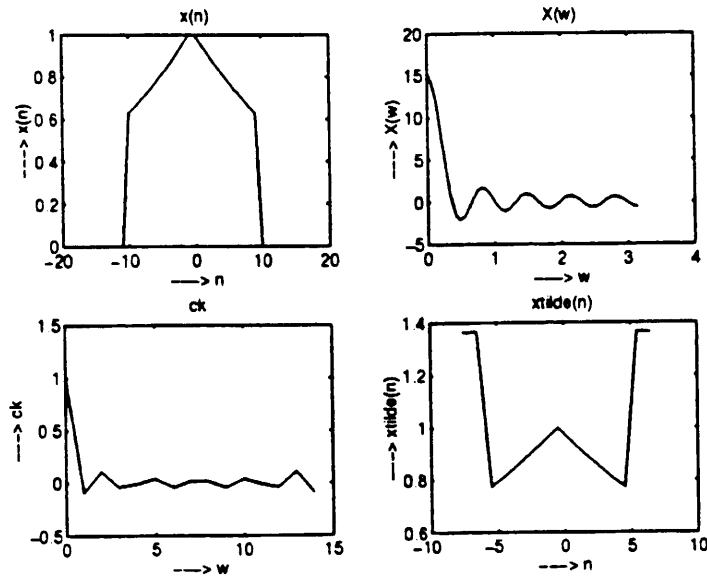

Figure 5.3:

(e) The frequency samples $\frac{2\pi}{N}k$ fall on the zeros of $Y(w)$. By increasing the sampling by a factor of two, for example, we will obtain a frequency sample between the nulls.

$$Y(w)|_{w=\frac{2\pi}{2N}k} = \frac{2\pi}{2N}k, \quad k=0,1,\dots,2N-1$$

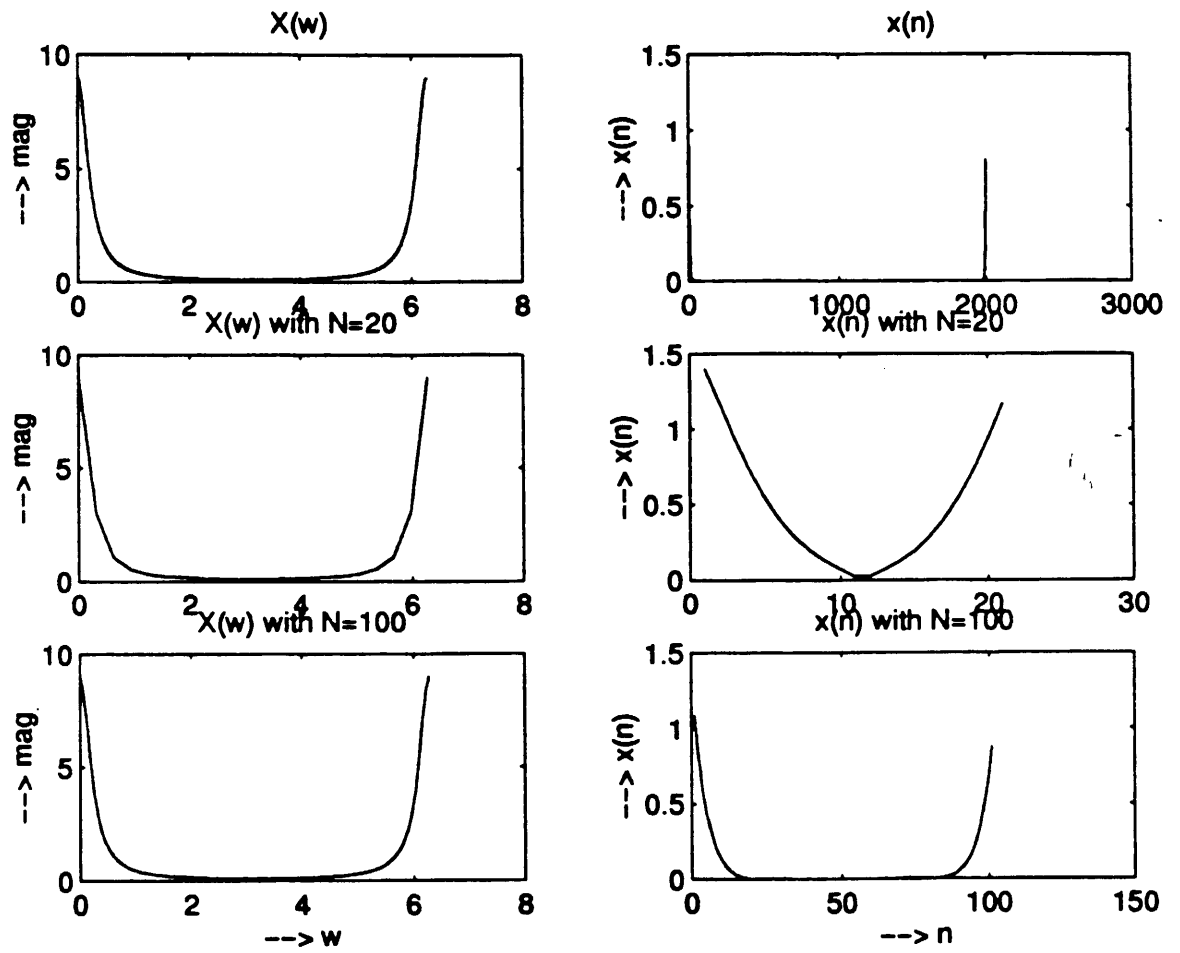

Figure 5.4:

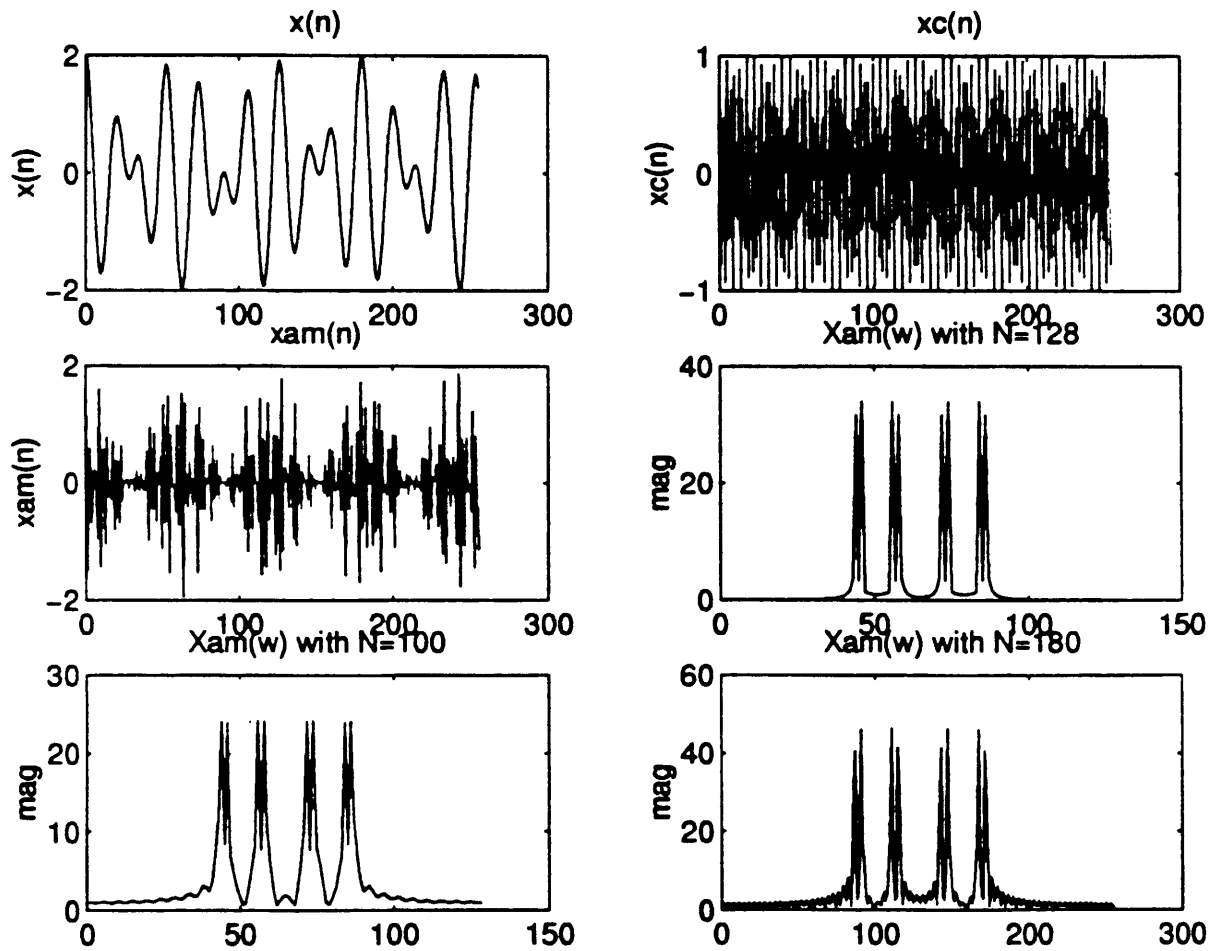

Figure 5.5:

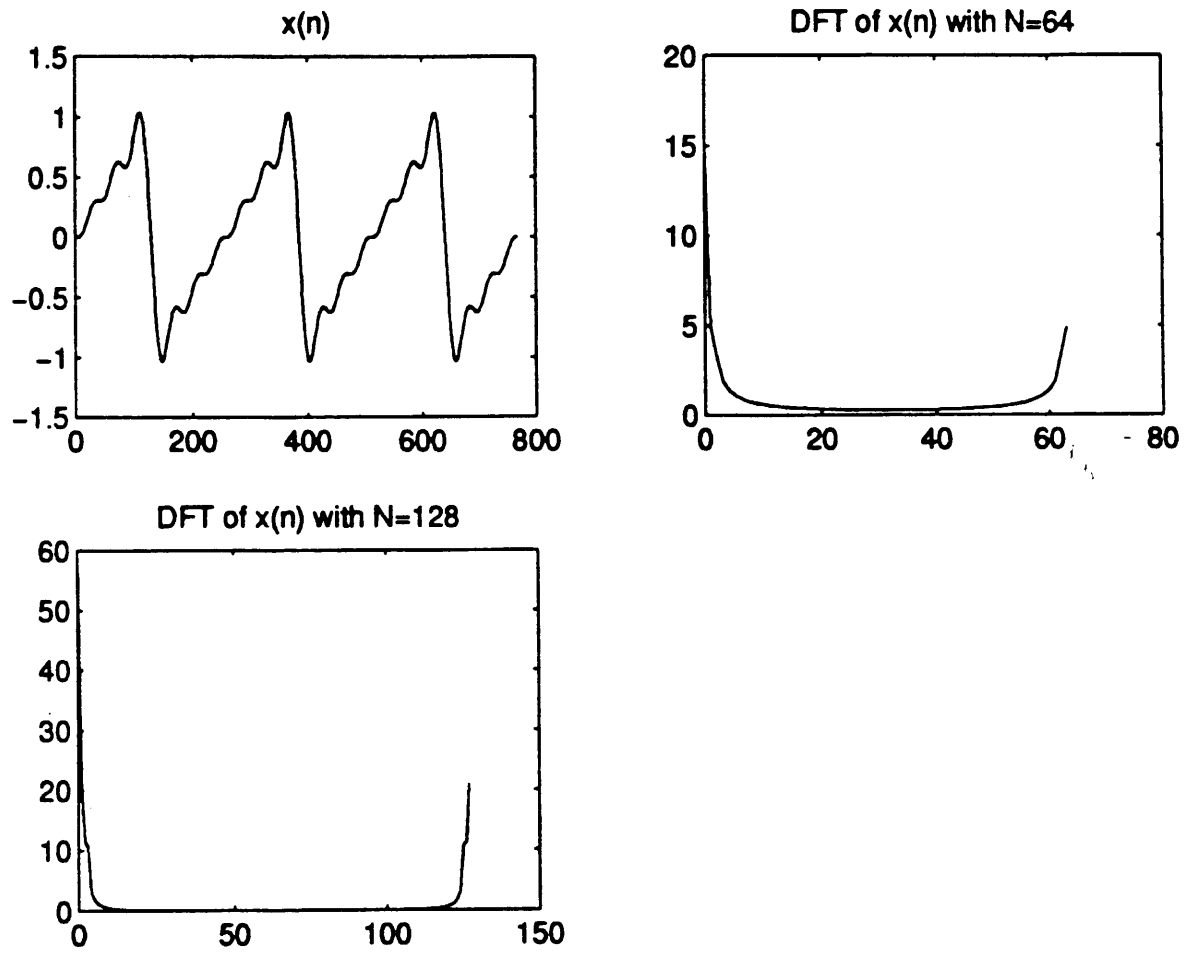
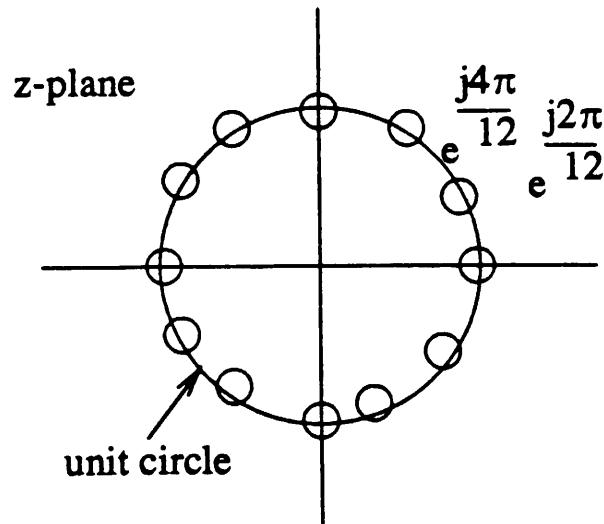

Figure 5.6:

Chapter 6

6.1

Since $(e^{j\frac{2\pi}{N}k})^N = e^{j2\pi k} = 1$, $e^{j\frac{2\pi}{N}k}$ satisfies the equation $X^N = 1$. Hence $e^{j\frac{2\pi}{N}k}$ is an N^{th} root of unity. Consider $\sum_{n=0}^{N-1} e^{j\frac{2\pi}{N}kn} e^{j\frac{2\pi}{N}ln}$. If $k \neq l$, the terms in the sum represent the N equally spaced roots in the unit circle which clearly add to zero. However, if $k = l$, the sum becomes $\sum_{n=0}^{N-1} 1 = N$. see fig 6.1



Roots for N=12

Figure 6.1:

6.2

(a) $W_N^q W_N^{q(l-1)} = e^{-j\frac{2\pi}{N}q} e^{-j\frac{2\pi}{N}q(l-1)} = e^{-j\frac{2\pi}{N}ql} = W_N^{ql}$

(b) Let $\hat{W}_N^q = W_N^q + \delta$ where \hat{W}_N^q is the truncated value of W_N^q . Now $\hat{W}_N^{ql} = (W_N^q + \delta)^l \approx W_N^{ql} + l\delta$.

Generally, single precision means a 32-bit length or $\delta = 5 \times 10^{-10}$; while 4 significant digits means $\delta = 5 \times 10^{-5}$. Thus the error in the final results would be 10^5 times larger.

(c) Since the error grows as $l\delta$, after N iterations we have an error of $N\delta$. If W_N^{ql} is reset to $-j$ after every $ql = \frac{N}{4}$ iterations, the error at the last step of the iteration is $l\delta = \left[\frac{N}{4q}\right]\delta$. Thus, the error reduced by approximately a factor $4q$.

6.3

$$\begin{aligned} X(k) &= \sum_{n=0}^{N-1} x(n)W_N^{kn} \quad 0 \leq k \leq N-1 \\ &= \sum_{n=0}^{\frac{N}{2}-1} x(n)W_N^{kn} + \sum_{n=\frac{N}{2}}^{N-1} x(n)W_N^{kn} \\ &= \sum_{n=0}^{\frac{N}{2}-1} x(n)W_N^{kn} + \sum_{r=0}^{\frac{N}{2}-1} x\left(r + \frac{N}{2}\right)W_N^{(r+\frac{N}{2})k} \end{aligned}$$

$$\text{Let } X'(k') = X(2k+1), \quad 0 \leq k' \leq \frac{N}{2} - 1$$

$$\text{Then, } X'(k') = \sum_{n=0}^{\frac{N}{2}-1} \left[x(n)W_N^{(2k'+1)n} + x\left(n + \frac{N}{2}\right)W_N^{(n+\frac{N}{2})(2k'+1)} \right]$$

$$\text{Using the fact that } W_N^{2k'n} = W_{\frac{N}{2}}^{k'n}, \quad W_N^N = 1$$

$$\begin{aligned} X'(k') &= \sum_{n=0}^{\frac{N}{2}-1} \left[x(n)W_N^n W_{\frac{N}{2}}^{k'n} + x\left(n + \frac{N}{2}\right)W_{\frac{N}{2}}^{k'n} W_N^n W_N^{\frac{N}{2}} \right] \\ &= \sum_{n=0}^{\frac{N}{2}-1} \left[x(n) - x\left(n + \frac{N}{2}\right) \right] W_N^n W_{\frac{N}{2}}^{k'n} \end{aligned}$$

6.4

Create three subsequences of 8-pts each

$$\begin{aligned} Y(k) &= \sum_{n=0,3,6,\dots}^{21} y(n)W_N^{kn} + \sum_{n=1,4,7,\dots}^{22} y(n)W_N^{kn} + \sum_{n=2,5,\dots}^{23} y(n)W_N^{kn} \\ &= \sum_{i=0}^7 y(3i)W_{\frac{N}{3}}^{ki} + \sum_{i=0}^7 y(3i+1)W_{\frac{N}{3}}^{ki}W_N^k + \sum_{i=0}^7 y(3i+2)W_{\frac{N}{3}}^{ki}W_N^{2k} \\ &\triangleq Y_1(k) + W_N^k Y_2(k) + W_N^{2k} Y_3(k) \end{aligned}$$

where Y_1, Y_2, Y_3 represent the 8-pt DFTs of the subsequences.

6.5

$$\begin{aligned} X(z) &= 1 + z^{-1} + \dots + z^{-6} \\ X(k) &= X(z)|_{z=e^{j\frac{2\pi}{3}k}} \end{aligned}$$

$$\begin{aligned}
&= 1 + e^{-j\frac{2\pi}{5}} + e^{-j\frac{4\pi}{5}} + \dots + e^{-j\frac{12\pi}{5}} \\
&= 2 + 2e^{-j\frac{2\pi}{5}} + e^{-j\frac{4\pi}{5}} + \dots + e^{-j\frac{8\pi}{5}} \\
x'(n) &= \{2, 2, 1, 1, 1\} \\
x'(n) &= \sum_m x(n + 7m), \quad n = 0, 1, \dots, 4
\end{aligned}$$

Temporal aliasing occurs in first two points of $x'(n)$ because $X(z)$ is not sampled at sufficiently small spacing on the unit circle.

6.6

- (a) $Z_k = 0.8e^{j[\frac{2\pi k}{8} + \frac{\pi}{8}]}$ see fig 6.2
(b)

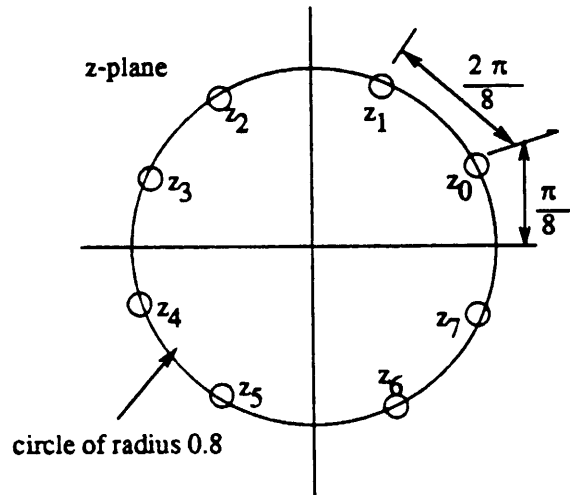

Figure 6.2:

$$\begin{aligned}
X(k) &= X(z)|_{z=z_k} \\
&= \sum_{n=0}^7 x(n) \left[0.8e^{j[\frac{2\pi k}{8} + \frac{\pi}{8}]} \right]^{-n} \\
s(n) &= x(n) 0.8e^{-j\frac{\pi}{8}n}
\end{aligned}$$

6.7

$$\text{Let } M = \frac{N}{2}, \quad L = 2. \text{ Then}$$

$$F(0, q) = \sum_{n=0}^{\frac{N}{2}-1} x(0, m) W_N^{mq}$$

$$F(1, q) = \sum_{n=0}^{\frac{N}{2}-1} x(1, m) W_N^{mq}$$

which are the same as $F_1(k)$ and $F_2(k)$ in (6.1.26)

$$G(0, q) = F(0, q) = F_1(k)$$

$$G(1, q) = W_N^q F(1, q) = F_2(k) W_N^k$$

$$X(0, q) = x(k) = G(0, q) + G(1, q) W_2^0$$

$$= F_1(k) + F_2(k) W_N^k$$

$$X(1, q) = x(k) = G(0, q) + G(1, q) W_2^1$$

$$= F_1(k) - F_2(k) W_N^k$$

6.8

$$W_8 = \frac{1}{\sqrt{2}}(1 - j)$$

Refer to Fig. 6.9. The first stage of butterflies produces (2, 2, 2, 2, 0, 0, 0, 0). The twiddle factor multiplications do not change this sequence. The next stage produces (4, 4, 0, 0, 0, 0, 0, 0) which again remains unchanged by the twiddle factors. The last stage produces (8, 0, 0, 0, 0, 0, 0, 0). The bit reversal to permute the sequence into proper order unscrambles only zeros so the result remains (8, 0, 0, 0, 0, 0, 0, 0).

6.9

See Fig. 6.13.

6.10

Using (6.1.45), (6.1.46), and (6.1.47) the fig 6.3 is derived:

6.11

Using DIT following fig 6.6:

$$\begin{aligned} \text{1st stage outputs} &: \left\{ \frac{1}{2}, \frac{1}{2}, \frac{1}{2}, \dots, \frac{1}{2} \right\} \\ \text{2nd stage outputs} &: \left\{ 1, \frac{1}{2}(1 + W_8^2), 0, \frac{1}{2}(1 - W_8^2), 1, \frac{1}{2}(1 + W_8^2), 0, \frac{1}{2}(1 - W_8^2) \right\} \\ \text{3rd stage outputs} &: \left\{ 2, \frac{1}{2}(1 + W_8^1 + W_8^2 + W_8^3), 0, \frac{1}{2}(1 - W_8^2 + W_8^3 - W_8^5), 0, \right. \\ &\quad \left. \frac{1}{2}(1 - W_8^1 + W_8^2 - W_8^3), 0, \frac{1}{2}(1 - W_8^2 - W_8^3 + W_8^5) \right\} \end{aligned}$$

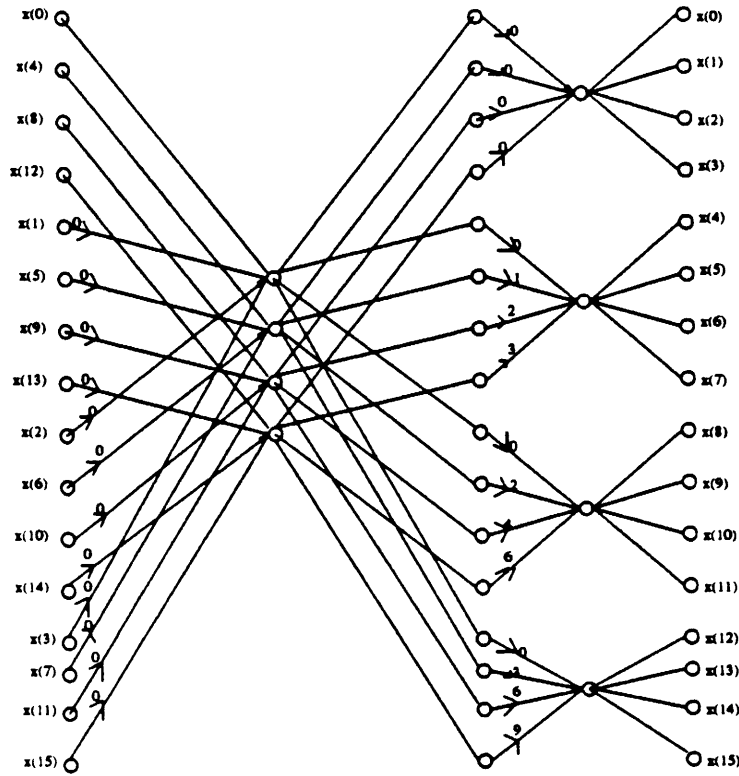

Figure 6.3:

Using DIF following fig 6.11:

$$1^{\text{st}} \text{ stage outputs} : \left\{ \frac{1}{2}, \frac{1}{2}, \frac{1}{2}, \frac{1}{2}, \frac{1}{2}, \frac{1}{2}, \frac{1}{2}, \frac{1}{2}, \frac{1}{2} W_8^1, \frac{1}{2} W_8^2, \frac{1}{2} W_8^3 \right\}$$

$$2^{\text{nd}} \text{ stage outputs} : \left\{ 1, 1, 0, 0, \frac{1}{2}(1 + W_8^2), 0, \frac{1}{2}(W_8^1 + W_8^3), \frac{1}{2}(1 - W_8^2), \frac{1}{2}(W_8^3 - W_8^5) \right\}$$

$$3^{\text{rd}} \text{ stage outputs} : \left\{ 2, 0, 0, 0, \frac{1}{2}(1 + W_8^1 + W_8^2 + W_8^3), \frac{1}{2}(1 - W_8^1 + W_8^2 - W_8^3), \right. \\ \left. \frac{1}{2}(1 - W_8^2 + W_8^3 - W_8^5), \frac{1}{2}(1 - W_8^2 - W_8^3 + W_8^5) \right\}$$

6.12

Let

$$A \triangleq \begin{bmatrix} 1 & 1 & 1 & 1 \\ 1 & -j & -1 & j \\ 1 & -1 & 1 & -1 \\ 1 & j & -1 & -j \end{bmatrix}$$

$$\underline{x}_1 \triangleq [x(0) \quad x(4) \quad x(8) \quad x(12)]^T$$

$$\underline{x}_2 \triangleq [x(1) \quad x(5) \quad x(9) \quad x(13)]^T$$

$$\underline{x}_3 \triangleq [x(2) \quad x(6) \quad x(10) \quad x(14)]^T$$

$$\underline{x}_4 \triangleq [x(3) \ x(7) \ x(11) \ x(15)]^T$$

$$\begin{bmatrix} F(0) \\ F(4) \\ F(8) \\ F(12) \end{bmatrix} = \underline{Ax}_1 = \begin{bmatrix} 4 \\ 0 \\ 0 \\ 0 \end{bmatrix}$$

$$\begin{bmatrix} F(1) \\ F(5) \\ F(9) \\ F(13) \end{bmatrix} = \underline{Ax}_2 = \begin{bmatrix} 0 \\ 0 \\ 0 \\ 0 \end{bmatrix}$$

$$\begin{bmatrix} F(2) \\ F(6) \\ F(10) \\ F(14) \end{bmatrix} = \underline{Ax}_3 = \begin{bmatrix} -4 \\ 0 \\ 0 \\ 0 \end{bmatrix}$$

$$\begin{bmatrix} F(3) \\ F(7) \\ F(11) \\ F(15) \end{bmatrix} = \underline{Ax}_4 = \begin{bmatrix} 0 \\ 0 \\ 0 \\ 0 \end{bmatrix}$$

As every $F(i) = 0$ except $F(0) = -F(2) = 4$,

$$\begin{bmatrix} x(0) \\ x(7) \\ x(8) \\ x(12) \end{bmatrix} = \underline{Ax}_4 \begin{bmatrix} F(0) \\ F(1) \\ F(2) \\ F(3) \end{bmatrix} = \begin{bmatrix} 0 \\ 8 \\ 0 \\ 8 \end{bmatrix}$$

which means that $X(4) = X(12) = 8$. $X(k) = 0$ for other K .

6.13

(a) "gain" = $W_8^0 W_8^0 (-1) W_8^2 = -W_8^2 = j$

(b) Given a certain output sample, there is one path from every input leading to it. This is true for every output.

(c) $X(3) = x(0) + W_8^3 x(1) - W_8^2 x(2) + W_8^2 W_8^3 x(3) - W_8^0 x(4) - W_8^0 W_8^3 x(5) + W_8^0 W_8^2 x(6) + W_8^0 W_8^2 W_8^3 x(7)$

6.14

Flowgraph for DIF SRFFT algorithm for $N=16$ is given in fig 6.4. There are 20 real, non trivial multiplications.

6.15

For the DIT FFT, we have

$$X(k) = \sum_{n=0}^{\frac{N}{2}-1} x(2n) W_N^{nk} + \sum_{n=0}^{\frac{N}{2}-1} x(2n+1) W_N^{(2n+1)k}$$

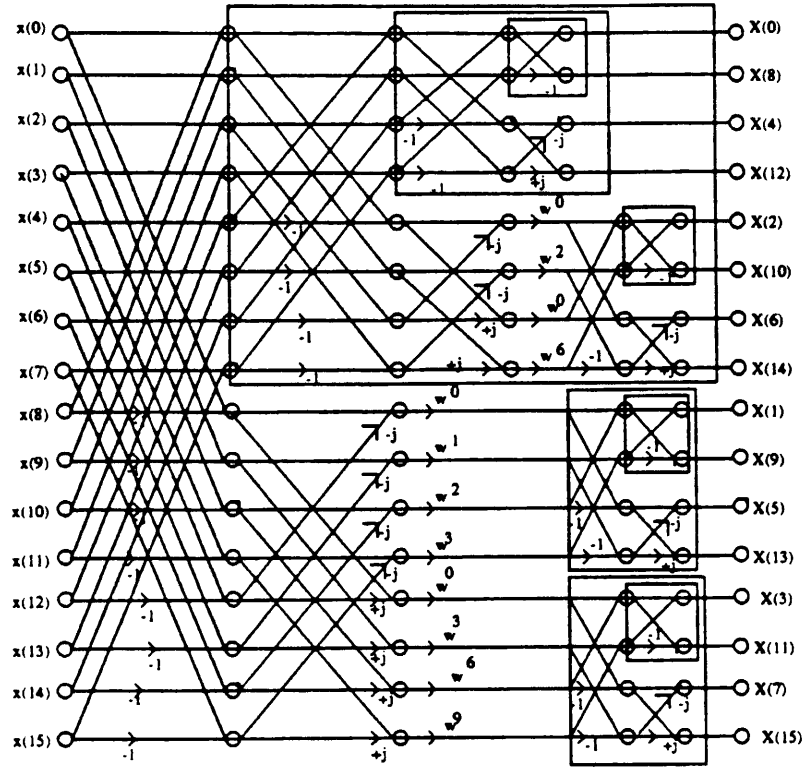

Figure 6.4:

The first term can be obtained from an $\frac{N}{2}$ -point DFT without any additional multiplications. Hence, we use a radix-2 FFT. For the second term, we use a radix-4 FFT. Thus, for $N=8$, the DFT is decomposed into a 4-point, radix-2 DFT and a 4-point radix-4 DFT. The latter is

$$\sum_{n=0}^{\frac{N}{2}-1} x(2n+1)W_N^{(2n+1)k} = \sum_{n=0}^{\frac{N}{4}-1} x(4n+1)W_N^k W_{\frac{N}{4}}^k + \sum_{n=0}^{\frac{N}{4}-1} x(4n+3)W_N^{3k} W_{\frac{N}{4}}^k$$

The computation of $X(k)$, $X(k + \frac{N}{4})$, $X(k + \frac{N}{2})$, $X(k + \frac{3N}{4})$ for $k = 0, 1, \dots, \frac{N}{4} - 1$ are performed from the following:

$$\begin{aligned} X(k) &= \sum_{n=0}^{\frac{N}{2}-1} x(2n)W_{\frac{N}{2}}^{nk} + \sum_{n=0}^{\frac{N}{4}-1} x(4n+1)W_N^k W_{\frac{N}{4}}^{nk} + \sum_{n=0}^{\frac{N}{4}-1} x(4n+3)W_N^{3k} W_{\frac{N}{4}}^{nk} \\ X(k + \frac{N}{4}) &= \sum_{n=0}^{\frac{N}{2}-1} x(2n)W_{\frac{N}{2}}^{nk} (-1)^n + \sum_{n=0}^{\frac{N}{4}-1} x(4n+1)(-j)W_N^k W_{\frac{N}{4}}^{nk} + \sum_{n=0}^{\frac{N}{4}-1} x(4n+3)W_N^{3k} (j)W_{\frac{N}{4}}^{nk} \\ X(k + \frac{N}{2}) &= \sum_{n=0}^{\frac{N}{2}-1} x(2n)W_{\frac{N}{2}}^{nk} + \sum_{n=0}^{\frac{N}{4}-1} x(4n+1)(-1)W_N^k W_{\frac{N}{4}}^{nk} + \sum_{n=0}^{\frac{N}{4}-1} x(4n+3)(-1)W_N^{3k} W_{\frac{N}{4}}^{nk} \\ X(k + \frac{3N}{4}) &= \sum_{n=0}^{\frac{N}{2}-1} x(2n)W_{\frac{N}{2}}^{nk} (-1)^n + \sum_{n=0}^{\frac{N}{4}-1} x(4n+1)(j)W_N^k W_{\frac{N}{4}}^{nk} + \sum_{n=0}^{\frac{N}{4}-1} x(4n+3)(-j)W_N^{3k} W_{\frac{N}{4}}^{nk} \end{aligned}$$

The basic butterfly is given in fig 6.5

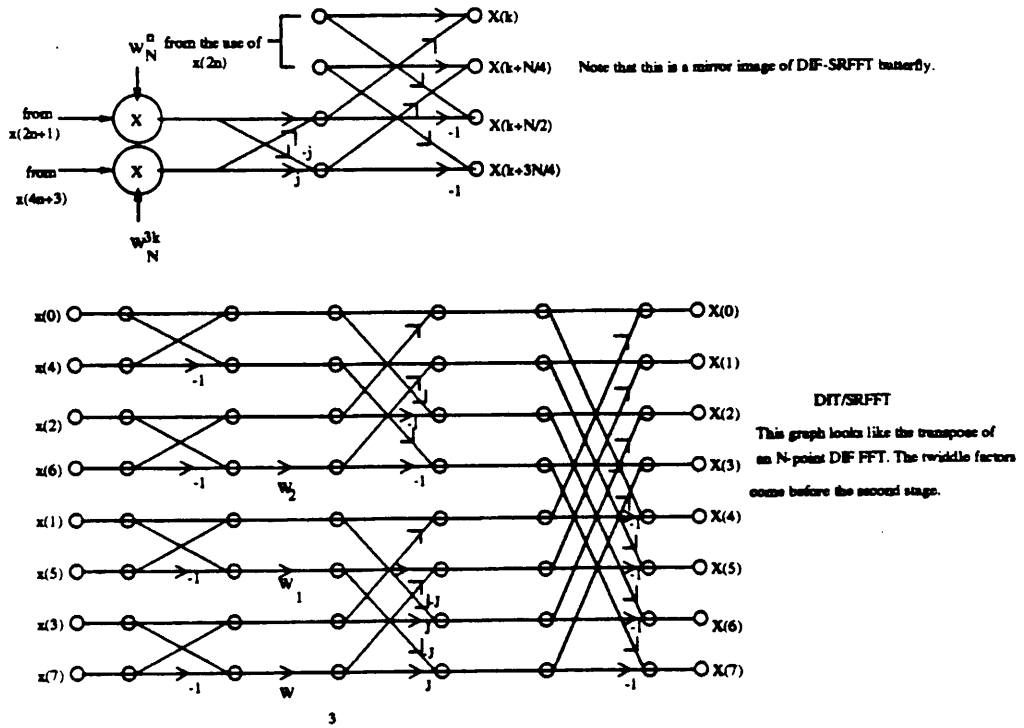

Figure 6.5:

6.16

$$\begin{aligned}
 x &= x_R + jx_I \\
 &= (a + jb)(c + jd) \\
 e &= (a - b)d \quad 1 \text{ add}, 1 \text{ mult} \\
 x_R &= e + (c - d)a \quad 2 \text{ adds}, 1 \text{ mult} \\
 x_I &= e + (c + d)b \quad 2 \text{ adds}, 1 \text{ mult} \\
 \text{Total} & \quad 5 \text{ adds}, 3 \text{ mult}
 \end{aligned}$$

6.17

$$\begin{aligned}
 X(z) &= \sum_{n=0}^{N-1} x(n)z^{-n} \\
 \text{Hence, } X(z_k) &= \sum_{n=0}^{N-1} x(n)r^{-n}e^{-j\frac{2\pi}{N}kn}
 \end{aligned}$$

where $z_k = re^{-j\frac{2\pi}{N}k}$, $k = 0, 1, \dots, N - 1$ are the N sample points. It is clear that $X(z_k)$, $k = 0, 1, \dots, N - 1$ is equivalent to the DFT (N -pt) of the sequence $x(n)r^{-n}$, $n \in [0, N - 1]$.

6.18

$$\begin{aligned}
 x'(n) &= \frac{1}{LN} \sum_{k=0}^{LN-1} X'(k) W_{LN}^{-kn} \\
 &= \frac{1}{LN} \left[\sum_{k=0}^{k_0-1} X'(k) W_{LN}^{-kn} + \sum_{k=LN-k_0+1}^{LN-1} X'(k) W_{LN}^{-kn} \right] \\
 &= \frac{1}{LN} \left[\sum_{k=0}^{k_0-1} X(k) W_{LN}^{-kn} + \sum_{k=LN-k_0+1}^{LN-1} X(k+N-LN) W_{LN}^{-kn} \right] \\
 &= \frac{1}{LN} \left[\sum_{k=0}^{k_0-1} X(k) W_{LN}^{-kn} + \sum_{k=N-k_0-1}^{N-1} X(k) W_{LN}^{-(k-N+LN)n} \right] \\
 \text{Therefore } Lx'(Ln) &= \frac{1}{N} \left[\sum_{k=0}^{k_0-1} X(k) W_N^{-kn} + \sum_{k=N-k_0+1}^{N-1} X(k) W_N^{-kn} \right] \\
 &= x(n)
 \end{aligned}$$

$L = 1$ is a trivial case with no zeros inserted and

$$x'(n) = x(n) = \left\{ \frac{1}{2}, \frac{1}{2} + j\frac{1}{2}, 0, \frac{1}{2} - j\frac{1}{2} \right\}$$

6.19

$$X(k) = \sum_{n=0}^{N-1} x(n) W_N^{kn}$$

Let $F(t)$, $t = 0, 1, \dots, N-1$ be the DFT of the sequence on $k X(k)$.

$$\begin{aligned}
 F(t) &= \sum_{k=0}^{N-1} X(k) W_N^{tk} \\
 &= \sum_{k=0}^{N-1} \left[\sum_{n=0}^{N-1} x(n) W_N^{kn} \right] W_N^{tk} \\
 &= \sum_{n=0}^{N-1} x(n) \left[\sum_{k=0}^{N-1} W_N^{k(n+t)} \right] \\
 &= \sum_{n=0}^{N-1} x(n) \delta(n+t)_{\text{mod } N} \\
 &= \sum_{n=0}^{N-1} x(n) \delta(N-1-n-t) \quad t = 0, 1, \dots, N-1 \\
 &= \{x(N-1), x(N-2), \dots, x(1), x(0)\}
 \end{aligned}$$

6.20

$$Y(k) = \sum_{n=0}^{2N-1} y(n) W_N^{kn} \quad k = 0, 1, \dots, 2N-1$$

$$\begin{aligned}
&= \sum_{n=0, n \text{ even}}^{2N-1} y(n) W_{2N}^{kn} \\
&= \sum_{m=0}^{N-1} y(2m) W_N^{km} \\
&= \sum_{m=0}^{N-1} x(m) W_N^{km} \\
&= X(k), \quad k \in [0, N-1] \\
&= X(k-N), \quad k \in [N, 2N-1]
\end{aligned}$$

6.21

(a)

$$\begin{aligned}
w(n) &= \frac{1}{2} \left(1 - \cos \frac{2\pi n}{N-1} \right), \quad 0 \leq n \leq N-1 \\
&= \frac{1}{2} - \frac{1}{4} \left(e^{j \frac{2\pi n}{N-1}} + e^{-j \frac{2\pi n}{N-1}} \right) \\
W(z) &= \sum_{n=0}^{N-1} w(n) z^{-n} \\
&= \sum_{n=0}^{N-1} \left[\frac{1}{2} - \frac{1}{4} \left(e^{j \frac{2\pi n}{N-1}} + e^{-j \frac{2\pi n}{N-1}} \right) \right] z^{-n} \\
&= \frac{1}{2} \frac{1-z^{-N}}{1-z^{-1}} - \frac{1}{4} \frac{1 - (z^{-1} e^{j \frac{2\pi}{N-1}})^N}{1 - z^{-1} e^{j \frac{2\pi}{N-1}}} \\
&\quad - \frac{1}{4} \frac{1 - (z^{-1} e^{-j \frac{2\pi}{N-1}})^N}{1 - z^{-1} e^{-j \frac{2\pi}{N-1}}}
\end{aligned}$$

(b)

$$\begin{aligned}
x_w(n) &= w(n)x(n) \\
\Rightarrow X_w(k) &= W(k)NX(k)
\end{aligned}$$

6.22

The standard DFT table stores N complex values W_N^k , $k = 0, 1, \dots, N-1$. However, since $W_N^{k+\frac{N}{2}} = -W_N^k$, we need only store W_N^k , $k = 0, 1, \dots, \frac{N}{2}-1$. Also, $W_N^{k+\frac{N}{4}} = -jW_N^k$ which is merely an interchange of real and imaginary parts of W_N^k and a sign reversal. Hence all essential quantities are easily obtained from W_N^k , $k = 0, 1, \dots, \frac{N}{4}-1$.

6.23

The radix-2 FFT algorithm for computing a $2N$ -pt DFT requires $\frac{2N}{N} \log_2 2N = N + N \log_2 N$ complex multiplications. The algorithm in (6.2.12) requires $2 \left[\frac{N}{2} \log_2 N + \frac{N}{2} \right] = \frac{N}{2} + \log_2 N$ complex multiplications.

6.24

$$\begin{aligned} \text{since } H(z) &= \frac{\sum_{k=0}^M b_k z^{-k}}{1 + \sum_{k=1}^N a_k z^{-k}} \\ H\left(\frac{2\pi}{N-1}k\right) &= \frac{\sum_{k=0}^M b_k W_{N+1}^{kn}}{1 + \sum_{k=1}^N a_k W_{N+1}^{kn}} \\ &\triangleq H(k), \quad k = 0, \dots, N \end{aligned}$$

Compute $N + 1$ -pt DFTs of sequences $\{b_0, b_1, \dots, b_M, 0, 0, \dots, 0\}$ and $\{1, a_1, \dots, a_N\}$ (assumes $N > M$), say $B(k)$ and $A(k)$ $k = 0, \dots, N$

$$H(k) = \frac{B(k)}{A(k)}$$

6.25

$$\begin{aligned} Y(k) &= \sum_{n=0}^8 y(n) W_9^{nk} \\ &= \sum_{n=0,3,6} y(n) W_9^{nk} + \sum_{n=1,4,7} y(n) W_9^{nk} + \sum_{n=2,5,8} y(n) W_9^{nk} \\ &= \sum_{m=0}^2 y(3m) W_9^{3km} + \sum_{m=0}^2 y(3m+1) W_9^{(3m+1)k} + \sum_{m=0}^2 y(3m+2) W_9^{(3m+2)k} \\ &= \sum_{m=0}^2 y(3m) W_3^{km} + \sum_{m=0}^2 y(3m+1) W_3^{mk} W_9^k + \sum_{m=0}^2 y(3m+2) W_3^{mk} W_9^{2k} \end{aligned}$$

Total number of complex multiplies is 28 and the operations can be performed in-place. see fig 6.6

6.26

$$\begin{aligned} X(k) &= \sum_{n=0}^8 x(n) W_9^{nk} \\ &= \sum_{n=0}^2 x(n) W_9^{kn} + \sum_{n=3}^5 x(n) W_9^{nk} + \sum_{n=6}^8 x(n) W_9^{nk} \\ &= \sum_{n=0}^2 x(n) W_9^{kn} + \sum_{n=0}^2 x(n+3) W_9^{nk} W_3^k + \sum_{n=0}^2 x(n+6) W_9^{nk} W_3^{2k} \\ x(3l) &= \sum_{n=0}^2 x(n) W_3^{nl} + \sum_{n=0}^2 x(n+3) W_3^{nl} + \sum_{n=0}^2 x(n+6) W_3^{nl} \\ x(3l+1) &= \sum_{n=0}^2 x(n) W_3^{nl} W_9^n + \sum_{n=0}^2 x(n+3) W_3^{nl} W_9^n W_3^1 + \sum_{n=0}^2 x(n+6) W_3^{nl} W_9^n W_3^2 \\ &= \sum_{n=0}^2 W_9^n [x(n) + W_3^1 x(n+3) + W_3^2 x(n+6)] W_3^{nl} \end{aligned}$$

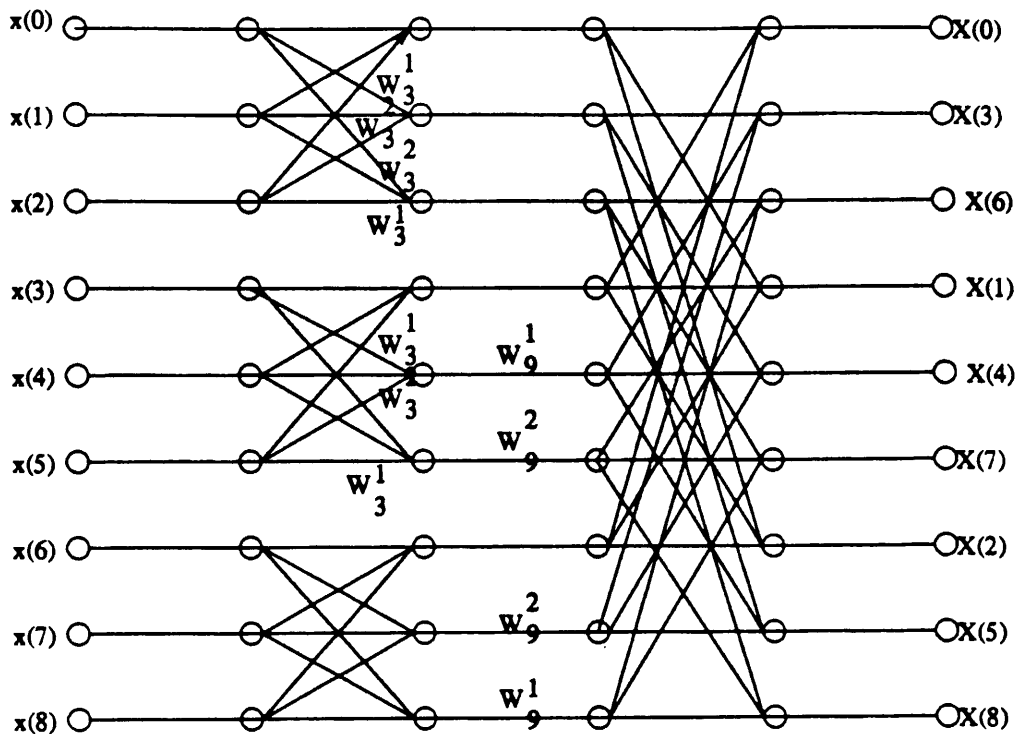

Figure 6.6:

$$x(3l+2) = \sum_{n=0}^2 W_9^{2n} [x(n) + W_3^2 x(n+3) + W_3^1 x(n+6)] W_3^{n1}$$

The number of required complex multiplications is 28. The operations can be performed in-place. see fig 6.7

6.27

(a) Refer to fig 6.8

(b) Refer to fig 6.9

(c) DIF is preferable for computing all points. It is also better when only $X(0), X(1), X(2), X(3)$ are to be calculated. The rule is to compare the number of nontrivial complex multiplies and choose the algorithm with the fewer.

(d) If $M \ll N$ and $L \ll N$, the percentage of savings is

$$\frac{\frac{N}{2} \log_2 N - \frac{ML}{2} \log_2 N}{\frac{N}{2} \log_2 N} \times 100\% = \left(1 - \frac{ML}{N}\right) \times 100\%$$

6.28

(a) Refer to fig 6.10. If data shuffling is not allowed, then $X(0), \dots, X(3)$ should be computed by one DSP. Similarly for $X(4), \dots, X(7)$ and $X(8), \dots, X(11)$ and $X(12), \dots, X(15)$. From the flow diagram the output of every DSP requires all 16 inputs which must therefore be stored in each DSP.

(b) Refer to fig 6.11

(c) The computations necessary for a general FFT are shown in the figure for part (a), $N_g =$

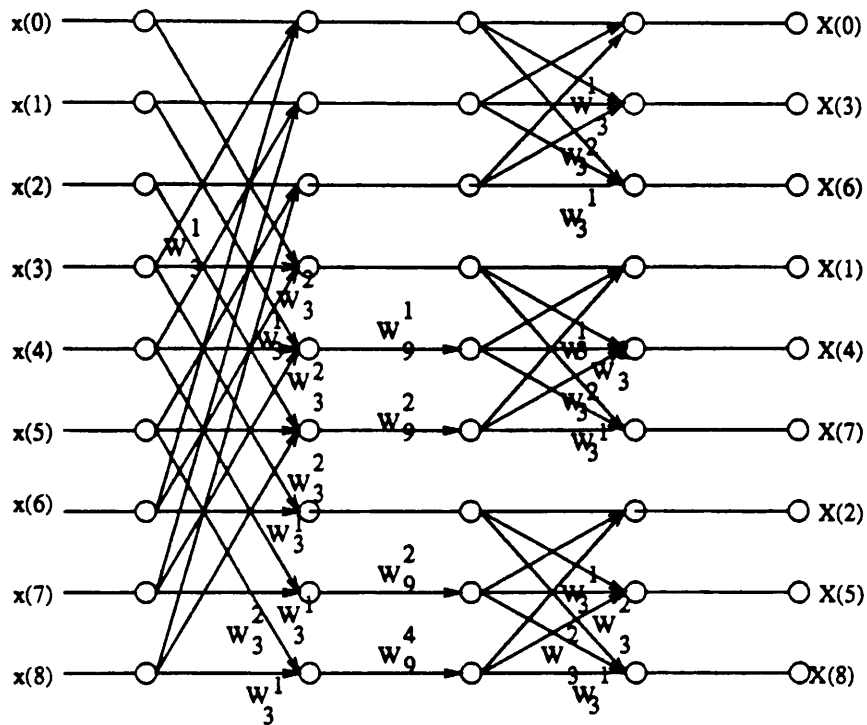

Figure 6.7:

$\frac{N}{2} \log_2 N$. Parallel computation of the DFTs requires

$$\begin{aligned}
 N_p &= \frac{1}{2} \frac{N}{M} \log_2 \frac{N}{M} + \sum_{i=1}^{p-1} \frac{N}{2} \frac{1}{2^i} \\
 &= \frac{N}{2M} \log_2 \frac{N}{M} + N \left(1 - \frac{1}{M}\right)
 \end{aligned}$$

Complex operations, as is seen in the figure for (b). Thus

$$\begin{aligned}
 S &= \frac{N_g}{N_p} \\
 &= \frac{\frac{N}{2} \log_2 N}{\frac{N}{2M} \log_2 \frac{N}{M} + N \left(1 - \frac{1}{M}\right)} \\
 &= \frac{M \log_2 N}{\log_2 N - \log_2 M + 2(M - 1)}
 \end{aligned}$$

6.29

Refer to fig 6.12

$$x(n) = \frac{1}{N} \sum_{k=0}^{N-1} X(k) W_N^{-kn}$$

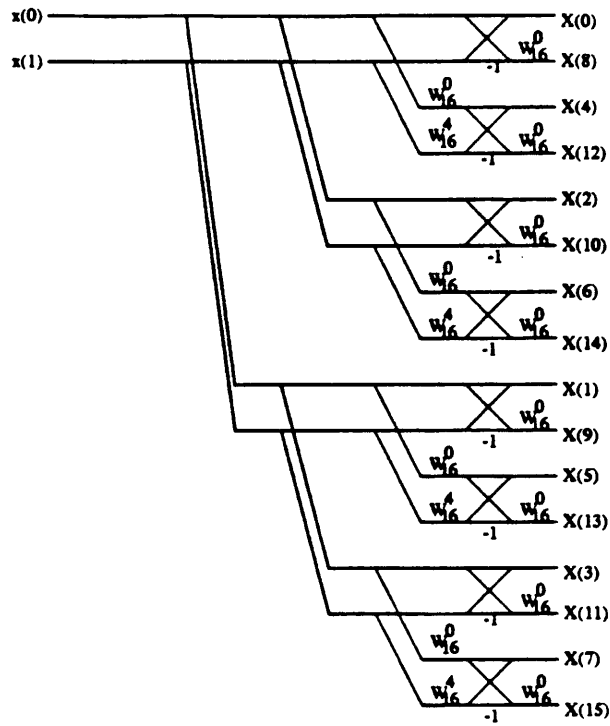

Figure 6.8:

$$\begin{aligned}
 &= \frac{1}{8} \sum_{k \text{ even}} X(k)W_8^{-kn} + \frac{1}{8} \sum_{k \text{ odd}} X(k)W_8^{-kn} \\
 &= \frac{1}{8} \sum_{m=0}^3 X(2m)W_4^{-mn} + \frac{1}{8} \sum_{m=0}^3 X(2m+1)W_4^{-mn}W_8^{-n} \\
 &= \frac{1}{8} \sum_{m=0}^3 [X(2m) + X(2m+1)W_8^{-n}] W_4^{-mn} \\
 x(n) &= \frac{1}{8} \left[\sum_{m=0}^3 X(2m)W_4^{-mn} + W_8^{-n} \sum_{m=0}^3 X(2m+1)W_4^{-mn} \right], \quad 0 \leq n \leq 3 \\
 x(n+4) &= \frac{1}{8} \left[\sum_{m=0}^3 X(2m)W_4^{-mn} - W_8^{-n} \sum_{m=0}^3 X(2m+1)W_4^{-mn} \right], \quad 0 \leq n \leq 3
 \end{aligned}$$

This result can be obtained from the forward DIT FFT algorithm by conjugating each occurrence of $W_N^i \rightarrow W_N^{-i}$ and multiplying each output by $\frac{1}{8}$ (or $\frac{1}{2}$ can be multiplied into the outputs of each stage).

6.30

$$x(n) = \frac{1}{8} \sum_{k=0}^7 X(k)W_8^{-kn}$$

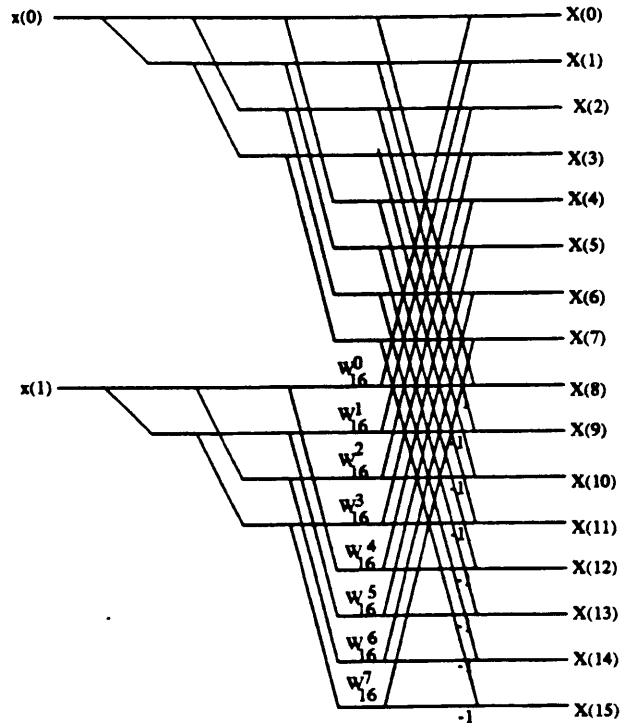

Figure 6.9:

$$\begin{aligned}
 &= \frac{1}{8} \sum_{k=0}^3 X(k)W_8^{-kn} + \frac{1}{8} \sum_{k=4}^7 X(k)W_8^{-kn} \\
 &= \frac{1}{8} \left[\sum_{k=0}^3 X(k)W_8^{-kn} + (-1)^n \sum_{k=0}^3 X(k+4)W_8^{-kn} \right] \\
 x(2l) &= \frac{1}{8} \left[\sum_{k=0}^3 X(k)W_4^{-lk} + \sum_{k=0}^3 X(k+4)W_4^{-lk} \right], \quad l = 0, 1, 2, 3 \\
 x(2l+1) &= \frac{1}{8} \left[\sum_{k=0}^3 X(k)W_4^{-lk}W_8^{-k} - \sum_{k=0}^3 X(k+4)W_4^{-lk}W_8^{-k} \right], \quad l = 0, 1, 2, 3
 \end{aligned}$$

Similar to the DIT case (prob. 6.29) result can be obtained by conjugating each W_N^i and scaling by $\frac{1}{8}$. Refer to fig 6.13

6.31

$$\begin{aligned}
 x(n) &= x^*(N-n) \\
 \text{IDFT}(x^*(n)) &= \frac{1}{N} \sum_{n=0}^{N-1} x^*(n)W_N^{-kn} \\
 &= \frac{1}{N} \sum_{n=0}^{N-1} x(N-n)W_N^{-kn}
 \end{aligned}$$

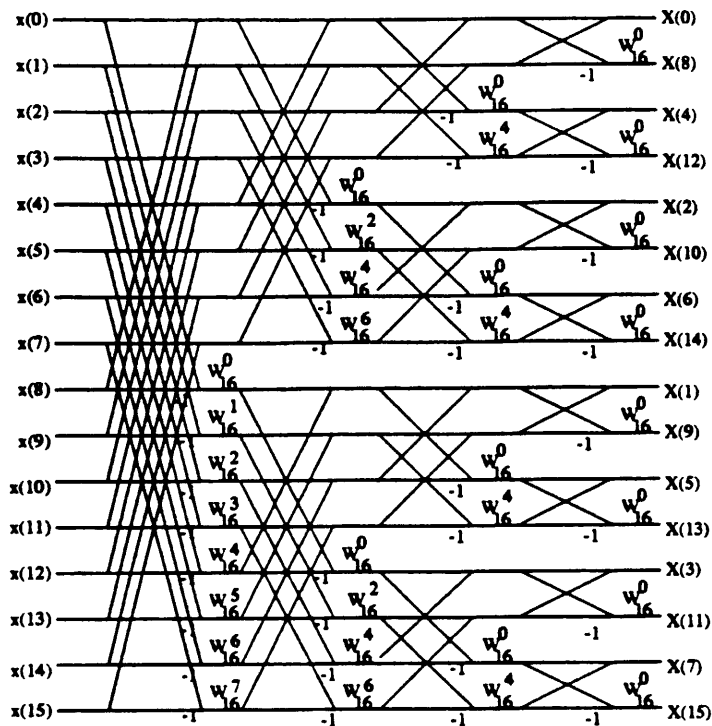

Figure 6.10:

$$\begin{aligned}
 &= \frac{1}{N} \sum_{m=N}^1 x(m) W_N^{-k(N-m)} \\
 &= \frac{1}{N} \sum_{m'=0}^{N-1} x(N-m') W_N^{-km'}
 \end{aligned}$$

Since the IDFT of a Hermitian symmetric sequence is real, we may conjugate all terms in the sum yielding

$$\begin{aligned}
 \text{IDFT}(x^*(n)) &= \frac{1}{N} \sum_{m'=0}^{N-1} x^*(N-m') W_N^{km'} \\
 &= \frac{1}{N} \sum_{n=0}^{N-1} x(n) W_N^{kn} \\
 &= \frac{1}{N} X(k)
 \end{aligned}$$

In general, the IDFT of an N-length sequence can be obtained by reversing the flow of a forward FFT and introducing a scale factor $\frac{1}{N}$. Since the IDFT is apparently capable of producing the (scaled) DFT for a Hermitian symmetric sequence, the reversed flow FFT will produce the desired FFT.

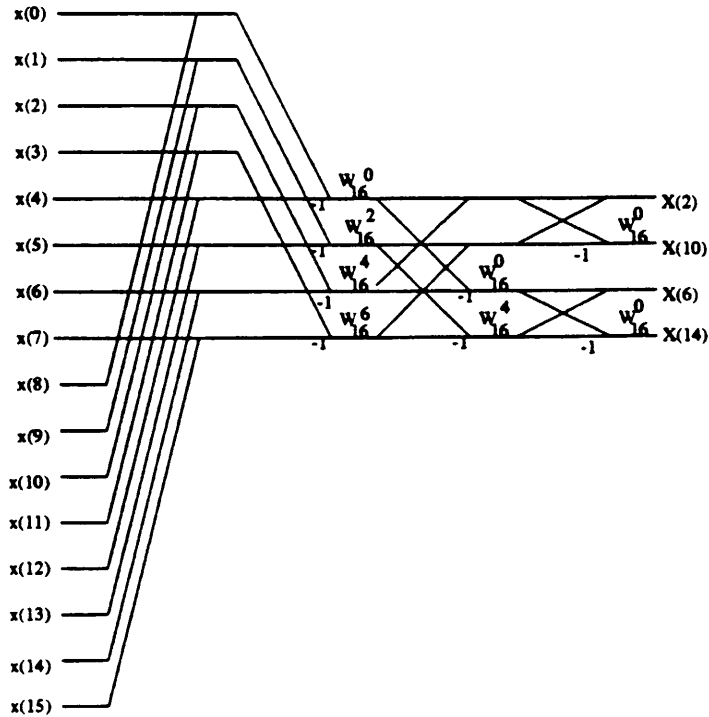

Figure 6.11:

6.32

$$\begin{aligned}
 X(k) &= \sum_{m=0}^{N-1} x(m) W_N^{km} \\
 &= \sum_{m=0}^{N-1} x(m) W_N^{km} W_N^{-kN} \text{ since } W_N^{-kN} = 1 \\
 &= \sum_{m=0}^{N-1} x(m) W_N^{-k(N-m)}
 \end{aligned}$$

This can be viewed as the convolution of the N -length sequence $x(n)$ with the impulse response of a linear filter.

$$\begin{aligned}
 h_k(n) &\triangleq W_N^{kn} u(n), \text{ evaluated at time } N \\
 H_k(z) &= \sum_{n=0}^{\infty} W_N^{kn} z^{-n} \\
 &= \frac{1}{1 - W_N^k z^{-1}} \\
 &= \frac{Y_u(z)}{X(z)} \\
 y_k(n) &= W_N^k y_k(n-1) + x(n), \quad y_k(-1) = 0 \\
 y_k(N) &= X(k)
 \end{aligned}$$

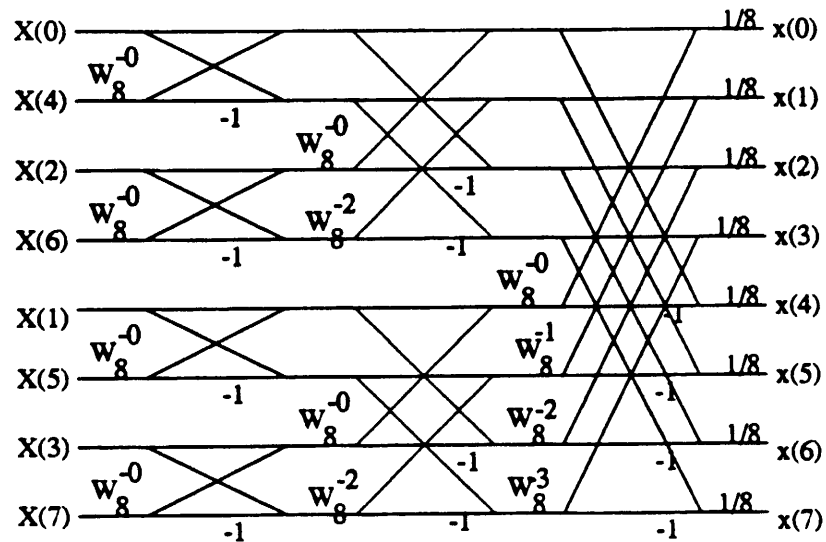

Figure 6.12:

6.33

(a) 11 frequency points must be calculated. Radix-2 FFT requires $\frac{1024}{2} \log_2 1024 \approx 5000$ complex multiplies or 20,000 real multiplies. FFT of radix-4 requires $0.75 \times 5000 = 3,750$ complex multiplies or 15,000 real multiplies. Choose Goertzel.

(b) In this case, direct evaluation requires 10^6 complex multiplies, chirp-z 22×10^3 complex multiplies, and FFT $1000 + \frac{5000}{2} \times 13 = 33 \times 10^3$ complex multiplies. Choose chirp-z.

6.34

In the DIF case, the number of butterflies affecting a given output is $\frac{N}{2}$ in the first stage, $\frac{N}{4}$ in the second, The total number is

$$1 + 2 + \dots + 2^{-1} = 2^{-1} \left(1 - \left(\frac{1}{2}\right)^N\right) = N - 1$$

Every butterfly requires 4 real multiplies, and the error variance is $\frac{\delta^2}{12}$. Under the assumption that the errors are uncorrelated, the variance of the total output quantization error is

$$\sigma_q^2 = 4(N - 1) \frac{\delta^2}{12} = \frac{N\delta^2}{3}$$

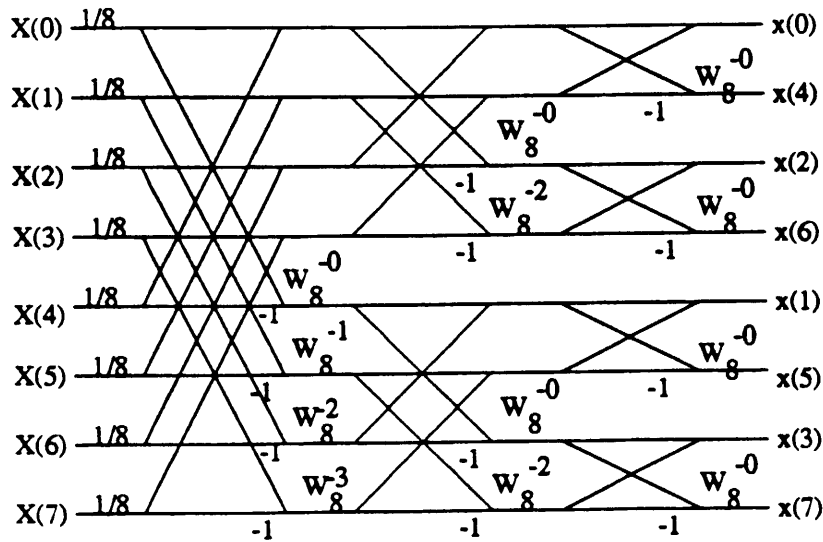

Figure 6.13:

6.35

(a)

$$\begin{aligned}
 \operatorname{Re}[X_{n+1}(k)] &= \frac{1}{2}X_{n+1}(k) + \frac{1}{2}X_{n+1}^*(k) \\
 &= \frac{1}{2}X_n(k) + \frac{1}{2}W_N^m X_n(l) + \frac{1}{2}X_n^*(k) - \frac{1}{2}W_N^{-m} X_n^*(l) \\
 &= \operatorname{Re}[X_n(k)] + \operatorname{Re}[W_N^m X_n(l)]
 \end{aligned}$$

$$\text{since } |X_n(k)| < \frac{1}{2}, \quad |\operatorname{Re}[X_n(k)]| < \frac{1}{2}$$

$$\text{since } |X_l(k)| < \frac{1}{2}, \quad |\operatorname{Re}[W_N^m X_n(l)]| < \frac{1}{2}$$

$$\text{so } |\operatorname{Re}[W_N^m X_n(l)]| < \frac{1}{2}$$

$$\text{Therefore } |\operatorname{Re}[X_{n+1}(k)]| \leq |\operatorname{Re}[X_n(k)]| + |\operatorname{Re}[W_N^m X_n(l)]| < 1$$

The other inequalities are verified similarly. (b)

$$\begin{aligned}
 X_{n+1}(k) &= \operatorname{Re}[X_n(k)] + j\operatorname{Im}[X_n(k)] \\
 &\quad \left[\cos\left(\frac{2\pi}{N}m\right) - j\sin\left(\frac{2\pi}{N}m\right) \right] [\operatorname{Re}[X_n(l)] + j\operatorname{Im}[X_n(l)]] \\
 &= \operatorname{Re}[X_n(k)] + \cos(\cdot)\operatorname{Re}[X_n(l)] + \sin(\cdot)\operatorname{Im}[X_n(l)] \\
 &\quad + j \{ \operatorname{Im}[X_n(k)] + \cos(\cdot)\operatorname{Im}[X_n(l)] + \sin(\cdot)\operatorname{Re}[X_n(l)] \}
 \end{aligned}$$

$$\text{Therefore, } |X_{n+1}(k)| = |X_n(k)| + |X_n(l)| + A$$

$$\text{where } A \triangleq 2\cos(\cdot) \{ \text{Re}[X_n(k)]\text{Re}[X_n(l)] + \text{Im}[X_n(k)]\text{Im}[X_n(l)] \} \\ + 2\sin(\cdot) \{ \text{Re}[X_n(k)]\text{Im}[X_n(l)] - \text{Im}[X_n(k)]\text{Re}[X_n(l)] \}$$

$$\text{also } |X_{n+1}(l)|^2 = |X_n(k)|^2 + |X_n(l)|^2 - A(*)$$

Therefore, if $A \geq 0$,

$$\begin{aligned} \max[|X_{n+1}(k)|, |X_{n+1}(l)|] &= |X_{n+1}(k)| \\ &= \{ |X_n(k)|^2 + |X_n(l)|^2 + A \}^{\frac{1}{2}} \\ &> \max[|X_n(k)|, |X_n(l)|] \end{aligned}$$

By similar means using (*), it can be shown that the same inequality holds if $A < 0$. Also, from the pair of equations for computing the butterfly outputs, we have

$$\begin{aligned} 2X_n(k) &= X_{n+1}(k) + X_{n+1}(l) \\ 2X_n(l) &= W_N^{-m} X_{n+1}(k) - W_N^{-m} X_{n+1}(l) \end{aligned}$$

By a similar method to that employed above, it can be shown that

$$2\max[|X_n(k)|, |X_n(l)|] \geq \max[|X_{n+1}(k)|, |X_{n+1}(l)|]$$

6.36

Refer to fig 6.14.

(d) (1) The frequency interval between successive samples for the plots in parts (a), (b), (c) and

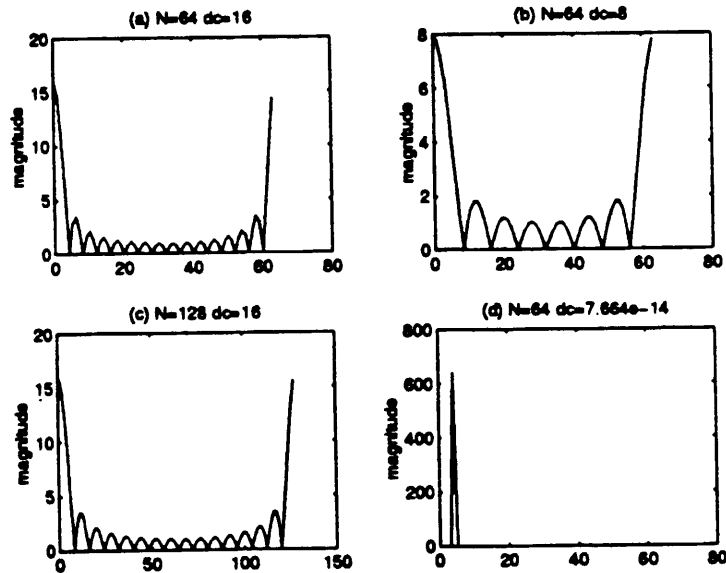

Figure 6.14:

(d) are $\frac{1}{64}$, $\frac{1}{64}$, $\frac{1}{128}$ and $\frac{1}{64}$ respectively.

(2) The dc values computed theoretically and from the plots are given below:

	part a	part b	part c	part d
theoretical	16	8	16	0
practical	16	8	16	$8.203e - 14$

Both theoretical and practical dc values match except in the last case because of the finite word length effects the dc value is not a perfect zero.

- (3) Frequency interval = $\frac{\pi}{N}$.
 (4) Resolution is better with $N = 128$.

6.37

- (a) Refer to fig 6.15.
 (b) Refer to fig 6.15.

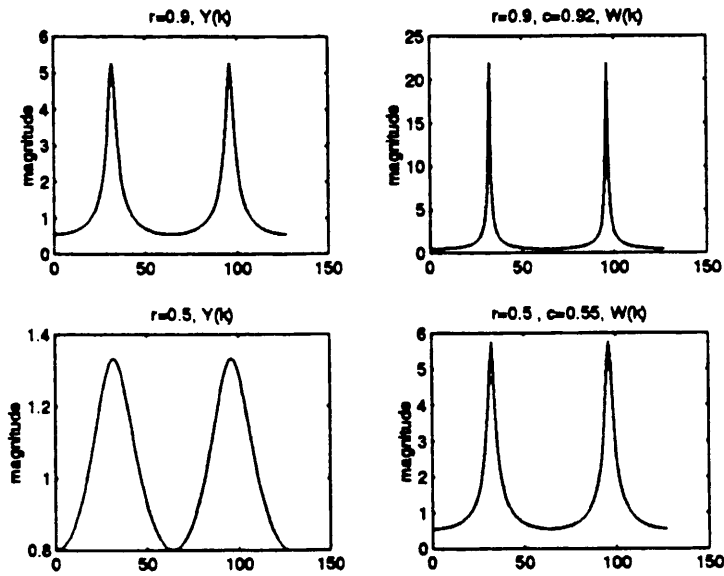

Figure 6.15:

- (c) Refer to fig 6.15.
 (d) Refer to fig 6.15.
 (e) Refer to fig 6.16.

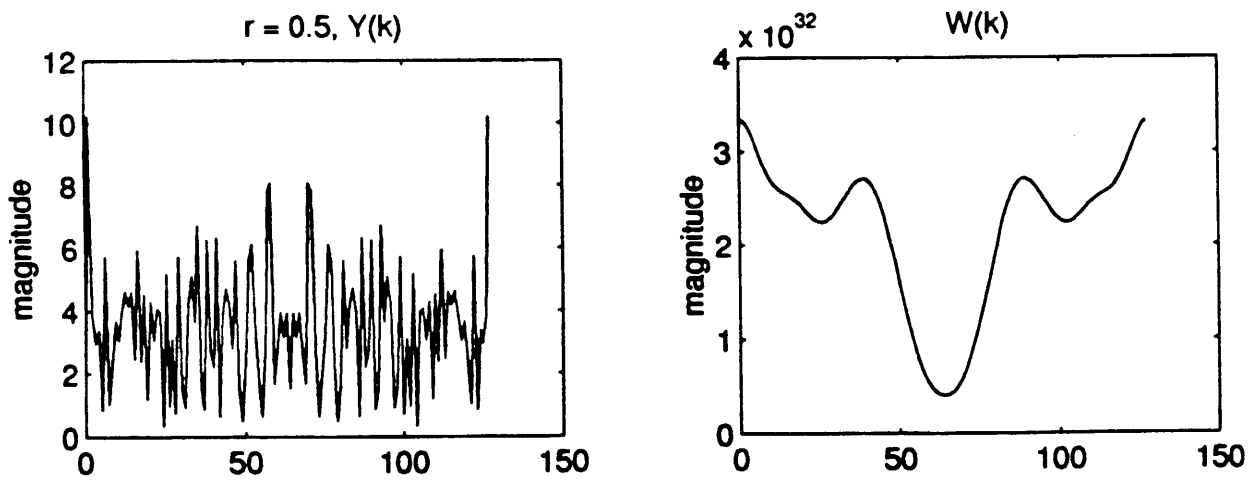

Figure 6.16:

Chapter 7

7.1

- (a) $H(z) = 1 + 2z^{-1} + 3z^{-2} + 4z^{-3} + 3z^{-4} + 2z^{-5} + z^{-6}$. Refer to fig 7.1
 (b) $H(z) = 1 + 2z^{-1} + 3z^{-2} + 3z^{-3} + 2z^{-4} + z^{-5}$. Refer to fig 7.2

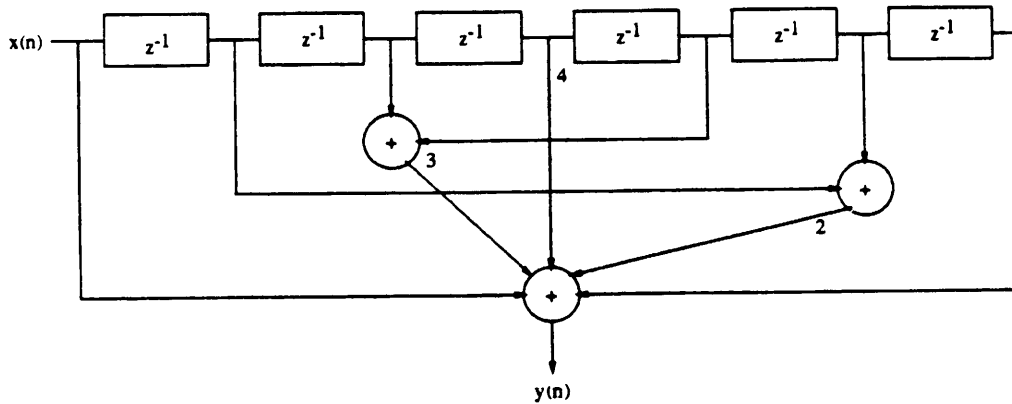

Figure 7.1:

7.2

Refer to fig 7.3

$$\begin{aligned}
 A_4(z) = H(z) &= 1 + 2.88z^{-1} + 3.4048z^{-2} + 1.74z^{-3} + 0.4z^{-4} \\
 B_4(z) &= 0.4 + 1.74z^{-1} + 3.4048z^{-2} + 2.88z^{-3} + z^{-4} \\
 \text{Hence, } K_4 &= 0.4 \\
 A_3(z) &= \frac{A_4(z) - k_4 B_4(z)}{1 - k_4^2} \\
 &= 1 + 2.6z^{-1} + 2.432z^{-2} + 0.7z^{-3}
 \end{aligned}$$

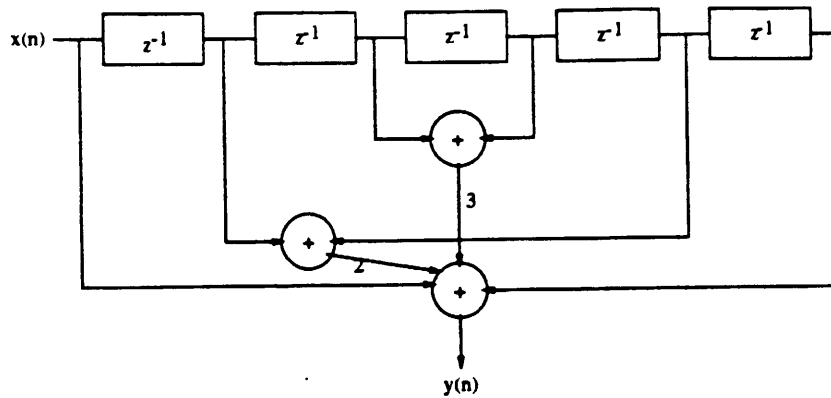

Figure 7.2:

$$\begin{aligned}
 B_3(z) &= 0.7 + 2.432z^{-1} + 2.6z^{-2} + z^{-3} \\
 \text{Hence, } K_3 &= 0.7 \\
 A_2(z) &= \frac{A_3(z) - k_3 B_3(z)}{1 - k_3^2} \\
 &= 1 + 1.76z^{-1} + 1.2z^{-2} \\
 B_2(z) &= 1.2 + 1.76z^{-1} + z^{-2} \\
 \text{Then, } K_2 &= 1.2 \\
 A_1(z) &= \frac{A_2(z) - k_2 B_2(z)}{1 - k_2^2} \\
 &= 1 + 0.8z^{-1} \\
 \text{Therefore, } K_1 &= 0.8
 \end{aligned}$$

Since $K_2 > 1$, the system is not minimum phase.

7.3

$$\begin{aligned}
 V(z) &= X(z) + \frac{1}{2}z^{-1}V(z) \\
 v(n) &= x(n) + \frac{1}{2}v(n-1) \\
 Y(z) &= 2[3X(z) + V(z)] + 2z^{-1}V(z) \\
 H(z) &= \frac{Y(z)}{X(z)} \\
 &= \frac{8 - z^{-1}}{1 - 0.5z^{-1}} \\
 h(n) &= 8(0.5)^n u(n) - (0.5)^{n-1} u(n-1)
 \end{aligned}$$

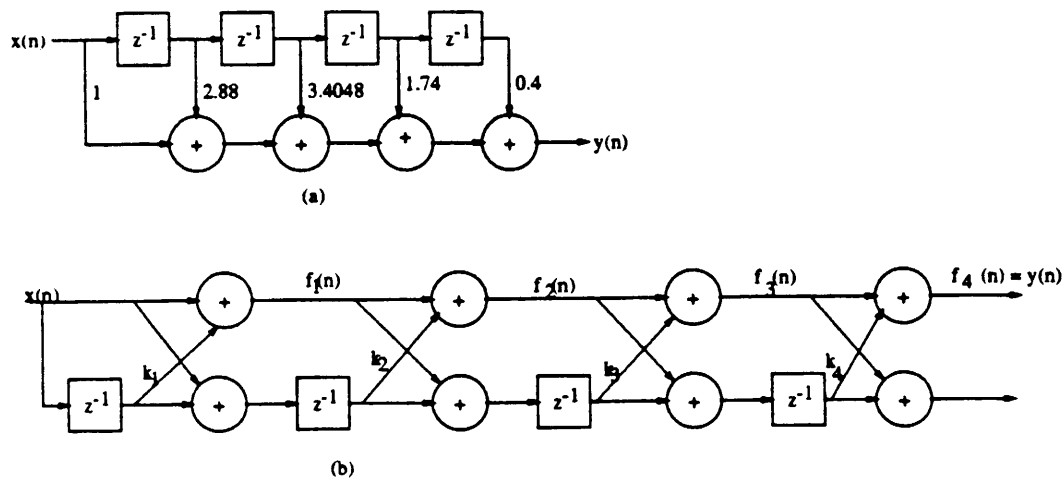

Figure 7.3: (a) Direct form. (b) Lattice form

7.4

$$H(z) = 5 + \frac{3z^1}{1 + \frac{1}{3}z^{-1}} + \frac{1 + 2z^1}{1 - \frac{1}{2}z^{-1}}$$

$$h(n) = 5\delta(n) + 3\left(-\frac{1}{3}\right)^{n-1}u(n-1) + \left(\frac{1}{2}\right)^n u(n) + 2\left(\frac{1}{2}\right)^{n-1}u(n-1)$$

7.5

$$\begin{aligned} H(z) &= \frac{6 + \frac{9}{2}z^1 - \frac{5}{3}z^{-2}}{\left(1 + \frac{1}{3}z^{-1}\right)\left(1 - \frac{1}{2}z^{-1}\right)} \\ &= \frac{6 + \frac{9}{2}z^1 - \frac{5}{3}z^{-2}}{1 - \frac{1}{6}z^1 - \frac{1}{6}z^{-2}} \end{aligned}$$

Refer to fig 7.4

7.6

$$\text{For the first system, } H(z) = \frac{1}{1 - b_1 z^{-1}} + \frac{1}{1 - b_2 z^{-1}}$$

$$H(z) = \frac{1 - (b_1 + b_2)z^{-1}}{(1 - b_1 z^{-1})(1 - b_2 z^{-1})}$$

$$\text{For the second system, } H(z) = \frac{c_0 + c_1 z^{-1}}{(1 - d_1 z^{-1})(1 - a_2 z^{-1})}$$

$$\text{clearly, } c_0 = 1$$

$$c_1 = -(b_1 + b_2)$$

$$d_1 = b_1$$

$$a_2 = b_2$$

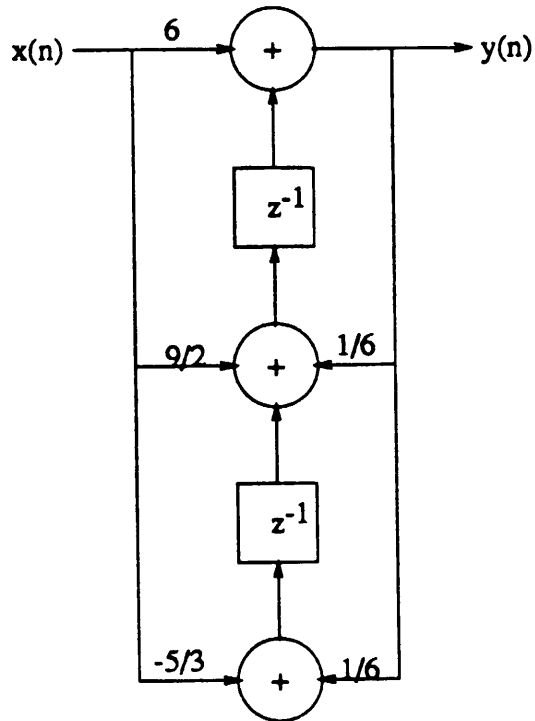

Figure 7.4:

7.7

(a)

$$y(n) = a_1 y(n-1) + a_2 y(n-2) + b_0 x(n) + b_1 x(n-1) + b_2 x(n-2)$$

$$H(z) = \frac{b_0 + b_1 z^{-1} + b_2 z^{-2}}{1 + a_1 z^{-1} + a_2 z^{-2}}$$

(b)

$$H(z) = \frac{1 + 2z^{-1} + z^{-2}}{1 + 1.5z^{-1} + 0.9z^{-2}}$$

$$\text{Zeros at } z = -1, -1$$

$$\text{Poles at } z = -0.75 \pm j0.58$$

Since the poles are inside the unit circle, the system is stable.

$$H(z) = \frac{1 + 2z^{-1} + z^{-2}}{1 + z^{-1} - 2z^{-2}}$$

$$\text{Zeros at } z = -1, -1$$

$$\text{Poles at } z = 2, -1$$

The system is unstable.

(c)

$$x(n) = \cos\left(\frac{\pi}{3}n\right)$$

$$\begin{aligned}
 H(z) &= \frac{1}{1 + z^{-1} - 0.99z^{-2}} \\
 H(w) &= \frac{1}{1 + e^{-jw} - 0.99e^{-j2w}} \\
 H\left(\frac{\pi}{3}\right) &= 100e^{-j\frac{\pi}{3}} \\
 \text{Hence, } y(n) &= 100\cos\left(\frac{\pi}{3}n - \frac{\pi}{3}\right)
 \end{aligned}$$

7.8

$$\begin{aligned}
 y(n) &= \frac{1}{4}y(n-2) + x(n) \\
 H(z) &= \frac{1}{1 - \frac{1}{4}z^{-2}}
 \end{aligned}$$

(a)

$$\begin{aligned}
 h(n) &= \frac{1}{2} \left[\left(\frac{1}{2}\right)^n + \left(-\frac{1}{2}\right)^n \right] u(n) \\
 H(z) &= \frac{\frac{1}{2}}{1 - \frac{1}{2}z^{-1}} + \frac{\frac{1}{2}}{1 + \frac{1}{2}z^{-1}}
 \end{aligned}$$

(b)

$$\begin{aligned}
 x(n) &= \left[\left(\frac{1}{2}\right)^n + \left(-\frac{1}{2}\right)^n \right] u(n) \\
 X(z) &= \frac{1}{1 - \frac{1}{2}z^{-1}} + \frac{1}{1 + \frac{1}{2}z^{-1}} \\
 X(z) &= \frac{2}{1 - \frac{1}{4}z^{-2}} \\
 Y(z) &= X(z)H(z) \\
 &= \frac{1}{1 + \frac{1}{2}z^{-1}} + \frac{1}{1 - \frac{1}{2}z^{-1}} + \frac{-\frac{1}{2}z^{-1}}{(1 - \frac{1}{2}z^{-1})^2} + \frac{\frac{1}{2}z^{-1}}{(1 + \frac{1}{2}z^{-1})^2} \\
 y(n) &= \left[\left(\frac{1}{2}\right)^n + \left(-\frac{1}{2}\right)^n - n\left(\frac{1}{2}\right)^n + n\left(-\frac{1}{2}\right)^n \right] u(n)
 \end{aligned}$$

(c) Refer to fig 7.5

(d)

$$\begin{aligned}
 H(w) &= \frac{1}{1 - \frac{1}{4}e^{-j2w}} \\
 &= \frac{4}{\sqrt{17 - 8\cos 2w}} \angle -\tan^{-1} \frac{\sin 2w}{4 - \cos 2w}
 \end{aligned}$$

Refer to fig 7.6.

7.9

(a)

$$H(z) = \frac{1 + \frac{1}{3}z^{-1}}{1 - \frac{3}{4}z^{-1} + \frac{1}{8}z^{-2}}$$

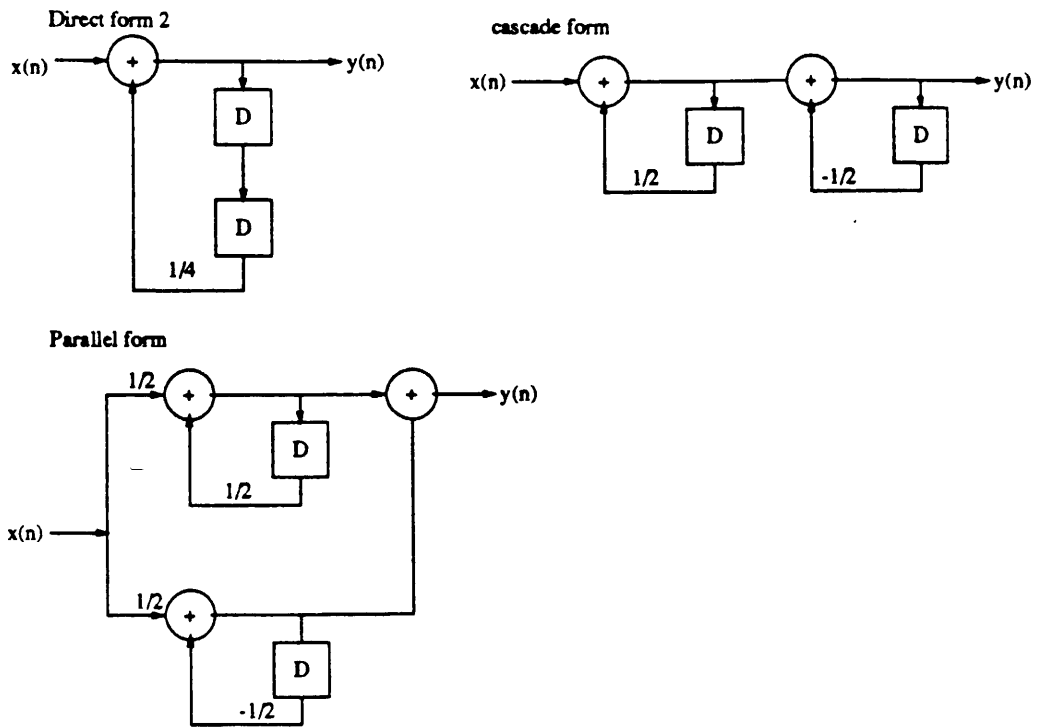

Figure 7.5:

$$\begin{aligned}
 &= \frac{1 + \frac{1}{3}z^{-1}}{(1 - \frac{1}{2}z^{-1})(1 - \frac{1}{4}z^{-1})} \\
 &= \frac{\frac{10}{3}}{1 - \frac{1}{2}z^{-1}} + \frac{-\frac{7}{3}}{1 - \frac{1}{4}z^{-1}}
 \end{aligned}$$

Refer to fig 7.7

(b)

$$\begin{aligned}
 H(z) &= \frac{0.7(1 - 0.36z^{-2})}{1 + 0.1z^{-1} - 0.72z^{-2}} \\
 &= \frac{0.7(1 - 0.6z^{-1})(1 + 0.6z^{-1})}{(1 + 0.9z^{-1})(1 - 0.8z^{-1})} \\
 &= 0.35 - \frac{0.1647}{1 + 0.9z^{-1}} - \frac{0.1853}{1 - 0.8z^{-1}}
 \end{aligned}$$

Refer to fig 7.8

(c)

$$\begin{aligned}
 H(z) &= \frac{3(1 + 1.2z^{-1} + 0.2z^{-2})}{1 + 0.1z^{-1} - 0.2z^{-2}} \\
 &= \frac{3(1 + 0.2z^{-1})(1 + z^{-1})}{(1 + 0.5z^{-1})(1 - 0.4z^{-1})} \\
 &= -3 + \frac{7}{1 - 0.4z^{-1}} - \frac{1}{1 + 0.5z^{-1}}
 \end{aligned}$$

Refer to fig 7.9

(d)

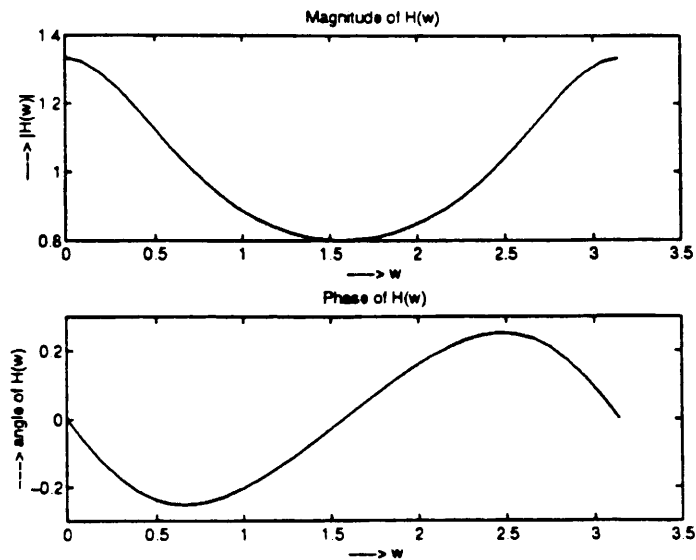

Figure 7.6:

$$\begin{aligned}
 H(z) &= \frac{2(1-z^{-1})(1+\sqrt{2}z^{-1}+z^{-2})}{(1+0.5z^{-1})(1-0.9z^{-1}+0.8z^{-2})} \\
 &= \frac{2+(2\sqrt{2}-2)z^{-1}+(2-2\sqrt{2})z^{-2}-2z^{-3}}{1-0.4z^{-1}+0.36z^{-2}+0.405z^{-3}} \\
 &= \frac{A}{1+0.5z^{-1}} + \frac{B+Cz^{-1}}{1-0.9z^{-1}+0.8z^{-2}}
 \end{aligned}$$

Refer to fig 7.10

(e)

$$\begin{aligned}
 H(z) &= \frac{1+z^{-1}}{1-\frac{1}{2}z^{-1}-\frac{1}{4}z^{-2}} \\
 &= \frac{1+z^{-1}}{(1-0.81z^{-1})(1+0.31z^{-1})} \\
 &= \frac{1.62}{1-0.81z^{-1}} + \frac{-0.62}{1+0.31z^{-1}}
 \end{aligned}$$

Refer to fig 7.11

(f) $H(z) = \frac{1-z^{-1}+z^{-2}}{1-z^{-1}+0.5z^{-2}} \Rightarrow$ Complex valued poles and zeros. Refer to fig 7.12 All the above systems are stable.

7.10

Refer to fig 7.13

$$\begin{aligned}
 H(z) &= \frac{1}{1-2r\cos\omega_0 z^{-1}+r^2 z^{-2}} \\
 (1) \quad V(z) &= X(z) - r\sin\omega_0 z^{-1}Y(z) \\
 (2) \quad W(z) &= V(z) - r\cos\omega_0 z^{-1}W(z) \\
 (3) \quad Y(z) &= r\cos\omega_0 z^{-1}Y(z) - r\sin\omega_0 z^{-1}W(z)
 \end{aligned}$$

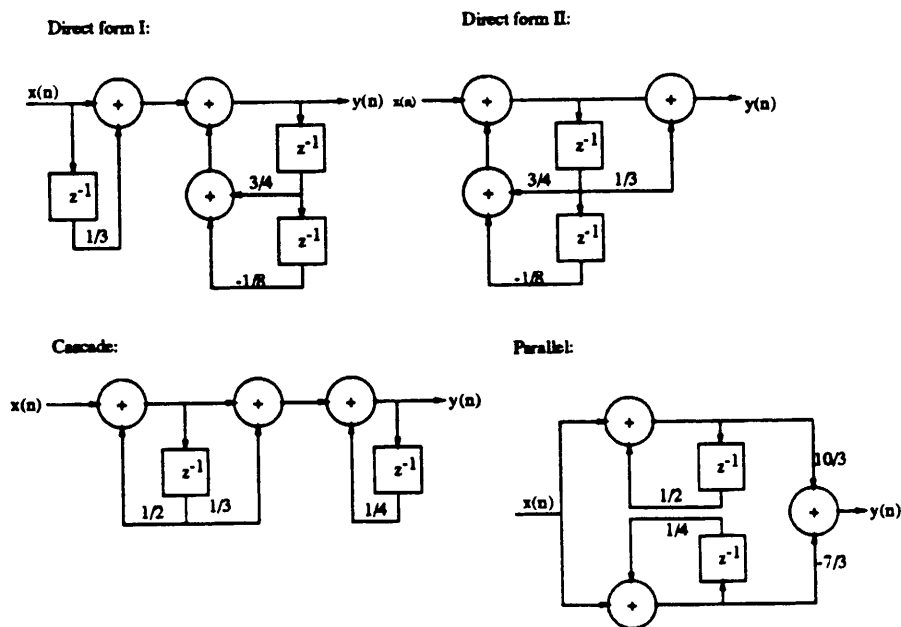

Figure 7.7:

By combining (1) and (2) we obtain

$$(4) \quad W(z) = \frac{1}{1 - r \cos \omega_0 z^{-1}} X(z) - \frac{r \sin \omega_0 z^{-1}}{1 - r \cos \omega_0 z^{-1}} Y(z)$$

Use (4) to eliminate $W(z)$ in (3). Thus,

$$\begin{aligned} Y(z)[(1 - r \cos \omega_0 z^{-1})^2 + r^2 \sin^2 \omega_0 z^{-2}] &= X(z) \\ Y(z)[1 - 2r \cos \omega_0 z^{-1} + (r^2 \cos^2 \omega_0 + r^2 \sin^2 \omega_0)z^{-2}] &= X(z) \\ \frac{Y(z)}{X(z)} &= \frac{1}{1 - 2r \cos \omega_0 z^{-1} + r^2 z^{-2}} \end{aligned}$$

7.11

$$\begin{aligned} A_0(z) &= B_0(z) = 1 \\ A_1(z) &= A_0(z) + k_1 B_0(z)z^{-1} \\ &= 1 + \frac{1}{2}z^{-1} \\ B_1(z) &= \frac{1}{2} + z^{-1} \\ A_2(z) &= A_1(z) + k_2 B_1(z) \\ &= 1 + 0.3z^{-1} + 0.6z^{-2} \\ B_2(z) &= 0.6 + 0.3z^{-1} + z^{-2} \\ A_3(z) &= A_2(z) + k_3 B_2(z) \end{aligned}$$

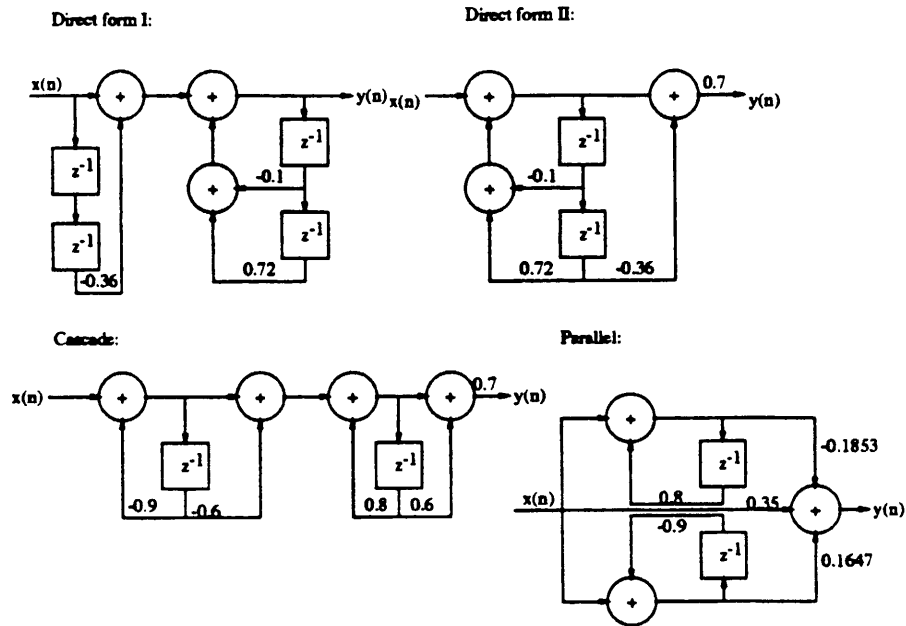

Figure 7.8:

$$= 1 - 0.12z^{-1} + 0.39z^{-2} - 0.7z^{-3}$$

$$B_3(z) = -0.7 + 0.39z^{-1} - 0.12z^{-2} + z^{-3}$$

$$A_4(z) = A_3(z) + k_4 B_3(z)$$

$$= 1 - \frac{53}{150}z^{-1} + 0.52z^{-2} - 0.74z^{-3} + \frac{1}{3}z^{-4}$$

$$\text{Therefore, } H(z) = C \left(1 - \frac{53}{150}z^{-1} + 0.52z^{-2} - 0.74z^{-3} + \frac{1}{3}z^{-4} \right)$$

where C is a constant

7.12

Refer to fig 7.14

$$H_k(z) = \frac{b_{0k} + b_{1k}z^{-1} + b_{2k}z^{-2}}{1 + a_{1k}z^{-1} + a_{2k}z^{-2}}$$

$$y_k(n) = b_{0k}x_k(n) + w_{1k}(n-1)$$

$$w_{1k}(n) = b_{1k}x(n) - a_{1k}y_k(n) + w_{2k}(n-1)$$

$$w_{2k}(n) = b_{2k}x(n) - a_{2k}y_k(n)$$

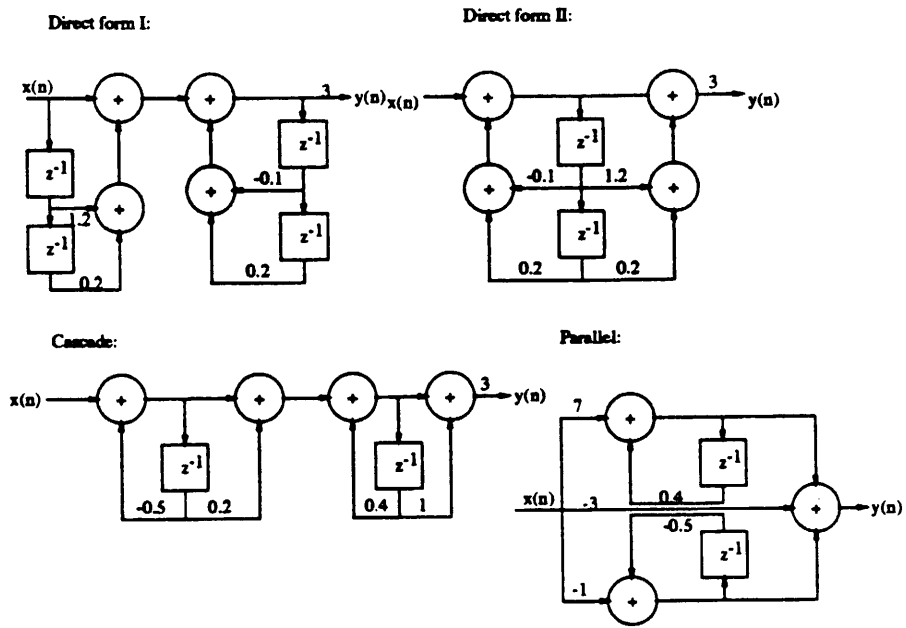

Figure 7.9:

7.13

```

YJM1 = G * XIN
DO 20 J=1,K
  YJ=B(J,0) * XIN + W1(J)
  W1(J) = B(J,1)*XIN - A(J,1)*YJ + W2(J)
  W2(J) = B(J,2)*XIN - A(J,2)*YJ
  YJM1 = YJM1 + YJ
20 CONTINUE  YOUT = YJM1  RETURN

```

7.14

```

YJM1 = XIN
DO 20 J=1,K
  W = -A(J,1) * WOLD1 - A(J,2) * WOLD2 + YMJ1
  YJ = W + B(J,1)*WOLD1 + B(J,2)*WOLD2
  WOLD2 = WOLD1
  WOLD1 = W
  YJM1 = YJ
20 CONTINUE
YOUT = YJ
RETURN

```

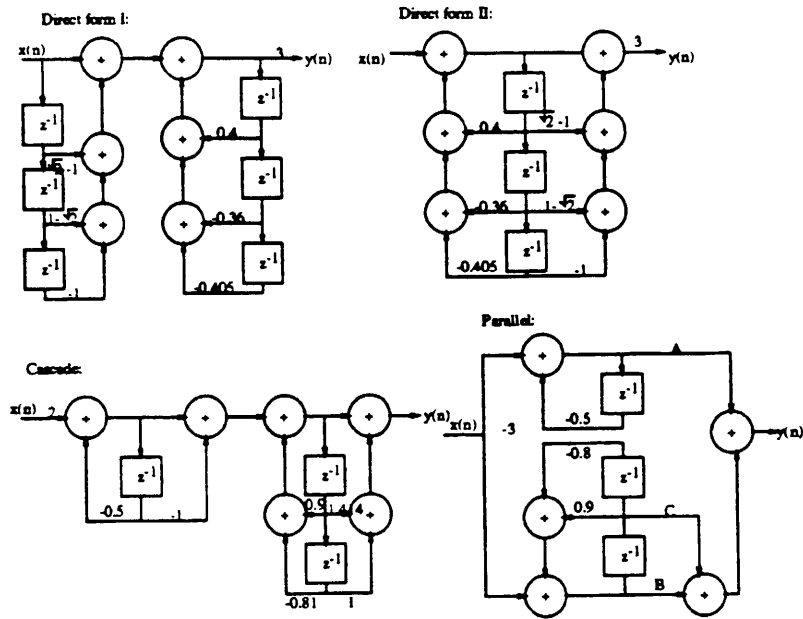

Figure 7.10:

7.15

$$\begin{aligned}
 H(z) = A_2(z) &= 1 + 2z^{-1} + \frac{1}{3}z^{-2} \\
 B_2(z) &= \frac{1}{3} + 2z^{-1} + z^{-2} \\
 k_2 &= \frac{1}{3} \\
 A_1(z) &= \frac{A_2(z) - k_2 B_2(z)}{1 - k_2^2} \\
 &= 1 + \frac{3}{2}z^{-1} \\
 k_1 &= \frac{3}{2}
 \end{aligned}$$

7.16

(a)

$$\begin{aligned}
 \begin{bmatrix} A_1(z) \\ B_1(z) \end{bmatrix} &= \begin{bmatrix} 1 & k_1 \\ k_1 & 1 \end{bmatrix} \begin{bmatrix} 1 \\ z^{-1} \end{bmatrix} = \begin{bmatrix} 1 + \frac{1}{2}z^{-1} \\ \frac{1}{2} + z^{-1} \end{bmatrix} \\
 \begin{bmatrix} A_2(z) \\ B_2(z) \end{bmatrix} &= \begin{bmatrix} 1 & -\frac{1}{3} \\ -\frac{1}{3} & 1 \end{bmatrix} \begin{bmatrix} A_1(z) \\ z^{-1} B_1(z) \end{bmatrix} = \begin{bmatrix} 1 + \frac{1}{3}z^{-1} - \frac{1}{3}z^{-2} \\ -\frac{1}{3} + \frac{1}{3}z^{-1} + z^{-2} \end{bmatrix}
 \end{aligned}$$

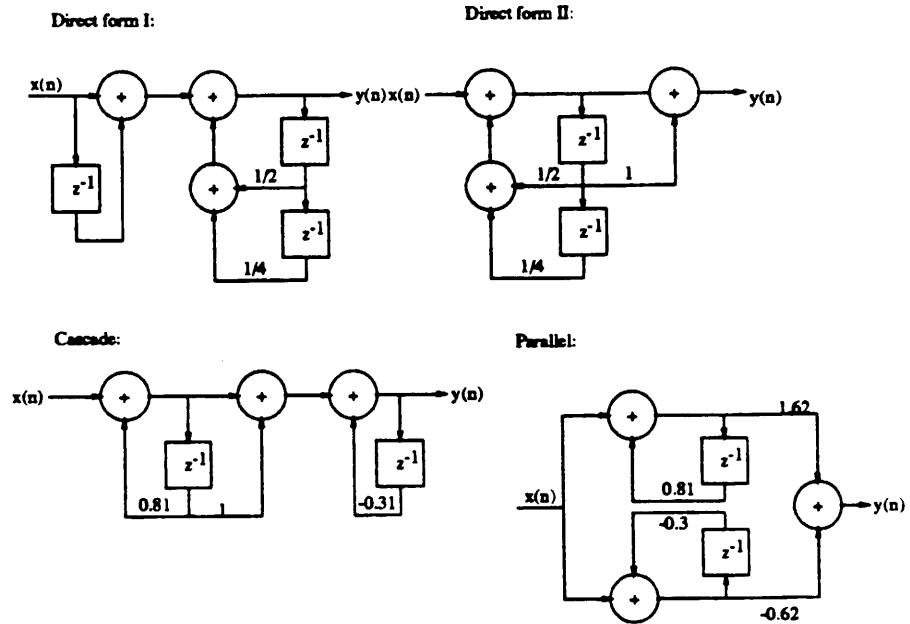

Figure 7.11:

$$\begin{bmatrix} A_3(z) \\ B_3(z) \end{bmatrix} = \begin{bmatrix} 1 & 1 \\ 1 & 1 \end{bmatrix} \begin{bmatrix} A_2(z) \\ z^{-1}B_2(z) \end{bmatrix}$$

$$H_1(z) = A_3(z) = 1 + z^{-3} \Rightarrow$$

zeros at $z = -1, e^{\pm j\frac{2\pi}{3}}$
(b)

$$\begin{aligned} H_2(z) &= A_2(z) - z^{-1}B_2(z) \\ &= 1 + \frac{2}{3}z^{-1} - \frac{2}{3}z^{-2} - z^{-3} \end{aligned}$$

$$\text{The zeros are } z = 1, \frac{-5 \pm j\sqrt{11}}{6}$$

(c) If the magnitude of the last coefficient $|k_N| = 1$, i.e., $k_N = \pm 1$, all the zeros lie on the unit circle.

(d) Refer to fig 7.15. We observe that the filters are linear phase filters with phase jumps at the zeros of $H(z)$.

7.17

(a) Refer to fig 7.16

Direct form I:

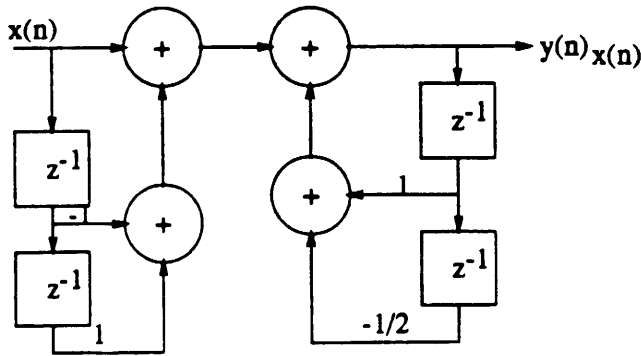

Direct form II, cascade, parallel:

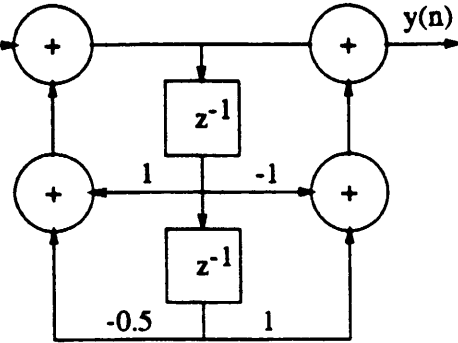

Figure 7.12:

$$\begin{aligned}
 x(n) &= \delta(n) \\
 f_1(n) &= \delta(n) + 0.65\delta(n-1) \\
 g_1(n) &= 0.65\delta(n) + \delta(n-1) \\
 f_2(n) &= f_1(n) - 0.34g_1(n-1) \\
 &= \delta(n) + 0.429\delta(n-1) - 0.34\delta(n-2) \\
 g_2(n) &= -0.34f_1(n) + g_1(n-1) \\
 &= -0.34\delta(n) + 0.429\delta(n-1) + \delta(n-2) \\
 h(n) = f_3(n) &= f_2(n) + 0.8g_2(n-1) \\
 &= \delta(n) + 0.157\delta(n-1) + 0.0032\delta(n-2) + 0.8\delta(n-3)
 \end{aligned}$$

(b) $H(z) = 1 + 0.157z^{-1} + 0.0032z^{-2} + 0.8z^{-3}$. Refer to fig 7.17

7.18

(a)

$$\begin{aligned}
 H(z) &= \frac{C_3(z)}{A_3(z)} \\
 A_3(z) &= 1 + 0.9z^{-1} - 0.8z^{-2} + 0.5z^{-3} \\
 B_3(z) &= 0.5 - 0.8z^{-1} + 0.9z^{-2} + z^{-3} \\
 k_3 &= 0.5
 \end{aligned}$$

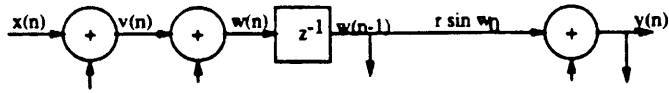

Figure 7.13:

$$\begin{aligned}
 A_2(z) &= \frac{A_3(z) - k_3 B_3(z)}{1 - k_3^2} \\
 &= 1 + 1.73z^{-1} - 1.67z^{-2} \\
 B_2(z) &= -1.67 + 1.73z^{-1} + z^{-2} \\
 k_2 &= -1.67 \\
 A_1(z) &= \frac{A_2(z) - k_2 B_2(z)}{1 - k_2^2} \\
 &= 1 + 1.62z^{-1} \\
 B_1(z) &= 1.62 + z^{-1} \\
 k_1 &= 1.62 \\
 C_3(z) &= 1 + 2z^{-1} + 3z^{-2} + 2z^{-3} \\
 D_3(z) &= 2 + 3z^{-1} + 2z^{-2} + z^{-3} \\
 k_3 &= 2 \\
 C_2(z) &= \frac{C_3(z) - k_3 D_3(z)}{1 - k_3^2} \\
 &= 1 + \frac{4}{3}z^{-1} + \frac{1}{3}z^{-2} \\
 D_2(z) &= \frac{1}{3} + \frac{4}{3}z^{-1} + z^{-2} \\
 k_2 &= \frac{1}{3} \\
 C_1(z) &= \frac{C_2(z) - k_2 D_2(z)}{1 - k_2^2} \\
 &= 1 + \frac{3}{4}z^{-1} \\
 D_1(z) &= \frac{3}{4} + z^{-1}
 \end{aligned}$$

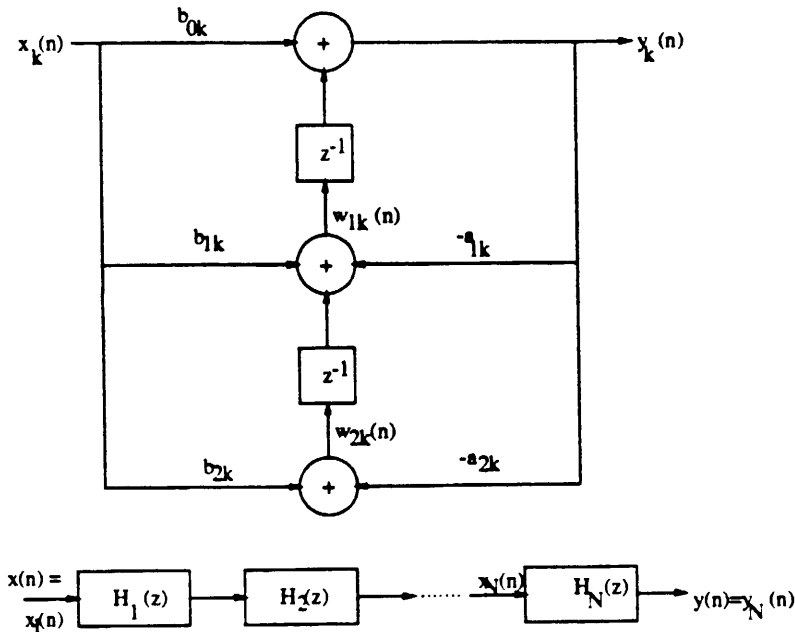

Figure 7.14:

$$k_1 = \frac{3}{4}$$

$$C_3(z) = v_0 + v_1 D_1(z) + v_2 D_2(z) + v_3 D_3(z)$$

$$= 1 + 2z^{-1} + 3z^{-2} + 2z^{-3}$$

From the equations, we obtain

$$v_0 = -\frac{107}{48}$$

$$v_1 = -\frac{13}{4}$$

$$v_2 = -1$$

$$v_3 = 2$$

The equivalent lattice-ladder structure is: Refer to fig 7.18

(b) $A_3(z) = 1 + 0.9z^{-1} - 0.8z^{-2} + 0.5z^{-3}$, $|k_1| > 1$ and $|k_2| > 1 \Rightarrow$ the system is unstable.

7.19

Refer to fig 7.19

$$Y(z) = [r \sin \theta X(z) + r \cos \theta Y(z) - r \sin \theta C(z)] z^{-1}$$

$$C(z) = [-r \cos \theta X(z) + r \sin \theta Y(z) + r \cos \theta C(z)] z^{-1}$$

$$H(z) = \frac{Y(z)}{X(z)}$$

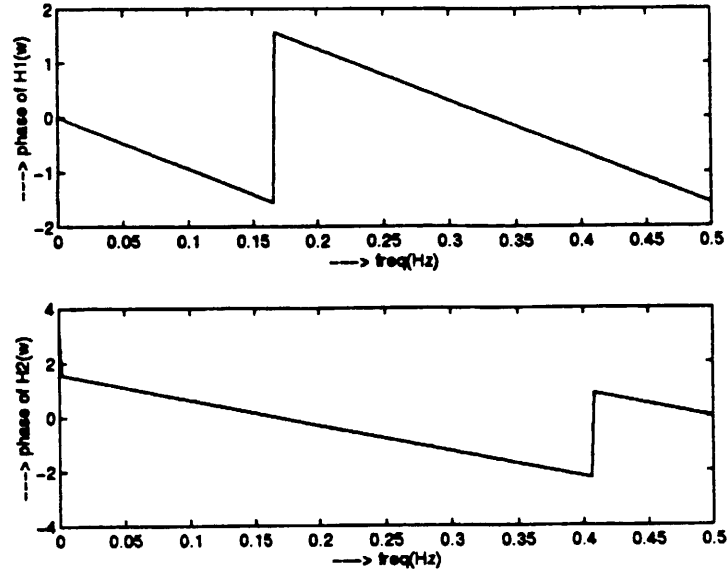

Figure 7.15:

$$= \frac{r \sin \Theta z^{-1}}{1 - 2r \cos \Theta z^{-1} + r^2 z^{-2}}$$

Hence, $h(n) = r^n \sin(\Theta n) u(n)$

and $y(n) = r \sin \Theta x(n-1) + 2r \cos \Theta y(n-1) - r^2 y(n-2)$

The system has a zero at $z = 0$ and poles at $z = re^{\pm j\Theta}$.

7.20

$$H(z) = \frac{1}{1 - 2r \cos \omega_0 z^{-1} + r^2 z^{-2}}$$

$$= 1 + \frac{r \cos \omega_0 - j \frac{r \cos 2\omega_0}{2 \sin \omega_0}}{z - (r \cos \omega_0 + j r \sin \omega_0)} + \frac{r \cos \omega_0 + j \frac{r \cos 2\omega_0}{2 \sin \omega_0}}{z - (r \cos \omega_0 - j r \sin \omega_0)}$$

$$S(z) = \frac{r \cos \omega_0 - j \frac{r \cos 2\omega_0}{2 \sin \omega_0}}{z - (r \cos \omega_0 + j r \sin \omega_0)} X(z)$$

$$s(n) = v_1(n) + j v_2(n)$$

$$p = \alpha_1 + j \alpha_2$$

$$\Rightarrow \alpha_1 = r \cos \omega_0$$

$$\alpha_2 = r \sin \omega_0$$

$$A = q_1 + j q_2$$

$$\Rightarrow q_1 = r \cos \omega_0$$

$$q_2 = \frac{-r \cos \omega_0}{2 \sin \omega_0}$$

$$v_1(n+1) = \alpha_1 v_1(n) - \alpha_2 v_2(n) + q_1 x(n)$$

$$= r \cos \omega_0 v_1(n) - r \sin \omega_0 v_2(n) + r \cos \omega_0 x(n)$$

$$v_2(n) = \alpha_2 v_1(n) + \alpha_1 v_2(n) + q_2 x(n)$$

$$= r \sin \omega_0 v_1(n) + r \cos \omega_0 v_2(n) + \frac{-r \cos \omega_0}{2 \sin \omega_0} x(n)$$

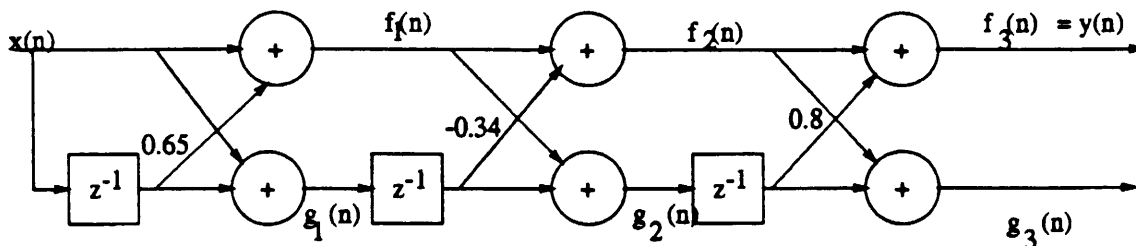

Figure 7.16:

or, equivalently,

$$\underline{v}(n+1) = \begin{bmatrix} r\cos\omega_0 & -r\sin\omega_0 \\ r\sin\omega_0 & r\cos\omega_0 \end{bmatrix} \underline{v}(n) + \begin{bmatrix} r\cos\omega_0 \\ \frac{r\cos\omega_0}{2\sin\omega_0} \end{bmatrix} x(n)$$

$$\begin{aligned} y(n) &= s(n) + s^*(n) + x(n) \\ &= 2v_1(n) + x(n) \end{aligned}$$

or, equivalently,

$$y(n) = [2 \ 0] \underline{v}(n) + x(n)$$

where

$$\underline{v}(n) = \begin{bmatrix} v_1(n) \\ v_2(n) \end{bmatrix}$$

7.21

(a)

$$\begin{aligned} k_1 &= 0.6 \\ A_1(z) &= 1 + 0.6z^{-1} \\ B_1(z) &= 0.6 + z^{-1} \\ A_2(z) &= A_1(z) + k_2 B_1(z)z^{-1} \\ &= 1 + 0.78z^{-1} + 0.3z^{-2} \\ B_2(z) &= 0.3 + 0.78z^{-1} + z^{-2} \\ A_3(z) &= A_2(z) + k_3 B_2(z)z^{-1} \\ &= 1 + 0.93z^{-1} + 0.69z^{-2} + 0.5z^{-3} \\ B_3(z) &= 0.5 + 0.69z^{-1} + 0.93z^{-2} + z^{-3} \\ H(z) = A_4(z) &= A_3(z) + k_4 B_3(z)z^{-1} \\ &= 1 + 1.38z^{-1} + 1.311z^{-2} + 1.337z^{-3} + 0.9z^{-4} \end{aligned}$$

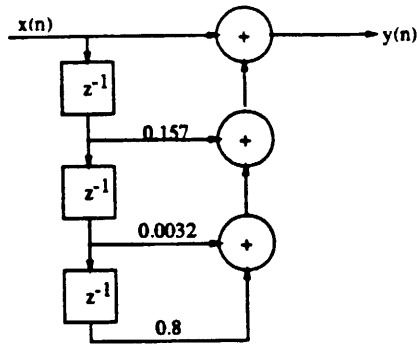

Figure 7.17:

(b) Refer to fig 7.20

7.22

(a)

From (7.3.38) we have

$$y(n) = -k_1(1 + k_2)y(n-1) - k_2y(n-2) + x(n)$$

$$\text{But, } y(n) = 2r\cos\omega_0 y(n-1) - r^2 y(n-2) + x(n)$$

$$\text{Hence, } k_2 = r^2$$

$$\text{and, } k_1(1 + k_2) = -2r\cos\omega_0$$

$$k_1 + \frac{2r\cos\omega_0}{1 + r^2}$$

Refer to fig 7.21

(b) When $r = 1$, the system becomes an oscillator.

7.23

$$\begin{aligned} H(z) &= \frac{1 - 0.8z^{-1} + 0.15z^{-2}}{1 + 0.1z^{-1} - 0.72z^{-2}} \\ &= \frac{B(z)}{A(z)} \end{aligned}$$

For the all-pole system $\frac{1}{A(z)}$, we have

$$k_1(1 + k_2) = 0.1$$

$$k_2 = -0.72$$

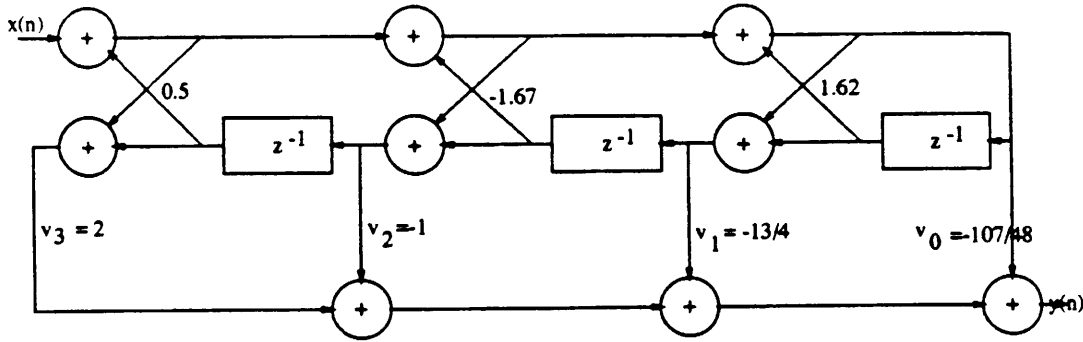

Figure 7.18:

$$\Rightarrow k_1 = 0.357$$

$$k_2 = 0.72$$

$$\text{For the all-zero system, } C_2(z) = 1 - 0.8z^{-1} + 0.15z^{-2}$$

$$A_2(z) = 1 - 0.8z^{-1} + 0.15z^{-2}$$

$$B_2(z) = 0.15 - 0.8z^{-1} + z^{-2}$$

$$k_2 = 0.15$$

$$A_1(z) = \frac{A_2(z) - k_2 B_2(z)}{1 - k_2^2}$$

$$= 1 - 0.696z^{-1}$$

$$B_1(z) = -0.696 + z^{-1}$$

$$k_1 = -0.696$$

$$A_0(z) = B_0(z) = 1$$

$$C_2(z) = \sum_{m=0}^2 v_m B_m(z)$$

$$= v_0 + v_1 B_1(z) + v_2 B_2(z)$$

$$= 1 - 0.8z^{-1} + 0.15z^{-2}$$

The solution is:

$$v_2 = 0.15$$

$$v_1 - 0.18v_2 = -0.8$$

$$v_0 - 0.696v_1 + 0.15v_2 = 1$$

$$\Rightarrow v_0 = 1.5$$

$$v_1 = -0.68$$

$$v_2 = 0.15$$

Thus the lattice-ladder structure is: Refer to fig 7.22

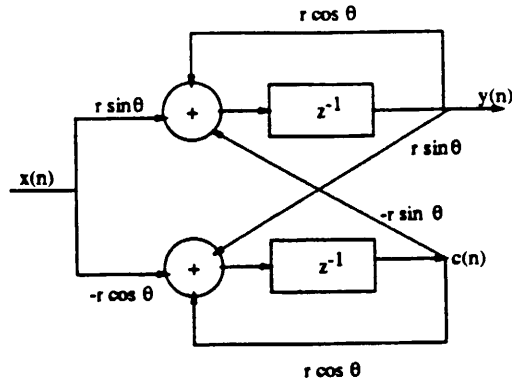

Figure 7.19:

7.24

$$y(n) = \sum_{k=0}^M b_k x(n-k)$$

$$\text{Let } v_i(n+1) = v_{i+1}(n), \quad i = 1, 2, \dots, M-1$$

$$v_M(n+1) = x(n)$$

$$\text{Then, } y(n) = b_0 x(n) + \sum_{i=1}^M b_i v_{M+1-i}(n)$$

Then

$$\begin{bmatrix} v_1(n+1) \\ v_2(n+1) \\ \vdots \\ v_{M-1}(n+1) \\ v_M(n+1) \end{bmatrix} = \begin{bmatrix} 0 & 1 & 0 & 0 & \dots & 0 \\ 0 & 0 & 1 & 0 & \dots & 0 \\ \vdots & \vdots & \vdots & \ddots & \ddots & 0 \\ \vdots & \vdots & 0 & & & 1 \\ 0 & \dots & \dots & \dots & \dots & 0 \end{bmatrix} \begin{bmatrix} v_1(n) \\ v_2(n) \\ \vdots \\ v_{M-1}(n) \\ v_M(n) \end{bmatrix} + \begin{bmatrix} 0 \\ 0 \\ \vdots \\ 0 \\ 1 \end{bmatrix} x(n)$$

$$y(n) = [b_M \quad b_{M-1} \quad \dots \quad b_1] \begin{bmatrix} v_1(n) \\ v_2(n) \\ \vdots \\ v_M(n) \end{bmatrix} + b_0 x(n)$$

General representation:

$$\underline{v}(n+1) = \underline{F}\underline{V}(n) + \underline{g}x(n)$$

$$y(n) = \underline{g}^t \underline{V}(n) + b_0 x(n)$$

The general state-space realization for this system is shown in figure 7.36 where $d = b_0$.

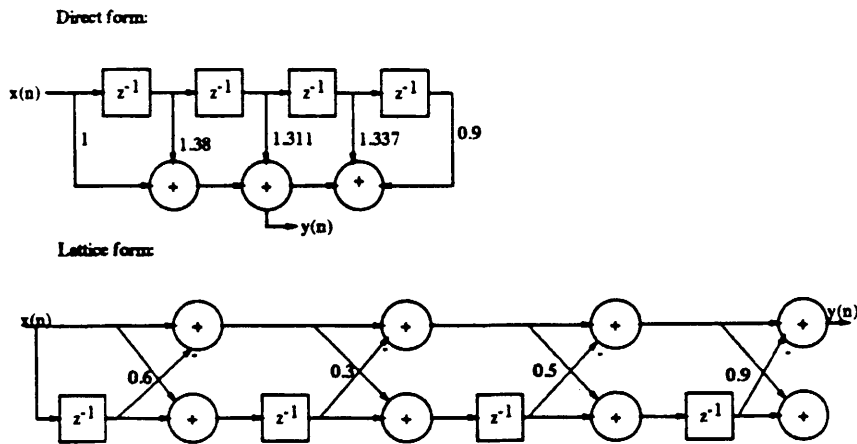

Figure 7.20:

7.25

$$\begin{aligned}
 y(n) &= y(n-1) + 0.11y(n-2) + x(n) \\
 a_1 &= -1 \\
 a_2 &= -0.11 \\
 b_0 &= 1
 \end{aligned}$$

Type 1 representation:

$$\underline{F} = \begin{bmatrix} 0 & 1 \\ 0.11 & 1 \end{bmatrix}, \quad \underline{q} = \begin{bmatrix} 0 \\ 1 \end{bmatrix}, \quad \underline{g} = \begin{bmatrix} 0.11 \\ 1 \end{bmatrix}, \quad d = 1$$

Type 2 representation:

$$\underline{F} = \begin{bmatrix} 0 & 0.11 \\ 1 & 1 \end{bmatrix}, \quad \underline{q} = \begin{bmatrix} 0.11 \\ 1 \end{bmatrix}, \quad \underline{g} = \begin{bmatrix} 0 \\ 1 \end{bmatrix}, \quad d = 1$$

Refer to fig 7.23

7.26

$$\begin{aligned}
 y(n) &= y(n-1) + y(n-2) + x(n) \\
 a_1 = a_2 &= -1 \\
 b_0 &= 1
 \end{aligned}$$

Type 1 representation:

$$\underline{F} = \begin{bmatrix} 0 & 1 \\ 1 & 1 \end{bmatrix}, \quad \underline{q} = \begin{bmatrix} 0 \\ 1 \end{bmatrix}, \quad \underline{g} = \begin{bmatrix} 1 \\ 1 \end{bmatrix}, \quad d = 1$$

Type 2 representation:

$$\underline{F} = \begin{bmatrix} 0 & 1 \\ 1 & 1 \end{bmatrix}, \quad \underline{q} = \begin{bmatrix} 1 \\ 1 \end{bmatrix}, \quad \underline{g} = \begin{bmatrix} 0 \\ 1 \end{bmatrix}, \quad d = 1$$

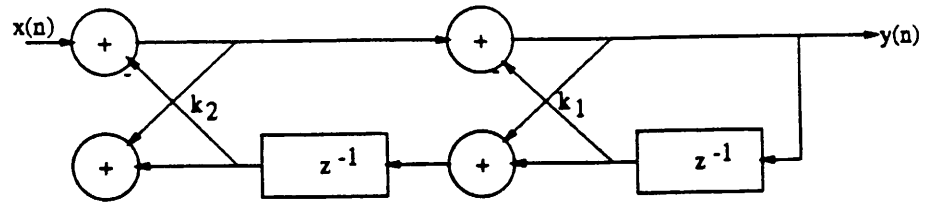

Figure 7.21:

Diagonal form (see example 7.5.2)

$$\hat{F} = \begin{bmatrix} \frac{1+\sqrt{5}}{2} & 0 \\ 0 & \frac{1-\sqrt{5}}{2} \end{bmatrix}, \quad \underline{q} = \begin{bmatrix} \frac{1}{\sqrt{5}} \\ -\frac{1}{\sqrt{5}} \end{bmatrix}, \quad \underline{g} = \begin{bmatrix} \frac{3+\sqrt{5}}{2} \\ \frac{3-\sqrt{5}}{2} \end{bmatrix}, \quad d = 1$$

7.27

$$\begin{bmatrix} v_1(n+1) \\ v_2(n+1) \end{bmatrix} = \begin{bmatrix} 0 & 0.11 \\ 1 & 1 \end{bmatrix} \begin{bmatrix} v_1(n) \\ v_2(n) \end{bmatrix} + \begin{bmatrix} 0.11 \\ 0 \end{bmatrix} x(n)$$

$$y(n) = \begin{bmatrix} 0 & 1 \end{bmatrix} \begin{bmatrix} v_1(n) \\ v_2(n) \end{bmatrix} + x(n)$$

$$zV_1(z) = 0.11V_2(z) + 0.11X(z)$$

$$zV_2(z) = V_1(z) + V_2(z) + X(z)$$

$$Y(z) = V_2(z) + X(z)$$

$$\Rightarrow H(z) = \frac{Y(z)}{X(z)}$$

$$= \frac{1}{1 - z^{-1} - 0.11z^{-2}}$$

$$= \frac{\frac{11}{12}}{1 - 1.1z^{-1}} + \frac{\frac{1}{12}}{1 + 0.1z^{-1}}$$

$$h(n) = \left[\frac{11}{12}(1.1)^n + \frac{1}{12}(-0.1)^n \right] u(n)$$

7.28

$$\underline{v}(n+1) = \begin{bmatrix} \alpha_1 & -\alpha_2 \\ \alpha_2 & \alpha_1 \end{bmatrix} \underline{v}(n) + \begin{bmatrix} q_1 \\ q_2 \end{bmatrix} x(n)$$

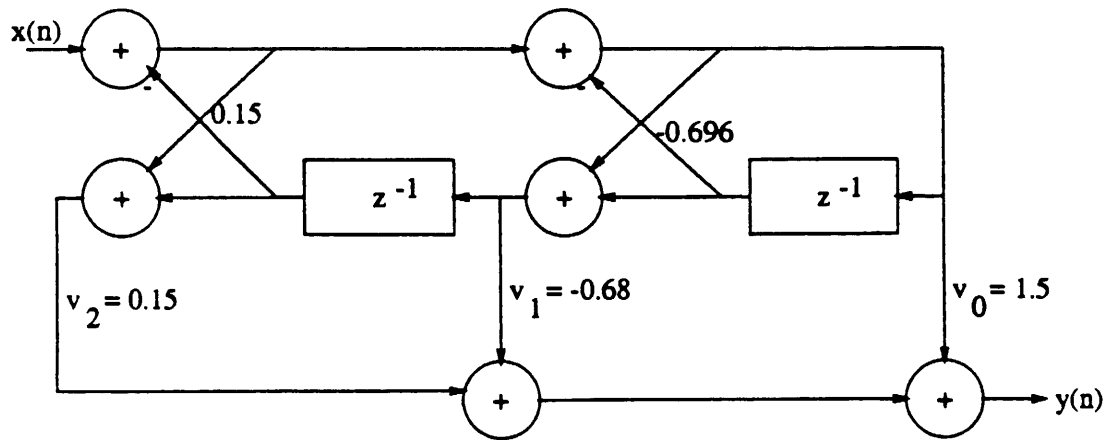

Figure 7.22:

$$|\lambda \underline{I} - \underline{A}| = \begin{vmatrix} \lambda - \alpha_1 & \alpha_2 \\ -\alpha_2 & \lambda - \alpha_1 \end{vmatrix} = (\lambda - \alpha_1)^2 - (\alpha_2)^2 = 0$$

$$(\lambda - \alpha_1)^2 = (\alpha_2)^2 \Rightarrow \lambda = \alpha_1 \pm j\alpha_2$$

7.29

Refer to fig 7.24 To obtain the transpose structure, we reverse the directions of all branch transmittances and interchange the input and output. Thus we obtain the structure shown below:
Refer to fig 7.25

7.30

(a) $H(z) = \frac{1 - \sqrt{2}z^{-1} + 0.25z^{-2}}{1 - 0.8z^{-1} + 0.64z^{-2}}$. Refer to fig 7.26
(b)

$$a_1 = -0.8$$

$$a_2 = 0.64$$

$$b_0 = 1$$

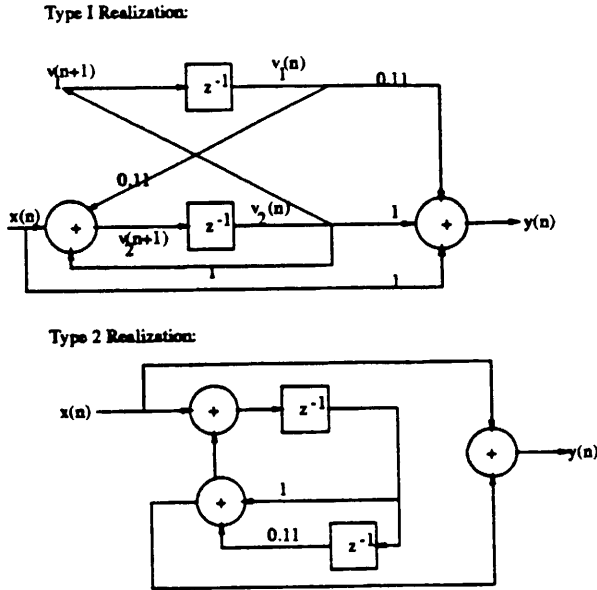

Figure 7.23:

$$b_1 = -\frac{\sqrt{2}}{2}$$

$$b_2 = 0.25$$

Type 1 representation:

$$\underline{F} = \begin{bmatrix} 0 & 1 \\ -0.64 & 0.8 \end{bmatrix}, \quad \underline{q} = \begin{bmatrix} 0 \\ 1 \end{bmatrix}, \quad \underline{g} = \begin{bmatrix} -0.39 \\ 0.8 - \frac{\sqrt{2}}{2} \end{bmatrix}, \quad d = 1$$

Type 2 representation:

$$\underline{F} = \begin{bmatrix} 0 & 0.64 \\ 1 & 0.8 \end{bmatrix}, \quad \underline{q} = \begin{bmatrix} -0.39 \\ 0.8 - \frac{\sqrt{2}}{2} \end{bmatrix}, \quad \underline{g} = \begin{bmatrix} 0 \\ 1 \end{bmatrix}, \quad d = 1$$

Refer to fig 7.27

(c)

$$H(z) = \frac{1 - 0.707z^{-1} + 0.25z^{-2}}{1 - 0.8z^{-1} + 0.64z^{-2}}$$

$$= \frac{25}{64} + \frac{0.609(1 - \cos(\frac{\pi}{3})z^{-1})}{1 - 2(0.8\cos\frac{\pi}{3})z^{-1} + (0.8)^2z^{-2}}$$

$$+ \frac{-0.208\sin(\frac{\pi}{3})z^{-1}}{1 - 2(0.8\cos\frac{\pi}{3})z^{-1} + (0.8)^2z^{-2}}$$

$$\text{Therefore, } h(n) = 0.391\delta(n) + [0.609(0.8)^n\cos(\frac{\pi}{3}n) - 0.208(0.8)^n\sin(\frac{\pi}{3}n)]u(n)$$

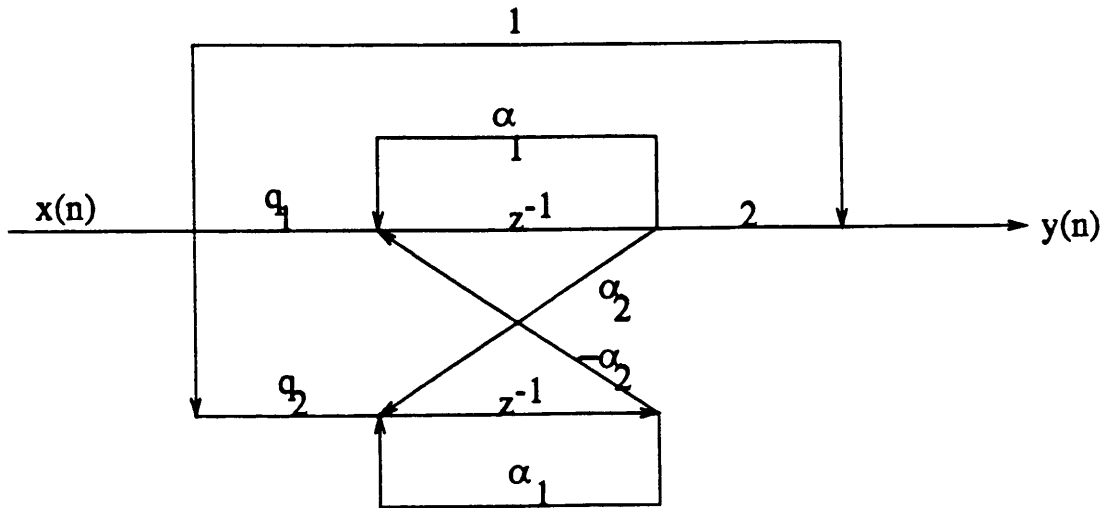

Figure 7.24: State-space realization of coupled-form structure

From the state-space representation, we have

$$h(n) = \begin{bmatrix} -0.39 & 0.8 - \frac{\sqrt{2}}{2} \end{bmatrix} \begin{bmatrix} 0 & 1 \\ 0.64 & 0.8 \end{bmatrix}^{n-1} \begin{bmatrix} 0 \\ 1 \end{bmatrix} u(n-1) + \delta(n)$$

(d) Coupled-form state space realization:

$$H(z) = 1 + \frac{0.0464 + j0.255}{z - (0.4 + j0.4\sqrt{3})} + \frac{0.0464 - j0.255}{z - (0.4 - j0.4\sqrt{3})}$$

Hence, $A_k = 0.0464 + j0.255$ $q_{k1} = 0.0464$ $q_{k2} = 0.255$
 $p_k = 0.4 + j0.4\sqrt{3}$ $a_{k1} = 0.4$ $a_{k2} = 0.4\sqrt{3}$

Therefore,

$$F = \begin{bmatrix} 0.4 & -0.4\sqrt{3} \\ -0.4\sqrt{3} & 0.4 \end{bmatrix}, \quad \underline{q} = \begin{bmatrix} 0.0464 \\ 0.255 \end{bmatrix}, \quad \underline{g} = \begin{bmatrix} 2 \\ 0 \end{bmatrix}, \quad d = 1$$

(e)

(a) $H(z) = \frac{1 - \frac{\sqrt{2}}{2}z^{-1} + 0.25z^{-2}}{1 - \frac{1}{3}\sqrt{2}z^{-1} + 0.64z^{-2}}$ Refer to fig 7.28

(b)

$$F = \begin{bmatrix} 0 & 1 \\ -0.64 & 0.8\sqrt{2} \end{bmatrix}, \quad \underline{q} = \begin{bmatrix} 0 \\ 1 \end{bmatrix}, \quad \underline{g} = \begin{bmatrix} -0.39 \\ 0.3\sqrt{2} \end{bmatrix}, \quad d = 1$$

(c)

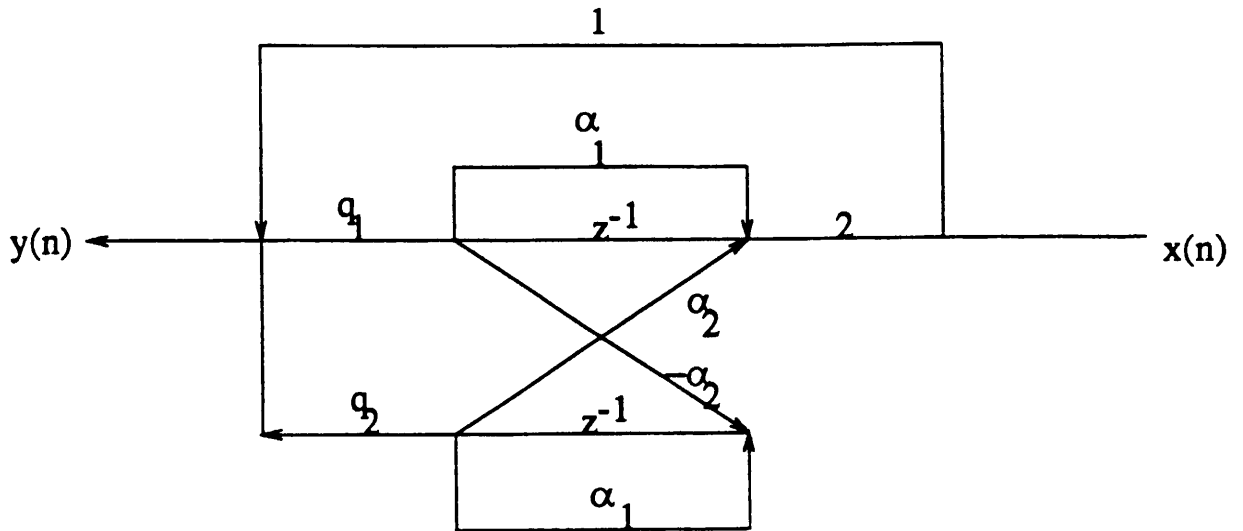

Figure 7.25:

$$h(n) = \begin{bmatrix} -0.39 & 0.3\sqrt{2} \end{bmatrix} \begin{bmatrix} 0 & 1 \\ -0.64 & 0.8\sqrt{2} \end{bmatrix}^{n-1} \begin{bmatrix} 0 \\ 1 \end{bmatrix} u(n-1) + \delta(n)$$

(d)

$$F = \begin{bmatrix} 0.4\sqrt{2} & -0.4\sqrt{2} \\ 0.4\sqrt{2} & 0.4\sqrt{2} \end{bmatrix}, \quad q = \begin{bmatrix} 0.212 \\ 0.133 \end{bmatrix}, \quad g = \begin{bmatrix} 2 \\ 0 \end{bmatrix}, \quad d = 1$$

7.31

$$(a) H(z) = \frac{1+z^{-1}}{1-z^{-1}} \cdot \frac{1}{1-0.8\sqrt{2}z^{-1}+0.64z^{-2}}$$

$$(b) H(z) = \frac{2.31}{1-\frac{1}{2}z^{-1}} + \frac{-1.31+2.96z^{-1}}{1-0.8\sqrt{2}z^{-1}+0.64z^{-2}} \quad \text{Refer to fig 7.29}$$

(c)

$$\begin{aligned} H(z) &= \frac{1+z^{-1}}{1-1.63z^{-1}+1.21z^{-2}-0.32z^{-3}} \\ a_1 &= -1.63 \\ a_2 &= 1.21 \\ a_3 &= -0.32 \\ b_0 &= 1 \\ b_1 &= 1 \end{aligned}$$

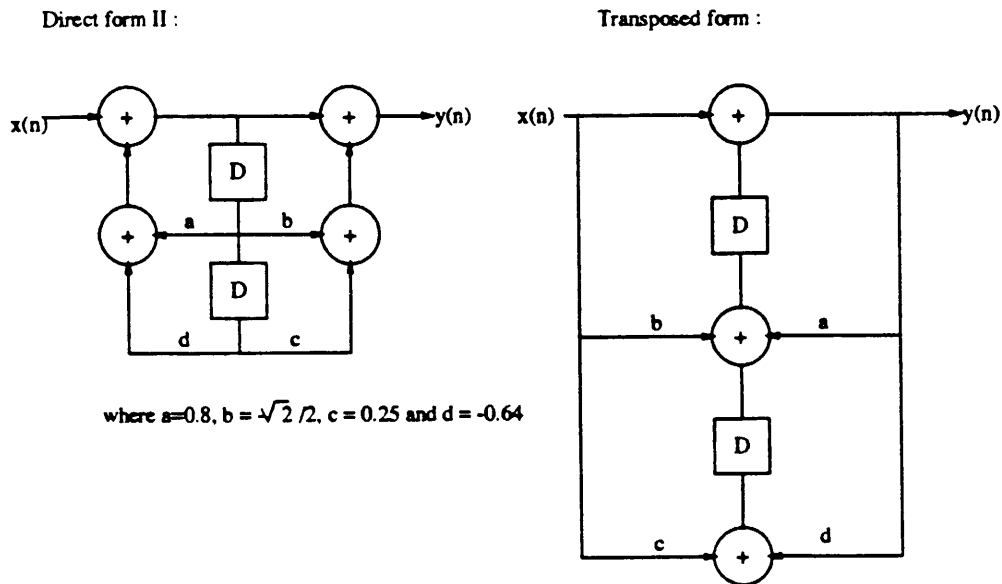

Figure 7.26:

Type 1 representation:

$$\underline{F} = \begin{bmatrix} 0 & 1 & 0 \\ 0 & 0 & 1 \\ 0.32 & -1.21 & 1.63 \end{bmatrix}, \quad \underline{q} = \begin{bmatrix} 0 \\ 0 \\ 1 \end{bmatrix}, \quad \underline{g} = \begin{bmatrix} 0.32 \\ -1.21 \\ 2.63 \end{bmatrix}, \quad d = 1$$

Type 2 representation:

$$\underline{F} = \begin{bmatrix} 0 & 0 & 0.32 \\ 1 & 0 & -1.21 \\ 0 & 1 & 1.63 \end{bmatrix}, \quad \underline{q} = \begin{bmatrix} 0.32 \\ -1.21 \\ 2.63 \end{bmatrix}, \quad \underline{g} = \begin{bmatrix} 0 \\ 0 \\ 1 \end{bmatrix}, \quad d = 1$$

7.32

$$H(z) = 0.5H_1(z)H_2(z)$$

where $H_1(z) = 1 + 0.4z^{-1} - 1.2z^{-2} + 2z^{-3}$

$$H_2(z) = \frac{1}{1 - 0.6z^{-1} + 0.2z^{-2} + 0.5z^{-3}}$$

$H(z)$ can be realized as a cascade of two lattice filters (an all-zero lattice and an all-pole lattice) or as a lattice-ladder filter. Let us choose a cascade configuration:

For $H_1(z)$ we have

$$A_3(z) = 1 + 0.4z^{-1} - 1.2z^{-2} + 2z^{-3}$$

$$B_3(z) = 2 - 1.2z^{-1} + 0.4z^{-2} + z^{-3}$$

Type 1 Realization:

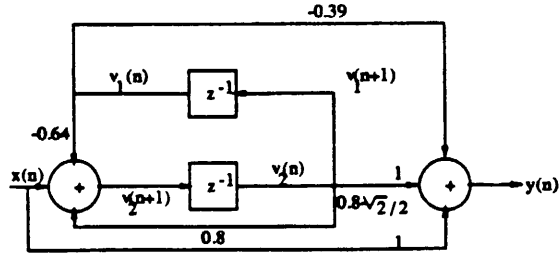

Type 2 Realization:

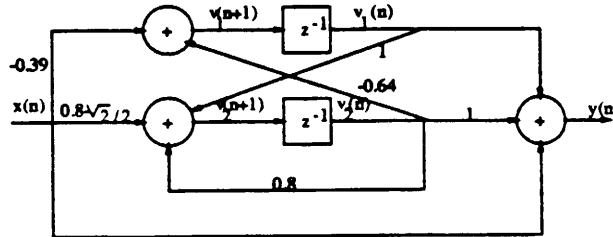

Figure 7.27:

$$\begin{aligned}
 k_3 &= 2 \\
 A_2(z) &= \frac{A_3(z) - k_3 B_3(z)}{1 - k_3^2} \\
 &= 1 - \frac{14}{15}z^{-1} + \frac{2}{3}z^{-2} \\
 B_2(z) &= \frac{2}{3} - \frac{14}{15}z^{-1} + z^{-2} \\
 k_2 &= \frac{2}{3} \\
 A_1(z) &= \frac{A_2(z) - k_2 B_2(z)}{1 - k_2^2} \\
 &= 1 - \frac{14}{15}z^{-1} \\
 k_1 &= -\frac{14}{15}
 \end{aligned}$$

For $H_2(z)$ we have

$$\begin{aligned}
 F_3(z) &= 1 - 0.6z^{-1} + 0.2z^{-2} + 0.5z^{-3} \\
 G_3(z) &= 0.5 + 0.2z^{-1} - 0.6z^{-2} + z^{-3} \\
 k_3 &= 0.5 \\
 F_2(z) &= \frac{F_3(z) - k_3 G_3(z)}{1 - k_3^2} \\
 &= 1 - \frac{14}{15}z^{-1} + \frac{2}{3}z^{-2}
 \end{aligned}$$

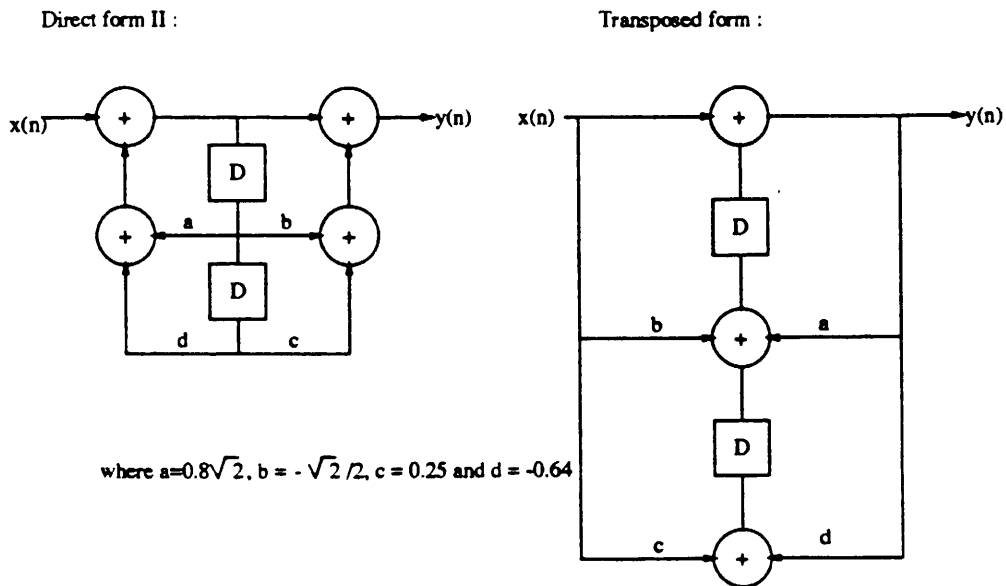

Figure 7.28:

$$G_2(z) = \frac{2}{3} - \frac{14}{15}z^{-1} + z^{-2}$$

$$k_2 = \frac{2}{3}$$

$$F_1(z) = \frac{F_2(z) - k_2 G_2(z)}{1 - k_2^2}$$

$$= 1 - \frac{14}{25}z^{-1}$$

$$k_1 = -\frac{14}{25}$$

The all-zero lattice has reflection coefficients

$$k_3 = 2$$

$$k_2 = \frac{2}{3}$$

$$k_1 = -\frac{14}{15}$$

The all-pole lattice has reflection coefficients

$$k_3 = \frac{1}{2}$$

$$k_2 = \frac{2}{3}$$

$$k_1 = -\frac{14}{25}$$

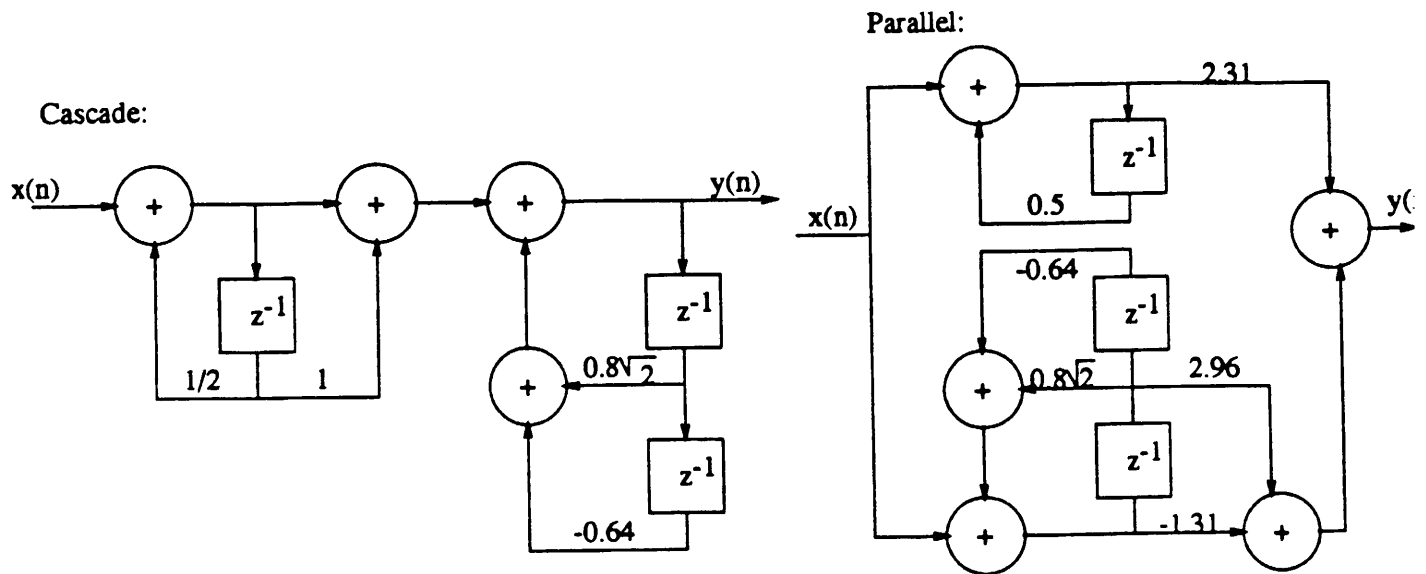

Figure 7.29:

Refer to fig 7.30

7.33

(a)

$$|\lambda \underline{I} - \underline{E}| = \begin{vmatrix} \lambda & -1 \\ 0.81 & \lambda - 1 \end{vmatrix} = \lambda(\lambda - 1) + 0.81 = 0$$

$$\lambda^2 - \lambda + 0.81 = 0 \Rightarrow \lambda_{1,2} = 0.5 \pm j1.50$$

(b)

$$\Phi(z) = z(z\underline{I} - \underline{E})^{-1} = z \frac{1}{z^2 - z + 0.81} \begin{bmatrix} z - 1 & -0.81 \\ 1 & z \end{bmatrix}$$

$$\Phi(n) = \begin{bmatrix} \phi_{11}(n) & \phi_{12}(n) \\ \phi_{21}(n) & \phi_{22}(n) \end{bmatrix}$$

$$\Phi_{11}(z) = \frac{z^2 - z}{z^2 - z + 0.81}$$

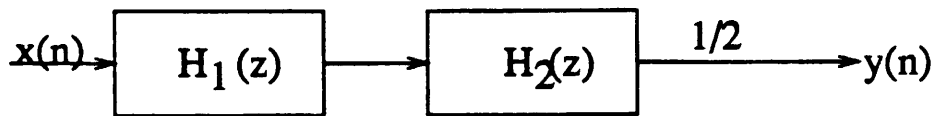

Figure 7.30:

$$\begin{aligned}
 &= \frac{1 - z^{-1}}{1 - z^{-1} + 0.81z^{-2}} \\
 \phi_{11}(n) &= (0.9)^n \left[\cos(0.98n) - \frac{2}{3} \sin(0.98n) \right] u(n) \\
 \Phi_{12}(z) &= \frac{-0.8z}{z^2 - z + 0.81} \\
 \phi_{12}(n) &= \frac{4}{3} (0.9)^n \sin(0.98n) u(n) \\
 \Phi_{21}(z) &= \frac{z}{z^2 - z + 0.81} \\
 \phi_{21}(n) &= -1.08 (0.9)^n \sin(0.98n) u(n) \\
 \Phi_{22}(z) &= \frac{z^2}{z^2 - z + 0.81} \\
 \phi_{22}(n) &= (0.9)^n \left[\cos(0.98n) + \frac{2}{3} \sin(0.98n) \right] u(n)
 \end{aligned}$$

(c)

$$\begin{aligned}
 a_1 &= -1 \\
 a_2 &= 0.81 \\
 b_0 &= 1 \\
 b_1 &= 0 \\
 b_2 &= -1 \\
 H(z) &= \frac{1 - z^{-2}}{1 - z^{-1} + 0.81z^{-2}} \\
 h(n) &= (0.9)^n \cos(0.98n) u(n) + [-0.5 \cos(0.98(n-1)) - \sin(0.98(n-1))] (0.9)^{n-1} u(n-1)
 \end{aligned}$$

(d) For the zero-input response $y_{zi}(n)$ we have

$$z[V(z) - v(0)] = FV(z)$$

$$\begin{aligned} \underline{V}(z) &= (zI - \underline{F})^{-1} z\underline{V}(0) \\ Y_{zi}(z) &= \underline{g}\underline{V}(z) = \underline{g}(zI - \underline{F})^{-1} z\underline{V}(0) \\ y_{zi}(n) &= z^{-1} \{Y_{zi}(z)\} \end{aligned}$$

For the zero-state response $y_{zs}(n)$ we have

$$\begin{aligned} z\underline{V}(z) &= \underline{F}\underline{V}(z) + \underline{g}X(z) \\ Y_{zs}(z) &= \underline{g}\underline{V}(z) + X(z) \\ Y_{zs}(z) &= \underline{g}(zI - \underline{F})^{-1} \underline{g}X(z) + X(z), \\ X(z) &= \frac{z^{-1}}{1 - z^{-1}} \\ y_{zs}(n) &= z^{-1} \{Y_{zs}(z)\} \\ y(n) &= y_{zi}(n) + y_{zs}(n) \\ &= (0.9)^n [2\cos(0.98n) + 1.1\sin(0.98n)] u(n) \end{aligned}$$

(e) Refer to fig 7.31

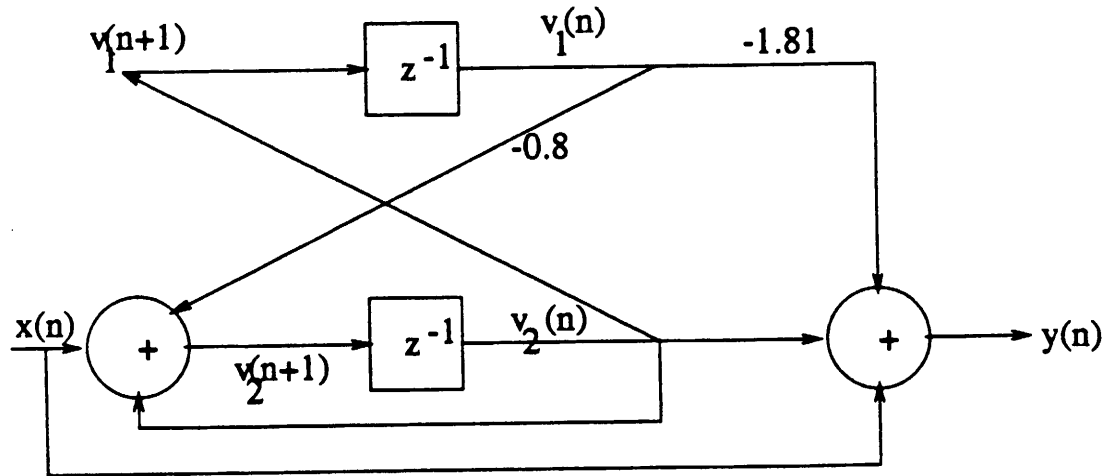

Figure 7.31:

7.34

Using the same method as in 7.33 we obtain the following answers:

(a)

$$C(z) = z^2 + 3z + 2$$

roots: $z = -2, -1$

(b)

$$\Phi(n) = \begin{bmatrix} \phi_{11}(n) & \phi_{12}(n) \\ \phi_{21}(n) & \phi_{22}(n) \end{bmatrix}$$

$$\phi_{11}(n) = [-1(-2)^n + 2(-1)^n]u(n)$$

$$\phi_{12}(n) = [-1(-2)^n + 2(-1)^n]u(n)$$

$$\phi_{21}(n) = -2\phi_{12}(n)$$

$$\phi_{22}(n) = [2(-2)^n - (-1)^n]u(n)$$

(c)

$$H(z) = \frac{1}{z^2 + 3z + 2}$$

$$h(n) = [-(-2)^{n-1} + (-1)^n] u(n-1)$$

(d)

$$y(n) = y_{zi}(n) + y_{zs}(n)$$

$$h(n) = [-(-2)^n + (-1)^n] u(n) + [\frac{1}{3}(-2)^n - \frac{1}{2}(-1)^n + \frac{1}{6}] u(n)$$

(e) Refer to fig 7.32

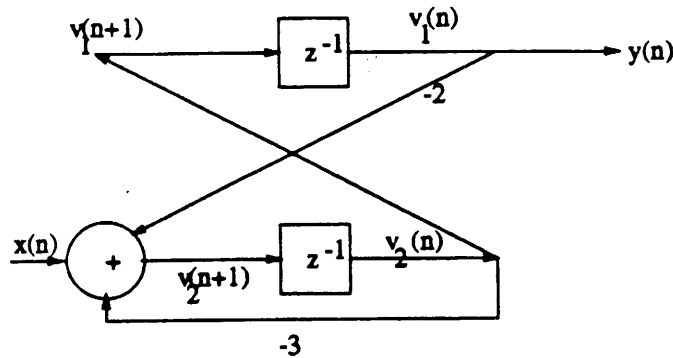

Figure 7.32:

7.35

Using the same method for the solution as in 7.33, we obtain the following answers:

(a)

$$C(z) = z^2 + 0.6z - 0.07$$

roots: $z = 0.1, -0.7$

(b)

$$\phi_{11}(n) = \phi_{22}(n) = \left[\frac{1}{2}(0.1)^n + \frac{1}{2}(-0.7)^n \right] u(n)$$

$$\phi_{12}(n) = \phi_{21}(n) = \left[\frac{1}{2}(0.1)^n - \frac{1}{2}(-0.7)^n \right] u(n)$$

(c)

$$H(z) = \frac{1}{z - 0.1} + 1$$

$$h(n) = \delta(n) + (0.1)^{n-1} u(n-1)$$

(d) $y(n] = (0.1)^n u(n) + \left[\frac{19}{9} - \frac{10}{9}(0.1)^n \right] u(n)$ Refer to fig 7.33

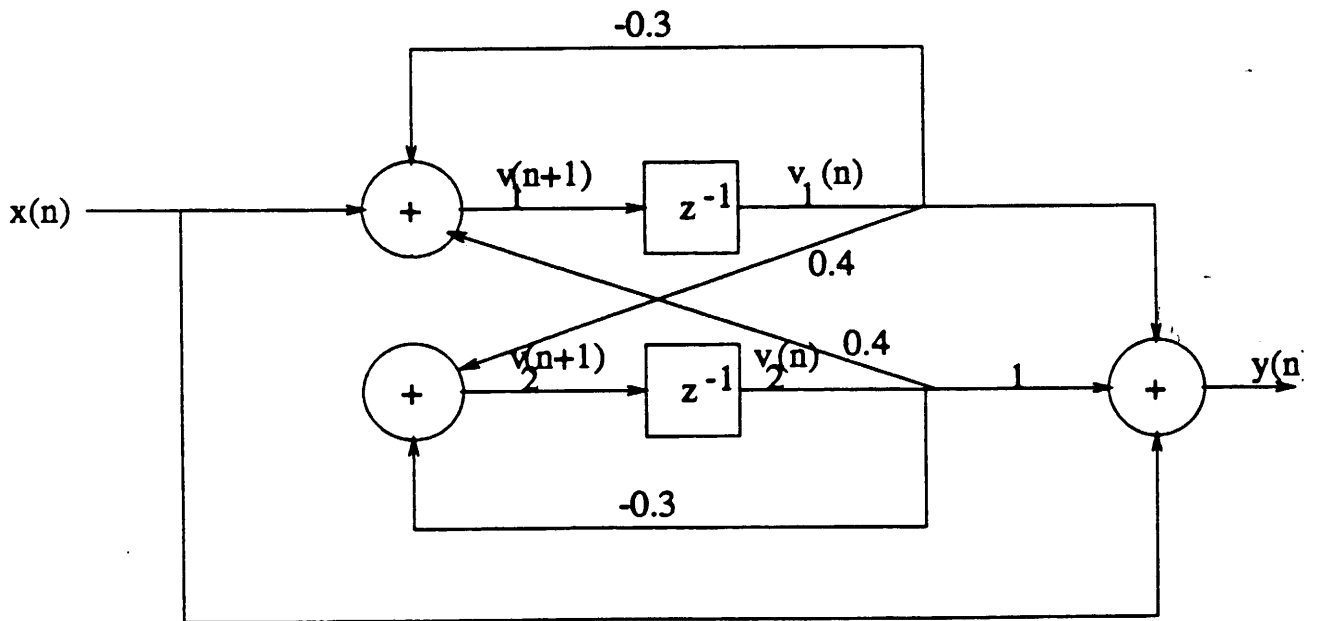

Figure 7.33:

7.36

(a)

$$H(z) = \frac{1 + z^{-1}}{1 - 0.9z^{-1} + 0.08z^{-2}}$$

$$a_1 = -0.9$$

$$a_2 = 0.08$$

$$\begin{aligned} b_0 &= 1 \\ b_1 &= 1 \end{aligned}$$

Type 1 representation:

$$\underline{F} = \begin{bmatrix} 0 & 1 \\ -0.08 & 0.9 \end{bmatrix}, \quad \underline{q} = \begin{bmatrix} 0 \\ 1 \end{bmatrix}, \quad \underline{g} = \begin{bmatrix} -0.08 \\ 1.9 \end{bmatrix}, \quad d = 1$$

Type 2 representation:

$$\underline{F} = \begin{bmatrix} 0 & -0.08 \\ 1 & 0.9 \end{bmatrix}, \quad \underline{q} = \begin{bmatrix} -0.08 \\ 1.9 \end{bmatrix}, \quad \underline{g} = \begin{bmatrix} 0 \\ 1 \end{bmatrix}, \quad d = 1$$

(b) Refer to fig 7.34

Parallel:

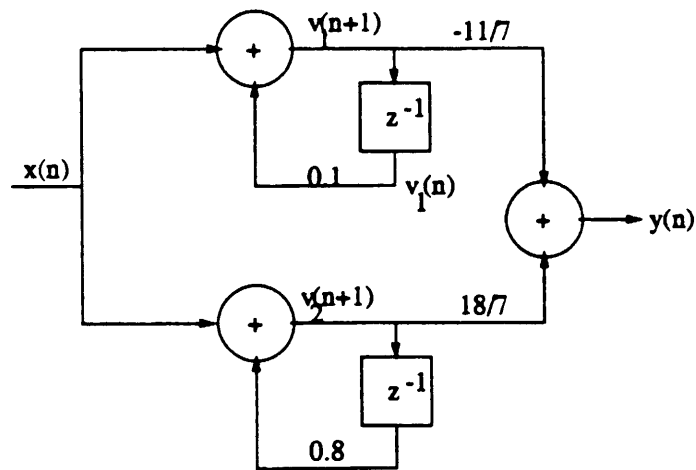

Figure 7.34:

$$\begin{aligned} H(z) &= \frac{1 + z^{-1}}{(1 - 0.1z^{-1})(1 - 0.8z^{-1})} \\ &= \frac{-\frac{11}{7}}{1 - 0.1z^{-1}} + \frac{\frac{18}{7}}{1 - 0.8z^{-1}} \end{aligned}$$

$$\underline{F} = \begin{bmatrix} 0.1 & 0 \\ 0 & 0.8 \end{bmatrix}, \quad \underline{q} = \begin{bmatrix} -\frac{11}{7} \\ \frac{18}{7} \end{bmatrix}, \quad \underline{g} = \begin{bmatrix} 0.1 \\ 0.8 \end{bmatrix}, \quad d = 1$$

Cascade:

$$H(z) = \frac{1 + z^{-1}}{(1 - 0.8z^{-1})(1 - 0.1z^{-1})}$$

$$\begin{aligned}
&= H_1(z)H_2(z) \\
\underline{F}_1 &= [0.8], \quad \underline{q}_1 = [1], \quad \underline{g}_1 = [1.8], \quad d_1 = 1 \\
\underline{F}_2 &= [0.1], \quad \underline{q}_2 = [1], \quad \underline{g}_2 = [0.1], \quad d_2 = 1
\end{aligned}$$

(c) Method 1:

$$\begin{aligned}
H(z) &= \frac{-\frac{11}{7}}{1-0.1z^{-1}} + \frac{\frac{18}{7}}{1-0.8z^{-1}} \\
h(n) &= \left[-\frac{11}{7}(0.1)^n + \frac{18}{7}(0.8)^n \right] u(n)
\end{aligned}$$

Method 2: From (a) we have,

$$\begin{aligned}
\underline{v}(n+1) &= \underline{F}\underline{v}(n) + \underline{q}x(n) \\
\underline{y}(n) &= \underline{v}^t\underline{v}(n) + dx(n) \\
Y(z) &= \underline{g}^t(z\underline{I} - \underline{F})^{-1}\underline{q}X(z) + dX(z), \quad X(z) = 1 \\
\text{Hence, } H(z) &= \underline{g}^t(z\underline{I} - \underline{F})^{-1}\underline{q} + d
\end{aligned}$$

$$\begin{aligned}
H(z) &= \begin{bmatrix} 0.08 \\ 1.9 \end{bmatrix}^t \begin{bmatrix} z & -1 \\ 0.08 & z-0.9 \end{bmatrix} \begin{bmatrix} 0 \\ 1 \end{bmatrix} + 1 \\
H(z) &= \frac{1+z^{-1}}{1-0.9z^{-1}+0.08z^{-2}}
\end{aligned}$$

which is the same system function as in (a).

7.37

$$(a) H(z) = \frac{1+\frac{1}{4}z^{-1}}{1-\frac{3}{4}z^{-1}+\frac{1}{8}z^{-2}}$$

$$(b) b_0 = 1, \quad b_1 = \frac{1}{3}, \quad a_1 = -\frac{3}{4}, \quad a_2 = \frac{1}{8}$$

$$\underline{F} = \begin{bmatrix} 0 & 1 \\ -\frac{1}{8} & \frac{3}{4} \end{bmatrix}, \quad \underline{q} = \begin{bmatrix} 0 \\ 1 \end{bmatrix}, \quad \underline{g} = \begin{bmatrix} -\frac{1}{8} \\ \frac{13}{12} \end{bmatrix}, \quad d = 1$$

(c)

$$\Phi(z) = z(z\underline{I} - \underline{F})^{-1} = \frac{z}{z^2 - \frac{3}{4}z + \frac{1}{8}} \begin{bmatrix} z - \frac{3}{4} & -\frac{1}{8} \\ 1 & 2 \end{bmatrix}$$

$$= \begin{bmatrix} \frac{1-\frac{1}{4}z^{-1}}{(1-\frac{1}{2}z^{-1})(1-\frac{1}{4}z^{-1})} & \frac{-\frac{1}{8}z^{-1}}{(1-\frac{1}{2}z^{-1})(1-\frac{1}{4}z^{-1})} \\ \frac{z^{-1}}{(1-\frac{1}{2}z^{-1})(1-\frac{1}{4}z^{-1})} & \frac{1}{(1-\frac{1}{2}z^{-1})(1-\frac{1}{4}z^{-1})} \end{bmatrix}$$

$$\underline{\phi}(n) = \begin{bmatrix} -(\frac{1}{2})^n u(n) + 2(\frac{1}{4})^n u(n) & 4(\frac{1}{2})^n u(n) - 4(\frac{1}{4})^n u(n) \\ -(\frac{1}{2})^{n+1} u(n) + \frac{1}{2}(\frac{1}{4})^n u(n) & 2(\frac{1}{2})^n u(n) - (\frac{1}{4})^n u(n) \end{bmatrix}$$

(d)

$$H(z) = \begin{bmatrix} -\frac{1}{8} & \frac{13}{12} \end{bmatrix} \begin{bmatrix} z & -1 \\ \frac{1}{8} & z - \frac{3}{4} \end{bmatrix} \begin{bmatrix} 0 \\ 1 \end{bmatrix} + 1$$

$$H(z) = \frac{1+\frac{1}{4}z^{-1}}{1-\frac{3}{4}z^{-1}+\frac{1}{8}z^{-2}}$$

(e) $\det(z\underline{I} - \underline{F}) = z^2 - \frac{3}{4}z + \frac{1}{8} = (z - \frac{1}{2})(z - \frac{1}{4}) = 0$. $z = \frac{1}{2}, \frac{1}{4}$ are both inside the unit circle. Hence, the system is stable.

7.38

$$H(z) = \underline{g}'(z\underline{I} - \underline{E})^{-1}\underline{q} + d$$

$$H(z) = \begin{bmatrix} 0 & 1 \end{bmatrix} \begin{bmatrix} z & -0.11 \\ -1 & z-1 \end{bmatrix} \begin{bmatrix} 0.11 \\ 1 \end{bmatrix} + 1$$

$$H(z) = \frac{1}{1 - z^{-1} - 0.11z^{-2}}$$

$$= \frac{\frac{11}{12}}{1 - 1.1z^{-1}} + \frac{\frac{1}{12}}{1 + 0.1z^{-1}}$$

$$\text{Therefore, } h(n) = \left[\frac{11}{12}(1.1)^n + \frac{1}{12}(-0.1)^n \right] u(n)$$

7.39

(a) Refer to fig 7.35

(b)

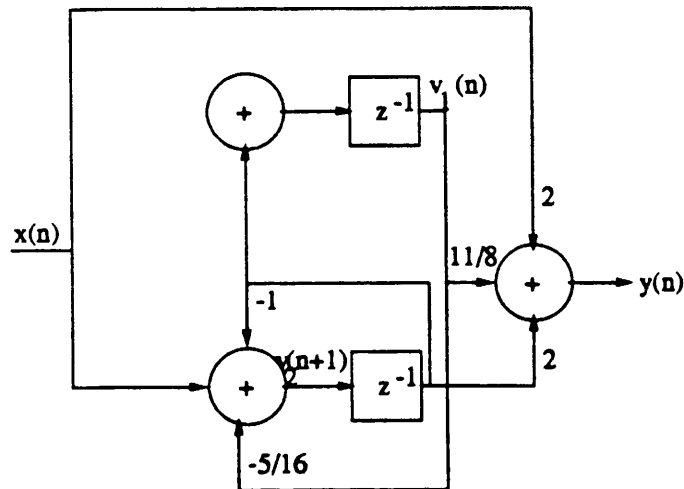

Figure 7.35:

$$\underline{v}(n+1) = \begin{bmatrix} 0 & 1 \\ -\frac{5}{16} & -1 \end{bmatrix} \underline{v}(n) + \begin{bmatrix} 0 \\ 1 \end{bmatrix} x(n)$$

$$\underline{v}(1) = \begin{bmatrix} 0 & 1 \\ -\frac{5}{16} & -1 \end{bmatrix} \underline{v}(0) + \begin{bmatrix} 0 \\ 1 \end{bmatrix} x(0) = \begin{bmatrix} 0 \\ 1 \end{bmatrix}$$

$$y(n) = \left[\frac{11}{18} 2\right] \underline{v}(n) + 2x(n)$$

$$h(0) = \left[\frac{11}{18} 2\right] \underline{v}(0) + 2x(0) = 2$$

$$h(1) = \left[\frac{11}{18} 2\right] \underline{v}(1) + 2x(1) = 2$$

proceeding in the same way, we obtain

$$h(2) = -\frac{5}{8}$$

$$h(3) = 0$$

$$h(4) = \frac{25}{128}$$

$$h(5) = -\frac{25}{128}$$

(c)

$$H(z) = \underline{g}^t(zI - E)^{-1} \underline{g} + d$$

$$= \frac{2 + 4z^{-1} + 2z^{-2}}{1 + z^{-1} + \frac{5}{16}z^{-2}}$$

Therefore, $y(n) = -y(n-1) - \frac{5}{16}y(n-2) + 2x(n) + 4x(n-1) + 2x(n-2)$

(d) For $x(n) = \delta(n)$, we obtain $y(0) = 2, y(1) = 2, y(2) = -\frac{5}{8}$, etc. These results check with (b)
 (e). Refer to fig 7.36

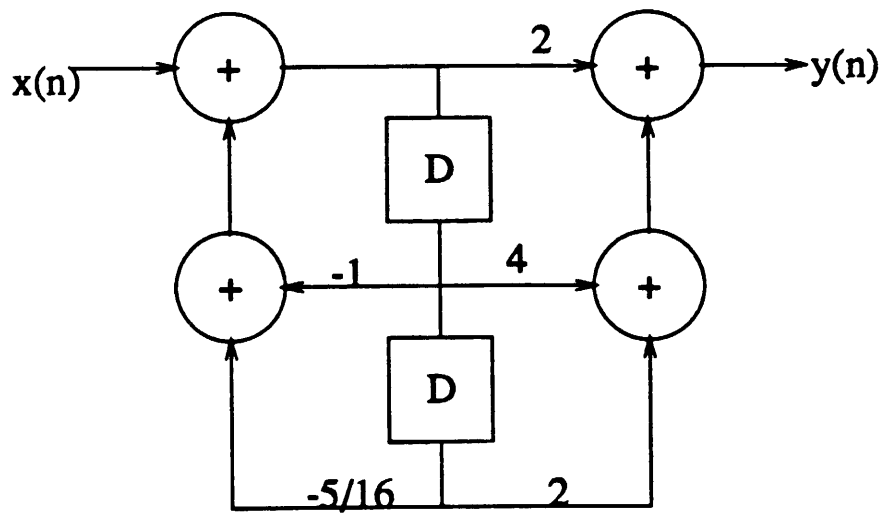

Figure 7.36:

7.40

(a) Refer to fig 7.37

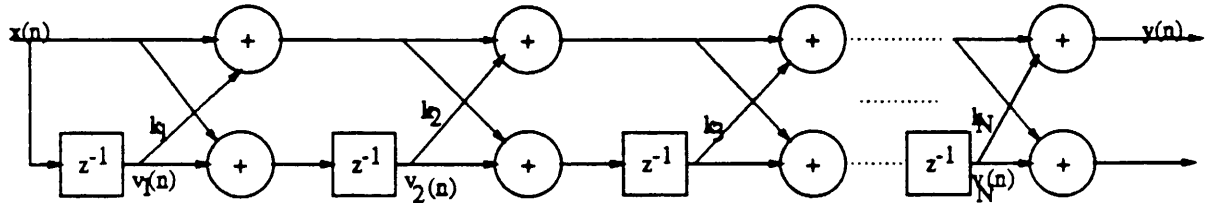

Figure 7.37: All-zero lattice

$$\begin{aligned}
 v_1(n+1) &= x(n) \\
 v_2(n+1) &= k_1 x(n) + v_1(n) \\
 v_3(n+1) &= k_2 x(n) + k_1 k_2 v_1(n) + v_2(n) \\
 &\vdots \\
 v_N(n+1) &= k_{N-1} x(n) + k_1 k_{N-1} v_1(n) + k_2 k_{N-1} v_2(n) + \dots + v_{N-1}(n) \\
 y(n) &= x(n) + k_1 v_1(n) + k_2 v_2(n) + \dots + k_N v_N(n)
 \end{aligned}$$

$$\underline{F} = \begin{bmatrix} 0 & 0 & \dots & 0 & 0 \\ 1 & 0 & \dots & 0 & 0 \\ k_1 k_2 & 1 & \ddots & 0 & \vdots \\ k_1 k_3 & k_2 k_3 & \ddots & \vdots & \vdots \\ \vdots & \vdots & \ddots & \vdots & \vdots \\ k_1 k_{N-1} & k_2 k_{N-1} & & 1 & 0 \end{bmatrix} \quad \underline{g} = \begin{bmatrix} 1 \\ k_1 \\ k_2 \\ \vdots \\ k_{N-1} \end{bmatrix}$$

$$\underline{g}^t = [k_1 \quad k_2 \quad \dots \quad k_N] \quad d = 1$$

(b) If we proceed as in (a) we obtain

$$\underline{F} = \begin{bmatrix} -k_1 & -k_2 & \dots & \dots & -k_N \\ 1 - k_1^2 & -k_2 & \dots & \dots & \vdots \\ 0 & 1 - k_2^2 & -k_3 & \dots & \vdots \\ \dots & \dots & \dots & \dots & \vdots \\ & & & 1 - k_{N-1}^2 & -k_N \end{bmatrix} \quad \underline{q} = \begin{bmatrix} 1 \\ k_1 \\ k_2 \\ \vdots \\ k_{N-1} \end{bmatrix}$$

$$\underline{g}^t = [-k_1 \quad -k_2 \quad \dots \quad -k_N] \quad d = 1$$

7.41

(a)

For positive numbers, range is

$$01.\underbrace{00\dots0}_{11}x2^{1001} - 01.\underbrace{11\dots1}_{11}x2^{0111}$$

$$\text{or } 7.8125x10^{-3} - 2.5596875x10^2$$

negative numbers

$$10.\underbrace{11\dots1}_{11}x2^{1001} - 10.\underbrace{00\dots0}_{11}x2^{0111}$$

$$\text{or } -7.8163x10^{-3} - -2.56x10^2$$

(b)

For positive numbers, range is

$$01.\underbrace{00\dots0}_{23}x2^{10000001} - 01.\underbrace{11\dots1}_{23}x2^{01111111}$$

$$\text{or } 5.8774717x10^{-39} - 3.4028234x10^{38}$$

negative numbers

$$10.\underbrace{11\dots1}_{23}x2^{10000001} - 10.\underbrace{00\dots0}_{23}x2^{01111111}$$

$$\text{or } -5.8774724x10^{-39} - -3.4028236x10^{38}$$

7.42

(a) Refer to fig 7.38

$$H_R(z) = (1 + a_1z^{-1} + a_2z^{-2})^{-1}$$

$$\text{poles } z_{p1,2} = \frac{-a_1 \pm \sqrt{a_1^2 - 4a_2}}{2}$$

for stability

$$(i) a_1^2 - 4a_2 \geq 0$$

$$\text{if } a_1 \geq 0, \quad \frac{-a_1 - \sqrt{a_1^2 - 4a_2}}{2} \geq -1$$

$$\Rightarrow \sqrt{a_1^2 - 4a_2} \leq 2 - a_1$$

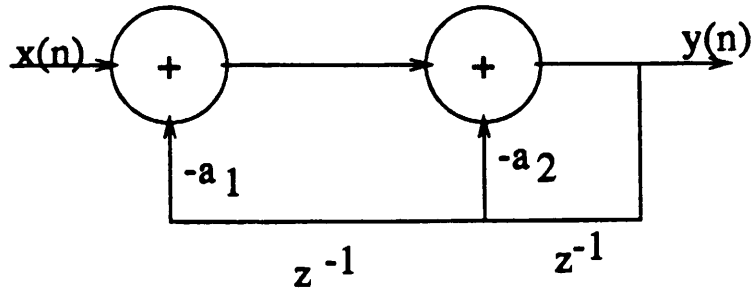

Figure 7.38:

$$\begin{aligned}
 &\Rightarrow a_1 \leq 2 \text{ and } a_1 - a_2 \leq 1 \\
 \text{if } a_1 < 0, & \quad \frac{-a_1 - \sqrt{a_1^2 - 4a_2}}{2} \leq 1 \\
 &\quad \Rightarrow \sqrt{a_1^2 - 4a_2} \leq 2 + a_1 \\
 &\Rightarrow a_1 \geq -2 \text{ and } a_1 + a_2 \geq -1 \\
 \text{(ii)} & \quad \left(-\frac{a_1}{2}\right)^2 + \left(\frac{\sqrt{4a_2 - a_1^2}}{2}\right) \leq 1 \\
 &\quad \quad \quad a_2 \leq 1
 \end{aligned}$$

Refer to fig 7.39. The region of stability in the $a_1 - a_2$ plane is shaded in the figure. There are nine integer pairs (a_1, a_2) which satisfy the stability conditions. These are (with corresponding system functions):

$$\begin{aligned}
 (0, -1) \quad H_{R_1}(z) &= (1 - z^{-2})^{-1} \\
 (0, 0) \quad H_{R_2}(z) &= 1 \\
 (0, 1) \quad H_{R_3}(z) &= (1 + z^{-2})^{-1} \\
 (1, 0) \quad H_{R_4}(z) &= (1 + z^{-1})^{-1} \\
 (1, 1) \quad H_{R_5}(z) &= (1 + z^{-1} + z^{-2})^{-1} \\
 (2, 1) \quad H_{R_6}(z) &= (1 + 2z^{-1} + z^{-2})^{-1} \\
 (-1, 0) \quad H_{R_7}(z) &= (1 - z^{-1})^{-1} \\
 (-1, 1) \quad H_{R_8}(z) &= (1 - z^{-1} + z^{-2})^{-1} \\
 (-2, 1) \quad H_{R_9}(z) &= (1 - 2z^{-1} + z^{-2})^{-1}
 \end{aligned}$$

(b)

$$\begin{aligned}
 H_{R_1}(z) &= H_{R_4}(z)H_{R_7}(z) \\
 H_{R_6}(z) &= H_{R_4}(z)H_{R_4}(z) \\
 H_{R_9}(z) &= H_{R_7}(z)H_{R_7}(z)
 \end{aligned}$$

The stable area of (q, a_2)

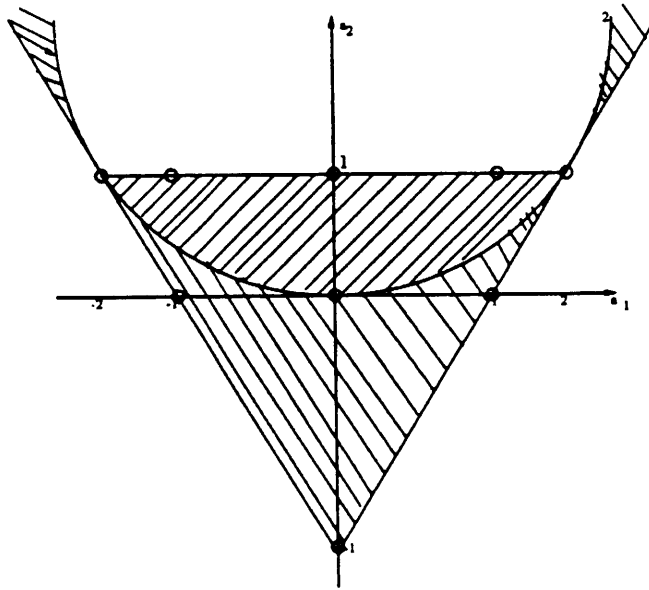

Figure 7.39:

(c) Only the following cases can make $h(n)$ FIR:

(i)

$$h_R(n) = \delta(n)$$

$$\text{Then } H(z) = \sum_{i=0}^N z^{-i}$$

$$y(n) = \sum_{i=0}^N x(n-i)$$

(ii)

$$h_R(n) * h_F(n) = \delta(n)$$

$$\text{Then } H(z) = 1$$

$$y(n) = x(n)$$

(d) see above.

7.43

Refer to fig 7.40

Note that 4 multiplications and 3 additions are required to implement $H_1(z)$. The advantage of Horner's method is in evaluating $H_1(z)$ for a specific z_0 . Thus, if

$$H_1(z) = b_0 + b_0 b_1 z^{-1} + b_0 b_1 b_2 z^{-2} + b_0 b_1 b_2 b_3 z^{-3}$$

$$= b_0 + z^{-1}(b_0 b_1 + z^{-1}(b_0 b_1 b_2 + z^{-1} b_0 b_1 b_2 b_3))$$

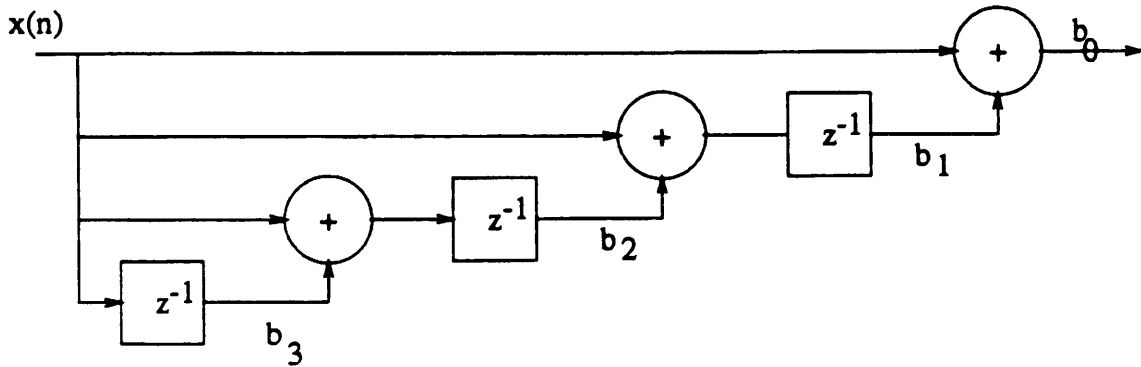

Figure 7.40: Structure of $H_1(z)$

the 3 multiplications and 3 additions are required for the evaluation of 7.1 in the field of z . If the various powers of z are prestored, then Horner's scheme has no advantage over the direct evaluation of 7.1. Refer to fig 7.41

This requires 4 multiplications and 3 additions. The linear-phase system is written as

$$H(z) = z^2 a_3 + z a_2 + a_1 + z^{-1} a_0 + z^{-2} a_1 + z^{-3} a_2 + z^{-4} a_3$$

By applying Horner's scheme, we can rewrite this as

$$H(z) = z^3 (a_3 + z^{-1} (a_2 + z^{-1} (a_1 + z^{-1} (a_0 + z^{-1} (a_1 + z^{-1} (a_2 + z^{-1} a_3))))))$$

Assuming that z^{-1} and z are given, a direct evaluation of $H(z)$ at $z = z_0$ requires 8 multiplications and 6 additions. Using Horner's scheme based on 7.43, requires the same number of operations as direct evaluation of $H(z)$. Hence, Horner's scheme does not offer any savings in computation.

7.44

(a) When x_1 and x_2 are positive, the result is obvious. If x_1 and x_2 are negative, let

$$\begin{aligned} x_1 &= -0 n_1 n_2 \dots n_b \\ &= -0 \bar{n}_1 \bar{n}_2 \dots \bar{n}_b + 000 \dots 01 \\ x_2 &= -0 m_1 m_2 \dots m_b \\ &= -1 \bar{m}_1 \bar{m}_2 \dots \bar{m}_b + 000 \dots 01 \\ x_3 &= x_1 + x_2 \\ &= -0 \bar{n}_1 0 \dots 0 + 0 \bar{m}_1 0 \dots 0 + c \\ \text{where } c &= 00 \bar{n}_2 \dots \bar{n}_b + 00 \bar{m}_2 \dots \bar{m}_b + 000 \dots 010 \end{aligned}$$

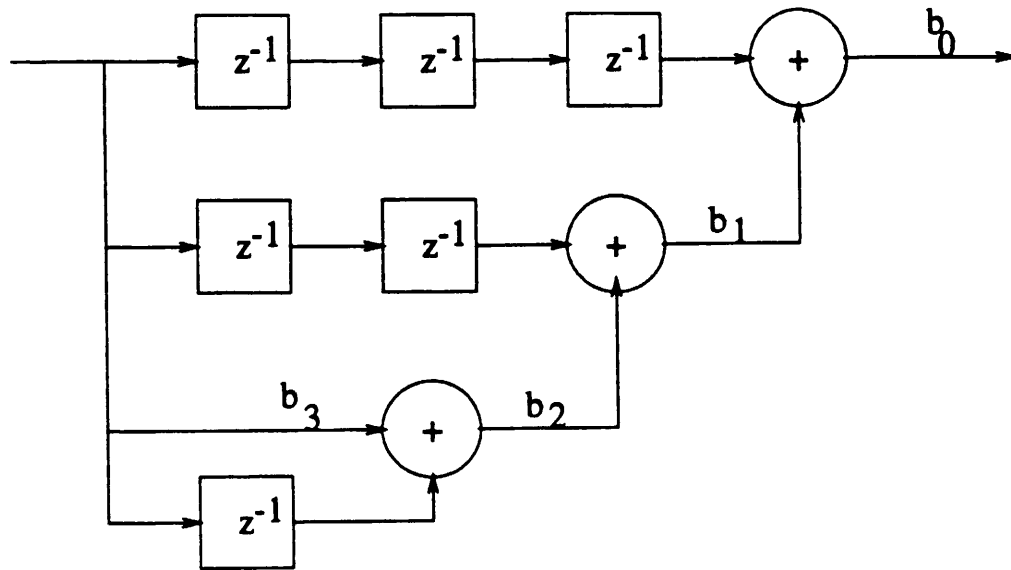

Figure 7.41: Structure of $H(z) = b_0 z^{-3} + b_0 b_1 z^{-2} + b_0 b_1 b_2 z^{-1} + b_0 b_1 b_2 b_3$

If the sign changes, there are two possibilities

$$\begin{aligned}
 (i) \quad & \bar{n}_1 = \bar{m}_1 = 0 \\
 & \Rightarrow n_1 = m_1 = 1 \\
 & \Rightarrow |x_1| > \frac{1}{2}, \quad |x_2| > \frac{1}{2} \\
 & \Rightarrow |x_3| > 1, \text{ overflow} \\
 (ii) (\bar{n}_1 = 1, \bar{m}_1 = 0, c = 0) \quad & \text{or} \quad (\bar{n}_1 = 0, \bar{m}_1 = 1, c = 0) \\
 \Rightarrow (|0 \bar{n}_1 0 \dots 0|_{10}) > \frac{1}{2} \quad & \text{or} \quad (|0 \bar{m}_1 0 \dots 0|_{10}) > \frac{1}{2} \\
 \text{and } |c_{10}| > \frac{1}{2} & \\
 \Rightarrow |x_3| > 1, \text{ overflow} &
 \end{aligned}$$

(b)

$$\begin{aligned}
 x_1 &= 0100 \\
 x_2 &= 0110 \\
 x_3 &= -0110 = 1010 \\
 x_1 + x_2 &= 1010, \text{ overflow} \\
 x_1 + x_2 + x_3 &= 0100, \text{ correct result}
 \end{aligned}$$

7.45

(a)

$$\begin{aligned}
 H(z) &= \frac{-a + z^{-1}}{1 - az^{-1}} \\
 |H(e^{j\omega})|^2 &= \left| \frac{-a + e^{-j\omega}}{1 - ae^{-j\omega}} \right|^2 \\
 &= \frac{(-a + \cos\omega)^2 + (-\sin\omega)^2}{(1 - a\cos\omega)^2 + (a\sin\omega)^2} \\
 &= \frac{a^2 - 2a\cos\omega + 1}{1 - 2a\cos\omega + a^2} = 1 \quad \forall \omega
 \end{aligned}$$

(b) Refer to fig 7.42

(c) If $|\hat{a}| = |-\hat{a}|$, where \hat{a} means the quantized value of a , then the filter remains all-pass.

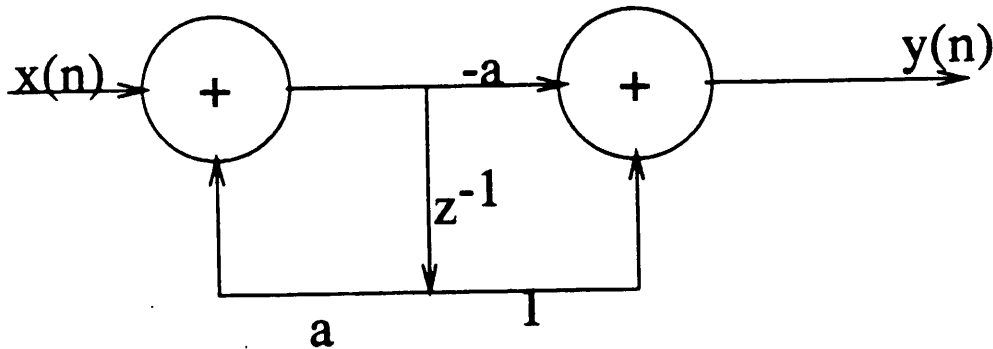

Figure 7.42:

(d) Refer to fig 7.43

(e) Yes, it is still all-pass.

7.46

(a) $y(n) = [2(\frac{1}{2})^n - (\frac{1}{4})^n] u(n)$

(b) Quantization table

$$x > 1 - \frac{1}{32} \quad \bar{x} = 1$$

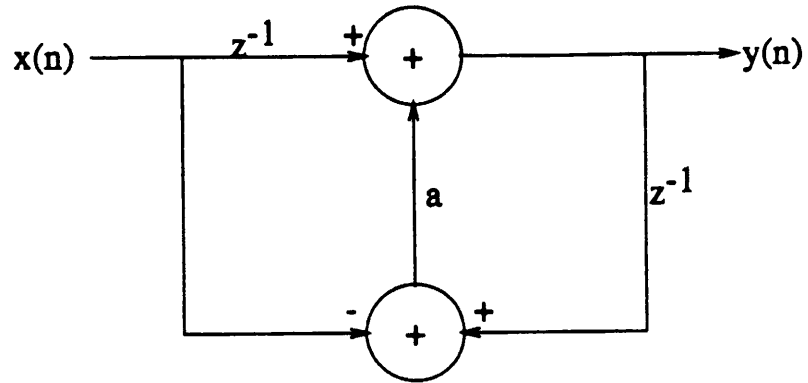

Figure 7.43:

$$\frac{31}{32} \geq z > \frac{29}{32} \quad \bar{x} = \frac{15}{16}$$

$$\frac{29}{32} \geq z > \frac{27}{32} \quad \bar{x} = \frac{14}{16}$$

$$\frac{1}{32} \geq z > \frac{1}{32} \quad \bar{x} = \frac{14}{16}$$

$$z < -1 + \frac{1}{32} \quad \bar{x} = -1$$

$$\text{Therefore } \bar{x}(n) = \left\{ 1, \frac{4}{16}, \frac{1}{16}, 0, \dots, 0 \right\}$$

$$\bar{y}(n) = \frac{8}{16} \bar{y}(n-1) + \bar{x}(n)$$

$$\bar{y}(n) = \left\{ 1, \frac{12}{16}, \frac{7}{16}, \frac{3}{16}, \frac{1}{16}, 0, 0, \dots \right\}$$

(c)

$$y(n) = \left\{ 1, \frac{3}{4}, \frac{7}{16}, \frac{15}{64}, \frac{31}{256}, \frac{63}{1024}, \dots \right\}$$

$$\bar{y}(n) = \left\{ 1, \frac{3}{4}, \frac{7}{16}, \frac{12}{64}, \frac{16}{256}, 0, 0, \dots \right\}$$

Errors occur when number becomes small.

7.47

$$y(n) = 0.999y(n-1) + e(n)$$

$e(n)$ is white noise, uniformly distributed in the interval $[-\frac{1}{2^8}, \frac{1}{2^8}]$

$$\begin{aligned} E\{y^2(n)\} &= 0.999^2 E\{y^2(n-1)\} + E\{e^2(n)\} \\ (1 - 0.999^2)E\{y^2(n)\} &= E\{e^2(n)\} \\ &= \int_{-\frac{\Delta}{2}}^{\frac{\Delta}{2}} \frac{1}{\Delta} e^2 de \\ &= \frac{\Delta^2}{12} \text{ where } \Delta = 2^{-8} \\ \text{Therefore, } E\{y^2(n)\} &= \frac{1}{12} \left(\frac{1}{2^8}\right)^2 \frac{1}{1 - 0.999^2} \\ &= 6.361 \times 10^{-4} \end{aligned}$$

7.48

- (a) poles $z_{p1} = 0.695$, $z_{p2} = 0.180$ Refer to fig 7.44
- (b) Truncation

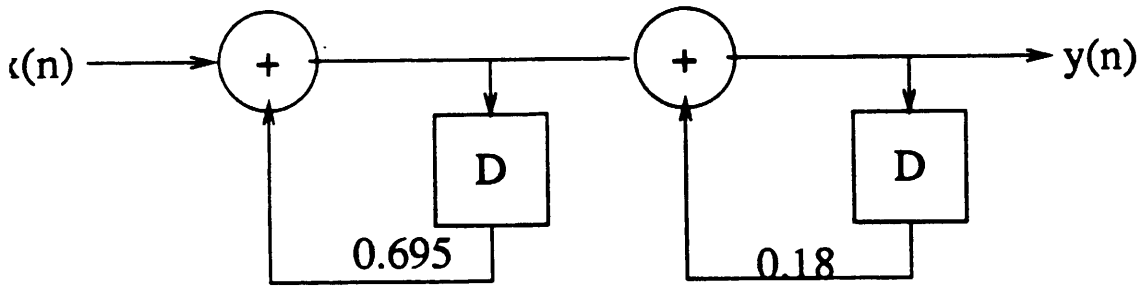

Figure 7.44:

$$0.695 - \frac{5}{8} = 0.625$$

$$\begin{aligned} & 0.180 \rightarrow \frac{1}{8} = 0.125 \\ \text{poles } \bar{z}_{p1} = 0.625, \quad \bar{z}_{p2} = 0.125 \end{aligned}$$

(c) Rounding

$$\begin{aligned} & 0.695 \rightarrow \frac{6}{8} = 0.75 \\ & 0.180 \rightarrow \frac{1}{8} = 0.125 \\ \text{poles } \bar{z}_{p1} = 0.75, \quad \bar{z}_{p2} = 0.125 \end{aligned}$$

(d)

$$|0.75 - 0.695| < |0.695 - 0.625|$$

Rounding is better

$$|H_a(w)| = [(1.483 + 1.39\cos w)(1.0324 + 0.36\cos w)]^{-\frac{1}{2}}$$

$$|H_b(w)| = [(1.391 + 1.25\cos w)(1.0156 + 0.25\cos w)]^{-\frac{1}{2}}$$

$$|H_c(w)| = [(1.563 + 1.5\cos w)(1.0156 + 0.25\cos w)]^{-\frac{1}{2}}$$

7.49

(a)

$$H_1(z) = 1 - \frac{1}{2}z^{-1}$$

$$h_1(n) = \left\{ 1, -\frac{1}{2} \right\}$$

$$H_2(z) = \left(1 - \frac{1}{4}z^{-1}\right)^{-1}$$

$$h_2(n) = \left(\frac{1}{4}\right)^n u(n)$$

$$H_3(z) = \left(1 + \frac{1}{4}z^{-1}\right)^{-1}$$

$$h_3(n) = \left(-\frac{1}{4}\right)^n u(n)$$

Refer to fig 7.45 Cascade the three systems in six possible permutations to obtain six realizations.

(b) Error sequence $e_i(n)$ is uniformly distributed over interval $(\frac{1}{2}2^{-b}, \frac{1}{2}2^{-b})$. So $\sigma_e^2 = \frac{2^{-2b}}{12}$ for any i (call it σ_e^2)

(c) consider cascade $H_1 - H_2 - H_3$ Refer to fig 7.46

$$h_4(n) = h_2(n) * h_3(n)$$

$$= \left\{ 1, 0, \frac{1}{16}, 0, \left(\frac{1}{16}\right)^2, 0, \dots \right\}$$

$$\sigma_4^2 = \sigma_e^2 \left[2 \sum_{n=0}^{\infty} h_4^2(n) + \sum_{n=0}^{\infty} h_3^2(n) \right]$$

$$= \sigma_e^2 \left[\frac{2}{1 - \left(\frac{1}{16}\right)^2} + \frac{1}{1 - \left(\frac{1}{4}\right)^2} \right]$$

$$= 3.0745\sigma_e^2$$

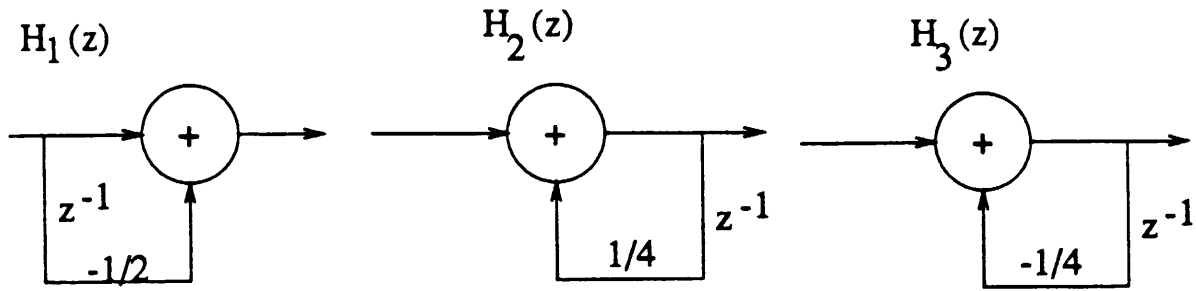

Figure 7.45:

using similar methods:

$$H_1 - H_2 - H_3 \quad \sigma_q^2 = 3.0745\sigma_e^2$$

$$H_2 - H_1 - H_3 \quad \sigma_q^2 = 3.3882\sigma_e^2$$

$$H_2 - H_3 - H_1 \quad \sigma_q^2 = 3.2588\sigma_e^2$$

$$H_3 - H_1 - H_2 \quad \sigma_q^2 = 3.2627\sigma_e^2$$

$$H_3 - H_2 - H_1 \quad \sigma_q^2 = 3.3216\sigma_e^2$$

7.50

$$y(n) = Q[0.1\delta(n)] + Q[\alpha y(n-1)]$$

(a)

$$y(n) = Q[0.1\delta(n)] + Q[0.5y(n-1)]$$

$$y(0) = Q[0.1] = \frac{1}{8}$$

$$y(1) = Q\left[\frac{1}{16}\right] = 0$$

$$y(2) = y(3) = y(4) = 0$$

no limit cycle

(b)

$$y(n) = Q[0.1\delta(n)] + Q[0.75y(n-1)]$$

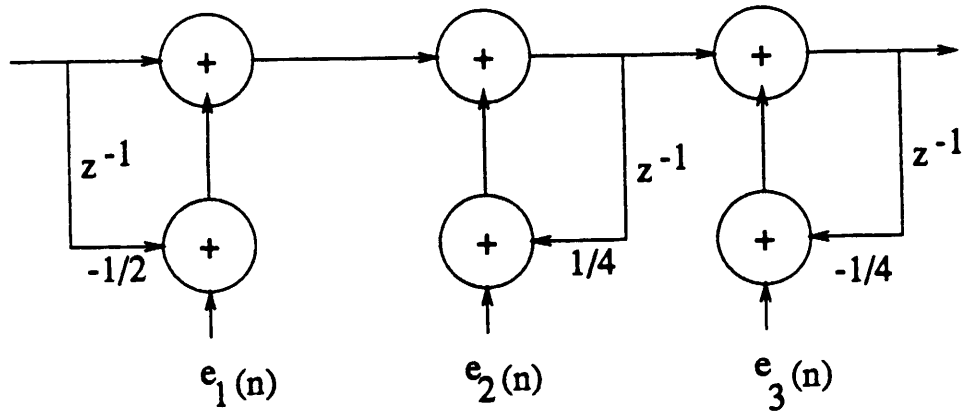

Figure 7.46:

$$y(0) = Q[0.1] = \frac{1}{8}$$

$$y(1) = Q\left[\frac{3}{32}\right] = \frac{1}{8}$$

$$y(2) = Q\left[\frac{3}{32}\right] = \frac{1}{8}$$

$$y(3) = y(4) = \frac{1}{8}$$

limit cycle occurs

7.51

(a) $\sigma_x^2 = r_{xx}(0) = 3 \Rightarrow A_x = \frac{1}{\sqrt{3}}$

(b)

$$\Delta = 2^{-6}$$

$$\sigma_e^2 = \frac{\Delta^2}{12}$$

$$= \frac{1}{12 \times 2^{12}}$$

so SNR = $10 \log_{10} \frac{1}{\sigma_e^2}$

$$= 10 \log_{10}(12 \times 2^{12})$$

$$= 46.91 \text{ dB}$$

(c) left-justified.

(d)

$$\begin{aligned}\sigma_q^2 &= \sigma_c^2 \sum_{n=0}^{\infty} h^2(n) + \sigma_{e1}^2 \sum_{n=0}^{\infty} h^2(n) \\ \text{Now } \sigma_{e1}^2 &= \frac{1}{12} \left(\frac{1}{2^8}\right)^2 \\ \text{and } \sum_n h^2(n) &= \frac{1}{1 - 0.75^2} = \frac{16}{7}, \\ \text{so } \sigma_q^2 &= \frac{16}{7} \left(\frac{1}{12} \left(\frac{1}{2^8}\right)^2 + \frac{1}{12} \left(\frac{1}{2^6}\right)^2 \right) \\ &= \frac{17}{344,064} \\ \text{and SNR} &= 10 \log_{10} \frac{1}{\sigma_q^2} \\ &= 43.06 \text{ dB}\end{aligned}$$

7.52

Define $\rho_c \triangleq r \cos \theta$, $\rho_s \triangleq r \sin \theta$ for convenience, (a)

$$\begin{aligned}-\rho_s y(n-1) + e_1(n) + x(n) + \rho_c v(n-1) + e_2(n) &= v(n) \\ \rho_s v(n-1) + e_3(n) + \rho_c y(n-1) + e_4(n) &= y(n)\end{aligned}$$

(b)

$$\begin{aligned}-\rho_s z^{-1} Y(z) + E_1(z) + X(z) + \rho_c z^{-1} V(z) + E_2(z) &= V(z) \\ \rho_s z^{-1} V(z) + E_3(z) + \rho_c z^{-1} Y(z) + E_4(z) &= Y(z) \\ Y(z) &= \frac{\rho_s z^{-1}}{1 - 2\rho_c z^{-1} + r^2 z^{-2}} [X(z) + E_1(z) + E_2(z)] \\ &\quad + \frac{1 - \rho_c z^{-1}}{1 - 2\rho_c z^{-1} + r^2 z^{-2}} [E_3(z) + E_4(z)] \\ &= H_1(z) X(z) + H_1(z) [E_1(z) + E_2(z)] \\ &\quad + H_2(z) [E_3(z) + E_4(z)]\end{aligned}$$

when $H_1(z)$ and $H_2(z)$ are as defined in the problem statement

$$\begin{aligned}h_1(n) &= \rho_s \frac{1}{\sin \theta} r^{n-1} \sin n \theta u(n-1) \\ &= r^n \sin n \theta u(n-1) \\ &= r^n \sin n \theta u(n) \\ h_2(n) &= \frac{1}{\sin \theta} r^n \sin(n+1) \theta u(n) + \rho_c \frac{1}{\sin \theta} r^{n-1} \sin \theta n u(n-1) \\ &= \delta(n) + \frac{r^n}{\sin \theta} [\sin(n+1) \theta - \cos \theta \sin n \theta] u(n-1) \\ &= \delta(n) + r^n \cos n \theta u(n-1) \\ &= r^n \cos n \theta u(n)\end{aligned}$$

(c)

$$\sigma_c^2 = \sigma_{e1}^2 = \sigma_{e2}^2 = \sigma_{e3}^2 = \sigma_{e4}^2 = \frac{\Delta^2}{12}$$

$$\begin{aligned}
&= \frac{1}{12}(2^{-b})^2 \\
&= \frac{2^{-2b}}{12} \\
\sigma_q^2 &= 2\sigma_e^2 \sum_{n=0}^{\infty} h_1^2(n) + 2\sigma_e^2 \sum_{n=0}^{\infty} h_2^2(n) \\
&= 2\sigma_e^2 \sum_{n=0}^{\infty} [r^{2n} \sin^2 n\theta + r^{2n} \cos^2 n\theta] \\
&= 2\sigma_e^2 \frac{1}{1-r^{2n}} \\
&= \frac{2^{-2b}}{6} \frac{1}{1-r^{2n}}
\end{aligned}$$

7.53

(a)

$$\begin{aligned}
h_1(n) &= \left(\frac{1}{2}\right)^n u(n) \\
h_2(n) &= \left(\frac{1}{4}\right)^n u(n) \\
h(n) &= \left[2\left(\frac{1}{2}\right)^n - \left(\frac{1}{4}\right)^n\right] u(n) \\
\sigma_q^2 &= 2\sigma_{e1}^2 \sum_{n=0}^{\infty} h_1^2(n) + 2\sigma_{e2}^2 \sum_{n=0}^{\infty} h_2^2(n) \\
&= \frac{64}{35}\sigma_{e1}^2 + \frac{16}{15}\sigma_{e2}^2
\end{aligned}$$

(b)

$$\begin{aligned}
\sigma_q^2 &= \sigma_{e1}^2 \sum_n h^2(n) + \sigma_{e2}^2 \sum_n h_1^2(n) \\
&= \frac{64}{35}\sigma_{e1}^2 + \frac{4}{3}\sigma_{e2}^2
\end{aligned}$$

7.54

Refer to fig 7.47

$$\begin{aligned}
\sigma_{e_i}^2 &= \frac{1}{12}2^{-2b} \forall i \\
\sigma_q^2 &= (M-1)\sigma_{e_i}^2 \\
&= \frac{(M-1)}{12}2^{-2b}
\end{aligned}$$

7.55

$$H(z) = \frac{B(z)}{A(z)}$$

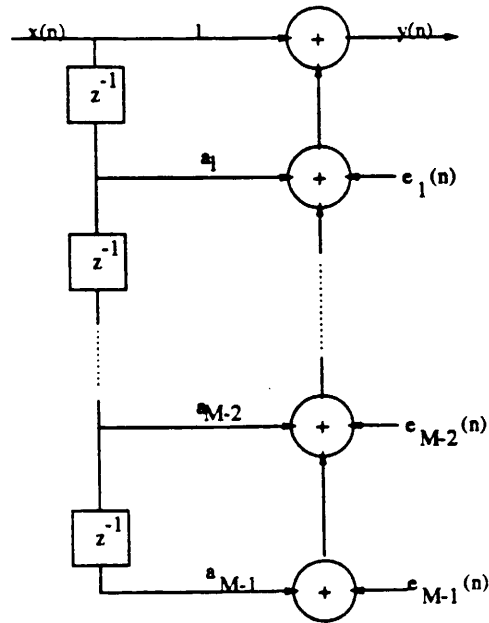

Figure 7.47:

$$\begin{aligned}
 &= \left[G_1 \frac{(1 - 0.8e^{j\frac{\pi}{4}})(1 - 0.8e^{-j\frac{\pi}{4}})}{(1 - 0.5z^{-1})(1 + \frac{1}{3}z^{-1})} \right. \\
 &\quad \left. G_2 \frac{(1 + 0.25z^{-1})(1 - \frac{5}{8}z^{-1})}{(1 - 0.8e^{j\frac{\pi}{3}})(1 - 0.8e^{-j\frac{\pi}{3}})} \right] \\
 &= H_1(z)H_2(z)
 \end{aligned}$$

(a)

$$\begin{aligned}
 z^{-1} &= e^{-j\omega} \\
 \text{At } \omega = 0, z^{-1} &= 1 \\
 H_1(\omega)|_{\omega=0} &= 1 \\
 G_1 \frac{(1 - 0.8e^{j\frac{\pi}{4}})(1 - 0.8e^{-j\frac{\pi}{4}})}{(1 - 0.5)(1 + \frac{1}{3})} &= 1 \\
 G_1 &= 1.1381 \\
 G_2 \frac{(1 + 0.25)(1 - \frac{5}{8})}{(1 - 0.8e^{j\frac{\pi}{3}})(1 - 0.8e^{-j\frac{\pi}{3}})} &= 1 \\
 G_2 &= 1.7920
 \end{aligned}$$

(b) Refer to fig 7.48.

(c) Refer to fig 7.49.

Refer to fig 7.50.

Refer to fig 7.51.

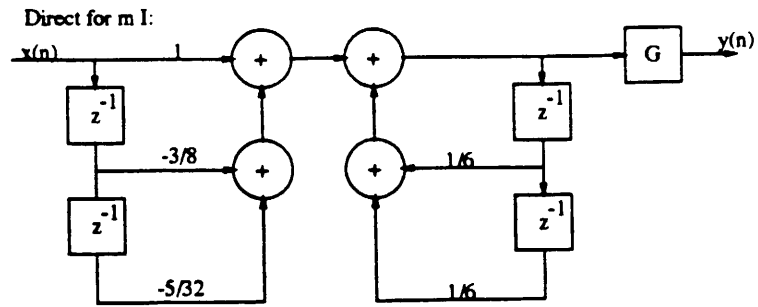

Direct form II and cascade structure:

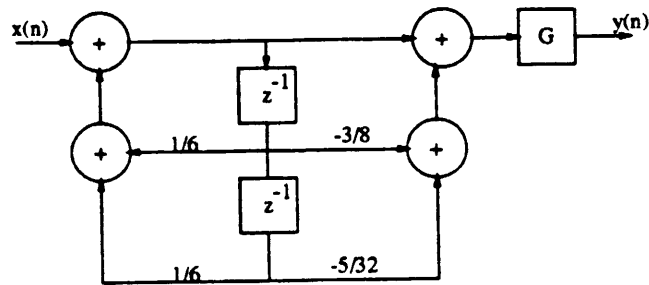

Figure 7.48:

7.56

(a)

$$\begin{aligned}
 k_1 &= \frac{-\frac{3}{8}}{\frac{27}{32}} \\
 &= -\frac{4}{9} \\
 k_2 &= -\frac{5}{32}
 \end{aligned}$$

Refer to fig 7.52a.

(b)

$$\begin{aligned}
 A(z) &= \frac{1}{(1 - 0.5z^{-1})(1 + \frac{1}{3}z^{-1})} \\
 &= \frac{1}{1 - \frac{1}{6}z^{-1} - \frac{1}{6}z^{-2}} \\
 k_2 &= -\frac{1}{6} \\
 k_1(1 + k_2) &= -\frac{1}{6} \\
 k_1 &= -\frac{1}{5}
 \end{aligned}$$

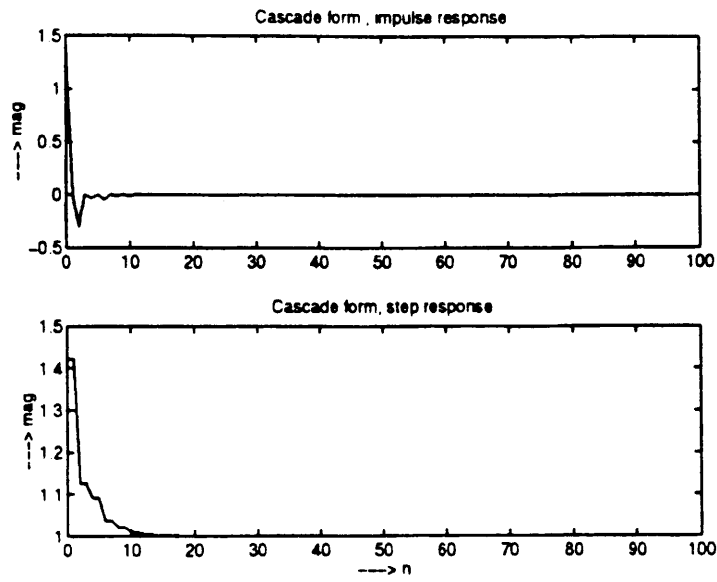

Figure 7.51:

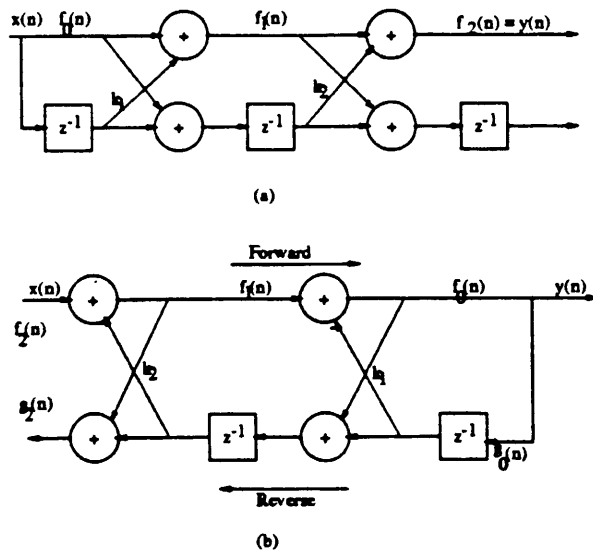

Figure 7.52:

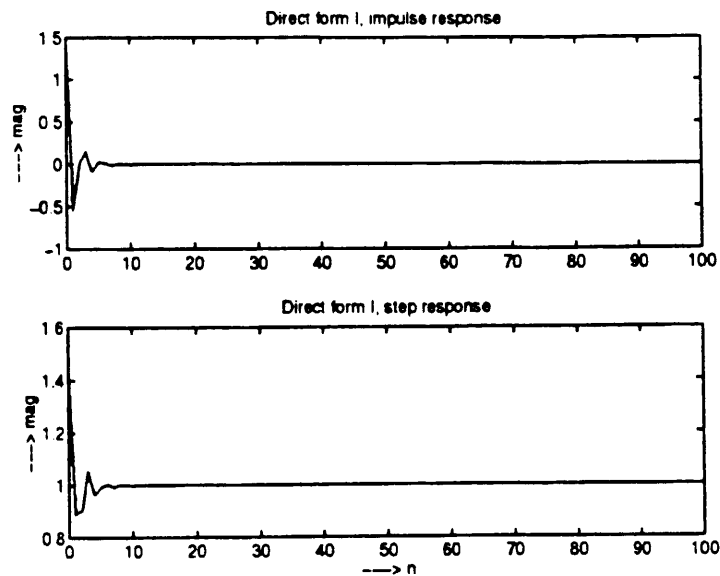

Figure 7.49:

- Refer to fig 7.52b.
 (c) Refer to fig 7.53.
 (e) Refer to fig 7.54.
 (f) Finite word length effects are visible in $h(n)$ for part f.

7.57

- (a) Refer to fig 7.55.

$$c = \frac{15}{16}$$

$$H_1(z) = \frac{\frac{9}{10}}{1 - \frac{1}{2}z^{-1}}$$

$$H_2(z) = \frac{\frac{83}{80}}{1 + \frac{1}{3}z^{-1}}$$

- (b) Refer to fig 7.55.
 (c) $N = 100$;
 $x = [1 \text{ zeros}(1, N-1)]$;
 $c = 15/16$;
 $a1 = 9/10$;
 $a2 = 83/80$;
 $p1 = 0.5$;
 $p2 = -1/3$;
 $y1(1) = a1*x(1)$;
 $y2(1) = a2*x(1)$;
 $y(1) = c*x(1) + y1(1) + y2(1)$;
 for $i=2:N$,
 $y1(i) = a1*x(i) + p1*y1(i-1)$;
 $y2(i) = a2*x(i) + p2*y2(i-1)$;

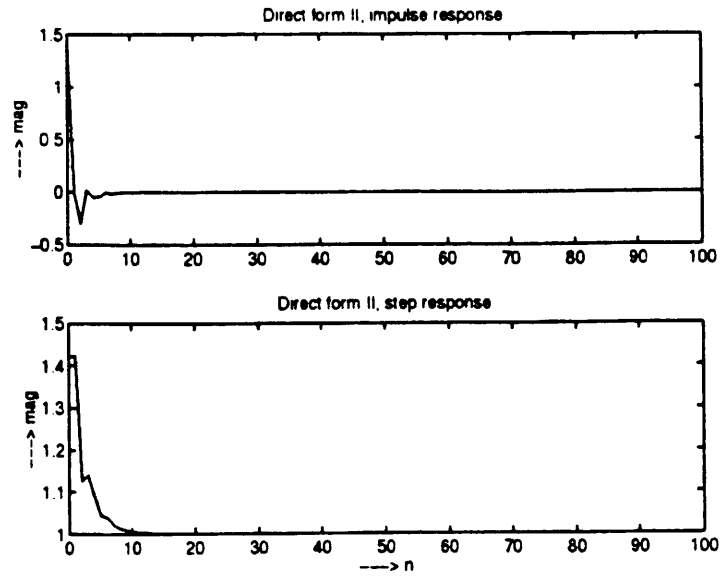

Figure 7.50:

```

    y(i) = c*x(i) + y1(i) + y2(i);
end
(d) Refer to fig 7.56.

```

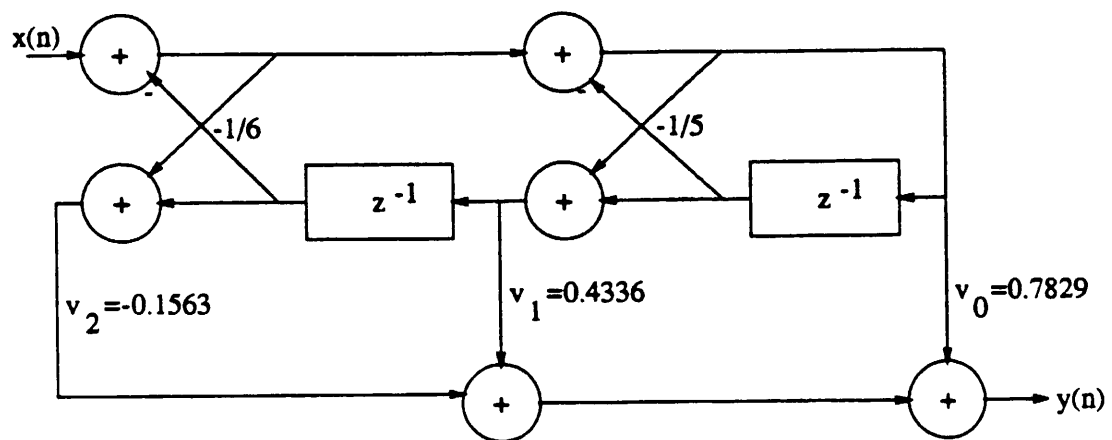

Figure 7.53:

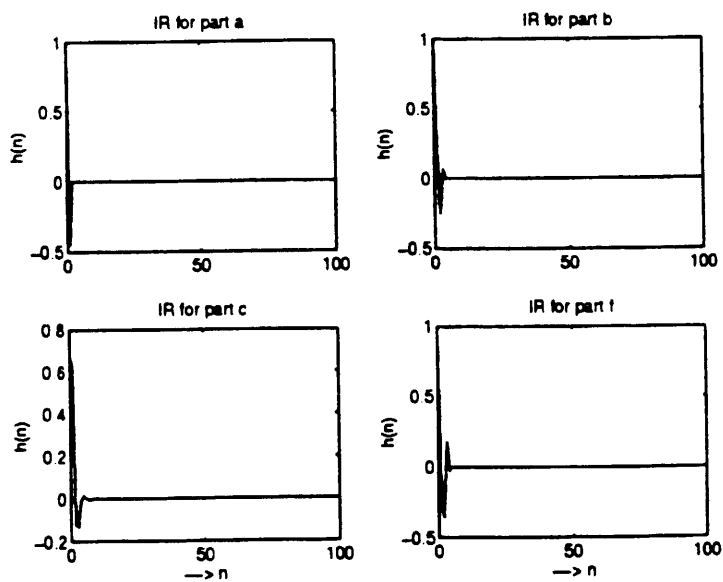

Figure 7.54:

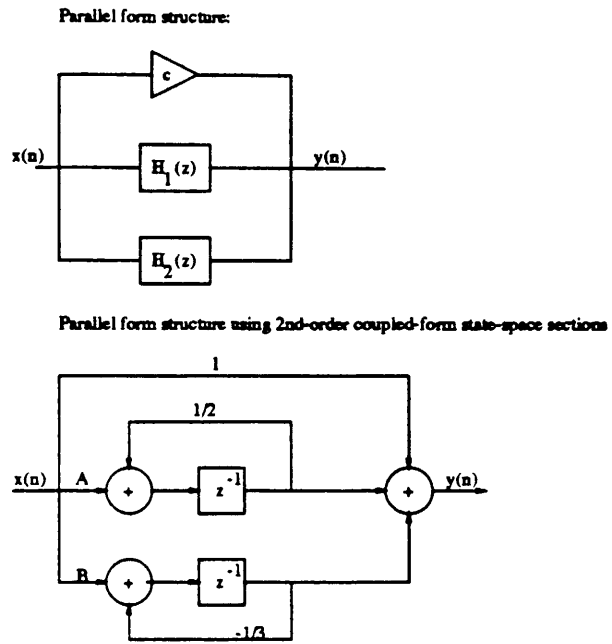

Figure 7.55:

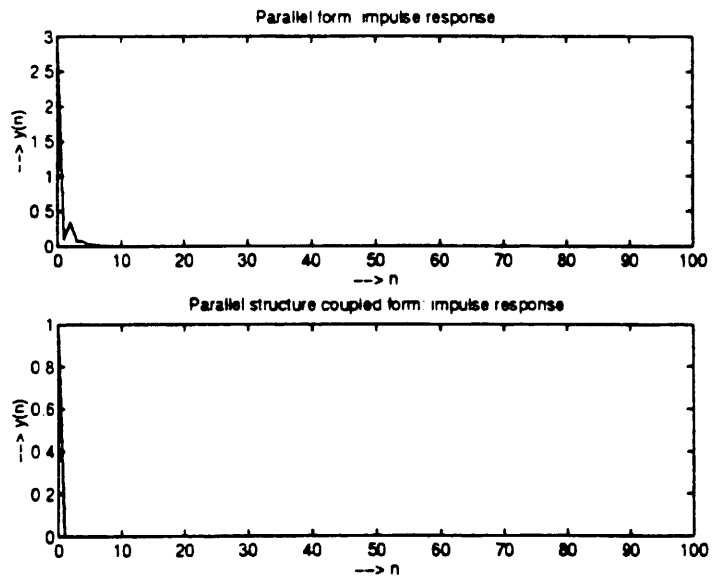

Figure 7.56:

Chapter 8

8.1

(a) To obtain the desired length of 25, a delay of $\frac{25-1}{2} = 12$ is incorporated into $H_d(w)$. Hence,

$$\begin{aligned}
 H_d(w) &= 1e^{-j12w}, \quad 0 \leq |w| \leq \frac{\pi}{6} \\
 &= 0, \quad \text{otherwise} \\
 h_d(n) &= \frac{1}{2\pi} \int_{-\frac{\pi}{6}}^{\frac{\pi}{6}} H_d(w)e^{-jwn} dw \\
 &= \frac{\sin \frac{\pi}{6}(n-12)}{\pi(n-12)}
 \end{aligned}$$

Then, $h(n) = h_d(n)w(n)$

where $w(n)$ is a rectangular window of length $N = 25$.

(b) $H(w) = \sum_{n=0}^{24} h(n)e^{-jwn} \Rightarrow$ plot $|H(w)|$ and $\angle H(w)$. Refer to fig 8.1.

(c) Hamming window:

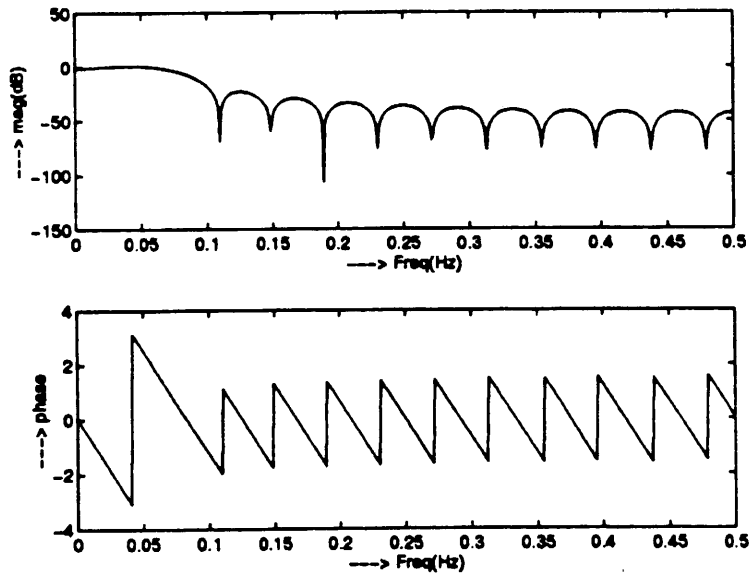

Figure 8.1:

$$w(n) = (0.54 - 0.46 \cos \frac{n\pi}{12})$$

$$h(n) = h_d(n)w(n) \quad \text{for } 0 \leq n \leq 24$$

Refer to fig 8.2.
 (d) Bartlett window:

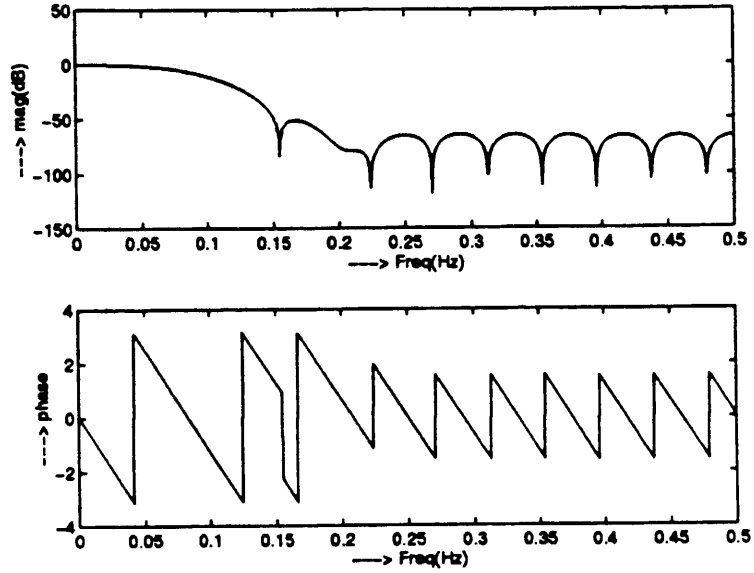

Figure 8.2:

$$w(n) = 1 - \frac{2(n-12)}{24} \quad 0 \leq n \leq 24$$

Refer to fig 8.3.

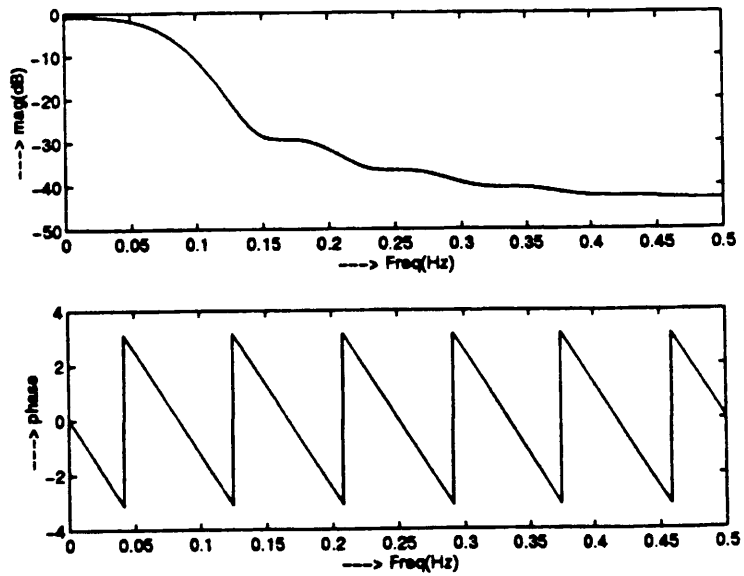

Figure 8.3:

8.2

(a)

$$\begin{aligned}
 H_d(w) &= 1e^{-j12w}, \quad |w| \leq \frac{\pi}{6}, \quad \frac{\pi}{3} \leq |w| \leq \pi \\
 &= 0, \quad \frac{\pi}{6} \leq |w| \leq \frac{\pi}{3} \\
 h_d(n) &= \frac{1}{2\pi} \int_{-\pi}^{\pi} H_d(w)e^{-jwn} dw \\
 &= \delta(n) - \frac{\sin \frac{\pi}{3}(n-12)}{\pi(n-12)} + \frac{\sin \frac{\pi}{6}(n-12)}{\pi(n-12)}
 \end{aligned}$$

(b) Rectangular window:

$$\begin{aligned}
 w(n) &= 1, \quad 0 \leq n \leq 24 \\
 &= 0, \quad \text{otherwise}
 \end{aligned}$$

Refer to fig 8.4.

(c) Hamming window:

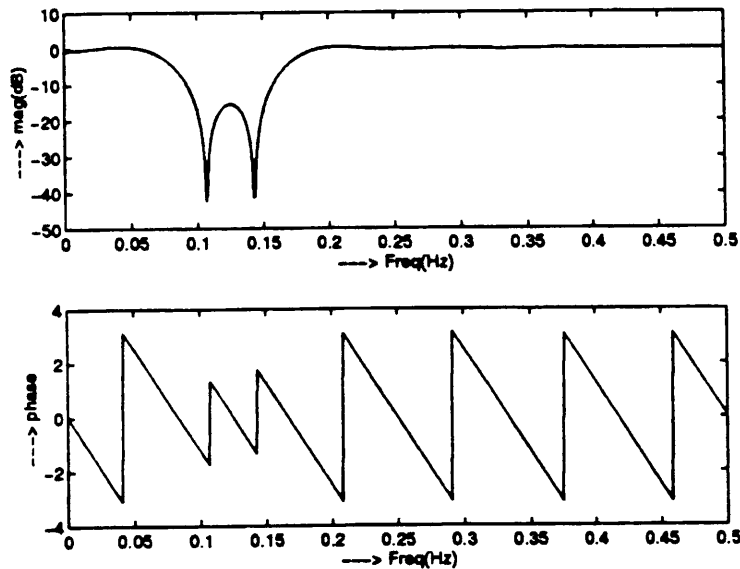

Figure 8.4:

$$\begin{aligned}
 w(n) &= (0.54 - 0.46 \cos \frac{n\pi}{12}) \\
 h(n) &= h_d(n)w(n) \\
 H(w) &= \sum_{n=0}^{24} h(n)e^{-jwn}
 \end{aligned}$$

Refer to fig 8.5.

(d) Bartlett window:

$$w(n) = 1 - \frac{(n-12)}{12}, \quad 0 \leq n \leq 24$$

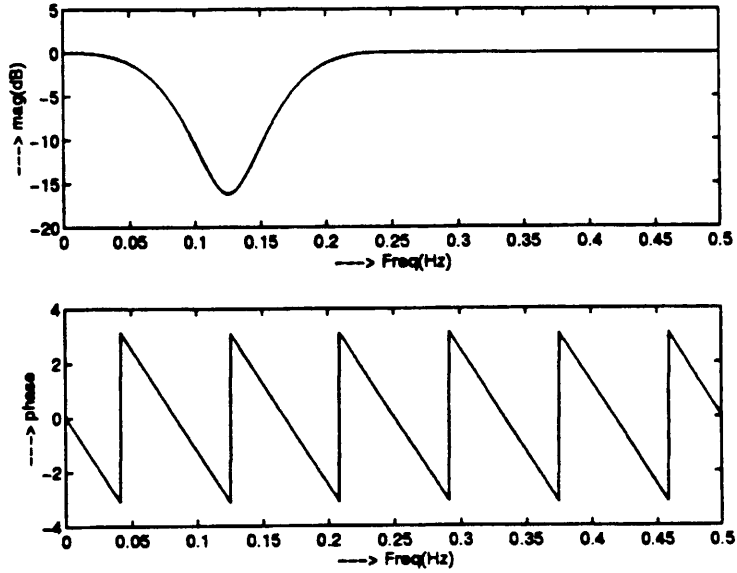

Figure 8.5:

Refer to fig 8.6.

Note that the magnitude responses in (c) and (d) are poor because the transition region is wide. To obtain sharper cut-off, we must increase the length N of the filter.

8.3

- (a) Hanning window: $w(n) = \frac{1}{2}(1 - \cos \frac{\pi n}{12})$, $0 \leq n \leq 24$. Refer to fig 8.7.
 (b) Blackman window: $w(n) = 0.42 - 0.5 \cos \frac{\pi n}{12} + 0.08 \cos \frac{\pi n}{6}$. Refer to fig 8.8.

8.4

- (a) Hanning window: Refer to fig 8.9.
 (b) Blackman window: Refer to fig 8.10.

The results are still relatively poor for these window functions.

8.5

$$M = 4, \quad H_r(0) = 1, \quad H_r\left(\frac{\pi}{2}\right) = \frac{1}{2}$$

$$\begin{aligned} H_r(\omega) &= 2 \sum_{n=0}^{\frac{M}{2}-1} h(n) \cos\left[\omega\left(\frac{M-1}{2} - n\right)\right] \\ &= 2 \sum_{n=0}^1 h(n) \cos\left[\omega\left(\frac{3}{2} - n\right)\right] \end{aligned}$$

$$\text{At } \omega = 0, H_r(0) = 1 = 2 \sum_{n=0}^1 h(n) \cos[0]$$

$$2[h(0) + h(1)] = 1 \quad (1)$$

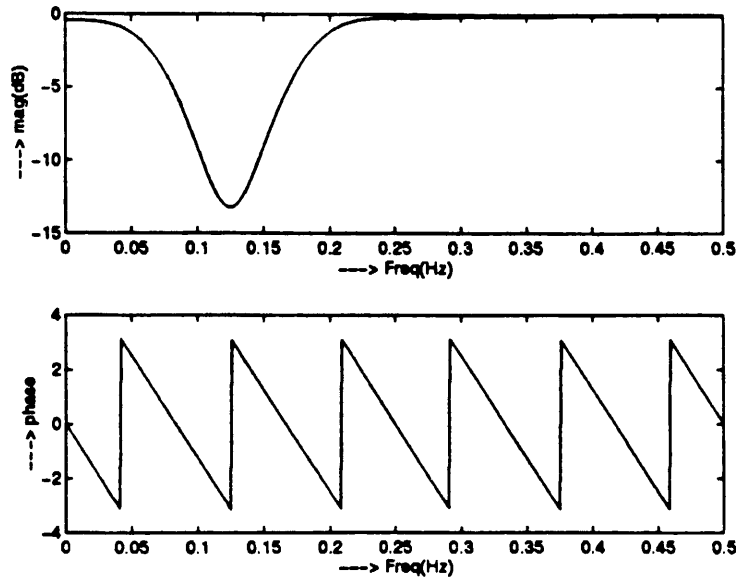

Figure 8.6:

$$\text{At } \omega = \frac{\pi}{2}, H_r\left(\frac{\pi}{2}\right) = \frac{1}{2} = 2 \sum_{n=0}^1 h(n) \cos\left[\frac{\pi}{2}\left(\frac{3}{2} - n\right)\right]$$

$$-h(0) + h(1) = 0.354 \quad (2)$$

Solving (1) and (2), we get

$$h(0) = 0.073 \text{ and}$$

$$h(1) = 0.427$$

$$h(2) = h(1)$$

$$h(3) = h(0)$$

$$\text{Hence, } h(n) = \{0.073, 0.427, 0.427, 0.073\}$$

8.6

$$M = 15. H_r\left(\frac{2\pi k}{15}\right) = \begin{cases} 1, & k = 0, 1, 2, 3 \\ 0, & k = 4, 5, 6, 7 \end{cases}$$

$$H_r(\omega) = h\left(\frac{M-1}{2}\right) + 2 \sum_{n=0}^{\frac{M-3}{2}} h(n) \cos\omega\left(\frac{M-1}{2} - n\right)$$

$$h(n) = h(M-1-n)$$

$$h(n) = h(14-n)$$

$$H_r(\omega) = h(7) + 2 \sum_{n=0}^6 h(n) \cos\omega(7-n) \quad \omega = \frac{2\pi k}{15}$$

Solving the above eqn yields,

$$h(n) = \{0.3189, 0.0341, -0.1079, -0.0365, 0.0667, 0.0412, -0.0498, 0.4667, 0.4667, -0.0498, 0.0412, 0.0667, -0.0365, -0.1079, 0.0341, 0.3189\}$$

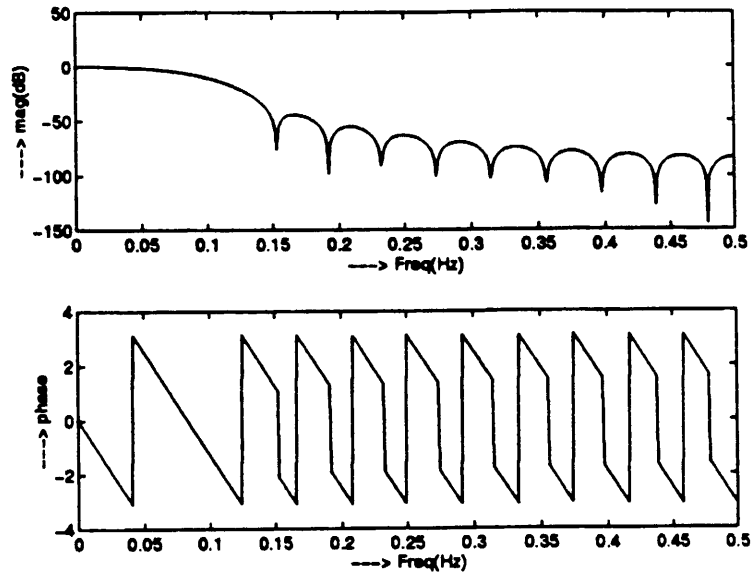

Figure 8.7:

8.7

$$M = 15. H_r\left(\frac{2\pi k}{15}\right) = \begin{cases} 1, & k = 0, 1, 2, 3 \\ 0.4, & k = 4 \\ 0, & k = 5, 6, 7 \end{cases}$$

$$H_r(\omega) = h\left(\frac{M-1}{2}\right) + 2 \sum_{n=0}^{\frac{M-3}{2}} h(n) \cos\omega\left(\frac{M-1}{2} - n\right)$$

$$h(n) = h(M-1-n)$$

$$h(n) = h(14-n)$$

$$H_r(\omega) = h(7) + 2 \sum_{n=0}^6 h(n) \cos\omega(7-n)$$

Solving the above eqn yields,

$$h(n) = \{0.3133, -0.0181, -0.0914, 0.0122, 0.0400, -0.0019, -0.0141, 0.52, 0.52, -0.0141, -0.0019, 0.0400, 0.0122, -0.0914, -0.0181, 0.3133\}$$

8.8

(a)

$$\begin{aligned} y_a(t) &= \frac{dx_a(t)}{dt} \\ &= \frac{d}{dt}[e^{j2\pi Ft}] \\ &= j2\pi F e^{j2\pi Ft} \end{aligned}$$

$$\text{Hence, } H(F) = j2\pi F$$

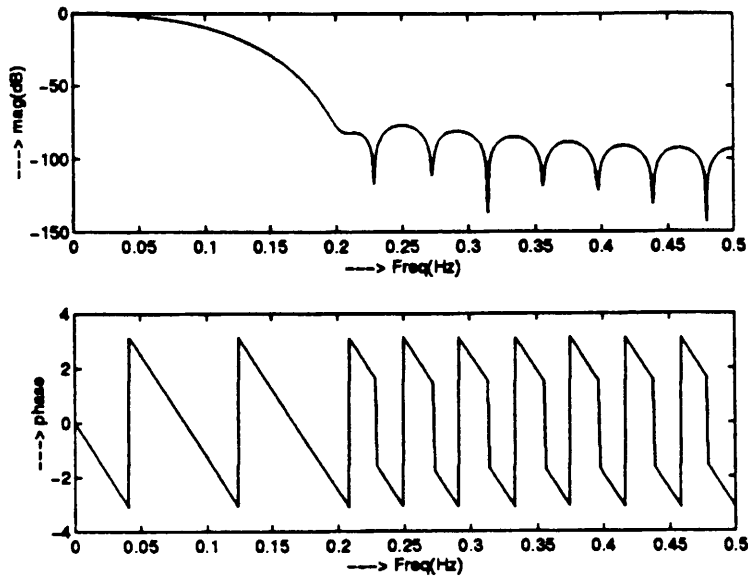

Figure 8.8:

(b)

$$\begin{aligned}
 |H(F)| &= 2\pi F \\
 \angle H(F) &= \frac{\pi}{2}, \quad F > 0 \\
 &= -\frac{\pi}{2}, \quad F < 0
 \end{aligned}$$

Refer to fig 8.11.

(c)

$$\begin{aligned}
 H(\omega) &= j\omega, \quad |\omega| \leq \pi \\
 |H(\omega)| &= |\omega| \\
 \angle H(\omega) &= \frac{\pi}{2}, \quad \omega > 0 \\
 &= -\frac{\pi}{2}, \quad \omega < 0
 \end{aligned}$$

Refer to fig 8.12.

we note that the digital differentiator has a frequency response that resembles the response of the analog differentiator.

(d)

$$\begin{aligned}
 y(n) &= x(n) - x(n-1) \\
 H(z) &= 1 - z^{-1} \\
 H(\omega) &= 1 - e^{-j\omega} \\
 &= e^{-j\frac{\omega}{2}} (2j \sin \frac{\omega}{2}) \\
 |H(\omega)| &= 2|\sin \frac{\omega}{2}| \\
 \angle H(\omega) &= \frac{\pi}{2} - \frac{\omega}{2}
 \end{aligned}$$

Refer to fig 8.13.

Note that for small ω , $\sin \frac{\omega}{2} \approx \frac{\omega}{2}$ and $H(\omega) \approx j\omega e^{-j\frac{\omega}{2}}$, which is a suitable approximation

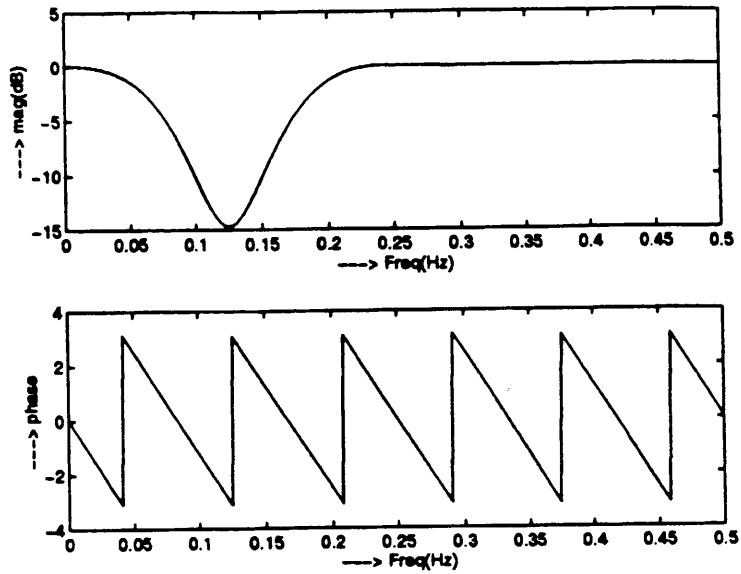

Figure 8.9:

to the differentiator in (c).

(e) The value $H(\omega_0)$ is obtained from (d) above. Then $y(n) = A|H(\omega_0)|\cos(\omega_0 n + \theta + \frac{\pi}{2} - \frac{\omega_0}{2})$

8.9

$$\begin{aligned}
 H_d(\omega) &= \omega e^{-j10\omega}, & 0 \leq \omega \leq \pi \\
 &= -\omega e^{-j10\omega}, & -\pi \leq \omega \leq 0 \\
 h_d(n) &= \frac{1}{2\pi} \int_{-\pi}^{\pi} H_d(\omega) e^{-j\omega n} d\omega \\
 &= \frac{\cos\pi(n-10)}{(n-10)}, & n \neq 10 \\
 &= 0, & n = 10 \\
 h_d(n) &= \frac{\cos\pi(n-10)}{(n-10)}, & 0 \leq n \leq 20, n \neq 10 \\
 &= 0, & n = 10
 \end{aligned}$$

With a Hamming window, we obtain the following frequency response: Refer to fig 8.14.

8.10

$H(s)$ has two zeros at $z_1 = -0.1$ and $z_2 = \infty$ and two poles $p_{1,2} = -0.1 \pm j3$. The matched z-transform maps these into:

$$\begin{aligned}
 \tilde{z}_1 &= e^{-0.1T} = e^{-0.01} = 0.99 \\
 \tilde{z}_2 &= e^{-\infty T} = 0 \\
 \tilde{p}_1 &= e^{(-0.1+j3)T} = 0.99e^{j0.3} \\
 \tilde{p}_2 &= 0.99e^{-j0.3}
 \end{aligned}$$

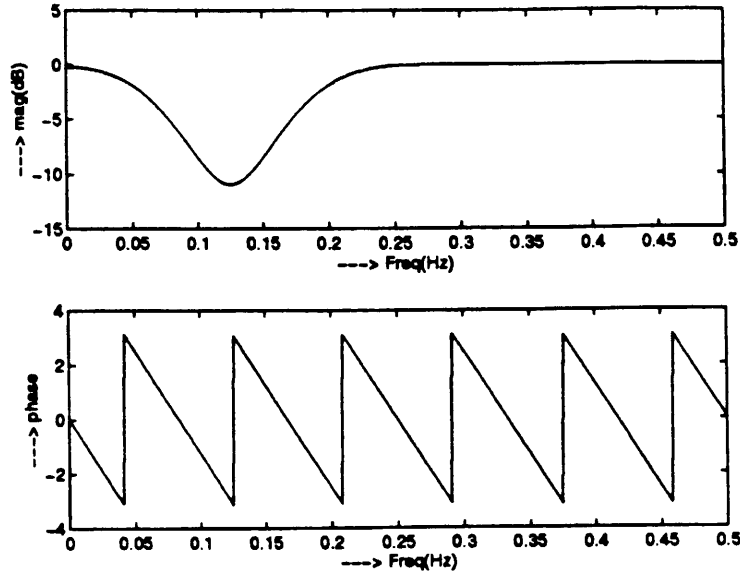

Figure 8.10:

$$\text{Hence, } H(z) = \frac{1 - rz^{-1}}{1 - 2r\cos\omega_0 z^{-1} + r^2 z^{-2}}, \quad \omega_0 = 0.3 \quad r = 0.99$$

From the impulse invariance method we obtain

$$\begin{aligned} H(s) &= \frac{1}{2} \left[\frac{1}{s + 0.1 - j3} + \frac{1}{s + 0.1 + j3} \right] \\ H(z) &= \frac{1}{2} \left[\frac{1}{1 - e^{-0.1T} e^{j3T} z^{-1}} + \frac{1}{1 - e^{-0.1T} e^{-j3T} z^{-1}} \right] \\ &= \frac{1 - r\cos\omega_0 z^{-1}}{1 - 2r\cos\omega_0 z^{-1} + r^2 z^{-2}} \end{aligned}$$

The poles are the same, but the zero is different.

8.11

$$\begin{aligned} H_a(s) &= \frac{(\Omega_u - \Omega_l)s}{s^2 - (\Omega_u - \Omega_l)s + \Omega_u\Omega_l} \\ s &= \frac{2}{T} \frac{1 - z^{-1}}{1 + z^{-1}} \\ H(z) &= (\Omega_u - \Omega_l) \frac{\frac{2}{T}(1 - z^{-1})(1 + z^{-1})}{\left(\frac{2}{T}\right)^2(1 - z^{-1})^2 + (\Omega_u - \Omega_l)\left(\frac{2}{T}\right)(1 - z^{-1})(1 + z^{-1}) + \Omega_u\Omega_l(1 + z^{-1})^2} \\ &= \frac{2(\alpha - \beta)(1 - z^{-2})}{[4 + 2(\alpha - \beta) + \alpha\beta] - 2(4 - \alpha\beta)z^{-1} + [4 - 2(\alpha - \beta) + \alpha\beta]z^{-2}} \end{aligned}$$

where $\alpha = \Omega_u T, \quad \beta = \Omega_l T$

In order to compare the result with example 8.3.2, let

$$\omega_u = \Omega_u T = \frac{3\pi}{5}$$

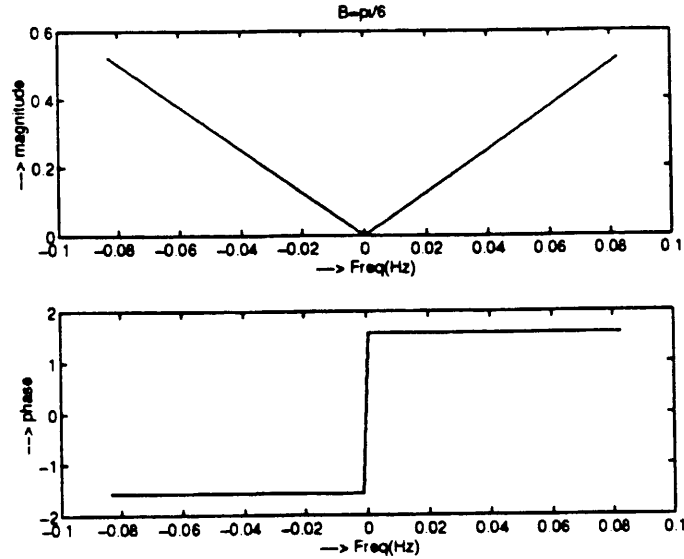

Figure 8.11:

$$\omega_l = \Omega_l T = \frac{2\pi}{5}$$

$$\text{Then, } H(z) = \frac{0.245(1 - z^{-2})}{1 + 0.509z^{-2}} \quad (\text{example 8.3.2})$$

$$\text{In our case, we have } \alpha = \Omega_u T = 2 \tan \frac{\omega_u}{2} = 2.753$$

$$\beta = \Omega_l T = 2 \tan \frac{\omega_l}{2} = 1.453$$

By substituting into the equation above, we obtain

$$\begin{aligned} H(z) &= \frac{2.599(1 - z^{-2})}{10.599 + 5.401z^{-2}} \\ &= \frac{0.245(1 - z^{-2})}{1 + 0.509z^{-2}} \end{aligned}$$

8.12

Let $T = 2$

$$(a) H(z) = \frac{1+z^{-1}}{1-z^{-1}} \Rightarrow y(n) = y(n-1) + x(n) + x(n-1)$$

(b)

$$H_a(\Omega) = \frac{1}{|\Omega|} \quad \angle H(\Omega) = \begin{cases} -\frac{\pi}{2}, & \Omega \geq 0 \\ \frac{\pi}{2}, & \Omega < 0 \end{cases}$$

(c)

$$|H(\omega)| = \left| \cot \frac{\omega}{2} \right| \quad \angle H(\omega) = \begin{cases} -\frac{\pi}{2}, & 0 \leq \omega \leq \pi \\ \frac{\pi}{2}, & -\pi < \omega < 0 \end{cases}$$

(d) The digital integrator closely matches the magnitude characteristics of the analog integrator. The two phase characteristics are identical.

(e) The integrator has a pole at $\omega = 0$. To avoid overflow problems, we would have $E[x(n)] = 0$, i.e., a signal with no dc component.

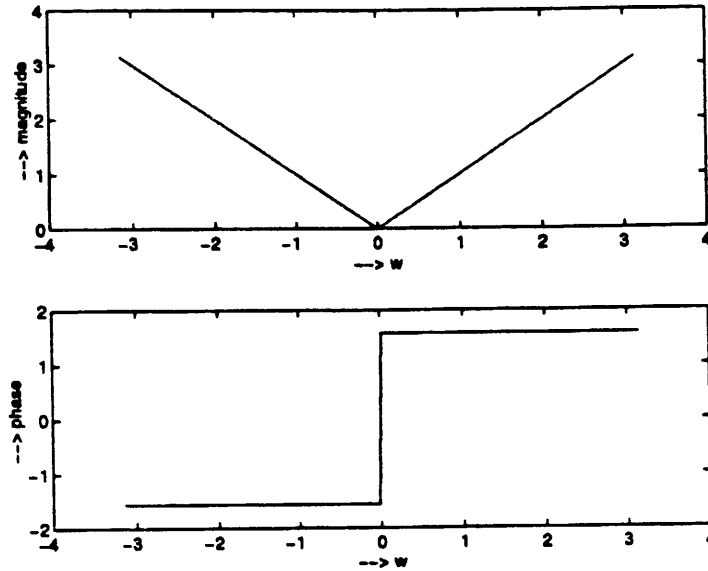

Figure 8.12:

8.13

(a)

$$\begin{aligned}
 H(z) &= A \frac{(1+z^{-1})^3}{(1-\frac{1}{2}z^{-1})(1-\frac{1}{2}z^{-1}+\frac{1}{4}z^{-2})} \\
 &= A \frac{(1+z^{-1})(1+2z^{-1}+z^{-2})}{(1-\frac{1}{2}z^{-1})(1-\frac{1}{2}z^{-1}+\frac{1}{4}z^{-2})} \\
 H(z)|_{z=1} &= 1 \\
 \Rightarrow A &= \frac{3}{64}, b_1 = 2, b_2 = 1, a_1 = 1, c_1 = -\frac{1}{2}, d_1 = -\frac{1}{2}, d_2 = \frac{1}{4}
 \end{aligned}$$

(b) Refer to fig 8.15

8.14

(a) There are only zeros, thus $H(z)$ is FIR.

(b)

$$\begin{aligned}
 \text{Zeros: } z_1 &= -\frac{4}{3}, \\
 z_2 &= -\frac{3}{4}, \\
 z_{3,4} &= \frac{3}{4}e^{\pm j\frac{\pi}{3}}, \\
 z_{5,6} &= \frac{4}{3}e^{\pm j\frac{\pi}{3}}, \\
 z_7 &= 1 \\
 \text{Hence, } z_2 &= \frac{1}{z_1}
 \end{aligned}$$

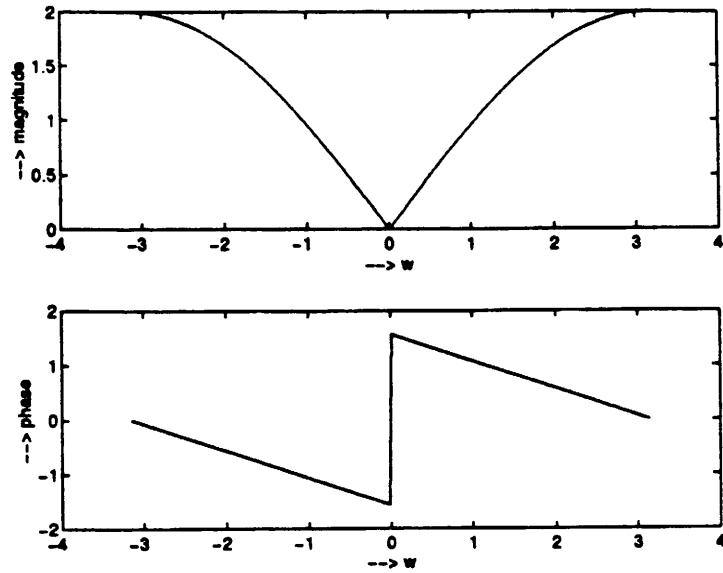

Figure 8.13:

$$\begin{aligned}
 z_4 &= z_3^* \\
 z_5 &= \frac{1}{z_3^*} \\
 z_6 &= z_5^* \\
 z_1 &= \frac{1}{z_7} = 1 \\
 \text{and } H(z) &= z^{-6} H(z^{-1})
 \end{aligned}$$

Therefore, $H(w)$ is linear phase.
(c) Refer to fig 8.16

8.15

From the design specifications we obtain

$$\begin{aligned}
 \epsilon &= 0.509 \\
 \delta &= 99.995 \\
 f_p &= \frac{4}{24} = \frac{1}{6} \\
 f_s &= \frac{6}{24} = \frac{1}{4} \\
 \text{Assume } t &= 1. \text{ Then, } \Omega_p = 2 \tan \frac{w_p}{2} \\
 &= 2 \tan \pi f_p = 1.155 \\
 \text{and } \Omega_s &= 2 \tan \frac{w_s}{2} \\
 &= 2 \tan \pi f_s = 2 \\
 \eta &= \frac{\delta}{\epsilon} = 196.5
 \end{aligned}$$

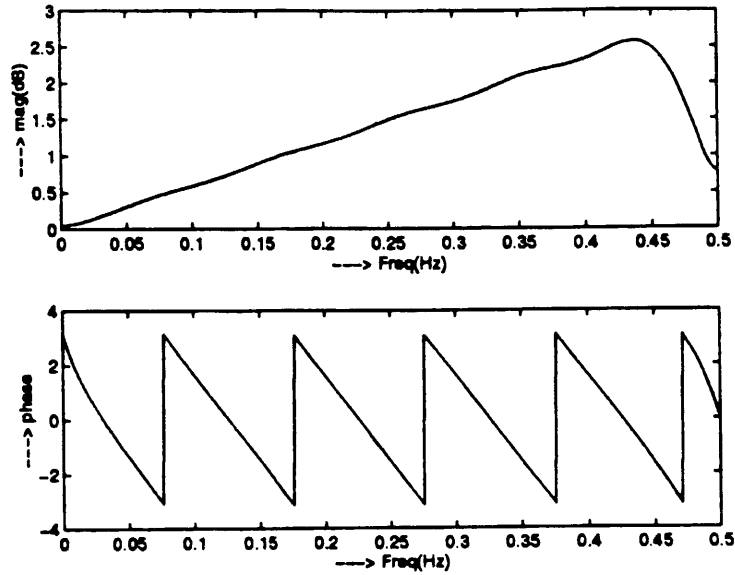

Figure 8.14:

$$k = \frac{\Omega_s}{\Omega_p} = 1.732$$

$$\text{Butterworth filter: } N_{\min} \geq \frac{\log \eta}{\log k} = 9.613 \Rightarrow N = 10$$

$$\text{Chebyshev filter: } N_{\min} \geq \frac{\cosh^{-1} \eta}{\cosh^{-1} k} = 5.212 \Rightarrow N = 6$$

$$\text{Elliptic filter: } \sin \alpha = \frac{1}{k} = 0.577 \Rightarrow \alpha = 35.3^\circ$$

$$\sin \beta = \frac{1}{\eta} = 0.577 \Rightarrow \beta = 0.3^\circ$$

$$N_{\min} \geq \frac{k(\sin \alpha)}{k(\cos \alpha)} \cdot \frac{k(\cos \beta)}{k(\sin \beta)} = 3.78 \Rightarrow N = 4$$

8.16

From the design specifications we have

$$\epsilon = 0.349$$

$$\delta = 99.995$$

$$f_p = \frac{1.2}{8} = 0.15$$

$$f_s = \frac{2}{8} = 0.25$$

$$\Omega_p = 2 \tan \frac{\omega_p}{2} = 1.019$$

$$\Omega_s = 2 \tan \frac{\omega_s}{2} = 2$$

$$\eta = \frac{\delta}{\epsilon} = 286.5$$

$$k = \frac{\Omega_s}{\Omega_p} = 1.963$$

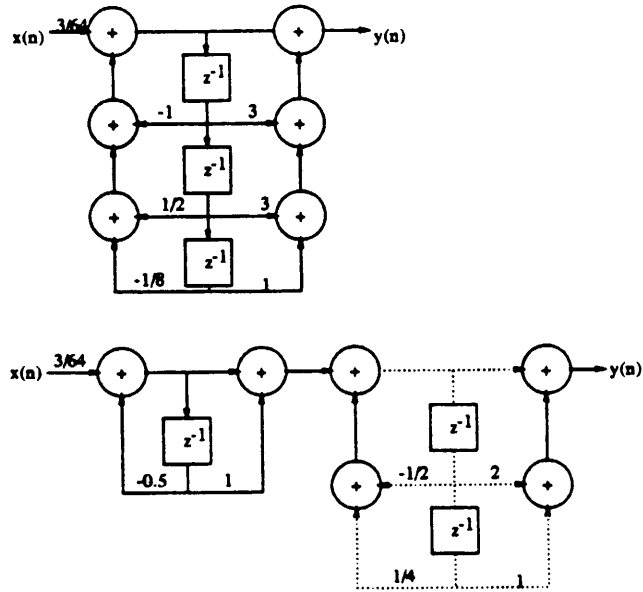

Figure 8.15:

$$\text{Butterworth filter: } N_{\min} \geq \frac{\log \eta}{\log k} = 8.393 \Rightarrow N = 9$$

$$\text{Chebyshev filter: } N_{\min} \geq \frac{\cosh^{-1} \eta}{\cosh^{-1} k} = 4.90 \Rightarrow N = 5$$

$$\text{Elliptic filter: } N_{\min} \geq \frac{k(\frac{1}{k})}{k(\sqrt{1 - \frac{1}{k^2}})} \cdot \frac{k(\sqrt{1 - \frac{1}{\eta^2}})}{k(\frac{1}{\eta})} \Rightarrow N = 4$$

8.17

$$\text{Passband ripple} = 1\text{dB} \Rightarrow \epsilon = 0.509$$

$$\text{Stopband attenuation} = 60\text{dB} \Rightarrow \delta = 1000$$

$$\omega_p = 0.3\pi$$

$$\omega_s = 0.35\pi$$

$$\Omega_p = 2 \tan \frac{\omega_p}{2} = 1.019$$

$$\Omega_s = 2 \tan \frac{\omega_s}{2} = 1.226$$

$$\eta = \frac{\delta}{\epsilon} = 1965.226$$

$$k = \frac{\Omega_s}{\Omega_p} = 1.203$$

$$N_{\min} \geq \frac{\cosh^{-1} \eta}{\cosh^{-1} k} = \frac{8.277}{0.627} = 13.2 \Rightarrow N = 14$$

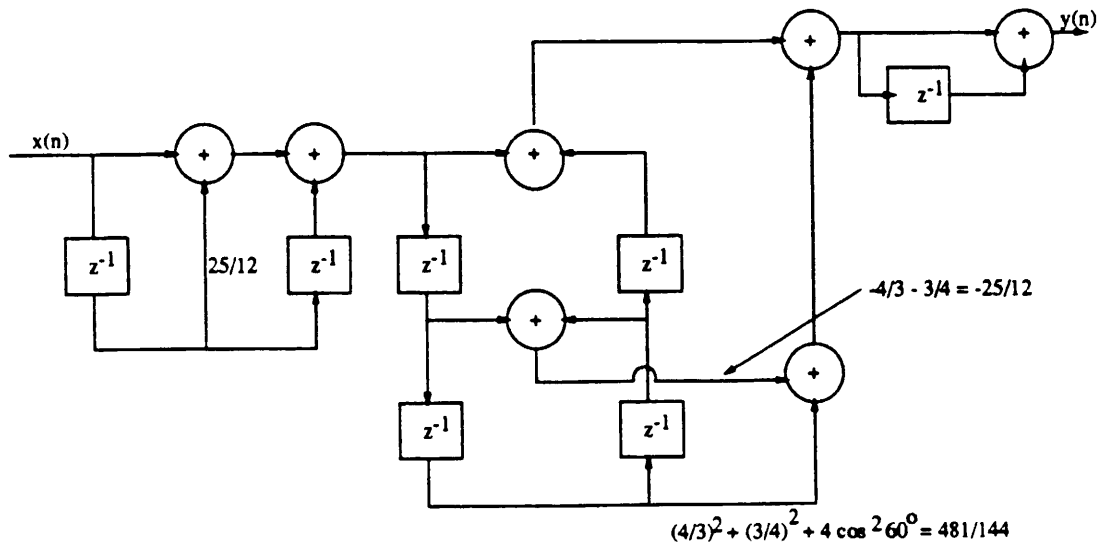

Figure 8.16:

Special software package, such as MATLAB or PC-DSP may be used to obtain the filter coefficients. Hand computation of these coefficients for $N = 14$ is very tedious.

8.18

Passband ripple = 0.5dB $\Rightarrow \epsilon = 0.349$
 Stopband attenuation = 50dB

$$\begin{aligned}
 \omega_p &= 0.24\pi \\
 \omega_s &= 0.35\pi \\
 \Omega_p &= 2 \tan \frac{\omega_p}{2} = 0.792 \\
 \Omega_s &= 2 \tan \frac{\omega_s}{2} = 1.226 \\
 \eta &= \frac{\delta}{\epsilon} = 906.1 \\
 k &= \frac{\Omega_s}{\Omega_p} = 1.547 \\
 N_{\min} &\geq \frac{\cosh^{-1} \eta}{\cosh^{-1} k} = \frac{7.502}{1.003} = 7.48 \Rightarrow N = 8
 \end{aligned}$$

Use a computer software package to determine the filter coefficients.

8.19

(a) MATLAB is used to design the FIR filter using the Remez algorithm. We find that a filter of length $N = 37$ meets the specifications. We note that in MATLAB, the frequency scale is normalized to $\frac{1}{2}$ of the sampling frequency. Refer to fig 8.17.

(b) $\delta_1 = 0.02$, $\delta_2 = 0.01$, $\Delta f = \frac{20}{100} - \frac{15}{100} = 0.05$

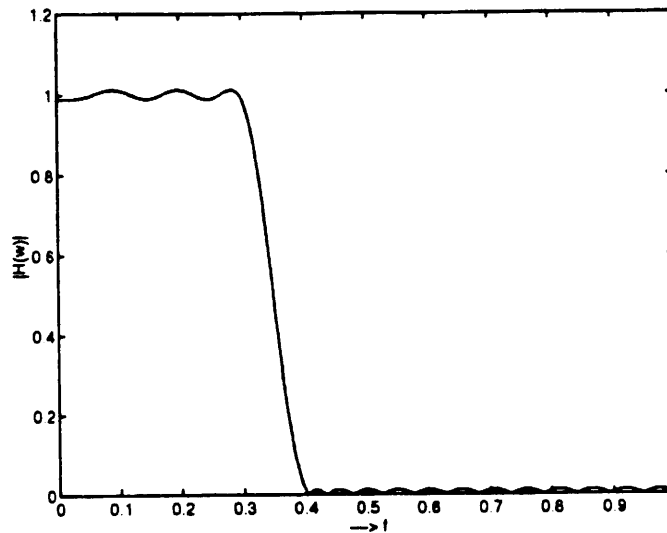

Figure 8.17:

With equation (8.2.94) we obtain

$$\hat{M} = \frac{-20 \log_{10}(\sqrt{\delta_1 \delta_2}) - 13}{14.6 \Delta f} + 1 \approx 34$$

With equation (8.2.95) we obtain

$$D_{\infty}(\delta_1 \delta_2) = 1.7371$$

$$f(\delta_1 \delta_2) = 11.166$$

$$\text{and } \hat{M} = \frac{D_{\infty}(\delta_1 \delta_2) - f(\delta_1 \delta_2)(\Delta f)^2}{\Delta f} + 1 \approx 36$$

Note (8.2.95) is a better approximation of M .

(c) Refer to fig 8.18.

Note that this filter does not satisfy the specifications.

(d) The elliptic filter satisfies the specifications. Refer to fig 8.19.

(e)

	FIR	IIR
order	37	5
storage	19	16
No. of mult.	19	16

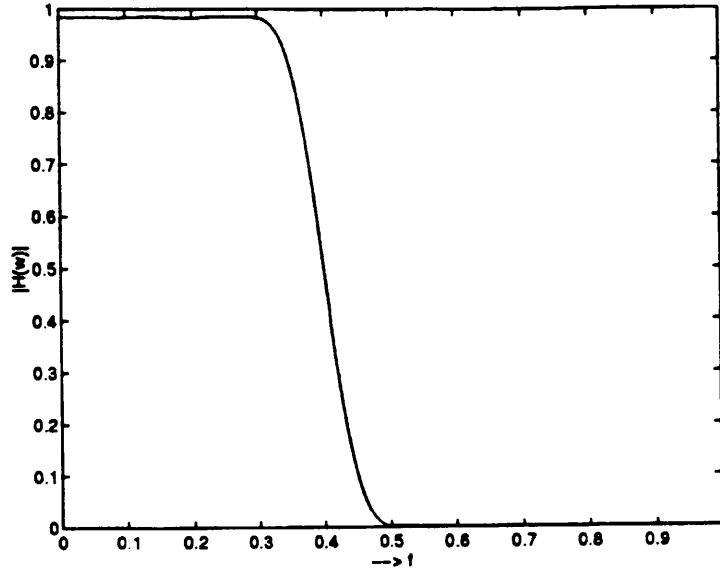

Figure 8.18: M=37 FIR filter designed by window method with Hamming window

8.20

(a)

$$h(n) = \left\{ \underset{\uparrow}{0}, 1, 2, 3, 4, 5, 4, 3, 2, 1, 0, \dots \right\}$$

$$\begin{aligned} H(z) &= \sum_{n=0}^{10} h(n)z^{-n} \\ &= z^{-1} + 2z^{-2} + 3z^{-3} + 4z^{-4} + 5z^{-5} + 4z^{-6} + 3z^{-7} + 2z^{-8} + z^{-9} \\ H(w) &= e^{-j9w} [2\cos 4w + 4\cos 3w + 6\cos 2w + 8\cos w + 5] \end{aligned}$$

(b) $|H(w)| = |2\cos 4w + 4\cos 3w + 6\cos 2w + 8\cos w + 5|$. Refer to fig 8.20.

(c)

$$\begin{aligned} b_0 &= h(1) = 1 \\ r_{hh}(0) &= \sum_{n=1}^9 h^2(n) = 85 \\ r_{hh}(1) &= \sum_{n=1}^8 h(n)h(n+1) = 80 \\ r_{hh}(2) &= \sum_{n=1}^7 h(n)h(n+2) = 68 \end{aligned}$$

$$\begin{bmatrix} r_{hh}(0) & r_{hh}(1) \\ r_{hh}(1) & r_{hh}(0) \end{bmatrix} \begin{bmatrix} a_1 \\ a_2 \end{bmatrix} = \begin{bmatrix} -r_{hh}(1) \\ -r_{hh}(2) \end{bmatrix} \Rightarrow a_1 = -\frac{272}{165}, a_2 = \frac{124}{165}$$

8.21

(a)

$$\text{dc gain: } H_a(0) = 1$$

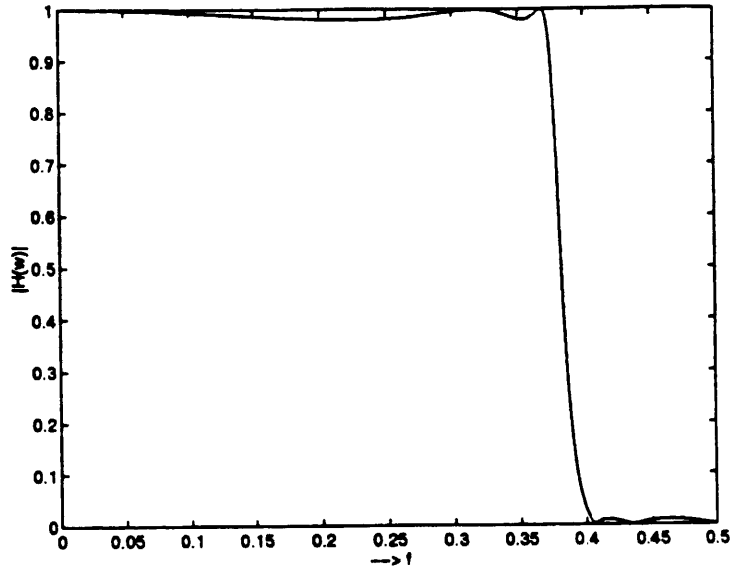

Figure 8.19:

$$\text{3dB frequency: } |H_a(j\Omega)|^2 = \frac{1}{2}$$

$$\text{or } \frac{\alpha^2}{\alpha^2 + \Omega_c^2} = \frac{1}{2}$$

$$\Rightarrow \Omega_c = \alpha$$

$$\text{For all } \Omega, \text{ only } H(j\infty) = 0$$

$$h_a(\tau) = \frac{1}{e} h_a(0) = \frac{1}{e}$$

$$\Rightarrow e^{-\alpha\tau} = e^{-1}$$

$$\Rightarrow \tau = \frac{1}{\alpha}$$

(b)

$$h(n) = h_a(nT) = e^{-\alpha nT} u(n)$$

$$H(z) = \frac{1}{1 - e^{-\alpha T} z^{-1}}$$

$$H(w) = \frac{1}{1 - e^{-\alpha T} e^{-jw}}$$

$$H(0) = H(w)|_{w=0}$$

$$= \frac{1}{1 - e^{-\alpha T}}$$

$$\text{3dB frequency: } |H(w_c)|^2 = \frac{1}{2} |H(0)|^2$$

$$(1 - \alpha^T \alpha \cos w_c)^2 + (e^{-\alpha T} \sin w_c)^2 = 2(1 - e^{-\alpha T})^2$$

$$\text{Hence, } w_c = 2 \sin^{-1} \left(\sinh \frac{\alpha T}{2} \right)$$

$$\text{Since } |H(w)|^2 = \frac{1}{1 - 2e^{-\alpha T} \cos w + e^{-2\alpha T}}$$

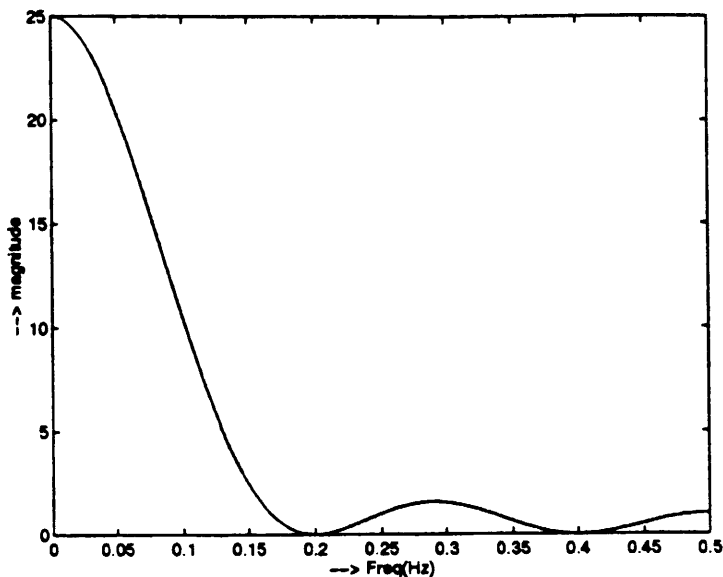

Figure 8.20:

it oscillates between $\frac{1}{(1 - e^{-\alpha T})^2}$ and $\frac{1}{(1 + e^{-\alpha T})^2}$
but never reaches zero

$$h(\tau) = e^{-\alpha \tau T} = e^{-1}$$

$$\Rightarrow \tau \geq \frac{1}{\alpha T}$$

τ is the smallest integer that is larger than $\frac{1}{T}$

(c)

$$\begin{aligned} H(z) &= \frac{\alpha}{\frac{2}{T} \frac{1-z^{-1}}{1+z^{-1}} + \alpha} \\ &= \frac{\alpha T(1+z^{-1})}{2(1-z^{-1}) + \alpha T(1+z^{-1})} \\ &= \frac{\alpha T(1+z^{-1})}{2 + \alpha T + (\alpha T - 2)z^{-1}} \end{aligned}$$

$$\text{DC Gain: } H(z)|_{z=1} = 1$$

$$\text{At } z = -1 (w = \pi), H(z) = 0$$

$$\text{since } |H_a(j\Omega_c)|^2 = \frac{1}{2}, \text{ we have } \Omega_c = \alpha$$

$$\omega_c = 2 \tan^{-1} \frac{\Omega_c T}{2}$$

$$= 2 \tan^{-1} \alpha T$$

$$\text{Let } a = \frac{2 - \alpha T}{2 + \alpha T}$$

$$\text{Then } H(z) = \frac{1-a}{2} \left[1 + \frac{(1+a)z^{-1}}{1-az^{-1}} \right]$$

$$h(n) = \frac{1-a}{2} [\delta(n) + (1+a)a^{n-1}u(n-1)]$$

$$\begin{aligned}
h(0) &= \frac{1-a}{2} \\
\frac{h(n)}{h(0)} &= \frac{1}{e} \\
\Rightarrow (1+a)a^{n-1} &= \frac{1}{e} \\
n &= \frac{\ln \frac{1}{1+a} - 1}{\ln a} \\
&= \frac{\ln \left(\frac{2-\alpha T}{4} \right) - 1}{\ln \left(\frac{2-\alpha T}{2+\alpha T} \right)}
\end{aligned}$$

8.22

(a)

$$\begin{aligned}
h_d(n) &= \frac{T}{2\pi} \int_{-\frac{\pi}{T}}^{\frac{\pi}{T}} H_d(w) e^{jwn} dw \\
&= \frac{T}{2\pi} \left[\int_{-\frac{\pi}{T}}^{-\frac{0.4\pi}{T}} e^{jwn} dw + \int_{\frac{0.4\pi}{T}}^{\frac{\pi}{T}} e^{jwn} dw \right] \\
&= \frac{T}{n\pi} \left[\sin \frac{\pi n}{2T} - \sin \frac{2\pi n}{5T} \right]
\end{aligned}$$

(b)

Let $h_s(n) = h_d(n)w(n)$, $-100 \leq n \leq 100 (M = 101)$
Then, $h(n) = h_s(n - 100)$ will be the impulse of the filter for $0 \leq n \leq 200$

(c)

$$H_d(w) = \begin{cases} 0, & 0 \leq w \leq \frac{0.4\pi}{T} \\ e^{-j100w}, & \frac{0.4\pi}{T} \leq w \leq \frac{0.5\pi}{T} \\ 0, & \frac{0.5\pi}{T} \leq w \leq \frac{1.5\pi}{T} \\ e^{-j100w}, & \frac{1.5\pi}{T} \leq w \leq \frac{1.6\pi}{T} \\ 0, & \frac{1.6\pi}{T} \leq w \leq \frac{2\pi}{T} \end{cases}$$

$$\begin{aligned}
w &= \frac{2\pi}{200} k \\
&= \frac{\pi k}{100T} \\
\text{Then, } H(k) &= 0, \quad 0 \leq k < 40 \\
&= 0, \quad 50 < k < 150 \\
&= 0, \quad 160 < k \leq 200 \\
H(k) &= e^{-\frac{j\pi k}{T}}, \quad 40 \leq k \leq 50 \\
&= e^{-j\pi k T}, \quad 150 \leq k \leq 160
\end{aligned}$$

$H(w)$ will match $H_d(w)$ at 201 points in frequency. The filter will contain large ripples in between the sampled frequencies. Transition values should be specified to reduce the ripples in both the passbands and the stopband.

8.23

(a)

$$\begin{aligned} \omega_l &= \frac{5\pi}{12} \\ \Omega_l &= \tan \frac{\omega_l}{2} \quad (\text{for } T = 2) \\ \omega_u &= \frac{7\pi}{12} \\ \Omega_u &= \tan \frac{\omega_u}{2} \end{aligned}$$

Analog: lowpass to bandpass

$$s \rightarrow \frac{s^2 + \Omega_l \Omega_u}{s(\Omega_u - \Omega_l)}$$

Bilinear: Analog to digital

$$s \rightarrow \frac{z-1}{z+1} = \frac{1-z^{-1}}{1+z^{-1}}$$

combine the two steps:

$$\begin{aligned} s &\rightarrow \frac{\left(\frac{1-z^{-1}}{1+z^{-1}}\right)^2 + \Omega_l \Omega_u}{\frac{1-z^{-1}}{1+z^{-1}}(\Omega_u - \Omega_l)} \\ &= \frac{(1-z^{-1})^2 + \Omega_u \Omega_l (1+z^{-1})^2}{(1-z^{-1})(\Omega_u - \Omega_l)} \end{aligned}$$

$$\text{Therefore, } H(z) = \frac{1}{\left[\frac{(1-z^{-1})^2 + \Omega_u \Omega_l (1+z^{-1})^2}{(1-z^{-2})(\Omega_u - \Omega_l)}\right]^2 + \sqrt{2} \left[\frac{(1-z^{-1})^2 + \Omega_u \Omega_l (1+z^{-1})^2}{(1-z^{-2})(\Omega_u - \Omega_l)}\right] + 1}$$

(b)

$$\begin{aligned} \frac{\Omega_u}{\Omega_l} &= \frac{\tan \frac{7\pi}{24}}{\tan \frac{5\pi}{24}} = 1.7 \\ (1) \frac{\Omega_u}{\Omega_l} &= 1.43 \\ (2) \frac{\Omega_u}{\Omega_l} &= 1.8 \\ (3) \frac{\Omega_u}{\Omega_l} &= 1.82 \\ (4) \frac{\Omega_u}{\Omega_l} &= 1.7 \end{aligned}$$

filter (4) satisfies the constraint

8.24

(a)

$$\begin{aligned} H(z) &= (1-z^{-12}) \left[\frac{\frac{1}{6}}{1+z^{-1}} + \frac{\frac{1}{12}(1-\frac{1}{2}z^{-1})}{1-z^{-1}+z^{-2}} + \frac{\frac{1}{12}(1+\frac{1}{2}z^{-1})}{1+z^{-1}+z^{-2}} \right] \\ &= \frac{1}{6}(1-z^{-12}) \left[\frac{2+z^{-1}+\frac{3}{2}z^{-2}+\frac{1}{2}z^{-3}+z^{-4}}{1+z^{-1}+z^{-2}+z^{-3}+z^{-4}+z^{-5}} \right] \\ &= \frac{1}{6}(1-z^{-6})(1-z^{-1})(2+z^{-1}+\frac{3}{2}z^{-2}+\frac{1}{2}z^{-3}+z^{-4}) \end{aligned}$$

This filter is FIR with zeros at $z = 1, e^{\pm j\frac{\pi}{6}}, e^{\pm j\frac{2\pi}{3}}, e^{\pm j\frac{5\pi}{6}}, -0.5528 \pm j0.6823$ and $0.3028 \pm j0.7462$

(b) It is a highpass filter.

(c)

$$H(\omega) = \frac{1}{6}(1 - e^{-j6\omega})(1 - e^{-j\omega})(2 + e^{-j\omega} + \frac{3}{2}e^{-j2\omega} + \frac{1}{2}e^{-j3\omega} + e^{-j4\omega})$$

$$H(0) = H(\frac{\pi}{6}) = H(\frac{3\pi}{6}) = H(\frac{3\pi}{6}) = 0$$

$$H(\frac{2\pi}{6}) = \frac{1}{2}$$

$$H(\frac{4\pi}{6}) = 2$$

$$H(\pi) = 2$$

8.25

(a)

$$f_L = \frac{900}{2500} = 0.36$$

$$f_H = \frac{1100}{2500} = 0.44$$

Refer to fig 8.21.

(b) The ideal lowpass filter has a passband of $-0.04 \leq f \leq 0.04$. Hence,

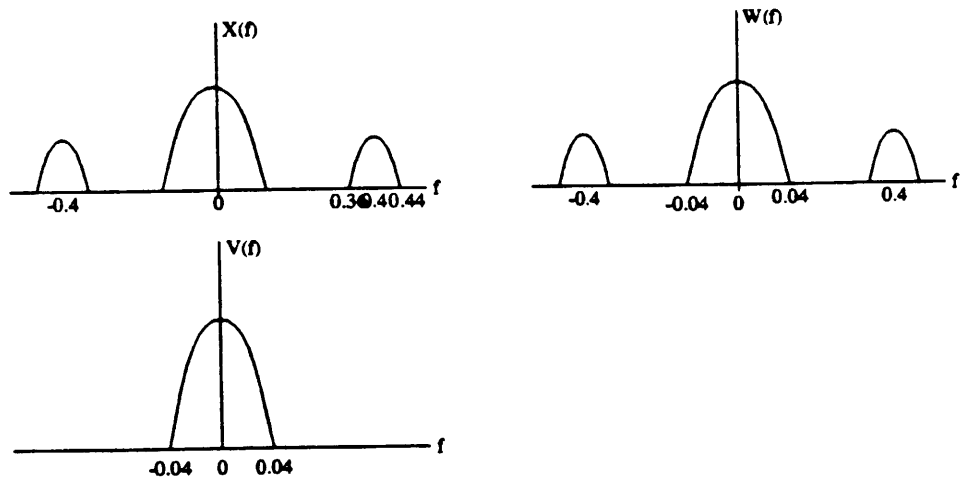

Figure 8.21:

$$H_d(\omega) = \begin{cases} 1e^{-j15\omega} & -0.08\pi \leq \omega \leq 0.08\pi \\ 0, & \text{otherwise} \end{cases}$$

Hence,

$$h_d(n) = \frac{1}{2\pi} \int_{-0.08\pi}^{0.08\pi} e^{-j15\omega} e^{j\omega n} d\omega$$

$$\begin{aligned}
&= \frac{1}{2\pi} \int_{-0.08\pi}^{0.08\pi} e^{jw(n-15)} dw \\
&= \frac{2\sin 0.08\pi(n-15)}{(n-15)} \\
h(n) &= h_d(n)w_H(n) \\
w_H(n) &= 0.54 - 0.46\cos \frac{2\pi(n-15)}{30}
\end{aligned}$$

$h(n)$ is the impulse response of the lowpass filter $H(w)$

8.26

$$\begin{aligned}
r_{dh}(0) &= \sum_{n=0}^{\infty} \delta(n-2)h(n) = 0 \\
r_{dh}(1) &= \sum_{n=0}^{\infty} \delta(n-2)h(n-1) = h(1) = -0.5 \\
r_{dh}(2) &= \sum_{n=0}^{\infty} \delta(n-2)h(n-2) = h(0) = 1
\end{aligned}$$

Therefore,

$$\begin{bmatrix} 1.25 & -0.5 & 0 \\ -0.5 & 1.25 & -0.5 \\ 0 & -0.5 & 1.25 \end{bmatrix} \begin{bmatrix} b_0 \\ b_1 \\ b_2 \end{bmatrix} = \begin{bmatrix} 0 \\ -0.5 \\ 1 \end{bmatrix}$$

$$\begin{aligned}
b_0 &= -0.0471 \\
b_1 &= -0.1176 \\
b_2 &= 0.7529 \\
E_{min} &= \sum_{n=0}^{\infty} d^2(n) - \sum_{k=0}^{\infty} b_k r_{dh}(k) \\
&= 1 - [0.7529 + \frac{1}{2}(0.1176)] \\
&= 0.1883
\end{aligned}$$

8.27

$$x(n) = \sum_{k=0}^{N-1} e^{j2\pi kn/N} = \begin{cases} N, & n=0 \\ 0, & 1 \leq n \leq N-1 \end{cases}$$

$x(n)$ is a periodic sequence with period N . Hence, $y(n)$ is also periodic with period N . Let

$$\begin{aligned}
H_2(z) &= 1 + \sum_{k=1}^p a_k z^{-k} \\
\text{and } h_2(n) &= \{1, a_1, a_2, \dots, a_p\} \\
\text{Then, } h_2(n) * y(n) &= x(n), \quad n = 0, 1, \dots, N-1
\end{aligned}$$

If $p + 1 \leq N$, the N equations above are sufficient to determine a_1, a_2, \dots, a_p and their order. If $p + 1 > N$, it is not possible to determine the $\{a_k\}$ and the order p .
(c)

$$\begin{aligned} \text{Let } h_1(n) &= \left\{ \begin{matrix} b_0, b_1, \dots, b_N \\ \uparrow \\ 1 \end{matrix} \right\} \\ \text{and } h_2(n) &= \{1, a_1, \dots, a_p\} \\ \text{Then, } h_1(n) * x(n) &= h_2(n) * y(n) \end{aligned}$$

If $h_1(n)$ is known, then $w(n) = h_1(n)x(n)$ is also a periodic signal with period N . If $N \geq p + 1$, then $h_2(n)$ or a_1, a_2, \dots, a_p can be determined by the above equation. If either $N < p + 1$ or $h_1(n)$ is not known, then, it is not possible to determine the filter parameters. (d) (1) The set of linear equations are:

$$\sum_{k=0}^{M-1} h(k)r_{xx}(k-l) = r_{yx}(l), \quad l = 0, 1, \dots, M-1$$

$$\text{where } r_{xx}(l) = \sum_{n=0}^{\infty} x(n)x(n-l) \text{ and}$$

$$r_{yx}(l) = \sum_{n=0}^{\infty} y(n)x(n-l)$$

$$E = \sum_{n=-\infty}^{\infty} \left[y(n) - \sum_{k=0}^{M-1} h(k)x(n-k) \right]^2$$

(2) Refer to fig 8.22.

(3) Refer to fig 8.23.

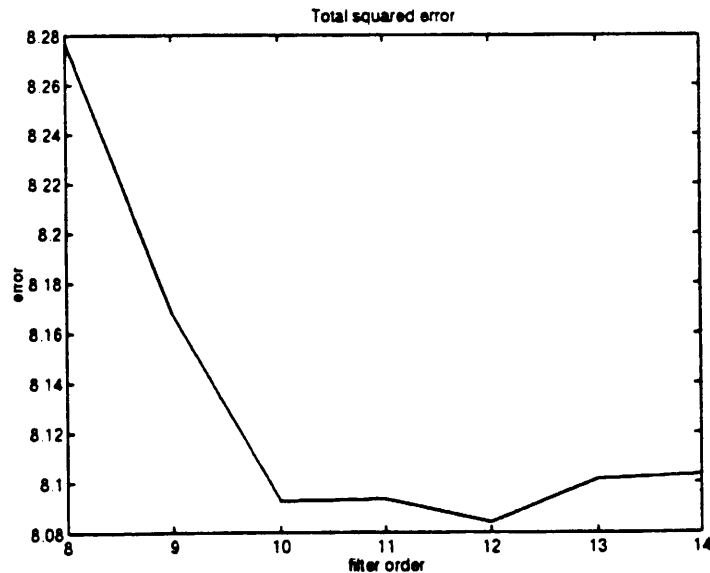

Figure 8.22:

(4) $v(n) = y(n) + 0.01w(n)$. Refer to fig 8.24.

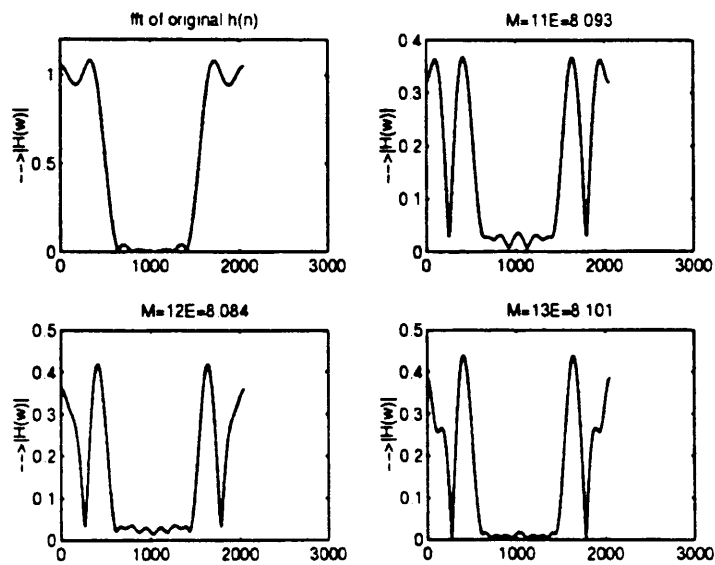

Figure 8.23:

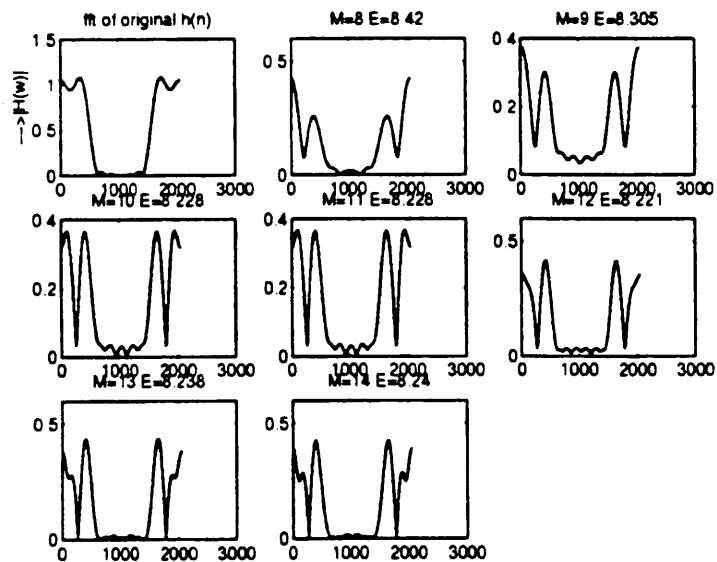

Figure 8.24:

Chapter 9

9.1

Since $\frac{F_c + \frac{B}{2}}{B} = \frac{50+10}{20} = 3$ is an integer, then $F_s = 2B = 40\text{Hz}$

9.2

$$\begin{aligned} F_c &= 100 \\ B &= 12 \\ r &= \left\lceil \frac{F_c + \frac{B}{2}}{B} \right\rceil \\ &= \left\lceil \frac{106}{12} \right\rceil \\ &= \lceil 8.83 \rceil = 8 \\ B' &= \frac{F_c + \frac{B}{2}}{r} \\ &= \frac{106}{8} \\ &= \frac{53}{4} \\ F_s &= 2B' \\ &= \frac{53}{2} \text{ Hz} \end{aligned}$$

9.3

$$x_l(t) = [x(t) + j\hat{x}(t)]e^{-j2\pi f_c t}$$

Since $[x(t) + j\hat{x}(t)]$ is complex, $x_l(t)$ is complex. The condition for $x_l(t)$ to be real is $X_l(f) = X_l^*(-f)$.

9.4

(a)

$$\begin{aligned} x(n) &\leftrightarrow X(w) \\ x^2(n) &\leftrightarrow X(w) * X(w) \end{aligned}$$

The output $y_1(t)$ is basically the square of the input signal $y_a(t)$. For the second system,

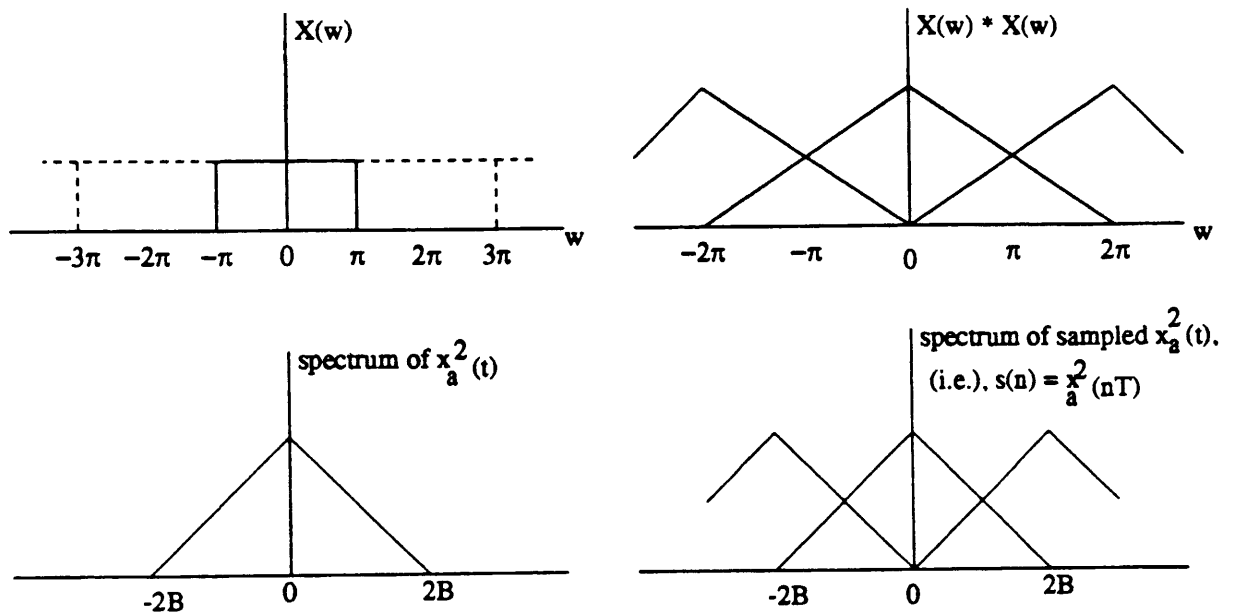

Figure 9.1:

$x_a^2(t) \leftrightarrow X(w) * X(w)$, the bandwidth is basically $2B$. The spectrum of the sampled signal is given in fig refprob9.4a.

(b)

$$\begin{aligned}
 x_a(t) &= \cos 40\pi t \\
 x(n) &= \cos \frac{40\pi n}{50} \\
 &= \cos \frac{4\pi n}{5} \\
 y(n) &= x^2(n) \\
 &= \cos^2 \frac{4\pi n}{5} \\
 &= \frac{1}{2} + \frac{1}{2} \cos \frac{8\pi n}{5} \\
 &= \frac{1}{2} + \frac{1}{2} \cos \frac{2\pi n}{5} \\
 y_1(t) &= \frac{1}{2} + \frac{1}{2} \cos 20\pi t \\
 s_a(t) &= x_a^2(t) \\
 &= \cos^2 40\pi t \\
 &= \frac{1}{2} + \frac{1}{2} \cos 80\pi t \\
 s(n) &= \frac{1}{2} + \frac{1}{2} \cos \frac{80\pi n}{50}
 \end{aligned}$$

$$\begin{aligned}
&= \frac{1}{2} + \frac{1}{2} \cos \frac{8\pi n}{5} \\
&= \frac{1}{2} + \frac{1}{2} \cos \frac{2\pi n}{5} \\
\text{Hence, } y_2(t) &= \frac{1}{2} + \frac{1}{2} \cos 20\pi t \\
\text{For } F_s &= 30, \\
x(n) &= \cos \frac{4\pi n}{3} \\
&= \cos \frac{2\pi n}{3} \\
y(n) &= x^2(n) \\
&= \cos^2 \frac{2\pi n}{3} \\
&= \frac{1}{2} + \frac{1}{2} \cos \frac{4\pi n}{3} \\
&= \frac{1}{2} + \frac{1}{2} \cos \frac{2\pi n}{3} \\
y_1(t) &= \frac{1}{2} + \frac{1}{2} \cos 20\pi t \\
s_a(t) &= x_a^2(t) \\
&= \cos^2 40\pi t \\
&= \frac{1}{2} + \frac{1}{2} \cos 80\pi t \\
s(n) &= \frac{1}{2} + \frac{1}{2} \cos \frac{80\pi n}{30} \\
&= \frac{1}{2} + \frac{1}{2} \cos \frac{2\pi n}{3} \\
\text{Hence, } y_2(t) &= \frac{1}{2} + \frac{1}{2} \cos 20\pi t
\end{aligned}$$

9.5

$$\begin{aligned}
s_a(t) &= x_a(t) + \alpha x_a(t - \tau), \quad |\alpha| < 1 \\
s_a(n) &= x_a(n) + \alpha x_a(n - \frac{\tau}{T}) \\
\frac{S_a(w)}{X_a(w)} &= 1 + \alpha e^{-j\omega \frac{\tau}{T}}
\end{aligned}$$

If $\frac{\tau}{T}$ is an integer, then we may select

$$H(z) = \frac{1}{1 - \alpha z^{-2}} \text{ where } \frac{\tau}{T} = L$$

9.6

$$\begin{aligned}
\sum_{n=-\infty}^{\infty} x^2(n) &= \frac{1}{2\pi} \int_{-\pi}^{\pi} |X(w)|^2 dw \\
X(w) &= \frac{1}{T} \sum_{k=-\infty}^{\infty} X_a \left(\frac{w - 2\pi k}{T} \right)
\end{aligned}$$

$$\begin{aligned}
&= \frac{1}{T} \sum_{k=-\infty}^{\infty} X_a\left(\frac{\omega}{T}\right), \quad |\omega| \leq \pi \\
\sum_{n=-\infty}^{\infty} x^2(n) &= \frac{1}{2\pi} \int_{-\pi}^{\pi} \frac{1}{T^2} |X_a\left(\frac{\omega}{T}\right)|^2 d\omega \\
&= \frac{1}{2\pi T^2} \int_{-\frac{\pi}{T}}^{\frac{\pi}{T}} |X_a(\lambda)|^2 T d\lambda \\
&= \frac{1}{2\pi T} \int_{-\frac{\pi}{T}}^{\frac{\pi}{T}} |X_a(\lambda)|^2 d\lambda
\end{aligned}$$

$$\begin{aligned}
\text{Also, } E_a &= \int_{-\infty}^{\infty} x_a^2(t) dt \\
&= \int_{-\infty}^{\infty} |X_a(f)|^2 df \\
&= \int_{-\frac{f_s}{2}}^{\frac{f_s}{2}} |X_a(f)|^2 df
\end{aligned}$$

$$\text{Therefore, } \sum_{n=-\infty}^{\infty} x^2(n) = \frac{E_a}{T}$$

9.7

(a)

$$\begin{aligned}
d(n) &= x(n) - ax(n-1) \\
E[d(n)] &= E[x(n)] - aE[x(n-1)] = 0 \\
E[d^2(n)] \equiv \sigma_d^2 &= E\{[x(n) - ax(n-1)]^2\} \\
&= \sigma_x^2 + a^2\sigma_x^2 - 2aE[x(n)x(n-1)] \\
&= \sigma_x^2 + a^2\sigma_x^2 - 2a\gamma_x(1) \\
&= \sigma_x^2(1 + a^2 - 2a\rho_x(1)) \\
\text{where } \rho_x(1) &= \frac{\gamma_x(1)}{\sigma_x^2} \\
&\equiv \frac{\gamma_x(1)}{\gamma_x(0)}
\end{aligned}$$

(b)

$$\begin{aligned}
\frac{d}{da} [\sigma_x^2(1 + a^2 - 2a\rho_x(1))] &= 2a - 2\rho_x(1) = 0 \\
a &= \rho_x(1)
\end{aligned}$$

For this value of α we have

$$\begin{aligned}
\sigma_d^2 &= \sigma_x^2[1 + \rho_x^2(1) - 2\rho_x^2(1)] \\
&= \sigma_x^2[1 - \rho_x^2(1)]
\end{aligned}$$

(c) $\sigma_d^2 < \sigma_x^2$ is always true if $|\rho_x(1)| > 0$. Note also that $|\rho_x(1)| \leq 1$.

(d)

$$\begin{aligned}
d(n) &= x(n) - a_1x(n-1) - a_2x(n-2) \\
E[d^2(n)] &= E\{[x(n) - a_1x(n-1) - a_2x(n-2)]^2\}
\end{aligned}$$

$$\begin{aligned} \sigma_d^2 &= \sigma_x^2(1 + a_1^2 + a_2^2 + 2a_1(a_2 - 1)\rho_x(1) - 2a_2\rho_x(2)) \\ \frac{d}{da_1}\sigma_d^2 &= 0 \\ \Rightarrow a_1 &= \frac{\rho_x(1)[1 - \rho_x(2)]}{1 - \rho_x^2(1)} \\ \frac{d}{da_2}\sigma_d^2 &= 0 \\ \Rightarrow a_2 &= \frac{\rho_x(2) - \rho_x^2(1)}{1 - \rho_x^2(1)} \\ \text{Then, } \sigma_{d\min}^2 &= \frac{1 - 3\rho_x^2(1) - \rho_x^2(2) + 2\rho_x^2(1)\rho_x(2) + 2\rho_x^4(1) + \rho_x^2(1)\rho_x^2(2) - 2\rho_x^4(1)\rho_x(2)}{[1 - \rho_x^2(1)]^2} \end{aligned}$$

9.8

$$\begin{aligned} x(t) &= A\cos 2\pi Ft \\ \frac{dx(t)}{dt} &= -A(2\pi F)\sin 2\pi Ft \\ &= -2\pi AF\sin 2\pi Ft \\ \left.\frac{dx(t)}{dt}\right|_{\max} &= 2\pi AF \leq \frac{\Delta}{T} \\ \text{Hence, } \Delta &\geq 2\pi AFT \\ &= \frac{2\pi AF}{F_s} \end{aligned}$$

Refer to fig 9.2.

9.9

Let P_d denote the power spectral density of the quantization noise. Then (a)

$$\begin{aligned} P_n &= \int_{-\frac{F_s}{2}}^{\frac{F_s}{2}} P_d df \\ &= \frac{2B}{F_s} P_d \\ &= \sigma_e^2 \\ \text{SQNR} &= 10\log_{10} \frac{\sigma_x^2}{\sigma_e^2} \\ &= 10\log_{10} \frac{\sigma_x^2 F_s}{2BP_d} \\ &= 10\log_{10} \frac{\sigma_x^2 F_s}{2BP_d} + 10\log_{10} F_s \end{aligned}$$

Thus, SQNR will increase by 3dB if F_s is doubled.

(b) The most efficient way to double the sampling frequency is to use a sigma-delta modulator.

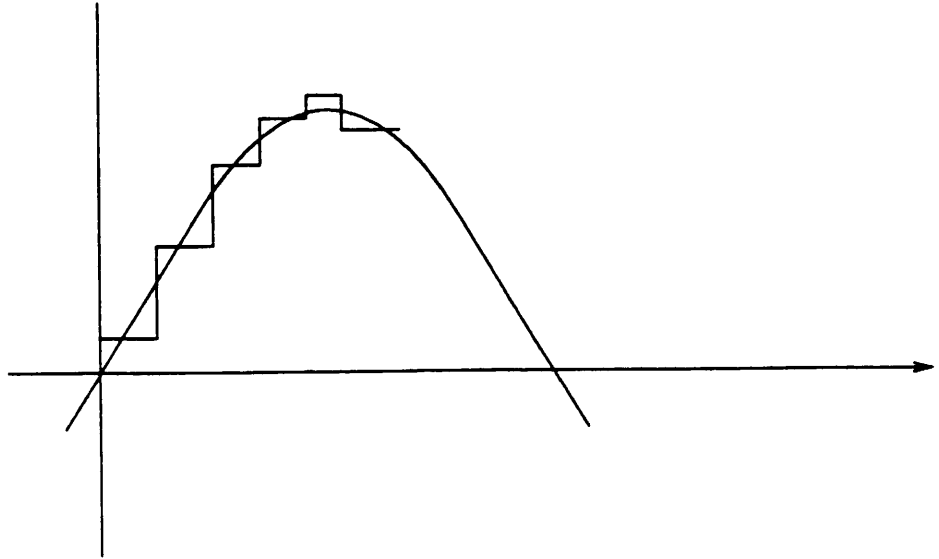

Figure 9.2:

9.10

(a)

$$\begin{aligned}
 S_e(F) &= \frac{\sigma_e^2}{F_s} \\
 |H_n(F)| &= 2 \left| \sin \frac{\pi F}{F_s} \right| \\
 \sigma_n^2 &= \int_{-B}^B |H_n(F)|^2 S_e(F) dF \\
 &= 2 \int_0^B 4 \sin^2 \left(\frac{\pi F}{F_s} \right) \frac{\sigma_e^2}{F_s} dF \\
 &= \frac{4\sigma_e^2}{F_s} \int_0^B \left(1 - \cos \frac{2\pi F}{F_s} \right) dF \\
 &= \frac{4\sigma_e^2}{F_s} \left[B - \frac{F_s}{2\pi} \sin \frac{2\pi B}{F_s} \right] \\
 &= \frac{2\sigma_e^2}{\pi} \left[\frac{2\pi B}{F_s} - \sin \frac{2\pi B}{F_s} \right]
 \end{aligned}$$

(b)

$$\begin{aligned}
 \text{For } \frac{2\pi B}{F_s} &\ll 1, \\
 \sin \frac{2\pi B}{F_s} &\approx \frac{2\pi B}{F_s} - \frac{1}{6} \left(\frac{2\pi B}{F_s} \right)^3
 \end{aligned}$$

$$\begin{aligned} \text{Therefore, } \sigma_n^2 &= \frac{2\sigma_e^2}{\pi} \left[\frac{2\pi B}{F_s} - \frac{2\pi B}{F_s} - \frac{1}{6} \left(\frac{2\pi B}{F_s} \right)^3 \right] \\ &= \frac{1}{3} \pi^2 \sigma_e^2 \left(\frac{2B}{F_s} \right)^3 \end{aligned}$$

9.11

(a)

$$\begin{aligned} \{[X(z) - D_q(z)] \frac{1}{1-z^{-1}} - D_q(z)\} \frac{z^{-1}}{1-z^{-1}} &= D_q(z) - E(z) \\ D_q(z) &= z^{-1} X(z) + (1-z^{-1})^2 E(z) \\ \text{Therefore, } H_s(z) &= z^{-1} \\ \text{and } H_n(z) &= (1-z^{-1})^2 \end{aligned}$$

(b)

$$\begin{aligned} |H_n(F)| &= 4 \sin^2 \left(\frac{\pi F}{F_s} \right) \\ &= 2 \left(1 - \cos \left(\frac{2\pi F}{F_s} \right) \right) \end{aligned}$$

(c)

$$\begin{aligned} \sigma_n^2 &= \int_{-B}^B |H_n(F)|^2 \frac{\sigma_e^2}{F_s} dF \\ &\approx 2 \int_0^B \left[4 \left(\frac{\pi F}{F_s} \right)^2 \right]^2 \frac{\sigma_e^2}{F_s} dF \\ &= \frac{32\pi^4 \sigma_e^2}{F_s^5} \int_0^B F^4 dF \\ &= \frac{1}{5} \pi^4 \sigma_e^2 \left(\frac{2B}{F_s} \right)^5 \end{aligned}$$

9.12

(a)

$$\begin{aligned} x(n) &= \cos \frac{2\pi}{N} n \\ x_a(t) &= x(n) \Big|_{n=\frac{t}{T}} \\ &= \cos \frac{2\pi t}{NT} \\ &= \cos 2\pi \left(\frac{F_s}{N} \right) t \\ \text{Therefore, } F_0 &= \frac{F_s}{N} \end{aligned}$$

(b) N analog sinusoids can be generated. There are N possible different starting phases.

9.13

(a)

$$\begin{aligned}
 h(t) &= \int_{-\infty}^{\infty} H(F)e^{j2\pi Ft} dF \\
 &= \int_{-\infty}^{\infty} [c(F - F_c) + c^*(-F - F_c)]e^{j2\pi Ft} dF \\
 &= c(t)e^{j2\pi F_c t} + c^*(t)e^{-j2\pi F_c t} \\
 &= 2\text{Re}[c(t)e^{j2\pi F_c t}]
 \end{aligned}$$

(b)

$$\begin{aligned}
 H(F) &= C(F - F_c) + C^*(-F - F_c) \\
 X(F) &= \frac{1}{2}[U(F - F_c) + U^*(-F - F_c)] \\
 Y(F) &= X(F)H(F) \\
 &= \frac{1}{2}[C(F - F_c)U(F - F_c) + U^*(-F - F_c)C^*(-F - F_c)] \\
 &\quad + \frac{1}{2}[C(F - F_c)U^*(-F - F_c) + U(F - F_c)C^*(-F - F_c)]
 \end{aligned}$$

$$\text{But } C(F - F_c)U^*(-F - F_c) = U(F - F_c)C^*(-F - F_c) = 0$$

$$\mathcal{F}^{-1}[C(F)U(F)] = \int_{-\infty}^{\infty} c(\tau)u(t - \tau)d\tau \equiv v(t)$$

$$\begin{aligned}
 \text{Hence, } y(t) &= \frac{1}{2}v(t)e^{j2\pi F_c t} + \frac{1}{2}v^*(t)e^{-j2\pi F_c t} \\
 &= \text{Re}[v(t)e^{j2\pi F_c t}]
 \end{aligned}$$

9.14

(a) Refer to fig 9.3.

(b) Refer to fig 9.4.

(c) Refer to fig 9.5. The first order hold interpolator performs better than the zero order interpolator because the frequency response of the first order hold is more closer to the ideal interpolator than that of the zero order hold case.

(d) Refer to fig 9.6.

(e) Refer to fig 9.7. Higher order interpolators with more memory or cubic spline interpolators would be a better choice.

9.15

(a) $x_p(t) = \sum_{n=-\infty}^{\infty} x_a(t - nT_s)$ is a periodic signal with period T_s . The fourier coefficients in a fourier series representation are

$$\begin{aligned}
 c_k &= \frac{1}{T_s} \int_{-\frac{T_s}{2}}^{\frac{T_s}{2}} x_p(t)e^{-j\frac{2\pi kt}{T_s}} dt \\
 &= \frac{1}{T_s} \int_{-\frac{T_s}{2}}^{\frac{T_s}{2}} \sum_{n=-\infty}^{\infty} x_a(t - nT_s)e^{-j\frac{2\pi kt}{T_s}} dt \\
 &= \frac{1}{T_s} \sum_{n=-\infty}^{\infty} \int_{-\frac{T_s}{2}}^{\frac{T_s}{2}} x_a(t - nT_s)e^{-j\frac{2\pi kt}{T_s}} dt
 \end{aligned}$$

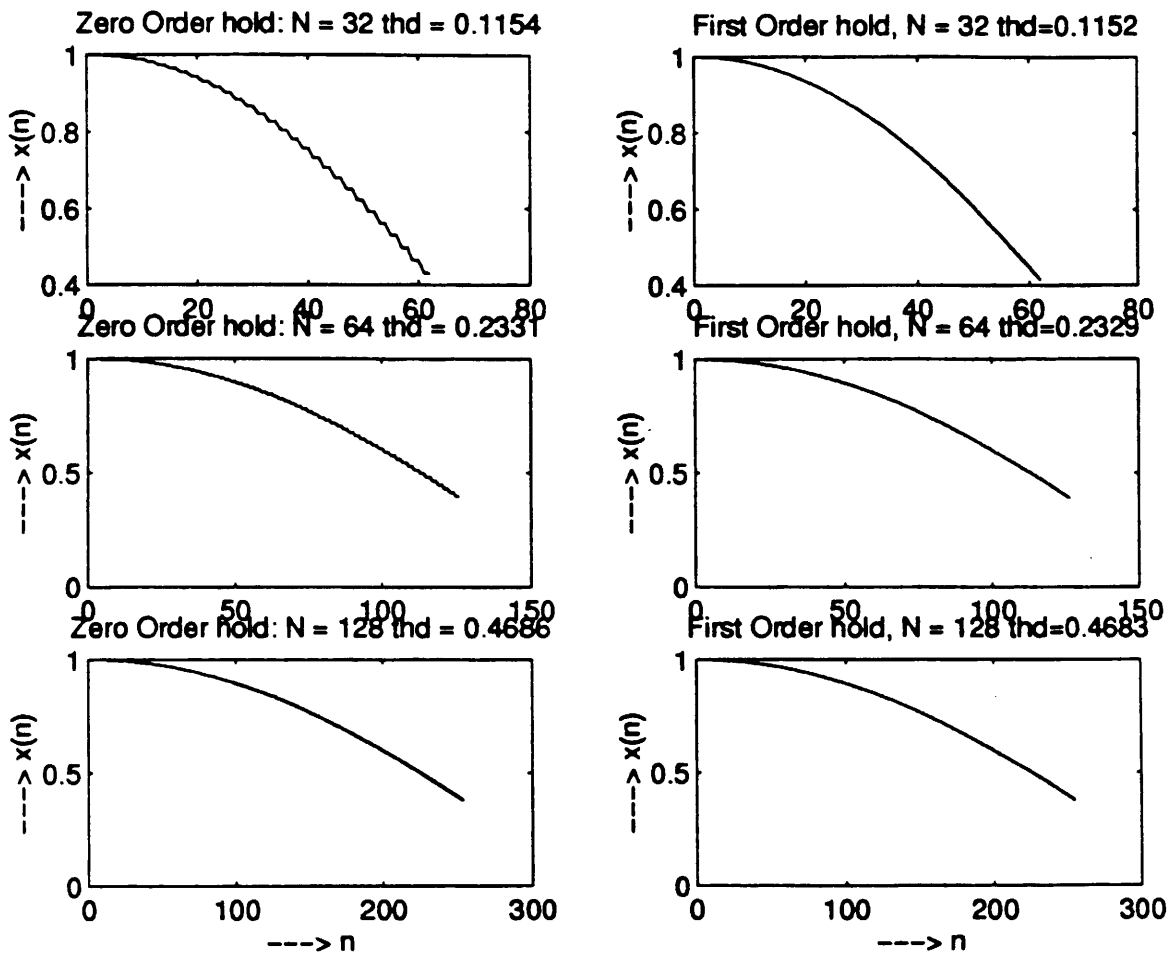

Figure 9.3:

$$\begin{aligned}
 &= \frac{1}{T_s} \sum_{n=-\infty}^{\infty} \int_{nT_s - \frac{T_s}{2}}^{nT_s + \frac{T_s}{2}} x_a(t') e^{-j2\pi k(t' + nT_s)} dt' \\
 &= \frac{1}{T_s} \int_{-\infty}^{\infty} x_a(t') e^{-j2\pi kt'} dt' \\
 &= \frac{1}{T_s} X_a\left(\frac{k}{T_s}\right) \\
 &= \frac{1}{T_s} X_a(k\delta F)
 \end{aligned}$$

(b) Let

$$w(t) = \begin{cases} 1, & -\frac{T_s}{2} \leq t \leq \frac{T_s}{2} \\ 0, & \text{otherwise} \end{cases}$$

$$\text{If } T_s \geq 2\tau, \quad x_a(t) = x_p(t)w(t)$$

$$X_a(F) = X_p(F) * W(F)$$

$$X_a(F) = \left[\sum_{k=-\infty}^{\infty} c_k \delta\left(F - \frac{k}{T_s}\right) \right] * \left[T_s \frac{\sin \pi F T_s}{\pi F T_s} \right]$$

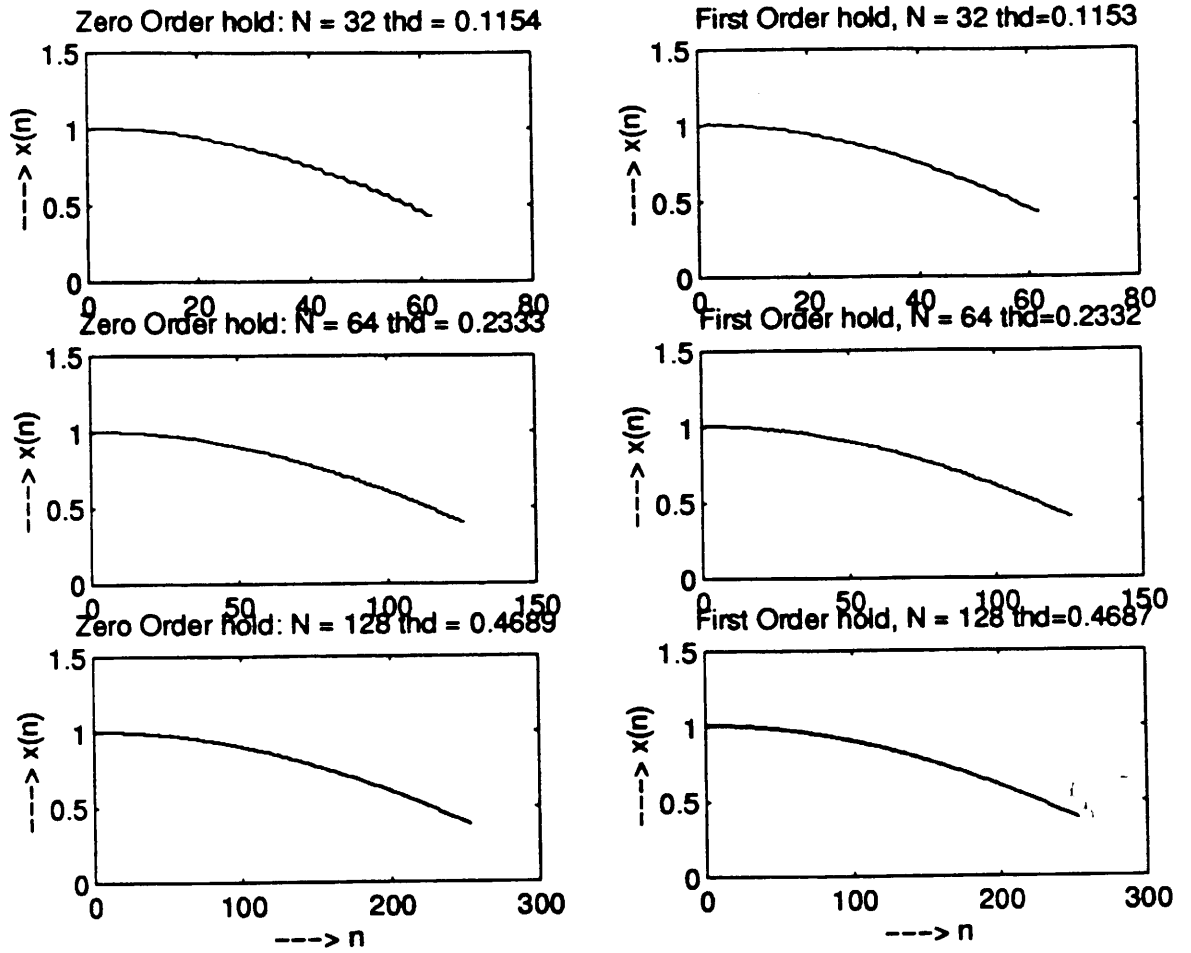

Figure 9.4:

$$\begin{aligned}
 &= T_s \sum_{k=-\infty}^{\infty} c_k \frac{\sin \pi (F - \frac{k}{T_s}) T_s}{\pi (F - \frac{k}{T_s}) T_s} \\
 &= \sum_{k=-\infty}^{\infty} X_a(k \delta F) \frac{\sin \pi (F - \frac{k}{T_s}) T_s}{\pi (F - \frac{k}{T_s}) T_s}, \quad T_s = \frac{1}{\delta F}
 \end{aligned}$$

(c) If $T < 2\tau$, there will be aliasing in every period of $x_p(t)$. Hence, $x_a(t) \neq x_p(t)w(t)$ and consequently, $x_a(t)$ cannot be recovered from $x_p(t)$.

(d) From (b) $X_a(F) = \sum_{k=-\infty}^{\infty} X_a(k \delta F) \frac{\sin \pi \frac{(F - k \delta F) T_s}{\delta F}}{\pi \frac{(F - k \delta F) T_s}{\delta F}}$

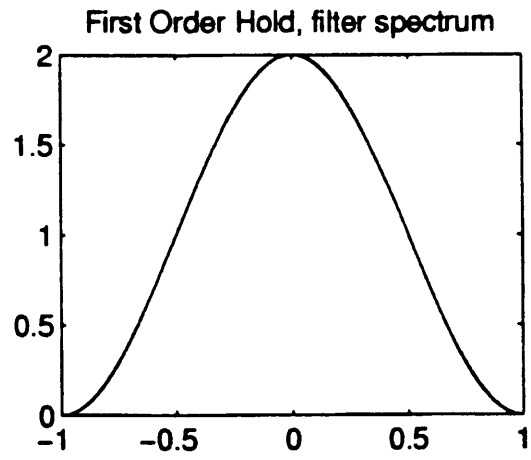
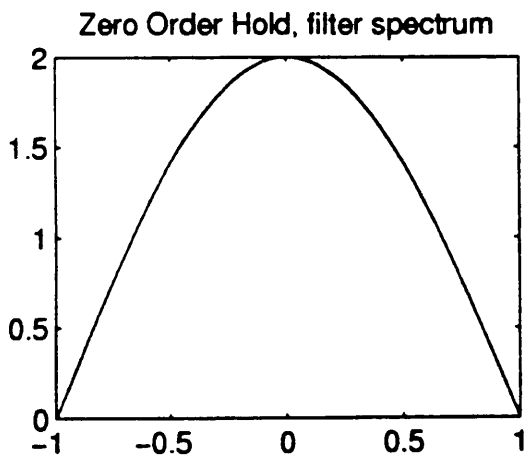
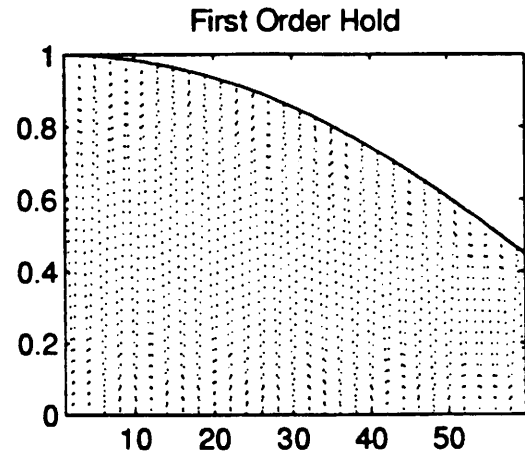
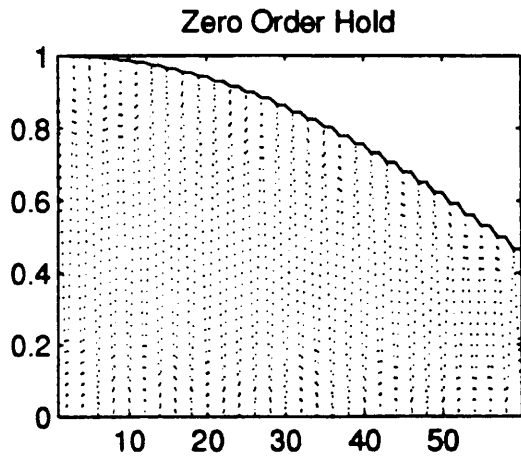

Figure 9.5:

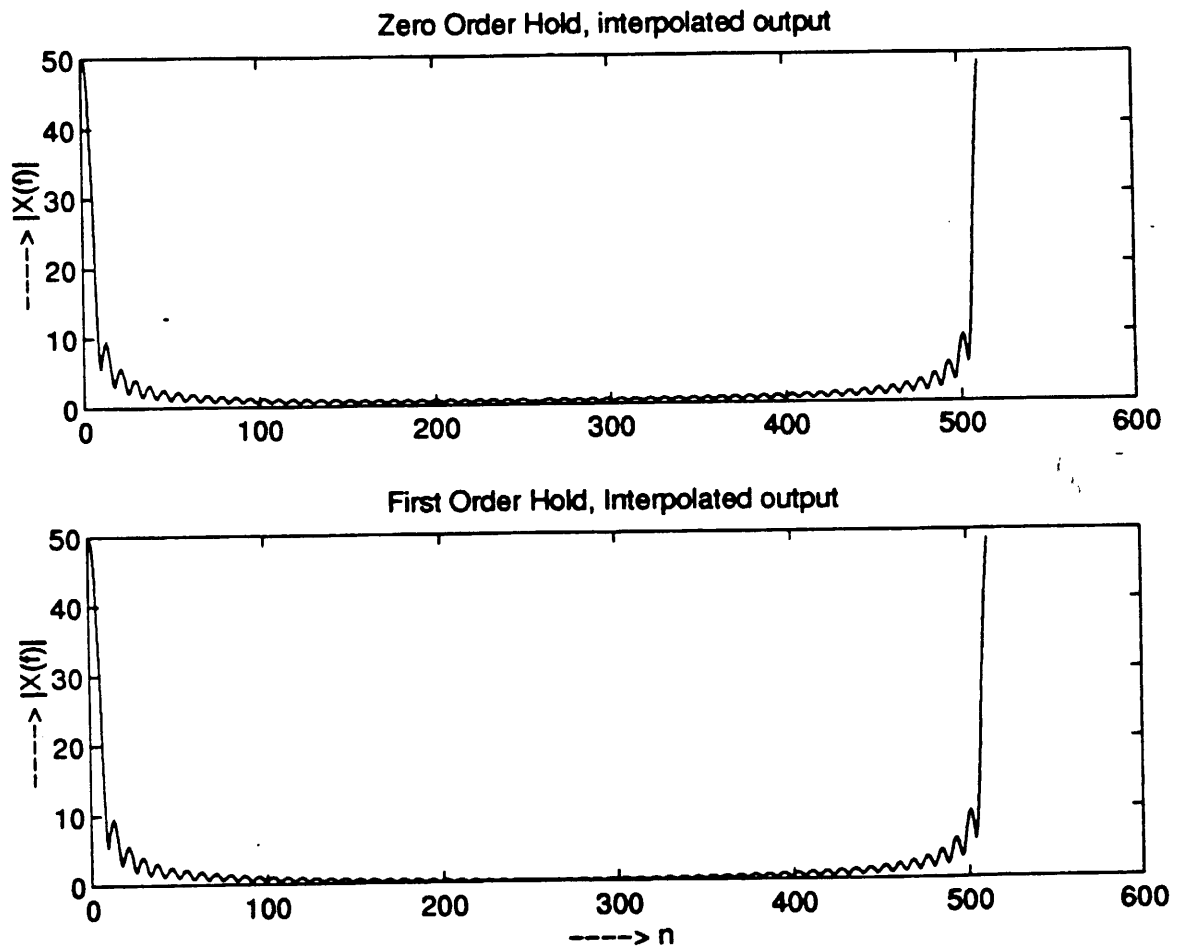

Figure 9.6:

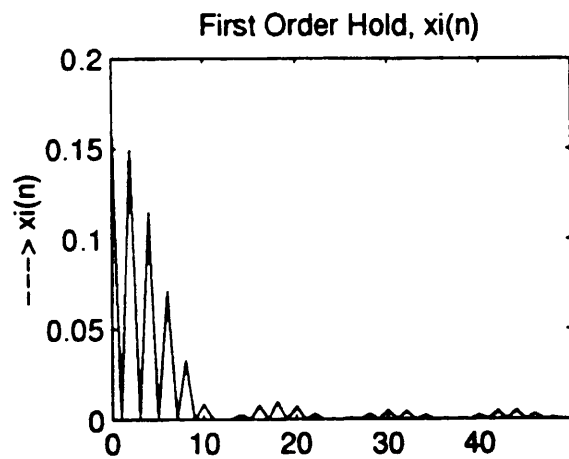
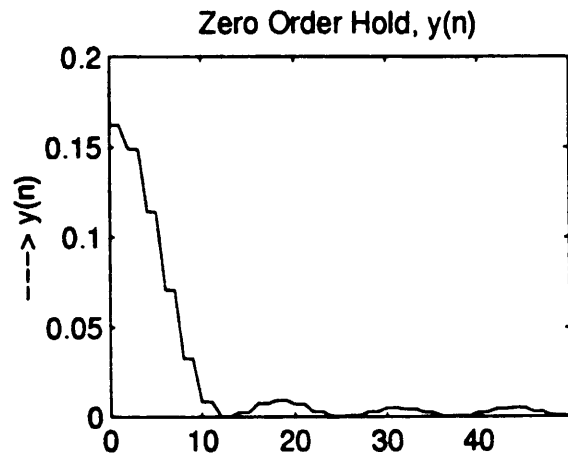
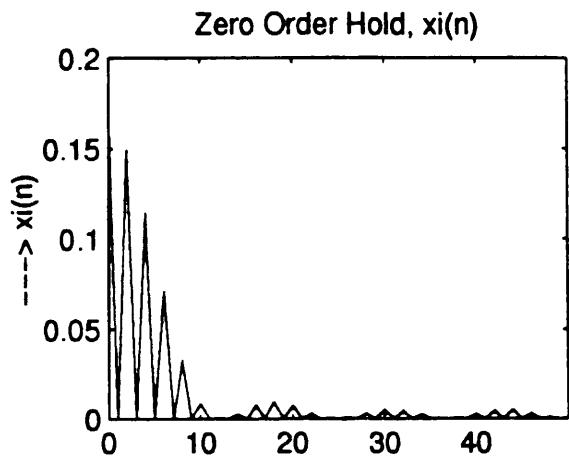

Figure 9.7:

Chapter 10

10.1

(a) Let the corresponding baseband spectrum be called $X_b(\Omega)$. Then

$$X_a(\Omega) = \frac{1}{2}[X_b(\Omega - 2000\pi) + X_b(\Omega + 2000\pi)]$$

With frequencies normalized to F_x ,

$$w' = \frac{\Omega}{F_x}$$

The sequence $x(n)$ has DTFT

$$\begin{aligned} X(w') &= \sum_{q=-\infty}^{\infty} X_a(w' - 2\pi q) \\ &= \sum_{q=-\infty}^{\infty} [X_a(w' - 0.8\pi - 2\pi q) + X_b(w' + 0.8\pi - 2\pi q)] \end{aligned}$$

modulation by $\cos(0.8\pi)$ causes shifts up and down by 0.8π (and scaling by $\frac{1}{2}$) of each component in the spectrum. Refer to fig 10.1. Ideal LPF preserves only the baseband spectrum (of each period). Refer to fig 10.2 The downsampling produces the figure in fig 10.3, where $w'' = \frac{\Omega}{F_y} = \frac{\Omega D}{F_x} = 10w'$. Note that there is no aliasing in the spectrum $|Y(w'')|$ because the decimated sample rate, in terms of w' , is $\frac{2\pi}{10} > 0.04\pi$.

(b) The assumed spectral amplitude normalization in fig 10.1 implies that the analog FT (magnitude spectrum) of $x_a(t)$ is (refer to fig 10.4). The given sample rate is identical to F_y above, $F_y = 250\text{Hz}$. The DTFT of samples taken at this rate is $\tilde{Y}(\Omega) = \frac{1}{T_y} \sum_q X_a(\Omega - q\Omega_y)$ where $\Omega_y = 2\pi F_y$. On a scaled frequency axis $w'' = \Omega T_y = \frac{\Omega}{F_y}$, $\tilde{Y}(w'') = \frac{1}{T_y} \sum_q X_a(w'' - q2\pi)$. Consequently $\tilde{y}(n) = y(n)$.

10.2

(a) $X(w) = \frac{1}{(1 - ae^{-jw})}$

(b) After decimation $Y(w') = \frac{1}{2}X(\frac{w'}{2}) = \frac{1}{2(1 - ae^{-j\frac{w'}{2}})}$

(c)

$$\begin{aligned} \text{DTFT } \{x(2n)\} &= \sum_n x(2n)e^{-jw2n} \\ &= \sum_n x(2n)e^{-jw'n} \\ &= Y(w') \end{aligned}$$

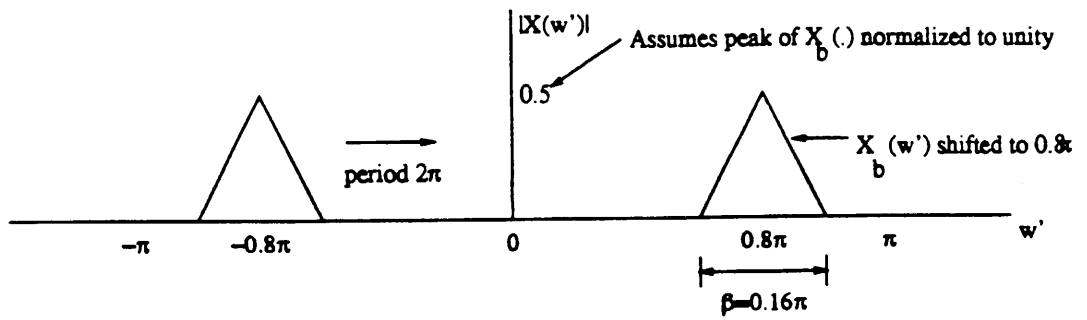

Figure 10.1:

10.3

(a) Refer to fig 10.5

(b)

$$\begin{aligned}
 \text{Let } w' &= \frac{\Omega}{F_x}, \quad w'' = \frac{\Omega}{F_y} = \frac{w'}{2} \\
 Y(w'') &= \sum_{n \text{ even}} x\left(\frac{n}{2}\right) e^{-jw''n} + \sum_{n \text{ odd}} \frac{1}{2} \left[x\left(\frac{n-1}{2}\right) + x\left(\frac{n+1}{2}\right) \right] e^{-jw''n} \\
 &= \sum_p x(p) e^{-jw''2p} + \frac{1}{2} \sum_q [x(q) + x(q+1)] e^{-jw''(2q+1)} \\
 &= X(2w'') + \frac{1}{2} e^{-jw''} [X(2w'') + e^{j2w''} X(2w'')] \\
 &= X(2w'') [1 + \cos w'']
 \end{aligned}$$

$$X(w') = \begin{cases} 1, & 0 \leq |w'| \leq 0.2\pi \\ 0, & \text{otherwise} \end{cases}$$

$$X(2w'') = \begin{cases} 1, & 0 \leq |2w''| \leq 0.2\pi \\ 0, & \text{otherwise} \end{cases}$$

$$= \begin{cases} 1, & 0 \leq |w''| \leq 0.1\pi \\ 0, & \text{otherwise} \end{cases}$$

$$Y(w'') = \begin{cases} 1 + \cos w'', & 0 \leq |w''| \leq 0.1\pi \\ 0, & \text{otherwise} \end{cases}$$

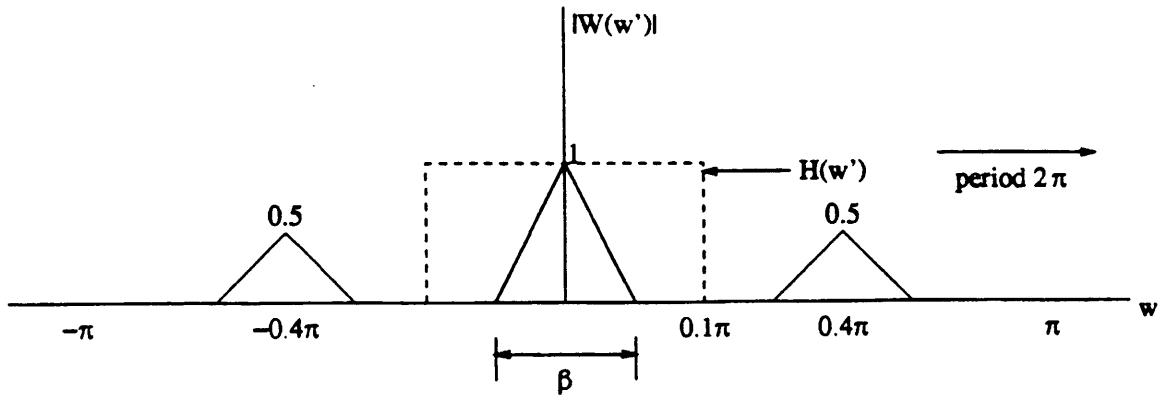

Figure 10.2:

(c) Refer to fig 10.6

$$Y(w'') = \begin{cases} 1 + \cos w'', & 0.35\pi \leq |w''| \leq 0.45\pi \\ & \text{or } 0.55\pi \leq |w''| \leq 0.65\pi \\ 0, & \text{otherwise} \end{cases}$$

10.4

(a) Let $w' = \frac{\Omega}{F_x}$, $w'' = \frac{\Omega D}{F_x}$. Refer to fig 10.7
Let $x''(n)$ be the downsampled sequence.

$$\begin{aligned} x''(n) &= x(nD) \\ X''(w'') &= \frac{1}{D} X\left(\frac{w''}{D}\right) \end{aligned}$$

As long as $Dw'_m \leq \pi$, $X(w')$ [hence $x(n)$] can be recovered from $X''(w'')$ [$x''(n) = x(Dn)$] using interpolation by a factor D :

$$X(w') = DX''(Dw')$$

The given sampling frequency is $w'_s = \frac{2\pi}{D}$. The condition $Dw'_m \leq \pi \rightarrow 2w'_m \leq \frac{2\pi}{D} = w'_s$
(b) Let $x_a(t)$ be the real analog signal from which samples $x(n)$ were taken at rate F_x . There exists a signal, say $x'_a(t')$, such that $x'_a(t') = X_a(\frac{t'}{T_x})$. $x(n)$ may be considered to be the samples of $x'(t')$ taken at rate $f_x = 1$. Likewise $x''(n) = x(nD)$ are samples of $x'(t')$ taken at rate $f'_x = \frac{1}{D} = \frac{1}{D}$. From sampling theory, we know that $x'(t')$ can be reconstructed from its samples $x''(n)$ as long as it is bandlimited to $f_m \leq \frac{1}{2D}$, or $w_m \leq \frac{\pi}{D}$, which is the case here. The reconstruction formula is

$$x'(t') = \sum_k x''(k) h_r(t' - kD)$$

where

$$h_r(t') = \frac{\sin(\frac{\pi}{D}t')}{(\frac{\pi}{D}t')}$$

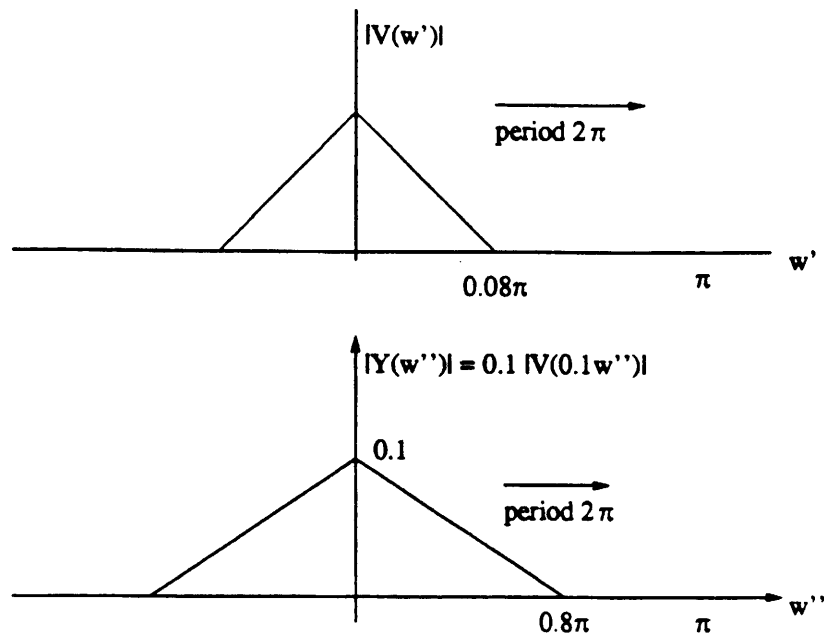

Figure 10.3:

Refer to fig 10.8

Actually the bandwidth of the reconstruction filter may be made as small as w'_m , or as large as $\frac{2\pi}{D} - w'_m$, so h_r may be

$$h_r(t') = \frac{\sin(w'_c t')}{(w'_c t')}$$

where $w'_m \leq w'_c \leq \frac{2\pi}{D} - w'_m$. In particular $x(n) = x'(t' = n)$ so

$$x(n) = \sum_k x(kD) h_r(n - kD)$$

(c) Clearly if we define

$$v(p) = \begin{cases} x(p), & \text{if } p \text{ is an integer multiple of } D \\ 0, & \text{other } p \end{cases}$$

then, we may write 10.4 as

$$x(n) = \sum_p v(p) h_r(n - p)$$

so $x(n)$ is reconstructed as (see fig 10.9)

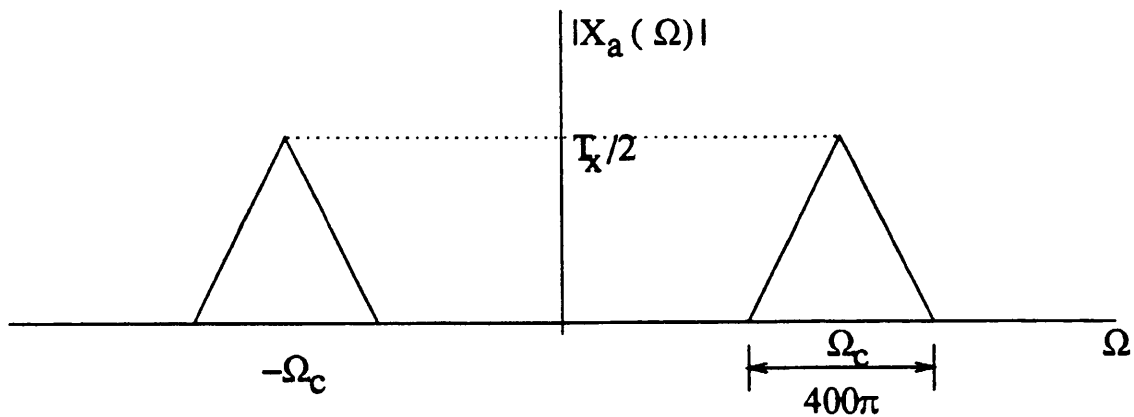

Figure 10.4:

10.5

(a)

$$\begin{aligned}
 \text{Let } w &= \frac{\Omega}{F_x}, & w'' &= \frac{2\Omega}{F_x} \\
 X_s(w) &= \sum_n x_s(n) e^{-jw n} \\
 &= \sum_m x(2m) e^{-jw 2m} \\
 &= \frac{1}{2} \sum_q X(w - \frac{2\pi}{2} q) \\
 &= \frac{1}{2} \sum_q X(w - \pi q)
 \end{aligned}$$

To recover $x(n)$ from $x_s(n)$: see fig 10.10

(b)

$$\begin{aligned}
 \text{Recall } w' &= 2w \\
 X_d(w') &= \sum_n x_d(n) e^{-jw' n} \\
 &= \sum_{n \text{ even}} x_s(n) e^{-jw' \frac{n}{2}} \\
 &= \sum_n x_s(n) e^{-jw' \frac{n}{2}}
 \end{aligned}$$

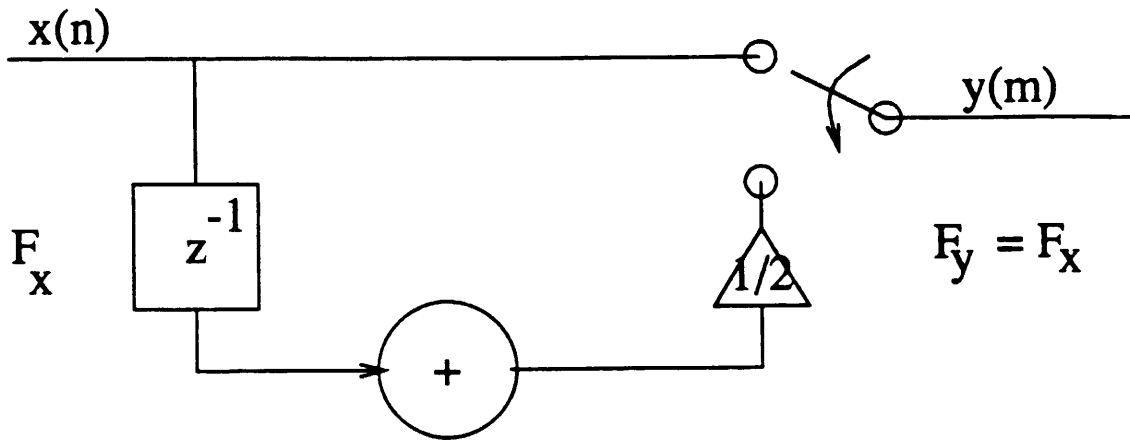

Figure 10.5:

since $x_s(n) = 0$ when n odd

$$= X_s\left(\frac{\omega'}{2}\right)$$

see fig 10.11

No information is lost since the decimated sample rate still exceeds twice the bandlimit of the original signal.

10.6

A filter of length 30 meets the specification. The cutoff frequency is $\omega_c = \frac{\pi}{5}$ and the coefficients are given below:

$$\begin{aligned} h(1) &= h(30) = 0.006399 \\ h(2) &= h(29) = -0.01476 \\ h(3) &= h(28) = -0.001089 \\ h(4) &= h(27) = -0.002871 \\ h(5) &= h(26) = 0.01049 \\ h(6) &= h(25) = 0.02148 \\ h(7) &= h(24) = 0.01948 \\ h(8) &= h(23) = -0.0003107 \\ h(9) &= h(22) = -0.03005 \\ h(10) &= h(21) = -0.04988 \end{aligned}$$

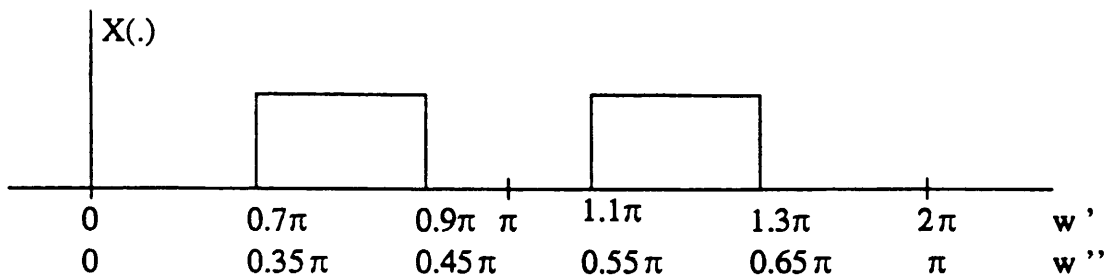

Figure 10.6:

$$\begin{aligned}
 h(11) &= h(20) = -0.03737 \\
 h(12) &= h(19) = 0.01848 \\
 h(13) &= h(18) = 0.1075 \\
 h(14) &= h(17) = 0.1995 \\
 h(15) &= h(16) = 0.2579 \\
 p_k(n) &= h(n+k), \quad k = 0, 1, \dots
 \end{aligned}$$

corresponding polyphase filter structure (see fig 10.12)

10.7

A filter of length 30 meets the specification. The cutoff frequency is $\omega_c = \frac{\pi}{2}$ and the coefficients are given below:

$$\begin{aligned}
 h(1) &= h(30) = 0.006026 \\
 h(2) &= h(29) = -0.01282 \\
 h(3) &= h(28) = -0.002858 \\
 h(4) &= h(27) = 0.01366 \\
 h(5) &= h(26) = -0.004669 \\
 h(6) &= h(25) = -0.01970 \\
 h(7) &= h(24) = 0.01598 \\
 h(8) &= h(23) = 0.02138 \\
 h(9) &= h(22) = -0.03498 \\
 h(10) &= h(21) = -0.01562 \\
 h(11) &= h(20) = 0.06401 \\
 h(12) &= h(19) = -0.007345
 \end{aligned}$$

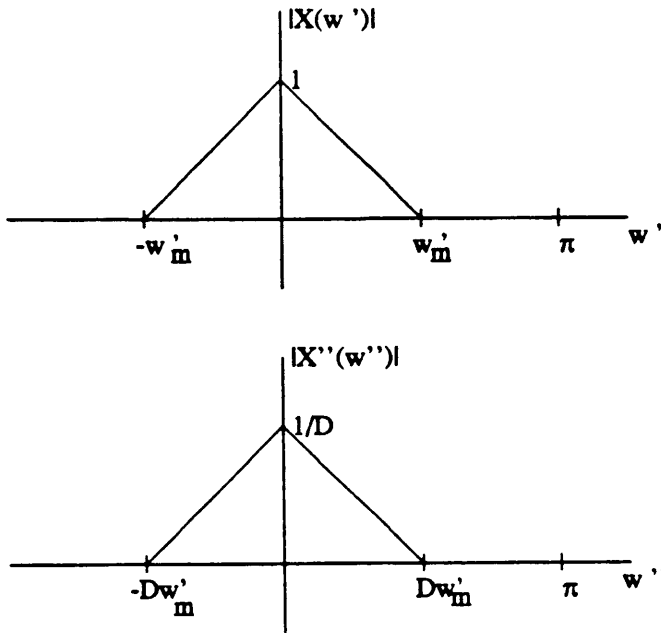

Figure 10.7:

$$\begin{aligned}
 h(13) &= h(18) = -0.1187 \\
 h(14) &= h(17) = 0.09805 \\
 h(15) &= h(16) = 0.4923 \\
 p_k(n) &= h(2n + k), \quad k = 0, 1; \quad n = 0, 1, \dots, 14
 \end{aligned}$$

corresponding polyphase filter structure (see fig 10.13)

10.8

The FIR filter that meets the specifications of this problem is exactly the same as that in prob10.6. Its bandwidth is $\frac{\pi}{5}$. Its coefficients are

$$\begin{aligned}
 g(n, m) &= h(nI + (mD)_I) \\
 &= h(nI + mD - [\frac{mD}{I}]I) \\
 &= h(2n + 5m - 2[\frac{5m}{2}]) \\
 g(0, m) &= \{h(0), h(1)\} \\
 g(1, m) &= \{h(2), h(3)\} \\
 &\vdots \\
 g(14, m) &= \{h(28), h(29)\}
 \end{aligned}$$

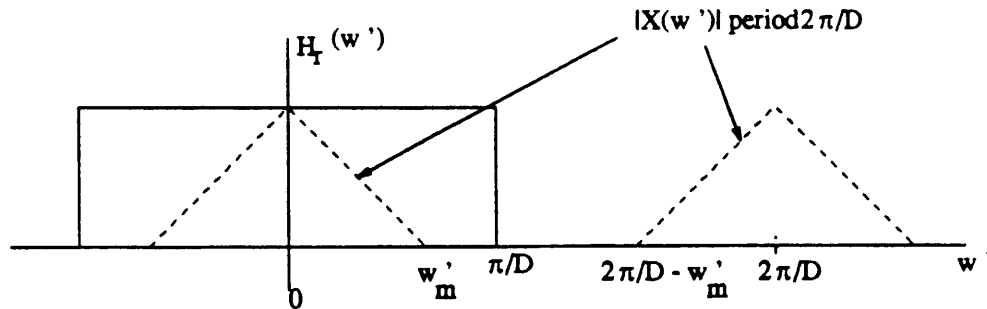

Figure 10.8:

A polyphase filter would employ two subfilters, each of length 15

$$p_0(n) = \{h(0), h(2), \dots, h(28)\}$$

$$p_1(n) = \{h(1), h(3), \dots, h(29)\}$$

10.9

(a)

$$x(n) = \{x_0, x_1, x_2, \dots\}$$

$D = I = 2$. Decimation first

$$z_2(n) = \{x_0, x_2, x_4, \dots\}$$

$$y_2(n) = \{x_0, 0, x_2, 0, x_4, 0, \dots\}$$

Interpolation first

$$z_1(n) = \{x_0, 0, x_1, 0, x_2, 0, \dots\}$$

$$y_1(n) = \{x_0, x_1, x_2, \dots\}$$

$$\text{so } y_2(n) \neq y_1(n)$$

(b) suppose $D = dk$ and $I = ik$ and d, i are relatively prime.

$$x(n) = \{x_0, x_1, x_2, \dots\}$$

Decimation first

$$z_2(n) = \{x_0, x_{dk}, x_{2dk}, \dots\}$$

$$y_2(n) = \left\{ x_0, \underbrace{0, \dots, 0}_{i k - 1}, x_{dk}, \underbrace{0, \dots, 0}_{i k - 1}, x_{2dk}, \dots \right\}$$

Interpolation first

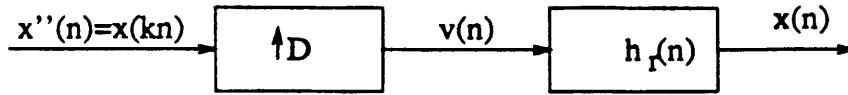

Figure 10.9:

$$z_1(n) = \left\{ \underbrace{x_0, 0, \dots, 0}_{ik-1}, \underbrace{x_1, 0, \dots, 0}_{ik-1}, \underbrace{x_2, 0, \dots, 0}_{ik-1}, \dots \right\}$$

$$y_1(n) = \left\{ \underbrace{x_0, 0, \dots, 0}_{d-1}, \underbrace{x_d, 0, \dots, 0}_{d-1}, \dots \right\}$$

Thus $y_2(n) = y_1(n)$ iff $d = dk$ or $k = 1$ which means that D and I are relatively prime.

10.10

(a) Refer to fig 10.14

$$\begin{aligned} y_1(n) &= h(n) * w_1(n) \\ &= h(n) * x(nD) \\ &= \sum_{k=0}^{\infty} h(k)x[(n-k)D] \\ H(z^D) &= \dots h(0)z^0 + h(1)z^D + h(2)z^{2D} + \dots \\ H(z^D) &\leftrightarrow \tilde{h}(n) \end{aligned}$$

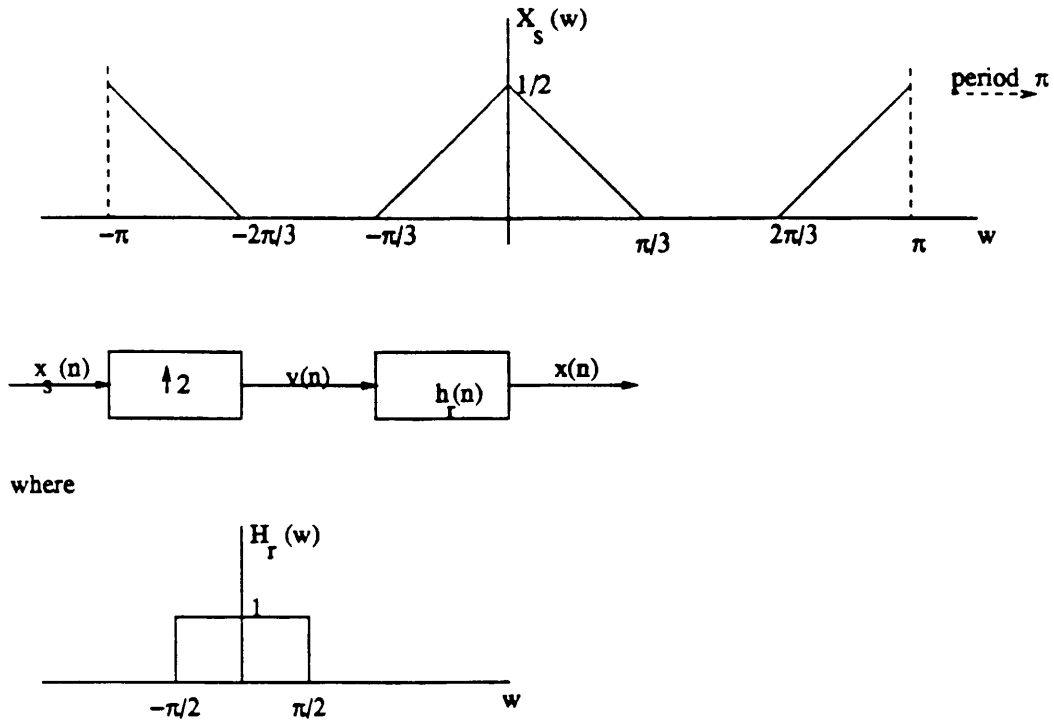

Figure 10.10:

$$\begin{aligned}
 &= \left\{ h_0, \underbrace{0, \dots, 0}_{D-1}, H_1, \underbrace{0, \dots, 0}_{D-1}, h(2), \dots \right\} \\
 \text{so } w_2(n) &= \sum_{k=0}^{nD-1} \tilde{h}(k)x(n-k) \\
 &= \sum_{k=0}^n \tilde{h}(kD)x(n-kD) \\
 &= \sum_{k=0}^n h(k)x(n-kD) \\
 y_2(n) &= w_2(nD) \\
 &= \sum_{k=0}^n h(k)x(nD-kD) \\
 &= \sum_{k=0}^n h(k)x[(n-k)D] \\
 \text{So } y_1(n) &= y_2(n)
 \end{aligned}$$

(b)

$$\begin{aligned}
 w_1(n) &= \sum_{k=0}^{\infty} h(k)x(n-k) \\
 y_1(n) &= w_1(p), \quad n = pI \text{ (} p \text{ an integer)}
 \end{aligned}$$

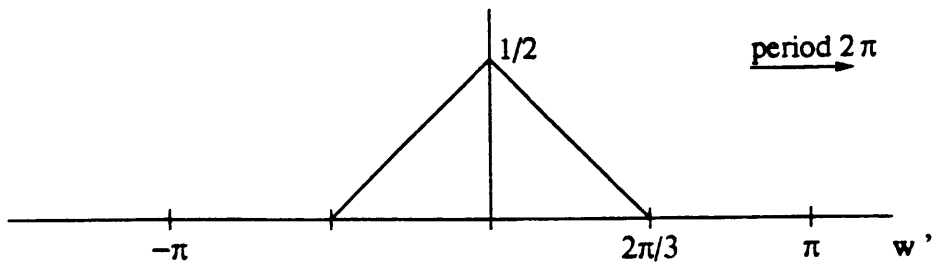

Figure 10.11:

$$\begin{aligned}
 &= 0, \quad \text{other } n \\
 w_2(n) &= x(p), \quad n = pI \\
 &= 0, \quad \text{other } n
 \end{aligned}$$

Let $\tilde{h}(n)$ be the IR corresponding to $H(z^I)$

$$\begin{aligned}
 y_2(n) &= \sum_{k=0}^{\infty} \tilde{h}(k) w_2(n-k) \\
 &= \sum_{k=0}^{\infty} \tilde{h}(kI) w_2(n-kI) \\
 &= \sum_{k=0}^{\infty} h(k) w_2(n-kI) \\
 \text{for } n &= pI \\
 y_2(n) &= \sum_{k=0}^{\infty} h(k) w_2((p-k)I) \\
 &= \sum_{k=0}^{\infty} h(k) x(p-k) \\
 &= w_1(p) \text{ (see above)} \\
 \text{for } n &\neq pI \\
 y_2(n) &= \sum_{k=0}^{\infty} h(k) \cdot 0 = 0
 \end{aligned}$$

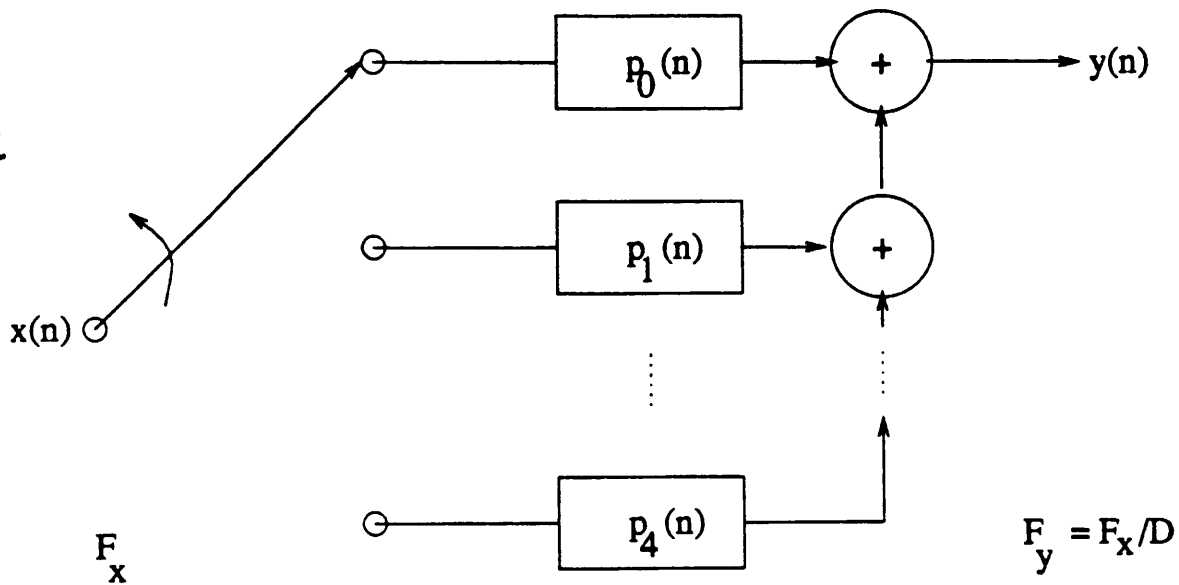

Figure 10.12:

so we conclude $y_1(n) = y_2(n)$

10.11

(a)

$$\begin{aligned}
 H(z) &= \sum_n h(2n)z^{-2n} + \sum_n h(2n+1)z^{-2n-1} \\
 &= \sum_n h(2n)(z^2)^{-n} + z^{-1} \sum_n h(2n+1)(z^2)^{-n} \\
 &= H_0(z^2) + z^{-1}H_1(z^2) \\
 \text{Therefore } H_0(z) &= \sum_n h(2n)z^{-n} \\
 H_1(z) &= \sum_n h(2n+1)z^{-n}
 \end{aligned}$$

(b)

$$\begin{aligned}
 H(z) &= \sum_n h(nD)z^{-nD} + \sum_n h(nD+1)z^{-nD-1} + \dots \\
 &\quad + \sum_n h(nD+D-1)z^{-nD-D+1} \\
 &= \sum_{k=0}^{D-1} z^{-k} \sum_n h(nD+k)(z^D)^{-n}
 \end{aligned}$$

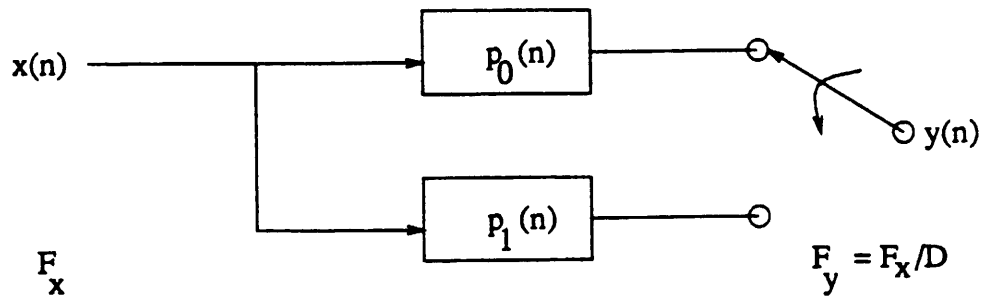

Figure 10.13:

$$\text{Therefore } H_k(z) = \sum_n h(nD + k)z^{-n}$$

(c)

$$\begin{aligned} H(z) &= \frac{1}{1 - az^{-1}} \\ &= \sum_{n=0}^{\infty} a^n z^{-n} \\ H_0(z) &= \sum_{n=0}^{\infty} a^{2n} z^{-n} \\ &= \frac{1}{1 - a^2 z^{-1}} \\ H_1(z) &= \sum_{n=0}^{\infty} a^{2n+1} z^{-n} \\ &= \frac{a}{1 - a^2 z^{-1}} \end{aligned}$$

10.12

$$\begin{aligned} D_1 &= 25, \quad D_2 = 4 \\ F_0 &= 10 \text{ kHz}, \quad F_1 = \frac{F_0}{D_1} = 400 \text{ Hz} \end{aligned}$$

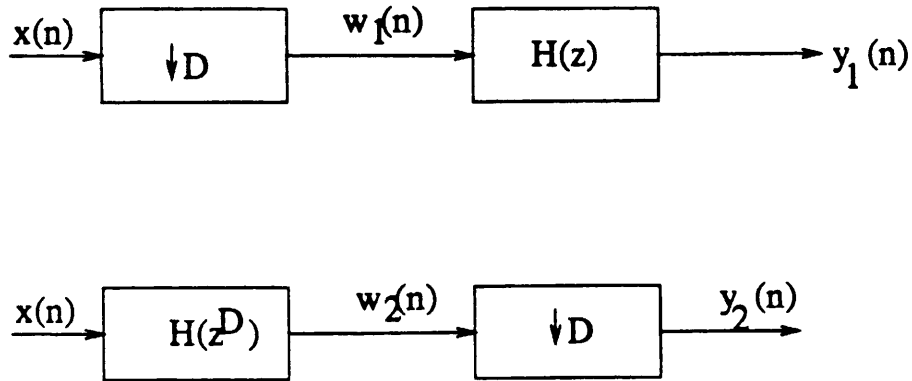

Figure 10.14:

Passband $0 \leq F \leq 50$
 Transition band $50 < F \leq 345$
 Stopband $345 < F \leq 5000$

$$F_2 = \frac{F_1}{D_2} = 100 \text{ Hz}$$

Passband $0 \leq F \leq 50$
 Transition band $50 < F \leq 55$
 Stopband $55 < F \leq 200$

$$\text{For filter 1, } \delta_1 = \frac{0.1}{2} = 0.05, \quad \delta_2 = 10^{-3}$$

$$\Delta f = \frac{345 - 50}{10,000} = 2.95 \times 10^{-2}$$

$$\hat{M}_1 = \frac{-10 \log \delta_1 \delta_2 - 13}{14.6 \Delta f} + 1 = 71$$

$$\text{For filter 2, } \delta_1 = 0.05, \quad \delta_2 = 10^{-3}$$

$$\Delta f = \frac{55 - 50}{400} = 7.5 \times 10^{-3}$$

$$\hat{M}_2 = \frac{-10 \log \delta_1 \delta_2 - 13}{14.6 \Delta f} + 1 \approx 275$$

The coefficients of the two filters can be obtained using a number of DSP software packages.

10.13

To avoid aliasing $F_s c \leq \frac{F_s}{2D}$. Thus $D = I = 50$.

Single stage

$$\begin{aligned}\delta_1 &= 0.1, & \delta_2 &= 10^{-3} \\ \Delta f &= \frac{65 - 60}{10,000} = 5 \times 10^{-4} \\ \hat{M}_1 &= \frac{-10 \log \delta_1 \delta_2 - 13}{14.6 \Delta f} + 1 \approx 3700\end{aligned}$$

Two stages

$$\begin{aligned}D_1 &= 25, & D_2 &= 2 & I_1 &= 2, & I_2 &= 25 \\ \text{stage 1: } F_1 &= \frac{10,000}{25} = 400\end{aligned}$$

Passband $0 \leq F \leq 60$

Transition band $60 < F \leq 335$

Stopband $335 < F \leq 5000$

$$\begin{aligned}\delta_1 &= 0.1, & \delta_2 &= \frac{10^{-3}}{4} \\ \Delta f &= 2.75 \times 10^{-2} & \hat{M}_1 &= 84 \\ \text{stage 2: } F_2 &= \frac{400}{2} = 200\end{aligned}$$

Passband $0 \leq F \leq 60$

Transition band $60 < F \leq 65$

Stopband $65 < F \leq 100$

$$\begin{aligned}\delta_1 &= 0.1, & \delta_2 &= \frac{10^{-3}}{4} \\ \Delta f &= 0.1875 & \hat{M}_2 &= 13\end{aligned}$$

Use DSP software to obtain filter coefficients.

10.14

$b_+(n)$ is nonzero for $0 \leq n \leq 2N - 2$ with N even. Let $c(n) = b_+[n - (N - 1)]$. So $c(n)$ is nonzero for $-(N - 1) \leq n \leq N - 1$. From (10.9.43)

$$\begin{aligned}B_+(w) + (-1)^{N-1} B_+(w - \pi) &= \alpha e^{-jw(N-1)} \\ \text{or } B_+(z) + (-1)^{N-1} B_+(-z) &= \alpha z^{-(N-1)} \\ \text{Therefore, } C(z)z^{-(N-1)} + (-1)^{N-1} C(-z)(-z)^{-(N-1)} &= \alpha z^{-(N-1)} \\ \text{or } C(z) + C(-z) &= \alpha \\ c(n) + c(-n) &= \alpha \delta(n) \\ \text{when } n \neq 0, c(n) &= -c(-n) \\ \text{when } n \text{ is odd } c(n) &= -c(-n) \\ \text{when } n \text{ is even but } n \neq 0, c(n) &= 0 \\ \text{(half-band filter)} \\ \text{when } n = 0, c(n) &= \frac{\alpha}{2}\end{aligned}$$

10.15

one stage:

$$\begin{aligned}\delta_1 &= 0.01, \quad \delta_2 = 10^{-3} \\ \Delta f &= \frac{100 - 90}{10,000} = 10^{-3}\end{aligned}$$

$$\dot{M} = \frac{-10 \log \delta_1 \delta_2 - 13}{14.6 \Delta f} + 1 \approx 2536$$

$$\begin{aligned}\text{two stages: } F_0 &= 2 \times 10^5 \text{ Hz} \\ I_1 &= 1, \quad I_2 = 2 \\ F_1 &= \frac{F_0}{I_1} = 2 \times 10^4 \text{ Hz}\end{aligned}$$

Passband $0 \leq F \leq 90$

Transition band $90 < F \leq 19,900$

$$\text{Therefore } \Delta f = \frac{19,900 - 90}{2 \times 10^5} = 0.09905$$

$$\text{and } \delta_{11} = \frac{\delta_1}{2}, \quad \delta_{12} = \delta_2$$

$$\dot{M}_1 = \frac{-10 \log \delta_1 \delta_2 - 13}{14.6 \Delta f} + 1 \approx 29$$

$$F_2 = \frac{F_1}{I_2} = 1 \times 10^4 \text{ Hz}$$

Passband $0 \leq F \leq 90$

Transition band $90 < F \leq 9,900$

$$\text{Therefore } \Delta f = \frac{9,900 - 90}{2 \times 10^4} = 0.4905$$

$$\text{and } \delta_{21} = \frac{\delta_1}{2}, \quad \delta_{22} = \delta_2$$

$$\dot{M}_2 = \frac{-10 \log \delta_1 \delta_2 - 13}{14.6 \Delta f} + 1 \approx 7$$

10.16

Suppose the output of the analysis section is $x_{a0}(m)$ and $x_{a1}(m)$. After interpolation by 2, they become $y_0(m)$ and $y_1(m)$. Thus

$$y_k(m) = \begin{cases} x_{ak}(\frac{m}{2}), & m \text{ even } k = 0, 1 \\ 0, & m \text{ odd} \end{cases}$$

The final output is

$$\begin{aligned}z(m) &= y_0(m) * 2h(m) + y_1(m) * [-2(-1)^m h(m)] \\ \text{when } m \text{ is even, say } m &= 2j, \\ z(m) = z(2j) &= 2y_0(m) * h(m) - 2y_1(m) * h(m) \\ &= 2 \sum_k y_0(k) h(m-k) - 2 \sum_k y_1(k) h(m-k) \\ &= 2 \sum_l y_0(2l) h(2j-2l) - 2 \sum_l y_1(2l) h(2j-2l)\end{aligned}$$

$$\begin{aligned}
&= 2 \sum_l x_{a0}(l)h[2(j-l)] - 2 \sum_l x_{a1}(l)h[2(j-l)] \\
&= 2[x_{a0}(j) - x_{a1}(j)] * h(2j) \\
&= 2[x_{a0}(j) - x_{a1}(j)] * p_0(j)
\end{aligned}$$

In the same manner, it can be shown that

$$z(2j+1) = 2[x_{a0}(j) + x_{a1}(j)] * p_1(j)$$

10.17

Refer to fig 10.15, where $h_i(n)$ is a lowpass filter with cutoff freq. $\frac{\pi}{T}$. After transposition (refer

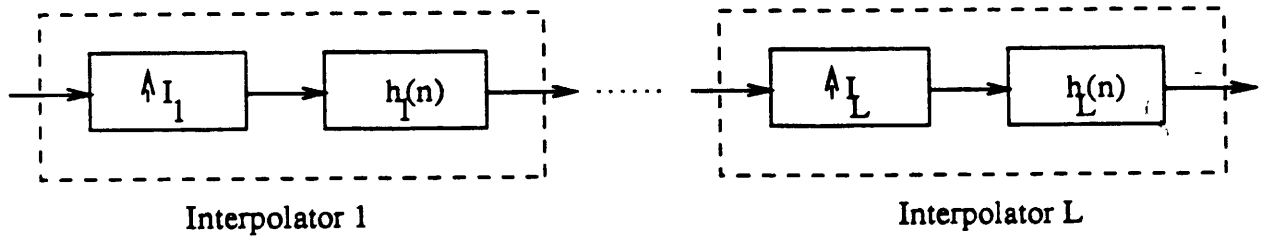

Figure 10.15: $I = I_1 I_2 \dots I_L$ L -stage interpolator

to fig 10.16). As $D = I$, let $D_i = I_{L+1-i}$, then $D = D_1 D_2 \dots D_L$. Refer to fig 10.17. Obviously, this is equivalent to the transposed form above.

10.18

Suppose that output is $y(n)$. Then $T_y = \frac{k}{T} T_x$. $F_y = \frac{1}{T_y} = \frac{1}{k} \frac{1}{T_x} = \frac{1}{k} F_x$. Assume that the lowpass filter is $h(n)$ of length $M = kI$ (see fig 10.18)

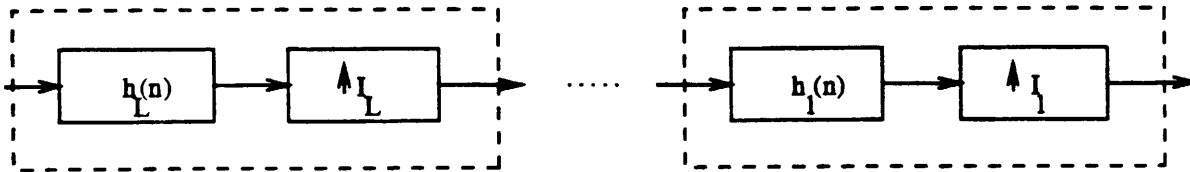

Figure 10.16:

10.19

(a)

$$\begin{aligned}
 \text{for any } n &= lI + j \quad (0 \leq j \leq I-1) \\
 \sum_{k=0}^{I-1} p_k(n-k) &= \sum_{k=0}^{I-1} p_k(lI + j - k) \\
 &= p_j(lI) \\
 &= p_j(l) \\
 &= h(j + lI) \\
 &= h(n)
 \end{aligned}$$

$$\text{Therefore, } h(n) = \sum_{k=0}^{I-1} p_k(n-k)$$

(b) z-transform both sides

$$H(z) = \sum_{k=0}^{I-1} z^{-k} p_k(z)$$

(c)

$$\frac{1}{I} \sum_n \sum_{l=0}^{I-1} h(n) e^{j \frac{2\pi l(n-k)}{I}} z^{-\frac{n-k}{I}}$$

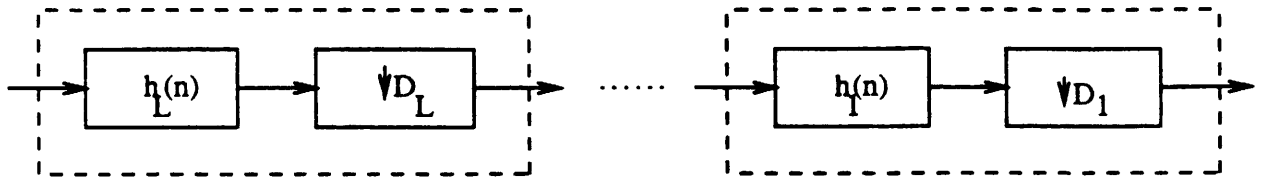

Figure 10.17: L -stage decimator

$$\begin{aligned}
 &= \frac{1}{L} \sum_m \sum_{l=0}^{L-1} h(k + mL) e^{j2\pi lm} z^{-m} \\
 &= \sum_m h(k + mL) z^{-m} \\
 &= \sum_m p_k(m) z^{-m} \\
 &= p_k(z)
 \end{aligned}$$

10.20

(a) Refer to fig 10.19.

(b)

$$\begin{aligned}
 \text{Bandwidth} &= \frac{\pi}{3} \\
 \text{cut off freq} &= \frac{\pi}{2} \\
 \text{sampling freq of } x(n) &= 2\pi \\
 \text{sampling freq for the desired band of frequencies} &= \frac{2\pi}{2} = \pi \\
 \text{Therefore, } D &= \frac{2\pi}{\pi} = 2
 \end{aligned}$$

(c) Refer to fig 10.20.

(d) Refer to fig 10.21.

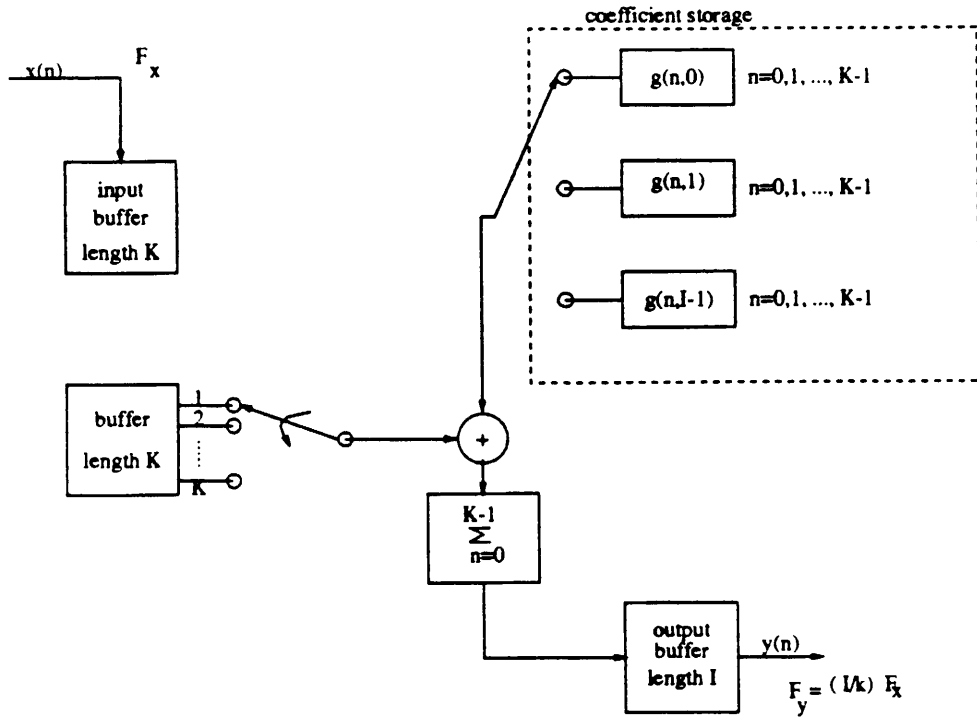

Figure 10.18:

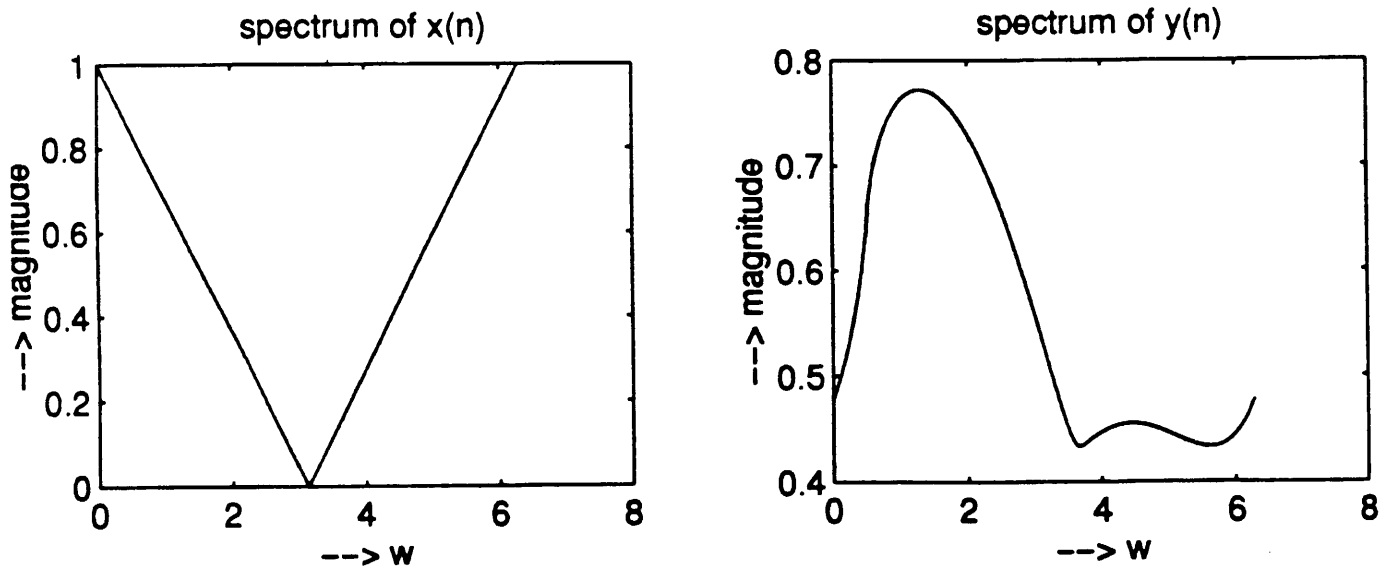

Figure 10.19:

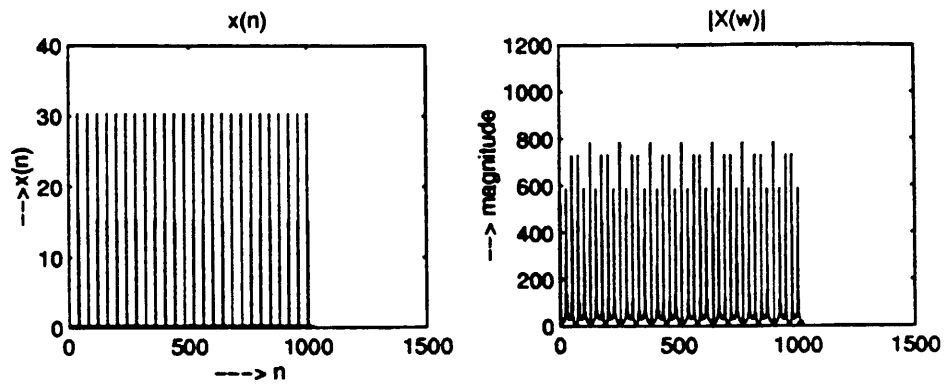

Figure 10.20:

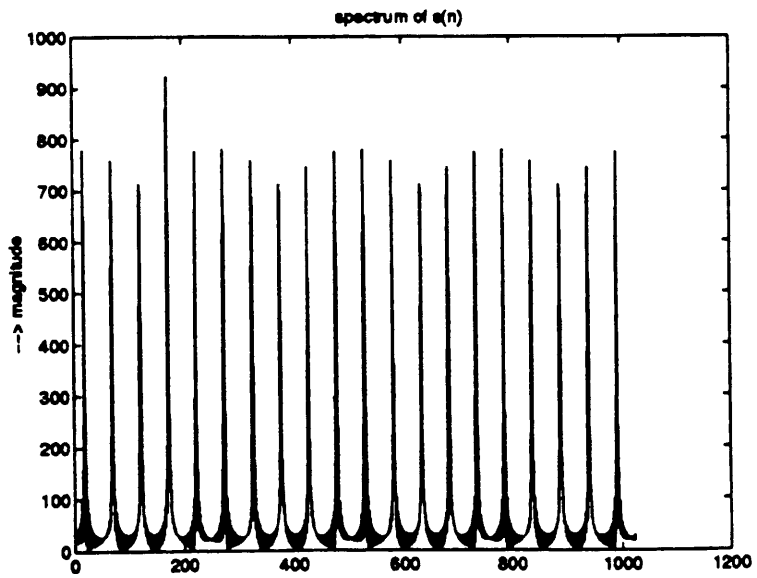

Figure 10.21:

Chapter 11

11.1

(a)

$$\begin{aligned}\Gamma_{xx}(z) &= \frac{25}{(1 - z^{-1} + \frac{1}{2}z^{-2})(1 - z^{-1} + \frac{1}{2}z^{-2})} \\ H(z) &= \frac{1}{1 - z^{-1} + \frac{1}{2}z^{-2}} \\ \text{and } \sigma_w^2 &= 25 \\ \text{so } x(n) &= x(n-1) - \frac{1}{2}x(n-2) + w(n)\end{aligned}$$

(b) The whitening filter is $H^{-1}(z) = 1 - z^{-1} + \frac{1}{2}z^{-2}$

11.2

$$(a) \Gamma_{xx}(z) = \frac{27}{2} \frac{(1 - \frac{1}{3}z^{-1})(1 - \frac{1}{3}z)}{(1 - \frac{1}{2}z^{-1})(1 - \frac{1}{2}z)}$$

For a stable filter, denominator $(1 - \frac{1}{2}z^{-1})$ must be chose. However, either numerator factor may be used. $H(z) = \underbrace{\frac{(1 - \frac{1}{3}z^{-1})}{(1 - \frac{1}{2}z^{-1})}}_{[\text{min. pk.}]}$ or $\frac{(1 - \frac{1}{3}z)}{(1 - \frac{1}{2}z)}$

(b) Must invert the min. pk. filter to obtain a stable whitening filter.

$$H^{-1}(z) = \frac{(1 - \frac{1}{2}z^{-1})}{(1 - \frac{1}{3}z^{-1})}$$

11.3

(a)

$$\begin{aligned}H(z) &= \frac{1 + 0.9z^{-1}}{1 - 1.6z^{-1} + 0.63z^{-2}} \\ \text{whitening filter, } H^{-1}(z) &= \frac{1 - 1.6z^{-1} + 0.63z^{-2}}{1 + 0.9z^{-1}} \\ \text{zeros: } z &= 0.7 \text{ and } 0.9 \\ \text{pole: } z &= -0.9\end{aligned}$$

(b)

$$\begin{aligned}\Gamma_{xx}(w) &= \sigma_w^2 H(w)H(-w) \\ &= \sigma_w^2 \frac{|1 + 0.9e^{-jw}|^2}{|1 - 1.6e^{-jw} + 0.63e^{-2jw}|^2}\end{aligned}$$

11.4

$$\begin{aligned}A(z) &= 1 + \frac{13}{24}z^{-1} + \frac{5}{8}z^{-2} + \frac{1}{3}z^{-3} \\ k_3 &= \frac{1}{3} \\ B_3(z) &= \frac{1}{3} + \frac{5}{8}z^{-1} + \frac{13}{24}z^{-2} + z^{-3} \\ k_3 &= \frac{1}{2} \\ B_2(z) &= \frac{1}{2} + \frac{3}{8}z^{-1} + z^{-2} \\ A_1(z) &= \frac{A_2(z) - k_2 B_2(z)}{1 - k_2^2} \\ &= 1 + \frac{1}{4}z^{-1} \\ k_1 &= \frac{1}{4}\end{aligned}$$

11.5

$$\begin{aligned}A_2(z) &= 1 + 2z^{-1} + \frac{1}{3}z^{-2} \\ B_2(z) &= \frac{1}{3} + 2z^{-1} + z^{-2} \\ k_2 &= \frac{1}{3} \\ A_1(z) &= \frac{A_2(z) - k_2 B_2(z)}{1 - k_2^2} \\ &= 1 + \frac{3}{2}z^{-1} \\ k_1 &= \frac{3}{2}\end{aligned}$$

11.6

(a)

$$\begin{aligned}A_1(z) &= 1 + \frac{1}{2}z^{-1} \\ B_1(z) &= \frac{1}{2} + z^{-1} \\ A_2(z) &= A_1(z) + k_2 B_1(z)z^{-1} \\ &= 1 + \frac{1}{3}z^{-1} - \frac{1}{3}z^{-2}\end{aligned}$$

$$\begin{aligned}
 B_2(z) &= -\frac{1}{3} + \frac{1}{3}z^{-1} + z^{-2} \\
 H(z) = A_3(z) &= A_2(z) + k_3 B_2(z)z^{-1} \\
 &= 1 + z^{-3} \\
 \text{The zeros are at } z &= -1, e^{\pm j\frac{2\pi}{3}}
 \end{aligned}$$

Refer to fig 11.1
(b)

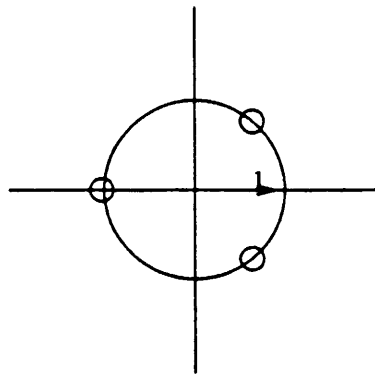

Figure 11.1:

$$\begin{aligned}
 \text{If } k_3 &= -1, \text{ we have} \\
 H(z) = A_3(z) &= A_2(z) - B_2(z)z^{-1} \\
 &= 1 + \frac{2}{3}z^{-1} - \frac{2}{3}z^{-2} - z^{-3} \\
 \text{The zeros are at } z &= -1, -\frac{5}{6} \pm j\frac{\sqrt{11}}{6}
 \end{aligned}$$

(c) If $|k_p| = 1$, the zeros of $H(z) = A_p(z)$ are on the unit circle. Refer to fig 11.2.

11.7

$$\begin{aligned}
 A_1(z) &= 1 + 0.6z^{-1} \\
 B_1(z) &= 0.6 + z^{-1}
 \end{aligned}$$

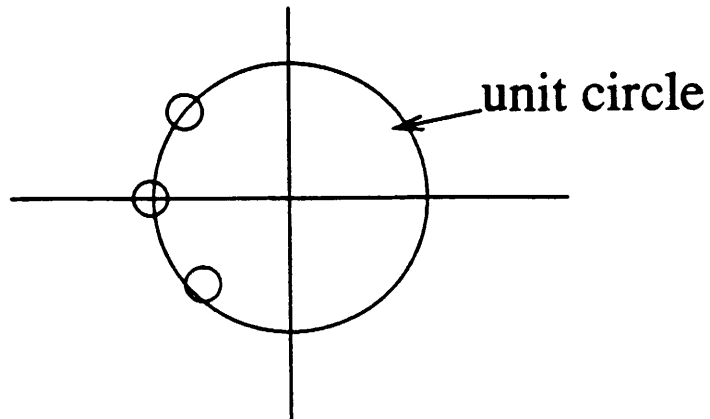

Figure 11.2:

$$\begin{aligned}
 A_2(z) &= A_1(z) + k_2 B_1(z) z^{-1} \\
 &= 1 + 0.78z^{-1} + 0.3z^{-2} \\
 B_2(z) &= 0.3 + 0.78z^{-1} + z^{-2} \\
 A_3(z) &= A_2(z) + 0.52 B_2(z) z^{-1} \\
 &= 1 + 0.93z^{-1} + 0.69z^{-2} + 0.5z^{-3} \\
 B_3(z) &= 0.5 + 0.69z^{-1} + 0.93z^{-2} + z^{-3} \\
 H_3(z) &= A_3(z) + 0.9 B_3(z) z^{-1} \\
 &= 1 + 1.38z^{-1} + 1.311z^{-2} + 1.337z^{-3} + 0.9z^{-4} \\
 h(n) &= \left\{ \underset{\uparrow}{1}, 1.38, 1.311, 1.337, 0.9, 0, \dots \right\}
 \end{aligned}$$

11.8

Let $y(m) = x(2n - p - m)$. Then, the backward prediction of $x(n - p)$ becomes the forward prediction of $y(n)$. Hence, its linear prediction error filter is just the noise whitening filter of the corresponding anticausal AR(p) process.

11.9

$$\hat{x}(n+m) = - \sum_{k=1}^p a_p(k) x(n-k)$$

$$\begin{aligned}
e(n) &= x(n+m) - \hat{x}(n+m) \\
&= x(n+m) + \sum_{k=1}^p a_p(k)x(n-k) \\
E[e(n)x^*(n-l)] &= 0, \quad l = 1, 2, \dots, p \\
\Rightarrow \sum_{k=1}^p a_p(k)\gamma_{xx}(k-l) &= -\gamma_{xx}(l+m), \quad l = 1, 2, \dots, p
\end{aligned}$$

The minimum error is

$$\begin{aligned}
E\{|e(n)|^2\} &= E[e(n)x^*(n+m)] \\
&= \gamma_{xx}(0) + \sum_{k=1}^p a_p(k)\gamma_{xx}(m+k)
\end{aligned}$$

Refer to fig 11.3.

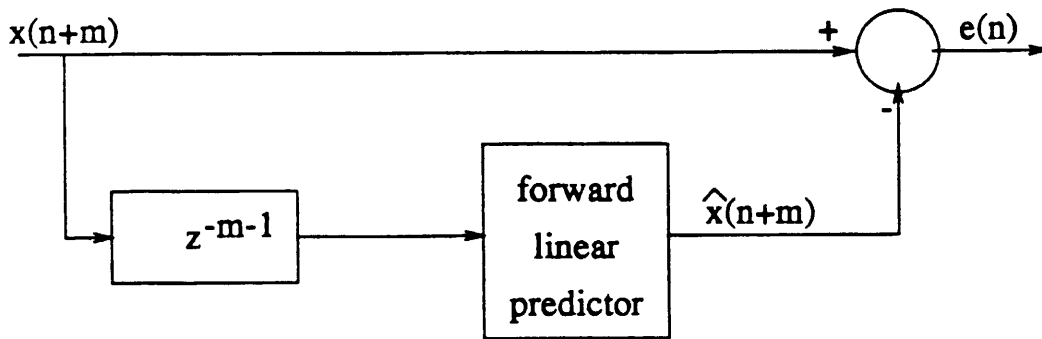

Figure 11.3:

11.10

$$\begin{aligned}
\hat{x}(n-p-m) &= -\sum_{k=0}^{p-1} b_p(k)x(n-k) \\
e(n) &= x(n-p-m) - \hat{x}(n-p-m)
\end{aligned}$$

$$\begin{aligned}
&= x(n-p-m) + \sum_{k=0}^{p-1} b_p(k)x(n-k) \\
E[e(n)x^*(n-l)] &= 0, \quad l = 0, 2, \dots, p-1 \\
\Rightarrow \sum_{k=0}^{p-1} b_p(k)\gamma_{xx}(l-k) &= -\gamma_{xx}(l-p-m), \quad l = 0, 2, \dots, p-1
\end{aligned}$$

The minimum error is

$$\begin{aligned}
E\{|e(n)|^2\} &= E[e(n)x^*(n-p-m)] \\
&= \gamma_{xx}(0) + \sum_{k=0}^{p-1} b_p(k)\gamma_{xx}(p+m-k)
\end{aligned}$$

Refer to fig 11.4.

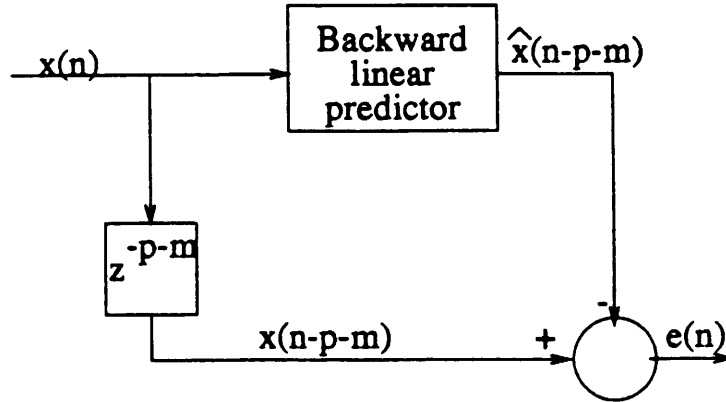

Figure 11.4:

11.11

The Levinson-Durbin algorithm for the forward filter coefficients is

$$\begin{aligned}
a_m(m) \equiv k_m &= -\frac{\gamma_{xx}(m) + \gamma_{m-1}^b a_{m-1}}{E_m^f} \\
a_m(k) &= a_{m-1}(k) + k_m a_{m-1}^*(m-k), \\
&\quad k = 1, 2, \dots, m-1; \quad m = 1, 2, \dots, p
\end{aligned}$$

$$\begin{aligned} \text{but } b_m(k) &= a_m^*(m-k), \quad k = 0, 2, \dots, m \\ \text{or } a_m(k) &= b_m^*(m-k) \end{aligned}$$

$$\text{Therefore, } b_m^*(0) \equiv k_m = -\frac{\gamma_{xx}(m) + \gamma_{m-1}^t \underline{b}_{m-1}^*}{E_m^b}$$

$$b_m^*(m-k) = b_{m-1}^*(m-1-k) + k_m b_{m-1}(k)$$

$$\text{Equivalently, } b_m(0) = k_m^* = \frac{\gamma_{xx}(m) + \gamma_{m-1}^t \underline{b}_{m-1}^*}{E_m^b}$$

$$b_m(k) = b_{m-1}(k-1) + k_m^* b_{m-1}^*(m-k)$$

This is the Levinson-Durbin algorithm for the backward filter.

11.12

Let

$$\underline{b}_m = \begin{bmatrix} \underline{b}_{m-1} \\ 0 \end{bmatrix} + \begin{bmatrix} \underline{d}_{m-1} \\ b_m(m) \end{bmatrix}$$

Then,

$$\begin{bmatrix} \underline{\Gamma}_{m-1} & \underline{\gamma}_{m-1}^{b^*} \\ \underline{\gamma}_{m-1}^{bt} & \gamma_{xx}(0) \end{bmatrix} \left\{ \underline{b}_m = \begin{bmatrix} \underline{b}_{m-1} \\ 0 \end{bmatrix} + \begin{bmatrix} \underline{d}_{m-1} \\ b_m(m) \end{bmatrix} \right\} = \begin{bmatrix} \underline{c}_{m-1} \\ c_m(m) \end{bmatrix}$$

Hence,

$$\underline{\Gamma}_{m-1} \underline{b}_{m-1} + \underline{\Gamma}_{m-1} \underline{d}_{m-1} + b_m(m) \underline{\gamma}_{m-1}^{b^*} = \underline{c}_{m-1}$$

$$\underline{\gamma}_{m-1}^{bt} \underline{b}_{m-1} + \underline{\gamma}_{m-1}^{bt} \underline{d}_{m-1} + b_m(m) \gamma_{xx}(0) = c_m(m)$$

$$\text{But } \underline{\Gamma}_{m-1} \underline{b}_{m-1} = \underline{c}_{m-1}$$

$$\Rightarrow \underline{\Gamma}_{m-1} \underline{d}_{m-1} = -b_m(m) \underline{\gamma}_{m-1}^{b^*}$$

$$\text{Hence, } \underline{d}_{m-1} = -b_m(m) \underline{\Gamma}_{m-1}^{-1} \underline{\gamma}_{m-1}^{b^*}$$

$$\text{Also, } \underline{\Gamma}_{m-1}^{-1} \underline{\gamma}_{m-1}^{b^*} = \underline{a}_{m-1}^{b^*}$$

$$\text{Therefore, } b_m(m) \underline{\gamma}_{m-1}^{bt} \underline{a}_{m-1}^{b^*} + b_m(m) \gamma_{xx}(0) = c_m(m) - \underline{\gamma}_{m-1}^{bt} \underline{b}_{m-1}$$

solving for $b_m(m)$, we obtain

$$\begin{aligned} b_m(m) &= \frac{c_m(m) - \underline{\gamma}_{m-1}^{bt} \underline{b}_{m-1}}{\gamma_{xx}(0) + \underline{\gamma}_{m-1}^{bt} \underline{a}_{m-1}^{b^*}} \\ &= \frac{c_m(m) - \underline{\gamma}_{m-1}^{bt} \underline{b}_{m-1}}{E_{m-1}^f} \end{aligned}$$

we also obtain the recursion

$$\begin{aligned} b_m(k) &= b_{m-1}(k) + b_m(m) a_{m-1}^*(m-k), \\ & \quad k = 1, 2, \dots, m-1 \end{aligned}$$

11.13

Equations for the forward linear predictor:

$$\underline{\Gamma}_m \underline{a}_m = \underline{c}_m$$

where the elements of \underline{c}_m are $\gamma_{xx}(l+m)$, $l = 1, 2, \dots, p$. The solution of \underline{a}_m is

$$\begin{aligned} a_m(m) &= \frac{c_m(m) - \underline{\gamma}_{m-1}^{bt} a_{m-1}}{\gamma_{xx}(0) + \underline{\gamma}_{m-1}^{bt} a_{m-1}^{b*}} \\ &= \frac{c_m(m) - \underline{\gamma}_{m-1}^{bt} a_{m-1}}{E_{m-1}^J} \\ a_m(k) &= a_{m-1}(k) + a_m(m) \alpha_{m-1}^*(m-k), \\ & \quad k = 1, 2, \dots, m-1; \quad m = 1, 2, \dots, p \end{aligned}$$

where α_m is the solution to $\underline{\Gamma}_m \alpha_m = \underline{\gamma}_m$

The coefficients for the m-step backward predictor are $\underline{b}_m = \underline{a}_m^b$.

11.14

$$\begin{aligned} \underline{V}_m &= \begin{bmatrix} 1 & k_m \\ k_m^* & 1 \end{bmatrix} \\ \underline{V}_m J \underline{V}_m^{t*} &= \begin{bmatrix} 1 & k_m \\ k_m^* & 1 \end{bmatrix} \begin{bmatrix} 1 & 0 \\ 0 & -1 \end{bmatrix} \begin{bmatrix} 1 & k_m \\ k_m^* & 1 \end{bmatrix} \\ &= \begin{bmatrix} 1 & -k_m \\ k_m^* & -1 \end{bmatrix} \begin{bmatrix} 1 & k_m \\ k_m^* & 1 \end{bmatrix} = \begin{bmatrix} 1 - |k_m|^2 & 0 \\ 0 & -(1 - |k_m|^2) \end{bmatrix} \\ &= (1 - |k_m|^2) \begin{bmatrix} 1 & 0 \\ 0 & -1 \end{bmatrix} = (1 - |k_m|^2) J \end{aligned}$$

11.15

(a)

$$\begin{aligned} E[f_m(n)x(n-i)] &= E\left[\sum_{k=0}^m a_m(k)x(n-k)x(n-i)\right] \\ &= 0, \text{ by the orthogonality property} \end{aligned}$$

(b)

$$\begin{aligned} E[g_m(n)x(n-i)] &= \sum_{k=0}^m a_m^*(k) E[x(n-m+k)x(n-i)] \\ &= \sum_{k=0}^m a_m^*(k) \gamma_{xx}(k-m+i) \\ &= 0, \quad i = 0, 1, \dots, m-1 \end{aligned}$$

(c)

$$E[f_m(n)x(n)] = E\left\{f_m(n)\left[f_m(n) - \sum_{k=1}^m a_m(k)x(n-k)\right]\right\}$$

$$\begin{aligned}
&= E\{|f_m(n)|^2\} \\
&= E_m \\
E[g_m(n)x(n-m)] &= E\{g_m(n)[g_m(n) - \sum_{k=0}^{m-1} b_m(k)x(n-k)]\} \\
&= E\{|g_m(n)|^2\} \\
&= E_m
\end{aligned}$$

(d)

$$\begin{aligned}
E[f_i(n)f_j(n)] &= E\{f_i(n)[x(n) + \sum_{k=1}^j a_j(k)x(n-k)]\} \\
&= E\{f_i(n)x(n)\} \\
&= E_i \\
&= E_{\max(i,j)}
\end{aligned}$$

where $i > j$ has been assumed

(e)

$$E[f_i(n)f_j(n-t)] = E\{f_i(n)[x(n-t) + \sum_{k=1}^j a_j(k)x(n-t-k)]\}$$

when $0 \leq t \leq i-j$, $x(n-t-1), x(n-t-2), \dots, x(n-t-j)$ are just a subset of $x(n-1), x(n-2), \dots, x(n-i)$ Hence, from the orthogonality principle,

$$E[f_i(n)f_j(n-t)] = 0$$

Also, when $-1 \geq t \geq i-j$ holds, via the same method we have

$$E[f_i(n)f_j(n-t)] = 0$$

(f)

$$E[g_i(n)g_j(n-t)] = E\{g_i(n)[x(n-t-j) + \sum_{k=0}^{j-1} b_j(k)x(n-t-k)]\}$$

when $0 \leq t \leq i-j$, $\{x(n-t), x(n-t-1), \dots, x(n-t-j)\}$ is a subset of $\{x(n), \dots, x(n-i+1)\}$ Hence, from the orthogonality principle,

$$E[g_i(n)g_j(n-t)] = 0$$

Also, when $0 \geq t \geq i-j+1$ we obtain the same result (g)

$$\begin{aligned}
\text{for } i = j, E\{f_i(n+i)f_j(n+j)\} &= E\{f_i^2(n+i)\} \\
&= E_i
\end{aligned}$$

for $i \neq j$, suppose that $i > j$. Then

$$\begin{aligned}
E\{f_i(n+i)f_j(n+j)\} &= E\{f_i(n+i)[x(n+j) + \sum_{k=1}^j a_j(k)x(n+j-k)]\} \\
&= 0
\end{aligned}$$

(h)

suppose $i > j$

$$\begin{aligned}
E\{g_i(n+i)g_j(n+j)\} &= E\{g_i(n+i)[x(n) + \sum_{k=0}^{j-1} b_j(k)x(n+j-k)]\} \\
&= E[g_i(n+i)x(n)] \\
&= E_i
\end{aligned}$$

(i)

for $i \geq j$

$$\begin{aligned}
E\{f_i(n)g_j(n)\} &= E\{f_i(n)[x(n-j) + \sum_{k=0}^{j-1} b_j(k)x(n-k)]\} \\
&= E\{f_i(n)[b_j(0)x(n)]\} \\
&= k_j E\{f_i(n)x(n)\} \\
&= k_j E_i
\end{aligned}$$

for $i < j$,

$$\begin{aligned}
E\{f_i(n)g_j(n)\} &= E\{g_j(n)[x(n) + \sum_{k=1}^i a_i(k)x(n-k)]\} \\
&= 0
\end{aligned}$$

(j)

$$\begin{aligned}
E\{f_i(n)g_i(n-1)\} &= E\{f_i(n)[x(n-1-j) + \sum_{k=0}^{i-1} b_i(k)x(n-1-k)]\} \\
&= E\{f_i(n)x(n-1-i)\} \\
&= E\{f_i(n)[g_{i+1}(n) - \sum_{k=0}^i b_{i+1}(k)x(n-k)]\} \\
&= -E\{f_i(n)b_{i+1}(0)x(n)\} \\
&= -k_{i+1}E_i
\end{aligned}$$

(k)

$$\begin{aligned}
E\{g_i(n-1)x(n)\} &= E\{g_i(n-1)[f_{i+1}(n) - \sum_{k=1}^{i+1} a_{i+1}(k)x(n-k)]\} \\
&= -E\{g_i(n-1)a_{i+1}(i+1)x(n-1-i)\} \\
&= -k_{i+1}E_i \\
E\{f_i(n+1)x(n-i)\} &= E\{f_i(n+1)[f_i(n-i) - \sum_{k=1}^i a_i(k)x(n-i-k)]\}
\end{aligned}$$

(l)

suppose $i > j$

$$\begin{aligned}
E\{f_i(n)g_j(n-1)\} &= E\{f_i(n)[x(n-1-j) + \sum_{k=0}^{j-1} b_j(k)x(n-1-k)]\} \\
&= 0
\end{aligned}$$

Now, let $i \leq j$. then

$$\begin{aligned} E\{f_i(n)g_j(n-1)\} &= E\{g_j(n-1)[x(n) + \sum_{k=1}^i a_i(k)x(n-k)]\} \\ &= E\{g_j(n-1)x(n)\} \\ &= -k_{j+1}E_j \quad \text{from (d)} \end{aligned}$$

11.16

- (a) $E[f_m(n)x^*(n-i)] = 0, \quad 1 \leq i \leq m$
 (b) $E[g_m(n)x^*(n-i)] = 0, \quad 0 \leq i \leq m-1$
 (c) $E[f_m(n)x^*(n)] = E[g_m(n)x^*(n-m)] = E_m$
 (d) $E[f_i(n)f_j^*(n)] = E_{\max}(i, j)$
 (e)

$$E[f_i(n)f_j^*(n-t)] = 0, \text{ for } \begin{cases} 1 \leq t \leq i-j, & i > j \\ -1 \geq t \geq i-j, & i < j \end{cases}$$

(f)

$$E[g_i(n)g_j^*(n-t)] = 0, \text{ for } \begin{cases} 0 \leq t \leq i-j, & i > j \\ 0 \geq t \geq i-j+1, & i < j \end{cases}$$

(g)

$$E[f_i(n+i)f_j^*(n+j)] = \begin{cases} E_i, & i = j \\ 0, & i \neq j \end{cases}$$

(h) $E[g_i(n+i)g_j^*(n+j)] = E_{\max}(i, j)$

(i)

$$E[f_i(n)g_i^*(n)] = \begin{cases} k_j^* E_i, & i \geq j \\ 0, & i < j \end{cases}$$

(j) $E[f_i(n)g_i^*(n-1)] = -k_{i+1}^* E_i$

(k) $E[g_i(n-1)x^*(n)] = -k_{i+1}^* E_i$

(l)

$$E[f_i(n)g_j^*(n-1)] = \begin{cases} 0, & i < j \\ -k_{j+1}^* E_j, & i \leq j \end{cases}$$

11.17

$$\underline{G}_0 = \begin{bmatrix} 0 & \gamma_{xx}(1) & \gamma_{xx}(2) & \gamma_{xx}(3) \\ \gamma_{xx}(0) & \gamma_{xx}(1) & \gamma_{xx}(2) & \gamma_{xx}(3) \end{bmatrix}$$

$$\underline{G}_1 = \begin{bmatrix} 0 & \gamma_{xx}(1) & \gamma_{xx}(2) & \gamma_{xx}(3) \\ 0 & \gamma_{xx}(0) & \gamma_{xx}(1) & \gamma_{xx}(2) \end{bmatrix}$$

$$k_1 = -\frac{\gamma_{xx}(1)}{\gamma_{xx}(0)} \quad \underline{V}_1 = \begin{bmatrix} 1 & k_1 \\ k_1^* & 1 \end{bmatrix}$$

$$\underline{V}_1 \underline{G}_1 = \begin{bmatrix} 0 & 0 & \gamma_{xx}(2) + k_1 \gamma_{xx}(1) & \gamma_{xx}(3) + k_1 \gamma_{xx}(2) \\ 0 & \gamma_{xx}(0) + k_1^* \gamma_{xx}(1) & \gamma_{xx}(1) + k_1^* \gamma_{xx}(2) & \gamma_{xx}(2) + k_1^* \gamma_{xx}(3) \end{bmatrix}$$

$$\underline{G}_2 = \begin{bmatrix} 0 & 0 & \gamma_{xx}(2) + k_1 \gamma_{xx}(1) & \gamma_{xx}(3) + k_1 \gamma_{xx}(2) \\ 0 & 0 & \gamma_{xx}(0) + k_1^* \gamma_{xx}(1) & \gamma_{xx}(1) + k_1^* \gamma_{xx}(2) \end{bmatrix}$$

Therefore, $k_2 = -\frac{\gamma_{xx}(2) + k_1 \gamma_{xx}(1)}{\gamma_{xx}(0) + k_1^* \gamma_{xx}(1)} = \frac{\gamma_{xx}(0) \gamma_{xx}(2) - \gamma_{xx}^2(1)}{\gamma_{xx}^2(1) - \gamma_{xx}^2(0)}$

Let,

$$\underline{V}_2 = \begin{bmatrix} 1 & k_2 \\ k_2^* & 1 \end{bmatrix}$$

$$\underline{V}_2 \underline{G}_2 = \begin{bmatrix} 0 & 0 & 0 & A \\ 0 & 0 & k_2[\gamma_{xx}(2) + k_1 \gamma_{xx}(1)] + \gamma_{xx}(0) + k_1 \gamma_{xx}(1) & B \end{bmatrix}$$

where $A = \gamma_{xx}(3) + k_1 \gamma_{xx}(2) + k_1 k_2 \gamma_{xx}(2) + k_2 \gamma_{xx}(1)$, and

$$B = k_2 \gamma_{xx}(3) + k_1 k_2 \gamma_{xx}(2) + k_1 \gamma_{xx}(2) + \gamma_{xx}(1)$$

and therefore, $\underline{G}_3 = \begin{bmatrix} 0 & 0 & 0 & \gamma_{xx}(3) + k_1(1 + k_2) \gamma_{xx}(2) + k_2 \gamma_{xx}(1) \\ 0 & 0 & 0 & k_2 \gamma_{xx}(3) + k_1(1 + k_2) \gamma_{xx}(2) + \gamma_{xx}(1) \end{bmatrix}$

and

$$k_3 = -\frac{[\gamma_{xx}^2(1) - \gamma_{xx}^2(0)] \gamma_{xx}(3) + C}{[\gamma_{xx}(0) \gamma_{xx}(2) - \gamma_{xx}^2(1)] \gamma_{xx}(3) - \gamma_{xx}(1) \gamma_{xx}^2(2) + D}$$

where $C = 2\gamma_{xx}(0) \gamma_{xx}(1) \gamma_{xx}(2) - \gamma_{xx}(1) \gamma_{xx}^2(2) - \gamma_{xx}^3(1)$ and

$$D = \gamma_{xx}(0) \gamma_{xx}(1) \gamma_{xx}(2) + \gamma_{xx}^3(1) - \gamma_{xx}(1) \gamma_{xx}^2(0)$$

This is the same result obtained from the Levinson Algorithm.

11.18

The results of section 11.1 apply directly to this problem. We may express $\Gamma_{xx}(f)$ as

$$\Gamma_{xx}(f) = \sigma_w^2 |H(f)|^2$$

where $H(f)$ is a filter with transfer function

$$H(z) = \exp\left[\sum_{m=1}^{\infty} v(m) z^{-m}\right]$$

The prediction error filter whitens the input process, so that the output process is white with spectral density $\sigma_w^2 = \exp[v(0)]$. Therefore, the minimum MSE is

$$\begin{aligned} E'_{\infty} &= \int_{-\pi}^{\pi} \sigma_w^2 dw \\ &= \sigma_w^2 \int_{-\pi}^{\pi} dw \\ &= 2\pi \sigma_w^2 \\ &= 2\pi e^{v(0)} \end{aligned}$$

$$\text{But } v(0) = \int_{-\frac{1}{2}}^{\frac{1}{2}} \ln \Gamma_{xx}(f) df$$

$$\text{Therefore, } E'_{\infty} = 2\pi \exp\left[\int_{-\frac{1}{2}}^{\frac{1}{2}} \ln \Gamma_{xx}(f) df\right]$$

11.19

$$\Gamma_{xx}(z) = \frac{\sigma_w^2}{(1-az^{-1})(1-az)}$$

$$\Rightarrow G(z) = \frac{1}{1-az^{-1}}$$

Since $d(n) = x(n+m)$, we have

$$\begin{aligned} \gamma_{dx}(k) &= E\{d(n)x(n-k)\} \\ &= E\{x(n+m)x(n-k)\} \\ &= \gamma_{xx}(m+k) \end{aligned}$$

$$\text{Therefore, } \Gamma_{dx}(z) = z^M \Gamma_{xx}(z)$$

$$\left[\frac{\Gamma_{dx}(z)}{G(z^{-1})}\right]_+ = \left[\frac{z^m \sigma_w^2 (1-az)}{(1-az^{-1})(1-az)}\right]_+$$

$$= \left[\frac{\sigma_w^2 z^m}{1-az^{-1}}\right]_+$$

$$= \frac{a^m}{1-az^{-1}} \sigma_w^2$$

$$\begin{aligned} H_{\text{opt}}(z) &= \frac{1}{\sigma_w^2} (1-az^{-1}) \frac{a^m}{1-az^{-1}} \sigma_w^2 \\ &= a^m \end{aligned}$$

$$h_{\text{opt}}(n) = a^m \delta(n)$$

$$\text{the output is } y(n) = h_{\text{opt}}(n) * x(n)$$

$$= a^m x(m)$$

$$\text{MMSE}_{\infty} = \gamma_{xx}(0) - \sum_{k=0}^{\infty} h_{\text{opt}}(k) \gamma_{dx}(k)$$

$$= \gamma_{xx}(0) - a^m \gamma_{dx}(0)$$

$$= \gamma_{xx}(0) - a^m \gamma_{xx}(m)$$

$$= \frac{\sigma_w^2}{1-a^2} - a^m \frac{a^m \sigma_w^2}{1-a^2}$$

$$= \frac{1-a^{2m}}{1-a^2} \sigma_w^2$$

11.20

(a)

$$\underline{G}_0 = \begin{bmatrix} 0 & \frac{1}{2} & \frac{1}{8} & \frac{1}{64} \\ 1 & \frac{1}{2} & \frac{1}{8} & \frac{1}{64} \end{bmatrix}$$

$$\underline{G}_1 = \begin{bmatrix} 0 & \frac{1}{2} & \frac{1}{8} & \frac{1}{64} \\ 0 & 1 & \frac{1}{2} & \frac{1}{8} \end{bmatrix} \Rightarrow k_1 = -\frac{1}{2}$$

$$\underline{V}_1 = \begin{bmatrix} 1 & -\frac{1}{2} \\ -\frac{1}{2} & 1 \end{bmatrix}$$

$$\underline{V}_1 \underline{G}_1 = \begin{bmatrix} 0 & 0 & -\frac{1}{8} & -\frac{3}{64} \\ 0 & \frac{3}{4} & \frac{7}{16} & \frac{13}{128} \end{bmatrix}$$

$$\underline{G}_2 = \begin{bmatrix} 0 & 0 & -\frac{1}{8} & -\frac{3}{64} \\ 0 & 0 & \frac{3}{4} & \frac{7}{16} \end{bmatrix} \Rightarrow k_2 = \frac{2}{3}$$

$$\underline{V}_2 = \begin{bmatrix} 1 & -\frac{2}{3} \\ \frac{2}{3} & 1 \end{bmatrix}$$

$$\underline{V}_2 \underline{G}_2 = \begin{bmatrix} 0 & 0 & 0 & \frac{47}{192} \\ 0 & 0 & \frac{2}{3} & \frac{13}{32} \end{bmatrix}$$

$$\underline{G}_3 = \begin{bmatrix} 0 & 0 & 0 & \frac{47}{192} \\ 0 & 0 & 0 & \frac{2}{3} \end{bmatrix} \Rightarrow k_3 = \frac{47}{128}$$

(b) Refer to fig 11.5

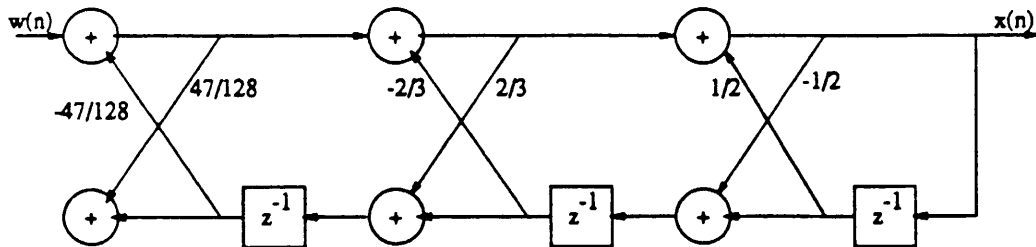

Figure 11.5:

11.21

$$\begin{aligned}
 \Gamma_{xx}(f) &= \sum_{k=-\infty}^{\infty} \gamma_{xx}(k) e^{-j2\pi f k} \\
 A_m(f) &= \sum_{p=0}^m a_m(p) e^{-j2\pi f p} \\
 A_n^*(f) &= \sum_{q=0}^n a_n^*(q) e^{j2\pi f q} \\
 \int_{-\frac{1}{2}}^{\frac{1}{2}} \Gamma_{xx}(f) A_m(f) A_n^*(f) df &= \sum_k \sum_p \sum_q \gamma_{xx}(k) a_m(p) a_n^*(q) \int_{-\frac{1}{2}}^{\frac{1}{2}} e^{-j2\pi f(k+p+q)} df \\
 &= \sum_{k=-\infty}^{\infty} \sum_{p=0}^m \sum_{q=0}^n \gamma_{xx}(k) a_m(p) a_n^*(q) \delta(q-p-k) \\
 &= \sum_{p=0}^m \sum_{q=0}^n \gamma_{xx}(q-p) a_m(p) a_n^*(q) \\
 &= \sum_p \sum_q E[x(l+q)x^*(l+p)] a_m(p) a_n^*(q) \\
 &= E \left\{ \sum_{p=0}^m a_m(p) x^*(l+p) \sum_{q=0}^n a_n^*(q) x(l+p) \right\} \\
 &= E \{ f_m(l+m) f_n^*(l+n) \} \\
 &= E_m \delta_{mn}
 \end{aligned}$$

where the last step follows from prob. 11.16 property (g)

11.22

$$\begin{aligned}
 A_1(z) &= 1 + 0.6z^{-1} \\
 B_1(z) &= 0.6 + z^{-1} \\
 A_2(z) &= A_1(z) + k_2 B_1(z) z^{-1} \\
 &= 1 + 0.78z^{-1} + 0.3z^{-2} \\
 B_2(z) &= 0.3 + 0.78z^{-1} + z^{-2} \\
 A_3(z) &= A_2(z) + k_3 B_2(z) z^{-1} \\
 &= 1 + 0.93z^{-1} + 0.69z^{-2} + 0.5z^{-3} \\
 B_3(z) &= 0.5 + 0.69z^{-1} + 0.93z^{-2} + z^{-3} \\
 A_4(z) &= A_3(z) + k_4 B_3(z) z^{-1} \\
 &= 1 + 1.38z^{-1} + 1.311z^{-2} + 1.337z^{-3} + 0.9z^{-4} \\
 H(z) &= \frac{1}{A_4(z)}
 \end{aligned}$$

11.23

$$A_2(z) = 1 + 0.1z^{-1} - 0.72z^{-2}$$

$$\begin{aligned}
 k_2 &= -0.72 \\
 B_2(z) &= -0.72 + 0.1z^{-1} + z^{-2} \\
 A_1(z) &= \frac{A_2(z) - k_2 B_2(z)}{1 - k_2^2} \\
 &= 1 + 0.357z^{-1} \\
 k_1 &= 0.357 \\
 B_1(z) &= 0.357 + z^{-1} \\
 A_0(z) &= B_0(z) = 1 \\
 C_2(z) &= \beta_0 B_0(z) + \beta_1 B_1(z) + \beta_2 B_2(z) \\
 &= \beta_0 + \beta_1(0.357 + z^{-1}) + \beta_2(-0.72 + 0.1z^{-1} + z^{-2}) \\
 &= 1 - 0.8z^{-1} + 0.15z^{-2}
 \end{aligned}$$

Hence, $\beta_0 = 1.399$
 $\beta_1 = -0.815$
 $\beta_2 = 0.15$

Refer to fig 11.6

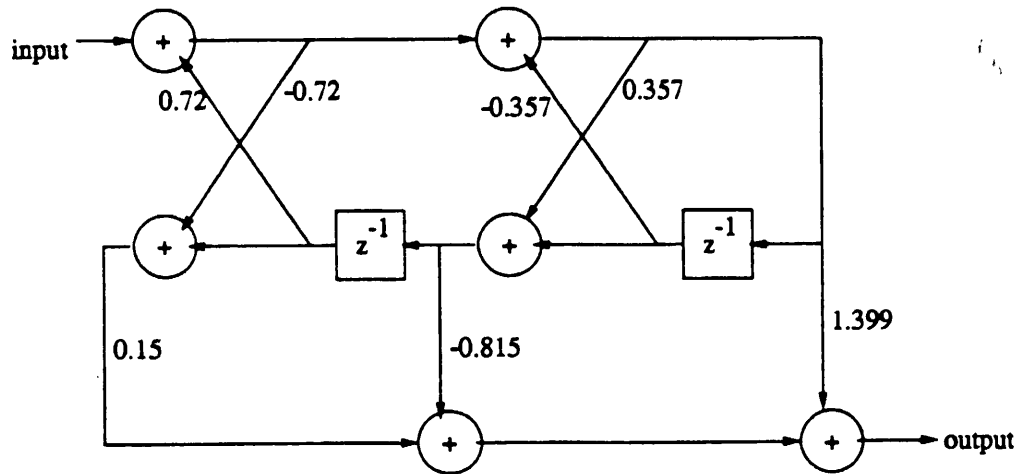

Figure 11.6:

11.24

Refer to fig 11.7 $h^*(n)$ minimizes $E[e^2(n)]$ (wiener filter) length $M = 2$ (a)

$$\Gamma_{ss}(w) = \sigma_v^2 |H(w)|^2$$

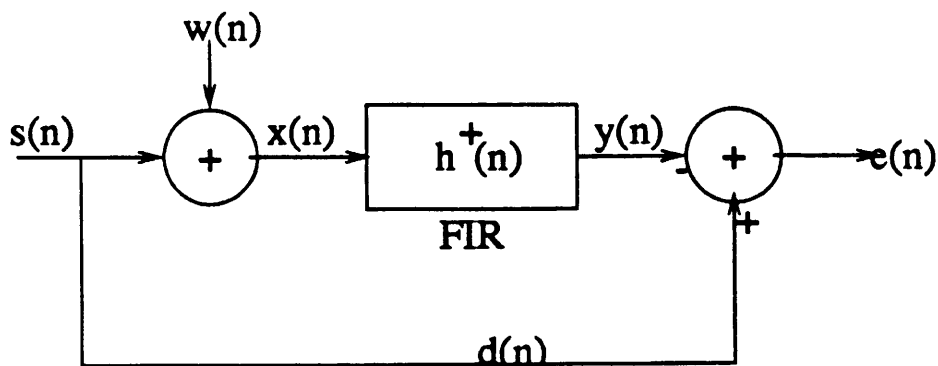

Figure 11.7:

$$\Gamma_{ss}(z) = \frac{0.49}{(1 - 0.8z^{-1})(1 - 0.8z)}$$

We can either formally invert this z-transform, or use the following idea: The inverse z-transform of 11.1 will have the form

$$\gamma_{ss}(m) = \gamma_{ss}(0)(0.8)^{|m|}$$

From the AR model for $s(n)$ it is easy to show

$$\begin{aligned} \gamma_{ss}(0) &= 0.8\gamma_{ss}(1) + \gamma_{sv}(0) \\ &= 0.8\gamma_{ss}(1) + \delta^2 \\ \text{and } \gamma_{ss}(1) &= 0.8\gamma_{ss}(0) + \gamma_{sv}(1) \\ &= 0.8\gamma_{ss}(0) \\ \text{solve for } \gamma_{ss}(0) &= \frac{49}{36} \\ \text{so } \gamma_{ss}(m) &= \frac{49}{36} \left(\frac{4}{5}\right)^{|m|} \\ \text{Now } \gamma_{ss}(m) &= E[x(n)x(n-m)] \\ &= E\{[s(n) + w(n)][s(n-m) + w(n-m)]\} \\ &= \gamma_{ss}(m) + \sigma_w^2 \delta(m) \\ &= \frac{49}{36} \left(\frac{4}{5}\right)^{|m|} + \delta(m) \end{aligned}$$

(b)

$$\begin{aligned} d(n) &= s(n) \\ \gamma_{dx}(l) = \gamma_{sx}(l) &= E[s(n)x(n-l)] \\ &= E\{s(n)[s(n-l) + w(n-l)]\} \\ &= \gamma_{ss}(l) \end{aligned}$$

So the normal equations are

$$\begin{bmatrix} 1 + \frac{49}{36} & \frac{49}{36} \frac{4}{5} \\ \frac{49}{36} \frac{4}{5} & 1 + \frac{49}{36} \end{bmatrix} \begin{bmatrix} h^t(0) \\ h^t(1) \end{bmatrix} = \begin{bmatrix} \frac{49}{36} \\ \frac{49}{36} \frac{4}{5} \end{bmatrix}$$

$$h^t(0) = 0.462, \quad h^t(1) = 0.248$$

$$(c) \xi = \text{MMSE}_2 = \frac{49}{36} - 0.462 \times \frac{49}{36} - 0.248 \times \frac{49}{36} \times \frac{4}{5} = 0.462$$

11.25

$$\begin{aligned} \Gamma_{dx}(z) &= \Gamma_{ss}(z) \\ &= \frac{0.49}{(1 - 0.8z^{-1})(1 - 0.8z)} \\ \Gamma_{xx}(z) &= \Gamma_{ss}(z) + 1 \\ &= \frac{1.78(1 - 0.45z^{-1})(1 - 0.45z)}{(1 - 0.8z^{-1})(1 - 0.8z)} \\ G(z) &= \frac{(1 - 0.45z^{-1})}{(1 - 0.8z^{-1})} \\ \left[\frac{\Gamma_{dx}(z)}{G(z^{-1})} \right]_+ &= \left[\frac{0.49}{(1 - 0.8z^{-1})(1 - 0.45z)} \right]_+ \\ &= \left[\frac{0.766}{1 - 0.8z^{-1}} + \frac{0.345z}{1 - 0.45z} \right]_+ \\ &= \frac{0.766}{1 - 0.8z^{-1}} \\ H_c^+(z) &= \frac{1}{1.78} \frac{1 - 0.8z^{-1}}{1 - 0.45z^{-1}} \frac{0.766}{1 - 0.8z^{-1}} \\ &= \frac{0.43}{1 - 0.45z^{-1}} \\ h_c^+(n) &= 0.43(0.45)^n u(n) \\ \xi_c^+ = \text{MMSE}_\infty &= \frac{1}{2\pi j} \oint_c [\Gamma_{ss}(z) - H_c(z)\Gamma_{ss}(z^{-1})] z^{-1} dz \\ &= \frac{1}{2\pi j} \oint_c \frac{0.28}{(z - 0.45)(1 - 0.8z)} dz \\ &= 0.438 \end{aligned}$$

11.26

Using quantities in prob. 11-25,

$$\begin{aligned} H_{nc}^+(z) &= \frac{\Gamma_{dx}(z)}{\Gamma_{xx}(z)} \\ &= \frac{0.275}{(1 - 0.45z^{-1})(1 - 0.45z)} \\ \xi_{nc}^+ = \text{MMSE}_{nc} &= \frac{1}{2\pi j} \oint_c [\Gamma_{dd}(z) - H_{nc}^+(z)\Gamma_{dx}(z^{-1})] z^{-1} dz \end{aligned}$$

$$\begin{aligned}
&= \frac{1}{2\pi j} \oint_c \frac{0.275}{(z-0.45)(1-0.45z^{-1})} dz \\
&= 0.345
\end{aligned}$$

11.27

$$\gamma_{ss}(m) = (0.6)^{|m|}$$

$$\begin{bmatrix} 2 & 0.6 & 0.36 \\ 0.6 & 2 & 0.6 \\ 0.36 & 0.6 & 2 \end{bmatrix} \begin{bmatrix} h^+(0) \\ h^+(1) \\ h^+(2) \end{bmatrix} = \begin{bmatrix} 1 \\ 0.6 \\ 0.36 \end{bmatrix}$$

$$h^+(0) = 0.455, \quad h^+(1) = 0.15, \quad h^+(2) = 0.055$$

$$\xi_3 = \text{MMSE}_3 = 1 - 0.455 - 0.15 \times 0.6 - 0.055 \times 0.36 = 0.435$$

Increasing the length of the filter decreases the MMSE.

11.28

$$\begin{bmatrix} \gamma_{xx}(0) & \gamma_{xx}(1) & \gamma_{xx}(2) \\ \gamma_{xx}(1) & \gamma_{xx}(0) & \gamma_{xx}(1) \\ \gamma_{xx}(2) & \gamma_{xx}(1) & \gamma_{xx}(0) \end{bmatrix} \begin{bmatrix} 1 \\ -1 \\ 0.6 \end{bmatrix} = \begin{bmatrix} 1 \\ 0 \\ 0 \end{bmatrix} \sigma_w^2$$

$$\Rightarrow \begin{bmatrix} 1 & -1 & 0.6 \\ -1 & 1.6 & 0 \\ 0.6 & -1 & 1 \end{bmatrix} \begin{bmatrix} \gamma_{xx}(0) \\ \gamma_{xx}(1) \\ \gamma_{xx}(2) \end{bmatrix} = \begin{bmatrix} 1 \\ 0 \\ 0 \end{bmatrix} \sigma_w^2$$

$$\gamma_{xx}(0) = 2.5641, \quad \gamma_{xx}(1) = 1.6026, \quad \gamma_{xx}(2) = 0.064$$

$$\text{For } m \geq 3, \gamma_{xx}(m) = \gamma_{xx}(m-1) - 0.6\gamma_{xx}(m-2)$$

$$\text{For } m < 0, \gamma_{xx}(m) = \gamma_{xx}(-m)$$

11.29

$$\begin{aligned}
\Gamma_{ss}(z) &= \frac{\sigma_v^2}{(1 + \sum_{k=1}^p a_p(k)z^{-k})(1 + \sum_{k=1}^p a_p(k)z^k)} \\
\text{Let } a_p(0) &\triangleq 1 \\
\Gamma_{ss}(z) &= \frac{\sigma_v^2}{(\sum_{k=0}^p a_p(k)z^{-k})(\sum_{k=0}^p a_p(k)z^k)}
\end{aligned}$$

$$\begin{aligned}\Gamma_{ss}(z) &= \Gamma_{ss}(z) + \sigma_w^2 \\ &= \frac{\sigma_v^2 + \sigma_w^2 (\cdot)(\cdot)}{(\cdot)(\cdot)}\end{aligned}$$

$x(n)$ is ARMA(p,p). Suppose

$$\Gamma_{xx}(z) = \frac{(\sum_{k=0}^p b_p(k)z^{-k})(\sum_{k=0}^p b_p(k)z^k)}{(\sum_{k=0}^p a_p(k)z^{-k})(\sum_{k=0}^p a_p(k)z^k)}$$

Comparing parameters of the two numerators

$$\begin{aligned}\sigma_v^2 + \sigma_w^2 \sum_{k=0}^p a_p^2(k) &= \sigma_n^2 \sum_{k=0}^p b_p^2(k) \\ \sigma_w^2 \sum_{k=0}^{p-q} a_p(k)a_p(k+q) &= \sigma_n^2 \sum_{k=0}^{p-q} b_p(k)b_p(k+q) \quad q = 1, 2, \dots, p\end{aligned}$$

There are $p+1$ equations in $p+1$ unknown parameters $\sigma_n^2, b_p(1), \dots, b_p(p)$. Note that $b_p(0) = 1$.

Chapter 12

12.1

(a)

$$\begin{aligned}
 & \lim_{T_0 \rightarrow \infty} E \left[\frac{1}{2T_0} \left| \int_{-T_0}^{T_0} x(t) e^{-j2\pi Ft} dt \right|^2 \right] \\
 &= \lim_{T_0 \rightarrow \infty} E \left[\frac{1}{2T_0} \int_{-T_0}^{T_0} x(t) e^{-j2\pi Ft} dt \int_{-T_0}^{T_0} x^*(\tau) e^{j2\pi F\tau} d\tau \right] \\
 &= \lim_{T_0 \rightarrow \infty} \frac{1}{2T_0} \int_{-T_0}^{T_0} \int_{-T_0}^{T_0} E[x(t)x^*(\tau)] e^{-j2\pi F(t-\tau)} dt d\tau \\
 &= \lim_{T_0 \rightarrow \infty} \frac{1}{2T_0} \int_{-T_0}^{T_0} \int_{-T_0}^{T_0} \gamma_{xx}(t-\tau) e^{-j2\pi F(t-\tau)} dt d\tau \\
 &= \lim_{T_0 \rightarrow \infty} \frac{1}{2T_0} \int_{-T_0}^{T_0} \int_{t-T_0}^{t+T_0} \gamma_{xx}(\alpha) e^{-j2\pi F(\alpha)} dt d\alpha \\
 &= \int_{-\infty}^{\infty} \gamma_{xx}(\alpha) e^{-j2\pi F(\alpha)} d\alpha \\
 &= \gamma_{xx}(F)
 \end{aligned}$$

(b)

$$\begin{aligned}
 \gamma_{xx}(m) &= \frac{1}{N} \sum_{n=0}^{N-1} x(n+m)x^*(n) \\
 \sum_{m=-N}^N \gamma_{xx}(m) e^{-j2\pi fm} &= \sum_{m=-N}^N \frac{1}{N} \sum_{n=0}^{N-1} x(n+m)x^*(n) e^{-j2\pi fm} \\
 &= \sum_{n=0}^{N-1} \frac{1}{N} \sum_{l=n-N}^{n+N} x(l)x^*(n) e^{-j2\pi f(l-n)} \\
 &= \frac{1}{N} \sum_{n=0}^{N-1} \sum_{l=0}^{N-1} x(l)x^*(n) e^{-j2\pi fl} e^{j2\pi fn} \\
 &= \frac{1}{N} \left| \sum_{n=0}^{N-1} x(n) e^{-j2\pi fn} \right|^2
 \end{aligned}$$

12.2

$$\begin{aligned}
 E[|\gamma_{xx}(m)|^2] &= \frac{1}{N^2} \sum_{n=0}^{N-|m|-1} \sum_{n'=0}^{N-|m|-1} E[x^*(n)x(n+m)x(n')x^*(n'+m)] \\
 &= \frac{1}{N^2} \sum_n \sum_{n'} \{E[x^*(n)x(n+m)]E[x(n')x^*(n'+m)] \\
 &\quad + E[x^*(n)x(n')]E[x^*(n'+m)x(n+m)] \\
 &\quad + E[x^*(n)x^*(n'+m)]E[x(n')x(n+m)]\} \\
 &= \frac{1}{N^2} \sum_n \sum_{n'} [\gamma_{xx}^2(m) + \gamma_{xx}^2(n-n') \\
 &\quad + \gamma_{xx}^*(n'+m-n)\gamma_{xx}(n+m-n')]
 \end{aligned}$$

Let $p = n - n'$. Then

$$\begin{aligned}
 E[|\gamma_{xx}(m)|^2] &= \gamma_{xx}^2(m) \left[\frac{N-|m|}{N} \right]^2 + \frac{1}{N^2} \sum_n \sum_p [\gamma_{xx}^2(p)\gamma_{xx}^*(p-m)\gamma_{xx}(p+m)] \\
 &= |E[\gamma_{xx}(m)]|^2 + \frac{1}{N^2} \sum_n \sum_p [\gamma_{xx}^2(p)\gamma_{xx}^*(p-m)\gamma_{xx}(p+m)]
 \end{aligned}$$

Therefore,

$$\begin{aligned}
 \text{var}[\gamma_{xx}(m)] &= \frac{1}{N^2} \sum_n \sum_p [\gamma_{xx}^2(p)\gamma_{xx}^*(p-m)\gamma_{xx}(p+m)] \\
 &\approx \frac{1}{N} \sum_{p=-\infty}^{\infty} [\gamma_{xx}^2(p)\gamma_{xx}^*(p-m)\gamma_{xx}(p+m)]
 \end{aligned}$$

12.3

(a)

$$\begin{aligned}
 E[\gamma_{xx}(m)\gamma_{xx}^*(m')] &= E \left\{ \left[\frac{1}{N} \sum_{n=0}^{N-|m|-1} x^*(n)x(n+m) \right] \right. \\
 &\quad \left. \left[\frac{1}{N} \sum_{n'=0}^{N-|m'|-1} x(n')x^*(n'+m') \right] \right\} \\
 &= \frac{1}{N^2} \sum_n \sum_{n'} E\{x^*(n)x(n+m)x(n')x^*(n'+m')\} \\
 &= \frac{1}{N^2} \sum_n \sum_{n'} \{E[x^*(n)x(n+m)]E[x(n')x^*(n'+m')] \\
 &\quad + E[x^*(n)x(n')]E[x^*(n'+m')x(n+m)] \\
 &\quad + E[x^*(n)x^*(n'+m')]E[x(n')x(n+m)]\} \\
 &= \frac{\sigma_x^4}{N^2} \sum_n \sum_{n'} [\delta(m)\delta(m') + \delta(n-n')\delta(m-m') \\
 &\quad + \delta(n'+m'-n)\delta(n+m-n')]
 \end{aligned}$$

$$\text{Hence, } E[p_{xx}(f_1)p_{xx}(f_2)] = \sum_{m=-(N-1)}^{N-1} \sum_{m'=-(N-1)}^{N-1} E[\gamma_{xx}(m)\gamma_{xx}^*(m')]e^{-j2\pi mf_1}e^{-j2\pi m'f_2}$$

$$\begin{aligned}
&= \frac{\sigma_x^4}{N^2} \sum_m \sum_{m'} \sum_n \sum_{n'} [\delta(m)\delta(m') + \delta(n-n')\delta(m-m') \\
&\quad + \delta(n'+m'-n)\delta(n+m-n')] e^{-j2\pi m f_1} e^{-j2\pi m' f_2} \\
&= \sigma_x^4 \left\{ 1 + \left[\frac{\sin \pi (f_1 + f_2) N}{N \sin \pi (f_1 + f_2)} \right]^2 + \left[\frac{\sin \pi (f_1 - f_2) N}{N \sin \pi (f_1 - f_2)} \right]^2 \right\}
\end{aligned}$$

(b)

$$\begin{aligned}
\text{cov}[p_{xx}(f_1)p_{xx}(f_2)] &= E[p_{xx}(f_1)p_{xx}(f_2)] - E[p_{xx}(f_1)]E[p_{xx}(f_2)] \\
&= E[p_{xx}(f_1)p_{xx}(f_2)] - \sigma_x^4 \\
&= \sigma_x^4 \left\{ \left[\frac{\sin \pi (f_1 + f_2) N}{N \sin \pi (f_1 + f_2)} \right]^2 + \left[\frac{\sin \pi (f_1 - f_2) N}{N \sin \pi (f_1 - f_2)} \right]^2 \right\}
\end{aligned}$$

(c)

$$\begin{aligned}
\text{var}[p_{xx}(f)] &= \text{cov}[p_{xx}(f_1)p_{xx}(f_2)]|_{f_1=f_2=f} \\
&= \sigma_x^4 \left[1 + \left(\frac{\sin 2\pi f N}{N \sin 2\pi f} \right)^2 \right]
\end{aligned}$$

12.4

Assume that $x(n)$ is the output of a linear system excited by white noise input $w(n)$, where $\sigma_x^2 = 1$. Then $p_{xx}(f) = \Gamma_{xx}(f)p_{ww}(f)$. From prob. 12.3, (a), (b) and (c), we have

$$\begin{aligned}
E[p_{xx}(f_1)p_{xx}(f_2)] &= \Gamma_{xx}(f_1)\Gamma_{xx}(f_2)E[p_{ww}(f_1)p_{ww}(f_2)] \\
&= \Gamma_{xx}(f_1)\Gamma_{xx}(f_2) \left\{ 1 + \left[\frac{\sin \pi (f_1 + f_2) N}{N \sin \pi (f_1 + f_2)} \right]^2 + \left[\frac{\sin \pi (f_1 - f_2) N}{N \sin \pi (f_1 - f_2)} \right]^2 \right\} \\
\text{cov}[p_{xx}(f_1)p_{xx}(f_2)] &= \Gamma_{xx}(f_1)\Gamma_{xx}(f_2)\text{cov}[p_{ww}(f_1)p_{ww}(f_2)] \\
&= \Gamma_{xx}(f_1)\Gamma_{xx}(f_2) \left\{ \left[\frac{\sin \pi (f_1 + f_2) N}{N \sin \pi (f_1 + f_2)} \right]^2 + \left[\frac{\sin \pi (f_1 - f_2) N}{N \sin \pi (f_1 - f_2)} \right]^2 \right\} \\
\text{var}[p_{xx}(f)] &= \text{cov}[p_{xx}(f_1)p_{xx}(f_2)]|_{f_1=f_2=f} \\
&= \Gamma_{xx}^2 \left[1 + \left(\frac{\sin 2\pi f N}{N \sin 2\pi f} \right)^2 \right]
\end{aligned}$$

12.5

$$\begin{aligned}
\text{Let } y_k(n) &= x(n) * h_k(n) \\
&= \sum_{m=0}^{N-1} x(m) e^{\frac{j2\pi k(n-m)}{N}} \\
&= e^{\frac{j2\pi k n}{N}} \sum_{m=0}^{N-1} x(m) e^{-\frac{j2\pi k m}{N}} \\
y_k(n)|_{n=N} &= \sum_{m=0}^{N-1} x(m) e^{-\frac{j2\pi k m}{N}} \\
&= X(k)
\end{aligned}$$

Note that this is just the Goertzel algorithm for computing the DFT. Then,

$$|y_k(n)|^2 = |X(k)|^2 = \left| \sum_{m=0}^{N-1} x(m) e^{-j2\pi km} \right|^2$$

12.6

From (12.2.18) we have

$$\begin{aligned} W(f) &= \frac{1}{MU} \left| \sum_{n=0}^{M-1} w(n) e^{-j2\pi fn} \right|^2 \\ &= \frac{1}{MU} \sum_{n=0}^{M-1} \sum_{n'=0}^{M-1} w(n) w^*(n') e^{-j2\pi f(n-n')} \\ \int_{-\frac{1}{2}}^{\frac{1}{2}} W(f) df &= \frac{1}{MU} \sum_n \sum_{n'} w(n) w^*(n') \int_{-\frac{1}{2}}^{\frac{1}{2}} e^{-j2\pi f(n-n')} df \\ &= \frac{1}{MU} \sum_n \sum_{n'} w(n) w^*(n') \delta(n-n') \\ &= \frac{1}{U} \left[\frac{1}{M} \sum_{n=0}^{M-1} |w(n)|^2 \right] = 1 \end{aligned}$$

by the definition of U in (12.2.12)

12.7

- (a) (1) Divide $x(n)$ into subsequences of length $\frac{M}{2}$ and overlapped by 50% to produce $4k$ subsequences. Each subsequence is padded with $\frac{M}{2}$ zeros.
 (2) Compute the M-point DFT of each frame or subsequence.
 (3) Compute the magnitude square of each DFT.
 (4) Average the $4k$ M-point DFT's.
 (5) Perform the IDFT to obtain an estimate of the autocorrelation sequence.
- (b)

$$\begin{aligned} X_3(k) &= \sum_{m=0}^{M-1} x_3(m) e^{-j2\pi km} \\ &= \sum_{m=0}^{\frac{M}{2}-1} x_1(m) e^{-j2\pi km} + \sum_{m=\frac{M}{2}}^{M-1} x_2(m - \frac{M}{2}) e^{-j2\pi km} \\ &= \sum_{m=0}^{M-1} x_1(m) e^{-j2\pi km} + e^{-j\pi k} \sum_{m'=0}^{M-1} x_2(m') e^{-j2\pi km'} \\ X_3(k) &= X_1(k) + e^{-j\pi k} X_2(k) \end{aligned}$$

- (c) Instead of zero-padding, we can combine two subsequences to produce a single M-point subsequence and thus reduce the number of sequences from $4k$ to $2k$. Then, we use the relation in (b) for the DFT.

12.8

(a) Obviously, $\Delta f = 0.01$. From (12.2.52), $M = \frac{0.9}{\Delta f} = 90$.

(b) From (12.2.53), the quality factor is $Q_B = 1.1N\Delta f$. This expression does not depend on M ; hence, there is no advantage to increasing the value of M beyond 90.

12.9

(a) From table 12.1, we have

$$\begin{aligned} Q_B &= 1.11N\Delta f \\ \Rightarrow \Delta f &= \frac{Q_B}{1.11N} = \frac{1}{111} \\ Q_w &= 1.39N\Delta f \\ \Rightarrow \Delta f &= \frac{Q_w}{1.39N} = \frac{1}{139} \\ Q_{BT} &= 2.34N\Delta f \\ \Rightarrow \Delta f &= \frac{Q_{BT}}{2.34N} = \frac{1}{234} \end{aligned}$$

(b)

For the Bartlett estimate,

$$\begin{aligned} Q_B &= \frac{N}{M} \\ \Rightarrow M &= \frac{N}{Q_B} = 100 \end{aligned}$$

For the Welch estimate with 50% overlap,

$$\begin{aligned} Q_w &= \frac{16N}{M} \\ \Rightarrow M &= \frac{16N}{Q_w} = 178 \end{aligned}$$

For the Blackman-Tukey estimate,

$$\begin{aligned} Q_{BT} &= \frac{1.5N}{M} \\ \Rightarrow M &= \frac{1.5N}{Q_{BT}} = 150 \end{aligned}$$

12.10

(a) Suppose $P_B^{(i)}(f)$ is the periodogram based on the Bartlett method. Then,

$$\begin{aligned} P_B^{(i)}(f) &= \frac{1}{M} \left| \sum_{n=0}^{M-1} x_i(n) e^{-j2\pi f n} \right|^2, \quad i = 0, 1, \dots, k-1 \\ P_{xx}^{(0)}(f) &= 0 \\ P_{xx}^{(1)}(f) &= \frac{1-w}{M} \left| \sum_{n=0}^{M-1} x_1(n) e^{-j2\pi f n} \right|^2 \\ &= (1-w)P_B^{(1)}(f) \\ P_{xx}^{(2)}(f) &= wP_{xx}^{(1)}(f) + (1-w)P_B^{(1)}(f) \end{aligned}$$

$$\begin{aligned}
&= (1-w)[wP_B^{(1)}(f) + P_B^{(2)}(f)] \\
P_{xx}^{(m)}(f) &= (1-w) \sum_{k=1}^m m w^{m-k} P_B^{(k)}(f) \\
\text{Therefore, } E\{P_{xx}^{(M)}(f)\} &= (1-w) \sum_{k=1}^M M w^{M-k} E\{P_B^{(k)}(f)\} \\
&= (1-w) \frac{1-w^M}{1-w} \frac{1}{M} \int_{-\frac{1}{2}}^{\frac{1}{2}} \Gamma_{xx}(\alpha) \left[\frac{\sin \pi(f-\alpha)M}{\sin \pi(f-\alpha)} \right]^2 d\alpha \\
&= (1-w^M) \frac{1}{M} \int_{-\frac{1}{2}}^{\frac{1}{2}} \Gamma_{xx}(\alpha) \left[\frac{\sin \pi(f-\alpha)M}{\sin \pi(f-\alpha)} \right]^2 d\alpha \\
\text{var}\{P_{xx}^{(M)}(f)\} &= E\{[P_{xx}^{(M)}(f)]^2\} - [E\{P_{xx}^{(M)}(f)\}]^2 \\
\text{var}\{P_{xx}^{(M)}(f)\} &= E\left\{ \left[(1-w) \sum_{k=1}^M M w^{M-k} P_B^{(k)}(f) \right]^2 \right\} \\
&\quad - \left\{ E\left[(1-w) \sum_{k=1}^M M w^{M-k} P_B^{(k)}(f) \right] \right\}^2 \\
&= (1-w)^2 \left[\sum_{k=1}^M M w^{2(M-k)} E\{P_B^{(k)}(f)\}^2 - \{E\{P_B^{(k)}(f)\}\}^2 \right] \\
&= (1-w)^2 \sum_{k=1}^M M w^{2(M-k)} \text{var}\{P_B^{(k)}(f)\} \\
&= (1-w)^2 \frac{1-w^{2M}}{1-w^2} \Gamma_{xx}^2(f) \left[1 + \left(\frac{\sin 2\pi f M}{M \sin 2\pi f} \right)^2 \right] \\
&= (1-w^{2w}) \frac{1-w}{1+w} \Gamma_{xx}^2(f) \left[1 + \left(\frac{\sin 2\pi f M}{M \sin 2\pi f} \right)^2 \right]
\end{aligned}$$

(b)

$$\begin{aligned}
E\{P_{xx}^{(M)}(f)\} &= E\{P_{xx}^{(w)}(f)\} \\
&= \int_{-\frac{1}{2}}^{\frac{1}{2}} \Gamma_{xx}(\alpha) W(f-\alpha) d\alpha \\
\text{where } W(f) &= \frac{1}{MU} \left| \sum_{n=0}^{M-1} w(n) e^{-j2\pi f n} \right|^2 \\
\text{var}\{P_{xx}^{(M)}(f)\} &= (1-w)^2 \sum_{k=1}^M w^{2(M-k)} \text{var}\{\tilde{P}_{xx}^{(i)}(f)\} \\
&= (1-w^{2M}) \left(\frac{1-w}{1+w} \right) \Gamma_{xx}^2(f)
\end{aligned}$$

12.11

Let $R_{xx}^{(i)}$ be defined as follows:

$$R_{xx}^{(i)} = \frac{1}{M} \begin{bmatrix} r_{xx}^{(i)}(0) & r_{xx}^{(i)}(1) & \dots & & \\ r_{xx}^{(i)}(-1) & r_{xx}^{(i)}(0) & \dots & & \\ & & \ddots & & \\ & & & & r_{xx}^{(i)}(0) \end{bmatrix}$$

Then,

$$\begin{aligned}
E^{*t}(f)R_{xx}^{(i)}E(f) &= \sum_{k=0}^{M-1} \sum_{k'=0}^{M-1} \frac{1}{M} r_{xx}^{(i)}(k-k') e^{-j2\pi(k-k')f} \\
&= \frac{1}{M} \sum_{k=0}^{M-1} \sum_{m=k-(M-1)}^{M-1} r_{xx}^{(i)}(m) e^{-j2\pi mf} \\
&= \sum_{-(M-1)}^{(M-1)} \frac{(M|m|)}{M} r_{xx}^{(i)}(m) e^{-j2\pi mf} \\
&= P_{xx}^{(i)}(f)
\end{aligned}$$

$$\text{Therefore, } P_{xx}^{(B)}(f) = \frac{1}{K} \sum_{k=1}^K E^{*t}(f)R_{xx}^{(k)}E(f)$$

12.12

To prove the recursive relation in (12.3.19) we make use of the following relations:

$$\hat{E}_m = \sum_{n=m}^{N-1} [|f_m(n)|^2 + |g_m(n-1)|^2] e \quad (1)$$

$$\text{where } f_m(n) = f_{m-1}(n) + k_m g_{m-1}(n-1)$$

$$g_m(n) = k_m^* f_{m-1}(n) + g_{m-1}(n-1) \quad (2)$$

$$\begin{aligned}
\text{and } \hat{E}_{m-1} &= \sum_{n=m-1}^{N-1} [|f_{m-1}(n)|^2 + |g_{m-1}(n-1)|^2] \\
&= |f_{m-1}(m-1)|^2 + |g_{m-1}(m-2)|^2 \\
&\quad + \sum_{n=m}^{N-1} [|f_{m-1}(n)|^2 + |g_{m-1}(n-1)|^2]
\end{aligned}$$

$$\text{Also, } \sum_{n=m}^{N-1} [f_{m-1}(n) + g_{m-1}^*(n-1)] = -\frac{1}{2} k_m \hat{E}_{m-1}$$

We substitute for $f_m(n)$ and $g_m(n-1)$ from (2) into (1), and we expand the expressions. Then, use the relations for \hat{E}_{m-1} and k_m to reduce the result.

12.13

$$x(n) = \frac{1}{2}x(n-1) + w(n) - w(n-1)$$

$$E[x(n)] = \frac{1}{2}E[x(n-1)] + E[w(n)] - E[w(n-1)]$$

$$\text{since } E[w(n)] = 0, \text{ it follows that } E[x(n)] = 0$$

To determine the autocorrelation, we have

$$h(0) = \frac{1}{2}h(-1) + \delta(0) - \delta(-1) = -1$$

$$h(1) = \frac{1}{2}h(0) + \delta(1) - \delta(0) = -\frac{1}{2}$$

$$p = q = 1, \quad a = -\frac{1}{2}, \quad b_0 = 1, \quad b_1 = -1$$

$$\text{Hence, } \gamma_{xx}(0) = \frac{1}{2}\gamma_{xx}(1) + \sigma_w^2(1 + \frac{1}{2})$$

$$\gamma_{xx}(1) = \frac{1}{2}\gamma_{xx}(0) + \sigma_w^2(-1)$$

$$\text{and } \gamma_{xx}(0) = \frac{4}{3}\sigma_w^2$$

$$\gamma_{xx}(1) = -\frac{1}{3}\sigma_w^2$$

$$\begin{aligned} \gamma_{xx}(m) &= -a_1\gamma_{xx}(m-1) \\ &= -\frac{1}{3}\left(\frac{1}{2}\right)^{m-1}\sigma_w^2, \quad m > 1 \end{aligned}$$

$$\begin{aligned} \gamma_{xx}(m) &= \gamma_{xx}(-m) \\ &= -\frac{1}{3}\left(\frac{1}{2}\right)^{-m+1}\sigma_w^2, \quad m < 0 \end{aligned}$$

12.14

$$x(n) = w(n) - 2w(n-1) + w(n-2)$$

$$E[x(n)] = 0 \text{ since } E[w(n)] = 0$$

$$\gamma_{xx}(m) = \sigma_w^2 \sum_{k=0}^q b_k b_{k+m}, \quad 0 \leq m \leq q$$

$$\text{where } q = 2, \quad b_0 = 1, \quad b_1 = -2, \quad b_2 = 1$$

$$\text{Hence, } \gamma_{xx}(0) = \sigma_w^2 \sum_{k=0}^2 b_k^2 = b\sigma_w^2$$

$$\gamma_{xx}(1) = \sigma_w^2 \sum_{k=0}^2 b_k b_{k+1} = -4\sigma_w^2$$

$$\gamma_{xx}(2) = \sigma_w^2 \sum_{k=0}^2 b_k b_{k+2} = \sigma_w^2$$

$$\gamma_{xx}(m) = 0, \quad |m| \geq 3,$$

$$\gamma_{xx}(-m) = \gamma_{xx}(m)$$

12.15

(a)

$$\begin{aligned} \Gamma_{xx}(z) &= \sum_m \gamma_{xx}(m)z^{-m} \\ &= 2z^{-2}(z^4 - 2z^3 + 3z^2 - 2z + 1) \end{aligned}$$

The four zeros are $\frac{1 \pm j\sqrt{3}}{2}, \frac{1 \pm j\sqrt{3}}{2}$

The minimum-phase system is

$$H(z) = G(1 - z^{-1} + z^{-2}), \text{ where } G = \sqrt{2}$$

$$\text{Hence, } H(z) = \sqrt{2}(1 - z^{-1} + z^{-2})$$

(b) The solution is unique.

12.16

(a)

$$\begin{aligned}\Gamma_{xx}(z) &= \sum_{m=-\infty}^{\infty} \gamma_{xx}(m)z^{-m} \\ &= \frac{z^2}{62}(6 - 35z^{-1} + 62z^{-2} - 35z^{-3} + 6z^{-4}) \\ &= \frac{z^2}{62}(1 - 3z^{-1})(1 - 2z^{-1})(1 - \frac{1}{2}z^{-1})(1 - \frac{1}{3}z^{-1})\end{aligned}$$

$$\text{The four zeros are } z = 3, 2, \frac{1}{3}, \frac{1}{2}$$

$$\begin{aligned}\text{The minimum phase system is } H(z) &= \frac{6}{\sqrt{62}}(1 - \frac{1}{2}z^{-1})(1 - \frac{1}{3}z^{-1}) \\ &= \frac{1}{\sqrt{62}}(6 - 5z^{-1} + z^{-2})\end{aligned}$$

(b) The maximum phase system is $H(z) = \frac{1}{\sqrt{62}}(1 - 5z^{-1} + 6z^{-2})$

(c) There are two possible mixed-phase systems: $H_1(z) = \frac{1}{\sqrt{62}}(3 - 7z^{-1} + 2z^{-2})$ $H_2(z) = \frac{1}{\sqrt{62}}(2 - 7z^{-1} + 3z^{-2})$

12.17

(a)

$$\begin{aligned}H(z) &= \frac{1 + z^{-1}}{1 - 0.8z^{-1}} \\ \Gamma_{hh}(f) &= H(z)H(z^{-1})|_{z=e^{j2\pi f}} \\ &= \frac{1 + e^{-j2\pi f}}{1 - 0.8e^{-j2\pi f}} \frac{1 + e^{j2\pi f}}{1 - 0.8e^{j2\pi f}} \\ &= 4 \frac{\cos^2 \pi f}{1.64 - 1.6\cos 2\pi f} \\ \gamma_{xx}(m) &= \left(\frac{1}{2}\right)^{|m|} \\ \Rightarrow \Gamma_{xx}(f) &= \sum_{m=-\infty}^{\infty} \left(\frac{1}{2}\right)^{|m|} e^{-j2\pi f m} \\ &= \frac{0.75}{1.25 - \cos 2\pi f} \\ \Gamma_{yy}(f) &= \Gamma_{xx}(f)\Gamma_{hh}(f) \\ &= \frac{3\cos^2 \pi f}{(1.64 - 1.6\cos 2\pi f)(1.25 - \cos 2\pi f)}\end{aligned}$$

(b)

$$\begin{aligned}\Gamma_{yy}(f) &= \frac{54}{1.64 - 1.6\cos 2\pi f} - \frac{\frac{75}{2}}{1.25 - \cos 2\pi f} \\ &= 150 \frac{\frac{9}{25}}{1.64 - 1.6\cos 2\pi f} - 50 \frac{\frac{3}{4}}{1.25 - \cos 2\pi f} \\ \gamma_{yy}(m) &= 150(0.8)^{|m|} - 50\left(\frac{1}{2}\right)^{|m|}\end{aligned}$$

$$(c) \sigma_w^2 = \gamma_{xx}(0) = 150 - 50 = 100$$

12.18

proof is by contradiction.

(a) Assume the $|k_m| > 1$. Since $E_m = (1 - |k_m|^2)E_{m-1}$, this implies that either $E_m < 0$ or $E_{m-1} < 0$. Hence, $\sigma_w^2 < 0$, and

$$\underline{a}^t \Gamma_{xx} \underline{a} = \underline{a}^t \begin{bmatrix} \sigma_w^2 \\ 0 \\ \vdots \\ 0 \end{bmatrix} \Rightarrow \Gamma_{xx}$$

is not positive definite.

(b) From the Schur-Cohn test, $A_p(z)$ is stable if $|k_m| < 1$. Hence, the roots of $A_p(z)$ are inside the unit circle.

12.19

(a)

$$\begin{aligned} \hat{x}(n) &= -a_1 x(n-1) - a_2 x(n-2) - a_3 x(n-3) \\ \text{But } x(n) &= \frac{14}{24} x(n-1) + \frac{9}{24} x(n-2) - \frac{1}{24} x(n-3) + w(n) \end{aligned}$$

$E\{[x(n) - \hat{x}(n)]^2\}$ is minimized by selecting the coefficients as $a_1 = -\frac{14}{24}$, $a_2 = -\frac{9}{24}$, $a_3 = \frac{1}{24}$

(b)

$$\begin{aligned} \gamma_{xx}(m) &= -\sum_{k=1}^3 a_k \gamma_{xx}(m-k), \quad m > 0 \\ &= -\sum_{k=1}^3 a_k \gamma_{xx}(m-k) + \sigma_w^2, \quad m = 0 \end{aligned}$$

Since we know the $\{a_k\}$ we can solve for $\gamma_{xx}(m)$, $m = 0, 1, 2, 3$. Then we can obtain $\gamma_{xx}(m)$ for $m > 3$, by the above recursion. Thus,

$$\begin{aligned} \gamma_{xx}(0) &= 4.93 \\ \gamma_{xx}(1) &= 4.32 \\ \gamma_{xx}(2) &= 4.2 \\ \gamma_{xx}(3) &= 3.85 \\ \gamma_{xx}(4) &= 3.65 \\ \gamma_{xx}(5) &= 3.46 \end{aligned}$$

(c)

$$\begin{aligned} A_3(z) &= 1 - \frac{14}{24}z^{-1} - \frac{9}{24}z^{-2} + \frac{1}{24}z^{-3} \\ k_3 &= \frac{1}{24} \\ B_3(z) &= \frac{1}{24} - \frac{9}{24}z^{-1} - \frac{14}{24}z^{-2} + z^{-3} \end{aligned}$$

$$\begin{aligned}
A_2(z) &= \frac{A_3(z) - k_3 B_3(z)}{1 - k_3^2} \\
&= 1 - 0.569z^{-1} - 0.351z^{-2} \\
k_2 &= -0.351 \\
B_2(z) &= -0.351 - 0.569z^{-1} + z^{-2} \\
A_1(z) &= \frac{A_2(z) - k_2 B_2(z)}{1 - k_2^2} \\
&= 1 - 0.877z^{-1} \\
k_1 &= -0.877
\end{aligned}$$

12.20

(a)

$$\begin{bmatrix} \gamma_{xx}(0) & \gamma_{xx}(1) & \gamma_{xx}(2) \\ \gamma_{xx}(-1) & \gamma_{xx}(0) & \gamma_{xx}(1) \\ \gamma_{xx}(-2) & \gamma_{xx}(-1) & \gamma_{xx}(0) \end{bmatrix} \begin{bmatrix} 1 \\ 0 \\ -0.81 \end{bmatrix} = \begin{bmatrix} \sigma_w^2 \\ 0 \\ 0 \end{bmatrix}$$

$$\gamma_{xx}(m) = 0.81\gamma_{xx}(m-2), \quad m \geq 3$$

$$\text{Hence, } \frac{\gamma_{xx}(m)}{\sigma_w^2} = \{2.91, 0, 2.36, 0, 1.91, 0, 1.55, 0, \dots\}$$

The values of the parameters $d_m = \sum_{k=0}^g b_k b_{k+m}$ are as follows:

$$MA(2) : d_m = \{2.91, 0, 2, 36\}$$

$$MA(4) : d_m = \{2.91, 0, 2, 36, 0, 1.91\}$$

$$MA(8) : d_m = \{2.91, 0, 2, 36, 0, 1.91, 0, 1.55, 0\}$$

(b) The $MA(2)$, $MA(4)$ and $MA(8)$ models have spectra that contain negative values. On the other hand, the spectrum of the AR process is shown below. Clearly, the MA models do not provide good approximations to the AR process. Refer to fig 12.1.

12.21

$$\gamma_{xx}(m) = \{1.656\sigma_w^2, 0, 0.81\sigma_w^2, 0, \dots\}.$$

For AR(2) process:

$$\begin{bmatrix} 1.656\sigma_w^2 & 0 & 0.81\sigma_w^2 \\ 0 & 1.656\sigma_w^2 & 0 \\ 0.81\sigma_w^2 & 0 & 1.656\sigma_w^2 \end{bmatrix} \begin{bmatrix} 1 \\ a_1 \\ a_2 \end{bmatrix} = \begin{bmatrix} g\sigma_w^2 \\ 0 \\ 0 \end{bmatrix}$$

The solution is

$$g = 1.12$$

$$a_1 = 0$$

$$a_2 = -0.489$$

For the AR(4) process, we obtain $g = 1.07$ and

$$\underline{a} = \{1, 0, -0.643, 0, 0.314\}$$

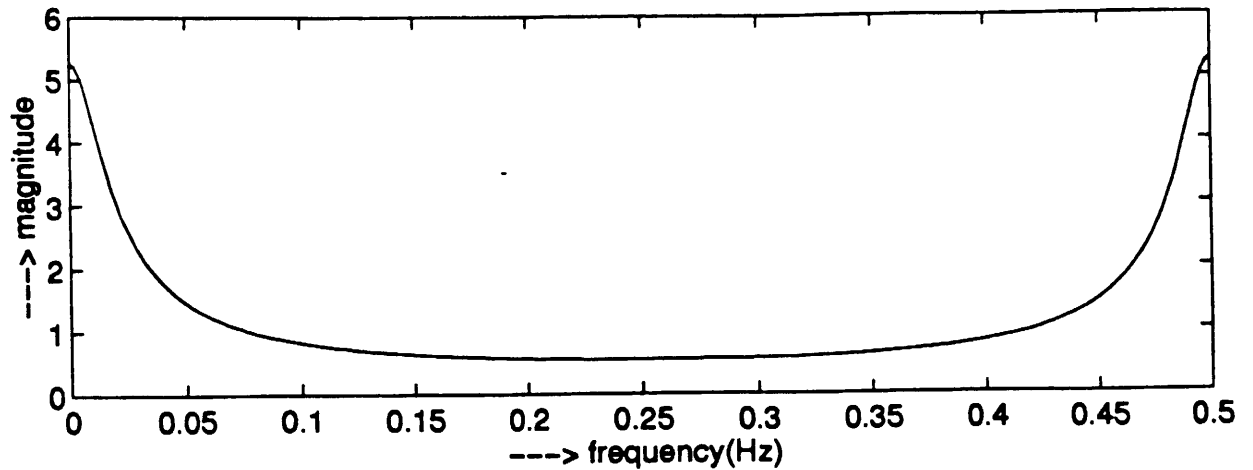

Figure 12.1:

For the AR(8) process, we obtain $g = 1.024$ and
 $\underline{a} = \{1, 0, -0.75, 0, 0.536, 0, -0.345, 0, 0.169\}$

Refer to fig 12.2.

12.22

(a)

$$\begin{aligned}\Gamma_{xx}(z) &= \frac{4\sigma_w^2 (2 - z^{-1})(2 - z)}{9 (3 - z^{-1})(3 - z)} \\ &= \sigma_w^2 H(z)H(z^{-1})\end{aligned}$$

The minimum-phase system function $H(z)$ is

$$\begin{aligned}H(z) &= \frac{2}{3} \frac{2 - z^{-1}}{3 - z^{-1}} \\ &= \frac{4}{9} \frac{1 - \frac{1}{2}z^{-1}}{1 - \frac{1}{3}z^{-1}}\end{aligned}$$

(b) The mixed-phase stable system has a system function

$$\begin{aligned}H(z) &= \frac{2}{3} \frac{1 - 2z^{-1}}{3 - z^{-1}} \\ &= \frac{2}{9} \frac{1 - 2z^{-1}}{1 - \frac{1}{3}z^{-1}}\end{aligned}$$

12.23

(a)

$$A_2(z) = 1 - 2r\cos\Theta z^{-1} + r^2 z^{-2}$$

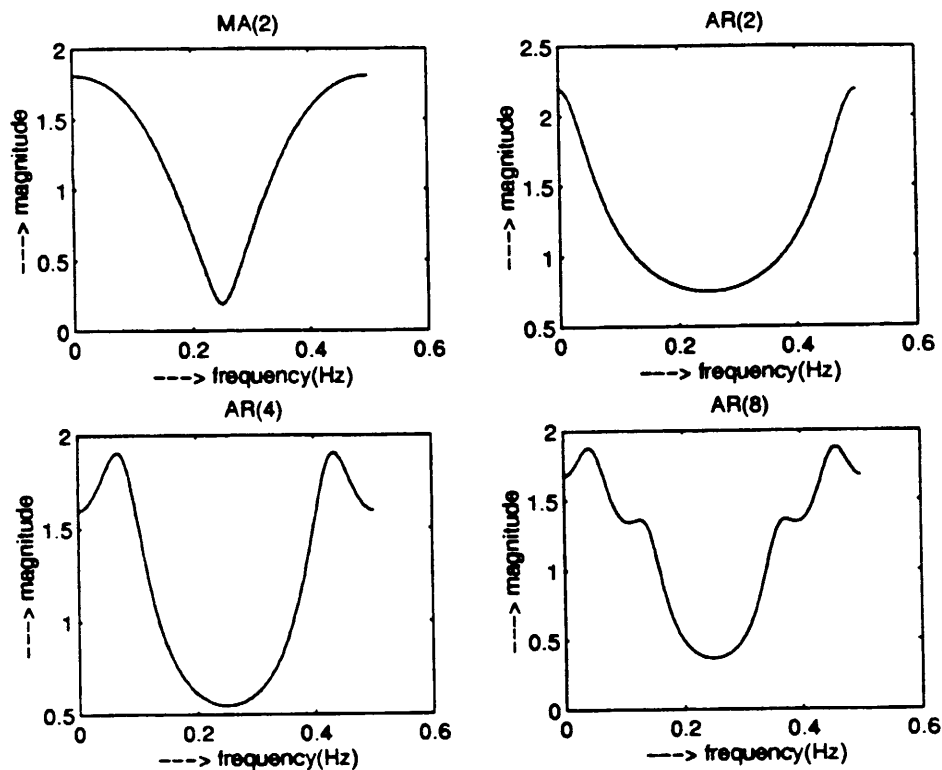

Figure 12.2:

$$\begin{aligned} \Rightarrow k_2 &= r^2 \\ B_2(z) &= r^2 - 2r\cos\Theta z^{-1} + z^{-2} \\ A_1(z) &= \frac{A_2(z) - k_2 B_2(z)}{1 - k_2^2} \\ &= 1 - \frac{2r\cos\Theta}{1 + r^2} z^{-1} \\ \text{Hence, } k_1 &= -\frac{2r\cos\Theta}{1 + r^2} \end{aligned}$$

(b) As $r \rightarrow 1$, $k_2 \rightarrow 1$ and $k_1 \rightarrow -\cos\Theta$

12.24

(a)

$$\begin{aligned} a_1(1) &= -1.25, a_2(2) = 1.25, a_3(3) = -1 \\ \text{Hence, } A_3(z) &= 1 - 1.25z^{-1} + 1.25z^{-2} - z^{-3} \end{aligned}$$

First, we determine the reflection coefficients. Clearly, $k_3 = -1$, which implies that the roots of $A_3(z)$ are on the unit circle. We may factor out one root. Thus,

$$\begin{aligned} A_3(z) &= (1 - z^{-1})(1 - \frac{1}{4}z^{-1} + z^{-2}) \\ &= (1 - z^{-1})(1 - \alpha z^{-1})(1 - \alpha^* z^{-1}) \\ \text{where } \alpha &= \frac{1 + j\sqrt{63}}{8} \end{aligned}$$

Hence, the roots of $A_3(z)$ are $z = 1, \alpha$, and α^* .
 (b) The autocorrelation function satisfies the equations

$$\gamma_{xx}(m) + \sum_{k=1}^3 a_3(k)\gamma_{xx}(m-k) = \begin{cases} \sigma_w^2, & m=0 \\ 0, & 1 \leq m \leq 3 \end{cases}$$

$$\begin{bmatrix} \gamma_{xx}(0) & \gamma_{xx}(1) & \gamma_{xx}(2) & \gamma_{xx}(3) \\ \gamma_{xx}(1) & \gamma_{xx}(0) & \gamma_{xx}(1) & \gamma_{xx}(2) \\ \gamma_{xx}(2) & \gamma_{xx}(1) & \gamma_{xx}(0) & \gamma_{xx}(1) \\ \gamma_{xx}(3) & \gamma_{xx}(2) & \gamma_{xx}(1) & \gamma_{xx}(0) \end{bmatrix} \begin{bmatrix} 1 \\ -1.25 \\ 1.25 \\ -1 \end{bmatrix} = \begin{bmatrix} \sigma_w^2 \\ 0 \\ 0 \\ 0 \end{bmatrix}$$

(c) Note that since $k_3 = -1$, the recursion $E_m^f = E_{m-1}^f(1 - |k_m|^2)$ implies that $E_3^f = 0$. This implies that the 4x4 correlation matrix Γ_{xx} is singular. Since $E_3^f = 0$, then $\sigma_w^2 = 0$

12.25

$$\begin{aligned} \gamma_{xx}(0) &= 1 \\ \gamma_{xx}(1) &= -0.5 \\ \gamma_{xx}(2) &= 0.625 \\ \gamma_{xx}(3) &= -0.6875 \end{aligned}$$

Use the Levinson-Durbin algorithm

$$a_1(1) = -\frac{\gamma_{xx}(1)}{\gamma_{xx}(0)} = \frac{1}{2}$$

$$A_1(z) = 1 + \frac{1}{2}z^{-1}$$

$$\Rightarrow k_1 = \frac{1}{2}$$

$$E_1 = (1 - a_1^2(1))\gamma_{xx}(0) = \frac{3}{4}$$

$$a_2(2) = -\frac{\gamma_{xx}(2) + a_1(1)\gamma_{xx}(1)}{E_1} = -\frac{1}{2}$$

$$a_2(1) = a_1(1) + a_2(2)a_1(1) = \frac{1}{4}$$

$$\text{Therefore, } A_2(z) = 1 + \frac{1}{4}z^{-1} - \frac{1}{2}z^{-2}$$

$$\Rightarrow k_2 = -\frac{1}{2}$$

$$E_2 = (1 - a_2^2(2))E_1 = \frac{9}{16}$$

$$a_3(3) = -\frac{\gamma_{xx}(3) + a_2(1)\gamma_{xx}(2) + a_2(2)\gamma_{xx}(1)}{E_2} = \frac{1}{2}$$

$$a_3(2) = a_2(2) + a_3(3)a_2(1) = -\frac{3}{8}$$

$$a_3(1) = a_2(1) + a_3(3)a_2(2) = 0$$

$$\text{Therefore, } A_3(z) = 1 - \frac{3}{8}z^{-2} + \frac{1}{2}z^{-3}$$

$$\Rightarrow k_3 = \frac{1}{2}$$

$$E_3 = (1 - a_3^2(3))E_2 = \frac{27}{64}$$

12.26

(a) (1)

$$\begin{aligned} H(w) &= \frac{1 - e^{-jw}}{1 + 0.81e^{-jw}} \\ \Gamma_{xx}(w) &= |H(w)|^2 \sigma_w^2 \\ \Gamma_{xx}(w) &= \left| \frac{1 - e^{-jw}}{1 + 0.81e^{-jw}} \right|^2 \sigma_w^2 \end{aligned}$$

(2)

$$\begin{aligned} H(w) &= (1 - e^{-j2w}) \\ \Gamma_{xx}(w) &= |H(w)|^2 \sigma_w^2 \\ &= 4\sigma_w^2 \sin^2 w \end{aligned}$$

(3)

$$\begin{aligned} H(w) &= \frac{1}{1 - 0.81e^{-jw}} \\ \Gamma_{xx}(w) &= \frac{\sigma_w^2}{1.6561 - 1.62\cos w} \end{aligned}$$

(b) Refer to fig 12.3.

(c) For (2),

$$\gamma_{xx}(m) = \begin{cases} \sigma_w^2 \sum_{k=0}^3 b_k b_{k+m}, & 0 \leq m \leq 2 \\ 0, & m > 2 \\ \gamma_{xx}^*(-m), & m < 0 \end{cases}$$

since $b_0 = 1$, $b_1 = 0$ and $b_2 = -1$, we have

$$\begin{aligned} \gamma_{xx}(0) &= 2\sigma_w^2 \\ \gamma_{xx}(2) &= -\sigma_w^2 \\ \gamma_{xx}(-2) &= -\sigma_w^2 \\ \gamma_{xx}(m) &= 0, \quad m \neq 0, \pm 2 \end{aligned}$$

For (3), the AR process has coefficients $a_0 = 1$, $a_1 = 0$ and $a_2 = 0.81$.

$$\begin{bmatrix} 1 & 0 & 0.81 \\ 0 & 1.81 & 0 \\ 0.81 & 0 & 1 \end{bmatrix} \begin{bmatrix} \gamma_{xx}(0) \\ \gamma_{xx}(1) \\ \gamma_{xx}(2) \end{bmatrix} = \begin{bmatrix} \sigma_w^2 \\ 0 \\ 0 \end{bmatrix}$$

$$\begin{aligned} \gamma_{xx}(0) &= 2.9\sigma_w^2 \\ \gamma_{xx}(m) &= 0, \quad m \text{ odd} \\ \gamma_{xx}(m) &= 2.9(0.9)^{|m|}\sigma_w^2, \quad m \text{ even} \end{aligned}$$

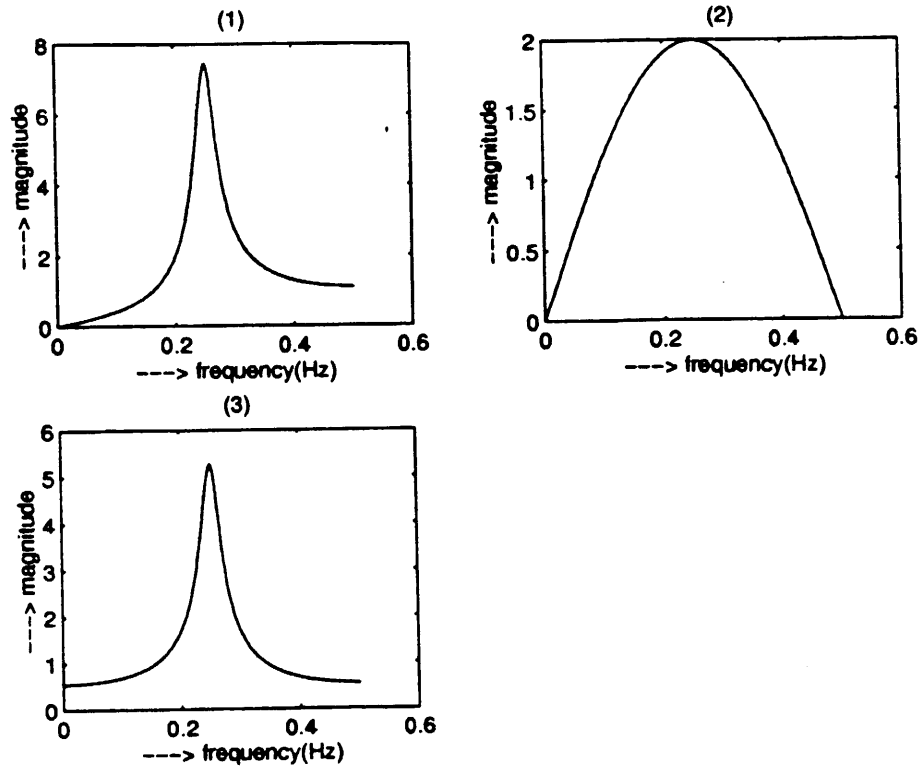

Figure 12.3:

12.27

(a)

$$\begin{aligned}
 \Gamma_{xx}(z) &= \sum_{-\infty}^{\infty} \gamma_{xx}(m) z^{-m} \\
 &= \sum_{-\infty}^{-1} \left(\frac{1}{4}\right)^{-m} z^{-m} + \sum_0^{\infty} \left(\frac{1}{4}\right)^m z^{-m} \\
 &= \frac{\frac{1}{4}z}{1 - \frac{1}{4}z} + \frac{1}{1 - \frac{1}{4}z^{-1}} \\
 &= \frac{\frac{15}{16}}{(1 - \frac{1}{4}z)(1 - \frac{1}{4}z^{-1})} \\
 \text{since } \Gamma_{xx}(z) &= \sigma^2 H(z)H(z^{-1}), \\
 H(z) &= \frac{0.968}{1 - \frac{1}{4}z^{-1}}
 \end{aligned}$$

is the minimum-phase solution. The difference equation is

$$x(n) = \frac{1}{4}x(n-1) + 0.968w(n)$$

where $w(n)$ is a white noise sequence with zero mean and unit variance.
 (b) If we choose

$$\begin{aligned} H(z) &= \frac{1}{1 - \frac{1}{4}z} \\ &= \frac{z^{-1}}{z^{-1} - \frac{1}{4}} \\ &= -\frac{4z^{-1}}{1 - 4z^{-1}} \end{aligned}$$

then, $x(n) = 4x(n-1) - 4x0.968w(n-1)$

12.28

$$\begin{aligned} \gamma_{xx}(0) &= 1 \\ \gamma_{xx}(1) &= 0 \\ \gamma_{xx}(2) &= -a^2 \\ \gamma_{xx}(3) &= 0 \\ a_1(1) &= -\frac{\gamma_{xx}(1)}{\gamma_{xx}(0)} = 0 \\ A_1(z) &= 1 \\ \Rightarrow k_1 &= 0 \\ E_1 &= (1 - a_1^2(1))\gamma_{xx}(0) = 1 \\ a_2(2) &= -\frac{\gamma_{xx}(2) + a_1(1)\gamma_{xx}(1)}{E_1} = a^2 \\ a_2(1) &= a_1(1) + a_2(2)a_1(1) = 0 \\ \text{Therefore, } A_2(z) &= 1 + a^2z^{-2} \\ \Rightarrow k_2 &= a^2 \\ E_2 &= (1 - a_2^2(2))E_1 = 1 - a^4 \\ a_3(3) &= -\frac{\gamma_{xx}(3) + a_2(1)\gamma_{xx}(2) + a_2(2)\gamma_{xx}(1)}{E_2} = 0 \\ a_3(2) &= a_2(2) + a_3(3)a_2(1) = a^2 \\ a_3(1) &= a_2(1) + a_3(3)a_2(2) = 0 \\ \text{Therefore, } A_3(z) = A_2(z) &= 1 + a^2z^{-2} \\ \Rightarrow k_3 &= 0 \\ E_3 = E_2 &= 1 - a^4 \end{aligned}$$

12.29

(a) For the Bartlett estimate,

$$\begin{aligned} M &= \frac{0.9}{\Delta f} \\ &= \frac{0.9}{0.01} = 90 \\ (b) M &= \frac{0.9}{0.02} = 45 \end{aligned}$$

$$\begin{aligned}
\text{(c) for (a), } Q_B &= \frac{N}{M} \\
&= \frac{2400}{90} = 26.67 \\
\text{for (b), } Q_B &= \frac{N}{M} \\
&= \frac{2400}{45} = 53.33
\end{aligned}$$

12.30

$$A_p(z) = A_{p-1}(z) + k_p B_{p-1}(z)z^{-1}$$

where $B_{p-1}(z)$ is the reverse polynomial of $A_{p-1}(z)$.

For $|k_p| < 1$, we have all the roots inside the unit circle as previously shown.

For $|k_p| = 1$, $A_p(z)$ is symmetric, which implies that all the roots are on the unit circle.

For $|k_p| > 1$, $A_p(z) = A_s(z) + \epsilon B_{p-1}(z)z^{-1}$, where $A_s(z)$ is the symmetric polynomial with all the roots on the unit circle and $B_{p-1}(z)$ has all the roots outside the unit circle. Therefore, $A_p(z)$ will have all its roots outside the unit circle.

12.31

$$\Gamma_{xx}(f) = \sigma_w^2 \frac{|e^{j2\pi f} - 0.9|^2}{|e^{j2\pi f} - j0.9|^2 |e^{j2\pi f} + j0.9|^2}$$

(a)

$$\Gamma_{xx}(z) = \sigma_w^2 \frac{z - 0.9}{z^2 + 0.81} \frac{z^{-1} - 0.9}{z^{-2} + 0.81}$$

$$\begin{aligned}
\text{Therefore, } H(z) &= \frac{z - 0.9}{z^2 + 0.81} \\
&= \frac{z^{-1}(1 - 0.9z^{-1})}{1 + 0.81z^{-2}}
\end{aligned}$$

(b) The inverse system is

$$\frac{1}{H(z)} = \frac{1 + 0.81z^{-2}}{z^{-1}(1 - 0.9z^{-1})}$$

This is a stable system.

12.32

$$X(k) = \sum_{n=0}^{N-1} x(n) e^{-\frac{j2\pi nk}{N}}$$

(a)

$$\begin{aligned}
E[X(k)] &= \sum_n E[x(n)] e^{-\frac{j2\pi nk}{N}} = 0 \\
E[|X(k)|^2] &= \sum_n \sum_m E[x(n)x^*(m)] e^{-\frac{j2\pi k(n-m)}{N}} \\
&= \sum_n \sum_m \sigma_x^2 \delta(n-m) e^{-\frac{j2\pi k(n-m)}{N}}
\end{aligned}$$

$$\begin{aligned}
&= \sigma_x^2 \sum_{n=0}^{N-1} 1 \\
&= N\sigma_x^2
\end{aligned}$$

(b)

$$\begin{aligned}
E\{X(k)X^*(k-m)\} &= \sum_n \sum_{n'} E[x(n)x^*(n')] e^{-j2\pi kn} e^{j2\pi n'(k-m)} \\
&= \sigma_x^2 \sum_n \sum_{n'} \delta(n-n') e^{-j2\pi mn'} e^{-j2\pi k(n-n')} \\
&= \sigma_x^2 e^{j2\pi mn} \\
&= N\sigma_x^2, \quad m = pN \\
&= 0, \quad \text{otherwise } p = 0, \pm 1, \pm 2, \dots
\end{aligned}$$

12.33

$$\begin{aligned}
\gamma_{vv}(m) &= E[v^*(n)v(n+m)] \\
&= \sum_{k'=0}^q \sum_{k=0}^q b_k^* b_{k'} E[w^*(n-k)w(n+m-k')] \\
&= \sigma_w^2 \sum_{k'=0}^q \sum_{k=0}^q b_k^* b_{k'} \delta(m+k-k') \\
&= \sigma_w^2 \sum_{k=0}^q b_k^* b_{k+m} \\
&= \sigma_w^2 d_m
\end{aligned}$$

$$\text{Then, } \Gamma_{vv}(f) = \sigma_w^2 \sum_{m=-q}^q d_m e^{-j2\pi f m}$$

12.34

$$\begin{aligned}
\gamma_{xx}(m) &= E[x^*(n)x(n+m)] \\
&= A^2 E\{\cos(w_1 n + \phi)\cos[w_1(n+m) + \phi]\} \\
&= \frac{A^2}{2} E\{\cos w_1 m + \cos[w_1(2n+m) + 2\phi]\} \\
&= \frac{A^2}{2} \cos w_1 n
\end{aligned}$$

12.35

(a)

$$\begin{aligned}
x(n) &= 0.81x(n-2) + w(n) \\
y(n) &= x(n) + v(n) \\
\Rightarrow x(n) &= y(n) - v(n) \\
y(n) - v(n) &= 0.81y(n-2) - 0.81v(n-2) + w(n)
\end{aligned}$$

Therefore, $y(n) = 0.81y(n-2) + v(n) - 0.81v(n-2) + w(n)$
so that $y(n)$ is an ARMA(2,2) process

(b)

$$\begin{aligned}x(n) &= -\sum_{k=1}^p a_k x(n-k) + w(n) \\y(n) &= x(n) + v(n) \\ \Rightarrow x(n) &= y(n) - v(n) \\y(n) - v(n) &= -\sum_{k=1}^p a_k [y(n-k) - v(n-k)] + w(n) \\y(n) + \sum_{k=1}^p a_k y(n-k) &= v(n) + \sum_{k=1}^p a_k v(n-k) + w(n)\end{aligned}$$

Hence, $y(n)$ is an ARMA(p,p) process

$$\text{Note that } X(z)[1 + \sum_{k=1}^p a_k z^{-k}] = W(z)$$

$$\begin{aligned}H(z) &= \frac{1}{1 + \sum_{k=1}^p a_k z^{-k}} \\ &= \frac{1}{A_p(z)} \\ \Gamma_{xx}(z) &= \sigma_w^2 H(z)H(z^{-1}) \\ \text{and } \Gamma_{yy}(z) &= \sigma_w^2 H(z)H(z^{-1}) + \sigma_v^2 \\ &= \frac{\sigma_w^2}{A_p(z)A_p(z^{-1})} + \sigma_v^2 \\ &= \frac{\sigma_w^2 + \sigma_v^2 A_p(z)A_p(z^{-1})}{A_p(z)A_p(z^{-1})}\end{aligned}$$

12.36

(a)

$$\begin{aligned}\gamma_{xx}(m) &= E\left\{\left[\sum_{k=1}^K A_k \cos(\omega_k n + \phi_k) + w(n)\right]\left[\sum_{k'=1}^K A_{k'} \cos(\omega_{k'}(n+m) + \phi_{k'}) + w(n+m)\right]\right\} \\ &= \sum_k \sum_{k'} A_k A_{k'} E\{\cos(\omega_k n + \phi_k) \cos(\omega_{k'}(n+m) + \phi_{k'})\} + E[w(n)w(n+m)] \\ &= \sum_{k=1}^K \frac{A_k^2}{2} \cos(\omega_k n) + \sigma_w^2 \delta(m)\end{aligned}$$

(b)

$$\begin{aligned}\Gamma_{xx}(w) &= \sum_{m=-\infty}^{\infty} \gamma_{xx}(m) e^{-j\omega m} \\ &= \sum_{k=1}^K \frac{A_k^2}{4} \sum_{m=-\infty}^{\infty} (e^{j\omega_k} + e^{-j\omega_k}) e^{-j\omega n} + \sigma_w^2\end{aligned}$$

$$\begin{aligned}
&= \sum_{k=1}^K \frac{A^2}{4} [2\pi\delta(\omega - \omega_k - 2\pi m) + 2\pi\delta(\omega + \omega_k - 2\pi m)] + \sigma_w^2 \\
&= \frac{\pi}{2} \sum_{k=1}^K A_k^2 [\delta(\omega - \omega_k - 2\pi m) + 2\pi\delta(\omega + \omega_k - 2\pi m)] + \sigma_w^2
\end{aligned}$$

12.37

$$\begin{aligned}
\mathcal{E} &= \underline{a}^{*T} \underline{\Gamma}_{yy} \underline{a} + \lambda(1 - \underline{a}^{*T} \underline{a}) \\
\frac{d\mathcal{E}}{d\underline{a}} &= 0 \\
\Rightarrow \underline{\Gamma}_{yy} \underline{a} - \lambda \underline{a} &= 0 \\
\text{or } \underline{\Gamma}_{yy} \underline{a} &= \lambda \underline{a}
\end{aligned}$$

Thus, \underline{a} is an eigenvector corresponding to the eigenvalue λ . Substitute $\underline{\Gamma}_{yy} \underline{a} = \lambda \underline{a}$ into \mathcal{E} . Then, $\mathcal{E} = \lambda$. To minimize \mathcal{E} , we select the smallest eigenvalue, namely, σ_w^2 .

12.38

(a)

$$\begin{aligned}
\gamma_{xx}(0) &= P + \sigma_w^2 \\
\gamma_{xx}(1) &= P \cos 2\pi f_1 \\
\gamma_{xx}(2) &= P \cos 4\pi f_1
\end{aligned}$$

By the Levinson-Durbin algorithm,

$$\begin{aligned}
a_1(1) &= -\frac{\gamma_{xx}(1)}{\gamma_{xx}(0)} \\
&= -\frac{P \cos 2\pi f_1}{P + \sigma_w^2} \\
k_1 &= a_1(1) \\
E_1 &= (1 - k_1^2) \gamma_{xx}(0) \\
&= \frac{P^2 \sin^2 2\pi f_1 + 2P\sigma_w^2 + \sigma_w^4}{P + \sigma_w^2} \\
a_2(2) &= -\frac{\gamma_{xx}(2) + a_1(1)\gamma_{xx}(1)}{E_1} \\
&= -\frac{P\sigma_w^2 \cos 4\pi f_1 - P^2 \sin^2 2\pi f_1}{P^2 \sin^2 2\pi f_1 + 2P\sigma_w^2 + \sigma_w^4} \\
a_2(1) &= a_1(1) + a_2(2)a_1(1) \\
&= -\frac{P \cos 2\pi f_1}{P + \sigma_w^2} \left[1 + \frac{P^2 \sin^2 2\pi f_1 - P\sigma_w^2 \cos 4\pi f_1}{P^2 \sin^2 2\pi f_1 + 2P\sigma_w^2 + \sigma_w^4} \right]
\end{aligned}$$

(b) $k_2 = a_2(2)$ $k_1 = a_1(1)$ as given above.

(c)

$$\begin{aligned}
\text{If } \sigma_w^2 &\rightarrow 0, \text{ we have} \\
a_2(1) &= -(\cos 2\pi f_1)(1 + 1) \\
&= -2\cos 2\pi f_1 \\
a_2(2) &= 1
\end{aligned}$$

$$k_2 = 1$$

$$k_1 = -\cos 2\pi f_1$$

12.39

(a)

$$\begin{aligned} \gamma_{xy}(n_0) &= \sum_{n=0}^{N-1} y(n-n_0)[y(n-n_0) + w(n)] \\ E[\gamma_{xy}(n_0)] &= \sum_{n=0}^{N-1} E[y^2(n-n_0)] \\ &= \sum_{n=1}^{N-1} E[A^2 \cos^2 \omega_0(n-n_0)] \quad 0 \leq n \leq M-1 \\ &= \frac{MA^2}{2} \\ \text{var}[\gamma_{xy}(n_0)] &= E[\gamma_{xy}^2(n_0)] \left(\frac{MA^2}{2}\right)^2 \\ &= \sum_n \sum_{n'} E\{y(n-n_0)[y(n-n_0) + w(n)]y(n'-n_0)[y(n'-n_0) + w(n')]\} - \left(\frac{MA^2}{2}\right)^2 \\ &= \frac{MA^2}{2} \sigma_w^2 \end{aligned}$$

(b)

$$\begin{aligned} \text{SNR} &= \frac{\{E[\gamma_{xy}(n_0)]\}^2}{\text{var}[\gamma_{xy}(n_0)]} \\ &= \frac{\left(\frac{MA^2}{2}\right)^2}{\frac{MA^2}{2} \sigma_w^2} \\ &= \frac{MA^2}{2\sigma_w^2} \end{aligned}$$

(c) As M increases, the SNR increases.

12.40

Refer to fig 12.4.

12.41

Refer to fig 12.5.

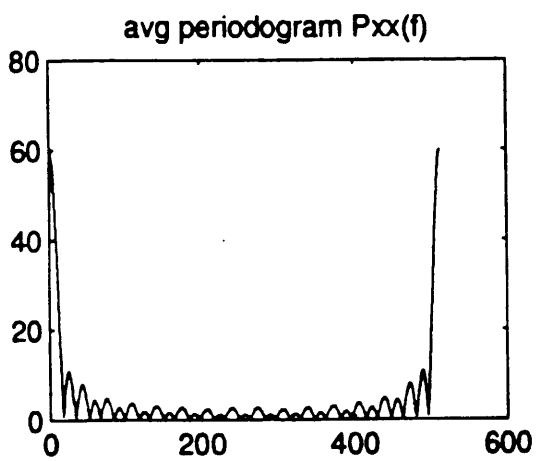
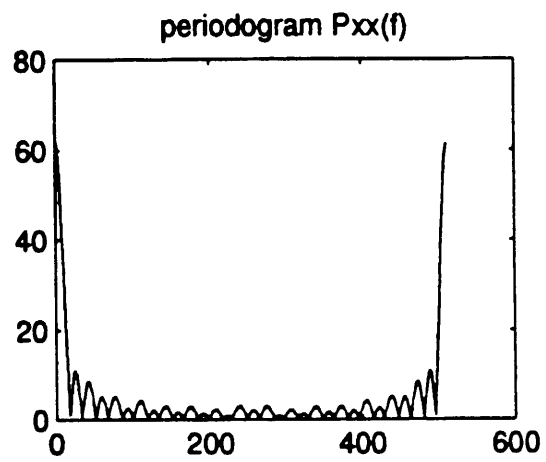
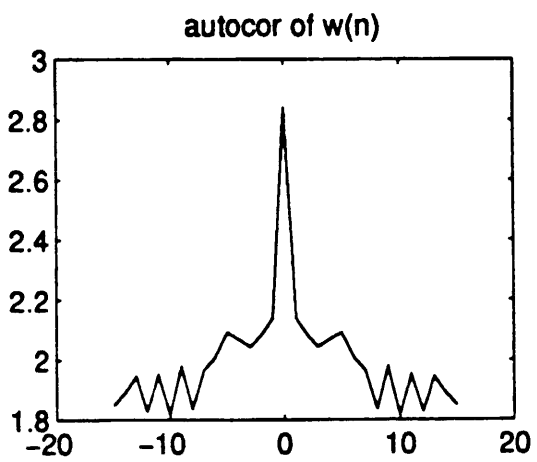

Figure 12.4:

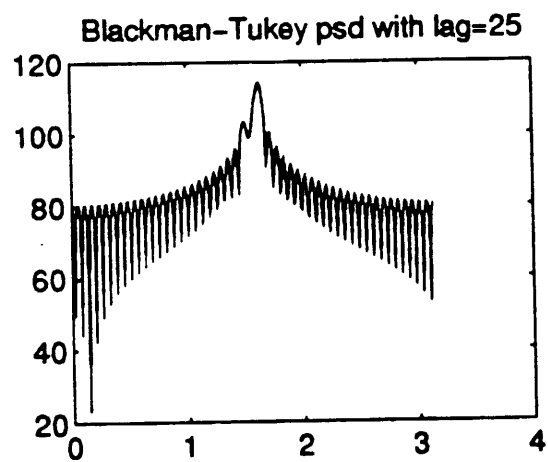
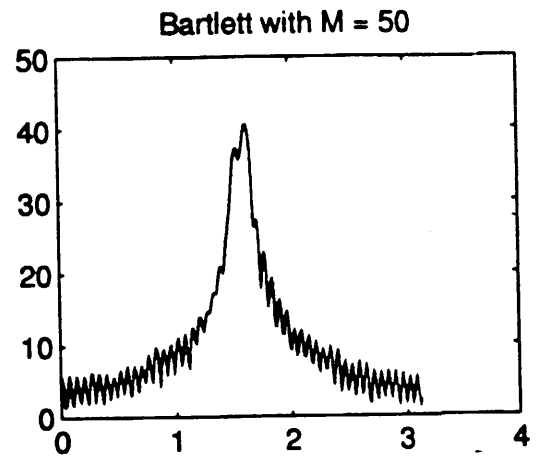
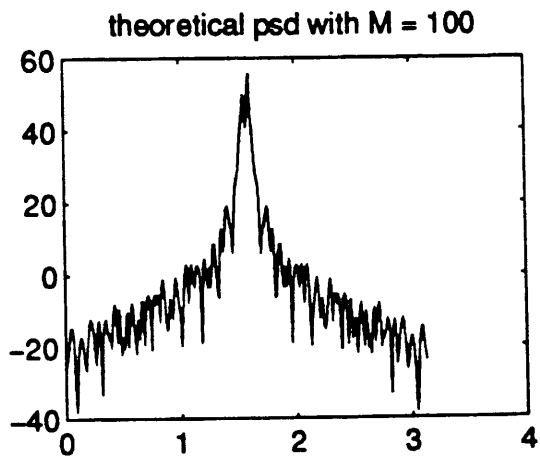

Figure 12.5: