

CHAPTER FOUR

Solutions for Section 4.1

Exercises

1. We sketch a graph which is horizontal at the two critical points. One possibility is shown in Figure 4.1.

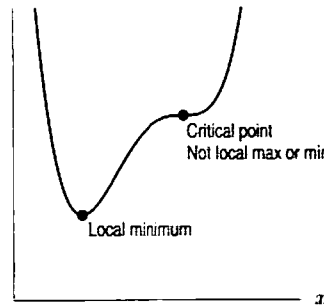

Figure 4.1

2. There are many possible answers. One possible graph is shown in Figure 4.2.

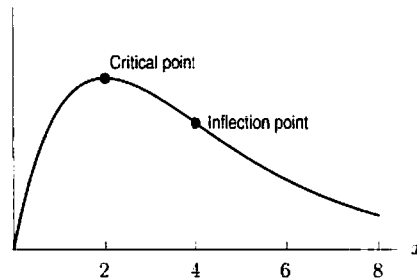
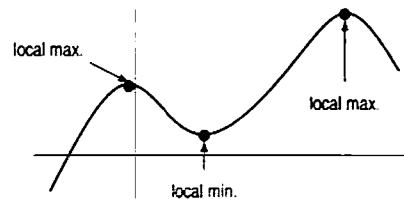
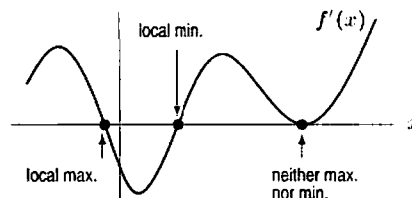

Figure 4.2

3.



4. The critical points of f are zeros of f' . Just to the left of the first critical point $f' > 0$, so f is increasing. Immediately to the right of the first critical point $f' < 0$, so f is decreasing. Thus, the first point must be a maximum. To the left of the second critical point, $f' < 0$, and to its right, $f' > 0$; hence it is a minimum. On either side of the last critical point, $f' > 0$, so it is neither a maximum nor a minimum. See the figure below.



5. (a) A graph of $f(x) = e^{-x^2}$ is shown in Figure 4.3. It appears to have one critical point, at $x = 0$, and two inflection points, one between 0 and 1 and the other between 0 and -1 .

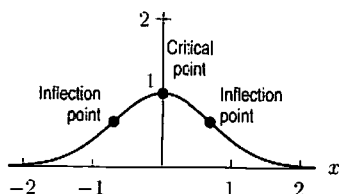

Figure 4.3

- (b) To find the critical points, we set $f'(x) = 0$. Since $f'(x) = -2xe^{-x^2} = 0$, there is one solution, $x = 0$. The only critical point is at $x = 0$.

To find the inflection points, we first use the product rule to find $f''(x)$. We have

$$f''(x) = (-2x)(e^{-x^2}(-2x)) + (-2)(e^{-x^2}) = 4x^2e^{-x^2} - 2e^{-x^2}.$$

We set $f''(x) = 0$ and solve for x by factoring:

$$\begin{aligned} 4x^2e^{-x^2} - 2e^{-x^2} &= 0 \\ (4x^2 - 2)e^{-x^2} &= 0. \end{aligned}$$

Since e^{-x^2} is never zero, we have

$$\begin{aligned} 4x^2 - 2 &= 0 \\ x^2 &= \frac{1}{2} \\ x &= \pm 1/\sqrt{2}. \end{aligned}$$

There are exactly two inflection points, at $x = 1/\sqrt{2} \approx 0.707$ and $x = -1/\sqrt{2} \approx -0.707$.

6. We use the product rule to find $f'(x)$:

$$f'(x) = (10.2x^2)(e^{-0.4x}(-0.4)) + (20.4x)(e^{-0.4x}) = -4.08x^2e^{-0.4x} + 20.4xe^{-0.4x}.$$

To find the critical points, we set $f'(x) = 0$ and solve for x by factoring:

$$\begin{aligned} -4.08x^2e^{-0.4x} + 20.4xe^{-0.4x} &= 0 \\ x(-4.08x + 20.4)e^{-0.4x} &= 0. \end{aligned}$$

Since $e^{-0.4x}$ is never zero, the only two solutions to this equation are $x = 0$ and $x = 20.4/4.08 = 5$. There are exactly two critical points, at $x = 0$ and at $x = 5$. You can sketch a graph of $f(x)$ to check your results.

7. We have

$$g'(x) = e^{-x} - xe^{-x} = (1-x)e^{-x}.$$

Hence $x = 1$ is the only critical point. We see that g' changes from positive to negative at $x = 1$ since e^{-x} is always positive, so by the first-derivative test g has a local maximum at $x = 1$. If we wish to use the second-derivative test, we compute

$$g''(x) = (x-2)e^{-x}$$

and thus $g''(1) = (-1)e^{-1} < 0$, so again $x = 1$ gives a local maximum.

8. For $h(x) = x + \frac{1}{x}$, we calculate

$$h'(x) = 1 - \frac{1}{x^2}$$

and so the critical points of h are at $x = \pm 1$. Now

$$h''(x) = \frac{2}{x^3}$$

so $h''(1) = 2 > 0$ and $x = 1$ gives a local minimum. On the other hand, $h''(-1) = -2 < 0$ so $x = -1$ gives a local maximum.

9. (a) A critical point occurs when $f'(x) = 0$. Since $f'(x)$ changes sign between $x = 2$ and $x = 3$, between $x = 6$ and $x = 7$, and between $x = 9$ and $x = 10$, we expect critical points at around $x = 2.5$, $x = 6.5$, and $x = 9.5$.
 (b) Since $f'(x)$ goes from positive to negative at $x \approx 2.5$, a local maximum should occur there. Similarly, $x \approx 6.5$ is a local minimum and $x \approx 9.5$ a local maximum.

10. To find inflection points of the function f we must find points where f'' changes sign. However, because f'' is the derivative of f' , any point where f'' changes sign will be a local maximum or minimum on the graph of f' .

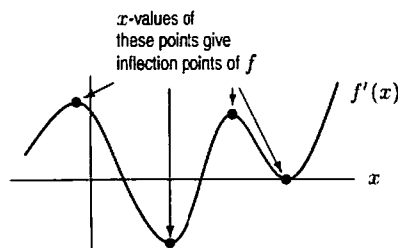

11.

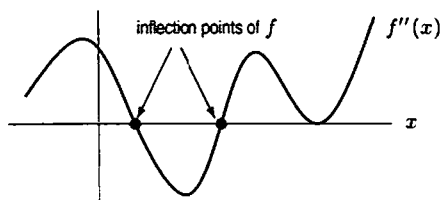

The inflection points of f are the points where f'' changes sign.

12. From the graph of $f(x)$ in the figure below, we see that the function must have two inflection points. We calculate $f'(x) = 4x^3 + 3x^2 - 6x$, and $f''(x) = 12x^2 + 6x - 6$. Solving $f''(x) = 0$ we find that:

$$x_1 = -1 \quad \text{and} \quad x_2 = \frac{1}{2}.$$

Since $f''(x) > 0$ for $x < x_1$, $f''(x) < 0$ for $x_1 < x < x_2$, and $f''(x) > 0$ for $x_2 < x$, it follows that both points are inflection points.

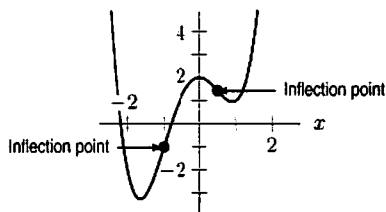

13.

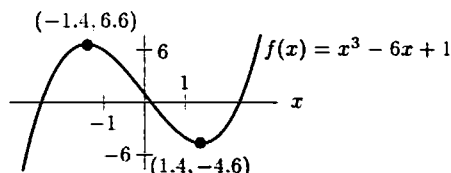

The graph of f above appears to be increasing for $x < -1.4$, decreasing for $-1.4 < x < 1.4$, and increasing for $x > 1.4$. There is a local maximum near $x = -1.4$ and local minimum near $x = 1.4$. The derivative of f is $f'(x) = 3x^2 - 6$. Thus $f'(x) = 0$ when $x^2 = 2$, that is $x = \pm\sqrt{2}$. This explains the critical points near $x = \pm 1.4$. Since $f'(x)$ changes from positive to negative at $x = -\sqrt{2}$, and from negative to positive at $x = \sqrt{2}$, there is a local maximum at $x = -\sqrt{2}$ and a local minimum at $x = \sqrt{2}$.

14.

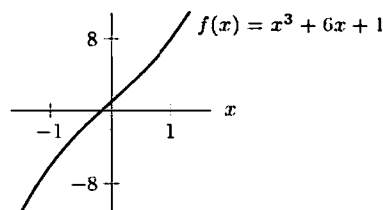

The graph of f in above appears to be increasing for all x , with no critical points. Since $f'(x) = 3x^2 + 6$ and $x^2 \geq 0$ for all x , we have $f'(x) > 0$ for all x . That explains why f is increasing for all x .

15.

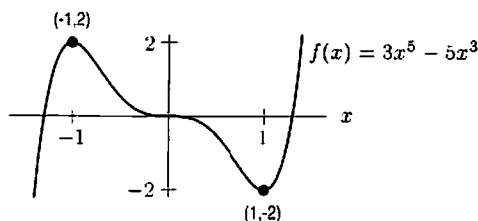

The graph of f above appears to be increasing for $x < -1$, decreasing for $-1 < x < 1$ although it is flat at $x = 0$, and increasing for $x > 1$. There are critical points at $x = -1$ and $x = 1$, and apparently also at $x = 0$. Since $f'(x) = 15x^4 - 15x^2 = 15x^2(x^2 - 1)$, we have $f'(x) = 0$ at $x = 0, -1, 1$. Notice that although $f'(0) = 0$, making $x = 0$ a critical point, there is no change in sign of $f'(x)$ at $x = 0$; the only sign changes are at $x = \pm 1$. Thus the graph of f must alternate increasing/decreasing for $x < -1, -1 < x < 1, x > 1$, just as we described.

16.

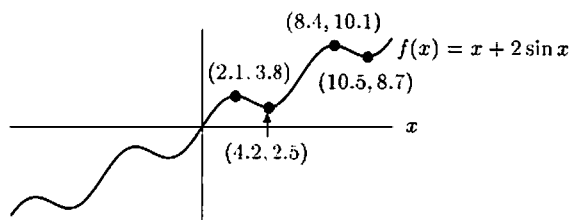

The graph of f above looks like a climbing sine curve, alternately increasing and decreasing, with more time spent increasing than decreasing. Here $f'(x) = 1 + 2 \cos x$, so $f'(x) = 0$ when $\cos x = -1/2$; this occurs when

$$x = \pm \frac{2\pi}{3}, \pm \frac{4\pi}{3}, \pm \frac{8\pi}{3}, \pm \frac{10\pi}{3}, \pm \frac{14\pi}{3}, \pm \frac{16\pi}{3}, \dots$$

Since $f'(x)$ changes sign at each of these values, the graph of f must alternate increasing/decreasing. However, the distance between values of x for critical points alternates between $(2\pi)/3$ and $(4\pi)/3$, with $f'(x) > 0$ on the intervals of length $(4\pi)/3$. For example, $f'(x) > 0$ on the interval $(4\pi)/3 < x < (8\pi)/3$. As a result, f is increasing on the intervals of length $(4\pi)/3$ and decreasing on the intervals of length $(2\pi)/3$.

17.

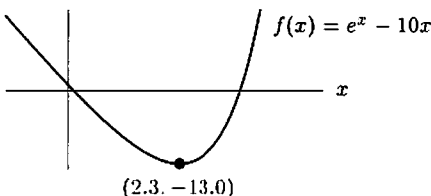

The graph of f above appears to be decreasing for $x < 2.3$ (almost like a straight line for $x < 0$), and increasing sharply for $x > 2.3$. Here $f'(x) = e^x - 10$, so $f'(x) = 0$ when $e^x = 10$, that is $x = \ln 10 = 2.302\dots$. This is the only place where $f'(x)$ changes sign, and it is a minimum of f . Notice that e^x is small for $x < 0$ so $f'(x) \approx -10$ for $x < 0$, which means the graph looks like a straight line of slope -10 for $x < 0$. However, e^x gets large quickly for $x > 0$, so $f'(x)$ gets large quickly for $x > \ln 10$, meaning the graph increases sharply there.

18.

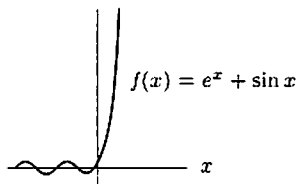

The graph of f above looks like $\sin x$ for $x < 0$ and e^x for $x > 0$. In particular, there are no waves for $x > 0$. We have $f'(x) = \cos x + e^x$, and so the critical points of f occur at those values of x for which $\cos x = -e^x$. Since $e^x > 1$ for all $x > 0$, we know immediately that there are no critical points at positive values of x . The specific locations of the critical points at $x < 0$ must be determined numerically; the first few are $x \approx -1.7, -4.7, -7.9$. For $x < 0$, the quantity e^x is small so that the graph looks like the graph of $\sin x$. For $x > 0$, we have $f'(x) > 0$ since $-1 \leq \cos x$ and $e^x > 1$. Thus, the graph is increasing for all $x > 0$ and there are no such waves.

19.

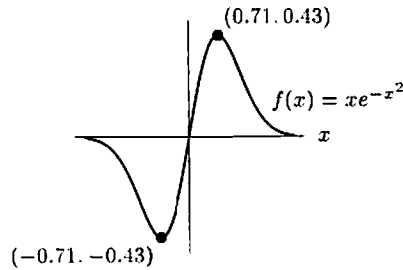

The graph of f above appears to be asymptotic to the x -axis from below for large negative x , decreasing to a global minimum at about $x = -0.71$, increasing to a global maximum at about $x = 0.71$ (passing through the origin along the way), and then decreasing asymptotically to the x -axis from above.

We have $f'(x) = e^{-x^2} + xe^{-x^2}(-2x) = e^{-x^2}(1 - 2x^2)$. Since $e^{-x^2} > 0$ for all x , the sign of $f'(x)$ is the same as the sign of $(1 - 2x^2)$. Thus $f'(x)$ changes sign at $x = \pm 1/\sqrt{2} \approx \pm 0.71$, going from negative to positive to negative, which explains the critical points and increasing/decreasing behavior described. Note that $xe^{-x^2} = x/e^{x^2}$ clearly approaches 0 as $x \rightarrow \pm\infty$, since e^{x^2} is much larger than x when $|x|$ is large. Thus the graph is asymptotic to the x -axis as $x \rightarrow \pm\infty$. Note also that the sign of $f(x) = xe^{-x^2}$ is the same as x , so $f(x) < 0$ for $x < 0$ and $f(x) > 0$ for $x > 0$. Since the graph increases from $x = 0$ to $x = 0.71$ and then decreases, $x = 1/\sqrt{2}$ is the maximum point for $x \geq 0$. Since $f(x) < 0$ for $x < 0$, $x = 1/\sqrt{2}$ is a global maximum. The global minimum at $x = -1/\sqrt{2}$ can be explained similarly.

20.

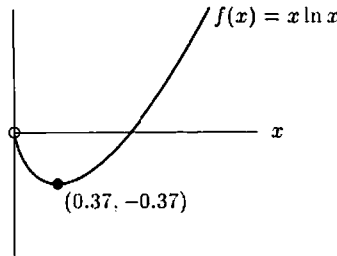

The graph of f above appears to be decreasing for $0 < x < 0.37$, and then increasing for $x > 0.37$. We have $f'(x) = \ln x + x(1/x) = \ln x + 1$, so $f'(x) = 0$ when $\ln x = -1$, that is, $x = e^{-1} \approx 0.37$. This is the only place where f' changes sign and $f'(1) = 1 > 0$, so the graph must decrease for $0 < x < e^{-1}$ and increase for $x > e^{-1}$. Thus, there is a local minimum at $x = e^{-1}$.

21. (13) The graph of $f(x) = x^3 - 6x + 1$ appears to be concave up for $x > 0$ and concave down for $x < 0$, with a point of inflection at $x = 0$. This is because $f''(x) = 6x$ is negative for $x < 0$ and positive for $x > 0$.
- (14) Same answer as number 13.
- (15) There appear to be three points of inflection at about $x = \pm 0.7$ and $x = 0$. This is because $f''(x) = 60x^3 - 30x = 30x(2x^2 - 1)$, which changes sign at $x = 0$ and $x = \pm 1/\sqrt{2}$.
- (16) There appear to be points of inflection equally spaced about 3 units apart. This is because $f''(x) = -2 \sin x$, which changes sign at $x = 0, \pm\pi, \pm 2\pi, \dots$
- (17) The graph appears to be concave up for all x . This is because $f''(x) = e^x > 0$ for all x .
- (18) The graph appears to be concave up for all $x > 0$, and has almost periodic changes in concavity for $x < 0$. This is because for $x > 0$, $f''(x) = e^x - \sin x > 0$, and for $x < 0$, since e^x is small, $f''(x)$ changes sign at approximately the same values of x as $\sin x$.
- (19) There appears to be a point of inflection for some $x < -0.71$, for $x = 0$, and for some $x > 0.71$. This is because $f'(x) = e^{-x^2}(1 - 2x^2)$ so

$$\begin{aligned} f''(x) &= e^{-x^2}(-4x) + (1 - 2x^2)e^{-x^2}(-2x) \\ &= e^{-x^2}(4x^3 - 6x). \end{aligned}$$

Since $e^{-x^2} > 0$, this means $f''(x)$ has the same sign as $(4x^3 - 6x) = 2x(2x^2 - 3)$. Thus $f''(x)$ changes sign at $x = 0$ and $x = \pm\sqrt{3}/2 \approx \pm 1.22$.

- (20) The graph appears to be concave up for all x . This is because $f'(x) = 1 + \ln x$, so $f''(x) = 1/x$, which is greater than 0 for all $x > 0$.

Problems

22. A function may have any number of critical points or none at all. (See Figures 4.4–4.6.)

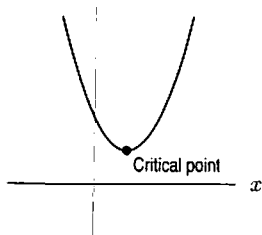

Figure 4.4: A quadratic: One critical point

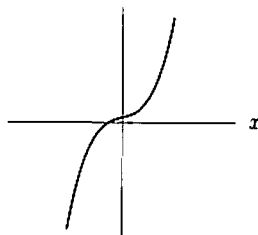

Figure 4.5: $f(x) = x^3 + x + 1$:
No critical points

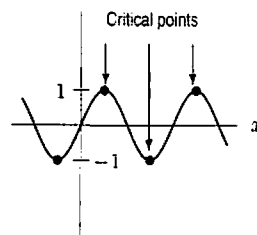

Figure 4.6: $f(x) = \sin x$:
Infinitely many critical points

23. (a) It appears that this function has a local maximum at about $x = 1$, a local minimum at about $x = 4$, and a local maximum at about $x = 8$.
 (b) The table now gives values of the derivative, so critical points occur where $f'(x) = 0$. Since f' is continuous, this occurs between 2 and 3, so there is a critical point somewhere around 2.5. Since f' is positive for values less than 2.5 and negative for values greater than 2.5, it appears that f has a local maximum at about $x = 2.5$. Similarly, it appears that f has a local minimum at about $x = 6.5$ and another local maximum at about $x = 9.5$.
24. First, we wish to have $f'(6) = 0$, since $f(6)$ should be a local minimum:

$$\begin{aligned} f'(x) &= 2x + a = 0 \\ x &= -\frac{a}{2} = 6 \\ a &= -12. \end{aligned}$$

Next, we need to have $f(6) = -5$, since the point $(6, -5)$ is on the graph of $f(x)$. We can substitute $a = -12$ into our equation for $f(x)$ and solve for b :

$$\begin{aligned} f(x) &= x^2 - 12x + b \\ f(6) &= 36 - 72 + b = -5 \\ b &= 31. \end{aligned}$$

Thus, $f(x) = x^2 - 12x + 31$.

25. We wish to have $f'(3) = 0$. Differentiating to find $f'(x)$ and then solving $f'(3) = 0$ for a gives:

$$\begin{aligned} f'(x) &= x(ae^{ax}) + 1(e^{ax}) = e^{ax}(ax + 1) \\ f'(3) &= e^{3a}(3a + 1) = 0 \\ 3a + 1 &= 0 \\ a &= -\frac{1}{3}. \end{aligned}$$

Thus, $f(x) = xe^{-x/3}$.

26. Using the product rule on the function $f(x) = axe^{bx}$, we have $f'(x) = ae^{bx} + abxe^{bx} = ae^{bx}(1 + bx)$. We want $f(\frac{1}{3}) = 1$, and since this is to be a maximum, we require $f'(\frac{1}{3}) = 0$. These conditions give

$$\begin{aligned} f(1/3) &= a(1/3)e^{b/3} = 1, \\ f'(1/3) &= ae^{b/3}(1 + b/3) = 0. \end{aligned}$$

Since $ae^{(1/3)b}$ is non-zero, we can divide both sides of the second equation by $ae^{(1/3)b}$ to obtain $0 = 1 + \frac{b}{3}$. This implies $b = -3$. Plugging $b = -3$ into the first equation gives us $a(\frac{1}{3})e^{-1} = 1$, or $a = 3e$. How do we know we have a maximum at $x = \frac{1}{3}$ and not a minimum? Since $f'(x) = ae^{bx}(1 + bx) = (3e)e^{-3x}(1 - 3x)$, and $(3e)e^{-3x}$ is always positive, it follows that $f'(x) > 0$ when $x < \frac{1}{3}$ and $f'(x) < 0$ when $x > \frac{1}{3}$. Since f' is positive to the left of $x = \frac{1}{3}$ and negative to the right of $x = \frac{1}{3}$, $f(\frac{1}{3})$ is a local maximum.

27. Figure 4.7 contains the graph of $f(x) = x^2 + \cos x$.

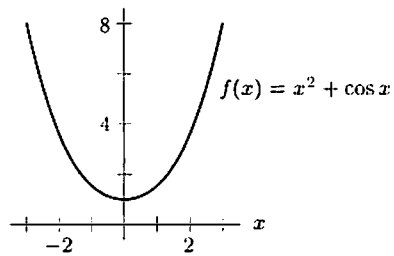

Figure 4.7

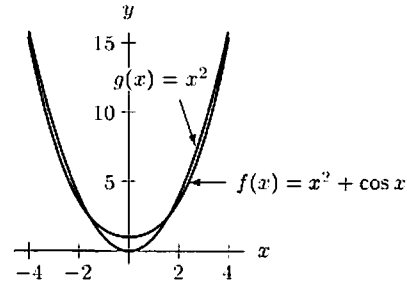

Figure 4.8

The graph looks like a parabola with no waves because $f''(x) = 2 - \cos x$, which is always positive. Thus, the graph of f is concave up everywhere; there are no waves. If you plot the graph of $f(x)$ together with the graph of $g(x) = x^2$, you see that the graph of f does wave back and forth across the graph of g , but never enough to change the concavity of f . See Figure 4.8.

28. (a) From the graph of $P(t) = \frac{2000}{1 + e^{(5.3-0.4t)}}$ in Figure 4.9, we see that the population levels off at about 2000 rabbits.

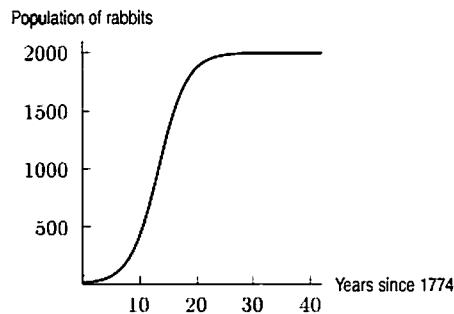

Figure 4.9

- (b) The population appears to have been growing fastest when there were about 1000 rabbits, about 13 years after Captain Cook left them there.
- (c) The rabbits reproduce quickly, so their population initially grew very rapidly. Limited food and space availability and perhaps predators on the island probably account for the population being unable to grow past 2000.
29. (a) Since the volume of water in the container is proportional to its depth, and the volume is increasing at a constant rate,

$$d(t) = \text{Depth at time } t = Kt,$$

where K is some positive constant. So the graph is linear, as shown in Figure 4.10. Since initially no water is in the container, we have $d(0) = 0$, and the graph starts from the origin.

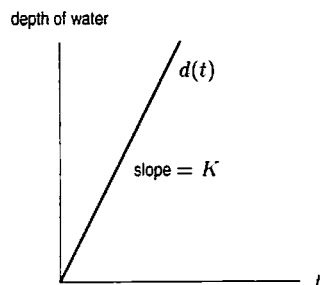

Figure 4.10

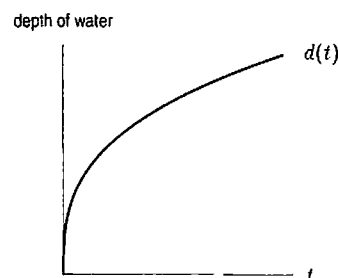
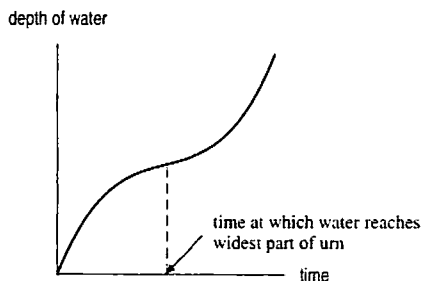

Figure 4.11

- (b) As time increases, the additional volume needed to raise the water level by a fixed amount increases. Thus, although the depth, $d(t)$, of water in the cone at time t , continues to increase, it does so more and more slowly. This means $d'(t)$ is positive but decreasing, i.e., $d(t)$ is concave down. See Figure 4.11.

30.



31.

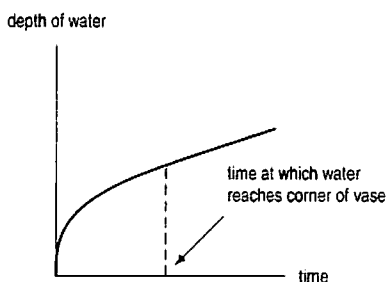

32. From the first condition, we get that $x = 2$ is a local minimum for f . From the second condition, it follows that $x = 4$ is an inflection point. A possible graph is shown in Figure 4.12.

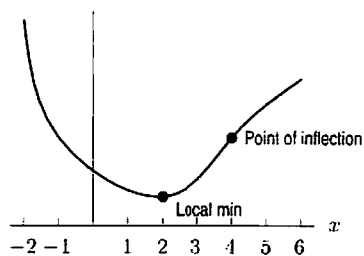
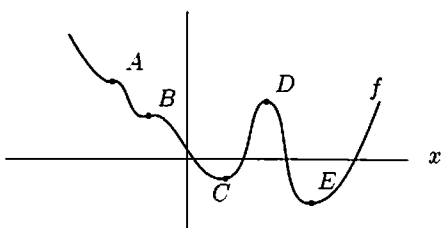
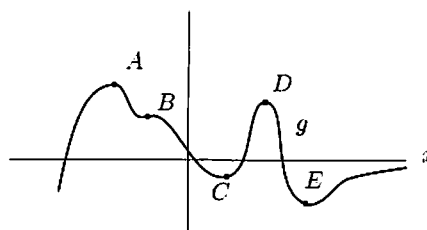

Figure 4.12

33. (a)



(b)



34. Since f is differentiable everywhere, f' must be zero (not undefined) at any critical points; thus, $f'(3) = 0$. Since f has exactly one critical point, f' may change sign only at $x = 3$. Thus f is always increasing or always decreasing for $x < 3$ and for $x > 3$. Using the information in parts (a) through (d), we determine whether $x = 3$ is a local minimum, local maximum, or neither.

(a) $x = 3$ is a local maximum because $f(x)$ is increasing when $x < 3$ and decreasing when $x > 3$.

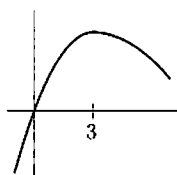

(b) $x = 3$ is a local minimum because $f(x)$ heads to infinity to either side of $x = 3$.

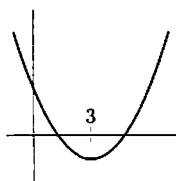

(c) $x = 3$ is neither a local minimum nor maximum, as $f(1) < f(2) < f(4) < f(5)$.

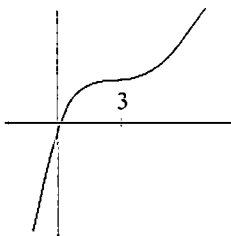

(d) $x = 3$ is a local minimum because $f(x)$ is decreasing to the left of $x = 3$ and must increase to the right of $x = 3$, as $f(3) = 1$ and eventually $f(x)$ must become close to 3.

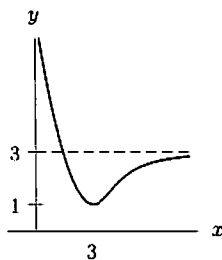

35. (a) This is one of many possible graphs.

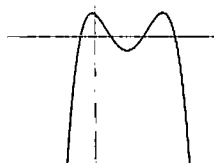

(b) Since f must have a bump between each pair of zeros, f could have at most four zeros.

(c) f could well have no zeros at all. To see this, consider the graph of the above function shifted vertically downwards.

(d) f must have at least two inflection points. Since f has 3 maxima or minima, it has 3 critical points. Consequently f' will have 3 corresponding zeros. Between each consecutive pair of these zeros f' must have a local maximum or minimum. Thus f' will have one local maximum and one local minimum, which implies that f'' will have two zeros. These values, where the second derivative is zero, correspond to points of inflection on the graph of f .

(e) The 3 critical points are zeros of f' , so $\text{degree}(f') \geq 3$. Thus $\text{degree}(f) \geq 4$.

(f) For example:

$$f(x) = \frac{-2}{15}(x+1)(x-1)(x-3)(x-5)$$

will look something like the graph in part (a). Many other answers are possible.

36. Neither B nor C is 0 where A has its maxima and minimum. Therefore neither B nor C is the derivative of A , so $A = f''$. We can see B could be the derivative of C because where C has a maximum, B is 0. However, C is not the derivative of B because B is decreasing for some x -values and C is never negative. Thus, $C = f$, $B = f'$, and $A = f''$.
37. A has zeros where B has maxima and minima, so A could be a derivative of B . This is confirmed by comparing intervals on which B is increasing and A is positive. (They are the same.) So, C is either the derivative of A or the derivative of C is B . However, B does not have a zero at the point where C has a minimum, so B cannot be the derivative of C . Therefore, C is the derivative of A . So $B = f$, $A = f'$, and $C = f''$.
38. Since the derivative of an even function is odd and the derivative of an odd function is even, f and f'' are either both odd or both even, and f' is the opposite. Graphs I and III represent even functions; II represents an odd function, so II is f' . Since the maxima and minima of II occur where I crosses the x -axis, I must be the derivative of f' , that is, f'' . In addition, the maxima and minima of III occur where II crosses the x -axis, so III is f .
39. Since the derivative of an even function is odd and the derivative of an odd function is even, f and f'' are either both odd or both even, and f' is the opposite. Graphs I and II represent odd functions; III represents an even function, so III is f' . Since the maxima and minima of III occur where I crosses the x -axis, I must be the derivative of f' , that is, f'' . In addition, the maxima and minima of II occur where III crosses the x -axis, so II is f .

40.

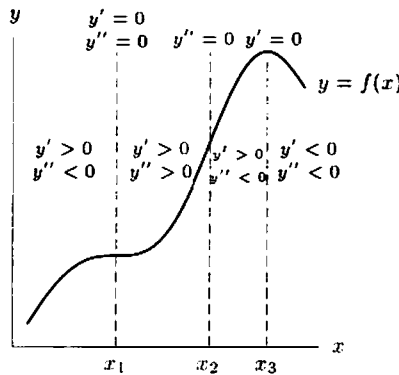

41.

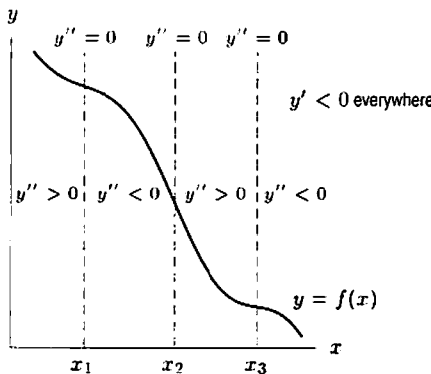

42.

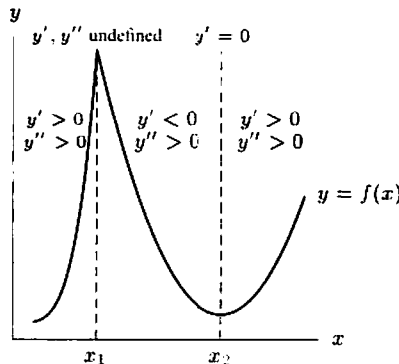

43.

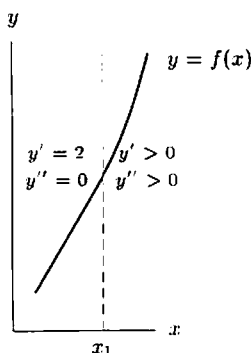

44. (a) When a number grows larger, its reciprocal grows smaller. Therefore, since f is increasing near x_0 , we know that g (its reciprocal) must be decreasing. Another argument can be made using derivatives. We know that (since f is increasing) $f'(x) > 0$ near x_0 . We also know (by the chain rule) that $g'(x) = (f(x)^{-1})' = -\frac{f'(x)}{f(x)^2}$. Since both $f'(x)$ and $f(x)^2$ are positive, this means $g'(x)$ is negative, which in turn means $g(x)$ is decreasing near $x = x_0$.
- (b) Since f has a local maximum near x_1 , $f(x)$ increases as x nears x_1 , and then $f(x)$ decreases as x exceeds x_1 . Thus the reciprocal of f , g , decreases as x nears x_1 and then increases as x exceeds x_1 . Thus g has a local minimum at $x = x_1$. To put it another way, since f has a local maximum at $x = x_1$, we know $f'(x_1) = 0$. Since $g'(x) = -\frac{f'(x)}{f(x)^2}$, $g'(x_1) = 0$. To the left of x_1 , $f'(x_1)$ is positive, so $g'(x)$ is negative. To the right of x_1 , $f'(x_1)$ is negative, so $g'(x)$ is positive. Therefore, g has a local minimum at x_1 .
- (c) Since f is concave down at x_2 , we know $f''(x_2) < 0$. We also know (from above) that

$$g''(x_2) = \frac{2f'(x_2)^2}{f(x_2)^3} - \frac{f''(x_2)}{f(x_2)^2} = \frac{1}{f(x_2)^2} \left(\frac{2f'(x_2)^2}{f(x_2)} - f''(x_2) \right).$$

Since $\frac{1}{f(x_2)^2} > 0$, $2f'(x_2)^2 > 0$, and $f(x_2) > 0$ (as f is assumed to be everywhere positive), we see that $g''(x_2)$ is positive. Thus g is concave up at x_2 .

Note that for the first two parts of the problem, we didn't need to require f to be positive (only non-zero). However, it was necessary here.

45. (a) Since $f''(x) > 0$ and $g''(x) > 0$ for all x , then $f''(x) + g''(x) > 0$ for all x , so $f(x) + g(x)$ is concave up for all x .
- (b) Nothing can be concluded about the concavity of $(f + g)(x)$. For example, if $f(x) = ax^2$ and $g(x) = bx^2$ with $a > 0$ and $b < 0$, then $(f + g)''(x) = a + b$. So $f + g$ is either always concave up, always concave down, or a straight line, depending on whether $a > |b|$, $a < |b|$, or $a = |b|$. More generally, it is even possible that $(f + g)(x)$ may have one or more changes in concavity.
- (c) It is possible to have infinitely many changes in concavity. Consider $f(x) = x^2 + \cos x$ and $g(x) = -x^2$. Since $f''(x) = 2 - \cos x$, we see that $f(x)$ is concave up for all x . Clearly $g(x)$ is concave down for all x . However, $f(x) + g(x) = \cos x$, which changes concavity an infinite number of times.

Solutions for Section 4.2

Exercises

1. We want a function of the form $y = a(x - h)^2 + k$, with $a < 0$ because the parabola opens downward. Since (h, k) is the vertex, we must take $h = 2$, $k = 5$, but we can take any negative value of a . Figure 4.13 shows the graph with $a = -1$, namely $y = -(x - 2)^2 + 5$.

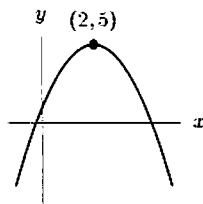

Figure 4.13: Graph of $y = -(x - 2)^2 + 5$

2. A circle with center (h, k) and radius r has equation $(x - h)^2 + (y - k)^2 = r^2$. Thus $h = -1$, $k = 2$, and $r = 3$, giving

$$(x + 1)^2 + (y - 2)^2 = 9.$$

Solving for y , and taking the positive square root gives the top half, so

$$(y - 2)^2 = 9 - (x + 1)^2$$

$$y = 2 + \sqrt{9 - (x + 1)^2}.$$

See Figure 4.14.

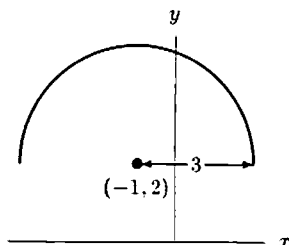

Figure 4.14: Graph of $y = 2 + \sqrt{9 - (x + 1)^2}$

3. Since the horizontal asymptote is $y = 5$, we know $a = 5$. The value of b can be any number. Thus $y = 5(1 - e^{-bx})$ for any $b > 0$.
4. Since the maximum is on the y -axis, $a = 0$. At that point, $y = be^{-0^2/2} = b$, so $b = 3$.
5. Since the vertical asymptote is $x = 2$, we have $b = -2$. The fact that the horizontal asymptote is $y = -5$ gives $a = -5$. So

$$y = \frac{-5x}{x - 2}.$$

6. A cubic polynomial of the form $y = a(x - 1)(x - 5)(x - 7)$ has the correct intercepts for any value of $a \neq 0$. Figure 4.15 shows the graph with $a = 1$, namely $y = (x - 1)(x - 5)(x - 7)$.

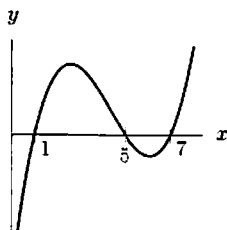

Figure 4.15: Graph of $y = (x - 1)(x - 5)(x - 7)$

7. Since the maximum is $y = 2$ and the minimum is $y = 1.5$, the amplitude is $A = (2 - 1.5)/2 = 0.25$. Between the maximum and the minimum, the x -value changes by 10. There is half a period between a maximum and the next minimum, so the period is 20. Thus

$$\frac{2\pi}{B} = 20 \quad \text{so} \quad B = \frac{\pi}{10}.$$

The mid-line is $y = C = (2 + 1.5)/2 = 1.75$. Figure 4.16 shows a graph of the function

$$y = 0.25 \sin\left(\frac{\pi x}{10}\right) + 1.75.$$

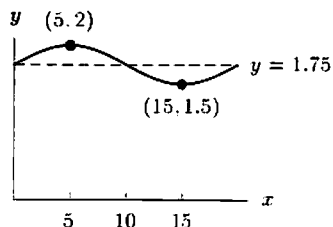

Figure 4.16: Graph of $y = 0.25 \sin(\pi x/10) + 1.75$

8. Since the x^3 term has coefficient of 1, the cubic polynomial is of the form $y = x^3 + ax^2 + bx + c$. We now find a , b , and c . Differentiating gives

$$\frac{dy}{dx} = 3x^2 + 2ax + b.$$

The derivative is 0 at local maxima and minima, so

$$\left. \frac{dy}{dx} \right|_{x=1} = 3(1)^2 + 2a(1) + b = 3 + 2a + b = 0$$

$$\left. \frac{dy}{dx} \right|_{x=3} = 3(3)^2 + 2a(3) + b = 27 + 6a + b = 0$$

Subtracting the first equation from the second and solving for a and b gives

$$24 + 4a = 0 \quad \text{so} \quad a = -6$$

$$b = -3 - 2(-6) = 9.$$

Since the y -intercept is 5, the cubic is

$$y = x^3 - 6x^2 + 9x + 5.$$

Since the coefficient of x^3 is positive, $x = 1$ is the maximum and $x = 3$ is the minimum. See Figure 4.17. To confirm that $x = 1$ gives a maximum and $x = 3$ gives a minimum, we calculate

$$\frac{d^2y}{dx^2} = 6x + 2a = 6x - 12.$$

At $x = 1$, $\frac{d^2y}{dx^2} = -6 < 0$, so we have a maximum.

At $x = 3$, $\frac{d^2y}{dx^2} = 6 > 0$, so we have a minimum.

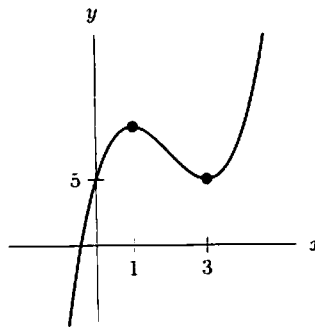

Figure 4.17: Graph of $y = x^3 - 6x^2 + 9x + 5$

9. Since the graph of the quartic polynomial is symmetric about the y -axis, the quartic must have only even powers and be of the form

$$y = ax^4 + bx^2 + c.$$

The y -intercept is 3, so $c = 3$. Differentiating gives

$$\frac{dy}{dx} = 4ax^3 + 2bx.$$

Since there is a maximum at $(1, 4)$, we have $dy/dx = 0$ if $x = 1$, so

$$4a(1)^3 + 2b(1) = 4a + 2b = 0 \quad \text{so} \quad b = -2a.$$

The fact that $dy/dx = 0$ if $x = -1$ gives us the same relationship

$$-4a - 2b = 0 \quad \text{so} \quad b = -2a.$$

We also know that $y = 4$ if $x = \pm 1$, so

$$a(1)^4 + b(1)^2 + 3 = a + b + 3 = 4 \quad \text{so} \quad a + b = 1.$$

Solving for a and b gives

$$a - 2a = 1 \quad \text{so} \quad a = -1 \text{ and } b = 2.$$

Finding d^2y/dx^2 so that we can check that $x = \pm 1$ are maxima, not minima, we see

$$\frac{d^2y}{dx^2} = 12ax^2 + 2b = -12x^2 + 4.$$

Thus $\frac{d^2y}{dx^2} = -8 < 0$ for $x = \pm 1$, so $x = \pm 1$ are maxima. See Figure 4.18.

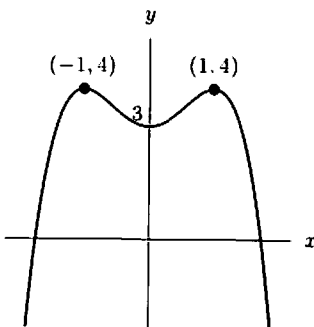

Figure 4.18: Graph of $y = -x^4 + 2x^2 + 3$

10. The maximum of $y = e^{-(x-a)^2/b}$ occurs at $x = a$. (This is because the exponent $-(x-a)^2/b$ is zero when $x = a$ and negative for all other x -values. The same result can be obtained by taking derivatives.) Thus we know that $a = 2$.

Points of inflection occur where d^2y/dx^2 changes sign, that is, where $d^2y/dx^2 = 0$. Differentiating gives

$$\begin{aligned} \frac{dy}{dx} &= -\frac{2(x-2)}{b} e^{-(x-2)^2/b} \\ \frac{d^2y}{dx^2} &= -\frac{2}{b} e^{-(x-2)^2/b} + \frac{4(x-2)^2}{b^2} e^{-(x-2)^2/b} = \frac{2}{b} e^{-(x-2)^2/b} \left(-1 + \frac{2}{b}(x-2)^2 \right). \end{aligned}$$

Since $e^{-(x-2)^2/b}$ is never zero, $d^2y/dx^2 = 0$ where

$$-1 + \frac{2}{b}(x-2)^2 = 0.$$

We know $d^2y/dx^2 = 0$ at $x = 1$, so substituting $x = 1$ gives

$$-1 + \frac{2}{b}(1-2)^2 = 0.$$

Solving for b gives

$$\begin{aligned} -1 + \frac{2}{b} &= 0 \\ b &= 2. \end{aligned}$$

Since $a = 2$, the function is

$$y = e^{-(x-2)^2/2}.$$

You can check that at $x = 2$, we have

$$\frac{d^2y}{dx^2} = \frac{2}{2} e^{-0}(-1 + 0) < 0$$

so the point $x = 2$ does indeed give a maximum. See Figure 4.19.

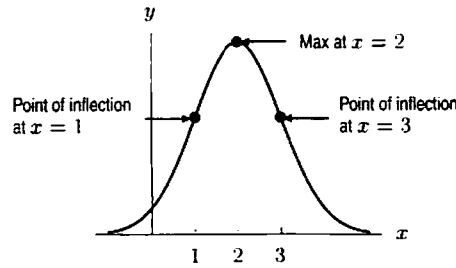
Figure 4.19: Graph of $y = e^{-(x-2)^2/2}$

11. Differentiating $y = ax^b \ln x$, we have

$$\frac{dy}{dx} = abx^{b-1} \ln x + ax^b \cdot \frac{1}{x} = ax^{b-1}(b \ln x + 1).$$

Since the maximum occurs at $x = e^2$, we know that

$$a(e^2)^{b-1}(b \ln(e^2) + 1) = 0.$$

Since $a \neq 0$ and $(e^2)^{b-1} \neq 0$ for all b , we have

$$b \ln(e^2) + 1 = 0.$$

Since $\ln(e^2) = 2$, the equation becomes

$$\begin{aligned} 2b + 1 &= 0 \\ b &= -\frac{1}{2}. \end{aligned}$$

Thus $y = ax^{-1/2} \ln x$. When $x = e^2$, we know $y = 6e^{-1}$, so

$$\begin{aligned} y &= a(e^2)^{-1/2} \ln e^2 = ae^{-1}(2) = 6e^{-1} \\ a &= 3. \end{aligned}$$

Thus $y = 3x^{-1/2} \ln x$. To check that $x = e^2$ gives a local maximum, we differentiate twice

$$\begin{aligned} \frac{dy}{dx} &= -\frac{3}{2}x^{-3/2} \ln x + 3x^{-1/2} \cdot \frac{1}{x} = -\frac{3}{2}x^{-3/2} \ln x + 3x^{-3/2} \\ \frac{d^2y}{dx^2} &= \frac{9}{4}x^{-5/2} \ln x - \frac{3}{2}x^{-3/2} \cdot \frac{1}{x} - \frac{3}{2} \cdot 3x^{-5/2} \\ &= \frac{9}{4}x^{-5/2} \ln x - 6x^{-5/2} = \frac{3}{4}x^{-5/2}(3 \ln x - 8). \end{aligned}$$

At $x = e^2$, since $\ln(e^2) = 2$, we have a maximum because

$$\frac{d^2y}{dx^2} = \frac{3}{4}(e^2)^{-5/2}(3 \ln(e^2) - 8) = \frac{3}{4}e^{-5}(3 \cdot 2 - 8) < 0.$$

See Figure 4.20.

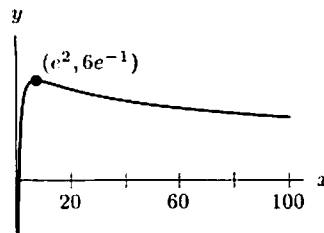
Figure 4.20: Graph of $y = 3x^{-1/2} \ln x$

Problems

12. (a) Let $p(x) = x^3 - ax$, and suppose $a < 0$. Then $p'(x) = 3x^2 - a > 0$ for all x , so $p(x)$ is always increasing.
 (b) Now suppose $a > 0$. We have $p'(x) = 3x^2 - a = 0$ when $x^2 = a/3$, i.e., when $x = \sqrt{a/3}$ and $x = -\sqrt{a/3}$. We also have $p''(x) = 6x$: so $x = \sqrt{a/3}$ is a local minimum since $6\sqrt{a/3} > 0$, and $x = -\sqrt{a/3}$ is a local maximum since $-6\sqrt{a/3} < 0$.
 (c) Case 1: $a < 0$
 In this case, $p(x)$ is always increasing. We have $p''(x) = 6x > 0$ if $x > 0$, meaning the graph is concave up for $x > 0$. Furthermore, $6x < 0$ if $x < 0$, meaning the graph is concave down for $x < 0$. Thus, $x = 0$ is an inflection point.

Case 2: $a > 0$

We have

$$p\left(\sqrt{\frac{a}{3}}\right) = \left(\sqrt{\frac{a}{3}}\right)^3 - a\sqrt{\frac{a}{3}} = \frac{a\sqrt{a}}{\sqrt{27}} - \frac{a\sqrt{a}}{\sqrt{3}} = -\frac{2a\sqrt{a}}{3\sqrt{3}} < 0,$$

$$\text{and } p\left(-\sqrt{\frac{a}{3}}\right) = -\frac{a\sqrt{a}}{\sqrt{27}} + \frac{a\sqrt{a}}{\sqrt{3}} = -p\left(\sqrt{\frac{a}{3}}\right) > 0.$$

$$p'(x) = 3x^2 - a \begin{cases} = 0 & \text{if } |x| = \sqrt{\frac{a}{3}}; \\ > 0 & \text{if } |x| > \sqrt{\frac{a}{3}}; \\ < 0 & \text{if } |x| < \sqrt{\frac{a}{3}}. \end{cases}$$

So p is increasing for $x < -\sqrt{a/3}$, decreasing for $-\sqrt{a/3} < x < \sqrt{a/3}$, and increasing for $x > \sqrt{a/3}$. Since $p''(x) = 6x$, the graph of $p(x)$ is concave down for values of x less than zero and concave up for values greater than zero. Graphs of $p(x)$ for $a < 0$ and $a > 0$ are found in Figures 4.21 and 4.22, respectively.

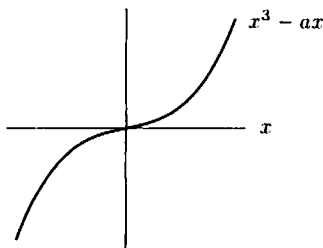

Figure 4.21: $p(x)$ for $a < 0$

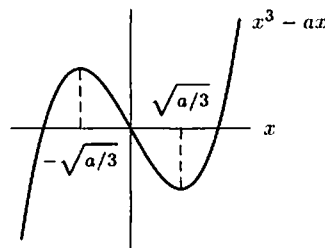

Figure 4.22: $p(x)$ for $a > 0$

13. (a) We have $p'(x) = 3x^2 - a$, so

$$\begin{array}{c} p \text{ increasing} \quad | \quad p \text{ decreasing} \quad | \quad p \text{ increasing} \\ \hline x = -\sqrt{\frac{a}{3}} \quad \quad \quad x = \sqrt{\frac{a}{3}} \end{array}$$

$$\text{Local maximum: } p\left(-\sqrt{\frac{a}{3}}\right) = \frac{-a\sqrt{a}}{\sqrt{27}} + \frac{a\sqrt{a}}{\sqrt{3}} = +\frac{2a\sqrt{a}}{3\sqrt{3}}$$

$$\text{Local minimum: } p\left(\sqrt{\frac{a}{3}}\right) = -p\left(-\sqrt{\frac{a}{3}}\right) = -\frac{2a\sqrt{a}}{3\sqrt{3}}$$

- (b) Increasing the value of a moves the critical points of p away from the y -axis, and moves the critical values away from the x -axis. Thus, the “bumps” get further apart and higher. At the same time, increasing the value of a spreads the zeros of p further apart (while leaving the one at the origin fixed).
 (c) See Figure 4.23

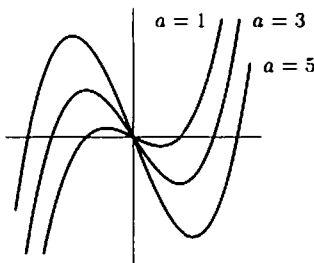
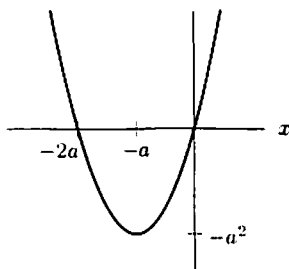

Figure 4.23

14. We have $f(x) = x^2 + 2ax = x(x + 2a) = 0$ when $x = 0$ or $x = -2a$.

$$f'(x) = 2x + 2a = 2(x + a) \begin{cases} = 0 & \text{when } x = -a \\ > 0 & \text{when } x > -a \\ < 0 & \text{when } x < -a. \end{cases}$$

See figure below. Furthermore, $f''(x) = 2$, so that $f(-a) = -a^2$ is a global minimum, and the graph is always concave up.



Increasing $|a|$ stretches the graph horizontally. Also, the critical value (the value of f at the critical point) drops further beneath the x -axis. Letting $a < 0$ would reflect the graph shown through the y -axis.

15. Since $\lim_{t \rightarrow \infty} N = a$, we have $a = 200,000$. Note that while $N(t)$ will never actually reach 200,000, it will become arbitrarily close to 200,000. Since N represents the number of people, it makes sense to round up long before $t \rightarrow \infty$. When $t = 1$, we have $N = 0.1(200,000) = 20,000$ people, so plugging into our formula gives

$$N(1) = 20,000 = 200,000 (1 - e^{-k(1)}).$$

Solving for k gives

$$\begin{aligned} 0.1 &= 1 - e^{-k} \\ e^{-k} &= 0.9 \\ k &= -\ln 0.9 \approx 0.105. \end{aligned}$$

16. $T(t)$ = the temperature at time $t = a(1 - e^{-kt}) + b$.

(a) Since at time $t = 0$ the yam is at 20°C , we have

$$T(0) = 20^\circ = a(1 - e^0) + b = a(1 - 1) + b = b.$$

Thus $b = 20^\circ\text{C}$. Now, common sense tells us that after a period of time, the yam will heat up to about 200° , or oven temperature. Thus the temperature T should approach 200° as the time t grows large:

$$\lim_{t \rightarrow \infty} T(t) = 200^\circ\text{C} = a(1 - 0) + b = a + b.$$

Since $a + b = 200^\circ$, and $b = 20^\circ\text{C}$, this means $a = 180^\circ\text{C}$.

(b) Since we're talking about how quickly the yam is heating up, we need to look at the derivative, $T'(t) = ake^{-kt}$:

$$T'(t) = (180)ke^{-kt}.$$

We know $T'(0) = 2^\circ\text{C}/\text{min}$, so

$$2 = (180)ke^{-k(0)} = (180)(k).$$

So $k = (2^\circ\text{C}/\text{min})/180^\circ\text{C} = \frac{1}{90}\text{min}^{-1}$.

17. We begin by finding the intercepts, which occur where $f(x) = 0$, that is

$$\begin{aligned} x - k\sqrt{x} &= 0 \\ \sqrt{x}(\sqrt{x} - k) &= 0 \end{aligned}$$

$$\text{so } x = 0 \text{ or } \sqrt{x} = k, \quad x = k^2.$$

So 0 and k^2 are the x -intercepts. Now we find the location of the critical points by setting $f'(x)$ equal to 0:

$$f'(x) = 1 - k \left(\frac{1}{2} x^{-(1/2)} \right) = 1 - \frac{k}{2\sqrt{x}} = 0.$$

This means

$$1 = \frac{k}{2\sqrt{x}}, \quad \text{so } \sqrt{x} = \frac{1}{2}k, \quad \text{and } x = \frac{1}{4}k^2.$$

We can use the second derivative to verify that $x = \frac{k^2}{4}$ is a local minimum. $f''(x) = 1 + \frac{k}{4x^{3/2}}$ is positive for all $x > 0$. So the critical point, $x = \frac{1}{4}k^2$, is $1/4$ of the way between the x -intercepts, $x = 0$ and $x = k^2$. Since $f''(x) = \frac{1}{4}kx^{-3/2}$, $f''(\frac{1}{4}k^2) = 2/k^2 > 0$, this critical point is a minimum.

18. Graphs of $y = xe^{-bx}$ for $b = 1, 2, 3, 4$ are shown below. All the graphs rise at first, passing through the origin, reach a maximum and then decay toward 0. If b is small, the graph rises longer and to a higher maximum before the decay begins.

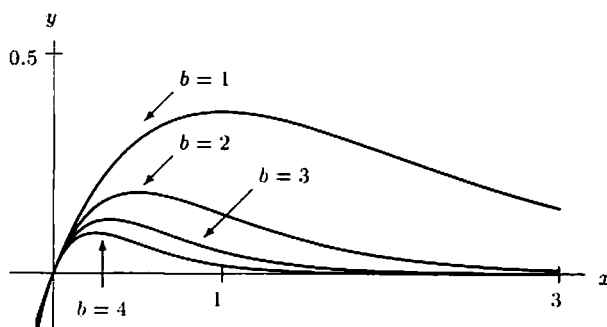

19. Since

$$\frac{dy}{dx} = (1 - bx)e^{-bx},$$

we see

$$\frac{dy}{dx} = 0 \quad \text{at } x = \frac{1}{b}.$$

The critical point has coordinates $(1/b, 1/(be))$. If b is small, the x and y -coordinates of the critical point are both large, indicating a higher maximum further to the right. See figure below.

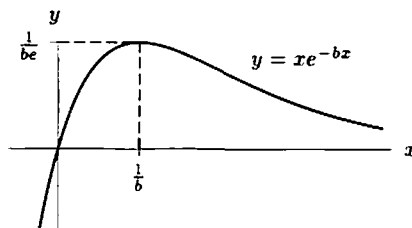

20. (a) $f'(x) = 4x^3 + 2ax = 2x(2x^2 + a)$; so $x = 0$ and $x = \pm\sqrt{-a/2}$ (if $\pm\sqrt{-a/2}$ is real, i.e. if $-a/2 \geq 0$) are critical points.
- (b) $x = 0$ is a critical point for any value of a . In order to guarantee that $x = 0$ is the only critical point, the factor $2x^2 + a$ should not have a root other than possibly $x = 0$. This means $a \geq 0$, since $2x^2 + a$ has only one root ($x = 0$) for $a = 0$, and no roots for $a > 0$. There is no restriction on the constant b .
Now $f''(x) = 12x^2 + 2a$ and $f''(0) = 2a$.
If $a > 0$, then by the second derivative test, $f(0)$ is a local minimum.
If $a = 0$, then $f(x) = x^4 + b$, which has a local minimum at $x = 0$.
So $x = 0$ is a local minimum when $a \geq 0$.
- (c) Again, b will have no effect on the location of the critical points. In order for $f'(x) = 2x(2x^2 + a)$ to have three different roots, the constant a has to be negative. Let $a = -2c^2$, for some $c > 0$. Then $f'(x) = 4x(x^2 - c^2) = 4x(x - c)(x + c)$.

The critical points of f are $x = 0$ and $x = \pm c = \pm\sqrt{-a/2}$.

To the left of $x = -c$, $f'(x) < 0$.

Between $x = -c$ and $x = 0$, $f'(x) > 0$.

Between $x = 0$ and $x = c$, $f'(x) < 0$.

To the right of $x = c$, $f'(x) > 0$.

So, $f(-c)$ and $f(c)$ are local minima and $f(0)$ is a local maximum.

(d) For $a \geq 0$, there is exactly one critical point, $x = 0$. For $a < 0$ there are exactly three different critical points. These exhaust all the possibilities. (Notice that the value of b is irrelevant here.)

21. Since $f'(x) = abe^{-bx}$, we have $f'(x) > 0$ for all x . Therefore, f is increasing for all x . Since $f''(x) = -ab^2e^{-bx}$, we have $f''(x) < 0$ for all x . Therefore, f is concave down for all x .
22. (a) The graph of r has a vertical asymptote if the denominator is zero. Since $(x - b)^2$ is nonnegative, the denominator can only be zero if $a \leq 0$. Then

$$\begin{aligned} a + (x - b)^2 &= 0 \\ (x - b)^2 &= -a \\ x - b &= \pm\sqrt{-a} \\ x &= b \pm \sqrt{-a}. \end{aligned}$$

In order for there to be a vertical asymptote, a must be less than or equal to zero. There are no restrictions on b .

(b) Differentiating gives

$$r'(x) = \frac{-1}{(a + (x - b)^2)^2} \cdot 2(x - b),$$

so $r' = 0$ when $x = b$. If $a \leq 0$, then r' is undefined at the same points at which r is undefined. Thus the only critical point is $x = b$. Since we want $r(x)$ to have a maximum at $x = 3$, we choose $b = 3$. Also, since $r(3) = 5$, we have

$$r(3) = \frac{1}{a + (3 - 3)^2} = \frac{1}{a} = 5 \quad \text{so} \quad a = \frac{1}{5}.$$

23. (a) The x -intercept occurs where $f(x) = 0$, so

$$\begin{aligned} ax - x \ln x &= 0 \\ x(a - \ln x) &= 0. \end{aligned}$$

Since $x > 0$, we must have

$$\begin{aligned} a - \ln x &= 0 \\ \ln x &= a \\ x &= e^a. \end{aligned}$$

- (b) See Figures 4.24 and 4.25.

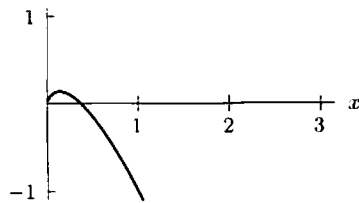

Figure 4.24: Graph of $f(x)$ with $a = -1$

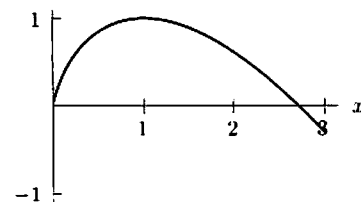

Figure 4.25: Graph of $f(x)$ with $a = 1$

- (c) Differentiating gives $f'(x) = a - \ln x - 1$. Critical points are obtained by solving

$$\begin{aligned} a - \ln x - 1 &= 0 \\ \ln x &= a - 1 \\ x &= e^{a-1}. \end{aligned}$$

Since $e^{a-1} > 0$ for all a , there is no restriction on a . Now,

$$f(e^{a-1}) = ae^{a-1} - e^{a-1} \ln(e^{a-1}) = ae^{a-1} - (a-1)e^{a-1} = e^{a-1}.$$

so the coordinates of the critical point are (e^{a-1}, e^{a-1}) . From the graphs, we see that this critical point is a local maximum; this can be confirmed using the second derivative:

$$f''(x) = -\frac{1}{x} < 0 \quad \text{for } x = e^{a-1}.$$

24. (a) Figures 4.26- 4.29 show graphs of $f(x) = x^2 + \cos(kx)$ for various values of k . For $k = 0.5$ and $k = 1$, the graphs look like parabolas. For $k = 3$, there is some waving in the parabola, which becomes more noticeable if $k = 5$. The waving begins to happen at about $k = 1.5$.

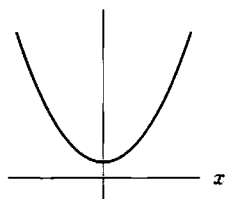

Figure 4.26: $k = 0.5$

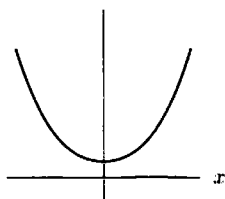

Figure 4.27: $k = 1$

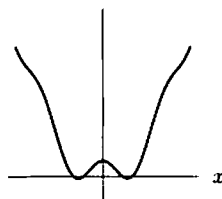

Figure 4.28: $k = 3$

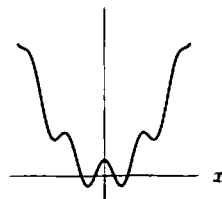

Figure 4.29: $k = 5$

- (b) Differentiating, we have

$$f'(x) = 2x - k \sin(kx)$$

$$f''(x) = 2 - k^2 \cos(kx).$$

If $k^2 \leq 2$, then $f''(x) \geq 2 - 2 \cos(kx) \geq 0$, since $\cos(kx) \leq 1$. Thus, the graph is always concave up if $k \leq \sqrt{2}$. If $k^2 > 2$, then $f''(x)$ changes sign whenever $\cos(kx) = 2/k^2$, which occurs for infinitely many values of x , since $0 < 2/k^2 < 1$.

- (c) Since $f'(x) = 2x - k \sin(kx)$, we want to find all points where

$$2x - k \sin(kx) = 0.$$

Since

$$-1 \leq \sin(kx) \leq 1,$$

$f'(x) \neq 0$ if $x > k/2$ or $x < -k/2$. Thus, all the roots of $f'(x)$ must be in the interval $-k/2 \leq x \leq k/2$. The roots occur where the line $y = 2x$ intersects the curve $y = k \sin(kx)$, and there are only a finite number of such points for $-k/2 \leq x \leq k/2$.

25. (a) Figure 4.30 suggests that each graph decreases to a local minimum and then increases sharply. The local minimum appears to move to the right as k increases. It appears to move up until $k = 1$, and then to move back down.

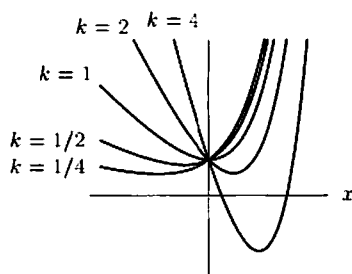

Figure 4.30

- (b) $f'(x) = e^x - k = 0$ when $x = \ln k$. Since $f'(x) < 0$ for $x < \ln k$ and $f'(x) > 0$ for $x > \ln k$, f is decreasing to the left of $x = \ln k$ and increasing to the right, so f reaches a local minimum at $x = \ln k$.

(c) The minimum value of f is

$$f(\ln k) = e^{\ln k} - k(\ln k) = k - k \ln k.$$

Since we want to maximize the expression $k - k \ln k$, we can imagine a function $g(k) = k - k \ln k$. To maximize this function we simply take its derivative and find the critical points. Differentiating, we obtain

$$g'(k) = 1 - \ln k - k(1/k) = -\ln k.$$

Thus $g'(k) = 0$ when $k = 1$, $g'(k) > 0$ for $k < 1$, and $g'(k) < 0$ for $k > 1$. Thus $k = 1$ is a local maximum for $g(k)$. That is, the largest global minimum for f occurs when $k = 1$.

26. Let $f(x) = Ae^{-Bx^2}$. Since

$$f(x) = Ae^{-Bx^2} = Ae^{-\frac{(x-0)^2}{(1/B)}}.$$

this is just the family of curves $y = e^{\frac{(x-a)^2}{b}}$ multiplied by a constant A . This family of curves is discussed in the text; here, $a = 0$, $b = \frac{1}{B}$. When $x = 0$, $y = Ae^0 = A$, so A determines the y -intercept. A also serves to flatten or stretch the graph of e^{-Bx^2} vertically. Since $f'(x) = -2ABxe^{-Bx^2}$, $f(x)$ has a critical point at $x = 0$. For $B > 0$, the graphs are bell-shaped curves centered at $x = 0$, and $f(0) = A$ is a global maximum.

To find the inflection points of f , we solve $f''(x) = 0$. Since $f'(x) = -2ABxe^{-Bx^2}$,

$$f''(x) = -2ABe^{-Bx^2} + 4AB^2x^2e^{-Bx^2}.$$

Since e^{-Bx^2} is always positive, $f''(x) = 0$ when

$$\begin{aligned} -2AB + 4AB^2x^2 &= 0 \\ x^2 &= \frac{2AB}{4AB^2} \\ x &= \pm \sqrt{\frac{1}{2B}}. \end{aligned}$$

These are points of inflection, since the second derivative changes sign here. Thus for large values of B , the inflection points are close to $x = 0$, and for smaller values of B the inflection points are further from $x = 0$. Therefore B affects the width of the graph.

In the graphs in Figure 4.31, A is held constant, and variations in B are shown.

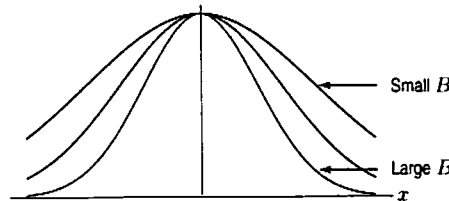

Figure 4.31: $f(x) = Ae^{-Bx^2}$ for varying B

27. (a) Let $f(x) = axe^{-bx}$. To find the local maxima and local minima of f , we solve

$$f'(x) = ae^{-bx} - abxe^{-bx} = ae^{-bx}(1 - bx) \begin{cases} = 0 & \text{if } x = 1/b \\ < 0 & \text{if } x > 1/b \\ > 0 & \text{if } x < 1/b. \end{cases}$$

Therefore, f is increasing ($f' > 0$) for $x < 1/b$ and decreasing ($f' < 0$) for $x > 1/b$. A local maximum occurs at $x = 1/b$. There are no local minima. To find the points of inflection, we write

$$\begin{aligned} f''(x) &= -abe^{-bx} + ab^2xe^{-bx} - abe^{-bx} \\ &= -2abe^{-bx} + ab^2xe^{-bx} \\ &= ab(bx - 2)e^{-bx}. \end{aligned}$$

so $f'' = 0$ at $x = 2/b$. Therefore, f is concave up for $x < 2/b$ and concave down for $x > 2/b$, and the inflection point is $x = 2/b$.

- (b) Varying a stretches or flattens the graph but does not affect the critical point $x = 1/b$ and the inflection point $x = 2/b$. Since the critical and inflection points are depend on b , varying b will change these points, as well as the maximum $f(1/b) = a/be$. For example, an increase in b will shift the critical and inflection points to the left, and also lower the maximum value of f .

(c)

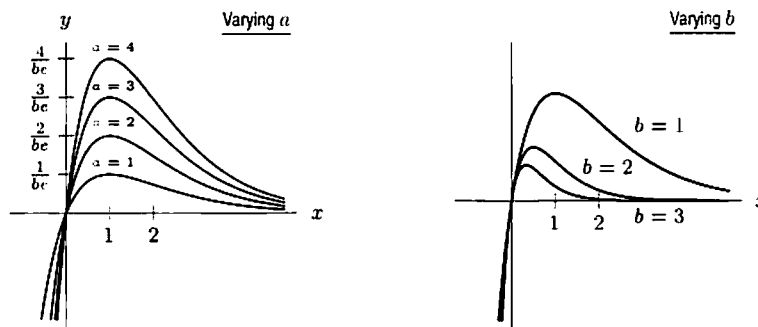

28. Graphs of $y = e^{-ax} \sin(bx)$ for $b = 1$ and various values of a are shown in Figure 4.32. The parameter a controls the amplitude of the oscillations.

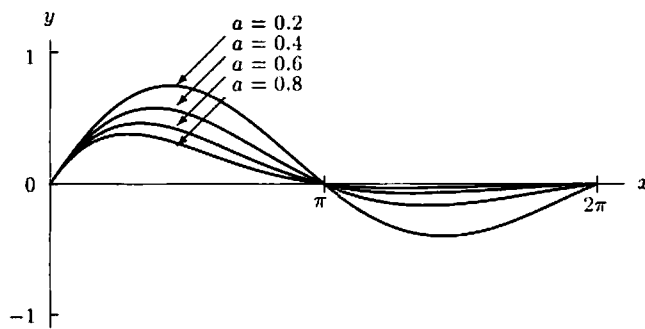
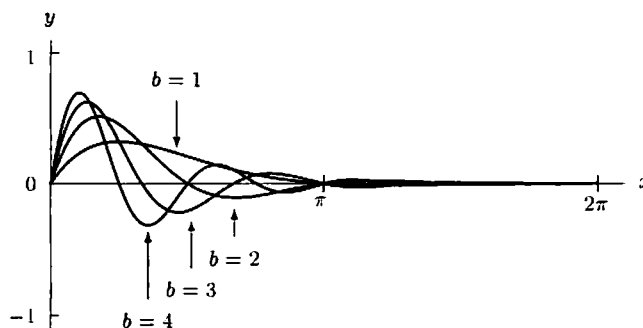

Figure 4.32

29.



The larger the value of b , the narrower the humps and more humps per given region there are in the graph.

30. (a) The larger the value of $|A|$, the steeper the graph (for the same x -value).
 (b) The graph is shifted horizontally by B . The shift is to the left for positive B , to the right for negative B . There is a vertical asymptote at $x = -B$.
 (c)

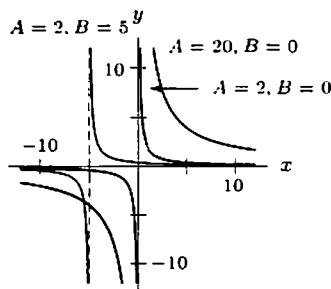

31. (a) Since

$$U = b \left(\frac{a^2 - ax}{x^2} \right) = 0 \quad \text{when } x = a,$$

the x -intercept is $x = a$. There is a vertical asymptote at $x = 0$ and a horizontal asymptote at $U = 0$.

(b) Setting $dU/dx = 0$, we have

$$\frac{dU}{dx} = b \left(-\frac{2a^2}{x^3} + \frac{a}{x^2} \right) = b \left(\frac{-2a^2 + ax}{x^3} \right) = 0.$$

So the critical point is

$$x = 2a.$$

When $x = 2a$,

$$U = b \left(\frac{a^2}{4a^2} - \frac{a}{2a} \right) = -\frac{b}{4}.$$

The second derivative of U is

$$\frac{d^2U}{dx^2} = b \left(\frac{6a^2}{x^4} - \frac{2a}{x^3} \right).$$

When we evaluate this at $x = 2a$, we get

$$\frac{d^2U}{dx^2} = b \left(\frac{6a^2}{(2a)^4} - \frac{2a}{(2a)^3} \right) = \frac{b}{8a^2} > 0.$$

Since $d^2U/dx^2 > 0$ at $x = 2a$, we see that the point $(2a, -b/4)$ is a local minimum.

(c)

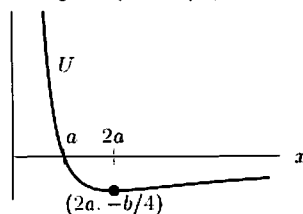

32. Both U and F have asymptotes at $x = 0$ and the x -axis. In Problem 31 we saw that U has intercept $(a, 0)$ and local minimum $(2a, -b/4)$. Differentiating U gives

$$F = b \left(\frac{2a^2}{x^3} - \frac{a}{x^2} \right).$$

Since

$$F = b \left(\frac{2a^2 - ax}{x^3} \right) = 0 \quad \text{for } x = 2a.$$

F has one intercept: $(2a, 0)$. Differentiating again to find the critical points:

$$\frac{dF}{dx} = b \left(-\frac{6a^2}{x^4} + \frac{2a}{x^3} \right) = b \left(\frac{-6a^2 + 2ax}{x^4} \right) = 0.$$

so $x = 3a$. When $x = 3a$,

$$F = b \left(\frac{2a^2}{27a^3} - \frac{a}{9a^2} \right) = -\frac{b}{27a}.$$

By the first or second derivative test, $x = 3a$ is a local minimum of F . See figure below.

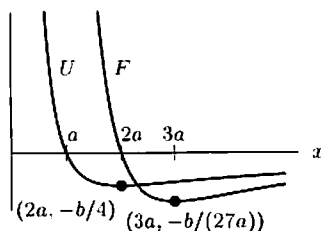

33. (a) The force is zero where

$$\begin{aligned} f(r) &= -\frac{A}{r^2} + \frac{B}{r^3} = 0 \\ Ar^3 &= Br^2 \\ r &= \frac{B}{A}. \end{aligned}$$

The vertical asymptote is $r = 0$ and the horizontal asymptote is the r -axis.

- (b) To find critical points, we differentiate and set
- $f'(r) = 0$
- :

$$\begin{aligned} f'(r) &= \frac{2A}{r^3} - \frac{3B}{r^4} = 0 \\ 2Ar^4 &= 3Br^3 \\ r &= \frac{3B}{2A}. \end{aligned}$$

Thus, $r = 3B/(2A)$ is the only critical point. Since $f'(r) < 0$ for $r < 3B/(2A)$ and $f'(r) > 0$ for $r > 3B/(2A)$, we see that $r = 3B/(2A)$ is a local minimum. At that point,

$$f\left(\frac{3B}{2A}\right) = -\frac{A}{9B^2/4A^2} + \frac{B}{27B^3/8A^3} = -\frac{4A^3}{27B^2}.$$

Differentiating again, we have

$$f''(r) = -\frac{6A}{r^4} + \frac{12B}{r^5} = -\frac{6}{r^5}(Ar - 2B).$$

So $f''(r) < 0$ where $r > 2B/A$ and $f''(r) > 0$ when $r < 2B/A$. Thus, $r = 2B/A$ is the only point of inflection. At that point

$$f\left(\frac{2B}{A}\right) = -\frac{A}{4B^2/A^2} + \frac{B}{8B^3/A^3} = -\frac{A^3}{8B^2}.$$

- (c)

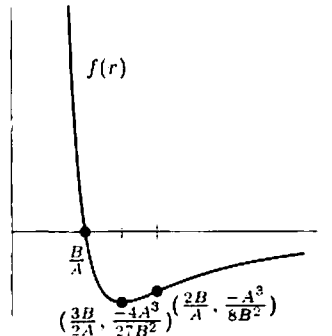

- (d) (i) Increasing B means that the r -values of the zero, the minimum, and the inflection point increase, while the $f(r)$ values of the minimum and the point of inflection decrease in magnitude. See Figure 4.33.
- (ii) Increasing A means that the r -values of the zero, the minimum, and the point of inflection decrease, while the $f(r)$ values of the minimum and the point of inflection increase in magnitude. See Figure 4.34.

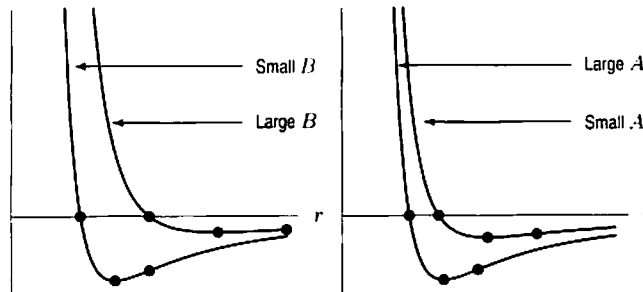
Figure 4.33: Increasing B Figure 4.34: Increasing A

34. (a) See Figure 4.35.

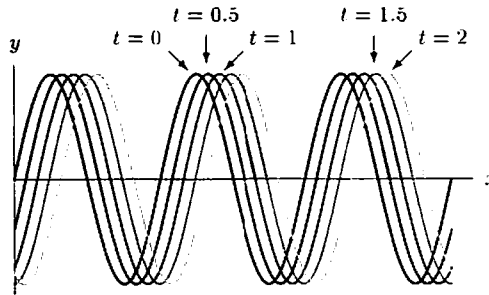

Figure 4.35

- (b) (i) For fixed t , the function represents the surface of the water at time t . The shape of the surface is a sine wave of period 2π .
- (ii) For fixed x , the function represents the vertical (up-and-down) motion of a particle at position x .
- (c) For fixed t , the derivative dy/dx represents the slope of the surface of the wave at position x and time t .
- (d) For fixed x , the derivative dy/dt represents the vertical velocity of a particle of water at position x and time t .

Solutions for Section 4.3

Exercises

1.

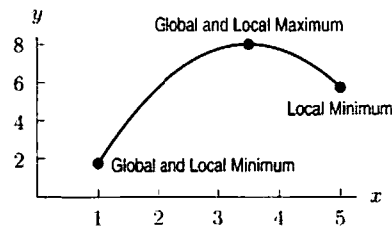

2.

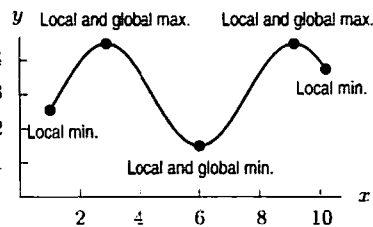

The global maximum is achieved at the two local maxima, which are at the same height.

3. (a) We have $f'(x) = 10x^9 - 10 = 10(x^9 - 1)$. This is zero when $x = 1$, so $x = 1$ is a critical point of f . For values of x less than 1, x^9 is less than 1, and thus $f'(x)$ is negative when $x < 1$. Similarly, $f'(x)$ is positive for $x > 1$. Thus $f(1) = -9$ is a local minimum.
- We also consider the endpoints $f(0) = 0$ and $f(2) = 1004$. Since $f'(0) < 0$ and $f'(2) > 0$, we see $x = 0$ and $x = 2$ are local maxima.
- (b) Comparing values of f shows that the global minimum is at $x = 1$, and the global maximum is at $x = 2$.
4. (a) $f'(x) = 1 - 1/x$. This is zero only when $x = 1$. Now $f'(x)$ is positive when $1 < x \leq 2$, and negative when $0.1 < x < 1$. Thus $f(1) = 1$ is a local minimum. The endpoints $f(0.1) \approx 2.4026$ and $f(2) \approx 1.3069$ are local maxima.
- (b) Comparing values of f shows that $x = 0.1$ gives the global maximum and $x = 1$ gives the global minimum.

5. (a) Differentiating

$$f(x) = \sin^2 x - \cos x \quad \text{for } 0 \leq x \leq \pi$$

$$f'(x) = 2 \sin x \cos x + \sin x = (\sin x)(2 \cos x + 1)$$

$f'(x) = 0$ when $\sin x = 0$ or when $2 \cos x + 1 = 0$. Now, $\sin x = 0$ when $x = 0$ or when $x = \pi$. On the other hand, $2 \cos x + 1 = 0$ when $\cos x = -1/2$, which happens when $x = 2\pi/3$. So the critical points are $x = 0$, $x = 2\pi/3$, and $x = \pi$.

Note that $\sin x > 0$ for $0 < x < \pi$. Also, $2 \cos x + 1 < 0$ if $2\pi/3 < x \leq \pi$ and $2 \cos x + 1 > 0$ if $0 < x < 2\pi/3$. Therefore,

$$f'(x) < 0 \quad \text{for } \frac{2\pi}{3} < x < \pi$$

$$f'(x) > 0 \quad \text{for } 0 < x < \frac{2\pi}{3}.$$

Thus f has a local maximum at $x = 2\pi/3$ and local minima at $x = 0$ and $x = \pi$.

(b) We have

$$f(0) = [\sin(0)]^2 - \cos(0) = -1$$

$$f\left(\frac{2\pi}{3}\right) = \left[\sin\left(\frac{2\pi}{3}\right)\right]^2 - \cos\frac{2\pi}{3} = 1.25$$

$$f(\pi) = [\sin(\pi)]^2 - \cos(\pi) = 1.$$

Thus the global maximum is at $x = 2\pi/3$, and the global minimum is at $x = 0$.

Problems

6. (a) We know that $h''(x) < 0$ for $-2 \leq x < -1$, $h''(-1) = 0$, and $h''(x) > 0$ for $x > -1$. Thus, $h'(x)$ decreases to its minimum value at $x = -1$, which we know to be zero, and then increases; it is never negative.
- (b) Since $h'(x)$ is non-negative for $-2 \leq x \leq 1$, we know that $h(x)$ is never decreasing on $[-2, 1]$. So a global maximum must occur at the right hand endpoint of the interval.
- (c) The graph below shows a function that is increasing on the interval $-2 \leq x \leq 1$ with a horizontal tangent and an inflection point at $(-1, 2)$.

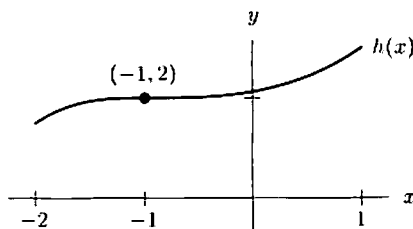

7. We want to maximize the height, y , of the grapefruit above the ground, as shown in the figure below. Using the derivative we can find exactly when the grapefruit is at the highest point. We can think of this in two ways. By common sense, at the peak of the grapefruit's flight, the velocity, dy/dt , must be zero. Alternately, we are looking for a global maximum of y , so we look for critical points where $dy/dt = 0$. We have

$$\frac{dy}{dt} = -32t + 50 = 0 \quad \text{and so} \quad t = \frac{-50}{-32} \approx 1.56 \text{ sec.}$$

Thus, we have the time at which the height is a maximum; the maximum value of y is then

$$y \approx -16(1.56)^2 + 50(1.56) + 5 = 44.1 \text{ feet.}$$

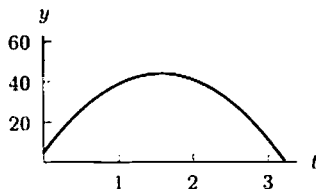

8. (a) We have

$$T(D) = \left(\frac{C}{2} - \frac{D}{3}\right)D^2 = \frac{CD^2}{2} - \frac{D^3}{3},$$

and

$$\frac{dT}{dD} = CD - D^2 = D(C - D).$$

Since, by this formula, dT/dD is zero when $D = 0$ or $D = C$, negative when $D > C$, and positive when $D < C$, we have (by the first derivative test) that the temperature change is maximized when $D = C$.

- (b) The sensitivity is $dT/dD = CD - D^2$; its derivative is $d^2T/dD^2 = C - 2D$, which is zero if $D = C/2$, negative if $D > C/2$, and positive if $D < C/2$. Thus by the first derivative test the sensitivity is maximized at $D = C/2$.

9. We have that $v(r) = a(R - r)r^2 = aRr^2 - ar^3$, and $v'(r) = 2aRr - 3ar^2 = 2ar(R - \frac{3}{2}r)$, which is zero if $r = \frac{2}{3}R$, or if $r = 0$, and so $v(r)$ has critical points there.

$v''(r) = 2aR - 6ar$, and thus $v''(0) = 2aR > 0$, which by the second derivative test implies that v has a minimum at $r = 0$. $v''(\frac{2}{3}R) = 2aR - 4aR = -2aR < 0$, and so by the second derivative test v has a maximum at $r = \frac{2}{3}R$. In fact, this is a global max of $v(r)$ since $v(0) = 0$ and $v(R) = 0$ at the endpoints.

10. (a) If we expect the rate to be nonnegative, then we must have $0 \leq y \leq a$. See Figure 4.36.

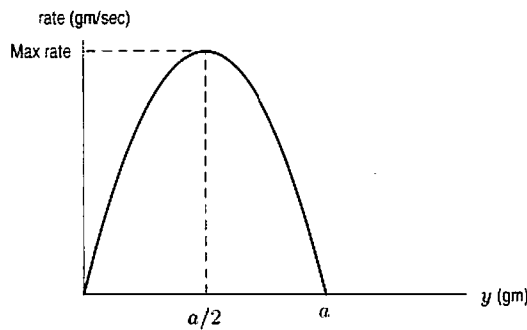

Figure 4.36

- (b) The maximum value of the rate occurs at $y = a/2$, as can be seen from Figure 4.36, or by setting

$$\frac{d}{dy}(\text{rate}) = 0$$

$$\frac{d}{dy}(\text{rate}) = \frac{d}{dy}(kay - ky^2) = ka - 2ky = 0$$

$$y = \frac{a}{2}.$$

From the graph, we see that $y = a/2$ gives the global maximum.

11. (a) If we expect the rate to be nonnegative, we must have $0 \leq y \leq a$ and $0 \leq y \leq b$. Since we assume $a < b$, we restrict y to $0 \leq y \leq a$.

In fact, the expression for the rate is nonnegative for y greater than b , but these values of y are not meaningful for the reaction. See Figure 4.37.

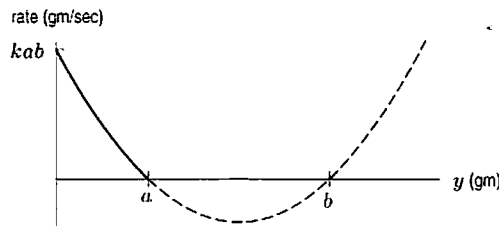

Figure 4.37

- (b) From the graph, we see that the maximum rate occurs when $y = 0$; that is, at the start of the reaction.

12. (a) Since a/q decreases with q , this term represents the ordering cost. Since bq increases with q , this term represents the storage cost.

(b) At the minimum,

$$\frac{dC}{dq} = \frac{-a}{q^2} + b = 0$$

giving

$$q^2 = \frac{a}{b} \quad \text{so} \quad q = \sqrt{\frac{a}{b}}.$$

Since

$$\frac{d^2C}{dq^2} = \frac{2a}{q^3} > 0 \quad \text{for} \quad q > 0.$$

we know that $q = \sqrt{a/b}$ gives a local minimum. Since $q = \sqrt{a/b}$ is the only critical point, this must be the global minimum.

13. We set $f'(r) = 0$ to find the critical points:

$$\begin{aligned} \frac{2A}{r^3} - \frac{3B}{r^4} &= 0 \\ \frac{2Ar - 3B}{r^4} &= 0 \\ 2Ar - 3B &= 0 \\ r &= \frac{3B}{2A}. \end{aligned}$$

The only critical point is at $r = 3B/(2A)$. If $r > 3B/(2A)$, we have $f' > 0$ and if $r < 3B/(2A)$, we have $f' < 0$. Thus, the force between the atoms is minimized at $r = 3B/(2A)$.

14. We set $dU/dx = 0$ to find the critical points:

$$\begin{aligned} b \left(\frac{-2a^2}{x^3} + \frac{a}{x^2} \right) &= 0 \\ -2a^2 + ax &= 0 \\ x &= 2a. \end{aligned}$$

The only critical point is at $x = 2a$. When $x < 2a$ we have $dU/dx < 0$, and when $x > 2a$ we have $dU/dx > 0$. The potential energy, U , is minimized at $x = 2a$.

15. We look for critical points of M :

$$\frac{dM}{dx} = \frac{1}{2}wL - wx.$$

Now $dM/dx = 0$ when $x = L/2$. At this point $d^2M/dx^2 = -w$ so this point is a local maximum. The graph of $M(x)$ is a parabola opening downwards, so the local maximum is also the global maximum.

- 16.

$$\frac{dE}{d\theta} = \frac{(\mu + \theta)(1 - 2\mu\theta) - (\theta - \mu\theta^2)}{(\mu + \theta)^2} = \frac{\mu(1 - 2\mu\theta - \theta^2)}{(\mu + \theta)^2}.$$

Now $dE/d\theta = 0$ when $\theta = -\mu \pm \sqrt{1 + \mu^2}$. Since $\theta > 0$, the only possible critical point is when $\theta = -\mu + \sqrt{\mu^2 + 1}$. Differentiating again gives $E'' < 0$ at this point and so it is a local maximum. Since $E(\theta)$ is continuous for $\theta > 0$ and $E(\theta)$ has only one critical point, the local maximum is the global maximum.

17. A graph of F against θ is shown below.

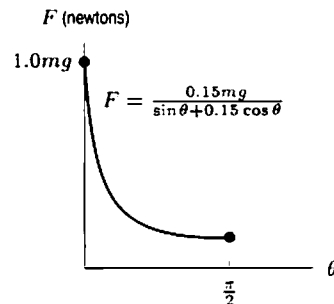

Taking the derivative:

$$\frac{dF}{d\theta} = -\frac{mg\mu(\cos\theta - \mu\sin\theta)}{(\sin\theta + \mu\cos\theta)^2}.$$

At a critical point, $dF/d\theta = 0$, so

$$\begin{aligned}\cos\theta - \mu\sin\theta &= 0 \\ \tan\theta &= \frac{1}{\mu} \\ \theta &= \arctan\left(\frac{1}{\mu}\right).\end{aligned}$$

If $\mu = 0.15$, then $\theta = \arctan(1/0.15) = 1.422 \approx 81.5^\circ$. To calculate the maximum and minimum values of F , we evaluate at this critical point and the endpoints:

$$\text{At } \theta = 0, \quad F = \frac{0.15mg}{\sin 0 + 0.15 \cos 0} = 1.0mg \text{ newtons.}$$

$$\text{At } \theta = 1.422, \quad F = \frac{0.15mg}{\sin(1.422) + 0.15 \cos(1.422)} = 0.148mg \text{ newtons.}$$

$$\text{At } \theta = \pi/2, \quad F = \frac{0.15mg}{\sin(\frac{\pi}{2}) + 0.15 \cos(\frac{\pi}{2})} = 0.15mg \text{ newtons.}$$

Thus, the maximum value of F is $1.0mg$ newtons when $\theta = 0$ (her arm is vertical) and the minimum value of F is $0.148mg$ newtons is when $\theta = 1.422$ (her arm is close to horizontal). See Figure 4.38.

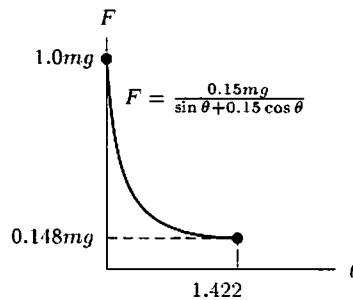

Figure 4.38

18. The domain for E is all real x . Note $E \rightarrow 0$ as $x \rightarrow \pm\infty$. The critical points occur where $dE/dx = 0$. The derivative is

$$\begin{aligned}\frac{dE}{dx} &= \frac{k}{(x^2 + r_0^2)^{3/2}} - \frac{3}{2} \cdot \frac{kx(2x)}{(x^2 + r_0^2)^{5/2}} \\ &= \frac{k(x^2 + r_0^2 - 3x^2)}{(x^2 + r_0^2)^{5/2}} \\ &= \frac{k(r_0^2 - 2x^2)}{(x^2 + r_0^2)^{3/2}}.\end{aligned}$$

So $dE/dx = 0$ where

$$\begin{aligned}r_0^2 - 2x^2 &= 0 \\ x &= \pm \frac{r_0}{\sqrt{2}}.\end{aligned}$$

Looking at the formula for dE/dx shows

$$\begin{aligned}\frac{dE}{dx} &> 0 \text{ for } -\frac{r_0}{\sqrt{2}} < x < \frac{r_0}{\sqrt{2}} \\ \frac{dE}{dx} &< 0 \text{ for } x < -\frac{r_0}{\sqrt{2}} \\ \frac{dE}{dx} &< 0 \text{ for } x > \frac{r_0}{\sqrt{2}}.\end{aligned}$$

Therefore, $x = -r_0/\sqrt{2}$ gives the minimum value of E and $x = r_0/\sqrt{2}$ gives the maximum value of E .

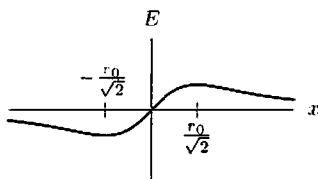

19. Since $I(t)$ is a periodic function with period $2\pi/w$, it is enough to consider $I(t)$ for $0 \leq wt \leq 2\pi$. Differentiating, we find

$$\frac{dI}{dt} = -w \sin(wt) + \sqrt{3}w \cos(wt).$$

At a critical point

$$\begin{aligned} -w \sin(wt) + \sqrt{3}w \cos(wt) &= 0 \\ \sin(wt) &= \sqrt{3} \cos(wt) \\ \tan(wt) &= \sqrt{3}. \end{aligned}$$

So $wt = \pi/3$ or $4\pi/3$, or these values plus multiples of 2π . Substituting into I , we see

$$\text{At } wt = \frac{\pi}{3}: I = \cos\left(\frac{\pi}{3}\right) + \sqrt{3}\sin\left(\frac{\pi}{3}\right) = \frac{1}{2} + \sqrt{3} \cdot \left(\frac{\sqrt{3}}{2}\right) = 2.$$

$$\text{At } wt = \frac{4\pi}{3}: I = \cos\left(\frac{4\pi}{3}\right) + \sqrt{3}\sin\left(\frac{4\pi}{3}\right) = -\frac{1}{2} - \sqrt{3} \cdot \left(\frac{\sqrt{3}}{2}\right) = -2.$$

Thus, the maximum value is 2 amps and the minimum is -2 amps.

20. (a) To show that R is an increasing function of r_1 , we show that $dR/dr_1 > 0$ for all values of r_1 . We first solve for R :

$$\begin{aligned} \frac{1}{R} &= \frac{1}{r_1} + \frac{1}{r_2} \\ \frac{1}{R} &= \frac{r_2 + r_1}{r_1 r_2} \\ R &= \frac{r_1 r_2}{r_2 + r_1}. \end{aligned}$$

We use the quotient rule (and remember that r_2 is a constant) to find dR/dr_1 :

$$\frac{dR}{dr_1} = \frac{(r_2 + r_1)(r_2) - (r_1 r_2)(1)}{(r_2 + r_1)^2} = \frac{(r_2)^2}{(r_2 + r_1)^2}.$$

Since dR/dr_1 is the square of a number, we have $dR/dr_1 > 0$ for all values of r_1 , and thus R is increasing for all r_1 .

(b) Since R is increasing on any interval $a \leq r_1 \leq b$, the maximum value of R occurs at the right endpoint $r_1 = b$.

21. Let $y = e^{-x^2}$. Since $y' = -2xe^{-x^2}$, y is increasing for $x < 0$ and decreasing for $x > 0$. Hence $y = e^0 = 1$ is a global maximum.

When $x = \pm 0.3$, $y = e^{-0.09} \approx 0.9139$, which is a global minimum on the given interval. Thus $e^{-0.09} \leq y \leq 1$ for $|x| \leq 0.3$.

22. Let $y = \ln(1+x)$. Since $y' = 1/(1+x)$, y is increasing for all $x \geq 0$. The lower bound is at $x = 0$, so, $\ln(1) = 0 \leq y$. There is no upper bound.
23. Let $y = \ln(1+x^2)$. Then $y' = 2x/(1+x^2)$. Since the denominator is always positive, the sign of y' is determined by the numerator $2x$. Thus $y' > 0$ when $x > 0$, and $y' < 0$ when $x < 0$, and we have a local (and global) minimum for y at $x = 0$. Since $y(-1) = \ln 2$ and $y(2) = \ln 5$, the global maximum is at $x = 2$. Thus $0 \leq y \leq \ln 5$, or (in decimals) $0 \leq y < 1.61$. (Note that our upper bound has been rounded up from 1.6094.)
24. Let $y = x^3 - 4x^2 + 4x$. To locate the critical points, we solve $y' = 0$. Since $y' = 3x^2 - 8x + 4 = (3x-2)(x-2)$, the critical points are $x = 2/3$ and $x = 2$. To find the global minimum and maximum on $0 \leq x \leq 4$, we check the critical points and the endpoints: $y(0) = 0$; $y(2/3) = 32/27$; $y(2) = 0$; $y(4) = 16$. Thus, the global minimum is at $x = 0$ and $x = 2$, the global maximum is at $x = 4$, and $0 \leq y \leq 16$.

25. The graph of $y = x + \sin x$ in Figure 4.39 suggests that the function is nondecreasing over the entire interval. You can confirm this by looking at the derivative:

$$y' = 1 + \cos x$$

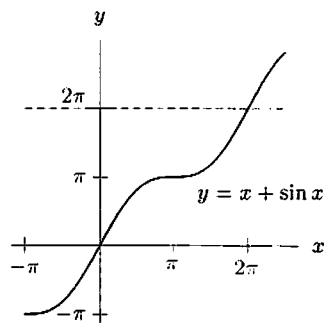

Figure 4.39: Graph of $y = x + \sin x$

Since $\cos x \geq -1$, we have $y' \geq 0$ everywhere, so y never decreases. This means that a lower bound for y is 0 (its value at the left endpoint of the interval) and an upper bound is 2π (its value at the right endpoint). That is, if $0 \leq x \leq 2\pi$:

$$0 \leq y \leq 2\pi.$$

These are the best bounds for y over the interval.

26. Examination of the graph suggests that $0 \leq x^3 e^{-x} \leq 2$. The lower bound of 0 is the best possible lower bound since

$$f(0) = (0)^3 e^{-0} = 0.$$

To find the best possible upper bound, we find the critical points. Differentiating, using the product rule, yields

$$f'(x) = 3x^2 e^{-x} - x^3 e^{-x}$$

Setting $f'(x) = 0$ and factoring gives

$$\begin{aligned} 3x^2 e^{-x} - x^3 e^{-x} &= 0 \\ x^2 e^{-x} (3 - x) &= 0 \end{aligned}$$

So the critical points are $x = 0$ and $x = 3$. Note that $f'(x) < 0$ for $x > 3$ and $f'(x) > 0$ for $x < 3$, so $f(x)$ has a local maximum at $x = 3$. Examination of the graph tells us that this is the global maximum. So $0 \leq x^3 e^{-x} \leq f(3)$.

$$f(3) = 3^3 e^{-3} \approx 1.34425$$

So $0 \leq x^3 e^{-x} \leq 3^3 e^{-3} \approx 1.34425$ are the best possible bounds for the function.

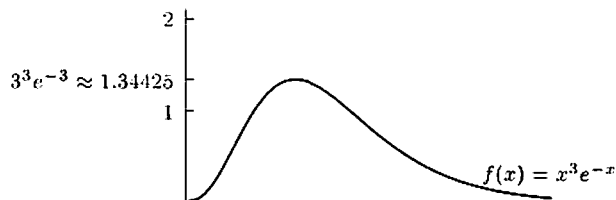

Figure 4.40

27. (a) For a point (t, s) , the line from the origin has rise = s and run = t ; See Figure 4.41. Thus, the slope of the line OP is s/t .

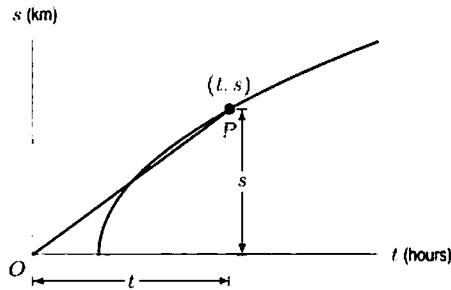
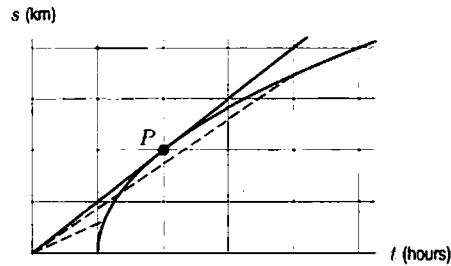

Figure 4.41

- (b) Sketching several lines from the origin to points on the curve, we see that the maximum slope occurs at the point P , where the line to the origin is tangent to the graph. Reading from the graph, we see $t \approx 2$ hours at this point.



- (c) The instantaneous speed of the cyclist at any time is given by the slope of the corresponding point on the curve. At the point P , the line from the origin is tangent to the curve, so the quantity s/t equals the cyclist's speed at the point P .
28. (a) To maximize benefit (surviving young), we pick 10, because that's the highest point of the benefit graph.
 (b) To optimize the vertical distance between the curves, we can either do it by inspection or note that the slopes of the two curves will be the same where the difference is maximized. Either way, one gets approximately 9.
29. (a) At higher speeds, more energy is used so the graph rises to the right. The initial drop is explained by the fact that the energy it takes a bird to fly at very low speeds is greater than that needed to fly at a slightly higher speed. When it flies slightly faster, the amount of energy consumed decreases. But when it flies at very high speeds, the bird consumes a lot more energy (this is analogous to our swimming in a pool).
 (b) $f(v)$ measures energy per second; $a(v)$ measures energy per meter. A bird traveling at rate v will in 1 second travel v meters, and thus will consume $v \cdot a(v)$ joules of energy in that 1 second period. Thus $v \cdot a(v)$ represents the energy consumption per second, and so $f(v) = v \cdot a(v)$.
 (c) Since $v \cdot a(v) = f(v)$, $a(v) = f(v)/v$. But this ratio has the same value as the slope of a line passing from the origin through the point $(v, f(v))$ on the curve (see figure). Thus $a(v)$ is minimal when the slope of this line is minimal. To find the value of v minimizing $a(v)$, we solve $a'(v) = 0$. By the quotient rule,

$$a'(v) = \frac{vf'(v) - f(v)}{v^2}.$$

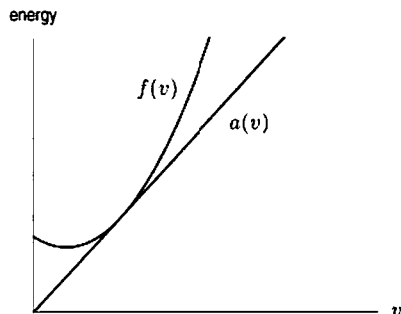

Thus $a'(v) = 0$ when $vf'(v) = f(v)$, or when $f'(v) = f(v)/v = a(v)$. Since $a(v)$ is represented by the slope of a line through the origin and a point on the curve, $a(v)$ is minimized when this line is tangent to $f(v)$, so that the slope $a(v)$ equals $f'(v)$.

- (d) The bird should minimize $a(v)$ assuming it wants to go from one particular point to another, i.e. where the distance is set. Then minimizing $a(v)$ minimizes the total energy used for the flight.
30. (a) Figure 4.42 contains the graph of total drag, plotted on the same coordinate system with induced and parasite drag. It was drawn by adding the vertical coordinates of Induced and Parasite drag.

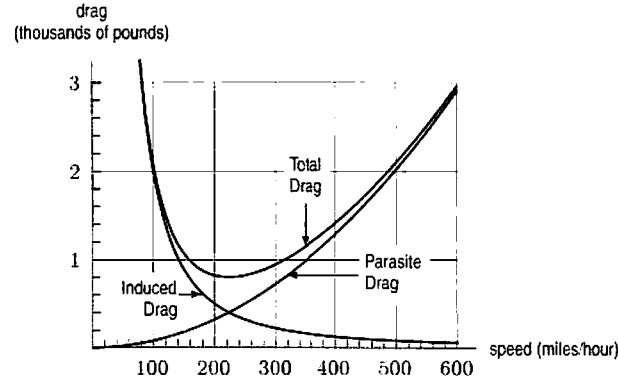

Figure 4.42

- (b) Airspeeds of approximately 160 mph and 320 mph each result in a total drag of 1000 pounds. Since two distinct airspeeds are associated with a single total drag value, the total drag function does not have an inverse. The parasite and induced drag functions do have inverses, because they are strictly increasing and strictly decreasing functions, respectively.
- (c) To conserve fuel, fly the at the airspeed which minimizes total drag. This is the airspeed corresponding to the lowest point on the total drag curve in part (a): that is, approximately 220 mph.
31. (a) To obtain $g(v)$, which is in gallons per mile, we need to divide $f(v)$ (in gallons per hour) by v (in miles per hour). Thus, $g(v) = f(v)/v$.
- (b) By inspecting the graph, we see that $f(v)$ is minimized at approximately 220 mph.
- (c) Note that a point on the graph of $f(v)$ has the coordinates $(v, f(v))$. The line passing through this point and the origin $(0, 0)$ has

$$\text{Slope} = \frac{f(v) - 0}{v - 0} = \frac{f(v)}{v} = g(v).$$

So minimizing $g(v)$ corresponds to finding the line of minimum slope from the family of lines which pass through the origin $(0, 0)$ and the point $(v, f(v))$ on the graph of $f(v)$. This line is the unique member of the family which is tangent to the graph of $f(v)$. The value of v corresponding to the point of tangency will minimize $g(v)$. This value of v will satisfy $f(v)/v = f'(v)$. From the graph in Figure 4.43, we see that $v \approx 300$ mph.

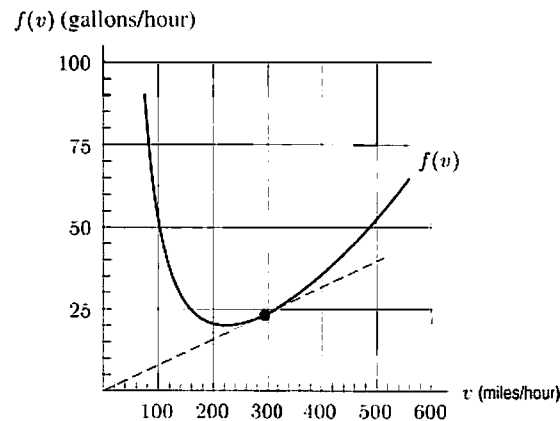
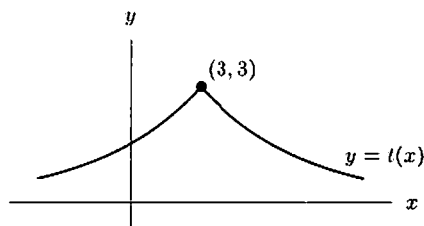
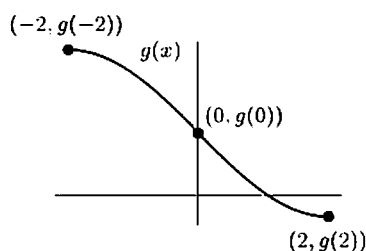

Figure 4.43

- (d) The pilot's goal with regard to $f(v)$ and $g(v)$ would depend on the purpose of the flight, and might even vary within a given flight. For example, if the mission involved aerial surveillance or banner-towing over some limited area, or if the plane was flying a holding pattern, then the pilot would want to minimize $f(v)$ so as to remain aloft as long as possible. In a more normal situation where the purpose was economical travel between two fixed points, then the minimum net fuel expenditure for the trip would result from minimizing $g(v)$.
32. Since the function is positive, the graph lies above the x -axis. If there is a global maximum at $x = 3$, $t'(x)$ must be positive, then negative. Since $t'(x)$ and $t''(x)$ have the same sign for $x < 3$, they must both be positive, and thus the graph must be increasing and concave up. Since $t'(x)$ and $t''(x)$ have opposite signs for $x > 3$ and $t'(x)$ is negative, $t''(x)$ must again be positive and the graph must be decreasing and concave up. A possible sketch of $y = t(x)$ is shown in the figure below.



33. Here is one possible graph of g :



- (a) From left to right, the graph of $g(x)$ starts "flat", decreases slowly at first then more rapidly, most rapidly at $x = 0$. The graph then continues to decrease but less and less rapidly until flat again at $x = 2$. The graph should exhibit symmetry about the point $(0, g(0))$.
- (b) The graph has an inflection point at $(0, g(0))$ where the slope changes from negative and decreasing to negative and increasing.
- (c) The function has a global maximum at $x = -2$ and a global minimum at $x = 2$.
- (d) Since the function is decreasing over the interval $-2 \leq x \leq 2$

$$g(-2) = 5 > g(0) > g(2).$$

Since the function appears symmetric about $(0, g(0))$, we have

$$g(-2) - g(0) = g(0) - g(2).$$

34. (a) We want to find where $x > 2 \ln x$, which is the same as solving $x - 2 \ln x > 0$. Let $f(x) = x - 2 \ln x$. Then $f'(x) = 1 - \frac{2}{x}$, which implies that $x = 2$ is the only critical point of f . Since $f'(x) < 0$ for $x < 2$ and $f'(x) > 0$ for $x > 2$, by the first derivative test we see that f has a local and global minimum at $x = 2$. Since $f(2) = 2 - 2 \ln 2 \approx 0.61$, then for all $x > 0$, $f(x) \geq f(2) > 0$. Thus $f(x)$ is always positive, which means $x > 2 \ln x$ for any $x > 0$.
- (b) We've shown that $x > 2 \ln x = \ln(x^2)$ for all $x > 0$. Since e^x is an increasing function, $e^x > e^{\ln x^2} = x^2$, so $e^x > x^2$ for all $x > 0$.
- (c) Let $f(x) = x - 3 \ln x$. Then $f'(x) = 1 - \frac{3}{x} = 0$ at $x = 3$. By the first derivative test, f has a local minimum at $x = 3$. But, $f(3) \approx -0.295$, which is less than zero. Thus $3 \ln x > x$ at $x = 3$. So, x is not less than $3 \ln x$ for all $x > 0$.

(One could also see this by substituting $x = e$: since $3 \ln e = 3$, $x < 3 \ln x$ when $x = e$.)

Solutions for Section 4.4

Exercises

- The fixed costs are \$5000, the marginal cost per item is \$2.40, and the price per item is \$4.
- (a) Total cost, in millions of dollars, $C(q) = 3 + 0.4q$.
 (b) Revenue, in millions of dollars, $R(q) = 0.5q$.
 (c) Profit, in millions of dollars, $\pi(q) = R(q) - C(q) = 0.5q - (3 + 0.4q) = 0.1q - 3$.
- The profit $\pi(q)$ is given by

$$\pi(q) = R(q) - C(q) = 500q - q^2 - (150 + 10q) = 490q - q^2 - 150.$$

The maximum profit occurs when

$$\pi'(q) = 490 - 2q = 0 \quad \text{so} \quad q = 245 \text{ items.}$$

Since $\pi''(q) = -2$, this critical point is a maximum. Alternatively, we obtain the same result from the fact that the graph of π is a parabola opening downward.

- Since for $q = 500$, we have $MC(500) = C'(500) = 75$ and $MR(500) = R'(500) = 100$, so $MR(500) > MC(500)$. Thus, increasing production from $q = 500$ increases profit.
- Since fixed costs are represented by the vertical intercept, they are \$1.1 million. The quantity that maximizes profit is about $q = 70$, and the profit achieved is $\$(3.7 - 2.5) = \1.2 million

Problems

6.

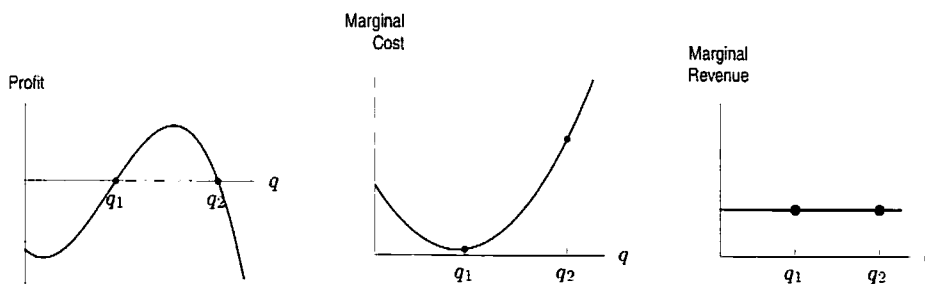

- (a) $\pi(q)$ is maximized when $R(q) > C(q)$ and they are as far apart as possible:

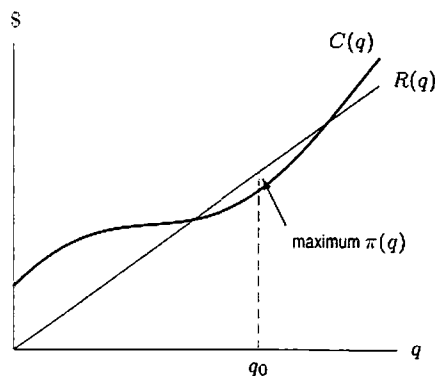

- (b) $\pi'(q_0) = R'(q_0) - C'(q_0) = 0$ implies that $C'(q_0) = R'(q_0) = p$.

Graphically, the slopes of the two curves at q_0 are equal. This is plausible because if $C'(q_0)$ were greater than p or less than p , the maximum of $\pi(q)$ would be to the left or right of q_0 , respectively. In economic terms, if the cost were rising more quickly than revenues, the profit would be maximized at a lower quantity (and if the cost were rising more slowly, at a higher quantity).

(c)

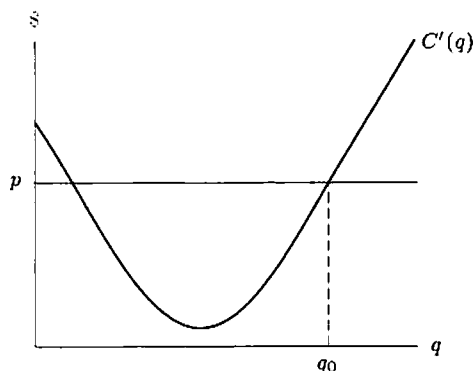

8. (a) The value of $C(0)$ represents the fixed costs before production, that is, the cost of producing zero units, incurred for initial investments in equipment, and so on.
- (b) The marginal cost decreases slowly, and then increases as quantity produced increases. See Problem 6, graph (b).
- (c) Concave down implies decreasing marginal cost, while concave up implies increasing marginal cost.
- (d) An inflection point of the cost function is (locally) the point of maximum or minimum marginal cost.
- (e) One would think that the more of an item you produce, the less it would cost to produce extra items. In economic terms, one would expect the marginal cost of production to decrease, so we would expect the cost curve to be concave down. In practice, though, it eventually becomes more expensive to produce more items, because workers and resources may become scarce as you increase production. Hence after a certain point, the marginal cost may rise again. This happens in oil production, for example.
9. (a) We know that Profit = Revenue – Cost, so differentiating with respect to q gives:

$$\text{Marginal Profit} = \text{Marginal Revenue} - \text{Marginal Cost.}$$

We see from the figure in the problem that just to the left of $q = a$, marginal revenue is less than marginal cost, so marginal profit is negative there. To the right of $q = a$ marginal revenue is greater than marginal cost, so marginal profit is positive there. At $q = a$ marginal profit changes from negative to positive. This means that profit is decreasing to the left of a and increasing to the right. The point $q = a$ corresponds to a local minimum of profit, and does not maximize profit. It would be a terrible idea for the company to set its production level at $q = a$.

- (b) We see from the figure in the problem that just to the left of $q = b$ marginal revenue is greater than marginal cost, so marginal profit is positive there. Just to the right of $q = b$ marginal revenue is less than marginal cost, so marginal profit is negative there. At $q = b$ marginal profit changes from positive to negative. This means that profit is increasing to the left of b and decreasing to the right. The point $q = b$ corresponds to a local maximum of profit. In fact, since the area between the MC and MR curves in the figure in the text between $q = a$ and $q = b$ is bigger than the area between $q = 0$ and $q = a$, $q = b$ is in fact a global maximum.
10. (a) The fixed cost is 0 because $C(0) = 0$.
- (b) Profit, $\pi(q)$, is equal to money from sales, $7q$, minus total cost to produce those items, $C(q)$.

$$\pi = 7q - 0.01q^3 + 0.6q^2 - 13q$$

$$\pi' = -0.03q^2 + 1.2q - 6$$

$$\pi' = 0 \quad \text{if} \quad q = \frac{-1.2 \pm \sqrt{(1.2)^2 - 4(0.03)(6)}}{-0.06} \approx 5.9 \quad \text{or} \quad 34.1.$$

Now $\pi'' = -0.06q + 1.2$, so $\pi''(5.9) > 0$ and $\pi''(34.1) < 0$. This means $q = 5.9$ is a local min and $q = 34.1$ a local max. We now evaluate the endpoint, $\pi(0) = 0$, and the points nearest $q = 34.1$ with integer q -values:

$$\pi(35) = 7(35) - 0.01(35)^3 + 0.6(35)^2 - 13(35) = 245 - 148.75 = 96.25,$$

$$\pi(34) = 7(34) - 0.01(34)^3 + 0.6(34)^2 - 13(34) = 238 - 141.44 = 96.56.$$

So the (global) maximum profit is $\pi(34) = 96.56$. The money from sales is \$238, the cost to produce the items is \$141.44, resulting in a profit of \$96.56.

- (c) The money from sales is equal to price \times quantity sold. If the price is raised from \$7 by \$ x to \$(7 + x), the result is a reduction in sales from 34 items to (34 - 2 x) items. So the result of raising the price by \$ x is to change the money from sales from (7)(34) to (7 + x)(34 - 2 x) dollars. If the production level is fixed at 34, then the production costs are fixed at \$141.44, as found in part (b), and the profit is given by:

$$\pi(x) = (7 + x)(34 - 2x) - 141.44$$

This expression gives the profit as a function of change in price x , rather than as a function of quantity as in part (b). We set the derivative of π with respect to x equal to zero to find the change in price that maximizes the profit:

$$\frac{d\pi}{dx} = (1)(34 - 2x) + (7 + x)(-2) = 20 - 4x = 0$$

So $x = 5$, and this must give a maximum for $\pi(x)$ since the graph of π is a parabola which opens downwards. The profit when the price is \$12 ($= 7 + x = 7 + 5$) is thus $\pi(5) = (7 + 5)(34 - 2(5)) - 141.44 = \146.56 . This is indeed higher than the profit when the price is \$7, so the smart thing to do is to raise the price by \$5.

11. (a) Say n passengers sign up for the cruise. If $n \leq 100$, then the cruise's revenue is $R = 1000n$, and so the maximum revenue if $n \leq 100$ is $R = 1000 \cdot 100 = 100,000$. If $n \geq 100$, then the price is

$$p = 1000 - 5(n - 100)$$

and hence revenue is

$$R = n(1000 - 5(n - 100)) = 1500n - 5n^2.$$

To find the maximum of this, we set $dR/dn = 0$, or $10n = 1500$, or $n = 150$, yielding revenue of $(1000 - 5 \cdot 50) \cdot 150 = 112,500$. Since this is more than the maximum revenue when $n \leq 100$, we see that the boat maximizes its revenue with 150 passengers, each paying \$750.

- (b) We approach this problem in a similar way to part (a), except now we are dealing with the profit function π . If $n \leq 100$, we have that $\pi = 1000n - 40,000 - 200n$, and thus π would be maximized with 100 passengers yielding a profit of $\pi = 800 \cdot 100 - 40,000 = \$40,000$. If $n > 100$, we have the formula $\pi = n(1000 - 5(n - 100)) - (40,000 + 200n)$. We again wish to set $d\pi/dn = 0$, or $1300 = 10n$, or $n = 130$, yielding profit of \$44,500. So the boat will maximize profit by boarding 130 passengers, each paying \$850. This gives the boat \$44,500 in profit.

12. For each month,

$$\text{Profit} = \text{Revenue} - \text{Cost}$$

$$\pi = pq - wL = pcK^\alpha L^\beta - wL$$

The variable on the right is L , so at the maximum

$$\frac{d\pi}{dL} = \beta pcK^\alpha L^{\beta-1} - w = 0$$

Now $\beta - 1$ is negative, since $0 < \beta < 1$, so $1 - \beta$ is positive and we can write

$$\frac{\beta pcK^\alpha}{L^{1-\beta}} = w$$

giving

$$L = \left(\frac{\beta pcK^\alpha}{w} \right)^{\frac{1}{1-\beta}}$$

Since $\beta - 1$ is negative, when L is just above 0, the quantity $L^{\beta-1}$ is huge and positive, so $d\pi/dL > 0$. When L is large, $L^{\beta-1}$ is small, so $d\pi/dL < 0$. Thus the value of L we have found gives a global maximum, since it is the only critical point.

13. (a) $N = 100 + 20x$, graphed in Figure 4.44.

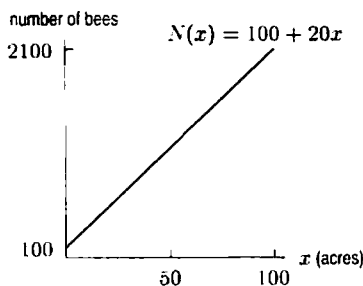

Figure 4.44

- (b) $N'(x) = 20$ and its graph is just a horizontal line. This means that rate of increase of the number of bees with acres of clover is constant — each acre of clover brings 20 more bees.

On the other hand, $N(x)/x = 100/x + 20$ means that the average number of bees per acre of clover approaches 20 as more acres are put under clover. See Figure 4.45. As x increases, $100/x$ decreases to 0, so $N(x)/x$ approaches 20 (i.e. $N(x)/x \rightarrow 20$). Since the total number of bees is 20 per acre plus the original 100, the average number of bees per acre is 20 plus the 100 shared out over x acres. As x increases, the 100 are shared out over more acres, and so its contribution to the average becomes less. Thus the average number of bees per acre approaches 20 for large x .

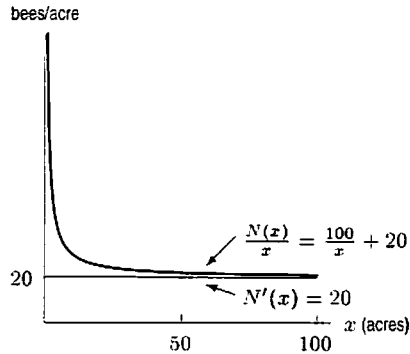

Figure 4.45

14. This question implies that the line from the origin to the point $(x, R(x))$ has some relationship to $r(x)$. The slope of this line is $R(x)/x$, which is $r(x)$. So the point x_0 at which $r(x)$ is maximal will also be the point at which the slope of this line is maximal. The question claims that the line from the origin to $(x_0, R(x_0))$ will be tangent to the graph of $R(x)$. We can understand this by trying to see what would happen if it were otherwise.

If the line from the origin to $(x_0, R(x_0))$ intersects the graph of $R(x)$, but is not tangent to the graph of $R(x)$ at x_0 , then there are points of this graph on both sides of the line — and, in particular, there is some point x_1 such that the line from the origin to $(x_1, R(x_1))$ has larger slope than the line to $(x_0, R(x_0))$. (See the graph below.) But we picked x_0 so that no other line had larger slope, and therefore no such x_1 exists. So the original supposition is false, and the line from the origin to $(x_0, R(x_0))$ is tangent to the graph of $R(x)$.

(a) See (b).

(b)

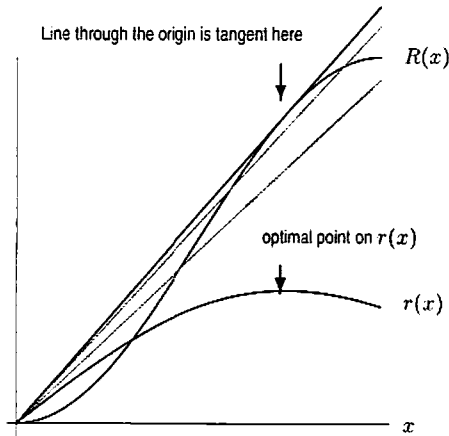

(c)

$$r(x) = \frac{R(x)}{x}$$

$$r'(x) = \frac{xR'(x) - R(x)}{x^2}$$

So when $r(x)$ is maximized $0 = xR'(x) - R(x)$, the numerator of $r'(x)$, or $R'(x) = R(x)/x = r(x)$. i.e. when $r(x)$ is maximized, $r(x) = R'(x)$.

Let us call the x -value at which the maximum of r occurs x_m . Then the line passing through $R(x_m)$ and the origin is $y = x \cdot R(x_m)/x_m$. Its slope is $R(x_m)/x_m$, which also happens to be $r(x_m)$. In the previous paragraph, we showed that at x_m , this is also equal to the slope of the tangent to $R(x)$. So, the line through the origin is the tangent line.

15. (a) The value of MC is the slope of the tangent to the curve at q_0 . See Figure 4.46.
 (b) The line from the curve to the origin joins $(0, 0)$ and $(q_0, C(q_0))$, so its slope is $C(q_0)/q_0 = a(q_0)$.
 (c) Figure 4.47 shows that the line whose slope is the minimum $a(q)$ is tangent to the curve $C(q)$. This line, therefore, also has slope MC , so $a(q) = MC$ at the q making $a(q)$ minimum.

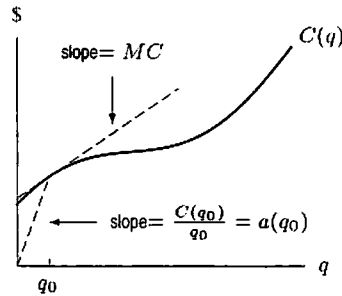

Figure 4.46

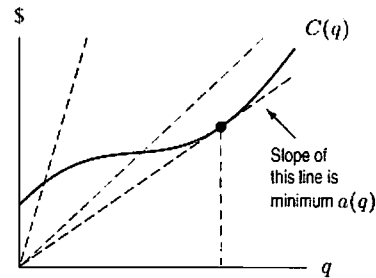

Figure 4.47

16. (a) $a(q) = C(q)/q$, so $C(q) = 0.01q^3 - 0.6q^2 + 13q$.
 (b) Taking the derivative of $C(q)$ gives an expression for the marginal cost:

$$C'(q) = MC(q) = 0.03q^2 - 1.2q + 13.$$

To find the smallest MC we take its derivative and find the value of q that makes it zero. So: $MC'(q) = 0.06q - 1.2 = 0$ when $q = 1.2/0.06 = 20$. This value of q must give a minimum because the graph of $MC(q)$ is a parabola opening upwards. Therefore the minimum marginal cost is $MC(20) = 1$. So the marginal cost is at a minimum when the additional cost per item is \$1.

- (c) $a'(q) = 0.02q - 0.6$
 Setting $a'(q) = 0$ and solving for q gives $q = 30$ as the quantity at which the average is minimized, since the graph of a is a parabola which opens upwards. The minimum average cost is $a(30) = 4$ dollars per item.
 (d) The marginal cost at $q = 30$ is $MC(30) = 0.03(30)^2 - 1.2(30) + 13 = 4$. This is the same as the average cost at this quantity. Note that since $a(q) = C(q)/q$, we have $a'(q) = (qC'(q) - C(q))/q^2$. At a critical point, q_0 , of $a(q)$, we have

$$0 = a'(q_0) = \frac{q_0 C'(q_0) - C(q_0)}{q_0^2},$$

so $C'(q_0) = C(q_0)/q_0 = a(q_0)$. Therefore $C'(30) = a(30) = 4$ dollars per item.

Another way to see why the marginal cost at $q = 30$ must equal the minimum average cost $a(30) = 4$ is to view $C'(30)$ as the approximate cost of producing the 30th or 31st good. If $C'(30) < a(30)$, then producing the 31st good would lower the average cost, i.e. $a(31) < a(30)$. If $C'(30) > a(30)$, then producing the 30th good would raise the average cost, i.e. $a(30) > a(29)$. Since $a(30)$ is the global minimum, we must have $C'(30) = a(30)$.

17. (a) Differentiating $C(q)$ gives

$$C'(q) = \frac{K}{a} q^{(1/a)-1}, \quad C''(q) = \frac{K}{a} \left(\frac{1}{a} - 1 \right) q^{(1/a)-2}.$$

If $a > 1$, then $C''(q) < 0$, so C is concave down.

- (b) We have

$$a(q) = \frac{C(q)}{q} = \frac{Kq^{1/a} + F}{q}$$

$$C'(q) = \frac{K}{a} q^{(1/a)-1}$$

so $a(q) = C'(q)$ means

$$\frac{Kq^{1/a} + F}{q} = \frac{K}{a}q^{(1/a)-1}.$$

Solving,

$$\begin{aligned} Kq^{1/a} + F &= \frac{K}{a}q^{1/a} \\ K\left(\frac{1}{a} - 1\right)q^{1/a} &= F \\ q &= \left[\frac{Fa}{K(1-a)}\right]^a. \end{aligned}$$

Solutions for Section 4.5

Exercises

1. We take the derivative, set it equal to 0, and solve for x :

$$\begin{aligned} \frac{dt}{dx} &= \frac{1}{6} - \frac{1}{4} \cdot \frac{1}{2} \left((2000 - x)^2 + 600^2 \right)^{-1/2} \cdot 2(2000 - x) = 0 \\ (2000 - x) &= \frac{2}{3} \left((2000 - x)^2 + 600^2 \right)^{1/2} \\ (2000 - x)^2 &= \frac{4}{9} \left((2000 - x)^2 + 600^2 \right) \\ \frac{5}{9}(2000 - x)^2 &= \frac{4}{9} \cdot 600^2 \\ 2000 - x &= \sqrt{\frac{4}{5} \cdot 600^2} = \frac{1200}{\sqrt{5}} \\ x &= 2000 - \frac{1200}{\sqrt{5}} \text{ feet.} \end{aligned}$$

Note that $2000 - (1200/\sqrt{5}) \approx 1463$ feet, as given in the example.

2. Call the stacks A and B. (See below.) Assume that A corresponds to k_1 , and B corresponds to k_2 .

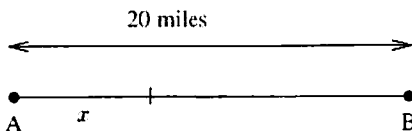

Suppose the point where the concentration of deposit is a minimum occurs at a distance of x miles from stack A. We want to find x such that

$$S = \frac{k_1}{x^2} + \frac{k_2}{(20-x)^2} = k_2 \left(\frac{7}{x^2} + \frac{1}{(20-x)^2} \right)$$

is a minimum, which is the same thing as minimizing $f(x) = 7x^{-2} + (20-x)^{-2}$ since k_2 is nonnegative.

We have

$$f'(x) = -14x^{-3} - 2(20-x)^{-3}(-1) = \frac{-14}{x^3} + \frac{2}{(20-x)^3} = \frac{-14(20-x)^3 + 2x^3}{x^3(20-x)^3}.$$

Thus we want to find x such that $-14(20-x)^3 + 2x^3 = 0$, which implies $2x^3 = 14(20-x)^3$. That's equivalent to $x^3 = 7(20-x)^3$, or $\frac{20-x}{x} = (1/7)^{1/3} \approx 0.523$. Solving for x , we have $20-x = 0.523x$, whence $x = 20/1.523 \approx 13.13$.

To verify that this minimizes f , we take the second derivative:

$$f''(x) = 42x^{-4} + 6(20-x)^{-4} = \frac{42}{x^4} + \frac{6}{(20-x)^4} > 0$$

for any $0 < x < 20$, so by the second derivative test the concentration is minimized 13.13 miles from A.

3. We only consider $\lambda > 0$. For such λ , the value of $v \rightarrow \infty$ as $\lambda \rightarrow \infty$ and as $\lambda \rightarrow 0^+$. Thus, v does not have a maximum velocity. It will have a minimum velocity. To find it, we set $dv/d\lambda = 0$:

$$\frac{dv}{d\lambda} = k \frac{1}{2} \left(\frac{\lambda}{c} + \frac{c}{\lambda} \right)^{-1/2} \left(\frac{1}{c} - \frac{c}{\lambda^2} \right) = 0.$$

Solving, and remembering that $\lambda > 0$, we obtain

$$\begin{aligned} \frac{1}{c} - \frac{c}{\lambda^2} &= 0 \\ \frac{1}{c} &= \frac{c}{\lambda^2} \\ \lambda^2 &= c^2, \end{aligned}$$

so

$$\lambda = c.$$

Thus, we have one critical point. Since

$$\frac{dv}{d\lambda} < 0 \quad \text{for } \lambda < c$$

and

$$\frac{dv}{d\lambda} > 0 \quad \text{for } \lambda > c,$$

the first derivative test tells us that we have a local minimum of v at $x = c$. Since $\lambda = c$ is the only critical point, it gives the global minimum. Thus the minimum value of v is

$$v = k \sqrt{\frac{c}{c} + \frac{c}{c}} = \sqrt{2}k.$$

Problems

4. We wish to choose a to maximize the area of the rectangle with corners at (a, \sqrt{a}) and $(9, \sqrt{a})$. The area of this rectangle will be given by the formula

$$R = h \cdot l = \sqrt{a}(9 - a) = 9a^{1/2} - a^{3/2}.$$

We are restricted to $0 \leq a \leq 9$. To maximize this area, we set $dR/da = 0$, and then check that the resulting area is greater than the area if $a = 0$ or $a = 9$. Since $R = 0$ if $a = 0$ or $a = 9$, all we need to do is to find where $dR/da = 0$:

$$\begin{aligned} \frac{dR}{da} &= \frac{9}{2}a^{-1/2} - \frac{3}{2}a^{1/2} = 0 \\ \frac{9}{2\sqrt{a}} &= \frac{3\sqrt{a}}{2} \\ 18 &= 6a \\ a &= 3. \end{aligned}$$

Thus, the dimensions of the maximal rectangle are 6 by $\sqrt{3}$.

5. (a) Suppose the height of the box is h . The box has six sides, four with area xh and two, the top and bottom, with area x^2 . Thus,

$$4xh + 2x^2 = A.$$

So

$$h = \frac{A - 2x^2}{4x}.$$

Then, the volume, V , is given by

$$\begin{aligned} V &= x^2h = x^2 \left(\frac{A - 2x^2}{4x} \right) = \frac{x}{4} (A - 2x^2) \\ &= \frac{A}{4}x - \frac{1}{2}x^3. \end{aligned}$$

- (b) The graph is shown in Figure 4.48. We are assuming A is a positive constant. Also, we have drawn the whole graph, but we should only consider $V > 0$, $x > 0$ as V and x are lengths.

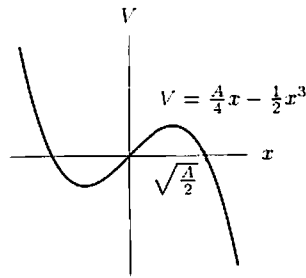

Figure 4.48

- (c) To find the maximum, we differentiate, regarding A as a constant:

$$\frac{dV}{dx} = \frac{A}{4} - \frac{3}{2}x^2.$$

So $dV/dx = 0$ if

$$\begin{aligned} \frac{A}{4} - \frac{3}{2}x^2 &= 0 \\ x &= \pm \sqrt{\frac{A}{6}}. \end{aligned}$$

For a real box, we must use $x = \sqrt{A/6}$. Figure 4.48 makes it clear that this value of x gives the maximum. Evaluating at $x = \sqrt{A/6}$, we get

$$V = \frac{A}{4} \sqrt{\frac{A}{6}} - \frac{1}{2} \left(\sqrt{\frac{A}{6}} \right)^3 = \frac{A}{4} \sqrt{\frac{A}{6}} - \frac{1}{2} \cdot \frac{A}{6} \sqrt{\frac{A}{6}} = \left(\frac{A}{6} \right)^{3/2}.$$

6. Let w and l be the width and length, respectively, of the rectangular area you wish to enclose. Then

$$\begin{aligned} w + w + l &= 100 \text{ feet} \\ l &= 100 - 2w \\ \text{Area} = w \cdot l &= w(100 - 2w) = 100w - 2w^2 \end{aligned}$$

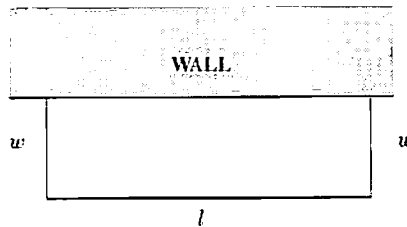

To maximize area, we solve $A' = 0$ to find critical points. This gives $A' = 100 - 4w = 0$, so $w = 25$, $l = 50$. So the area is $25 \cdot 50 = 1250$ square feet. This is a local maximum by the second derivative test because $A'' = -4 < 0$. Since the graph of A is a parabola, the local maximum is in fact a global maximum.

7. From the triangle shown in Figure 4.49, we see that

$$\begin{aligned} \left(\frac{w}{2} \right)^2 + \left(\frac{h}{2} \right)^2 &= 30^2 \\ w^2 + h^2 &= 4(30)^2 = 3600. \end{aligned}$$

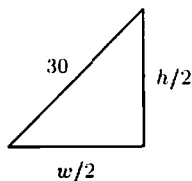

Figure 4.49

The strength, S , of the beam is given by

$$S = kh^2,$$

for some constant k . To make S a function of only one variable, substitute for h^2 , giving

$$S = kw(3600 - w^2) = k(3600w - w^3).$$

Differentiating and setting $dS/dw = 0$,

$$\frac{dS}{dw} = k(3600 - 3w^2) = 0.$$

Solving for w gives

$$w = \sqrt{1200} = 34.64 \text{ cm.}$$

so

$$h^2 = 3600 - w^2 = 3600 - 1200 = 2400$$

$$h = \sqrt{2400} = 48.99 \text{ cm.}$$

Thus, $w = 34.64$ cm and $h = 48.99$ cm give a critical point. To check that this is a local maximum, we compute

$$\frac{d^2S}{dw^2} = -6w < 0 \quad \text{for } w > 0.$$

Since $d^2S/dw^2 < 0$, we see that $w = 34.64$ cm is a local maximum. It is the only critical point, so it is a global maximum.

8. Consider the rectangle of sides x and y shown in the figure below.



The total area is $xy = 3000$, so $y = 3000/x$. Suppose the left and right edges and the lower edge have the shrubs and the top edge has the fencing. The total cost is

$$\begin{aligned} C &= 25(x + 2y) + 10(x) \\ &= 35x + 50y. \end{aligned}$$

Since $y = 3000/x$, this reduces to

$$C(x) = 35x + 50(3000/x) = 35x + 150,000/x.$$

Therefore, $C'(x) = 35 - 150,000/x^2$. We set this to 0 to find the critical points:

$$\begin{aligned} 35 - \frac{150,000}{x^2} &= 0 \\ \frac{150,000}{x^2} &= 35 \\ x^2 &= 4285.71 \\ x &\approx 65.5 \text{ ft} \end{aligned}$$

so that

$$y = 3000/x \approx 45.8 \text{ ft.}$$

Since $C(x) \rightarrow \infty$ as $x \rightarrow 0^+$ and $x \rightarrow \infty$, $x = 65.5$ is a minimum. The minimum total cost is then

$$C(65.5) \approx \$4583.$$

9. Figure 4.50 shows the the pool has dimensions x by y and the deck extends 5 feet at either side and 10 feet at the ends of the pool.

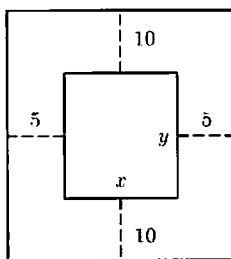

Figure 4.50

The dimensions of the plot of land containing the pool are then $(x + 5 + 5)$ by $(y + 10 + 10)$. The area of the land is then

$$A = (x + 10)(y + 20),$$

which is to be minimized. We also are told that the area of the pool is $xy = 1800$, so

$$y = 1800/x$$

and

$$\begin{aligned} A &= (x + 10) \left(\frac{1800}{x} + 20 \right) \\ &= 1800 + 20x + \frac{18000}{x} + 200. \end{aligned}$$

We find dA/dx and set it to zero to get

$$\begin{aligned} \frac{dA}{dx} &= 20 - \frac{18000}{x^2} = 0 \\ 20x^2 &= 18000 \\ x^2 &= 900 \\ x &= 30 \text{ feet.} \end{aligned}$$

Since $A \rightarrow \infty$ as $x \rightarrow 0^+$ and as $x \rightarrow \infty$, this critical point must be a global minimum. Also, $y = 1800/30 = 60$ feet. The plot of land is therefore $(30 + 10) = 40$ by $(60 + 20) = 80$ feet.

10. Volume: $V = x^2y$,

$$\text{Surface: } S = x^2 + 4xy = x^2 + 4xV/x^2 = x^2 + 4V/x.$$

To find the dimensions which minimize the area, find x such that $dS/dx = 0$.

$$\frac{dS}{dx} = 2x - \frac{4V}{x^2} = 0.$$

so

$$x^3 = 2V,$$

and solving for x gives $x = \sqrt[3]{2V}$. To see that this gives a minimum, note that for small x , $S \approx 4V/x$ is decreasing. For large x , $S \approx x^2$ is increasing. Since there is only one critical point, this must give a global minimum. Using x to find y gives $y = V/x^2 = V/(2V)^{2/3} = \sqrt[3]{V/4}$.

11. If the illumination is represented by I , then we know that

$$I = \frac{k \cos \theta}{r^2}.$$

See Figure 4.51.

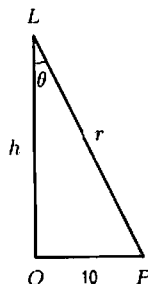

Figure 4.51

Since $r^2 = h^2 + 10^2$ and $\cos \theta = h/r = h/\sqrt{h^2 + 10^2}$, we have

$$I = \frac{kh}{(h^2 + 10^2)^{3/2}}.$$

To find the height at which I is maximized, we differentiate

$$\frac{dI}{dh} = \frac{k}{(h^2 + 10^2)^{3/2}} - \frac{3kh(2h)}{2(h^2 + 10^2)^{5/2}} = \frac{k(h^2 + 10^2) - 3kh^2}{(h^2 + 10^2)^{5/2}} = \frac{k(10^2 - 2h^2)}{(h^2 + 10^2)^{5/2}}.$$

Setting $dI/dh = 0$ gives

$$10^2 - 2h^2 = 0 \\ h = \sqrt{50} \text{ meters.}$$

Since $dI/dh > 0$ for $0 \leq h < \sqrt{50}$ and $dI/dh < 0$ for $h > \sqrt{50}$, we know that I is a maximum when $h = \sqrt{50}$ meters.

12. The distance from a given point on the parabola (x, x^2) to $(1, 0)$ is given by

$$D = \sqrt{(x-1)^2 + (x^2-0)^2}.$$

Minimizing this is equivalent to minimizing $d = (x-1)^2 + x^4$. (We can ignore the square root if we are only interested in minimizing because the square root is smallest when the thing it is the square root of is smallest.) To minimize d , we find its critical points by solving $d' = 0$. Since $d = (x-1)^2 + x^4 = x^2 - 2x + 1 + x^4$,

$$d' = 2x - 2 + 4x^3 = 2(2x^3 + x - 1).$$

By graphing $d' = 2(2x^3 + x - 1)$ on a calculator, we see that it has only 1 root, $x \approx 0.59$. This must give a minimum because $d \rightarrow \infty$ as $x \rightarrow -\infty$ and as $x \rightarrow +\infty$, and d has only one critical point. This is confirmed by the second derivative test: $d'' = 12x^2 + 2 = 2(6x^2 + 1)$, which is always positive. Thus the point $(0.59, 0.59^2) \approx (0.59, 0.35)$ is approximately the closest point of $y = x^2$ to $(1, 0)$.

13. Any point on the curve can be written (x, x^2) . The distance between such a point and $(3, 0)$ is given by

$$s(x) = \sqrt{(3-x)^2 + (0-x^2)^2} = \sqrt{(3-x)^2 + x^4}.$$

Plotting this function in Figure 4.52, we see that there is a minimum near $x = 1$.

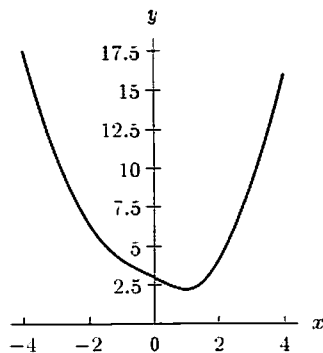

Figure 4.52

To find the value of x that minimizes the distance we can instead minimize the function $Q = s^2$ (the derivative is simpler). Then we have

$$Q(x) = (3 - x)^2 + x^4.$$

Differentiating $Q(x)$ gives

$$\frac{dQ}{dx} = -6 + 2x + 4x^3.$$

Plotting the function $4x^3 + 2x - 6$ shows that there is one real solution at $x = 1$, which can be verified by substitution; the required coordinates are therefore $(1, 1)$. Because $Q''(x) = 2 + 12x^2$ is always positive, $x = 1$ is indeed the minimum. See Figure 4.53.

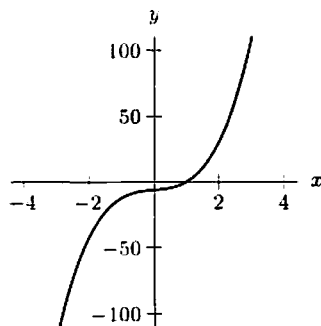

Figure 4.53

14. We see that the width of the tunnel is $2r$. The area of the rectangle is then $(2r)h$. The area of the semicircle is $(\pi r^2)/2$. The cross-sectional area, A , is then

$$A = 2rh + \frac{1}{2}\pi r^2$$

and the perimeter, P , is

$$P = 2h + 2r + \pi r.$$

From $A = 2rh + (\pi r^2)/2$ we get

$$h = \frac{A}{2r} - \frac{\pi r}{4}.$$

Thus,

$$P = 2\left(\frac{A}{2r} - \frac{\pi r}{4}\right) + 2r + \pi r = \frac{A}{r} + 2r + \frac{\pi r}{2}.$$

We now have the perimeter in terms of r and the constant A . Differentiating, we obtain

$$\frac{dP}{dr} = -\frac{A}{r^2} + 2 + \frac{\pi}{2}.$$

To find the critical points we set $P' = 0$:

$$\begin{aligned} -\frac{A}{r^2} + \frac{\pi}{2} + 2 &= 0 \\ \frac{r^2}{A} &= \frac{2}{4 + \pi} \\ r &= \sqrt{\frac{2A}{4 + \pi}}. \end{aligned}$$

Substituting this back into our expression for h , we have

$$h = \frac{A}{2} \cdot \frac{\sqrt{4 + \pi}}{\sqrt{2A}} - \frac{\pi}{4} \cdot \frac{\sqrt{2A}}{\sqrt{4 + \pi}}.$$

Since $P \rightarrow \infty$ as $r \rightarrow 0^+$ and as $r \rightarrow \infty$, this critical point must be a global minimum. Notice that the h -value simplifies to

$$h = \sqrt{\frac{2A}{4 + \pi}} = r.$$

15. Let the sides of the rectangle have lengths a and b . We shall look for the minimum of the square s of the length of either diagonal, i.e. $s = a^2 + b^2$. The area is $A = ab$, so $b = A/a$. This gives

$$s(a) = a^2 + \frac{A^2}{a^2}.$$

To find the minimum squared length we need to find the critical points of s . Differentiating s with respect to a gives

$$\frac{ds}{da} = 2a + (-2)A^2a^{-3} = 2a \left(1 - \frac{A^2}{a^4} \right)$$

The derivative $ds/da = 0$ when $a = \sqrt{A}$, that is when $a = b$ and so the rectangle is a square. Because $\frac{d^2s}{da^2} = 2 \left(1 + \frac{3A^2}{a^4} \right) > 0$, this is a minimum.

16. Let x equal the number of chairs ordered in excess of 300, so $0 \leq x \leq 100$.

$$\begin{aligned} \text{Revenue} = R &= (90 - 0.25x)(300 + x) \\ &= 27,000 - 75x + 90x - 0.25x^2 = 27,000 + 15x - 0.25x^2 \end{aligned}$$

At a critical point $dR/dx = 0$. Since $dR/dx = 15 - 0.5x$, we have $x = 30$, and the maximum revenue is \$27,225 since the graph of R is a parabola which opens downwards. The minimum is \$0 (when no chairs are sold).

17. If v is the speed of the boat in miles per hour, then

$$\text{Cost of fuel per hour (in \$/hour)} = kv^3.$$

where k is the constant of proportionality. To find k , use the information that the boat uses \$100 worth of fuel per hour when cruising at 10 miles per hour: $100 = k10^3$, so $k = 100/10^3 = 0.1$. Thus,

$$\text{Cost of fuel per hour (in \$/hour)} = 0.1v^3.$$

From the given information, we also have

$$\text{Cost of other operations (labor, maintenance, etc.) per hour (in \$/hour)} = 675.$$

So

$$\begin{aligned} \text{Total Cost per hour (in \$/hour)} &= \text{Cost of fuel (in \$/hour)} + \text{Cost of other (in \$/hour)} \\ &= 0.1v^3 + 675. \end{aligned}$$

However, we want to find the Cost per *mile*, which is the Total Cost per *hour* divided by the number of miles that the ferry travels in one hour. Since v is the speed in miles/hour at which the ferry travels, the number of miles that the ferry travels in one hour is simply v miles. Let $C = \text{Cost per mile}$. Then

$$\begin{aligned} \text{Cost per mile (in \$/mile)} &= \frac{\text{Total Cost per hour (in \$/hour)}}{\text{Distance traveled per hour (in miles/hour)}} \\ C &= \frac{0.1v^3 + 675}{v} = 0.1v^2 + \frac{675}{v}. \end{aligned}$$

We also know that $0 < v < \infty$. To find the speed at which Cost per *mile* is minimized, set

$$\frac{dC}{dv} = 2(0.1)v - \frac{675}{v^2} = 0$$

so

$$\begin{aligned} 2(0.1)v &= \frac{675}{v^2} \\ v^3 &= \frac{675}{2(0.1)} = 3375 \\ v &= 15 \text{ miles/hour.} \end{aligned}$$

Since

$$\frac{d^2C}{dv^2} = 0.2 + \frac{2(675)}{v^3} > 0$$

for $v > 0$, $v = 15$ gives a local minimum for C by the second-derivative test. Since this is the only critical point for $0 < v < \infty$, it must give a global minimum.

18. (a) We have

$$x^{1/x} = e^{\ln(x^{1/x})} = e^{(1/x)\ln x}.$$

Thus

$$\begin{aligned} \frac{d(x^{1/x})}{dx} &= \frac{d(e^{(1/x)\ln x})}{dx} = \frac{d(\frac{1}{x}\ln x)}{dx} e^{(1/x)\ln x} \\ &= \left(-\frac{\ln x}{x^2} + \frac{1}{x^2}\right) x^{1/x} \\ &= \frac{x^{1/x}}{x^2} (1 - \ln x) \begin{cases} = 0 & \text{when } x = e \\ < 0 & \text{when } x > e \\ > 0 & \text{when } x < e. \end{cases} \end{aligned}$$

Hence $e^{1/e}$ is the global maximum for $x^{1/x}$, by the first derivative test.

- (b) Since $x^{1/x}$ is increasing for $0 < x < e$ and decreasing for $x > e$, and 2 and 3 are the closest integers to e , either $2^{1/2}$ or $3^{1/3}$ is the maximum for $n^{1/n}$. We have $2^{1/2} \approx 1.414$ and $3^{1/3} \approx 1.442$, so $3^{1/3}$ is the maximum.
- (c) Since $e < 3 < \pi$, and $x^{1/x}$ is decreasing for $x > e$, $3^{1/3} > \pi^{1/\pi}$.
19. (a) If, following the hint, we set $f(x) = (a+x)/2 - \sqrt{ax}$, then $f(x)$ represents the difference between the arithmetic and geometric means for some fixed a and any $x > 0$. We can find where this difference is minimized by solving $f'(x) = 0$. Since $f'(x) = \frac{1}{2} - \frac{1}{2}\sqrt{ax}^{-1/2}$, if $f'(x) = 0$ then $\frac{1}{2}\sqrt{ax}^{-1/2} = \frac{1}{2}$, or $x = a$. Since $f''(x) = \frac{1}{4}\sqrt{ax}^{-3/2}$ is positive for all positive x , by the second derivative test $f(x)$ has a minimum at $x = a$, and $f(a) = 0$. Thus $f(x) = (a+x)/2 - \sqrt{ax} \geq 0$ for all $x > 0$, which means $(a+x)/2 \geq \sqrt{ax}$. This means that the arithmetic mean is greater than the geometric mean unless $a = x$, in which case the two means are equal.

Alternatively, and without using calculus, we obtain

$$\begin{aligned} \frac{a+b}{2} - \sqrt{ab} &= \frac{a - 2\sqrt{ab} + b}{2} \\ &= \frac{(\sqrt{a} - \sqrt{b})^2}{2} \geq 0. \end{aligned}$$

and again we have $(a+b)/2 \geq \sqrt{ab}$.

- (b) Following the hint, set $f(x) = \frac{a+b+x}{3} - \sqrt[3]{abx}$. Then $f(x)$ represents the difference between the arithmetic and geometric means for some fixed a, b and any $x > 0$. We can find where this difference is minimized by solving $f'(x) = 0$. Since $f'(x) = \frac{1}{3} - \frac{1}{3}\sqrt[3]{abx}^{-2/3}$, $f'(x) = 0$ implies that $\frac{1}{3}\sqrt[3]{abx}^{-2/3} = \frac{1}{3}$, or $x = \sqrt{ab}$. Since $f''(x) = \frac{2}{9}\sqrt[3]{abx}^{-5/3}$ is positive for all positive x , by the second derivative test $f(x)$ has a minimum at $x = \sqrt{ab}$. But

$$f(\sqrt{ab}) = \frac{a+b+\sqrt{ab}}{3} - \sqrt[3]{ab\sqrt{ab}} = \frac{a+b+\sqrt{ab}}{3} - \sqrt{ab} = \frac{a+b-2\sqrt{ab}}{3}.$$

By the first part of this problem, we know that $\frac{a+b}{2} - \sqrt{ab} \geq 0$, which implies that $a+b-2\sqrt{ab} \geq 0$. Thus $f(\sqrt{ab}) = \frac{a+b-2\sqrt{ab}}{3} \geq 0$. Since f has a maximum at $x = \sqrt{ab}$, $f(x)$ is always nonnegative. Thus $f(x) = \frac{a+b+x}{3} - \sqrt[3]{abx} \geq 0$, so $\frac{a+b+c}{3} \geq \sqrt[3]{abc}$. Note that equality holds only when $a = b = c$. (Part (b) may also be done without calculus, but it's harder than (a).)

20.

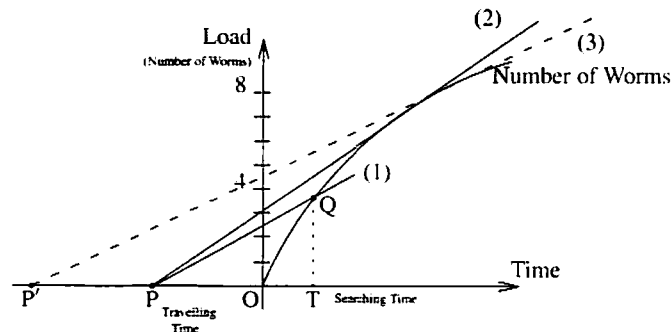

- (a) See line (1). For any point
- Q
- on the loading curve, the line
- PQ
- has slope

$$\frac{QT}{PT} = \frac{QT}{PO + OT} = \frac{\text{load}}{\text{traveling time} + \text{searching time}}.$$

- (b) The slope of the line PQ is maximized when the line is tangent to the loading curve, which happens with line (2). The load is then approximately 7 worms.
- (c) If the traveling time is increased, the point P moves to the left, to point P' , say. If line (3) is tangent to the curve, it will be tangent to the curve further to the right than line (2), so the optimal load is larger. This makes sense: if the bird has to fly further, you'd expect it to bring back more worms each time.
21. Let x be as indicated in the figure in the text. Then the distance from S to Town 1 is $\sqrt{1+x^2}$ and the distance from S to Town 2 is $\sqrt{(4-x)^2+4^2} = \sqrt{x^2-8x+32}$.

$$\text{Total length of pipe} = f(x) = \sqrt{1+x^2} + \sqrt{x^2-8x+32}.$$

We want to look for critical points of f . The easiest way is to graph f and see that it has a local minimum at about $x = 0.8$ miles. Alternatively, we can use the formula:

$$\begin{aligned} f'(x) &= \frac{2x}{2\sqrt{1+x^2}} + \frac{2x-8}{2\sqrt{x^2-8x+32}} \\ &= \frac{x}{\sqrt{1+x^2}} + \frac{x-4}{\sqrt{x^2-8x+32}} \\ &= \frac{x\sqrt{x^2-8x+32} + (x-4)\sqrt{1+x^2}}{\sqrt{1+x^2}\sqrt{x^2-8x+32}} = 0. \end{aligned}$$

$f'(x)$ is equal to zero when the numerator is equal to zero.

$$\begin{aligned} x\sqrt{x^2-8x+32} + (x-4)\sqrt{1+x^2} &= 0 \\ x\sqrt{x^2-8x+32} &= (4-x)\sqrt{1+x^2}. \end{aligned}$$

Squaring both sides and simplifying, we get

$$\begin{aligned} x^2(x^2-8x+32) &= (x^2-8x+16)(14x^2) \\ x^4-8x^3+32x^2 &= x^4-8x^3+17x^2-8x+16 \\ 15x^2+8x-16 &= 0. \\ (3x+4)(5x-4) &= 0. \end{aligned}$$

So $x = 4/5$. (Discard $x = -4/3$ since we are only interested in x between 0 and 4, between the two towns.) Using the second derivative test, we can verify that $x = 4/5$ is a local minimum.

22. (a) The distance the pigeon flies over water is

$$\overline{BP} = \frac{\overline{AB}}{\sin \theta} = \frac{500}{\sin \theta},$$

and over land is

$$\overline{PL} = \overline{AL} - \overline{AP} = 2000 - \frac{500}{\tan \theta} = 2000 - \frac{500 \cos \theta}{\sin \theta}.$$

Therefore the energy required is

$$\begin{aligned} E &= 2e \left(\frac{500}{\sin \theta} \right) + e \left(2000 - \frac{500 \cos \theta}{\sin \theta} \right) \\ &= 500e \left(\frac{2 - \cos \theta}{\sin \theta} \right) + 2000e, \quad \text{for } \arctan \left(\frac{500}{2000} \right) \leq \theta \leq \frac{\pi}{2}. \end{aligned}$$

- (b) Notice that E and the function $f(\theta) = \frac{2 - \cos \theta}{\sin \theta}$ must have the same critical points since the graph of E is just a stretch and a vertical shift of the graph of f . The graph of $\frac{2 - \cos \theta}{\sin \theta}$ for $\arctan(\frac{500}{2000}) \leq \theta \leq \frac{\pi}{2}$ in Figure 4.54 shows that E has precisely one critical point, and that a minimum for E occurs at this point.

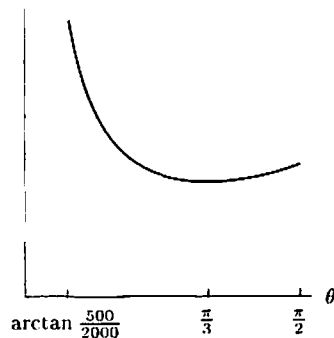

Figure 4.54: Graph of $f(\theta) = \frac{2 - \cos \theta}{\sin \theta}$ for $\arctan\left(\frac{500}{2000}\right) \leq \theta \leq \frac{\pi}{2}$

To find the critical point θ , we solve $f'(\theta) = 0$ or

$$\begin{aligned} E' = 0 &= 500e \left(\frac{\sin \theta \cdot \sin \theta - (2 - \cos \theta) \cdot \cos \theta}{\sin^2 \theta} \right) \\ &= 500e \left(\frac{1 - 2 \cos \theta}{\sin^2 \theta} \right). \end{aligned}$$

Therefore $1 - 2 \cos \theta = 0$ and so $\theta = \pi/3$.

(c) Letting $a = \overline{AB}$ and $b = \overline{AL}$, our formula for E becomes

$$\begin{aligned} E &= 2e \left(\frac{a}{\sin \theta} \right) + e \left(b - \frac{a \cos \theta}{\sin \theta} \right) \\ &= ea \left(\frac{2 - \cos \theta}{\sin \theta} \right) + eb, \quad \text{for } \arctan\left(\frac{a}{b}\right) \leq \theta \leq \frac{\pi}{2}. \end{aligned}$$

Again, the graph of E is just a stretch and a vertical shift of the graph of $\frac{2 - \cos \theta}{\sin \theta}$. Thus, the critical point $\theta = \pi/3$ is independent of e , a , and b . But the maximum of E on the domain $\arctan(a/b) \leq \theta \leq \frac{\pi}{2}$ is dependent on the ratio $a/b = \frac{\overline{AB}}{\overline{AL}}$. In other words, the optimal angle is $\theta = \pi/3$ provided $\arctan(a/b) \leq \frac{\pi}{3}$; otherwise, the optimal angle is $\arctan(a/b)$, which means the pigeon should fly over the lake for the entire trip—this occurs when $a/b > 1.733$.

23. We want to maximize the viewing angle, which is $\theta = \theta_1 - \theta_2$.

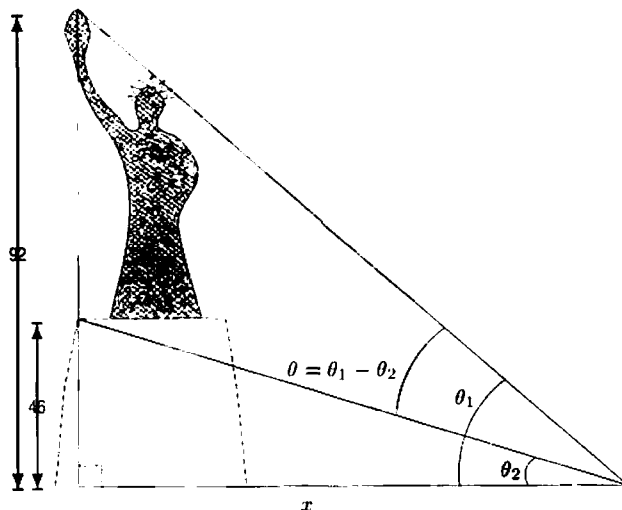

Now

$$\begin{aligned}\tan(\theta_1) &= \frac{92}{x} & \text{so } \theta_1 &= \arctan\left(\frac{92}{x}\right) \\ \tan(\theta_2) &= \frac{46}{x} & \text{so } \theta_2 &= \arctan\left(\frac{46}{x}\right).\end{aligned}$$

Then

$$\theta = \arctan\left(\frac{92}{x}\right) - \arctan\left(\frac{46}{x}\right) \quad \text{for } x > 0.$$

We look for critical points of the function by computing $d\theta/dx$:

$$\begin{aligned}\frac{d\theta}{dx} &= \frac{1}{1 + (92/x)^2} \left(\frac{-92}{x^2}\right) - \frac{1}{1 + (46/x)^2} \left(\frac{-46}{x^2}\right) \\ &= \frac{-92}{x^2 + 92^2} - \frac{-46}{x^2 + 46^2} \\ &= \frac{-92(x^2 + 46^2) + 46(x^2 + 92^2)}{(x^2 + 92^2) \cdot (x^2 + 46^2)} \\ &= \frac{46(4232 - x^2)}{(x^2 + 92^2) \cdot (x^2 + 46^2)}.\end{aligned}$$

Setting $d\theta/dx = 0$ gives

$$\begin{aligned}x^2 &= 4232 \\ x &= \pm\sqrt{4232}.\end{aligned}$$

Since $x > 0$, the critical point is $x = \sqrt{4232} \approx 65.1$ meters. To verify that this is indeed where θ attains a maximum, we note that $d\theta/dx > 0$ for $0 < x < \sqrt{4232}$ and $d\theta/dx < 0$ for $x > \sqrt{4232}$. By the First Derivative Test, θ attains a maximum at $x = \sqrt{4232} \approx 65.1$.

24. (a) Since the speed of light is a constant, the time of travel is minimized when the distance of travel is minimized. From Figure 4.55,

$$\begin{aligned}\text{Distance } \overline{OP} &= \sqrt{x^2 + 1^2} = \sqrt{x^2 + 1} \\ \text{Distance } \overline{PQ} &= \sqrt{(2-x)^2 + 1^2} = \sqrt{(2-x)^2 + 1}\end{aligned}$$

Thus,

$$\text{Total distance traveled} = s = \sqrt{x^2 + 1} + \sqrt{(2-x)^2 + 1}.$$

The total distance is a minimum if

$$\frac{ds}{dx} = \frac{1}{2}(x^2 + 1)^{-1/2} \cdot 2x + \frac{1}{2}((2-x)^2 + 1)^{-1/2} \cdot 2(2-x)(-1) = 0,$$

giving

$$\begin{aligned}\frac{x}{\sqrt{x^2 + 1}} - \frac{2-x}{\sqrt{(2-x)^2 + 1}} &= 0 \\ \frac{x}{\sqrt{x^2 + 1}} &= \frac{2-x}{\sqrt{(2-x)^2 + 1}}\end{aligned}$$

Squaring both sides gives

$$\frac{x^2}{x^2 + 1} = \frac{(2-x)^2}{(2-x)^2 + 1}.$$

Cross multiplying gives

$$x^2((2-x)^2 + 1) = (2-x)^2(x^2 + 1).$$

Multiplying out

$$\begin{aligned}x^2(4 - 4x + x^2 + 1) &= (4 - 4x + x^2)(x^2 + 1) \\ 4x^2 - 4x^3 + x^4 + x^2 &= 4x^2 - 4x^3 + x^4 + 4 - 4x + x^2.\end{aligned}$$

Collecting terms and canceling gives

$$0 = 4 - 4x$$

$$x = 1.$$

We can see that this value of x gives a minimum by comparing the value of s at this point and at the endpoints, $x = 0, x = 2$.

At $x = 1$,

$$s = \sqrt{1^2 + 1} + \sqrt{(2-1)^2 + 1} = 2.83.$$

At $x = 0$,

$$s = \sqrt{0^2 + 1} + \sqrt{(2-0)^2 + 1} = 3.24.$$

At $x = 2$,

$$s = \sqrt{2^2 + 1} + \sqrt{(2-2)^2 + 1} = 3.24.$$

Thus the shortest travel time occurs when $x = 1$; that is, when P is at the point $(1, 1)$.

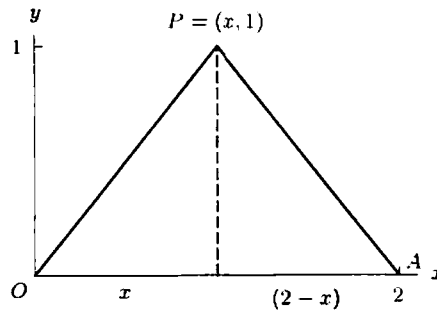

Figure 4.55

(b) Since $x = 1$ is halfway between $x = 0$ and $x = 2$, the angles θ_1 and θ_2 are equal.

25. (a) Since $RB' = x$ and $A'R = c - x$, we have

$$AR = \sqrt{a^2 + (c-x)^2} \quad \text{and} \quad RB = \sqrt{b^2 + x^2}.$$

See Figure 4.56.

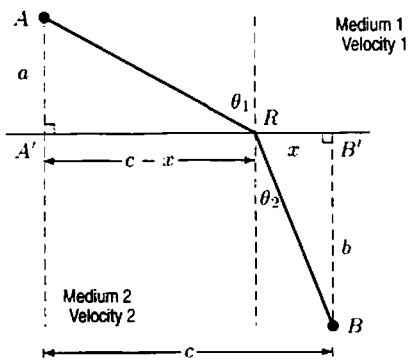

Figure 4.56

The time traveled, T , is given by

$$\begin{aligned} T &= \text{Time } AR + \text{Time } RB = \frac{\text{Distance } AR}{v_1} + \frac{\text{Distance } RB}{v_2} \\ &= \frac{\sqrt{a^2 + (c-x)^2}}{v_1} + \frac{\sqrt{b^2 + x^2}}{v_2}. \end{aligned}$$

(b) Let us calculate dT/dx :

$$\frac{dT}{dx} = \frac{-2(c-x)}{2v_1\sqrt{a^2+(c-x)^2}} + \frac{2x}{2v_2\sqrt{b^2+x^2}}.$$

At the minimum $dT/dx = 0$, so

$$\frac{c-x}{v_1\sqrt{a^2+(c-x)^2}} = \frac{x}{v_2\sqrt{b^2+x^2}}.$$

But we have

$$\sin \theta_1 = \frac{c-x}{\sqrt{a^2+(c-x)^2}} \quad \text{and} \quad \sin \theta_2 = \frac{x}{\sqrt{b^2+x^2}}.$$

Therefore, setting $dT/dx = 0$ tells us that

$$\frac{\sin \theta_1}{v_1} = \frac{\sin \theta_2}{v_2}$$

which gives

$$\frac{\sin \theta_1}{\sin \theta_2} = \frac{v_1}{v_2}.$$

26. We know that the time taken is given by

$$T = \frac{\sqrt{a^2+(c-x)^2}}{v_1} + \frac{\sqrt{b^2+x^2}}{v_2}$$

$$\frac{dT}{dx} = \frac{-(c-x)}{v_1\sqrt{a^2+(c-x)^2}} + \frac{x}{v_2\sqrt{b^2+x^2}}.$$

Differentiating again gives

$$\begin{aligned} \frac{d^2T}{dx^2} &= \frac{1}{v_1\sqrt{a^2+(c-x)^2}} + \frac{(c-x)(-2(c-x))}{2v_1(a^2+(c-x)^2)^{3/2}} + \frac{1}{v_2\sqrt{b^2+x^2}} - \frac{x(2x)}{2v_2(b^2+x^2)^{3/2}} \\ &= \frac{a^2+(c-x)^2-(c-x)^2}{v_1(a^2+(c-x)^2)^{3/2}} + \frac{b^2+x^2-x^2}{v_2(b^2+x^2)^{3/2}} \\ &= \frac{a^2}{v_1(a^2+(c-x)^2)^{3/2}} + \frac{b^2}{v_2(b^2+x^2)^{3/2}}. \end{aligned}$$

This expression for d^2T/dx^2 shows that for any value of x , a , c , v_1 , and v_2 with $v_1, v_2 > 0$, we have $d^2T/dx^2 > 0$. Thus, any critical point must be a local minimum. Since there is only one critical point, it must be a global minimum.

Solutions for Section 4.6

Exercises

1. Using the chain rule, $\frac{d}{dx}(\cosh(2x)) = (\sinh(2x)) \cdot 2 = 2 \sinh(2x)$.

2. Using the chain rule, $\frac{d}{dz}(\sinh(3z+5)) = \cosh(3z+5) \cdot 3 = 3 \cosh(3z+5)$.

3. Using the chain rule,

$$\frac{d}{dt}(\cosh(\sinh t)) = \sinh(\sinh t) \cdot \cosh t$$

4. Using the product rule,

$$\frac{d}{dt}(t^3 \sinh t) = 3t^2 \sinh t + t^3 \cosh t.$$

5. Using the chain rule,

$$\frac{d}{dt}(\cosh^2 t) = 2 \cosh t \cdot \sinh t.$$

6. Using the chain rule twice, $\frac{d}{dt}(\cosh(e^{t^2})) = \sinh(e^{t^2}) \cdot e^{t^2} \cdot 2t = 2te^{t^2} \sinh(e^{t^2})$.

7. Using the chain rule twice,

$$\begin{aligned}\frac{d}{dy}(\sinh(\sinh(3y))) &= \cosh(\sinh(3y)) \cdot \cosh(3y) \cdot 3 \\ &= 3 \cosh(3y) \cdot \cosh(\sinh(3y)).\end{aligned}$$

8. Using the chain rule,

$$\frac{d}{d\theta}(\ln(\cosh(1+\theta))) = \frac{1}{\cosh(1+\theta)} \cdot \sinh(1+\theta) = \frac{\sinh(1+\theta)}{\cosh(1+\theta)} = \tanh(1+\theta).$$

9. Substitute $x = 0$ into the formula for $\sinh x$. This yields

$$\sinh 0 = \frac{e^0 - e^{-0}}{2} = \frac{1 - 1}{2} = 0.$$

10. Substituting $-x$ for x in the formula for $\sinh x$ gives

$$\sinh(-x) = \frac{e^{-x} - e^{-(-x)}}{2} = \frac{e^{-x} - e^x}{2} = -\frac{e^x - e^{-x}}{2} = -\sinh x.$$

11. Using the formula for $\sinh x$ and the fact that $d(e^{-x})/dx = -e^{-x}$, we see that

$$\frac{d}{dx}\left(\frac{e^x - e^{-x}}{2}\right) = \frac{e^x + e^{-x}}{2} = \cosh x.$$

Problems

12. The graph of $\sinh x$ in the text suggests that

$$\text{As } x \rightarrow \infty, \quad \sinh x \rightarrow \frac{1}{2}e^x.$$

$$\text{As } x \rightarrow -\infty, \quad \sinh x \rightarrow -\frac{1}{2}e^{-x}.$$

Using the facts that

$$\text{As } x \rightarrow \infty, \quad e^{-x} \rightarrow 0,$$

$$\text{As } x \rightarrow -\infty, \quad e^x \rightarrow 0,$$

we can obtain the same results analytically:

$$\text{As } x \rightarrow \infty, \quad \sinh x = \frac{e^x - e^{-x}}{2} \rightarrow \frac{1}{2}e^x.$$

$$\text{As } x \rightarrow -\infty, \quad \sinh x = \frac{e^x - e^{-x}}{2} \rightarrow -\frac{1}{2}e^{-x}.$$

13. First we observe that

$$\sinh(2x) = \frac{e^{2x} - e^{-2x}}{2}.$$

Now let's calculate

$$\begin{aligned}(\sinh x)(\cosh x) &= \left(\frac{e^x - e^{-x}}{2}\right) \left(\frac{e^x + e^{-x}}{2}\right) \\ &= \frac{(e^x)^2 - (e^{-x})^2}{4} \\ &= \frac{e^{2x} - e^{-2x}}{4} \\ &= \frac{1}{2} \sinh(2x).\end{aligned}$$

Thus, we see that

$$\sinh(2x) = 2 \sinh x \cosh x.$$

14. First, we observe that

$$\cosh(2x) = \frac{e^{2x} + e^{-2x}}{2}.$$

Now let's use the fact that $e^x \cdot e^{-x} = 1$ to calculate

$$\begin{aligned} \cosh^2 x &= \left(\frac{e^x + e^{-x}}{2} \right)^2 \\ &= \frac{(e^x)^2 + 2e^x \cdot e^{-x} + (e^{-x})^2}{4} \\ &= \frac{e^{2x} + 2 + e^{-2x}}{4}. \end{aligned}$$

Similarly, we have

$$\begin{aligned} \sinh^2 x &= \left(\frac{e^x - e^{-x}}{2} \right)^2 \\ &= \frac{(e^x)^2 - 2e^x \cdot e^{-x} + (e^{-x})^2}{4} \\ &= \frac{e^{2x} - 2 + e^{-2x}}{4}. \end{aligned}$$

Thus, to obtain $\cosh(2x)$, we need to add (rather than subtract) $\cosh^2 x$ and $\sinh^2 x$, giving

$$\begin{aligned} \cosh^2 x + \sinh^2 x &= \frac{e^{2x} + 2 + e^{-2x} + e^{2x} - 2 + e^{-2x}}{4} \\ &= \frac{2e^{2x} + 2e^{-2x}}{4} \\ &= \frac{e^{2x} + e^{-2x}}{2} \\ &= \cosh(2x). \end{aligned}$$

Thus, we see that the identity relating $\cosh(2x)$ to $\cosh x$ and $\sinh x$ is

$$\cosh(2x) = \cosh^2 x + \sinh^2 x.$$

15. (a) Substituting $x = 0$ gives

$$\tanh 0 = \frac{e^0 - e^{-0}}{e^0 + e^{-0}} = \frac{1 - 1}{2} = 0.$$

(b) Since $\tanh x = \frac{e^x - e^{-x}}{e^x + e^{-x}}$ and $e^x + e^{-x}$ is always positive, $\tanh x$ has the same sign as $e^x - e^{-x}$. For $x > 0$, we have $e^x > 1$ and $e^{-x} < 1$, so $e^x - e^{-x} > 0$. For $x < 0$, we have $e^x < 1$ and $e^{-x} > 1$, so $e^x - e^{-x} < 0$. For $x = 0$, we have $e^x = 1$ and $e^{-x} = 1$, so $e^x - e^{-x} = 0$. Thus, $\tanh x$ is positive for $x > 0$, negative for $x < 0$, and zero for $x = 0$.

(c) Taking the derivative, we have

$$\frac{d}{dx}(\tanh x) = \frac{1}{\cosh^2 x}.$$

Thus, for all x ,

$$\frac{d}{dx}(\tanh x) > 0.$$

Thus, $\tanh x$ is increasing everywhere.

(d) As $x \rightarrow \infty$ we have $e^{-x} \rightarrow 0$; as $x \rightarrow -\infty$, we have $e^x \rightarrow 0$. Thus

$$\begin{aligned} \lim_{x \rightarrow \infty} \tanh x &= \lim_{x \rightarrow \infty} \left(\frac{e^x - e^{-x}}{e^x + e^{-x}} \right) = 1, \\ \lim_{x \rightarrow -\infty} \tanh x &= \lim_{x \rightarrow -\infty} \left(\frac{e^x - e^{-x}}{e^x + e^{-x}} \right) = -1. \end{aligned}$$

Thus, $y = 1$ and $y = -1$ are horizontal asymptotes to the graph of $\tanh x$. See Figure 4.57.

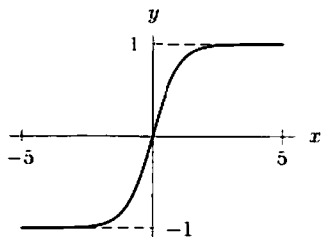
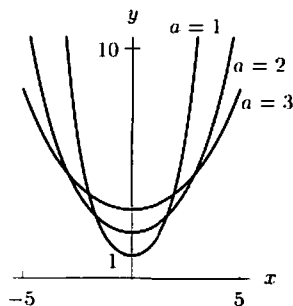

Figure 4.57: Graph of $y = \tanh x$

(e) The graph of $\tanh x$ suggests that $\tanh x$ is increasing everywhere; the fact that the derivative of $\tanh x$ is positive for all x confirms this. Since $\tanh x$ is increasing for all x , different values of x lead to different values of y , and therefore $\tanh x$ does have an inverse.

16. For $-5 \leq x \leq 5$, we have the graphs of $y = a \cosh(x/a)$ shown below.



Increasing the value of a makes the graph flatten out and raises the minimum value. The minimum value of y occurs at $x = 0$ and is given by

$$y = a \cosh\left(\frac{0}{a}\right) = a \left(\frac{e^{0/a} + e^{-0/a}}{2} \right) = a.$$

17. (a) The graph in Figure 4.58 looks like the graph of $y = \cosh x$, with the minimum at about $(0.5, 6.3)$.

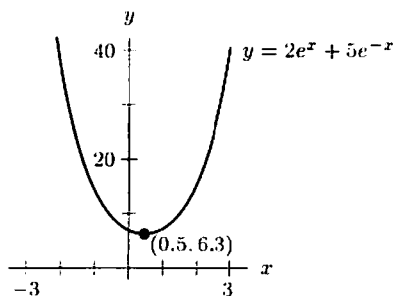

Figure 4.58

(b) We want to write

$$\begin{aligned} y = 2e^x + 5e^{-x} &= A \cosh(x - c) = \frac{A}{2} e^{x-c} + \frac{A}{2} e^{-(x-c)} \\ &= \frac{A}{2} e^x e^{-c} + \frac{A}{2} e^{-x} e^c \\ &= \left(\frac{Ae^{-c}}{2} \right) e^x + \left(\frac{Ae^c}{2} \right) e^{-x}. \end{aligned}$$

Thus, we need to choose A and c so that

$$\frac{Ae^{-c}}{2} = 2 \quad \text{and} \quad \frac{Ae^c}{2} = 5.$$

Dividing gives

$$\begin{aligned} \frac{Ae^c}{Ae^{-c}} &= \frac{5}{2} \\ e^{2c} &= 2.5 \\ c &= \frac{1}{2} \ln 2.5 \approx 0.458. \end{aligned}$$

Solving for A gives

$$A = \frac{4}{e^{-c}} = 4e^c \approx 6.325.$$

Thus,

$$y = 6.325 \cosh(x - 0.458).$$

Rewriting the function in this way shows that the graph in part (a) is the graph of $\cosh x$ shifted to the right by 0.458 and stretched vertically by a factor of 6.325.

18. We want to show that for any A, B with $A > 0, B > 0$, we can find K and c such that

$$\begin{aligned} y = Ae^x + Be^{-x} &= \frac{Ke^{(x-c)} + Ke^{-(x-c)}}{2} \\ &= \frac{K}{2}e^xe^{-c} + \frac{K}{2}e^{-x}e^c \\ &= \left(\frac{Ke^{-c}}{2}\right)e^x + \left(\frac{Ke^c}{2}\right)e^{-x}. \end{aligned}$$

Thus, we want to find K and c such that

$$\frac{Ke^{-c}}{2} = A \quad \text{and} \quad \frac{Ke^c}{2} = B.$$

Dividing, we have

$$\begin{aligned} \frac{Ke^c}{Ke^{-c}} &= \frac{B}{A} \\ e^{2c} &= \frac{B}{A} \\ c &= \frac{1}{2} \ln \left(\frac{B}{A}\right). \end{aligned}$$

If $A > 0, B > 0$, then there is a solution for c . Substituting to find K , we have

$$\begin{aligned} \frac{Ke^{-c}}{2} &= A \\ K &= 2Ae^c = 2Ae^{(\ln(B/A))/2} \\ &= 2Ae^{\ln \sqrt{B/A}} = 2A\sqrt{\frac{B}{A}} = 2\sqrt{AB}. \end{aligned}$$

Thus, if $A > 0, B > 0$, there is a solution for K also.

The fact that $y = Ae^x + Be^{-x}$ can be rewritten in this way shows that the graph of $y = Ae^x + Be^{-x}$ is the graph of $\cosh x$, shifted over by c and stretched (or shrunk) vertically by a factor of K .

19. (a) The graphs are shown in Figures 4.59–4.64.

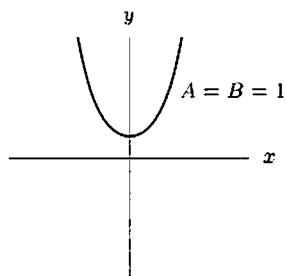
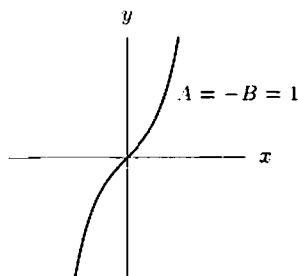
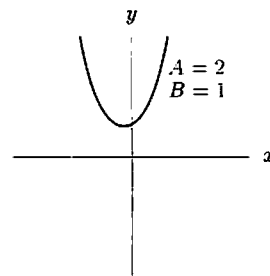
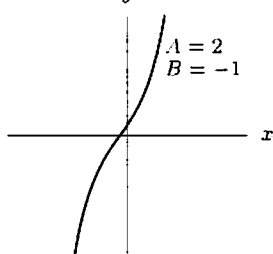
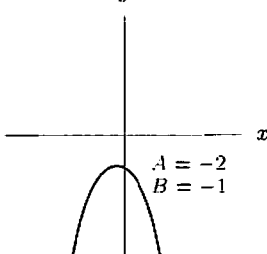
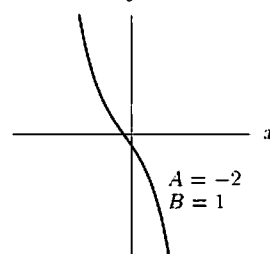
Figure 4.59: $A > 0, B > 0$ Figure 4.60: $A > 0, B < 0$ Figure 4.61: $A > 0, B > 0$ Figure 4.62: $A > 0, B < 0$ Figure 4.63: $A < 0, B < 0$ Figure 4.64: $A < 0, B > 0$

- (b) If A and B have the same sign, the graph is U -shaped. If A and B are both positive, the graph opens upward. If A and B are both negative, the graph opens downward.
- (c) If A and B have different signs, the graph appears to be everywhere increasing (if $A > 0, B < 0$) or decreasing (if $A < 0, B > 0$).
- (d) The function appears to have a local maximum if $A < 0$ and $B < 0$, and a local minimum if $A > 0$ and $B > 0$.
To justify this, calculate the derivative

$$\frac{dy}{dx} = Ae^x - Be^{-x}.$$

Setting $dy/dx = 0$ gives

$$\begin{aligned} Ae^x - Be^{-x} &= 0 \\ Ae^x &= Be^{-x} \\ e^{2x} &= \frac{B}{A}. \end{aligned}$$

This equation has a solution only if B/A is positive, that is, if A and B have the same sign. In that case,

$$\begin{aligned} 2x &= \ln\left(\frac{B}{A}\right) \\ x &= \frac{1}{2} \ln\left(\frac{B}{A}\right). \end{aligned}$$

This value of x gives the only critical point.

To determine whether the critical point is a local maximum or minimum, we use the first derivative test. Since

$$\frac{dy}{dx} = Ae^x - Be^{-x},$$

we see that:

If $A > 0, B > 0$, we have $dy/dx > 0$ for large positive x and $dy/dx < 0$ for large negative x , so there is a local minimum.

If $A < 0, B < 0$, we have $dy/dx < 0$ for large positive x and $dy/dx > 0$ for large negative x , so there is a local maximum.

20. (a) Since the cosh function is even, the height, y , is the same at $x = -T/w$ and $x = T/w$. The height at these endpoints is

$$y = \frac{T}{w} \cosh\left(\frac{w}{T} \cdot \frac{T}{w}\right) = \frac{T}{w} \cosh 1 = \frac{T}{w} \left(\frac{e^1 + e^{-1}}{2}\right).$$

At the lowest point, $x = 0$, and the height is

$$y = \frac{T}{w} \cosh 0 = \frac{T}{w}.$$

Thus the "sag" in the cable is given by

$$\text{Sag} = \frac{T}{w} \left(\frac{e + e^{-1}}{2}\right) - \frac{T}{w} = \frac{T}{w} \left(\frac{e + e^{-1}}{2} - 1\right) \approx 0.54 \frac{T}{w}.$$

- (b) To show that the differential equation is satisfied, take derivatives

$$\begin{aligned} \frac{dy}{dx} &= \frac{T}{w} \cdot \frac{w}{T} \sinh\left(\frac{wx}{T}\right) = \sinh\left(\frac{wx}{T}\right) \\ \frac{d^2y}{dx^2} &= \frac{w}{T} \cosh\left(\frac{wx}{T}\right). \end{aligned}$$

Therefore, using the fact that $1 + \sinh^2 a = \cosh^2 a$ and that cosh is always positive, we have:

$$\begin{aligned} \frac{w}{T} \sqrt{1 + \left(\frac{dy}{dx}\right)^2} &= \frac{w}{T} \sqrt{1 + \sinh^2\left(\frac{wx}{T}\right)} = \frac{w}{T} \sqrt{\cosh^2\left(\frac{wx}{T}\right)} \\ &= \frac{w}{T} \cosh\left(\frac{wx}{T}\right). \end{aligned}$$

So

$$\frac{w}{T} \sqrt{1 + \left(\frac{dy}{dx}\right)^2} = \frac{d^2y}{dx^2}.$$

21.

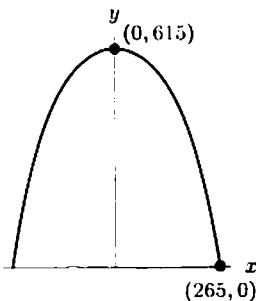

We know $x = 0$ and $y = 615$ at the top of the arch, so

$$615 = b - a \cosh(0/a) = b - a.$$

This means $b = a + 615$. We also know that $x = 265$ and $y = 0$ where the arch hits the ground, so

$$0 = b - a \cosh(265/a) = a + 615 - a \cosh(265/a).$$

We can solve this equation numerically on a calculator and get $a \approx 100$, which means $b \approx 715$. This results in the equation

$$y \approx 715 - 100 \cosh\left(\frac{x}{100}\right).$$

Solutions for Section 4.7

Exercises

- False. For example, if $f(x) = x^3$, then $f'(0) = 0$, so $x = 0$ is a critical point, but $x = 0$ is neither a local maximum nor a local minimum.
- False. The derivative, $f'(x)$, is not equal to zero everywhere, because the function is not continuous at integral values of x , so $f'(x)$ does not exist there. Thus, the Constant Function Theorem does not apply.
- False, since $f(x) = 1/x$ takes on arbitrarily large values as $x \rightarrow 0^+$. The Extreme Value Theorem requires the interval to be closed as well as bounded.
- False. The Extreme Value Theorem says that continuous functions have global maxima and minima on every closed, bounded interval. It does not say that only continuous functions have such maxima and minima.
- False. The horse that wins the race may have been moving faster for some, but not all, of the race. The Racetrack Principle guarantees the converse—that if the horses start at the same time and one moves faster throughout the race, then that horse wins.
- True. If $g(x)$ is the position of the slower horse at time x and $h(x)$ is the position of the faster, then $g'(x) \leq h'(x)$ for $a < x < b$. Since the horses start at the same time, $g(a) = h(a)$, so, by the Racetrack Principle, $g(x) \leq h(x)$ for $a \leq x \leq b$. Therefore, $g(b) \leq h(b)$, so the slower horse loses the race.
- True. If f' is positive on $[a, b]$, then f is continuous and the Increasing Function Theorem applies. Thus, f is increasing on $[a, b]$, so $f(a) < f(b)$.
- False. Let $f(x) = x^3$ on $[-1, 1]$. Then $f(x)$ is increasing but $f'(x) = 0$ for $x = 0$.
- No, it does not satisfy the hypotheses. The function does not appear to be differentiable. There appears to be no tangent line, and hence no derivative, at the “corner.”
No, it does not satisfy the conclusion as there is no horizontal tangent.
- Yes, it satisfies the hypotheses and the conclusion. This function has two points, c , at which the tangent to the curve is parallel to the secant joining $(a, f(a))$ to $(b, f(b))$, but this does not contradict the Mean Value Theorem. The function is continuous and differentiable on the interval $[a, b]$.
- No, it does not satisfy the hypotheses. This function does not appear to be continuous.
No, it does not satisfy the conclusion as there is no horizontal tangent.
- No. This function does not satisfy the hypotheses of the Mean Value Theorem, as it is not continuous.
However, the function has a point c such that

$$f'(c) = \frac{f(b) - f(a)}{b - a}.$$

Thus, this satisfies the conclusion of the theorem.

Problems

- Let $f(x) = \sin x$ and $g(x) = x$. Then $f(0) = 0$ and $g(0) = 0$. Also $f'(x) = \cos x$ and $g'(x) = 1$, so for all $x \geq 0$ we have $f'(x) \leq g'(x)$. So the graphs of f and g both go through the origin and the graph of f climbs slower than the graph of g . Thus the graph of f is below the graph of g for $x \geq 0$ by the Racetrack Principle. In other words, $\sin x \leq x$ for $x \geq 0$.
- Let $g(x) = \ln x$ and $h(x) = x - 1$. For $x \geq 1$, we have $g'(x) = 1/x \leq 1 = h'(x)$. Since $g(1) = h(1)$, the Racetrack Principle with $a = 1$ says that $g(x) \leq h(x)$ for $x \geq 1$, that is, $\ln x \leq x - 1$ for $x \geq 1$. For $0 < x \leq 1$, we have $h'(x) = 1 \leq 1/x = g'(x)$. Since $g(1) = h(1)$, the Racetrack Principle with $b = 1$ says that $g(x) \leq h(x)$ for $0 < x \leq 1$, that is, $\ln x \leq x - 1$ for $0 < x \leq 1$.

15.

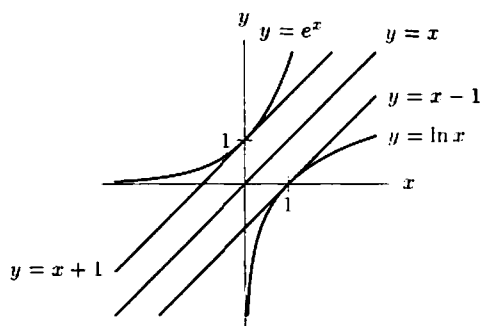

Graphical solution: If f and g are inverse functions then the graph of g is just the graph of f reflected through the line $y = x$. But e^x and $\ln x$ are inverse functions, and so are the functions $x + 1$ and $x - 1$. Thus the equivalence is clear from the figure.

Algebraic solution: If $x > 0$ and

$$x + 1 \leq e^x.$$

then, replacing x by $x - 1$, we have

$$x \leq e^{x-1}.$$

Taking logarithms, and using the fact that \ln is an increasing function, gives

$$\ln x \leq x - 1.$$

We can also go in the opposite direction, which establishes the equivalence.

16. If f is continuous then $-f$ is continuous also. So $-f$ has a global maximum at some point $x = c$. Thus $-f(x) \leq -f(c)$ for all x in $[a, b]$. Hence $f(x) \geq f(c)$ for all x in $[a, b]$. So f has a global minimum at $x = c$.
17. The Decreasing Function Theorem is: Suppose that f is continuous on $[a, b]$ and differentiable on (a, b) . If $f'(x) < 0$ on (a, b) , then f is decreasing on $[a, b]$. If $f'(x) \leq 0$ on (a, b) , then f is nonincreasing on $[a, b]$.
- To prove the theorem, we note that if f is decreasing then $-f$ is increasing and vice-versa. Similarly, if f is nonincreasing, then $-f$ is nondecreasing. Thus if $f'(x) < 0$, then $-f'(x) > 0$, so $-f$ is increasing, which means f is decreasing. And if $f'(x) \leq 0$, then $-f'(x) \geq 0$, so $-f$ is nondecreasing, which means f is nonincreasing.
18. Use the Racetrack Principle, Theorem 4.6, with $g(x) = x$. Since $f'(x) \leq g'(x)$ for all x and $f(0) = g(0)$, then $f(x) \leq g(x) = x$ for all $x \geq 0$.
19. First apply the Racetrack Principle, Theorem 4.6, to $f'(t)$ and $g(t) = 3t$. Since $f''(t) \leq g'(t)$ for all t and $f'(0) = 0 = g(0)$, then $f'(t) \leq 3t$ for all $t \geq 0$. Next apply the Racetrack Principle again to $f(t)$ and $h(t) = \frac{3}{2}t^2$. Since $f'(t) \leq h'(t)$ for all $t \geq 0$ and $f(0) = 0 = h(0)$, then $f(t) \leq h(t) = \frac{3}{2}t^2$ for all $t \geq 0$.
20. Apply the Constant Function Theorem, Theorem 4.5, to $h(x) = f(x) - g(x)$. Then $h'(x) = 0$ for all x , so $h(x)$ is constant for all x . Since $h(5) = f(5) - g(5) = 0$, we have $h(x) = 0$ for all x . Therefore $f(x) - g(x) = 0$ for all x , so $f(x) = g(x)$ for all x .
21. By the Mean Value Theorem, Theorem 4.3, there is a number c , with $0 < c < 1$, such that

$$f'(c) = \frac{f(1) - f(0)}{1 - 0}.$$

Since $f(1) - f(0) > 0$, we have $f'(c) > 0$.

Alternatively if $f'(c) \leq 0$ for all c in $(0, 1)$, then by the Increasing Function Theorem, $f(0) \geq f(1)$.

22. Suppose f has critical points $x = a$ and $x = b$. Suppose $a < b$. By the Extreme Value Theorem, we know that the derivative function, $f'(x)$, has global extrema on $[a, b]$. If both the maximum and minimum of $f'(x)$ occur at the endpoints of $[a, b]$, then $f'(a) = 0 = f'(b)$, so $f'(x) = 0$ for all x in $[a, b]$. In this case, f would have more than two critical points. Since f has only two critical points, there is a local maximum or minimum inside the interval $[a, b]$. Any local maximum or minimum of f' is an inflection point of f .
23. Since $f''(t) \leq 7$ for $0 \leq t \leq 2$, if we apply the Racetrack Principle with $a = 0$ to the functions $f'(t) - f'(0)$ and $7t$, both of which go through the origin, we get

$$f'(t) - f'(0) \leq 7t \quad \text{for } 0 \leq t \leq 2.$$

The left side of this inequality is the derivative of $f(t) - f'(0)t$, so if we apply the Racetrack Principle with $a = 0$ again, this time to the functions $f(t) - f'(0)t$ and $(7/2)t^2 + 3$, both of which have the value 3 at $t = 0$, we get

$$f(t) - f'(0)t \leq \frac{7}{2}t^2 + 3 \quad \text{for } 0 \leq t \leq 2.$$

That is,

$$f(t) \leq 3 + 4t - \frac{7}{2}t^2 \quad \text{for } 0 \leq t \leq 2.$$

In the same way, we can show that the lower bound on the acceleration, $5 \leq f''(t)$ leads to:

$$f(t) \geq 3 + 4t + \frac{5}{2}t^2 \quad \text{for } 0 \leq t \leq 2.$$

If we substitute $t = 2$ into these two inequalities, we get bounds on the position at time 2:

$$21 \leq f(2) \leq 25.$$

24. Consider the function $f(x) = h(x) - g(x)$. Since $f'(x) = h'(x) - g'(x) \geq 0$, we know that f is nondecreasing by the Increasing Function Theorem. This means $f(x) \leq f(b)$ for $a \leq x \leq b$. However, $f(b) = h(b) - g(b) = 0$, so $f(x) \leq 0$, which means $h(x) \leq g(x)$.
25. If $f'(x) = 0$, then both $f'(x) \geq 0$ and $f'(x) \leq 0$. By the Increasing and Decreasing Function Theorems, f is both nondecreasing and nonincreasing, so f is constant.
26. Let $h(x) = f(x) - g(x)$. Then $h'(x) = f'(x) - g'(x) = 0$ for all x in (a, b) . Hence, by the Constant Function Theorem, there is a constant C such that $h(x) = C$ on (a, b) . Thus $f(x) = g(x) + C$.
27. We will show $f(x) = Ce^x$ by deducing that $f(x)/e^x$ is a constant. By the Constant Function Theorem, we need only show the derivative of $g(x) = f(x)/e^x$ is zero. By the quotient rule (since $e^x \neq 0$), we have

$$g'(x) = \frac{f'(x)e^x - e^x f(x)}{(e^x)^2}.$$

Since $f'(x) = f(x)$, we simplify and obtain

$$g'(x) = \frac{f(x)e^x - e^x f(x)}{(e^x)^2} = \frac{0}{e^{2x}} = 0.$$

which is what we needed to show.

28. Apply the Racetrack Principle to the functions $f(x) - f(a)$ and $M(x - a)$; we can do this since $f(a) - f(a) = M(a - a)$ and $f'(x) \leq M$. We conclude that $f(x) - f(a) \leq M(x - a)$. Similarly, apply the Racetrack Principle to the functions $m(x - a)$ and $f(x) - f(a)$ to obtain $m(x - a) \leq f(x) - f(a)$. If we substitute $x = b$ into these inequalities we get

$$m(b - a) \leq f(b) - f(a) \leq M(b - a).$$

Now, divide by $b - a$.

29. (a) Since $f''(x) \geq 0$, $f'(x)$ is nondecreasing on (a, b) . Thus $f'(c) \leq f'(x)$ for $c \leq x < b$ and $f'(x) \leq f'(c)$ for $a < x \leq c$.
 (b) Let $g(x) = f(c) + f'(c)(x - c)$ and $h(x) = f(x)$. Then $g(c) = f(c) = h(c)$, and $g'(x) = f'(c)$ and $h'(x) = f'(x)$. If $c \leq x < b$, then $g'(x) \leq h'(x)$, and if $a < x \leq c$, then $g'(x) \geq h'(x)$, by (a). By the Racetrack Principle, $g(x) \leq h(x)$ for $c \leq x < b$ and for $a < x \leq c$, as we wanted.
30. (a) If both the global minimum and the global maximum are at the endpoints, then $f(x) = 0$ everywhere in $[a, b]$, since $f(a) = f(b) = 0$. In that case $f'(x) = 0$ everywhere as well, so any point in (a, b) will do for c .
 (b) Suppose that either the global maximum or the global minimum occurs at an interior point of the interval. Let c be that point. Then c must be a local extremum of f , so, by the theorem concerning local extrema on page 168, we have $f'(c) = 0$, as required.
31. (a) The equation of the secant line between $x = a$ and $x = b$ is

$$y = f(a) + \frac{f(b) - f(a)}{b - a}(x - a)$$

and

$$g(x) = f(x) - f(a) - \frac{f(b) - f(a)}{b - a}(x - a),$$

so $g(x)$ is the difference, or distance, between the graph of $f(x)$ and the secant line. See Figure 4.65.

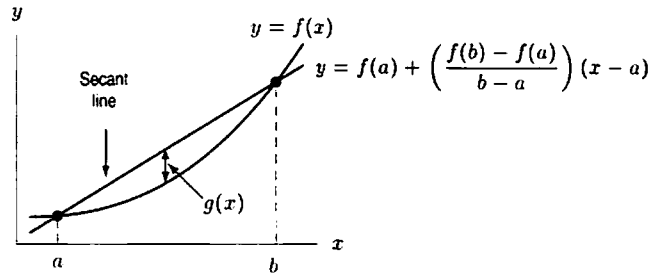

Figure 4.65: Value of $g(x)$ is the difference between the secant line and the graph of $f(x)$

- (b) Figure 4.65 shows that $g(a) = g(b) = 0$. You can also easily check this from the formula for $g(x)$. By Rolle's Theorem, there must be a point c in (a, b) where $g'(c) = 0$.
- (c) Differentiating the formula for $g(x)$, we have

$$g'(x) = f'(x) - \frac{f(b) - f(a)}{b - a}.$$

So from $g'(c) = 0$, we get

$$f'(c) = \frac{f(b) - f(a)}{b - a}.$$

as required.

Solutions for Chapter 4 Review

Exercises

1.

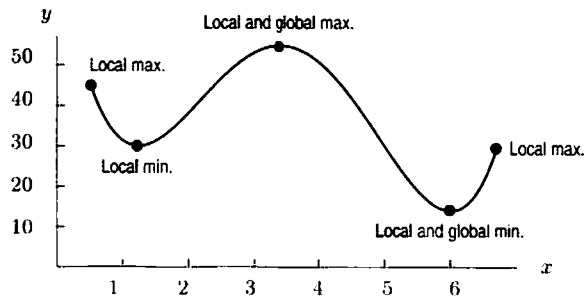

2.

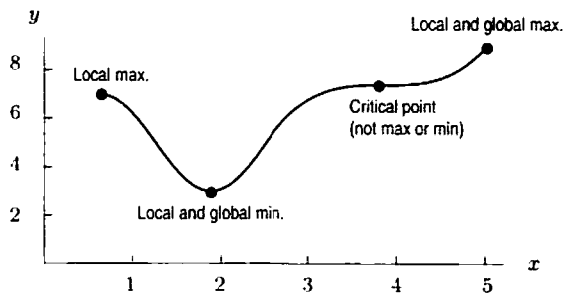

3. (a) Increasing for $x > 0$, decreasing for $x < 0$.
 (b) $f(0)$ is a local and global minimum, and f has no global maximum.
4. (a) Increasing for all x .
 (b) No maxima or minima.
5. (a) Decreasing for $x < 0$, increasing for $0 < x < 4$, and decreasing for $x > 4$.
 (b) $f(0)$ is a local minimum, and $f(4)$ is a local maximum.
6. (a) Decreasing for $x < -1$, increasing for $-1 < x < 0$, decreasing for $0 < x < 1$, and increasing for $x > 1$.
 (b) $f(-1)$ and $f(1)$ are local minima, $f(0)$ is a local maximum.
7. (a) We wish to investigate the behavior of $f(x) = x^3 - 3x^2$ on the interval $-1 \leq x \leq 3$. We find:

$$f'(x) = 3x^2 - 6x = 3x(x - 2)$$

$$f''(x) = 6x - 6 = 6(x - 1)$$

- (b) The critical points of f are $x = 2$ and $x = 0$ since $f'(x) = 0$ at those points. Using the second derivative test, we find that $x = 0$ is a local maximum since $f'(0) = 0$ and $f''(0) = -6 < 0$, and that $x = 2$ is a local minimum since $f'(2) = 0$ and $f''(2) = 6 > 0$.
- (c) There is an inflection point at $x = 1$ since f'' changes sign at $x = 1$.
- (d) At the critical points, $f(0) = 0$ and $f(2) = -4$.
 At the endpoints: $f(-1) = -4$, $f(3) = 0$.
 So the global maxima are $f(0) = 0$ and $f(3) = 0$, while the global minima are $f(-1) = -4$ and $f(2) = -4$.

(e)

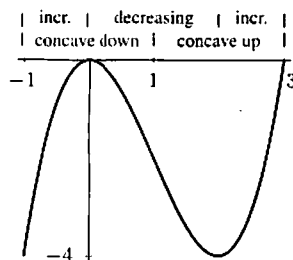

8. (a) First we find f' and f'' ; $f'(x) = 1 + \cos x$ and $f''(x) = -\sin x$.
 (b) The critical point of f is $x = \pi$, since $f'(\pi) = 0$.
 (c) Since f'' changes sign at $x = \pi$, it means that $x = \pi$ is an inflection point.
 (d) Evaluating f at the critical point and endpoints, we find $f(0) = 0$, $f(\pi) = \pi$, $f(2\pi) = 2\pi$. Therefore, the global maximum is $f(2\pi) = 2\pi$, and the global minimum is $f(0) = 0$. Note that $x = \pi$ isn't a local maximum or minimum of f , and that the second derivative test is inconclusive here.
- (e)

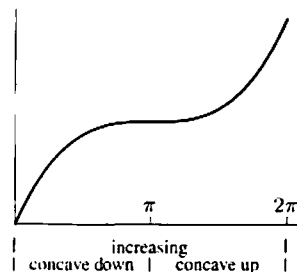

9. (a) First we find f' and f'' :

$$f'(x) = -e^{-x} \sin x + e^{-x} \cos x$$

$$\begin{aligned} f''(x) &= e^{-x} \sin x - e^{-x} \cos x \\ &\quad - e^{-x} \cos x - e^{-x} \sin x \\ &= -2e^{-x} \cos x \end{aligned}$$

- (b) The critical points are $x = \pi/4, 5\pi/4$, since $f'(x) = 0$ here.

- (c) The inflection points are $x = \pi/2, 3\pi/2$, since f'' changes sign at these points.
 (d) At the endpoints, $f(0) = 0, f(2\pi) = 0$. So we have $f(\pi/4) = (e^{-\pi/4})(\sqrt{2}/2)$ as the global maximum; $f(5\pi/4) = -e^{-5\pi/4}(\sqrt{2}/2)$ as the global minimum.
 (e)

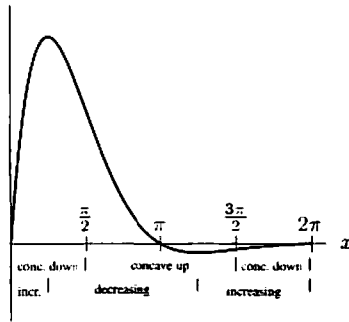

10. (a) We first find f' and f'' :

$$f'(x) = -\frac{2}{3}x^{-5/3} + \frac{1}{3}x^{-2/3} = \frac{1}{3}x^{-5/3}(x - 2)$$

$$f''(x) = \frac{10}{9}x^{-8/3} - \frac{2}{9}x^{-5/3} = -\frac{2}{9}x^{-8/3}(x - 5)$$

- (b) Critical point: $x = 2$.
 (c) There are no inflection points, since f'' does not change sign on the interval $1.2 \leq x \leq 3.5$.
 (d) At the endpoints, $f(1.2) \approx 1.94821$ and $f(3.5) \approx 1.95209$. So, the global minimum is $f(2) \approx 1.88988$ and the global maximum is $f(3.5) \approx 1.95209$.
 (e)

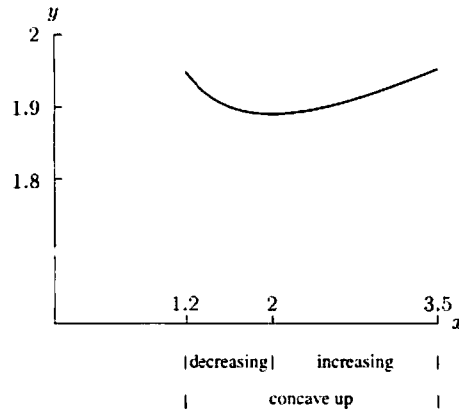

11. The polynomial $f(x)$ behaves like $2x^3$ as x goes to ∞ . Therefore, $\lim_{x \rightarrow \infty} f(x) = \infty$ and $\lim_{x \rightarrow -\infty} f(x) = -\infty$.

We have $f'(x) = 6x^2 - 18x + 12 = 6(x - 2)(x - 1)$, which is zero when $x = 1$ or $x = 2$.

Also, $f''(x) = 12x - 18 = 6(2x - 3)$, which is zero when $x = 3/2$. For $x < 3/2$, $f''(x) < 0$; for $x > 3/2$, $f''(x) > 0$. Thus $x = 3/2$ is an inflection point.

The critical points are $x = 1$ and $x = 2$, and $f(1) = 6, f(2) = 5$. By the second derivative test, $f''(1) = -6 < 0$, so $x = 1$ is a local maximum; $f''(2) = 6 > 0$, so $x = 2$ is a local minimum.

Now we can draw the diagrams below.

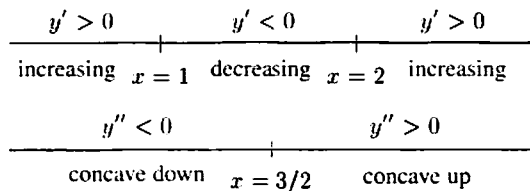

The graph of $f(x) = 2x^3 - 9x^2 + 12x + 1$ is shown below. It has no global maximum or minimum.

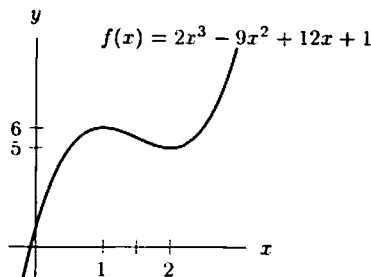

12. If we divide the denominator and numerator of $f(x)$ by x^2 we have

$$\lim_{x \rightarrow \pm\infty} \frac{4x^2}{x^2 + 1} = \lim_{x \rightarrow \pm\infty} \frac{4}{1 + \frac{1}{x^2}} = 4$$

since

$$\lim_{x \rightarrow \pm\infty} \frac{1}{x^2} = 0.$$

Using the quotient rule we get

$$f'(x) = \frac{(x^2 + 1)8x - 4x^2(2x)}{(x^2 + 1)^2} = \frac{8x}{(x^2 + 1)^2},$$

which is zero when $x = 0$, positive when $x > 0$, and negative when $x < 0$. Thus $f(x)$ has a local minimum when $x = 0$, with $f(0) = 0$.

Because $f'(x) = 8x/(x^2 + 1)^2$, the quotient rule implies that

$$\begin{aligned} f''(x) &= \frac{(x^2 + 1)^2 8 - 8x[2(x^2 + 1)2x]}{(x^2 + 1)^4} \\ &= \frac{8x^2 + 8 - 32x^2}{(x^2 + 1)^3} = \frac{8(1 - 3x^2)}{(x^2 + 1)^3}. \end{aligned}$$

The denominator is always positive, so $f''(x) = 0$ when $x = \pm\sqrt{1/3}$, positive when $-\sqrt{1/3} < x < \sqrt{1/3}$, and negative when $x > \sqrt{1/3}$ or $x < -\sqrt{1/3}$. This gives the diagram

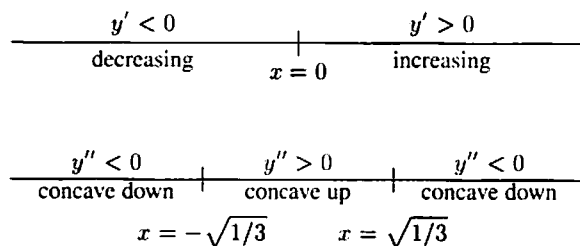

and the graph of f looks like:

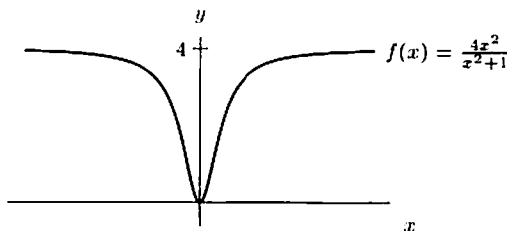

with inflection points $x = \pm\sqrt{1/3}$, a global minimum at $x = 0$, and no local or global maxima (since $f(x)$ never equals 4).

13. As $x \rightarrow -\infty$, $e^{-x} \rightarrow \infty$, so $xe^{-x} \rightarrow -\infty$. Thus $\lim_{x \rightarrow -\infty} xe^{-x} = -\infty$.
 As $x \rightarrow \infty$, $\frac{x}{e^x} \rightarrow 0$, since e^x grows much more quickly than x . Thus $\lim_{x \rightarrow \infty} xe^{-x} = 0$.
 Using the product rule,

$$f'(x) = e^{-x} - xe^{-x} = (1-x)e^{-x},$$

which is zero when $x = 1$, negative when $x > 1$, and positive when $x < 1$. Thus $f(1) = 1/e^1 = 1/e$ is a local maximum.

Again, using the product rule,

$$\begin{aligned} f''(x) &= -e^{-x} - e^{-x} + xe^{-x} \\ &= xe^{-x} - 2e^{-x} \\ &= (x-2)e^{-x}, \end{aligned}$$

which is zero when $x = 2$, positive when $x > 2$, and negative when $x < 2$, giving an inflection point at $(2, \frac{2}{e^2})$. With the above, we have the following diagram:

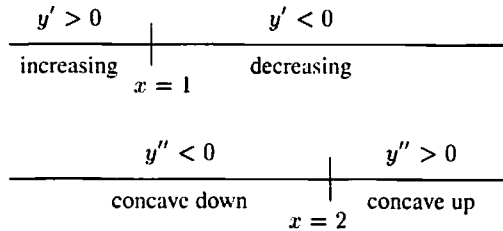

The graph of f is shown below.

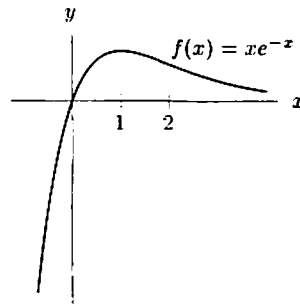

and $f(x)$ has one global maximum at $1/e$ and no local or global minima.

14. $\lim_{x \rightarrow \infty} f(x) = +\infty$, and $\lim_{x \rightarrow -\infty} f(x) = -\infty$.
 There are no asymptotes.

$f'(x) = 3x^2 + 6x - 9 = 3(x+3)(x-1)$. Critical points are $x = -3, x = 1$.
 $f''(x) = 6(x+1)$.

x		-3		-1		1	
f'	+	0	-	-	-	0	+
f''	-	-	-	0	+	+	+
f	↗	↘	↘	↘	↗	↗	↗

Thus, $x = -1$ is an inflection point. $f(-3) = 12$ is a local maximum; $f(1) = -20$ is a local minimum. There are no global maxima or minima.

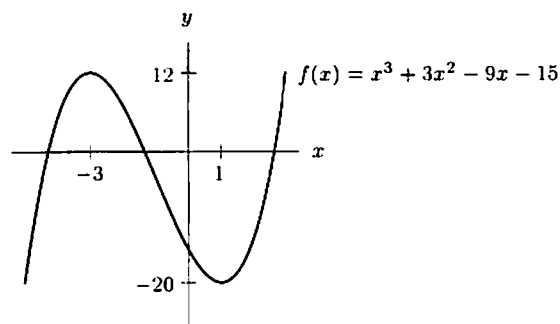

15. $\lim_{x \rightarrow +\infty} f(x) = +\infty$, and $\lim_{x \rightarrow -\infty} f(x) = -\infty$.

There are no asymptotes.

$$f'(x) = 5x^4 - 45x^2 = 5x^2(x^2 - 9) = 5x^2(x+3)(x-3).$$

The critical points are $x = 0$, $x = \pm 3$. f' changes sign at 3 and -3 but not at 0.

$$f''(x) = 20x^3 - 90x = 10x(2x^2 - 9). \quad f'' \text{ changes sign at } 0, \pm 3/\sqrt{2}.$$

So, inflection points are at $x = 0$, $x = \pm 3/\sqrt{2}$.

x		-3		$-3/\sqrt{2}$		0		$3/\sqrt{2}$		3	
f'	+	0	-	-	0	-	-	0	+	0	+
f''	-	-	-	0	+	0	-	0	+	+	+
f		\nearrow		\searrow		\searrow		\searrow		\searrow	\nearrow

Thus, $f(-3)$ is a local maximum; $f(3)$ is a local minimum. There are no global maxima or minima.

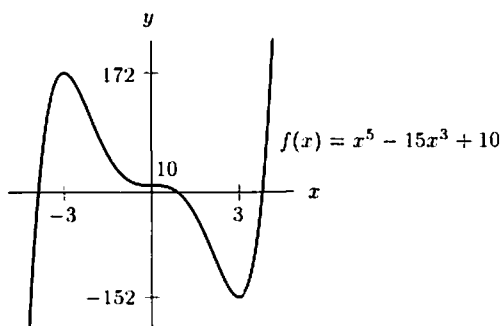

16. $\lim_{x \rightarrow +\infty} f(x) = +\infty$, and $\lim_{x \rightarrow 0^+} f(x) = +\infty$.

Hence, $x = 0$ is a vertical asymptote.

$$f'(x) = 1 - \frac{2}{x} = \frac{x-2}{x}, \text{ so } x = 2 \text{ is the only critical point.}$$

$$f''(x) = \frac{2}{x^2}, \text{ which can never be zero. So there are no inflection points.}$$

x		2	
f'	-	0	+
f''	+	+	+
f	\searrow		\nearrow

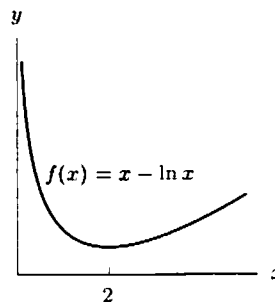

Thus, $f(2)$ is a local and global minimum.

17. $\lim_{x \rightarrow +\infty} f(x) = +\infty, \lim_{x \rightarrow -\infty} f(x) = 0.$
 $y = 0$ is the horizontal asymptote.
 $f'(x) = 2xe^{5x} + 5x^2e^{5x} = xe^{5x}(5x + 2).$
 Thus, $x = -\frac{2}{5}$ and $x = 0$ are the critical points.

$$f''(x) = 2e^{5x} + 2xe^{5x} \cdot 5 + 10xe^{5x} + 25x^2e^{5x} = e^{5x}(25x^2 + 20x + 2).$$

So, $x = \frac{-2 \pm \sqrt{2}}{5}$ are inflection points. So, $f(-\frac{2}{5})$ is a local maximum; $f(0)$ is a local and global minimum.

18. Since $\lim_{x \rightarrow -\infty} f(x) = \lim_{x \rightarrow +\infty} f(x) = 0, y = 0$ is a horizontal asymptote.
 $f'(x) = -2xe^{-x^2}.$ So, $x = 0$ is the only critical point.
 $f''(x) = -2(e^{-x^2} + x(-2x)e^{-x^2}) = 2e^{-x^2}(2x^2 - 1) = 2e^{-x^2}(\sqrt{2}x - 1)(\sqrt{2}x + 1).$
 Thus, $x = \pm 1/\sqrt{2}$ are inflection points.

Table 4.1

x		$-1/\sqrt{2}$		0		$1/\sqrt{2}$	
f'	+	+	+	0	-	-	-
f''	+	0	-	-	-	0	+
f							

Thus, $f(0) = 1$ is a local and global maximum.

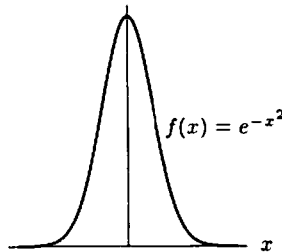

19. $\lim_{x \rightarrow +\infty} f(x) = \lim_{x \rightarrow -\infty} f(x) = 1.$
 Thus, $y = 1$ is a horizontal asymptote. Since $x^2 + 1$ is never 0, there are no vertical asymptotes.

$$f'(x) = \frac{2x(x^2 + 1) - x^2(2x)}{(x^2 + 1)^2} = \frac{2x}{(x^2 + 1)^2}.$$

So, $x = 0$ is the only critical point.

$$f''(x) = \frac{2(x^2 + 1)^2 - 2x \cdot 2(x^2 + 1) \cdot 2x}{(x^2 + 1)^4} = \frac{2(x^2 + 1 - 4x^2)}{(x^2 + 1)^3} = \frac{2(1 - 3x^2)}{(x^2 + 1)^3}.$$

So, $x = \pm \frac{1}{\sqrt{3}}$ are inflection points.

Table 4.2

x		$-\frac{1}{\sqrt{3}}$		0		$\frac{1}{\sqrt{3}}$	
f'	-	-	-	0	+	+	+
f''	-	0	+	+	+	0	-
f							

Thus, $f(0) = 0$ is a local and global minimum. A graph of $f(x)$ can be found in Figure 4.66.

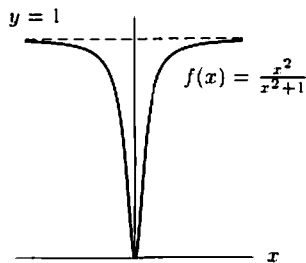

Figure 4.66

Problems

20. Differentiating gives

$$\frac{dy}{dx} = a(e^{-bx} - bxe^{-bx}) = ae^{-bx}(1 - bx).$$

Thus, $dy/dx = 0$ when $x = 1/b$. Then

$$y = a \frac{1}{b} e^{-b \cdot 1/b} = \frac{a}{b} e^{-1}.$$

Differentiating again gives

$$\begin{aligned} \frac{d^2y}{dx^2} &= -abe^{-bx}(1 - bx) - abe^{-bx} \\ &= -abe^{-bx}(2 - bx) \end{aligned}$$

When $x = 1/b$,

$$\frac{d^2y}{dx^2} = -abe^{-b \cdot 1/b} \left(2 - b \cdot \frac{1}{b}\right) = -abe^{-1}.$$

Therefore the point $\left(\frac{1}{b}, \frac{a}{b}e^{-1}\right)$ is a maximum if a and b are positive. We can make (2. 10) a maximum by setting

$$\frac{1}{b} = 2 \quad \text{so} \quad b = \frac{1}{2}$$

and

$$\frac{a}{b}e^{-1} = \frac{a}{1/2}e^{-1} = 2ae^{-1} = 10 \quad \text{so} \quad a = 5e.$$

Thus $a = 5e$, $b = 1/2$.

21. We want the maximum value of $r(t) = ate^{-bt}$ to be 0.3 ml/sec and to occur at $t = 0.5$ sec. Differentiating gives

$$r'(t) = ae^{-bt} - abte^{-bt}.$$

so $r'(t) = 0$ when

$$ae^{-bt}(1 - bt) = 0 \quad \text{or} \quad t = \frac{1}{b}.$$

Since the maximum occurs at $t = 0.5$, we have

$$\frac{1}{b} = 0.5 \quad \text{so} \quad b = 2.$$

Thus, $r(t) = ate^{-2t}$. The maximum value of r is given by

$$r(0.5) = a(0.5)e^{-2(0.5)} = 0.5ae^{-1}.$$

Since the maximum value of r is 0.3, we have

$$0.5ae^{-1} = 0.3 \quad \text{so} \quad a = \frac{0.3e}{0.5} = 1.63.$$

Thus, $r(t) = 1.63te^{-2t}$ ml/sec.

22. The critical points of f occur where f' is zero. These two points are indicated in the figure below.

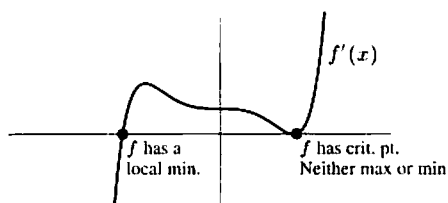

Note that the point labeled as a local minimum of f is not a critical point of f' .

23. (a) The function f is a local maximum where $f'(x) = 0$ and $f' > 0$ to the left, $f' < 0$ to the right. This occurs at the point x_3 .
 (b) The function f is a local minimum where $f'(x) = 0$ and $f' < 0$ to the left, $f' > 0$ to the right. This occurs at the points x_1 and x_5 .
 (c) The graph of f is climbing fastest where f' is a maximum, which is at the point x_2 .
 (d) The graph of f is falling most steeply where f' is the most negative, which is at the point 0.
24. (a)

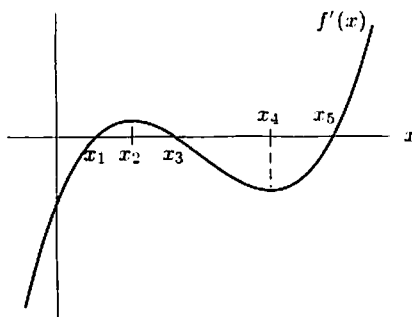

- (b) $f'(x)$ changes sign at x_1 , x_3 , and x_5 .
 (c) $f'(x)$ has local extrema at x_2 and x_4 .
25. The local maxima and minima of f correspond to places where f' is zero and changes sign or, possibly, to the endpoints of intervals in the domain of f . The points at which f changes concavity correspond to local maxima and minima of f' . The change of sign of f' , from positive to negative corresponds to a maximum of f and change of sign of f' from negative to positive corresponds to a minimum of f .
26. To find the critical points, set $dD/dx = 0$:

$$\frac{dD}{dx} = 2(x - a_1) + 2(x - a_2) + 2(x - a_3) + \cdots + 2(x - a_n) = 0.$$

Dividing by 2 and solving for x gives

$$x + x + x + \cdots + x = a_1 + a_2 + a_3 + \cdots + a_n.$$

Since there are n terms on the left,

$$\begin{aligned} nx &= a_1 + a_2 + a_3 + \cdots + a_n \\ x &= \frac{a_1 + a_2 + a_3 + \cdots + a_n}{n} = \frac{1}{n} \sum_{i=1}^n a_i. \end{aligned}$$

The expression on the right is the average of $a_1, a_2, a_3, \dots, a_n$.

Since D is a quadratic with positive leading coefficient, this critical point is a minimum.

27. The volume is given by $V = x^2y$. The surface area is given by

$$\begin{aligned} S &= 2x^2 + 4xy \\ &= 2x^2 + 4xV/x^2 = 2x^2 + 4V/x. \end{aligned}$$

To find the dimensions which minimize the area, find x such that $dS/dx = 0$:

$$\frac{dS}{dx} = 4x - \frac{4V}{x^2} = 0$$

$$x^3 = V.$$

Solving for x gives $x = \sqrt[3]{V} = y$. To see that this gives a minimum, note that for small x , $S \approx 4V/x$ is decreasing. For large x , $S \approx 2x^2$ is increasing. Since there is only one critical point, it must give a global minimum. Therefore, when the width equals the height, the surface area is minimized.

28.

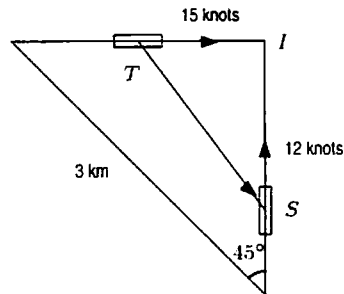

Figure 4.67: Position of the tanker and ship

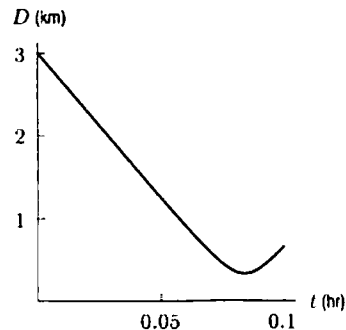

Figure 4.68: Distance between the ship at S and the tanker at T

Suppose t is the time, in hours, since the ships were 3 km apart. Then $\overline{TI} = \frac{3\sqrt{2}}{2} - (15)(1.85)t$ and $\overline{SI} = \frac{3\sqrt{2}}{2} - (12)(1.85)t$. So the distance, $D(t)$, in km, between the ships at time t is

$$D(t) = \sqrt{\left(\frac{3\sqrt{2}}{2} - 27.75t\right)^2 + \left(\frac{3\sqrt{2}}{2} - 22.2t\right)^2}.$$

Differentiating gives

$$\frac{dD}{dt} = \frac{-55.5 \left(\frac{3}{\sqrt{2}} - 27.75t\right) - 44.4 \left(\frac{3}{\sqrt{2}} - 22.2t\right)}{2 \sqrt{\left(\frac{3}{\sqrt{2}} - 27.75t\right)^2 + \left(\frac{3}{\sqrt{2}} - 22.2t\right)^2}}.$$

Solving $dD/dt = 0$ gives a critical point at $t = 0.0839$ hours when the ships will be approximately 331 meters apart. So the ships do not need to change course. Alternatively, tracing along the curve in Figure 4.68 gives the same result. Note that this is after the eastbound ship crosses the path of the northbound ship.

29. Since the volume is fixed at 200 ml (i.e. 200 cm^3), we can solve the volume expression for h in terms of r to get (with h and r in centimeters)

$$h = \frac{200 \cdot 3}{7\pi r^2}.$$

Using this expression in the surface area formula we arrive at

$$S = 3\pi r \sqrt{r^2 + \left(\frac{600}{7\pi r^2}\right)^2}$$

By plotting $S(r)$ we see that there is a minimum value near $r = 2.7$ cm.

30. (a) The business must reorder often enough to keep pace with sales. If reordering is done every t months, then,

$$\text{Quantity sold in } t \text{ months} = \text{Quantity reordered in each batch}$$

$$rt = q$$

$$t = \frac{q}{r} \text{ months.}$$

- (b) The amount spent on each order is $a + bq$, which is spent every q/r months. To find the monthly expenditures, divide by q/r . Thus, on average,

$$\text{Amount spent on ordering per month} = \frac{a + bq}{q/r} = \frac{ra}{q} + rb \text{ dollars.}$$

(c) The monthly cost of storage is $kq/2$ dollars, so

$$C = \text{Ordering costs} + \text{Storage costs}$$

$$C = \frac{ra}{q} + rb + \frac{kq}{2} \text{ dollars.}$$

(d) The optimal batch size minimizes C , so

$$\begin{aligned} \frac{dC}{dq} &= \frac{-ra}{q^2} + \frac{k}{2} = 0 \\ \frac{ra}{q^2} &= \frac{k}{2} \\ q^2 &= \frac{2ra}{k} \end{aligned}$$

so

$$q = \sqrt{\frac{2ra}{k}} \text{ items per order.}$$

31. (a) Consider Figure 4.69. The company wants to truck its potatoes to some point, P , along the coast before transferring them to a ship. Let x represent the distance between that point and the point C . The distance covered by truck is the hypotenuse of the right triangle (provided that it is covered by highway) whose sides have lengths of x and 300 (in miles). This distance is given by

$$\text{Distance in miles covered by truck} = \sqrt{x^2 + 300^2}.$$

The cost of transporting by truck is 2 cents per mile, or $2\sqrt{x^2 + 300^2}$ cents while the cost of transporting by ship is 1 cent per mile, or $1(1000 - x)$ cents. The cost function which we want to minimize, in cents, is therefore

$$C(x) = 2\sqrt{x^2 + 300^2} + (1000 - x).$$

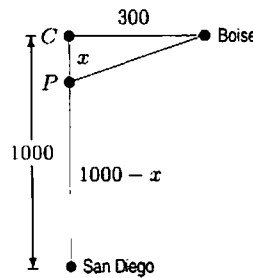

Figure 4.69

(b) To minimize the cost function C , we compute its derivative,

$$\begin{aligned} C'(x) &= (x^2 + 300^2)^{-1/2} \cdot (2x) + (-1) \\ &= \frac{2x}{\sqrt{x^2 + 300^2}} - 1. \end{aligned}$$

When we set $C'(x)$ to 0 to determine the critical point, we get

$$\begin{aligned} \frac{2x}{\sqrt{x^2 + 300^2}} &= 1 \\ 2x &= \sqrt{x^2 + 300^2} \\ 4x^2 &= x^2 + 300^2 \\ 3x^2 &= 300^2 \\ x^2 &= \frac{300^2}{3} = \frac{90000}{3} = 30000 \\ x &= \sqrt{30000} = 173.21 \text{ miles} \end{aligned}$$

Taking the second derivative, we see that

$$C''(x) = \frac{2}{\sqrt{x^2 + 300^2}} - 2x^2(x^2 + 300^2)^{-3/2},$$

which is positive at $x = 173.21$, so the critical point is a minimum. Since there is only one critical point, this must be the global minimum.

32.

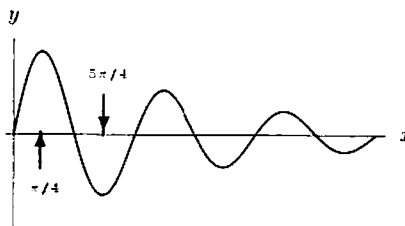

Letting $f(x) = e^{-x} \sin x$, we have

$$f'(x) = -e^{-x} \sin x + e^{-x} \cos x.$$

Solving $f'(x) = 0$, we get $\sin x = \cos x$. This means $x = \arctan(1) = \pi/4$, and $\pi/4$ plus multiples of π , are the critical points of $f(x)$. By evaluating $f(x)$ at the points $k\pi + \pi/4$, where k is an integer, we can find:

$$e^{-5\pi/4} \sin(5\pi/4) \leq e^{-x} \sin x \leq e^{-\pi/4} \sin(\pi/4).$$

since $f(0) = 0$ at the endpoint. So

$$-0.014 \leq e^{-x} \sin x \leq 0.322.$$

33. Let $f(x) = x \sin x$. Then $f'(x) = x \cos x + \sin x$.

$f'(x) = 0$ when $x = 0$, $x \approx 2$, and $x \approx 5$. The latter two estimates we can get from the graph of $f'(x)$.

Zooming in (or using some other approximation method), we can find the zeros of $f'(x)$ with more precision. They are (approximately) 0, 2.029, and 4.913. We check the endpoints and critical points for the global maximum and minimum.

$$\begin{aligned} f(0) &= 0, & f(2\pi) &= 0, \\ f(2.029) &\approx 1.8197, & f(4.914) &\approx -4.814. \end{aligned}$$

Thus for $0 \leq x \leq 2\pi$, $-4.81 \leq f(x) \leq 1.82$.

34. To find the best possible bounds for $f(x) = x^3 - 6x^2 + 9x + 5$ on $0 \leq x \leq 5$, we find the global maximum and minimum for the function on the interval. First, we find the critical points. Differentiating yields

$$f'(x) = 3x^2 - 12x + 9$$

Letting $f'(x) = 0$ and factoring yields

$$\begin{aligned} 3x^2 - 12x + 9 &= 0 \\ 3(x^2 - 4x + 3) &= 0 \\ 3(x-3)(x-1) &= 0 \end{aligned}$$

So $x = 1$ and $x = 3$ are critical points for the function on $0 \leq x \leq 5$. Evaluating the function at the critical points and endpoints gives us

$$\begin{aligned} f(0) &= (0)^3 - 6(0)^2 + 9(0) + 5 = 5 \\ f(1) &= (1)^3 - 6(1)^2 + 9(1) + 5 = 9 \\ f(3) &= (3)^3 - 6(3)^2 + 9(3) + 5 = 5 \\ f(5) &= (5)^3 - 6(5)^2 + 9(5) + 5 = 25 \end{aligned}$$

So the global minimum on this interval is $f(0) = f(3) = 5$ and the global maximum is $f(5) = 25$. From this we conclude

$$5 \leq x^3 - 6x^2 + 9x + 5 \leq 25$$

are the best possible bounds for the function on the interval $0 \leq x \leq 5$.

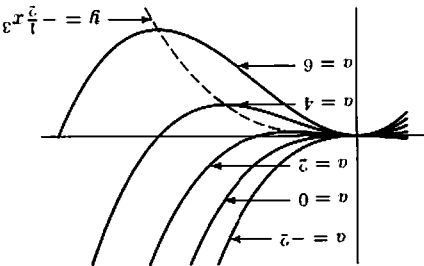

To solve for the critical points, we set $\frac{dy}{dx} = 0$. Since $\frac{dy}{dx} = 3x^2 - 2ax = 3x^2 - 2ax = 0$, so $x = 0$ or $x = \frac{2}{3}a$. At $x = 0$, we have $y = 0$. This first critical point is independent of a and lies on the curve $y = -\frac{2}{3}x^3$. At $x = \frac{2}{3}a$, we calculate $y = -\frac{2}{3}(\frac{2}{3}a)^3 = -\frac{2}{3} \cdot \frac{8}{27}a^3 = -\frac{16}{81}a^3$. Thus the second critical point also lies on the curve $y = -\frac{2}{3}x^3$.

36. (a) x -intercept: $(a, 0)$, y -intercept: $(0, \frac{a^2+1}{1})$
 (b) Area = $\frac{1}{2}(a)(\frac{a^2+1}{1}) = \frac{a^3+a}{2}$
 (c)

$$\begin{aligned} -f &= \frac{2(a^2+1)}{a} \\ f' &= \frac{4(a^2+1) - a(4a)}{2(a^2+1)^2} \\ &= \frac{2(1-a^2)}{2(a^2+1)^2} \\ &= \frac{2(a^2+1)^2}{(1-a^2)^2} \end{aligned}$$

If $f' = 0$, then $a = \pm 1$. We only consider positive values of a , and we note that f' changes sign from positive to negative at $a = 1$. Hence $a = 1$ is a local maximum of f which is a global maximum because $f' < 0$ for all $a > 1$ and $f' > 0$ for $0 < a < 1$.

- (d) $f = \frac{2}{1} (1)(\frac{2}{1}) = \frac{4}{1}$
 (e) Set $\frac{2(a^3+a)}{2} = \frac{3}{1}$ and solve for a :

$$\begin{aligned} 3a &= 2a^2 + 2 \\ 2a^2 - 3a + 2 &= 0 \\ (2a - 1)(a - 2) &= 0. \end{aligned}$$

37. (a) We have $g'(t) = \frac{t(1/t)^2 - \ln t}{(1/t)^2 - \ln t} = \frac{t^2 - \ln t}{1 - \ln t}$, which is zero if $t = e$, negative if $t > e$, and positive if $t < e$, since $\ln t$ is increasing. Thus $g(e) = \frac{e}{1}$ is a global maximum for g . Since $t = e$ was the only point at which $g'(t) = 0$, there is no minimum.

- (b) Now $\ln t/t$ is increasing for $0 < t < e$, $\ln 1/1 = 0$, and $\ln 5/5 \approx 0.322 < \ln(e)/e$. Thus, for $1 < t < e$, $\ln t/t$ increases from 0 to above $\ln 5/5$, so there must be a t between 1 and e such that $\ln t/t = \ln 5/5$. For $t > e$, there is only one solution to $\ln t/t = \ln 5/5$, namely $t = 5$, since $\ln t/t$ is decreasing for $t > e$. For $0 < t < 1$, $\ln t/t$ is negative and so cannot equal $\ln 5/5$. Thus $\ln x/x = \ln 5/5$. Thus $\ln x/x = \ln 5/5$ has exactly two solutions.
- (c) The graph of $\ln t/t$ intersects the horizontal line $y = \ln 5/5$, at $x = 5$ and $x \approx 1.75$.
- (a) The concavity changes at t_1 and t_3 , as shown below.

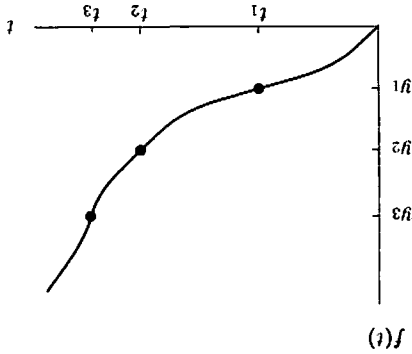

- (b) $f(t)$ grows most quickly where the vase is skinniest (at y_3) and most slowly where the vase is widest (at y_1). The diameter of the widest part of the vase looks to be about 4 times as large as the diameter at the skinniest part. Since the area of a cross section is given by πr^2 , where r is the radius, the ratio between areas of cross sections at these two places is about 4^2 , so the growth rates are in a ratio of about 1 to 16 (the wide part being 16 times slower).

39.

$$r(\lambda) = a(\lambda)^{-5}(e^{b/\lambda} - 1)^{-1}$$

$$r'(\lambda) = a(-5\lambda^{-6})(e^{b/\lambda} - 1)^{-1} + a(\lambda^{-5})\left(\frac{b}{\lambda^2}e^{b/\lambda}\right)(e^{b/\lambda} - 1)^{-2}$$

(0.96, 3.13) is a maximum, so $r'(0.96) = 0$ implies that the following holds, with $\lambda = 0.96$:

$$\begin{aligned} 5\lambda^{-6}(e^{b/\lambda} - 1)^{-1} &= \lambda^{-5}\left(\frac{b}{\lambda^2}e^{b/\lambda}\right)(e^{b/\lambda} - 1)^{-2} \\ 5\lambda(e^{b/\lambda} - 1) &= be^{b/\lambda} \\ 5\lambda e^{b/\lambda} - 5\lambda &= be^{b/\lambda} \\ 5\lambda e^{b/\lambda} - be^{b/\lambda} &= 5\lambda \\ \left(\frac{5\lambda - b}{5\lambda}\right)e^{b/\lambda} &= 1 \\ \frac{4.8 - b}{4.8}e^{b/0.96} - 1 &= 0. \end{aligned}$$

Using Newton's method, or some other approximation method, we search for a root. The root should be near 4.8. Using our initial guess, we get $b \approx 4.7665$. At $\lambda = 0.96$, $r = 3.13$, so

$$\begin{aligned} 3.13 &= \frac{a}{0.96^5(e^{b/0.96} - 1)} \quad \text{or} \\ a &= 3.13(0.96)^5(e^{b/0.96} - 1) \\ &\approx 363.23. \end{aligned}$$

As a check, we try $r(4) \approx 0.155$, which looks about right on the given graph.

40. (a) The length of the piece of wire made into a circle is x cm, so the length of the piece made into a square is $(L - x)$ cm. See Figure 4.70.

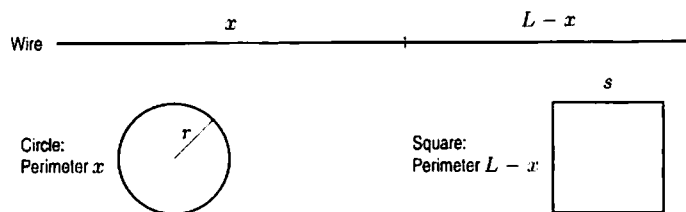

Figure 4.70

The circumference of the circle is x , so its radius, r cm, is given by

$$r = \frac{x}{2\pi} \text{ cm.}$$

The perimeter of the square is $(L - x)$, so the side length, s cm, is given by

$$s = \frac{L - x}{4} \text{ cm.}$$

Thus, the sum of areas is given by

$$A = \pi r^2 + s^2 = \pi \left(\frac{x}{2\pi}\right)^2 + \left(\frac{L-x}{4}\right)^2 = \frac{x^2}{4\pi} + \frac{(L-x)^2}{16}, \quad \text{for } 0 \leq x \leq L.$$

Setting $dA/dx = 0$ to find the critical points gives

$$\begin{aligned}\frac{dA}{dx} &= \frac{x}{2\pi} - \frac{(L-x)}{8} = 0 \\ 8x &= 2\pi L - 2\pi x \\ (8+2\pi)x &= 2\pi L \\ x &= \frac{2\pi L}{8+2\pi} = \frac{\pi L}{4+\pi} \approx 0.44L.\end{aligned}$$

To find the maxima and minima, we substitute the critical point and the endpoints, $x = 0$ and $x = L$, into the area function.

$$\text{For } x = 0, \text{ we have } A = \frac{L^2}{16}.$$

$$\text{For } x = \frac{\pi L}{4+\pi}, \text{ we have } L-x = L - \frac{\pi L}{4+\pi} = \frac{4L}{4+\pi}. \text{ Then}$$

$$\begin{aligned}A &= \frac{\pi^2 L^2}{4\pi(4+\pi)^2} + \frac{1}{16} \left(\frac{4L}{4+\pi} \right)^2 = \frac{\pi L^2}{4(4+\pi)^2} + \frac{L^2}{(4+\pi)^2} \\ &= \frac{\pi L^2 + 4L^2}{4(4+\pi)^2} = \frac{L^2}{4(4+\pi)} = \frac{L^2}{16+4\pi}.\end{aligned}$$

$$\text{For } x = L, \text{ we have } A = \frac{L^2}{4\pi}.$$

$$\text{Thus, } x = \frac{\pi L}{4+\pi} \text{ gives the minimum value of } A = \frac{L^2}{16+4\pi}.$$

$$\text{Since } 4\pi < 16, \text{ we see that } x = L \text{ gives the maximum value of } A = \frac{L^2}{4\pi}.$$

This corresponds to the situation in which we do not cut the wire at all and use the single piece to make a circle.

(b) At the maximum, $x = L$, so

$$\frac{\text{Length of wire in square}}{\text{Length of wire in circle}} = \frac{0}{L} = 0.$$

$$\frac{\text{Area of square}}{\text{Area of circle}} = \frac{0}{L^2/4\pi} = 0.$$

$$\text{At the minimum, } x = \frac{\pi L}{4+\pi}, \text{ so } L-x = L - \frac{\pi L}{4+\pi} = \frac{4L}{4+\pi}.$$

$$\frac{\text{Length of wire in square}}{\text{Length of wire in circle}} = \frac{4L/(4+\pi)}{\pi L/(4+\pi)} = \frac{4}{\pi}.$$

$$\frac{\text{Area of square}}{\text{Area of circle}} = \frac{L^2/(4+\pi)^2}{\pi L^2/(4(4+\pi)^2)} = \frac{4}{\pi}.$$

(c) For a general value of x ,

$$\frac{\text{Length of wire in square}}{\text{Length of wire in circle}} = \frac{L-x}{x}.$$

$$\frac{\text{Area of square}}{\text{Area of circle}} = \frac{(L-x)^2/16}{x^2/(4\pi)} = \frac{\pi}{4} \cdot \frac{(L-x)^2}{x^2}.$$

If the ratios are equal, we have

$$\frac{L-x}{x} = \frac{\pi}{4} \cdot \frac{(L-x)^2}{x^2}.$$

So either $L-x = 0$, giving $x = L$, or we can cancel $(L-x)$ and multiply through by $4x^2$, giving

$$4x = \pi(L-x)$$

$$x = \frac{\pi L}{4+\pi}.$$

Thus, the two values of x found in part (a) are the only values of x in $0 \leq x \leq L$ making the ratios in part (b) equal. (The ratios are not defined if $x = 0$.)

CAS Challenge Problems

41. (a) Since $k > 0$, we have $\lim_{t \rightarrow \infty} e^{-kt} = 0$. Thus

$$\lim_{t \rightarrow \infty} P = \lim_{t \rightarrow \infty} \frac{L}{1 + Ce^{-kt}} = \frac{L}{1 + C \cdot 0} = L.$$

The constant L is called the carrying capacity of the environment because it represents the long-run population in the environment.

- (b) Using a CAS, we find

$$\frac{d^2P}{dt^2} = -\frac{LCk^2e^{-kt}(1 - Ce^{-kt})}{(1 + Ce^{-kt})^3}.$$

Thus, $d^2P/dt^2 = 0$ when

$$\begin{aligned} 1 - Ce^{-kt} &= 0 \\ t &= -\frac{\ln(1/C)}{k}. \end{aligned}$$

Since e^{-kt} and $(1 + Ce^{-kt})$ are both always positive, the sign of d^2P/dt^2 is negative when $(1 - Ce^{-kt}) > 0$, that is, for $t > -\ln(1/C)/k$. Similarly, the sign of d^2P/dt^2 is positive when $(1 - Ce^{-kt}) < 0$, that is, for $t < -\ln(1/C)/k$. Thus, there is an inflection point at $t = -\ln(1/C)/k$.

For $t = -\ln(1/C)/k$,

$$P = \frac{L}{1 + Ce^{\ln(1/C)}} = \frac{L}{1 + C(1/C)} = \frac{L}{2}.$$

Thus, the inflection point occurs where $P = L/2$.

42. (a) The graph has a jump discontinuity whose position depends on a . The function is increasing, and the slope at a given x -value seems to be the same for all values of a . See Figure 4.71.

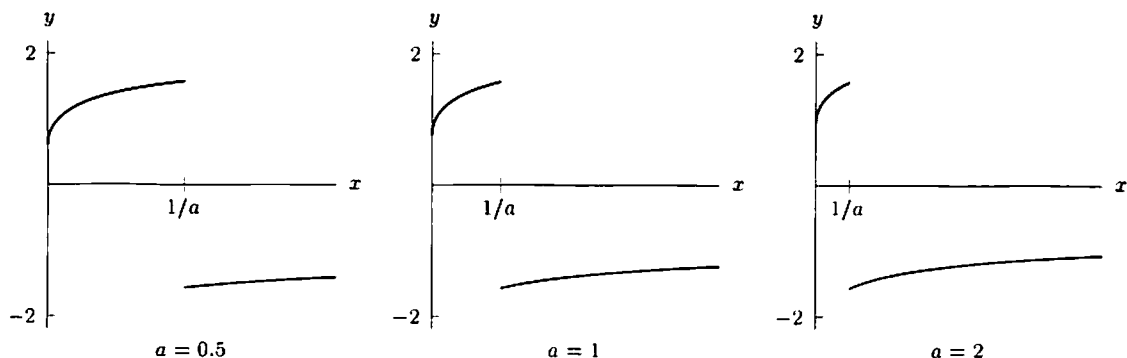

Figure 4.71

- (b) Most computer algebra systems will give a fairly complicated answer for the derivative. Here is one example; others may be different.

$$\frac{dy}{dx} = \frac{\sqrt{x} + \sqrt{a}\sqrt{ax}}{2x(1 + a + 2\sqrt{a}\sqrt{x} + x + ax - 2\sqrt{ax})}.$$

When we graph the derivative, it appears that we get the same graph for all values of a . See Figure 4.72.

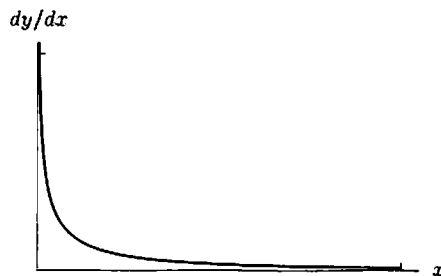

Figure 4.72

- (c) Since a and x are positive, we have $\sqrt{ax} = \sqrt{a}\sqrt{x}$. We can use this to simplify the expression we found for the derivative:

$$\begin{aligned}\frac{dy}{dx} &= \frac{\sqrt{x} + \sqrt{a}\sqrt{ax}}{2x(1+a+2\sqrt{a}\sqrt{x}+x+ax-2\sqrt{ax})} \\ &= \frac{\sqrt{x} + \sqrt{a}\sqrt{a}\sqrt{x}}{2x(1+a+2\sqrt{a}\sqrt{x}+x+ax-2\sqrt{a}\sqrt{x})} \\ &= \frac{\sqrt{x} + a\sqrt{x}}{2x(1+a+x+ax)} = \frac{(1+a)\sqrt{x}}{2x(1+a)(1+x)} = \frac{\sqrt{x}}{2x(1+x)}\end{aligned}$$

Since a has canceled out, the derivative is independent of a . This explains why all the graphs look the same in part (b). (In fact they are not exactly the same, because $f'(x)$ is undefined where $f(x)$ has its jump discontinuity. The point at which this happens changes with a .)

43. (a) A CAS gives

$$\frac{d}{dx} \operatorname{arcsinh} x = \frac{1}{\sqrt{1+x^2}}$$

- (b) Differentiating both sides of $\sinh(\operatorname{arcsinh} x) = x$, we get

$$\begin{aligned}\cosh(\operatorname{arcsinh} x) \frac{d}{dx}(\operatorname{arcsinh} x) &= 1 \\ \frac{d}{dx}(\operatorname{arcsinh} x) &= \frac{1}{\cosh(\operatorname{arcsinh} x)}.\end{aligned}$$

Since $\cosh^2 x - \sinh^2 x = 1$, $\cosh x = \pm\sqrt{1+\sinh^2 x}$. Furthermore, since $\cosh x > 0$ for all x , we take the positive square root, so $\cosh x = \sqrt{1+\sinh^2 x}$. Therefore, $\cosh(\operatorname{arcsinh} x) = \sqrt{1+(\sinh(\operatorname{arcsinh} x))^2} = \sqrt{1+x^2}$. Thus

$$\frac{d}{dx} \operatorname{arcsinh} x = \frac{1}{\sqrt{1+x^2}}.$$

44. (a) A CAS gives

$$\frac{d}{dx} \operatorname{arccosh} x = \frac{1}{\sqrt{x^2-1}}, \quad x \geq 1.$$

- (b) Differentiating both sides of $\cosh(\operatorname{arccosh} x) = x$, we get

$$\begin{aligned}\sinh(\operatorname{arccosh} x) \frac{d}{dx}(\operatorname{arccosh} x) &= 1 \\ \frac{d}{dx}(\operatorname{arccosh} x) &= \frac{1}{\sinh(\operatorname{arccosh} x)}.\end{aligned}$$

Since $\cosh^2 x - \sinh^2 x = 1$, $\sinh x = \pm\sqrt{\cosh^2 x - 1}$. If $x \geq 0$, then $\sinh x \geq 0$, so we take the positive square root. So $\sinh x = \sqrt{\cosh^2 x - 1}$, $x \geq 0$. Therefore, $\sinh(\operatorname{arccosh} x) = \sqrt{(\cosh(\operatorname{arccosh} x))^2 - 1} = \sqrt{x^2 - 1}$, for $x \geq 1$. Thus

$$\frac{d}{dx} \operatorname{arccosh} x = \frac{1}{\sqrt{x^2-1}}.$$

45. (a) Using a computer algebra system or differentiating by hand, we get

$$f'(x) = \frac{1}{2\sqrt{a+x}(\sqrt{a}+\sqrt{x})} - \frac{\sqrt{a+x}}{2\sqrt{x}(\sqrt{a}+\sqrt{x})^2}.$$

Simplifying gives

$$f'(x) = \frac{-a + \sqrt{a}\sqrt{x}}{2(\sqrt{a}+\sqrt{x})^2\sqrt{x}\sqrt{a+x}}.$$

The denominator of the derivative is always positive if $x > 0$, and the numerator is zero when $x = a$. Writing the numerator as $\sqrt{a}(\sqrt{x} - \sqrt{a})$, we see that the derivative changes from negative to positive at $x = a$. Thus, by the first derivative test, the function has a local minimum at $x = a$.

- (b) As a increases, the local minimum moves to the right. See Figure 4.73. This is consistent with what we found in part (a), since the local minimum is at $x = a$.

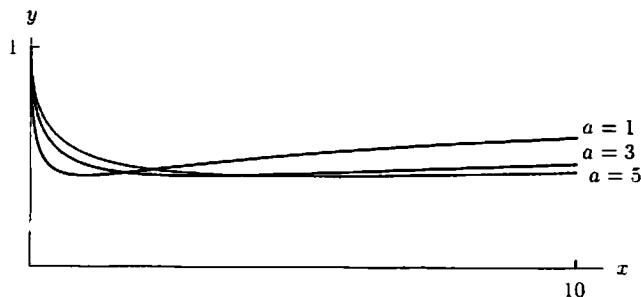

Figure 4.73

- (c) Using a computer algebra system to find the second derivative when $a = 2$, we get

$$f''(x) = \frac{4\sqrt{2} + 12\sqrt{x} + 6x^{3/2} - 3\sqrt{2}x^2}{4(\sqrt{2} + \sqrt{x})^3 x^{3/2} (2+x)^{3/2}}.$$

Using the computer algebra system again to solve $f''(x) = 0$, we find that it has one zero at $x = 4.6477$. Graphing the second derivative, we see that it goes from positive to negative at $x = 4.6477$, so this is an inflection point.

46. (a) Different CASs give different answers. (In fact, their answers could be more complicated than what you get by hand.) One possible answer is

$$\frac{dy}{dx} = \frac{\tan\left(\frac{x}{2}\right)}{2\sqrt{\frac{1-\cos x}{1+\cos x}}}.$$

- (b) The graph in Figure 4.74 is a step function:

$$f(x) = \begin{cases} 1/2 & 2n\pi < x < (2n+1)\pi \\ -1/2 & (2n+1)\pi < x < (2n+2)\pi. \end{cases}$$

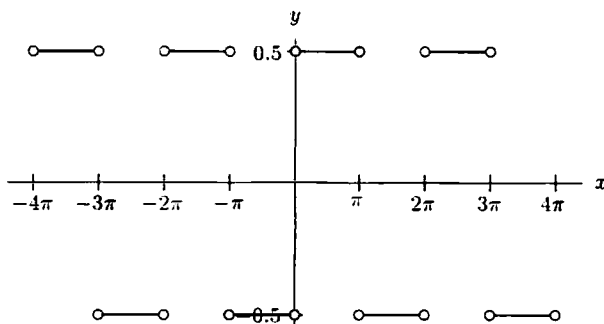

Figure 4.74

Figure 4.74, which shows the graph in disconnected line segments, is correct. However, unless you select certain graphing options in your CAS, it may join up the segments. Use the double angle formula $\cos(x) = \cos^2(x/2) - \sin^2(x/2)$ to simplify the answer in part (a). We find

$$\begin{aligned} \frac{dy}{dx} &= \frac{\tan(x/2)}{2\sqrt{\frac{1-\cos x}{1+\cos x}}} = \frac{\tan(x/2)}{2\sqrt{\frac{1-\cos(2\cdot(x/2))}{1+\cos(2\cdot(x/2))}}} = \frac{\tan(x/2)}{2\sqrt{\frac{1-\cos^2(x/2)+\sin^2(x/2)}{1+\cos^2(x/2)-\sin^2(x/2)}}} \\ &= \frac{\tan(x/2)}{2\sqrt{\frac{2\sin^2(x/2)}{2\cos^2(x/2)}}} = \frac{\tan(x/2)}{2\sqrt{\tan^2(x/2)}} = \frac{\tan(x/2)}{2|\tan(x/2)|} \end{aligned}$$

Thus, $dy/dx = 1/2$ when $\tan(x/2) > 0$, i.e. when $0 < x < \pi$ (more generally, when $2n\pi < x < (2n+1)\pi$), and $dy/dx = -1/2$ when $\tan(x/2) < 0$, i.e., when $\pi < x < 2\pi$ (more generally, when $(2n+1)\pi < x < (2n+2)\pi$, where n is any integer).

47. (a)

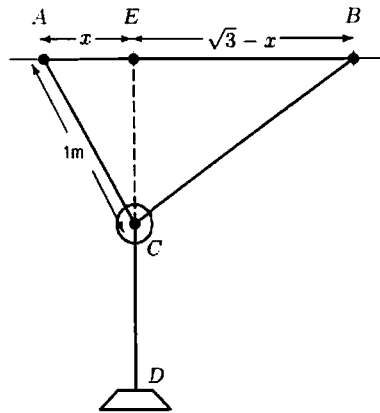

Figure 4.75

We want to maximize the sum of the lengths EC and CD in Figure 4.75. Let x be the distance AE . Then x can be between 0 and 1, the length of the left rope. By the Pythagorean theorem,

$$EC = \sqrt{1 - x^2}.$$

The length of the rope from B to C can also be found by the Pythagorean theorem:

$$BC = \sqrt{EC^2 + EB^2} = \sqrt{1 - x^2 + (\sqrt{3} - x)^2} = \sqrt{4 - 2\sqrt{3}x}.$$

Since the entire rope from B to D has length 3 m, the length from C to D is

$$CD = 3 - \sqrt{4 - 2\sqrt{3}x}.$$

The distance we want to maximize is

$$f(x) = EC + CD = \sqrt{1 - x^2} + 3 - \sqrt{4 - 2\sqrt{3}x}, \quad \text{for } 0 \leq x \leq 1.$$

Differentiating gives

$$f'(x) = \frac{-2x}{2\sqrt{1 - x^2}} - \frac{-2\sqrt{3}}{2\sqrt{4 - 2\sqrt{3}x}}.$$

Setting $f'(x) = 0$ gives the cubic equation

$$2\sqrt{3}x^3 - 7x^2 + 3 = 0.$$

Using a computer algebra system to solve the equation gives three roots: $x = -1/\sqrt{3}$, $x = \sqrt{3}/2$, $x = \sqrt{3}$. We discard the negative root. Since x cannot be larger than 1 meter (the length of the left rope), the only critical point of interest is $x = \sqrt{3}/2$, that is, halfway between A and B .

To find the global maximum, we calculate the distance of the weight from the ceiling at the critical point and at the endpoints:

$$\begin{aligned} f(0) &= \sqrt{1} + 3 - \sqrt{4} = 2 \\ f\left(\frac{\sqrt{3}}{2}\right) &= \sqrt{1 - \frac{3}{4}} + 3 - \sqrt{4 - 2\sqrt{3} \cdot \frac{\sqrt{3}}{2}} = 2.5 \\ f(1) &= \sqrt{0} + 3 - \sqrt{4 - 2\sqrt{3}} = 4 - \sqrt{3} = 2.27. \end{aligned}$$

Thus, the weight is at the maximum distance from the ceiling when $x = \sqrt{3}/2$; that is, the weight comes to rest at a point halfway between points A and B .

- (b) No, the equilibrium position depends on the length of the rope. For example, suppose that the left-hand rope was 1 cm long. Then there is no way for the pulley at its end to move to a point halfway between the anchor points.

CHECK YOUR UNDERSTANDING

- True. Since the domain of f is all real numbers, all local minima occur at critical points.
- True. Since the domain of f is all real numbers, all local maxima occur at critical points. Thus, if $x = p$ is a local maximum, $x = p$ must be a critical point.
- False. A local maximum of f might occur at a point where f' does not exist. For example, $f(x) = -|x|$ has a local maximum at $x = 0$, but the derivative is not 0 (or defined) there.
- False, because $x = p$ could be a local minimum of f . For example, if $f(x) = x^2$, then $f'(0) = 0$, so $x = 0$ is a critical point, but $x = 0$ is not a local maximum of f .
- False. For example, if $f(x) = x^3$, then $f'(0) = 0$, but $f(x)$ does not have either a local maximum or a local minimum at $x = 0$.
- True. Suppose f is increasing at some points and decreasing at others. Then $f'(x)$ takes both positive and negative values. Since $f'(x)$ is continuous, by the Intermediate Value Theorem, there would be some point where $f'(x)$ is zero, so that there would be a critical point. Since we are told there are no critical points, f must be increasing everywhere or decreasing everywhere.
- False. For example, if $f(x) = x^4$, then $f''(x) = 12x^2$, and hence $f''(0) = 0$. But f does not have an inflection point at $x = 0$ because the second derivative does not change sign at 0.
- True. Since f'' changes sign at the inflection point $x = p$, by the Intermediate Value Theorem, $f''(p) = 0$.
- True, by the Increasing Function Theorem, Theorem 4.4.
- False. For example, let $f(x) = x + 5$, and $g(x) = 2x - 3$. Then $f'(x) \leq g'(x)$ for all x , but $f(0) > g(0)$.
- False. For example, let $f(x) = 3x + 1$ and $g(x) = 3x + 7$.
- False. For example, if $f(x) = -x$, then $f'(x) \leq 1$ for all x , but $f(-2) = 2$, so $f(-2) > -2$.
- Let $f(x) = ax^2$, with $a \neq 0$. Then $f'(x) = 2ax$, so f has a critical point only at $x = 0$.
- Let $g(x) = ax^3 + bx^2$, where neither a nor b are allowed to be zero. Then

$$g'(x) = 3ax^2 + 2bx = x(3ax + 2b).$$

Then $g(x)$ has two distinct critical points, at $x = 0$ and at $x = -2b/3a$. Since

$$g''(x) = 6ax + 2b,$$

there is exactly one point of inflection, $x = -2b/6a = -b/3a$.

- The function $f(x) = |x|$ is continuous on $[-1, 1]$, but there is no number c , with $-1 < c < 1$, such that

$$f'(c) = \frac{|1| - |-1|}{1 - (-1)} = 0;$$

that is, the slope of $f(x) = |x|$ is never 0.

- Let f be defined by

$$f(x) = \begin{cases} x & \text{if } 0 \leq x < 2 \\ 19 & \text{if } x = 2 \end{cases}$$

Then f is differentiable on $(0, 2)$ and $f'(x) = 1$ for all x in $(0, 2)$. Thus there is no c in $(0, 2)$ such that

$$f'(c) = \frac{f(2) - f(0)}{2 - 0} = \frac{19}{2}.$$

The reason that this function does not satisfy the conclusion of the Mean Value Theorem is that it is not continuous at $x = 2$.

- Let f be defined by

$$f(x) = \begin{cases} x^2 & \text{if } 0 \leq x < 1 \\ 1/2 & \text{if } x = 1. \end{cases}$$

Then f is not continuous at $x = 1$, but f is differentiable on $(0, 1)$ and $f'(x) = 2x$ for $0 < x < 1$. Thus, $c = 1/4$ satisfies

$$f'(c) = \frac{f(1) - f(0)}{1 - 0} = \frac{1}{2}, \quad \text{since} \quad f'\left(\frac{1}{4}\right) = 2 \cdot \frac{1}{4} = \frac{1}{2}.$$

18. (a) True. $f(x) \leq 4$ on the interval $(0, 2)$
 (b) False. The values of $f(x)$ get arbitrarily close to 4, but $f(x) < 4$ for all x in the interval $(0, 2)$.
 (c) True. The values of $f(x)$ get arbitrarily close to 0, but $f(x) > 0$ for all x in the interval $(0, 2)$.
 (d) False. On the interval $(-1, 1)$, the global minimum is 0.
 (e) True, by the Extreme Value Theorem, Theorem 4.2.
19. (a) This is not implied; just because a function satisfies the conclusions of the statement, that does not mean it has to satisfy the conditions.
 (b) This is not implied; if a function fails to satisfy the conditions of the statement, then the statement doesn't tell us anything about it.
 (c) This is implied; if a function fails to satisfy the conclusions of the statement, then it couldn't satisfy the conditions of the statement, because if it did the statement would imply it also satisfied the conclusions.
20. $f(x) = x^2 + 1$ is positive for all x and concave up.
21. This is impossible. If $f(a) > 0$, then the downward concavity forces the graph of f to cross the x -axis to the right or left of $x = a$, which means $f(x)$ cannot be positive for all values of x . More precisely, suppose that $f(x)$ is positive for all x and f is concave down. Thus there must be some value $x = a$ where $f(a) > 0$ and $f'(a)$ is not zero, since a constant function is not concave down. The tangent line at $x = a$ has nonzero slope and hence must cross the x -axis somewhere to the right or left of $x = a$. Since the graph of f must lie below this tangent line, it must also cross the x -axis, contradicting the assumption that $f(x)$ is positive for all x .
22. $f(x) = -x^2 - 1$ is negative for all x and concave down.
23. This is impossible. If $f(a) < 0$, then the upward concavity forces the graph of f to cross the x -axis to the right or left of $x = a$, which means $f(x)$ cannot be negative for all values of x . More precisely, suppose that $f(x)$ is negative for all x and f is concave up. Thus there must be some value $x = a$ where $f(a) < 0$ and $f'(a)$ is not zero, since a constant function is not concave up. The tangent line at $x = a$ has nonzero slope and hence must cross the x -axis somewhere to the right or left of $x = a$. Since the graph of f must lie above this tangent line, it must also cross the x -axis, contradicting the assumption that $f(x)$ is negative for all x .
24. This is impossible. Since f'' exists, so must f' , which means that f is differentiable and hence continuous. If $f(x)$ were positive for some values of x and negative for other values, then by the Intermediate Value Theorem, $f(x)$ would have to be zero somewhere, but this is impossible since $f(x)f''(x) < 0$ for all x . Thus either $f(x) > 0$ for all values of x , in which case $f''(x) < 0$ for all values of x , that is f is concave down. But this is impossible by Problem 21. Or else $f(x) < 0$ for all x , in which case $f''(x) > 0$ for all x , that is f is concave up. But this is impossible by Problem 23.
25. This is impossible. Since f''' exists, f'' must be continuous. By the Intermediate Value Theorem, $f''(x)$ cannot change sign, since $f''(x)$ cannot be zero. In the same way, we can show that $f'(x)$ and $f(x)$ cannot change sign. Since the product of these three with $f'''(x)$ cannot change sign, $f'''(x)$ cannot change sign. Thus $f(x)f''(x)$ and $f'(x)f'''(x)$ cannot change sign. Since their product is negative for all x , one or the other must be negative for all x . By Problem 24, this is impossible.

PROJECTS FOR CHAPTER FOUR

1.

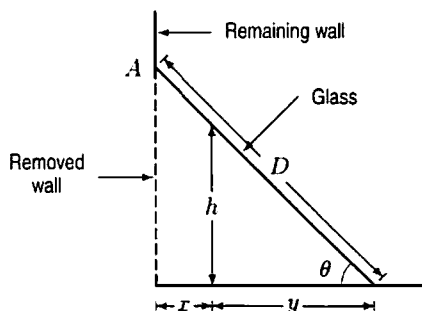

Figure 4.76: A Cross-section of the Projected Greenhouse

Suppose that the glass is at an angle θ (as shown in Figure 4.76), that the length of the wall is l , and that the glass has dimensions D ft by l ft. Since your parents will spend a fixed amount, the area of the glass, say

$k \text{ ft}^2$, is fixed:

$$Dl = k.$$

The width of the extension is $D \cos \theta$. If h is the height of your tallest parent, he or she can walk in a distance of x , and

$$\frac{h}{y} = \tan \theta, \quad \text{so} \quad y = \frac{h}{\tan \theta}.$$

Thus,

$$x = D \cos \theta - y = D \cos \theta - \frac{h}{\tan \theta} \quad \text{for } 0 < \theta < \frac{\pi}{2}.$$

We maximize x since doing so maximizes the usable area:

$$\frac{dx}{d\theta} = -D \sin \theta + \frac{h}{(\tan \theta)^2} \cdot \frac{1}{(\cos \theta)^2} = 0$$

$$\sin^3 \theta = \frac{h}{D}$$

$$\theta = \arcsin \left(\left(\frac{h}{D} \right)^{1/3} \right).$$

This is the only critical point, and $x \rightarrow 0$ when $\theta \rightarrow 0$ and when $\theta \rightarrow \pi/2$. Thus, the critical point is a global maximum. Since

$$\cos \theta = \sqrt{1 - \sin^2 \theta} = \sqrt{1 - \left(\frac{h}{D} \right)^{2/3}}.$$

the maximum value of x is

$$\begin{aligned} x &= D \cos \theta - \frac{h}{\tan \theta} = D \cos \theta - \frac{h \cos \theta}{\sin \theta} \\ &= \left(D - \frac{h}{\sin \theta} \right) \cos \theta = \left(D - \frac{h}{(h/D)^{1/3}} \right) \cdot \left(1 - \left(\frac{h}{D} \right)^{2/3} \right)^{1/2} \\ &= \left(D - h^{2/3} D^{1/3} \right) \cdot \left(1 - \frac{h^{2/3}}{D^{2/3}} \right)^{1/2} \\ &= D \left(1 - \frac{h^{2/3}}{D^{2/3}} \right) \cdot \left(1 - \frac{h^{2/3}}{D^{2/3}} \right)^{1/2} = D \left(1 - \frac{h^{2/3}}{D^{2/3}} \right)^{3/2}. \end{aligned}$$

This means

$$\begin{aligned} \text{Maximum Usable Area} &= lx \\ &= lD \left(1 - \frac{h^{2/3}}{D^{2/3}} \right)^{3/2} \\ &= k \left(1 - \left(\frac{hl}{k} \right)^{2/3} \right)^{3/2} \end{aligned}$$

2. (a) The point on the line $y = mx$ corresponding to the point $(2, 3.5)$ has y -coordinate given by $y = m(2) = 2m$. Thus, for the point $(2, 3.5)$

$$\text{Vertical distance to the line} = |2m - 3.5|.$$

We calculate the distance similarly for the other two points. We want to minimize the sum, S , of the squares of these vertical distances

$$S = (2m - 3.5)^2 + (3m - 6.8)^2 + (5m - 9.1)^2.$$

Differentiating with respect to m gives

$$\frac{dS}{dm} = 2(2m - 3.5) \cdot 2 + 2(3m - 6.8) \cdot 3 + 2(5m - 9.1) \cdot 5.$$

Setting $dS/dm = 0$ gives

$$2 \cdot 2(2m - 3.5) + 2 \cdot 3(3m - 6.8) + 2 \cdot 5(5m - 9.1) = 0.$$

Canceling a 2 and multiplying out gives

$$\begin{aligned} 4m - 7 + 9m - 20.4 + 25m - 45.5 &= 0 \\ 38m &= 72.9 \\ m &= 1.92. \end{aligned}$$

Thus, the best fitting line has equation $y = 1.92x$.

- (b) To fit a line of the form $y = mx$ to the data, we take $y = V$ and $x = r^3$. Then k will be the slope m . So we make the following table of data:

r	2	5	7	8
$x = r^3$	8	125	343	512
$y = V$	8.7	140.3	355.8	539.2

To find the best fitting line of the form $y = mx$, we minimize the sums of the squares of the vertical distances from the line. For the point (8, 8.7) the corresponding point on the line has $y = 8m$, so

$$\text{Vertical distance} = |8m - 8.7|.$$

We find distances from the other points similarly. Thus we want to minimize

$$S = (8m - 8.7)^2 + (125m - 140.3)^2 + (343m - 355.8)^2 + (512m - 539.2)^2.$$

Differentiating with respect to m , which is the variable, and setting the derivative to zero:

$$\frac{dS}{dm} = 2(8m - 8.7) \cdot 8 + 2(125m - 140.3) \cdot 125 + 2(343m - 355.8) \cdot 343 + 2(512m - 539.2) \cdot 512 = 0.$$

After canceling a 2, solving for m leads to the equation

$$\begin{aligned} 8^2m + 125^2m + 343^2m + 512^2m &= 8 \cdot 8.7 + 125 \cdot 140.3 + 343 \cdot 355.8 + 512 \cdot 539.2 \\ m &= 1.051. \end{aligned}$$

Thus, $k = 1.051$ and the relationship between V and r is

$$V = 1.051r^3.$$

(In fact, the correct relationship is $V = \pi r^3/3$, so the exact value of k is $\pi/3 = 1.047$.)

- (c) The best fitting line minimizes the sum of the squares of the vertical distances from points to the line. Since the point on the line $y = mx$ corresponding to (x_1, y_1) is the point with $y = mx_1$; for this point we have

$$\text{Vertical distance} = |mx_1 - y_1|.$$

We calculate the distance from the other points similarly. Thus we want to minimize

$$S = (mx_1 - y_1)^2 + (mx_2 - y_2)^2 \cdots + (mx_n - y_n)^2.$$

The variable is m (the x_i s and y_i s are all constants), so

$$\begin{aligned}\frac{dS}{dm} &= 2(mx_1 - y_1)x_1 + 2(mx_2 - y_2)x_2 + \cdots + 2(mx_n - y_n)x_n = 0 \\ 2(m(x_1^2 + x_2^2 + \cdots + x_n^2) - (x_1y_1 + x_2y_2 + \cdots + x_ny_n)) &= 0.\end{aligned}$$

Solving for m gives

$$m = \frac{x_1y_1 + x_2y_2 + \cdots + x_ny_n}{x_1^2 + x_2^2 + \cdots + x_n^2} = \frac{\sum_{i=1}^n x_iy_i}{\sum_{i=1}^n x_i^2}.$$

3. The optimization problem in part (d) is unusual in that the optimum value is known (55 mph), and the problem is to find the conditions which lead to this optimum. A variant of this project is to ask what group of people in the real world might be interested in each of the questions asked. A possible answer is owners of trucking companies for parts (b) and (c), traffic police for part (d), and Interstate Commerce Commission for parts (e) and (f).

- (a) The total cost per mile is the cost of the driver plus the cost of fuel. We let

w be the driver's hourly wage in dollars/hour,
 v be the average speed in miles/hour,
 m be the weight of the truck in thousands of pounds,
 f the cost of fuel in dollars/gallon.

The cost per mile of the driver's wages is w/v . The cost of fuel per mile will be one over the "mileage per gallon" times the cost of fuel per gallon—i.e. f/mpg . The mileage per gallon is $6 - (m - 25)(0.02) - (v - 45)(0.1)$ for velocities over 45 and $6 - (m - 25)(0.02)$ for velocities under 45. So the total cost per mile, c , is

$$c = \begin{cases} \frac{w}{v} + \frac{f}{6 - (m - 25)(0.02)} & 0 < v \leq 45 \\ \frac{w}{v} + \frac{f}{6 - (m - 25)(0.02) - (v - 45)(0.1)} & 45 < v. \end{cases}$$

Note that there is an upper limit to the velocity in this last expression given when

$$6 - (m - 25)(0.02) - (v - 45)(0.1) = 0.$$

- (b) We are now given the values

$$\begin{aligned}w &= 15.00 \text{ dollars/hour} \\ m &= 75 \text{ thousand pounds} \\ f &= 1.25 \text{ dollars/gallon.}\end{aligned}$$

We have

$$c = \begin{cases} \frac{15}{v} + \frac{1.25}{6 - (75 - 25)(0.02)} & 0 < v \leq 45 \\ \frac{15}{v} + \frac{1}{6 - (75 - 25)(0.02) - (v - 45)(0.1)} & 45 < v, \end{cases}$$

which simplifies to

$$c = \begin{cases} \frac{15}{v} + \frac{1}{4} & 0 < v \leq 45 \\ \frac{15}{v} + \frac{1.25}{5 - (v - 45)(0.1)} & 45 < v < 95. \end{cases}$$

The upper limit for v occurs when $5 - (v - 45)(0.1) = 0$, that is, $v = 95$.

To initiate our search for a minimum, note that the function $c = 15/v + 1/4$ is strictly decreasing. So we only need find the minimum of the function

$$c = \frac{15}{v} + \frac{1.25}{5 - (v - 45)(0.1)}$$

on the interval $45 \leq v < 95$. Rearranging this slightly, we get

$$c = \frac{15}{v} + \frac{1.25}{9.5 - 0.1v}.$$

Then differentiating gives

$$\frac{dc}{dv} = -\frac{15}{v^2} + \frac{(1.25)(0.1)}{(9.5 - 0.1v)^2}.$$

Setting this to zero and solving, we get

$$\begin{aligned} 0 &= -\frac{15}{v^2} + \frac{(1.25)(0.1)}{(9.5 - 0.1v)^2} \\ 15(9.5 - 0.1v)^2 &= 0.125v^2 \\ 3.87(9.5 - 0.1v) &\approx \pm 0.354v \\ 36.8 - 0.387v &\approx \pm 0.354v \\ 36.8 &\approx 0.741v \text{ or } 36.8 \approx 0.033v \\ v &\approx 49.7 \text{ or } v \approx 1100. \end{aligned}$$

This last value is not in the domain, so we only consider the critical point $v = 49.7$ and the endpoints of $v = 45$ and $v = 95$. We evaluate the cost function:

$$\begin{aligned} c(45) &= 0.333 + 0.25 = 58.3\text{\$/mile} \\ c(49.7) &= 0.302 + 0.276 = 57.8\text{\$/mile} \\ c(95) &= \infty. \end{aligned}$$

So $v = 49.7$ is a minimum; the cheapest speed is 49.7 mph.

- (c) Evaluating the cost at $v = 55$ mph, $v = 60$ mph, and the minimum $v = 49.7$ mph gives

$$\begin{aligned} c(49.7) &= 57.8\text{\$} \\ c(55) &= 58.5\text{\$} \\ c(60) &= 60.7\text{\$}. \end{aligned}$$

Notice that the cost per mile does not rise very quickly. A produce hauler often gets extra revenue for getting there fast. Increasing speed from 50 to 60 mph decreases the transit time by over 15% but increases the costs by only 5%. Thus, many produce haulers will choose a speed above 49.7 mph.

- (d) Now we are not given the price of fuel, but we want the minimum to be at $v = 55$ mph. We find the value of f making $v = 55$ the minimum. The function we want to minimize is

$$c = \frac{15}{v} + \frac{f}{9.5 - 0.1v}.$$

Differentiating gives

$$\frac{dc}{dv} = -\frac{15}{v^2} + \frac{0.1f}{(9.5 - 0.1v)^2}$$

Setting this equal to 0, we have

$$\begin{aligned} 0 &= -\frac{15}{v^2} + \frac{0.1f}{(9.5 - 0.1v)^2} \\ 0 &= -15(9.5 - 0.1v)^2 + 0.1fv^2. \end{aligned}$$

Substituting $v = 55$ and solving for f gives

$$\begin{aligned} 0 &= -15(4)^2 + 0.1(55)^2 f \\ f &\approx 80\$/\text{gallon}. \end{aligned}$$

- (e) Now we are not told the driver's wages, w , or the fuel cost, f . We want to find the relationship between w and f making the minimum cost occur at $v = 55$ mph. We have

$$\begin{aligned} c &= \frac{w}{v} + \frac{f}{9.5 - 0.1v} \\ \frac{dc}{dv} &= -\frac{w}{v^2} + \frac{0.1f}{(9.5 - 0.1v)^2}. \end{aligned}$$

We need this to equal 0 when $v = 55$, so

$$0 = -\frac{w}{3025} + \frac{0.1f}{16}.$$

This means

$$\frac{w}{f} = \frac{(3025)(0.1)}{16} = 18.9,$$

that is, the fuel cost per gallon should be $1/18.9$ that of the driver's hourly wage. If the Interstate Commerce Commission wants truck drivers to keep to a speed of 55 mph, they should consider taxing fuel or driver's wages so that they remain in the relation $w = 18.9f$.

- (f) Now we assume $w = 18.9f$ and that m is variable. We want to minimize cost, getting a relationship between m and the optimal v . The function we want to minimize is

$$\begin{aligned} c &= \frac{18.9f}{v} + \frac{f}{6 - (m - 25)(0.02) - (v - 45)(0.1)} \\ &= \frac{18.9f}{v} + \frac{f}{11 - 0.02m - 0.1v}. \end{aligned}$$

Differentiating gives

$$\frac{dc}{dv} = \frac{-18.9f}{v^2} + \frac{0.1f}{(11 - 0.02m - 0.1v)^2}.$$

We are interested in when $dc/dv = 0$:

$$-\frac{18.9f}{v^2} + \frac{0.1f}{(11 - 0.02m - 0.1v)^2} = 0.$$

Solving gives

$$v = 63.7 - 0.116m \quad \text{or} \quad v = 403.5 - 0.734m.$$

Only the first gives plausible speeds (and gives $v = 55$ when $m = 75$), so we conclude the optimal speed varies linearly with weight according to the equation $v = 63.7 - 0.116m$. This means that every 10,000 increase in weight reduces the optimal speed by just over 1 mph.

4. (a) (i) We want to minimize A , the total area lost to the forest, which is made up of n firebreaks and 1 stand of trees lying between firebreaks. The area of each firebreak is $(50 \text{ km})(0.01 \text{ km}) = 0.5 \text{ km}^2$, so the total area lost to the firebreaks is $0.5n \text{ km}^2$. There are n total stands of trees between firebreaks. The area of a single stand of trees can be found by subtracting the firebreak area from the forest and dividing by n , so

$$\text{Area of one stand of trees} = \frac{2500 - 0.5n}{n}.$$

Thus, the total area lost is

$$\begin{aligned} A &= \text{Area of one stand} + \text{Area lost to firebreaks} \\ &= \frac{2500 - 0.5n}{n} + 0.5n = \frac{2500}{n} - 0.5 + 0.5n. \end{aligned}$$

We assume that A is a differentiable function of a continuous variable, n . Differentiating this function yields

$$\frac{dA}{dn} = -\frac{2500}{n^2} + 0.5.$$

At critical points, $dA/dn = 0$, so $0.5 = 2500/n^2$ or $n = \sqrt{2500/0.5} \approx 70.7$. Since n must be an integer, we check that when $n = 71$, $A = 70.211$ and when $n = 70$, $A = 70.214$. Thus, $n = 71$ gives a smaller area lost.

We can check that this is a local minimum since the second derivative is positive everywhere

$$\frac{d^2A}{dn^2} = \frac{5000}{n^3} > 0.$$

Finally, we check the endpoints: $n = 1$ yields the entire forest lost after a fire, since there is only one stand of trees in this case and it all burns. The largest n is 5000, and in this case the firebreaks remove the entire forest. Both of these cases maximize the area of forest lost. Thus, $n = 71$ is a global minimum. So 71 firebreaks minimizes the area of forest lost.

(ii) Repeating the calculation using b for the width gives

$$A = \frac{2500}{n} - 50b + 50bn,$$

and

$$\frac{dA}{dn} = \frac{-2500}{n^2} + 50b.$$

with a critical point when $b = 50/n^2$ so $n = \sqrt{50/b}$. So, for example, if we make the width b four times as large we need half as many firebreaks.

(b) We want to minimize A , the total area lost to the forest, which is made up of n firebreaks in one direction, n firebreaks in the other, and one square of trees surrounded by firebreaks. The area of each firebreak is 0.5 km^2 , and there are $2n$ of them, giving a total of $0.5 \cdot 2n$. But this is larger than the total area covered by the firebreaks, since it counts the small intersection squares, of size $(0.01)^2$, twice. Since there are n^2 intersections, we must subtract $(0.01)^2 n^2$ from the total area of the $2n$ firebreaks. Thus,

$$\text{Area covered by the firebreaks} = 0.5 \cdot 2n - (0.01)^2 n^2.$$

To this we must add the area of one square patch of trees lost in a fire. These are squares of side $(50 - 0.01n)/n = 50/n - 0.01$. Thus the total area lost is

$$A = n - 0.0001n^2 + (50/n - 0.01)^2$$

Treating n as a continuous variable and differentiating this function yields

$$\frac{dA}{dn} = 1 - 0.0002n + 2 \left(\frac{50}{n} - 0.01 \right) \left(\frac{-50}{n^2} \right).$$

Using a computer algebra system to find critical points we find that $dA/dn = 0$ when $n \approx 17$ and $n = 5000$. Thus $n = 17$ gives a minimum lost area, since the endpoints of $n = 1$ and $n = 5000$ both yield $A = 2500$ or the entire forest lost. So we use 17 firebreaks in each direction.