

CHAPTER FIVE

Solutions for Section 5.1

Exercises

1. (a) Suppose $f(t)$ is the flowrate in m^3/hr at time t . We are only given two values of the flowrate, so in making our estimates of the flow, we use one subinterval, with $\Delta t = 3/1 = 3$:

$$\text{Left estimate} = 3[f(6 \text{ am})] = 3 \cdot 100 = 300 \text{ m}^3 \quad (\text{an underestimate})$$

$$\text{Right estimate} = 3[f(9 \text{ am})] = 3 \cdot 280 = 840 \text{ m}^3 \quad (\text{an overestimate}).$$

The best estimate is the average of these two estimates,

$$\text{Best estimate} = \frac{\text{Left} + \text{Right}}{2} = \frac{300 + 840}{2} = 570 \text{ m}^3/\text{hr}.$$

- (b) Since the flowrate is increasing throughout, the error, i.e., the difference between over- and under-estimates, is given by

$$\text{Error} \leq \Delta t [f(9 \text{ am}) - f(6 \text{ am})] = \Delta t [280 - 100] = 180\Delta t.$$

We wish to choose Δt so that the error $180\Delta t \leq 6$, or $\Delta t \leq 6/180 = 1/30$. So the flowrate gauge should be read every $1/30$ of an hour, or every 2 minutes.

2. (a) Lower estimate = $(45)(2) + (16)(2) + (0)(2) = 122$ feet.
Upper estimate = $(88)(2) + (45)(2) + (16)(2) = 298$ feet.

(b)

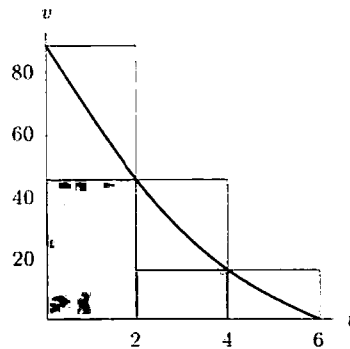

3. (a) Note that 15 minutes equals 0.25 hours. Lower estimate = $11(0.25) + 10(0.25) = 5.25$ miles. Upper estimate = $12(0.25) + 11(0.25) = 5.75$ miles.
(b) Lower estimate = $11(0.25) + 10(0.25) + 10(0.25) + 8(0.25) + 7(0.25) + 0(0.25) = 11.5$ miles. Upper estimate = $12(0.25) + 11(0.25) + 10(0.25) + 10(0.25) + 8(0.25) + 7(0.25) = 14.5$ miles.
(c) The difference between Roger's pace at the beginning and the end of his run is 12 mph. If the time between the measurements is h , then the difference between the upper and lower estimates is $12h$. We want $12h < 0.1$, so

$$h < \frac{0.1}{12} \approx 0.0083 \text{ hours} = 30 \text{ seconds}$$

Thus Jeff would have to measure Roger's pace every 30 seconds.

4. (a) An overestimate is 7 tons. An underestimate is 5 tons.
(b) An overestimate is $7 + 8 + 10 + 13 + 16 + 20 = 74$ tons. An underestimate is $5 + 7 + 8 + 10 + 13 + 16 = 59$ tons.
(c) If measurements are made every Δt months, then the error is $|f(6) - f(0)| \cdot \Delta t$. So for this to be less than 1 ton, we need $(20 - 5) \cdot \Delta t < 1$, or $\Delta t < 1/15$. So measurements every 2 days or so will guarantee an error in over- and underestimates of less than 1 ton.

Problems

5. (a) Car A has the largest maximum velocity because the peak of car A 's velocity curve is higher than the peak of B 's.
 (b) Car A stops first because the curve representing its velocity hits zero (on the t -axis) first.
 (c) Car B travels farther because the area under car B 's velocity curve is the larger.
6. (a) Since car B starts at $t = 2$, the tick marks on the horizontal axis (which we assume are equally spaced) are 2 hours apart. Thus car B stops at $t = 6$ and travels for 4 hours.
 Car A starts at $t = 0$ and stops at $t = 8$, so it travels for 8 hours.
 (b) Car A 's maximum velocity is approximately twice that of car B , that is 100 km/hr.
 (c) The distance traveled is given by the area of under the velocity graph. Using the formula for the area of a triangle, the distances are given approximately by

$$\text{Car } A \text{ travels} = \frac{1}{2} \cdot \text{Base} \cdot \text{Height} = \frac{1}{2} \cdot 8 \cdot 100 = 400 \text{ km}$$

$$\text{Car } B \text{ travels} = \frac{1}{2} \cdot \text{Base} \cdot \text{Height} = \frac{1}{2} \cdot 4 \cdot 50 = 100 \text{ km.}$$

7. To find the distance the car moved before stopping, we estimate the distance traveled for each two-second interval. Since speed decreases throughout, we know that the left-handed sum will be an overestimate to the distance traveled and the right-hand sum an underestimate. Applying the formulas for these sums with $\Delta t = 2$ gives:

$$\text{LEFT} = 2(100 + 80 + 50 + 25 + 10) = 530 \text{ ft.}$$

$$\text{RIGHT} = 2(80 + 50 + 25 + 10 + 0) = 330 \text{ ft.}$$

- (a) The best estimate of the distance traveled will be the average of these two estimates, or

$$\text{Best estimate} = \frac{530 + 330}{2} = 430 \text{ ft.}$$

- (b) All we can be sure of is that the distance traveled lies between the upper and lower estimates calculated above. In other words, all the black-box data tells us for sure is that the car traveled between 330 and 530 feet before stopping. So we can't be completely sure about whether it hit the skunk or not.

8. Using $\Delta t = 2$,

$$\begin{aligned} \text{Left-hand sum} &= v(0) \cdot 2 + v(2) \cdot 2 + v(4) \cdot 2 \\ &= 1(2) + 5(2) + 17(2) \\ &= 46 \end{aligned}$$

$$\begin{aligned} \text{Right-hand sum} &= v(2) \cdot 2 + v(4) \cdot 2 + v(6) \cdot 2 \\ &= 5(2) + 17(2) + 37(2) \\ &= 118 \end{aligned}$$

$$\text{Average} = \frac{46 + 118}{2} = 82$$

Distance traveled ≈ 82 meters.

9. Using $\Delta t = 0.2$, our upper estimate is

$$\frac{1}{1+0}(0.2) + \frac{1}{1+0.2}(0.2) + \frac{1}{1+0.4}(0.2) + \frac{1}{1+0.6}(0.2) + \frac{1}{1+0.8}(0.2) \approx 0.75.$$

The lower estimate is

$$\frac{1}{1+0.2}(0.2) + \frac{1}{1+0.4}(0.2) + \frac{1}{1+0.6}(0.2) + \frac{1}{1+0.8}(0.2) + \frac{1}{1+1}(0.2) \approx 0.65.$$

Since v is a decreasing function, the bug has crawled more than 0.65 meters, but less than 0.75 meters. We average the two to get a better estimate:

$$\frac{0.65 + 0.75}{2} = 0.70 \text{ meters.}$$

10. Using whole grid squares, we can overestimate the area as $3 + 3 + 3 + 3 + 2 + 1 = 15$, and we can underestimate the area as $1 + 2 + 2 + 1 + 0 + 0 = 6$.

11. Just counting the squares (each of which has area 10), and allowing for the broken squares, we can see that the area under the curve from 0 to 6 is between 140 and 150. Hence the distance traveled is between 140 and 150 meters.
12. We want the error to be less than 0.1, so take Δx such that $|f(1) - f(0)|\Delta x < 0.1$, giving

$$\Delta x < \frac{0.1}{|e^{-\frac{1}{2}} - 1|} \approx 0.25$$

so take $\Delta x = 0.25$ or $n = 4$. Then the left sum = 0.9016, and the right sum = 0.8033, so a reasonable estimate for the area is $(0.9016 + 0.8033)/2 = 0.8525$. Certainly 0.85 is within 0.1 of the actual answer.

13. (a) An upper estimate is $9.81 + 8.03 + 6.53 + 5.38 + 4.41 = 34.16$ m/sec. A lower estimate is $8.03 + 6.53 + 5.38 + 4.41 + 3.61 = 27.96$ m/sec.
- (b) The average is $\frac{1}{2}(34.16 + 27.96) = 31.06$ m/sec. Because the graph of acceleration is concave up, this estimate is too high, as can be seen in the figure to below. The area of the shaded region is the average of the areas of the rectangles $ABFE$ and $CDFE$.

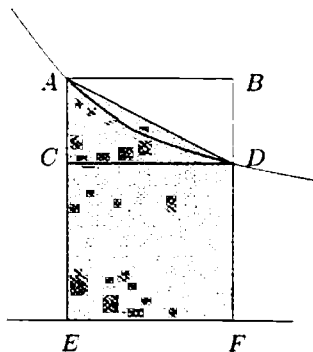

14. The car's speed increases by 60 mph in $1/2$ hour, that is at a rate of $60/(1/2) = 120$ mph per hour, or $120/60 = 2$ mph per minute. Thus every 5 minutes the speed has increased by 10 mph. At the start of the first 5 minutes, the speed was 10 mph and at the end, the speed was 20 mph. To find the distance traveled, use Distance = Speed \times Time. Since $5 \text{ min} = 5/60$ hour, the distance traveled during the first 5 minutes was between

$$10 \cdot \frac{5}{60} \text{ mile} \quad \text{and} \quad 20 \cdot \frac{5}{60} \text{ mile.}$$

Since the speed was between 10 and 20 mph during this five minute period, the fuel efficiency during this period is between 15 mpg and 18 mpg. So the fuel used during this period is between

$$\frac{1}{18} \cdot 10 \cdot \frac{5}{60} \text{ gallons} \quad \text{and} \quad \frac{1}{15} \cdot 20 \cdot \frac{5}{60} \text{ gallons.}$$

Thus, an underestimate of the fuel used is

$$\text{Fuel} = \left(\frac{1}{18} \cdot 10 + \frac{1}{21} \cdot 20 + \frac{1}{23} \cdot 30 + \frac{1}{24} \cdot 40 + \frac{1}{25} \cdot 50 + \frac{1}{26} \cdot 60 \right) \frac{5}{60} = 0.732 \text{ gallons.}$$

An overestimate of the fuel used is

$$\text{Fuel} = \left(\frac{1}{15} \cdot 20 + \frac{1}{18} \cdot 30 + \frac{1}{21} \cdot 40 + \frac{1}{23} \cdot 50 + \frac{1}{24} \cdot 60 + \frac{1}{25} \cdot 70 \right) \frac{5}{60} = 1.032 \text{ gallons.}$$

Solutions for Section 5.2

Exercises

1.

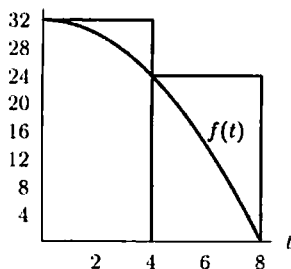
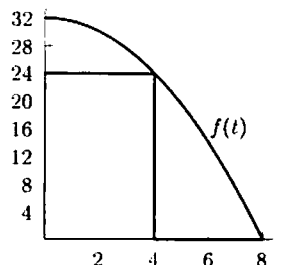
Figure 5.1: Left Sum, $\Delta t = 4$ Figure 5.2: Right Sum, $\Delta t = 4$

(a) Left-hand sum = $32(4) + 24(4) = 224$.

(b) Right-hand sum = $24(4) + 0(4) = 96$.

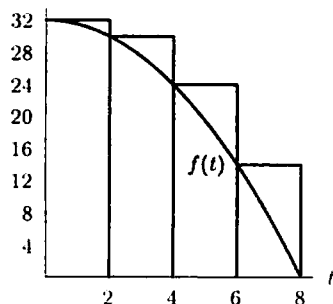
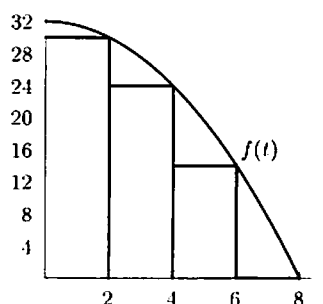
Figure 5.3: Left Sum, $\Delta t = 2$ Figure 5.4: Right Sum, $\Delta t = 2$

(c) Left-hand sum = $32(2) + 30(2) + 24(2) + 14(2) = 200$.

(d) Right-hand sum = $30(2) + 24(2) + 14(2) + 0(2) = 136$.

2. The graph given shows that f is positive for $0 \leq t \leq 1$. Since the graph is contained within a rectangle of height 100 and length 1, the answers -98.35 and 100.12 are both either too small or too large to represent $\int_0^1 f(t) dt$. Since the graph of f is above the horizontal line $y = 80$ for $0 \leq t \leq 0.95$, the best estimate is 93.47 and not 71.84 .

3. $\int_0^3 f(x) dx$ is equal to the area shaded. We estimate the area by counting shaded rectangles. There are 3 fully shaded and about 4 partially shaded rectangles, for a total of approximately 5 shaded rectangles. Since each rectangle represents 4 square units, our estimated area is $5(4) = 20$. We have

$$\int_0^3 f(x) dx \approx 20.$$

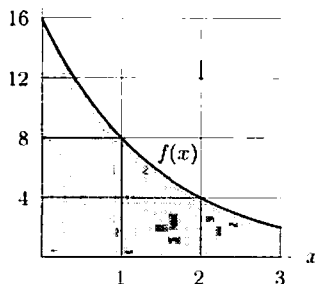

Figure 5.5

4. We know that

$$\int_{-10}^{15} f(x) dx = \text{Area under } f(x) \text{ between } x = -10 \text{ and } x = 15.$$

The area under the curve consists of approximately 14 boxes, and each box has area $(5)(5) = 25$. Thus, the area under the curve is about $(14)(25) = 350$, so

$$\int_{-10}^{15} f(x) dx \approx 350.$$

5. With $\Delta x = 5$, we have

$$\text{Left-hand sum} = 5(0 + 100 + 200 + 100 + 200 + 250 + 275) = 5625,$$

$$\text{Right-hand sum} = 5(100 + 200 + 100 + 200 + 250 + 275 + 300) = 7125.$$

The average of these two sums is our best guess for the value of the integral;

$$\int_{-15}^{20} f(x) dx \approx \frac{5625 + 7125}{2} = 6375.$$

6. We estimate $\int_0^{40} f(x) dx$ using left- and right-hand sums:

$$\text{Left sum} = (350)(10) + (410)(10) + (435)(10) + (450)(10) = 16,450.$$

$$\text{Right sum} = (410)(10) + (435)(10) + (450)(10) + (460)(10) = 17,550.$$

We estimate that

$$\int_0^{40} f(x) dx \approx \frac{16450 + 17550}{2} = 17,000.$$

In this estimate, we used $n = 4$ and $\Delta x = 10$.

7. With $\Delta x = 3$, we have

$$\text{Left-hand sum} = 3(32 + 22 + 15 + 11) = 240.$$

$$\text{Right-hand sum} = 3(22 + 15 + 11 + 9) = 171.$$

The average of these two sums is our best guess for the value of the integral;

$$\int_0^{12} f(x) dx \approx \frac{240 + 171}{2} = 205.5.$$

8. We take $\Delta x = 3$. Then:

$$\begin{aligned} \text{Left-hand sum} &= 50(3) + 48(3) + 44(3) + 36(3) + 24(3) \\ &= 606 \end{aligned}$$

$$\begin{aligned} \text{Right-hand sum} &= 48(3) + 44(3) + 36(3) + 24(3) + 8(3) \\ &= 480 \end{aligned}$$

$$\text{Average} = \frac{606 + 480}{2} = 543.$$

So,

$$\int_0^{15} f(x) dx \approx 543.$$

9. We use a calculator or computer to see that $\int_0^3 2^x dx = 10.0989$.

10. We use a calculator or computer to see that $\int_0^1 \sin(t^2) dt = 0.3103$.

11. We use a calculator or computer to see that $\int_{-1}^1 e^{-x^2} dx = 1.4936$.

12.

n	2	10	50	250
Left-hand Sum	0.0625	0.2025	0.2401	0.248004
Right-hand Sum	0.5625	0.3025	0.2601	0.252004

The sums seem to be converging to $\frac{1}{4}$. Since x^3 is monotone on $[0, 1]$, the true value is between 0.248004 and 0.252004.

13.

n	2	10	50	250
Left-hand Sum	1.34076	1.07648	1.01563	1.00314
Right-hand Sum	0.55536	0.91940	0.98421	0.99686

The sums seem to be converging to 1. Since $\cos x$ is monotone on $[0, \pi/2]$, the true value is between 1.00314 and .99686.

14.

n	2	10	50	250
Left-hand Sum	-0.394991	-0.0920539	-0.0429983	-0.0335556
Right-hand Sum	0.189470	0.0248382	-0.0196199	-0.0288799

There is no obvious guess as to what the limiting sum is. Moreover, since $\sin(t^2)$ is *not* monotonic on $[2, 3]$, we cannot be sure that the true value is between -0.0335556 and -0.0288799 .

15. A graph of $y = \ln x$ shows that this function is non-negative on the interval $x = 1$ to $x = 4$. Thus,

$$\text{Area} = \int_1^4 \ln x \, dx = 2.545.$$

The integral was evaluated on a calculator.

16. Since $\cos t \geq 0$ for $0 \leq t \leq \pi/2$, the area is given by

$$\text{Area} = \int_0^{\pi/2} \cos t \, dt = 1.$$

17. The graph of $y = 7 - x^2$ has intercepts $x = \pm\sqrt{7}$. See Figure 5.6. Therefore we have

$$\text{Area} = \int_{-\sqrt{7}}^{\sqrt{7}} (7 - x^2) \, dx = 24.7.$$

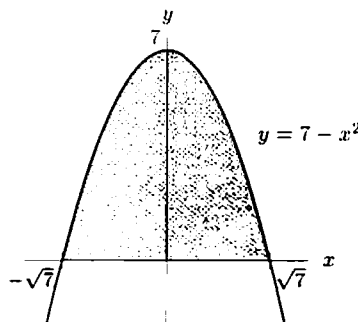

Figure 5.6

18. Since $\cos \sqrt{x} > 0$ for $0 \leq x \leq 2$, the area is given by

$$\text{Area} = \int_0^2 \cos \sqrt{x} \, dx = 1.1.$$

19. The graph of $y = e^x$ is above the line $y = 1$ for $0 \leq x \leq 2$. See Figure 5.7. Therefore

$$\text{Area} = \int_0^2 (e^x - 1) dx = 4.39.$$

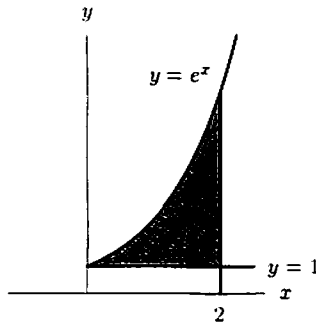

Figure 5.7

20. Since $x^3 \leq x^2$ for $0 \leq x \leq 1$, we have

$$\text{Area} = \int_0^1 (x^2 - x^3) dx = 0.0833.$$

21. Since $x^{1/2} \leq x^{1/3}$ for $0 \leq x \leq 1$, we have

$$\text{Area} = \int_0^1 (x^{1/3} - x^{1/2}) dx = 0.0833.$$

Problems

22. (a) See Figure 5.8.

$$\text{Left sum} = f(1)\Delta x + f(1.5)\Delta x = (\ln 1)0.5 + \ln(1.5)0.5 = (\ln 1.5)0.5.$$

(b) See Figure 5.9.

$$\text{Right sum} = f(1.5)\Delta x + f(2)\Delta x = (\ln 1.5)0.5 + (\ln 2)0.5.$$

(c) Right sum is an overestimate, left sum is an underestimate.

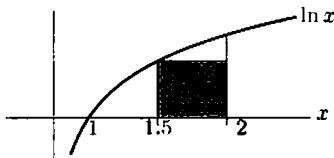

Figure 5.8: Left sum

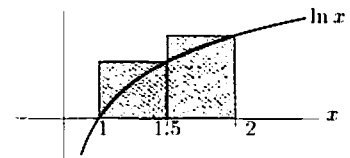
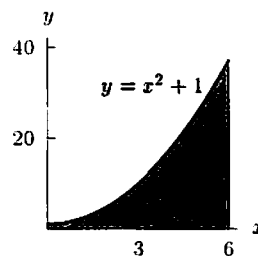

Figure 5.9: Right sum

23. (a) $\int_0^6 (x^2 + 1) dx = 78$



(b) Using $n = 3$, we have

$$\begin{aligned}\text{Left-hand sum} &= f(0) \cdot 2 + f(2) \cdot 2 + f(4) \cdot 2 \\ &= 1(2) + 5(2) + 17(2) = 46.\end{aligned}$$

This sum is an underestimate. See Figure 5.10.

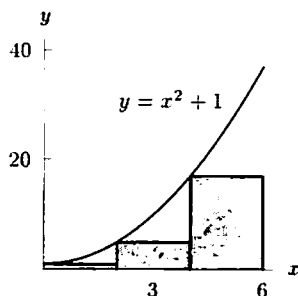

Figure 5.10

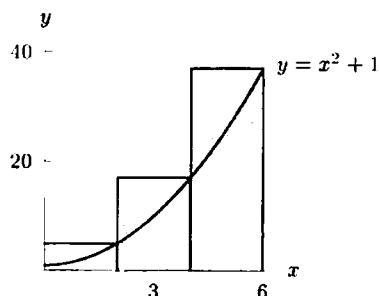

Figure 5.11

(c)

$$\begin{aligned}\text{Right-hand sum} &= f(2) \cdot 2 + f(4) \cdot 2 + f(6) \cdot 2 \\ &= 5(2) + 17(2) + 37(2) \\ &= 118.\end{aligned}$$

This sum is an overestimate. See Figure 5.11.

24. Left-hand sum gives: $1^2(1/4) + (1.25)^2(1/4) + (1.5)^2(1/4) + (1.75)^2(1/4) = 1.96875$.

Right-hand sum gives: $(1.25)^2(1/4) + (1.5)^2(1/4) + (1.75)^2(1/4) + (2)^2(1/4) = 2.71875$.

We estimate the value of the integral by taking the average of these two sums, which is 2.34375. Since x^2 is monotonic on $1 \leq x \leq 2$, the true value of the integral lies between 1.96875 and 2.71875. Thus the most our estimate could be off is 0.375. We expect it to be much closer. (And it is—the true value of the integral is $7/3 \approx 2.333$.)

25. The areas we computed are shaded in Figure 5.12. Since $y = x^2$ and $y = x^{1/2}$ are inverse functions, their graphs are reflections about the line $y = x$. Similarly, $y = x^3$ and $y = x^{1/3}$ are inverse functions and their graphs are reflections about the line $y = x$. Therefore, the two shaded areas in Figure 5.12 are equal.

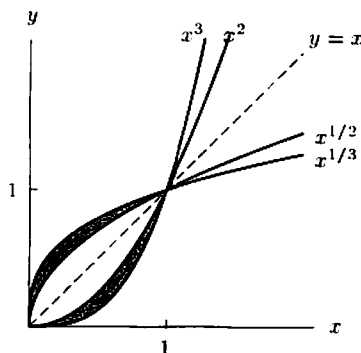
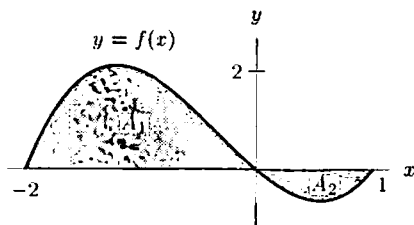

Figure 5.12

26. (a)



$$(b) A_1 = \int_{-2}^0 f(x) dx = 2.667.$$

$$A_2 = - \int_0^1 f(x) dx = 0.417.$$

So total area = $A_1 + A_2 \approx 3.084$. Note that while A_1 and A_2 are accurate to 3 decimal places, the quoted value for $A_1 + A_2$ is accurate only to 2 decimal places.

$$(c) \int_{-2}^1 f(x) dx = A_1 - A_2 = 2.250.$$

$$27. \int_0^4 \cos \sqrt{x} dx = 0.80 = \text{Area } A_1 - \text{Area } A_2$$

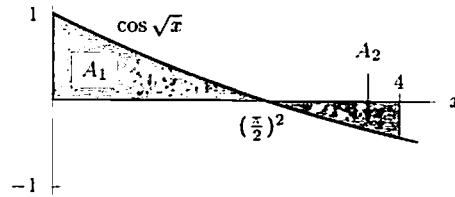

28.

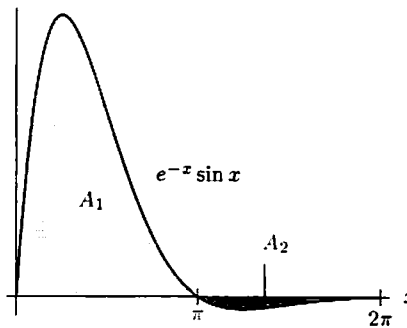

Figure 5.13

Looking at the graph of $e^{-x} \sin x$ for $0 \leq x \leq 2\pi$ in Figure 5.13, we see that the area, A_1 , below the curve for $0 \leq x \leq \pi$ is much greater than the area, A_2 , above the curve for $\pi \leq x \leq 2\pi$. Thus, the integral is

$$\int_0^{2\pi} e^{-x} \sin x dx = A_1 - A_2 > 0.$$

29. We have $\Delta x = 2/500 = 1/250$. The formulas for the left- and right-hand Riemann sums give us that

$$\text{Left} = \Delta x [f(-1) + f(-1 + \Delta x) + \dots + f(1 - 2\Delta x) + f(1 - \Delta x)]$$

$$\text{Right} = \Delta x [f(-1 + \Delta x) + f(-1 + 2\Delta x) + \dots + f(1 - \Delta x) + f(1)].$$

Subtracting these yields

$$\text{Right} - \text{Left} = \Delta x [f(1) - f(-1)] = \frac{1}{250} [6 - 2] = \frac{4}{250} = \frac{2}{125}.$$

30. (a) The area between the graph of f and the x -axis between $x = a$ and $x = b$ is 13, so

$$\int_a^b f(x) dx = 13.$$

(b) Since the graph of $f(x)$ is below the x -axis for $b < x < c$,

$$\int_b^c f(x) dx = -2.$$

(c) Since the graph of $f(x)$ is above the x -axis for $a < x < b$ and below for $b < x < c$,

$$\int_a^c f(x) dx = 13 - 2 = 11.$$

(d) The graph of $|f(x)|$ is the same as the graph of $f(x)$ except that the part below the x -axis is reflected to be above it. See Figure 5.14. Thus

$$\int_a^c |f(x)| dx = 13 + 2 = 15.$$

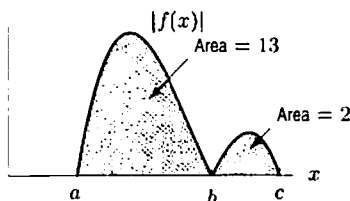

Figure 5.14

31. The region shaded between $x = 0$ and $x = 2$ appears to have approximately the same area as the region shaded between $x = -2$ and $x = 0$, but it lies below the axis. Since $\int_{-2}^0 f(x) dx = 4$, we have the following results:

(a) $\int_0^2 f(x) dx \approx -\int_{-2}^0 f(x) dx = -4.$

(b) $\int_{-2}^2 f(x) dx \approx 4 - 4 = 0.$

(c) The total area shaded is approximately $4 + 4 = 8.$

32. (a) $\int_{-3}^0 f(x) dx = -2.$

(b) $\int_{-3}^4 f(x) dx = \int_{-3}^0 f(x) dx + \int_0^3 f(x) dx + \int_3^4 f(x) dx = -2 + 2 - \frac{4}{2} = -\frac{4}{2}.$

33. We have

$$\Delta x = \frac{4}{3} = \frac{b-a}{n} \quad \text{and} \quad n = 3, \quad \text{so} \quad b-a = 4 \quad \text{or} \quad b = a+4.$$

The function, $f(x)$, is squaring something. Since it is a left-hand sum, $f(x)$ could equal x^2 with $a = 2$ and $b = 6$ (note that $2 + 3(\frac{4}{3})$ gives the right-hand endpoint of the last interval). Or, $f(x)$ could possibly equal $(x+2)^2$ with $a = 0$ and $b = 4$. Other answers are possible.

34. (a) If the interval $1 \leq t \leq 2$ is divided into n equal subintervals of length $\Delta t = 1/n$, the subintervals are given by

$$1 \leq t \leq 1 + \frac{1}{n}, \quad 1 + \frac{1}{n} \leq t \leq 1 + \frac{2}{n}, \quad \dots, \quad 1 + \frac{n-1}{n} \leq t \leq 2.$$

The left-hand sum is given by

$$\text{Left sum} = \sum_{r=0}^{n-1} f\left(1 + \frac{r}{n}\right) \frac{1}{n} = \sum_{r=0}^{n-1} \frac{1}{1+r/n} \cdot \frac{1}{n} = \sum_{r=0}^{n-1} \frac{1}{n+r}$$

and the right-hand sum is given by

$$\text{Right sum} = \sum_{r=1}^n f\left(1 + \frac{r}{n}\right) \frac{1}{n} = \sum_{r=1}^n \frac{1}{n+r}.$$

Since $f(t) = 1/t$ is decreasing in the interval $1 \leq t \leq 2$, we know that the right-hand sum is less than $\int_1^2 1/t \, dt$ and the left-hand sum is larger than this integral. Thus we have

$$\sum_{r=1}^n \frac{1}{n+r} < \int_1^2 \frac{1}{t} \, dt < \sum_{r=0}^{n-1} \frac{1}{n+r}.$$

(b) Subtracting the sums gives

$$\sum_{r=0}^{n-1} \frac{1}{n+r} - \sum_{r=1}^n \frac{1}{n+r} = \frac{1}{n} - \frac{1}{2n} = \frac{1}{2n}.$$

(c) Here we need to find n such that

$$\frac{1}{2n} \leq 5 \times 10^{-6}, \quad \text{so} \quad n \geq \frac{1}{10} \times 10^6 = 10^5.$$

35. The statement is rarely true. The graph of almost any non-linear monotonic function, such as x^{10} for $0 < x < 1$, should provide convincing geometric evidence. Furthermore, if the statement were true, then $(\text{LHS} + \text{RHS})/2$ would always give the exact value of the definite integral. This is not true.

36. As illustrated in Figure 5.15, the left- and right-hand sums are both equal to $(4\pi) \cdot 3 = 12\pi$, while the integral is smaller. Thus we have:

$$\int_0^{4\pi} (2 + \cos x) \, dx < \text{Left-hand sum} = \text{Right-hand sum}.$$

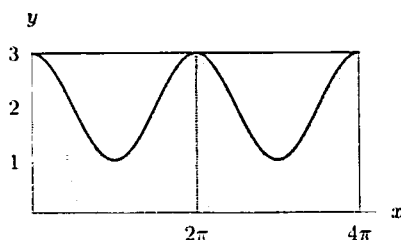

Figure 5.15: Integral vs. Left- and Right-Hand Sums

37.

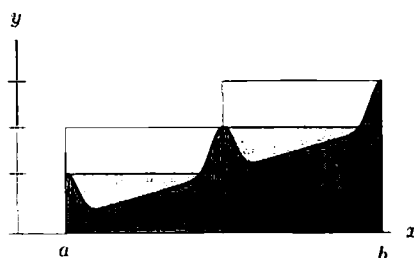

Figure 5.16: Integral vs. Left- and Right-Hand Sums

Solutions for Section 5.3

Exercises

1. Average value = $\frac{1}{2-0} \int_0^2 (1+t) \, dt = \frac{1}{2}(4) = 2.$

2. Average value = $\frac{1}{10-0} \int_0^{10} e^t \, dt = \frac{1}{10}(22025) = 2202.5$

3. Sketch the graph of f on $1 \leq x \leq 3$. The integral is the area under the curve, which is a trapezoidal area. So the average value is

$$\frac{1}{3-1} \int_1^3 (4x+7) dx = \frac{1}{2} \cdot \frac{11+19}{2} \cdot 2 = \frac{30}{2} = 15.$$

4. The units of measurement are meters per second (which are units of velocity).
 5. The units of measurement are dollars.
 6. The units of measurement are foot-pounds (which are units of work).
 7. (a) One small box on the graph corresponds to moving at 750 ft/min for 15 seconds, which corresponds to a distance of 187.5 ft. Estimating the area beneath the velocity curves, we find:
 Distance traveled by car 1 ≈ 5.5 boxes = 1031.25 ft.
 Distance traveled by car 2 ≈ 3 boxes = 562.5 ft.
 (b) The two cars will have gone the same distance when the areas beneath their velocity curves are equal. Since the two areas overlap, they are equal when the two shaded regions have equal areas, at $t \approx 1.6$ minutes. See Figure 5.17.

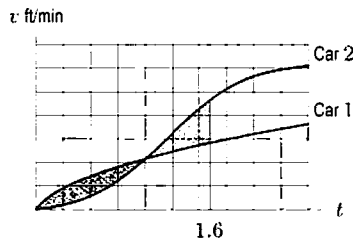

Figure 5.17

8. (a) At 3 pm, the car is traveling with a velocity of about 67 mph, while the truck has a velocity of 50 mph. Because the car is ahead of the truck at 3 pm and is traveling at a greater velocity, the distance between the car and the truck is increasing at this time. If d_{car} and d_{truck} represent the distance traveled by the car and the truck respectively, then

$$\text{distance apart} = d_{\text{car}} - d_{\text{truck}}.$$

The rate of change of the distance apart is given by its derivative:

$$\begin{aligned} (\text{distance apart})' &= (d_{\text{car}})' - (d_{\text{truck}})' \\ &= v_{\text{car}} - v_{\text{truck}} \end{aligned}$$

At 3 pm, we get $(\text{distance apart})' = 67 \text{ mph} - 50 \text{ mph} = 17 \text{ mph}$. Thus, at 3 pm the car is traveling with a velocity 17 mph greater than the truck's velocity, and the distance between them is increasing at 17 miles per hour.

- (b) At 2 pm, the car's velocity is greatest. Because the truck's velocity is constant, $v_{\text{car}} - v_{\text{truck}}$ will be largest when the car's velocity is largest. Thus, at 2 pm the distance between the car and the truck is increasing fastest—i.e., the car is pulling away at the greatest rate.

(Note: This only takes into account the time when the truck is moving. When the truck isn't moving from 12:00 to 1:00 the car pulls away from the truck at an even greater rate.)

9. (a)

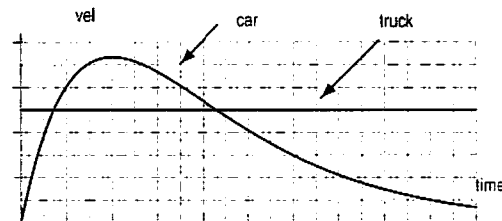

- (b) The graphs intersect twice, at about 0.7 hours and 4.3 hours. At each intersection point, the velocity of the car is equal to the velocity of the truck, so $v_{\text{car}} = v_{\text{truck}}$. From the time they start until 0.7 hours later, the truck is traveling at a greater velocity than the car, so the truck is ahead of the car and is pulling farther away. At 0.7 hours they are traveling at the same velocity, and after 0.7 hours the car is traveling faster than the truck, so that the car begins to gain on the truck. Thus, at 0.7 hours the truck is farther from the car than it is immediately before or after 0.7 hours.

Similarly, because the car's velocity is greater than the truck's after 0.7 hours, it will catch up with the truck and eventually pass and pull away from the truck until 4.3 hours, at which point the two are again traveling at the same velocity. After 4.3 hours the truck travels faster than the car, so that it now gains on the car. Thus, 4.3 hours represents the point where the car is farthest ahead of the truck.

10. For any t , consider the interval $[t, t + \Delta t]$. During this interval, oil is leaking out at an approximately constant rate of $f(t)$ gallons/minute. Thus, the amount of oil which has leaked out during this interval can be expressed as

$$\text{Amount of oil leaked} = \text{Rate} \times \text{Time} = f(t) \Delta t$$

and the units of $f(t) \Delta t$ are gallons/minute \times minutes = gallons. The total amount of oil leaked is obtained by adding all these amounts between $t = 0$ and $t = 60$. (An hour is 60 minutes.) The sum of all these infinitesimal amounts is the integral

$$\text{Total amount of oil leaked, in gallons} = \int_0^{60} f(t) dt.$$

Problems

11. (a) The amount leaked between $t = 0$ and $t = 2$ is $\int_0^2 R(t) dt$.

(b)

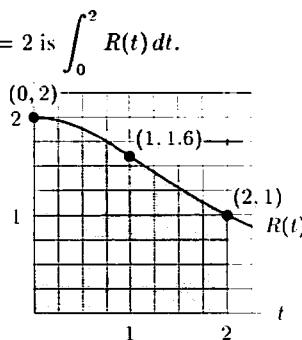

- (c) The rectangular boxes on the diagram each have area $\frac{1}{16}$. Of these 45 are wholly beneath the curve, hence the area under the curve is certainly more than $\frac{45}{16} > 2.81$. There are 9 more partially beneath the curve, and so the desired area is completely covered by 54 boxes. Therefore the area is less than $\frac{54}{16} < 3.38$.

These are very safe estimates but far apart. We can do much better by estimating what fractions of the broken boxes are beneath the curve. Using this method, we can estimate the area to be about 3.2, which corresponds to 3.2 gallons leaking over two hours.

12. The integral represents the area below the graph of $f(x)$ but above the x -axis.
 (a) Since each square has area 1, by counting squares and half-squares we find

$$\int_1^6 f(x) dx = 8.5.$$

- (b) The average value is $\frac{1}{6-1} \int_1^6 f(x) dx = \frac{8.5}{5} = \frac{17}{10} = 1.7$.

13. (a) The integral is the area above the x -axis minus the area below the x -axis. Thus, we can see that $\int_{-3}^3 f(x) dx$ is about $-6 + 2 = -4$ (the negative of the area from $t = -3$ to $t = 1$ plus the area from $t = 1$ to $t = 3$.)
 (b) Since the integral in part (a) is negative, the average value of $f(x)$ between $x = -3$ and $x = 3$ is negative. From the graph, however, it appears that the average value of $f(x)$ from $x = 0$ to $x = 3$ is positive. Hence (ii) is the larger quantity.
14. (a) The integral $\int_0^{50} f(t) dt$ represents the total emissions of nitrogen oxides, in millions of metric tons, during the period 1940 to 1990.
 (b) We estimate the integral using left- and right-hand sums:

$$\text{Left sum} = (6.9)(10) + (9.4)(10) + (13.0)(10) + (18.5)(10) + (20.9)(10) = 687.$$

$$\text{Right sum} = (9.4)(10) + (13.0)(10) + (18.5)(10) + (20.9)(10) + (19.6)(10) = 814.$$

We average the left- and right-hand sums to find the best estimate of the integral:

$$\int_0^{50} f(t)dt \approx \frac{687 + 814}{2} = 750.5 \text{ million metric tons.}$$

Between 1940 and 1990, about 750.5 million metric tons of nitrogen oxides were emitted.

15. Since W is in tons per week and t is in weeks since January 1, 2000, the integral $\int_0^{52} W dt$ gives the amount of waste, in tons, produced during the year 2000.

$$\text{Total waste during the year} = \int_0^{52} 3.75e^{-0.008t} dt = 159.5249 \text{ tons.}$$

Since waste removal costs \$15/ton, the cost of waste removal for the company is $159.5249 \cdot 15 = \$2392.87$.

16. The total number of “worker-hours” is equal to the area under the curve. The total area is about 14.5 boxes. Since each box represents (10 workers)(8 hours) = 80 worker-hours, the total area is 1160 worker-hours. At \$10 per hour, the total cost is \$11,600.
17. The time period 9am to 5pm is represented by the time $t = 0$ to $t = 8$ and $t = 24$ to $t = 32$. The area under the curve, or total number of worker-hours for these times, is about 9 boxes or $9(80) = 720$ worker-hours. The total cost for 9am to 5pm is $(720)(10) = \$7200$. The area under the rest of the curve is about 5.5 boxes, or $5.5(80) = 440$ worker-hours. The total cost for this time period is $(440)(15) = \$6600$. The total cost is about $7200 + 6600 = \$13,800$.
18. The area under the curve represents the number of cubic feet of storage times the number of days the storage was used. This area is given by

$$\begin{aligned} \text{Area under graph} &= \text{Area of rectangle} + \text{Area of triangle} \\ &= 30 \cdot 10,000 + \frac{1}{2} \cdot 30(30,000 - 10,000) \\ &= 600,000. \end{aligned}$$

Since the warehouse charges \$5 for every 10 cubic feet of storage used for a day, the company will have to pay $(5)(60,000) = \$300,000$.

19. (a) Since $f(x) = \sin x$ over $[0, \pi]$ is between 0 and 1, the average of $f(x)$ must itself be between 0 and 1. Furthermore, since the graph of $f(x)$ is concave down on this interval, the average value must be greater than the average height of the triangle shown in the figure, namely, 0.5.

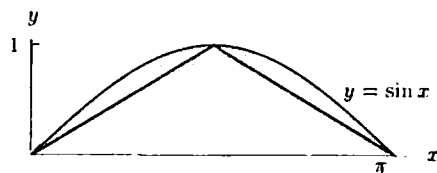

(b) Average = $\frac{1}{\pi - 0} \int_0^{\pi} \sin x dx = 0.64$.

20. (a) Average value = $\int_0^1 \sqrt{1-x^2} dx = 0.79$.

- (b) The area between the graph of $y = 1 - x$ and the x -axis is 0.5. Because the graph of $y = \sqrt{1-x^2}$ is concave down, it lies above the line $y = 1 - x$, so its average value is above 0.5. See figure below.

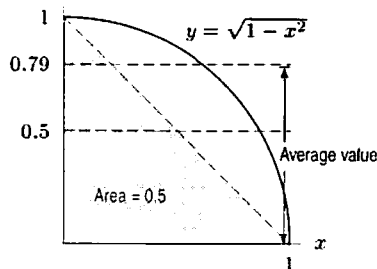

21. Since the average value is given by

$$\text{Average value} = \frac{1}{b-a} \int_a^b f(x) dx,$$

the units for dx inside the integral are canceled by the units for $1/(b-a)$ outside the integral, leaving only the units for $f(x)$. This is as it should be, since the average value of f should be measured in the same units as $f(x)$.

22. (a) At the end of one hour $t = 60$, and $H = 22^\circ\text{C}$.
 (b)

$$\begin{aligned} \text{Average temperature} &= \frac{1}{60} \int_0^{60} (20 + 980e^{-0.1t}) dt \\ &= \frac{1}{60} (10976) = 183^\circ\text{C}. \end{aligned}$$

- (c) Average temperature at beginning and end of hour $= (1000 + 22)/2 = 511^\circ\text{C}$. The average found in part (b) is smaller than the average of these two temperatures because the bar cools quickly at first and so spends less time at high temperatures. Alternatively, the graph of H against t is concave up.

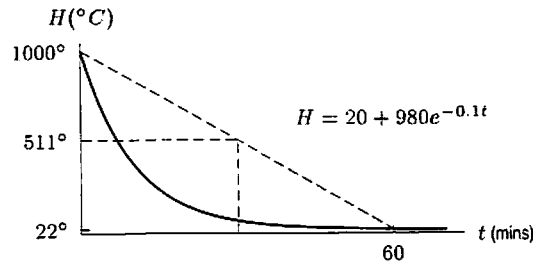

23. Since $t = 0$ in 1965 and $t = 35$ in 2000, we want:

$$\begin{aligned} \text{Average Value} &= \frac{1}{35-0} \int_0^{35} 225(1.15)^t dt \\ &= \frac{1}{35} (212,787) = \$6080. \end{aligned}$$

24. (a) Since $t = 0$ to $t = 31$ covers January:

$$\left(\begin{array}{l} \text{Average number of} \\ \text{daylight hours in January} \end{array} \right) = \frac{1}{31} \int_0^{31} [12 + 2.4 \sin(0.0172(t - 80))] dt.$$

Using left and right sums with $n = 100$ gives

$$\text{Average} \approx \frac{306}{31} \approx 9.9 \text{ hours.}$$

- (b) Assuming it is not a leap year, the last day of May is $t = 151 (= 31 + 28 + 31 + 30 + 31)$ and the last day of June is $t = 181 (= 151 + 30)$. Again finding the integral numerically:

$$\begin{aligned} \left(\begin{array}{l} \text{Average number of} \\ \text{daylight hours in June} \end{array} \right) &= \frac{1}{30} \int_{151}^{181} [12 + 2.4 \sin(0.0172(t - 80))] dt \\ &\approx \frac{431}{30} \approx 14.4 \text{ hours.} \end{aligned}$$

(c)

$$\begin{aligned} \left(\begin{array}{l} \text{Average for whole year} \end{array} \right) &= \frac{1}{365} \int_0^{365} [12 + 2.4 \sin(0.0172(t - 80))] dt \\ &\approx \frac{4381}{365} \approx 12.0 \text{ hours.} \end{aligned}$$

- (d) The average over the whole year should be 12 hours, as computed in (c). Since Madrid is in the northern hemisphere, the average for a winter month, such as January, should be less than 12 hours (it is 9.9 hours) and the average for a summer month, such as June, should be more than 12 hours (it is 14.4 hours).

25. Change in income $= \int_0^{12} r(t) dt = \int_0^{12} 40(1.002)^t dt = \485.80
26. Notice that the area of a square on the graph represents $\frac{10}{6}$ miles. At $t = 1/3$ hours, $v = 0$. The area between the curve v and the t -axis over the interval $0 \leq t \leq 1/3$ is $-\int_0^{1/3} v dt \approx \frac{5}{3}$. Since v is negative here, she is moving toward the lake. At $t = \frac{1}{3}$, she is about $5 - \frac{5}{3} = \frac{10}{3}$ miles from the lake. Then, as she moves away from the lake, v is positive for $\frac{1}{3} \leq t \leq 1$. At $t = 1$,

$$\int_0^1 v dt = \int_0^{1/3} v dt + \int_{1/3}^1 v dt \approx -\frac{5}{3} + 8 \cdot \frac{10}{6} = \frac{35}{3},$$

and the cyclist is about $5 + \frac{35}{3} = \frac{50}{3} = 16\frac{2}{3}$ miles from the lake. Since, starting from the moment $t = \frac{1}{3}$, she moves away from the lake, the cyclist will be farthest from the lake at $t = 1$. The maximal distance equals $16\frac{2}{3}$ miles.

27. (a) Over the interval $[-1, 3]$, we estimate that the total change of the population is about 1.5, by counting boxes between the curve and the x -axis; we count about 1.5 boxes below the x -axis from $x = -1$ to $x = 1$ and about 3 above from $x = 1$ to $x = 3$. So the average rate of change is just the total change divided by the length of the interval, that is $1.5/4 = 0.375$ thousand/hour.
- (b) We can estimate the total change of the algae population by counting boxes between the curve and the x -axis. Here, there is about 1 box above the x -axis from $x = -3$ to $x = -2$, about 0.75 of a box below the x -axis from $x = -2$ to $x = -1$, and a total change of about 1.5 boxes thereafter (as discussed in part (a)). So the total change is about $1 - 0.75 + 1.5 = 1.75$ thousands of algae.
28. (a) The black curve is for boys, the colored one for girls. The area under each curve represents the change in growth in centimeters. Since men are generally taller than women, the curve with the larger area under it is the height velocity of the boys.
- (b) Each square below the height velocity curve has area $1 \text{ cm/yr} \cdot 1 \text{ yr} = 1 \text{ cm}$. Counting squares lying below the black curve gives about 43 cm. Thus, on average, boys grow about 43 cm between ages 3 and 10.
- (c) Counting squares lying below the black curve gives about 23 cm growth for boys during their growth spurt. Counting squares lying below the colored curve gives about 18 cm for girls during their growth spurt.
- (d) We can measure the difference in growth by counting squares that lie between the two curves. Between ages 2 and 12.5, the average girl grows faster than the average boy. Counting squares yields about 5 cm between the colored and black curves for $2 \leq x \leq 12.5$. Counting squares between the curves for $12.5 \leq x \leq 18$ gives about 18 squares. Thus, there is a net increase of boys over girls by about $18 - 5 = 13 \text{ cm}$.
29. We know that the the integral of F , and therefore the work, can be obtained by computing the areas in Figure 5.18.

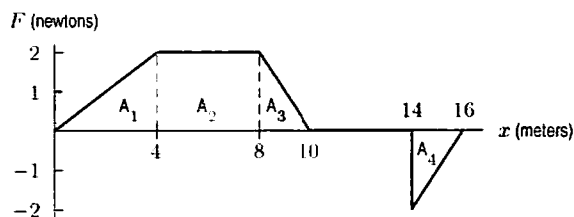

Figure 5.18

$$\begin{aligned} W &= \int_0^{16} F(x) dx = \text{Area above } x\text{-axis} - \text{Area below } x\text{-axis} \\ &= A_1 + A_2 + A_3 - A_4 \\ &= \frac{1}{2} \cdot 4 \cdot 2 + 4 \cdot 2 + \frac{1}{2} \cdot 2 \cdot 2 - \frac{1}{2} \cdot 2 \cdot 2 \\ &= 12 \text{ newton} \cdot \text{meters}. \end{aligned}$$

30. (a) Average value of $f = \frac{1}{\pi} \int_0^5 f(x) dx$.
- (b) Average value of $|f| = \frac{1}{5} \int_0^5 |f(x)| dx = \frac{1}{5} (\int_0^2 f(x) dx - \int_2^5 f(x) dx)$.

31. We'll show that in terms of the average value of f ,

$$I > II = IV > III$$

Using Problem 24 (a) on page 301,

$$\begin{aligned} \text{Average value of } f \text{ on II} &= \frac{\int_0^2 f(x) dx}{2} = \frac{\frac{1}{2} \int_{-2}^2 f(x) dx}{2} \\ &= \frac{\int_{-2}^2 f(x) dx}{4} \\ &= \text{Average value of } f \text{ on IV.} \end{aligned}$$

Since f is decreasing on $[0, 5]$, the average value of f on the interval $[0, c]$, where $0 \leq c \leq 5$, is decreasing as a function of c . The larger the interval the more low values of f are included. Hence

$$\text{Average value of } f \text{ on } [0, 1] > \text{Average value of } f \text{ on } [0, 2] > \text{Average value of } f \text{ on } [0, 5]$$

32. The graph of her velocity against time is a straight line from 0 mph to 60 mph; see Figure 5.19. Since the distance traveled is the area under the curve, we have

$$\text{Shaded area} = \frac{1}{2} \cdot t \cdot 60 = 10 \text{ miles}$$

Solving for t gives

$$t = \frac{1}{3} \text{ hr} = 20 \text{ minutes.}$$

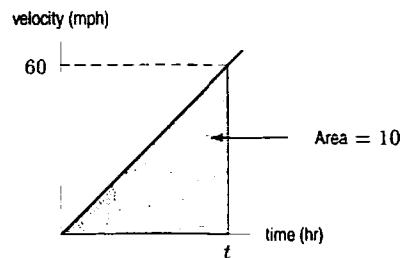

Figure 5.19

Solutions for Section 5.4

Exercises

1. We find the changes in $f(x)$ between any two values of x by counting the area between the curve of $f'(x)$ and the x -axis. Since $f'(x)$ is linear throughout, this is quite easy to do. From $x = 0$ to $x = 1$, we see that $f'(x)$ outlines a triangle of area $1/2$ below the x -axis (the base is 1 and the height is 1). By the Fundamental Theorem,

$$\int_0^1 f'(x) dx = f(1) - f(0),$$

so

$$\begin{aligned} f(0) + \int_0^1 f'(x) dx &= f(1) \\ f(1) &= 2 - \frac{1}{2} = \frac{3}{2} \end{aligned}$$

Similarly, between $x = 1$ and $x = 3$ we can see that $f'(x)$ outlines a rectangle below the x -axis with area -1 , so $f(2) = 3/2 - 1 = 1/2$. Continuing with this procedure (note that at $x = 4$, $f'(x)$ becomes positive), we get the table below.

x	0	1	2	3	4	5	6
$f(x)$	2	3/2	1/2	-1/2	-1	-1/2	1/2

2. Since $F(0) = 0$, $F(b) = \int_0^b f(t) dt$. For each b we determine $F(b)$ graphically as follows:

$$F(0) = 0$$

$$F(1) = F(0) + \text{Area of } 1 \times 1 \text{ rectangle} = 0 + 1 = 1$$

$$F(2) = F(1) + \text{Area of triangle } (\frac{1}{2} \cdot 1 \cdot 1) = 1 + 0.5 = 1.5$$

$$F(3) = F(2) + \text{Negative of area of triangle} = 1.5 - 0.5 = 1$$

$$F(4) = F(3) + \text{Negative of area of rectangle} = 1 - 1 = 0$$

$$F(5) = F(4) + \text{Negative of area of rectangle} = 0 - 1 = -1$$

$$F(6) = F(5) + \text{Negative of area of triangle} = -1 - 0.5 = -1.5$$

The graph of $F(t)$, for $0 \leq t \leq 6$, is shown in Figure 5.20.

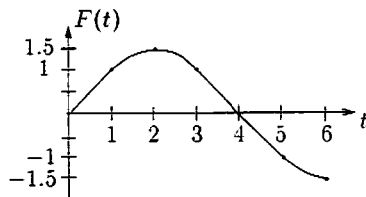

Figure 5.20

3. (a) A graph of $f'(x) = \sin(x^2)$ is shown in Figure 5.21. Since the derivative $f'(x)$ is positive between $x = 0$ and $x = 1$, the change in $f(x)$ is positive, so $f(1)$ is larger than $f(0)$. Between $x = 2$ and $x = 2.5$, we see that $f'(x)$ is negative, so the change in $f(x)$ is negative; thus, $f(2)$ is greater than $f(2.5)$.

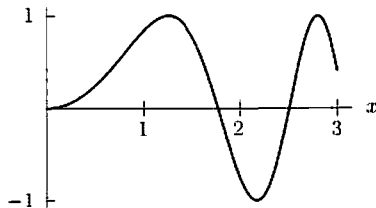

Figure 5.21: Graph of $f'(x) = \sin(x^2)$

- (b) The change in $f(x)$ between $x = 0$ and $x = 1$ is given by the Fundamental Theorem of Calculus:

$$f(1) - f(0) = \int_0^1 \sin(x^2) dx = 0.310.$$

Since $f(0) = 2$, we have

$$f(1) = 2 + 0.310 = 2.310.$$

Similarly, since

$$f(2) - f(0) = \int_0^2 \sin(x^2) dx = 0.805,$$

we have

$$f(2) = 2 + 0.805 = 2.805.$$

Since

$$f(3) - f(0) = \int_0^3 \sin(x^2) dx = 0.774,$$

we have

$$f(3) = 2 + 0.774 = 2.774.$$

The results are shown in the table.

x	0	1	2	3
$f(x)$	2	2.310	2.805	2.774

Problems

4. Note that $\int_a^b g(x) dx = \int_a^b g(t) dt$. Thus, we have

$$\int_a^b (f(x) + g(x)) dx = \int_a^b f(x) dx + \int_a^b g(x) dx = 8 + 2 = 10.$$

5. Note that $\int_a^b f(z) dz = \int_a^b f(x) dx$. Thus, we have

$$\int_a^b cf(z) dz = c \int_a^b f(z) dz = 8c.$$

6. Note that $\int_a^b (g(x))^2 dx = \int_a^b (g(t))^2 dt$. Thus, we have

$$\int_a^b ((f(x))^2 - (g(x))^2) dx = \int_a^b (f(x))^2 dx - \int_a^b (g(x))^2 dx = 12 - 3 = 9.$$

7. We have

$$\int_a^b (f(x))^2 dx - \left(\int_a^b f(x) dx \right)^2 = 12 - 8^2 = -52.$$

8. We write

$$\begin{aligned} \int_a^b (c_1g(x) + c_2f(x))^2 dx &= \int_a^b (c_1g(x) + c_2^2(f(x))^2) dx \\ &= \int_a^b c_1g(x) dx + \int_a^b c_2^2(f(x))^2 dx \\ &= c_1 \int_a^b g(x) dx + c_2^2 \int_a^b (f(x))^2 dx \\ &= c_1(2) + c_2^2(12) = 2c_1 + 12c_2^2. \end{aligned}$$

9. The graph of $y = f(x - 5)$ is the graph of $y = f(x)$ shifted to the right by 5. Since the limits of integration have also shifted by 5 (to $a + 5$ and $b + 5$), the areas corresponding to $\int_{a+5}^{b+5} f(x - 5) dx$ and $\int_a^b f(x) dx$ are the same. Thus,

$$\int_{a+5}^{b+5} f(x - 5) dx = \int_a^b f(x) dx = 8.$$

10. We know that we can divide the integral up as follows:

$$\int_0^3 f(x) dx = \int_0^1 f(x) dx + \int_1^3 f(x) dx.$$

The graph suggests that f is an even function for $-1 \leq x \leq 1$, so $\int_{-1}^1 f(x) dx = 2 \int_0^1 f(x) dx$. Substituting this in to the preceding equation, we have

$$\int_0^3 f(x) dx = \frac{1}{2} \int_{-1}^1 f(x) dx + \int_1^3 f(x) dx.$$

11. (a) For $0 \leq x \leq 3$, we have

$$\text{Average value} = \frac{1}{3-0} \int_0^3 f(x) dx = \frac{1}{3}(6) = 2.$$

- (b) If $f(x)$ is even, the graph is symmetric about the y -axis. For example, see Figure 5.22. By symmetry, the area between $x = -3$ and $x = 3$ is twice the area between $x = 0$ and $x = 3$, so

$$\int_{-3}^3 f(x) dx = 2(6) = 12.$$

Thus for $-3 \leq x \leq 3$, we have

$$\text{Average value} = \frac{1}{3 - (-3)} \int_{-3}^3 f(x) dx = \frac{1}{6}(12) = 2.$$

The graph confirms that the average value between $x = -3$ and $x = 3$ is the same as the average value between $x = 0$ and $x = 3$, which is 2.

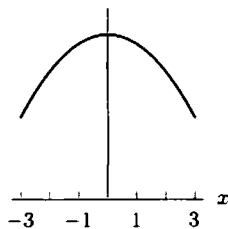

Figure 5.22

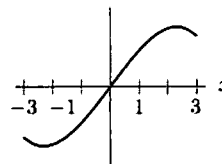

Figure 5.23

- (c) If $f(x)$ is odd, then the graph is symmetric about the origin. For example, see Figure 5.23. By symmetry, the area above the x -axis cancels out the area below the x -axis, so

$$\int_{-3}^3 f(x) dx = 0.$$

Thus for $-3 \leq x \leq 3$, we have

$$\text{Average value} = \frac{1}{3 - (-3)} \int_{-3}^3 f(x) dx = \frac{1}{6}(0) = 0.$$

The graph confirms that the average value between $x = -3$ and $x = 3$ is zero.

12. (a) $\int_{-1}^1 e^{x^2} dx > 0$, since $e^{x^2} > 0$, and $\int_{-1}^1 e^{x^2} dx$ represents the area below the curve $y = e^{x^2}$.
 (b) Looking at the figure below, we see that $\int_0^1 e^{x^2} dx$ represents the area under the curve. This area is clearly greater than zero, but it is less than e since it fits inside a rectangle of width 1 and height e (with room to spare). Thus

$$0 < \int_0^1 e^{x^2} dx < e < 3.$$

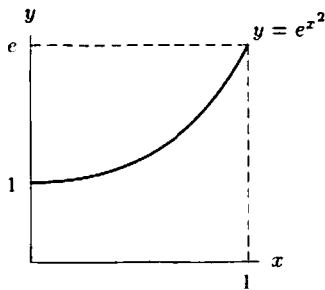

13. (a) The integrand is positive, so the integral can't be negative.
 (b) The integrand ≥ 0 . If the integral = 0, then the integrand must be identically 0, which isn't true.
14. By the Fundamental Theorem,

$$f(1) - f(0) = \int_0^1 f'(x) dx,$$

Since $f'(x)$ is negative for $0 \leq x \leq 1$, this integral must be negative and so $f(1) < f(0)$.

15. First rewrite each of the quantities in terms of f' , since we have the graph of f' . If A_1 and A_2 are the positive areas shown in Figure 5.24:

$$\begin{aligned} f(3) - f(2) &= \int_2^3 f'(t) dt = -A_1 \\ f(4) - f(3) &= \int_3^4 f'(t) dt = -A_2 \\ \frac{f(4) - f(2)}{2} &= \frac{1}{2} \int_2^4 f'(t) dt = -\frac{A_1 + A_2}{2} \end{aligned}$$

Since Area $A_1 >$ Area A_2 ,

$$A_2 < \frac{A_1 + A_2}{2} < A_1$$

so

$$-A_1 < -\frac{A_1 + A_2}{2} < -A_2$$

and therefore

$$f(3) - f(2) < \frac{f(4) - f(2)}{2} < f(4) - f(3).$$

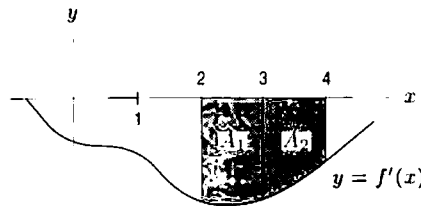
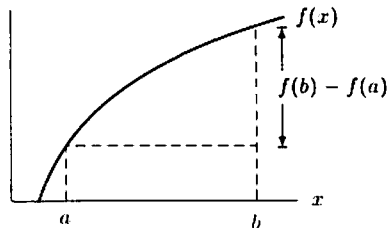
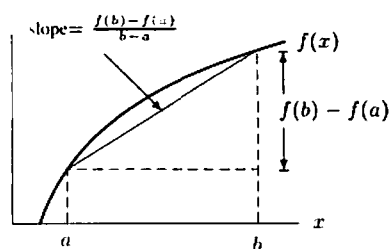

Figure 5.24

16. (a) 0, since the integrand is an odd function and the limits are symmetric around 0.
 (b) 0, since the integrand is an odd function and the limits are symmetric around 0.
- 17.



- 18.



19.

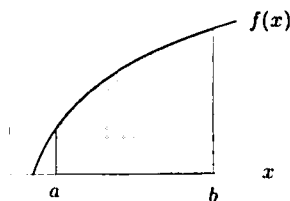

20.

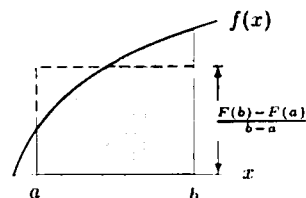

Note that we are using the interpretation of the definite integral as the length of the interval times the average value of the function on that interval, which we developed in Section 5.3.

$$21. (a) \frac{1}{\sqrt{2\pi}} \int_1^3 e^{-x^2/2} dx$$

$$= \frac{1}{\sqrt{2\pi}} \int_0^3 e^{-x^2/2} dx - \frac{1}{\sqrt{2\pi}} \int_0^1 e^{-x^2/2} dx$$

$$\approx 0.4987 - 0.3413 = 0.1574.$$

$$(b) \left(\text{by symmetry of } e^{x^2/2} \right) \quad \frac{1}{\sqrt{2\pi}} \int_{-2}^3 e^{-x^2/2} dx = \frac{1}{\sqrt{2\pi}} \int_{-2}^0 e^{-x^2/2} dx + \frac{1}{\sqrt{2\pi}} \int_0^3 e^{-x^2/2} dx$$

$$= \frac{1}{\sqrt{2\pi}} \int_0^2 e^{-x^2/2} dx + \frac{1}{\sqrt{2\pi}} \int_0^3 e^{-x^2/2} dx$$

$$\approx 0.4772 + 0.4987 = 0.9759.$$

$$22. \text{ By the given property, } \int_a^a f(x) dx = - \int_a^a f(x) dx, \text{ so } 2 \int_a^a f(x) dx = 0. \text{ Thus } \int_a^a f(x) dx = 0.$$

23. We know that the average value of $v(x) = 4$, so

$$\frac{1}{6-1} \int_1^6 v(x) dx = 4. \text{ and thus } \int_1^6 v(x) dx = 20.$$

Similarly, we are told that

$$\frac{1}{8-6} \int_6^8 v(x) dx = 5, \text{ so } \int_6^8 v(x) dx = 10.$$

The average value for $1 \leq x \leq 8$ is given by

$$\text{Average value} = \frac{1}{8-1} \int_1^8 v(x) dx = \frac{1}{7} \left(\int_1^6 v(x) dx + \int_6^8 v(x) dx \right) = \frac{20+10}{7} = \frac{30}{7}.$$

Solutions for Chapter 5 Review

Exercises

1. (a) We calculate the right- and left-hand sums as follows:

$$\text{Left} = 2[80 + 52 + 28 + 10] = 340 \text{ ft.}$$

$$\text{Right} = 2[52 + 28 + 10 + 0] = 180 \text{ ft.}$$

Our best estimate will be the average of these two sums,

$$\text{Best} = \frac{\text{Left} + \text{Right}}{2} = \frac{340 + 180}{2} = 260 \text{ ft.}$$

(b) Since v is decreasing throughout,

$$\begin{aligned}\text{Left} - \text{Right} &= \Delta t \cdot [f(0) - f(8)] \\ &= 80\Delta t.\end{aligned}$$

Since our best estimate is the average of Left and Right, the maximum error is $(80)\Delta t/2$. For $(80)\Delta t/2 \leq 20$, we must have $\Delta t \leq 1/2$. In other words, we must measure the velocity every 0.5 second.

2. $\int_0^{20} f(x) dx$ is equal to the area shaded in the figure below. We estimate the area by counting boxes. There are about 15 boxes and each box represents 4 square units, so the area shaded is about 60. We have

$$\int_0^{20} f(x) dx \approx 60.$$

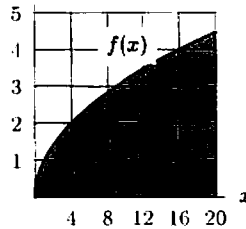

3. By counting squares and fractions of squares, we find that the area under the graph appears to be around 310 (miles/hour) sec, within about 10. So the distance traveled was about $310 \left(\frac{5280}{3600}\right) \approx 455$ feet, within about $10 \left(\frac{5280}{3600}\right) \approx 15$ feet. (Note that 455 feet is about 0.086 miles)

4. We know that

$$\int_{-3}^5 f(x) dx = \text{Area above the axis} - \text{Area below the axis}.$$

The area above the axis is about 3 boxes. Since each box has area $(1)(5) = 5$, the area above the axis is about $(3)(5) = 15$. The area below the axis is about 11 boxes, giving an area of about $(11)(5) = 55$. We have

$$\int_{-3}^5 f(x) dx \approx 15 - 55 = -40.$$

5. We take $\Delta t = 20$. Then:

$$\begin{aligned}\text{Left-hand sum} &= 1.2(20) + 2.8(20) + 4.0(20) + 4.7(20) + 5.1(20) \\ &= 356.\end{aligned}$$

$$\begin{aligned}\text{Right-hand sum} &= 2.8(20) + 4.0(20) + 4.7(20) + 5.1(20) + 5.2(20) \\ &= 436.\end{aligned}$$

$$\int_0^{100} f(t) dt \approx \text{Average} = \frac{356 + 436}{2} = 396.$$

6. (a) The total area between $f(x)$ and the x -axis is the sum of the two given areas, so

$$\text{Area} = 7 + 6 = 13.$$

(b) To find the integral, we note that from $x = 3$ to $x = 5$, the function lies below the x -axis, and hence makes a negative contribution to the integral. So

$$\int_0^5 f(x) dx = \int_0^3 f(x) dx + \int_3^5 f(x) dx = 7 - 6 = 1.$$

7. Since $v(t) \geq 0$ for $0 \leq t \leq 3$, we can find the total distance traveled by integrating the velocity from $t = 0$ to $t = 3$:

$$\begin{aligned}\text{Distance} &= \int_0^3 \ln(t^2 + 1) dt \\ &= 3.4, \text{ evaluating this integral by calculator.}\end{aligned}$$

8. Distance traveled $= \int_0^{1.1} \sin(t^2) dt \approx 0.40$.

9. The x intercepts of $y = x^2 - 9$ are $x = -3$ and $x = 3$, and since the graph is below the x axis on the interval $[-3, 3]$.

$$\text{Area} = - \int_{-3}^3 (x^2 - 9) dx = 36.00.$$

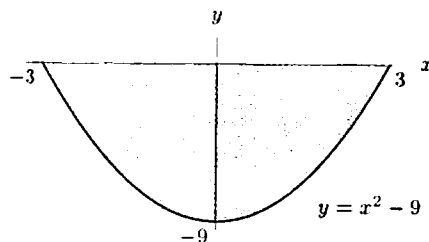

10. Since x intercepts are $x = 0, \pi, 2\pi, \dots$

$$\text{Area} = \int_0^\pi \sin x dx = 2.00.$$

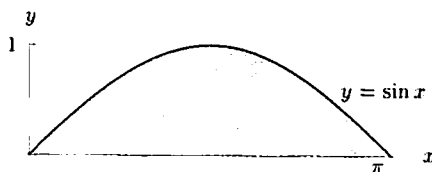

11. The x intercepts of $y = 4 - x^2$ are $x = -2$ and $x = 2$, and the graph is above the x -axis on the interval $[-2, 2]$.

$$\text{Area} = \int_{-2}^2 (4 - x^2) dx = 10.67.$$

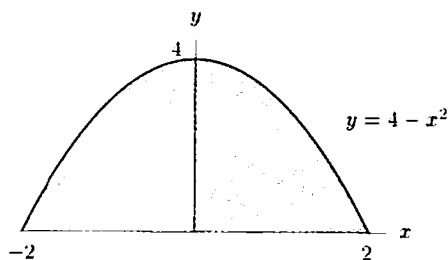

12. Since the θ intercepts of $y = \sin \theta$ are $\theta = 0, \pi, 2\pi, \dots$

$$\text{Area} = \int_0^\pi 1 d\theta - \int_0^\pi \sin \theta d\theta = \pi - 2 \approx 1.14.$$

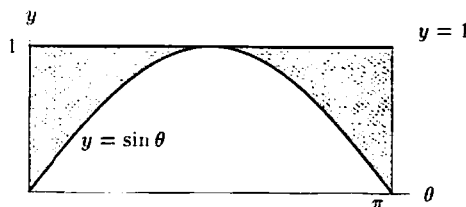

13. The graph of $y = -x^2 + 5x - 4$ is shown in Figure 5.25. We wish to find the area shaded. Since the graph crosses the x -axis at $x = 1$, we must split the integral at $x = 1$. For $x < 1$, the graph is below the x -axis, so the area is the negative of the integral. Thus

$$\text{Area shaded} = - \int_0^1 (-x^2 + 5x - 4) dx + \int_1^3 (-x^2 + 5x - 4) dx.$$

Using a calculator or computer, we find

$$\int_0^1 (-x^2 + 5x - 4) dx = -1.8333 \quad \text{and} \quad \int_1^3 (-x^2 + 5x - 4) dx = 3.3333.$$

Thus,

$$\text{Area shaded} = 1.8333 + 3.3333 = 5.1666.$$

(Notice that $\int_0^3 f(x) dx = -1.8333 + 3.3333 = 1.5$, but the value of this integral is not the area shaded.)

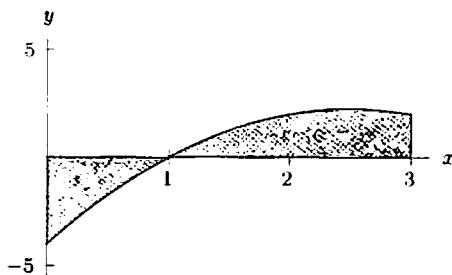

Figure 5.25

Problems

14. Using properties of the definite integral, we have:

$$\begin{aligned}\int_2^5 (2f(x) + 3) dx &= 17 \\ 2 \int_2^5 f(x) dx + 3 \int_2^5 1 dx &= 17 \\ 2 \int_2^5 f(x) dx + 3 \cdot 3 &= 17 \\ 2 \int_2^5 f(x) dx &= 8 \\ \int_2^5 f(x) dx &= 4.\end{aligned}$$

15. We use left- and right-hand sums to estimate the total amount of coal produced during this period:

$$\text{Left sum} = (10.82)(5) + (13.06)(5) + (14.61)(5) + (14.99)(5) + (18.60)(5) + (19.33)(5) = 457.05.$$

$$\text{Right sum} = (13.06)(5) + (14.61)(5) + (14.99)(5) + (18.60)(5) + (19.33)(5) + (22.46)(5) = 515.25.$$

We see that

$$\text{Total amount of coal produced} \approx \frac{457.05 + 515.25}{2} = 486.15 \text{ quadrillion BTU.}$$

The total amount of coal produced is the definite integral of the rate of coal production $r = f(t)$ given in the table. Since t is in years since 1960, the limits of integration are $t = 0$ and $t = 30$. We have

$$\text{Total amount of coal produced} = \int_0^{30} f(t) dt \text{ quadrillion BTU.}$$

16. (a) Note that the rate $r(t)$ sometimes increases and sometimes decreases in the interval. We can calculate an upper estimate of the volume by choosing $\Delta t = 5$ and then choosing the highest value of $r(t)$ on each interval, and similarly a lower estimate by choosing the lowest value of $r(t)$ on each interval:

$$\text{Upper estimate} = 5[20 + 24 + 24] = 340 \text{ liters.}$$

$$\text{Lower estimate} = 5[12 + 20 + 16] = 240 \text{ liters.}$$

- (b) A graph of $r(t)$ along with the areas represented by the choices of $r(t)$ in calculating the lower estimate is shown in Figure 5.26.

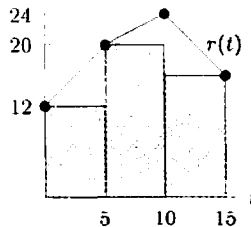

Figure 5.26

17. From $t = 0$ to $t = 3$, you are moving away from home ($v > 0$); thereafter you move back toward home. So you are the farthest from home at $t = 3$. To find how far you are then, we can measure the area under the v curve as about 9 squares, or $9 \cdot 10 \text{ km/hr} \cdot 1 \text{ hr} = 90 \text{ km}$. To find how far away from home you are at $t = 5$, we measure the area from $t = 3$ to $t = 5$ as about 25 squares, except that this distance is directed toward home, giving a total distance from home during the trip of $90 - 25 = 65 \text{ km}$.

18. (a) At $t = 20$ minutes, she stops moving toward the lake (with $v > 0$) and starts to move away from the lake (with $v < 0$). So at $t = 20$ minutes the cyclist turns around.
- (b) The cyclist is going the fastest when v has the greatest magnitude, either positive or negative. Looking at the graph, we can see that this occurs at $t = 40$ minutes, when $v = -25$ and the cyclist is pedaling at 25 km/hr away from the lake.
- (c) From $t = 0$ to $t = 20$ minutes, the cyclist comes closer to the lake, since $v > 0$; thereafter, $v < 0$ so the cyclist moves away from the lake. So at $t = 20$ minutes, the cyclist comes the closest to the lake. To find out how close she is, note that between $t = 0$ and $t = 20$ minutes the distance she has come closer is equal to the area under the graph of v . Each box represents $5/6$ of a kilometer, and there are about 2.5 boxes under the graph, giving a distance of about 2 km. Since she was originally 5 km away, she then is about $5 - 2 = 3$ km from the lake.
- (d) At $t = 20$ minutes she turns around, since v changes sign then. Since the area below the t -axis is greater than the area above, the farthest she is from the lake is at $t = 60$ minutes. Between $t = 20$ and $t = 60$ minutes, the area under the graph is about 10.8 km. (Since $13 \text{ boxes} \cdot 5/6 = 10.8$.) So at $t = 60$ she will be about $3 + 10.8 = 13.8$ km from the lake.
19. Suppose $F(t)$ represents the total quantity of water in the water tower at time t , where t is in days since April 1. Then the graph shown in the problem is a graph of $F'(t)$. By the Fundamental Theorem,

$$F(30) - F(0) = \int_0^{30} F'(t) dt.$$

We can calculate the change in the quantity of water by calculating the area under the curve. If each box represents about 300 liters, there is about one box, or -300 liters, from $t = 0$ to $t = 12$, and 6 boxes, or about $+1800$ liters, from $t = 12$ to $t = 30$. Thus

$$\int_0^{30} F'(t) dt = 1800 - 300 = 1500,$$

so the final amount of water is given by

$$F(30) = F(0) + \int_0^{30} F'(t) dt = 12,000 + 1500 = 13,500 \text{ liters.}$$

20. All the integrals have positive values, since $f \geq 0$. The integral in (ii) is about one-half the integral in (i), due to the apparent symmetry of f . The integral in (iv) will be much larger than the integral in (i), since the two peaks of f^2 rise to 10,000. The integral in (iii) will be smaller than half of the integral in (i), since the peaks in $f^{1/2}$ will only rise to 10. So

$$\int_0^2 (f(x))^{1/2} dx < \int_0^1 f(x) dx < \int_0^2 f(x) dx < \int_0^2 (f(x))^2 dx.$$

21. (a) Clearly, the points where $x = \sqrt{\pi}$, $\sqrt{2\pi}$, $\sqrt{3\pi}$, $\sqrt{4\pi}$ are where the graph intersects the x -axis because $f(x) = \sin(x^2) = 0$ where x is the square root of some multiple of π .
- (b) Let $f(x) = \sin(x^2)$, and let A , B , C , and D be the areas of the regions indicated in the figure below. Then we see that $A > B > C > D$.

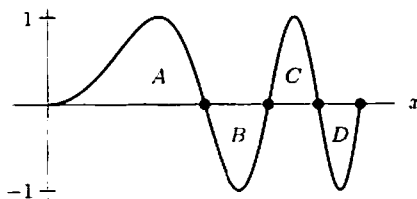

Note that

$$\begin{aligned} \int_0^{\sqrt{\pi}} f(x) dx &= A, & \int_0^{\sqrt{2\pi}} f(x) dx &= A - B, \\ \int_0^{\sqrt{3\pi}} f(x) dx &= A - B + C, & \text{and} & \int_0^{\sqrt{4\pi}} f(x) dx = A - B + C - D. \end{aligned}$$

It follows that

$$\int_0^{\sqrt{\pi}} f(x) dx = A > \int_0^{\sqrt{3\pi}} f(x) dx = A - (B - C) = A - B + C >$$

$$\int_0^{\sqrt{4\pi}} f(x) dx = A - B + C - D > \int_0^{\sqrt{2\pi}} f(x) dx = (A - B) > 0.$$

And thus the ordering is $n = 1, n = 3, n = 4,$ and $n = 2$ from largest to smallest. All the numbers are positive.

22. This integral represents the area of two triangles, each of base 1 and height 1. See Figure 5.27. Therefore:

$$\int_{-1}^1 |x| dx = \frac{1}{2} \cdot 1 \cdot 1 + \frac{1}{2} \cdot 1 \cdot 1 = 1.$$

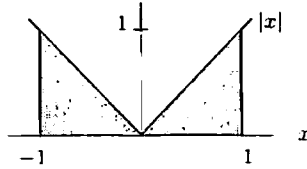

Figure 5.27

23. In Figure 5.28 the area A_1 is largest, A_2 is next, and A_3 is smallest. We have

$$I = \int_a^b f(x) dx = A_1. \quad II = \int_a^c f(x) dx = A_1 - A_2. \quad III = \int_a^e f(x) dx = A_1 - A_2 + A_3,$$

$$IV = \int_b^e f(x) dx = -A_2 + A_3. \quad V = \int_b^c f(x) dx = -A_2.$$

The relative sizes of $A_1, A_2,$ and A_3 mean that I is positive and largest, III is next largest (since $-A_2 + A_3$ is negative, but less negative than $-A_2$), II is next largest, but still positive (since A_1 is larger than A_2). The integrals IV and V are both negative, but V is more negative. Thus

$$V < IV < 0 < II < III < I.$$

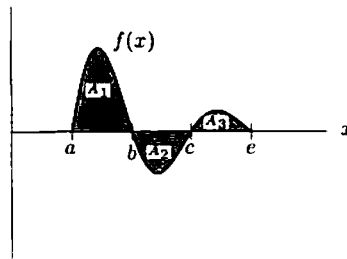

Figure 5.28

24. (a) For $-2 \leq x \leq 2,$ f is symmetrical about the y -axis, so $\int_{-2}^0 f(x) dx = \int_0^2 f(x) dx$ and $\int_{-2}^2 f(x) dx = 2 \int_0^2 f(x) dx.$
 (b) For any function $f,$ $\int_0^2 f(x) dx = \int_0^5 f(x) dx - \int_2^5 f(x) dx.$
 (c) Note that $\int_{-2}^0 f(x) dx = \frac{1}{2} \int_{-2}^2 f(x) dx,$ so $\int_0^5 f(x) dx = \int_{-2}^5 f(x) dx - \int_{-2}^0 f(x) dx = \int_{-2}^5 f(x) dx - \frac{1}{2} \int_{-2}^2 f(x) dx.$
25. (a) We know that $\int_2^5 f(x) dx = \int_0^5 f(x) dx - \int_0^2 f(x) dx.$ By symmetry, $\int_0^2 f(x) dx = \frac{1}{2} \int_{-2}^2 f(x) dx,$ so $\int_2^5 f(x) dx = \int_0^5 f(x) dx - \frac{1}{2} \int_{-2}^2 f(x) dx.$
 (b) $\int_2^5 f(x) dx = \int_{-2}^5 f(x) dx - \int_{-2}^2 f(x) dx = \int_{-2}^5 f(x) dx - 2 \int_{-2}^2 f(x) dx.$
 (c) Using symmetry again, $\int_0^2 f(x) dx = \frac{1}{2} \left(\int_{-2}^5 f(x) dx - \int_2^5 f(x) dx \right).$

26. The integrand is a linear function with value b_1 at the left-hand end. At the right-hand end the height is

$$b_1 + \frac{b_2 - b_1}{w} w = b_2.$$

See Figure 5.29. The integral gives the area of the right trapezoid bounded by the x -axis, the lines $x = 0$ and $x = w$, and the integrand. The value of the integral is the area of this trapezoid

$$\int_0^w \left(b_1 + \frac{b_2 - b_1}{w} x \right) dx = \frac{1}{2} w (b_1 + b_2).$$

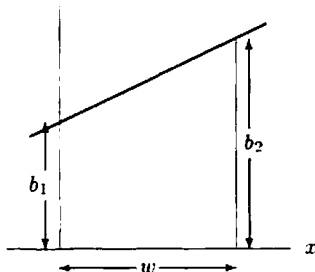

Figure 5.29

27. If $H(t)$ is the temperature of the coffee at time t , by the Fundamental Theorem of Calculus

$$\text{Change in temperature} = H(10) - H(0) = \int_0^{10} H'(t) dt = \int_0^{10} -7e^{-0.1t} dt.$$

Therefore,

$$H(10) = H(0) + \int_0^{10} -7(0.9^t) dt \approx 90 - 44.2 = 45.8^\circ\text{C}.$$

28. (a) Quantity used $= \int_0^5 f(t) dt$.
 (b) Using a left sum, our approximation is

$$32e^{0.05(0)} + 32e^{0.05(1)} + 32e^{0.05(2)} + 32e^{0.05(3)} + 32e^{0.05(4)} = 177.27.$$

Since f is an increasing function, this represents an underestimate.

- (c) Each term is a lower estimate of one year's consumption of oil.

29. The change in the amount of water is the integral of rate of change, so we have

$$\text{Number of liters pumped out} = \int_0^{60} (5 - 5e^{-0.12t}) dt = 258.4 \text{ liters.}$$

Since the tank contained 1000 liters of water initially, we see that

$$\text{Amount in tank after one hour} = 1000 - 258.4 = 741.6 \text{ liters.}$$

30. (a) Train A starts earlier than Train B , and stops later. At every moment Train A is going faster than Train B . Both trains increase their speed at a constant rate through the first half of their trip and slow down during the second half. Both trains reach their maximum speed at the same time. The area under the velocity graph for Train A is larger than the area under the velocity graph for Train B , meaning that Train A travels farther—as would be expected, given that its speed is always higher than B 's.
 (b) (i) The maximum velocity is read off the vertical axis. The graph for Train A appears to go about twice as high as the graph for Train B ; see Figure 5.30. So

$$\frac{\text{Maximum velocity of Train } A}{\text{Maximum velocity of Train } B} = \frac{v_A}{v_B} \approx 2.$$

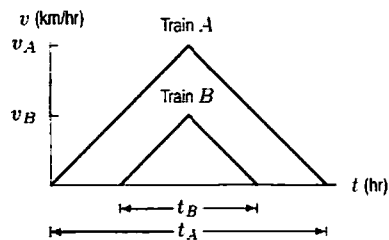

Figure 5.30

- (ii) The time of travel is the horizontal distance between the start and stop times (the two t -intercepts). The horizontal distance for Train A appears to be about twice the corresponding distance for Train B ; see Figure 5.30. So

$$\frac{\text{Time traveled by Train } A}{\text{Time traveled by Train } B} = \frac{t_A}{t_B} \approx 2.$$

- (iii) The distance traveled by each train is given by the area under its graph. Since the area of triangle is $\frac{1}{2} \cdot \text{Base} \cdot \text{Height}$, and since the base and height for Train A is approximately twice that for Train B , we have

$$\frac{\text{Distance traveled by Train } A}{\text{Distance traveled by Train } B} = \frac{\frac{1}{2} \cdot v_A \cdot t_A}{\frac{1}{2} \cdot v_B \cdot t_B} \approx 2 \cdot 2 = 4.$$

31. (a) V, since the slope is constant.
 (b) IV, since the net area under this curve is the most negative.
 (c) III, since the area under the curve is largest.
 (d) II, since the steepest ascent at $t = 0$ occurs on this curve.
 (e) III, since average velocity is (total distance)/5, and III moves the largest total distance.
 (f) I, since average acceleration is $\frac{1}{5} \int_0^5 v'(t) dt = \frac{1}{5}(v(5) - v(0))$, and in I, the velocity increases the most from start ($t = 0$) to finish ($t = 5$).
32. Let C be the rate of the flow through the hose. At $t = t_0$, the volume of water in the tank is equal to the area under the lower curve (flow rate through the hose) minus the area under the upper curve (flow rate through the hole) in the region to the left of the vertical line $t = t_0$. Since the overlap of these regions cancels, the volume is also equal to $5C$ (that's the area under the lower curve from $t = 0$ to $t = 5$) minus the region bounded by the upper curve, the horizontal line of height C , the vertical line $t = t_0$, and the vertical line $t = 5$. If $t_0 > 15$, movement of the vertical line $t = t_0$ doesn't change the area of the latter region, so the difference becomes constant. Thus the volume of water in the tank becomes constant, and the physical system is in a steady state.

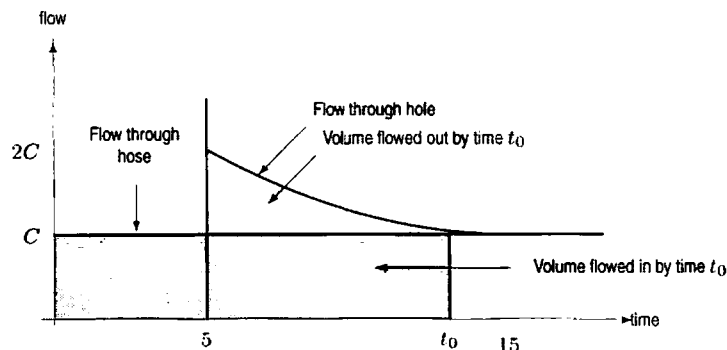

33. (a) About 300 meter³/sec.
 (b) About 250 meter³/sec.
 (c) Looking at the graph, we can see that the 1996 flood reached its maximum just between March and April, for a high of about 1250 meter³/sec. Similarly, the 1957 flood reached its maximum in mid-June, for a maximum flow rate of 3500 meter³/sec.

- (d) The 1996 flood lasted about $1/3$ of a month, or about 10 days. The 1957 flood lasted about 4 months.
 (e) The area under the controlled flood graph is about $2/3$ box. Each box represents $500 \text{ meter}^3/\text{sec}$ for one month. Since

$$\begin{aligned} 1 \text{ month} &= 30 \frac{\text{days}}{\text{month}} \cdot 24 \frac{\text{hours}}{\text{day}} \cdot 60 \frac{\text{minutes}}{\text{hour}} \cdot 60 \frac{\text{seconds}}{\text{minute}} \\ &= 2.592 \cdot 10^6 \approx 3 \cdot 10^6 \text{ seconds.} \end{aligned}$$

each box represents

$$\text{Flow} \approx (500 \text{ meter}^3/\text{sec}) \cdot (2.6 \cdot 10^6 \text{ sec}) = 13 \cdot 10^8 \text{ meter}^3 \text{ of water.}$$

So, for the artificial flood,

$$\text{Additional flow} \approx \frac{2}{3} \cdot 13 \cdot 10^8 = 9 \cdot 10^8 \text{ meter}^3 \approx 10^9 \text{ meter}^3.$$

- (f) The 1957 flood released a volume of water represented by about 12 boxes above the $250 \text{ meter}/\text{sec}$ baseline. Thus, for the natural flood,

$$\text{Additional flow} \approx 12 \cdot 15 \cdot 10^8 = 1.8 \cdot 10^{10} \approx 2 \cdot 10^{10} \text{ meter}^3.$$

So, the natural flood was nearly 20 times larger than the controlled flood and lasted much longer.

34. (a) The acceleration is positive for $0 \leq t < 40$ and for a tiny period before $t = 60$, since the slope is positive over these intervals. Just to the left of $t = 40$, it looks like the acceleration is approaching 0. Between $t = 40$ and a moment just before $t = 60$, the acceleration is negative.
 (b) The maximum altitude was about 500 feet, when t was a little greater than 40 (here we are estimating the area under the graph for $0 \leq t \leq 42$).
 (c) The acceleration is greatest when the slope of the velocity is most positive. This happens just before $t = 60$, where the magnitude of the velocity is plunging and the direction of the acceleration is positive, or up.
 (d) The deceleration is greatest when the slope of the velocity is most negative. This happens just after $t = 40$.
 (e) After the Montgolfier Brothers hit their top climbing speed (at $t = 40$), they suddenly stopped climbing and started to fall. This suggests some kind of catastrophe—the flame going out, the balloon ripping, etc. (In actual fact, in their first flight in 1783, the material covering their balloon, held together by buttons, ripped and the balloon landed in flames.)
 (f) The total change in altitude for the Montgolfiers and their balloon is the definite integral of their velocity, or the total area under the given graph (counting the part after $t = 42$ as negative, of course). As mentioned before, the total area of the graph for $0 \leq t \leq 42$ is about 500. The area for $t > 42$ is about 220. So subtracting, we see that the balloon finished 280 feet or so higher than where it began.
35. (a) The mouse changes direction (when its velocity is zero) at about times 17, 23, and 27.
 (b) The mouse is moving most rapidly to the right at time 10 and most rapidly to the left at time 40.
 (c) The mouse is farthest to the right when the integral of the velocity, $\int_0^t v(t) dt$, is most positive. Since the integral is the sum of the areas above the axis minus the areas below the axis, the integral is largest when the velocity is zero at about 17 seconds. The mouse is farthest to the left of center when the integral is most negative at 40 seconds.
 (d) The mouse's speed decreases during seconds 10 to 17, from 20 to 23 seconds, and from 24 seconds to 27 seconds.
 (e) The mouse is at the center of the tunnel at any time t for which the integral from 0 to t of the velocity is zero. This is true at time 0 and again somewhere around 35 seconds.
36. (a) When the aircraft is climbing at $v \text{ ft}/\text{min}$, it takes $1/v$ minutes to climb 1 foot. Therefore

$$\begin{aligned} \text{Lower estimate} &= \left(\frac{1 \text{ min}}{925 \text{ ft}}\right) (1000 \text{ ft}) + \left(\frac{1 \text{ min}}{875 \text{ ft}}\right) (1000 \text{ ft}) + \cdots + \left(\frac{1 \text{ min}}{490 \text{ ft}}\right) (1000 \text{ ft}) \\ &\approx 14.73 \text{ minutes.} \\ \text{Upper estimate} &= \left(\frac{1 \text{ min}}{875 \text{ ft}}\right) (1000 \text{ ft}) + \left(\frac{1 \text{ min}}{830 \text{ ft}}\right) (1000 \text{ ft}) + \cdots + \left(\frac{1 \text{ min}}{440 \text{ ft}}\right) (1000 \text{ ft}) \\ &\approx 15.93 \text{ minutes.} \end{aligned}$$

Note: The Pilot Operating Manual for this aircraft gives 16 minutes as the estimated time required to climb to 10,000 ft.

- (b) The difference between upper and lower sums with $\Delta x = 500 \text{ ft}$ would be

$$\text{Difference} = \left(\frac{1 \text{ min}}{440 \text{ ft}} - \frac{1 \text{ min}}{925 \text{ ft}}\right) (500 \text{ ft}) = 0.60 \text{ minutes.}$$

37. The graph of rate against time is the straight line shown in Figure 5.31. Since the shaded area is 270, we have

$$\frac{1}{2}(10 + 50) \cdot t = 270$$

$$t = \frac{270}{60} \cdot 2 = 9 \text{ years}$$

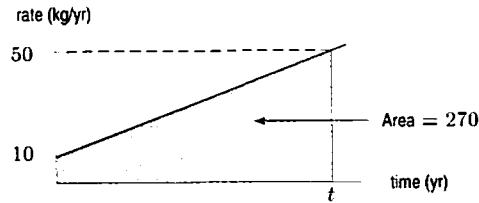

Figure 5.31

CAS Challenge Problems

38. (a) We have $\Delta x = (1 - 0)/n = 1/n$ and $x_i = 0 + i \cdot \Delta x = i/n$. So we get

$$\text{Right-hand sum} = \sum_{i=1}^n (x_i)^4 \Delta x = \sum_{i=1}^n \left(\frac{i}{n}\right)^4 \left(\frac{1}{n}\right) = \sum_{i=1}^n \frac{i^4}{n^5}.$$

(b) The CAS gives

$$\text{Right-hand sum} = \sum_{i=1}^n \frac{i^4}{n^5} = \frac{6n^4 + 15n^3 + 10n^2 - 1}{30n^4}.$$

(The results may look slightly different depending on the CAS you use.)

(c) Using a CAS or by hand, we get

$$\lim_{n \rightarrow \infty} \frac{6n^4 + 15n^3 + 10n^2 - 1}{30n^4} = \lim_{n \rightarrow \infty} \frac{6n^4}{30n^4} = \frac{1}{5}.$$

The numerator is dominated by the highest power term, which is $6n^4$, so when n is large, the ratio behaves like $6n^4/30n^4 = 1/5$ as $n \rightarrow \infty$. Thus we see that

$$\int_0^1 x^4 dx = \frac{1}{5}.$$

39. (a) A Riemann sum with n subdivisions of $[0, 1]$ has $\Delta x = 1/n$ and $x_i = i/n$. Thus,

$$\text{Right-hand sum} = \sum_{i=1}^n \left(\frac{i}{n}\right)^5 \left(\frac{1}{n}\right) = \sum_{i=1}^n \frac{i^5}{n^6}.$$

(b) A CAS gives

$$\text{Right-hand sum} = \sum_{i=1}^n \frac{i^5}{n^6} = \frac{2n^4 + 6n^3 + 5n^2 - 1}{12n^4}.$$

(c) Taking the limit by hand or using a CAS gives

$$\lim_{n \rightarrow \infty} \frac{2n^4 + 6n^3 + 5n^2 - 1}{12n^4} = \lim_{n \rightarrow \infty} \frac{2n^4}{12n^4} = \frac{1}{6}.$$

The numerator is dominated by the highest power term, which is $2n^4$, so the ratio behaves like $2n^4/12n^4 = 1/6$, as $n \rightarrow \infty$. Thus we see that

$$\int_0^1 x^5 dx = \frac{1}{6}.$$

40. (a) Since the length of the interval of integration is $2 - 1 = 1$, the width of each subdivision is $\Delta t = 1/n$. Thus the endpoints of the subdivision are

$$t_0 = 1, \quad t_1 = 1 + \Delta t = 1 + \frac{1}{n}, \quad t_2 = 1 + 2\Delta t = 1 + \frac{2}{n}, \dots$$

$$t_i = 1 + i\Delta t = 1 + \frac{i}{n}, \dots, \quad t_{n-1} = 1 + (n-1)\Delta t = 1 + \frac{n-1}{n}.$$

Thus, since the integrand is $f(t) = t$,

$$\text{Left-hand sum} = \sum_{i=0}^{n-1} f(t_i)\Delta t = \sum_{i=0}^{n-1} t_i\Delta t = \sum_{i=0}^{n-1} \left(1 + \frac{i}{n}\right) \frac{1}{n} = \sum_{i=0}^{n-1} \frac{n+i}{n^2}.$$

- (b) The CAS finds the formula for the Riemann sum

$$\sum_{i=0}^{n-1} \frac{n+i}{n^2} = \frac{\frac{(-1+n)n}{2} + n^2}{n^2} = \frac{3}{2} - \frac{1}{2n}.$$

- (c) Taking the limit as $n \rightarrow \infty$

$$\lim_{n \rightarrow \infty} \left(\frac{3}{2} - \frac{1}{2n}\right) = \lim_{n \rightarrow \infty} \frac{3}{2} - \lim_{n \rightarrow \infty} \frac{1}{2n} = \frac{3}{2} + 0 = \frac{3}{2}.$$

- (d) The shape under the graph of $y = t$ between $t = 1$ and $t = 2$ is a trapezoid of width 1, height 1 on the left and 2 on the right. So its area is $1 \cdot (1 + 2)/2 = 3/2$. This is the same answer we got by computing the definite integral.
41. (a) Since the length of the interval of integration is $2 - 1 = 1$, the width of each subdivision is $\Delta t = 1/n$. Thus the endpoints of the subdivision are

$$t_0 = 1, \quad t_1 = 1 + \Delta t = 1 + \frac{1}{n}, \quad t_2 = 1 + 2\Delta t = 1 + \frac{2}{n}, \dots$$

$$t_i = 1 + i\Delta t = 1 + \frac{i}{n}, \dots, \quad t_{n-1} = 1 + (n-1)\Delta t = 1 + \frac{n-1}{n}.$$

Thus, since the integrand is $f(t) = t^2$,

$$\text{Left-hand sum} = \sum_{i=0}^{n-1} f(t_i)\Delta t = \sum_{i=0}^{n-1} t_i^2\Delta t = \sum_{i=0}^{n-1} \left(1 + \frac{i}{n}\right)^2 \frac{1}{n} = \sum_{i=0}^{n-1} \frac{(n+i)^2}{n^3}.$$

- (b) Using a CAS to find the sum, we get

$$\sum_{i=0}^{n-1} \frac{(n+i)^2}{n^3} = \frac{(-1+2n)(-1+7n)}{6n^2} = \frac{7}{3} + \frac{1}{6n^2} - \frac{3}{2n}.$$

- (c) Taking the limit as $n \rightarrow \infty$

$$\lim_{n \rightarrow \infty} \left(\frac{7}{3} + \frac{1}{6n^2} - \frac{3}{2n}\right) = \lim_{n \rightarrow \infty} \frac{7}{3} + \lim_{n \rightarrow \infty} \frac{1}{6n^2} - \lim_{n \rightarrow \infty} \frac{3}{2n} = \frac{7}{3} + 0 + 0 = \frac{7}{3}.$$

- (d) We have calculated $\int_1^2 t^2 dt$ using Riemann sums. Since t^2 is above the t -axis between $t = 1$ and $t = 2$, this integral is the area; so the area is $7/3$.
42. (a) Since the length of the interval of integration is π , the width of each subdivision is $\Delta x = \pi/n$. Thus the endpoints of the subdivision are

$$x_0 = 0, \quad x_1 = 0 + \Delta x = \frac{\pi}{n}, \quad x_2 = 0 + 2\Delta x = \frac{2\pi}{n}, \dots$$

$$x_i = 0 + i\Delta x = \frac{i\pi}{n}, \quad \dots, \quad x_n = 0 + n\Delta x = \frac{n\pi}{n} = \pi.$$

Thus, since the integrand is $f(x) = \sin x$,

$$\text{Right-hand sum} = \sum_{i=1}^n f(x_i)\Delta x = \sum_{i=1}^n \sin(x_i)\Delta x = \sum_{i=1}^n \sin\left(\frac{i\pi}{n}\right) \frac{\pi}{n}.$$

(b) If the CAS can evaluate this sum, we get

$$\sum_{i=1}^n \sin\left(\frac{i\pi}{n}\right) \frac{\pi}{n} = \frac{\pi \cot(\pi/2n)}{n} = \frac{\pi \cos(\pi/2n)}{n \sin(\pi/2n)}.$$

(c) Using the computer algebra system, we find that

$$\lim_{n \rightarrow \infty} \frac{\pi \cos(\pi/2n)}{n \sin(\pi/2n)} = 2.$$

(d) The computer algebra system gives

$$\int_0^\pi \sin x \, dx = 2.$$

43. (a) A CAS gives

$$\int_a^b \sin(cx) \, dx = \frac{\cos(ac)}{c} - \frac{\cos(bc)}{c}.$$

(b) If $F(x)$ is an antiderivative of $\sin(cx)$, then the Fundamental Theorem of Calculus says that

$$\int_a^b \sin(cx) \, dx = F(b) - F(a).$$

Comparing this with the answer to part (a), we see that

$$F(b) - F(a) = \frac{\cos(ac)}{c} - \frac{\cos(bc)}{c} = \left(-\frac{\cos(cb)}{c}\right) - \left(-\frac{\cos(ca)}{c}\right).$$

This suggests that

$$F(x) = -\frac{\cos(cx)}{c}.$$

Taking the derivative confirms this:

$$\frac{d}{dx} \left(-\frac{\cos(cx)}{c}\right) = \sin(cx).$$

44. (a) Different systems may give different answers. A typical answer is

$$\int_a^c \frac{x}{1+bx^2} \, dx = \frac{\ln\left(\frac{|c^2b+1|}{|a^2b+1|}\right)}{2b}.$$

Some CASs may not have the absolute values in the answer; since $b > 0$, the answer is correct without the absolute values.

(b) Using the properties of logarithms, we can rewrite the answer to part (a) as

$$\int_a^c \frac{x}{1+bx^2} \, dx = \frac{\ln|c^2b+1| - \ln|a^2b+1|}{2b} = \frac{\ln|c^2b+1|}{2b} - \frac{\ln|a^2b+1|}{2b}.$$

If $F(x)$ is an antiderivative of $x/(1+bx^2)$, then the Fundamental Theorem of Calculus says that

$$\int_a^c \frac{x}{1+bx^2} \, dx = F(c) - F(a).$$

Thus

$$F(c) - F(a) = \frac{\ln|c^2b+1|}{2b} - \frac{\ln|a^2b+1|}{2b}.$$

This suggests that

$$F(x) = \frac{\ln|1+bx^2|}{2b}.$$

(Since $b > 0$, we know $|1+bx^2| = 1+bx^2$.) Taking the derivative confirms this:

$$\frac{d}{dx} \left(\frac{\ln(1+bx^2)}{2b}\right) = \frac{x}{1+bx^2}.$$

CHECK YOUR UNDERSTANDING

- True, since $\int_0^2 (f(x) + g(x))dx = \int_0^2 f(x)dx + \int_0^2 g(x)dx$.
- False. It is possible that $\int_0^2 (f(x) + g(x))dx = 10$ and $\int_0^2 f(x)dx = 4$ and $\int_0^2 g(x)dx = 6$, for instance. For example, if $f(x) = 5x - 3$ and $g(x) = 3$, then $\int_0^2 (f(x) + g(x))dx = \int_0^2 5x dx = 10$, but $\int_0^2 f(x)dx = 4$ and $\int_0^2 g(x)dx = 6$.
- False. We know that $\int_0^4 f(x)dx = \int_0^2 f(x)dx + \int_2^4 f(x)dx$, but it is not true that $\int_2^4 f(x)dx$ must be the same value as $\int_0^2 f(x)dx$. For example, if $f(x) = 3x$, then $\int_0^2 f(x)dx = 6$, but $\int_2^4 f(x)dx = 24$.
- True, since $\int_0^2 2f(x)dx = 2 \int_0^2 f(x)dx$.
- False. This would be true if $h(x) = 5f(x)$. However, we cannot assume that $f(5x) = 5f(x)$, so for many functions this statement is false. For example, if f is the constant function $f(x) = 3$, then $h(x) = 3$ as well, so $\int_0^2 f(x)dx = \int_0^2 h(x)dx = 6$.
- True. If $a = b$, then $\Delta x = 0$ for any Riemann sum for f on the interval $[a, b]$, so every Riemann sum has value 0. Thus, the limit of the Riemann sums is 0.
- False. For example, let $a = -1$ and $b = 1$ and $f(x) = x$. Then the areas bounded by the graph of f and the x -axis on the two halves of the interval $[-1, 1]$ cancel with each other and make $\int_{-1}^1 f(x)dx = 0$. See Figure 5.32.

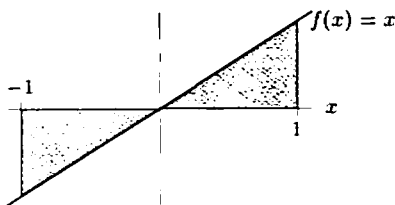

Figure 5.32

- False. Let $f(x) = 7$ and $g(x) = 9$ for all x . Then $\int_1^2 f(x)dx + \int_2^3 g(x)dx = 7 + 9 = 16$, but $\int_1^3 (f(x) + g(x))dx = \int_1^3 16dx = 32$.
- False. If the graph of f is symmetric about the y -axis, this is true, but otherwise it is usually not true. For example, if $f(x) = x + 1$ the area under the graph of f for $-1 \leq x \leq 0$ is less than the area under the graph of f for $0 \leq x \leq 1$, so $\int_{-1}^1 f(x)dx < 2 \int_0^1 f(x)dx$. See Figure 5.33.

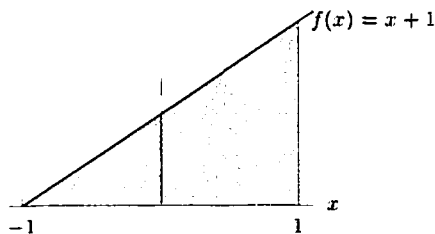

Figure 5.33

- False. Any function $f(x)$ that is negative between $x = 2$ and $x = 3$ has $\int_2^3 f(x)dx < 0$, so $\int_0^3 f(x)dx > \int_0^2 f(x)dx$.
- True. Since $\int_0^2 f(x)dx$ is a number, if we use the variable t instead of the variable x in the function f , we get the same number for the definite integral.
- False. Let $f(x) = x$ and $g(x) = 5$. Then $\int_2^6 f(x)dx = 16$ and $\int_2^6 g(x)dx = 20$, so $\int_2^6 f(x)dx \leq \int_2^6 g(x)dx$, but $f(x) > g(x)$ for $5 < x < 6$.
- True, by Theorem 5.4 on Comparison of Definite Integrals:

$$\frac{1}{b-a} \int_a^b f(x)dx \leq \frac{1}{b-a} \int_a^b g(x)dx.$$

14. True. We have

$$\begin{aligned} \text{Average value of } f \text{ on } [0, 10] &= \frac{1}{10-0} \int_0^{10} f(x) dx \\ &= \frac{1}{10} \left(\int_0^5 f(x) dx + \int_5^{10} f(x) dx \right) \\ &= \frac{1}{2} \left(\frac{1}{5} \int_0^5 f(x) dx + \frac{1}{5} \int_5^{10} f(x) dx \right) \\ &= \text{The average of the average value of } f \text{ on } [0, 5] \text{ and} \\ &\quad \text{the average value of } f \text{ on } [5, 10]. \end{aligned}$$

15. False. If the values of $f(x)$ on the interval $[c, d]$ are larger than the values of $f(x)$ in the rest of the interval $[a, b]$, then the average value of f on the interval $[c, d]$ is larger than the average value of f on the interval $[a, b]$. For example, suppose

$$f(x) = \begin{cases} 0 & x < 1 \text{ or } x > 2 \\ 1 & 1 \leq x \leq 2. \end{cases}$$

Then the average value of f on the interval $[1, 2]$ is 1, whereas the average value of f on the interval $[0, 3]$ is $(1/(3-0)) \int_0^3 f(x) dx = 1/3$.

16. True. We have by the properties of integrals in Theorem 5.3,

$$\int_1^9 f(x) dx = \int_1^4 f(x) dx + \int_4^9 f(x) dx.$$

Since $(1/(4-1)) \int_1^4 f(x) dx = A$ and $(1/(9-4)) \int_4^9 f(x) dx = B$, we have

$$\int_1^9 f(x) dx = 3A + 5B.$$

Dividing this equation through by 8, we get that the average value of f on the interval $[1, 9]$ is $(3/8)A + (5/8)B$.

17. True. By the properties of integrals in Theorem 5.3, we have:

$$\int_a^b (f(x) + g(x)) dx = \int_a^b f(x) dx + \int_a^b g(x) dx.$$

Dividing both sides of this equation through by $b-a$, we get that the average value of $f(x) + g(x)$ is average value of $f(x)$ plus the average value of $g(x)$:

$$\frac{1}{b-a} \int_a^b (f(x) + g(x)) dx = \frac{1}{b-a} \int_a^b f(x) dx + \frac{1}{b-a} \int_a^b g(x) dx.$$

18. (a) Does not follow; the statement implies that

$$\int_a^b f(x) dx + \int_a^b g(x) dx = 5 + 7 = 12,$$

but the fact that the two integrals add to 12 doesn't tell us what the integrals are individually. For example, we could have $\int_a^b f(x) dx = 10$ and $\int_a^b g(x) dx = 2$.

(b) This follows:

$$\int_a^b (f(x) + g(x)) dx = \int_a^b f(x) dx + \int_a^b g(x) dx = 7 + 7 = 14.$$

(c) This follows: rearranging the original statement by subtracting $\int_a^b g(x) dx$ from both sides gives

$$\int_a^b (f(x) + g(x)) dx - \int_a^b g(x) dx = \int_a^b f(x) dx.$$

Since $f(x) + g(x) = h(x)$, we have $f(x) = h(x) - g(x)$. Substituting for $f(x)$, we get

$$\int_a^b h(x) dx - \int_a^b g(x) dx = \int_a^b (h(x) - g(x)) dx.$$

PROJECTS FOR CHAPTER FIVE

1. (a) For Operation 1, we have the following:

(i) A plot of current use versus time is given in Figure 5.34.

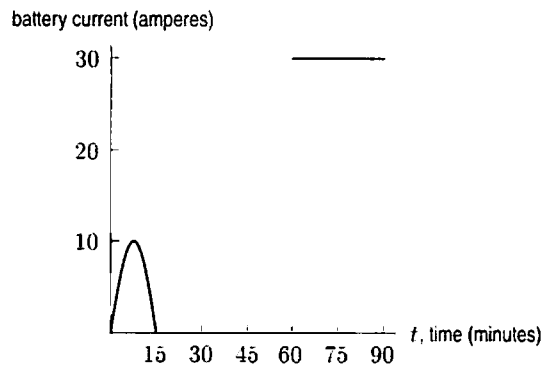

Figure 5.34: Operation 1

The battery current function is given by the formulas

$$D(t) = \begin{cases} 10 \sin \frac{2\pi t}{30} & 0 \leq t \leq 15 \\ 0 & 15 \leq t \leq 60 \\ 30 & 60 \leq t \leq 90. \end{cases}$$

(ii) The battery current function gives the rate at which the current is flowing. Thus, the total discharge is given by the integral of the battery current function:

$$\begin{aligned} \text{Total discharge} &= \int_0^{90} D(t) dt = \int_0^{15} 10 \sin \frac{2\pi t}{30} dt + \int_{15}^{60} 0 dt + \int_{60}^{90} 30 dt \\ &\approx 95.5 + 900 \\ &= 995.5 \text{ ampere-minutes} = 16.6 \text{ ampere-hours.} \end{aligned}$$

(iii) The battery can discharge up to 40% of 50 ampere-hours, which is 20 ampere-hours, without damage. Since Operation 1 can be performed with just 16.6 ampere-hours, it is safe.

(b) For Operation 2, we have the following:

(i) The total battery discharge is given by the area under the battery current curve in Figure 5.35. The area under the right-most portion of the curve, (when the satellite is shadowed by the earth), is easily calculated as 30 amps · 30 minutes = 900 ampere-minutes = 15 ampere-hours. For the other part we estimate by trapezoids, which are the average of left and right rectangles on each subinterval. Estimated values of the function are in Table 5.1.

Table 5.1 *Estimated values of the battery current*

Time	0	5	10	15	20	25	30
Current	5	16	18	12	5	12	0

Using $\Delta t = 5$, we see

$$\begin{aligned} \text{Total discharge} &= \frac{1}{2}(5 + 16) \cdot 5 + \frac{1}{2}(16 + 18) \cdot 5 + \frac{1}{2}(18 + 12) \cdot 5 \\ &\quad + \frac{1}{2}(12 + 5) \cdot 5 + \frac{1}{2}(5 + 12) \cdot 5 + \frac{1}{2}(12 + 0) \cdot 5 \\ &\approx 330 \text{ ampere-minutes} = 5.5 \text{ ampere-hours.} \end{aligned}$$

The total estimated discharge is 20.5 ampere-hours.

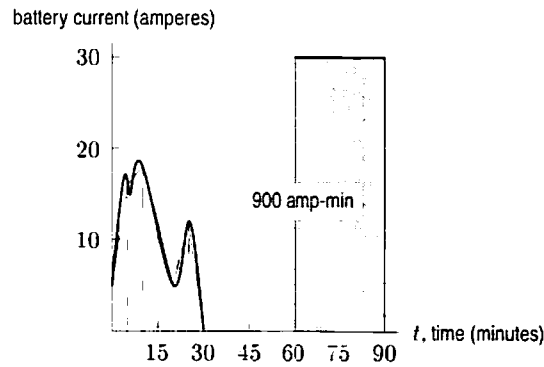

Figure 5.35: Operation 2

- (ii) Since the estimated discharge appears to be an underestimate, Operation 2 probably should not be performed.
- 2. (a) The volume of the cylindrical tank is $\pi \cdot (\frac{d}{2})^2 \cdot l$. The volume of the rectangular tank is $w \cdot d \cdot l$. Setting these two volumes equal to each other gives $w = \frac{\pi \cdot d}{4}$.
If the gas is at a depth of h in the rectangular tank, then the tank is exactly h/d full, since

$$\frac{\text{Volume left in rectangular tank}}{\text{Total volume of rectangular tank}} = \frac{w \cdot h \cdot l}{w \cdot d \cdot l} = \frac{h}{d}$$

- (b) For the same height h in the two tanks, (see Figure 5.36), the error is given by

$$\begin{aligned} \text{Error} &= \text{Fraction of cylindrical tank which is full} - \frac{h}{d} \\ &= \frac{A_1 l}{\pi(d/2)^2 l} - \frac{h\pi(d/4)l}{d\pi(d/4)l} \\ &= \frac{A_1 l}{\pi(d/2)^2 l} - \frac{A_2 l}{\pi(d^2/4)l} \\ &= \frac{A_1 - A_2}{\pi(d^2/4)} \end{aligned}$$

Since the length has canceled out, we can ignore it in calculating the error.

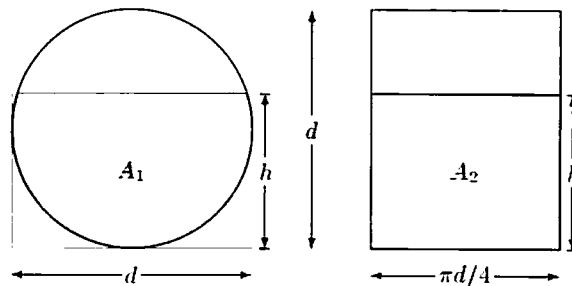

Figure 5.36

(c)

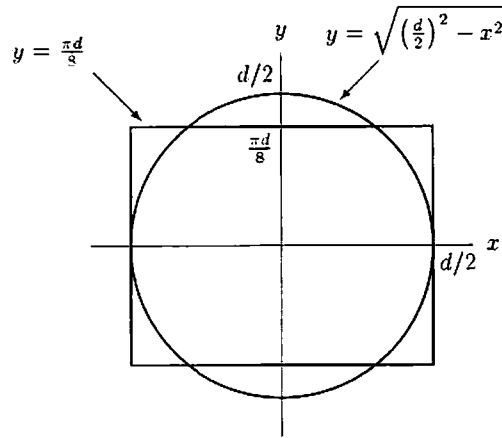

Figure 5.37

(d)

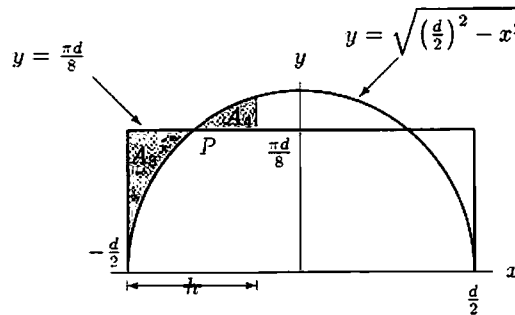

Figure 5.38

For any $0 \leq h \leq d$, Figure 5.38 shows that the error in measuring the fraction of gas remaining, assuming that the tank is rectangular rather than cylindrical, is given by

$$E(h) = 2 \cdot \frac{(A_3 - A_4) \cdot l}{\pi(d^2/4)l} = 2 \cdot \frac{\int_{-(d/2)}^{-(d/2)+h} \left(\frac{\pi d}{8} - \sqrt{\left(\frac{d}{2}\right)^2 - x^2} \right) dx}{\pi(d^2/4)}$$

- (e) The width of the rectangular tank was chosen so that its volume equals the volume of the cylindrical tank. In addition, the volume of half the rectangular tank equals half the volume of the cylindrical tank. This means that the error $E(h) = 0$ when $h = 0$, $h = d/2$, and $h = d$. Let us consider the value of $E(h)$ as h increases from 0 to $d/2$. When h is slightly above 0, the fact that the line $y = \pi d/8$ is above the circle means that $E(h)$ increases as h increases. After h passes the value corresponding to the point P in Figure 5.38, the error starts to decrease as the circle is above the line. This means the maximum value of $E(h)$ occurs where the circle and the line cross. This happens when

$$\begin{aligned} \frac{\pi d}{8} &= \sqrt{\left(\frac{d}{2}\right)^2 - x^2} \\ x &= \pm \sqrt{\frac{d^2}{4} - \frac{\pi^2 d^2}{64}} = \pm \frac{d}{8} \sqrt{16 - \pi^2} \end{aligned}$$

Thus,

$$h = \frac{d}{2} + \frac{d}{8} \sqrt{16 - \pi^2} \quad \text{or} \quad h = \frac{d}{2} - \frac{d}{8} \sqrt{16 - \pi^2}.$$