

AT MICROFICHE
REFERENCE
LIBRARY

A project of Volunteers in Asia

The Construction of a Transportable Metal Kiln

by W.D.J. Whitehead

Published by:

Tropical Research and Development Institute (TDRI)
127 Clerkenwell Road
London EC1R 5DB
ENGLAND

Available from:

same as above

Reproduced by permission.

Reproduction of this microfiche document in any form is subject to the same restrictions as those of the original document.



The construction of a transportable charcoal kiln

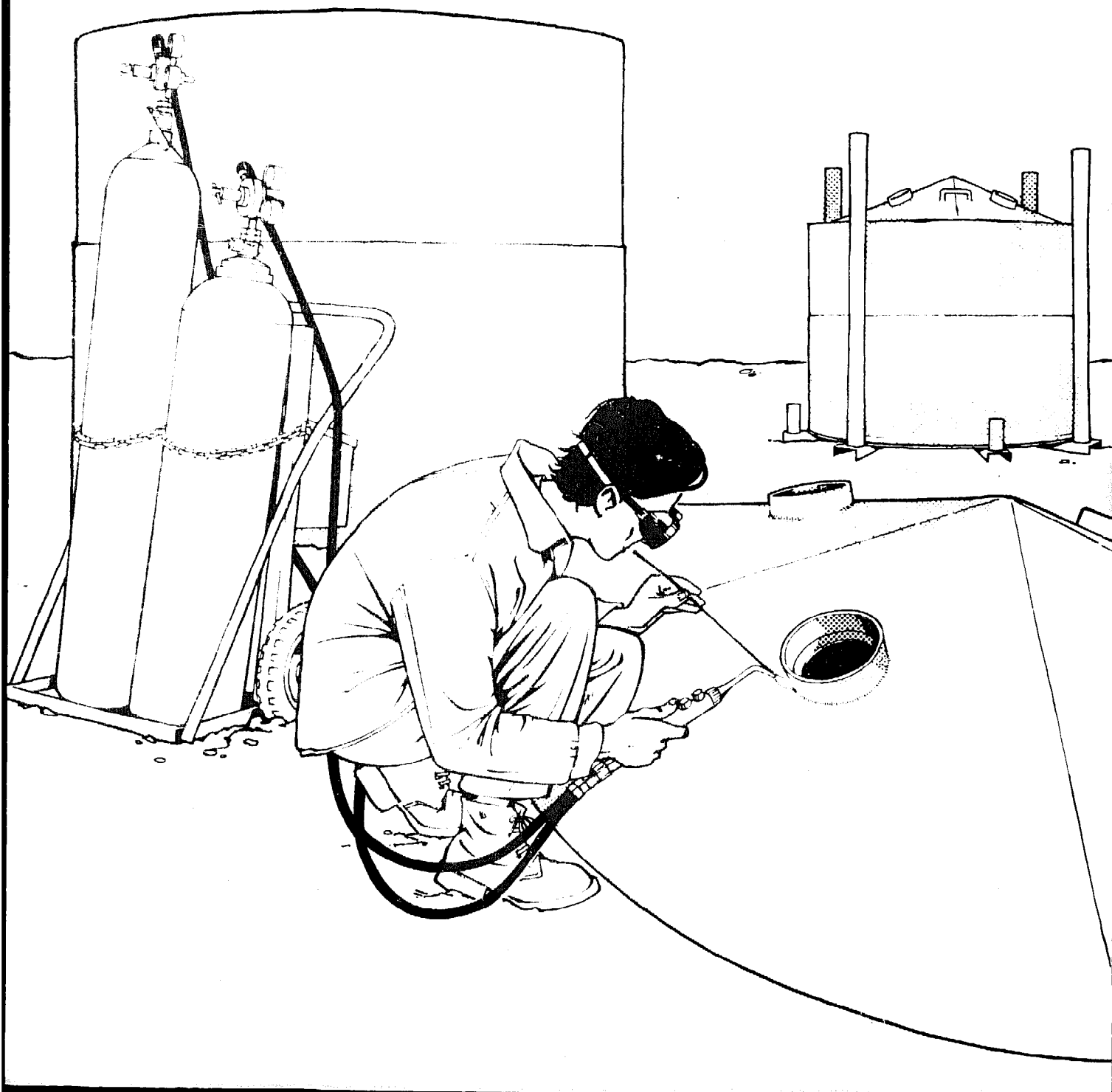

The construction of a transportable charcoal kiln

W D J Whitehead

Contents

	Page
Introduction	3
Description	3
Manufacture	4
List of materials	5
How to make the base	7
How to make the upper section	9
How to make the top cover	11
How to make the smoke stacks	13
How to make the sieve-chute	14

The Tropical Products Institute recommends that charcoal production be carried out under the guidance of a Forestry Department or similar government body, to prevent the uncontrolled exploitation of woodlands for financial gain.

The use of transportable metal kilns in charcoal production is particularly suited for local authority reforestation and land reclamation schemes.

Introduction

This guide describes how to construct a transportable charcoal kiln which will produce charcoal more quickly and efficiently than the traditional pit and earth clamp method.

The kiln is made from sheet metal and can be built in a workshop by local craftsmen with a reasonable degree of skill and experience.

The kiln has a life of 3–4 years in continuous use. Rural Technology Guide 12 describes how to operate the kiln.

Description

The kiln consists of two interlocking cylindrical sections (1, 2) and a conical cover (3). The cover has four equally-spaced steam release ports (4) which may be closed off with plugs (5) as required. The kiln is supported on eight air inlet/outlet channels (6) arranged radially round the base. During charring, four smoke stacks (7) are fitted on to alternate air channels.

Figure 1

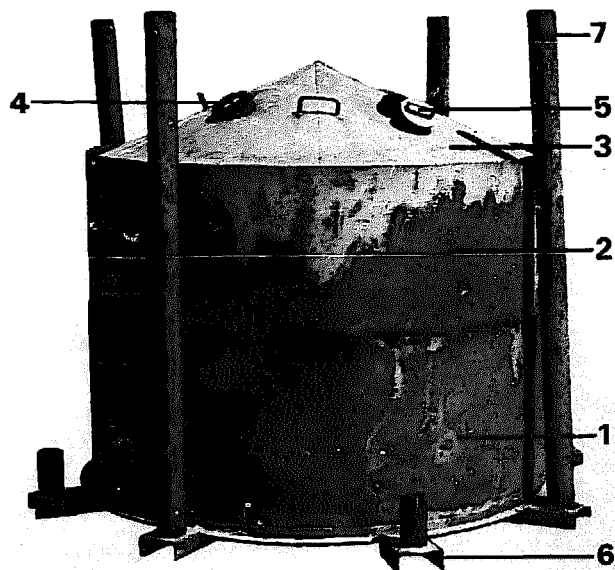

Manufacture

You will need the following tools and equipment.

1. Sheet metal-bending rolls able to take sheet at least 900 mm wide and 3 mm thick.
2. Angle-bending rolls for bending the reinforcing angles (a skilled blacksmith should be able to make these if rolls are not available).
3. Oxy-acetylene welding/cutting equipment.
4. Engineer's large vice.
5. Hand tools, e.g. hacksaw, files, hand drill and bits.
6. Clamps for holding pieces during welding.

Also desirable but not essential:

7. Guillotine or bench shear.
8. Folding machine for sheet metal up to 3 mm thick.
9. Electric arc welding equipment (This would speed up construction).

The materials required (with their metric measurements) are listed on page 5. You may use equivalent Imperial sizes of materials. The TPI cannot guarantee good results where major changes are made in the dimensions or proportions of the kiln. If you wish to make major modifications to the design please approach TPI before starting work.

Construction and assembly instructions are given in the following pages. Figure 2 is a dimensional constructional drawing. You are advised to read the instructions carefully before you start to construct the kiln.

List of Materials

	Part	Material	Quantity
Base section	Top and bottom rings	50 mm × 50 mm × 3 mm mild steel (m.s.) angle	<i>Sufficient to cut:</i> 6 pieces, each 2 430 mm long
	Body (Construction Method 1)	3 mm m.s. sheet (Note 1)	3 pieces, each 2 430 mm × 900 mm
	Body (Construction Method 2)	3 mm m.s. sheet	3 pieces each 2 480 mm × 900 mm.
Upper section	Top ring	50 mm × 50 mm × 3 mm m.s. angle	3 pieces, each 2 398 mm long
	Bottom ring	50 mm × 50 mm × 3 mm m.s. strip	3 pieces, each 2 398 mm long
	Body	2 mm m.s. sheet	3 pieces, each 2 448 mm × 900 mm
Top cover	Cover sectors	2 mm m.s. sheet	2 pieces, cut to dimensions shown in Fig. 6.
	Steam ports	50 mm × 3 mm m.s. strip	4 pieces, each 630 mm long
	Lifting handles	10 mm diameter m.s. rod (concrete reinforcing bar)	4 pieces, each 500 mm long
Steam port covers (4 per kiln)	Bodies	Either 50 mm × 3 mm m.s. strip <i>OR</i> 140 mm diameter steel pipe. (Use pipe if available)	4 pieces, each 440 mm long <i>OR</i> 4 rings, each 50 mm wide
	Top discs	3 mm m.s. sheet	4 discs, each 190 mm diameter.
	Handles	5 mm diameter steel rod (concrete reinforcing bar)	4 pieces, each 180 mm long
Base channels (8 per kiln)	Channel sections	3 mm m.s. sheet	8 pieces, each 500 mm × 500 mm
	Spigots (Note 2)	Either 3 mm m.s. sheet <i>OR</i> 120 mm diameter steel pipe	8 pieces, each 375 mm × 150 mm <i>OR</i> 8 pieces, each 150 mm long
Smoke stacks (4 per kiln)		Thin-walled steel pipe	4 pieces, each 2 300 mm long (Note 2)
		<i>OR</i> 2 mm m.s. sheet	<i>OR</i> See instructions, page 13 to calculate quantities required.

Note 1. We recommend using Corten 'A' or similar weathering steel for the sheet metal parts and to give a longer kiln life. Weathering steels contain up to 3% copper, chromium, vanadium and phosphorus. They form a durable oxide layer needing no further protection. If weathering steel is not available or if the kiln is to be stored for some time before use, paint the outside of the kiln with red oxide primer or other suitable rust inhibiting paint. Once the kiln is in use, the paint will be progressively burnt off but will give some protection against external corrosion.

Note 2. The steel pipe used for the smoke stacks should be of the thin-walled type (2–3 mm wall thickness). The sizes shown on the drawing (Figure 2) may be altered. Any diameter of pipe, from 100 mm – 150 mm can be used. The pipes must fit properly on to the spigots in the base channel (see page 13).

Figure 2

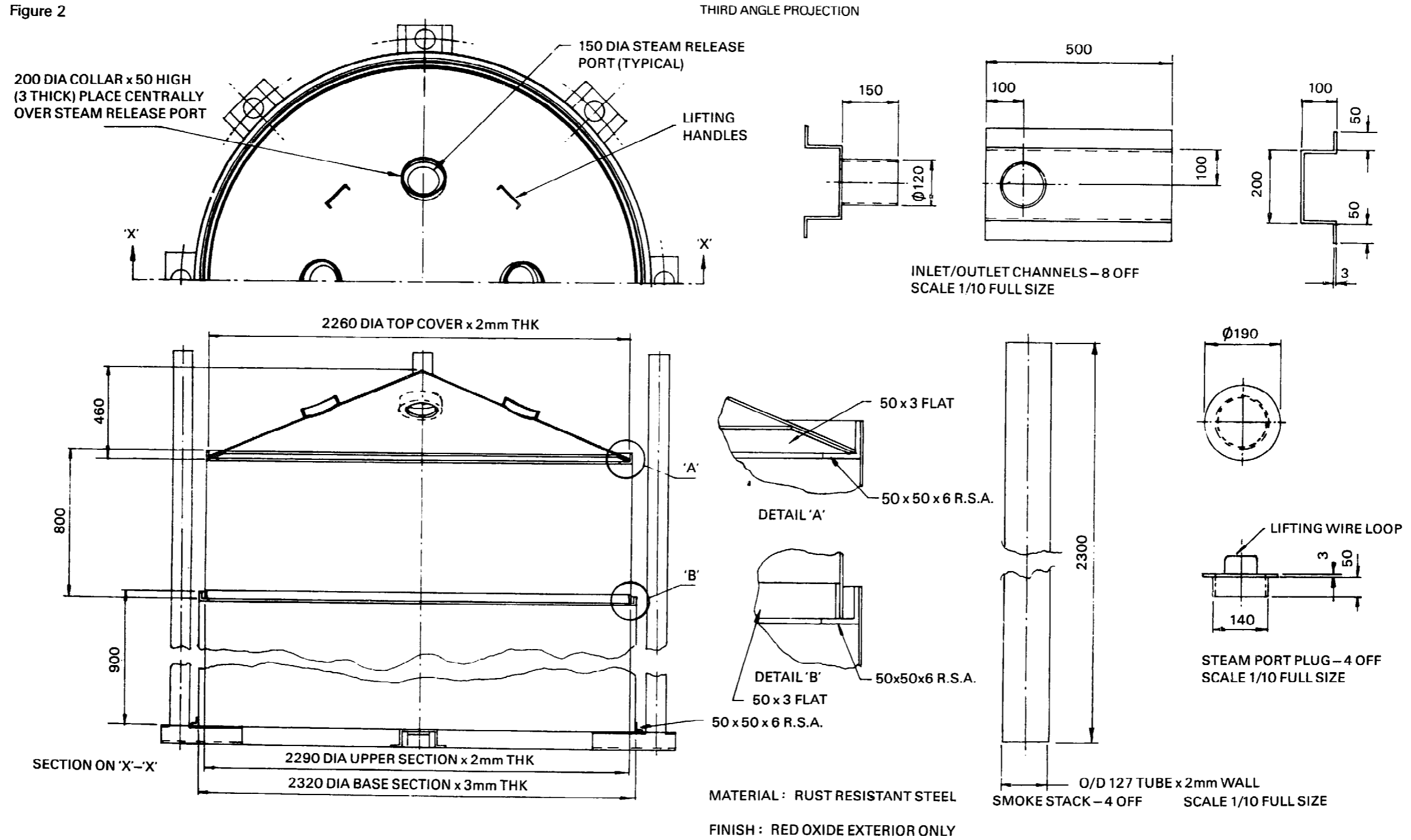

How to make the base section

Figure 3

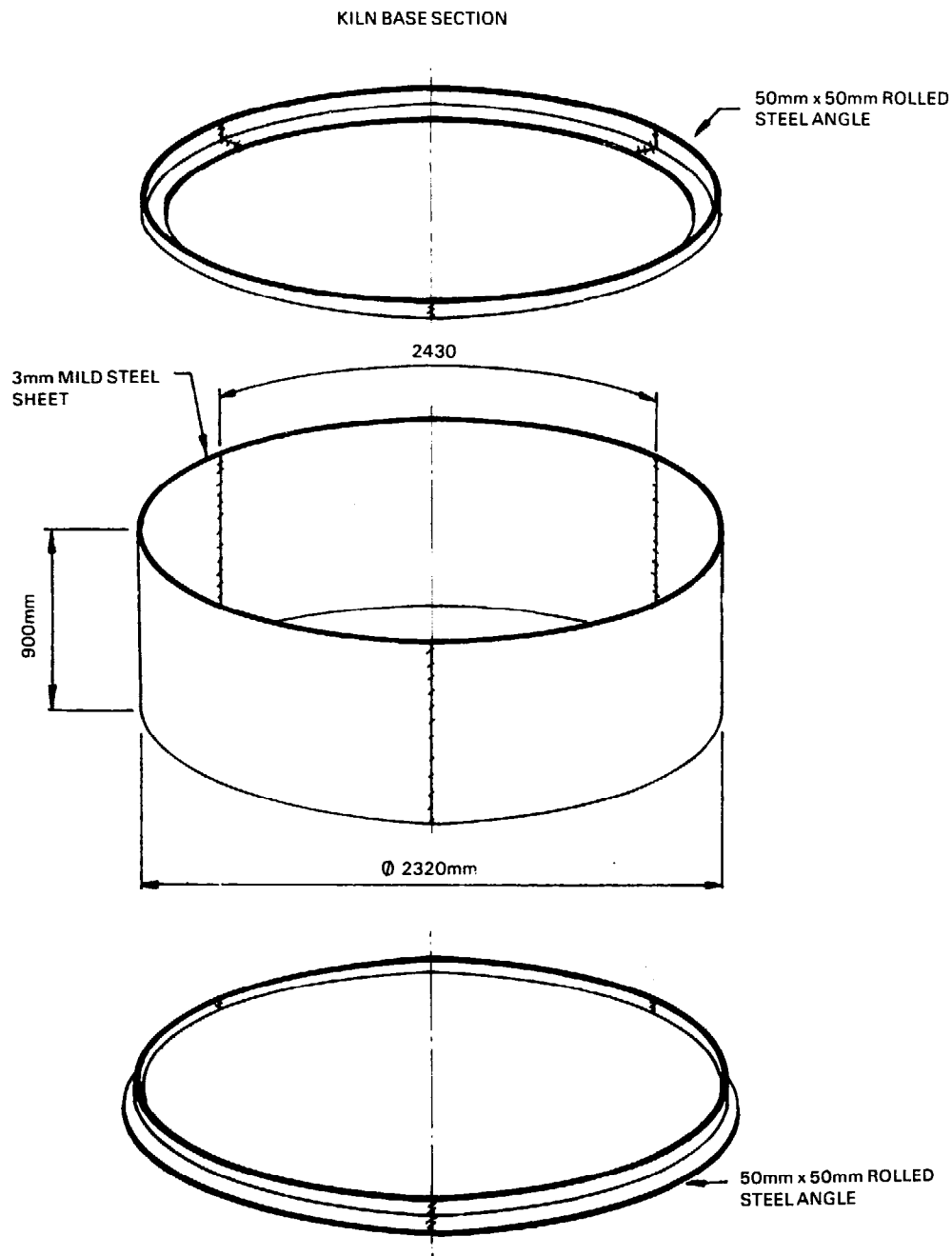

Top and bottom rings

1. Cut six 2 430 mm lengths of 50 mm × 50 mm × 3 mm m.s. angle.
2. Take three of these lengths to make the bottom ring. Bend each length, using the bending rolls, or by blacksmithing, to a radius of 1 160 mm. The vertical flange must be on the INSIDE.
3. Check that the ends fit together well – if not, trim the ends with a hacksaw.
4. Tack-weld into a ring.
5. Check that the ring rests flat on the ground – if not, break and re-weld or twist until it is satisfactory.
6. Complete the welds.
7. Take the remaining three lengths to make the top ring. Form them into a ring with the vertical flange on the OUTSIDE.
8. Make the top ring in the same way as the bottom ring.

Body (Method 1)

1. Cut three pieces of 3 mm-thick m.s. sheet, each 2 430 mm × 900 mm.
2. Remove any sharp edges.
3. Bend the pieces to a radius of 1 160 mm, using the bending rolls.
4. Tack-weld the edges of the pieces together to make a cylinder.
5. Check that the rings fit well on the cylinder and tack-weld them in place at three points round the cylinder. Note that the bottom ring fits OUTSIDE the cylinder and the top ring fits INSIDE the cylinder.
6. Check that the cylinder stands upright on the ground.
7. When satisfactory, weld the seams. The side seams should be *continuous* welds. Any gaps will allow air to get into the kiln.
8. Weld the rings. In this case, several welds spaced round the cylinder will be adequate, as any gaps will be sealed with earth or sand when the kiln is in use.

Body (Method 2)

For ease of welding this alternative method can be used

1. Cut three pieces of 3 mm-thick m.s. sheet, each 2 480 × 900 m.
2. Remove any sharp edges.
3. Bend the pieces to a radius of 1 160 mm, using the bending rolls.
4. Tack-weld the pieces to make a cylinder. The extra length of each piece gives an overlap of 50 mm at each joint.
5. Fit the bottom ring OUTSIDE the cylinder, the top ring INSIDE the cylinder.
6. Check that the cylinder stands upright on the ground.
7. Weld the side joints, inside and out. The outside welds should be continuous to prevent air getting into the kiln. The inside weld may be intermittent. It is easier to weld an overlap than to weld two plates which butt together and this method also gives an allowance for errors.
8. Weld the rings finally into position as before.

How to make the upper section

Figure 4

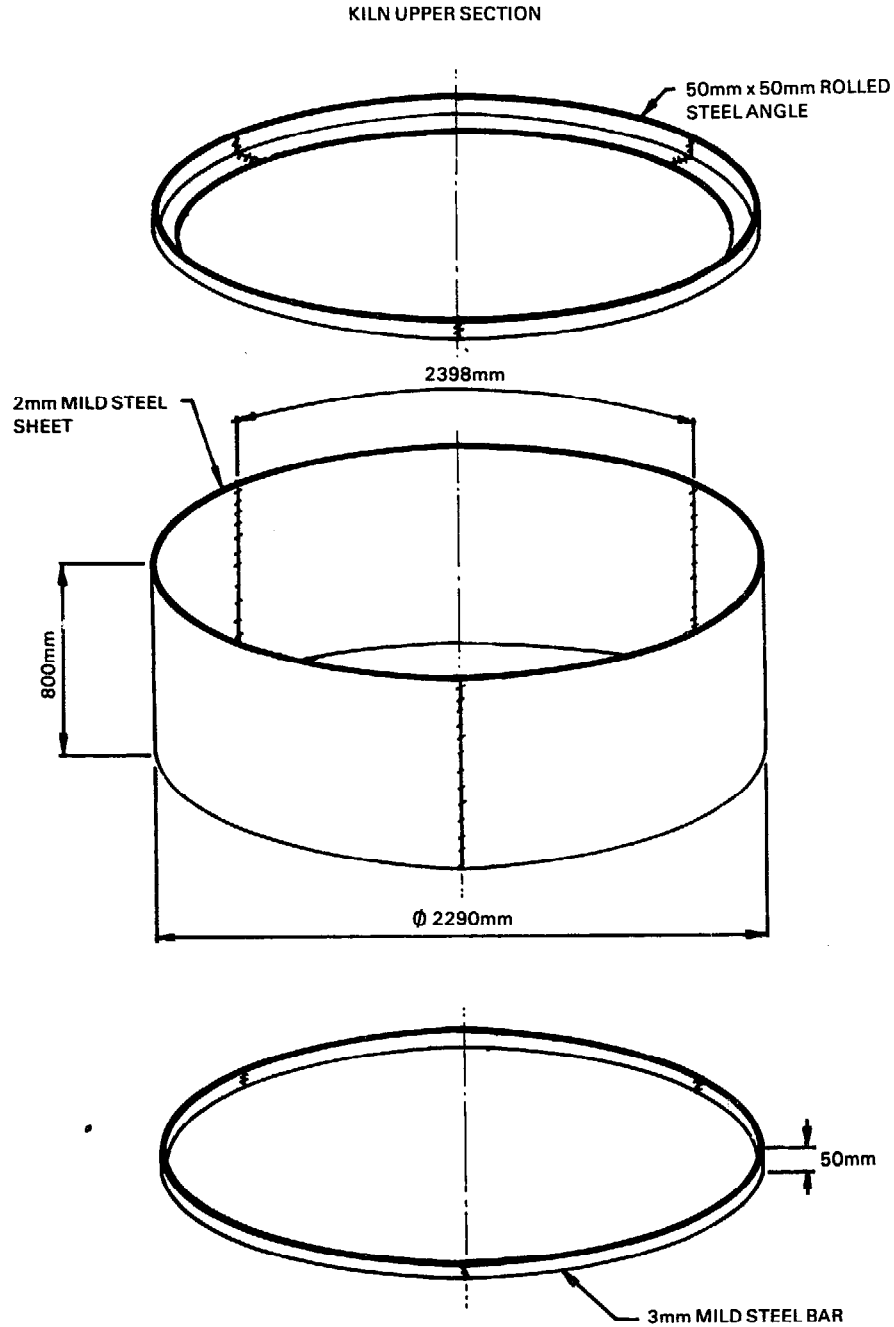

Top and bottom rings

1. Cut six 2 398 mm lengths of 50 mm × 3 mm m.s. strip.
2. Take three of these lengths to make the bottom ring. Bend each length to a radius of 1 145 mm.
3. Tack-weld the lengths together to form a ring.
4. Lay the ring flat on the ground to check that it is true.
5. Complete the welds.
6. Take the remaining three lengths to make the top ring.
7. Bend to a radius of 1 145 mm with the vertical flange OUTSIDE.
8. Weld into a ring as described above.

Body

1. Cut three pieces of 2 mm m.s. sheet, each 2 448 mm long × 800 mm wide.
2. Bend to a radius of 1 145 mm.
3. Make up into a cylinder as described for the base section (Body: Method 2) Note that the flat ring is welded INSIDE at BOTTOM; the angled ring is welded INSIDE at TOP.
4. Make sure at the tack-welding stage that the cylinder fits on to the base section correctly.

How to make the top cover

Figure 5

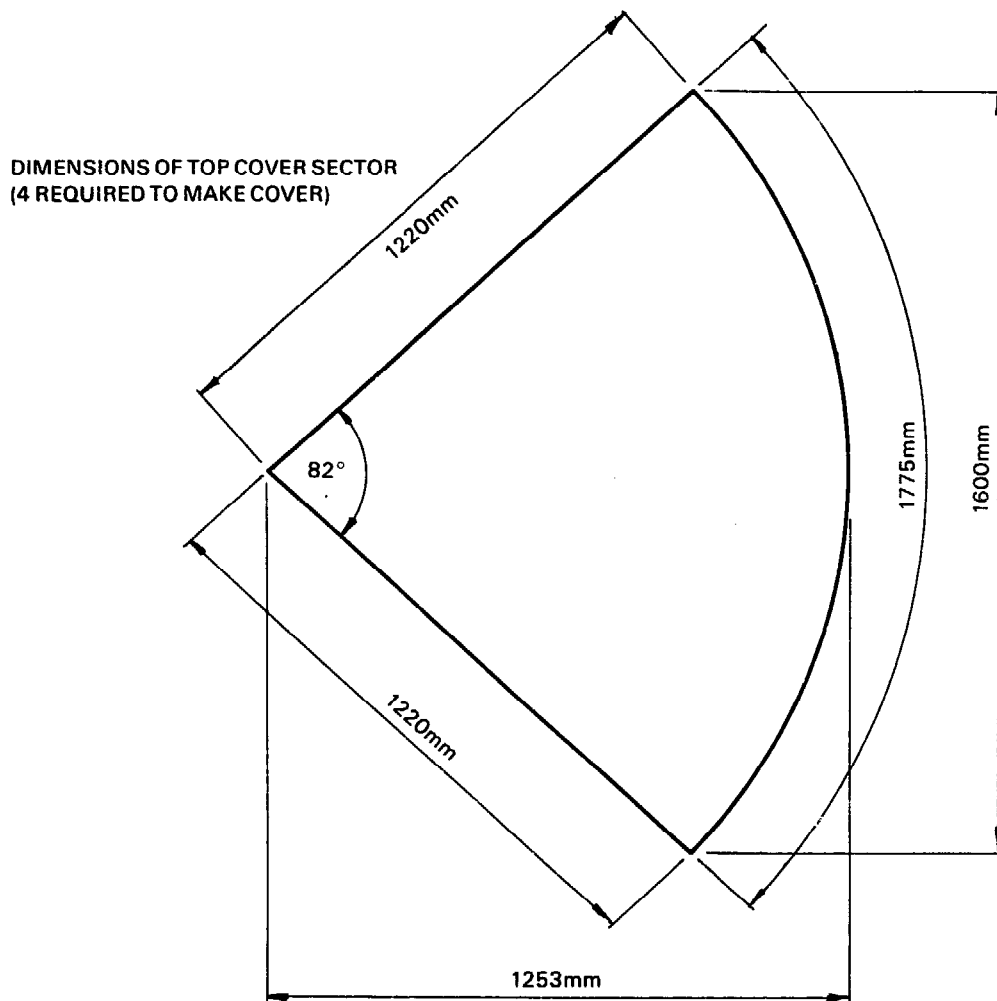
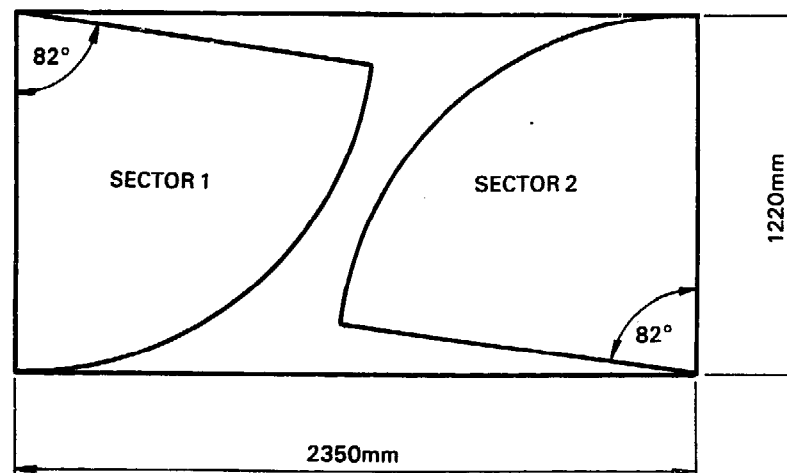

Figure 6

CUTTING TWO SECTORS FROM
STANDARD SIZED SHEET METAL



1. Mark out four sector shaped pieces of 2 mm m.s. sheet to the dimensions shown in Figure 5. Two pieces can be cut from one sheet as shown in Figure 6.

2. Cut out sectors, remove any sharp edges.
3. Mark out and cut out a 150 mm-diameter hole in each sector for the steam release port.

LOCATION OF STIFFENING STRIP

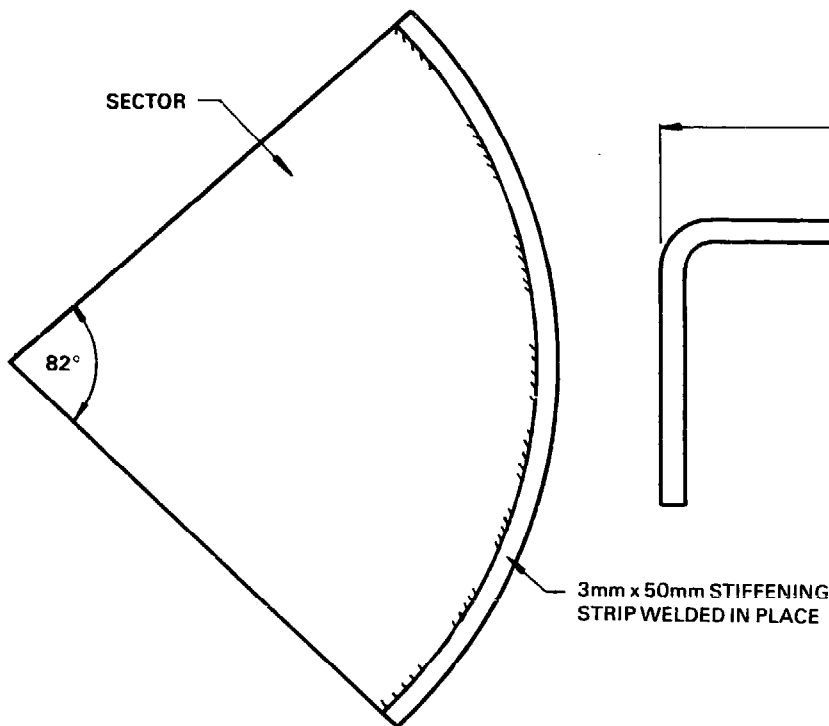

Figure 7

DIMENSIONS OF LIFTING HANDLES FOR TOP SECTIONS

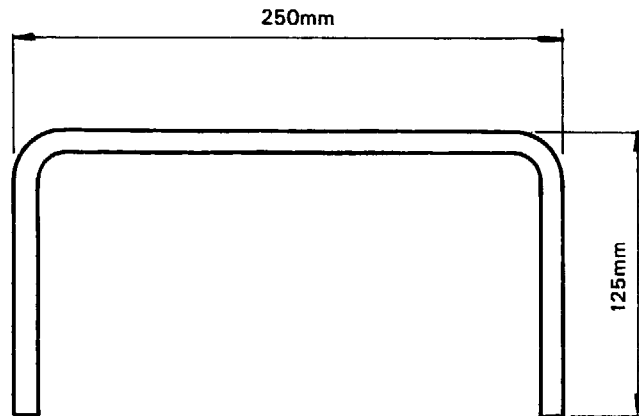

Figure 8

4. Cut four 1 775 mm lengths of 50 mm x 3 mm m.s. strip. Bend to the radius of the bottom of each sector. Weld in place, as in Figure 7.
5. Bend the sectors so that when placed together they form a cone.
6. Tack-weld together.
7. Make sure that the cone sits correctly on the upper section. Break and re-weld if necessary.
8. Weld the joints—the seams between the sectors must be continuous welds.

Steam ports (4 required)

1. Cut four 630 mm lengths of 50 mm x 3 mm m.s. strip.
2. Roll into 200 mm-diameter rings.
3. Weld the seams.
4. Weld the rings in place centrally over the steam port holes in top cover.

Lifting handles (4 required)

1. Cut four 500 mm lengths of 10 mm dia. rod.
2. Bend as in Figure 8.
3. Mark four positions equally spaced around the cone, about 250 mm in from the edge.
4. Weld the handles into place in the positions marked. Use plenty of weld metal.

Steam port covers (4 required)

1. Cut four 50 mm wide rings from a length of 140 mm dia. steel pipe. If pipe is not available cut four 440 mm lengths of 50 mm x 3 mm strip. Bend into 140 mm dia. rings and weld the seams.
2. Cut four 190 mm dia. discs from 3 mm m.s. strip.
3. Weld discs on to the rings.
4. Cut four handles from 5 mm dia. rod and weld one on to each disc, as in the drawing (Figure 2).

How to make the smoke stacks

Base channels (8 required)

1. Cut eight pieces of 3 mm m.s. sheet, each measuring 500 mm × 500 mm.
2. Bend and fold up as in the drawing (Figure 2) into channels. If no folding machine is available the bending can be done in a bench vice. Mark the bend lines on the metal and make each bend in several stages. Do not try to form each bend to 90° in one attempt.
3. To make the spigots cut eight 150 mm lengths of 120 mm dia. steel pipe. OR cut eight pieces of 3 mm mild steel, each measuring 375 mm × 150 mm and roll up into tubes of about 120 mm diameter. Make sure they are all as nearly as possible of the same diameter.
4. On each channel, mark the centre of a hole 100 mm from one end.
5. Carefully cut out the holes until they are the same size as the inside diameter of the spigots.
6. Weld the spigots into position over the holes. Make sure they are upright.

Smoke stacks (4 required)

These stacks must fit over the spigots in the base channels. They must not be a tight fit. Otherwise, when the kiln is in use and hot, they may be impossible to remove. However, they should not be too loose either.

1. Simply cut four 2 300 mm lengths, if suitably sized steel pipe is available.
2. If no pipe is available, make the stacks from sheet metal. They can be made in one piece if a large set of bending rolls (2 300 mm wide) is available. Otherwise, make the stacks in several sections and join together.
3. Divide the length of the stack (approx. 2 300 mm) into the smallest number of equal lengths which can be formed to the bending rolls available. Add about 50 mm to each length to give some overlap for assembling the stack sections.

Check that this dimension will still fit between the rolls, i.e. for 900 mm wide rolls, three lengths of 770 mm will give a stack height of 2 310 mm. Adding on assembly allowance of 50 mm gives: $770 + 50 = 820$ mm section length.

4. Cut the required number of pieces from 2 mm m.s. sheet.

5. Form into tubes. These tubes should be of slightly different diameters so that the top section is smallest and fits tightly into the section below, which in turn will fit tightly into the next section down, and so on. The bottom section should fit well, but not tightly, on to the spigots in the base channels. Make sure that all the stacks will fit all the channels, so that the stacks can be easily changed round when the kiln is in use.

6. Assemble the tube sections, pushing each section about 50 mm into the section below.

Make sure that the assembled stack is reasonably straight and will stand upright on the channel sections.

7. Weld the stacks together but do *NOT* weld the stacks on to the channels.

How to make the sieve-chute (for use when unloading the kiln)

Two types of sieve chute can be made. The basic type stands inside the kiln base section (see Figure 9). The free-standing type uses the same body but has hinged legs (Figure 10).

Figure 9



Figure 10

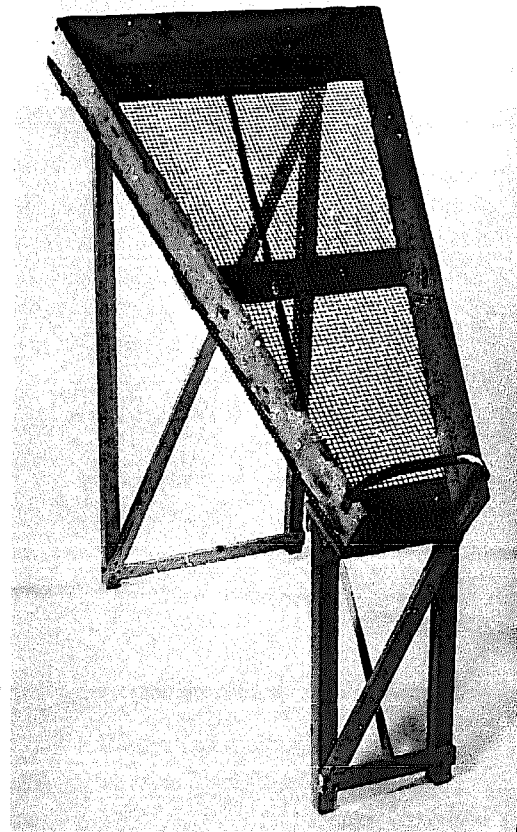

List of materials for making sieve-chutes

	Material	Quantity
Sieve body	19 mm × 150 mm sawn board	{ 2 pieces, each 1 500 mm long 2 pieces each 900 mm long 1 piece each 400 mm long
	19 mm × 50 mm section timber	1 piece 600 mm long
	10 mm square wire mesh	Cut from 1 500 × 1 000 mm piece
	Wire, or steel case band	Make to fit the sacks in use.
	Wood screws	
Basic sieve (struts)	50 mm × 25 mm timber	2 pieces, each 500 mm long
Free-standing sieve (legs)	75 mm × 25 mm timber	1 piece 330 mm long
	50 mm × 50 mm timber	{ 2 pieces, each 1 600 mm long 2 pieces, each 750 mm long 1 piece, 500 mm long
	50 mm × 25 mm timber	{ 1 piece, 1 800 mm long 1 piece, 1 300 mm long 1 piece 800 mm long 3 pieces, each 650 mm long
	Hinges (2 pairs)	
	Woodscrews	

Figure 11

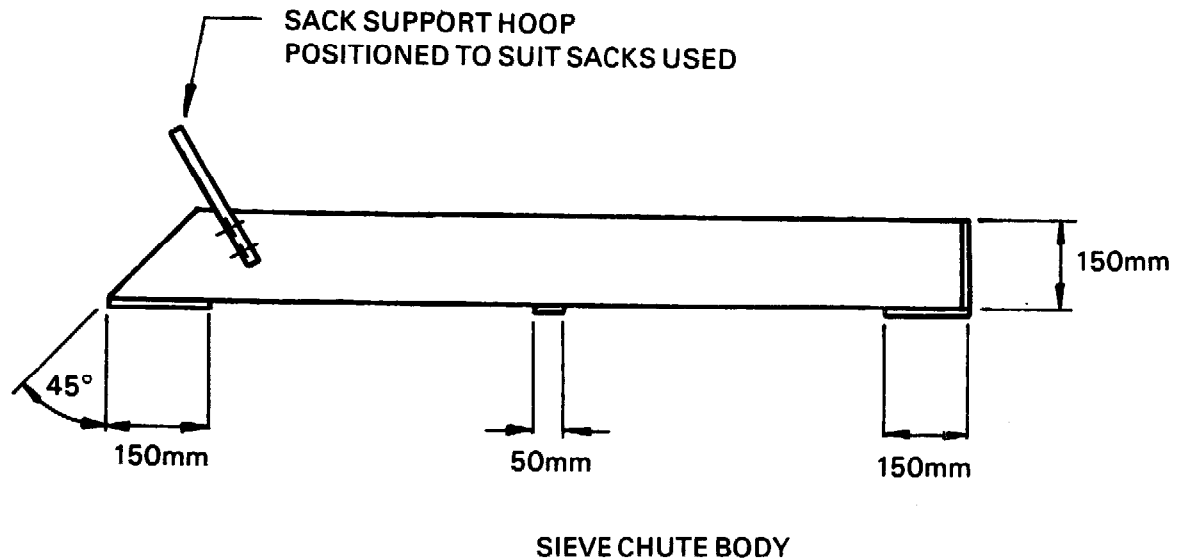
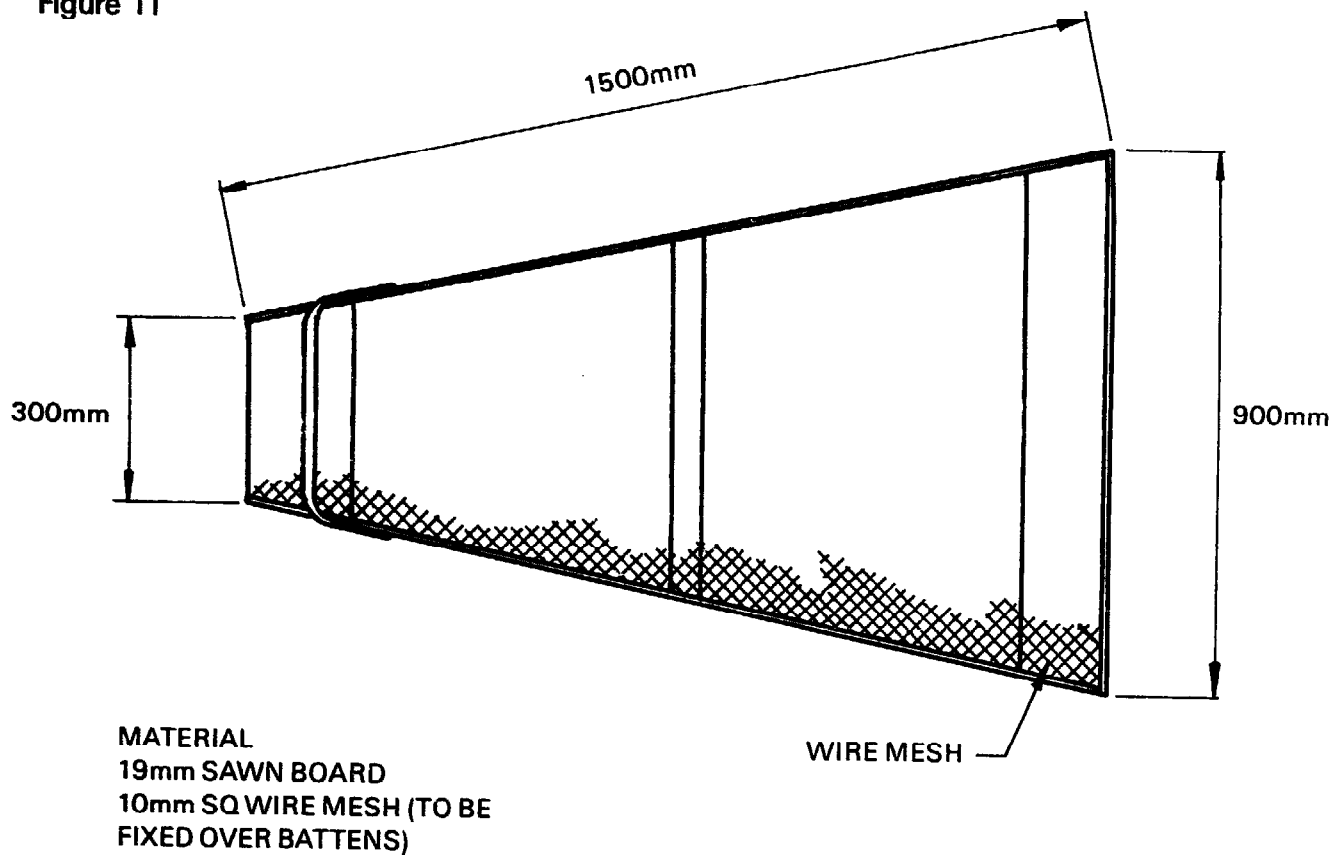

Sieve body (Figure 11)

1. Make the body from the 19 mm sawn board to the sizes shown in Figure 11. Use screws for all the joints.
2. Fit the wire mesh on top of the battens and under the sides.
3. Make a loop from stout wire or from a length of the steel band used to fasten packing cases and attach it to the front of the sieve. The loop holds the mouth of the sack open for filling so make it to fit the sacks in use.

Figure 12

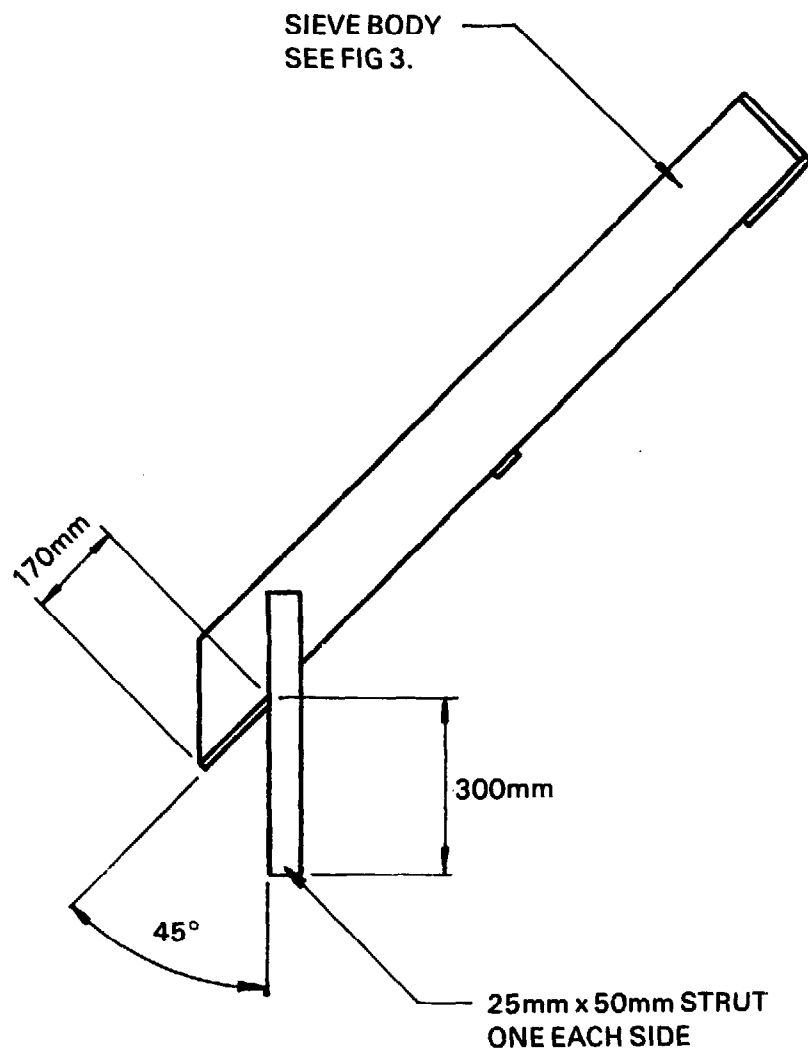

Basic sieve (Figure 12)

1. Make the two struts from 50 mm × 25 mm timber.
2. Screw them to the front of the sieve body as shown. They locate the sieve on the edge of the kiln base section.
3. Use a length of wood or a pole to hold up the back of the sieve at the correct angle. (see Figure 9).

Figure 13

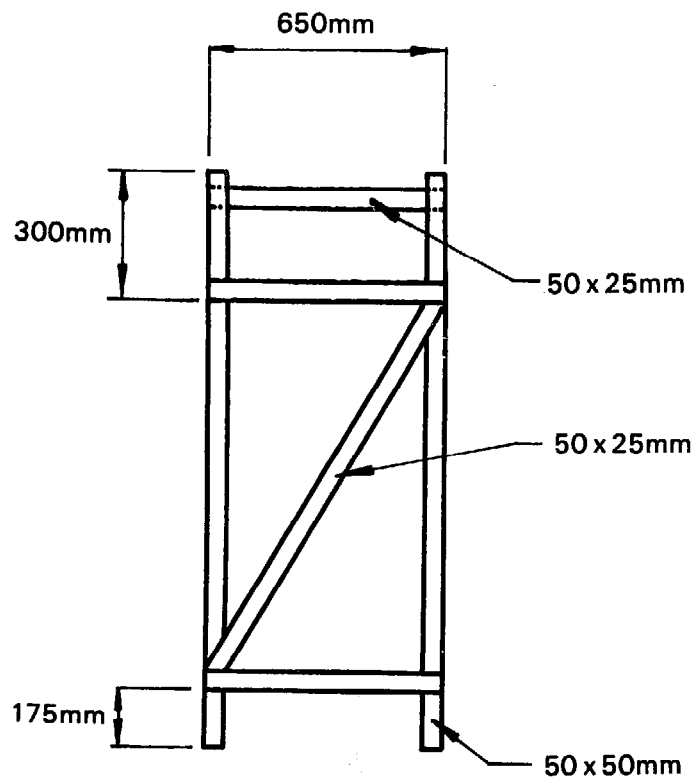
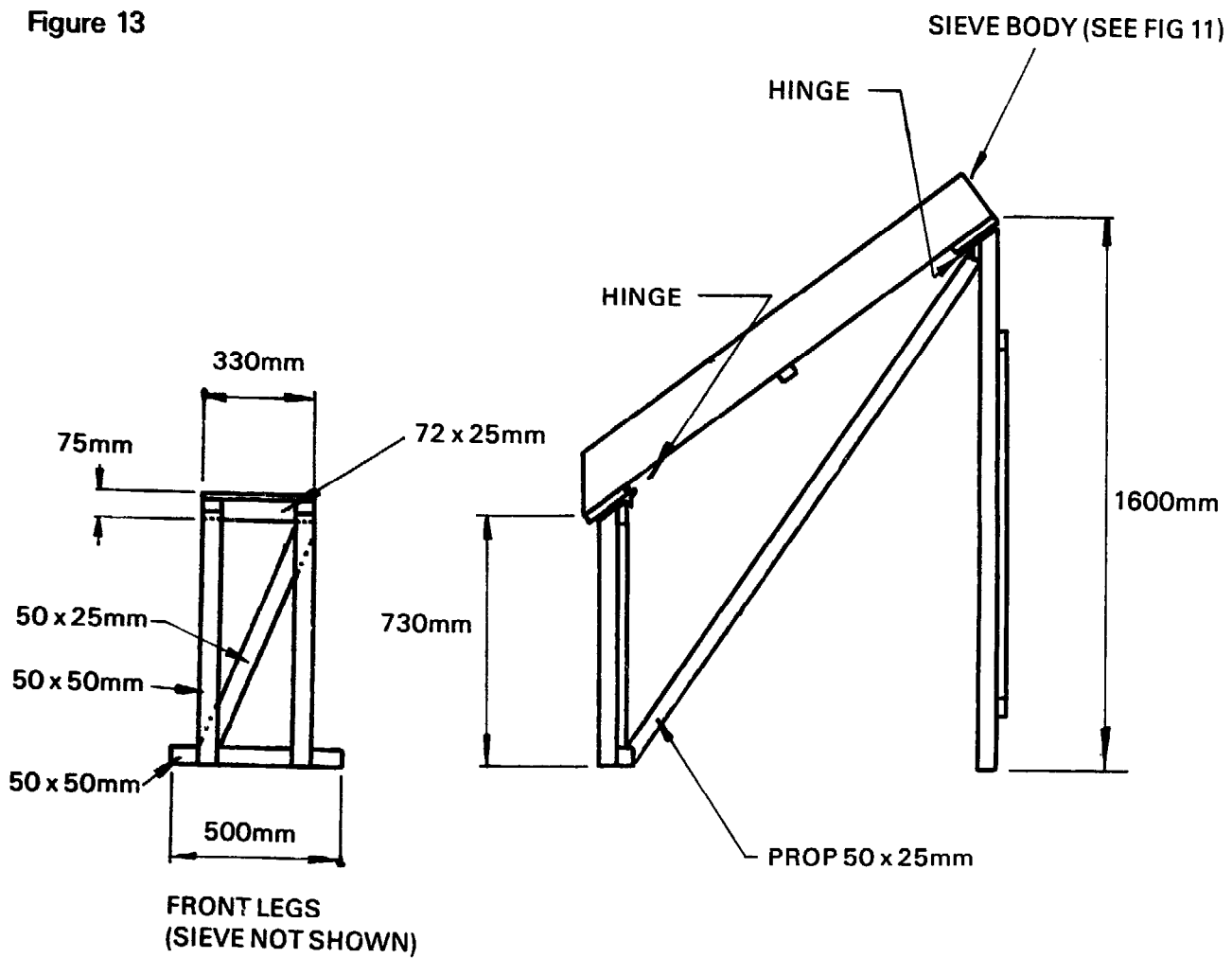

Free-standing sieve

1. Make up the legs to the sizes shown in Figure 13. Use screws for the joints.

Figure 14

1) MARK & CUT OUT FLAPS FROM THIN SHEET METAL

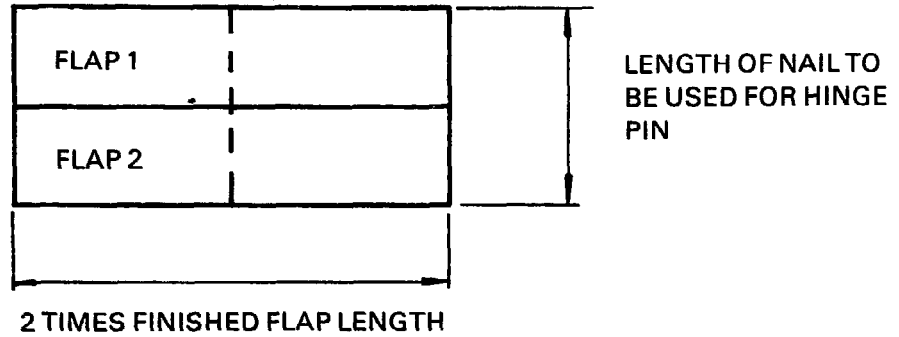

2) MAKE UP FLAP BY FOLDING AROUND NAIL

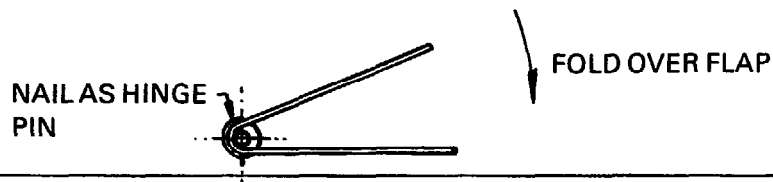

3) CRIMP FLAP TIGHT AROUND THE PIN



4) MAKE FLAP FIXING HOLES

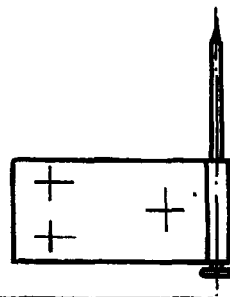

5) ASSEMBLE FINISHED FLAPS ON TO PIN

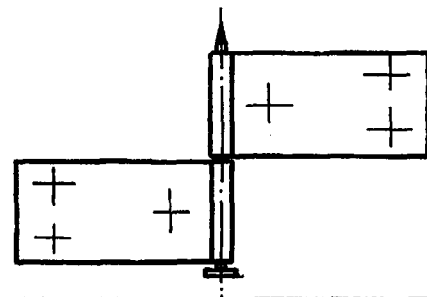

6) MAKE UP SECOND HINGE IN THE SAME WAY: - FIT ONTO WOOD SO THAT PINS MUST BE REMOVED TO BREAK THE JOINT

* SIMPLE HINGE CONSTRUCTION

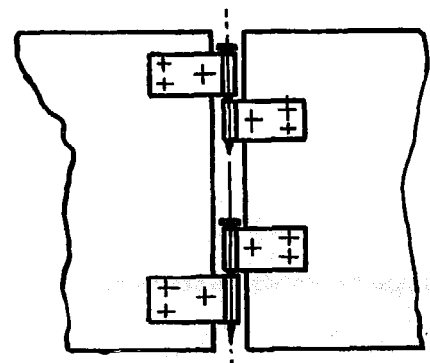

Simple hinges can be made as shown in Figure 14.

Use thin sheet metal for the flaps and a large nail for the hinge pin. Alternatively, a strip of strong canvas or leather can be used as a hinge.

Copyright and Reproduction Rights

The copyright of publications in this series belongs to the British Government and is © *Crown Copyright* 1980.

If it is intended to reproduce this guide, or any part of it, for commercial purposes, such as sale, at a profit or advertising, permission must be obtained in advance from:

The Head
Publications, Publicity and Public Relations
Section
Tropical Products Institute
56/62 Gray's Inn Road
London WC1X 8LU

Otherwise, the guide, or any part of it, may be reproduced (in English or in translation) provided it includes an acknowledgement on the following lines: —

Whitehead W D J (1980) The construction of a transportable charcoal kiln. *Rural Technology Guide, Tropical Products Institute* No 13, 20 pp. Price £1.30, including packing and postage.

No charge is made for single copies of this publication sent to governmental and educational establishments, research institutions and non-profit making organisations working in countries eligible for British Aid. Free copies cannot normally be addressed to individuals by name but only under their official titles.

Future Guides

The Institute would be glad to receive suggestions for new devices and techniques which might usefully be described in future publications in this series.

Tropical Products Institute

ISBN 0 85954 127 4
ISSN 0141 898X

The Tropical Products Institute

The Tropical Products Institute is a British Government organisation which co-operates with developing countries in helping them to derive greater benefit from their plant and animal resources. It specialises in problems which arise after harvest and is ready to provide information and advice on these problems if requests are addressed to:

The Director
Tropical Products Institute
56/62 Gray's Inn Road
London WC1X 8LU

Rural Technology Guides

The purpose of this series of Tropical Products Institute publications is to provide working details of devices or techniques suitable for use in rural communities. Each guide is fully illustrated and written in simple, practical language rather than in complex scientific terms, so that the reader can assess its usefulness and then, if he wishes, make the device or carry out the technique described.

The guides are intended principally for extension workers, instructors and other field staff in rural development. However, it is hoped that they will also be useful to anyone who is interested and can follow the pictures and instructions.

The series is being published in English and each publication will, therefore, be useful only in areas where the English language is widely used. For other areas, it is suggested that the text might usefully be translated into the local language and reproduced locally. It may also be possible to prepare visual aids from the pictures in the guide, for the use of instructors and other field staff.

The Institute will be pleased to give advice to anyone intending to reprint this guide or to make visual aids from the illustrations. Requests for such advice should be sent, with full details, to the Head, Publications, Publicity and Public Relations Section, Tropical Products Institute, at the above address.