

AT MICROFICHE
REFERENCE
LIBRARY

A project of Volunteers in Asia

Syllabus for Irrigation with Windmills: Technical
Aspects

by Willem Nijhoff

Published by:

Stichting TOOL
Entrepotdok 68A/69A
1018 AD Amsterdam
THE NETHERLANDS

Available from:

same as above

Reproduced by permission.

Reproduction of this microfiche document in any
form is subject to the same restrictions as those
of the original document.

SYLLABUS FOR IRRIGATION WITH WINDMILLS
TECHNICAL ASPECTS

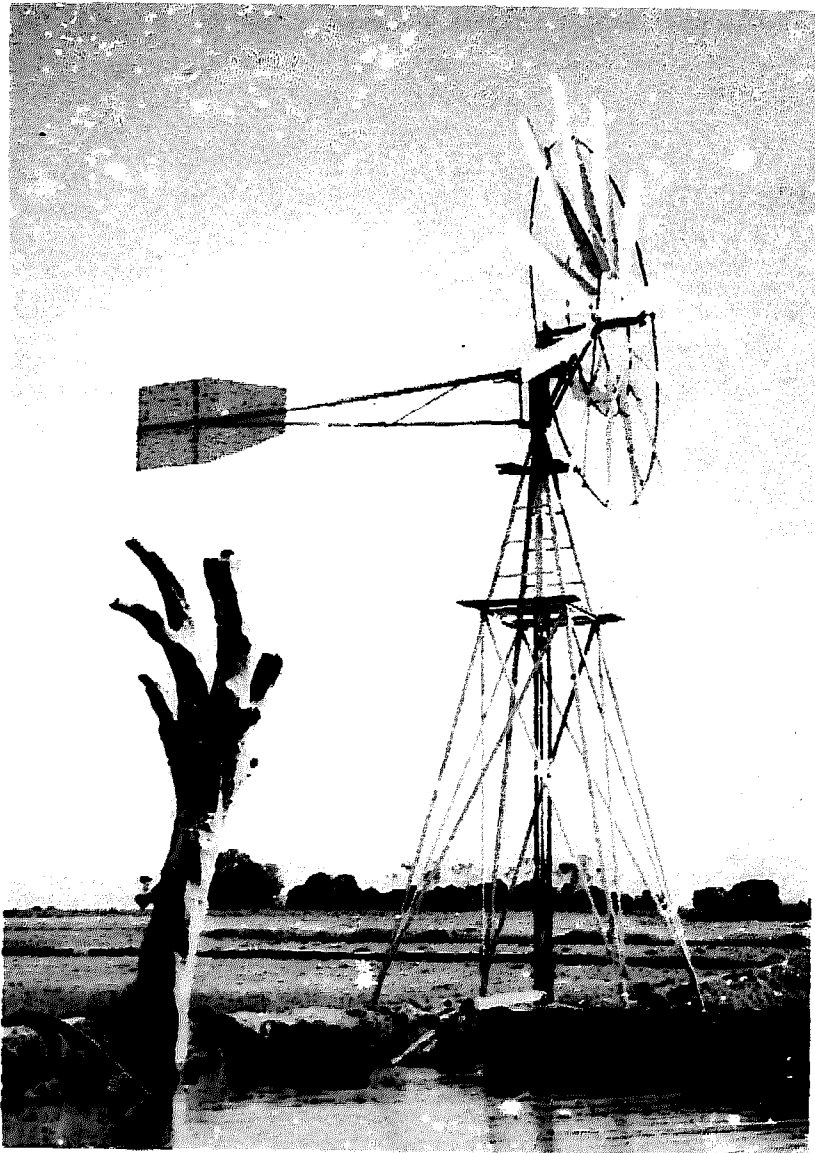

12 PU 500 windmill

By: Willem Nijhoff.

January 1982

**SYLLABUS FOR IRRIGATION WITH WINDMILLS
TECHNICAL ASPECTS**

By: Willem Nijhoff

January 1982

TOOL TECHNICAL DEVELOPMENT WITH DEVELOPING COUNTRIES
MAURITSKADE 61 a, 1092 AD AMSTERDAM, THE NETHERLANDS

WOT WORKING GROUP ON DEVELOPMENT TECHNIQUES
T.H. TWENTE, VRIJHOF 152, P.O. BOX 217,
7500 AE ENSCHEDE, THE NETHERLANDS

WINDING DISTRICT

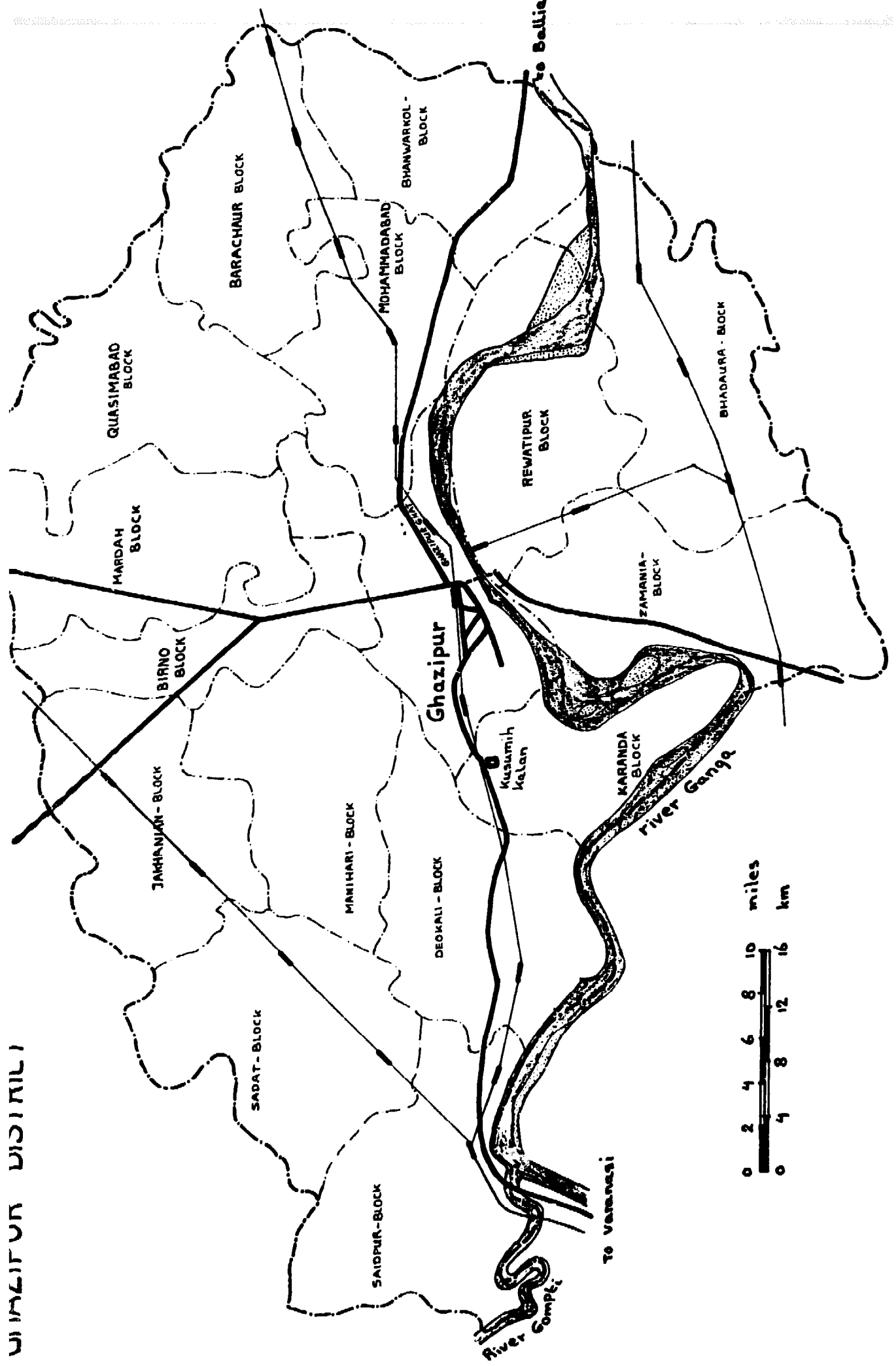

Acknowledgement

The Netherlands assistance in the windmill projects in Ghazipur and Allahabad officially stopped at the end of March 1981. It was recognized by the project management committee that the experiences of the experts in these projects should be recorded.

Finally it was agreed that the financing of this activity took place through the Steering Committee Windenergy Developing countries (SWD). This is a government financed organization promoting the interest for wind energy in developing countries and aims at helping governments, institutions and private parties in the Third World with their efforts to utilize wind energy.

The author is very grateful to all parties concerned that the experiences could be materialized in this publication. It is hoped that it will contribute to the extension of development in many countries

Willem Nijhoff

TOOL is a Dutch foundation participating in the global process of renewable development and application of socially appropriate technologies.

The broad objective is to promote greater freedom for groups which are deprived of full opportunities for local, self-programmed and self-sustained development.

The strategy is to provide and support information resource links among the practitioners, users and generators of appropriate technology for development.

The operations of TOOL are designed to match need and resource:

- technical advice and support
- research and development
- publications
- documentation systems and services
- application projects
- education and training
- organisational linkages.

WOT is a non-profit organisation at the Twente University of Technology and gives technical advice in the field of wind energy, solar energy and water supply. The broad objective is to improve the position of the weaker sections in society and the advice should be appropriate to the local situations and circumstances. To support the technical advice the WOT has a testing field where various designs are being developed and tested. The WOT is mainly a voluntary organisation and consists mainly of students of the university. Several staffmembers take care for the administrative and technical support.

CONTENTS

	page
1. Introduction	1
2. Windenergy	3
2.1 Available windpower	3
3. Airfoils	4
3.1 The relations between the velocity at the rotorblade and the forces acting on the blade	4
4. Windmill characteristics	8
4.1 Torque and power characteristics	8
4.2 Power coefficient	11
4.3 Basic form of a windmill characteristic	13
4.4 Maximum power	14
5. Design of a windmill rotor	20
5.1 Calculation of blade chords and blade setting	20
5.2 Deviation from the calculated chords and blade setting	25
5.3 Calculation of the radius of the curve of the blade	29
5.4 Measurements of the blade	30
6. Design and strength aspects of the windmill	31
6.1 Strength calculations	31
6.1.1 Strength calculations of the rotor of the 12 PU 500 windmill	31
6.1.2 Strength calculations of the tower	32
6.1.3 Bearings	39
6.2 Flywheel energy of the rotor	42
6.3 Tower height	44
7. Wind analyses	46
7.1 Availability of data	46
7.2 Reliability of the data	46
7.3 Annual wind pattern	48
7.4 Diurnal wind pattern	48
7.5 Maximum wind speed	48
7.6 Wind speed frequency distribution	48
7.7 Determining the design wind speed	53

8.	Windmill output calculations	57
8.1	Correction factor for difference in height	59
9.	Determining pump diameter	62
10.	Measuring of windmill pump performance	65
10.1	Momentaneous measuring method	66
10.2	Contineous measuring method	72
References		73
Appendix I		74
Appendix II		75

1. Introduction.

This publication has been compiled as the result of three courses given at the TOOL-ORP windmill project in Ghazipur. Those courses lasted from 10 to 8 weeks and they were a combination of theoretical aspects and practical training in the design, construction and installation of the 12 PU 500 windmill.

Another part of the courses was the implementation of the windmills with irrigation aspects, economical aspects and social aspects. This "agricultural" part, however, is not included in this publication, but is published separately by TOOL/SWD and has been compiled by A.E.M. van Vilsteren (SWD 81-4).

This publication aims at practical applications such as analyzing windregimes, determining rotor diameters, calculating bladeshapes, construction aspects of the windmill, pump choice, matching pump to windmill etc. etc. It is mainly aggravated to the 12 PU 500 windmill.

2. WINDENERGY

2.1 Available windpower

Wind is air in motion. If air with a mass m is moving with velocity v , it has kinetic energy expressed by:

$$E = \frac{1}{2} mv^2 \quad [J] \quad (2.1)$$

If the density of the air is ρ , then the kinetic energy per volume of air is:

$$E_v = \frac{1}{2} \rho v^2 \quad [J/m^3] \quad (2.2)$$

For an area A perpendicular to the wind direction the flow per second through A is:

$$\phi_v = v \cdot A \quad [m^3/s] \quad (2.3)$$

So the power that flows with the air, through area A , is the product of the kinetic energy of the air and the air-flow:

$$P = \frac{1}{2} \rho v^2 \times v \cdot A = \frac{1}{2} \rho v^3 A \quad [W] \quad (2.4)$$

This is the power available in the wind. Only part of this power can actually be extracted by a windmill.

The above derived relation for the power in the wind shows clearly that:

- The power is proportional to the density ρ .
This factor cannot be influenced and varies slightly with the height and temperature. (For 20°C at sea level $\rho = 1.2 \text{ kg/m}^3$.)
- The power is proportional to the area swept by the rotor and thus to R^2 . Radius R is chosen in the design.
- The power varies with the cube of the wind velocity v .
Note that the power increases eightfold if the wind speed doubles.

Part of the kinetic energy of the airflow is carried over to the blades of a wind rotor resulting in mechanical power.

3. AIRFOILS

3.1 The relations between the velocity at the rotor blade and the forces acting on the blade.

The rotor of a windmill consists of one or more blades attached to a hub. The cross sections of these blades can have several forms; we call these cross sections air foils. An air foil is a surface over which air flows. This flow results in two forces: LIFT and DRAG.

Roughly, lift is the force needed to bend the flow.

Lift is always perpendicular to the airflow.

Drag is measured parallel to the flow.

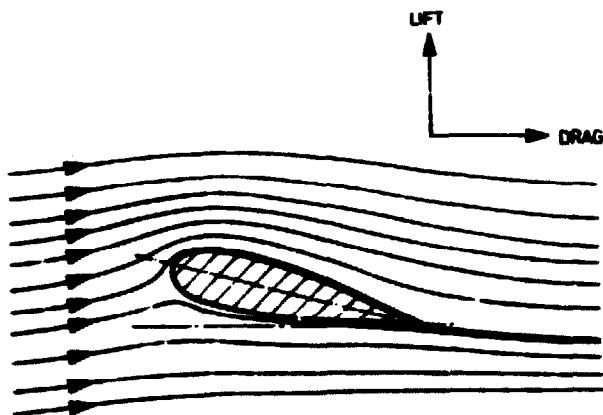

Lift and Drag

All air foils require some angle with the air flow in order to produce lift. The more lift required, the larger the angle (till a certain extent).

The chord line connects the leading edge and the trailing edge of the airfoil. The angle required for lift is called angle of attack. The angle of attack is measured between the chord line and the direction of the airflow.

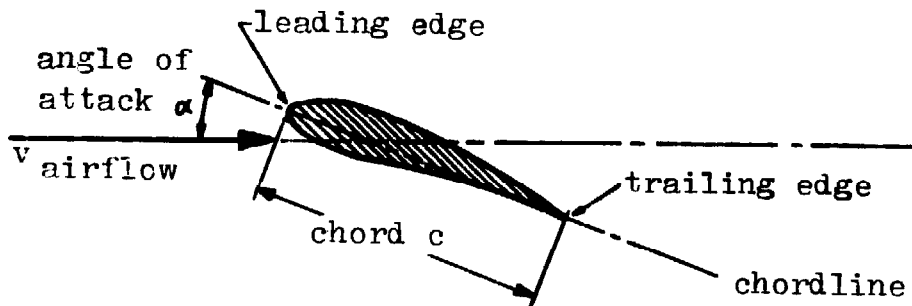

To describe the performance of an airfoil independent of size and airflow velocity, we divide lift L and drag D by $\frac{1}{2}\rho v^2 A$ where

$$\begin{aligned} \rho &= \text{air density} \quad [\text{kg/m}^3] \\ v &= \text{flow velocity} \quad [\text{m/s}] \\ A &= \text{blade area} \quad (= \text{chord} \times \text{blade length}) \quad [\text{m}^2] \end{aligned}$$

The results of these divisions are called lift coefficient C_l and drag coefficient C_d

$$C_l = \frac{L}{\frac{1}{2}\rho v^2 A} \quad (2.5)$$

$$C_d = \frac{D}{\frac{1}{2}\rho v^2 A} \quad (2.6)$$

As stated before, the amount of lift and drag that is produced, depends on the angle of attack.

This dependence is a given characteristic of an airfoil and is always presented in C_l - α and C_l - C_d graphs.

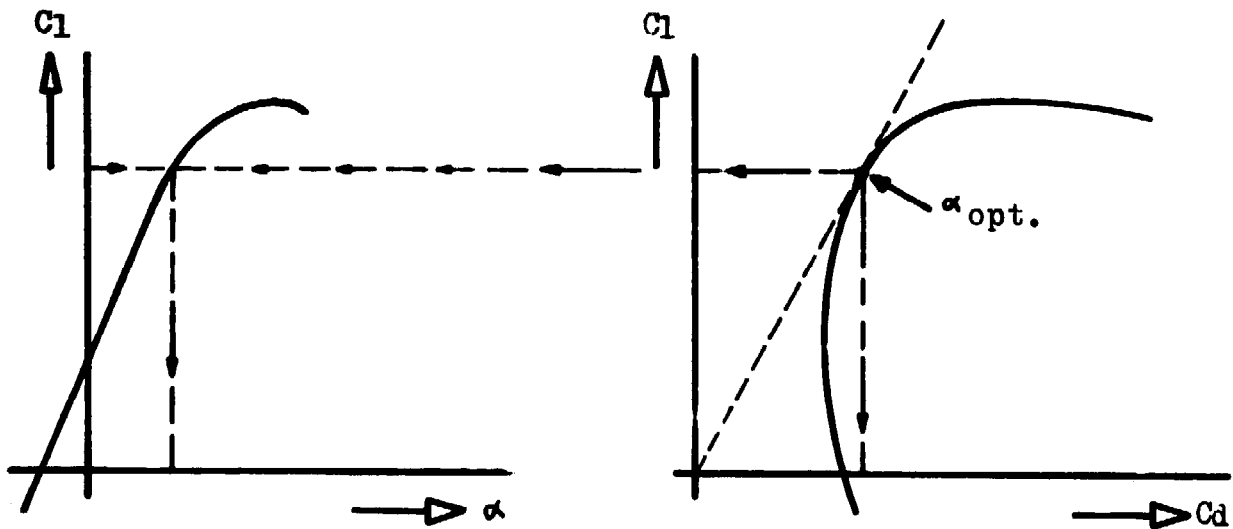





Lift and drag characteristics

The C_d/C_l - ratio is chosen as small as possible in order to optimize the rotor design.

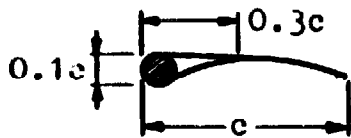
For the design of a windmill the C_l and α values have to be found that correspond with a minimum C_d/C_l - ratio.

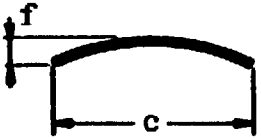
The following table gives these design values for some air foils.

Airfoil name	geometrical description	(C_d/C_l) min	α	C_l	
Sail and pole		0.1	5	0.8	
Flat steel plate		0.1	4	0.4	
Arched steel plate	 $f/c=0.07$ $f/c=0.1$	0.02 0.02	4 3	0.9 1.25	
Arched steel plate with tube on concave side	 $d < 0.1 c$	$f/c=0.07$ $f/c=0.1$	0.05 0.05	5 4	0.9 1.1
Arched steel plate with tube on convex side		$f/c=0.1$	0.2	14	1.25

A blade element of a windmill rotor "sees" a relative velocity that results from the wind velocity in combination with the velocity with which the blade element moves itself.

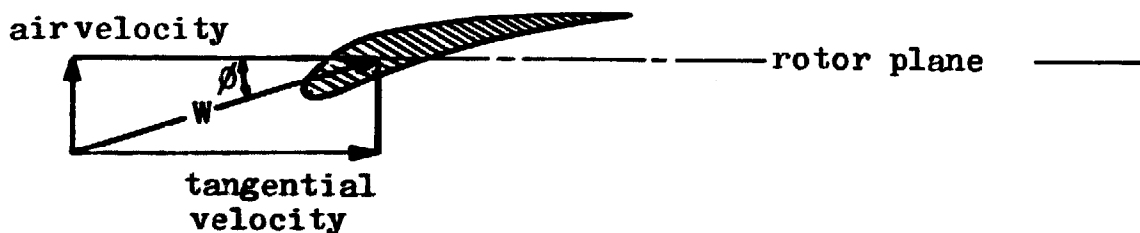

Relative velocity on rotor blade.

ϕ is the angle between the relative velocity W and the rotor plane.

4. WINDMILL CHARACTERISTICS

4.1 Torque and power characteristics.

The components in the plane of rotation of the lift forces result in a force working in tangential direction at some distance from the rotor center. This force is diminished by the component of the drag in tangential direction. The result of these two components is a propelling force in tangential direction at some distance from the rotor center.

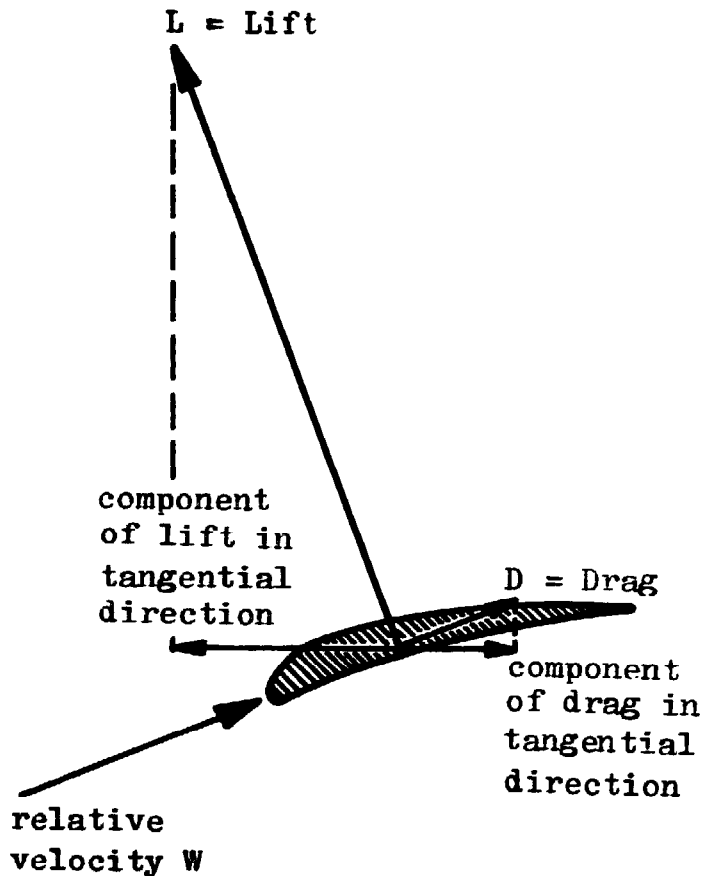

The product of this propelling force and its corresponding distance to the rotor center is the contribution of the blade element under consideration to the torque T of the rotor. The rotor rotates at an angular speed:

$$\Omega = 2\pi n \quad [\text{rad/s}] \quad (4.1)$$

The power that such a rotor extracts from the wind is transformed into mechanical power. This power is equal to the product of the torque and the angular speed.

$$T = \text{torque} \quad [\text{nm}]$$

$$\Omega = \text{angular speed} \quad [\text{rad/s}]$$

$$P = T \Omega \quad [\text{W}] \quad (4.2)$$

A windmill of given dimension transforms kinetic energy from the wind into a certain amount of power. Equation (4.2) clearly shows that a windmill for a high torque load (for example a

piston pump) will have a low angular speed; a high speed design will only produce a small amount of torque (for example for a centrifugal pump or an electricity generator).

We call a graph that shows the dependence of the windmill torque on the angular speed, a windmill torque characteristic. The following figures show the torque characteristics of two different windmills designed for the same power, but for different angular speeds. The windmill torque characteristic depends on wind speed v so we have many curves in one characteristic.

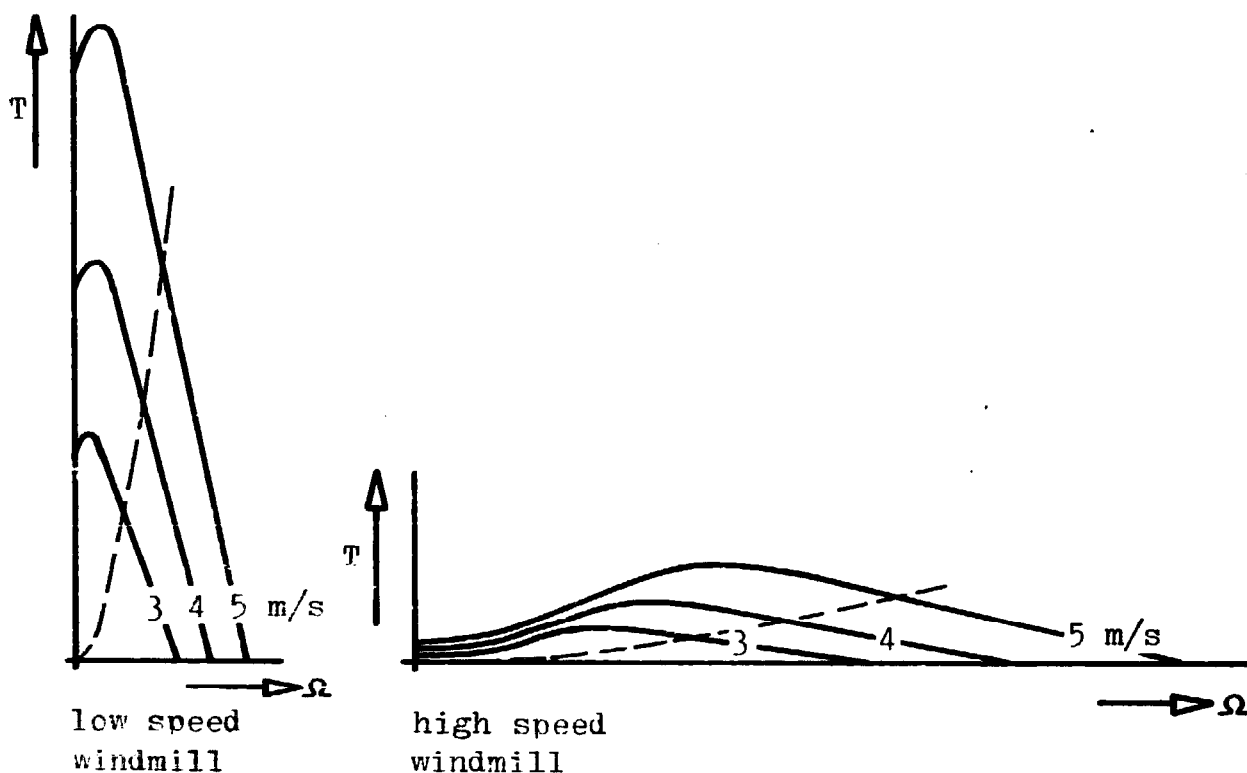

With relation (4.2) it is very simple to derive from the torque characteristics the corresponding power characteristics. See following figure, where the power-angular speed curve, belonging to windmills of the above figure are shown.

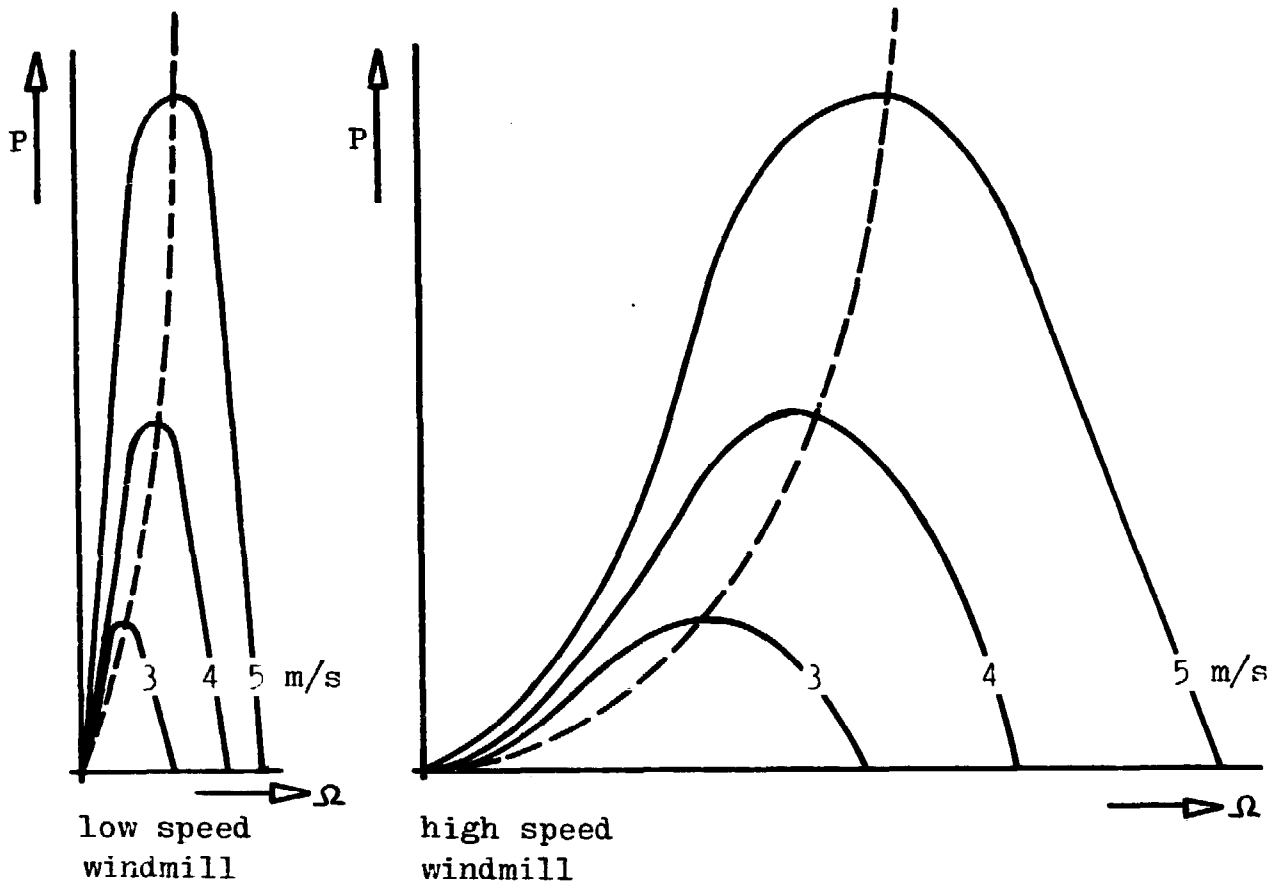

- Note 1. The power of the two windmills is the same, but it is delivered at different angular speeds.
2. The maximum power is delivered at a higher angular speed than the maximum torque.
3. The maximum of the power curves vary with the cube of the angular speed:

$$P_{\max} \sim \Omega^3 \quad (4.3)$$

while the corresponding torque values vary with the square of the angular speed:

$$T \text{ (at } P = P_{\max} \text{)} \sim \Omega^2 \quad (4.4)$$

4. The starting torque, i.e. the torque at zero revolutions per second, is considerably lower for high speed than for low speed windmills.

4.2 Power coefficient

In order to be able to compare the properties and characteristics of different windmill design under different wind conditions we write the mechanical power as the power in the air multiplied by a factor C_p

$$P_{\text{mech}} = C_p \times P_{\text{air}}$$

C_p is called power coefficient and is a measure for the success we have in extracting power from the wind. With relation (2.4) we may write:

$$C_p = \frac{P_{\text{mech}}}{\frac{1}{2} \rho V^3 \pi R^2} \quad (4.5)$$

For the same reason we divide the speed u of the rotor at radius r by the windspeed v .

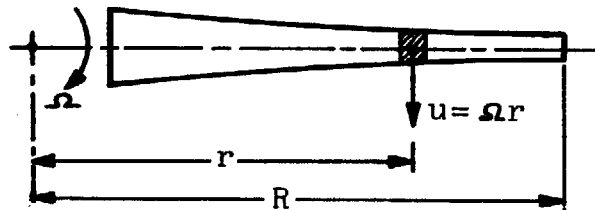

Definition of speed ratio

We call the result local speed ratio which is noted

$$\lambda_r = \frac{u}{v} = \frac{\Omega \cdot r}{v} \quad (4.6)$$

The speed ratio of the element of the rotor blade at radius R is called tip-speed ratio:

$$\lambda = \frac{\Omega \cdot R}{v} \quad (4.7)$$

Note: later it will be shown that a windmill has one value of λ at which the power coefficient is maximum. This is often called 'the tip-speed ratio of a windmill' or 'the speed ratio (Lambda) of a windmill'.

From relation (4.2) we know that

$$T = \frac{P}{\Omega} \quad (4.9)$$

With this relation we define a dimensionless torque coefficient in the following way:

$$P = C_p \frac{1}{2} \rho v^3 \pi R^2 \quad (4.5)$$

$$\Omega = \frac{v}{R} \quad (4.7)$$

$$T = \frac{P}{\Omega} \quad (4.9)$$

$$\frac{C_p}{\lambda} = \frac{T}{\frac{1}{2} \rho v^2 \pi R^3}$$

We define:

$$C_T = \frac{T}{\frac{1}{2} \rho v^2 \pi R^3} \quad (4.10)$$

Note that in this way relation (4.4) is still valid, but now in dimensionless form:

$$C_p = C_T \cdot \lambda \quad (4.11)$$

An empirical formula to derive the starting torque coefficient of a rotor as a function of its optimum tip speed ratio is:

$$C_{T \text{ start}} = \frac{0.5}{\lambda_d^2}$$

λ_d = design tipspeed ratio

4.3 Basic form of a windmill characteristic

The power coefficient C_p in equation (4.5) is not an efficiency, but may be interpreted as a measure of the success that a windmill has in transforming wind energy into mechanical energy. For one specific windmill C_p varies with tip-speed ratio of the windmill. In dimension-less form this is shown in a so-called $C_p - \lambda$ characteristic based on formulas (4.5) and (4.7).

See fig. below where one curve now represents all the curves for different v of a certain windmill.

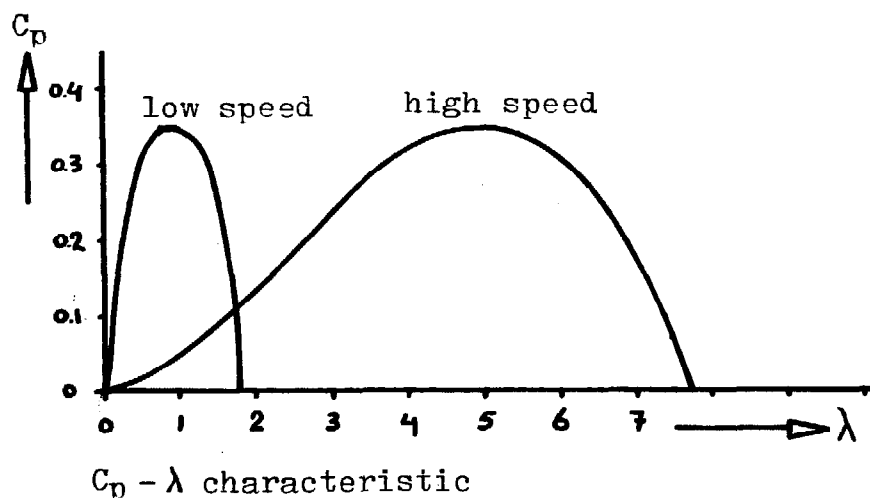

This characteristic is independent of air density ρ , windspeed v and radius R .

Using relation (4.11) we may derive from the above fig. a dimensionless form of the torque-speed characteristic of the windmill: $C_T - \lambda$ curve; see next fig.

Also here one curve represents all curves of a certain windmill.

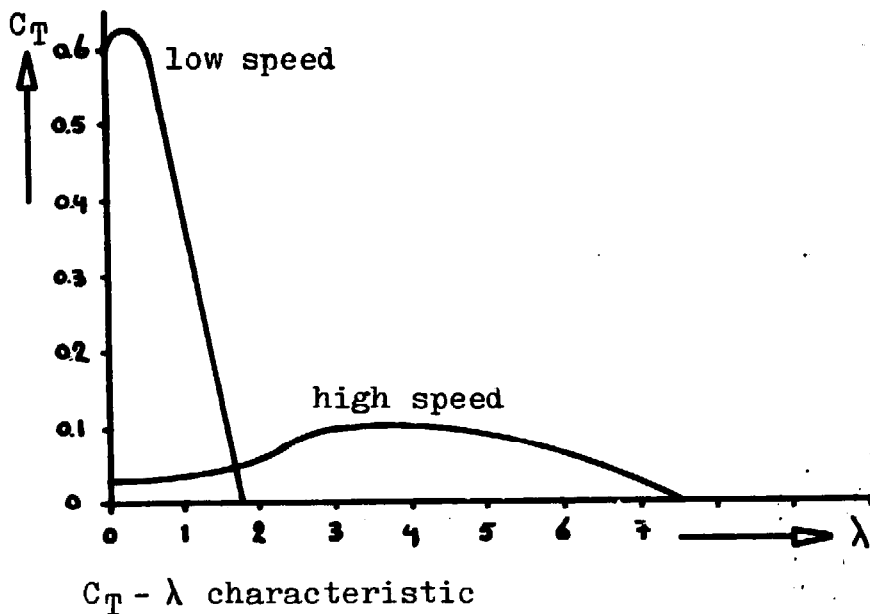

Note that the power is zero if $\lambda = 0$, but that the torque is not. See relations (4.2), (4.11).

4.4 Maximum power coefficient

The power coefficient C_p as defined with relation (4.5) describes how much power we get from the wind with a windmill. The power in the wind is given by relation (2.4). We are of course very interested in how much windpower we can transform into mechanical power with a windmill. In other words, we want to know what the highest power coefficient C_p is for a given windmill that is designed for a certain tip-speed ratio. Betz was the first one to show that the theoretically maximum attainable power coefficient is 0.593. Three other effects cause a further reduction of the maximum power coefficient. How to find the maximum power coefficient that takes these effects into account will be explained in the following:

Betz coefficient

It is not possible to transform all the wind energy that flows through cross sectional area A into mechanical energy. If we could transform all the energy in the air this would mean that we could extract all kinetic energy from the air; the air velocity behind the rotor would then be zero and no more air would flow through the rotor. The process of extracting kinetic energy from the wind will stop and no more power will be transformed. If on the other hand the air velocity behind the rotor is equal to the wind velocity, no kinetic energy has been extracted and also in this case no power will be transformed. In this way it may be understood that, if the flow velocity behind the rotor is either zero or equal to the wind velocity v , in both cases the mechanical power is zero. Between these values there is an optimum value of the wind velocity behind the rotor.

Betz found this value to be $\frac{1}{3} v$ and calculated the maximum power coefficient (Betz coefficient).

$$C_{p_{\max}} = 0.593 \quad (4.12)$$

However, this value is only valid for a theoretical design for a high tip-speed ratio, with an infinite number of blades and a blade drag equal to zero.

The effect of deviations from these three assumptions will be shown one by one in the next three paragraphs.

Maximum energy
conversion for :

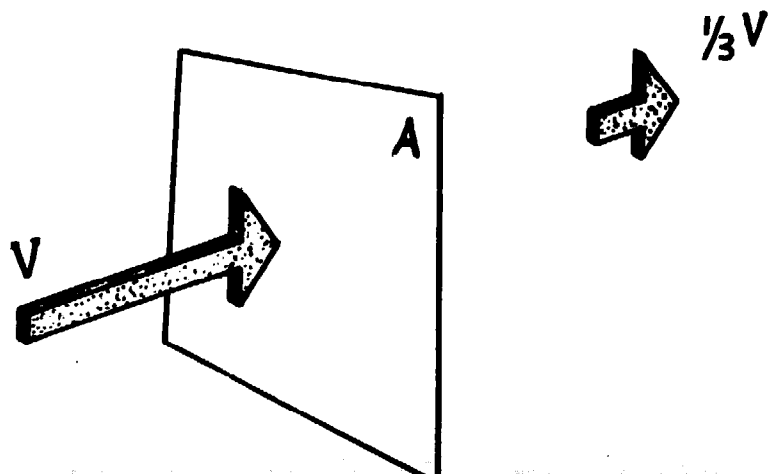

Effect of wake rotation on maximum power coefficient.

The Betz coefficient suggests that, independent of the design tip-speed ratio λ_d , we may expect a maximum power coefficient C_p of 0.593. Relation (4.12) is, however, only valid for high tip-speed ratios and for low tip-speed ratios considerable deviations exist. This can be explained in the following way:

The power is: torque x angular speed. The torque is produced by forces acting on the blades in tangential direction, multiplied by their corresponding distances to the rotor centre. These forces are the result of velocity changes of the air in tangential direction (action = reaction force = mass x velocity change per unit of time). The direction of the velocity change in the air is opposed to the direction of the forces acting on the blades. Since the air has no tangential velocity before passing the rotor, the velocity change means that behind the rotor the wake rotates in a direction opposite to that of the rotor. This wake rotation means a loss of energy because the rotating air contains kinetic energy (see relation 2.1). Since a certain amount of power is to be transformed, we know from relation (4.2) that a low tip-speed ratio (= low angular speed Ω , means that the torque T must be high. High torque means large tangential velocities in the wake; the consequence is a loss of energy and a lower power; the more so if the design tip-speed ratio is lower. The result, shown in the graph presented below, shows the collection of maximum obtainable power coefficients of ideal windmills i.e. windmills with an infinite number of blades without drag.

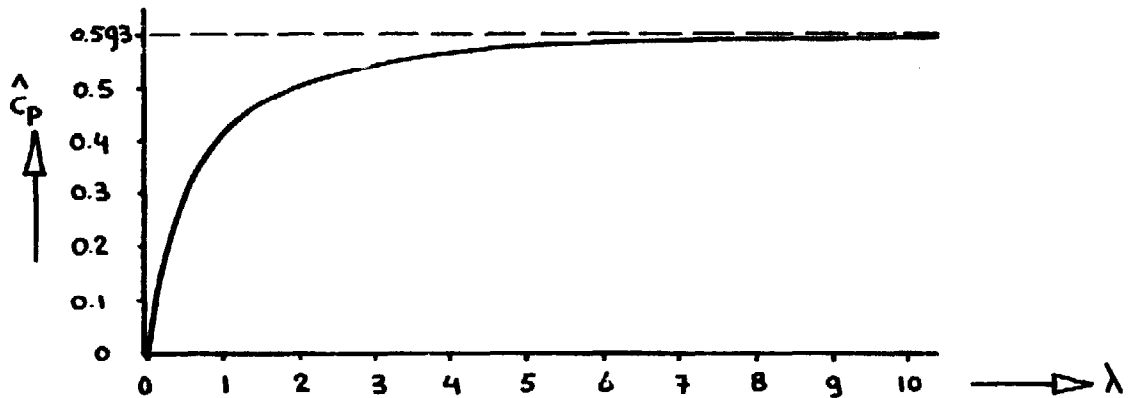

maximum power coefficients of ideal windmills

Effect of C_d/C_l -ratio on maximum power coefficient.

The factor C_d , as defined in relation (2.6) is a measure for the resistance of the blades against moving through the air. The C_d/C_l -ratio determines the losses due to this resistance. These losses are calculated and included in the collection of maximum power coefficients of the latest fig. The results are shown in fig. below.

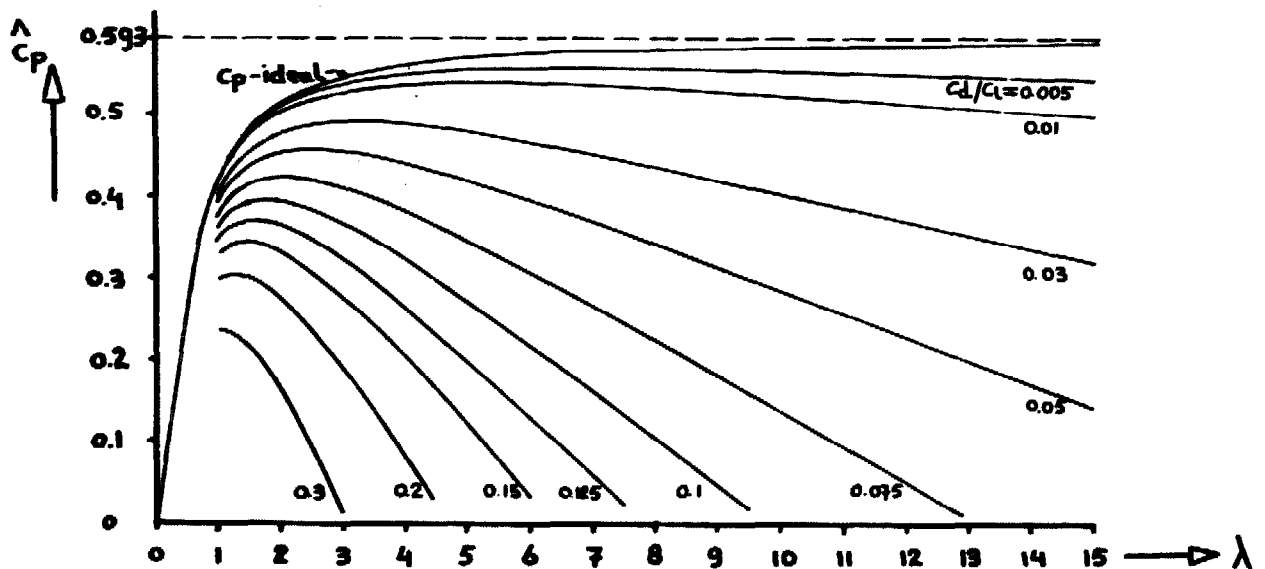

Effect of C_d/C_l -ratio on C_p -max for a rotor with an infinite number of blades.

This graph shows that a rotor, designed for a tip-speed ratio $\lambda = 2.5$ with airfoils having, for example, a minimum C_d/C_l -ratio of 0.05, will have a maximum power coefficient $C_p = 0.46$. If the rotor is designed for $\lambda = 10$, at the same C_d/C_l value, the C_p value at $\lambda = 10$ will have a maximum of 0.3.

Note that from the same graph it is clear that it is useless to design a rotor for $\lambda = 10$ with airfoils that have $(C_d/C_l)_{\min} = 0.1$.

Effect of number of blades on maximum power coefficient.

The number of the blades also affects the maximum power coefficient. This is caused by the so-called "tip-losses" that occur at the tips of the blades. These losses depend on the number of blades and the tip-speed ratio. The losses have been calculated and as example are included in the collection of maximum power coefficients for $(C_d/C_l)_{\min} = 0.03$ of the above graph. The results are shown in graph below.

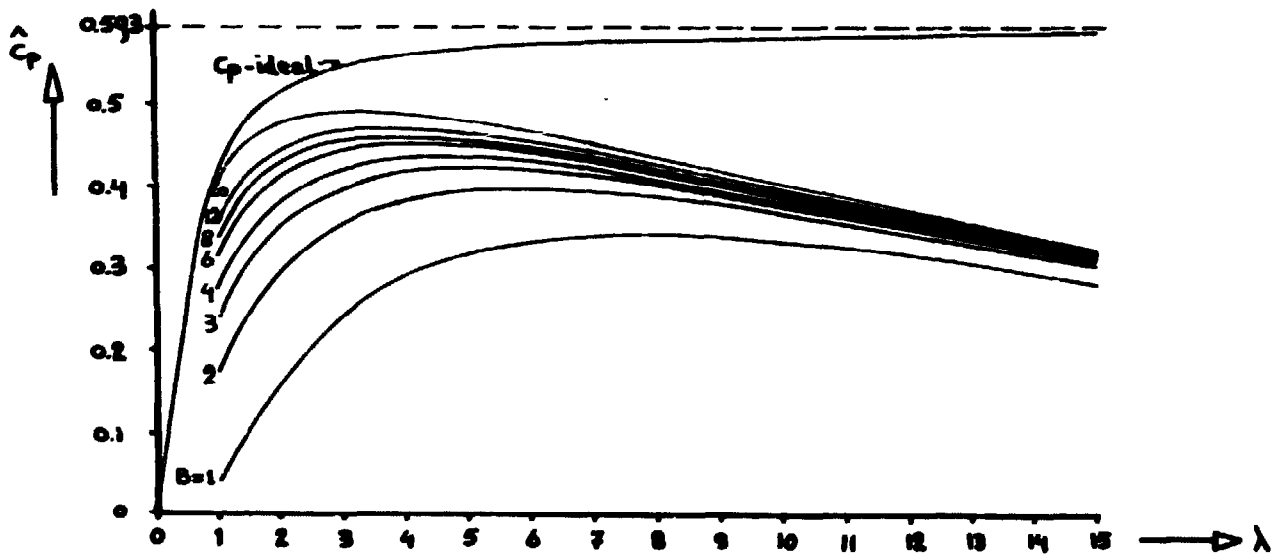

Influence of number of blades B on $C_p\text{-max}$
for $C_d/C_l = 0.03$.

In the following graph the maximum expected power coefficient is given for λ -design between 1 and 15, for a constant C_d/C_l ratio of 0.02 (arched steel plate) while the number of blades B is varied.

Conclusion: If design figures for tip-speed-ratio λ and number of arched steel plate blades B have been chosen, the expected power coefficient may be read from this graph.

Effect of number of blades for $C_d/C_l = 0.02$

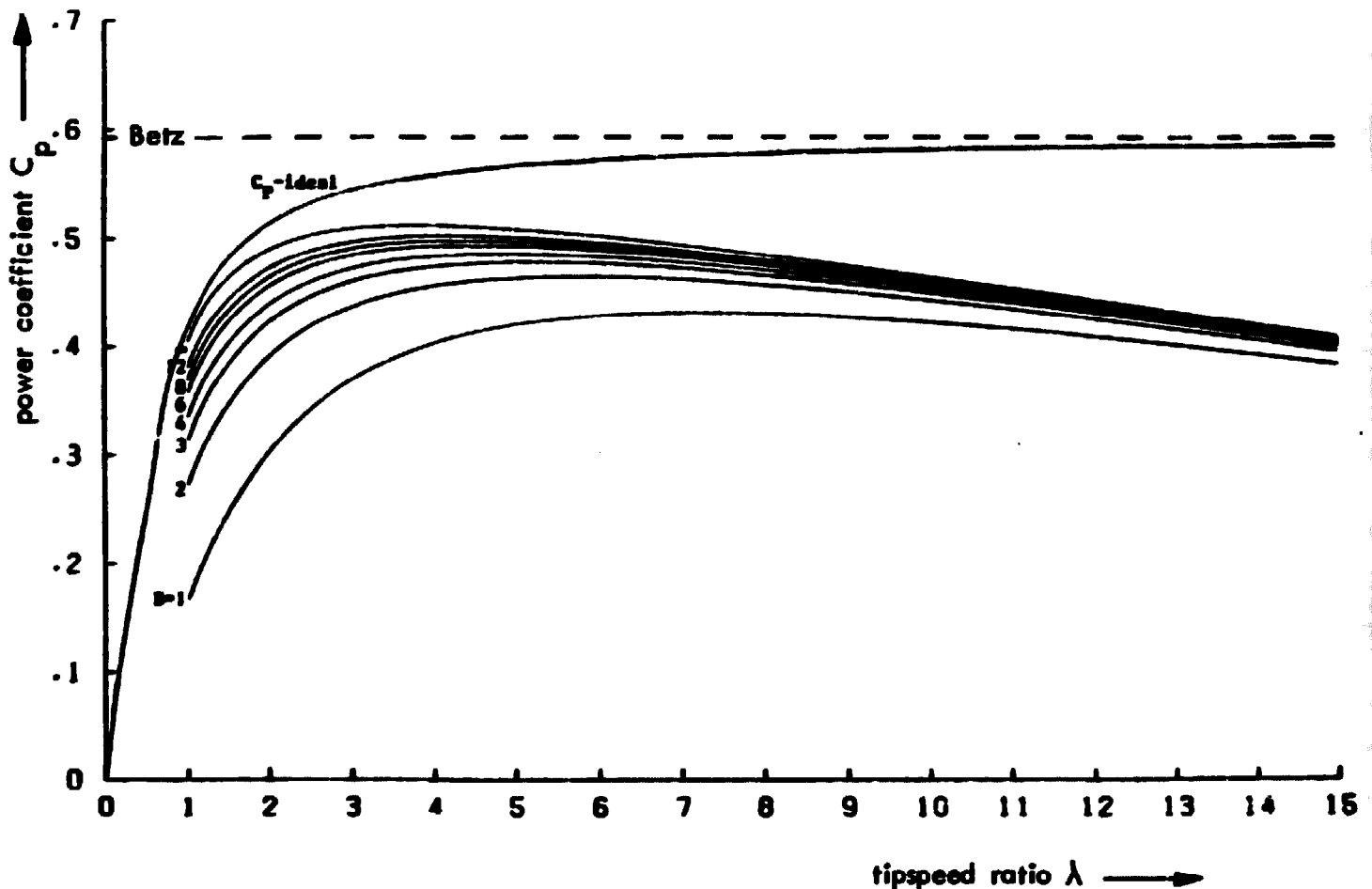

5. DESIGN OF A WINDMILL ROTOR

5.1 Calculation of blade chords and blade setting

Earlier it was shown that the selection of the number of blades B affects the power coefficient. Although B has no influence on the tip-speed ratio of a certain windmill, for the lower design tip-speed ratios in general a higher number of blades is chosen (see following table). This is done because the influence of B on C_p is larger at lower tip-speed ratios. A second reason is that choice of a high number of blades B for a high design tip-speed ratio will lead to very small and thin blades which results in manufacturing problems and a negative influence on the lift and drag properties of the blades.

Selection of
number of blades.

λ	B
1	6 - 20
2	4 - 12
3	3 - 6
4	2 - 4
5 - 8	2 - 3
8 - 15	1 - 2

A second important factor that affects the power coefficient is the drag. Drag affects the expected power coefficient via the C_d/C_l - ratio. This will influence the size and even more the optimal speed ratio (λ_o) of the design.

A large C_d/C_l - ratio restricts the design tip-speed ratio. At lower tip-speed ratios the use of more blades compensates the power loss due to drag. See graph 1. In this collection of maximum power coefficients it is seen that for a range of

design speeds $1 \leq \lambda \leq 10$ the maximum theoretically attainable power coefficients lie between $0.35 \leq C_{p \max} < 0.5$.

Due to deviations, however, of the ideal geometry and hub losses for example, these maximums will lie between 0.3 and 0.4. This result shows that the choice of the design tip-speed ratio hardly affects the power output. Two other factors, however, limit the choice of the design tip-speed ratio. One is the character of the load that in most cases will require a high starting torque, the design speed of the rotor will usually be chosen low; this allows the designer to use simple airfoils like sails or steelplates. If the load is fast running like a generator or a centrifugal pump, then a high design speed will be selected and airfoils with a low C_d/C_l - ratio will be preferred. The second factor is that the locally available technologies will often restrict the possibilities of manufacturing blades with airfoils having low C_d/C_l - ratios. But even in the case of high speed design, simple airfoils like arched steel plates, can give very good results.

For design of the blades we need the following data:

Rotor radius	R [m]
Number of blades	B [-]
Design tip-speed ratio	λ [-]
Airfoil data: C_d/C_l -ratio	[-]
Design lift coefficient	C_l [-]
Corresponding angle of attack	α [-]

Once these data are known it is now very simple to calculate the blade geometry; i.e. the chord c of the blade and the blade angle β , the angle between the chord and the plane of rotation.

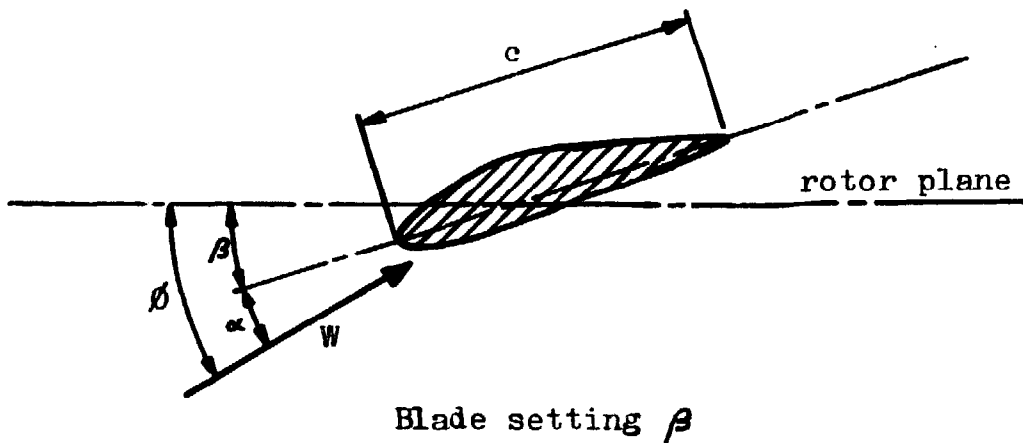

Only four simple formulas are needed:

$$\lambda_r = \lambda_o \times r/R \quad (5.1)$$

$$c = \frac{8\pi r}{BC_1} (1 - \cos\phi) \quad (5.2)$$

$$\beta = \phi - \alpha \quad (5.3)$$

$$\phi = \frac{2}{3} \arctan \frac{1}{\lambda_r} \quad (5.4)$$

The latter relation is also presented in table 1, Appendix I.

The underlying theory is too complicated to be explained here. The reader who is primarily interested in the design of the rotor, can do without this theory.

Now the design procedure is as follows:

Divide the blade with radius R in a number of parts of equal length. In this way we find cross sections of the blade. Each cross section has a distance r to the rotor centre and has a local speed ratio λ_r , according to (5.1).

In appendix I we can find the corresponding angle ϕ for each cross section. ϕ is the angle of the relative air-velocity W that meets the blade section at radius r . We now calculate the chord with relation (5.2). For the sake of ease, $(1 - \cos\phi)$

has been added in the table of appendix I. The blade angle at the corresponding radius is found with (5.3).

As an example we will take the 12 PU 500 windmill with:

$$\begin{aligned} R &= 2.5 \quad [\text{m}] \\ B &= 12 \\ \lambda_0 &= 2 \end{aligned}$$

Airfoil: 10% arched steel plate
with:

$$\begin{aligned} C_1 &= 1.25 \quad (\text{i.e. the value for minimum } (C_d/C_1)) \\ \alpha_0 &= 3^\circ \quad (\text{i.e. the corresponding angle of attack}) \end{aligned}$$

With equations (5.1) and (5.2), (5.3) we can now compute the values of the following table:

Cross section number	r [m]	λ_r	ϕ°	α_0°	β°	c [m]
1	0.5000	0.4	45.6	3	42.6	0.252
2	0.6250	0.5	42.3	3	39.3	0.273
3	0.9550	0.76	35.2	3	32.2	0.293
4	1.2500	1.00	30.0	3	27.0	0.281
5	1.5625	1.25	25.8	3	22.8	0.260
6	1.9100	1.53	22.1	3	19.1	0.235
7	2.1875	1.75	19.8	3	16.8	0.217
8	2.5000	2.00	17.7	3	14.7	0.198

The result is the blade chord c and the blade setting β at various stations along the blades. Plotting the chords gives the blade form and plotting β shows the desired twist of the blade.

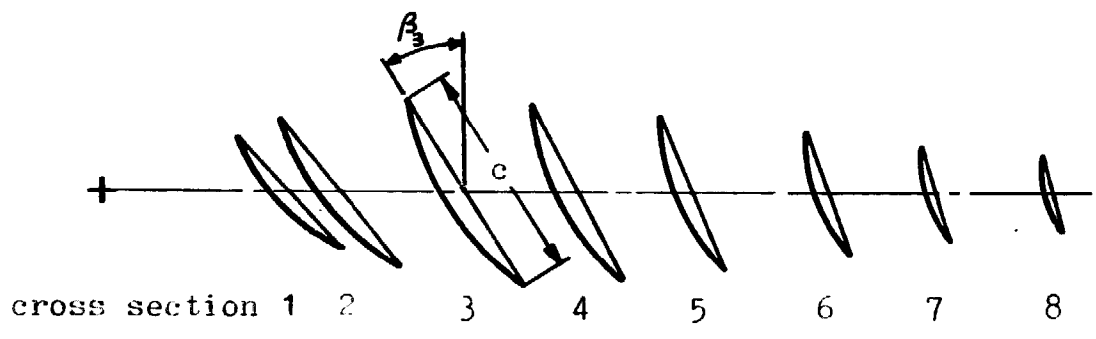
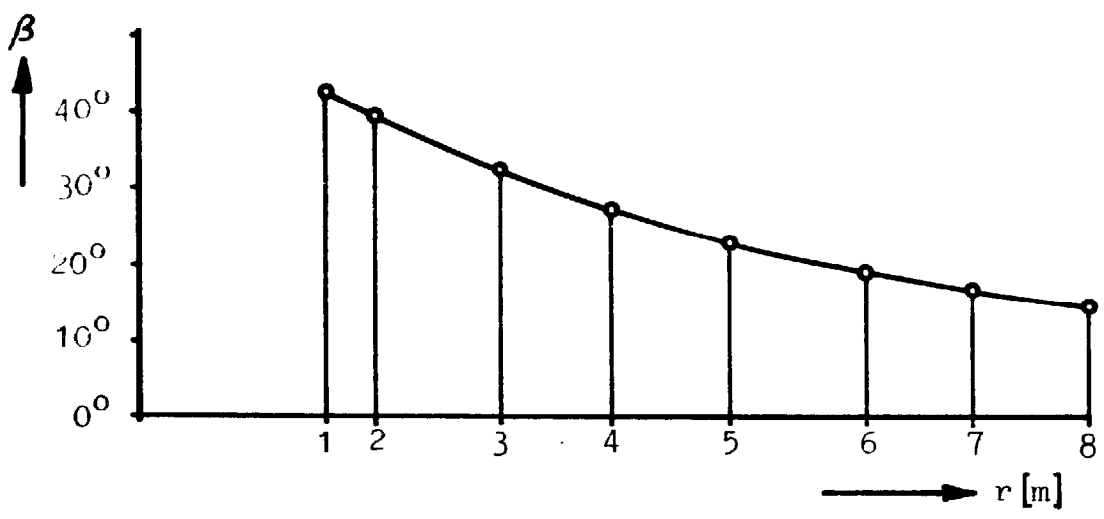
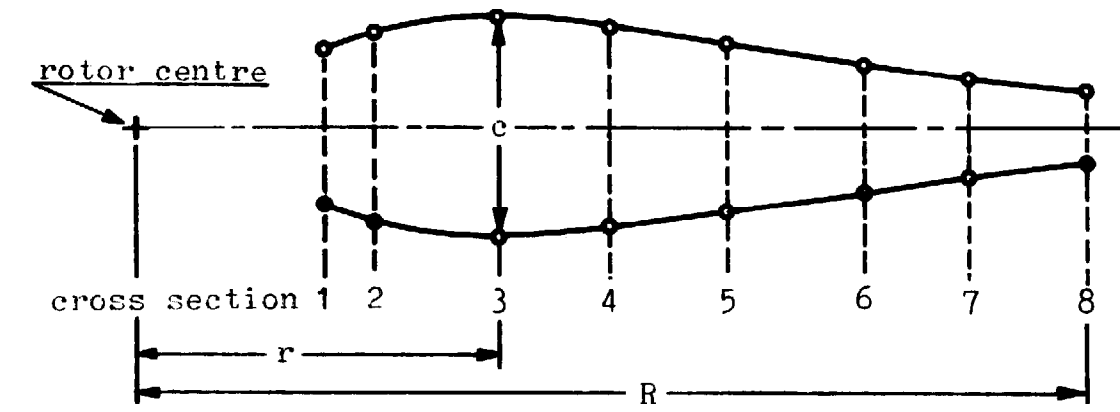

Blade chord and blade setting at various stations along the blade.

5.2 Deviation of the calculated chords and blade setting

In the last paragraph we showed how to calculate the ideal blade form. The chords as well as the blade angles as calculated vary in a non-linear manner along the blade. Such blades are usually difficult to manufacture and lead to an uneconomic use of materials. In order to reduce these problems it is possible to linearize the chords and the blade angles. This results in a small loss of power. If the linearization is done in a sensible way the loss is only a few percent.

In considering such linearizations it must be realized that about 75% of the power that is extracted by the rotor from the wind, is extracted by the outer half of the blades. This is because the blade-swept area varies with the square of the radius; also the efficiency of the blades is less at small radii, where the speed ratio λ_r is small. On the other hand, at the tip of the blade the efficiency is low due to the tip losses.

For reasons mentioned above, it is advised to linearize the chords c and the blade angles β between $r=0.5 R$ and $r=0.9 R$ without too much deviation to the computed theoretical values.

Example: We linearize the blade chords c and the angles β as calculated.

The nearest value of r to $0.5 R$ in the table is $r=1.25$ ($= 0.5 R$). The nearest value of r to $0.9 R$ is $r=2.1875$ ($= 0.875 R$).

We can now linearize the chords by writing c in the following way: $c = a_1 r + a_2$

With the values of c at $r = 1.25$ and $r = 2.1875$ the constants a_1 and a_2 are found as follows:

$$0.281 = 1.25 a_1 + a_2$$

$$0.217 = 2.1875 a_1 + a_2$$

$$0.064 = -0.9375 a_1$$

$$\rightarrow a_1 = -0.068$$

$$0.281 = -0.068 \times 1.25 + a_2$$

$$\rightarrow a_2 = 0.366$$

$$\text{So } c = -0.068 r + 0.366$$

Suppose we have the foot of the blade at $r = 0.2 R$ (at smaller radii the contribution of the extracted energy is neglectable, the more so in relation to the material required for the blades), then we can calculate the chords at the foot and at the tip of the blade.

$$c_{\text{foot}} = -0.068 \times 0.5 + 0.366 = 0.332$$

$$c_{\text{tip}} = -0.068 \times 2.5 + 0.366 = 0.196$$

In order to see which deviation is introduced by linearization of the blade at the various cross sections, the computed values for the chords are given in the following table.

cross section number	r [m]	c [mm] exact	c [mm] first linearization	c [mm] second linearization	deviation [mm]
1	0.5000	252	332	250	2
2	0.6250	273	324	(264)	9
3	0.9550	293	301	300	7
4	1.2500	281	281	(281)	0
5	1.5625	260	260	(261)	1
6	1.9100	235	236	(238)	3
7	2.1875	217	217	(222)	5
8	2.5000	198	196	200	2

From this table it can be seen that considerable deviations occur at the two bottom sections of the blade (cross section 1 and 2).

Therefore a second linearization will be useful for those two sections, the more so in relation to the material requirements for the blades. At the same time rounded figures can be chosen for the relevant measurements of the blade.

So the first linearization provides us with $c = 200$ mm for the tip and $c = 300$ mm for cross section number 3, while the second linearization provides us with $c = 250$ mm for the foot of the blade.

The actual deviations then existing are shown in the last column of the above table.

Linearization of the blade angles β (or the blade twist) can be done in a similar way. However, here we first have to decide how the blades will be fixed to the rotor frame. In case the blades are fixed to the rotor frame at two positions then only one linearization is possible since a straight line is defined by 2 points.

Suppose the blades are supported in cross section number 3 and 6 (which is about at $1/4$ and $3/4$ of the blade length) then the angles β can be found as follows:

β can be written in the following way $\beta = a_3 r + a_4$
 With the values of β at $r = 0.955$ (cross section 3) and at $r = 1.910$ (cross section 6) the constants a_3 and a_4 are found as follows:

$$32.2 = a_3 \times 0.955 + a_4$$

$$19.1 = a_3 \times 1.910 + a_4$$

$$13.1 = -0.955 a_3$$

$$a_3 = -13.72$$

$$32.2 = -13.72 \times 0.955 + a_4$$

$$a_4 = 45.3$$

$$\text{So } \beta = -13.72 r + 45.3$$

The computed values for β at the various cross sections are presented in the following table.

cross section number	r[m]	β [°] exact	β [°] linearized	deviation [°]
1	0.5000	42.6	38.4	4.2
2	0.6250	39.3	36.7	2.6
3	0.9550	32.2	32.2	0
4	1.2500	27.0	28.2	1.2
5	1.5625	22.8	23.9	1.1
6	1.9100	19.1	19.1	0
7	2.1875	16.8	15.3	1.5
8	2.5000	14.7	11.0	3.7

The result of the linearization is visualized in the following graphs where blade form and blade twist are shown.

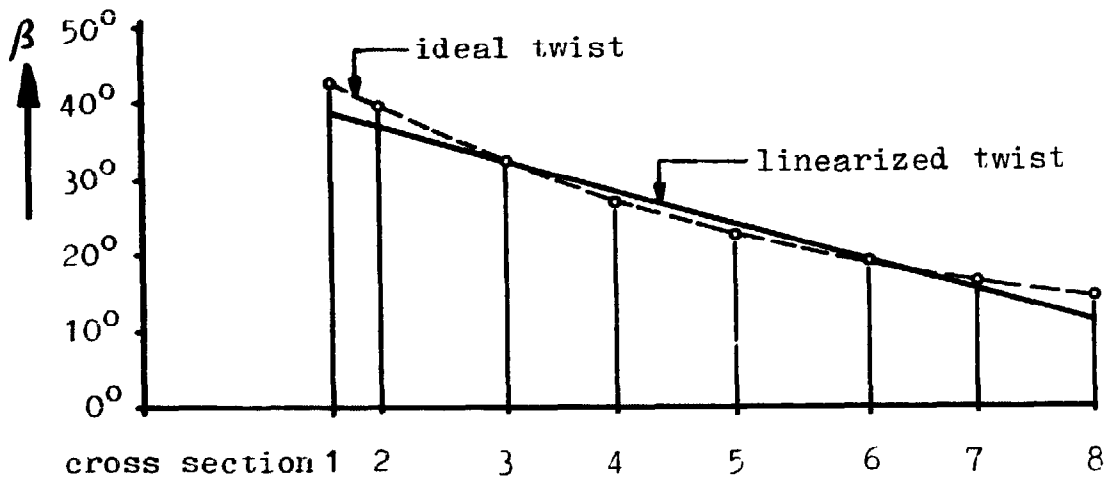
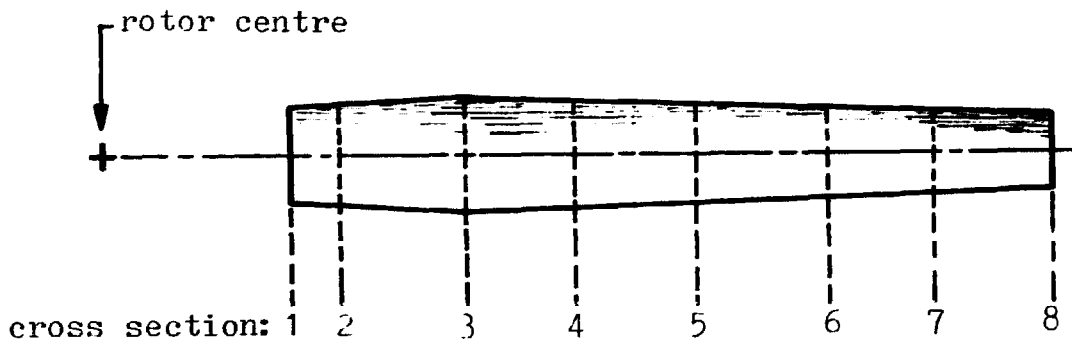

5.3 Calculation of the radius of the curve of the blade

The radius of the curve of the blade is depending on the chord of the blade. For a 10% arched steel sheet ($f/c = 0.10$) the relation of radius and chord can be derived as follows.

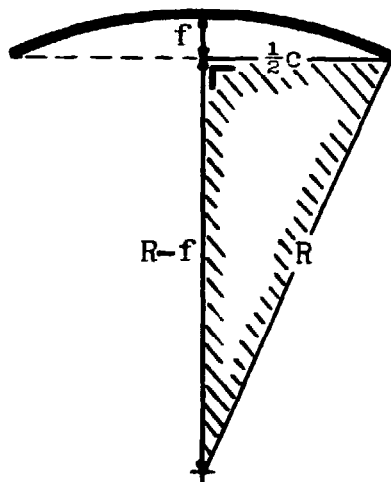

From this figure we will see that in the right-angled triangle the following relation is valid

$$R^2 = (R - 0.1 c)^2 + (1/2c)^2$$

Worked out it will give us

$$\boxed{R = 1.3 c} \quad (5.8)$$

For a 7% arched steel sheet the relation will be

$$\boxed{R = 1.8 c} \quad (5.9)$$

In our calculation example we assumed the blade to be supported in cross section 3 and 6. The corresponding chords are 300 mm resp. 238 mm. So the radii of the curves of the blade at those positions and of course of the blade supports as well have to be:

in cross section 3 : $R = 1.3 \times 300 = 390$ mm and

in cross section 6 : $R = 1.3 \times 238 = 310$ mm.

5.4 Measurements of the blade.

In our calculation example we found the chord of the blade. This is, however, not the cutting measurement of the blade. Therefore we have to calculate the length of the segmental arc with the computed chords.

For a 10% curved blade we can calculate this as follows:

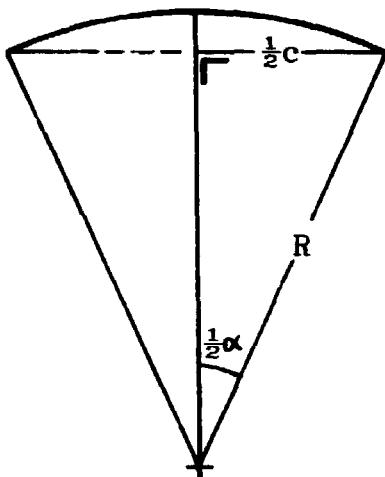

$$\left. \begin{aligned} \sin \frac{1}{2}\alpha &= \frac{c}{2R} \\ R &= 1.3 c \end{aligned} \right\} \begin{aligned} \sin \frac{1}{2}\alpha &= \frac{1}{2.6} \\ \alpha &= 45.2^\circ \end{aligned}$$

$$\left. \begin{aligned} \text{arc} &= 2 \pi R \frac{\alpha}{360} \\ &= 2 \pi R \frac{45.2}{360} \\ R &= 1.3 c \end{aligned} \right\} \text{arc} = 2 \pi \times 1.3c \frac{45.2}{360}$$

$\text{arc} = 1.026 c$

This correction of 2.6% is to be neglected.

6. DESIGN AND STRENGTH ASPECTS OF THE WINDMILL

6.1 Strength calculations.

6.1.1 Strength calculations of the rotor of the 12 PU 500 windmill.

On the blades are acting the centrifugal forces and the thrust forces of the wind. For the calculation of the centrifugal forces we assume a wind velocity of 20 m/s and an unloaded windmill. This means that the tip-speed ratio will be about 1,65 times more than in case the windmill is matched to a proper load.

The angular speed will be:

$$\Omega = \frac{\lambda \cdot v}{r} = \frac{1.65 \times 2 \times 20}{2.5} = 26 \text{ rad/sec}$$

The formula for the centrifugal force is

$$F_c = \frac{mv^2}{r} \quad \text{or} \quad F_c = m \Omega^2 r$$

The mass of one blade is approx. 4 kg and the centre of gravity of the blade is situated at a radius of approx. 1.5 m.

$$F_c = m \cdot \Omega^2 \cdot r = 4 \times 26^2 \times 1.5 = 4056 \text{ N}$$

To calculate the number of bolts one has to fit the blade with, we first have to calculate the maximum load which can be taken by one 1/4" bolt.

$$\text{The area of a } 1/4'' \text{ bolt is } \frac{\pi}{4} \cdot 4.8^2 = 18 \text{ mm}^2$$

The allowable unit stress for steel is 120 N/mm²

So one bolt can take 18 x 120 = 2160 N

The minimum required number of bolts has to be $\frac{4056}{2160} = 1.6$.

In fact the complete centrifugal load of the blade is taken up by the inner ring, since this one is much more rigid than the outer ring.

Although 2 bolts should have been sufficient, from the strength point of view, there are 3 bolts applied in order to maintain a proper curve of the blade. For the outer ring 2 bolts have been applied in order to support the blade properly.

6.1.2 Strength calculations of the tower.

The major forces acting on the tower are the thrust force of the rotor, the weight of the total head construction, tail and rotor and the pumprod forces.

To calculate the thrust force created by the wind we apply the following formula:

$$F_p = \frac{8}{9} \times 1/2 \rho V^2 A \quad (6.1)$$

$$F_p = \text{thrust force (Newton)}$$

$$\frac{8}{9} = \text{Thrust coefficient}$$

$$\rho = \text{Density of air (1.2 kg/m}^3\text{)}$$

$$V = \text{Wind velocity (m/s)}$$

$$A = \text{Swept area (m}^2\text{)}$$

Although the windmill is put automatically in secured position if the windspeed exceeds 10 m/sec, we will make the calculation for a windspeed of 20 m/sec. So even in case the security mechanism fails, the strength of the system (and the structure) will be sufficient to withstand the forces acting on it in a windspeed of 20 m/s.

Note that for normal operation, in a windspeed of 10 m/s, a safety factor of

$$\frac{20^2}{10^2} = 4 \text{ is obtained.}$$

For a rotor with a diameter of 5 m the thrust force will be:

$$F_p = \frac{8}{9} \times 1/2 \times 1,2 \times 20^2 \times \frac{\pi}{4} \times 5^2 = \underline{\underline{4189 \text{ N}}}$$

The weight of the total head construction, tail and rotor of the 12 PU 500 windmill is approx. 300 kg. This results in a vertical force of 3000 N , acting on the tower.

Pumprod forces are assumed not to exceed 3000 N during the upward movement of the piston.

So the total vertical force acting on the tower amounts to 6000 N.

In the following diagram these forces are situated at the rotor centre.

The thrust force causes also a bending moment acting on the tower which is also shown in the same diagram.

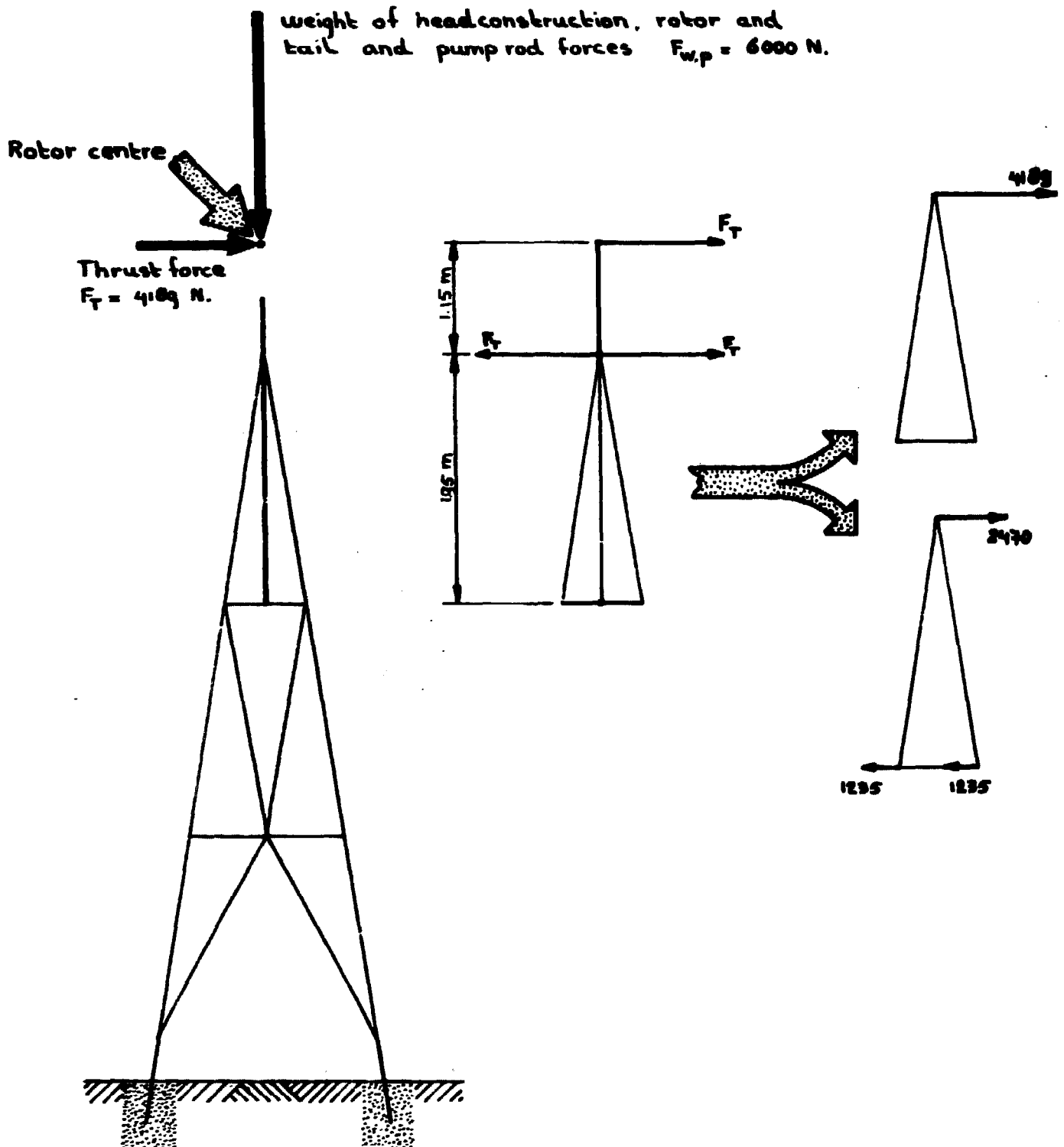

CREMONA DIAGRAM

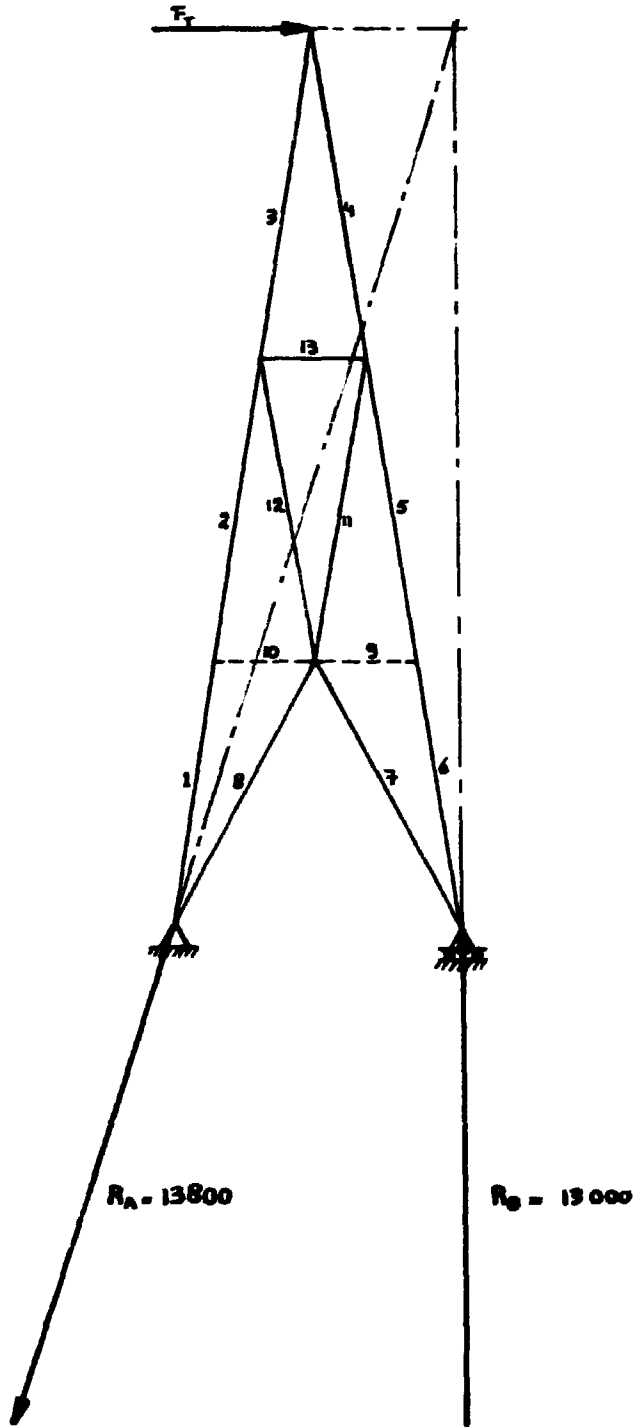

member forces exerted by
Thrust force : $F_T = 4189 \text{ N}$

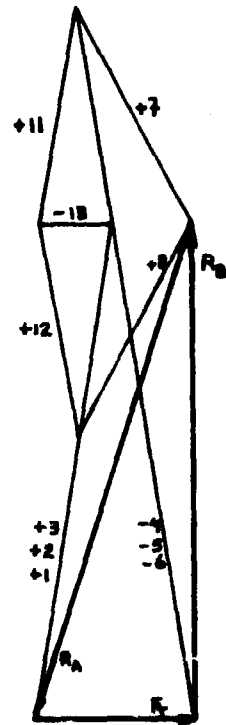

1 cm $\hat{=}$ 2000 N

No	tension	thrust
1	7200	
2	7200	
3	13200	
4		13200
5		19000
6		19000
7	6400	
8	6400	
9	—	—
10	—	—
11	5800	
12	5600	
13		1900

CREMONA DIAGRAM

Member forces exerted by bending moment due to thrust load $M_b = 4817 \text{ Nm}$.

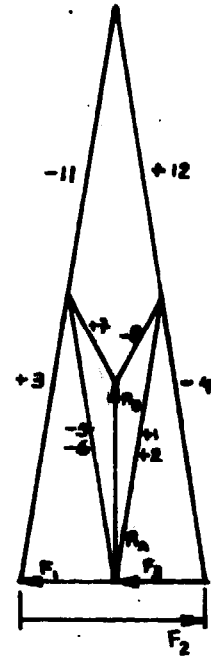
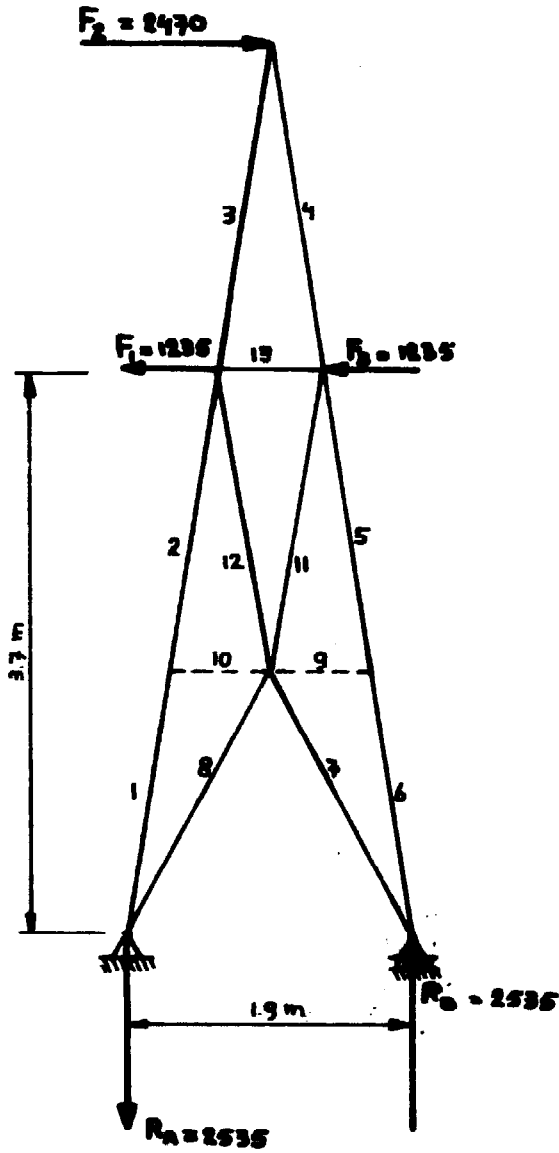

1 cm \cong 1000 N.

No	Tension	Thrust
1	3700	
2	3700	
3	7700	
4		7700
5		3700
6		5700
7	1300	
8		1300
9	—	—
10	—	—
11		3900
12	3900	
13	0	0

CREMONA DIAGRAM

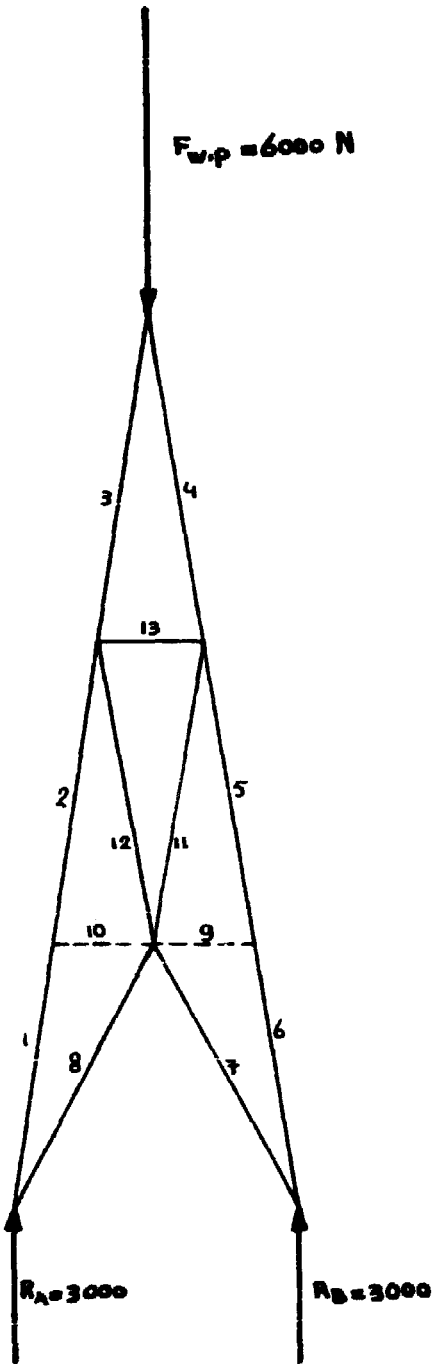

Member forces exerted by weight of head construction, rotor and tail and by pumped forces : $F_{w.p} = 6000$ N.

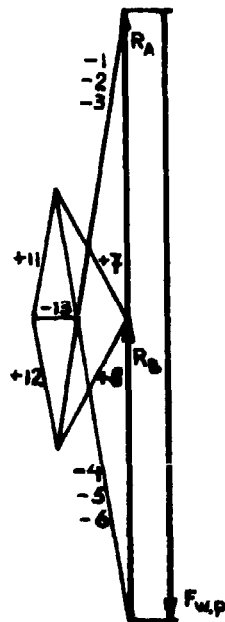

No	tension	thrust
1		4350
2		4350
3		3075
4		3075
5		4350
6		4350
7	1425	
8	1425	
9	—	—
10	—	—
11	1275	
12	1275	
13		412

1 cm $\hat{=}$ 750 N.

With help of Cremona diagrams the member forces of the lattice tower have been derived on the fore going pages. These member forces are derived for each separate load acting on the system. The final resulting member forces are as follows: (in Newtons)

No	Tension	Thrust
1	6550	
2	6550	
3	17825	
4		23975
5		27050
6		27050
7	9125	
8	6525	
9	-	-
10	-	-
11	3175	
12	10775	
13		2312

It can be seen that the maximum thrust force occurs in the members 5 and 6 (and in 1 and 2 if the wind direction is opposite). Because it is a four-leg tower this force is distributed among 2 legs.

So the thrust load on one leg is 13525 N.

The unit stress in compression of the angle irons of the tower legs can be calculated as follows:

For angle iron 40 x 40 x 5 mm, we can find from handbooks the following data:

$$\begin{aligned} \text{cross section area } A &= 3.79 \text{ cm}^2 \\ \text{Moment of inertia } I_v &= 2.26 \text{ cm}^4 \\ \text{Radius of gyration } i_v &= 0.77 \text{ cm.} \end{aligned}$$

The maximum buckling length is 2 m ($l = 200 \text{ cm}$) and the members can be considered as fixed in between rigid joints. So the slenderness ratio will become

$$\lambda = \frac{l/2}{i_v} = \frac{100}{0.77} = 130$$

For normal construction steel the allowable unit stress in compression for this slenderness ratio of 130 will be (according handbooks) $\sigma_{130} = 3500 \text{ N/cm}^2$.

The true stress is given by:

$$\sigma = \frac{\text{buckling force}}{\text{cross section area}} = \frac{13525}{3.79} = 3569 \text{ N/cm}^2.$$

This is approx. the maximum allowable.

On the diagonals of the tower (members 7 to 12) only tension forces occur with a maximum of $10775/2 = 5388 \text{ N}$ for member 12 (and 11 for winds from opposite direction).

These members consists of angle iron 30 x 30 x 4 with a cross section area A of 2.27 cm^2 .

The true stress set up in these angle irons is given by:

$$\sigma = \frac{\text{tension force}}{\text{cross section area}} = \frac{5388}{2.27} = 2374 \text{ N/cm}^2.$$

The allowable tension stress for construction steel is $\sigma_t = 14000 \text{ N/cm}^2$.

It can also be noticed that the members 9 and 10 are not carrying any load. They can, however, not be omitted because they halve the buckling length of the members 1,2 and 5,6.

We may conclude that this tower design can withstand even those forces which would occur with a windmill in working position at a wind speed of 20 m/s, whereas the normal limit of operation is at 10 to 12 m/s.

6.1.3 Bearings.

Selection of the proper bearing for a given application may be a difficult problem, but some general principles can be set down.

Ball bearings are usually the most economical choice for the smaller sizes and lighter loads; roller bearings are usually more satisfactory for the larger sizes and heavier loads. Roller bearings have considerably less sensitivity to shock loading than ball bearings. Most bearings lose capacity if misaligned any measurable amount, but self-aligning bearings can take 2 or 3 degrees of misalignment without loss in capacity.

A major influence on bearing choice is the direction and magnitude of the load. Self-aligning ball bearings are designed primarily to carry light and moderate radial loads, but can carry some thrust load in either direction. Deep-groove ball bearings are designed to carry light, medium or heavy radial or combined loads. These bearings can carry substantial thrust loads.

In the following table the characteristics of a single groove bearing and a self-aligning bearing with a 50 mm bore (medium series, easily available) are given (SPK-bearings).

50 mm bore.	Single groove	Self-aligning
Dyn. ref capacity C	47000	39000
Thrust factor Y	1 - 1.5	3.2
Rotation factor X	1	1

The thrust force acting on the rotor of the 12 PU 500 windmill at a windspeed of 10 m/s is calculated with (6.1) as $F_a = 1047 \text{ N}$.

We assume that this thrust force is completely taken by the front bearing.

The radial load acting on this bearing is caused by the weight of the rotor and is calculated as follows:

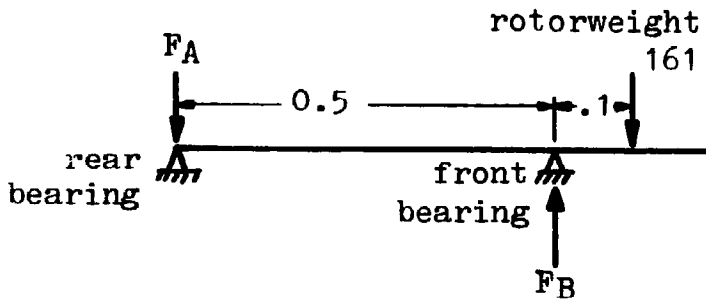

The rotorweight amounts to 161 kg and the centre of gravity is located at approx. 0.1 m from the front bearing.

The distance between the two bearings is 0.5 m.

According the conditions of equilibrium, the reaction forces can be calculated from:

$$\sum M = 0$$

$$\begin{aligned} \text{With regard to A:} \quad & 1610 \times 0.6 - F_B \times 0.1 = 0 \\ & F_B = 1930 \text{ N} \end{aligned}$$

$$\begin{aligned} \text{and from } \sum H = 0 \quad & F_A + 1610 - 1930 = 0 \\ & F_A = 320 \text{ N} \end{aligned}$$

Now the equivalent thrust load, defined as

$$P = X \cdot F_r + Y \cdot F_a \quad (6.2)$$

can be calculated for the front bearing as

$$P = 1 \times 1930 + 1.25 \times 1047 = 3239 \text{ N.}$$

At a windspeed of 10 m/s the revolution speed of the rotor will be approx. 110 RPM.

$$\text{So the RPM factor becomes: } f_n = \sqrt[3]{\frac{33.3}{n}} = \sqrt[3]{\frac{33.3}{110}} = 0.67$$

$$\text{and } f_h = \frac{f_n \cdot C}{p} = \frac{0.67 \times 47000}{3239} = 9.72$$

This results in a lifetime L_H according to:

$$L_H = 500 f_h^3 \quad (6.4)$$

$$L_H = 500 \times 9.72^3 = 459165 \text{ hours.}$$

With an average of 5000 running hours per year the life of the bearing will be about 92 years. This is, however, only valid if the bearing is running under proper conditions,

well greased in dust free housings, etc. Under field conditions the life will be reduced depending upon the degree of maintenance, proper alignment, etc.

For the calculation of the rear bearing, we have two radial loads acting on the bearing. One is caused by the weight of the rotor and has been calculated earlier as 320 N. The other is caused by the pumprod forces.

The magnitude of these pumprod forces is not exactly known, but is assumed to be 5000 N during the upward movement of the piston. During the downward movement of the piston the direction of the pumprod forces is opposite, but also limited. So the maximum load acting on the rear bearing is:

$$5000 - 320 = 4680 \text{ N.}$$

The equivalent thrustload is now

$$P = x \cdot F_r + YFa = 4680 \text{ N}$$

$$\text{and } f_h = \frac{f_n \cdot C}{P} = \frac{0.67 \times 47000}{4680} = 6.73$$

So $L_H = 500 f_h^3 = 500 \times 6.73^3 = 152410$ hours,
which means a life of 30 years.

For the self-aligning bearing these values are for the rotor side bearing calculated as 12 years and for the rear bearing as 17 years.

It may be concluded from these calculation examples, that both types of bearings may serve the purpose. However, in case single groove ball bearings are used, proper alignment is most essential for the life of the bearings (and a straight shaft as well of course).

6.2 Flywheel energy of the rotor.

A flywheel is primarily a rotating energy reservoir performing two distinct classes of service. First, the flywheel absorbs energy from a power source during the greater portion of the operating cycle and delivers a large amount of energy as useful work in a very short portion of the cycle. This class includes punch presses and shears. In the second class, including steam engines, internal-combustion engines, compressors and reciprocating pumps, the flywheel smooths out the speed fluctuations caused by non-uniform flow of power from the piston during each energy cycle.

A windmill rotor is also to be included in the second class where the rotor is also acting as a flywheel in combination with the reciprocating piston pump.

The kinetic energy E (J) in a rotating flywheel is

$$E = \frac{1}{2} W U^2$$

Where in W = Weight of wheel (kg)

U = Velocity at radius of gyration (m/s)

If the velocity changes from U_1 to U_2 the energy fluctuation is:

$$\Delta E = \frac{1}{2} W (U_1^2 - U_2^2)$$

We will make a calculation example for the 12 PU 500 windmill at a wind velocity of $v = 6$ m/s.

The weight of the complete rotor is 161 kg. The radius of gyration is assumed as 1.25 meter. The tangential velocity at $r = 1.25$ m in a wind velocity of $v = 6$ m/s and with a tipspeed ratio of $\lambda = 2$ is:

$$U = \frac{r}{R} \cdot \lambda \cdot v = \frac{1.25}{2.5} \times 2 \times 6 = 6 \text{ m/s.}$$

So $E = \frac{1}{2} W U^2 = \frac{1}{2} \times 161 \times 6^2 = 2900 \text{ J.}$

The energy fluctuation can be determined by calculating the generated energy as follows:

The torque generated by the windmill at a wind speed v is: (relation 4.10 and 4.11)

$$T = \frac{1}{2} \rho v^2 \pi R^3 \cdot C_t \quad \text{and} \quad C_t = \frac{C_p}{\lambda}$$

$$\text{For } \lambda = 2 \rightarrow C_t = \frac{0.38}{2} = 0.19$$

$$\text{So } T = \frac{1}{2} \times 1.2 \times 6^2 \times \pi \times 2.5^3 \times 0.19 = 201 \text{ Nm.}$$

For one revolution this presents an amount of energy of $201 \times 2\pi = 1263 \text{ J}$

Summarising this we conclude that the energy stored in the flywheel (= rotor) is 2900 J and that the energy generated during one revolution is 1263 J, which is the maximum the pump can "ask", (at a wind speed of 6 m/s) at an average.

In the following graph this is made visible.

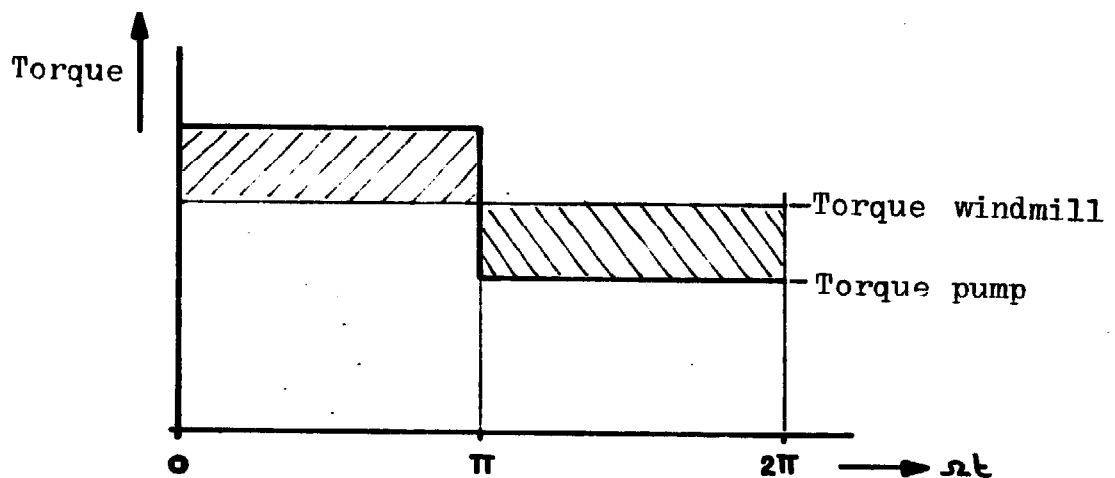

6.3 Towerheight.

The cost price per kwh (C_E) generated by a windmill is given by the following relation

$$C_E = \frac{\text{Total initial investment} + \text{rec.cost} + \text{maintenance cost}}{\text{Total energy generated during the same period.}}$$

For the various existing windmills it has been discovered that a minimum for C_E is obtained for $1.2 < \frac{H}{D} < 1.7$

H = Height of tower

D = Rotor diameter

The actual costprice per kWh is naturally depending on the actual wind pattern in a particular area.

If we make the calculation for a 12 PU 500 windmill in Ghazipur area, we will get the following result, with the following assumptions made.

Cost price of windmill	Rs. 7000
Lifetime of windmill	15 years
Yearly maintenance cost	Rs. 200/year
Yearly pumped quantity of water	20000 m ³
Over a total head of	6 metres
Rate of interest 10% (i=0.10)	

We have to calculate with an annuity factor (a) of

$$a = \frac{i \times (1 + i)^n}{(1 + i)^n - 1} = a = \frac{0.10 \times (1 + 0.10)^{15}}{(1 + 0.10)^{15} - 1} = 0.131474$$

The total energy generated can be calculated as follows:
(in kwh)

$$E = \frac{\rho \cdot g \cdot H \cdot Q}{1000 \times 3600} = \frac{1000 \times 10 \times 6 \times 15 \times 20000}{1000 \times 3600} = 5000 \text{ kWh.}$$

If we apply the formula for the cost price calculation per kwh it will give us:

$$C_E = \frac{0.13147 \times 7000 \times 15 + 15 \times 200}{5000} =$$

$$\frac{13804 + 3000}{5000} = \frac{16804}{5000} = \text{Rs. } 3.36 / \text{kwh}$$

It must be stressed that this kWh-price (as calculated for the windmill) should not be compared directly with kWh-prices of electricity. All losses of the system (pump, rotor losses) have been taken into account in calculating this price. With 1 kWh electrical energy an electric motor-pump unit must be driven which has an efficiency of less than 50%. The real kWh-price is thus at least twice as high.

7. WIND ANALYSES

To investigate what type of windmill will be the most suitable one in particular area and to estimate the economic benefits which can be derived by application of windmills for waterpumping, analyses of the wind potential in the area is the main instrument. This chapter will deal with the way, how to analyse wind data for this purpose.

7.1 Availability of data

Often wind data are registered at meteo-stations and at airports. At most meteo-stations, however, only daily or monthly averages are collected and published. These long-time averages are only of limited value for our purpose as we will see later. At airports mostly hourly wind-speed data are registered during day time, when the airport is in operation. Only at big international airports continuous registration is practised. Sometimes it is hard to obtain these data, since often these data are not published. As we will see further on in this chapter it is essential, to have data from a number of years to get an impression about the variability of the wind in the area.

7.2 Reliability of the data

Wind is one of the most fluctuating meteorological features and influenced by all types of disturbances topographical hinderances as well as air disturbances.

Since it takes often too much time to collect wind data in the place where the windmills will be installed, one often has to rely on data from a meteo-station or airport quite far away. Roughly it can be said that when no major obstacles occur (mountains) and both places be-

long to the same climatological area the geographical variation in the wind speed will not be very large. At least the data obtained from the nearest station will give an indication about the wind potential in the area. A better impression can be obtained with short period on-site measurements with which the degree of correlation between the site and a nearby established wind speed recording station's wind history can be determined.

The extent to which site wind patterns reflect regional patterns is the degree of correlation.

Traditional site evaluations show that in case a high degree of correlation exists, then on-site wind speeds may be projected into the future based on the nearby station's past windspeed records corrected by a constant factor.

The reliability of the data, depends largely on the way of observation. Meteo-stations are often situated near or close by cities and surrounded by buildings or trees. Moreover the wind speed is often observed at 2m height. The figures obtained in this way, will be far below the wind speed in an open area, where windmills will operate. Airports are always situated in open areas and the wind-measuring equipment is often placed on top of the air-traffic control building. Except for the difference in height of observation for which a correction has to be made, these data are proper for further analysis.

It is advisable not only to collect the data, when available, but also to see how the data are collected. Continuous observations by a recorder are much more reliable than momentaneous observations say once in every hour of the wind speed. The latter is no indication of the average hourly wind speed at all. However, if every hour a wind run indicator reading is taken, this provides also an hourly average.

7.3 Annual Wind Pattern

The annual wind pattern can provide some information about the variability of the average wind speed during a year. In this data the first indication can be found, whether the wind pattern coincides with the annual pattern of crop irrigation requirements.

Graphical presentation of the average wind pattern of Babatpur airport (Varanasi).

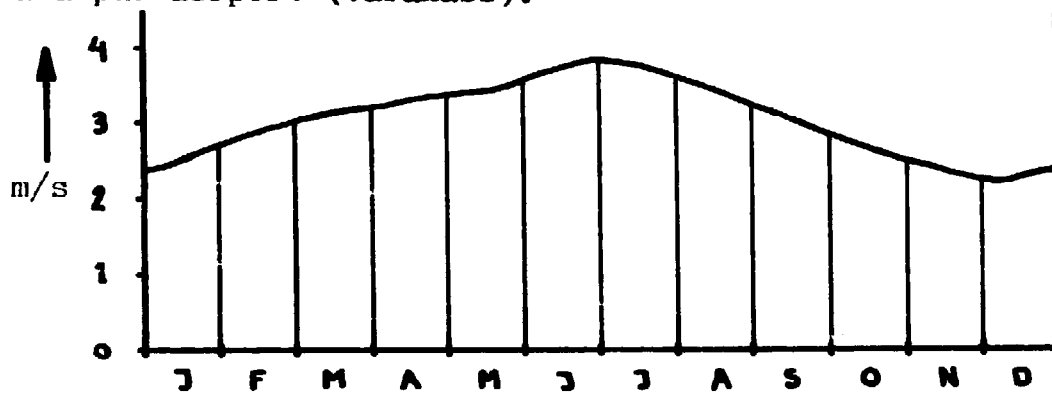

Here it can be seen that the period with highest wind speed coincides with the summer season, when a lot of irrigation water is required to grow a crop.

7.4 Diurnal Wind Pattern

The diurnal wind pattern is the wind speed distribution during the day. On the next page the diurnal pattern for every month of the year can be found, derived from data from Babatpur Airport (Varanasi). From this type of curves it can be found on the average at what periods of the day, the windmill will run and when the peak output can be expected. This is an indication whether the windmill output coincides with the daily requirement and if not what capacity the storage tank has to have to store the water pumped during night time for example.

Since the annual windspeed pattern as well as the diurnal

Mean diurnal wind pattern for each month based on hourly readings of a wind run anemometer at Babatpur.

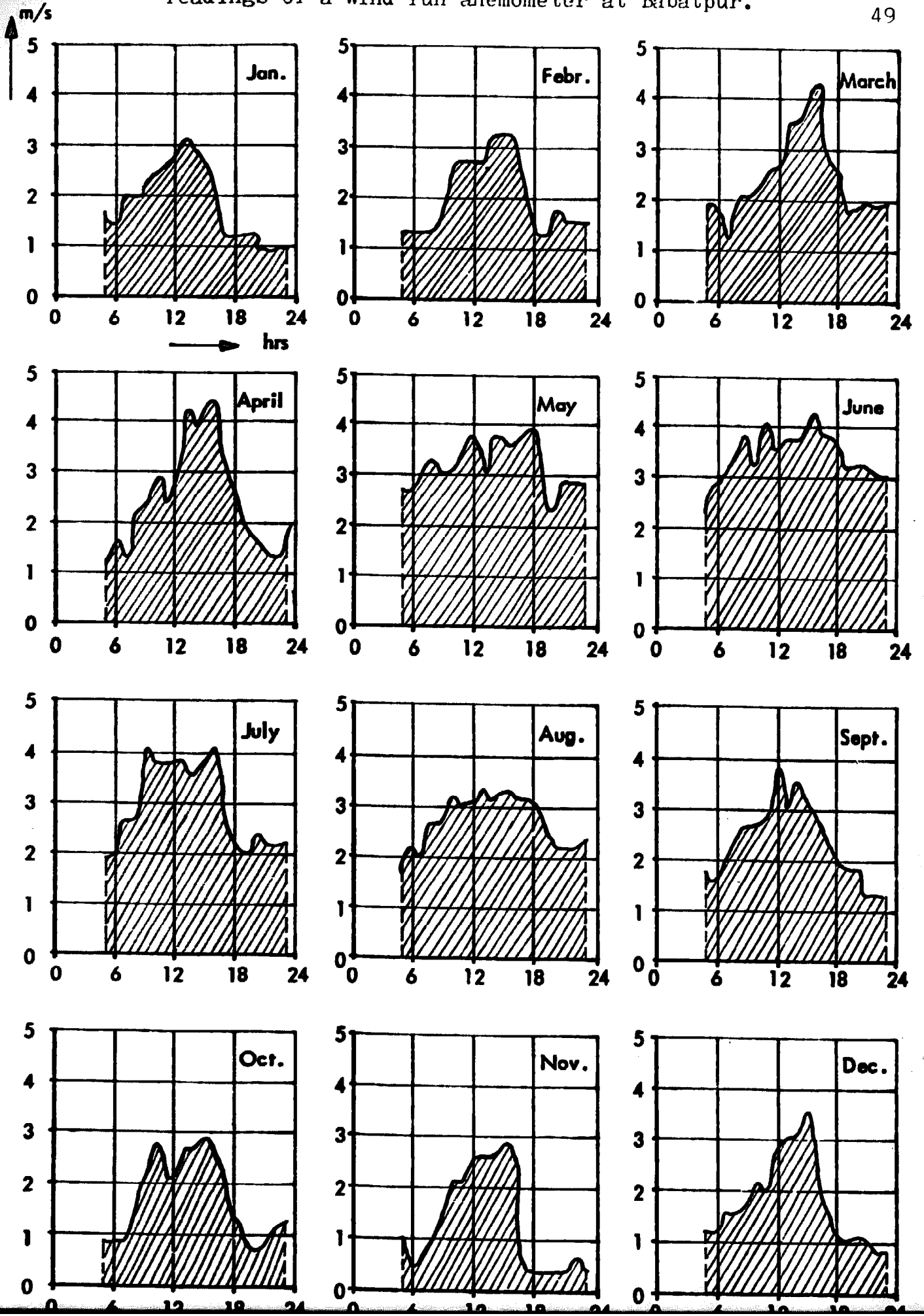

pattern are average figures it is not possible to derive from them the capacity of a windmill pump system.

To estimate the real amount of energy which can be extracted from the wind, the frequency of occurrence of periods with a certain wind speed has to be counted. With this we will deal in detail below. However, we will first study the maximum wind speed figures.

7.5 Maximum wind speed

The maximum wind speeds are important for the strength calculation of the windmill structure and for the design of the security mechanism. If cyclones or other heavy storms occur in the area, proper protective measures have to be taken to minimize the chance of damage to the windmills.

Designing a structure which can withstand all possible wind speeds will be impossible and also costly. Again it is stated here that hourly average maximum wind speed figures give no indication of the real peak gusts which may occur during a few seconds, but can be very destructive.

7.6 Windspeed frequency distribution

The wind speed frequency distribution is the most important wind characteristic for optimal windmill design and for windmill output predictions and consequently for windmill economics.

Hourly average wind speeds are the minimum requirement for this approach. On the next page one example has been given in what way the data have to be processed to derive this frequency distribution.

RECORDED WINDSPEED

Year : 1978
 Month: May
 Day : 17 th

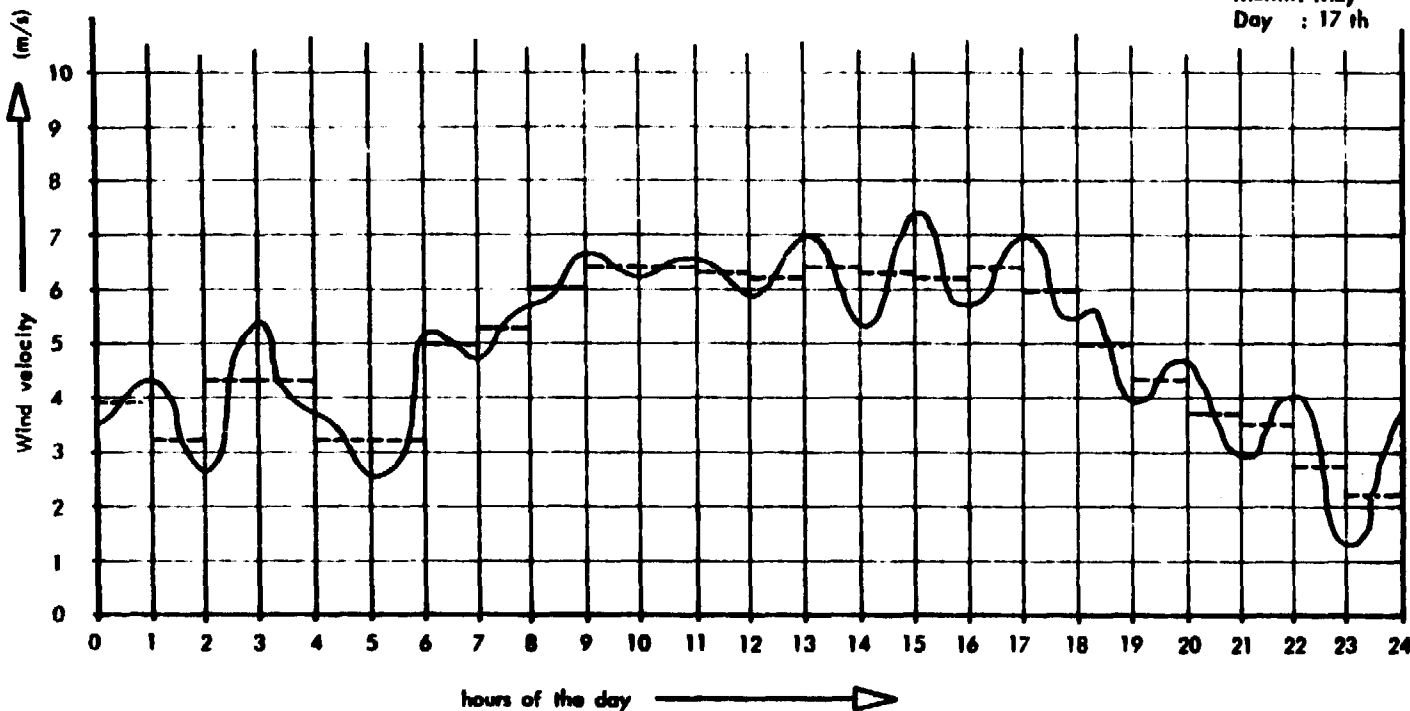

First the hourly average is calculated out of the recorder readings, from the observation station.

These hourly averages are collected in a table as shown below. From this table which contains all the hourly averages of one month, also the hourly mean, daily mean and monthly mean can be derived.

Month : May 1978

		Hours																								daily mean		
		1	2	3	4	5	6	7	8	9	10	11	12	13	14	15	16	17	18	19	20	21	22	23	24			
Days	1																											
	12	3.2	3.9	3.9	3.0	2.7	2.6	2.9	2.9	2.2	1.1	1.3	1.0	1.8	2.2	1.3	0.9	1.7	1.7	1.9	2.5	2.9	2.4	3.0	3.9	2.4	2.4	
	13	4.2	4.3	5.0	3.9	3.6	4.2	3.6	3.2	2.9	2.1	2.4	3.2	3.2	2.9	2.7	2.0	2.7	3.6	2.0	2.0	3.0	3.7	2.3	1.9	3.1	3.1	
	14	2.1	1.4	0.6	0.7	1.2	1.4	-	1.4	1.4	2.2	2.3	4.0	4.3	4.5	4.5	4.2	4.0	3.6	3.0	2.4	2.2	2.3	2.4	2.9	2.9	2.9	
	15	2.4	2.2	1.1	0.9	0.4	1.0	1.1	2.0	2.9	2.4	1.4	1.4	1.4	2.2	1.9	1.9	2.1	1.4	1.0	0.7	1.2	2.9	3.0	2.9	1.7	1.7	
	16	3.0	2.5	2.2	2.6	2.9	2.7	4.3	4.8	5.0	5.0	5.0	5.3	5.2	5.2	5.0	5.2	5.1	5.2	4.3	2.8	3.5	4.0	4.3	4.3	4.1	4.1	
	17	3.9	3.2	4.3	4.3	3.2	3.2	5.0	5.3	6.0	6.4	6.4	6.3	6.2	6.4	6.3	6.2	6.4	6.0	5.0	4.3	3.7	3.5	2.7	2.2	4.9	4.9	
	31																											
	hourly mean	3.1	2.9	2.9	2.6	2.3	2.5	3.4	3.5	3.4	3.2	3.1	3.5	3.7	3.9	3.6	3.4	3.7	3.6	2.9	2.5	2.8	3.1	3.0	3.0	3.1	3.1	
																												monthly mean

Secondly the occurrence of wind speeds in each range of wind velocities with the intervals of 1 m/s are counted and collected as shown on the following table.

Month : May 1978

windspeed range m/s	frequencies	In hours	In percentages
12 - 10			
11 - 10.9			
10 - 10.9			
9 - 9.9			
8 - 8.9			
7 - 7.9			
6 - 6.9		10	7
5 - 5.9		14	10
4 - 4.9		18	13
3 - 3.9		26	18
2 - 2.9		44	31
1 - 1.9		25	17
0 - 0.9		6	4
	total	143	100

This frequency distribution is visualized in the following Graph, a so-called histogram.

Windspeed frequency distribution

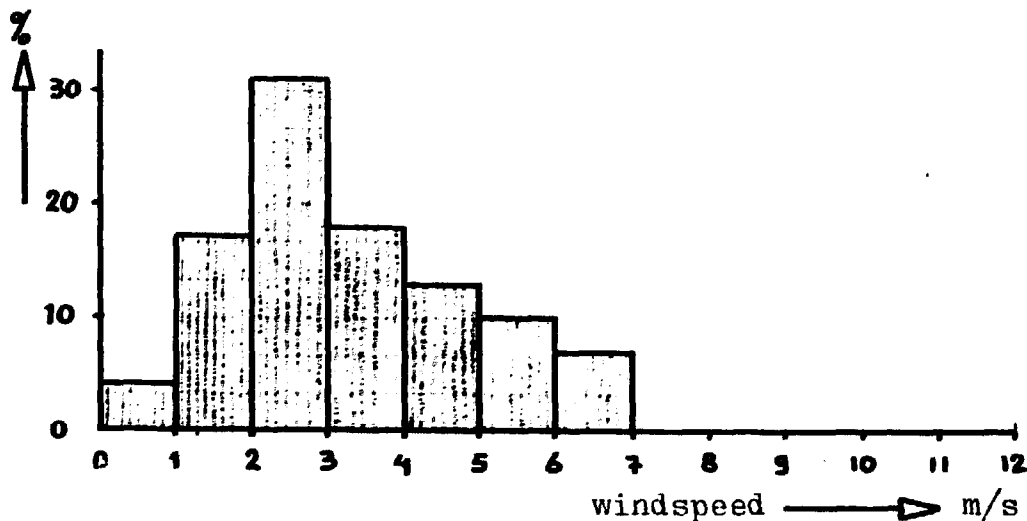

When this has been completed for every month of the year, these data need special observation to find the most optimal windmill pump system.

The design wind speed of the windmill is determined by the frequency distribution of the wind speed and the output characteristic of the windmill pump system.

7.7 Determining the design wind speed

The performance of the 12 PU windmills with a reciprocating single acting piston pump can be approximated by a graph as indicated below.

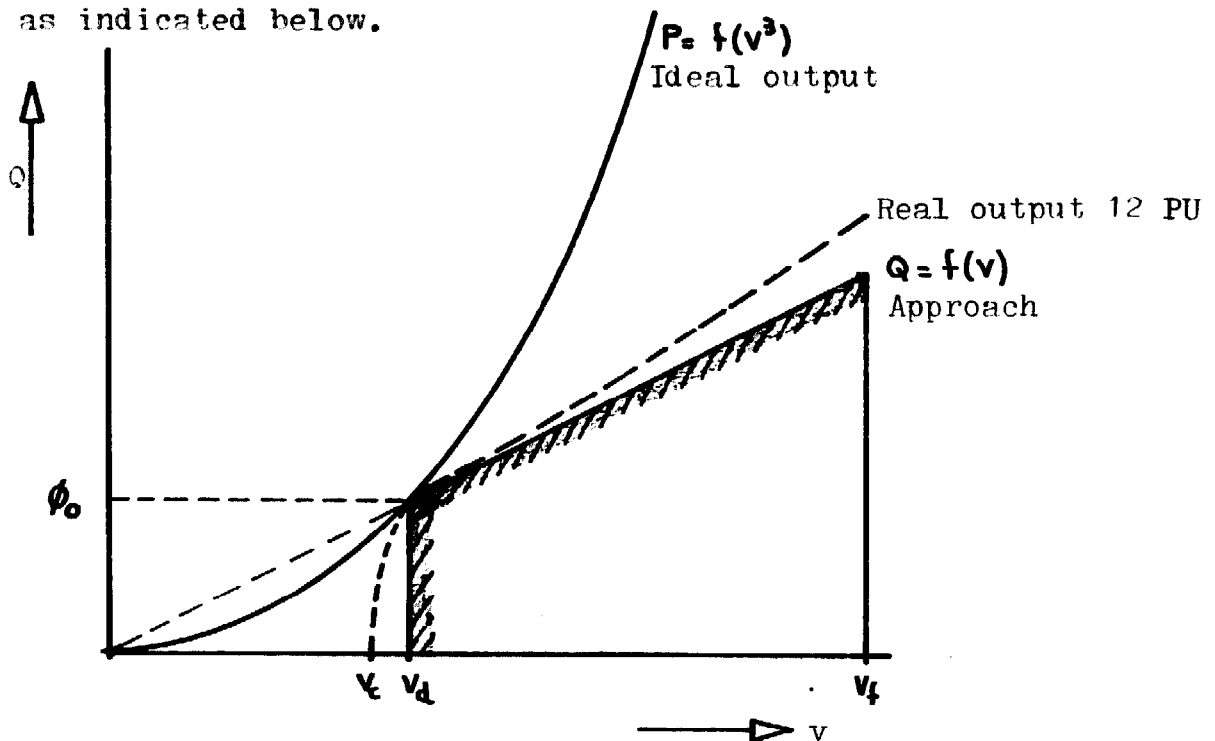

For $V = V_d$ we may write:

$$P_{\text{windmill}} = P_{\text{water}}$$

or:

$$\eta_{\text{tot}} \frac{1}{2} \rho V_d^3 A = \rho_w g H \phi_0$$

$$\phi_0 = \frac{\eta_{\text{tot}} \frac{1}{2} \rho V_d^3 A}{\rho_w g H} \quad (7.1)$$

For $V > V_d$ we may write:

(a straight line through the origin and the intersection of $V_d - \phi$)

$$\phi = \frac{\eta_{\text{tot}} \frac{1}{2} \rho V_d^2 A}{\rho_w g H} \cdot V \quad (7.2)$$

For the 12 PU windmill the overall efficiency (η_{tot}) at the design windspeed is 0.3

$$\begin{aligned} \text{With } \rho_w &= 1000 \text{ kg/m}^3 \\ g &= 9.8 \text{ m/s}^2 \\ \rho &= 1.2 \text{ kg/m}^3 \end{aligned}$$

we may write for (7.2) :

$$\phi = 1.84 \times 10^{-5} \frac{A}{H} \times V_d^2 \times V \quad [\text{m}^3/\text{s}] \quad (7.3)$$

The value of V_d will be optimal for the maximum of

$$Q = \int_{t_1}^{t_2} \phi dt \quad (7.4)$$

Substitution of 7.3 in 7.4 gives:

$$\begin{aligned} Q &= \int_{t_1}^{t_2} 1.84 \times 10^{-5} \frac{A}{H} \times V_d^2 \times v dt \\ Q &= 1.84 \times 10^{-5} \times \frac{A}{H} \times V_d^2 \int_{t_1}^{t_2} v dt \end{aligned} \quad (7.5)$$

In other words Q is maximal for $V_d^2 \int_{t_1}^{t_2} v dt = \text{maximal}$ (7.6)

With the wind speed frequency distribution it is easy to find this optimum, if we write (7.6) in the following way:

$$V_d^2 \int_{t_1}^{t_2} v dt \approx V_d^2 \sum_{t_1}^{t_2} V_i t_i \quad (7.7)$$

V_d = design wind speed

V_i = interval middle windvelocity

t_i = frequency of interval V_i

With the following example this procedure will be explained : (same example as before)

V	V _d	V _i	t _i	V _i t _i	$\sum_{t_1}^{t_2} V_i t_i$	V _d ²	V _d ² $\sum_{t_1}^{t_2} V_i t_i$
0 - 1	0	0.5	6	3	464.5	0	0
1 - 2	1	1.5	25	37.5	461.5	1	461.5
2 - 3	2	2.5	44	110	424	4	1696
3 - 4	3	3.5	26	91	314	9	2826
4 - 5	4	4.5	18	81	223	16	3568 ←
5 - 6	5	5.5	14	77	142	25	3550
6 - 7	6	6.5	10	65	65	36	2340
7 - 8	7	7.5	-	-	-		
8 - 9	8	8.5	-	-	-		
9 - 10	9	9.5	-	-	-		
10 - 11	10	10.5	-	-	-		

From the last column can be seen that the maximum value for Q is reached for V_d of 4 m/s; or better that the design wind speed should preferably lie between 4 and 5 m/s in order to achieve a maximum output for the given frequency distribution.

It is stressed here that the optimal wind speed over the year can vary considerably. The design speed should be chosen in such a way that the maximum obtainable output will be reached during the critical months.

To obtain also optimal outputs during months with lower wind speeds the stroke of the pump can be reduced by reducing the acting crank arm.

Experiences reveal that it is more important for the introduction of the windmill that the windmill works and pumps at least something, than when it only works during a few hours of the week.

If a regular water supply is regarded to be more important than maximizing the water yields, the design wind speed should be chosen at a lower value, for example from 3 to 4 m/s.

In case of the example used here with a chosen design speed of 4.5 m/s the windmill will run only 23% of the time. With a design speed of 3.5 m/s the windmill will run 38% of the time with an approx. 20% reduced output.

The frequency of wind speeds of 10 m/s and more should not be taken into account in determining the optimal design speed since the windmill will be in secured position at those wind speeds.

Concluding we may say that the maximum obtainable output is not the only main objective.

Also the running percentage has to be considered in connection with the required regularity of water supply and for psychological acceptance of the windmill.

8. WINDMILL OUTPUT CALCULATIONS

If the input-output relation of a certain windmill is known, the total quantity of water which can be pumped during a certain period can be calculated with the help of the wind speed frequency distributions. This is, however, only valid for one combination of pump-size, total head and design wind speed.

The theoretical output can be calculated with (7.5) and (7.7) for a windmill of the 12 PU serie:

$$Q = 1.84 \cdot 10^{-5} \frac{A}{H} v_d^2 \sum_{t_1}^{t_2} v_i \cdot t_i$$

For t_i in hours instead of seconds this relation becomes:

$$Q = 6.624 \cdot 10^{-2} \frac{A}{H} \cdot v_d^2 \sum_{t_1}^{t_2} v_i t_i \quad (8.1)$$

The term $v_d^2 \sum_{t_1}^{t_2} v_i t_i$ is calculated in the table of chapter 7.7.

as 3568 for a v_d of 4 m/s.

So the theoretical output during the period observed with a 12 PU 500 windmill and a total head of 6 m will be:

$$Q = 6.624 \cdot 10^{-2} \cdot \frac{\pi \cdot 2.5^2}{5} \cdot 3568$$

$$Q = 928 \text{ m}^3$$

In practice however, this value will be always more or less lower due to restrictions in the number of different diameters of the standardized pumps. One can make a choice out of 3", 4", 5", 6" and 8" diameter cylinders. A windmill with an oversized pump results in a higher design speed and

consequently in a lower output (and fewer running hours). On the other hand a windmill with an undersized pump will result in a lower design speed and consequently in a lower output (but more running hours).

In chapter 9 determining the diameter of the pump will be dealt with.

Also variation in ground water table (or other water source) will influence the design wind speed and consequently the output.

Often there is a positive correlation between a receding water table in summer season and an increasing wind speed. The effect of increasing wind speed is quite often even sufficient to compensate not only the increased lifting head, but also to meet the higher water demand during summer season.

These three effects have to be taken into account in determining the most critical month(s).

Comparison of theoretically calculated outputs and the actual windmill outputs revealed a difference of about 30%. The actual output being 70% of the calculated output. This ratio is called the working efficiency of the windmill and is estimated to be about 70%.

It is due to the fact that the windmill will work a less number of hours than theoretically possible due to maintenance, breakdowns or being left in secured position (semi-automatic security mechanism) (v. Vilsteren 1979) and due to fluctuations in wind speed and changing wind directions.

Finally it will be clear that wind data of one year can not provide sufficient reliable information concerning future wind energy potential. At least 5 to 10 years of data have to be worked out to find reliable data by means of averages and probability analyses.

Although collecting 5 to 10 years of on-site wind data, while extremely desirable in terms of providing high quality data, would most likely be prohibitively expen-

8.1 Correction factor for difference in height

The height of the rotor shaft above ground level is seldom the same as the height at which the windspeeds are recorded. Hence a correction factor has to be applied for the wind speeds "seen" by the windmill rotor since the actual wind speed is depending on the height at which it is considered.

The friction between the lowest layer of the atmosphere and the earth is largely determined by the roughness of the earth's surface. A smooth surface like that of a beach will have little effect upon the wind speeds in the layer above, but a rough surface, like a city, has a strong effect.

A secondary effect is the stability of the atmosphere. One can imagine that the turbulent exchange is much higher in an unstable atmosphere, with the result that higher wind speeds in upper layers more easily can reach the surface. This effect becomes smaller, however, when the wind speeds are higher. Because we are mostly interested in higher wind speeds, for wind energy purposes we will neglect this effect.

Generally, meteorologists have adopted a logarithmic profile to describe the increase in average wind speed with increasing height above the roughness elements.

Usually one wishes to determine the wind speed at a height H_2 when the wind speed at a height H_1 is given.

The expression therefore is:

$$\frac{v_{H2}}{v_{H1}} = \frac{\ln \frac{H2}{z_0}}{\ln \frac{H1}{z_0}} \quad (8.1)$$

z_0 is the roughness height.

This assumes, however, that the roughness heights at both places are the same.

When the roughness heights differ, then we need a reference height where we can assume that the wind speed is not much affected by the roughness. This reference height is often

determined as 60 m (above the roughness elements).

The formula then becomes:

$$\frac{v_{H2}}{v_{H1}} = \frac{\ln \frac{60}{z_{01}} \times \ln \frac{H2}{z_{02}}}{\ln \frac{60}{z_{02}} \times \ln \frac{H1}{z_{01}}} \quad (8.2)$$

When the roughness heights are the same (8.2) reduces to (8.1).

The roughness heights are difficult to determine.

A number of values of z_0 for typical terrain types is given in the following table.

Terrain description of area within several kilometres upwind of site	z_0 m
smooth surface, open sea, desert (flat)	0.001
low grass, flat open terrain	0.008
high grass, airports (runway area)	0.02
farmland, isolated trees, small crops	0.03
farmland, many hedges, tall crops	0.08
many trees, hedges, few buildings	0.2
small towns, suburbs	0.6

The international accepted standard height for taking wind data is 10 m.

We will make a calculation example for the following situation. wind speed recordings have been obtained from an airport with a cup anemometer at 17.2 m above ground level ($H2 = 17.2$ m). In case of applying a windmill with a rotor height of $H1 = 7$ m above groundlevel situated in farmland with tall crops, we may take the following roughness heights according the table for the airport $z_{02} = 0.02$ m and for the windmill site $z_{01} = 0.08$ m.

The correction factor will become:

$$C = \frac{v_{H1}}{v_{H2}} = \frac{\ln \frac{60}{z_{o2}} \times \ln \frac{H1}{z_{o1}}}{\ln \frac{60}{z_{o1}} \times \ln \frac{H2}{z_{o2}}}$$

$$C = \frac{\ln \frac{60}{0.02} \times \ln \frac{7}{0.08}}{\ln \frac{60}{0.08} \times \ln \frac{17.2}{0.02}} = 0.80$$

So the wind speed at rotor height is 80 % of that at measuring height.

It can also be seen here that increasing the height of the windmill (tower) will have a positive effect on the power which will be generated, but a negative one with regard to the cost price of the tower as we have seen already in chapter 6.3.

9. DETERMINING PUMP DIAMETER

In order to determine the diameter of the pump (cylinder) one has to know the total head over which the pump has to lift the water and the design wind speed, which resulted from the wind speed analyses (see chapter 7.7).

For $V = V_d$ we may write (see 7.7)

$$P_{\text{windmill}} = P_{\text{water}}$$

$$\frac{1}{2} \rho V_d^3 \pi R^2 \cdot \eta_{\text{tot}} = \rho_w \cdot g \cdot H \cdot V_s \cdot n \cdot \eta_v \quad (9.1)$$

where:

- ρ = air density = 1.2 kg/m³
- V_d = design speed [m/s]
- R = Rotor radius [m]
- ρ_w = density of water = 1000 kg/m³
- g = acceleration of gravity = 9.8 m/s²
- H = lifting head [m]
- n = number of revolutions [rev/s]
- V_s = stroke volume [m³]
- η_{tot} = total efficiency
- η_v = volumetric efficiency

For the number of revolutions of the pump we may write at $V = V_d$:

$$n = \frac{\lambda \cdot V_d}{2 \pi R} \quad (9.2)$$

and for stroke volume of the pump

$$V_s = \frac{1}{4} \pi d^2 \times s \quad (9.3)$$

where: s = stroke of the pump [m]
 d = diameter of the cylinder [m]

Substitution of (9.2) and (9.3) in (9.1) results in:

$$d^2 = 4 \frac{\rho}{\rho_w} \cdot \frac{\pi}{g} \cdot \frac{R^3}{H} \cdot \frac{\eta_{\text{tot}}}{\eta_v} \cdot \frac{V_d^2}{s \cdot \lambda} \quad (9.4)$$

For the 12 PU series we write for:

$$\begin{aligned}\lambda &= 2 \\ \eta_{\text{tot}} &= 0.30 \\ \eta_v &= 0.85\end{aligned}$$

So that (9.4) becomes:

$$d = 0.0165 V_d \sqrt{\frac{R^3}{H \cdot s}} \quad (9.5)$$

and for the 12 PU 500 with $R = 2.5$ m

$$d = \frac{0.065 V_d}{\sqrt{H \cdot s}} \quad (9.6)$$

For the example which was taken in 7.7 we found a design wind speed of 4 - 5 m/s, say 4.5 m/s.

So for an elevation head of 6 m (which was taken in the example of 8) we find for the diameter of the pump, for a stroke of 0.24 m:

$$d = \frac{0.065 \times 4.5}{\sqrt{6 \times 0.24}} = 0.24 \text{ m}$$

If, however, the design speed is chosen lower, say 3 m/s, for reasons mentioned in 7.7 the diameter will become:

$$d = \frac{0.065 \times 3}{\sqrt{6 \times 0.24}} = 0.163 \text{ m}$$

This results obviously in a 6" "standard" pump, with a herewith belonging design wind speed of

$$0.15 = \frac{0.065 \times V_d}{\sqrt{6 \times 0.24}} \quad \Rightarrow \quad V_d = 2.8 \text{ m/s}$$

If this pump (6") is coupled to the windmill then the expected output will follow from the table of 7.7.

The term $V_d^2 \sum_{t_1}^{t_2} V_i t_i$ is for 3 m/s: 2826, so with

expression 8.1 the output during the observed period in the example will be: 612 m³.

This is 34% less than the theoretical optimum, but the number of running hours is increased from 23% to 48% of the total time and so a more regular delivery is obtained.

10. MEASURING OF WINDMILL PUMP PERFORMANCE

After the windmill has been designed, constructed and installed, it is interesting to see, whether the windmill performs accordingly the design parameters like tip speed ratio, design wind speed and efficiency and if not, what changes have to be made to improve the performance. The parameters which can be measured directly at the windmill pump system are wind speed, R.P.M. and output. Other parameters, like λ and η can be derived from those data.

There are in principle two types of measuring methods which can be applied.

One method is measuring during a large number of very short periods (up to 10 seconds) during which the wind speed and wind direction are constant.

These periods of constant wind speed are easy to recognize since a small variation in wind speed will result in an also small variation of number of revolution.

These changes in R.P.M. are audible very well.

The aim of this measuring method is to determine the tip speed - wind speed relation, efficiency - wind speed relation and the discharge - wind speed relation.

Another method is measuring during longer periods: preferably 1 hour periods, which give more insight in the average performance of the windmill-pump system. Against hourly average wind speeds the hourly output is determined. This relation is more useful in output predictions since all losses caused by fluctuating wind speed and changing wind directions are included. Moreover, most wind data are also presented as hourly averages.

10.1 momentaneous measuring method

The minimum equipment required for this method is:

- windvelocity meter
- chronometer (stopwatch)
- small drum of about 20 l with measuring scale
- measuring tape to measure the elevation head

Due to variation in wind speed, over short distance as well as over short periods, it is essential to have the windvelocity meter installed close by the rotor and in the same plane as the rotor. This will minimalize the difference of wind speed felt by the wind wheel and the cupanemometer.

Accurateness is required because an error in wind speed reading will for instance in calculating the power conversion efficiency result in a deviation which is proportional to the cube of this error

For measuring the amount of water pumped during the clocked period a 20 litre drum is held under the outlet of the delivery pipe during 4 or 5 strokes. The drum is put under the delivery during the downward movement of the piston when no water is being delivered. At the same time the chronometer is started and the strokes are counted. After 4 or 5 strokes the drum is shifted from the delivery again during the downward movement of the piston. At the same time the chronometer is stopped and the reading is printed. During the measuring cycle also the wind speed is printed. This complete measuring cycle has to be carried out with a constant wind speed. If during the measuring period the wind speed changes, which is very well detectable, the measuring cycle can be cancelled right away and a new cycle can be started.

In case the wind speed increases during the measuring period, part of the available wind energy is used for accelerating the windmill-pump system, so it is not known how much energy is utilized for lifting the amount of water measured.

If on the other hand the wind speed decreases during the measuring period, not only the available wind energy is used for lifting the water, but also part of the energy

stored in the windmill system, which will be released by decelerating the windmill-pump system, so also here it is not known how much energy is utilized for lifting the amount of water measured. That is why only under stationary conditions measurements should be carried out, in order to obtain reliable data.

Screening of the data, i.e. selecting only the proper readings according certain suppositions, will become easier if sufficient readings have been taken.

On the next page a measuring form can be seen.

On the windmill site the headings and the first four columns are filled. At the office the other columns can be processed.

R.P.M. can be found by the following formula:

$$\frac{\text{number of revolutions}}{\text{time interval [s]}} \times 60 = [\text{R.P.M.}]$$

The water flow can be found by:

$$\frac{\text{discharge [litres]}}{\text{time interval [s]}} = [1/\text{s}]$$

The volumetric efficiency (η_v) is defined as:

$$\frac{\text{discharge / stroke}}{\text{stroke volume}} = \frac{\text{discharge}}{\pi/4 d^2 s \cdot \text{number of revolutions}}$$

If the discharge is given in litres the diameter and the stroke of the pump should be noted in dm.

The tip speed ratio (λ) can be derived as follows

$$\lambda = \frac{2\pi n R}{v} = \frac{2\pi R \cdot \text{number of revolutions}}{\text{wind speed} \cdot \text{time interval}}$$

R = rotor radius [m]

Finally the total power conversion efficiency ($C_p \cdot \eta_{tot}$) is calculated as follows:

$$C_p \cdot \eta_{tot} = \frac{P_{mech}}{\frac{1}{2} \rho v^3 \pi R^2} \times \frac{Q_w \cdot g \cdot H \cdot Q}{P_{mech}}$$

$$C_p \cdot \eta_{tot} = \frac{Q_w \cdot g \cdot H \cdot Q}{\frac{1}{2} \rho v^3 \pi R^2}$$

Plotting the calculated data in graphs will give a clear picture of the relations.

Screening the data will be easier if they are rearranged with an increasing windspeed sequence. Screening itself is a little tricky, because one tends to cancel all strong deviating measuring points.

However, wrong measurements can be detected from the wind speed - RPM relation. In general RPM should increase with increasing wind speeds. If that is the general tendency of the measuring points, then flukes are to be imputed to acceleration or deceleration effects so these measuring points should be omitted.

From the graphs and the table the following design values can be checked:

- The wind speed at which the windmill-pump system works optimal (with its highest efficiency) should be in accordance with the design speed of the installation.
- The tipspeed-ratio should be according to the design value at the design wind speed.
- The volumetric efficiency of the pump should have reasonable values (not below 70%).
- The input - output ($v - Q$) relation should be acceptable.

On the following pages an example has been presented.

WINDMILL PERFORMANCE MEASURING FORM

Site: Total Elevationhead: 4.5 m
 Date: Pump stroke: 0.24 m
 Executors: Piston diameter: 0.15 m
 Windmill type: 1.5 PU 500

Serial Number	Windspeed reading m/s	Time interval (sec)	Number of rev.	Discharge (liters)	RPM	Q (l/sec)	vol. eff.	tip speed ratio	System efficiency
1	2.5	8.4	4	13.5	29	1.6	0.80	2.99	0.49
2*	2.7	6.1	4	14.5	39	2.4	0.85	3.81	0.59
3	2.9	6.6	4	13.5	36	2.0	0.80	3.28	0.39
4	2.9	9.4	4	10.5	26	1.1	0.62	2.30	0.22
5*	3.1	6.0	4	13.5	40	2.3	0.80	3.38	0.37
6	3.2	7.5	4	12.0	32	1.6	0.71	2.62	0.23
7	3.2	7.9	4	12.0	30	1.5	0.71	2.49	0.22
8	3.6	6.5	4	12.5	37	1.9	0.74	2.69	0.20
9	3.6	7.2	4	14.0	33	1.9	0.83	2.42	0.20
10	4.0	7.6	4	11.5	32	1.5	0.68	2.07	0.11
11	4.0	6.0	4	14.5	40	2.4	0.85	2.62	0.18
12*	4.3	4.5	4	14.5	53	3.2	0.85	3.25	0.19
13	4.3	6.2	4	13.5	39	2.2	0.80	2.36	0.13
14	4.6	5.8	4	13.0	41	2.2	0.77	2.35	0.11
15	5.2	5.5	4	14.5	44	2.6	0.85	2.20	0.10
16	5.2	5.5	4	13.5	44	2.5	0.80	2.20	0.09
17	5.2	4.8	4	14.0	50	2.9	0.83	2.52	0.10
18*	5.9	3.2	4	15.0	75	4.7	0.88	3.33	0.11
19	6.0	5.0	4	14.0	48	2.8	0.83	2.09	0.06
20	6.2	3.8	4	15.0	63	3.9	0.88	2.67	0.08
21*	6.5	5.0	4	15.5	48	3.1	0.91	1.93	0.05
22	6.5	4.0	4	15.5	60	3.9	0.91	2.42	0.07
23*	6.5	3.2	4	15.0	75	4.7	0.88	3.02	0.08
24	7.2	3.2	4	14.4	75	4.5	0.85	2.73	0.06
25	7.2	3.2	4	15.5	75	4.8	0.91	2.73	0.06
26*	7.2	3.4	4	14.0	71	4.1	0.83	2.57	0.06
27	7.9	3.1	4	15.5	77	5.0	0.91	2.57	0.05
28	8.3	3.1	4	15.5	77	5.0	0.91	2.44	0.04

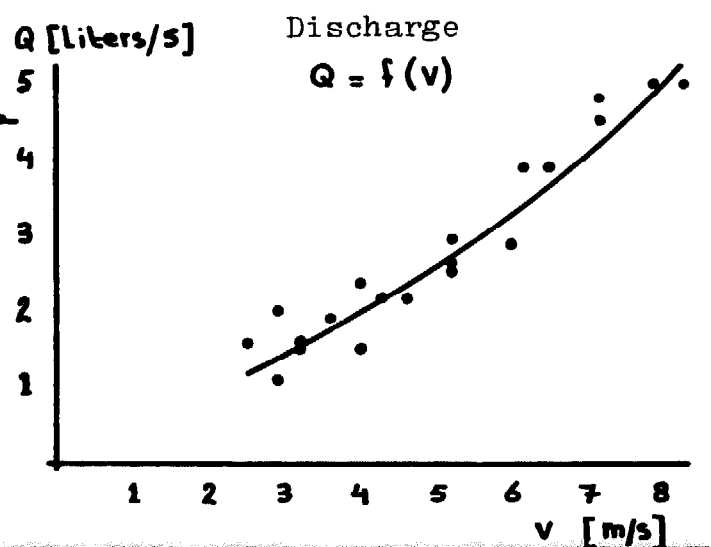
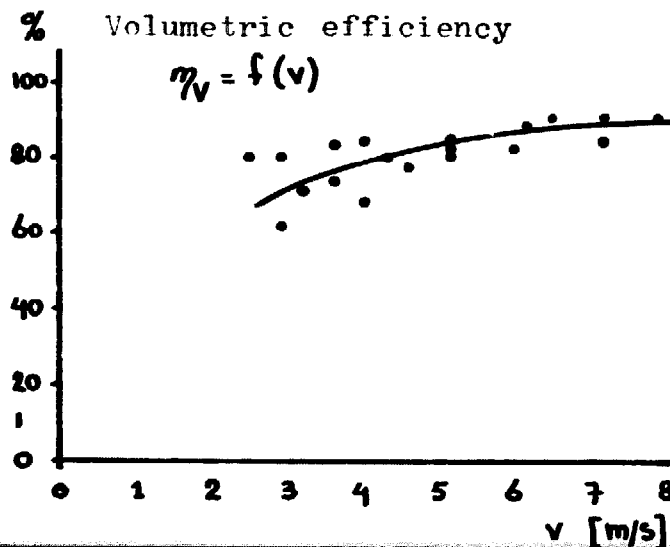
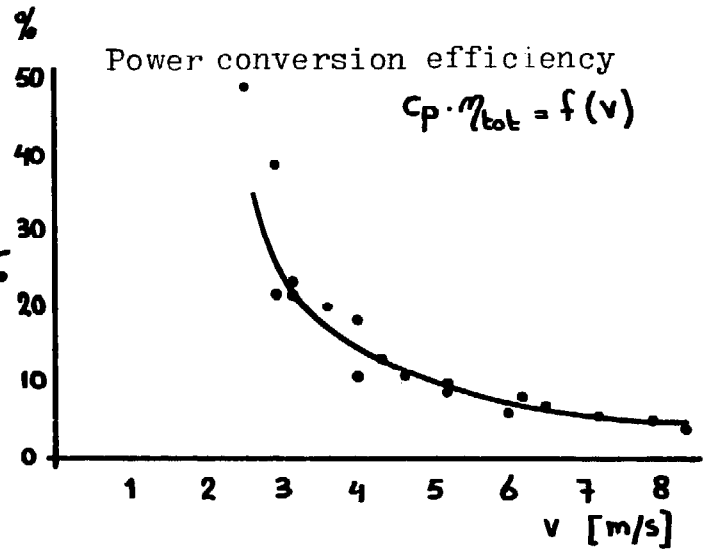
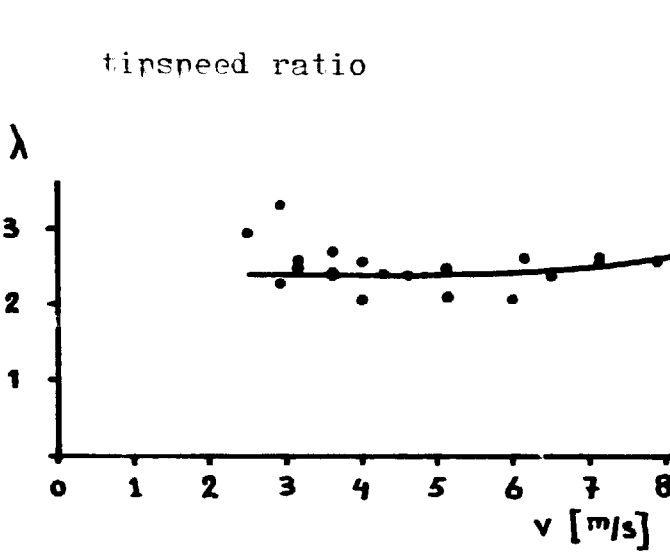
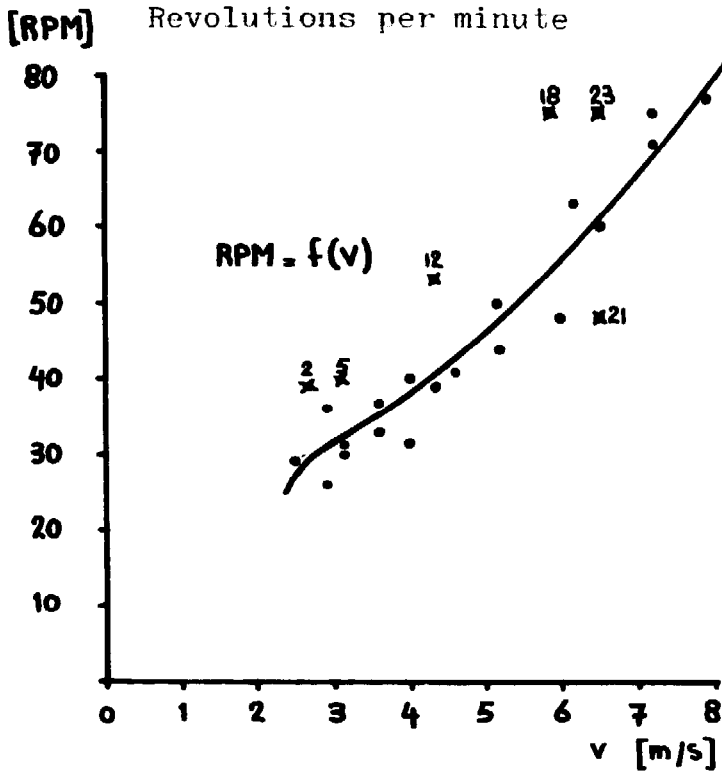

10.2 Continuous measuring method

For this method it is very convenient to have a 2 - channel measuring recorder which registrates hourly average wind speeds and hourly water discharges simultaneously.

From this recordings the relation between hourly average wind velocity and output can be derived.

With this measuring method it is also easy to compare the generated power (in terms of pumped quantities of water over a uniform head) per square metre swept area as a function of the wind speed of various windmills.

The power per m^2 is calculated with:

$$P = \frac{\rho_w g \cdot H \cdot Q}{\pi R^2} \quad \left[\text{Watt}/m^2 \right] \quad (10.1)$$

references

- E.W. Golding - The generation of electricity by windpower.
London, 1976
- N.G. Calvert - Wind power principles :
their application on the small
scale.
1979
- Steve Blake - Site Selection and evaluation
handbook for windenergy systems.
1979
- A.E.M. van Vilsteren - Wind data analyses and performance
of the 12 PU 500 windmill at
Ghazipur. Report no. 4 TOOL - ORP
windmill project
June 1979, TOOL - Amsterdam
- W.A.M. Jansen and
P.T. Smulders - Rotor design for horizontal axis
windmills.
May 1977, SWD - Amersfoort
- J. Beurskens, M.Houet,
P. van der Varst - Windenergie, diktaat no. 3.323
april 1974, T.H. Eindhoven
- N.J. van de Ven - Technical report,
March 1982, TOOL/WOT - Amsterdam

λ_r	ϕ	$(1-\cos\phi)$
10.00	3.807	0.00220
9.75	3.904	0.00232
9.50	4.006	0.00244
9.25	4.113	0.00258
9.00	4.227	0.00272
8.75	4.347	0.00288
8.50	4.473	0.00305
8.25	4.607	0.00323
8.00	4.750	0.00343
7.75	4.902	0.00368
7.50	5.063	0.00390
7.25	5.236	0.00417
7.00	5.420	0.00447
6.75	5.618	0.00480
6.50	5.831	0.00517
6.25	6.060	0.00559
6.00	6.308	0.00605
5.75	6.577	0.00658
5.50	6.870	0.00718
5.25	7.190	0.00786
5.00	7.540	0.00865
4.75	7.926	0.00955
4.50	8.353	0.01061
4.25	8.827	0.01184
4.00	9.357	0.01336
3.75	9.954	0.01505
3.50	10.630	0.01716
3.25	11.402	0.01974
3.00	12.290	0.02292
2.75	13.322	0.02691
2.50	14.534	0.03200
2.25	15.975	0.03862
2.00	17.710	0.04739
1.75	19.830	0.05930
1.50	22.460	0.07585
1.25	25.773	0.09948
1.00	30.000	0.13397
0.75	35.420	0.18507
0.50	42.290	0.26025
0.25	50.642	0.36584
0.00	60.000	0.5

$$\lambda_r = \frac{\sin\phi (2 \cos\phi - 1)}{(1-\cos\phi) (2\cos\phi + 1)} = \cotan \frac{3}{2} \phi$$

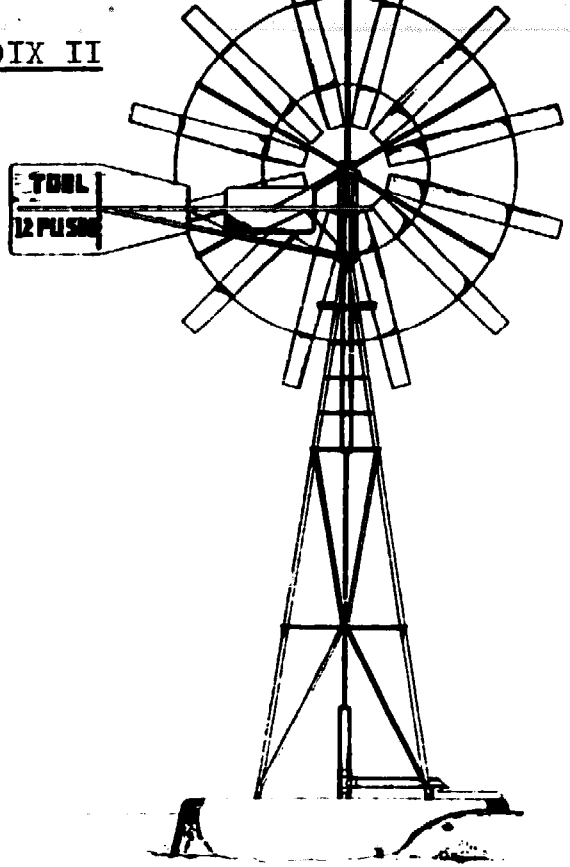

Rotor

diameter: 5 m
 number of blades: 12
 design of blades: 10% arched steel sheet
 tip speed ratio: 2
 maximum power coefficient: .38

Transmission

crank - connecting rod - crosshead system
 crank radii: .06, .09 and .12 m.

Security system

automatic system. Rotor is turned out of the wind by indication of auxiliary vane

Cut-in wind speed

depending on wind regiem

Pump

various diameters 3", 4", 5", 6" and 8"
 depending on elevation head and wind regiem
 Single acting reciprocating piston pump with centrally positioned internal airchambers

Tower

4 leg lattice tower with standard height of 7 m.

Materials

2 sizes of angle iron, 1 size of flat, common bolts, nuts, washers etc. ballbearings, nylon or bronze bushes, 1mm sheetmetal and wood

Total weight approx. 450 kg

Output see graphs

Price indication \$ 1000 (Indian conditions)

- Status
- first prototype has been built in 1977
 - further action research in 1978 with a dozen of these windmills in India
 - since 1980 hundreds of these windmills have been built
 - drawings, building manual and technical report available.

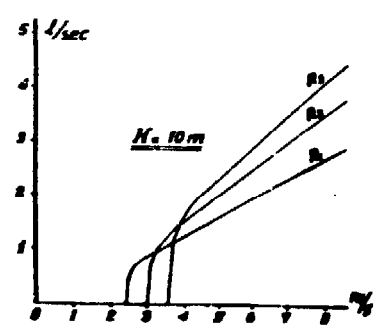
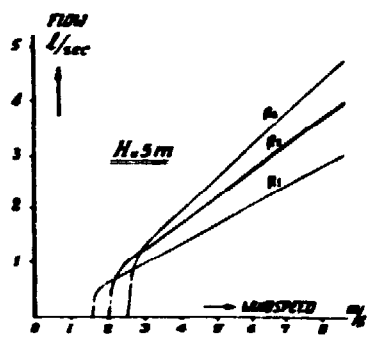

H - ELEVATION HEAD
 R₁ - 60 mm } CRANK RADIUS
 R₂ - 90 mm }
 R₃ - 120 mm }
 FOR 150 mm PISTON PUMP