

AT MICROFICHE
REFERENCE
LIBRARY

A project of Volunteers in Asia

Microhydropower Handbook, Volume 2

by EG&G Idaho for the U.S. Dept. of Energy

Published by:

National Technical Information Service (NTIS)
5285 Port Royal Road
Springfield, Virginia 22161
USA

Available from:

same as above

Reproduced by permission.

Reproduction of this microfiche document in any form is subject to the same restrictions as those of the original document.

MICROHYDROPOWER HANDBOOK: VOLUME 2

EG&G Idaho, Incorporated
Idaho Falls, ID

Jan 83

U.S. DEPARTMENT OF COMMERCE
National Technical Information Service

NTIS[®]

MICROHYDROPOWER HANDBOOK
Volume 2

J. D. McKinney, EG&G Idaho
Prof. C. C. Warnick, University of Idaho
B. Bradley, Braley Engineering
J. Dodds, EG&G Idaho
T. B. McLaughlin, EG&G Idaho
C. L. Miller, EG&G Idaho
G. N. Rinehart, EG&G Idaho
G. L. Sommers, EG&G Idaho

Published January 1983

EG&G Idaho, Inc.
Idaho Falls, Idaho 83415

Prepared for the
U.S. Department of Energy
Idaho Operations Office
Under DoE Contract No. DE-AC07-76ID01570

Published by the
Technical Information Center
U.S. Department of Energy

REPRODUCED BY
NATIONAL TECHNICAL
INFORMATION SERVICE
U.S. DEPARTMENT OF COMMERCE
SPRINGFIELD, VA. 22161

DISCLAIMER

"This report was prepared as an account of work sponsored by an agency of the United States Government. Neither the United States Government nor any agency thereof, nor any of their employees, makes any warranty, express or implied, or assumes any legal liability or responsibility for the accuracy, completeness, or usefulness of any information, apparatus, product, or process disclosed, or represents that its use would not infringe privately owned rights. Reference herein to any specific commercial product, process, or service by trade name, trademark, manufacturer, or otherwise, does not necessarily constitute or imply its endorsement, recommendation, or favoring by the United States Government or any agency thereof. The views and opinions of authors expressed herein do not necessarily state or reflect those of the United States Government or any agency thereof."

This report has been reproduced directly from the best available copy.

Available from the National Technical Information Service, U. S. Department of Commerce, Springfield, Virginia 22161.

Codes are used for pricing all publications. The code is determined by the number of pages in the publication. Information pertaining to the pricing codes can be found in the current issues of the following publications, which are generally available in most libraries: *Energy Research Abstracts, (ERA)*; *Government Reports Announcements and Index (GRA and I)*; *Scientific and Technical Abstract Reports (STAR)*; and publication, NTIS-PR-360 available from (NTIS) at the above address.

ACKNOWLEDGMENTS

The authors would like to thank the following people and organizations for their contribution to this handbook:

A. Batra, C. Grube and E. Jewell of Centrac Associates, Inc.;
G. L. Smith of Appropriate Technology; and
J. Volkman of Intermountain Energy Systems

For supplying draft material for the handbook.

J. T. Parker, EG&G Idaho, technical writer; and
S. C. Hall, EG&G Idaho, illustrator.

Meinikheim Machines, Banks, Idaho; and
GSA International Corporation, Katonah, New York

For reviewing the handbook in draft form.

K. Grover of GSA International Corporation

Who supplied much practical design information, and whose
experience in the hydropower field is reflected throughout the
handbook.

APPENDIX A
TECHNICAL SUPPORT

A-1	DEVELOPMENT OF THE POWER EQUATION	A1-1
A-2	ESTIMATING MINIMUM STREAM FLOW	A2-1
A-3	RAINFALL RUNOFF CORRELATION	A3-1
A-4	STREAM FLOW PROJECTIONS WHERE A GAGE CORRELATION DOES NOT EXIST	A4-1
A-4.1	Category 1 Developers	A4-1
A-4.2	Category 2 Developers	A4-3
A-5	ECONOMIC ANALYSIS	A5-1
A-5.1	Capital Cost Estimation	A5-1
A-5.2	Revenue Estimation	A5-4
A-5.3	Operating Cost Estimation	A5-5
A-5.4	Depreciation	A5-6
A-5.5	Calculation of Mortgage Payments (Principal and Interest)	A5-7
A-5.6	Taxes	A5-10
A-5.7	Preparation of the Cash Flow Analysis	A5-11
A-5.8	Benefit-Cost Analysis	A5-12
A-5.9	Simple and Discounted Payback	A5-14
A-5.10	Sensitivity Analysis	A5-14
A-5.11	Alternative Energy Source	A5-15
A-6	ELECTRICAL THEORY	A6-1
A-6.1	Electrical Terminology	A6-1
A-6.2	Generator and Motor Terminology	A6-8
A-6.3	Generator Theory	A6-16
A-6.3.1	The Single-Phase Generator	A6-17
A-6.3.2	The Three-Phase Generator	A6-21

A-6.4	Synchronous and Induction Generators	A6-22
A-6.4.1	Synchronous Generators	A6-22
A-6.4.2	Voltage Regulation	A6-26
A-6.4.3	Induction Generators	A6-28
A-6.4.4	Power Factor of an Induction Generator	A6-29
A-6.5	Generator Voltage and Connections	A6-30
A-6.5.1	Single-Phase, Three-Wire System	A6-31
A-6.5.2	Three-Phase, Four-Wire Wye System	A6-31
A-6.5.3	Three-Phase, Three-Wire Delta System	A6-32
A-6.5.4	Three-Phase, Four-Wire Wye System	A6-32
A-6.6	Terminal Connections	A6-34
A-6.7	Nameplate Data	A6-34
A-6.8	Generator Heat and Insulation Ratings	A6-43
A-6.8.1	Generator Heat	A6-43
A-6.8.2	Insulation Rating	A6-43
A-7	TURBINE SETTING AND SPECIFIC SPEED	A7-1
A-7.1	Specific Speed	A7-1
A-7.2	Turbine Setting	A7-2

FIGURES

A1-1	Pool-to-pool head	A1-1
A1-2	Elevation, pressure, and velocity head	A1-3
A2-1	Estimating minimum stream flow	A2-2
A3-1	Hell Roaring Creek drainage basin and vicinity	A3-2
A3-2	Map of Hell Roaring Creek drainage basin	A3-3
A3-3	Flow duration curve for Pack River near Colburn	A3-10
A3-4	Flow duration curve for Q_i/Q_p	A3-14
A3-5	Flow duration curve for the proposed microhydropower site at the mouth of Hell Roaring Creek	A3-16
A5-1	Steps in the economic analysis procedure	A5-2
A6-1	Single-phase AC voltage wave, one cycle	A6-2

A6-2	Three-Phase AC voltage wave, one cycle	A6-3
A3-3	Power factor illustrated	A6-6
A6-4	Wye connection	A6-8
A6-5	Delta connection	A6-9
A6-6	Lines of magnetic flux around a bar magnet	A6-9
A6-7	Magnetizing current components	A6-14
A6-8	Terminal connections of a 230/460-volt, single-phase generator	A6-16
A6-9	Generation of electricity in a magnetic field	A6-17
A6-10	Simplified diagram of a single-phase generator	A6-19
A6-11	Conductor loop rotating in a magnetic field	A6-20
A6-12	Variation in voltage produced as conductor loop rotates in magnetic field	A6-21
A6-13	Simplified diagram of three-phase generator	A6-22
A6-14	Relation of voltage in each phase of three-phase power	A6-23
A6-15	Cutaway view of self-excited synchronous generator	A6-25
A6-16	Schematic diagram of electrical connections for a self-excited synchronous generator	A6-25
A6-17	Cutaway view of externally-excited synchronous generator	A6-27
A6-18	Schematic diagram of electrical connections for an externally-excited synchronous generator	A6-27
A6-19	Cutaway view of induction generator	A6-29
A6-20	Single-phase three-wire system	A6-33
A6-21	120/208-volt, three-phase, four-wire wye system	A6-33
A6-22	277/480-volt, three-phase, four-wire wye system	A6-33
A6-23	Three-phase, three-wire delta system	A6-35
A6-24	Three-phase, four-wire delta system	A6-35
A6-25	Terminal connections for 120/240 volts, single phase	A6-35

A6-26	Terminal connections for 120/208 volts, three phase	A6-36
A6-27	Terminal connections for 277/480 volts, three phase	A6-36
A6-28	Terminal connections for 240 volts, three phase	A6-37
A6-29	Terminal connections for 480 volts, three phase	A6-37
A6-30	Nameplate for a self-excited, self-regulated synchronous alternator	A6-39
A6-31	Nameplate for a brushless, synchronous alternator	A6-41
A6-32	Nameplate for an induction motor	A6-42
A7-1	Turbine setting coefficient definition	A7-5
A7-2	Critical sigma	A7-7

TABLES

A3-1	Values of planimetered areas from normal annual precipitation map of Hell Roaring Creek drainage	A3-5
A3-2	Data for flow duration values at various exceedance percentages, dimensionless values of flow duration for Pack River near Colburn, and the extrapolated values for Hell Roaring Creek at its mouth	A3-11
A3-3	Flow duration data for the Colburn gaging station on the Pack River	A3-12
A5-1	Capital cost estimate	A5-3
A5-2	Average rate for electricity in different areas of the U.S. ...	A5-4
A5-3	Operating costs	A5-6
A5-4	Interest factor for mortgage payment calculation	A5-8
A5-5	Present-value interest rate factor	A5-13
A7-1	Atmosphere pressure at various altitudes	A7-4
A7-2	Vapor pressure of water at various temperatures	A7-4

APPENDIX A

TECHNICAL SUPPORT

This group of appendices presents technical information in support of the main body of the handbook.

APPENDIX A-1

DEVELOPMENT OF THE POWER EQUATION

In Section 2.2, head was defined as the vertical change in water elevation. In hydropower, head is a convenient way to indicate the theoretical energy available from any given amount of water. Assume that the given amount is equal to 1 pound, slightly more than 1 pint. If the pound of water is at the top of the dam in Figure A1-1, the energy of that pound of water is 20 foot-pounds, and is referred to as potential energy or elevation head (assuming no friction loss).

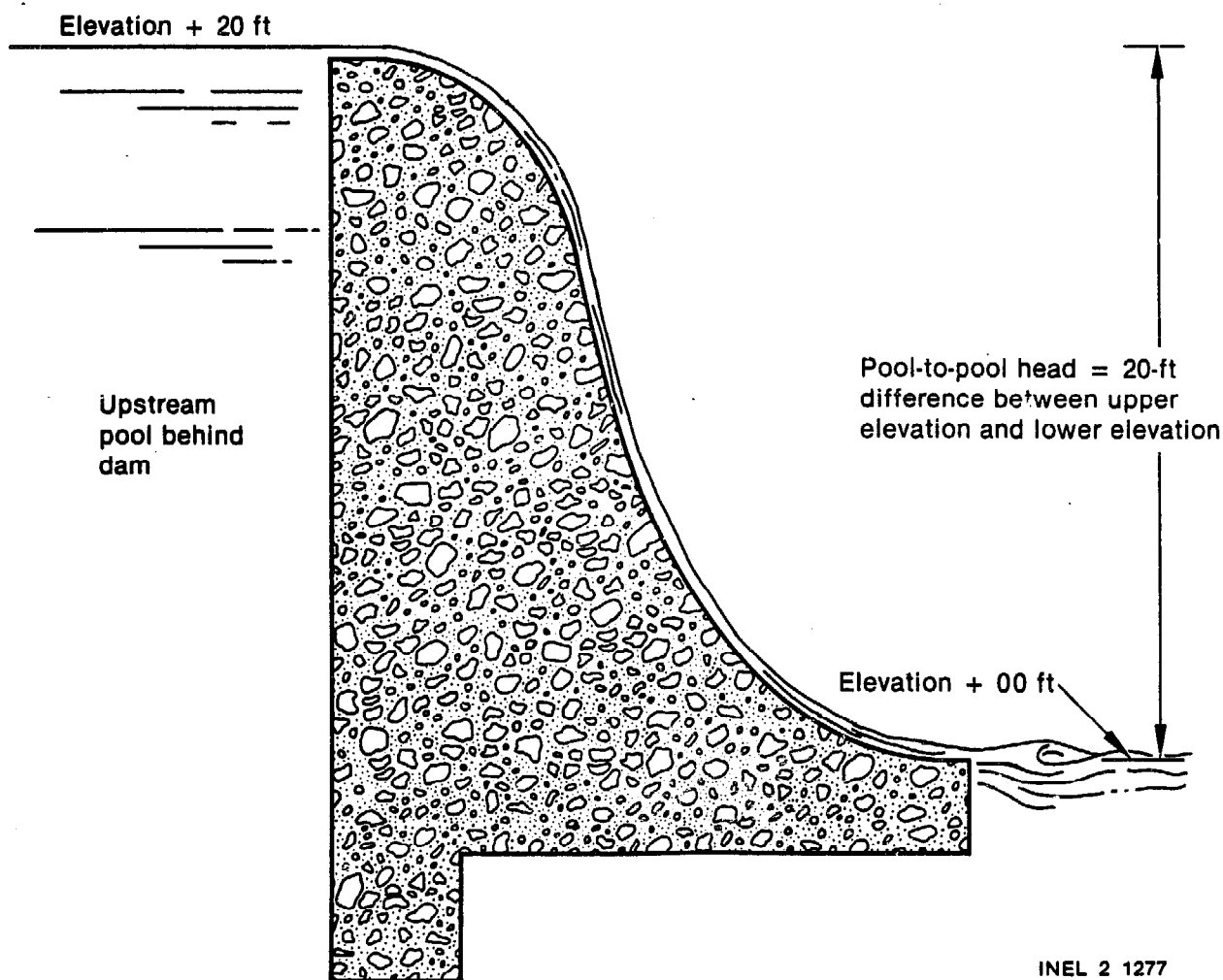

Figure A1-1. Pool-to-pool head.

INEL 2 1277

Thus, since

$$E = W \times h \quad (A1-1)$$

where

E = energy in foot-pounds

W = amount of water expressed as weight in pounds

h = head in feet,

energy = 1 pound x 20 feet = 20 foot-pounds.

If the pound of water flows over the dam and into the stream below, the energy available at the bottom of the dam is still 20 foot-pounds (assuming no friction loss). The pound of water flowing over the dam continues to increase in velocity until it reaches the stream below. This increase in velocity is called kinetic energy, or velocity head. Similarly, if a pipe penetrated through the dam 20 feet below the upper pool surface, a pound of water about to enter the pipe would have 20 foot-pounds of pressure head. The pressure is a result of the weight of 20 feet of water above the pipe (Figure A1-2).

It is important to remember that head is the theoretical energy available from any given amount of water that changes elevation [Equation (A1-1)]. Because of the effect of friction, the realized energy will always be less than the theoretical energy.

Energy is defined in Equation (A1-1) as an amount of water multiplied by the head. In the equation, the amount of water was expressed as a unit of weight. However, the amount of water is usually expressed as a volume--for example, gallons or cubic feet--not weight. The standard unit for volume in hydropower is the cubic foot.

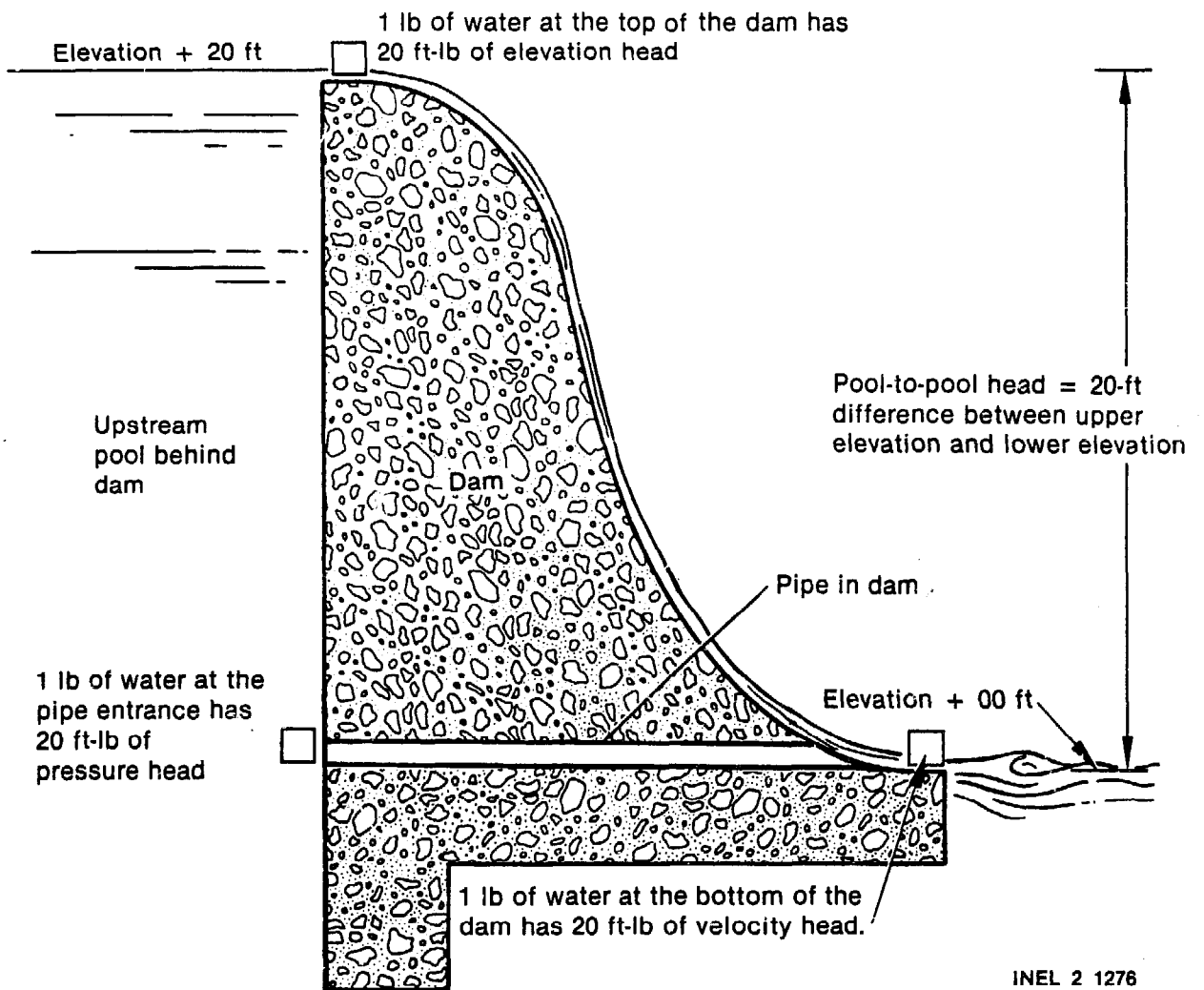

Figure A1-2. Elevation, pressure, and velocity head.

Weight is the volume of an object times its specific weight (weight density):

$$W = \gamma \times V \quad (A1-2)$$

where

W = weight in pounds

γ = specific weight density of the object in pounds per cubic foot (lb/ft^3)

V = volume of the object in ft³.

Solving Equation (A1-2) for specific weight:

$$\gamma = \frac{W}{V} .$$

Since 1 cubic foot of water contains 7.481 gallons (see Figure 2-2 in Section 2 of the handbook) and weighs 62.4 pounds, the specific weight of water (γ) can be expressed as 62.4 lb/ft³.

Equation (A1-2) for weight ($W = \gamma \times V$) can be substituted into Equation (A1-1) for energy ($E = W \times h$) to yield

$$E = \gamma \times V \times h \tag{A1-3}$$

where

E = energy in foot-pounds (ft-lb)

γ = specific weight of water, 62.4 lb/ft³

V = volume of water in ft³

h = head in feet.

If the volume of water over the dam in Figure A1-2 was 1 ft³ instead of 1 pound, the energy available would be 1,248 foot-pounds. From Equation (A1-3):

$$E = 62.4 \frac{\text{lb}}{\text{ft}^3} \times 1 \text{ ft}^3 \times 20 \text{ ft}$$

$$E = 62.4 \times 1 \times 20 = 1248 \text{ ft-lb}$$

Work is the transfer of energy from one physical system to another. In hydropower, work is the transfer of water energy to mechanical shaft energy in a turbine. Since work is the transfer of energy, the units for work are the same as energy (foot-pounds). Power is the time rate of doing work (transferring energy). From Equation (A1-3), we know that energy equals water specific weight times water volume times head ($E = \gamma \times V \times h$). To calculate theoretical power, energy must be divided by the time in which the work is performed:

$$P_{th} = \frac{\gamma \times V \times h}{t} \quad (A1-4)$$

where

P_{th} = theoretical power in foot-pounds per second (ft-lb/sec)

γ = specific weight of water, 62.4 lb/ft³

V = volume in ft³

h = head in feet

t = time in seconds.

Equation (2-1) in Section 2 of the handbook defines flow as the amount of water passing a point in a given time:

$$Q = \frac{V}{t} \quad (2-1)$$

Equation (A1-4) can be rewritten, using flow ($Q = V \div t$):

$$P = \gamma \times Q \times h \quad (A1-5)$$

where

P_{th} = theoretical power in ft-lb/sec

γ = specific weight of water, 62.4 lb/ft³

Q = flow in cubic feet per second (cfs)

h = head in feet.

Horsepower is the common expression for power. One horsepower is defined as 550 foot-pounds per second. Equation (A1-5) can be rewritten to calculate theoretical horsepower:

$$P_{th} = \frac{\gamma \times Q \times h}{550} \quad (A1-6)$$

where

P_{th} = theoretical power in horsepower (hp)

γ = specific weight of water, 62.4 lb/ft³

Q = flow in cfs

h = head in feet

550 = constant conversion to hp.

Since the specific weight of water, γ , is a constant, it can be combined with the horsepower constant, 550, to yield a new constant in the denominator of Equation (A1-5). Dividing 550 by 62.4 gives 8.81, and Equation (A1-5) can be written

$$P_{th} = \frac{Q \times h}{8.81} \quad (A1-7)$$

where

P_{th} = theoretical power in hp

Q = flow in cfs

h = head in feet

8.81 = constant for hp divided by specific weight.

The theoretical power does not consider the energy losses inherent in any system. The efficiency factor of any given system is the actual power produced divided by the theoretical power available, expressed as a percentage. Equation (2-3) in Section 2 of the handbook defined efficiency as

$$e = \frac{P}{P_{th}} \times 100 \quad (2-3)$$

where

e = efficiency expressed as a percentage (%)

P = actual power produced

P_{th} = theoretical power available

100 = conversion to %.

To calculate the actual horsepower produced for a given efficiency, Equation (A1-7) becomes

$$P = \frac{Q \times h \times e}{8.81} \quad (A1-8)$$

where

P = power in hp

Q = flow in cfs

h = head in feet

8.81 = constant for horsepower divided by specific weight

e = efficiency expressed as a decimal.

Reconsider the example in Figure A1-2 in which a certain amount of water is about to flow through the pipe in the dam. For this case, assume that the volume is 1 cubic foot and that the time required to flow out of the pipe is 1 second. Therefore, from Equation (2-1):

$$Q = \frac{V}{t} = 1 \text{ cfs}$$

Head in Figure A1-2 is 20 feet. Assume that the pipe is connected to a turbine and that the pipe, turbine, generator, and drive system losses result in a 60% efficient system. Then, from Equation (A1-8):

$$P = \frac{1 \text{ cfs} \times 20 \text{ ft} \times 0.60}{8.81}$$

$$P = 1.4 \text{ hp}$$

Electrical power is usually expressed in kilowatts (kW) instead of horsepower. Horsepower and kilowatt are both units of power:

$$1 \text{ kW} = 1.34 \text{ hp}$$

To convert Equation (A1-8) to one that yields power in kW, the constant in the denominator should be changed by multiplying 8.81 by 1.34. The power equation, with units in kW, then becomes

$$P = \frac{Q \times h \times e}{11.81} \quad (2-2)$$

where

P = power in kW

Q = flow in cfs

h = head in feet

e = efficiency

11.81 = constant of conversion and specific weight of water.

Equation (2-2) is the standard power equation that is discussed in Subsection 2.5 of the handbook.

APPENDIX A-2

ESTIMATING MINIMUM STREAM FLOW

This method is intended for Category 1 developers who have lived with their stream for years and can accurately estimate the low-water mark on the stream bed. The low-water mark is the average annual low-flow surface location on the stream bed. If the mark can be estimated, the float method for measuring flow can be used to estimate the low-flow value. The float method is described in Subsection 3.3.3.1.3. You are advised to take a few minutes to read that section before proceeding with this method.

Proceed with the following steps to estimate the area for low flow and determine the low-flow value.

1. As mentioned in Section 3.3.3.1.3, drive a stake on each side of the bank at the upper and lower crossings. The two crossings should be at least 30 feet apart. At each crossing, stretch a wire or a rope across the stream and level it with a carpenter's line level (see Figure 3-17 in Section 3 of the handbook).
2. At the upper crossing, estimate the location of the low-flow mark in the stream bed (Figure A2-1). Drive a stake in the stream at that location, and measure the vertical distance from the wire or rope to the stream bed. Cross the stream and measure from the wire or rope until the same depth is found on that side of the stream. Drive a second stake into the stream bed at that location (Figure A2-1). On a note pad, record the distance measured from the wire or rope to the low-flow mark on the stream bed at the upper crossing as m_1 . Now, repeat the process for the lower crossing, recording the distance measured as m_2 .
3. Determine the width of the estimated low-flow stream (Figure A2-1) by measuring the distance between the low-flow stakes at both crossings, and then divide the distance between each pair of stakes into equal segments.

(d_n) is the measured distance from wire or rope to stream bed at each segment

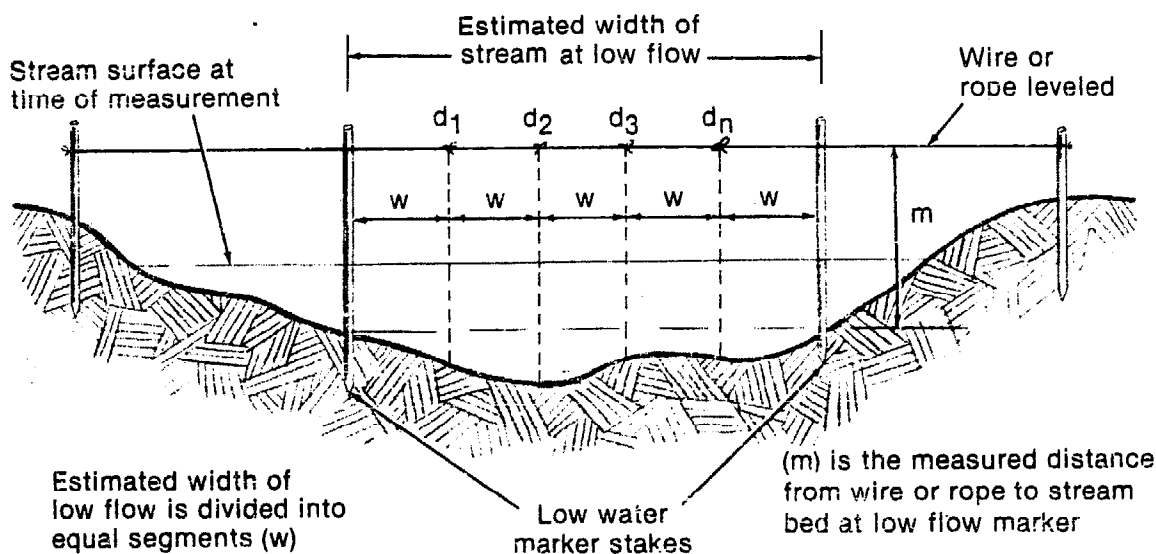

INEL 2 1363

Figure A2-1. Estimating minimum stream flow.

EXAMPLE: Assume that the width between one set of low-flow marker stakes is measured at $67 \frac{3}{8}$ inches. Divide this distance into equal segments.

NOTE: If you use a calculator, fractions must be entered as decimals. Convert a fraction to a decimal by dividing the bottom number into the top. In this case, since $3 \div 8 = 0.375$, round off to 0.38 and enter 67.38 into the calculator.

To divide 67.38 inches into equal segments, first divide the width by 12 to determine how many segments will be needed: $67.38 \div 12 = 5.62$ (rounded off). Use the whole number (in this case 5) as the number of segments, and divide that into the measured width: $67.38 \div 5 = 13.48$ inches (rounded off). Thus, the width of the equal segments for the example is 13.48 inches, and you would record that on your note pad as w_1 .

Follow the above procedure for the both crossings, and record the segment widths on your note pad, using w_1 for the upper crossing and w_2 for the lower crossing.

Now, measure off the equal segments on the wire or rope at each crossing, marking the division between each segment with a string.

NOTE: If you are using a standard tape measure, measure to the nearest 1/16 inch. In the example, for 0.48 inch, use 1/2.

4. At each segment marker, measure the depth of the water from the wire or rope to the stream bottom, and record the measurements on the note pad.

EXAMPLE:

<u>Upper Crossing</u> <u>(inches)</u>	<u>Lower Crossing</u> <u>(inches)</u>
$d_1 =$	$d_1 =$
$d_2 =$	$d_2 =$
$d_3 =$	$d_3 =$
.	.
:	:
.	.
$d_n =$	$d_n =$

where d is the depth in inches measured at each segment, and n is the number of segments.

5. Refer back to the portion of Section 3.3.3.1.3 that describes how to measure stream flow velocity with floats, and use that

procedure to make several (at least six) measurements of drift time from the upper crossing to the lower crossing. Record each drift time on the note pad.

6. After recording the drift times, make sure that you have all the field measurements, and then return to your home or office to use the calculator.

You should have the following measurements recorded on the note pad:

- o Depth from the wire or rope to the stream bed at the low-flow marker stake

m_1 (upper) =

m_2 (lower) =

- o Width of the individual low-flow segments

w_1 (upper) =

w_2 (lower) =

- o Measured depth at each segment marker from d_1 through d_n for both crossings

- o At least six drift times.

7. With the aid of a calculator, add up the measured depths for both the upper and lower crossings. From Equation (3-4) in Subsection 3.3.3.1.3 of the handbook:

$$D = d_1 + d_2 + d_3 + \dots + d_n$$

where

D = sum of the measured depths in inches

d = individual depths measured at each segment
in inches

n = number of measurements.

When you have performed the above calculation, you know the sum of the measured depths at each crossing. Record the sum for the upper crossing as D_1 and the sum for the lower crossing as D_2 .

8. Since the sum of the depths includes the distance measured from the wire or rope to the bottom of the stream for each measurement taken, the sum must be corrected so that it includes only the sum of the depths for the low-flow area. Use Equation (A2-1) to compute the corrected sum for each crossing.

$$D_c = D - (m \times n) \quad (\text{A2-1})$$

where

D_c = sum of the measured depths, corrected for low flow, in inches (one number for the upper crossing and one for the lower crossing)

D = uncorrected sum of the measured depths, as determined in the previous step; in inches (one number for the upper crossing and one for the lower crossing)

m = measured distance from the wire or rope to the stream bed at the low-flow stake (m_1 for the upper crossing and m_2 for lower crossing)

n = in each crossing, the number of segments.

9. Use Equation (3-5) from Subsection 3.3.3.1.3 of the handbook to calculate the area for each crossing.

$$A = \frac{w \times D_c}{144} \quad (3-5)$$

where

A = area of the low-flow portion of the stream at the particular crossing, in ft²

w = width of segments in inches (w₁ for the upper crossing and w₂ for the lower crossing)

D_c = sum of the depths, corrected for low flow, in inches (D₁ for the upper crossing and D₂ for the lower crossing)

144 = number of in² in a ft².

10. Now that you have determined the area of the low-flow portion of the stream at each crossing, use Equation (3-6) from the handbook to find the average area for the stream at low flow.

$$A = \frac{A_1 + A_2}{2} \quad (3-6)$$

where

A = average area of the two crossings in ft²

A₁ = area of the upper crossing in ft²

A₂ = area of the lower crossing in ft².

11. Now, use Equation (3-7) from the handbook to find the average drift time.

$$T = \frac{t_1 + t_2 + t_3 + \dots + t_n}{n} \quad (3-7)$$

where

T = average drift time in seconds

t = recorded time of each drift in seconds

n = number of drifts.

12. Since the surface of a stream flows faster than the bottom, a correction factor must be applied to the average time.
- o If the stream is flowing above the annual average flow level, use 0.6 as the correction factor for low flow.
 - o If the stream is flowing near or somewhat below annual average flow, use 0.7 as the correction factor for low flow.
 - o If the stream is measured during the low-flow season of the year, use 0.8 as the correction factor.

Use Equation (3-8) from the handbook to correct the average drift time.

$$T_c = \frac{T}{c} \quad (3-8)$$

where

T_c = corrected time in seconds

T = average time in seconds

c = correction factor.

13. Use Equation (3-9) from the handbook to compute the stream flow velocity.

$$v = \frac{L}{T_c} \quad (3-9)$$

where

v = velocity in feet per second (fps)

L = distance between crossings in feet

T_c = corrected time in seconds.

14. Now, use Equation (3-3) from the handbook to compute flow.

$$Q = A \times v \quad (3-3)$$

where

Q = flow in cubic feet per second (cfs)

A = average area in ft^2

v = velocity in fps.

An example of how to use this method is presented in the Run-of-the-Stream example of Appendix B-1.

APPENDIX A-3

RAINFALL RUNOFF CORRELATION^a

Often it is necessary to assess the desirability of developing microhydropower potential at sites where there are no flow measurements. Measurements that are representative of the long time average at such sites will be time consuming to record and more expensive than a microhydropower developer can afford. The following methodology gives an approach for making the necessary estimates with relatively little time and money. To illustrate the methodology, calculations were made for the small watershed of Hell Roaring Creek in Northern Idaho.

This method requires three basic items of information. A good map of the area, a map showing normal annual precipitation, and records of flow at a nearby stream gaging station that are representative of the pattern of runoff of the small watershed for which flow information is desired. Figure A3-1 gives a geographic representation of the situation. Here, the potential hydropower site is near the mouth of Hell Roaring Creek. The Hell Roaring Creek drainage basin is marked with crosshatching. The location of the stream gaging station (the Colburn station, No. 12392300, on the Pack River) is shown on the map. The gage is maintained by the U.S. Geological Survey. The boundary of the drainage basin upstream from the proposed site is delineated by a heavy black line with short dashes. Superimposed on the map are lines representing normal annual precipitation. These lines are called isohyetal lines, and they represent the amount of precipitation that falls in the shown area. The annual precipitation line is estimated to have the constant value indicated by the number shown at the break in the line. It is the inches of precipitation that would fall on that portion of the basin on the average. Maps of this type are available for most areas of the United States and can be obtained

a. Reference: Hawley, M. E. and McCuen, R. H., "Water Yield Estimation in Western United States," Journal of Irrigation and Drainage Division, Proceedings of American Society of Civil Engineers, Paper No. 16932, Vol. 108, No. IR1, March 1982.

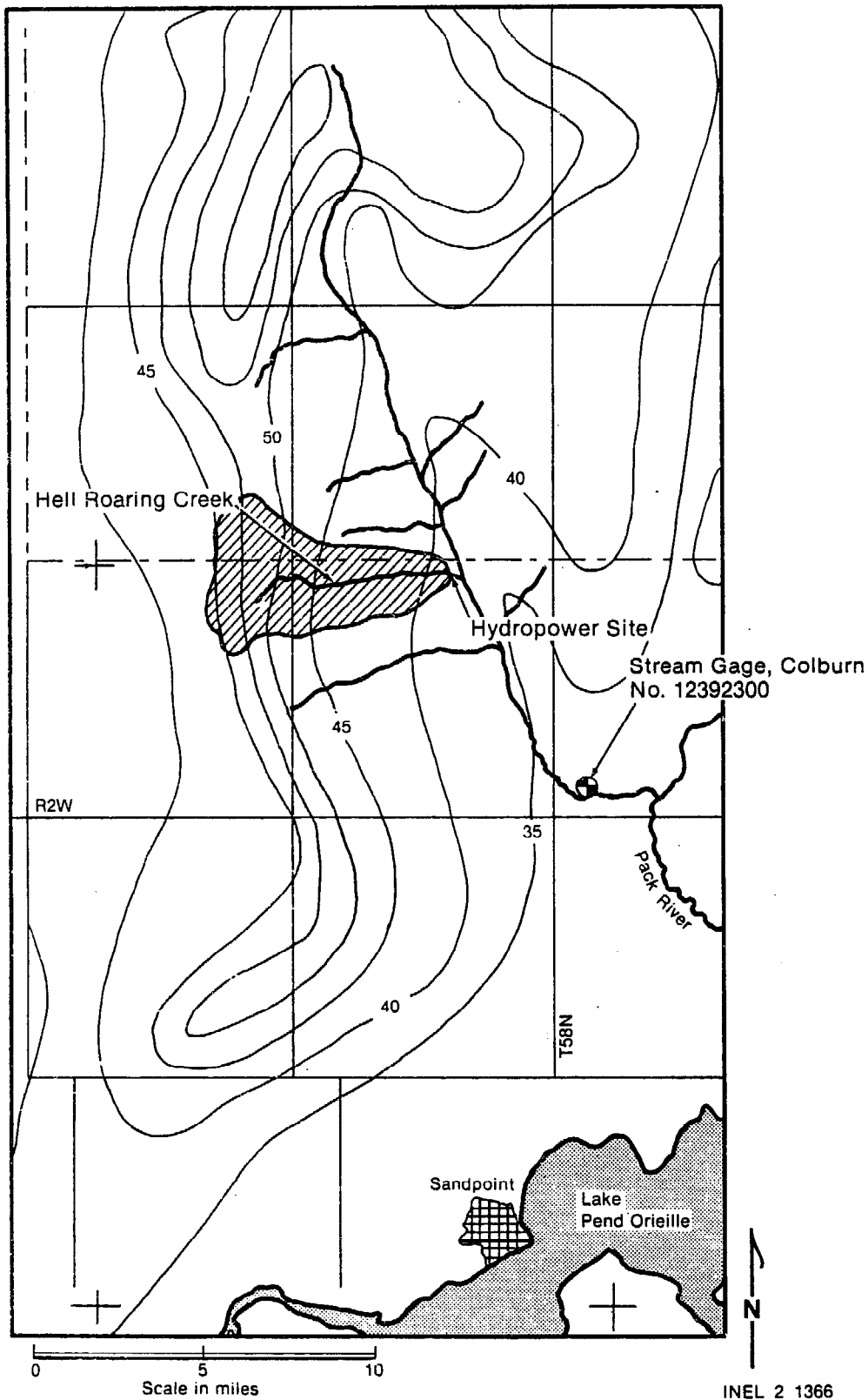
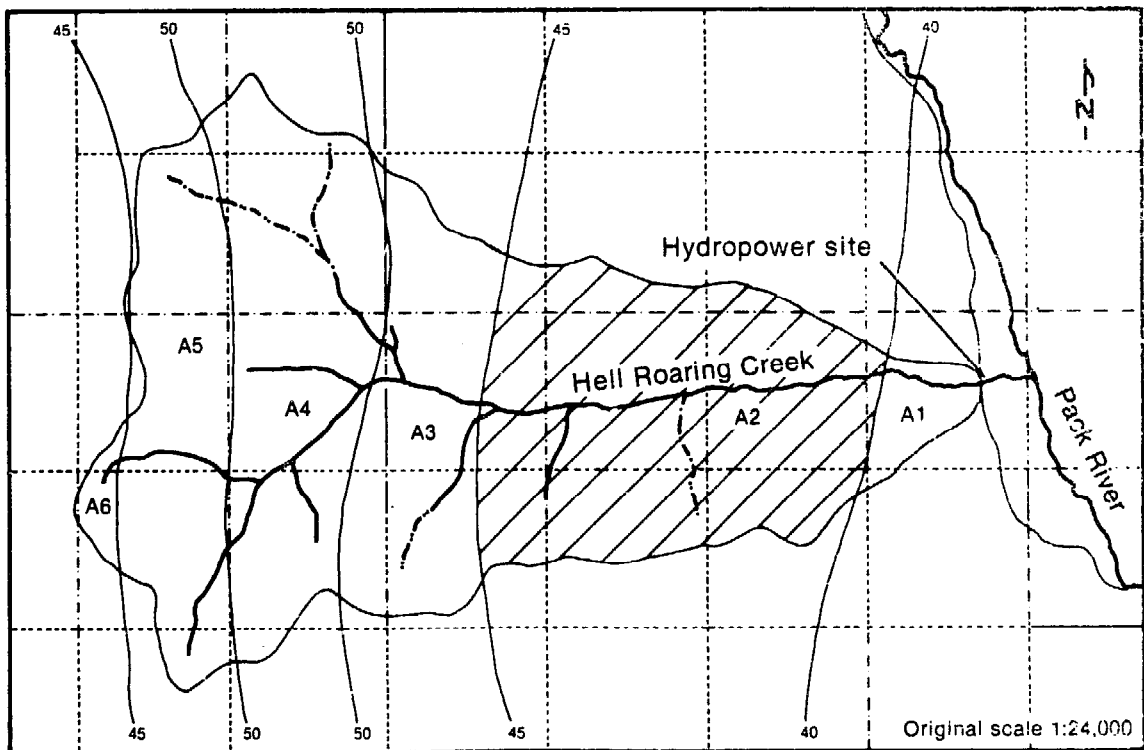

Figure A3-1. Hell Roaring Creek drainage basin and vicinity.

from the offices of the state water resources department, the U.S. Geological Survey, the U.S. Army Corps of Engineers, the U.S. Soil Conservation Service, and the water resource research centers located at state universities. In Idaho, a special set of such maps have been prepared for the purpose of furthering hydropower studies.

The job of outlining the basin and watershed boundaries is very important. This requires a map showing elevation contours that will permit outlining the watershed in which the precipitation contributes to the stream under consideration. The best available maps will normally be U.S. Geological Survey maps in as large a scale as is available. The preferred maps should be the 7.5-minute quadrangle sheets of the U.S. Geological Survey (USGS), where the scale is 1:24,000. Figure A3-2 is a facsimile of the 7.5-minute USGS map of Hell Roaring Creek on which the basin boundaries have been traced and the isohyetal lines superimposed.



INEL 2 1365

Figure A3-2. Map of Hell Roaring Creek drainage basin.

The first step is getting the necessary maps. The second step is choosing an appropriate stream gage for making estimates of runoff from precipitation. The choice of the stream gage is also very important. A discussion with local water resources people will help to ensure that the gage selected is representative of the watershed to be studied. A word of caution: a few drainages have unusual hydrologic conditions in which underground flow does not conform to the surface flow pattern, and in that case the method outlined here will give erroneous results. Also, where irrigation is involved, this method will not work. The staff of the U.S. Geological Survey or a state water resource department in the area are good sources to identify such problems.

The third step is to estimate the average annual precipitation that falls on the watershed contributing to the stream flow at the study site (see Figure A3-2). This is done by calculating the amount of precipitation that falls between two adjacent isohyetal lines. The area between the isohyetal lines is measured and then multiplied by the average of the two adjacent isohyetal lines bounding the measured area. The areas can be determined by placing a uniform grid over the area and counting squares or by using a mechanical device known as a planimeter, which measures areas enclosed by boundary lines on a map or piece of paper. That was done for the map in Figure A3-2, and Table A3-1 shows the results of the measurements. This was done on a 7.5-minute USGS map. As an example, the area between the 40-inch isohyetal line and the 45-inch isohyetal line on the 7.5-minute map contained 27.49 square inches. That area, A_2 , has been crosshatched to indicate the portion of the drainage basin involved in this particular step in calculating the weighted average of precipitation falling on the watershed.

The weighted average calculation for the whole watershed was made by using the following formula:

$$\bar{P} = \frac{(P_1 \times A_1) + (P_2 \times A_2) + (P_3 \times A_3) + \dots + (P_n \times A_n)}{A_1 + A_2 + A_3 + \dots + A_n} \quad (\text{A3-1})$$

where

- \bar{P} = average annual precipitation falling on the basin in inches
- P_1 = average precipitation value between first two isohyetal lines in inches
- A_1 = the planimetered area on the map between the first two isohyetal lines in square inches
- P_n = average precipitation value between last two isohyetal lines in inches
- A_n = the planimetered area on the map between the last two isohyetal lines in square inches.

TABLE A3-1. VALUES OF PLANIMETERED AREAS FROM NORMAL ANNUAL PRECIPITATION MAP OF HELL ROARING CREEK DRAINAGE

Area on Map	Isohyetal Line Values (in.)	Average Value of Precipitation Between Isohyetal Lines (in.)	Planimetered Area (in ²)
A1	40	40	2.43
A2	40 to 45	42.5	27.49
A3	45 to 50	47.5	13.47
A4	50	50	19.76
A5	50 to 55	47.5	14.15
A6	45	45	<u>1.04</u>
		TOTAL	78.34

The actual values used for the example on the map of Hell Roaring Creek are shown below:

$$\begin{aligned} \bar{p} &= \frac{40(2.43) + 42.5(27.49) + 47.5(13.47) + 50(19.76) + 47.5(14.15) + 45(1.04)}{2.43 + 27.49 + 13.47 + 19.76 + 14.15 + 1.04} \\ &= \frac{97.2 + 1168.3 + 639.8 + 672.1 + 46.8}{78.34} \\ &= \frac{3612.2}{78.34} \\ &= 46.1 \text{ inches} \end{aligned}$$

The watershed area on the map, A_M , as planimetered was found to be 78.34 square inches. This represents 313,360,000 square feet or 11.24 square miles on the surface of the earth. This was found by recognizing that a map scale of 1:24,000 means that 1 square inch on the map represents 24,000 x 24,000 square inches, or 4,000,000 square feet. The calculation below shows how the actual surface area was obtained.

$$A_T = \frac{A_M \times M_S^2}{C} \quad (A3-2)$$

where

- A_T = total drainage area in square miles
- A_M = planimetered area on the map, in square inches
- M_S = map scale
- C = conversion constant for appropriate units:
(12² in²/ft²) x (5280² ft²/mi²).

$$A_T = \frac{78.34 \times 24,000^2}{144 \times 27,878,000}$$

$$A_T = 11.24 \text{ square miles}$$

The next step is to convert the average annual precipitation into an average annual flow from the basin. This requires determining a runoff coefficient, K. The runoff coefficient is the ratio of the total average annual runoff from the basin to the total average annual precipitation falling on the basin when both are expressed in the same units. This coefficient has been compiled for most gaging stations. Contact should be made with the nearest U.S. Geological Survey office to obtain such a value. The U.S. Soil Conservation Service frequently will have made estimates of the runoff coefficients for particular areas. In Idaho, a hydrologic map project has developed average annual runoff coefficients for reaches of streams throughout the state. The coefficient for the Colburn gage of the Pack River in Idaho was found to be 0.76. If the runoff coefficient is not known, a weighted average precipitation calculation would have to be done for the drainage area above the stream gage. The same procedure would be used as previously explained. Since the actual runoff is known, K can be calculated; $K = \text{actual runoff measured at gaging station} \div (\text{weighted average precipitation falling on the basin} \times \text{the total area of the basin})$. It is important that the units of both measurements be the same. The units of the flow at the gage will normally be in cubic feet per second (cfs). One inch of precipitation over one square mile produces a flow of 0.07367 cfs over one year. The Pack River drainage basin above the Colburn gage covers 124 square miles, has an area weighted precipitation input of 46.31 inches and produces 321.53 cfs over one year.

Therefore

$$K = \frac{\bar{Q}_p}{P \times A_T \times C}$$

(A3-3)

where

- K = annual runoff coefficient
- \bar{Q}_p = actual runoff measured at gaging station (Colburn gage on the Pack River), in cfs
- \bar{P} = average precipitation falling on the basin, in inches
- AT = total drainage area, in square miles
- C = conversion constant for appropriate units:
0.07367 cfs/in-mi².

$$K = \frac{321.53}{46.31 \times 124 \times 0.07367}$$

$$K = 0.76$$

For the Hell Roaring Creek example, it was noted that the drainage area was steeper and the upper portions of the drainage supported less luxuriant vegetation than was characteristic of the entire drainage of the Pack River above the Colburn stream gage. As a consequence, the value of the annual runoff coefficient was increased by 0.02 to $K = 0.78$. This is an educated judgment step and should be done very carefully. It would be good to confer with a local hydrologic engineer or watershed hydrologist to confirm such action.

The calculation for the average annual flow of Hell Roaring Creek is then made as follows:

$$\bar{Q}_h = K \times C \times A \times \bar{P} \tag{A3-4}$$

where

\bar{Q}_h = average annual discharge for flow, cfs

K = runoff coefficient

C = conversion constant for appropriate units: 0.07367
cfs/in-mi²

A = drainage area, in square miles

\bar{P} = average precipitation falling on the basin in inches.

Therefore

$$\bar{Q}_h = 0.78 \times 0.07367 \times 11.24 \times 46.1$$

$$\bar{Q}_h = 29.8 \text{ cfs}$$

The next step is to plot a duration curve for the stream at the study site. A duration curve is a graphical plot of the flow versus the percent of time that a particular flow can be expected to be exceeded. The percent of time is called the exceedance (see Figure A3-3). A duration curve is necessary to calculate the potential power which can be generated at a site. As in the determination of the runoff coefficient, K, the measured flows at the Colburn gage on the Pack River were used to generate best estimate flow data for the Hell Roaring Creek site. The gaged flow values can be obtained from the district office of the U.S. Geological Survey. The flow values, Q, and the various exceedance percentages for the Colburn gage are listed in Table A3-2 and plotted in Figure A3-3. The data in Columns 1, 2, and 3 are based on flow records for the years 1969-1979.^a

a. The computational data for the flow duration values for the Pack River gaging station at Colburn are submitted as Table A3-3.

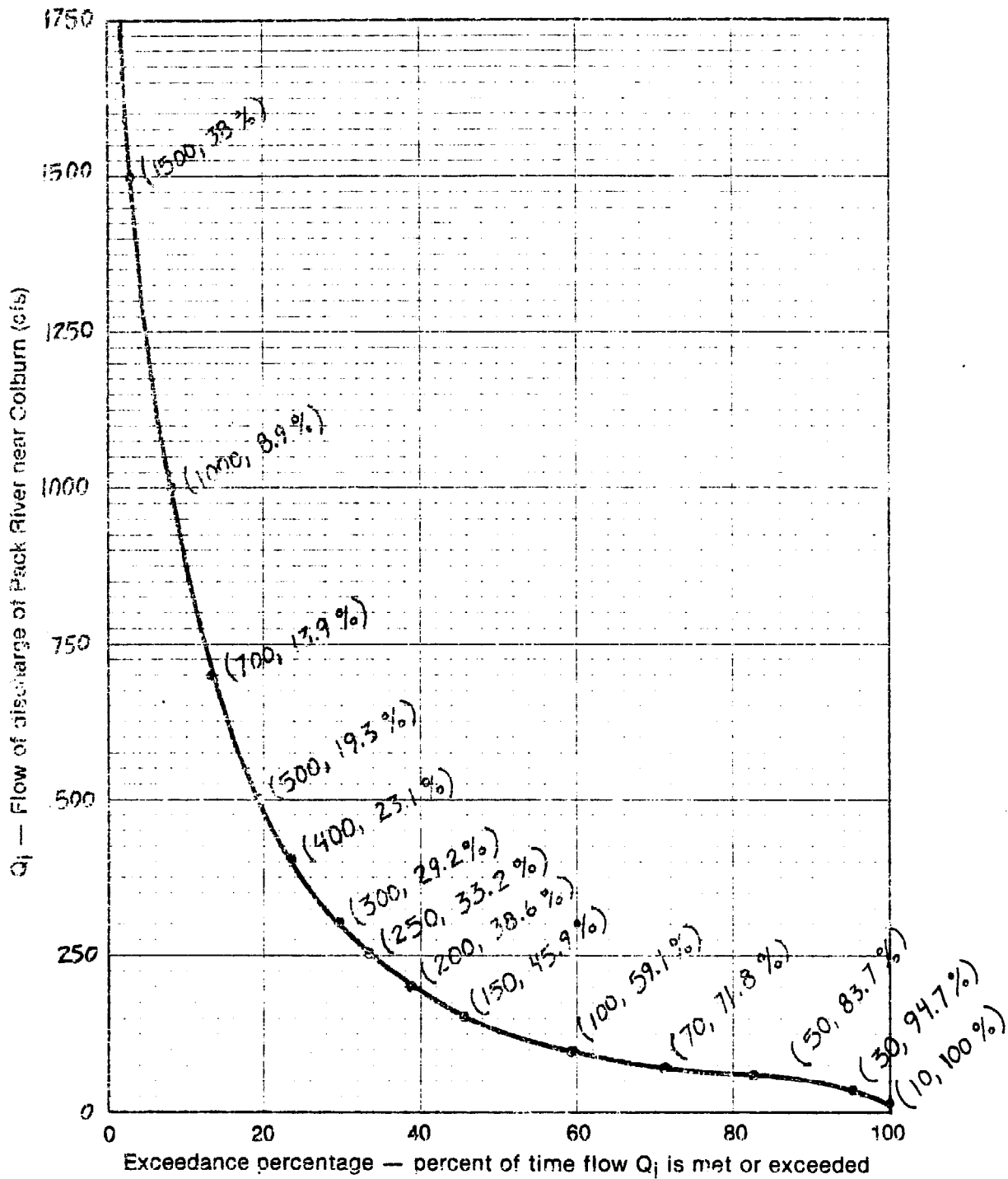

INEL 2 1369

Figure A3-3. Flow duration curve for Pack River near Colburn.

TABLE A3-2. DATA FOR FLOW DURATION VALUES AT VARIOUS EXCEEDANCE PERCENTAGES, DIMENSIONLESS VALUES OF FLOW DURATION FOR PACK RIVER NEAR COLBURN, AND THE EXTRAPOLATED VALUES FOR HELL ROARING CREEK AT ITS MOUTH

Upper Flow Interval Value for Pack River, Q_i (csf)	Number of Daily Flow Measurements In This Interval	Exceedance Percentage (%)	Dimensionless Flow Duration Value for Pack River, Q_i/\bar{Q}_p^a	Computed Upper Flow Interval Value for Hell Roaring Creek, Q_h^b (cfs)
		100		
10	354	94.7	0.031	0.03
30	764	83.7	0.093	2.78
50	826	71.8	0.156	4.63
70	883	59.1	0.218	6.48
100	915	45.9	0.311	9.27
150	510	38.6	0.467	13.90
200	371	33.2	0.622	18.54
250	282	29.2	0.778	23.17
300	421	23.1	0.933	27.80
400	262	19.3	1.244	37.07
500	378	13.9	1.555	46.34
700	346	8.9	2.177	64.88
1000	356	3.8	3.110	92.68
1500	169	1.3	4.665	139.36
2000	76	0.2	6.220	185.36
5000	16	0	15.55	463.41

a. $\bar{Q}_p = 321.53$ cfs

b. $Q_h = (Q_i/\bar{Q}_p)\bar{Q}_h$, where $\bar{Q}_h = 29.8$ cfs.

A3-11

Reproduced from
best available copy.



TABLE A3-3. FLOW DURATION DATA FOR THE COLBURN GAGING STATION ON THE PACK RIVER

FLOW DURATION TABLE																				
Class Water Year	PACK RIVER NEAR COLBURN, ID										STATION NO. 12.3923.00									
	1	2	3	4	5	6	7	8	9	10	11	12	13	14	15	16	17	18	19	
NUMBER OF DAYS IN CLASS																				
CLASS	CFS	TOTAL COUNTS	ACCUM	PERCENT	CFS/SQ MI	MEAN DAILY	CLASS	CFS	TOTAL COUNTS	ACCUM	PERCENT	CFS/SQ MI	MEAN DAILY	CLASS	CFS	TOTAL COUNTS	ACCUM	PERCENT	CFS/SQ MI	MEAN DAILY
1960	10	33	20	52	48	30	23	27	11	32	21	29	6	2	0	0	0	0	4.0	1.6
1961	25	31	27	38	24	19	12	26	13	32	11	25	11	9	2	0	0	19.3	4.0	2.2
1962	9	67	84	63	29	5	3	4	5	11	35	25	7	1	0	0	0	13.9	5.6	2.2
1963	11	44	13	18	46	35	31	36	26	20	25	16	0	0	0	0	0	8.9	8.1	3.1
1964	8	31	46	103	43	26	11	15	16	8	11	20	12	4	0	0	0	3.8	12.1	4.7
1965	0	12	37	37	115	42	4	4	4	10	14	37	13	0	0	0	0	1.3	16.1	6.2
1966	31	60	58	38	42	27	8	8	10	30	31	9	5	2	0	0	0	0.2	20.2	7.8
1967	67	31	10	17	45	43	25	33	10	6	13	13	20	6	2	0	0	0.1	24.2	9.3
1968	1	23	39	65	43	33	7	31	40	22	22	19	3	0	0	0	0	0.0	32.3	12.4
1969	2	43	13	35	70	21	33	29	12	14	18	23	13	7	0	1	0	0.0	40.3	15.6
1970	16	35	70	80	44	20	13	4	6	12	11	19	11	0	0	0	0			
1971	1	46	38	51	32	35	26	19	10	26	22	22	9	7	0	0	0			
1972	0	33	60	65	44	15	7	4	14	39	26	20	8	9	0	0	0			
1973	44	40	59	49	42	24	19	14	16	25	14	4	3	16	0	0	0			
1974	8	34	17	24	10	20	41	32	25	34	19	23	25	3	1	0	0			
1975	36	22	34	56	92	19	9	7	8	15	13	21	13	10	2	0	0			
1976	0	3	14	42	102	49	24	18	18	29	21	15	7	2	1	0	0			
1977	34	98	114	34	10	6	10	31	8	4	9	1	0	0	0	0	0			
1978	62	78	73	24	16	6	13	9	10	9	10	15	3	1	1	0	0			

TOTAL DISCHARGE			
CLASS	CFS	TOTAL COUNTS	ACCUM
1	10	365	6940
2	30	764	6575
3	50	826	5811
4	70	883	4985
5	100	915	4102
6	150	510	3187
7	200	371	2677
8	250	282	2306
9	300	421	2024
10	400	262	1603

TOTAL DISCHARGE			
MEAN DAILY DISCHARGE	DRAINAGE AREA	CFS/SQ MI	PERCENT
2231412.00 CFS-DAYS	124 SQ MI	0.1	100.0
321.53 CFS		0.2	94.7
		0.4	83.7
		0.6	71.8
		0.8	59.1
		1.2	45.9
		1.6	38.6
		2.0	33.2
		2.4	29.2
		3.2	23.1

The next step in estimating a flow duration curve for the ungaged site is to develop the duration curve for the gaged site. This is done by dividing all the Q values by \bar{Q}_p , the average flow for the gaged site. For the Colburn gage on the Pack River, $\bar{Q}_p = 321.53$ cfs, and Q can take on any value between 0 and 5000 cfs. To simplify the plotting, Q is given all the upper flow interval values, Q_i shown in Column 1 of Table A3-2. The resulting dimensionless Q_i/\bar{Q}_p values are shown in Column 4 of Table A3-2, and are plotted against the applicable exceedance percentage in Figure A3-4.

The final step in calculating a duration curve for the stream location in question, in this case the mouth of Hell Roaring Creek, is to proportion the curves according to the known and calculated average annual flows, \bar{Q}_p and \bar{Q}_h . This can be done because of the assumption that the runoff patterns for the two watersheds are analogous. The upper flow interval values for Hell Roaring Creek, Q_h , therefore, are proportionate to the upper flow interval values for the Pack River at the Colburn gage by the factor of \bar{Q}_h/\bar{Q}_p .

$$Q_h = Q_i \times (\bar{Q}_h/\bar{Q}_p) \quad (A3-5)$$

where

Q_h = upper flow interval values at the mouth of Hell Roaring Creek

Q_i = upper flow interval values at the Colburn Gage on the Pack River

\bar{Q}_h = average annual flow of Hell Roaring Creek

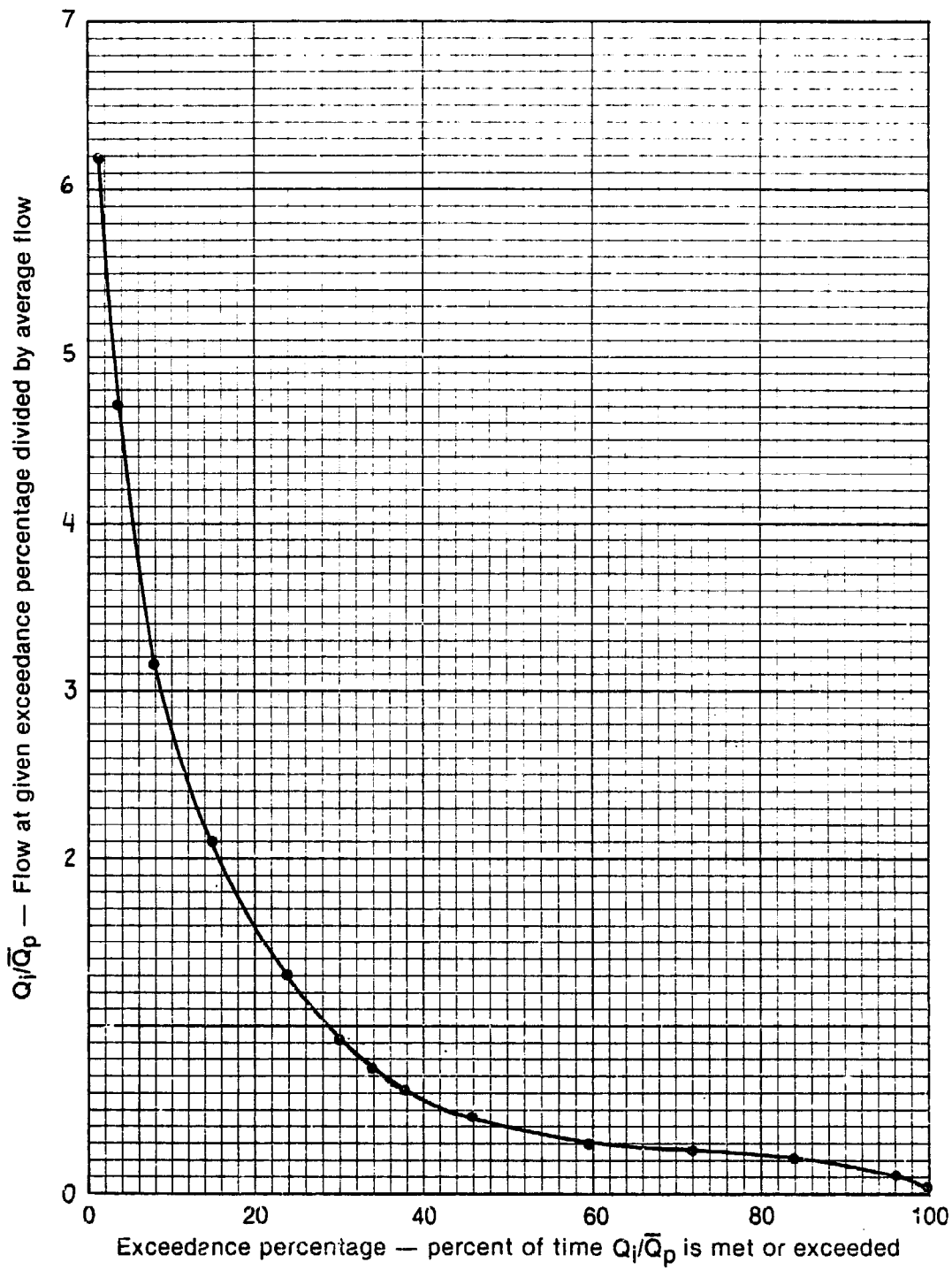

INEL 2 1367

Figure A3-4. Flow duration curve for Q_i/\bar{Q}_p .

\bar{Q}_p = average annual flow of the Pack River

$$Q_h = Q_i \times (29.8/321.53)$$

$$Q_h = Q_i \times 0.0927$$

The calculated Q_h values are shown in Column 5 of Table A3-2. Thus, Q_h at 45.9% exceedance = $Q_i \times (0.0927) = 100 \times (0.0927) = 9.27$ cfs. Figure A3-5 shows the estimated flow duration curve at the proposed microhydropower site at the mouth of Hell Roaring Creek.

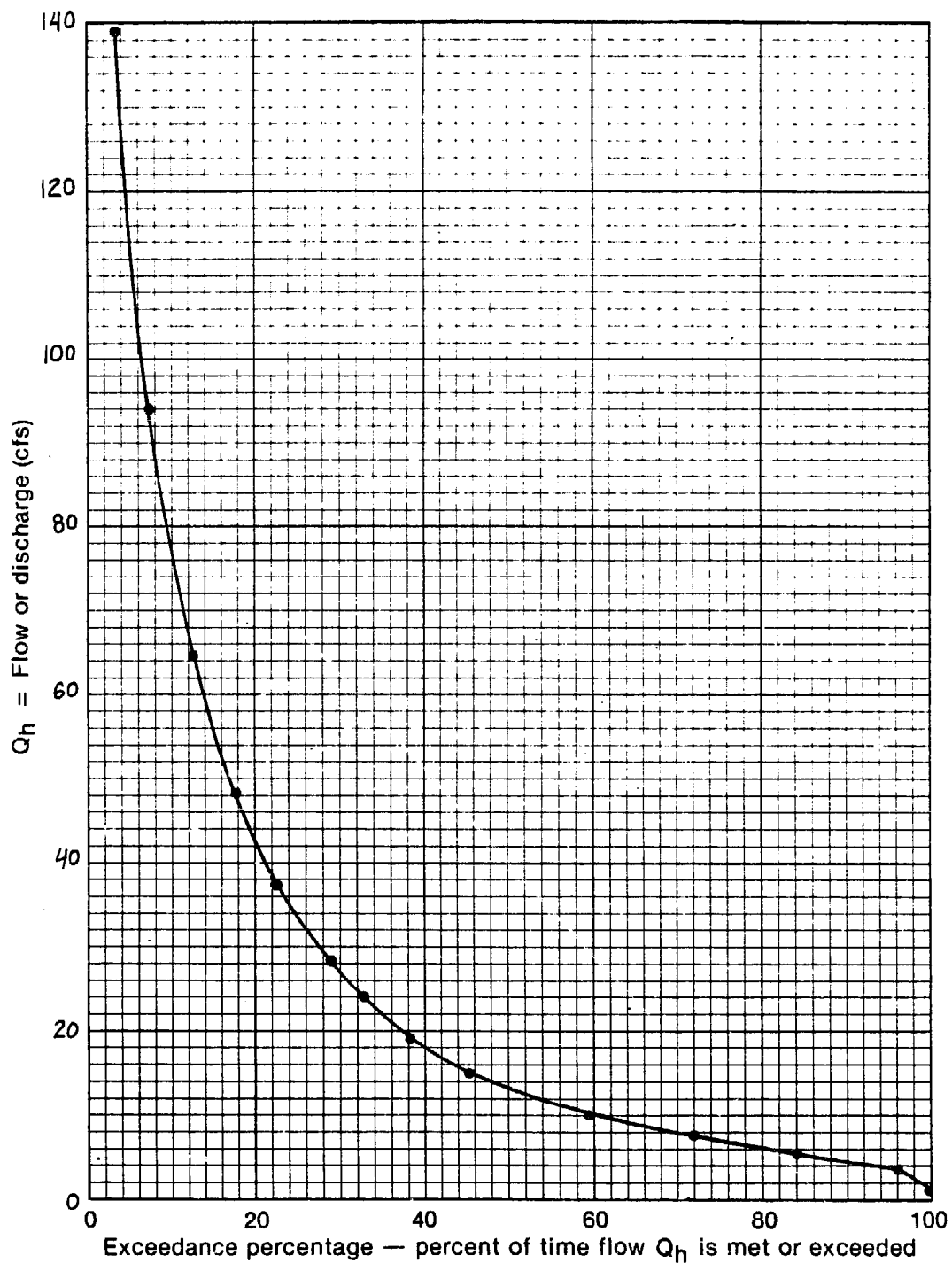

INEL 2 1368

Figure A3-5. Flow duration curve for the proposed microhydropower site at the mouth of Hell Roaring Creek.

APPENDIX A-4

STREAM FLOW PROJECTIONS WHERE A GAGE CORRELATION DOES NOT EXIST

In Section 3.3.3.2, a procedure was presented for correlating stream flows to stream gage records. When stream flow records do not exist in your area, you will have to correlate your stream flows to rainfall gage records. There are several sources for rainfall data; among them are:

- o Local radio and television stations (if they don't have records, they should be able to tell you where to find them)
- o Airport weather services
- o Local Weather Bureau offices
- o U.S. Department of Commerce
National Climatic Center
NOAA Environmental Data Service
Federal Building
Asheville, North Carolina 28801
- o Local U.S. Department of Agriculture Soil Conservation offices
- o U.S. Geological Survey offices.

A4-1. Category 1 Developers

Category 1 developers are interested in estimating the lowest streamflow value of the year. If you are unfamiliar with the stream, ask the area residents and local water users (irrigators, cities, etc.) when the lowest flows of the year occur. During the low-flow period, make several stream flow measurements using one of the methods described in Section 3.3.3.1. The lowest flow measured will be used to correlate to available rainfall records. Select the rain gage that is closest to your site. The rain gage must be operational during the year you are measuring

the stream flow. The correlation factor you use depends on the source of water for the stream. If your stream is fed mainly by snow melt, you will correlate to the average annual precipitation. If your stream is fed mainly by rainstorm runoff, you will correlate to the average monthly precipitation. Equations (A4-1) and (A4-2) give the correlation factors for the annual and monthly averages.

$$C = \frac{P_y}{P_{AA}} \quad (A4-1)$$

or

$$C = \frac{P_m}{P_{AM}} \quad (A4-2)$$

where

C = correlation factor

P_y = total precipitation for the year of your measurement

P_{AA} = average annual precipitation

P_m = total precipitation for the month of your measurement

P_{AM} = average monthly precipitation for the month of your measurement

The adjusted stream flow is given by Equation (A4-3).

$$Q = \frac{Q_m}{c} \quad (A4-3)$$

where

Q = adjusted flow

c = correlation factor [Equation (A4-1) or Equation (A4-2)]

Q_m = measured flow

This flow would then be used for estimating the power potential for your site.

A4-2. Category 2 Developers

Category 2 developers are interested in estimating the average flow for each month of the year. During each month of the year, make several stream flow measurements and find the monthly average of your measurements. Using Equation (A4-3), adjust your monthly averages. Be sure you use the current correlation factor in Equation (A4-3). Use Equation (A4-1) if your stream is fed mostly by snow melt, or Equation (A4-2) if your stream is fed mostly by rainstorm runoff. Record the correct monthly averages and proceed with Subsection 3.3.3.3.

APPENDIX A-5 ECONOMIC ANALYSIS

The economic viability of microhydropower depends primarily on capital costs plus a number of factors. To assist in the preparation of an economic analysis, a simplified cash flow will be presented. Once the step-by-step procedure for the cash flow analysis has been detailed, there are several other methods to assist in the overall economic analysis. These include a benefit-cost ratio, simple payback, and sensitivity analysis. Another dimension to the economic analysis is the evaluation of alternative sources of energy. Figure A5-1 is a block flow diagram of the economic analysis procedure.

Because this appendix was designed as a step-by-step procedure for evaluating economic alternatives, each item in the preparation of the cash flow analysis will be fully explained. The following sections discuss capital cost estimation, revenue estimation, operating cost estimation, depreciation, calculation of mortgage payments, taxes, preparation of the cash flow analysis, benefit-cost analysis, simple payback, and sensitivity analysis. Last, a comparison with alternative energy sources is presented.

A-5.1 Capital Cost Estimation

Estimates of capital cost were prepared in Section 4. For purposes of discussion, the project costs include the intake structure, penstock, powerhouse, generator, turbine, control equipment, bypass structure, tailrace, and distribution system. These project costs are also the direct costs. Indirect costs include contingencies, engineering costs, and financing costs. The sum of the indirect costs and the direct costs is called the capital cost. For purpose of an economic evaluation, a contingency figure of 15% of the direct cost should be included. The financing cost is the amount of interest required during construction, which will be capitalized on completion. "Capitalized on completion" means that the interest during construction is added to the capital cost and financed. Generally, a construction loan allows for a draw-down according to a work schedule, which means that a one-year construction phase would

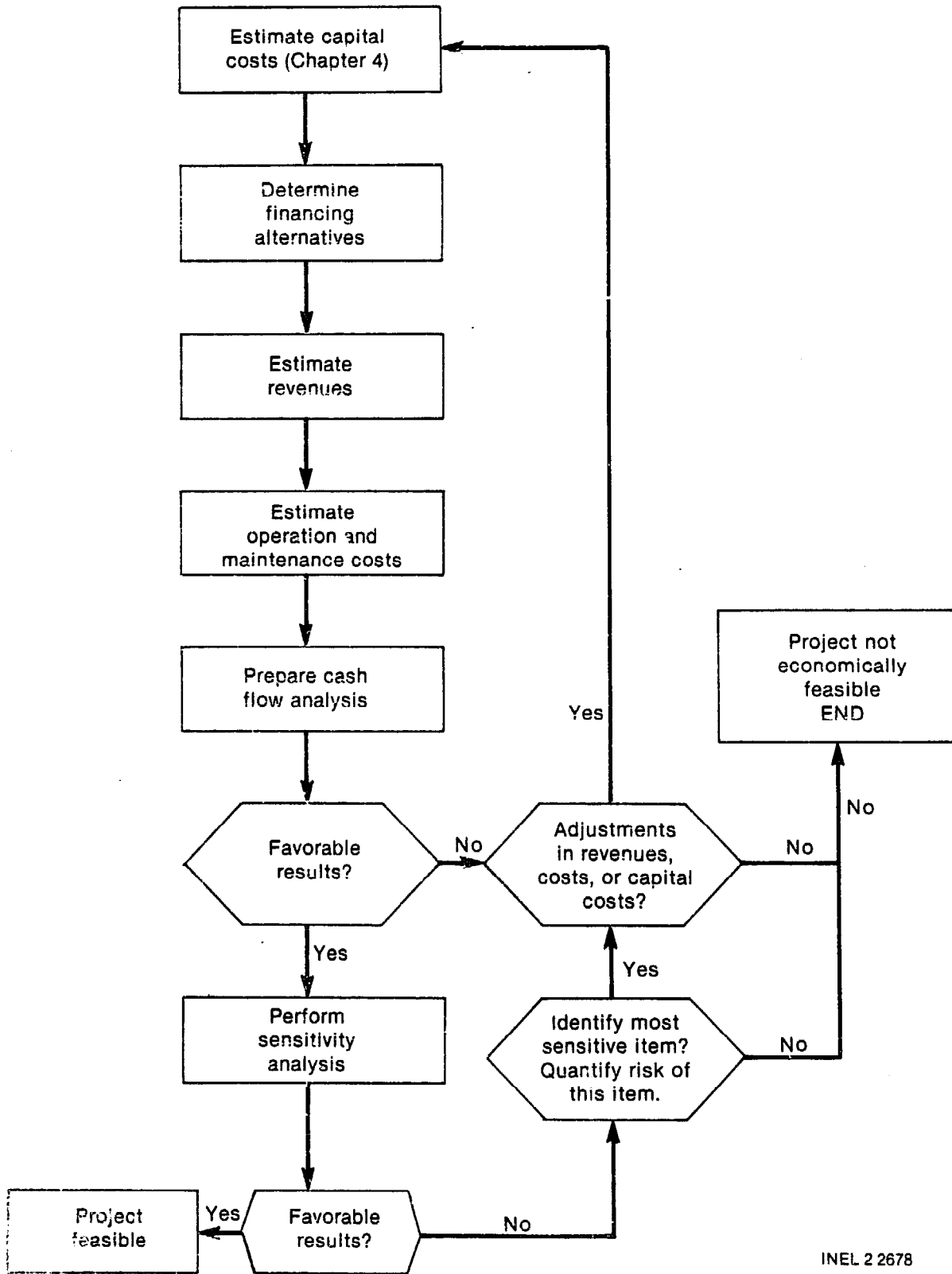

INEL 2 2678

Figure A5-1. Steps in the economic analysis procedure.

accrue annual interest at about half the interest rate. For estimation purposes, a construction loan of 18% drawn down linearly over one year results in an actual interest charge of approximately 9%. Table A5-1 can serve as a worksheet for a capital cost estimate.

TABLE A5-1. CAPITAL COST ESTIMATE

Intake structure	_____
Penstock	_____
Powerhouse	_____
Generator	_____
Turbine	_____
Electrical equipment	_____
Control Equipment	_____
Bypass structure	_____
Tailrace	_____
Switchyard	_____
TOTAL PROJECT COSTS	_____
Contingency @ 15% of project cost	_____
Engineering costs	_____
Financing costs @ 50% of interest rate	_____
TOTAL CAPITAL COSTS	_____

A-5.2 Revenue Estimation

Preparation of a simple cash flow analysis requires an estimation of revenues, which directly relate to the capacity of the system and the contracted price for energy. For ease of estimation, a calculation of 65% of the average electrical rate should represent an approximate revenue on a mills-per-kwh basis. NOTE: 1 mill = \$0.001. Table A5-2 gives the average rate for electricity in different areas of the U.S. The 65% factor is used because the utilities normally pay less than the average electrical rate for microhydropower.

Calculations in Section 3 detailed how to figure the average annual energy. That figure multiplied by the mills-per-kwh results in a net revenue. For example, a 100 kW-plant results in 438,000 kwh of production using a 50% plant factor.

$$100 \text{ kW} \times 8,760 \frac{\text{hours}}{\text{year}} \times 0.5 = 438,000 \text{ kWh/year}$$

TABLE A5-2. AVERAGE RATE FOR ELECTRICITY IN DIFFERENT AREA OF THE U.S.

<u>Region</u>	<u>Rate (mills/kwh)</u>
New England (CT, ME, MA, NH, RI, VT)	74.25
Middle Atlantic (NJ, NY, PA)	63.48
East North Central (IL, IN, MI, OH, WI)	47.62
West North Central (IA, KS, MN, MO, NE, ND, SD)	36.19
South Atlantic (DE, DC, FL, GA, MD, NC, SC, VA, WV)	40.58
East South Central (AL, KY, MS, TN)	46.09
West South Central (AR, LA, OK, TX)	44.62
Mountain (AZ, CO, ID, MT, NV, NM, UT, WY)	33.87
Pacific (CA, OR, WA)	52.15
Noncontiguous (AK, HI)	62.15

If your plant is located in the New England region, the cost of electricity (from Table A5-2) is 74.25 mills, and your approximate revenue per year can be figured as follows:

$$438,000 \times 0.65 \times 74.25 \times \$ 0.001 = \$21,138.96$$

Until contacts are made with a utility district, the revenue is only an approximate figure.

A-5.3 Operating Cost Estimation

Once the project is operational, there will be several annual costs which are called operating costs. These include operation and maintenance costs (O&M), general expense, insurance, and property taxes. O&M costs are those costs associated with running the facility. These costs may include cleanout of the tailrace, replacement of parts on the equipment, or general overhaul maintenance. For purposes of estimation, a figure of 1% of the project costs can be used for O&M costs. General expenses include any costs associated with administrative details of the project, e.g., legal expenses or accounting expenses. Insurance is the amount required to insure the facility. Property tax is the amount of increase in property taxes directly attributable to the improvement of the hydropower site. For estimation purposes, add the project costs to the current tax assessment and perform the following calculation:

$$t_1 = t_0 \times \frac{PC}{PE} \quad (A5-1)$$

where

t_1 = new property tax

PC = property assessment + project costs

PE = property assessment (found on an assessment statement from previous year)

t_0 = old property tax.

For convenience, Table A5-3 can be used to prepare operating costs.

TABLE A5-3. OPERATING COSTS

O&M (1% of capital costs)	_____
General expense	_____
Insurance	_____
Property Tax	_____
TOTAL OPERATING COSTS	_____

A-5.4 Depreciation

Depreciation is an operating expense and must be included as an operational cost. However, because it is a noncash expense, it should be itemized separately. There are four basic methods of depreciating the hydropower site. These are straight-line, sum-of-the years' digits, double-declining balance, and accelerated cost recovery. Straight-line depreciation is the simplest method and will be used to approximate the cash flow. If you are interested in understanding how to calculate depreciation using one of the other methods, you should obtain a book on accounting from your local library or contact the local Internal Revenue Service for information. For the straight-line method, subtract the salvage value from the depreciable costs and divide by the number of years the project is considered viable to obtain a uniform annual depreciation figure.

$$D = \frac{PC - SV}{y} \quad (A5-2)$$

where

- D = annual depreciation
- PC = project depreciable costs
- SV = salvage value at end of project life
- y = years project is viable.

NOTE: Subtract SV from PC before dividing by y.

A-5.5 Calculation of Mortgage Payments (Principal and Interest)

Calculation of a repayment schedule for the amount of debt financed is an important aspect of generating a cash flow statement. The capital requirements were established in Section 4 for cost estimating. Generally, a bank will require 20% equity in the form of cash or services and will finance 80% of the capital cost. First, determine the total capital requirements and multiply by 80%. Next, estimate the annual interest rate currently applicable. As a general rule, banks will finance at the prime rate plus 4%. Then determine the length of time the mortgage or loan will be in effect. Use Table A5-4 for the interest factor for the divisor. Finally, use the following expression to determine the yearly payment:

$$P = \frac{B}{I} \quad (A5-3)$$

where

- P = annual payment
- B = amount borrowed
- I = interest factor, from Table A5-4.

TABLE A5-4 INTEREST FACTOR FOR MORTGAGE PAYMENT CALCULATION

Number of Years	10%	12%	14%	15%	16%	18%	20%	24%	28%	32%
1	0.9091	0.8929	0.8772	0.8696	0.8621	0.8475	0.8333	0.8065	0.7813	0.7576
2	1.7355	1.6901	1.6467	1.6257	1.6052	1.5656	1.5278	1.4568	1.3916	1.3315
3	2.4869	2.4018	2.3216	2.2832	2.2459	2.1743	2.1065	1.9813	1.8684	1.7663
4	3.1699	3.0373	2.9137	2.8550	2.7982	2.6901	2.5887	2.4043	2.2410	2.0957
5	3.7908	3.6048	3.4331	3.3522	3.2743	3.1272	2.9906	2.7454	2.5320	2.3452
6	4.3553	4.1114	3.8887	3.7845	3.6847	3.4976	3.3255	3.0205	2.7594	2.5342
7	4.8684	4.5638	4.2883	4.1604	4.0386	3.8115	3.6046	3.2423	2.9370	2.6775
8	5.3349	4.9676	4.6389	4.4873	4.3436	4.0776	3.8372	3.4212	3.0758	2.7860
9	5.7590	5.3282	4.9464	4.7716	4.6065	4.3030	4.0310	3.5655	3.1842	2.8681
10	6.1446	5.6502	5.2161	5.0188	4.8332	4.4941	4.1925	3.6819	3.2689	2.9304
11	6.4951	5.9377	5.4527	5.2337	5.0286	4.6560	4.3271	3.7757	3.3351	2.9776
12	6.8137	6.1944	5.6603	5.4206	5.1971	4.7932	4.4392	3.8514	3.3868	3.0133
13	7.1034	6.4235	5.8424	5.5831	5.3423	4.9095	4.5327	3.9124	3.4272	3.0404
14	7.3667	6.6282	6.0021	5.7245	5.4675	5.0081	4.6106	3.9616	3.4587	3.0609
15	7.6061	6.8109	6.1422	5.8474	5.5755	5.0916	4.6755	4.0013	3.4834	3.0764
16	7.8237	6.9740	6.2651	5.9542	5.6685	5.1624	4.7296	4.0333	3.5026	3.0882
17	8.0216	7.1196	6.3729	6.0472	5.7487	5.2223	4.7746	4.0591	3.5177	3.0971
18	8.2014	7.2497	6.4674	6.1280	5.8178	5.2732	4.8122	4.0799	3.5294	3.1039
19	8.3649	7.3658	6.5504	6.1982	5.8775	5.3162	4.8435	4.0967	3.5386	3.1090
20	8.5136	7.4694	6.6231	6.2593	5.9288	5.3527	4.8696	4.1103	3.5458	3.1129

A5-8

Once the annual payment is calculated, a table can be formulated which delineates principal and interest over the life of the loan. To structure this table, use the following equation on a repetitive basis, with B changing as the balance decreases. The $(B \times i)$ is the amount of interest paid each year, while S equals the amount of principal:

$$S = P - (B \times i) \quad (A5-4)$$

where

- S = principal repaid
- P = annual payment
- B = balance owing in previous Year
- i = annual interest rate (in decimal form).

NOTE: Multiply B times i before subtracting from P.

For convenience, a 5-year example has been prepared where the amount borrowed is \$10,000 at 18% annual interest. From Table A5-4, the interest factor for 5 years at 18% is 3.1272. From Equation (A5-3), the annual payment is \$3,197.75.

$$P = \frac{10,000}{3.1272} = \$3,197.75$$

<u>Year</u>	<u>Payment</u>	<u>Interest</u>	<u>Principal</u>	<u>Balance</u>
0	\$ -0-	\$ -0-	\$ -0-	\$10,000.00
1	3,197.75	1,800.00	1,397.75	8,602.25
2	3,197.75	1,548.41	1,649.34	6,952.91
3	3,197.75	1,251.52	1,946.23	5,006.68
4	3,197.75	901.20	2,296.55	2,710.13
5	3,197.75	487.62	2,710.13	-0-

A-5.6 Taxes

Tax is the amount of state and federal tax that must be paid due to operating the hydropower plant. Tax considerations are very complex, and while the simplistic approach taken in the next few paragraphs is intended to aid in estimating taxes, it should not be considered an all-inclusive document on tax law. Professional tax counsel may be required. The project may be eligible for a regular investment tax credit of 10% and an energy tax credit of 11%. The investment tax credit is generally figured on "qualified" property, which is limited to specific equipment for production of revenue. Rulings by the IRS indicate that a hydroelectric plant structure housing a turbine and a generator qualify as "real property" and are eligible for the investment tax credit. Also qualifying for the tax credit are the costs of a reservoir, access roadways, dam structure, and preparation of site. (Rev. Rul. 72-223, 1972-1 C.B. 17. Rev. Rul. 72-96, 1972-1 C.B. 67.)

In addition, hydroelectric generating property is eligible for the 11% energy credit. This applies to all equipment used in generation (except transmission equipment), structures for turbines and generators, penstocks, and costs of strengthening the impoundment.

Tax credits reduce the tax liability on a dollar-for-dollar basis. The investment tax credit can be used up to a limit of \$25,000 in any one year. If taxes payable exceed this amount, the regular investment tax credit can be used to offset up to 90% (1982) of the tax liability in excess of \$25,000. The energy tax credit can be used to reduce the remaining tax liability to zero. In no case would the tax credit be refundable. If a developer's tax credits exceed the tax liability in any year, they can be carried back three years and carried forward fifteen years.

To estimate the tax liability, use the incremental percentage with which last year's taxes were figured. Estimate the state tax liability in the same manner. For example, if the previous year's federal taxes were figured at a base figure plus 33% of the amount in excess of the base

figure, the 33% becomes the incremental percentage to be used in calculating the tax effect. The same method should be used for state taxes and the two incremental percentages added together for total estimated taxes.

A-5.7 Preparation of the Cash Flow Analysis

The next step in preparation of the cash flow analysis is to use all the information previously gathered and prepare a table.

CASH FLOW ANALYSIS

Year	Revenues	Expenses	Depreciation	Capital Cost		Net Profit	Taxes	After Tax Cash Flow
				Principal	Interest			
1	(1)	(2)	(3)	(4)	(5)	(6)	(7)	(8)
2								
3								
4								
5								

The table can be itemized as follows: Item (1), revenues, is the amount of revenue estimated. Item (2), expenses, includes all the operating costs except depreciation. Item (3) is the depreciation figure. Item (4) is the amount of principal repaid yearly on the long-term debt. Item (5) is the amount of yearly interest paid on the long-term debt. Item (6) is the net profit, which is derived by starting with revenues (1) and subtracting expenses (2), depreciation (3), and interest (5). Item (7) is the tax estimation figure based on net profit (6). Item (8) is the net after tax cash flow which is derived by taking the net profit (6) and subtracting principal (4) and taxes (7) and adding back depreciation (3). The cash flow analysis is helpful to formulate a benefit-cost ratio or to see how many dollars the project actually nets the developer.

A-5.8 Benefit-Cost Analysis

Once the after-tax cash flow has been developed, the benefit-cost analysis is very straightforward. The first part of the analysis is to multiply each year's net after-tax cash flow by a present value interest factor. Table A5-5 provides the present-value interest factors. Selection of the interest rate factor can only be estimated during the early stages of the project. However, a good estimate would be the prime interest rate plus 4%. The sum of the present value of net after-tax cash flows equals the benefit. The cost is the capital cost.

For an example, a 5-year net after-tax cash flow will be presented with the present-value interest factors. After these are calculated, they are added together to yield the present value of the revenues.

<u>Year</u>	<u>After-tax Net Cash Flow</u>	<u>Present-Value Interest Factor at 16%</u>	<u>Present Value of Benefits</u>
1	200	0.8621	172
2	300	0.7432	223
3	350	0.6407	224
4	400	0.5523	221
5	450	0.4761	<u>214</u>
	TOTAL		1,054

The next step is to divide by the costs, which will yield a benefit-cost (B-C) ratio. If the installed project cost is \$1,000, the B-C ratio is 1.05. Any project with a B-C ratio greater than 1 should be considered as viable. When the B-C ratio is close to 1, the project has an internal rate of return equal to the present-value interest factor used.

TABLE A5-5 PRESENT-VALUE INTEREST RATE FACTOR

Period	5%	6%	7%	8%	9%	10%	12%	14%	15%	16%	18%	20%
1	0.9524	0.9434	0.9346	0.9259	0.9174	0.9091	0.8929	0.8772	0.8696	0.8621	0.8475	0.8333
2	0.9070	0.8900	0.8734	0.8573	0.8417	0.8264	0.7972	0.7695	0.7561	0.7432	0.7182	0.6944
3	0.8638	0.8396	0.8163	0.7938	0.7722	0.7513	0.7118	0.6750	0.6575	0.6407	0.6086	0.5787
4	0.8227	0.7921	0.7629	0.7350	0.7084	0.6830	0.6355	0.5921	0.5718	0.5523	0.5158	0.4823
5	0.7835	0.7473	0.7130	0.6806	0.6499	0.6209	0.5674	0.5194	0.4972	0.4761	0.4371	0.4019
6	0.7462	0.7050	0.6663	0.6302	0.5963	0.5645	0.5066	0.4556	0.4323	0.4104	0.3704	0.3349
7	0.7107	0.6651	0.6227	0.5835	0.5470	0.5132	0.4523	0.3996	0.3759	0.3538	0.3139	0.2791
8	0.6768	0.6274	0.5820	0.5403	0.5019	0.4665	0.4039	0.3506	0.3269	0.3050	0.2660	0.2326
9	0.6446	0.5919	0.5439	0.5002	0.4604	0.4241	0.3606	0.3075	0.2843	0.2630	0.2255	0.1938
10	0.6139	0.5584	0.5083	0.4632	0.4224	0.3855	0.3220	0.2697	0.2472	0.2267	0.1911	0.1615
11	0.5847	0.5268	0.4751	0.4289	0.3875	0.3505	0.2875	0.2366	0.2149	0.1954	0.1619	0.1346
12	0.5568	0.4970	0.4440	0.3971	0.3555	0.3186	0.2567	0.2076	0.1869	0.1685	0.1372	0.1122
13	0.5303	0.4688	0.4150	0.3677	0.3262	0.2897	0.2292	0.1821	0.1625	0.1452	0.1163	0.0935
14	0.5051	0.4423	0.3878	0.3405	0.2992	0.2633	0.2046	0.1597	0.1413	0.1252	0.0985	0.0779
15	0.4810	0.4173	0.3624	0.3152	0.2745	0.2394	0.1827	0.1401	0.1229	0.1079	0.0835	0.0649
16	0.4581	0.3936	0.3387	0.2919	0.2519	0.2176	0.1631	0.1229	0.1069	0.0930	0.0708	0.0541
17	0.4363	0.3714	0.3166	0.2703	0.2311	0.1978	0.1456	0.1078	0.0929	0.0802	0.0600	0.0451
18	0.4155	0.3503	0.2959	0.2502	0.2120	0.1799	0.1300	0.0946	0.0808	0.0691	0.0508	0.0376
19	0.3957	0.3305	0.2765	0.2317	0.1945	0.1635	0.1161	0.0829	0.0703	0.0596	0.0431	0.0313
20	0.3769	0.3118	0.2584	0.2145	0.1784	0.1486	0.1037	0.0728	0.0611	0.0514	0.0365	0.0261

A-5.9 Simple and Discounted Payback

The simple payback is the number of years required to return the capital cost with the net after-tax cash flow. In the previous example, the simple payback is 3.4 years. If the net after-tax cash flows were uniform, one would divide that number into the capital cost for a simple payback. For example, if the project generated \$300 per year in net after-tax cash flows, the payback would be 3.3 years.

The discounted payback operates on the same principle as the simple payback but uses the present value of the benefits as the net after-tax cash flow. In the example cited above, the discounted payback is 4.7 years.

A-5.10 Sensitivity Analysis

A sensitivity analysis is the process of varying one or more of the parameters to determine what effect a change of a particular variable will have on the whole economic analysis. The sensitivity analysis considers the following questions:

- o What if revenues increase or decrease by 10%?
- o What if capital costs escalate above the 15% contingency?
- o What if interest rates decrease or increase by 2 percentage points?
- o What if operating costs are evaluated at 3% of capital cost instead of 1%?

The procedure for performing the sensitivity analysis is to think about what is most likely to affect the project's economics and vary that parameter first. Then recalculate all of the annual cash flows and reevaluate the B-C ratio. Generally, the capital cost will be the most sensitive item because it drives the benefit-cost ratio. From the previous example, a 10% increase in capital costs (\$1100) results in a 0.96 B-C

ratio ($1054 \div 1100 = 0.96$). Because hydropower is capital intensive and because net revenues are discounted, a decision based only on the B-C ratio may be wrong.

A-5.11 Alternative Energy Sources

Repeating the cash flow analysis with the cost of an alternative, more expensive source of energy generally results in hydropower having a more favorable analysis. For example, a farmer has a need for 30 kW of peak power and an annual energy production of 111,000 kWh. In analyzing his options other than microhydropower, he has found that he can generate the required electricity with an oil-powered generator or buy the electricity from a utility. Currently (1982), using an oil-powered generator costs \$5.29 per million Btu, which equates to a cost of \$0.018 per kWh. A million Btu's equals 293 kWh. If oil escalates at 10% per year for 15 years, the oil generation fuel bill would be \$22.10 per million Btu or \$0.075 per kWh. Electricity supplied by a utility company currently costs \$0.03 per kWh. This cost escalated at 10% per year for 15 years would be \$0.125 per kWh. The cost of installing the 30 kW microhydropower unit amortized over the 15-year period is \$3000 (using an approximate capital cost of \$1500 per megawatt). Operating costs at 1% of capital costs are \$450 in the first year of the project. Escalating operating costs at 10% for 15 years results in a cost of \$1880, or \$0.017 per kilowatt-hour. Inclusion of the capital costs results in a cost of \$0.04 per kilowatt-hour. Clearly, the most reasonable choice is the microhydropower unit.

APPENDIX A-6

ELECTRICAL THEORY

Section 4.8 of the handbook contains a brief description of how to size the generator, the wiring, and the overcurrent device. This appendix is a more detailed overview of:

1. Basic electrical terms as they apply to generator theory
2. The basic generator concept, as well as synchronous and induction generator theory of operation
3. Standard voltage connections and how they are obtained from a standard 12-wire generator
4. Generator nameplates
5. The parameters of insulation and enclosures as they apply to standard generators
6. Development of simple electrical equations to show how they apply to microhydropower development projects.

A-6.1 Electrical Terminology

Volt (E)--The common measure of electrical pressure.

Effective Voltage--Also called RMS voltage (root-mean-square voltage), effective voltage is 0.707 of the maximum value of the voltage wave as shown in Figure A6-1. Effective voltage is the voltage measured by the usual ac voltmeter. The symbol for voltage is E. The abbreviation for voltage is "V", as in 120 V = 120 volts.

Ampere (I)--The unit rate of flow of electric current. It is the value indicated by a common ac ammeter. The symbol for current is I. The abbreviation for current is "A", as in 30 A = 30 amps.

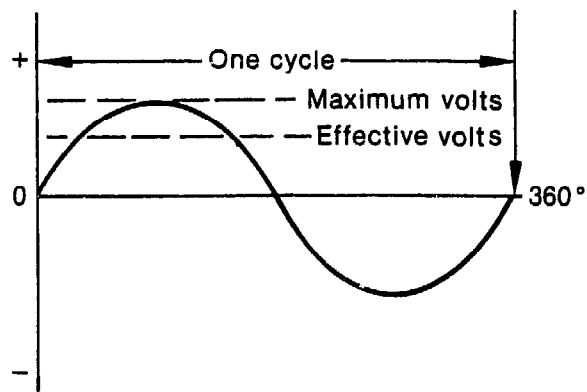

INEL 2 3202

Figure A6-1. Single-phase ac voltage wave, one cycle.

Resistance (R)--The measure of hindrance or impedance to current flow. Resistance is measured in ohms. The symbol for resistance is R, and the abbreviation is omega-- Ω .

Ohms Law--The fundamental Ohm's Law shows the relationship between current, resistance, and voltage.

$$E = I \times R \quad (A6-1)$$

where

- E = voltage in volts
- I = current in amperes
- R = resistance in ohms.

Cycle--One cycle is the rotation of a single phase wave of electricity from zero to positive maximum, back through zero to negative maximum, and back to zero--or 360 degrees, as shown in Figure A6-1. The cycle for perfect alternating current is a sine wave with no ripples or distortions.

Frequency (f)--The number of cycles per second, given the name Hertz (Hz).

AC Voltage--AC voltage alternates in a regular cycle. Figure A6-1 shows a single phase wave of ac voltage.

AC Current--AC current also alternates in a regular cycle. A single phase wave of ac current is similar to that shown for ac voltage in Figure A6-1.

Phase--If the electrical power is provided in what amounts to three circuits which reach corresponding values at 120-degree intervals, the system is three phase (Figure A6-2). Three-phase power is used because it provides smoother operation for running large electrical loads, and is an economical method of transmitting power, since it can transmit more power than a single-phase system.

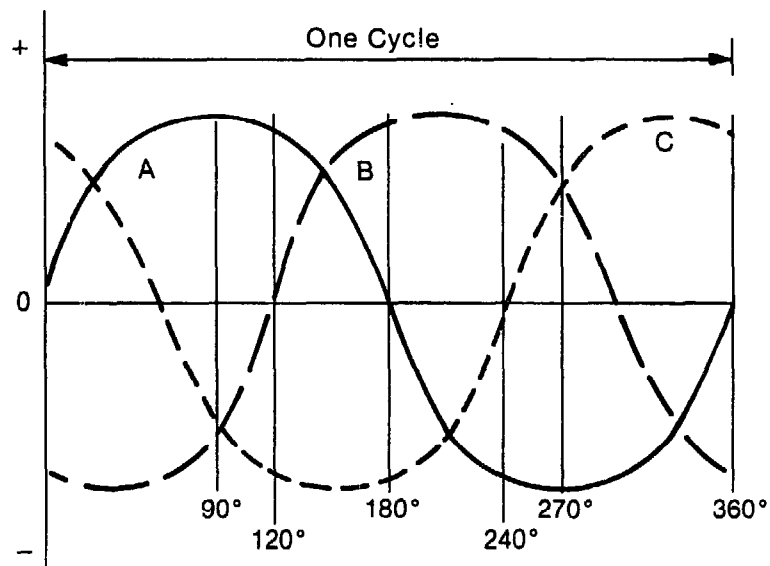

INEI 2 3201

Figure A6-2. Three-phase ac voltage wave, one cycle.

Inductance (L)--A device with iron in the magnetic circuit has what amounts to magnetic inertia. This inertia is resistant to any change in current. Since the voltage value, and therefore the current value, is always changing in alternating current, the inertia characteristic of opposing any change in current causes the current change to lag behind the voltage change. It also serves to limit the current value. This effect, known as inductance, is measured in henries.

Inductive Reactance (X)--The effect of inductance varies with the frequency, and the term inductive reactance is used to express this effect.

$$X = 2 \times \pi \times f \times L \quad (A6-2)$$

where

X = inductive reactance in ohms

f = frequency in Hertz (cycles per second)

L = inductance in henries

π = pi = 3.1416.

Impedance (Z)--In ac circuits, the flow of current is limited by both resistance and inductive reactance. The combination of these two elements is known as impedance. Mathematically, when resistance and inductive reactance are present,

$$Z = \sqrt{R^2 + X^2} \quad (A6-3)$$

where

Z = impedance in ohms

R = resistance in ohms

X = inductive reactance in ohms.

By Ohm's Law then,

$$E = I \times Z \quad (A6-4)$$

where

E = effective voltage

I = effective value of ac amperes

Z = impedance.

Power (P)--Electrical power (P) is measured in watts (W), kilowatts (1000 W = 1 kW), or megawatts (1,000,000 W = 1 MW or 1000 kW = 1 MW).

A watt is the product of one ampere of effective current flowing at a pressure of one effective volt. In alternating current, a further condition is that the voltage and current must be in phase, that is, they must both reach zero, maximum positive, and maximum negative values at the same instant.

Assuming that the voltage and current are in phase,

In single-phase service:

$$P = EI; \text{ kW} = EI/1000 \quad (\text{A6-5})$$

In two-phase service:

$$P = \sqrt{2}EI; \text{ kW} = \sqrt{2}EI/1000 \quad (\text{A6-6})$$

In three-phase service:

$$P = \sqrt{3}EI; \text{ kW} = \sqrt{3}EI/1000 \quad (\text{A6-7})$$

If the current and voltage are not in phase, that is, they do not reach corresponding values at the same instant, the resultant product of current and voltage is apparent power instead of actual power. Apparent power is measured in volt-amperes (VA) or kilovolt-amperes (1000 VA = 1 kVA).

Apparent power is measured as follows:

In single-phase service:

$$\text{VA} = EI; \text{ kVA} = EI/1000 \quad (\text{A6-8})$$

In two-phase service:

$$VA = \sqrt{2}EI; \text{ kVA} = \sqrt{2}EI/1000 \quad (\text{A6-9})$$

In three-phase service:

$$VA = \sqrt{3}EI; \text{ kVA} = \sqrt{3}EI/1000 \quad (\text{A6-10})$$

Power Factor--The factor by which apparent power (volt-amperes) is multiplied to obtain actual working power (watts).

In most magnetic circuits, the current will lag behind the voltage. A typical case is represented in Figure A6-3, where the current changes lag 36.9 degree behind corresponding voltage changes. At any instant when the current wave and voltage wave are both positive or both negative, the resulting power is positive [$EI = W$, or $(-E)(-I) = W$]. This is represented by the crosshatched area above the zero line in the figure.

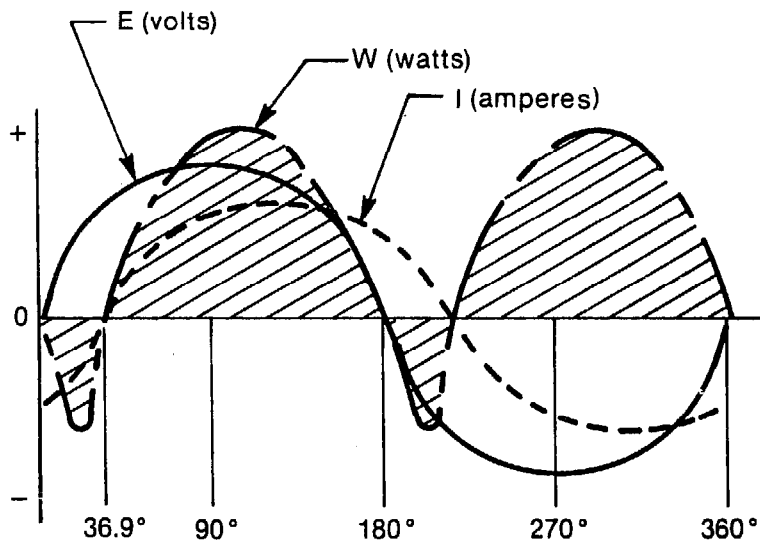

INEL 2 2300

Figure A6-3. Power factor illustrated.

When either the current wave or voltage wave is negative and the other is positive, the resulting power is negative [$(-E)I = -W$, or $E(-I) = -W$]. This is represented by the crosshatched area below the zero line in the figure. The net power is the positive area minus the negative area. The power factor is the net power divided by the apparent power.

Mathematically, the power factor is equal to the cosine of the angle by which the current lags (or in rare cases leads) the voltage. In Figure A6-3, the angle of lag is 36.9 degrees. The cosine of the angle 36.9 degrees, and thus the corresponding power factor for that amount of lag is 0.80 (80.0%) lagging power factor.

Ground--A conducting connection, whether intentional or accidental, between an electrical circuit or equipment and the earth or to some conducting body that serves in place of the earth. The ground is a zero reference plane for voltages.

Neutral--The conductor of a power system that is intentionally connected to the ground at the source of power or service.

Load--The consumption of power by the equipment that is connected to an electrical system.

Wye Connection--The method of connecting of a three-phase generator so that each of the three phases carries current differing in phase by 120 degrees from the other two. This connection is such that the coils all have a common reference point. This connection is also called a star connection. See Figure A6-4.

Power in a wye-connected system is given by:

$$P = \sqrt{3}EI \quad (A6-11)$$

where

P = power in watts

E = voltage between phases, in volts

I = current in each phase, in amperes.

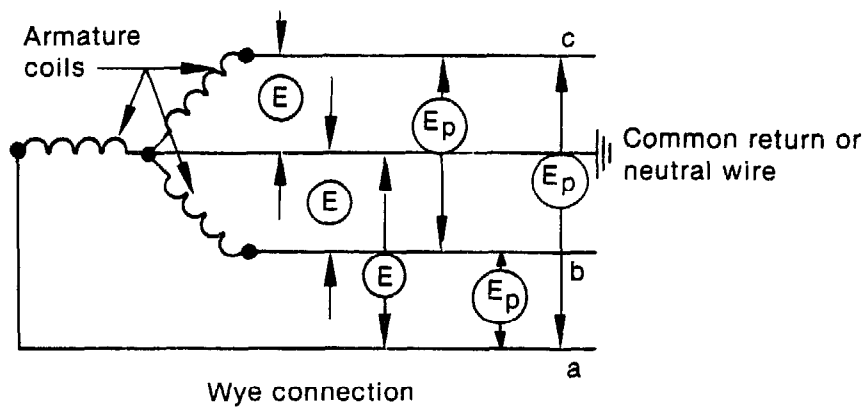

Wye connection

E = Line to neutral voltage

E_p = Phase voltage

INEL 2 2291

Figure A6-4. Wye connection.

Delta Connection--The method of connecting of a three-phase generator so that each of the three phases carries voltage differing in phase by 120 degrees from the other two. In this connection, the coils are only common at terminal of two coils. See Figure A6-5.

Power in a delta connected system is also given by Equation (A6-11):

$$P = \sqrt{3}EI \quad (A6-11)$$

A.6-2 Generator and Motor Terminology

Magnetic Flux--The magnetic field of a magnet can be depicted by curved lines from the north to the south pole, as shown in Figure A6-6. Arrows placed on the lines that picture the condition in space, indicate the direction of the force that would be exerted on the north pole of a compass needle at that point. The density of line spacing represents the magnitude of the field. The lines that represent the condition of the space around the magnet are called the magnetic flux. The magnetic field of a motor generator rotates about the machine axis.

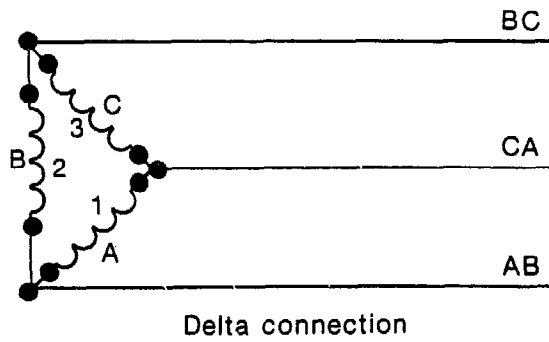

Voltage is equal on all three lines but 120° out of phase.

INEL 2 2292

Figure A6-5. Delta connection.

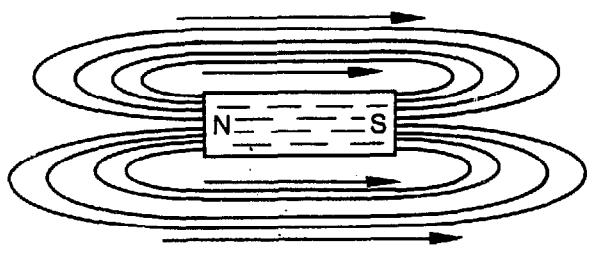

Lines of magnetic flux around a bar magnet

INEL 2 3204

Figure A6-6. Lines of magnetic flux around a bar magnet.

Torque (T)--Turning effort, expressed in foot-pounds. It is a measure of the ability of a shaft to develop power in a generator. Torque is measured in foot-pounds at full-load speed. It is equal to the horsepower multiplied by 5250 and divided by the full-load speed.

$$T = \frac{\text{hp} \times K}{\text{full-load speed}} \tag{A6-12}$$

where

T = torque, in foot-pounds

hp = horsepower

K = constant 5250

full-load speed = speed to produce full torque, in rpm.

For example, a 100-hp, 1800-rpm generator will have the following full-load torque:

$$\frac{100 \times 5250}{1800} = 291.5 \text{ ft-lb}$$

Synchronous Speed--Synchronous Speed is the speed an induction motor would reach if there were no slip. It is the speed at which the magnetic field, in effect, rotates about the stator.

$$\text{rpm} = \frac{f \times 120}{p} \quad (\text{A6-13})$$

where

rpm = synchronous speed

f = frequency in Hertz

p = number of stator poles.

The following table correlates the number of poles and synchronous speed for common motors.

Number of Stator Poles	Synchronous rpm (60 Hz)
2	3600
4	1800
6	1200
8	900
10	720
12	600
14	514
16	450

Full-Load Speed and Slip--The rotor of an induction motor or generator can never run quite at synchronous speed because the magnetic field must lead the induced magnetic field of the rotor. The difference between synchronous speed and operating speed is known as slip. This is usually expressed in percent of synchronous speed.

$$\text{Percent slip} = \frac{(\text{synchronous speed} - \text{operating speed}) \times 100}{\text{synchronous speed}} \quad (\text{A6-14})$$

where

synchronous speed = speed determined by Equation (A6-13).

operation speed = actual measured speed of the generator = full-load speed.

For example, a 200-hp, 6-pole, 60-Hz generator may have a full-load speed of 1280 rpm. The synchronous speed would be 1200 rpm.

$$\text{Percent slip} = \frac{(1200 - 1280) \times 100}{1200} = -6.7\%$$

Overspeed--The condition, in a hydropower production system, in which the generator is driven without an electrical load connected to it, and the turbine is producing torque under no-load conditions. When this condition exists, the turbine may reach speeds two to three times normal or greater.

The generator would be driven at the same speed ratio that the turbine is turning.

Overspeed conditions can damage the generator due to the heat in the generator from high current flows and from the higher speed of the parts and bearings.

Governor--A device to control or govern the speed of a generator unit.

Efficiency--The measure of the generator's ability to convert mechanical input to electrical output.

The kilowatt is the common unit of electrical output, and the horsepower is the common unit of mechanical input. In Section 3 of the handbook, the relation of horsepower and kilowatts was developed to show that

746 W = 1 horsepower or

1 kW = 1.34 horsepower.

In an ideal machine, power in = power out. However, in a real generator there are power losses. The recognized machine losses are

- Stator no-load iron loss
- Stator copper loss (I^2R)
- Stray load loss
- Rotor copper loss (I^2R)
- Friction and windage

A generator's efficiency is given by

$$\text{Efficiency} = \frac{\text{output}}{\text{input}} = \frac{\text{input} - \text{loss}}{\text{input}} \quad (\text{A6-15})$$

For example, if a generator has an output of 100 kW and an input of 149 hp, efficiency will be as follows:

$$\text{Output} = 100 \text{ kW}$$

$$\text{Input} = 149 \times 0.746 = 111.1 \text{ kW}$$

$$\text{Efficiency} = \frac{100}{111.1} = 90\%$$

The losses will be $111.1 \text{ kW} - 100 \text{ kW} = 11.1 \text{ kW}$.

Insulation--A nonconducting material used to separate two current-carrying conductors. Insulations are usually specified on the basis of heat and voltage ratings. Insulations used in generators will be explained later.

Magnetizing or Exciting Current--Generators, motors, and other electrical apparatus with magnetic circuits containing iron must be magnetized in order to operate. It is often convenient to speak of the input current as having two components: a load component in phase with the voltage, and a magnetizing component at right angles and lagging the voltage. This lag would be 90 electrical degrees. See Figure A6-7.

The load component or kW registers on the watt-hour meter and does the actual work. The magnetizing component puts energy into the magnetic circuits of the apparatus during one quarter cycle and returns it to the electrical system during the next quarter cycle. This is illustrated in Figure A6-7 where positive and negative areas representing power are equal and cancel out. Except for losses, the net power interchange due to the magnetizing component is zero.

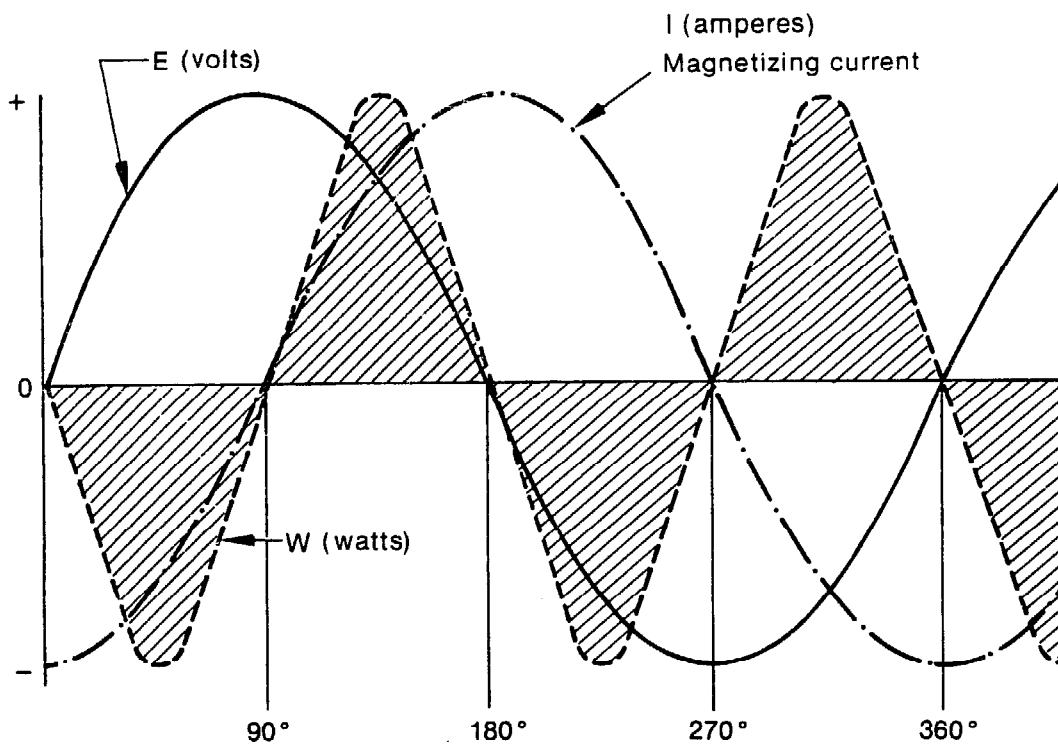

INEL 2 3205

Figure A6-7. Magnetizing current components.

Mathematically:

$$I_t = \sqrt{I_r^2 + I_x^2} \quad (A6-16)$$

where

I_t = total line current

I_r = in-phase (power) component

I_x = out-of-phase (magnetizing) component.

Also,

$$kVA = \sqrt{(kW)^2 + (kVAR)^2} \quad (A6-17)$$

where

kVA = total kVA

kW = load component

kVAR = reactive component (magnetizing kVA).

Rotation (Rot)--Used to describe the direction in which the shaft turns: CW = clockwise, CCW = counterclockwise, Rev = reversible.

Service Factor (SF, Svc Fctr)--A measure of the reserve margin built into a motor or generator. Motors rated over 1.0 SF have more than normal margin and are used where unusual conditions, such as occasional high or low voltage, momentary overloads, high ambient temperatures, etc., are likely to occur. If needed, it is specified when the machine is ordered.

Ambient (Amb)--Ambient temperature is the temperature of the space around the motor or generator. Most motors are designed to operate in an ambient temperature of not more than 40°C (104°F). Note: A rating of 40°C ambient is not the same as a rating of 40°C Rise; see the next paragraph, "Temperature Rise."

Temperature Rise--The amount by which a motor or generator, operating under rated conditions, is hotter than its surroundings. Increasingly, manufacturers are replacing the rise rating on the nameplate with a listing of the ambient temperature rating, insulation class, and service factor.

Frame--The frame size usually refers to the National Electrical Manufacturers Association (NEMA) system of standardized motor or generator mounting dimensions, which facilitates replacement.

Full-Load Amps (F/L Amps)--The line current (amperage) produced by a generator when operating at rated load and voltage. Full-load amps are shown on the nameplate. This information is necessary for proper wire size selection.

Poles--The number of magnetic poles set up inside the motor by the placement and connection of the windings.

Coil--Coil refers to the windings of a generator. The leads for these coils are brought out to the wiring terminals. Connections at these terminals determine the voltage that is produced. For example on a 230/460-V, single-phase generator, the terminal connections would be as shown in Figure A6-8.

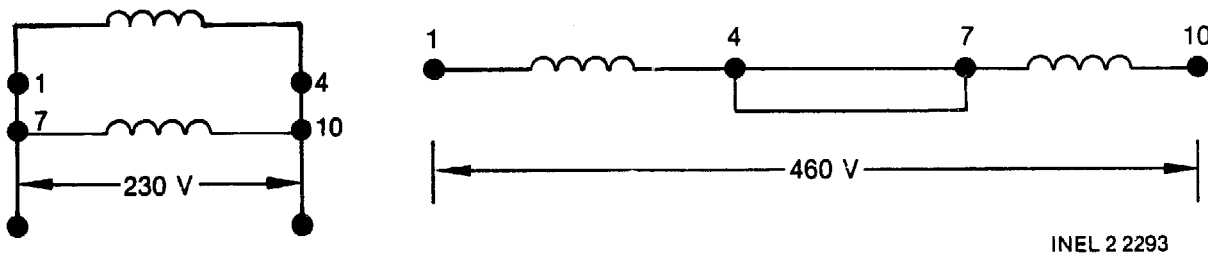

Figure A6-8. Terminal connections of a 230/460-volt, single-phase generator.

Stator--In a generator, the stationary coil in which electricity is produced; also called the field winding.

Rotor--The rotating component field of a generator; also, called the armature.

A-6.3 Generator Theory

The basic principle in physics that makes a generator produce electricity is that as a conductor is moved across a magnetic field a pressure (voltage) is developed that forces electrons to move from atom to atom. This is represented and explained in Figure A6-9.

If Conductor C in Figure A6-9 is moved by some force across the magnetic field in the direction indicated by the Arrows A-A, voltage is produced in the direction of the Arrows V-V along the Conductor C if the flux is in the direction indicated, north to south. The value of the voltage produced depends on the strength of the magnetic field and the speed at which the conductor moves through the magnetic field.

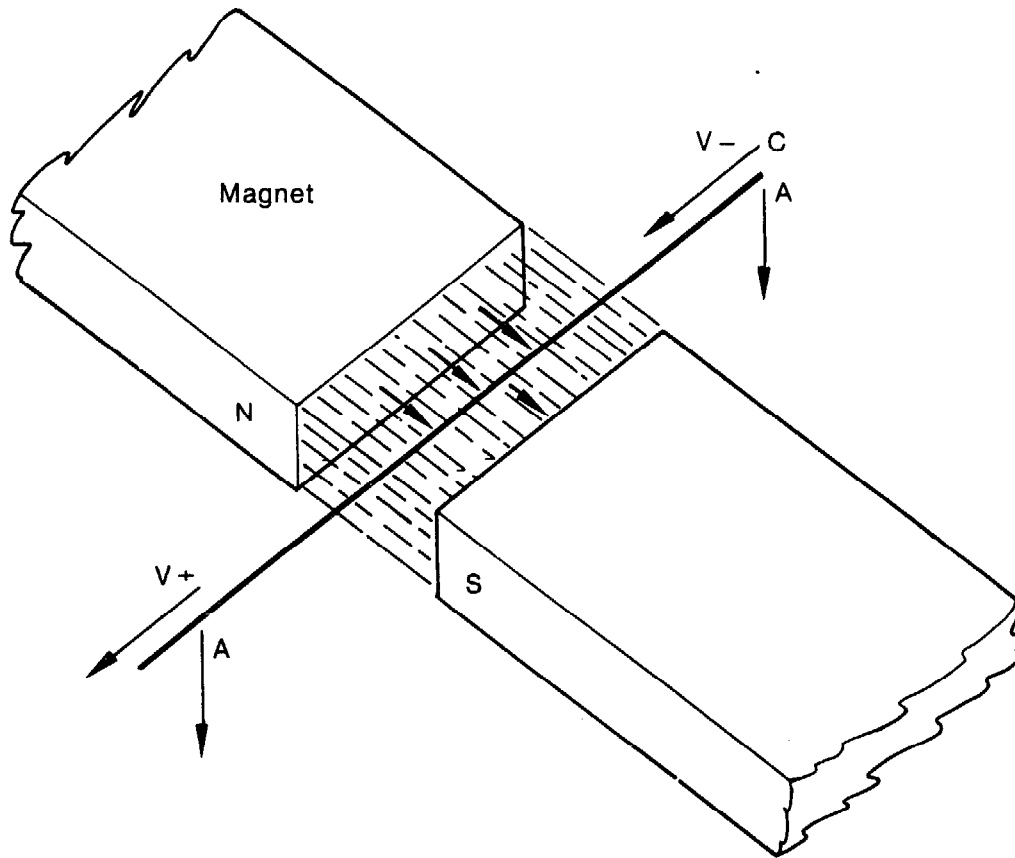

INEL 2 3209

Figure A6-9. Generation of electricity in a magnetic field.

The same voltage would be produced if the conductor were held stationary and the magnetic field were made to move across the conductor.

A-6.3.1 The Single-Phase Generator

Figure A6-10 is a simplified diagram of a single-phase electrical generator. A horseshoe-type electric magnet is used to illustrate the magnetic field. The conductor, which must pass across the magnetic lines of flux, is formed into the shape of a loop, which can be imagined to rotate on Axis X-X. The ends of the conductor are connected to slip rings mounted on the shaft. Brushes shown as B-B ride on the slip rings so that the flow of electrons is from the rotating conductor into a circuit that is external to the machine.

The brushes are usually made from blocks of carbon, which can be shaped to fit closely to the rings. They are held in place and pressed against the rings by spring devices mounted on the brush holders.

The magnetic flux is developed through the winding on the magnet core and is powered from an external direct-current source called the exciting current.

The generator shown in Figure A6-10 is a two-pole, single-phase, revolving-armature, alternating-current generator. The magnetic circuit produced by the coils of wire around the iron core is called the field of the generator. The rotating loop is called an armature.

When a microhydro turbine is connected to the looped conductor, driving the conductor across the lines of flux, a voltage is developed that causes the electrons to flow out to the slip rings, through the brushes, and into the circuit.

The series of diagrams in Figures A6-11 and A6-12 show in more detail the position of the conductor loop in relation to the lines of magnetic flux in the gap. It is important to note the location of the dot on the conductor in Figure A6-11 and follow it through the diagrams because the value of the voltage generated is related to how many lines of flux the conductor is crossing at any given time. The following explanations will simplify comprehension of the process.

Assume that the conductor is rotating at a uniform speed in the direction of the curved arrows. At 0 degrees, the dot on the conductor in Figure A6-11 is moving parallel to the lines of flux, not actually crossing any of them; therefore, the voltage is zero (as shown in Figure A6-12). As the conductor rotates toward the one-quarter cycle point (90 degrees), the conductor starts to cross some of the lines and a voltage begins to develop. At the one-quarter cycle point, the conductor is crossing the maximum number of lines and is therefore generating the maximum voltage (Figure A6-12). As the dot swings toward one-half cycle (180 degrees), it crosses fewer and fewer lines, until at exactly one-half cycle the voltage is zero again (Figure A6-12). The conductor then swings down to

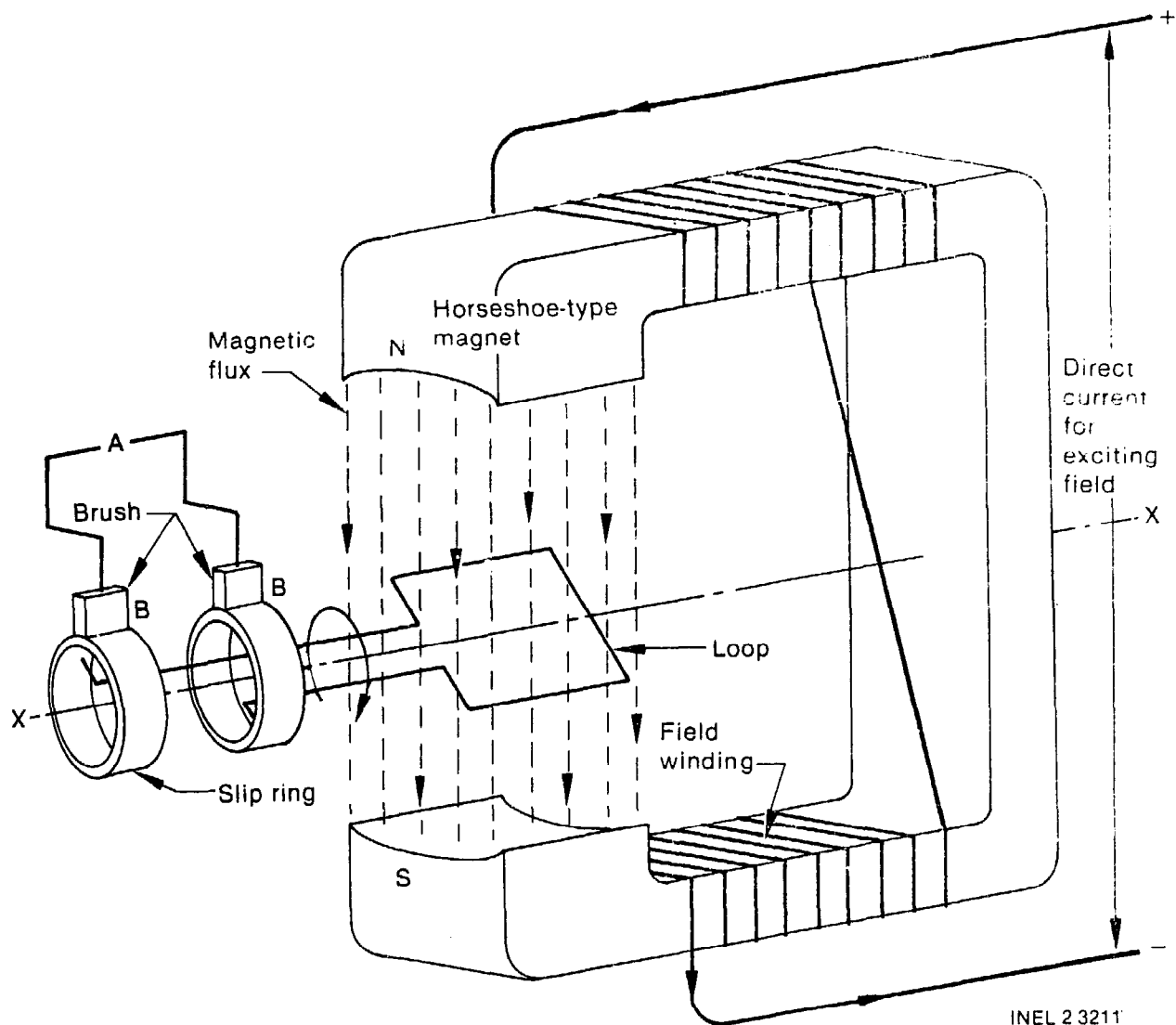
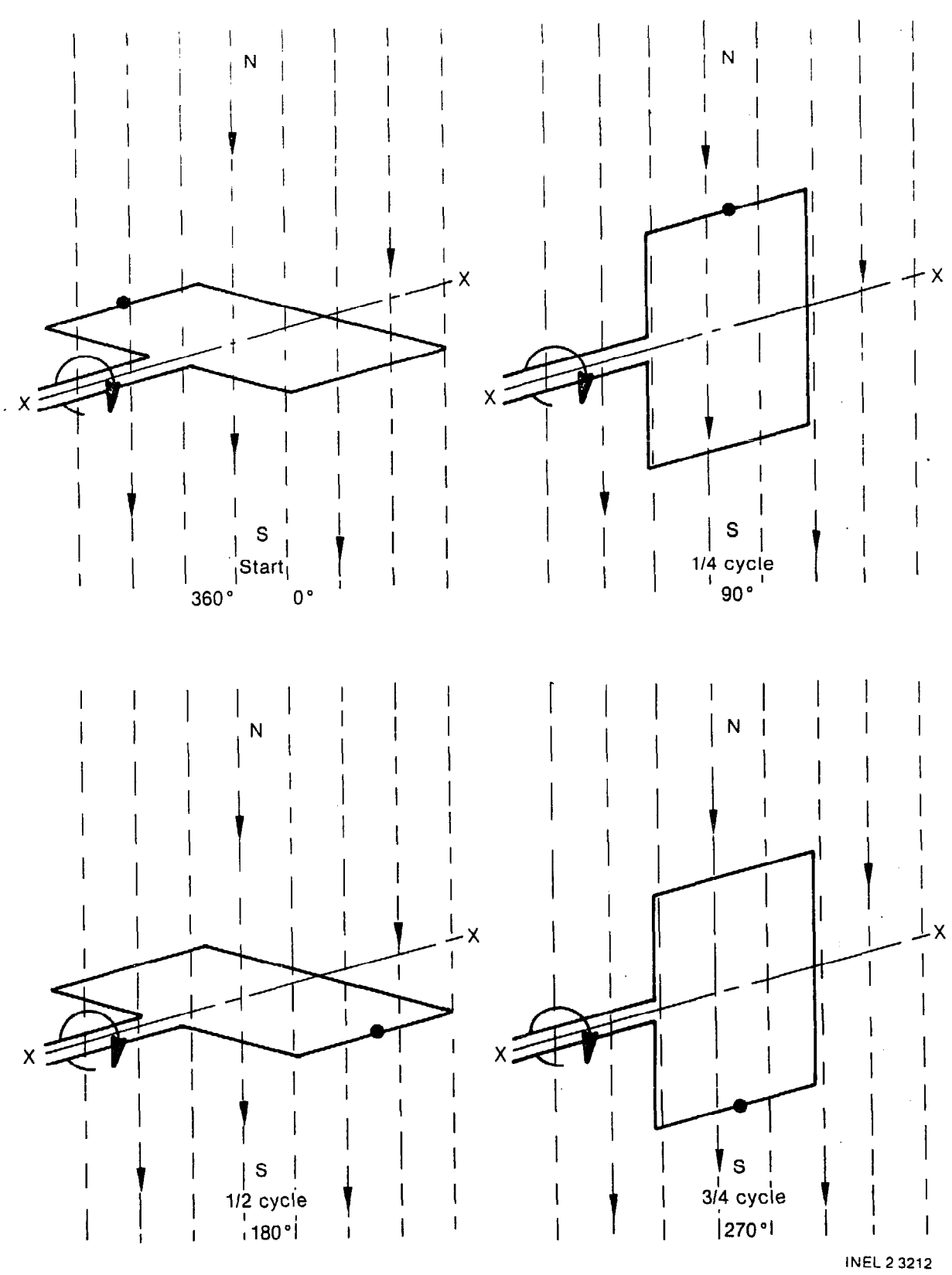

Figure A6-10. Simplified diagram of single-phase generator.

three-quarter cycle (270 degrees), crossing more lines again, until at 270 degrees it is once again at a maximum value. This time, however, it is negative with respect to that at one-quarter cycle (Figure A6-12). Finally, it turns to 360 degrees or zero, at the completion of one cycle and then begins the next cycle (Figure A6-12).

In Figure A6-11, it is important to note that a voltage is also generated in the opposite side of the loop (from the dot side) as it passes across the lines of flux. The voltage across the entire loop is the sum of the voltages in the two sections of the conductor.



INEL 2 3212

Figure A6-11. Conductor loop rotating in a magnetic field.

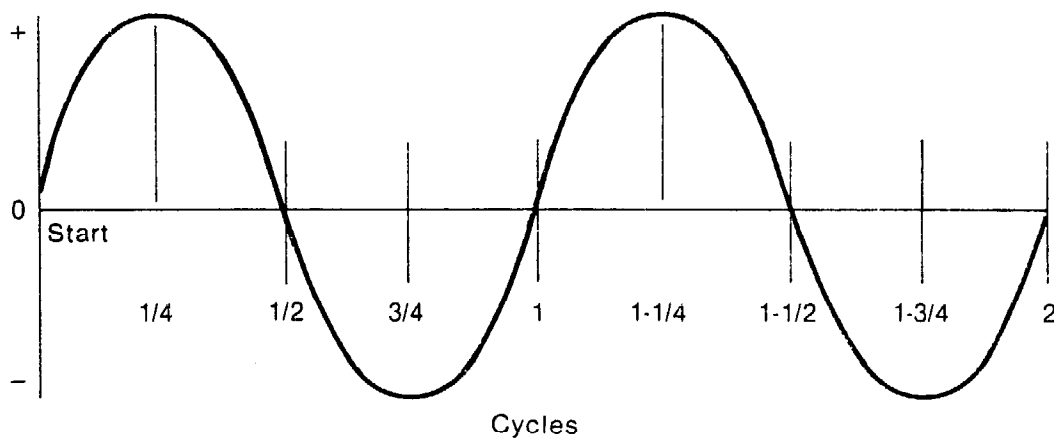

INEL 2 3206

Figure A6-12. Variation in voltage produced as conductor loop rotates in magnetic field.

If the conductor completes 60 cycles in 1 second, it is called 60 Hz voltage. The current that this voltage will cause to flow is called 60 Hz current. This is the frequency of the system.

A-6.3.2 The Three-Phase Generator

A three-phase generator is very similar to a single-phase generator, the only difference being that the three-phase generator is a combination of three loops mounted on a single shaft designed to rotate in the same magnetic field. This arrangement of coils is shown in simplified form in Figure A6-13. This figure shows that the leads are connected inside the generator. This allows only three leads to be brought out to the terminal box of the generator. Each lead serves two phases, but each phase acts independently of the others. Figure A6-13 shows the generator connected as a wye connection.

The voltages produced follow each other just one-third cycle apart because of the physical placement of the coils on the shaft and their relation to each other. When the voltage in Phase 1 is at zero, as indicated at the start point in Figure A6-14, the voltages in Phases 2 and 3 are as shown. Two cycles of voltage waveforms are tracked to show how the voltages continue one-third cycle apart.

Reproduced from
best available copy. 

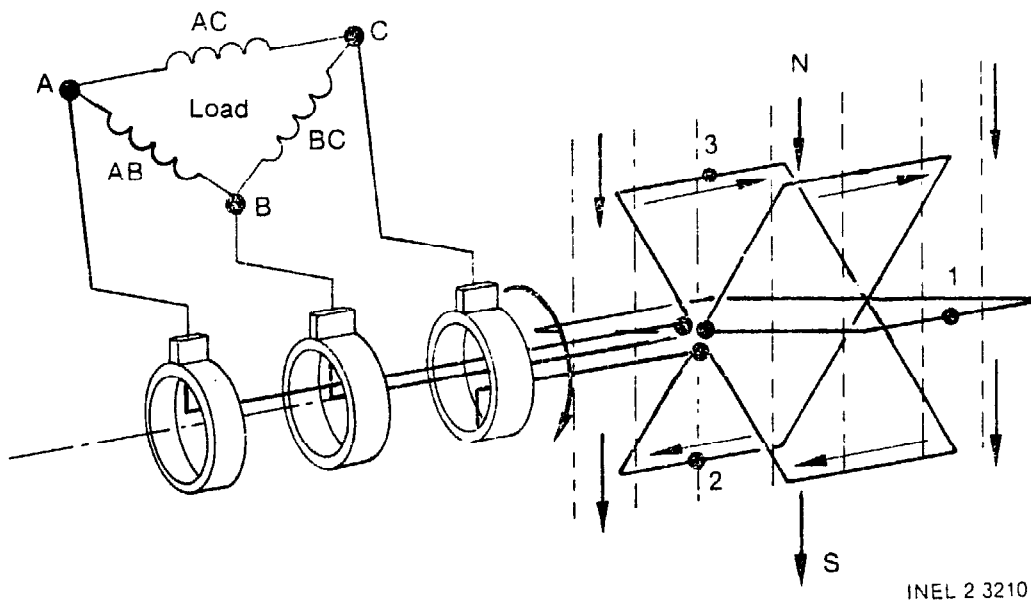

Figure A6-13. Simplified diagram of three-phase generator.

Most power systems in use today produce and transmit three-phase power because it is best adapted to motors and provides the least expensive power distribution. More than three phases are possible, of course, but it is more expensive and there is no appreciable advantage to be gained.

A-6.4 Synchronous and Induction Generators

There are two basic types of alternating-current generators used in microhydropower installations: synchronous and induction generators. These generators are constructed in the same fashion as a motor in that generators and motors both incorporate a stationary frame, the stator, containing coils to produce the magnetic flux.

A motor will develop torque on its shaft when connected to electrical power from an outside source. This same machine will generate power when torque is applied to the motor shaft from an external source. It is this application that is of interest to the microhydropower developer.

A-6.4.1 Synchronous Generators

In ac synchronous generators, the magnetic field is produced by passing direct current through a second, smaller coil of wire called the

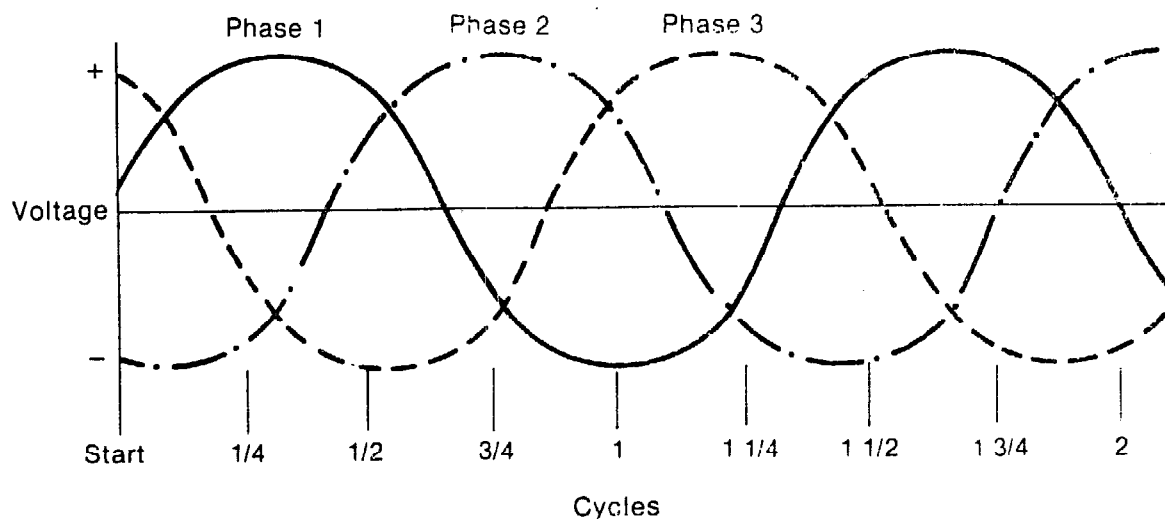

INEL 2 3203

Figure A6-14. Relation of voltage in each phase of three-phase power.

field winding. Only a small amount of current is necessary to "excite" the field coil. The coil in which the electricity is actually produced is called the armature. Since the field coil can be made appreciably smaller than the armature, the latter is often constructed on a stationary frame and the field coil made to rotate inside it.

The current required to excite the field is supplied to the rotating coil by means of collector rings. These are rings of metal that are insulated from the shaft on which the coil rides. The rings are connected to the ends of the field winding, and as they rotate with the shaft, carbon brushes make contact between them and the source of the field current.

The field current source may be an external battery or a belt- or direct-driven dc generator. It could also be a small, rotating ac generator with rectifiers.

Four-pole and six-pole field coils are commonly used. Adjacent poles are of opposite magnetic polarity, so that as the field turns within the fixed armature or stator winding, the magnetic field at any given point is

reversed each time a pole face passes. The angular velocity of the field coil can thereby be reduced for a given output frequency, since one cycle of output power is produced each time a pair of magnetic poles passes the stator coil.

There are two basic methods of producing the dc voltage required to excite a synchronous generator. The state-of-the-art method is to use a rectified ac voltage taken from the generator output. The second method is to use a dc generator mounted on the same shaft as the synchronous generator.

In small modern synchronous generators, the field current is often taken from the output of the generator itself. When the field coil is set into motion, a small amount of electricity is generally available at the generator output as a result of the residual magnetism in the field coil core material. This small current is supplied to the field coil, adding to the residual magnetic field. More electricity is then produced, and after a few rotations the full field current is flowing and full generator output is available. When operating, the field coil uses only a minute fraction of the generator output current.

Since the output of the generator is ac voltage and the field must be excited with dc, rectifiers are used to change the ac voltage to dc before applying it to the field. A rectifier is a device that exhibits a very high resistance to the flow of current in one direction and a very low resistance to the flow in the opposite direction. For practical purposes, the rectifier permits current to flow in only one direction in the circuit, thus converting ac into pulsating dc, which is adequate for field excitation. Modern generators use semiconductor rectifiers to accomplish the conversion. A separate exciter with rotating diodes permits construction of a "brushless" excitation system. Figure A6-15 is a cutaway view showing the construction details of a self-excited generator, and Figure A6-16 is a schematic of the electrical connections.

The traditional method of providing dc excitation for a synchronous generator was to use a dc generator either mounted on the same shaft as the ac generator or driven by belts. With the invention and use of

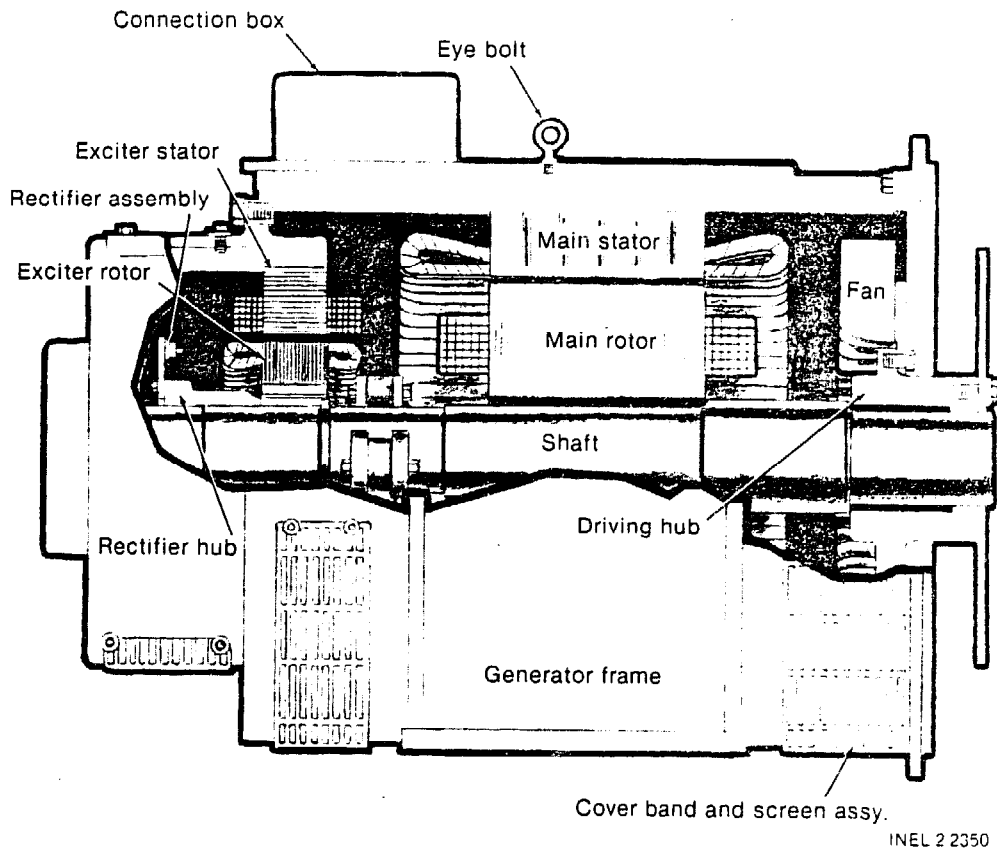

Figure A6-15. Cutaway view of self-excited synchronous generator.

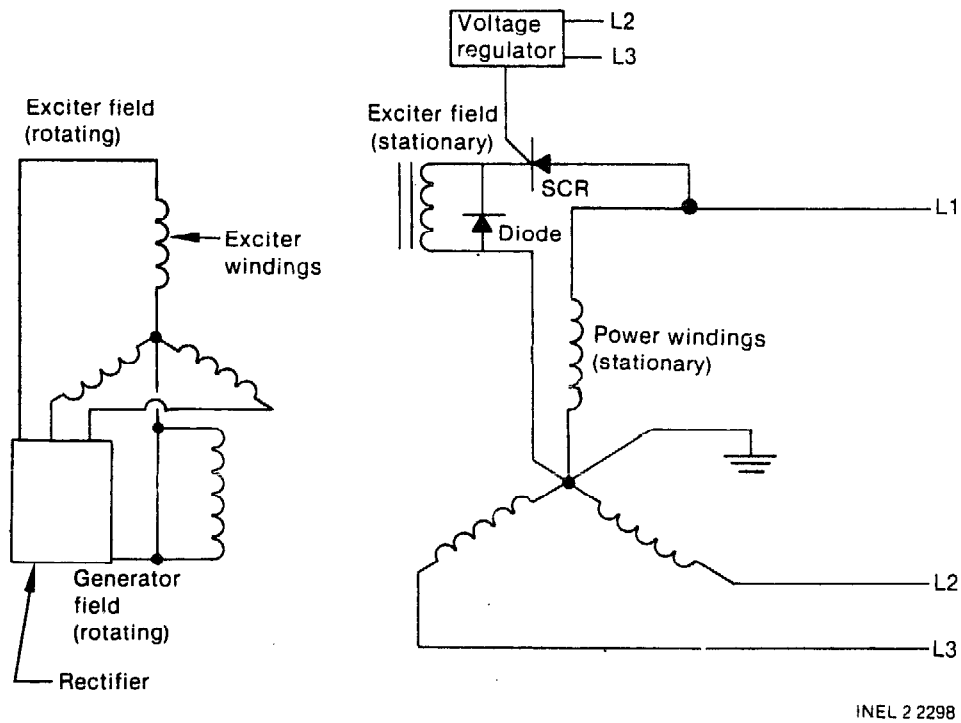

Figure A6-16. Schematic diagram of electrical connections for a self-excited synchronous generator

semiconductor rectifiers, this method is no longer economical for small generators. However, since the microhydropower developer may find an old unit with an externally excited dc exciter, this system is briefly discussed. The external dc generator is generally driven by the same source as the ac generator. The dc magnetizing current is delivered to the rotor of the ac generator through slip rings. Figure A6-17 is a cutaway view of an externally excited generator, and Figure A6-18 is a schematic of the electrical connections.

A-6.4.2 Voltage Regulation

The voltage at the output of the synchronous generator armature winding is dependent on the field coil angular velocity and the intensity of the magnetic field produced. Since it is usually desirable to maintain a constant frequency at the output of the generator, the velocity cannot be varied to adjust the output voltage. Therefore, the field current is commonly controlled to obtain the desired voltage.

In modern generators, the field current is adjusted by silicon controlled rectifiers (SCRs). These devices, like ordinary rectifiers, pass current in one direction only, but they also include a "gate" terminal to control the flow of current. When the gate terminal is not energized, the rectifier conducts no current, but when a voltage is applied to the gate terminal, current is passed in one direction until the current goes to zero. By applying gate voltage at various points on the ac cycle, pulses of current can be fed to the field to vary the average field current. During the remainder of the cycle, the magnetic field surrounds the field terminals, creating a path through which this current can flow.

The gate of the SCR is controlled by a voltage regulator circuit that senses the generator output voltage and automatically adjusts the field coil current to maintain the desired output. If a load is applied to the generator, the output voltage will drop slightly. The voltage regulator circuit causes the SCR to conduct for a longer period of time during each cycle, thus increasing the field current and restoring the output voltage to the desired level.

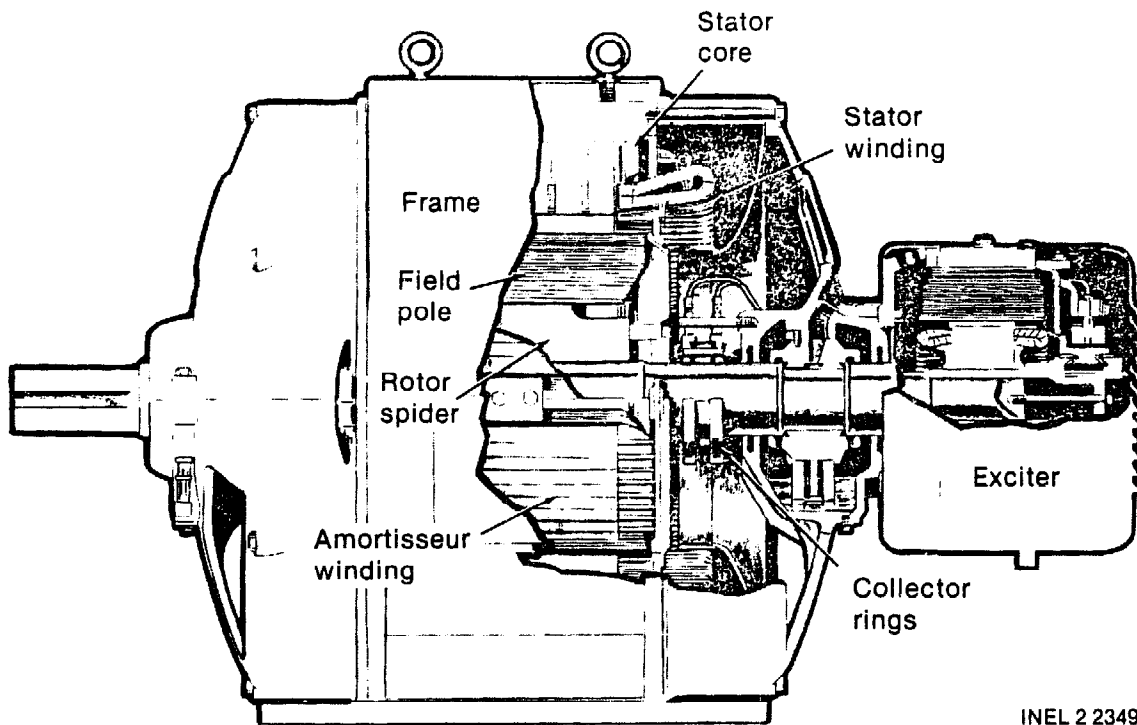

INEL 2 2349

Figure A6-17. Cutaway view of externally-excited synchronous generator.

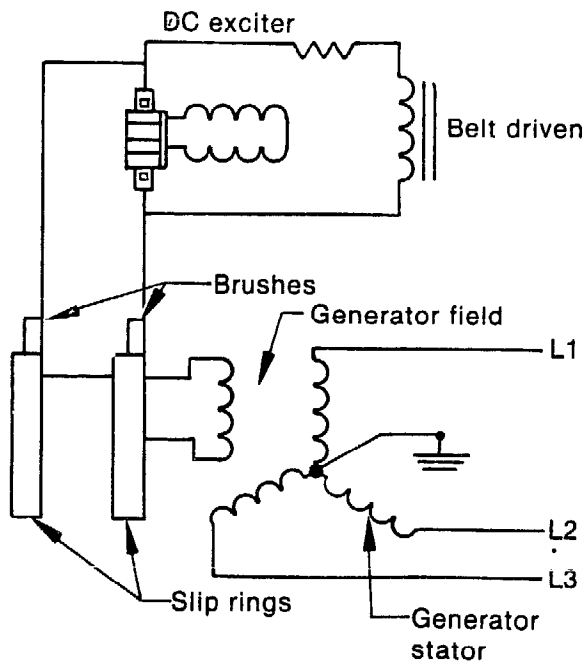

INEL 2 2294

Figure A6-18. Schematic diagram of electrical connections for an externally-excited synchronous generator.

The main advantage of the synchronous generator in microhydropower systems is that it can operate in "stand alone" situations. This generator is ideally suited for the developer who is looking for energy that is independent of a power grid.

One disadvantage of the synchronous generator is that it is more expensive than the induction generator. The main disadvantage, however, is that it requires special synchronizing equipment to tie it into a power line grid. Because of this, most experts recommend the use of induction generators in systems that tie into a utility's power lines.

A-6.4.3 Induction Generators

Induction generators have the same construction as induction motors. These generators have their stator windings, which are the source of voltage, connected to the electrical system that receives the power and their rotor windings short circuited. The machine cannot function as a generator until a revolving magnetic field has been produced in the machine, and the current that produces the rotating magnetic field must therefore be supplied to the stator windings from an external source. Consequently, an induction generator of this type must be operated in parallel with an existing power system. Such an induction generator is, in effect, an induction motor that is driven at a speed greater than that of its rotating magnetic field. Figure A6-19 is a cutaway view of an induction generator.

Suppose that an induction motor has a slip of 5% at full load when operating as a motor. If this motor is driven at a speed 5% greater than the speed of the rotating magnetic field, the flux cut by the rotor conductors will be practically the same as when it was operating as a motor. However, the direction of motion of the conductors relative to the flux will be reversed. Therefore, the machine will become a generator and deliver power to the line approximately equal to its full-load motor rating. The frequency of an induction generator is the same as the frequency of the synchronous generator with which it is in parallel.

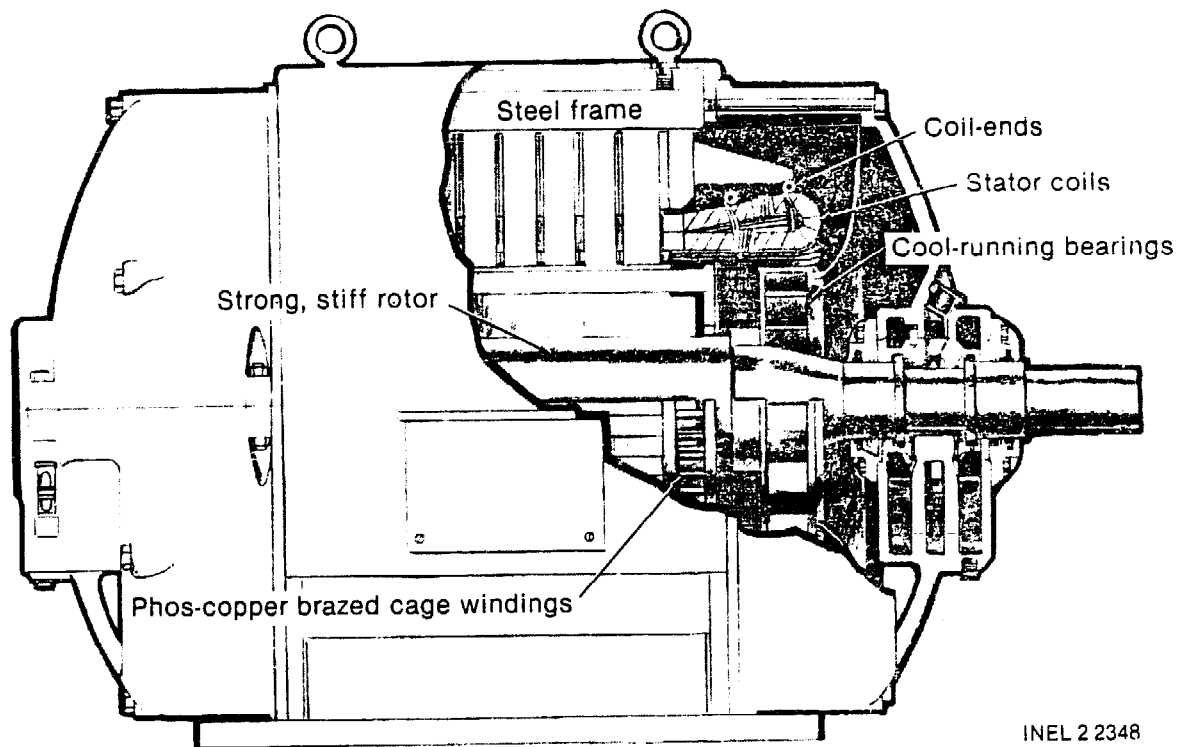

Figure A6-19. Cutaway view of induction generator.

The machine used as an induction generator is generally a readily available motor. This allows for the price break that is one of the main reasons for using an induction motor as a microhydropower generator. A second reason is that the exciting current for the system is supplied by the utility which the generator is connected.

A disadvantage of the induction generator is its inherent requirement for reactive power. It has been found that induction motors require 0.3 to 0.6 magnetizing kVA per horsepower of operating load. Therefore, when an induction motor acts as a generator, it will require the same reactive kVARs per horsepower for operation. This means that the induction generator may not be able to receive the proper magnetizing kVARs if it is located too far from the last distribution substation (more than 7 miles).

A-6.4.4 Power Factor of an Induction Generator

A poor power factor of the power grid can affect the economics of the power from an induction generator. Some utilities have a poor power factor

during certain times of the year, such as summer irrigation, because of high motor loads or other reasons. An induction generator produces power that is reactive (kVAR) and real (kW). As the reactive power increases, the real power is reduced. Therefore, the revenue production of the microhydropower station is reduced.

Most utilities require that the power factor for the generator be corrected. This factor varies between utilities, but can be from 85 to 95%. Since many induction generators operate with an integral power factor of 80%, power factor correction devices such as capacitors have to be installed on the line. Several utilities require the developer to buy the power factor devices and furnish them to the utility. The utility then installs the devices at a location that may be remote from the generator to help correct the utility's overall power factor.

The power factor at which an induction generator operates is determined by the slip and the design and does not depend on the load.

A-6.5 Generator Voltage and Connections

As a microhydropower developer, you will have to select the voltage and phasing of the generator that you desire to install.

If you are a Category 1 developer, you will want to be able to provide power for equipment at your home site. Basic electrical loads for residential use are rated 120-volt, single phase or, for larger loads, 240-volt, single phase. Some homesteads may have a particular load that will require three-phase power and if so, the microhydropower generator will have to be wired for this application.

The normal residence will require single-phase power for its loads. However, if the homeowner has three-phase power requirements, the various single phase loads can be connected to a three-phase panel and distributed to evenly balance the three-phase generator loading.

If you are a Category 2 developer, you will want to connect to a local utility. Therefore, if the utility has a three-phase power line in

the area, you will want to generate power at a three-phase voltage that can be stepped up or transformed to meet the voltage level of the utility.

If you are a Category 2 developer near a single-phase utility line, you will have to generate power at a single-phase voltage or extend your power line to the utility's three-phase line.

Generators for microhydropower electrical systems use four basic voltage configurations, which can generally be wired from the same machine by interconnecting the generator leads in various fashions. The voltages in common use are discussed in the following subsections.

A-6.5.1 Single-Phase, Three-Wire System

This is a commonly used voltage system in individual residences. Both lighting and single-phase motor loads can be served. Two-wire, 240-volt branch circuits can be used for heat and power loads; three-wire, 120/240-volt circuits for lighting outlets, split-wired duplex receptacles, and some power devices such as electric ranges; and two-wire, 120-volt circuits for lighting and receptacle outlets (see Figure A6-20).

Single-phase load generators are commonly available as small machines, with a maximum desirable rating of 5 to 20 kVA. However, most generators can be connected for single-phase generation.

A-6.5.2 Three-Phase, Four-Wire Wye System

This is the most widely used three-phase secondary distribution system. The most common use of this configuration is the 120/208-volt, three-phase, four-wire system with the neutral wire grounded (see Figure A6-21). A variety of circuits are available with this system: four-wire, 120/208-volt circuits; three-wire, 120/208-volt circuits; three-wire, 208-volt circuits; two-wire, 208-volt circuits; and two-wire, 120-volt circuits. Such a system can serve a combination of power and lighting loads and offers flexibility in circuit layout and using-equipment

application. This voltage is desirable when you are generating maximum power for personal use and for commercial resale. Most three-phase generators are rated 5 kW and above.

Another three-phase, four-wire, wye-connected system is the 277/480-volt wye-connected system (see Figure A6-22). Under certain conditions, this system offers more advantages and economy in microhydropower applications than the 120/208-volt system because it makes available two types of branch circuits: 480-volt, three-phase for motor loads; and 277-volt, single-phase for fluorescent or high-intensity discharge lighting. This voltage would be a standard voltage for the Category 2 developer who is generating maximum power for resale. With the three-phase power equation, $P = \sqrt{3}EI$, it can easily be shown that for the same power developed, the ampacity is less for a 480-volt power system than for a 208-volt system.

A-6.5.3 Three-Phase, Three-Wire Delta System

This is the common delta-connected secondary system with phase-to-phase voltage of 240, 480, or 600 volts between each pair of phase conductors (see Figure A6-23). This system can be used where the utility represents the total load. You can install a stepdown transformer to derive other voltages from the three-phase, three-wire system, but this involves other equipment and costs that must be taken into account.

A-6.5.4 Three-Phase, Four-Wire Delta System

This is a variation on the three-phase, three-wire delta system above and is commonly called a "red-leg" delta system because one phase leg is commonly painted red to differentiate it from the other two phase legs. One of the transformer secondary windings supplying the system is center-tapped to derive a grounded neutral conductor to the two phase legs between which it is connected (see Figure A6-24).

This voltage system is not a good one for microhydropower use because one phase of the generator is more heavily loaded than the others. This

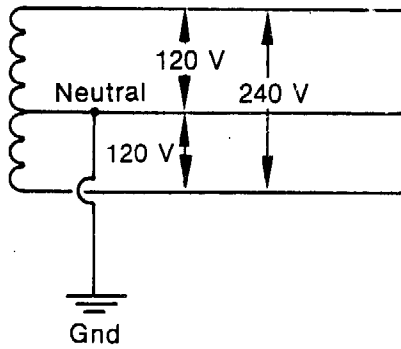

INEL 2 2295

Figure A6-20. Single-phase three-wire system.

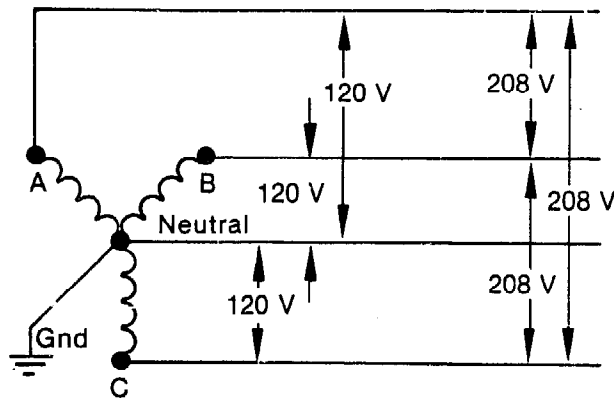

INEL 2 2296

Figure A6-21. 120/208-volt, three-phase, four-wire wye system.

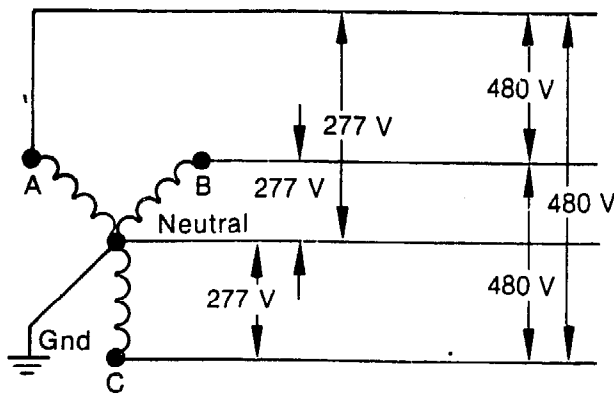

INEL 2 2297

Figure A6-22. 277/480-volt, three-phase, four-wire wye system.

will result in an unbalanced loading on the generator and may cause damage from overheating.

A-6.6 Terminal Connections

Most generators available to microhydropower developers will be the type termed "12 lead reconnectable" generators. On the basis of the above discussions, the generator can be connected for:

- 120/240 volts, single phase (Figure A6-25)
- 120/208 volts, three phase (Figure A6-26)
- 277/480 volts, three phase (Figure A6-27)
- 240 volts, three phase (Figure A6-28)
- 480 volts, three phase (Figure A6-29).

You will have to determine the voltage level best suited to your purposes and connect the unit to meet that requirement.

CAUTION--The connections shown are examples only. You should determine the characteristics of the machine to be installed and make the proper connections for that generator. Always request connection diagrams for the equipment that is purchased for the system.

A-6.7 Nameplate Data

The nameplate of a generator is a data log that describes the electrical characteristics of the machine.

Nameplates for the following generators have been included as examples:

- A synchronous alternator that is self excited and self regulated
- A brushless synchronous alternator
- An induction motor that could be used as a generator.

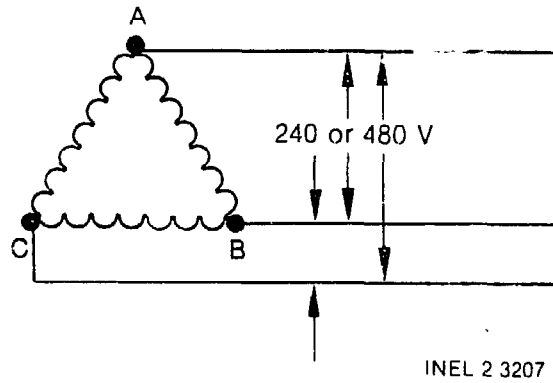

Figure A6-23. Three-phase, three-wire delta system.

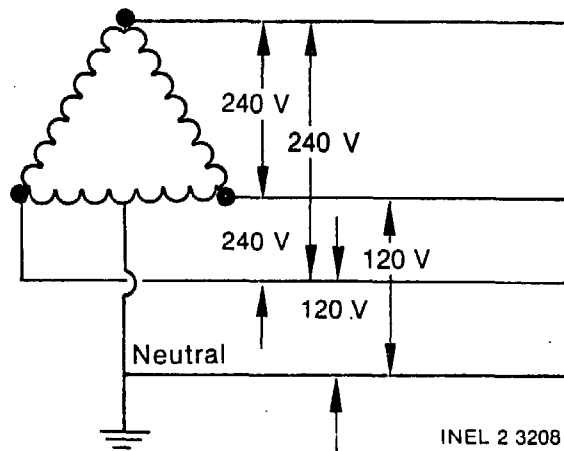
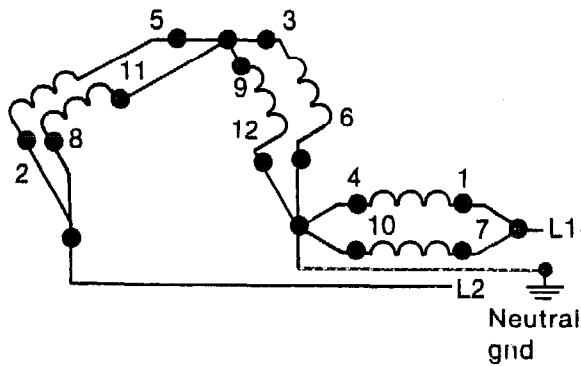

Figure A6-24. Three-phase, four-wire delta system.



120/240 V single phase 3 wire 60 Hz

INEL 2 2290

Figure A6-25. Terminal connections for 120/240 volts, single phase.

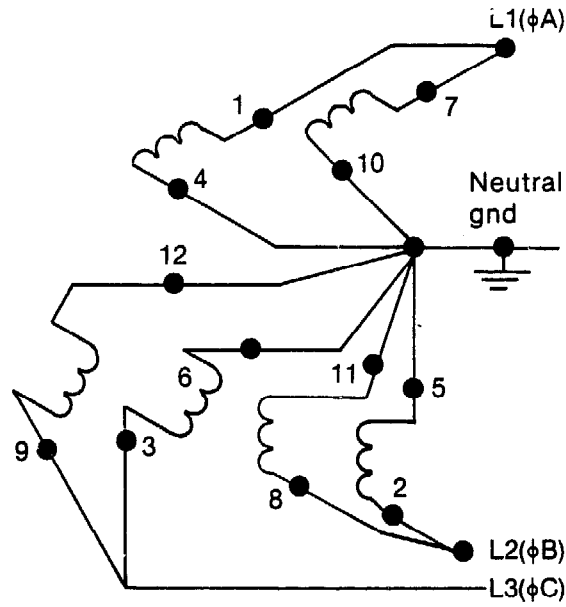

120/208 V 3 phase 4 wire 60 Hz

INEL 2 2287

Figure A6-26. Terminal connections for 120/208 volts, three phase.

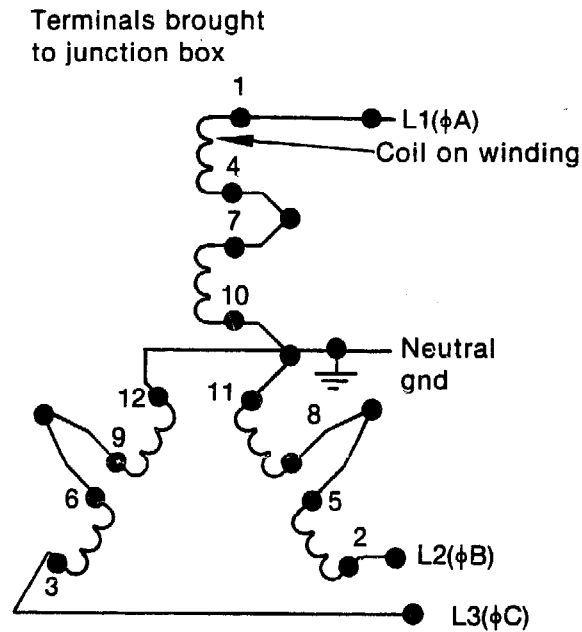

277/480 V 3 phase 4 wire 60 Hz

INEL 2 2286

Figure A6-27. Terminal connections for 277/480 volts, three phase.

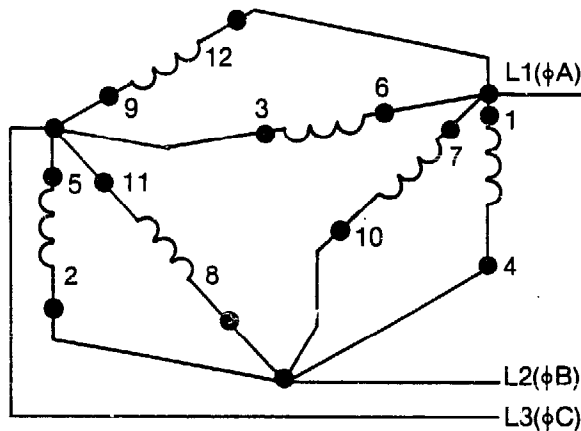

240 V delta 3 phase 3 wire 60 Hz

INEL 2 2288

Figure A6-28. Terminal connections for 240 volts, three phase.

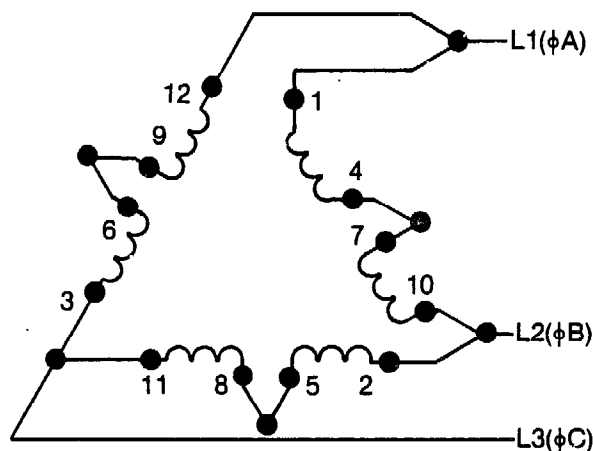

480 V delta 3 phase 3 wire 60 Hz

INEL 2 2289

Figure A6-29. Terminal connections for 480 volts, three phase.

The nameplate is a standardized metal plate issued by the manufacturer that gives information pertinent to the particular machine to which it is attached.

Nameplates can give general information regarding the manufacturer of a machine, the serial number, part number, make, and model of the machine. The nameplate can give information on agencies that approve a unit and the standards to which the unit is manufactured.

However, the important data to the microhydropower developer is the rated output, the power factor, the frequency, the phase, the voltage, and the amp rating of the unit. Temperature rise is also critical and must be considered in the system design. Figure A6-30 shows a nameplate for a self-regulated, brushless synchronous alternator. This machine is used as a self-excited, self-regulated generator. The nameplate contains information about the manufacturer and his address and affiliations, as well as his patent number.

- The symbol CSA indicates that the unit has been tested and approved by the Canadian Standards Association.
- The symbol EGSMA states that the manufacturer is a member of the Electrical Generating Systems Marketing Association.
- The SERIAL Number A 25679 UM is the manufacturer's serial number for this unit. It and the PART NO. 2782-0879 should be used when communicating with the manufacturer for information on the equipment.
- The power factor (P.F.) of this unit is 0.8. This power factor can also be figured by dividing the kW rating of the unit by the kVA rating.

$$\frac{12 \text{ kW}}{15 \text{ kVA}} = 0.8 = \text{power factor}$$

- The speed of the generator (RPM) is given as 1800. This is the speed at which the generator must be driven to provide the rated output.
- The frequency (HZ) of the generator is 60 Hz, and the (PHASE) of the unit is three phase.

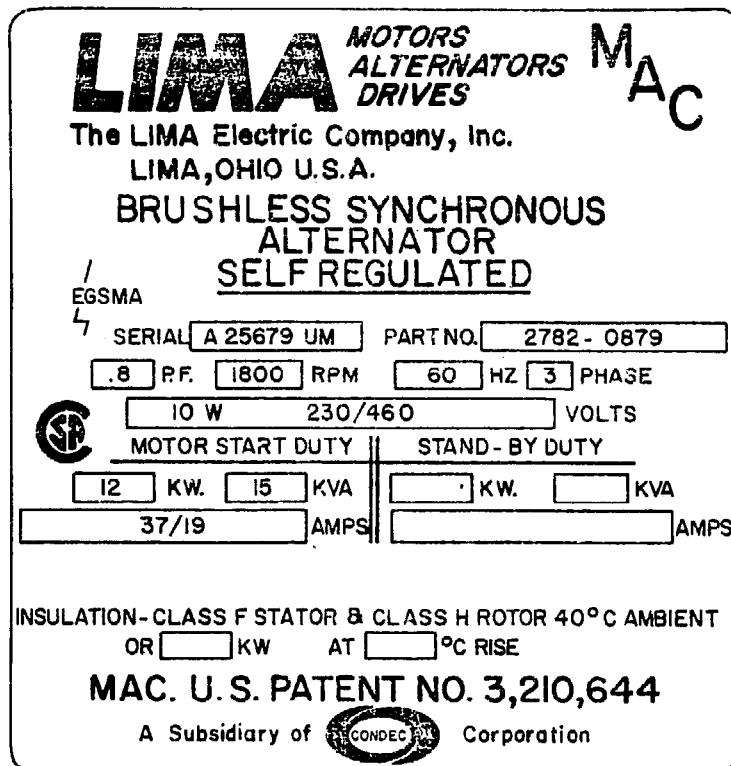

INEL 2 2273

Figure A6-30. Nameplate for a self-excited, self-regulated synchronous alternator.

- The (VOLTS) data includes the information 10 W, 230/460. This information shows that the machine is a 10-wire machine (this varies from the 12-wire machine described earlier) reconnectable for 230 or 460 volts. A connection diagram will be needed to determine the exact connection configuration.
- The numbers given under the MOTOR START DUTY column are the ratings of the unit. The kilowatt (kW) rating is 12 kW, and the kVA rating is 15 kVA. The kilowatt rating is the electrical rating of the machine. This rating is similar to a continuous-duty rating, except it shows that the unit is rated for starting heavy loads.
- The AMPS information, 37/19, is the full load amp rating of the machine at 230 volts and 460 volts, respectively.

- This nameplate also has a STANDBY DUTY RATING area. If this area were filled in, it would have indicated that the unit was rated for standby duty only and could not operate as a fully loaded microhydropower generator.

This nameplate also contains information on the INSULATION CLASS of the STATOR and the insulation class of the ROTOR. The 40°C ambient is the allowable temperature rise of the generator before it may be damaged by overheating.

The nameplate in Figure A6-31 is for a brushless synchronous alternator. The generator data are very similar to those on the nameplate in Figure A6-30.

Additional information on this nameplate is as follows:

- 12-LEAD RECONNECTABLE--this information shows that the generator has 12 leads that are reconnectable. To provide 230 V or 460 V.
- CONTINUOUS DUTY ratings of 50 kW and 63 kVA agree with the power factor rating of 0.8 pf. The 157/78 Amps rating is the full load rating at 230 V or 460 V.
- This nameplate contains an EXCITER AMP rating of 1.65 Amps and an EXCITER VOLTAGE rating of 54 volts. This is the exciter rating internal to the synchronous generator.
- The nameplate also has a place for data on a REGULATOR and the SERIAL number of the regulator. This information would be given if the regulator were matched to the machine.

The nameplate shown in Figure A6-32 is for an induction motor that could be used as an induction generator. This nameplate contains much of the same information as the nameplates for synchronous machines.

LIMA MOTORS
ALTERNATORS
DRIVES

SER

The LIMA Electric Company Inc.
LIMA, OHIO U.S.A.

**BRUSHLESS SYNCHRONOUS
ALTERNATOR**

EGSMA 12 LEAD RECONNECTABLE

SERIAL PART NO.

P.F. RPM HZ PHASE

 VOLTS

CONTINUOUS DUTY		STAND-BY DUTY	
<input type="text" value="50"/> KW.	<input type="text" value="63"/> KVA	<input type="text"/> KW.	<input type="text"/> KVA
<input type="text" value="157/78"/> AMP		<input type="text"/> AMP	
EXCITER <input type="text" value="1.65"/> AMP		EXCITER <input type="text"/> AMPS	
EXCITER <input type="text" value="54"/> VOLT		EXCITER <input type="text"/> VOLT	

INSULATION-CLASS F STATOR & CLASS H ROTOR 40°
OR KW AT °CRISE AMBIENT

REGULATOR SERIAL

A Subsidiary of  Corporation

INEL 2 2274

Figure A6-31. Nameplate for a brushless, synchronous alternator.

- The MODEL NO. B015 4DGF2U 4, the TYPE 1KK, and the FORM OBK1 are the manufacturer's identification numbers relating to this motor. This information should be used when contacting the manufacturer for data on the unit.
- The VOLTS rating of the machine is 230/460 volts and a connection diagram is given to show how to interconnect the machine at both voltage ratings.
- The HZ rating is 60 Hz.
- The CODE G indicates how hard the motor is to start.

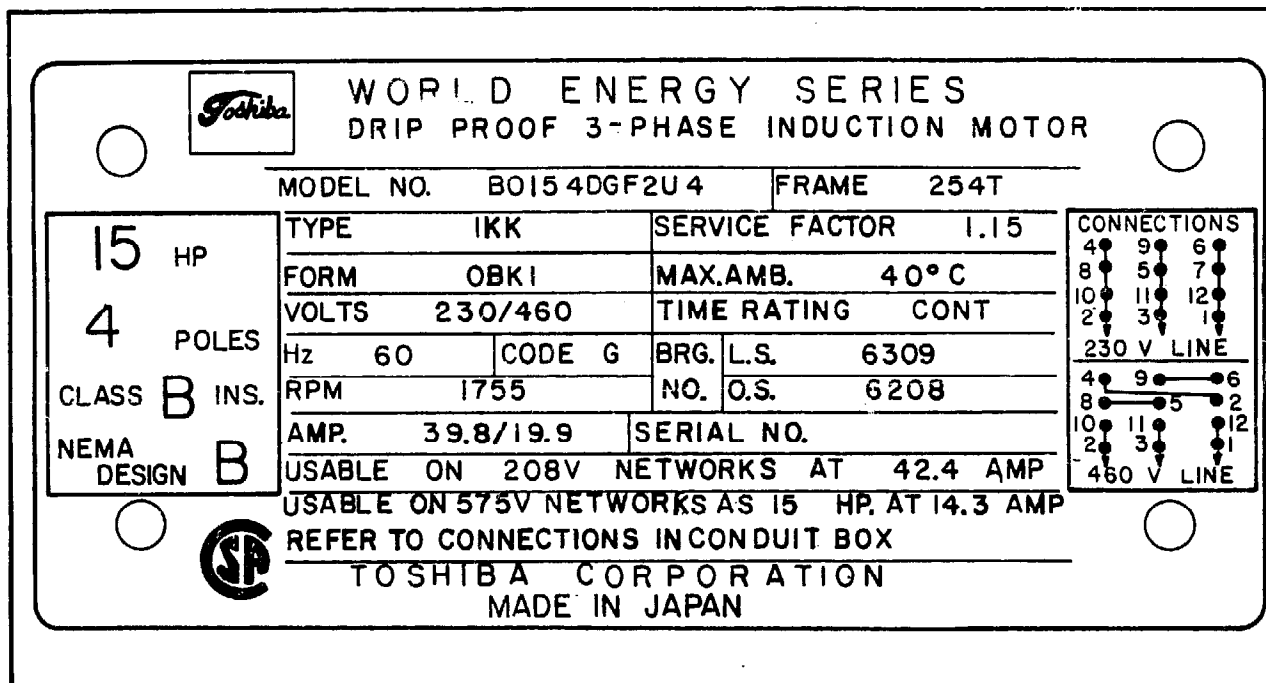

INEL 2 2275

Figure A6-32. Nameplate for an induction motor.

- The RPM is 1755. This information can be used to determine the slip of the machine from Equation (A6-16).

$$\text{percent slip} = \frac{(\text{synchronous speed} - \text{operating speed}) \times 100}{\text{synchronous speed}}$$

$$\frac{(1800 - 1755) \times 100}{1800} = 2.5\%$$

This means that to operate as a generator the motor will have to be driven at 1845 rpm.

- The AMP ratings of the motor are given as 39.8/19.9 amps. Again, these again are the full load amp ratings at 240 and 460 volts, respectively.

- The SERVICE FACTOR is 1.15, which means the generator can be overloaded for short times at a load factor of 115%.
- MAX. AMB., is the maximum ambient temperature rating of the motor.
- The TIME RATING is CONT. This means that the motor can provide 15 horsepower of power continuously without overheating at a maximum ambient temperature of 40°C.
- The motor is rated at 15 HP.
- The motor has 4 POLES.
- The insulation is CLASS B INS which describes the ambient heat of the area in which the motor can work.
- NEMA DESIGN B is the design of the motor.
- The FRAME is 245T. This is the NEMA standard frame size of this motor; it is interchangeable with other motors of a similar frame size.

A-6.8 Generator Heat and Insulation Ratings

A-6.8.1 Generator Heat

Generators are designed and rated according to their capacity to perform work, that is, by how much power they can produce for what period of time. These ratings determine the amount of heat that the generator can withstand.

A-6.8.2 Insulation Ratings

It is assumed that the temperature of the air surrounding a generator is not more than 40°C (104°F) and that the altitude does not exceed 3300 feet. The lower density of the cooling air at high altitude results

in reduced cooling. In general, however, any increase in altitude results in a lower ambient temperature, offsetting the decreased cooling effect. The total temperature based on lower ambient but a higher temperature rise, is usually about the same regardless of altitude.

Total temperature is important in that it directly affects the life of the generator's insulation. It is generally accepted that each 10°C rise in temperature will reduce the effective life of Class A or Class B insulation by about half. Actual failure of the insulation is generally mechanical, resulting from reduced strength due to continual or repeated exposure to high temperature.

An example of insulation and how it relates to temperatures in the system is: 105°C (Class A) insulation. This insulation is rated for a total allowable temperature on a material and processing system approved in AIEE #1 as being suitable for reasonable insulation life. The total allowable temperature is obtained by adding together the following temperature factors:

Ambient temperature	40°C
Temperature use by thermometer	40°C
Hot spot temperature allowance	15°C
Service factor	<u>10°C</u>
Total temperature	105°C

Class A insulation usually consists of cotton, silk, paper, or other organic materials impregnated with insulating varnish; molded or laminated phenolics; or films or sheets of synthetic resins and enamels applied to conductors.

The 15°C hot spot allowance presupposes that the hottest spot is 15°C hotter than the maximum temperature measured by an external thermometer. The 10°C service factor permits a 40°C-rise, general-purpose, drip-proof induction motor to carry 15% overload continuously without a temperature rise that would unduly damage the insulation.

Class A insulation and 40°C rise has been considered standard, but the current trend is toward single-rated motors--Class A with 50°C rise or Class B with 70°C rise.

Three standard ratings are currently in use for generators. A generator may be rated for three temperature ranges, depending on the configuration of load it is intended to carry:

- 80°C--This rating is for a generator with continuous motor loads or heavy starting characteristics
- 105°C--This rating is for continuous standard loads
- 130°C--This rating is generally given to generators for standby duty only. The standby rating is not a good rating for microhydropower systems.

Standard enclosure construction for generators used by microhydropower developers will be the open type. An open-type generator is self-ventilated, having no restriction to ventilation other than that necessitated by mechanical construction.

Dripproof generators have ventilating openings constructed so that drops of liquid or falling particles reaching the generator at an angle not greater than 15° from the vertical cannot enter the motor either directly or by striking and running along a horizontally or inwardly included surface. This is the recommended minimum protection for the majority of induction motor or generator applications.

APPENDIX A-7
TURBINE SETTING AND SPECIFIC SPEED

A-7.1 Specific Speed

The specific speed term was not used a great deal in the main body of the handbook. You will encounter this term in dealing with the turbine manufacturer or if you delve into the technical aspects of turbine design and setting. The specific speed term is a constant used to compare different turbine units and to provide a means for characterizing all units. It is defined as the speed in rpm that a runner similar to the one under consideration would attain if it were reduced to such a size that it would produce 1 horsepower under 1 foot of head at maximum efficiency. The symbol for specific speed is η_s and is calculated from the following formula:

$$\eta_s = \frac{\eta \sqrt{P}}{H^{5/4}}$$

where

- η_s = specific speed in rpm
- η = unit speed in rpm
- P = horsepower of the unit at best efficiency
- H = design net effective head in feet

As a rule of thumb, propeller reaction turbines have specific speeds from 70 to 200; Francis reaction turbines, from 20 to 100; and impulse turbines, generally below 20.

The physical meaning of specific speed is a little practical value, but is of value when comparing turbines of different types or of the same type but different designs and characteristics. The specific speed is a criterion of similarity for turbines.

Specific speed is also used to characterize pumps, although it is calculated in a different manner than for turbines. A pump specific speed is:

$$\eta_s = \frac{\eta \sqrt{Q}}{H^{3/4}}$$

where

η_s = specific speed in rpm

η = unit speed in rpm

Q = capacity in gpm

H = head in feet.

A-7.2 Turbine Setting

The location of the turbine with respect to the tailwater elevation is an important consideration in turbine selection and installation. Turbines are subject to pitting due to cavitation, which is directly related to setting. Cavitation is the formation of vapor bubbles as a result of reduced pressures as fluid flows at high velocity through hydraulic passages. When the vapor bubbles are carried into a region of higher pressure, they collapse rapidly. When this collapse occurs adjacent to the surface of a turbine, it results in the removal of a small amount of the surface. If allowed to continue, it will accelerate with time and reduce turbine life significantly. Manufacturers of turbines for large projects are asked to guarantee their turbines against excessive damage from cavitation. Excessive damage is normally defined by a rate of metal removal for a turbine:

$W = 0.6 D^2$ for mild steel turbines

$W = 0.2 D^2$ for stainless steel turbines

where

W = pounds of metal removed per 8000 operating hours

D = runner throat diameter in feet

To limit cavitation, the turbine is normally set deeper, which increases the pressure on the turbine runner and minimizes the formation of vapor bubbles. Obviously, a deeper turbine setting results in increased civil costs for the plant construction. Higher turbine speed also increases the tendency for a turbine to cavitate, but higher turbine speed results in smaller equipment and a lower cost unit. The setting depth is in general a balance between equipment cost and civil costs.

To determine the cavitation performance of a turbine, you must consider the vapor pressure of the water, atmospheric pressure, the setting of the runner with respect to the tailwater, and the maximum head at which the turbine can be operated at full gate. These factors are expressed by the Thoma Cavitation coefficient in the following relationship:

$$\sigma = \frac{(H_b - H_v - H_s)}{H} \quad (A7-1)$$

where

σ = Thoma Cavitation Coefficient

H_b = atmospheric pressure in feet of water (see Table A7-1)

H_v = vapor pressure of water in feet of water (see Table A7-2)

H_s = elevation of the runner tailwater in feet measured at the throat of a Francis Turbine, at the centerline of the blades for a vertical propeller turbine, or at the tip of the runner for a horizontal turbine (see Figure A7-1)

TABLE A7-1. ATMOSPHERE PRESSURE AT VARIOUS ALTITUDES

<u>Altitude (ft)</u>	<u>H_b (ft of H₂O)</u>
0	33.959
500	33.35
1,000	32.75
1,500	32.16
2,000	31.57
2,500	31.00
3,000	30.43
3,500	29.88
4,000	29.33
4,500	28.79
5,000	28.25
5,500	27.73
6,000	27.21
6,500	26.70
7,000	26.20
7,500	25.71
8,000	25.22
8,500	24.74
9,000	24.27
9,500	23.81
10,000	23.35

TABLE A7-2. VAPOR PRESSURE OF WATER AT VARIOUS TEMPERATURES

<u>Temperature (°F)</u>	<u>H_v (ft)</u>
40	0.28
50	0.41
60	0.59
70	0.84
80	

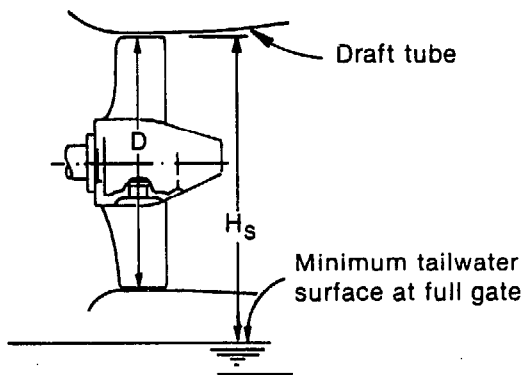
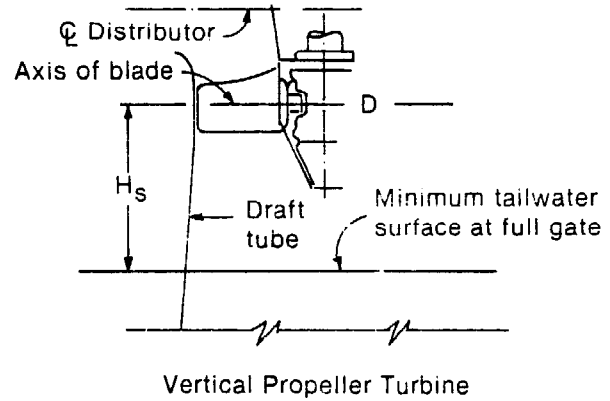
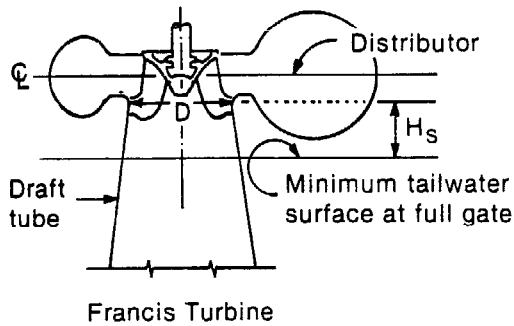

D = Minimum turbine runner Diameter

H_s = Distance from minimum tailwater surface at turbine full gate to the minimum runner diameter for vertical units or to the tip of the blade for horizontal units.

INEL 2 2666

Figure A7-1. Turbine setting coefficient definition.

H = total head on the turbine at full gate

The value of σ for any specific installation is only affected by changes to H_s or H , since H_D and H_V will be relatively constant. The value of σ at which cavitation occurs is called the critical value and is denoted by σ_c . Calculated σ values for an installation that are less than σ_c will result in cavitation in the turbine. The value of σ_c is determined by model tests of a particular runner design. In the absence of test data, the following formula can be used to calculate the minimum value of σ :

$$\sigma = \frac{\eta_s^{1.6}}{.4325} \quad (A7-2)$$

where

σ = Thoma Cavitation Coefficient

η_s = Specific speed of the turbine

Equation (A7-2) is drawn graphically in Figure A7-2 so that calculation time can be saved. By rearranging Equation (A7-1), the elevation of the runner at its throat can be calculated:

$$H_s = H_b - H_v - \sigma H \quad (A7-3)$$

It is normal practice to subtract an additional distance to ensure that the runner is placed well below the cavitation limits. A rule of thumb for small units would be 3 feet. Equation (A7-3) can now be rewritten in the following form:

$$H_s = H_b - H_v - \sigma H - 3 \quad (A7-4)$$

This method should only be used for preliminary setting of the turbine since the setting will vary with different manufacturers. These calculations can be used during the initial project stages for design of the powerhouse, calculation of needed excavation, and selection among different turbine types and designs.

Assume, for example, that you are reviewing manufacturer's data for two types of turbines that fit your site. From the site layouts and

A7-7

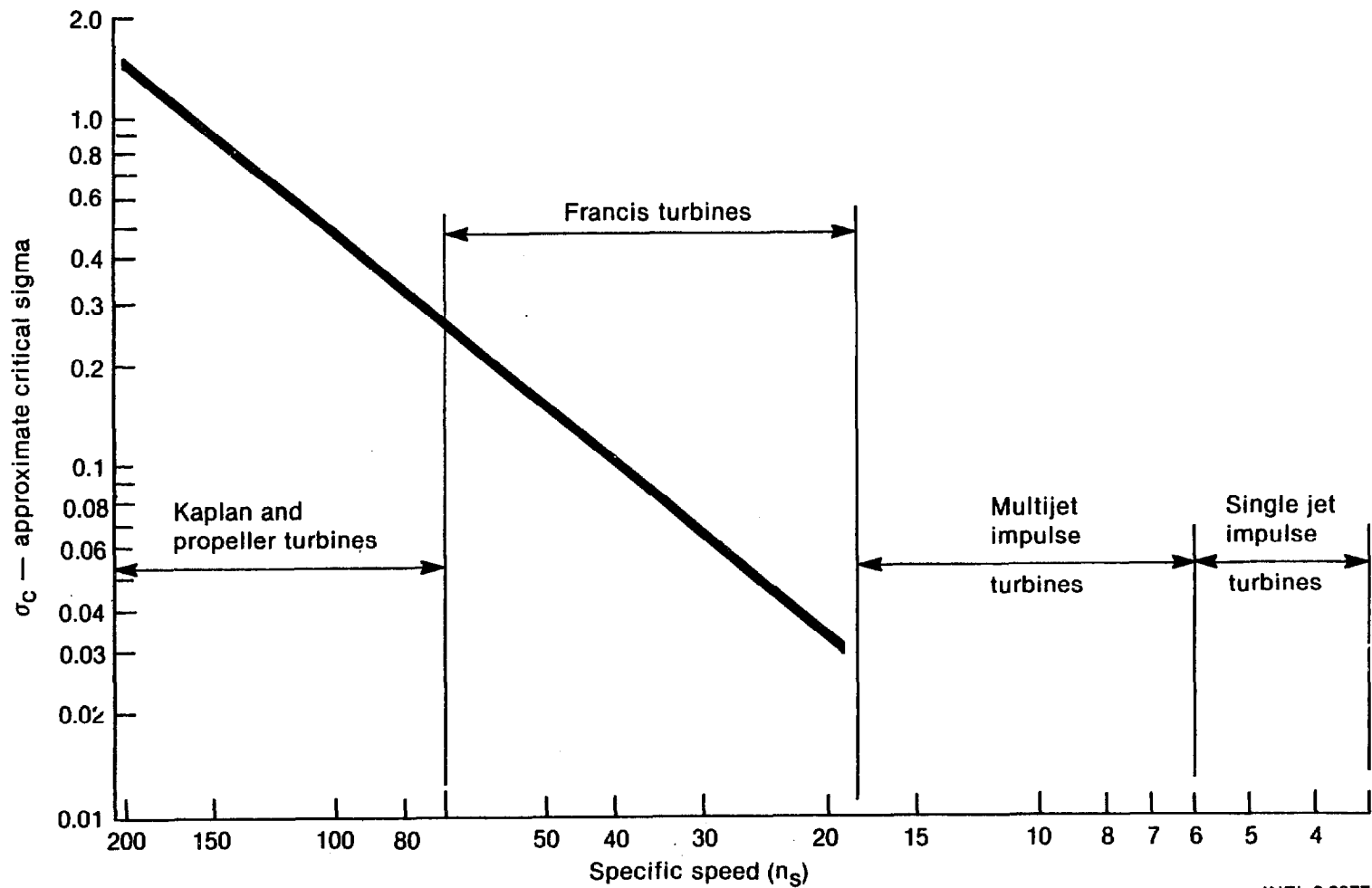

INEL 2 2677

Figure A7-2. Critical sigma.

calculations, you determine a net effective head of 60 feet across the turbine and a flow of 9.9 cfs. The first manufacturer provides a vertical Francis turbine with the following characteristics:

Runner diameter	12 inches
Power	54.0 horsepower
Speed	780 rpm
Efficiency of turbine	80%

The second manufacturer provides a vertical propeller turbine with the following characteristics:

Runner diameter	9.5 inches
Power	54.0 horsepower
Speed	1800 rpm
Efficiency of turbine	80%

The propeller turbine is small and operates at a speed at which it can directly drive a generator. It will probably be less expensive than the Francis turbine unless its high speed requires it to be set at a low elevation that requires major excavation.

Assume that your site is at 5000 feet elevation and that the water temperature may reach 50°F during the summer months. The setting of the Francis turbine can be determined using Equation (A7-4):

$$H_s = H_b - H_v - \sigma H - 3$$

where

$$H_b = 28 \text{ feet from Table A7-1}$$

$$H_v = 0.4 \text{ feet from Table A7-2}$$

$$\sigma = \frac{\eta_s^{1.6}}{4325}$$

$$H = 60 \text{ feet}$$

Determine σ_c :

$$\eta_s = \frac{\eta \sqrt{P}}{H^{5/4}} = \frac{780 \sqrt{54}}{60^{5/4}} = 34$$

$$\sigma_c = \frac{(34.3)^{1.6}}{4325} = 0.08$$

$$H_s = 28 - 0.4 - (0.08 \times 60) - 3$$

$$H_s = 20 \text{ feet}$$

This indicates that the turbine setting above tailwater level is not critical since a high setting can be used. If the site terrain is not amenable to locating the powerhouse with only the minimum draft tube length suggested in Subsection 4.1.7 without extensive excavation, a longer draft tube can be used and the powerhouse and turbine locate at a higher elevation.

The setting of the propeller turbine is calculated as follows:

$$H_s = H_b - H_v - \sigma H - 3$$

where

$$H_b = 28 \text{ feet, from Table A7-1}$$

$$H_v = 0.4 \text{ feet, from Table A7-2}$$

$$\sigma = \frac{\eta_s^{1.6}}{4325}$$

$$H = 60 \text{ feet}$$

Determine σ_c :

$$\eta_s = \frac{\eta \sqrt{P}}{H^{5/4}} = \frac{1800 \sqrt{54}}{60^{5/4}} = 79$$

$$\sigma_c = \frac{(79)^{1.6}}{4325} = 0.3$$

$$H_s = 28 - 0.4 - (0.3 \times 60) - 3$$

$$H_s = 6.84 \text{ feet}$$

The setting for this turbine is limited to a much lower elevation than the Francis turbine. If the site terrain prohibits placing the powerhouse and turbine at this elevation without extensive excavation, it may be less expensive for you to use the larger Francis turbine or attempt to find a propeller turbine with a lower specific speed.

APPENDIX B

EXAMPLE PROJECTS

B-1	RUN-OF-THE-STREAM PROJECT	B1-1
	Example Description	B1-1
	Events	B1-1
	1. Lightly Review the Handbook	B1-1
	2. Read Sections 1 and 2 and Subsection 8.1	B1-1
	3. Determine Power Requirements	B1-2
	4. Make Site Inspection	B1-2
	5. Make Initial Contact With State and Local Agencies	B1-6
	6. Make Initial Contact for Federal Land-Use Permits	B1-6
	7. Determine Available Flow	B1-8
	8. Determine Design Head	B1-16
	9. Measure Head and Distance	B1-16
	10. Go/No-Go	B1-18
	11. Determine Federal Requirements	B1-18
	12. Obtain State and Local Permits	B1-18
	13. Obtain Federal Land-Use Permits	B1-19
	14. File for FERC License	B1-19
	15. Read Section on Turbines	B1-20
	16. Contact Manufacturers and Suppliers	B1-20
	Microhydropower Turbine-Generator Information Request ...	B1-21
	17. Determine Market Potential	B1-28
	18. Determine Financing Options	B1-28
	19. Make Preliminary Cost Estimate	B1-28
	20. Go/No-Go	B1-29
	21. Select the Design Criteria	B1-29

22.	Design the System	B1-31
	Intake System	B1-31
	Alternative 2	B1-31
	Alternative 3	B1-46
	Penstock and Valves	B1-50
	Alternative 2	B1-50
	Alternative 3	B1-59
	Alternative 2 and 3 Comparison	B1-62
	Valves	B1-63
	Additional Design Considerations	B1-63
	Powerhouse	B1-63
	Tailrace	B1-66
	Generator and Electrical	B1-67
23.	Assemble the Design Package	B1-69
24.	Negotiate an Equipment Package	B1-76
25.	Make a Project Cost Estimate	B1-76
26.	Go/No-Go	B1-76
27.	Obtain FERC License	B1-76
28.	Finalize Marketing Contract	B1-76
29.	Develop Financial Package	B1-76
30.	Obtain Financing	B1-76
31.	Finalize Design	B1-80
32.	Obtain Local Building Permit	B1-80
33.	Construct the System	B1-80
34.	Operate the System	B1-81
B-2	MANMADE SITE	B2-1
	Example Description	B2-1
	Events	B2-1
	1. Lightly Review the Handbook	B2-1
	2. Read Sections 1 and 2 and Subsection 8.1	B2-1

3.	Determine Power Requirements	B2-1
4.	Make Site Inspection	B2-2
5.	Make Initial Contact With State and Local Agencies	B2-4
6.	Make Initial Contact for Federal Land-Use Permits	B2-6
7.	Determine Available Flow	B2-6
8.	Measure Head and Distance	B2-10
9.	Determine Design Capacity	B2-10
9a.	Determine Annual Energy Production	B2-12
10.	Go/No-Go	B2-13
11.	Determine Federal Requirements	B2-13
12.	Obtain State and Local Permits	B2-13
13.	Obtain Federal Land-Use Permits	B2-13
14.	File for FERC License	B2-13
15.	Read Section on Turbines	B2-14
16.	Contact Manufacturers and Suppliers	B2-14
17.	Determine Market Potential	B2-14
	Microhydropower Turbine-Generator Information Request ...	B2-15
18.	Determine Financing Options	B2-18
19.	Make Preliminary Cost Estimate	B2-18
20.	Go/No-Go	B2-20
21.	Select the Design Criteria	B2-22
22.	Design the System	B2-23
	Trashrack	B2-23
	Electrical Equipment	B2-26
	Voltage Selection	B2-30
	Wire Sizing	B2-31
	Overcurrent Protection Sizing	B2-33
	Distribution Panels	B2-33
	Service Disconnect	B2-34
	Grounding	B2-34
	Power System Interties	B2-34

23. Assemble the Design Package	B2-35
24. Negotiate an Equipment Package	B2-36
25. Make a Project Cost Estimate	B2-36
26. Go/No-Go	B2-36
27. Obtain FERC License	B2-38
28. Finalize Marketing Contract	B2-38
29. Develop Financial Package	B2-39
30. Obtain Financing	B2-39
31. Finalize Design	B2-39
32. Obtain Local Building Permit	B2-39
33. Construct the System	B2-39
34. Operate the System	B2-39

FIGURES

B1-1 Daily peak loads	B1-3
B1-2 Sketch of proposed run-of-the stream project	B1-7
B1-3 Section of stream for measuring stream flow	B1-9
B1-4 Setup for measuring stream flow	B1-10
B1-5 Sketch of diversion works	B1-34
B1-6 Sketch of diversion works and forebay	B1-36
B1-7 Elevation sketch of intake system	B1-41
B1-8 Elevation view of penstock intake structure	B1-42
B1-9 Planview of penstock intake structure	B1-43
B1-10 Pipe diameter selection graph	B1-51
B1-11 Penstock routing	B1-64
B1-12 Preliminary sketch of powerhouse	B1-65
B1-13 Three-line diagram	B1-70

B1-14	Sketch of penstock intake structure	B1-73
B1-15	Sketch of powerhouse	B1-75
B1-16	Preliminary sketch of powerhouse	B1-77
B2-1	Powerhouse requirement chart	B2-3
B2-2	Sketch of site	B2-5
B2-3	Flow duration curve	B2-11
B2-4	Flow duration curve, showing portion of flow that can be used to generate power	B2-19
B2-5	Sketch of trashrack, skimmer, and stop log	B2-27
B2-6	Three-line diagram	B2-28

TABLES

B1-1	Design specification	B1-30
B2-1	Station Number 01092000--duration table of daily values for year ending September 30	B2-7
B2-2	Flow measurement table	B2-9
B2-3	Cash flow analysis	B2-21
B2-4	Design specification	B2-24
B2-5	Final cost estimate	B2-37

APPENDIX B EXAMPLE PROJECTS

This appendix contains the step-by-step development of two microhydropower projects. The steps correspond to the events identified in Section 1.5. One project is a run-of-the-stream project and the other is a project that uses an existing dam. The characteristics of the two examples are listed in Section 2.7. The run-of-the-stream site will be considered first. Note that the cost figures included in these examples should not be used to estimate the cost of your own system.

APPENDIX B-1
RUN-OF-THE-STREAM PROJECT

Example Description

This site was described in Subsection 2.7. A review of the site description yields the following information. The site is located in mountainous terrain in Washington. The average annual temperature range is from a high of 98°F to a low of -35°F. The stream flows from a narrow canyon that opens onto a high mountain meadow. The developer's property ends at the entrance to the canyon, which is the beginning of U.S. Forest Service property. A Forest Service road provides access to the canyon and is used for logging operations. The road crosses the stream and parallels it for approximately 1/4 mile before ascending into the canyon.

Events

1. Lightly Review the Handbook

A quick review of the handbook reveals a lot of terms and equations that are unfamiliar. The developer realizes that a lot initiative is needed to study and understand the material presented.

2. Read Sections 1 and 2 and Subsection 8.1

From Subsection 1.3, the developer determines that he is a Category 1 developer whose primary objective is to provide power for two family dwellings that are currently satisfactorily supplied power from a 20-kVA/16-kW, 240-V, single-phase diesel generator. The dwellings each have electric water heaters, refrigerators, and freezers and use electric resistance heating as backup for wood heat. The dwellings commonly share a washer and a dryer and are supplied with water by a 3/4-hp, submersible well pump typically energized 10% of the time. The developer also has a small shop with a table saw, drill press, grinding wheel, and other small tools that are used an average of 3 hours a day.

Since the developer is hoping to replace a 14-kW generator, the cost may be between \$14,000 and \$56,000 (Subsection 1.2). The developer decides that the maximum investment he can afford is \$38,000.

From Subsection 2.6, the developer determines that the site is a run-of-the-stream site and can possibly use a long power canal to divert the water to the hill just above the home site.

From Section 8.1, the developer notes that the stream contains many small native fish. Since the site is in the state of Washington, water rights may be a problem. The water quality is usually clear except in high flow months, when it becomes somewhat murky. As far as the developer knows, there are no significant historical or archaeological sites above the developer's property. The only possible exception is a mine that was abandoned before World War II.

3. Determine Power Requirements (Subsection 3.1)

The developer is currently supplied electric power from a 16-kW, 240-V, single-phase diesel motor generator, and decides to stay within that power range. From a chart prepared to show daily load requirements (Figure B1-1), the developer notes that with the exception of 7:00 a.m. to 8:00 a.m., the power requirement is less than 14 kW. By adjusting the hot water demand, the system can be sized for 14 kW.

4. Make Site Inspection (Subsection 3.2)

The developer studies Figure 2-10 to determine the components that might be included in the site. Before making a visual inspection of the area, the developer prepares a list of components to insure that they are considered during the inspection.

- Stream diversion works
- Settling basin

Appliances or equipment	Watts	Hourly load schedule (Noon)																							
		1	2	3	4	5	6	7	8	9	10	11	12	1	2	3	4	5	6	7	8	9	10	11	12
RESIDENCE # 1																									
WASHER	700																								
DRYER	4600																								
3/4 hp PUMP MOTOR (10% Operation)	1000																								
ELECTRIC HEAT (Backup for Load, Assume 50% Utilization)	6000																								
COLOR TV	350																								
REFRIGERATOR	300																								
ELECTRIC RANGE (50% Utilization)	8800																								
LIGHTS	600																								
RADIO	50																								
SEWING MACHINE	100																								
IRON	1100																								
HAIR DRYER	1200																								
FREEZER	350																								
COFFEE MAKER	750																								
CLOCKS	4																								
VACUUM CLEANER	750																								
HI-FI SOLID STATE	30																								
BLENDER	600																								
ELECTRIC WATER HEATER	4000																								
RESIDENCE # 2																									
ELECTRIC HEAT (Backup for Load, Assume 50% Utilization)	8000																								
COLOR TV - 2	700																								
REFRIGERATOR	300																								
Total hourly load in kW (W ÷ 1000)																									

INEL 24108

Figure B1-1. Daily peak loads.

Appliances or equipment	Watts	Hourly load schedule (Noon)																							
		1	2	3	4	5	6	7	8	9	10	11	12												
ELECTRIC RANGE (50% Utilization)	8800																								
LIGHTS	720																								
RADIO	50																								
IRON	1100																								
HAIR DRYER	800																								
FREEZER	350	-	-	-	-	-	-	-	-	-	-	-	-	-	-	-	-	-	-	-	-	-	-		
COFFEE MAKER	750																								
CLOCKS	6																								
VACUUM CLEANER	750																								
HI-FI SOLID STATE	30																								
BLENDER	600																								
TOASTER	1100																								
KITCHEN FAN	250																								
CAR BLOCK HEATER	850																								
WATER HEATER	2000																								
SHOP																									
TABLE SAW	1000																								
DRILL PRESS	500																								
GRINDER	250																								
MISCELLANEOUS TOOLS	250																								
Total hourly load in kW (W ÷ 1000)		2.2	2.2	9.2	9.2	9.2	12.6	15.9	9.5	31	18.2	13.6	11.6	13.7	10.8	10.4	7.4	3.5	13.6	4.0	2.6	4.0	10.6	3.5	3.5

INEL 2 4107

Figure B1-1. (continued).

- Power canal
- Forebay
- Penstock intake structure.

A copy of the USGS contour map indicates that the canyon floor rises at approximately 440 feet per mile. From years of observation, the developer knows that the stream is fed by snow melt and small springs. The size of the stream varies annually from 7 feet wide and 12 inches deep to 2 feet wide and 5 inches deep. For 8 months out of the year, the stream is usually at least 5 feet wide and 10 inches deep.

During the site inspection the developer makes notes on the considerations presented in Subsection 3.2.2.

- The powerhouse can be located near the stream below the buildings. At that location, the high water marks are observed approximately 3 feet above the natural stream bed. At that height, the width of the stream would be approximately 25 feet. This would place the powerhouse approximately 250 feet from the existing diesel generator building and would require that the transmission line cross the road. The developer considers another option, locating the hydropower generator unit next to the existing diesel unit. This would eliminate the need for transmission lines. The tailrace would also add to the esthetics of the home site but would have to be routed under the road.
- A power canal is a possibility. The steepest slope would be directly up the hill behind the buildings. The canal would have to be above the rock bluff, which is approximately 100 feet above the home site. Anywhere above the bluff would be suitable for the penstock intake structure. It would be difficult but not impossible to run the penstock over and down the bluff. Equipment to be used above the bluff can be brought in along the same route that the canal would take.

- Another possibility would be to run the penstock up the valley and not use a power canal. The penstock would parallel the stream and would have to cross the road if the intake structure were to be placed on forest service property.
- There are several locations on the stream above the home site where the diversion work can be placed. Backhoe and transit mixers can reach all of these locations.
- The soil is composed mostly of sand and gravel.

The developer draws a sketch showing the alternatives considered (Figure B1-2). On the sketch, scale and accuracy were not as important as the alternative considerations for penstock routing. The USGS map was used to help locate the contour lines of the valley.

5. Make Initial Contact With State and Local Agencies (Subsection 8.2)
6. Make Initial Contact for Federal Land-Use Permits (Subsection 8.3.3 and Appendix C)

The developer now writes letters to the following agencies, to inform them of his intent, as recommended in Subsection 8.2.

- The Washington State Energy Office (WSEO) (Appendix E-8)
- The Washington Department of Game (WDOG) (Appendix E-5)
- The Washington Department of Ecology (WDOE), Office of Water Programs (Appendixes E-1 and E-4)
- The U.S. Forest Service (USFS) (Appendix D-5)
- The Washington Office of Archaeological and Historical Preservation (WOAHP) (Appendix E-7).

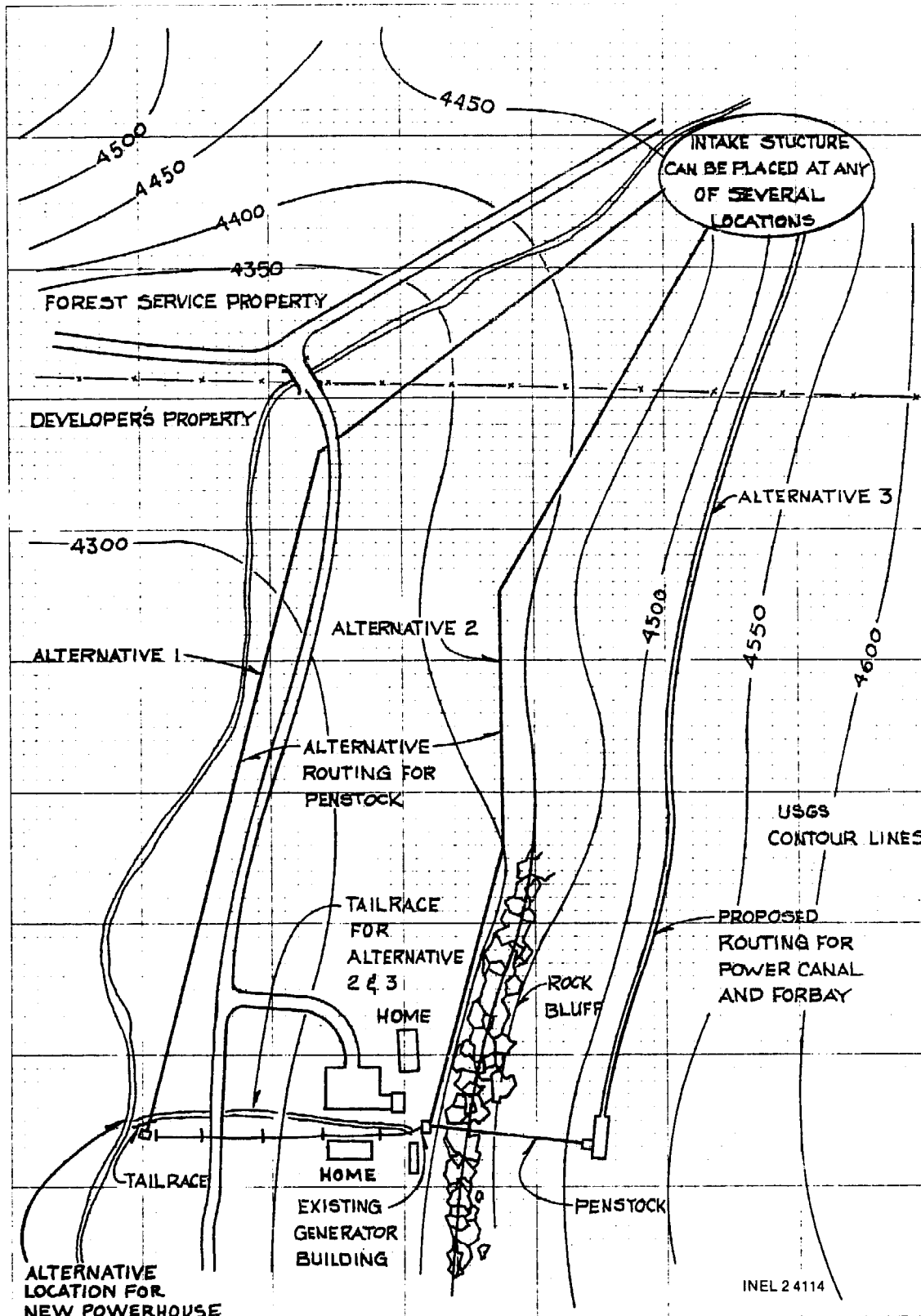

Figure B1-2. Sketch of proposed run-of-the-stream project.

The state energy office should be contacted first, since that office can always tell the developer what other agencies need to be contacted.

The developer's initial contact with the WSEO tells him that he needs to contact WDOG, WDOE, and USFS. Since WSEO also handles the water rights for the State of Washington, the correspondence also indicates that a nonconsumptive water right is required.

Initial contact with the WDOG tells the developer that 1/2 of the available stream flow must remain in the stream bed to support the fishery resource in the stream.

Initial contact with the WDOE simply requires that a questionnaire be completed and returned.

Initial contact with the USFS tells the developer that he must apply for a special use permit to build any structures on USFS land.

Correspondence from the WOAHP informs the developer that no historical or archaeological sites are jeopardized by the project.

7. Determine Available Flow (Subsection 3.3)

The developer is a Category 1 developer who is familiar with the stream and decides to use Appendix A-2, "Estimating Minimum Stream Flow," to determine how much flow is available for development. The developer first reads both Appendix A-2 and Section 3.3.3.1.3.

The steps in Appendix A-2 are followed as noted:

- A fairly straight section of stream is selected for the measurements. The stream parallels the U.S. Forest Service road providing easy access. Stakes are driven into the ground on each side of the stream for both the upper and lower crossings. The crossings are spaced 37 feet apart (Figure B1-3).

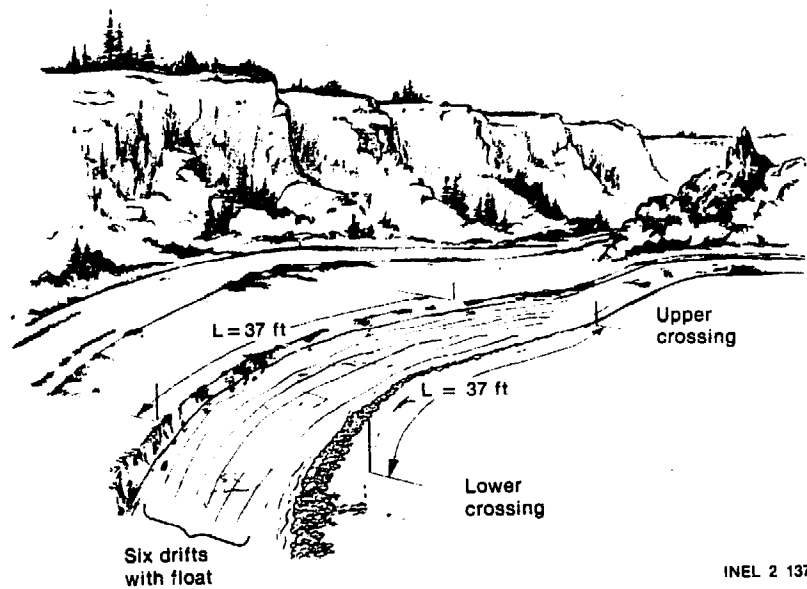

Figure B1-3. Section of stream for measuring stream flow.

At each crossing, a wire is stretched across the stream and leveled with a carpenter's line level.

- At the upper crossing, the developer estimates the location of the low-flow mark in the stream bed and drives a stake into the stream at that location. The distance from the wire to the stream bed (m_1) is measured and recorded (Figure B1-4).

$$m_1 = 31\text{-}3/4 \text{ in.}$$

Across the stream, the developer drives another stake in the stream bed where the depth also measures 31-3/4 inches.

The process is repeated at the lower crossing, with the distance measurement recorded as

$$m_2 = 27\text{-}3/4 \text{ in.}$$

- The distance between the low-flow marker stakes is measured for both crossings.

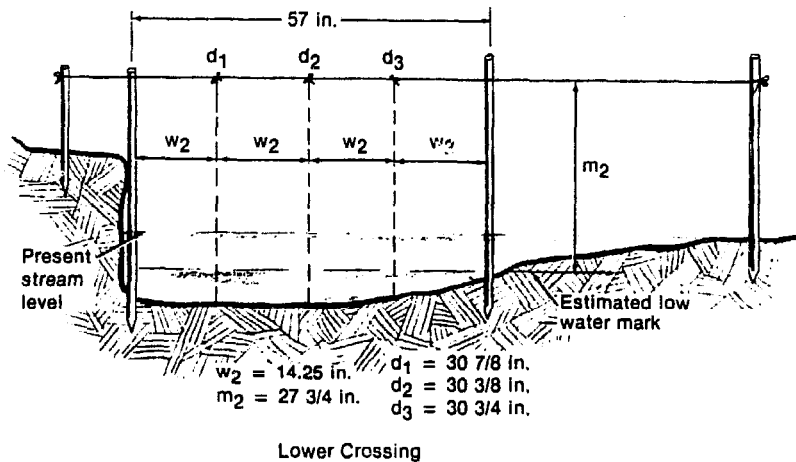
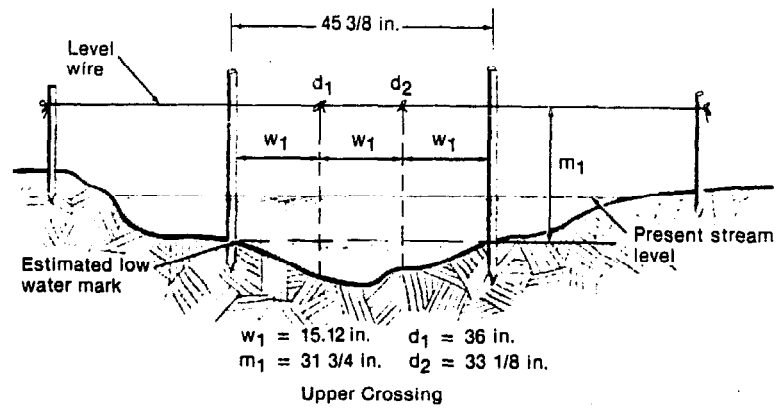

INEL 2 1364

Figure B1-4. Setup for measuring stream flow.

Upper Crossing = $45\text{-}3/8$

Lower Crossing = 57

The crossings are divided into equal segments as follows:

Upper Crossing

$45 \div 12 = 3.75$; use 3 segments

$45\text{-}3/8$ is entered into the calculator as 45.38 ($3 \div 8 = 0.38$)

$45.38 \div 3 = 15.12$ inches

For the upper crossing, $w_1 = 15.12 \text{ in.}$

Lower Crossing

$57 \div 12 = 4.75$; Use 4 segments

57 is entered into the calculator

$57 \div 4 = 14.25$ inches

For the lower crossing, $w_2 = 14.25$ inches

To measure off the segments on the wire, the developer first finds the fraction for 15.12 and 14.25.

For the upper segment

$$0.125 = 1/8 \text{ (use } 1/8\text{)}$$

Therefore, the upper segments are measured at $15-1/8$ inches each.

For the lower segment

$$0.25 = 1/4 \text{ (use } 1/4\text{)}$$

Therefore, the lower segments are measured at $14-1/4$ inches each.

A string is tied on the wire at each segment measured.

- Next, the depth of the water from the wire to the stream bed is measured at each segment marker (string).

Upper Crossing

$$d_1 = 36 \text{ in.}$$

$$d_2 = 33-1/8 \text{ in.}$$

Lower Crossing

$$d_1 = 30-7/8 \text{ in.}$$

$$d_2 = 30-3/8 \text{ in.}$$

$$d_3 = 30-3/4 \text{ in.}$$

- Now, six drifts are made at various locations in the stream.

$$t_1 = 5.4 \text{ sec}$$

$$t_4 = 5.3 \text{ sec}$$

$$t_2 = 5.2 \text{ sec}$$

$$t_5 = 5.2 \text{ sec}$$

$$t_3 = 5.3 \text{ sec}$$

$$t_6 = 5.5 \text{ sec}$$

- At this point, the following data should have been recorded on the note pad.

Upper Crossing

$$m_1 = 31-3/4 \text{ in.}$$

$$d_1 = 36 \text{ in.}$$

$$w_1 = 15.1 \text{ in.}$$

$$d_2 = 33-1/8 \text{ in.}$$

Lower Crossing

$$m_2 = 27-3/4 \text{ in.}$$

$$d_1 = 30-7/8 \text{ in.}$$

$$w_2 = 14.25 \text{ in.}$$

$$d_2 = 30-3/8 \text{ in.}$$

$$d_3 = 30-3/4 \text{ in.}$$

Drift Times

$$t_1 = 5.4 \text{ sec}$$

$$t_4 = 5.3 \text{ sec}$$

$$t_2 = 5.2 \text{ sec}$$

$$t_5 = 5.2 \text{ sec}$$

$$t_3 = 5.3 \text{ sec}$$

$$t_6 = 5.5 \text{ sec}$$

- The sum of the depth is determined for both crossings.

Upper crossing

$$D_1 = 36 + 33.12 = 69.12 \text{ in.}$$

Lower crossing

$$D_2 = 30.88 + 30.38 + 30.75 = 92.01 \text{ in.}$$

- The corrected depth at each crossing is calculated.

Upper Crossing

$$\bar{D}_1 = D_1 - (m_1 \times n_1) \quad [\text{From Equation (A2-1)}]$$

$$= 69.12 - (31.75 \times 2)$$

$$= 69.12 - 63.50$$

$$\bar{D}_1 = 5.62 \text{ in.}$$

Lower Crossing

$$\bar{D}_2 = D_2 - (m_2 \times n_2) \quad [\text{From Equation (A2-1)}]$$

$$= 92.01 - (27.75 \times 3)$$

$$= 92.01 - (83.25)$$

$$\bar{D}_2 = 8.76 \text{ in.}$$

- Now, the area at each crossing is calculated.

Upper Crossing

$$A_1 = \frac{w_1 \times D_1}{144} \quad [\text{From Equation (3-5)}]$$

$$= \frac{15.1 \times 5.62}{144}$$

$$A_1 = 0.59 \text{ ft}^2$$

Lower Crossing:

$$A_2 = \frac{w_2 \times D_2}{144} \quad [\text{From Equation (3-5)}]$$

$$= \frac{14.25 \times 8.76}{144}$$

$$A_2 = 0.87 \text{ ft}^2$$

- The average area is determined.

$$A = \frac{A_1 + A_2}{2} \quad [\text{From Equation (3-6)}]$$

$$= \frac{0.59 + 0.87}{2}$$

$$A = 0.73 \text{ ft}^2$$

- The average drift time is determined.

$$T = \frac{t_1 + t_2 + t_3 + t_4 + t_5 + t_6}{n} \quad [\text{From Equation (3-7)}]$$

$$T = \frac{5.4 + 5.2 + 5.3 + 5.3 + 5.2 + 5.5}{6}$$

$$T = 5.32 \text{ sec}$$

- The stream is running above average flow. Therefore, 0.6 is chosen as the correction factor.

$$T_c = \frac{T}{c}$$

[From Equation (3-8)]

$$= \frac{5.32}{0.6}$$

$$T_c = 8.9 \text{ sec (round to nearest tenth)}$$

- The velocity is determined.

$$v = \frac{L}{T_c}$$

[From Equation (3-9)]

$$v = \frac{37}{8.9}$$

$$v = 4.2 \text{ fps}$$

- The low-flow value is calculated.

$$Q = A \times v$$

[From Equation (3-3)]

$$Q = 0.73 \times 4.2$$

$$Q = 3.1 \text{ cfs}$$

WDOG has required that half the stream flow remain on the stream as the minimum stream flow. Therefore, the design flow is established as $Q = 1.5 \text{ cfs}$.

NOTE: The developer is in Category 1 with a run-of-the-stream site and selects the second series shown in Subsection 1.5.1 for Events 8 and 9.

8. Determine Design Head (Subsection 3.5)

The developer follows Subsection 3.5.1, using Equation (3-13) to calculate head when the flow and power requirements are known

$$h = \frac{11.81 \times P}{Q \times e} \quad (3-13)$$

where

$$P = 14 \text{ kW (from Event 3)}$$

$$Q = 1.5 \text{ cfs (from Event 7)}$$

$$e = 60\% \text{ (from Subsections 2.5 and 3.5.1).}$$

$$h = \frac{11.81 \times 14}{1.5 \times 0.60}$$

$$= 183.7 \text{ ft (Use 185 to 200 ft)}$$

The developer notes that this represents a range for the pool-to-pool head. (Pool-to-pool head is the difference in elevation from the penstock intake to the center line of an impulse turbine or to the tailwater elevation of a reaction turbine--Subsection 2.2). For the purpose of the preliminary layout, the head should range from 185 to 200 feet.

9. Measure Head and Distance (Subsection 3.3)

The developer first looks at the sketch, Figure B1-2, and the USGS contour map to determine the approximate location for the intake structure. The developer favors locating the hydropower generator unit next to the diesel unit (i.e., Alternative 2 is favored over Alternative 1). The location of the intake structure should be somewhere below the 4,550 feet contour line since the power house is just below the 4,350 feet contour (Figure B1-2).

For Alternative 2, the survey is started by sighting the penstock route and placing marker stakes along the route. A hand level is then used for the level survey. The survey is started at the existing power house. A sample of the survey log is shown below:

SURVEY LOG (measurement in feet)

<u>BS</u>	<u>FS</u>	<u>BS - SF</u>	<u>Total</u>
8.75	4.25	4.50	4.50
8.15	3.25	4.90	9.50
6.25	5.30	0.95	197.85
6.55	5.35	1.20	198.80
			200.00

Since the range of head has been calculated to be between 185 and 200 feet, a permanent stake is driven into the ground at those locations. The developer uses a 12-inch 2 x 2 and drives it into the ground until the top of the stake is at the 185-foot elevation. A tall marker stake is placed next to the permanent stake and identified with a flag so that it can be located easily. The marker stakes are identified by writing the elevation and alternative on the stake: 185.00 feet, Alternative 2 and 200.00 feet, Alternative 2.

Next, Alternative 3 is surveyed to determine the location of the penstock intake structure on the hill behind the home site. Since the bluff would be difficult to survey, the developer decides to survey up the valley and then back around to the top of the bluff. On the top of the bluff, the route for the penstock is sighted and marked with stakes. The level survey is performed to indicate where on the penstock routing line the intake structure should be located. As with Alternative 2, two permanent stakes are driven into the ground to indicate the 185-foot mark and the 200-foot mark.

After the level survey is finished, the developer then follows the penstock routing for both alternatives and measures the distance between the powerhouse and the 185-foot and 200-foot marks. The distances are recorded as follows:

HEAD AND DISTANCE TO POWERHOUSE (in feet)

<u>Alternative</u>	<u>Head</u>	<u>Distance</u>
2	185.00	2800
	200.00	3200
3	185.00	400
	200.00	450

10. Go/No-Go

The developer now finds himself at the first go/no-go decision point. He determines that there is sufficient flow and head to meet the power needs. The inspection indicated that construction of the necessary waterways is feasible, and initial contact with local, state, and federal agencies did not uncover any major problems. After evaluating the information available, the developer decides to proceed with the project.

11. Determine Federal Requirements (Subsection 8.3)

The developer reads Section 8.3 and determines that his site fits the case-by-case exemption description since he is not using an existing canal, conduit, or dam. The developer writes to FERC and requests specific instructions for filing for the case-by-case exemption.

12. Obtain State and Local Permits (Subsection 8.2)

The developer applies to the state for a nonconsumptive water right. He also contacts the county building and zoning department to see what permits are required.

The developer receives the nonconsumptive water right subject to the restriction that any canals longer than 1/4 mile be lined to prevent water loss from seepage. This would represent an added expense.

13. Obtain Federal Land-Use Permit (Subsection 8.3.3)

The USFS will issue a special-use permit to the developer, but will require that any pipelines be buried, that access roads be built to all structures, and that all construction be approved and performed in such a way as to minimize erosion.

14. File for FERC License (Subsection 8.3)

The developer files an application with FERC for a case-by-case exemption. The following items accompany the application:

- Sketch of the proposed layout, including proposed head and flow requirements and prospective power generation.
- Letter authorizing the nonconsumptive water rights.
- Letter indicating no archaeological and historical preservation conflicts.
- Letter from state game office indicating minimum stream requirements.
- A copy of the special-use permit from the JSFS.

FERC returns the application stating that proof of ownership must be submitted with the application. The developer obtains a notarized copy of the real property deed and resubmits the application. FERC acknowledges receipt of the application and establishes a filing date.

15. Read Section on Turbines (Subsection 4.1)

16. Contact Manufacturers and Suppliers (Subsection 4.2)

The developer reads Subsections 4.1 and 4.2, fills out the questionnaire form from Subsection 4.2, and sends copies to several equipment manufacturers and suppliers.

MICROHYDROPOWER TURBINE-GENERATOR
INFORMATION REQUEST

1/23/83

(DATE)

GENTLEMEN:

I am interested in installing a microhydropower system. The following site specifications are supplied for your evaluation. Please review the specifications and answer any appropriate questions concerning your equipment.

My Name: Wood B. Developer
Phone No. () No phone
Project Name: N.A.

Address: P.O. Box XYZ
Colville, WA

I. REASON FOR DEVELOPMENT

(Check One)

1. I am interested in supplying my own electrical needs. I do not plan to intertie with a utility. Therefore, I will require a synchronous generator.
2. I am interested in supplying my own electrical needs. When my needs are less than the energy produced, I would consider selling to a utility. However, I want to be able to generate power independent of a utility. I therefore require a synchronous generator and speed control equipment.
3. I am interested in supplying my own electrical needs. I want to be able to sell excess power to a utility. An induction generator is acceptable since I do not care to generate power independent of the utility.
4. I am interested in generating as much power as possible for the dollar invested. However, I want a synchronous generator so that I can generate power if the utility service is interrupted.
5. I am interested in generating as much electrical power as possible for the dollar invested. I am not interested in generating independent of the utility.

II. TYPE OF SOURCE AND AMOUNT OF HEAD

(Check One)

- 1. The site is a run-of-the-stream site and can have a pool-to-pool head from 185 to 200 feet.
- 2. The site is an existing dam and has a constant/variable pool-to-pool head of _____ to _____ feet.
- 3. The site is a canal drop/industrial waste discharge and has a pool-to-pool head of _____ feet.

III. AMOUNT OF FLOW

(Check One)

- 1. The flow values are based on the attached flow duration curve.
- 2. The flow value is based on a minimum stream flow of 1.5 cfs. This is because my objective is to supply my energy needs as much of the year as I can.
- 3. The flow is available _____ months out of the year and is fairly constant at _____ cfs.
- 4. The flow values are based on monthly averages and in cfs:

Jan. _____	May _____	Sept. _____
Feb. _____	Jun. _____	Oct. _____
Mar. _____	Jul. _____	Nov. _____
Apr. _____	Aug. _____	Dec. _____
- 5. Other: See V-9, Additional Information.

IV. PERSONAL POWER NEEDS

A copy of the daily load use table is attached. The daily peak load is estimated to be 14.0 kW. Major electrical equipment is listed below.

Based on current load use.

The voltage I need is 240, and is ~~single~~/three phase.

V. ADDITIONAL INFORMATION

1. Site location and stream name Colville, WA, on Millcreek

2. Name of local utility None
Distance to nearest substation is --- miles.
3. The quality of the water is usually clear/~~murky~~/~~silt laden~~/~~muddy~~.
4. Site elevation is 4,300 feet.
5. Annual average temperature variation is from 98
to -35 °F.
6. A sketch of the site is/~~is not~~ included.
7. Existing structures or equipment that should be used, if possible, include an existing powerhouse, which currently houses the diesel generator; use of this house is desirable.

8. The proposed diameter and length of the penstock are (leave blank if not known): _____ inches in diameter, _____ feet in length.
9. Additional information to be considered: Another 50 feet of head can be obtained if the powerhouse is placed near the stream.

(TO BE COMPLETED BY MANUFACTURER/SUPPLIER)

Name of Company Turbine Supplies, Inc.
Address 3 Gateway Drive
Waterwheel, CA 91919

Phone No. (xxx) 564-3217 Date March 1, 1983

I. GENERAL COMMENTS We have only quoted on the turbine-generator per your letter. An electronic load diverter is included with the package.

II. RECOMMENDED EQUIPMENT SUPPLIED BY COMPANY

1. Turbine inlet gate or valve

Manufacturer Turbine includes a deflector plate.
Type _____
Model No. _____

2. Turbine

Manufacturer Pelton Wheel, Inc.
Type 18-inch Pelton
Model No. XYZ

3. Generator

Manufacturer Electric Generator, Inc.
Type Synchronous
Model No. ABC

4. Is load diverter/~~governor~~ included? Yes/~~No~~.
Yes: Type Diverter Limited,
Model No. 30A
No: Type recommended _____
Model No. _____

5. Additional items supplied with package, e.g. transformer, protection devices, auxiliary equipment. Provide manufacturer, dimensions, operating characteristics

III. EQUIPMENT SPECIFICATION

For a net effective head at the turbine of 175 feet and a flow of _____ cfs, the generator will provide an output of 14.25 kW (assumed power factor of 0.8). This will result in a computed efficiency of 72%. From the information provided, the annual energy production is calculated to be 62,500 kWh.

1. Turbine:

800 rpm at recommended head and flow.
Diameter of runner 18, and type Pelton.

2. Generator:

Operating rpm 1200.
Overspeed allowance 150 %
Voltage 240 ~~single~~/three phase
Rating _____ single/three phase
Power factor _____.

3. Speed increaser

Type Belt
Ratio 1.5:1
Rated input horsepower 25
Service factor 1.5

4. Draft tube, if used: N.A.

Length _____
Elevation from turbine runner centerline to tailwater at lowest water level _____
Outlet area _____
Inlet diameter _____

5. Is unit assembled on equipment frame? Yes/~~No~~

Yes: Dimensions of frame 4 ft x 8 ft

6. Recommended powerhouse minimum dimensions:

Length 16 ft
Width 12 ft
Height 10 ft.

7. Weight of assembled unit 1000 lb
Shipping weight 1200 lb
Wetted weight 1100 lb
Recommended mass of equipment pad 2200 lb.

8. Is shutoff valve or gate provided ahead of turbine? ---/No

No: Recommended size 10 in.
Type Butterfly
Manufacturer Valves, Inc.

9. Recommended spare turbine-generator parts

V-belts _____
Main shaft bearing _____
Brushes _____

10. Expected operating life with normal maintenance and operating conditions: 30 yrs.

11. Turbine warranty provisions included? Yes/~~No~~

12. Is cooling water required for the generator, speed increaser, and/or lubrication system? ~~Yes~~/No

Yes: Flow _____ at _____ temperature, _____ system
Flow _____ at _____ temperature, _____ system
Flow _____ at _____ temperature, _____ system

13. Recommended powerhouse ventilation 150 cfm.

14. With the information provided, the minimum output for the unit would be 14.25 kW at 175 ft head and 1.5 cfs flow. The maximum output for the unit would be 16.5 kW at 175 head and 1.75 cfs flow.

15. Diameter of turbine inlet 10 in. and outlet -- in. or outlet dimensions -- in. by -- in.

16. Lightning protection is/~~is not~~ provided.

IV. COST OF EQUIPMENT RECOMMENDED

(Choose Appropriate Answer(s))

1. The cost estimate is/~~is not~~ based on a complete unit cost.
2. The cost delivered to the site is \$8,500.
Bid ~~is~~/is not attached.
3. On the basis of information provided, the cost of the equipment recommended should approach _____ delivered to the site.
(This is not a bid.)
4. The cost estimates are good until 6/1/83.

V. ADDITIONAL INFORMATION

1. Recommended material and equipment not furnished by company.

Penstock: Size _____ Material _____

Valves _____

Electrical equipment _____

Additional items _____

2. Delivery time for packages 4 months

3. Recommended design considerations _____

4. Additional services provided by Company (i.e., financing, complete design, installations, etc.).

5. Specific Comments _____

6. Please provide a list of three or four developers with addresses who have installed and operated your units.

Max A. Power _____

Rt. #4, High Head, MT

Karl Krone _____

Box 62, Mountain, CO

Walter Wrights _____

River Road, Moose, ME

17. Determine Market Potential (Subsection 8.4 and Section 7)

Since the developer is the market in this example, this step was omitted.

18. Determine Financing Options (Section 7)

After reviewing Section 7.0, the developer decides that if additional money is needed, he will either take out a second mortgage on his property or seek financing through an equipment manufacturer.

19. Make Preliminary Cost Estimate (Subsection 4.3.1)

The developer received the following price information from the manufacturers and suppliers:

- Turbine Supplies Inc., \$8,500
- Pelton Supplies Inc., \$10,000
- Impulse Supplies Inc., \$12,000

The Turbine Supplies Inc. bid is selected because it supplies all the desired features and is least expensive.

Following the guidelines given in Section 4.3, the developer makes the following cost estimate:

- $\$8,500 \times 2 = \$17,000$ (estimated construction and equipment cost)
- $\$17,000 \times 0.1 = \$1,700$ (10% administrative cost)
- $\$18,700 \times 0.25 = \$4,675$ (25% contingency)

$$C_p = \$17,000 + \$1,700 + \$9,675 = \$24,000 \text{ (preliminary cost, rounded up to nearest \$1,000)}$$

$$\frac{\$24,000}{14 \text{ kW}} = \$1,700/\text{kW}$$

NOTE: The developer notes that the cost may be higher because of the long penstock or the lined canal.

20. Go/No-Go (Subsection 4.3.1)

The developer now finds himself at the second go/no-go decision point. The developer determines his present power cost as follows:

Assume that 1 gallon of diesel fuel supplies 13.6 kWh.

$$\frac{22,000 \text{ kWh}}{13.6 \text{ kWh yr}} \text{ gal} = 1,617 \text{ gal/yr}$$

$$1,617 \text{ gal/yr} \times \$1.22/\text{gal} = \$1,972/\text{yr for power}$$

The estimated cost of the system is \$24,000. At \$1,972 per year, it will take 12 years and 2 months for the system to pay for itself. Even though this is a long period, the developer decides to proceed. He has the money available and therefore does not need to borrow. He also feels that the cost of fuel will escalate in the future and his savings will be great in years to come.

21. Select the Design Criteria (Subsection 4.3.2)

The developer decides to buy a complete package system (turbine, generator, and electronic load diverter). The design criteria shown in Table B1-1 are now established.

TABLE B1-1. DESIGN SPECIFICATION

1. Net effective head of 175 feet, or pool-to-pool head range from 185 to 200.
2. The design flow is 1.5 cfs.
3. Turbine:
 - a. Manufacturer Pelton Wheel, Inc.
 - b. Supplier Turbine Supplies, Inc.
3 Gateway Drive
Waterwheel, CA 91919
 - c. Type 18-inch Pelton
 - d. Model No. XYZ
 - e. Shaft speed at design head and flow 800 rpm
 - f. Diameter of turbine inlet 10 inches
 - g. Diameter or dimension of outlet -- inches
 - h. Setting of turbine at throat N.A. feet above minimum tailwater level.
4. Speed increaser type Belt
ratio 1.5:1
input power 25.4 kW [Equation (2-2) with pool-to-pool head and 100% efficiency]
5. Generator:
 - a. Manufacturer Electric Generator, Inc.
 - b. Supplier Same as turbine
 - c. Type Synchronous
 - d. Model No. ABC
 - e. Operating speed 1200
 - f. Voltage 240 phase 3
6. Wetted weight of equipment 1100 pounds
7. Dimensions of equipment frame 4 feet x 8 feet
8. Load diverter/governor:
 - a. Manufacturer Diverter Limited
 - b. Supplier Same as turbine
 - c. Type Electronic
 - d. Model No. 30A

22. Design the System (Subsections 4.4 through 4.9)

Intake System (Subsection 4.4).

The developer still does not have enough information to select the preferred alternative for the penstock routing. Both alternatives (2 and 3) will be designed and costed.

Alternative 2--The penstock intake structure is located near the stream, and a long penstock is used to transmit the water to the existing powerhouse. The design would be as follows:

As shown in Figure 4.4-1, Subsection 4.4.2.1, "Stream Diversion Works," two Gabion weirs can be placed in the stream. The road is closest to the stream about half way between the 185-foot marker and the 200-foot marker. Also at that location, a back hoe can be used to deepen the natural channel. This area is selected as the best location for the diversion works. A level survey reveals that the stream elevation at that location would result in a 194.50-foot pool-to-pool head. The developer also decides to set the height of the berm and reprop at 4 feet above the natural stream bed.

The developer uses Equation (4.4-2) from Subsection 4.4.2.2, "Intake and Power Canal," to determine the cross-sectional area of the intake canal (A_c).

$$A_c = \frac{Q}{2} \quad (4.4-2)$$

where

$$Q = 1.5 \text{ cfs (design flow)}$$

$$A_c = \frac{1.5}{2}$$

$$A_c = 0.75 \text{ ft}^2.$$

The natural stream will be deepened. The developer also decides to deepen the canal to eliminate the potential for freezing. For design purposes, the procedure recommended for determining the canal dimensions is followed. The estimated depth of the unaltered stream bed at low flow is 5 inches, as determined in Event 7. Equation (4.4-3) is used to determine the canal width (W_c).

$$W_c = 12 \times \frac{A_c}{d} \quad (4.4-3)$$

where

$$A_c = 0.75 \text{ ft}^2 \text{ [from Equation (4.4-2)]}$$

$$d = 5 \text{ inches (measured depth, from Event 7).}$$

$$W_c = 12 \times \frac{0.75}{5}$$

$$W_c = 1.80 \text{ ft}$$

Use 2 feet.

The canal demensions are as follows:

$$\text{Width } W_c = 2.0 \text{ ft}$$

$$\text{Depth } d = 5 \text{ in.}$$

$$\text{Area } A_c = 0.75 \text{ ft}^2$$

The developer now sketches a cross section and elevation of the diversion works and power canal on a sheet of graph paper (Figure B1-5). Since the canal is short, it will open directly into the forebay. The developer follows Subsection 4.4.2.4 to determine the forebay dimensions. Equation (4.4-5) is used to find the area of the forebay (A_f).

$$A_f = 8 \times A_c \quad (4.4-5)$$

where

$$A_c = 0.75 \text{ ft}^2 \text{ [From Equation (4.4-2)]}$$

$$A_f = 8 \times 0.75$$

$$A_f = 6 \text{ ft}^2.$$

The width and the depth of the forebay (W_f and d_f) are each equal to the square root of the forebay area.

$$W_f = \sqrt{A_f}$$

$$d_f = \sqrt{A_f}$$

where

$$A_f = 6 \text{ ft}^2 \text{ [from Equation (4.4-5)]}$$

$$W_f = 2.45 \text{ ft}$$

$$d_f = 2.45 \text{ ft.}$$

Use 2.5 feet, or 2 feet 6 inches.

The developer has now followed the recommendations for designing the forebay dimensions.

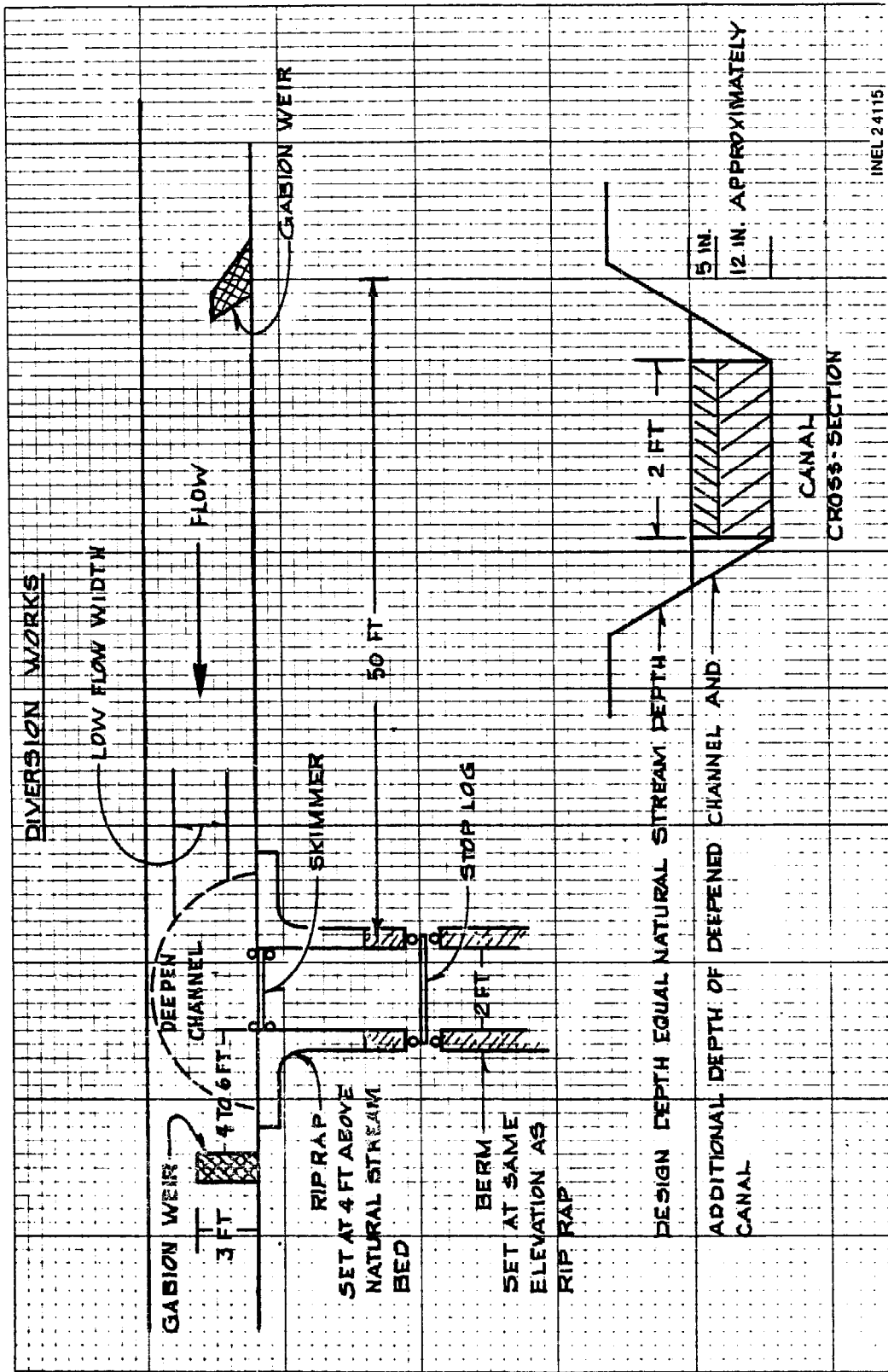

Figure B1-5. Sketch of diversion works.

Because of the severity of the winters in the mountains, the developer decides to deepen the forebay. This will have the added advantage of further reducing the velocity and increasing settling. The developer estimates that the depth of the forebay could easily be increased to between 5 and 7 feet. The decision is made to make the forebay 5 feet deep, which is approximately 3.5 feet deeper than the canal (see Figure B1-5). The developer surveys the area of the diversion works and determines that the forebay can be positioned parallel to the stream and be the recommended 45 feet long.

Next, the developer prepares a sketch of the diversion works and the forebay (Figure B1-6).

The procedures given in Subsection 4.4.2.6, "Penstock Intake," are followed to design the penstock intake structure. As shown in Figure B1-6, the penstock intake was placed at the end of the forebay. This was done because the terrain would not allow the forebay to be placed perpendicular to the stream. The area of the forebay is dictated by the area of the trashrack. The developer reads Subsection 4.4.2.5, "Trashracks," and follows the steps presented for sizing the rack.

o Design Area

Using the recommended velocity of 0.5 fps in Equation (4.4-7):

$$A_{dt} = \frac{Q}{0.5}$$

where

$$Q = 1.5 \text{ cfs (from Event 7)}$$

$$A_{dt} = \frac{1.5}{0.5}$$

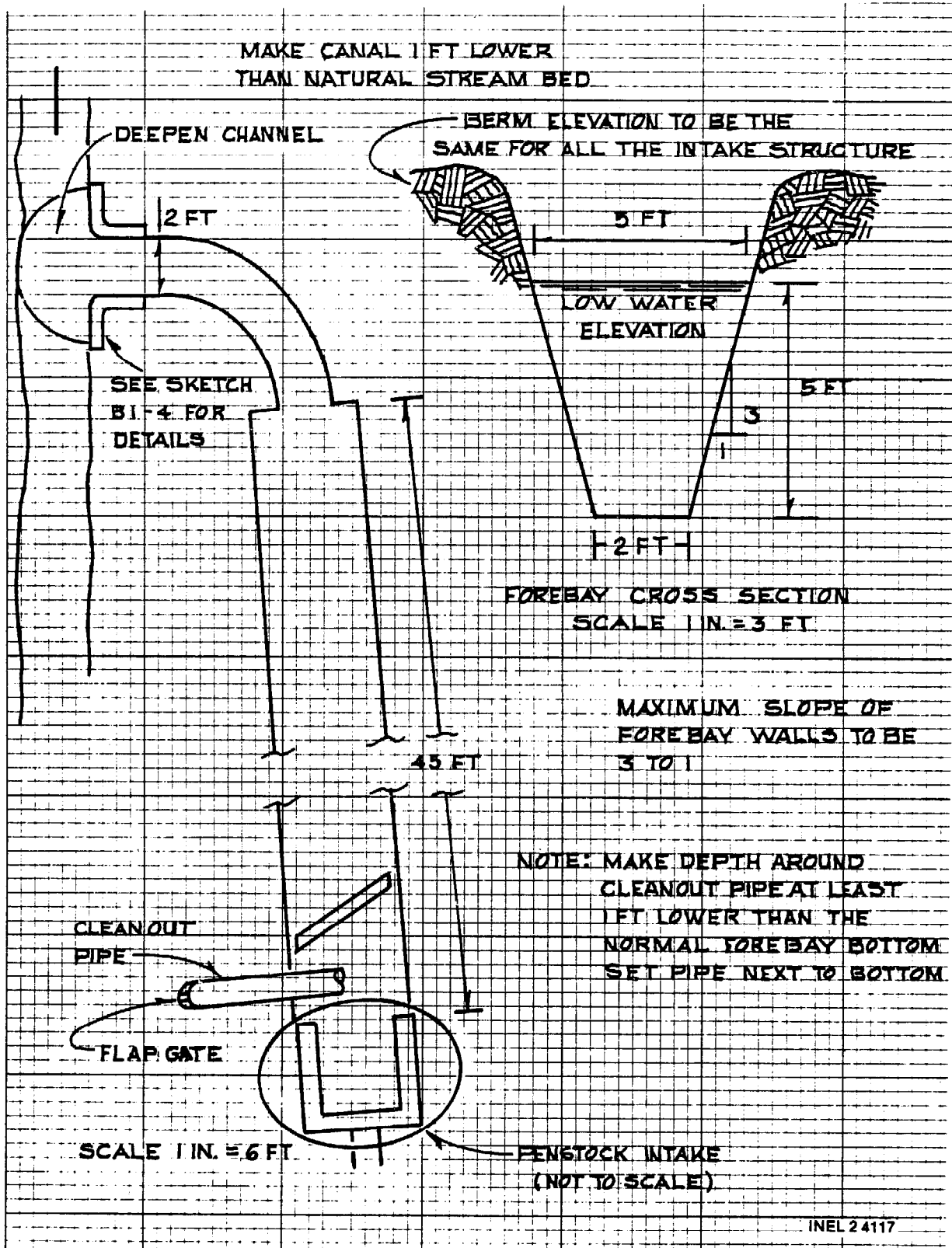

Figure B1-6. Sketch of diversion works and forebay.

$$A_{dt} = 3 \text{ ft}^2.$$

o Length of the Wetted Area

Equation (4.4-8) is used to determine the length of the wetted area.

$$L_w = \frac{d_t}{\sin\theta} \quad (4.4-8)$$

d_t is the depth of water in the intake structure. It is normally equal to the depth of the forebay, which has been set at 5 feet except for around the cleanout pipe (see note in Figure B1-6). In reading Subsection 4.4.2.6, the developer notes that the penstock intake should be above the structure's floor and should be below the freeze line, or at least 1-1/2 pipe diameters below the low-water mark elevation. The following assumptions were made:

- The bottom of the intake is set 6 inches above the floor.
- Maximum ice buildup is assumed to be 2 feet thick.
- For these initial calculations, the penstock diameter is assumed to be at least 1 foot. Therefore, the top of the pipe must be at least 1-1/2 feet below the low-water elevation.

With these assumptions, the minimum structure depth was determined as follows: 2 feet for ice + 1 foot for pipe diameter + 6 inches for height above the floor = 3.5 feet. Since

3.5 is less than 5 feet (depth of forebay), use $d_t = 5$ feet for design depth of water in the intake structure. The developer decides to set the rack at a 60-degree angle; therefore, Equation (4.4-8b) is used to compute the settled length.

$$L_w = \frac{d_t}{0.866} \quad (4.4-8b)$$

where

$$d_t = 5 \text{ ft (from above)}$$

$$L_w = \frac{5}{0.866}$$

$$L_w = 5.77 \text{ ft}$$

- Nominal Width

The nominal width is the clear area of the rack, which is calculated with Equation (4.4-9).

$$W_N = \frac{A_{DT}}{L_w} \quad (4.4-9)$$

where

$$A_{DT} = 3 \text{ ft}^2 \text{ (from Step 1)}$$

$$L_w = 5.77 \text{ ft (from Step 2)}$$

$$W_N = \frac{3}{5.77}$$

$$W_N = 0.52 \text{ ft}$$

- Width of the Trashrack

The nominal width must now be corrected to account for the width of the bars. The developer decides to use 1/4-inch bars spaced 1/2-inch apart. For 1/2-inch clearance between bars, the opening ratio is $r = 1.50$. Using the correction ratio, the width of the rack is computed with Equation (4.4-10).

$$W_T = r \times W_N \quad (4.4-10)$$

where

$$r = 1.50 \text{ (from above)}$$

$$W_N = 0.52 \text{ ft (from Step 3)}$$

$$W_T = 1.50 \times 0.52$$

$$W_T = 0.78 \text{ ft}$$

- Size the Bundles

The wetted area of the rack is equal to L_w (5.77 feet) by W_T (0.78 feet). This says that the width can be anything larger than 0.78 feet and still satisfy the design. Since the bottom of the forebay is 2 feet wide (Figure B1-6), the developer decides to make the penstock intake structure 2 feet wide also. This will help the flow through the trashrack if the top 2 feet freezes.

The developer decides to follow the advice given in Step 5 of Subsection 4.4.2.5 by waiting until the penstock intake structure is constructed and then measuring the actual length that the rack needs to be. The measured dimensions will determine how the rack will be constructed.

The penstock intake structure will be 2 feet wide and will have 5 feet of water at low flow. The height of the intake structure is set by the height of the berm. To clarify that height, the developer sketches the elevation line on a sheet of graph paper (Figure B1-7). The developer starts by drawing a vertical line in the center of the paper. Using a scale of 1 inch = 2 feet, he measures down from the top of the berm to the natural stream bed. From there, he measures 1 foot down from the natural stream bed to the bottom of the canal, and then 3.5 feet down from the canal bottom to the forebay and intake structure bottom. From the sketch, the developer determines that the forebay walls should be 8.5 feet high.

NOTE: This method will only work as long as the berm is maintained at the same elevation.

The developer next sketches the intake structure. Two views are drawn. Figure B1-8 is an elevation drawing showing a cutaway of the side of the structure. Since the drawing is to scale, the trashrack length can be measured as approximately 10 feet. Figure B1-9 is a plan view showing the structure from above. Since the structure is deeper than it is long, the wing walls are placed on the back of the structure, and the berm is filled in around the structure.

The developer now proceeds to estimate the earth work and the amount of concrete involved, using Equation (4.4-14) from Subsection 4.4.4, "Design Layout."

- Earthwork

Canal: 12 feet long, average 3 feet deep, estimated average 3 feet wide.

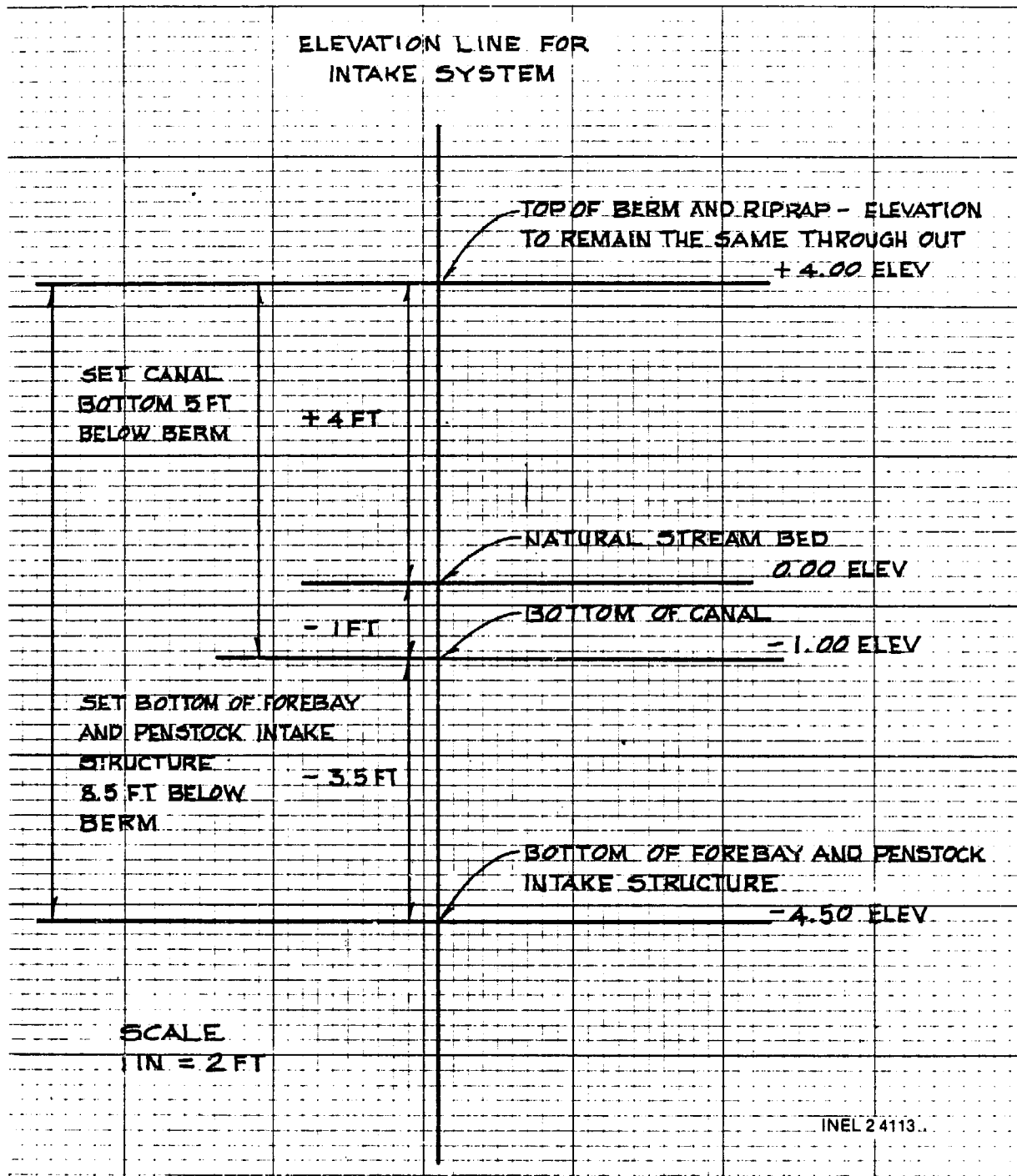

Figure B1-7. Elevation sketch of intake system.

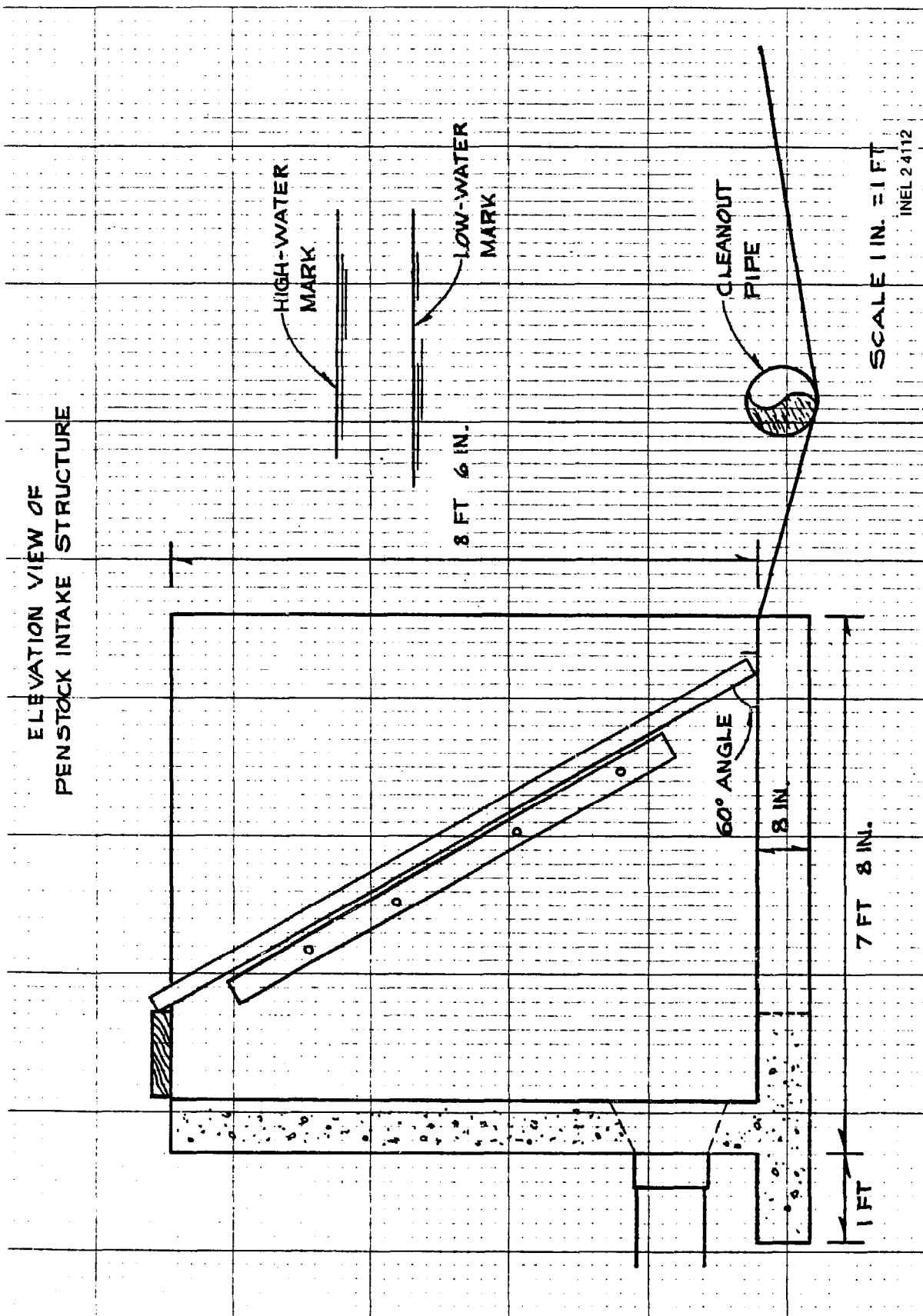

Figure B1-8. Elevation view of penstock intake structure.

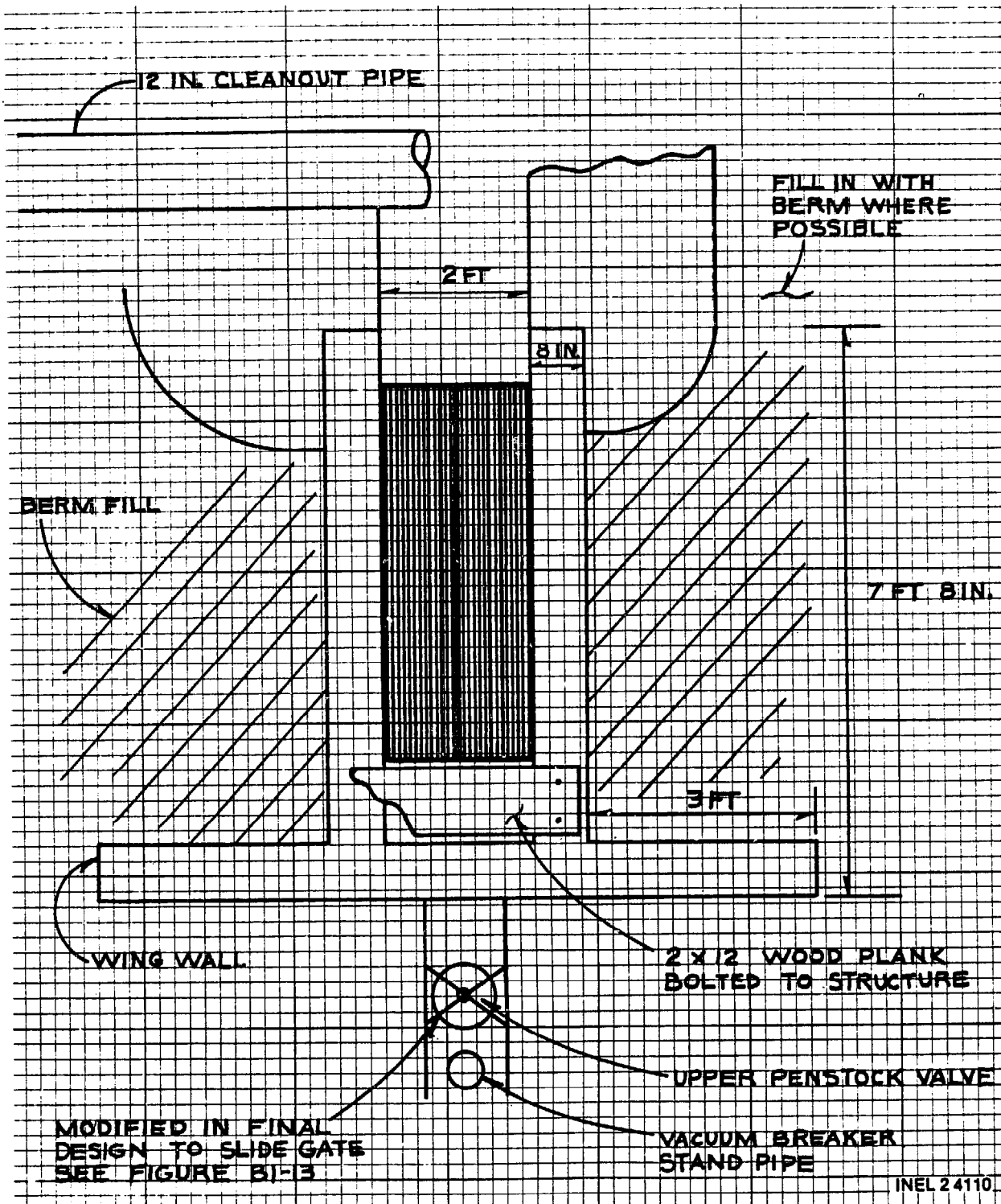

Figure B1-9. Planview of penstock intake structure.

$$V = \frac{L \times W \times d}{27} \quad (4.4-14)$$

$$V = \frac{12 \times 3 \times 3}{27}$$

$$V = 4 \text{ yd}^3$$

Forebay: Length 45 feet, average depth 6.5 feet, average width 5 feet.

$$V = \frac{45 \times 6.5 \times 5}{27}$$

$$V = 54.2 \text{ yd}^3$$

Total earthwork = 58.2 yd³

- Concrete Work

Floor: 8.67 feet long (8 ft 8 in.), 3.33 feet wide (3 ft 4 in.), 0.67 feet deep (8 in.).

$$V = \frac{8.67 \times 3.33 \times 0.67}{27}$$

$$V = 0.72 \text{ yd}^3$$

Wingwall and Backwall: 9.33 feet long (9 ft 4 in.), 0.67 foot wide (8 in.), 8.5 feet deep (8 ft. 6 in.).

$$V = \frac{9.33 \times 0.67 \times 8.5}{27}$$

$$V = 1.97 \text{ yd}^3$$

Sidewalls: Two at 7 feet long, 0.67 foot wide (8 in.), 8.5 feet deep (8 ft 6 in.).

$$V = \frac{2 \times 7 \times 0.67 \times 8.5}{27}$$

$$V = 2.95 \text{ yd}^3$$

Wing Wall Footings: Two at 3 feet long, 2.67 feet wide (2 ft 8 in.), 0.67 foot deep (8 in.).

$$V = \frac{2 \times 3 \times 2.67 \times 0.67}{27}$$

$$V = 0.40 \text{ yd}^3$$

Total Concrete:

$$V = 0.72 + 1.97 + 2.95 + 0.40$$

$$V = 6.04 \text{ yd}^3$$

Round up to 7 yd³.

- Alternative 2 Intake System Cost Estimate

The developer figures that the earthwork can be done in 1 day. An estimate of \$200 is obtained from a farmer with a backhoe.

The concrete work will cost approximately \$75.00 per yard, including form work.

$$7 \times \$75.00 = \$525.00$$

A blacksmith estimates that the rack and supports will cost \$350.00. The skimmer, stoplog, etc., which will be constructed from locally available material, were not costed. Thus, a summary cost estimate for the Alternative 2 Intake System is as follows:

Canal and forebay	\$ 200
Cleanout pipe and valve	\$ 225
Intake structure	
Concrete	\$ 525
Rack	<u>\$ 350</u>
	\$1300

Alternative 3--A power canal is used to carry water to a location above the homesite. The canal must be lined for any distance over 1/4 mile. The design would be as follows:

Design of the diversion works is the same as for Alternative 2, shown in Figure B1-5. Dimensions of the power canal are also the same size as calculated for the canal in Alternative 2.

$$\text{Width } W_c = 2.0 \text{ ft}$$

$$\text{Depth } d = 5 \text{ in.}$$

$$\text{Area } A_c = 0.75 \text{ ft}^2$$

Since the canal is long and must be lined, the developer decides to stay with these basic dimensions. The developer contacts a local contractor and estimates that a concrete-lined canal could cost

approximately \$5.50 per running foot installed. The canal is measured from the diversion works to the penstock intake structure and found to be 3,700 feet long. The length is more than 1/2 mile; therefore, a settling basin should also be designed.

The developer proceeds to design the basin, using Equation (4.4-4).

$$W_s = 4 \times W_c$$

where

$$W_c = 0.75 \text{ ft}^2 \text{ (from above)}$$

$$W_s = 4 \times 0.75$$

$$W_s = 3.0 \text{ ft}^2.$$

The developer decides to make the basin 2 feet deep and 3 feet wide. This will yield an area of 6 ft² (2 x 3), which is more than the recommended minimum of 3.0 ft². There is room at the diversion works to make the basin 90 feet long. The developer decides not to make a sketch unless this alternative is selected.

The design of the forebay and penstock intake structure are the same as for Alternative 2.

The developer proceeds to make a cost estimate, using Equation (4.4-14) from Subsection 4.4-4, "Design Layout."

- Earthwork

Canal: 3,700 - 90 (settling basin) - 45 (forebay)
= 3,565 feet long; 1.5 feet deep; average 2.5 feet wide.

$$V = \frac{L \times W \times d}{27}$$

(4.4-14)

$$V = \frac{3565 \times 1.5 \times 2.5}{27}$$

$$V = 495 \text{ yd}^3$$

Some dozer work will be required to level a part of the hillside before the canal can be dug. A separate estimate is received for this work.

Settling basin: 90 feet long, 2 feet deep, 3 feet wide.

$$V = \frac{90 \times 2 \times 3}{27}$$

$$V = 20 \text{ yd}^3$$

Forebay: Same as Alternative 2.

$$V = 54.2 \text{ yd}^3$$

Total Earthwork:

$$V = 495 + 20 + 54.2$$

$$V = 569.2 \text{ yd}^3$$

Use 570 yd³.

- Concrete Work

Concrete work is the same as Alternative 2 for structure.

$$V = 7 \text{ yd}^3$$

● Alternative 3 Intake System Cost Estimate

Alternative 3 requires more earthwork than the neighbor with the backhoe cares to get involved with. For that reason, a bid is obtained from local contractor for the earthwork, at \$1.25 per in-place cubic yard, or $570 \times 1.25 = \$712.50$.

The penstock intake structure cost is the same as for Alternative 2, $\$525.00 + \$350.00 = \$875.00$.

Two cleanout pipes are needed (settling basin and forebay). The estimated cost is \$450.00.

The canal lining costs \$2.00 per running foot. The requirement is to line any part of the canal longer than 1/4 mile. The developer clarifies that the first 1/4 mile need not be lined.

$3,700 \text{ ft} = 1,320 \text{ ft (first 1/4 mile)} = 2,380 \text{ ft to be lined}$

$2,380 \times \$5.50 = \$13,090.00$ for lining

Thus, a summary cost estimate for the Alternative 3 Intake System is as follows

Earthwork	\$ 712
Dozer work	1,200
Canal lining	13,090
Cleanout pipes	450
Intake structure	<u>875</u>
	\$16,327

Before the final selection between Alternative 2 and 3 can be made, the cost of the penstock must be added in.

Penstock and Valves (Subsection 4.5).

The developer proceeds to size the penstock. The diversion works was previously established at 194.5 feet of pool-to-pool head. At that location, the length of the penstock is measured at 3025 feet for Alternative 2 and 425 feet for Alternative 3.

Alternative 2--The proposed penstock route shown in Figure B1-2 is the best route for Alternative 2. This route requires two bends. The USFS special-use permit requires that the penstock be buried

Figure 4.5-2 from Subsection 4.5 is used to determine the penstock size. The figure, as used, is shown in Figure B1-10. The developer starts by estimating the location of the 1.5-cfs flow on the bottom scale. Since the scale is a log scale, 1.5 is estimated to be a little to the right of center between 1 and 2, and point 1 is marked on the graph. A vertical line is drawn up from Point 1 to Point 2 on the 4-fps line. The line intersects the 10-inch-diameter line at Point 3. At Point 3, the velocity in the pipe is read as 2.8 fps. From Point 3, a horizontal line is drawn to Point 4, and the head loss is read as 0.3 feet per 100 feet of pipe. The developer also notes that if an 8-inch pipe diameter is chosen instead of 10 inches, the velocity would be 4.5 fps and the head loss would be 1.0 feet per 100 feet of pipe (Points 3A and 4A).

Using Subsection 4.5.4.2, "Selecting the Pipe Material," the developer proceeds to determine what material can be used for the pipe.

- Step 1: Determine the static head

Using Equation (4.5-1)

$$S = 0.433 \times h \quad (4.5-1)$$

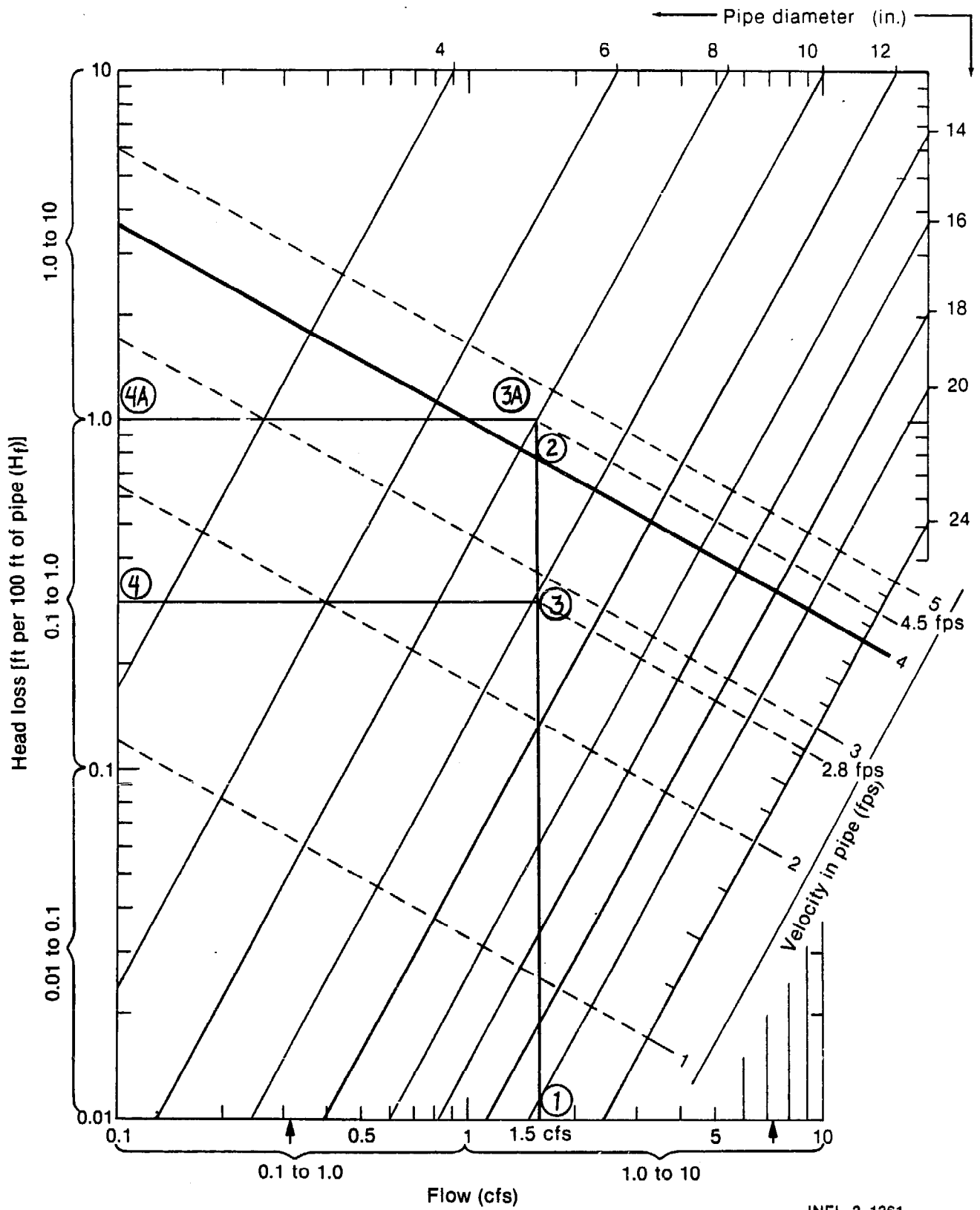

INEL 2 1361

Figure B1-10. Pipe diameter selection graph.

where

$$h = 194\text{-ft pool-to-pool head.}$$

$$S = 0.433 \times 194$$

$$S = 84 \text{ psi}$$

- Step 2: Choose the pipe factors for 8-inch and 10-inch pipe

From Step 1, the P_R must be greater than 84 psi.

For 8-inch pipe:

Steel:	$t_w = 0.25$	$P_R = 800$	$S_A = 54$
PVC:	$t_w = 0.33$	$P_R = 160$	$S_A = 15$
PE:	$t_w = 0.78$	$P_R = 160$	$S_A = 11$
AC:	$t_w = 0.63$	$P_R = 150$	$S_A = 41$
FRP:	$t_w = 0.14$	$P_R = 225$	$S_A = 16$

For 10-inch pipe:

Steel:	$t_w = 0.25$	$P_R = 640$	$S_A = 52$
PVC:	$t_w = 0.41$	$P_R = 160$	$S_A = 15$
PE:	$t_w = 0.98$	$P_R = 160$	$S_A = 11$
AC:	$t_w = 0.83$	$P_R = 150$	$S_A = 42$
FRP:	$t_w = 0.18$	$P_R = 225$	$S_A = 15$

- Step 3: Determine the design pressure for each material

Using Equation 4.5-2:

$$P_d = S + (S_A \times V)$$

where

$$S = 84 \text{ psi (from Step 1)}$$

$$S_A = \text{from the tables in Step 2}$$

$$V = \text{velocity in pipe: } \begin{array}{l} 4.5 \text{ fps for 8-inch pipe} \\ 2.8 \text{ fps for 10-inch pipe.} \end{array}$$

For 8-inch pipe:

$$\text{Steel: } P_d = 84 + (54 \times 4.5)$$

$$P_d = 327 \text{ psi}$$

$$\text{PVC: } P_d = 84 + (15 \times 4.5)$$

$$P_d = 151.5 \text{ psi}$$

$$\text{PE: } P_d = 84 + (11 \times 4.5)$$

$$P_d = 133.5 \text{ psi}$$

$$\text{AC: } P_d = 84 + (41 \times 4.5)$$

$$P_d = 268.5 \text{ psi}$$

$$\text{FRP: } P_d = 84 + (16 \times 4.5)$$

$$P_d = 156 \text{ psi}$$

For 10-inch pipe:

$$\text{Steel: } P_d = 84 + (52 \times 2.8)$$

$$P_d = 229.6 \text{ psi}$$

$$\text{PVC: } P_d = 84 + (15 \times 2.8)$$

$$P_d = 126 \text{ psi}$$

$$\text{PE: } P_d = 84 + (11 \times 2.8)$$

$$P_d = 114.8 \text{ psi}$$

$$\text{AC: } P_d = 84 + (42 \times 2.8)$$

$$P_d = 201.6 \text{ psi}$$

$$\text{FRP: } P_d = 84 + (15 \times 2.8)$$

$$P_d = 126 \text{ psi}$$

- Step 4: P_R must be greater than P_d

For 8-inch pipe:

Steel:	$t_w = 0.25$, $P_R = 800$, $P_d = 327$	OK
PVC:	$t_w = 0.33$, $P_R = 160$, $P_d = 151.7$	OK
PE:	$t_w = 0.78$, $P_R = 160$, $P_d = 133.5$	OK
AC:	$t_w = 0.63$, $P_R = 150$, $P_d = 268.5$	Do not use
FRP:	$t_w = 0.14$, $P_R = 225$, $P_d = 156$	OK

For 10-inch pipe:

Steel:	$t_w = 0.25$, $P_R = 640$, $P_d = 229.6$	OK
PVC:	$t_w = 0.41$, $P_R = 160$, $P_d = 126$	OK
PE:	$t_w = 0.98$, $P_R = 160$, $P_d = 114.8$	OK
AC:	$t_w = 0.83$, $P_R = 150$, $P_d = 201.6$	Do not use
FRP:	$t_w = 0.18$, $P_R = 225$, $P_d = 126$	OK

The developer notes that any material can be used except transite.

Using Subsection 4.5.4.3, "Calculate Penstock System Head Loss," the developer now proceeds to determine how much head loss would be associated with the various pipe materials. The penstock routing for Alternative 2 has two 45-degree bends along the length of the route and a 45-degree bend into the powerhouse. The adjusted length is determined as follows:

- The length of the penstock is 3025 feet.
- For three 45-degree add 45 feet (3 x 15).
- For the penstock intake, add 15 feet.
- For the turbine isolation valve, add 100 feet.

- The adjusted penstock length (L_a) is 3185 feet (3025 + 45 + 15 + 100).

The head losses for 8-inch and 10-inch pipe are computed using Equation (4.5-4).

$$h_1 = \frac{f_c \times L_a \times H_f}{100}$$

where

f_c = friction loss correction factor from Table 4.5-2

L_a = 3,185 feet, from above

H_f = 0.3 foot for 10-inch pipe, from Figure B1-10

H_f = 1.0 foot for 8-inch pipe, from Figure B1-10.

- Head loss for 8-inch pipe:

Steel: $f_c = 1.16$

$$h_1 = \frac{1.16 \times 3,185 \times 1.0}{100}$$

$$h_1 = 37 \text{ ft}$$

PVC: $F_c = 0.77$

$$h_1 = \frac{0.77 \times 3,185 \times 1.0}{100}$$

$$h_1 = 24.5 \text{ ft}$$

PE: $f_c = 0.77$ (same as PVC)

$$h_1 = 24.5 \text{ ft}$$

FRP: $f_c = 0.77$ (same as PVC)

$$h_1 = 24.5 \text{ ft}$$

On the information request form, the manufacturer stated that the net effective head must be at least 175 feet. This means that the pool-to-pool head, 194 feet, less the function losses must be greater than 175 feet. The developer compares the pipe material as follows for total head loss to obtain the net effective head:

Steel: $194 - 37 = 157 \text{ ft}$ (less than 175 ft; do not use)

PVC, PE, and FRP: $194 - 24.5 = 169.5 \text{ ft}$ (less than 175 ft; do not use)

NOTE: This means that an 8-inch pipe will cause too great a head loss for the pool-to-pool head chosen. The developer has the option of using larger pipe or increasing the pool-to-pool head. To obtain a 175-foot net effective head, the pool-to-pool head would have to be increased to greater than 175 feet (net effective head) plus 24.5 feet (head loss), or more than 200 feet. For this example, the 8-inch pipe option was abandoned. In actual practice, one might want to look more closely at the system, compute a new length of pipe needed to give a pool-to-pool head greater than 200 feet, and refigure the head loss.

- Head loss for 10-inch pipe:

Steel: $f_c = 1.16$

$$h_1 = \frac{1.16 \times 3,185 \times 0.3}{100}$$

$$h_1 = 11.1 \text{ ft}$$

PVC, PE, and FRP:

$$f_c = 0.77$$

$$h_1 = \frac{0.77 \times 3,185 \times 0.3}{100}$$

$$h_1 = 7.4 \text{ ft}$$

The developer computes the net effective head (the static head less the head loss):

$$\text{Steel: } 194 - 11.1 = 182.9 \text{ ft (greater than 175 ft; OK)}$$

$$\text{PVC, PE, and FRP: } 194 - 7.4 = 186.6 \text{ ft (greater than 175 ft; OK).}$$

Any one of the four materials can be used. The developer calls a pipe supplier in Spokane, Washington, and determines that PVC is the least expensive. The developer also learns that 10-inch PVC is available with a wall thickness (t_w) of 0.33, a pressure rating (P_R) of 125, and a surge allowance factor (S_A) of 15. The price quoted per foot was \$3.95 for 0.33 wall thickness and \$4.85 for 0.41 wall thickness.

The developer now looks at Step 3, above, to determine what the design pressure (P_d) is for 10-inch PVC. In Step 3, P_d for PVC was calculated to be 126 psi for pipe with a t_w of 0.41, which is 1 psi greater than the pressure rating for the 0.33- t_w pipe. Since the design pressure is based

on static pressure and surge pressure, which depends on how fast the flow in the pipe is stopped, the developer decides to select the thinner pipe and design the turbine isolation valve to close slowly. The average installation cost is estimated by the supplier to be 25 cents per foot.

- Alternative 2 Penstock Cost Estimate

10-inch PVC, $t_w = 0.33$:

3,025 ft x \$3.95	=	\$11,949
3% tax		<u>358</u>
Total material		\$12,307

Installation labor:

3,025 x \$0.25 = \$ 756

Earthwork to bury the penstock:

Assume an average of 18 inches deep and 12 inches wide. The volume of earthwork is found from Equation (4.4-14).

$$V = \frac{L \times W \times d}{27} \quad (4.4-14)$$

where

$$L = 3,025$$

$$W = 12 \text{ in.}, \text{ or } 1.0 \text{ ft}$$

$$d = 18 \text{ in.}, \text{ or } 1.5 \text{ ft.}$$

$$V = \frac{3,025 \times 1.0 \times 1.5}{27}$$

$$V = 168 \text{ yd}^3$$

The cost is $168 \times \$1.25 = \210.00

Thus, a summary cost estimate for the Alternative 2 penstock is as follows:

Material	\$12,307
Labor	756
Earthwork	<u>210</u>
	\$13,273

Alternative 3--The developer decides to recompute the penstock requirements to see if 8-inch PVC pipe might be used for the shorter penstock. Because the canal must also have a slope for the water to run, the developer contacted the Soil Conservation Service (SCS) in the local county. The SCS recommended that the canal have a 12-foot drop from the diversion works to the penstock intake structure. If the diversion works is set at 194 feet of head, the intake structure cannot be higher than 182 feet ($194 - 12$). Since the net effective head must be 175 feet, the total losses in the penstock cannot exceed 7 feet. The procedure for determining pipe material is followed:

Step 1: Static head 182 ft

$$S = 0.433 \times 182$$

$$S = 78.8$$

Step 2: For 8-inch PVC:

$$t_w = 0.33, P_R = 160, S_A = 15$$

Step 3: $P_d = S + (S_A \times V) = 78.8 + (15 \times 4.5)$

$$P_d = 146.3 \text{ psi}$$

Step 4: $P_R = 160$, which is greater than $P_d = 146.3$. Therefore, 8-inch pipe can be used if the head loss is not too great.

Using Subsection 4.5.4.3, "Calculate Penstock System Head Loss," the developer adjusts the length of the penstock as follows:

- The length of the penstock is 425 feet.
- For one 45-degree bend, add 15 feet (1 x 15).
- For the penstock intake, add 15 feet.
- For the turbine isolation valve, add 100 feet.
- The length of the penstock is 425 feet.
- The adjusted penstock length (L_a) is 555 feet (425 + 15 + 15 + 100).

Now the head loss is computed using Equation (4.5-4).

$$h_1 = \frac{f_c \times L_a \times H_f}{100} \quad (4.5-4)$$

where

$$f_c = 0.77, \text{ from Table 4.5-2}$$

$$L_a = 555 \text{ ft, from above}$$

$$H_f = 1.0 \text{ ft, from Figure B1-10.}$$

$$h_1 = \frac{0.77 \times 555 \times 1.0}{100} \quad (4.5-4)$$

$$h_1 = 4.27 \text{ ft}$$

Since h_1 is less than 7 feet, 8-inch pipe can be used for Alternative 3. The net effective head, the static head less the head loss, would be $182 - 4.3 = 177.7$ feet.

• Alternative 3 Penstock Cost Estimate

8-inch PVC, $t_w = 0.33$, quoted at \$3.10 per foot:

$$425 \times \$3.10 = \$1,317.50$$

Installation labor:

$$425 \times \$1.00 = \$425.00$$

The labor estimate is higher because of the steep terrain that must be transversed.

Pipe supports:

The pipe will have to be supported below the rock bluff. The developer decides to use a support similar to that shown in Figure 4.5-13, and he assumes that the concrete requirement is 2 cubic yards at a cost of \$75 per yard

$$2 \times \$75 = \$150$$

Earthwork:

Since the penstock is on the developer's property, it does not have to be buried. To protect it from freezing and ultraviolet degradation, the developer decides to bury the penstock from the intake to a point about halfway to the powerhouse, and to insulate the rest of it.

$$V = \frac{200 \times 1.0 \times 1.5}{27} = 11.1 \text{ yd}^3 \quad (4.4-14)$$

Because of the steep terrain, the earth work was estimated at \$4.00 per cubic yard.

$$11.1 \times \$4.00 = \$44.40$$

Thus, a summary cost estimate for the Alternative 3 penstock is as follows:

Material	\$1,317
Labor	425
Pipe Support	150
Earth Work	<u>44</u>
	\$1,936

Alternative 2 and 3 Comparison--The developer now summarizes the total cost for Alternative 2 and Alternative 3.

Alternative 2

Intake System	\$ 1,300
Penstock	<u>13,273</u>
	\$14,573

Alternative 3

Intake System	\$16,327
Penstock	<u>1,936</u>
	\$18,263

The developer notes that the canal lining is the high-cost item in Alternative 3 and decides to go back to the State to see if the requirement can be lifted. If it can have been removed, Alternative 3 will cost \$5,238, a \$9,486 savings over Alternative 2. The state response does not favor reducing the requirement, however, and the decision is made to proceed with Alternative 2 and to seek profession engineering and legal help to try to get a waiver of the lining requirement.

The developer makes a sketch of the penstock routing, listing the materials to be used (Figure B1-11).

Valves (Subsection 4.5.5)--The developer next proceeds to select the valves. For the penstock intake, a slide gate similar to the one shown in Figure 4.4-11 is chosen. For the turbine isolation valve, the developer selects a handle-operated butterfly valve. He plans to install the valves in a manner similar to that shown in Figure 4.5-8. Since the turbine is equipped with a deflector plate, the isolation valve is not needed to control the turbine speed.

The developer also decides to install a bypass "Y", as discussed in Subsection 4.5.5.4. A 6-inch gate valve is chosen for the purge valve. The layout for the bypass "Y" is similar to that shown in Figure 4.5-9.

Additional Design Considerations (Subsection 4.5.7)--The developer now proceeds to Subsection 4.5.7 to look at "Additional Design Considerations." The USFS special-use permit requires that the pipe be buried. Because of the potential for freezing and the fact that PVC should be protected from ultraviolet degradation, the decision was made to bury the entire length of penstock. PVC pipe uses restrained joints and so thrust blocks are not required.

Powerhouse (Subsection 4.6)

The powerhouse for the hydrogenerator will be an extension to the end of the present diesel generator building. The equipment manufacturer recommended that the building be at least 16 feet long, 12 feet wide, and 10 feet high. The developer decides to use these dimensions and modify the existing building. A preliminary layout sketch is made (Figure B1-12).

The recommended equipment pad mass is 2,220 pounds, and the size of the equipment frame is 4 feet by 8 feet. The developer decides to make the pad 1 foot larger in each dimension, or 5 feet by 9 feet. Next, the

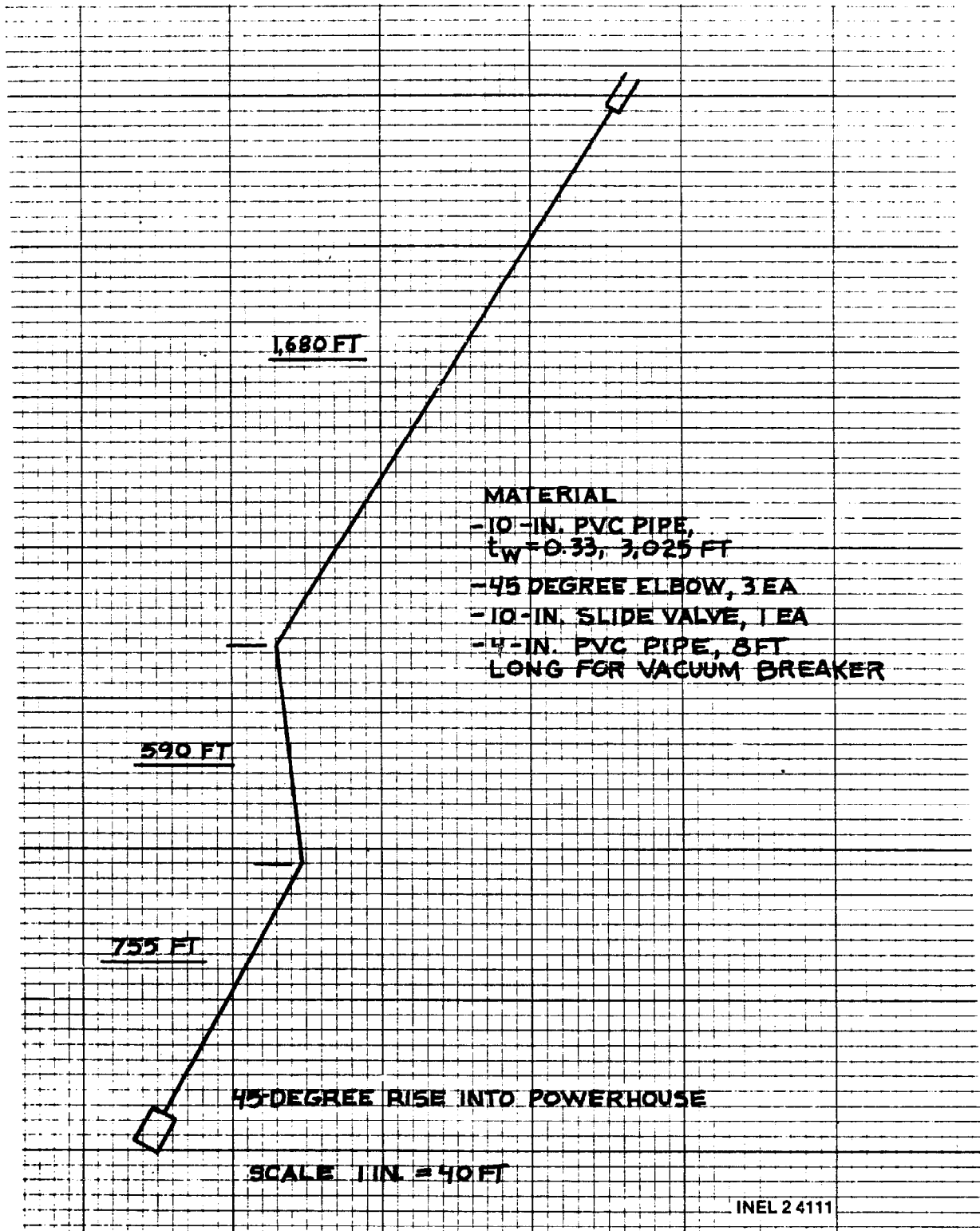

Figure B1-11. Penstock routing.

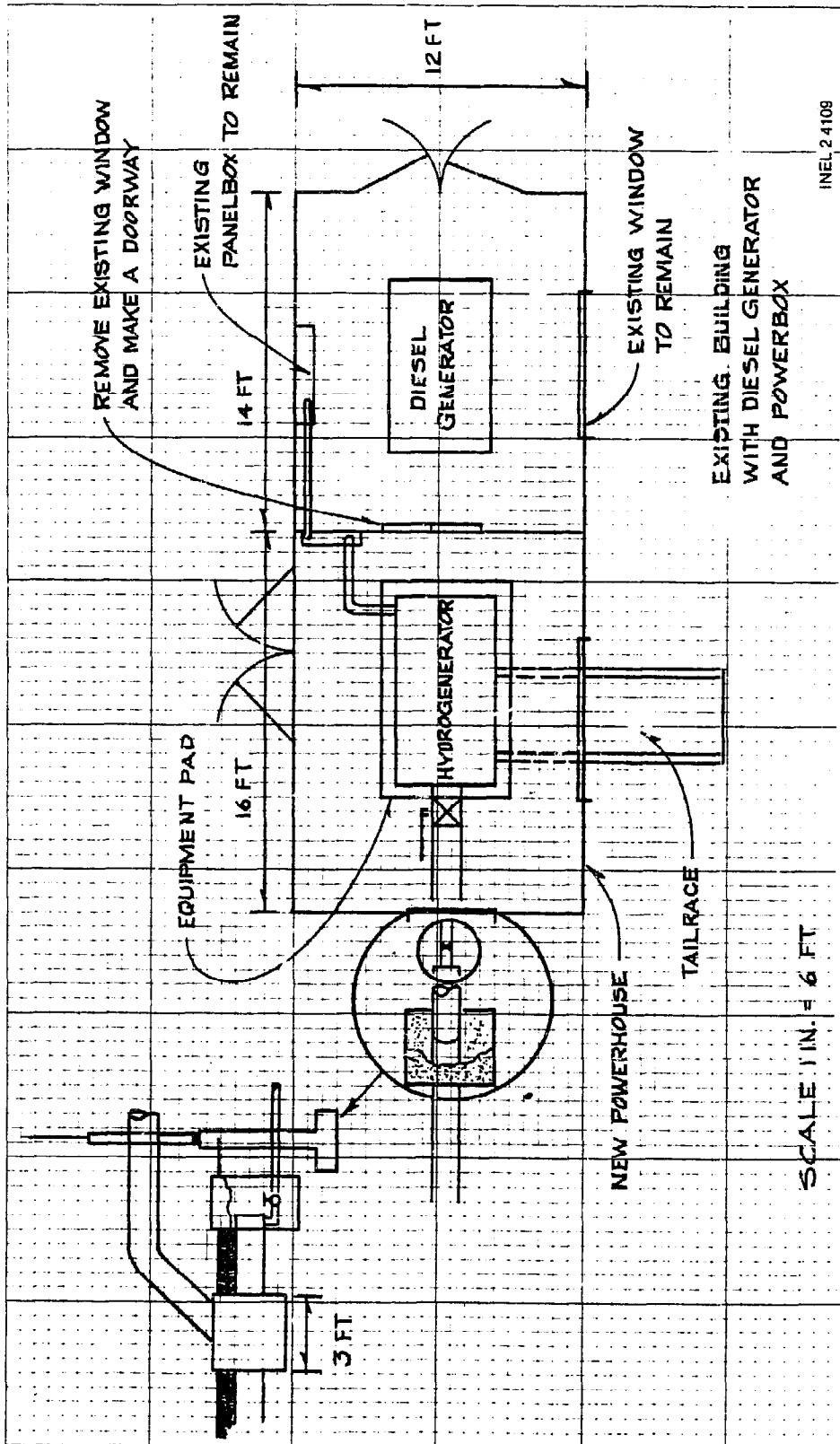

Figure B1-12. Preliminary sketch of powerhouse.

developer finds the mass of the pad for a thickness of 6 inches. As noted in Subsection 4.6.4, "Location and Mounting of the Equipment," concrete weighs approximately 110 pounds per cubic foot. The developer, therefore, finds the volume of the pad as currently planned, and then calculates the mass.

$$5 \times 9 \times 0.5 = 22.5 \text{ ft}^3$$

$$22.5 \times 110 = 2,475 \text{ lb}$$

Since the computed mass is larger than the recommended mass, the pad dimensions are established at 5 feet by 9 feet by 6 inches.

In Subsection 4.6.5, "Powerhouse Cost," the cost was estimated at \$12.00 per square foot.

$$16 \times 12 \times \$12.00 = \$2,300.00$$

Tailrace (Subsection 4.7).

The developer decides to use precast box culvert for the tailrace intake. As shown in Figure B1-12, the tailrace is set perpendicular to the penstock. The size (cross-sectional area) of the tailrace is the same as for the canal. The tailrace is channeled through the property to enhance the esthetics. The developer has to place a culvert pipe under the road. The developer contacts the county and is able to locate a 14-inch used culvert that the county will give to the developer for that purpose.

Thus, a summary cost estimate for the tailrace is as follows

Backhoe	\$100
Box culvert	<u>300</u>
Total cost	\$400

Generator and Electrical (Subsection 4.8).

The developer reads the material in Subsection 4.8 and makes the following decisions.

- The developer decides to get professional help for the electrical work. As part of the service, the developer requests a wiring diagram (Subsection 4.8.1, "Electrical Safety Considerations").
- The developer confirms that he needs a synchronous generator and decides on a self-exciting, self-regulating generator (Subsection 4.8.2, "Generator Selection").
- The developer verifies that the generator should be 240-volt, three-wire, single phase, and that it should be set up to maintain a constant speed and constant power output. The developer also notes that the generator specification should include insulation for at least 105% of rated continuous load and a drip-proof enclosure. (Subsection 4.8.3, "Sizing the Generator and Electrical Distribution System").
- Three meters are required: ac voltage output, ac amperes output, and frequency output (Subsection 4.8.4, "Metering").
- The current is calculated using Equation (4.8-1) (Subsection 4.8.8, "Sizing the Electrical Distribution System").

$$I = \frac{1000 \times P}{E} \quad (4.8-1)$$

where

$$P = 14 \text{ kW}$$

$$E = 240 \text{ V.}$$

$$I = \frac{1000 \times 14}{240}$$

$I = 58.3$ amperes

The rated capacity for the wire, which must be 125% of the current, is computed using Equation (4.8-2).

$$I_m = 1.25 \times I$$

where

$$I = 58.3 \text{ amperes [from Equation (4.8-1)]}$$

$$I_m = 1.25 \times 58.3$$

$$I_m = 73 \text{ amps minimum wire ampacity.}$$

- The developer notes that an overcurrent protection device is required and that it should be located near the generator (Subsection 4.8.9, "Overcurrent Protectors").
- The developer decides to tie the hydrogenerator frame directly to the diesel generator frame. The diesel generator is grounded to a 3/4-inch water pipe that runs from the pumphouse to the powerhouse. The developer decides to weld all of the rebar together and to provide a copper lead from the rebar to the equipment frame. A No. 2 AWG copper ground is placed around both of the powerhouses and connected to both generators (Subsection 4.8.11, "Grounding").
- The developer confirms that he wants to use a load controller (Subsection 4.8.12.2, "Load Controllers"). To ensure that an ample control load source is available, the developer decides to construct the greenhouse which had been planned for years. The greenhouse will be equipped with both passive solar heating and electric resistance heating. The developer takes these requirements to the electrical contractor. The contractor inspects the existing system and then provides a three-line

diagram (Figure B1-13) and a list of major equipment and materials. He also presents the following bid:

	<u>Material</u>	<u>Labor</u>	<u>Total</u>
Generator overcurrent device	\$100	\$ 25	\$ 125
Manual transfer switch	350	50	400
Distribution panel	100	50	150
Greenhouse panel	50	50	100
Conduit	50	100	150
Wire	250	200	450
Trenching	<u>200</u>	<u>-</u>	<u>200</u>
Total			\$1575

The developer reviews the diagrams with the contractor. The contractor explains that the new generator will be connected directly to its overcurrent device and that the two generators will be connected to a manual transfer switch located in the existing powerhouse. From the switch, the generators will be connected to the existing distribution panel also located in the generator building. The frequency sensor and relay control panel will also be connected to the distribution panel. The panel boxes for each residence will be equipped with electronic relays that will control the loads on the basis of priorities established by the load controller. The greenhouse load will be connected to the service by means of a "triac". The triac is explained to the developer as an electronic rheostat that varies the load to the greenhouse heaters.

23. Assemble the Design Package (Subsection 5.1)

The developer reviews Subsection 5.1 and the proposed design. Contacts with professional help regarding the canal lining have not been encouraging; therefore, Alternative 3 is dropped. Sketches made during the design phase are reviewed. The penstock intake structure sketch is modified (Figure B1-14).

B1-70

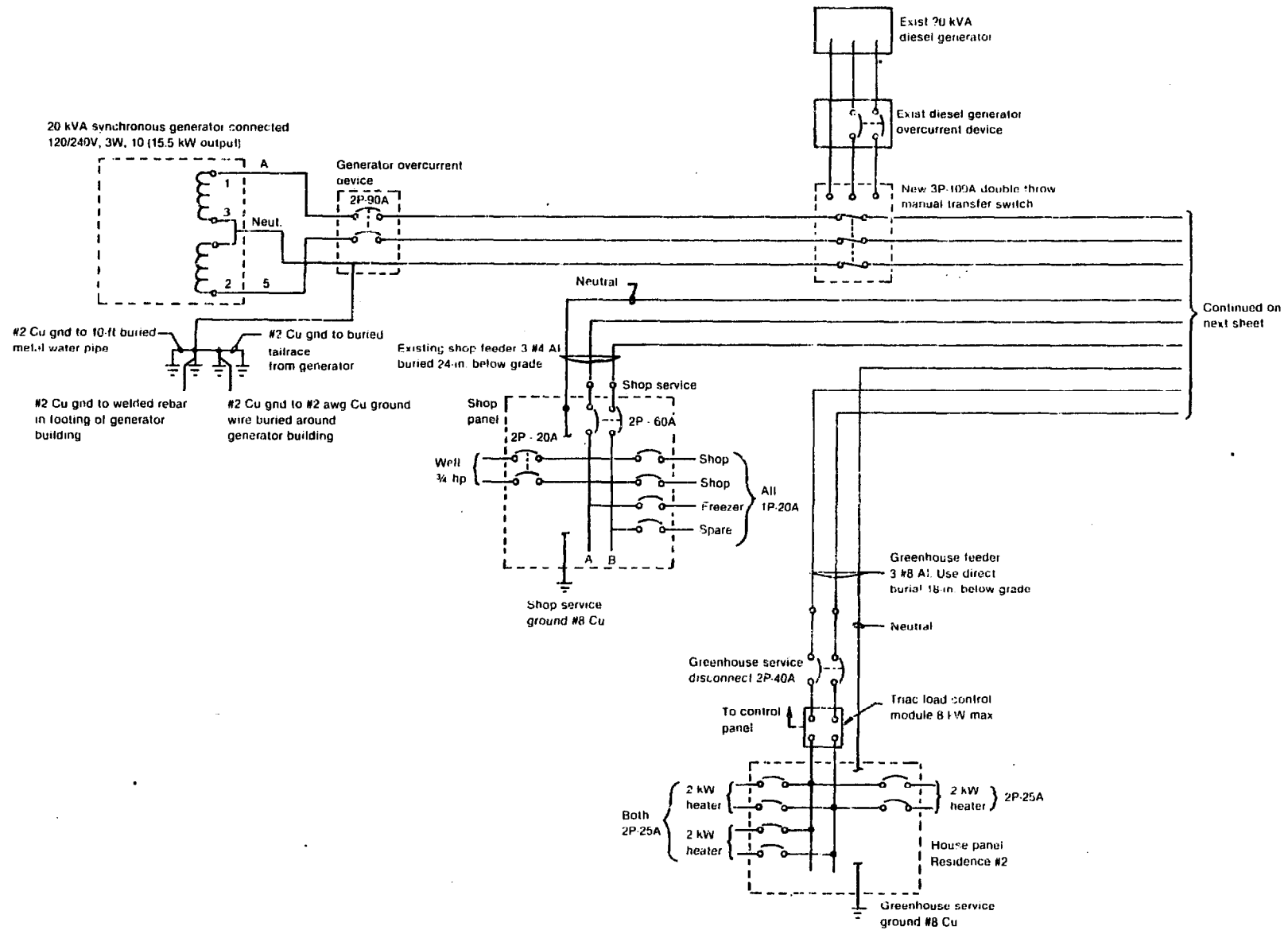

Figure B1-13. Three-line diagram.

INEL 2 2685

B1-71

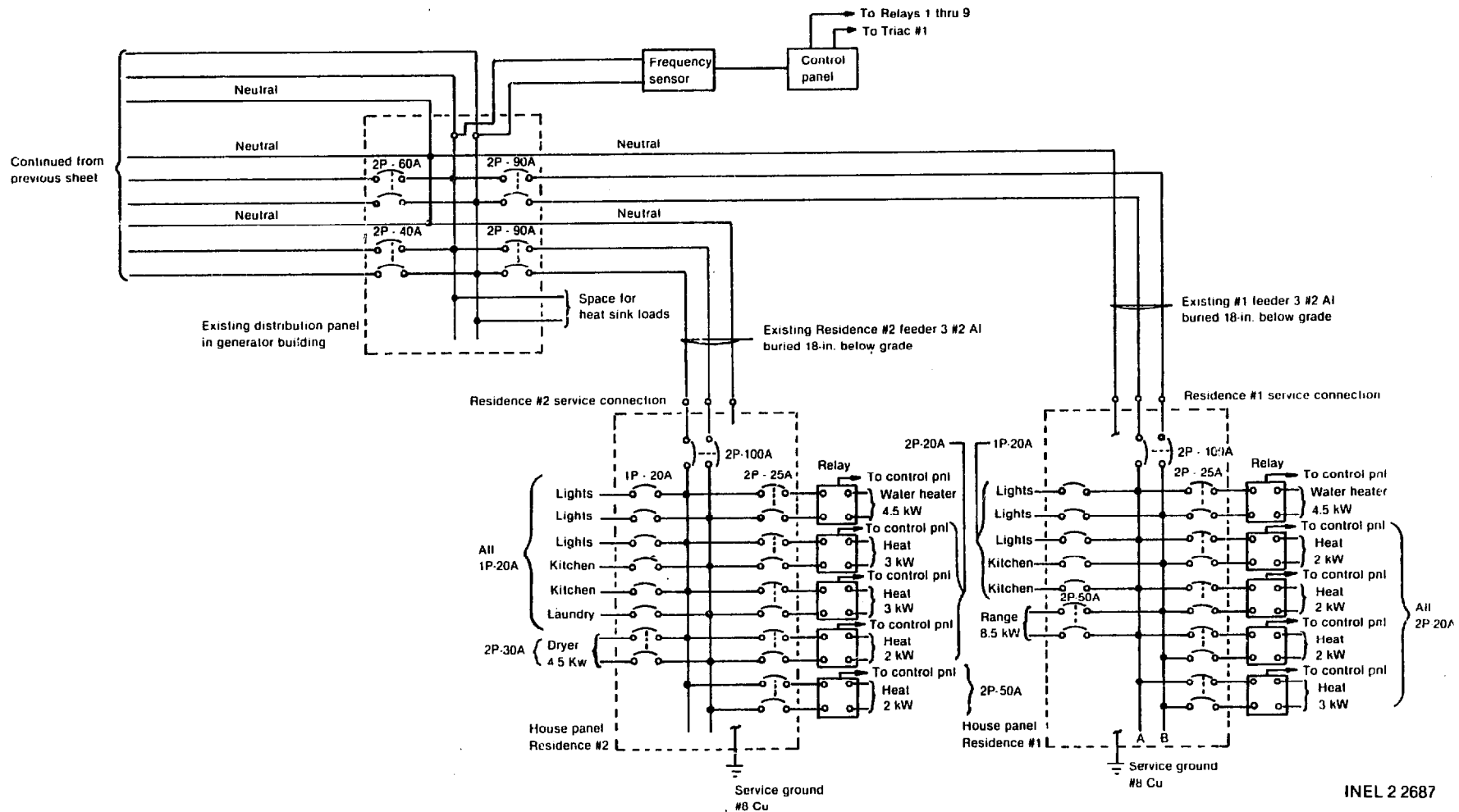

Figure B1-13. (continued)

INEL 2 2687

Turbine Supplies, Inc., is contacted and a formal bid is received, along with specification of the equipment to be provided, which includes:

- 18-inch Pelton Wheel turbine
- 20 kVA synchronous electric generator
- Belt drive speed increaser
- Electronic load diverter
- Overcurrent protection panel with voltage, amperage, and frequency meters
- Equipment frame.

From this information, the developer prepares a material takeoff list:

Intake System

Concrete	7 yd ³
3/4-inch plywood for forms	8 sheets
10-ft 2x4s	24
#4 Rebar	bid quantity
Snap ties, 8-in.	4 dozen
Slide gate	1 ea
Trash rack bundles	3 ea
Cone intake	1 ea

Penstock

10-in. PVC pipe	3,035 ft (10 ft extra)
6-in. gate valve	1 ea
6-in. PVC pipe	20 ft
10-in. blind flange	1 ea

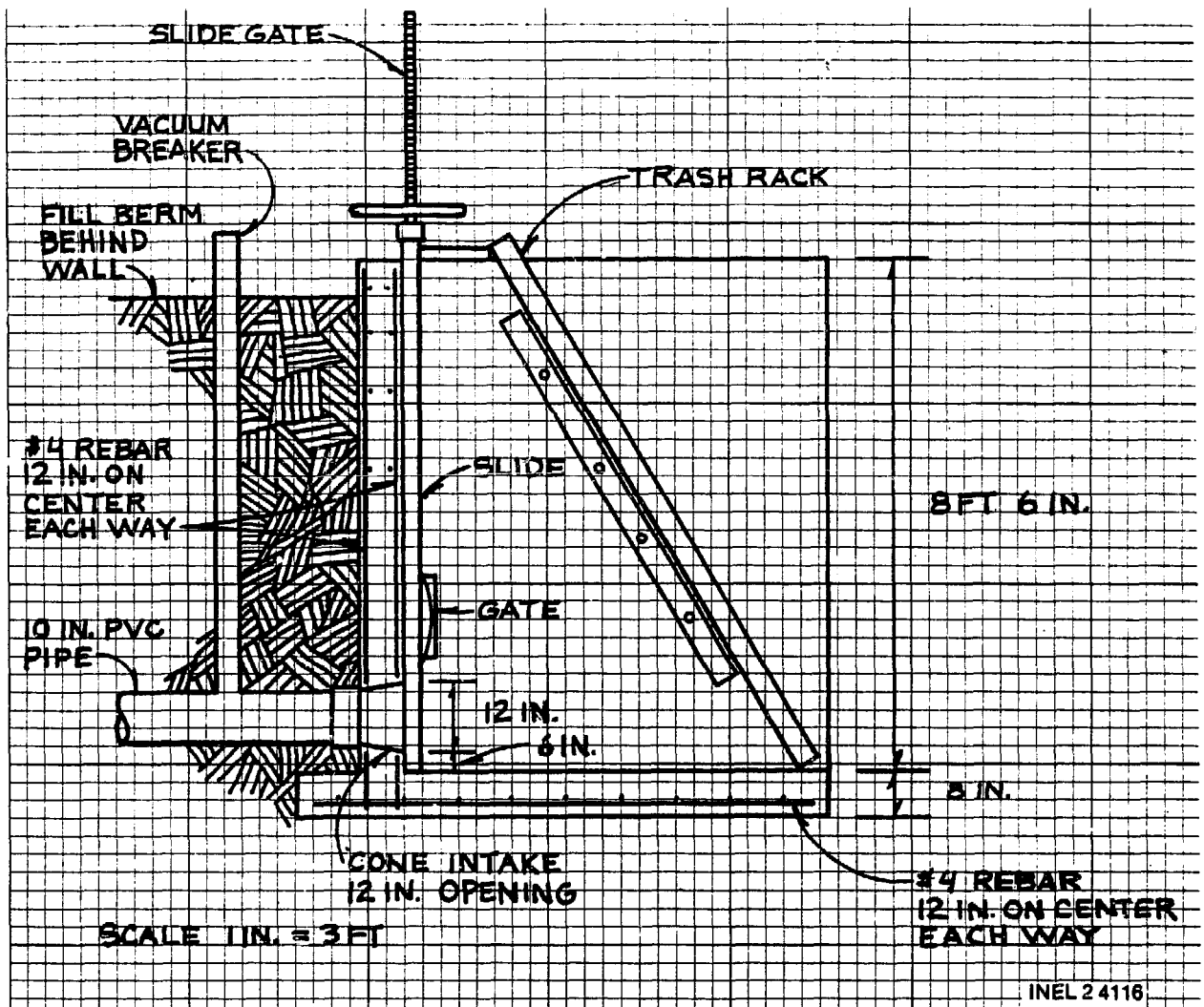

Figure B1-14. Sketch of penstock intake structure (revised).

45-degree elbows, 10-in.	3 ea
45-degree "Y", 10-in.	1 ea
90-degree elbow, 6-in.	1 ea
10-in. butterfly valve	1 ea
Heavy-duty shock absorber	1 ea
Fail-open solenoid pin	1 ea

Powerhouse

Lumber yard will make material takeoff

Tailrace

Box culvert, U-shape, 3 ft x 3 ft 3 ea

Electrical

Bid quantity less overcurrent device supplied by manufacturer.

The developer now prepares a sketch of the powerhouse, Figure B1-15, and develops the following specification to accompany the sketch.

- Wood frame building, 16-ft x 12-ft x 10-ft eave
- 3/4-in. felt board with metal siding
- 5-ft deep foundation with 8-in. pedestal and 2-ft x 6-in. footings, and with #4 Rebar 4 in. on center each way
- Asphalt single roof
- 7-ft double door
- 4-ft x 2-ft and 6-ft x 4-ft sliding windows.
- Roof mounting 6-in. ventallator
- 4-in. bat insulation
- 4-in. concrete floor with 4-in. x 4-in. wire mesh
- 5-ft x 9-ft x 6-in. equipment pad, with #4 rebar 8-in. on center each way.

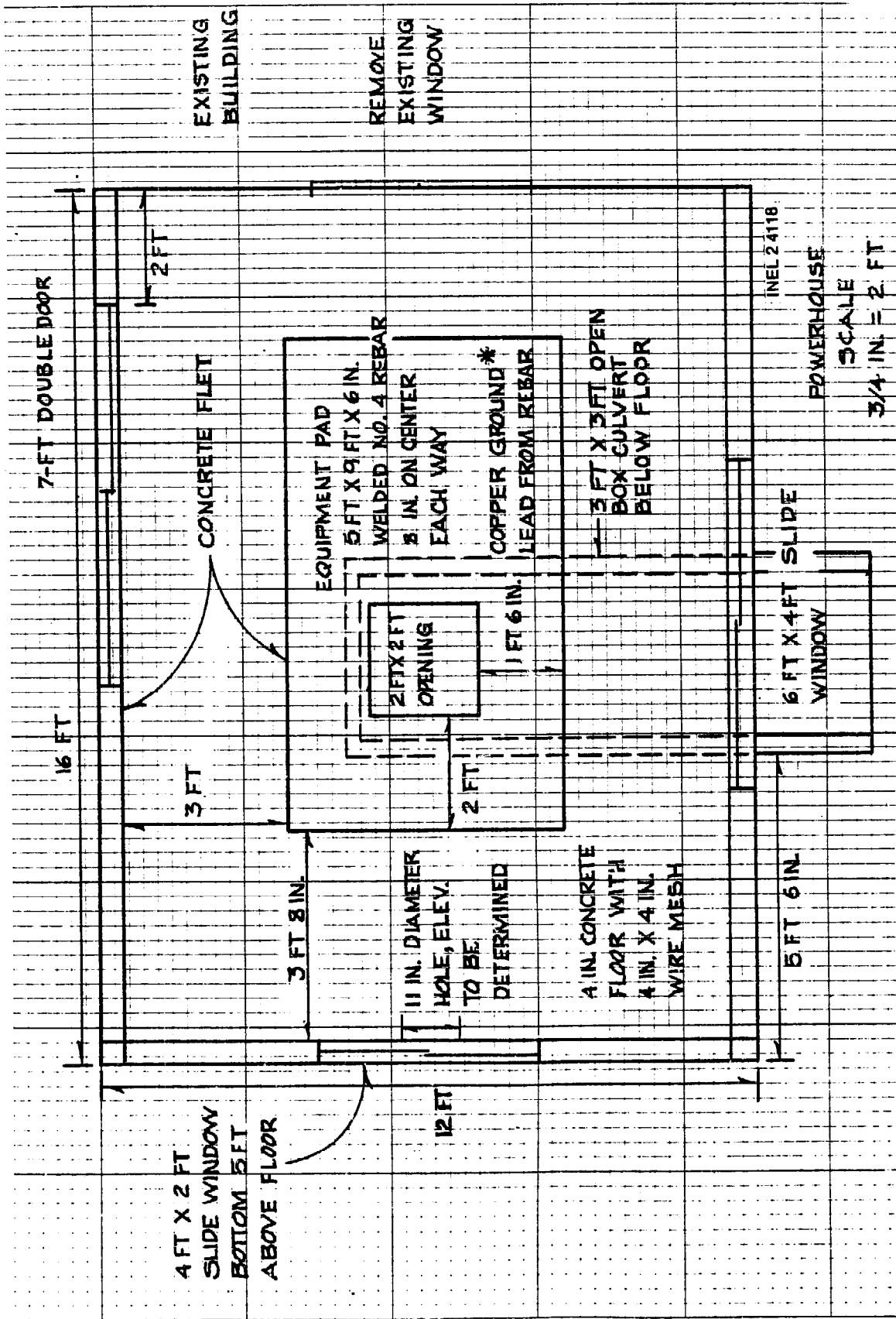

Figure B1-15.. Sketch of powerhouse.

24. Negotiate an Equipment Package (Subsection 5.1.2)

25. Make a Project Cost Estimate (Subsection 5.1.4)

Bids and quotes are received for all materials and recorded on the estimate sheets, as shown in Figure B1-16. The direct cost is determined to be \$28,155.21.

After the indirect and contingency costs are added in, the total estimated cost is \$35,615.21.

26. Go/No-Go (Subsection 5.1.5)

The detailed cost estimate is less than the limit the developer had established for himself. He therefore decides to proceed with the project.

27. Obtain FERC License (Subsection 8.3)

The 120-day review period was elapsed. The developer receives an automatic exemption.

28. Finalize the Marketing Contract (Subsection 8.4)

There are no market contracts in this example.

29. Develop Financial Package (Section 7 and Appendix A-5)

30. Obtain Financing (Section 7)

The developer has the resources to finance \$25,000. The remainder will be obtained through a second mortgage on the property.

Microhydropower

Detailed Cost Estimate

Date 3/10/83
 Page 1 of
 Prep. By W. B. D.

Description	Material Quantity & Units	Mat'l Unit Cost	Unit Labor Hours	Total Labor Hours	Labor Rate	Labor Cost	Material Cost	Other Cost	Total Cost
<i>FIRM BID ITEMS</i>									
TURBINE GENERATOR								8,500	8,500
ELECTRICAL (LESS OVERCURRENT)								1,450	1,450
#4 REBAR PREFABRICATED								125	125
SUBTOTAL BID ITEMS								10,075	10,075
<i>INTAKE STRUCTURE:</i>									
CONCRETE	7 yd ³	53-	-	-	-	-	371		371
3/4 IN PLYWOOD	8 SHEET	4 ⁵⁰	}	REUSE FROM POWERHOUSE					
2x4 x 10's	24 EA	1 ⁵⁰							
8 IN SNAP TIES	4 DT	8 ⁷⁵					35		35
12 IN SLIDE GATE 9 FT ROD	1 EA						75		75
12 IN FLAP GATE	1 EA						63		63
12 IN CORRAGATED PIPE 20 FT	1 EA						220		220
TRASHRACK & SUPPORTS	3 EA	116 ⁶⁷					350	3	350
12 IN PVC REDUCER	1 EA	15 ⁵⁰					15 ⁵⁰		15 ⁵⁰
BACKHOE WORK						200			200
4 FT ROLL CHICKEN WIRE	2 EA	32 ²⁰					64 ⁴⁰	16 ³⁵	80 ⁷⁵

B1-77

Figure B1-16. Cost estimates.

Microhydropower

Detailed Cost Estimate

Date 3/10/83

Page 2 of _____

Prep. By _____

Description	Material Quantity & Units	Mat'l Unit Cost	Unit Labor Hours	Total Labor Hours	Labor Rate	Labor Cost	Material Cost	Other Cost	Total Cost
SUBTOTAL INTAKE STRUCTURE						200	1,193 ⁹⁰	14 ¹⁹	1468 ⁰⁹
PENSTOCK:									
10 IN, P _R = 160, PVC PIPE	3,025 #	3 ⁹⁵	(0.25 PER FT)			756 ²⁵	11,948 ⁷⁵	372 ²²	13,077 ²²
EARTHWORK						210			210
10 IN BUTTERFLY VALVE	1 EA						235		235
6 IN GATE VALVE	1 EA						45		45
6 IN PVC PIPE	20 FT	1 ⁷⁵					35		35
10 IN BLIND FLANGE	1 EA						8 ⁵⁰		8 ⁵⁰
10 IN 45 DEGREE ELBOW	2 EA	11 ²⁵					22 ⁵⁰		22 ⁵⁰
10 IN Y	1 EA						15 ²⁰	3%	15 ²⁰
FAIL OPEN SOLENOID PIN	1 EA						28		28
H.D. SHOCK ABSORBER	1 EA						16 ⁵⁰		16 ⁵⁰
CONCRETE	1 yd ³						53		53
SUBTOTAL PENSTOCK						966 ²⁵	12,407 ⁴⁵	377 ²²	13,745 ⁹²
POWER HOUSE:									
LUMBER YARD TAKEOFF							1,987 ²⁰		1,987 ²⁰
CONCRETE	10 yd ³	53					530		530

B1-78

INEL 2 2697

Figure B1-16. (continued).

Microhydropower

Detailed Cost Estimate

Date _____

Page 3 of _____

Prep. By _____

Description	Material Quantity & Units	Mat'l Unit Cost	Unit Labor Hours	Total Labor Hours	Labor Rate	Labor Cost	Material Cost	Other Cost	Total Cost
SUBTOTAL POWERHOUSE							2,517 ²⁰		2,517 ²⁰
TAIL RACE :									
3 FT X 3 FT BOX CULVERT	3 EA	100					300	9	309
BACK HOE						100			100
SUBTOTAL TAIL RACE						100	300	9	409
SUMMARY OF COST ESTIMATE									
INTAKE STRUCTURE						200	1,193 ⁹⁰	14 ¹⁹	1,408 ⁰⁹
PENSTOCK						966 ²⁵	12,407 ⁴⁵	372 ²²	13,745 ⁹²
POWERHOUSE							2,517 ²⁰		2,517 ²⁰
TAIL RACE						100	300	9	409
BID ITEMS								10,075	10,075
TOTAL DIRECT COST						1,266 ²⁵	16,418 ⁵⁵	10,470 ⁴¹	28,155 ²¹
10% INDIRECT									2,815
									30,970 ²¹
15% CONTINGENCY									4,645
TOTAL ESTIMATED COST									35,615 ²¹

B1-79

Figure 51-10. (continued).

31. Finalize Design (Section 5)

The developer verifies the location of the discharge opening in the equipment pad.

32. Obtain Local Building Permit (Section 8.2)

The developer obtains the county building permit.

33. Construct the System (Subsection 5.2)

The developer follows the recommendations in Subsection 5.2 in constructing his system. At the intake system, the developer constructs the canal, forebays, and penstock intake structure before excavating the final few feet to the stream and deepening the channel. After completing the intake structure, the developer opens the stop logs and floods the structure (penstock slide gate is closed). After letting the water sit for a few hours, the developer props the cleanout flap gate open and lets the intake structure flush out while the remaining portion of the system is constructed.

The penstock and powerhouse are constructed in accordance with standard construction practices. The equipment package arrives, and a forklift is rented in order to remove the package from the truck and set it in the building. Once the package is in the building, come-alongs are used to slide the equipment frame, which has been placed on 6x6 wood timbers. The timbers are used so that the equipment frame will clear the anchor bolts previously set into the floor of the powerhouse in accordance with the manufacturers recommendations. Once the equipment is in position, a framework of 6x6s is constructed, and come-alongs are used to raise the equipment off the timbers and then to lower it onto the pad in position over the anchor bolts.

After the equipment is bolted down, the penstock is connected and the electrician is called in to make the electrical connections. Since the greenhouse has not yet been constructed, the triac and resistance loads are temporarily hooked up in the woodshed. The electrician checks out the electrical portion of the system. For the initial startup, additional resistance loads are connected to the system and the initial startup is performed.

34. Operate the System

After all systems are checked out, the extra resistance loads are disconnected, and the system is restarted in the operating mode.

APPENDIX B-2
MANMADE SITE

Example Description

This site was described in Subsection 2.7. A review of the site description yields the following data:

The developer's site is an existing dam in New Hampshire and includes an old, retired gristmill. The dam produces a 12-1/2-foot drop in the stream elevation. Upstream from the dam, the pool has filled in with gravel and silt, leaving it only 3 feet deep. In a 20-foot wide gorge below the dam, the depth of the stream's normal flow varies from 26 inches in April to 8 inches in late August. Occasional spring rains will raise the stream to 3-1/2 feet.

The developer's residence and 75-head dairy operation are located near the old mill. The residence includes a washer, dryer, refrigerator, freezer, electric stove, hot water heater, and electric heat. The electric utility's distribution line for the valley is within 300 yards of the mill. The developer hopes to supply his electrical needs and sell any excess power to the utility.

Events

1. Lightly Review the Handbook

The developer reviews the handbook as recommended.

2. Read Sections 1 and 2 and Subsection 8.1

The developer reads Section 1 of the handbook and determines that he is a Category 2 developer. He reviews Section 2 to obtain a background in hydropower and finds that his design will be based on manmade hydropower sources. Reading Section 8.1, he obtains a description of some of the environmental considerations he will need to address.

3. Determine Power Requirements

The next step is for the developer to determine the power requirements of his household and dairy. He develops the attached chart (Figure B2-1) using the data in Subsection 3.1.1. From this chart he estimates his peak demand to be about 21 kW.

4. Make Site Inspection

The developer now performs a site inspection, using the items in Subsection 3.2.1 as a guideline. He notes the following items during this inspection:

- The old mill powerhouse and dam are part of the same structure. Although the mill was partially destroyed by fire, it still appears to be the best selection for a powerhouse.
- An inspection of the dam shows spalling on about 20 square feet of spillway surface and some erosion at the toe of the dam that will need riprap.
- From past history, the developer knows that the spillway is adequate to handle the flow. All flooding has been below the dam in the past where twice in the last 15 years the stream has flooded above the 5-foot-deep gorge by only 8 inches. During spring runoff, a moderate amount of debris is carried in the water.
- An inspection of the pool behind the dam shows it to be filled with gravel and silt. The present depth of the pool is only 3 feet. The elevation always remains fairly constant, with the dam acting as a spillway.
- The existing stop log at the powerhouse intake is silted in for 3 1/2 feet.

- The powerhouse still contains an old open flume Francis turbine manufactured by James Leffel Co., but the generator is missing. The governor is still in place but may need work.
- Access to the sight is easily available for construction vehicles over an existing road for farm equipment that goes past the sight. There are no restraining load limits that would prevent heavy vehicles from using it.
- The local utility's power lines pass within 300 yards of the sight.

With the above information, the developer makes a sketch of his sight (Figure B2-2). Since the head and structure elevations are easily obtained during his inspection he adds these to his sketch.

5. Make Initial Contact With State and Local Agencies

The developer now makes initial contact with the state and local agencies. He reads Section 8.2 to determine which agencies may affect development of the site. He contacts the following:

- The New Hampshire Water Resource Board (Appendix E-1)
- The New Hampshire Public Utilities Commission (Appendix E-2)
- The New Hampshire Water Supply and Pollution Control Commission (Appendix E-4)
- The New Hampshire Department of Fish and Game (Appendix E-5)
- The New Hampshire Department of Resources and Economics (Appendix E-7)
- The County Planning and Zoning Commission.

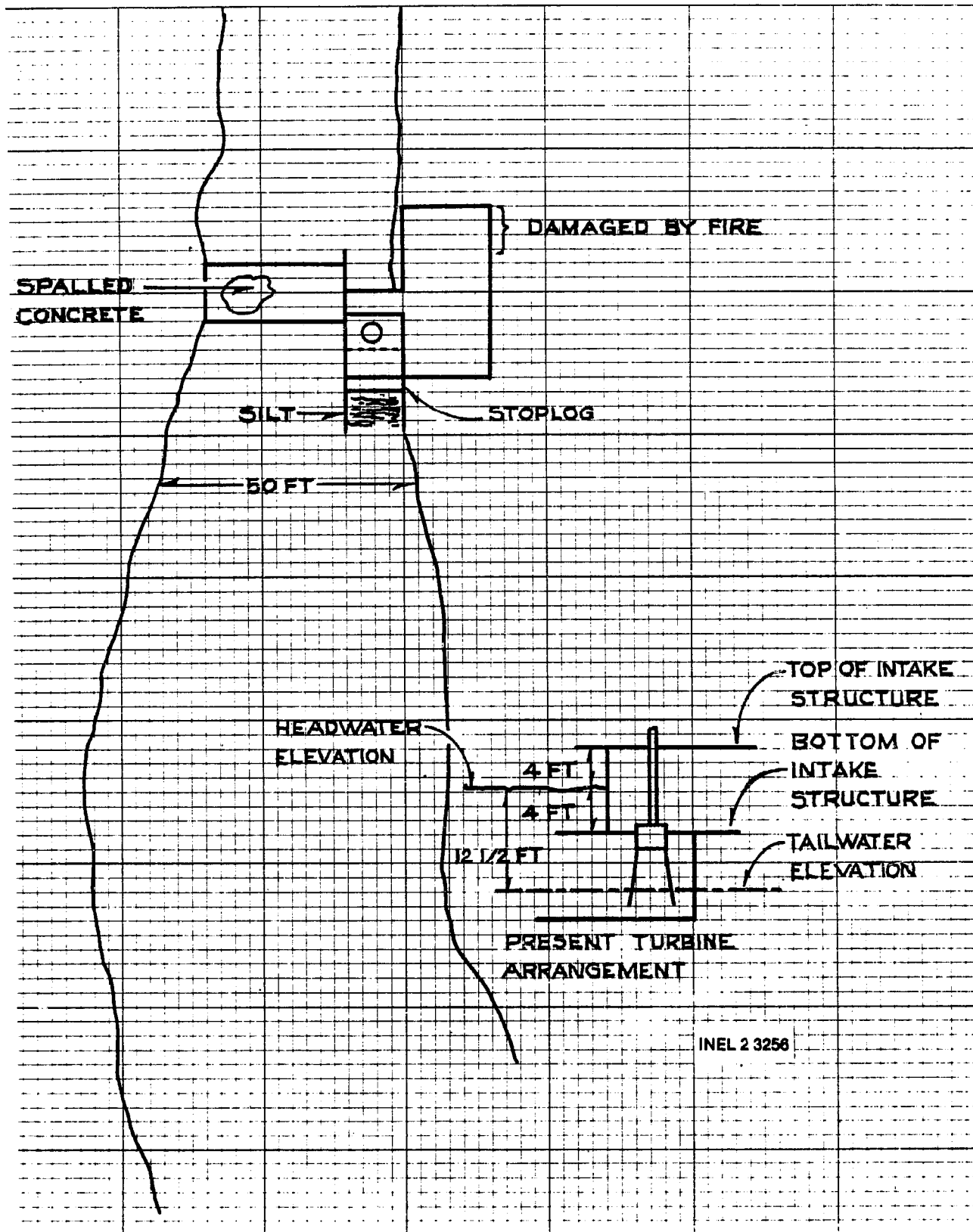

Figure B2-2. Sketch of site.

6. Make Initial Contact for Federal Land-Use Permit

No Federal land is involved and so no Federal land-use permits are required.

7. Determine Available Flow

The developer must now determine his stream's available flow. He reads Subsection 3.3. Since he wishes to produce the most energy available from the stream, a flow duration curve must be developed in order for him to estimate flows in the 20 to 35% exceedance range.

He knows that a stream flow gage exists downstream from his site. He writes a letter to the Northeastern Region office of the USGS at the following address:

USGS
National Center, Mail Stop #433
12201 Sunrise Valley Dr.
Reston, VA 22092

and informs the USGS that the gage station he is interested in is on the Merrimack River near Goffs Falls. It is below the town of Manchester and approximately 15 miles below where the stream his site is on enters the river.

The USGS sends a copy of the NAWDEX for the area he describes (see Table 3-2 in Section 3.3.2). After studying the copy and talking to the local USGS office, he determines that the gage station number of interest is 01092000. He sends another request to the USGS at Reston, Virginia, and receives the flow duration table for the gage under consideration. This table is shown as Table B2-1.

Several other streams flow into the river between where his site's stream enters the river and the gage. He will have to correlate the flow in his stream to the gage station flow duration table. He decides to use a

TABLE B2-1. STATION NUMBER 01092000--DURATION TABLE OF DAILY VALUES FOR YEAR ENDING SEPTEMBER 30

DISCHARGE-(CFS)
 MEAN
 MERRIMACK R NR GOFFS FALLS, BELOW MANCHESTER, NH

Class	0	1	2	3	4	5	6	7	8	9	10	11	12	13	14	15	16	17	18	19	20	21	22	23	24	25	26	27	28	29	30	31	32	33	34
Year																																			
	NUMBER OF DAYS IN CLASS																																		
1978									1	4	4	16	31	22	11	3	7	8	14	27	51	34	43	17	37	12	18	5							
1979											3	8	32	53	64	28	18	20	19	21	11	10	3	15	17	9	19	8	5		2				
1980										6	25	19	26	24	37	24	14	29	39	28	20	19	24	14	10	1	4	1	2						
1981												3	7	13	55	38	36	35	39	29	31	29	14	9	11	4	3	4	3	2					

CLASS	VALUE	TOTAL	ACCUM	PERCT	CLASS	VALUE	TOTAL	ACCUM	PERCT	CLASS	VALUE	TOTAL	ACCUM	PERCT
0	0.0	0	16071	100.0	12	950.0	800	15254	94.9	24	11000.0	740	1927	11.9
1	98.0	2	16071	100.0	13	1200.0	859	14454	89.9	25	14000.0	442	1187	7.3
2	120.0	2	16069	100.0	14	1400.0	1603	13595	84.6	26	17000.0	360	745	4.6
3	150.0	1	16067	100.0	15	1800.0	1334	11992	74.6	27	21000.0	218	385	2.3
4	180.0	3	16066	100.0	16	2200.0	1308	10658	66.3	28	26000.0	109	167	1.0
5	220.0	15	16063	100.0	17	2700.0	1362	9350	58.2	29	32000.0	43	58	.3
6	280.0	40	16048	99.9	18	3300.0	1334	7988	49.7	30	39000.0	11	15	
7	340.0	57	16008	99.6	19	4000.0	1313	6654	41.4	31	48000.0	2	4	
8	420.0	59	15951	99.3	20	5000.0	1074	5341	33.2	32	59000.0		2	
9	510.0	87	15892	98.9	21	6100.0	927	4267	26.6	33	73000.0		2	
10	630.0	173	15805	98.3	22	7500.0	813	3340	20.8	34	89000.0	2	2	
11	770.0	378	15632	97.3	23	9200.0	600	2527	15.7					

VALUE EXCEEDED 'P' PERCENT OF TIME

V95	=	940.0
V90	=	1200.0
V75	=	1800.0
V70	=	2000.0
V50	=	3300.0
V25	=	6500.0
V10	=	12000.0

weir method of flow measurement at a narrow stream location below his site. He sets up a weir with a 6-1/2-foot opening at this location as outlined in Section 3.3.3.1.2. Over the next 2 months, he takes several flow measurements and records them on Table B2-2. These measurements are converted to stream flow using Table 3-4 in Subsection 3.3.3.1.2 and then entered on Table B2-2. For instance, on August 1 the weir depth reading was 10 5/8 inches.

The conversion factor from Table 3-4 is 0.2320, and therefore

$$6 \frac{1}{2} \text{ ft} \times 12 \text{ in./ft} \times 0.232 = 18.1 \text{ cfs}$$

From the NAWDEX previously received, the developer notes that the gage is owned by the USGS. Once again, he writes to the USGS in Reston, Virginia, requesting the daily gage flow readings for the days on which flow measurements were made. These flows are also entered in Table B2-2, and a correlation factor is calculated for each day as described in Subsection 3.3.3.2. For example, the correlation factor for August 4, is as follows:

$$C = \frac{Q_1}{Q_2} = \frac{18.7}{1100} = 0.017$$

From the last column in Table B2-2, the variation in the correlation factor is seen to be small, and so the correlation of gage flow to stream flow can be considered accurate.

The developer now plots a flow duration curve for the gage and his site as discussed in Subsection 3.3.3.3. From Table B2-1, the exceedance values are found for the gage and plotted on Figure B2-3. The site exceedance values are calculated using the lowest correlation factor and the gage exceedance values from Table B2-1. The lowest correlation from Table B2-2 is 0.017. Using this number, the developer makes the following flow duration table:

TABLE B2-2. FLOW MEASUREMENT TABLE

Date	Time	Reading (Depth)	Conversion factor	Computed flow, Q ₁ (cfs)	Gage flow Q ₂ (cfs)	Correlation $\frac{Q_1}{Q_2}$
8/1	10:00 AM	10 $\frac{5}{8}$	0.2320	18.1	1000	0.018
8/4	10:30 AM	10 $\frac{7}{8}$	0.2403	18.2	1100	0.017
8/7	10:15 AM	11	0.2444	19.1	1000	0.019
8/12	11:00 AM	9 $\frac{3}{4}$	0.2040	15.9	940	0.017
8/15	10:20 AM	11 $\frac{7}{8}$	0.2742	21.4	1200	0.018
8/17	10:20 AM	15 $\frac{1}{2}$	0.4089	31.9	1600	0.020
8/20	2:30 AM	14 $\frac{7}{8}$	0.3844	30	1770	0.017
8/24	3:00 AM	15 $\frac{3}{8}$	0.4639	31.5	1651	0.019
8/30	3:20 AM	15 $\frac{1}{8}$	0.3941	30.7	1700	0.018
9/3	2:00 AM	15 $\frac{3}{8}$	0.4138	32.3	1604	0.020
9/8	10:00 AM	13 $\frac{3}{8}$	0.3277	25.6	1513	0.017
9/10	10:30 AM	14 $\frac{3}{4}$	0.3795	29.6	1558	0.019
9/13	2:00 PM	12 $\frac{7}{8}$	0.3095	24.1	1424	0.017
9/17	2:30 PM	13 $\frac{1}{4}$	0.3231	25.2	1400	0.018
9/21	3:00 PM	14 $\frac{3}{4}$	0.3795	29.6	1550	0.019
9/24	10:00 AM	12 $\frac{3}{4}$	0.3050	23.8	1200	0.020

B2-9

<u>Exceedance Value</u>		<u>Gage Flow</u>		<u>Correlation Factor</u>		<u>Site Flow</u>
V95	=	940	x	0.017	=	16
V90	=	1200	x	0.017	=	20.4
V75	=	1800	x	0.017	=	30.6
V70	=	2000	x	0.017	=	34
V50	=	3300	x	0.017	=	56.1
V25	=	6500	x	0.017	=	110.5
V10	=	12000	x	0.017	=	204

The site flow is plotted on the left vertical axis of Figure B2-3. This provides the developer with a flow duration curve for his site.

8. Measure Head and Distance

The developer now must accurately measure his pool-to-pool head. He determines that the level survey method discussed in Subsection 3.4.1.2 will provide an adequate measurement. This method confirms that his initial inspection measurements of the head are accurate at 12 1/2 feet.

9. Determine Design Capacity

The plant capacity can now be calculated using the information determined in previous steps and Section 3.6. Since the head is relatively constant over the year, with only a 18-inch rise in the tailwater in the spring, he decides to use Subsection 3.6.1 to calculate the design capacity. Following the procedure recommended in Subsection 3.3.1, the developer uses a flow of 110.5 cfs at 25% exceedance to calculate his power. Using Equation (2-2), he determines his power to be:

$$P_d = \frac{Q \times h \times e}{11.81}$$

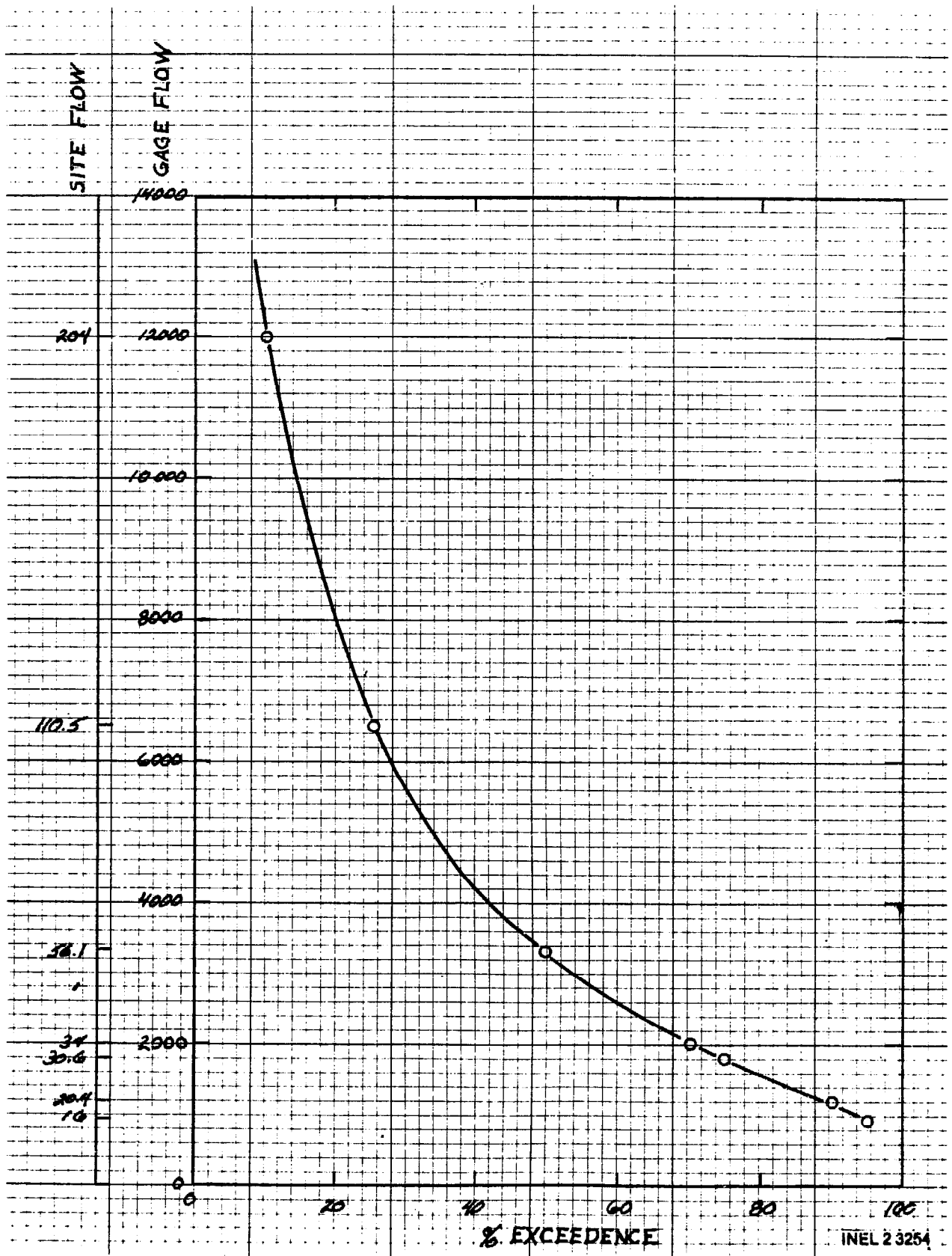

Figure B2-3. Flow duration curve.

$$P_d = \frac{110.5 \times 12.5 \times 0.6}{11.81} = 70.2 \text{ kW}$$

9a. Determine Annual Energy Production

From Section 3.7, the developer estimates his annual energy production. Using a 50% plant factor and Equation (3-15), he calculates:

$$70.2 \text{ kW} \times \frac{24 \text{ hrs}}{\text{day}} \times \frac{365 \text{ days}}{\text{year}} \times 0.5 = 306700 \text{ kWh}$$

Initial responses from the agencies contacted are received at about this time and can be used in the initial Go/No-Go decision of Step 10. The New Hampshire Water Resource Board tells the developer that a water right permit, a dam safety permit, and a water quality permit must be obtained. The Water Resource Board also informs the developer that the old mill is a historic land mark and that he must contact the Department of Resources and Economics.

The New Hampshire Department of Resources and Economics requires that the old mill structure be renovated to appear as a mid 19th century grist mill as part of the development project.

The New Hampshire Department of Fish and Game tells the developer that a fish ladder will not be required at present since the dams downstream from the site are not equipped with fish ladders.

The New Hampshire Water Supply and Pollution Control Commission requires that any dredging be done at low flow so that any sediment disturbed by the dredging will not be transported downstream. The developer is also informed that a COE permit will not be necessary.

The local Planning and Zoning Commission tells the developer that the site is already zoned for this type of development and all he will need is a county building permit before construction starts.

10. Go/No-Go

The developer is at his first Go/No-Go decision. He has determined that his site can produce more power than he uses--70 verses 21 kW. The initial responses from the state and local agencies have not raised any problems which cannot be overcome. On this basis, he decides to continue with the development of the site.

11. Determine Federal Requirements

The developer reviews Subsection 8.3 and determines that he should file for a notice of exemption for existing dams. The developer contacts the regional FERC office and discusses his opinion of filing for an exemption. The regional FERC office agrees with his findings.

12. Obtain State and Local Permits

The developer applies for a water right permit, a dam safety permit, and a water quality permit.

The state issues the water right permit and the water quality permit. The state requires an inspection of the dam before issuing a safety permit. After the inspection, the developer is informed that the concrete on the spillway must be repaired and riprap placed at the toe of the dam to prevent further erosion of the stream bed before a safety permit can be issued.

13. Obtain Federal Land-Use Permit

No Federal land-use permits are required.

14. File for FERC License

Before an FERC exemption can be filed, the developer must obtain all state and local permits. He still needs the dam safety permit. He must repair the dam in order to obtain this permit.

The developer now seeks cost estimates for repairing the dam and removing silt at the stoplog. He contacts a construction contractor and obtains the following information:

- The silt at the stoplog can be removed at a cost of \$1,000
- The concrete on the spillway face can be repaired at a cost of \$3,000
- Riprap can be placed at the toe of the dam for \$1,500
- A total of \$5,500 will have to be spent to repair the dam before a dam safety permit and FERC exemption can be obtained.

The developer decides to bypass this step until the full project cost estimate can be made.

15. Read Section on Turbines

16. Contact Manufacturers and Suppliers

The developer reads Subsections 4.1 and 4.2. Since the old turbine is still in place, he decides to contact the original manufacturer to obtain information on generator availability, inspection services, and repair estimates. Since no name plate exists on the turbine with any data but the manufacturer's name. The developer goes to the county court house to determine the original mill owner and construction date. From old records he determines this information and proceeds to fill out the Microhydropower Turbine Generator Information Request Form of Subsection 4.2.

17. Determine Market Potential

The developer had contacted the state PUC previously with other state agencies. The PUC helps him establish a ballpark price of 55 mills per kWh for electricity.

MICROHYDROPOWER TURBINE-GENERATOR
INFORMATION REQUEST

10/15/81

(DATE)

GENTLEMEN:

I am interested in installing a microhydropower system. The following site specifications are supplied for your evaluation. Please review the specifications and answer any appropriate questions concerning your equipment.

My Name: Joseph Shmoe

Address: Anywhere, NH

Phone No. (602) 123-4367

Project Name: Old Grist Mill

I. REASON FOR DEVELOPMENT

(Check One)

1. I am interested in supplying my own electrical needs. I do not plan to intertie with a utility. Therefore, I will require a synchronous generator.
2. I am interested in supplying my own electrical needs. When my needs are less than the energy produced, I would consider selling to a utility. However, I want to be able to generate power independent of a utility. I therefore require a synchronous generator and speed control equipment.
3. I am interested in supplying my own electrical needs. I want to be able to sell excess power to a utility. An induction generator is acceptable since I do not care to generate power independent of the utility.
4. I am interested in generating as much power as possible for the dollar invested. However, I want a synchronous generator so that I can generate power if the utility service is interrupted.
5. I am interested in generating as much electrical power as possible for the dollar invested. I am not interested in generating independent of the utility.

II. TYPE OF SOURCE AND AMOUNT OF HEAD

(Check One)

- 1. The site is a run-of-the-stream site and can have a pool-to-pool head from _____ to _____ feet.
- 2. The site is an existing dam and has a ~~constant~~/variable pool-to-pool head of 11 to 12.5 feet.
- 3. The site is a canal drop/industrial waste discharge and has a pool-to-pool head of _____ feet.

III. AMOUNT OF FLOW

(Check One)

- 1. The flow values are based on the attached flow duration curve.
- 2. The flow value is based on a minimum stream flow of _____ cfs. This is because my objective is to supply my energy needs as much of the year as I can.
- 3. The flow is available _____ months out of the year and is fairly constant at _____ cfs.
- 4. The flow values are based on monthly averages in cfs:

Jan. _____	May _____	Sept. _____
Feb. _____	Jun. _____	Oct. _____
Mar. _____	Jul. _____	Nov. _____
Apr. _____	Aug. _____	Dec. _____

- 5. Other: See V-9, Additional Information.

IV. PERSONAL POWER NEEDS

A copy of the daily load use table is attached. The daily peak load is estimated to be 21 kW. Major electrical equipment is listed below.

<u>Stove</u>	<u>TV</u>
<u>Washer</u>	<u>Hot water heater</u>
<u>Dryer</u>	<u>Milking machines</u>
<u>Electric heat, 9 kW</u>	<u>Pump, 3/4 hp</u>
<u>Refrigerator, 14 cubic feet</u>	<u>Pasteurizer</u>
<u>Freezer, 15 cubic feet</u>	

The voltage I need is 120/208 , and is ~~single~~/three phase.

V. ADDITIONAL INFORMATION

1. Site location and stream name Anywhere, NH
Cold River
2. Name of local utility Public Utility Corp
Distance to nearest substation is 15 miles.
3. The quality of the water is usually clear/~~murky/silt laden/muddy~~.
4. Site elevation is 1100 feet.
5. Annual average temperature variation is from -35
to 95 °F.
6. A sketch of the site is/~~is not~~ included.
7. Existing structures or equipment that should be used, if possible, include Mill structure; Open-flume Francis turbine, James Leffel & Co.; Woodward Governor
8. The proposed diameter and length of the penstock are (leave blank if not known): _____ inches in diameter, _____ feet in length.
9. Additional information to be considered: The original turbine purchaser was the Brown Mill Co. of Anywhere, NH. It was purchased in 1920. I would like an estimate of turbine refurbishment, generator costs, efficiencies, power production, and annual energy. The turbine is old, and the shaft appears to be heavily rusted. The original generator has been removed, but the turbine, wicket gates, and governor are still installed.

18. Determine Financing Options

After reading Section 7.0, the developer determines that a second mortgage on his land is the only feasible method of financing the development.

19. Make Preliminary Cost Estimate

The turbine manufacturer representative visits the site and inspects the old turbine and layout of the mill. Upon his return, the turbine manufacturer transmits an estimate of turbine and governor repair costs, generator costs, and other electrical equipment costs. These are summarized below:

Generators (90 kVA)	\$10,000
Electrical equipment and governor	\$ 8,000
Turbine and governor repair and modification	<u>\$ 8,000</u>
Total	\$26,000

The manufacturer also provides the following information:

- The estimated net effective head is 11.5 feet (the turbine manufacturer estimates 1 foot of pressure drop in the trashrack and draft tube).
- The turbine-generator efficiency is 70%.
- The annual energy is 319,900 kWh, from Figure B2-4 (this is higher than the developer's estimate but is based on more accurate calculations by the manufacturer).
- The plant Factor is 52%, from Figure B2-4.

The developer contacts a construction contractor to provide an estimate for rebuilding the mill and restoring it as a mid 19th century grist mill as required by the New Hampshire Department of Resources and Economics. He and the contractor agree on a scope of work, and the

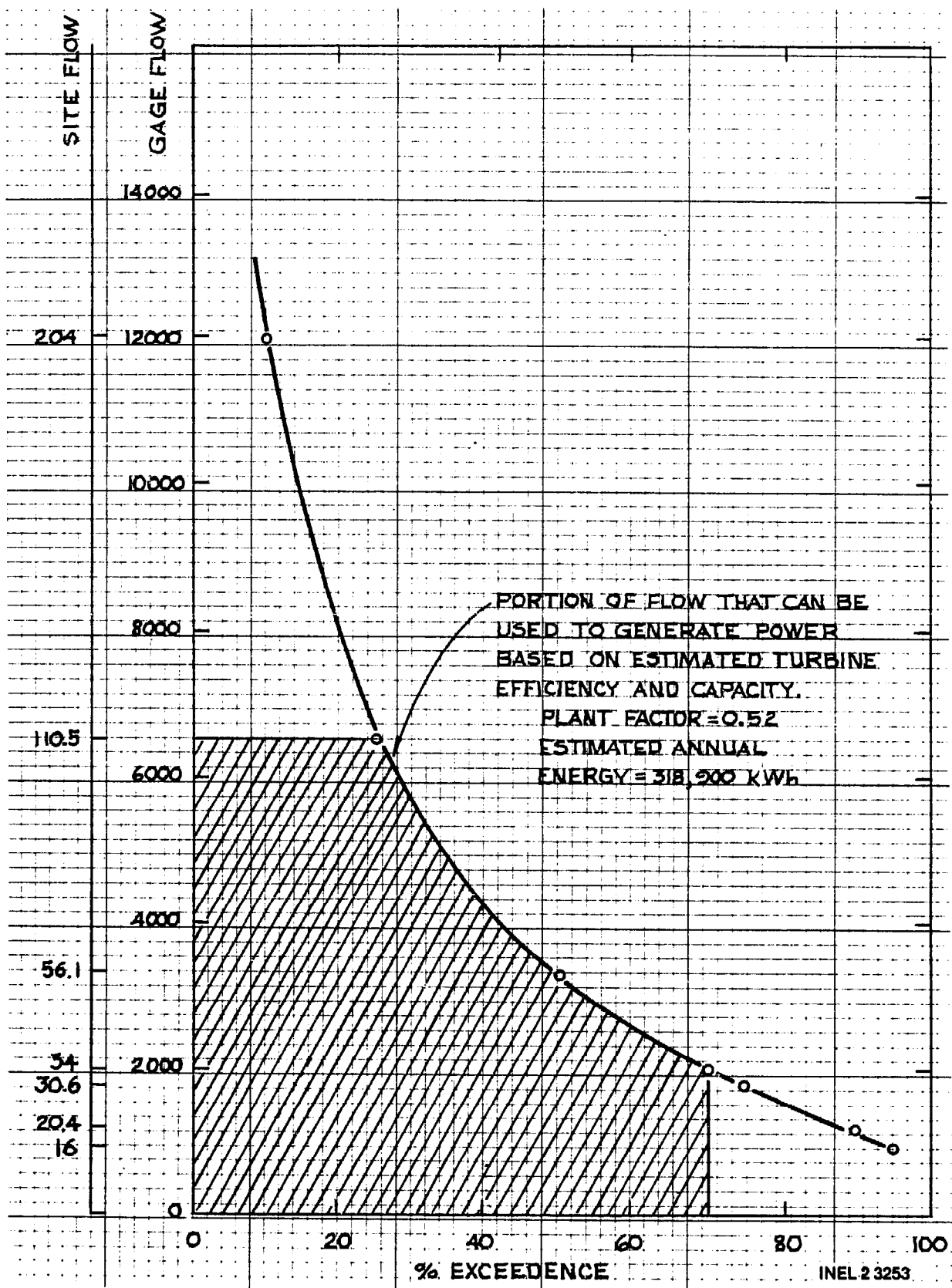

Figure B2-4. Flow duration curve, showing portion of flow that can be used to generate power.

contractor estimates it will cost \$12,000 to perform the work. This includes \$2,500 for an architect to prepare drawings and provide consulting services for the mill's restoration.

The developer now prepares the preliminary cost estimate as discussed in Subsection 4.3.1.

Total Costs are:

Turbine-generator work	\$26,000
Building repair	12,000
Dam repair	<u>5,500</u>
	\$43,500
Administrative costs at 10%	<u>4,350</u>
	\$47,850
Contingency at 25%	<u>11,960</u>
Total	\$59,810

Round up to \$60,000. The cost per kW is now calculated:

$$\frac{\$60,000}{70 \text{ kW}} = \$856/\text{kW}$$

This cost is near the low end of the cost range for microhydropower sites given in Subsection 4.3.1.

20. Go/No-Go

The developer is now at the second Go/No-Go decision.

In order to evaluate the potential of his investment, the developer must perform a cash flow analysis as discussed in Appendix A-5. He performs this analysis on Table B2-3.

This analysis shows that the projected revenue for the sale of power will exceed the costs to pay back the loan plus operating costs plus depreciation.

TABLE B2-3. CASH FLOW ANALYSIS

Capital cost estimate is \$60,000

Estimated value of energy is \$0.055/kWh

Estimated revenue is $318,900 \times 0.055 = \$17,539/\text{year}$

Estimated operating and maintenance costs, from Appendix A-5.3, are $0.01 \times \$60,000 = \$600/\text{year}$

Taxes and insurance are estimated to be \$800/year

Total operating costs are $\$600 + \$800 = \$1400/\text{year}$

Depreciation (Appendix A-5.4):

$SV = 10,000$ (estimate salvage value at the end of life-30 years)

$PC = 43,500$ (60,000 less administrative costs and contingency)

$Y = 30$

$$D = \frac{43,500 - 10,000}{30} = \$1,120/\text{year} \quad (\text{A5-2})$$

Mortgage payment (Appendix A-5.5):

Assume that the bank will finance 80% of costs over a 10-year period.
Interest is presently at 14%.

$0.8 \times \$60,000 = \$48,000$ (funds borrowed from bank)

$$P = \frac{B}{I} \text{ (annual payment for loan)} \quad (\text{A5-3})$$

$B = 48,000$ 10 yrs 14%

$I = 5.2161$ (Table A5-4)

$$P = \frac{48,000}{5.2161} = \$9202$$

TABLE B2-3. (continued)

$$S = P - (B \times i) \text{ (principal repayment)} \quad (A5-4)$$

$$S = 9202 - (48,000 \times 0.14) = 2482 \text{ (first year principal repaid)}$$

Calculate a repayment Table for each year, as described in Appendix A5-5.

<u>Year</u>	<u>Payment</u>	<u>Interest</u>	<u>Principle</u>	<u>Balance</u>
0	0	0	0	48,000
1	9202	6720	2482	45,518
2	9202	6373	2829	42,689
3	9202	5976	3226	39,463
4	9202	5525	3677	35,786
5	9202	5010	4192	31,594
6	9202	4423	4779	26,815
7	9202	3754	5448	21,367
8	9202	2991	6211	15,156
9	9202	2121	7081	8,075
10	9202	1130	8072	3 ~ 0

Yearly loan payment	=	\$ 9,202
Yearly operating costs	=	1,400
Yearly depreciation costs	=	<u>1,120</u>
Total yearly costs	=	\$11,722

Revenue from the sale of power = \$17,539

This is a good investment, and the developer decides to proceed with the development.

21. Select the Design Criteria

The site design criteria should be finalized now. The developer gathers all the information he has on the site and that information furnished by the manufacturers. This is included in a design specification shown in Table B2-4.

The developer hires a contractor to repair the dam. Once the dam is repaired, the state issues the Dam Safety Permit and the developer applies to FERC for his exemption. His application includes all the permits issued by the state as well as the letter from the Fish and Game Department and the Department of Resources and Economics. He includes the plans to restore the mill to mid 19th century appearance.

22. Design the System

The developer begins the design of the needed system components. A construction contractor has been hired to design and perform the building modifications. The developer only has to design the trashrack and electrical systems. He begins with the trashrack design.

Trashrack.

Using Equation (4.4-7) from Subsection 4.4.2.6.2 he calculates the area.

$$A_{DT} = \frac{Q}{0.5}$$

$$Q = 110 \text{ cfs}$$

$$A = \frac{110}{0.5} = 220 \text{ ft}^2$$

Assume trashrack is inclined at 45 degrees. Find the wetted length of the trashrack.

$$L_w = \frac{d_t}{0.707} \tag{4.4-8a}$$

$d_t = 4$ feet measured after the stoplog was cleaned out

$$L_w = \frac{4}{0.707}$$

TABLE B2-4. DESIGN SPECIFICATION

1. Net effective head of 11.5 feet, or pool-to-pool head range from 12.5 to 11.
2. The design flow is 110.5 cfs.
3. Turbine:
 - a. Manufacturer James Leffel & Co.
 - b. Supplier Existing site equipment
 - c. Type Open-flume Francis
 - d. Model No. _____
 - e. Shaft speed at design head and flow 900 rpm
 - f. Diameter of turbine inlet NA inches
 - g. Diameter or dimension of outlet NA inches
 - h. Setting of turbine at throat NA feet above minimum tailwater level.
4. Speed increaser type Direct drive
 ratio NA
 input power 117 kW (Assumes 12.5 ft pool-to pool head and 100% efficiency)
5. Generator:
 - a. Manufacturer General Electric
 - b. Supplier James Leffel & Co.
 - c. Type Induction 900 kVA
 - d. Model No. XYZ
 - e. Operating speed 900
 - f. Voltage 120/208 phase three
6. Wetted weight of equipment NA pounds
7. Dimensions of equipment frame NA feet
8. Load diverter/governor:
 - a. Manufacturer Woodward
 - b. Supplier Existing site equipment
 - c. Type Mechanical
 - d. Model No. MNO

$$L_w = 5.65 \text{ feet}$$

Find the trashrack width (clear area).

$$W_N = \frac{A_{DT}}{L_w} \quad (4.4-9)$$

$$W_N = \frac{220}{5.65} = 38.94 \text{ feet}$$

Width of trashrack using 1/4-inch bars with 1-inch spacing.

$$W_T = r \times W_N \quad (4.4-10)$$

$r = 1.25$ for 1-inch openings

$$W_T = 38.94 \times 1.25 = 48.7 \text{ feet.}$$

Since the width of the trashrack is approximately equal to the width of the reservoir at the intake, the trashrack will have to be designed on a different basis. The developer decides to design the trashrack as follows:

Let $V = 2$ fps (typical inlet channel velocity)

$$A = \frac{Q}{V} \quad V = 2$$

$$A = \frac{Q}{V} = \frac{110}{2} = 55 \text{ ft}^2$$

$$L_w = 5.65$$

$$W_N = \frac{55}{5.65} = 9.76 \text{ feet}$$

$$W_T = 9.76 \times 1.25 = 12.16 \text{ feet}$$

This is much more reasonable, and the developer decides to use a 12-foot-wide trashrack, which will fit the existing stop log structure. The stoplog structure is measured to be 8 feet deep.

Total length of the trashrack:

$$L_A = \frac{H_A}{0.707} \quad (4.4-11a)$$

$H_A = 4$ feet (see Figure B2-1)

$$L_A = \frac{4}{0.707} = 5.65$$

$$L_T = 5.65 + 5.65 = 11.3 \text{ feet or } 11 \text{ feet } 4 \text{ inches}$$

The developer also decides to put a skimmer in front of the stop log structure. He designs it in accordance with Subsection 4.4.2.6.1.

Figure B2-5 shows a plan view of the trashrack, skimmer, and stop log.

Electrical Equipment.

The electrical equipment sizing is the only task left for the developer. He obtains the help of an electrical contractor, and together they size the equipment.

The turbine manufacturer has recommended that the site be developed for a 90-kVA induction generator, three phase WYE connected. The induction generator will be operating with a 0.8 power factor (p.f.) and at 1100 foot elevation. Appendix A-6 defines the actual power produced in kW for a generator to be the power factor times the apparent power (kVA). This will give a machine that will be kW rated as follows: $\text{kW} = \text{p.f.} \times \text{kVA} = 0.8 \text{ p.f.} \times 90 \text{ kVA} = 72 \text{ kW}$. Elevation deration of 3% per 1000 feet above 3300 feet does not apply since the generator is installed at 1100 feet.

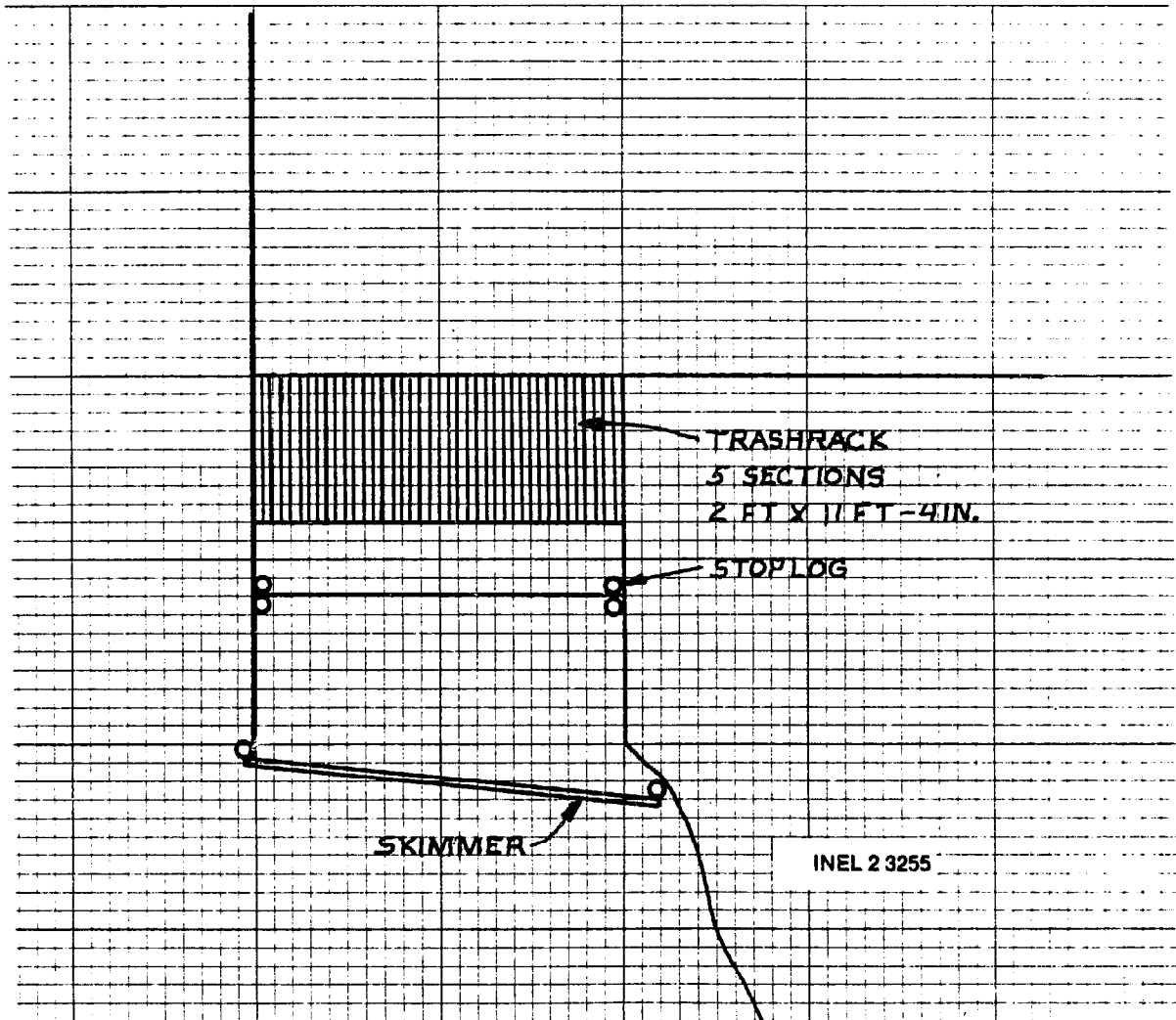

Figure B2-5. Sketch of trashrack, skimmer, and stop log.

The developer now develops a three line-drawing on which all connections, wiring, overcurrent devices, protective devices and equipment are properly shown and rated. This drawing will also help determine the equipment that is needed and make estimating the cost of that equipment easier. Figure B2-6 is a three-line diagram of this example.

Next, the developer sizes the wire and equipment that are connected to the generator. The wiring and equipment are sized in accordance with various sections of the National Electrical Code (NEC). The sections that are used to determine the size of equipment are referenced from the 1981

B2-28

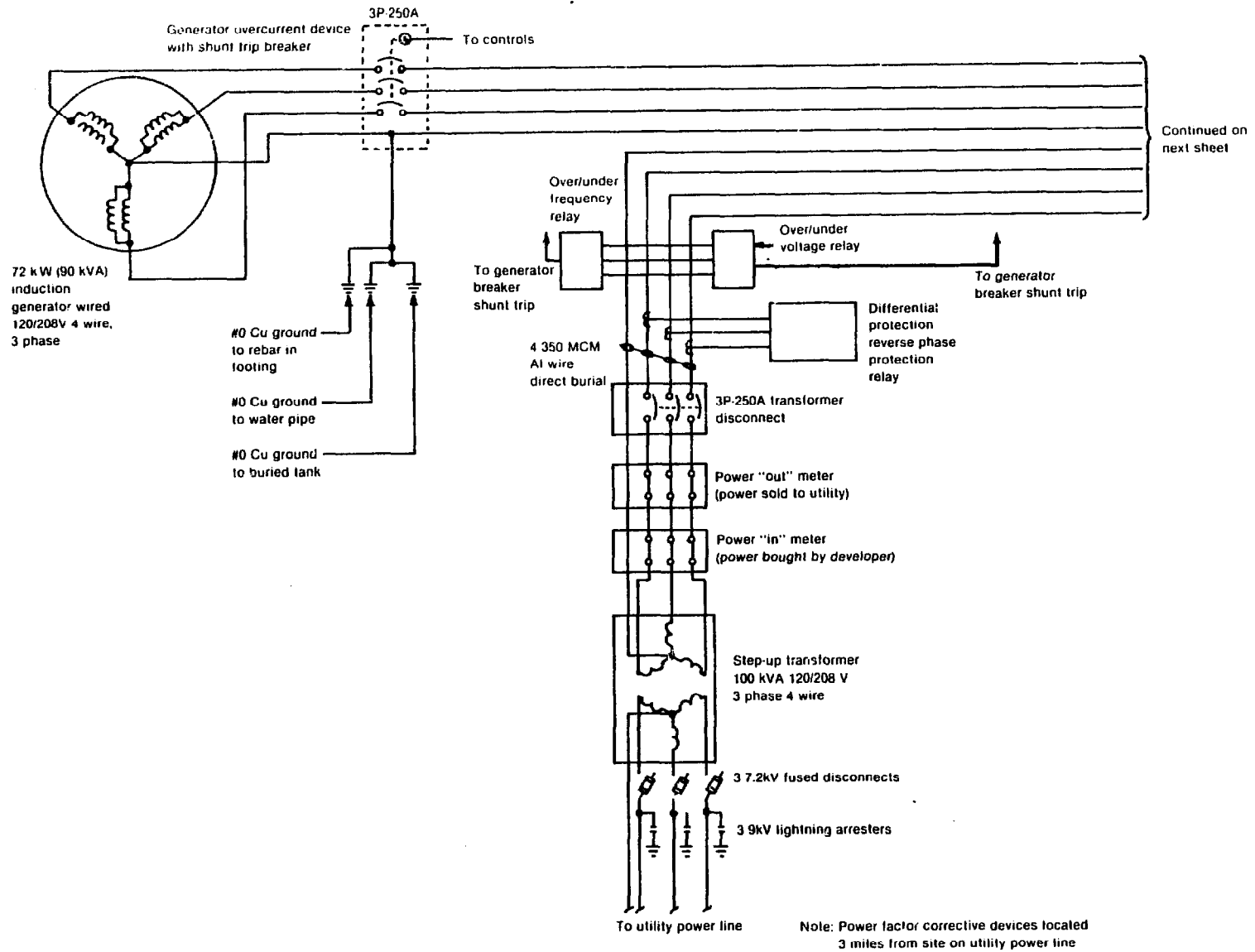
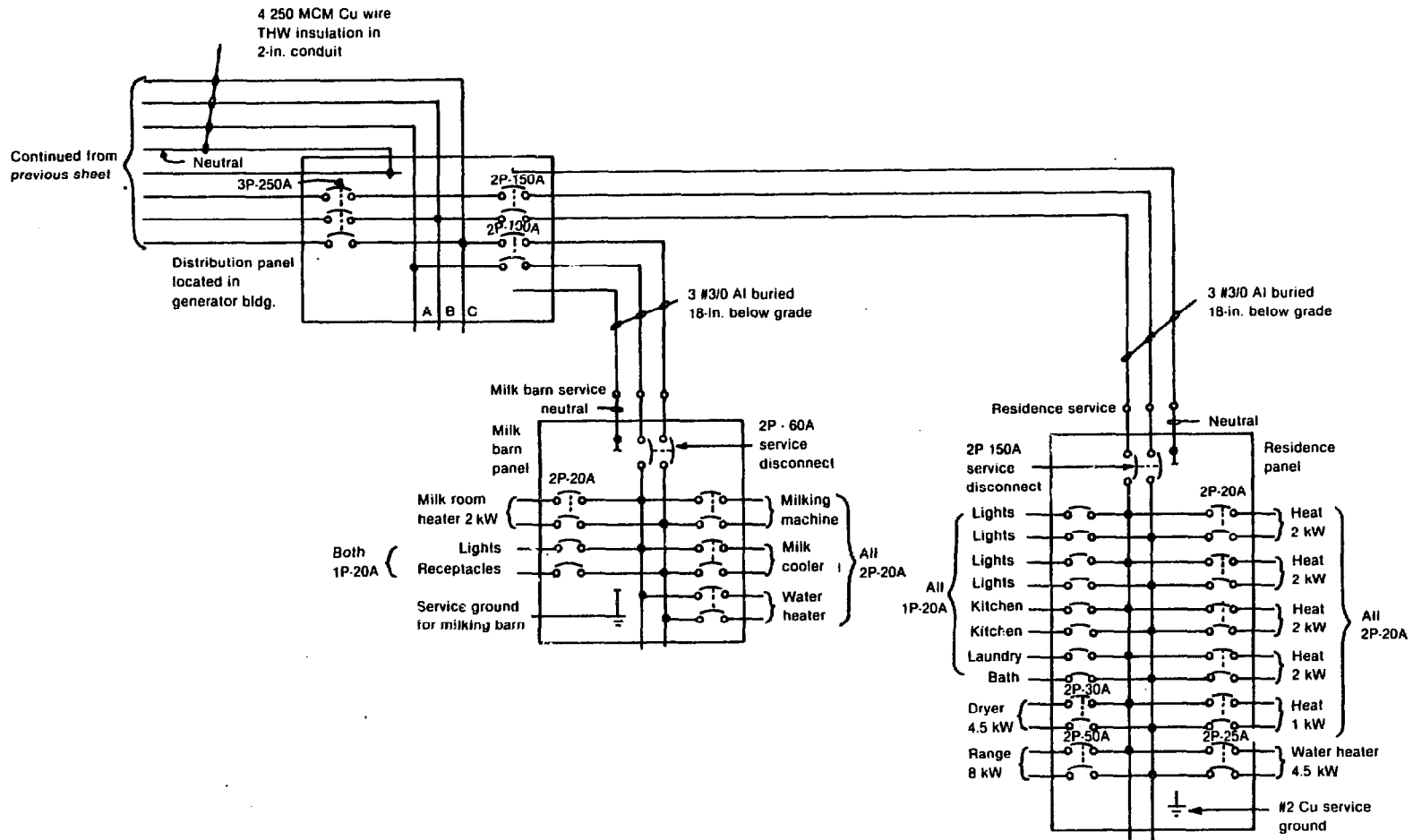

Figure B2-6. Three-line diagram.

INEL 2 2688

B2-29



INEL 2 2686

Figure B2-6. (continued)

NEC. The maximum power output of the generator has been determined to be 72 kW. The voltage level of the system has been selected at 120/208 volts three phase four wire. To size the wire and equipment, the current must be determined. From Equation (A.6-11):

$$P = \sqrt{3} \times E \times I$$

Therefore,

$$I = \frac{P}{\sqrt{3} \times E} = \frac{72,000 \text{ watts}}{1.73 \times 208 \text{ volts}} = 200 \text{ amps}$$

200 amps is the full load of the system.

The services to the residence should have been sized in accordance with NEC Article 220 and could have been derated in accordance with Table 220-30 when it was installed. This states that the minimum ampacity of the residence service was based on loads in the residence and is 120 amps. The owner has installed a 150-amp service to the house.

The milking barn has a maximum load of 4.6 kW. The service has been sized for a minimum 60-amp, 240-volt service.

Voltage Selection--The existing service to the dairy farm is 120/240 volts. This is brought into the farm from a three-phase power line located adjacent to the utility. The owner has looked at installing a 120/240 volt single-phase generator or a 120/208-volt, three-phase, four-wire generator. Investigation has revealed that all existing loads in the residence and dairy that were rated 240 volts single phase would work on 208 volts single phase. The 240-volt heat loads would only be powered at 70% of their rating on 208 volts, which means that the heat loads would heat longer at lower ratings, but would not consume any more power. Therefore, the developer decides to install a 120/208-volt, three-phase, four-wire generator.

Wire Sizing--

- The wire from the generator to the generator overcurrent device per paragraph 445-5 of the NEC shall be sized for 115% of the generator nameplate current. Therefore,

$$I_{\max} = \frac{P}{\sqrt{3} \times E} \times 115\% = \frac{72,000 \text{ watts}}{3 \times 208 \text{ volts}} \times 115\% = 230 \text{ amps}$$

- The wire from the generator overcurrent device to the distribution panel per paragraph 220-10b of the NEC requires feeder conductors and overcurrent devices rated to handle the noncontinuous load plus 125% of the continuous loads. The maximum output of the generator will be continuous. Therefore,

$$I_{\min} = \frac{P}{\sqrt{3} \times E} \times 115\% = \frac{72,000 \text{ watts}}{3 \times 208 \text{ volts}} \times 115\% = 250 \text{ amps}$$

Wire size, taken from Table 310-16 of the NEC for a copper conductor and ampacity of 250 amps, will be a No. 250 MCM copper with THW insulation.

- The wire from the distribution panel to the residence will be sized to supply the house service requirements of 150 amps, 208 volts single phase.

The minimum ampacity will be 150 amps. However, it is desired to use aluminum wire because it is cheaper for the longer runs. Also, the insulation for the wire must be acceptable for direct burial in the earth. This requires Type USE (Underground Service Entrance).

Again from Table 310-16 of the NEC, the minimum aluminum wire size for 150-amps will be No. 3/0 aluminum with Type USE insulation. (Voltage drop does not need to be taken into consideration for these calculations because the generator is located near the buildings.)

- The feeder to the dairy barn is desired to be 240-volt, 60-amp service. (This service is oversized to accommodate future loads.)

The wire is then selected for a minimum ampacity of 60 amps. The conductor will be aluminum, direct burial. Therefore, from Table 310-16 of the NEC, the minimum conductor will be No. 4 AWG aluminum with Type USE insulation.

- The feeder from the distribution panel board to the utility transformer must be of sufficient capacity to handle the full generator output. This feeder will be rated to carry 200 amps continuously or for 250 amps. From Table 310-16, the minimum wire is 350 MCM aluminum with Type USE insulation.

The transformer is located 300 feet away. A voltage drop calculation is as follows:

$$E_d = I \times R$$

where

$$I = 200 \text{ amps}$$

$$R = \frac{0.0505}{1000} \times 300 \text{ (resistance per 1000 feet x distance in feet)}$$

$$E_d = 200 \text{ amps} \times 0.0505 \text{ ohm/1000 feet} \times 300 \text{ feet} = 3.03 \text{ volts}$$

$$\% \text{ drop} = \frac{E_d}{E} \times 100\% = \frac{3.03}{208} = 1\%$$

Therefore, the voltage drop is not a problem. The owner can size the feeder from the feeder panel to the transformer to handle the generator output amperes only.

NOTE: Aluminum wire is cheaper to install than copper in some cases. However, it requires special handling and antioxidation compounds. Check with an electrical supplier for proper installation techniques for aluminum conductors.

Overcurrent Protection Sizing--As stated above, overcurrent protection devices must be sized to handle 125% of the continuous load that they handle. Paragraph 240-3, Exception No. 1 of NEC allows the next higher breaker rating to be used where the ampacity of a conductor does not correspond to a standard device rating.

Therefore, the overcurrent devices (circuit breakers for this example) can be sized for the wire ampacities.

- The generator breaker will be sized for 125% of the full load rating of the generator, which is 250 amps as determined above. Therefore, the developer will use a standard 250-amp breaker. This breaker will be capable of being remotely tripped to meet the requirements of the utility for protective relaying.
- Residence feeder breakers will be sized for the residence service, or 150 amps 240 volts. The developer will use a 150-amp, two-pole breaker.
- The feeder to the dairy barn was selected at 60 amps 240 volts. The developer will use a 60-amp, two-pole breaker.
- The feeder to the power line must be capable of handling the full rated output of the generator. Therefore, the overcurrent device must be rated for full loads amps at three-phase power, or 3P-250 amps.

Distribution Panels--The panels in the residence are existing. The distribution panel needs to be installed to collect and distribute the generator loads.

Since the minimum ampacity of the generator conductors and overcurrent devices has been determined to be 81 amps, the main distribution panel needs to be sized to handle this load.

Standard panel ratings are 100 amps, 225 amps, and up. Therefore, a 250-amp panel will suffice if it can handle a 250-amp and 150-amp circuit breaker.

Service Disconnect--A separate service disconnect has been included in all buildings as required by the NEC paragraph 230-84. In the residence and the barn, the service disconnect will be located in the power panel.

Grounding--Ground wire sizes have been determined in accordance with Table 250-94 of the NEC.

- The residence has a No. 2/OAL service conductor. Therefore, the developer will use a #6 copper minimum ground wire.
- The dairy barn feeder is No. 4. Therefore, the developer will use a #80 copper minimum ground wire.
- The grounding of the generator is important to minimize ground current problems. The NEC requires a minimum ground wire size of #2. However, the developer has talked to a supplier and has decided to install a larger ground wire on his generator. Therefore, he will use a No. 0 AWG copper ground wire for the generator ground.

Power System Interties--Now the developer must determine the power system interconnection requirements. He contacts the power company to determine what their requirements are to intertie with with power line.

This example uses the criteria that the utility requires the developer to provide all the interconnection devices such as transformers, primary and secondary disconnects, and lightning arrestors on the primary power line.

The transformer is sized to handle the generator's full load kVA. The generator is rated at 90 kVA. A 100-kVA transformer was selected.

Overcurrent protection on the secondary of the transformer is sized at generator-rated full-load amps times 125%, or 250 amps. This is smaller than the transformer maximum ampacity, but is acceptable. Primary overcurrent protection for the transformer is based on 125% of generator output and not the transformer rating.

Metering required is power "in" metering for power that the developer buys when the microhydro system is down for repairs, maintenance, or low water levels. A power "out" meter is installed to meter power sold to the utility. These meters are to be tested and calibrated every 2 years, with the developer paying for the testing and calibration.

The utility requires that the generator and power system have additional protection other than overcurrent protection for safe shutdown of the power line. These additional relays are over/under frequency protection, over/under voltage protection, and phase differential/phase reversal protection. These devices are required to trip the generator off line when they sense a problem. Therefore, the generator overcurrent breaker has a shunt trip mechanism that is activated by the protective relays.

The power company requires a minimum 0.9 power factor, and since the generator used has a 0.8 power factor, the owner has to purchase power factor correction devices for the power company to install on the power line. The power company elects to install the devices 3 miles away.

23. Assemble the Design Package

All drawings, data sheets, specifications, and other design information for the site are assembled in a design package as discussed in Subsection 5.1.

24. Negotiate an Equipment Package

The developer prepares bid packages for the turbine-generator work, building restoration, and electrical work. He issues these bid packages and receives firm bids for all items needed to build the site.

25. Make a Project Cost Estimate

The developer takes the bids and invoices from work he has already had performed (e.g. dam refurbishment, turbine inspection) and prepares a final cost estimate. This estimate is shown in Table B2-5.

26. Go/No-Go

The developer is at the final Go/No-Go decision as discussed in Subsection 5.1. The original cost estimate was for \$60,000, whereas the final estimate came to \$65,310. A quick check of the cash flow analysis shows that the developer can still make a profit. See Table B2-3 for explanation of calculations.

Mortgage Payment.

$$0.8 \times \$65,310 = \$52,248 \quad \$52,250$$

Annual Loan Payment.

$$P = \frac{B}{I} \qquad (A5-3)$$

where

$$B = 52,250$$

$$I = 5.2161 \text{ (from Table A5-4)}$$

TABLE B2-5. FINAL COST ESTIMATE

<u>Cost Item</u>	<u>Material</u>	<u>Labor</u>	<u>Total</u>
Generator	\$10,500		\$10,500
Generator overcurrent device with shunt trip	350	25	375
Distribution panel board	400	100	500
Conduit	75	100	175
Wire	1,500	300	1,800
Transformer 100 kVA 3 Ω Padmount	2,000	300	2,300
Transformer secondary overcurrent device	250	50	300
Transformer primary overcurrent device	150	100	250
Power pole (1 ea.)	300	400	700
Lightning arresters	100	100	200
Power factor capacitors	450	--	450
Over/under frequency relay	400	100	500
Over/under voltage relay	450	100	550
Phase differential/phase reversal relay	500	100	600
C.T.'s	100	100	200
Meter "in"	250	50	300
Meter "out"	250	50	300
Miscellaneous fittings, etc.	500	500	1,000
Turbine inspection			\$1,000
Turbine and governor repairs			\$5,000
Building repair			\$15,000
Dam repairs			\$5,500
			<u>\$47,500</u>
10% administration cost			4,750
			<u>52,250</u>
25% contingency			13,060
			<u>\$65,310</u>

$$P = \frac{52,250}{5.2161} = \$10,017$$

Operating Costs.

Taxes and insurance	\$ 800
Operating and maintenance costs (0.01 x \$65,310)	<u>653</u>
Total operating costs	\$1,453

Depreciation.

$$D = \frac{47,500 - 10,000}{30} = \$1,250$$

Annual Costs.

$$\$10,017 + \$1,453 + \$1,250 = \$12,720$$

This is still a profitable investment since costs are less than the projected annual revenue of \$17,539 per year (see Table B2-3).

27. Obtain FERC License

The developer receives his exemption from FERC after the 30-day waiting period.

28. Finalize the Marketing Contract

The developer now contacts the local utility to negotiate a price for the sale of his power. After considerable negotiation, a price of 57 mills

per kWh is agreed to. This is higher than the developer has projected, making his site more attractive for development.

29. Develop Financial Package

The developer assembles his design package with cost estimates, utility agreement, FERC exemption, permits, and other backup information for presentation to a lending institution.

30. Obtain Financing

With the information assembled in Step 29, the developer negotiates a loan with the local bank. The interest is 14% and is to be paid back in 10 years, as his cash flow analysis assumed. He mortgages his land to obtain the loan.

31. Finalize Design

The developer orders his equipment and obtains final installation details of the equipment from the manufacturers.

32. Obtain Local Building Permit

33. Construct the System

The developer obtains a county building permit and begins construction.

34. Operate the System

Operation of the facility begins after construction. The developer uses Section 6.0 as a guide.

APPENDIX C

DISCUSSION OF FEDERAL LAWS
AND FEDERAL LAND-USE PERMITS

<u>National Environmental Policy Act (NEPA)--P.L. 91-190</u>	C-1
<u>Fish and Wildlife Coordination Act--P.L. 85-264</u>	C-1
<u>Endangered Species Act--P.L. 93-205</u>	C-2
<u>National Historic Preservation Act--P.L. 89-655</u>	C-2
<u>Federal Water Pollution Control Act--P.L. 92-500</u>	C-3
<u>Water Quality Improvement Act--P.L. 91-224</u>	C-3
<u>Wild and Scenic Rivers Act--P.L. 90-542</u>	C-4
<u>National Wilderness Preservation Act--P.L. 88-577</u>	C-4
<u>Coastal Zone Management Act--P.L. 92-583</u>	C-4
<u>Federal Land Policy and Management Act--P.L. 94-579</u>	C-5
<u>Federal Land-Use Permits</u>	C-5
U.S. Forest Service Land	C-5
U.S. Bureau of Land Management (BLM) Land	C-7
Other Federal Lands	C-7

National Environment Policy Act (NEPA)--P.L. 91-190

The National Environmental Policy Act requires the presentation of an environmental assessment or an environmental impact statement for all development or construction projects involving government lands or Federal funding. Section 102 of the act mentions that all Federal agencies must report on major Federal actions significantly affecting the quality of the human environment. The impact of most microhydropower developments will be small, and the principal concern will be any involvement the developer has with a Federal agency. This act requires that the responsible Federal agency evaluate the impact of its action on the environment. Thus, the FERC must consider the environmental impact of licensing or exempting a microhydropower development. Where the impact is negligible, which should be the case for most microhydropower developments, a negative declaration stating the lack of significant impact will be the most common result. If the impact of a microhydropower project on the environment is significant, hearings and perhaps an environmental impact statement may be necessary. This is a very costly process and would render most microhydropower projects uneconomical. The addresses of the most frequently involved Federal agencies are shown in Appendices D-1 through D-6. The agency to contact with regard to NEPA P.L. 91-190, is the U.S. Environmental Protection Agency (EPA). Addresses of EPA offices are given in Appendix D-2.

Fish and Wildlife Coordination Act--P.L. 85-624

The Fish and Wildlife Coordination Act provides that "whenever the water of any stream or other body of water are proposed or authorized to be impounded, diverted, the channel deepened or the stream or other body of water otherwise controlled or modified for any purpose whatever," the U.S. Fish and Wildlife Service, Department of the Interior, must be consulted. For microhydropower development, it may appear that this would be unnecessary, but early contact with a regional office of the U.S. Fish and Wildlife Service should be made to clarify what must be done to meet the requirements of this law. In many cases, a letter of negative declaration will be necessary to get an FERC exemption or license. U.S. Fish and Wildlife Service office addresses are listed in Appendix D-3.

Endangered Species Act--P.L. 93-205

Provisions of the Endangered Species Act apply to Federal government actions, including FERC licensing, that affect microhydropower developments. Through this act, the government has acquired and set aside protected areas of natural habitat for endangered and threatened species. These include a variety of species of birds, aquatic life, land animals, and plant life. Normally, human activities in these protected areas are closely restricted, and so development of microhydropower in such areas may not be possible. The agencies to contact, where their lands are involved, are the U.S. Fish and Wildlife Service, the state Fish and Game Department in the particular state, the U.S. Forest Service, the U.S. Bureau of Land Management, and the U.S. National Park Service. These agencies have lists of endangered species and the habitat areas involved. Normally, local inquiry will quickly reveal if an endangered species is involved.

National Historic Preservation Act--P.L. 89-665

Provisions of the National Historic Preservation Act require the licensing agency, the FERC in this case, to ascertain if a historical or archeological site will be affected by a microhydropower development. Either FERC or the developer must contact the National Park Service of the U.S. Department of the Interior or the equivalent state agency to check on what specific action needs to be taken. The National Park Service now maintains a National Register of Historic Places (formerly maintained by the National Council on Historic Preservation), and it is authorized to consider sites not on the list if they include historic or archeological items that are eligible for inclusion in the National Register. A developer should consult the Park Service or the equivalent state agency, or examine the National Register of Historic Places in the reconnaissance stage of the project. Addresses for contacting the National Park Services are given in Appendix D-4. Addresses of state agencies responsible for archeological and historic preservation are listed in Appendix E-7.

Federal Water Pollution Control Act--P.L. 92-500

The Federal Water Pollution Control Act provides for control of water quality in the streams of the United States. Obtaining permits under Sections 402 and 404 of this act is discussed in Subsection 8.3, Federal Requirements, of the handbook, and specific details on environmental problems that may be encountered are presented in Subsection 8.1, Environmental Considerations. The Federal Water Pollution Control Act and previous Federal laws require states to set up certain water quality standards. Under the provisions of P.L. 92-500, microhydropower developers must meet the specified water quality standards. Applicable water quality requirements can be obtained from the state agency concerned with water pollution control, which frequently administer the water quality control mandates legislated under P.L. 92-500, or from the nearest EPA office. State water quality control agency addresses are given in Appendix E-4, and EPA addresses are listed in Appendix D-2.

Water Quality Improvement Act--P.L. 91-224

Section 21 of the Water Quality Improvement Act specifies that any applicant for a Federal license or permit to conduct any activity that may result in discharge into the navigable waters of the United States shall provide certification from the state in which the discharge originates giving reasonable assurance that such activity will not violate the applicable water quality standards. This certification also covers certain aspects of the EPA "402 permits," and if the certification is verified, the action can serve both requirements. In some cases, the jurisdiction for administration may be with an interstate agency that supervises the water quality control on a river basin or lake system. The microhydropower developer should contact the water quality control agency of the particular state to obtain a certification or waiver stating that the development will have negligible impact on water quality. State agencies that have responsibility for Section 21 certification are listed in Appendix E-4.

Wild and Scenic Rivers Act--P.L. 90-542

The Wild and Scenic Rivers Act provides for setting aside portions of certain select rivers to maintain their free flowing state, to preserve water quality, and to protect the environment in a corridor along the river. It is not possible to install hydropower developments on such rivers. Microhydropower developments on tributary streams to rivers designated as wild and scenic rivers are not likely to be prohibited. Regulations concerning wild and scenic rivers in general and the specific rivers and areas involved can be obtained from the U.S. Forest Service, the U.S. Bureau of Land Management, or the U.S. National Park Service. Addresses for offices of these agencies are listed in Appendices D-5 and D-4.

National Wilderness Preservation Act--P.L. 88-577

The National Wilderness Preservation Act provides for setting aside certain areas where activities by man are limited, with the idea that the primeval character of the area be protected. Normally, no man-made facilities are permitted nor are any mechanical motorized activities or facilities allowed. An unusual provision of the act is the power given the President of the United States for the establishment and maintenance of reservoirs, water conservation works, power projects, transmission lines, and other facilities needed in the public interest. It is not likely that microhydropower developments will be permitted in National Wilderness Areas unless the development is necessary for maintaining the integrity of the area as a public interest consideration.

Coastal Zone Management Act--P.L. 92-583

The Coastal Zone Management Act, like the Clean Water Act, requires that before a Federal license can be issued for a microhydropower development in a coastal zone (as defined in the act), a certificate of compliance must be obtained. This document must certify that the proposed project complies with the state's comprehensive plan, as required under the act for the protection of coastal areas in any state having a coastline.

Federal Land Policy and Management Act--P.L. 94-579

The Federal Land Policy and Management Act is a comprehensive act that calls for classification of all public lands. Through this act and previous action, the U.S. Congress has withdrawn certain lands and designated or dedicated them as public lands for specific purposes. The two agencies that administer public lands in general are the Forest Service in the U.S. Department of Agriculture and the Bureau of Land Management in the U.S. Department of the Interior. The National Park Service of the U.S. Department of Interior also administers considerable Federal land, but microhydropower development would not be permitted on National Park lands. Because developing microhydropower on Federal lands encompasses a unique and yet somewhat common series of problems, a separate subsection follows on the subject of Federal lands.

Federal Land-Use Permits

A fairly common situation in the western United States is for a microhydropower development to involve the use of Federal land. Four situations are possible:

- o The site for actual construction of the plant is on Federal land.
- o The penstock or water conveyance facilities cross Federal land.
- o The electrical transmission lines cross Federal land.
- o The access roads for the development cross Federal land.

Usually, the developer does not purchase the development site land or the right-of-way for water conveyance facilities, transmission lines, or roads. The appropriate procedure is to obtain a special use permit, lease, right-of-way, or term permit from the particular agency involved.

U.S. Forest Service Land. The U.S. Forest Service regulations specifically state that special use authorization can be issued for:

"Systems and related facilities for generation, transmission and distribution of electrical energy, except that the applicant in addition to obtaining a Forest Service special use authorization, shall also comply with applicable requirements of the Federal Energy Regulatory Commission under the Federal Power Act of 1935, as amended."

The content of an application for a special use permit or lease is specified by regulations entitled, "National Forest System Land: Special Uses" as printed in the Federal Register, U.S. Department of Agriculture Part VI, June 6, 1980, Paragraphs 1 through 5. In general, the application information must contain:

- o Applicant identification
- o Technical and financial capability
- o Project description
- o Environmental protection plan.

Application for special uses and leases should be filed with the Forest Supervisor having jurisdiction over the land affected. The authorized receiving officer will acknowledge the application in writing. Processing of the application will require time for consultation with other agencies, including state and local officials. Where a generation facility and transmission lines of 66 kV or more are involved, the Forest Service official is required to notify the secretary of the U.S. Department of Energy. A rental fee, paid in advance, will be required. The fee will be based on the fair market value of rights and privileges as determined by appraisal or sound business management principles. Under such a permit, the developer is required to maintain the facilities in satisfactory and safe operating condition. To comply, the developer must allow a certain degree of inspection. The permits and leases have specified terms of applicability. Some U.S. Forest Service offices may have special publications to aid the developer of projects using the resources of Forest Service lands. A typical publication is one entitled, "Water-Related Projects Guide, Lolo National Forest."

U.S. Bureau of Land Management (BLM) Land. The U.S. Bureau of Land Management has similar authority to make leases and issue special use permits. Provisions of the Federal Land Policy and Management Act, P.L. 94-579, require that the regulations be as similar as possible under the respective missions of the particular agencies. The U.S. Bureau of Land Management and the U.S. Geological Survey maintain records and maps that define those lands withdrawn by the Federal government for hydropower development, and also other lands dedicated to special uses like mineral development or set aside as wilderness areas and sanctuaries. Principal offices of the U.S. Forest Service and the U.S. Bureau of Land Management are listed in Appendix D-5. Addresses and phone numbers of appropriate Federal agencies can be found in local telephone directories. Frequently, the offices are in Federal buildings in the community.

Other Federal Lands. Occasionally, other Federal lands may offer opportunity for microhydropower development. These could include the lands surrounding dams and impoundments of Federal projects developed by the U.S. Army Corps of Engineers and the U.S. Bureau of Reclamation. Recent policy appears to favor private development at Federal dams if such developments can be accomplished in a cost effective manner without jeopardizing the established functions for which the dams or impoundments were built. Normally, developments at these sites will be much larger than microhydropower size. U.S. Corps of Engineers district and division office addresses are presented in Appendix D-1, and U.S. Bureau of Reclamation regional office addresses are presented in Appendix D-6.

The Tennessee Valley Authority (TVA), as a Federal government corporation, also has jurisdiction over certain dams, river control works, and impoundments that might provide opportunity for developing microhydropower plants. Under rules presented in the Federal Register (Vol. 46, No. 93, May 14, 1981), the TVA has issued a policy to encourage dispersed power production.

APPENDIX D

ADDRESSES OF FEDERAL OFFICES

D-1	U.S. Army Corps of Engineers Offices	D1-i
D-2	Environmental Protection Agency Offices	D2-i
D-3	Fish and Wildlife Service, U.S. Department of Interior National and Regional Offices	D3-i
D-4	National Park Service, U.S. Department of Interior, National and Regional Offices	D4-i
D-5	Forest Service, U.S. Department of Agriculture and Bureau of Land Management, U.S. Department of Interior, National and Regional Offices	D5-i
D-6	Bureau of Reclamation, U.S. Department of Interior, National and Regional Offices	D6-i
D-7	Federal Marketing Entities, Administration Offices	D7-i

APPENDIX D-1

U.S. ARMY CORPS OF ENGINEERS OFFICES

Alaska

The District Engineer,
U.S. Army Engineer District
P.O. Box 7002
Anchorage, AK 99510
NPACO-RF

907 752-4942

Albuquerque

The District Engineer
U.S. Army Engineer District
P.O. Box 1580
Albuquerque, NM 87103
SWACO-OR

505 766-2776

Baltimore

The District Engineer
U.S. Army Engineer District
P.O. Box 1715
Baltimore, MD 21203
NABOP-F

301 962-3670

Buffalo

The District Engineer
U.S. Army Engineer District
1776 Niagara St.
Buffalo, NY 14207
BCBCO-S

716 876-5454

Charleston

The District Engineer
U.S. Army Engineer District
P.O. Box 919
Charleston, SC 29402
SACCO-P

803 577-4171

Chicago

The District Engineer
U.S. Army Engineer District
219 S. Dearborn St.
Chicago, IL 60604
NCCCO-SP

312 353-6434

Detroit

The District Engineer
U.S. Army Engineer District
P. O. Box 1027
Detroit, MI 48231
NCECO-L

313 226-6813

Ft. Worth

The District Engineer
U.S. Army Engineer District
P.O. Box 17300
Ft. Worth, TX 76102
SWFOD-P

817 334-2814

Galveston

The District Engineer
U.S. Army Engineer District
P.O. Box 1229
Galveston, TX 77553
SWGCO-OC

713 763-1211

Huntington

The District Engineer
U.S. Army Engineer District
P.O. Box 2127
Huntington, WV 25721
ORHOP-WP

304 529-2318

Honolulu

The District Engineer
U.S. Army Engineer District
Bldg 230, Ft. Shaffer
Honolulu, HI
PODCO-O

808 438-9258

Jacksonville

The District Engineer
U.S. Army Engineer District
P.O. Box 4970
Jacksonville, FL 32201
SAJOD-RP

904 791-2211

Kansas City

The District Engineer
U.S. Army Engineer District
700 Fed. Bldg
601 E. 12th St.
Kansas City, MO 64106
MRKOD-P

816 374-3645

Little Rock

The District Engineer
U.S. Army Engineer District
P.O. Box 867
Little Rock, AR 72203
SWLCO-D

501 378-5296

Los Angeles

The District Engineer
U.S. Army Engineer District
P.O. Box 2711
Los Angeles, CA 90053
SPLCO-N

213 688-5607

Louisville

The District Engineer
U.S. Army Engineer District
P.O. Box 59
Louisville, KY 40201
ORLOP-SP

502 582-6461

Memphis

The District Engineer
U.S. Army Engineer District
668 Fed. Ofc Bldg
Memphis, TN 38103
LMMOD-NN

901 521-3471

Mobile

The District Engineer
U.S. Army Engineer District
P.O. Box 2288
Mobile, AL 36628
SAMOP-S

205 690-2660

Nashville

The District Engineer
U.S. Army Engineer District
P.O. Box 1070
Nashville, TN 37202
ORNOP-F

615 251-5181

New Orleans

The District Engineer
U.S. Army Engineer District
P.O. Box 60267
New Orleans, LA 70160
LMNOD-S

504 865-1121

New York

The District Engineer
U.S. Army Engineer District
26 Fed. Plaza
New York, NY 10007
NANOP-E

212 264-3996

Norfolk

The District Engineer
U.S. Army Engineer District
803 Front St.
Norfolk, VA 23510
NAOOP-P

804446-3652

Omaha

The District Engineer
U.S. Army Engineer District
6014 USPO & Courthouse
215 N. 17th St.
Omaha, NE 68102
MROOP-N

402 221-4133

Philadelphia

The District Engineer
U.S. Army Engineer District
US Custom House
2nd & Chestnut St.
Philadelphia, PA 19106
NAPOP-R

215 597-2812

Pittsburgh

The District Engineer
U.S. Army Engineer District
1884 Fed Bldg
1000 Liberty Ave.
Pittsburgh, PA 15222
ORPOP-S

412 644-6872

Portland

The District Engineer
U.S. Army Engineer District
P. O. Box 2946
Portland, OR 97208
NPPND-RF

503 221-6997

Rock Island

The District Engineer
U.S. Army Engineer District
Clock Tower Bldg
Rock Island, IL 61201
NCROD-S

309 788-6361

Sacramento

The District Engineer
U.S. Army Engineer District
650 Capitol Mall
Sacramento, CA 95814
SPKCO-O

916 440-2327

St. Louis

The District Engineer
U.S. Army Engineer District
210 No. 12th
St. Louis, MO 63101
LMSOD-NP

314 268-2872

St. Paul

The District Engineer
U.S. Army Engineer District
1135 USPO & Custom House
St. Paul, MN 56101
NCSCO-S

612 725-5819

San Francisco

The District Engineer
U.S. Army Engineer District
211 Main St.
San Francisco, CA 94105
SPNCO-R

415 556-2752

Savannah

The District Engineer
U.S. Army Engineer District
P.O. Box 889
Savannah, GA 31402
SASOP-F

912 233-8822

Seattle

The District Engineer
U.S. Army Engineer District
P.O. Box 3-3755
Seattle, WA 98134
NPSOP-RF

206 764-3495

Tulsa

The District Engineer
U.S. Army Engineer District
P. O. Box 51
Tulsa, OK 74102
SWTOD-N

918 581-7351

Vicksburg

The District Engineer
U.S. Army Engineer District
P.O. Box 50
Vicksburg, MS 39180
LMKOD-F

001 636-1311

Walla Walla

The District Engineer
U.S. Army Engineer District
Bldg 602, City-County Airport
Walla Walla, WA 99362
NPWOP-NF

509 525-5500

Wilmington

The District Engineer
U.S. Army Engineer District
P.O. Box 1890
Wilmington, NC 26401
SAWCO-E

919 763-9971

New England

The District Engineer
U.S. Army Engineer District
424 Trapelo Road
Waltham, MA 02154
NEDOD-R

617 894-2400

APPENDIX D-2

ENVIRONMENTAL PROTECTION AGENCY OFFICES

Administrator
U.S. Environmental Protection Agency
Waterside Mall
4th & M Streets, SW.
Washington, DC 20460

(202) 755-2700

Region I

Regional Administrator
Region I, EPA
2203 Kennedy Fed. Bldg.
Boston, MA 02203

(617) 223-2525

Region II

Regional Administrator
Region II, EPA
26 Federal Plaza, Rm 1009
New York, NY 100-7

(212) 264-2525

Region III

Regional Administrator
Region III, EPA
6th & Walnut Streets
Philadelphia, PA 19106

(215) 597-9814

Region IV

Regional Administrator
Region IV, EPA
345 Courtland Street, NE
Atlanta, GA 30365

(404) 881-4727

Region V

Regional Administrator
Region V, EPA
230 S. Dearborn Street
Chicago, IL 60604

(312) 353-2000

Region VI

Regional Administrator
Region VI, EPA
First International Bldg
1201 Elm Street
Dallas, TX 75270

(214) 767-2600

Region VII

Regional Administrator
Region VII, EPA
324 E. 11th Street
Kansas City, MO 64106

(816) 374-5493

Region VIII

Regional Administrator
Region VIII, EPA
1860 Lincoln Street
Suite 900
Denver, CO 80203

(303) 837-3895

Region IX

Regional Administrator
Region IX, EPA
215 Fremont Street
San Francisco, CA 94105

(415) 556-2320

Region X

Regional Administrator
Region X, EPA
1200 6th Avenue
Seattle, WA 98101

(206) 442-1200

APPENDIX D-3

FISH AND WILDLIFE SERVICE,
U.S. DEPARTMENT OF INTERIOR,
NATIONAL AND REGIONAL OFFICES

Region 1

Director
Region 1
Fish & Wildlife Service
Interior Department
Multnomah Street
Portland, OR 97208

(503) 231-6118
FTS 429-6118

Region 2

Director
Region 2
Fish & Wildlife Service
Interior Department
P.O. Box 1306
Albuquerque, NM 87103

(505) 766-2321
FTS 474-2321

Region 3

Director
Region 3
Fish & Wildlife Service
Interior Department
Federal Building, Fort Snelling
Twin Cities, MN 56111

(612) 725-3563
FTS 725-3563

Region 4

Director
Region 4
Fish & Wildlife Service
Interior Department 500 NE
75 Spring Street, SW
Atlanta, GA 30303

(404) 221-3588
FTS 242-3588

Region 5

Director
Region 5
Fish & Wildlife Service
Interior Department
One Gateway Center, Suite 700
Newton Corner, MA 02158

(617) 965-5100
FTS 829-9200

Region 6

Director
Region 6
Fish & Wildlife Service
Interior Department
P.O. Box 25486
Denver, CO 80225

(303) 234-2209
FTS 234-2209

Alaska Area

Alaska Area Director
Fish & Wildlife Service
Interior Department
1011 E. Tudor Road
Anchorage, AK 99503

(907) 276-3800

APPENDIX D-4

NATIONAL PARK SERVICE,
U.S. DEPARTMENT OF INTERIOR,
NATIONAL AND REGIONAL OFFICES

National Capital Office

Director
National Park Service
1100 Ohio Dr. S. W.
Washington, DC 20242

202 426-6612

North Atlantic Office

Director
National Park Service
15 State Street
Boston, MA 02109

617 223-3769

Mid Atlantic Office

Director
National Park Service
143 South 3rd St.
Philadelphia, PA 19106

215 597-7013

Southeast Office

Director
National Park Service
75 Spring St., S. W.
Atlanta, GA 30344

404 221-5185

Midwest Office

Director
National Park Service
1709 Jackson St.
Omaha, NE 68102

402 221-3431

Rocky Mountain Office

Director
National Park Service
P.O. Box 25287
Denver, CO 80225

303 234-2500

Southwest Office

Director
National Park Service
P. O. Box 728
Santa Fe, NM 87501

505 988-6388

Western Office

Director
National Park Service
450 Golden Gate Ave.
San Francisco, CA 94102

415 556-4196

Pacific Northwest Office

Director
National Park Service
1920 Westin Bldg.
2001 Sixth Ave
Seattle, WA 98121

206 442-5565

Alaska

Director
National Park Service
540 West Fifth Ave.
Room 202
Anchorage, AK 99501

907 276-8166

APPENDIX D-5

FOREST SERVICE,
U.S. DEPARTMENT OF AGRICULTURE,
AND
BUREAU OF LAND MANAGEMENT,
U.S. DEPARTMENT OF INTERIOR,
NATIONAL AND REGIONAL OFFICES

LOCATION OF FOREST SERVICE OFFICES

Alaska Region

P.O. Box 1628
Federal Office Building
Juneau, AK 99802

(907) 586-7263

Eastern Region

National Forest System
633 West Wisconsin Avenue
Milwaukee, WI 53202

(414) 291-3693

Intermountain Region

324 25th Street
Ogden, UT 84401

(801) 626-3176

Pacific Southwest Region

630 Sansome Street
San Francisco, CA 94111

(415) 556-1932

Rocky Mountain Region

11177 W. 8th Avenue
P.O. Box 25127
Lakewood, CO 80225

(303) 234-4187

Southeastern Area

State and Private Forestry
1720 Peachtree Road, NW
Atlanta, GA 30309

(404) 881-4191

Northeastern Area

State and Private Forestry
370 Reed Street
Broomall, PA 19008

(215) 461-1600

Northern Region

Federal Building
Missoula, MT 59807

(406) 329-3011

Pacific Northwest Region

P.O. Box 3623
319 SW. Pine Street
Portland, OR 97204

(503) 221-3625

Southern Region

National Forest System
1720 Peachtree Rd., NW
Atlanta, GA 30309

(404) 881-4191

Southwestern Region

517 Gold Avenue, SW
Albuquerque, NM 87102

(505) 766-2444

LOCATION OF BLM FIELD OFFICES

Alaska

State Director
Bureau of Land Management
Interior Department
701 C Street
Box 13
Anchorage, AK 99513

(907) 271-5076

Arizona

State Director
Bureau of Land Management
Interior Department
2400 Valley Bank Center
Phoenix, AZ 85073

(602) 261-3873

California

State Director
Bureau of Land Management
Interior Department
Federal Office Bldg.
Room E-2841
2800 Cottage Way
Sacramento, CA 95825

(916) 484-4676

Colorado

State Director
Bureau of Land Management
Interior Department
Rm 700 Colorado Bank Bldg.
1600 Broadway
Denver, CO 80202

(303) 837-4325

Eastern States

Director
Eastern States Office
Bureau of Land Management
Interior Department
350 South Pickett Street
Alexandria, VA 22304

(703) 235-2833

Idaho

State Director
Bureau of Land Management
Interior Department
Room 398 Federal Building
550 West Fort Street
P.O. Box 042
Boise, ID 83724

(208) 385-1401

Montana*

State Director
Bureau of Land Management
Interior Department
222 N. 32nd Street
P.O. Box 30157
Billings, MT 59107
* Serves ND, SD, & MN

(406) 657-6461

Nevada

State Director
Bureau of Land Management
Interior Department
Rm. 3008 Federal Bldg.
300 Booth Street
Reno, NV 89509

(702) 784-5451

New Mexico*

State Director
Bureau of Land Management
Interior Department
Post Office and Fed. Bldg.
South Federal Plaza
P.O. Box 1449
Santa Fe, NM 87501
* Serves Oklahoma and some
mineral interests only in Texas

(505) 231-6251

Utah

State Director
Bureau of Land Management
Interior Department
University Club Bldg.
136 East South Temple
Salt Lake City, UT 84111

(801) 524-5311

Wyoming

State Director
Bureau of Land Management
Interior Department
2515 Warren Avenue
P.O. Box 1828
Cheyenne, Wy 82001

(307) 778-2220

APPENDIX D-6

BUREAU OF RECLAMATION,
U.S. DEPARTMENT OF INTERIOR,
NATIONAL AND REGIONAL OFFICES

Office of the Commissioner
Bureau of Reclamation
Department of the Interior
Washington, D. C. 20240

(202) 343-4157

Pacific Northwest

Director
Pacific Northwest Region
Bureau of Reclamation
Interior Department
Federal Building
550 West Fort Street
Boise, ID 83724

(208) 384-1908

Mid-Pacific

Director
Mid-Pacific Basin
Bureau of Reclamation
Interior Department
Federal Office Building
2800 Cottage Way
Sacramento, CA 95825

(916) 484-4571

Lower Colorado

Director
Lower Colorado Region
Bureau of Reclamation
Interior Department
Nevada Hwy. & Park Street
P.O. Box 427
Boulder City, NV 89005

(406) 657-6214

Upper Colorado

Director
Upper Colorado Region
Bureau of Reclamation
Interior Department
125 South State Street
P.O. Box 11568
Salt Lake City, UT 84147

(801) 524-5592

Southwest

Director
Southwest Region
Bureau of Reclamation
Interior Department
Commerce Building, Suite 201
714 South Tyler Street
Amarillo, TX 79101

(806) 378-5445

Upper Missouri

Director
Upper Missouri Region
Bureau of Reclamation
Interior Department
Federal Office Building
316 North 26th Street
P.O. Box 2553
Billings, MT 59103

(702) 293-8411

Lower Missouri

Director
Lower Missouri Region
Bureau of Reclamation
Interior Department
Building 20
Denver Federal Center
Denver, CO 80225

(303) 234-4441

Engineering & Research

Engineering & Research Center
Bureau of Reclamation
Interior Department
Building 67
Denver Federal Center
Denver, CO 80225

(303) 234-2041

APPENDIX D-7

FEDERAL MARKETING ENTITIES
ADDRESSES OF ADMINISTRATIVE OFFICES

Alaska Power Administration
Federal Building
P.O. Box 50
Juneau, AK 99802

Bonneville Power Administration
1002 N.E. Holliday St.
Portland, OR 97208

Southeastern Power Administration
Elberton, GA 30635

Western Area Power Administration
P.O. Box 3403
Golden, CO 80401

Southwestern Power Administration
Page Belcher Federal Building
Tulsa, OK 74101

Tennessee Valley Authority
400 Commerce Ave.
Knoxville, TN 37902

APPENDIX E

ADDRESSES OF STATE AGENCIES

E-1	State Agencies Responsible for Water Resources and Water Rights	E1-i
E-2	State Agencies Responsible for Public Electric Utility Regulation	E2-i
E-3	State Agencies Responsible for Administration of State-Owned Land and Land Laws	E3-i
E-4	State Agencies Responsible for Water Quality Standards	E4-i
E-5	State Agencies Responsible for Fish and Wildlife Regulation and Management	E5-i
E-6	State Agencies Responsible for Environmental Impact Compliance	E6-i
E-7	State Agencies Responsible for Archeological and Historic Preservation	E7-i
E-8	State Agencies Responsible for Energy Conservation and Renewable Energy Development	E8-i
E-9	State Agencies Responsible for Natural Resources	E9-i

APPENDIX E-1

STATE AGENCIES RESPONSIBLE FOR
WATER RESOURCES AND WATER RIGHTS

ALABAMA

James J. Plaster, Exec. Secy
Water Resources Unit
1445 Federal Dr.
P.O. Box 3336
Montgomery, AL 36193
(205)832-3727

ALASKA

Theodore G. Smith, Dir.
Div. of Forest, Land & Water Mgt.
Dept. of Natural Resources
323 E. Fourth Ave.
Anchorage, AK 99501
(907)279-577

AMERICAN SAMOA

Marty Heath, Dir.
Water Task Force
Dept. of Public Works
Utulei
Pago Pago, AS 96799
633-4116

ARIZONA

Wesley E. Steiner, Exec. Dir.
Water Comm.
222 N. Central Ave. #800
Phoenix, AZ 85004
(602)258-7561

ARKANSAS

John P. Saxton, Dir.
Soil & Water Conservation Comm.
Dept. of Commerce
1818 W. Capitol Ave.
Little Rock, AR 72202
(501)371-1611

CALIFORNIA

Ronald B. Robie, Dir.
Dept. of Water Resources
1416 Ninth St.
Sacramento, CA 95814
(916)445-6582

COLORADO

Gary Broetzman, Dir.
Water Quality Control &
Public Health Engineering
4210 E. 11th Ave.
Denver, CO 80203
(303)320-8333

CONNECTICUT

Benjamin Warner, Dir.
Soil & Water Conserv.
Dept. of Envir. Protection
165 Washington St., Rm 207
Hartford, CT 06715
(203)566-7220

DELAWARE

Laurence R. Ireland, Dir.
Div. of Soil & Water Conser.
Nat. Res. & Envir. Control
Tatnall Bldg.
Dover, DE 19901
(302)736-4411

FLORIDA

Al Bishop, Actg. Chf.
Bur. of Water Management
Dept. of Envir. Regulation
2600 Blair Stone Rd.
Tallahassee, FL 32301
(904)488-9560

GEORGIA

Chris White, Prog. Mgr.
Dept. of Natural Resources
270 Washington St., SW
Atlanta, GA 30334
(404)656-3094

GUAM

Antonio Megofna, Chf. Offr.
Public Utility Agcy.
P.O. Box 3010
Agana, GU 97910
(671)646-8891

HAWAII

Robert T. Chuck, Mgr./Chf. Engr.
Water & Land Development
Dept. of Land & Natural Res.
1151 Punchbowl St.
Honolulu, HT 96813
(808)548-7539

IDAHO

A. Kenneth Dunn, Dir.
Dept. of Water Resources
450 W. State St.
Boise, ID 83720
(208)334-4437

ILLINOIS

Frank Kudrna, Dir.
Div. of Water Resources
Dept. of Transportation
300 DOT Administration Bldg.
Springfield, IL 62764
(217)782-2152

INDIANA

Robert F. Jackson, Dir.
Div. of Water
Dept. of Natural Resources
State Office Bldg., Rm. 605
Indianapolis, IN 46204
(317)23204160

IOWA

James R. Webb, Dir.
Natural Resources Contil
Wallace Bldg.
Des Moines, IA 50319
(515)281-5913

KANSAS

(Vacancy), Dir.
Office of Kansas Water
503 Kansas Ave.
Topeka, KS 6603
(913)296-3185

KENTUCKY

John Smither, Actg. Dir.
Div. of Water Quality
Nat. Resources & Envir. Prot.
18 Reilly Rd., Ft. Boone Plaza
Frankfort, KY 50601
(502)564-3410

LOUISIANA

Irvin F. Hingle, Asst. Secy.
Office of Public Works
Dept. of Trans. & Dev.
P.O. Box 44245
Baton Rouge, LA 70804
(504)342-7534

MAINE

Frank W. Ricker, Exec. Dir.
Soil & Water Conservation Comm.
Dept. of Ag., Food & Rural Res.
State House, Station #28
Augusta, ME 04333
(207)289-2666

MARYLAND

Thomas C. Andrews, Dir.
Water Resources Admin.
Dept. of Natural Resources
Tawes State Off. Bldg.
Annapolis, MD 21401
(301)269-3846

MASSACHUSETTS

Charles F. Kennedy, Dir.
Div. of Water Resources
Exec. Off. of Envir. Aff.
100 Cambridge St., Rm 1900
Boston, MA 02202
(617)727-3267

MICHIGAN

Robert J. Courchaine, Chf.
Div. of Water Quality
Mason Bldg., 8th Fl.
P.O. Box 30028
Lansing, MI 48909
(517)373-1947

L. N. Witta, Chf.
Div. of Water Management
Mason Gldg., 5th Fl.
P.O. Box 30028
Lansing, MI 48909
(517)373-3930

MINNESOTA

Thomas Kalitowski, Chmn.
Water Plan Bd.
600 American Center Bldg.
150 E. Kellogg Blvd.
St. Paul, MN 55101
(612)296-1424

MISSISSIPPI

Charles Chisolm, Dir.
Bur. of Pollution Control
Dept. of Natural Resources
2380 Hwy. 80 W.
Jackson, MS 39209
(601)961-5171

MISSOURI

Rober L. Dunkeson, Prog. Dir.
Water Resources Planning Prog.
Dept. of Natural Resources
P.O. Box 1368
Jefferson City, MO 65102
(314)751-3241

MONTANA

Gary Fritz, Administr.
Div. of Water Resources
Natural Resources & Conser.
32 S. Ewing
Helena, MT 59620
(406)4449-2872

NEBRASKA

J. Michael Jess, Dir.
Dept. of Water Resources
301 Centennial Mall, S.
Lincoln, NE 68509
(402)471-2363

NEVADA

Peter Morros, Engr.
Div. of Water Resources
Dept. of Conserv. & Nat. Res.
201 S. Fall St.
Carson City, NV 89710
(702)885-4360

NEW HAMPSHIRE

George M. McGee, Sr., Chmn.
Water Resources Bd.
37 Pleasant St.
Concord, NH 03301
(703)271-3406

NEW JERSEY

Arnold Schiffman, Dir.
Div. of Water Resources
Dept. of Environmental Prot.
CN-029
Trenton, NJ 08625
(609)292-1637

NEW MEXICO

Steve E. Reynolds, State Engr.
Div. of Water Resources
Dept. of Natural Resources
Bataan Memorial Bldg.
Santa Fe, NM 87503
(505)827-2127

NEW YORK

Russel Mt. Pleasant, Assoc. Dir.
Div. of Water
Dept. of Envir. Conserv.
50 Wolf Rd., Rm. 306
Albany, NY 12233
(518)457-6674

NORTH CAROLINA

John Morris, Dir.
Office of Water Resources
Natural Res. & Community Dev.
512 N. Salisbury St.
Raleigh, NC 27611
(919)733-4064

NORTH DAKOTA

Vern Fahy, State Engr.
Water Commission
State Office Bldg.
900 East Blvd.
Bismarck, ND 58505
(701)224-4940

OHIO

John H. Cousins, Chf.
Div. of Water
Dept. of Natural Resources
Fountain Square
Columbus, OH 43224
(614)466-4768

OKLAHOMA

Jim Barnett, Exec. Dir.
Water Resources Ed.
1000 NE 10th, 12th Fl.
Oklahoma City, OK 63152
(405)271-2555

OREGON

Daniel Kennedy, Adminstr.
Dept. of Water Resources
555 13th St., NE
Salem, OR 97310
(503)378-3741

PENNSYLVANIA

Walter N. Peechatka, Dir.
Bur. of Soil & Water Conserv.
Dept. of Environmental Res.
114 Evangelical Press Bldg.
Harrisburg, PA 17120
(717)787-5267

PUERTO RICO

Carl Axel P. Soderberg, Dir.
Environmental Quality Bd.
Div. of Water
P.O. Box 11488
Santurce, PR 00910
(809)725-5140

RHODE ISLAND

Robert Russ, Exec. dir.
Water Resources Bd.
265 melrose St.
Providence, RI 02907
(401)277-2217

SOUTH CAROLINA

Clair P. Guess, Jr., Exec. Dir.
Water Resources Comm.
3830 Forest Dr:
P.O. Box 4515
Columbia, SC 29204
(803)758-2514

SOUTH DAKOTA

Warren Neufeld, Secy.
Dept. of Water & Nat. Resources
Foss Bldg., 2nd Fl.
Pierre, SD 56501
(705)773-3151

TENNESSEE

Robert Hunt, Dir.
Div. of Water Resources
Dept. of Conservation
4721 Trousdale Dr.
Nashville, TN 36211
(615)741-6860

TEXAS

Harvey Davis, Exec. Dir.
Dept. of Water Resources
P.O. Box 13087
Austin, TX 78711

UTAH

Daniel F. Lawrence, Dir.
Div. of Water Resources
Dept. of Natural Resources
231 E. Fourth S.
Salt Lake City, UT 84111
(801)533-5401

VERMONT

John Ponsetto, Comr.
Dept. of Water Resources
Agcy. of Environmental Conserv.
79 River St.
Montpelier, VT 05602
(802)828-3361

VIRGINIA

R. V. Davis, Exec. Secy.
Water Control Bd.
211 N. Hamilton St.
Richmond, VA 23230
(804)257-6384

WASHINGTON

Glen H. Fiedler, Asst. Dir.
Office of Water Programs
Dept. of Ecology
St. Martins College
Olympia, WA 98504
(206)753-3893

WEST VIRGINIA

David W. Robinson, Chf.
Div. of Water Resources
Dept. of Natural Resources
1201 Greenbrier St.
Charleston, WV 25305

WYOMING

Michael Reese, Adminstr.
Water Development Comm.
Barrett Bldg.
Cheyenne, WY 82001
(306)777-7262

APPENDIX E-2

ADDRESSES OF STATE AGENCIES RESPONSIBLE FOR
PUBLIC ELECTRIC UTILITY REGULATION

ALABAMA

Billy Joe Camp, Pres.
Public Service Comm.
State Office Bldg.
Montgomery, AL 36130
(205)832-5801

ALASKA

Carolyn S. Guess, Commr.
Public Utilities Com.
Dept. of Commerce & Econ. Dev.
338 Denali St.
Anchorage, AK 99501
(907)276-6222

ARIZONA

Neill T. Dimmick, Dir.
Div. of Utilities
Corporation Comm.
1210 W. Washington St.
Phoenix, AZ 85006
(702)25504251

ARKANSAS

Nathan M. Norton, Jr., Chmn.
Public Service Comm.
Dept. of Commerce
400 Union Station
Little Rock, AR 72201
(501)371-1453

CALIFORNIA

John E. Bryson, Pres.
Public Utilities Comm.
350 McAllister St.
San Francisco, CA 94102
(415)556-3703

COLORADO

Harry Galligan, Chmn.
Public Utilities Comm.
Dept. of Regulatory Agencies
State Services Bldg., 5th Fl.
Denver, CO 80203

CONNECTICUT

Thomas H. Fitzpatrick, Chmn.
Public Utilities Control Auth.
Dept. of Public Utility Control
165 Capitol Ave., Rm 573
Hartford, CT 06115
(203)566-7380

DELAWARE

Robert J. Kennedy, Dir.
Public Utilities Control
Dept. of Administrative Ser.
1560 S. du Pont Hwy.
Dover, DE 19901
(302)736-4247

FLORIDA

David L. Swafford, Exec. Dir.
Public Service Comm.
101 E. Gaines St.
Tallahassee, FL 32301
(904)488-7181

GEORGIA

Ford B. Spinks, Chmn.
Public Service Comm.
244 Washington St., Rm. 162
Atlanta, GA 30334
(404)656-4501

GUAM

Galo E. Camacho, Chmn.
Public Utilities Comm.
173 W. Aspiunall Ave.
Agana, GU 96910
(671)477-7220

HAWAII

Albert Q. Y. Tom, Chmn.
Public Utilities Comm.
472 W. Washington St.
Boise, ID 83720
(208)334-3143
(303)866-3154

ILLINOIS

Michael V. Hasten, Chmn.
Commerce Comm.
527 E. Capitol Ave.
Springfield, IL 62706
(216)782-5778

INDIANA

Larry Wallace, Chmn.
Public Service Comm.
State Office Bldg., Rm. 901
Indianapolis, IN 46204
(317)232-2704

IOWA

Andrew Varley, Chmn.
Commerce Comm.
Lucas Bldg.
Des Moines, IA 50319
(515)281-5167

KANSAS

Richard C. Loux, Chmn.
Corporation Comm.
State Office Bldg.
Topeka, KS 66612
(913)296-3323

KENTUCKY

Marlin Volz, Chmn.
Public Service Comm.
730 Schenkel Ln., P.O. Box 615
Frankfort, KY 40601
(502)564-3940

LOUISIANA

Ed Kennon, Chmn.
Public Service Comm.
1630 One American Place
Baton Rouge, LA 70825
(504)342-4404

MAINE

Ralph Gelder, Chmn.
Public Utilities Comm.
State House, Station #18
Augusta, ME 0433
(207)289-3831

MARYLAND

Thomas J. Hatem, Chmn.
Utility Consumer Advisory Panel
Pub. Ser. Comm., American Bldg.
231 E. Baltimore St.
Baltimore, MD 21202
(301)659-6000

MASSACHUSETTS

Doris Pote, Chpn.
Dept. of Public Utilities
Exec. Office of Consumer Aff.
100 Cambridge St.
Boston, MA 02202
(617)727-3503

MICHIGAN

Daniel J. Demlow, Chmn.
Public Service Comm.
Dept. of Commerce
6545 Mercantile Way
Lansing, MI 48909
(517)373-3240

MINNESOTA

Randall Young, Exec. Secy.
Public Service Comm.
Dept. of Public Service
160 E. Kellogg Blve.
St. Paul, MN 55101
(612)354-7474

MISSOURI

Charles J. Fraas, Jr., Chmn.
Public Service Comm.
Jefferson Bldg.
P.O. Box 360
Jefferson City, MO 65102
(314)751-3243

MONTANA

Gordon Bollinger, Chmn.
Public Service Comm.
1227 11th Ave.
Helena, MT 59620
(506)449-3017

NEBRASKA

Terrence L. Kubicek, Exec. Secy.
Public Service Comm.
301 Centennial Mall, S.
Lincoln, NE 68509.
(402)471-3101

NEVADA

Roger C. Bos, Chmn.
Public Service Comm.
505 E. King St., Rm. 304
Carson City, NV 89710
(702)885-4180

NEW HAMPSHIRE

Michael Love, Chmn.
Public Utilities Comm.
Eight Old Suncook St.
Concord, NH 03301
(603)271-2452

NEW JERSEY

George H. Barbour, Pres.
Bd. of Public Utilities
101 Commerce St.
Newark, NJ 07102
(201)648-3733

NEW MEXICO

Richard P. Montoya, Chmn.
Public Service Comm.
Bataan Memorial Bldg.
Santa Fe, NM 87503
(505)827-2827

NEW YORK

Paul L. Gioia, Chmn.
Public Service Comm.
Empire State Plaza, Agcy. Bldg. 3
Albany, NY 12223
(518)474-2530

NORTH CAROLINA

Robert Koger, Chmn.
Utilities Commission
Dept. of Commerce
430 N. Salisbury St.
Raleigh, NC 27611

NORTH DAKOTA

Richard Elkin, Pres.
Public Service Commission
State Capitol, 12th Fl.
Bismarck, ND 58505
(701)224-2400

N. MARIANA ISLANDS

Pedro Sasamoto, Dir.
Public Works
Saipan, CM 97950
Overseas 9407

OHIO

William S. Newcomb, Jr., Chmn.
Public Utilities Comm.
375 S. High St.
Columbus, OH 43215
(614)466-3905

OKLAHOMA

Lamp Baker, Chmn.
Corporation Comm.
Jim Thorpe Bldg.
Oklahoma City, OK 73105
(405)521-2267

OREGON

John Lobdell, Commr.
Public Utility Commission
Labor & Industries Bldg.
Salem, OR 97310
(503)378-6611

PENNSYLVANIA

Susan M. Shanaman, Chpn.
Public Utility Comm.
North Office Bldg., Rm 104
Harrisburg, PA 17120
(717)787-5207

PUERTO RICO

Luis Berrios Amadeo, Pres.
Public Service Comm.
P.O. Box S-952
Old San Juan, PR 00902
(809)722-0450

RHODE ISLAND

Edward F. Burke, Chmn.
Public Utility Comm.
Dept. of Business Regulation
100 Orange St.
Providence, RI 02903
(401)277-3500

SOUTH CAROLINA

Rudolph Mitchell, Chmn.
Public Service Comm.
111 Doctor's Circle
Columbia, SC 29203
(803)758-3645

SOUTH DAKOTA

Patricia de Hueck, Exec. Secy.
Public Utilities Comm.
Dept. of Commerce
Capitol Bldg., 1st Fl.
Pierre, SD 56501
(605)741-2904

TEXAS

John E. Cunningham, Dir.
Public Utilities Comm.
78-- Shoal Creek Blvd.
Austin, TX 78757
(512)458-0100

UTAH

Milly O. Bernard, Chmn.
Public Service Comm.
Dept. of Business Regulation
330 E. Fourth South
Salt Lake City, UT 84111
(801)533-5518

VERMONT

Louise McCarren, Chpn.
Public Service Bd.
State Office Bldg.
Montpelier, VT 05602
(802)828-2321

VIRGINIA

Thomas P. Harwood, Jr., Commr.
State Corporation Comm.
Jefferson Bldg.
Richmond, VA 23219
(804)786-3603

VIRGIN ISLANDS

Arnold Golden, Commr.
Dept. of Public Works
P.O. Box H, Christiansted
St. Croix, VI 00820
(809)773-1789

WASHINGTON

Robert W. Bratton, Chmn.
Utilities & Transportation Comm.
Highways-Licenses Bldg.
Olympia, WA 98504
(206)753-6430

WEST VIRGINIA

E. Dandridge McDonald, Chmn.
Public Service Comm.
State Capitol, Rm. E-228
Charleston, WV 25305
(304)348-2164

WISCONSIN

Stanley York, Chmn.
Public Service Comm.
468 Hill Farms State Off. Bldg.
Madison, WI 53702
(608)266-1242

WYOMING

John R. Smythe, Commr.
Public Service Comm.
Capitol Hill Bldg.
Cheyenne, WY 82001
(307)777-7427

APPENDIX E-3

ADDRESSES OF STATE AGENCIES RESPONSIBLE FOR
ADMINISTRATION OF STATE-OWNED LAND AND LAND LAWS

ALABAMA

Edward N. Reynolds, Dir.
Div. of Lands
Administration Bldg.
Montgomery, AL 36130
(205)832-6323

ALASKA

John Katz, commr.
Dept. of Natural Resources
Pouch M
Juneau, AK 99811
(907)465-2400

AMERICAN SAMOA

Tito Malae, Contracting Offr.
Office of Material Management
Fagatogo
Pago Pago, AS 96799
633-5131

ARIZONA

Joseph T. Fallini, Comr.
Dept. of Lands
1624 W. Adams
Phoenix, AZ 85007
(602)255-2621

ARKANSAS

Bill McCuen, Land Comr.
Dept. of Lands
State Capitol
Little Rock, AR 72201
(501)372-1896

CALIFORNIA

William Northrop, Exec. Offr.
State Lands Comm.
1807 13th St.
Sacramento, CA 95814
(916)322-4105

COLORADO

Rowena Rogers, Pres.
Bd. of Land Comr.
Dept. of Natural Resources
Centennial Bldg., 6th Fl.
Denver, CO 80203
(303)866-3454

CONNECTICUT

Richard Wallace, Chf.
Land Acquisition & Management
Dept. of Envir. Protection
165 Capitol Ave., Rm 102
Hartford, CT 06115
(203)566-2904

FLORIDA

Richard P. Ludington, Dir.
Div. of State Lands
Dept. of Natural Resources
3900 Commonwealth Ave.
Tallahassee, FL 32303
(904)488-2725

GEORGIA

G. W. Hogan, Exec. Dir.
State Properties Comm.
7 Martin Luther King Jr. Dr., SW
Atlanta, GA 30334
(404)656-5602

GUAM

Dometro R. Pablo, Dir.
Dept. of Land Management
P.O. Bos 2950
Agana, GU 96910
(671)472-8851

HAWAII

Susumu Ono, Chmn.
Bd. of Land & Natural Res.
Dept. of Land & Natural Res.
1151 Punchbowl St.
Honolulu, HI 96813
(808)548-6550

IDAHO

Gordon C. Trombley, Dir.
Dept. of Lands
State Capitol, Rm. 121
Boise, ID 83720
(208)334-3284

ILLINOIS

Ray Norbut, Div. Head
Div. of Public Lands
Dept. of Conservation
605 Stratton Bldg.
Springfield, IL 62706
(217)782-1395

INDIANA

Orval Lundy, Actg. Comr.
Dept. of Administration
State Off. Bldg., Rm. 507
Indianapolis, IN 46204
(317)232-05535

IOWA

John Stokes, Chf.
Div. of Lands & Water
Conservation Comm.
Wallace Bldg.
Des Moines, IA 50319
(515)281-5207

KANSAS

Jack H. Brier, Secy of State
State House
Topeka, KA 66612
(913)296-2236

KENTUCKY

Clark Beauchamp, Commr.
Office of Facilities Mgt.
Dept. of Finance
Capitol Annex
Frankfort, KY 404601
(502)564-3590

LOUISIANA

Frank Ashby, Jr., Secy.
Dept. of Natural Resources
P.O. Box 44396
Baton Rouge, LA 70804
(504)342-4503

MAINE

Lloyd C. Irland, Dir.
Bur. of Public Lands
Dept. of Conservation
State House, Station #22
Augusta, ME 0433
(207)289-3061

MARYLAND

Donald E. MacLauchlin, Dir.
Forest & Park Ser.
Dept. of Natural Resources
Tawes State Off. Bldg.
Annapolis, MD 21401
(301)269-3775

MICHIGAN

Roland Harmes, Actg. Chf.
Div. of Lands
Mason Bldg., 5th Fl.
P.O. Box 30028
Lansing, MI 48909
(517)373-1246

MISSISSIPPI

Edwin L. Pittman, Secy. of State
401 Mississippi St.
Jackson, MS 39201
(601)354-6541

MISSOURI

Walter H. Johnson, Dir.
Div. of Design & Construction
Off. of Administration
P.O. Box 809
Jefferson City, MO 65102
(314)751-4174

MONTANA

Gareth C. Moon, Comr.
Dept. of Lands
1625 11th Ave.
Helena, MT 59620
(406)449-2074

NEBRASKA

Hyle E. Erwin, Exec. Secy.
Bd. of Educ. Lands & Funds
P.O. Box 94986
Lincoln, NE 68509
(402)471-2014

NEVADA

Jac R. Shaw, Administr.
Div. of State Lands
Dept. of Conser. & Nat. Res.
201 S. Fall St.
Carson City, NV 89710
(702)885-4363

NEW HAMPSHIRE

Theodore Natti, Dir.
Div. of Forest & Lands
Dept. of Resources & Econ. Dev
Sic Loudon Rd.
Concord, NH 03301
(603)271-2214

NEW JERSEY

Curt Hubert, Administr.
Green Acres & Outdoor Rec.
Dept. of Environmental Proc.
1301 Parkside Ave., Box 1420
Trenton, NJ 08625
(609)292-2454

NEW MEXICO

Alex Armijo, Commr.
Public Lands
Land Office Bldg., Rm. 102
P.O. Box 1148
Santa Fe, NM 87403
(505)827-2881

NEW YORK

Charles H. Jennings, Dir.
Div. of Land Utilization
Office of General Ser.
Empire State Plaza, Tower Bldg.
Albany, NY 12242
(518)474-4944

NORTH CAROLINA

Charlie Grady, Dir.
State Property
Dept. of Administration
116 W. Jones St.
Raleigh, NC 27611
(919)733-4346

NORTH DAKOTA

R.E. Lowmen, Commr.
Dept. of Lands
State Capitol, 6th Fl.
Bismarck, ND 58505

N. MARIANA ISLANDS

Antonio R. Sablan, Chmn.
Public Land Corporation
Saipan, CM 97950
Overseas 6914

OHIO

Mary Moss, Chf.
Office of Real Estate
Dept. of Natural Resources
Fountain Square
Columbus, OH 43224
(614)466-3074

Thomas R. Schroeder, Chf.
Bur. of Real Estate
Dept. of Administrative Ser.
30 E. Broad St.
Columbus, OH 43215
(714)466-4780

OKLAHOMA

William R. Massey, Secy.
Commissioners of the Land Off.
Jim Thorpe Bldg., 4th Fl.
Oklahoma City, OK 73105

OREGON

Ed Zajonc, Dir.
Div. of State Lands
1445 State St.
Salem, OR 97310
(503)376-3805

PENNSYLVANIA

Walter Baran, Secy.
Dept. of General Ser.
North Office Bldg., Rm. 515
Harrisburg, PA 17120
(717)787-5996

PUERTO RICO

Hipolito Vazquez Cabrera, Dir.
Land Authority
P.O. Box 9745
Santurce, PR 0908
(809)722-3070

RHODE ISLAND

William F. Ryan, Chf.
Div. of Parks & Recreation
Dept. of Environmental Mgt.
83 Park St.
Providence, RI 02903
(401)277-2632

SOUTH CAROLINA

R. Cecil Mills, Asst. Dir.
Div. of General Ser.
Budget & Control Bd.
300 Gervais St.
Columbia, SC 29201
(803)758-7252

SOUTH DAKOTA

John J. Gerken, Comr.
Dept. of School & Public Lands
Capitol Bldg., 2nd Fl.
Pierre, SD 57501
(605)773-3303

TEXAS

Bob Armstrong, Comr.
General Land Office
837 Stephen F. Austin Bldg.
Austin, TX 78701
(512)475-2071

UTAH

William E. Dinehart, Dir.
Div. of State Lands
Forestry & Fire Control
231 E. Fourth S.
Salt Lake City, UT 84111
(801)533-5381

WASHINGTON

Brian J. Boule, Comr.
Dept. of Natural Resources
Public Lands Bldg.
Olympia, WA 98504
(206)753-5317

WEST VIRGINIA

Fannie E. Marland, Exec. Secy.
Public Land Corporation
Dept. of Natural Resources
Capitol Complex #3, Rm. 713
Charleston, WV 25305
(304)348-2224

WISCONSIN

Stephen E. Gauger, Secy.
Trust Lands & Investments
Dept. of Justice
505 N. Segoe Rd.
Madison, WI 53702
(208)266-1370

WYOMING

Oscar Swan, Dir.
Public Lands Comm.
Pioneer Bldg.
Cheyenne, WY 82001
(306)777-7331

APPENDIX E-4

ADDRESSES OF STATE AGENCIES RESPONSIBLE FOR
WATER QUALITY STANDARDS

ALABAMA

James W. Warr, Dir.
Water Improvement Comm.
Dept. of Public Health
Public Health Ser. Bldg.
Montgomery, AL 36130
(205)277-3630

ALASKA

Steve Torok, Dir.
Envir. Quality Mgt. Div.
Dept. of Envir. Conservation
Pouch O
Juneau, AK 99811
(907)255-1152

AMERICAN SAMOA

Amituana'i Saifoloi, Dir.
Public Health
Dept. of Health
Fagaalu
Pago Pago, AS 96799
633-4116

ARKANSAS

Jim Shell, Chf.
Div. of Water Pollution Control
Pollution Control & Ecology
8001 National Dr.
Little Rock, AR 72209
(501)371-1701

CALIFORNIA

Michael S. Sloss, Chf.
Div. of Water Quality
Water Resources Control Bd.
2014 T. St., 2nd Fl.
Sacramento, CA 95814
(916)445-7971

COLORADO

Gary Broetzman, Dir.
Water Quality Control &
Public Health Engineering
4210 E. 11th Ave.
Denver, CO 80203
(303)320-8333

CONNECTICUT

Robert B. Moore, Dir.
Water Compliance Unit
Dept. of Envir. Protection
165 Capitol Ave.
Hartford, CT 06115
(203)566-3245

DELAWARE

Robert J. Touhey, Mgr.
Bur. of Water Quality
Dept. of Natural Resources
Tatnall Bldg.
Dover, DE 19901
(302)736-4761

FLORIDA

G. J. Thabaraj, Chf.
Bur. of Water Analysis
Dept. of Envir. Regulation
2600 Blair Stone Rd.
Tallahassee, FL 32301
(904)488-6221

GEORGIA

Gene B. Welsh, Chf.
Water Protection Section
Dept. of Natural Resources
270 Washington St.
Atlanta, GA 30334
(404)656-6593

GUAM

Ricardo C. Duenas, Adminstr.
Environmental Protection Agcy.
P.O. Box 2999
Agana, GU 96910
(671)646-8863

HAWAII

Melvin K. Koizumi, Dep. Dir.
Div. of Envir. & Health Ser.
1250 Punchbowl St.
Honolulu, HI 96813
(808)548-4139

IDAHO

Alfred E. Murrey, Chf.
Bur. of Water Quality
Department of Health & Welfare
450 W. State St.
Boise, ID 83720
(208)223-4250

ILLINOIS

Roger Kanerva, Actg. Mgr.
Div. of Water Pollution Control
Environmental Protection Agcy.
220 Churchill Rd.
Springfield, IL 62706
(217)782-1654

INDIANA

John Winters, Branch Chf.
Water Quality Branch
State Bd. of Health
1330 W. Michigan St., Rm 388
Indianapolis, IN 46202
(317)633-0719

IOWA

J. Edward Brown, Head
Chemicals & Water Quality
Dept. of Environmental Quality
Wallace Bldg.
Des Moines, IA 50319
(515)281-8693

KANSAS

Eugene Jensen, Dr.
Bur. of Water Quality
Dept. of Health & Envir.
Forbes Field, Bldg. 740
Topeka, KS 66620
(913)862-9360

LOUISIANA

B. Jim Porter, Asst. Secy.
Office of Envir. Aff.
Dept. of Natural Res.
P.O. Box 44066
Baton Rouge, LA 70804
(504)342-1265

MAINE

Henry E. Warren, Commr.
Dept. of Envir. Protection
State House, Station #17
Augusta, ME 04333
(207)289-2811

MARYLAND

W. H. Eichbaum, Asst. Secy.
Dept. of Health & Mental Hygiene
201 W. Preston St.
Baltimore, MD 21201
(301)383-7328

MASSACHUSETTS

Thomas McMahon, Dir.
Water Pollution
Envir. Quality Engineering
One Winter St.
Boston, MA 02108
(617)426-4463

MICHIGAN

Robert J. Courchaine, Chf.
Div. of Water Quality
Mason Bldg., 8th Fl.
P.O. Box 30028
Lansing, MI 58909
(517)373-1947

MINNESOTA

Barry C. Shade, Dir.
Div. of Water Quality
Pollution Control Agcy.
1935 W. County Rd., B-2
Roseville, MN 55113
(612)296-7354

MISSISSIPPI

Charles Chisolm, Dir.
Bur. of Pollution Control
Dept. of Natural Resources
2380 Hwy. 80 W.
Jackson, MS 39209
(601)961-5171

MISSOURI

Richard Rankin, Staff Dir.
Water Pollution Control Prog.
Dept. of Natural Resources
P.O. Box 1368
Jefferson City, MO 65102
(314)751-3241

MONTANA

Steven L. Pilcher, Chf.
Bur. of Water Quality
Health & Environmental Serv.
Cogswell Bldg., Rm A206
Helena, MT 59620
(406)49-2406

NEBRASKA

Robert Wall, Chf.
Water & Solid Waste Mgt.
Dept. of Envir. Control
301 Centennial Mall, S.
Lincoln, NE 68509
(402)471-2186

NEVADA

Lewis Dodgion
Div. of Environmental Prot.
Dept. of Conserv & Nat. Res.
201 S. Fall St.
Carson City, NV 89710
(702)885-4670

NEW HAMPSHIRE

William A. Healy, Exec. Dir.
Water Supply & Pollut. Control Comm.
Hazen Dr.
Concord, NH 03301
(603)271-3503

NEW JERSEY

Arnold Schiffman, Dir.
Div. of Water Resources
Dept. of Environmental Prot.
CN-029
Trenton, NJ 08625
(609)292-1637

NEW MEXICO

Thomas Baca, Dir.
Div. of Environment Improvement
Health & Environment Dept.
725 St. Michael's Dr.
Santa Fe, NM 87503
(505)827-5271

NEW YORK

Salvator Pagano, Asst. Dir.
Dept. of Environmental Conserv.
50 Wolf Rd., Rm 306
Albany, NY 12233
(518)457-2415

NORTH CAROLINA

Neil Grigg, Dir.
Environmental Management
Natural Res. Community Dev.
512 N. Salisbury St.
Raleigh, NC 27611
(919)733-4006

NORTH DAKOTA

Norman Peterson, Dir.
Water Supply & Pollut. Control
Dept. of Health
1200 Missouri Ave.
Bismarck, ND 58505
(701)224-2354

N. MARIANA ISLANDS

Gregory Tom, Coord.
Office of Water Quality
Planning & Budget Affairs Off.
Saipan, CM 97950
Overseas 7284

OHIO

Erna Rotering, Chf.
Office of Wastewater Pollution Control
361 E. Broad St.
Columbus, OH 53215
(614)466-7427

OKLAHOMA

Charles Newton, Chf.
Water Quality Service
Dept. of Health
1000 NE 10th, P.O. Box 53551
Oklahoma City, OK 73152
(405)271-5205

OREGON

Harold L. Sawyer, Administr.
Div. of Water Quality
522 SW Fifth Ave.
Portland, OR 97204
(503)229-5324

PENNSYLVANIA

Louis Bercheni, Dir.
Bur. of Water Quality Mgt.
Fulton Bldg., 11th Fl.
Harrisburg, PA 17120
(717)787-2666

PUERTO RICO

Pedro A. Gelabert, Exec. Dir.
Environmental Quality GBd.
P.O. Box 11488
Santurce, PR 00910
(809)725-5410

RHODE ISLAND

James Fester, Chf.
Div. of Water Resources
Dept. of Environmental Mgt.
75 Davis St.
Providence, RI 02908
(401)277-2217

SOUTH CAROLINA

John E. Jenkins, Dep. Commr.
Environmental Quality Control
2600 Bull St.
Columbia, SC 29201
(803)758-5450

SOUTH DAKOTA

Jim Nelson, Dir.
Div. of Envir. Health
Foss Bldg.
Pierre, SD 57501
(605)758-5450

TENNESSEE

D. Elmo Lunn, Dir.
Div. of Water Quality
621 Cordell Hull Bldg.
Nashville, TN 37219
(615)741-6610

TEXAS

Harvey Davis, Exec. Dir.
Dept. of Water Resources
P.O. Box 13087
Austin, TX 78711
(512)475-3187

UTAH

Cal Sudweeks, Dir.
Div. of Environmental Health
150 W. N. Temple, Rm. 410
Salt Lake City, UT 84103
(801)533-6146

VERMONT

David L. Clough, Dir.
Dept. of Water Resources
79 River St.
Montpelier, VT 0-5602
(802)828-2761

VIRGINIA

Eric H. Bartsch, Dir.
Div. of Water Programs
109 Governor St., 9th Fl.
Richmond, VA 23219
(804)786-1760

R. V. Davis, Exec. Secy.
Water Control Bd.
2111 N. Hamilton St.
Richmond, VA 23230
(804)257-6384

WASHINGTON

Glen H. Fiedler, Asst. Dir.
Office of Water Programs
Dept. of Ecology
St. Martins College
Olympia, WA 98504

WEST VIRGINIA

David W. Robinson, Chf.
Div. of Water Resources
Dept. of Natural Resources
1201 Greenbrier St.
Charleston, WV 25305
(304)348-2107

WISCONSIN

F. M. Schraufrel, Dir.
Bur. of Water Quality Mgt.
Dept. of Natural Resources
101 S. Webster St.
Madison, WI 53702
(608)267-7610

WYOMING

William Garland, Adminstr.
Water Quality
Environment Quality
1111 E. Lincoln Way
Cheyenne, WY 82001
(307)777-7781

APPENDIX E-5

ADDRESSES OF STATE AGENCIES RESPONSIBLE FOR
FISH AND WILDLIFE REGULATION AND MANAGEMENT

ALABAMA

John McMillian, Commr.
Dept. of Conser. & Natural Resources
Administration Bldg., Rm. 702
Montgomery, AL 36130
(205)832-6316

ALASKA

Ronald O. Skoog, Commr.
Dept. of Fish & Game
Support Bldg.
Juneau, AK 99801
(907)465-4100

ARIZONA

Roger Guenewald, Dep. Dir.
Dept. of Game & Fish
2222 W. Greeway Rd.
Phoenix, AZ 85023
(602)942-3000

ARKANSAS

Steve Wilson, Dir.
Game & Fish Comm.
Two Natural Resources Dr.
Little Rock, AR 62205
(501)223-6300

CALIFORNIA

E. Charles Fullerton, Dir.
Dept. of Fish & Game
1416 Ninth St., 12th Fl.
Sacramento, CA 95814
(916)445-3535

COLORADO

Jack Grieb, Dir.
Div. of Wildlife
Dept. of Natural Resources
6060 Broadway
Denver, CO 80216
(303)825-1192

CONNECTICUT

Robert Jones, Chf.
Fish & Waterlife
Dept. of Envir. Protection
165 Capitol Ave., Rm. 243
Hartford, CT 06115
(203)566-2287

DELAWARE

William Wagner, Dir.
Div. of Fish & Wildlife
Tatnall Bldg.
Dover, DE 19901
(302)736-4431

FLORIDA

Robert M. Brantly, Exec. Dir.
Game & Fresh Water Fish Comm.
620 Meridian St., Bryant Bldg.
Tallahassee, FL 32302
(904)488-2975

GEORGIA

Leon Kirkland, Dir.
Div. of Game & Fish
Dept. of Natural Resources
270 Washington St., SW
Atlanta, GA 30334
(404)656-3523

GUAM

Harry Kami, Chf.
Aquatic & Wildlife & Resources
Dept. of Agriculture
P.O. Box 23367
Agana, GU 979212
(671)734-9966

HAWAII

Kenji Ego, Dir.
Div. of Fish & Game
Dept. of Land & Natural Res.
1151 Punchbowl St.
Honolulu, HI 97813
(808)548-4000

IDAHO

Jerry M. Conley, Dir.
Dept. of Fish & Game
600 S. Walnut
Boise, ID 83706
(208)334-3771

ILLINOIS

Mike Conlim, Chf.
Div. of Fish & Wildlife Res.
Dept. of Conservation
605 Stratton Bldg.
Springfield, IL 62706
(217)783-6384

INDIANA

Edward Hansen, Dir.
Conservation Comm.
State Office Bldg., Rm. 607
Indianapolis, IN 46204
(317)232-4090

IOWA

Allan Farris, Chf.
Div. of Fish & Wildlife
Conservation Comm.
Wallace Bldg.
Des Moines, IA 50319
(515)281-5714

KANSAS

Bill Hanzlick, Dir.
Fish & Game Comm.
P.O. Box 54A, RR#2
Pratt, KS 672124
(316)672-5911

KENTUCKY

Carl E. Kays, Commr.
Office of the Commissioner
Dept. of Fish & Wildlife Res.
One Game Farm Rd.
Frankfort, KY 40601
(502)564-3400

LOUISIANA

Jesse J. Guidry, Secy.
Dept. of Wildlife & Fisheries
400 Royal St.
Baton Rouge, LA 70130
(504)568-5667

MAINE

Glenn H. Manuel, Commr.
Dept. of Inland Fisheries
& Wildlife
State House, Station #41
Augusta, ME 04333
(207)289-3371

MARYLAND

Bernard F. Halla, Dir.
Wildlife Administration
Div. of Fish & Wildlife
Dept. of Natural Resources
Tawes State Off. Bldg.
Annapolis, MD 21401
(301)269-3195

MASSACHUSETTS

Richard Cronin, Dir.
Div. of Fisheries & Wildlife
Recreational Vehs.
100 Cambridge St.
Boston, MA 02202
(617)727-3155

MICHIGAN

Robert Compeau, Actg. Bur. Chf.
Bur. of Resources
Mason Bldg, 6th Fl.
P.O. Box 30028
Lansing, MI 48909
(517)373-0046

MINNESOTA

(Vacancy), Dir.
Div. of Fish & Wildlife
Dept. of Natural Resources
Centennial Bldg., 3rd Fl.
St. Paul, MN 55155
(612)296-2894

MISSISSIPPI

Benny Herring, Dir.
Bur. of Fisheries & Wildlife
Dept. of Wildlife Conservation
P.O. Box 451
Jackson, MS 39205
(601)961-5300

MISSOURI

Larry R. Gale, Dir.
Dept. of Conservation
2901 N. Ten Mile Dr.
P.O. Box 18
Jefferson City, MO 65102
(314)751-4115

MONTANA

Jim W. Flynn, Dir.
Dept. of Fish, Wildlife & Parks
1420 E. Sixth Ave.
Helena, MT 59620
(406)449-3186

NEBRASKA

Ken Johnson, Dir.
Div. of Wildlife
Game & Parks Comm.
2200 N. 33rd St.
Lincoln, NE 68503
(402)464-0641

NEVADA

Joe Greenley, Dir.
Dept. of Wildlife
P.O. Box 10678
Reno, NV 89520
(702)784-6214

NEW HAMPSHIRE

Charles E. Barry, Exec. Dir.

Dept. of Fish & Game
34 Bridge St.
Concord, NH 03301
(603)271-3512

NEW JERSEY

Russell Cookingham, Dir.
Fish, Game & Wildlife
Dept. of Environmental Prot.
CN-400
Trenton, NJ 08625
(609)292-9410

NEW MEXICO

Harold F. Olson, Dir.
Dept. of Game & Fish
Villagra Bldg., 2nd Fl.
Santa Fe, NM 87503
(505)827-2923

NEW YORK

Kenneth F. Wich, Dir.
Div. of Fish & Wildlife
Dept. of Environmental Conser.
50 Wolf Rd.
Albany, NY 12233
(518)457-5690

NORTH CAROLINA

Vernon Beville, Exec. Dir.
Wildlife Resources Comm.
Natural Res. & Community Dev.
512 N. Salisbury St.
Raleigh, NC 27611
(919)733-3391

NORTH DAKOTA

Dale Henegar, Commr.
Dept. of Game & Fish
2121 Lovett Ave.
Bismarck, ND 58505
(701)224-2180

N. MARIANA ISLANDS

Joaquin Villagomez, Chf. of
Fisheries
Div. of Marine Resources
Natural Resources
Saipan, CM 97950
Overseas 9729

OHIO

Carl L. Mosley, Jr., Chf.
Div. of Wildlife
Dept. of Natural Resources
Fountain Square
Columbus, OH 53224
(614)466-7313

OKLAHOMA

Steven Lewis, Dir.
Dept. of Wildlife Conservation
1801 Lincoln Blvd.
Oklahoma City, OK 73105
(405)521-3851

OREGON

John R. Donaldson, Dir.
Dept. of Fish & Wildlife
506 SW Mill St.
Portland, OR 97201
(503)229-5406

PENNSYLVANIA

Ralph W. Abele, Exec. Dir.
Fish Comm.
3532 Walnut St.
P.O. Box 1673
Harrisburg, PA 17120
(717)787-3633

RHODE ISLAND

John M. Cronan, Chf.
Div. of Fish & Wildlife
Dept. of Environmental Mgt.
83 Park St.
Providence, RI 02903
(401)789-3094

SOUTH CAROLINA

James A Timmerman, Exec. Dir.
Dept. of Wildlife & Marine Res.
P.O. Box 167
Columbia, SC 29202
(802)758-0020

SOUTH DAKOTA

Jack Merwin, Secy.
Dept. of Game, Fish, & Parks
Anderson Bldg.
Pierre, SD 57501
(605)773-3387

TENNESSEE

Gary Myers, Exec. Dir.
Wildlife Resources Agcy.
P.O. Box 40747
Nashville, TN 37204
(615)741-1431

TEXAS

Charles D. Travis, Exec. Dir.
Dept. of Parks & Wildlife
4200 Smith School Rd.
Austin, TX 78744
(512)475-4801

UTAH

Douglas F. Day, Dir.
Div. of Wildlife Resources
Dept. of Energy & Natural Res.
1596 W. N. Temple
Salt Lake City, UT 84116
(801)533-9333

VERMONT

Edward F. Kehoe, Commr.
Dept. of Fish & Game
Agcy. of Environmental Conserv.
79 River St.
Montpelier, VT 05602
(802)828-3371

VIRGINIA

Richard H. Cross, Act. Dir.
Comm. on Game & Inland Fisheries
4010 W. Broad St.
Richmond, VA 23230
(804)257-1000

WASHINGTON

Frank R. Lock, Dir.
Dept. of Game
600 N. Capitol Way
Olympia, WA 98504
(206)753-6623

WEST VIRGINIA

Robert L. Miles, Chf.
Wildlife Resources
Dept. of Natural Resources
Capitol Complex Three, Rm. 812-A
Charleston, WV 25305
(304)348-2771

WISCONSIN

John M. Keener, Dir.
Bur. of Wildlife Management
Dept. of Natural Resources
101 S. Webster St.
Madison, WI 53702
(608)266-1877

WYOMING

Early Thomas, Dir.
Game & Fish Comm.
5400 Bishop Rd.
Cheyenne, WY 82001
(307)777-7631

APPENDIX E-6

ADDRESSES OF STATE AGENCIES RESPONSIBLE FOR
ENVIRONMENTAL IMPACT COMPLIANCE

ALABAMA

W. T. Willis, Dir.
Environmental Health Admin.
Dept. of Public Health
State Office Bldg., Rm. 328
Montgomery, AL 36130
(205)832-3176

ALASKA

Tom Hanna, Chf.
Air & Land Mgt. Section
Dept. of Environmental Conser.
Pouch O
Juneau, AK 99811
(907)465-2666

Ernst Mueller, Commr.
Dept. of Environmental Conser.
Pouch O
Juneau, AK 99811
(907)465-2600

AMERICAN SAMOA

Pati Fai'ai, Ecologist
Office of the Governor
Utulei
Pago Pago, AS 96799
633-4116

ARIZONA

James E. Sarn, Dir.
Dept. of Health Ser.
1740 W. Adams, Rm. 407
Phoenix, AZ 85006
(602)255-1024

ARKANSAS

Jarrell Southall, Dir.
Dept. of Pollution Control & Ecology
8001 National Dr.
Little Rock, AR 72209
(501)371-1701

CALIFORNIA

Mary D. Nichols, Secy.
Environmental Aff.
1102 Q St.
Sacramento, CA 95814
(916)322-5840
Community Dev.

Michael S. Sloss, chf.
Div. of Water Quality
Water Resources Control Bd.
2014 T St., 2nd Fl.
Sacramento, CA 95814
(916)445-7971

Terry A. Trumbull, Chmn.
Solid Waste Management Bd.
1020 Ninth St., Suite 300
Sacramento, CA 95814
(916)322-3330

COLORADO

Robert Arnott, Asst. Dir.
Office of Health Protection
Dept. of Health
4210 E. 11th Ave.
Denver, CO 80203
(303)320-8333

CONNECTICUT

Stanley J. Pac, Commr.
Dept. of Environmental Prot.
165 Capitol Ave., Rm. 117
Hartford, CT 06115
(203)566-2110

DELAWARE

John E. Wilson, Secy.
Dept. of Nat. Res.
& Envir. Control
Tatnall Bldg.
Dover, DE 19901
(302)736-4403

FLORIDA

Victoria Tschinkel, Secy.
Dept. of Environmental Reg.
2600 Blair Stone Rd.
Tallahassee, FL 32301
(904)488-4807

GEORGIA

J. Leonard Ledbetter, Dir.
Div. of Environmental Prot.
Dept. of Natural Resources
270 Washington St., SW
Atlanta, GA 30334
(404)656-4713

GUAM

Ricardo C. Duenas, Adminstr.
Environmental Prot. Agcy.
P.O. Box 2999
Agana, GU 96910
(671)646-8863

KANSAS

Jim Aikens, Dir.
Div. of Environment
Dept. of Health & Environment
Bldg. 740, Forbes Field
Topeka, KS 66620
(913)862-9360

KENTUCKY

Jackie Swigert, Secy.
Office of the Secretary
Nat. Res. & Envir. Prot.
Capital Plaza Tower
Frankfort, KY 40601
(502)564-3350

LOUISIANA

B. Jim Porter, Asst. Secy
Office of Environmental Aff.
Dept. of Natural Res.
P.O. Box 44066
Baton Rouge, LA 70804
(504)342-1265

MAINE

Henry E. Warren, Commr.
Dept. of Environmental Prot.
State House, Station #17
Augusta, ME 04333
(207)289-2811

MARYLAND

Thomas D. McKewen, Dir.
Environmental Ser.
Dept. of Natural Resources
60 West St.
Annapolis, MD 21401
(301)269-3351

MASSACHUSETTS

John A. Bewick, Secy.
Exec. Office of Envir. Aff.
100 Cambridge St., 20th Fl.
Boston, MA 02202
(617)727-9800

MICHIGAN

Gary Guenther, Bur. Chf.
Bur. of Environmental Prot.
P.O. Box 30028
Lansing, MI 48909
(517)373-7917

MINNESOTA

Louis Breimhurst, Dir.
Pollution Control Agcy.
1935 County Rd., B-2
Roseville, MN 55117
(612)296-7301

MISSISSIPPI

Charles Chisholm, Dir.
Bur. of Pollution Control
Dept. of Natural Resources
2380 Hwy. 80 W.
Jackson, MS 39209

MISSOURI

Robert Schreiber, Dir.
Div. of Environmental Quality
Dept. of Natural Resources
2010 Missouri Blvd.
Jefferson City, MO 65102
(314)751-3241

MONTANA

Donald G. Willems, Adminstr.
Div. of Environmental Sciences
Health & Environmental Sciences
Bd. of Health Bldg., 1st. Fl.
Helena, MT 59620
(406)449-3946

NEBRASKA

Dan T. Drain, Dir.
Dept. of Environmental Control
301 Centennial Mall, S.
Lincoln, NE 68509
(402)471-2186

NEVADA

Lewis Dodgion, Adminstr.
Div. of Environmental Prot.
Dept. of Conserv. & Nat. Res.
201 S. Fall St.
Carson City, NV 89610
(702)885-4670

NEW JERSEY

Jerry F. English, Commr.
Dept. of Environmental Prot.
CN-402
Trenton, NJ 08625
(609)292-2885

NEW MEXICO

Thomas Baca, Dir.
Div. of Environment Improvement
Dept. of Health & Environment
725 St. Michael's Dr.
Santa Fe, NM 87503
(505)827-5271

NORTH CAROLINA

Joseph W. Grimsley, Secy.
Dept. of Nat. Resources &
512 N. Salisbury St.
Raleigh, NC 27611
(919)733-4984

NORTH DAKOTA

Gene Christianson, Chf.
Environmental Control Section
Dept. of Health
1200 Missouri Ave.
Bismarck, ND 58505
(701)733-5984

N. MARIANA ISLANDS

George Chan, Chf. Planner
Office of Physical Planning
Office of Planning & Budget Aff.
Saipan, CM 96950
Overseas 7174

OHIO

Wayne Nichols, Dir.
Environmental Prot. Agcy.
361 E. Broad St.
Columbus, OH 53215
(614)466-8318

OKLAHOMA

Lawrence Edmison, Dir.
Dept. of Pollution Control
NE 10th & Stonewall
Oklahoma City, OK 73152
(405)271-4677

OREGON

William H. Young, Dir.
Dept. of Environment Quality
522 SW Fifth Ave.
Portland, OR 97204
(503)229-5395

PENNSYLVANIA

Peter Duncan, Actg. Secy.
Dept. of Environmental Res.
Fulton Bldg., 9th Fl.
Harrisburg, PA 17120
(717)787-2814

PUERTO RICO

Pedro A. Gelabert, Exec. Dir.
Environmental Quality Bd.
P.O. Box 11488
Santurce, PR 00910
(809)725-5410
(601)961-5171

RHODE ISLAND

W. Edward Wood, Dir.
Dept. of Environmental Mgt.
83 Park St.
Providence, RI 02903
(401)277-2771

SOUTH CAROLINA

John E. Jenkins, Dep. Commr.
Environmental Quality Control
Health & Environmental Control
2600 Bull St.
Columbia, SC 29201
(803)758-5450

SOUTH DAKOTA

Jim Nelson, Dir.
Div. of Environmental Health
Dept. of Water & Nat. Res.
Foss Bldg.
Pierre, SD 56501
(605)773-3151

TENNESSEE

Michael T. Bruner, Asst. Commr.
Environmental Health Services
Dept. of Public Health
150 Ninth Ave.
Nashville, TN 37203
(615)741-3657

UTAH

Alvin E. Rickers, Dir.
Div. of Environmental Health
Dept. of Health
150 W. N. Temple, Rm. 426
Salt Lake City, UT 84103
(801)533-6121

VERMONT

Brandan Whittaker, Secy.
Agcy. of Environmental Conserv.
79 River St.
Montpelier, VT 05602
(802)828-3130

VIRGINIA

J. B. Jackson, Jr., Administr.
Council on the Environment
Ninth St. Office Bldg.
Ninth & Grace Sts.
Richmond, VA 23219
(804)786-4500

WASHINGTON

Donald W. Moos, Dir.
Dept. of Ecology
St. Martins College
Lacey, WA 98504
(206)753-2240

WEST VIRGINIA

David C. Callaghan, Dir.
Dept. of Natural Res.
Capitol Complex #3, Rm. 669
Charleston, WV 25305
(304)348-3754

WISCONSIN

Thomas A. Kroehn, Adminstr.
Div. of Environmental Standards
Dept. of Natural Resources
101 S. Webster St., 5th Fl.
Madison, WI 53702
(608)266-1099

WYOMING

Rogert F. Sundin, Dir.
Environmental Quality
401 W. 19th
Cheyenne, WY 82001
(307)777-7937

APPENDIX E-7

ADDRESSES OF STATE AGENCIES RESPONSIBLE FOR
ARCHEOLOGICAL AND HISTORIC PRESERVATION

ALABAMA

Lawrence Oaks, Exec. Dir.
Historical Comm.
725 Monroe St.
Montgomery, AL 36130
(205)832-6621

ALASKA

Bill Hanable, Exec. Dir.
Historical Commission
Dept. of Education
3321 Providence Dr.
Anchorage, AK 99504
(906)274-6222

ARIZONA

Ann Pritzlaff, Preser. Offr.
State Parks, Bd.
1688 W. Adams, Rm. 122
Phoenix, AZ 85007
(602)255-4174

ARKANSAS

Wilson Stiles, Dir.
Historical Preservation Prog.
Dept. of Nat. & Cultural
Heritage
Continental Bldg., #410
Little Rock, AR 72201
(501)371-2763

CALIFORNIA

Knox Mellon, Hist. Preser. Offr.
Office of Historic Preservation
Dept. of Parks & Recreation
1200 K St.
Sacramento, CA 95814
(916)445-8066

COLORADO

Arthur C. Townsend, Exec. Dir.
Historical Society
Colorado Heritage Center
1300 Broadway
Denver, CO 80203
(303)866-3394

CONNECTICUT

John W. Shannahan, Dir.
Historical Comm.
59 S. Prospect St.
Hartford, CT 06106
(203)566-3005

FLORIDA

Randall Kelley, Dep. Secy. of State
Historic Preservation Bd.
Dept. of State
R. A. Gray Bldg.
Tallahassee, FL 32301
(904)487-4780

Lee Warner, Coord.
Historic Preservation Bd.
Dept. of State
R. A. Gray Bldg.
Tallahassee, FL 32301

GEORGIA

Henry D. Struble, Dir.
Div. of Parks, Rec. & Hist. Sites
270 Washington St., SW
Atlanta, GA 30334
(404)656-2754

GUAM

Joseph Soriano, Dir.
Dept. of Parks & Recreation
P.O. Box 2050
Agana, GU 96910
(671)472-9620

HAWAII

Richard Paglinawan, Chmn.
Hist. Places Review Bd.
Dept. of Land & Natural Res.
1151 Punchbowl St.
Honolulu, HI 97813
(808)548-4310

IDAHO

Arthur A. Hart, Dir.
Historical Society
Bd. of Education
610 N. Julia Davis Dr.
Boise, ID 83702
(208)334-2120

ILLINOIS

Chuck Tamminga, Assoc. Dir.
Land and Historic Sites
Dept. of Conservation
605 Stratton Bldg.
Springfield, IL 62706
(217)782-1394

INDIANA

Carl H. Armstrong, Dir.
Historic Preservation
Dept. of Natural Resources
202 N. Alabama
Indianapolis, IN 46204
(317)232-1637

IOWA

Adrian D. Anderson, Dir.
Div. of Hist. Museum & Arch.
Historical Dept.
Historical Bldg.
Des Moines, IA 50319
(515)281-3007

KANSAS

Richard Pankratz, Dir.
Dept. of Historic Preservation
State Historical Society
120 W. 10th St.
Topeka, KS 66612
(913)296-4788

KENTUCKY

William R. Buster, Dir.
Historical Society
Box H, Old Capitol Annex
Frankfort, KY 40601
(502)564-3016

LOUISIANA

Clarence H. Webb, Chmn.
Archeological Survey, &
Antiquities Comm.
P.O. Box 44247
Baton Rouge, LA 70804
(504)342-6682

MAINE

Eugene S. Ashton, Chmn.
Historic Preservation Comm.
Dept. of Educ. & Cultural Ser.
State House, Station #65
Augusta, ME 04333
(207)289-2133

MARYLAND

Margaret S. Yewell, Chpn.
Historical Trust
Dept. of Econ. & Community Dev.
21 State Circle
Annapolis, MD 21401
(301)269-2212

MASSACHUSETTS

Patricia L. Weslowski, Dir.
Historical Comm.
Office of Secy. of Commonwealth
294 Washington St.
Boston, MA 02108
(617)727-8470

MICHIGAN

Martha Bigelow, Dir.
Div. of Michigan History
208 N. Capitol
Lansing, MI 48918
(517)373-6362

MINNESOTA

Russell W. Friedley, Dir.
Historical Society
Historical Bldg.
690 Cedar St.
St. Paul, MN 55101
(612)296-2747

MISSISSIPPI

Robert Bailey, Dir.
Div. of Historical Preservation
Dept. of Archives & History
600 E. Amite
Jackson, MS 39205
(601)354-7326

MISSOURI

John Karel, Dir.
Div. of Parks & Hist. Preser.
Dept. of Natural Resources
P.O. Box 176
Jefferson City, MO 65102
(314)751-4321

MONTANA

Robert Archibald, Dir.
Administration Program
Historical Society
225 N. Roberts
Helena, MT 59620
(406)449-2694

NEBRASKA

Marvin F. Kivett, Dir.
Historical Society
1500 R. St.
Lincoln, NE 68508
(402)471-3270

NEVADA

John Scott Miller, Dir.
State Museum
600 N. Carson St.
Carson City, NV 89710
(702)885-4810

NEW HAMPSHIRE

George T. Gilman, Commr.
Dept. of Res. & Econ. Dev.
Six Loudon Rd.
Concord, NH 03301
(603)292-2023

NEW MEXICO

Thomas W. Merlan, Dir.
Bur. of Historic Preservation
Dept. of Finance & Admin.
126 E. DeVargas
Santa Fe, NM 87503
(505)827-2108

NEW YORK

Ann Webster Smith, Dep. Commr.
Office of Parks & Recreation
Empire State Plaza, Agency
Bldg. One
Albany, NY 12238
(518)474-0468

NORTH CAROLINA

John T. Little, Dir.
Archaeology & Hist. Preser.
Dept. of Cultural Resources
109 E. Jones St.
Raleigh, NC 27611
(919)733-4763

NORTH DAKOTA

Louis Haffermehl, Dir.
Archeology & Historical Preser.
Historical Society
Heritage Center
Bismarck, ND 58505
(701)224-2672

N. MARIANA ISLANDS

Jesus B. Pangelinan, Chf.
Office of Historic Preservation
Community & Cultural Affairs
Saipan, CM 97950
Overseas 9411

OHIO

Gary C. Ness, Dir.
Historical Society
1982 Velma Ave.
Columbus, OH 43211
(614)466-1500

OKLAHOMA

Melvena Thurman, Dir.
Div. of Historic Preservation
Historical Society
Wiley Post Bldg.
Oklahoma City, OK 73105
(405)521-2491

OREGON

David Powers, Hist. Preser. Offr.
Div. of Parks & Recreation
Dept. of Transportation
525 Trade St., SE
Salem, OR 97310
(503)378-5002

PENNSYLVANIA

Ed Weintraub, Dir.
Office of Historic Preser.
Historical & Museum Comm.
531 William Penn Museum
Harrisburg, PA 17120
(717)787-4363

PUERTO RICO

Leticia del Rosario, Dir.
Inst. of Puerto Rican Culture
P.O. Box 4184
San Juan, PR 00905
(809)724-0700

RHODE ISLAND

Eric Hartfelder, Exec. Dir.
Historical Preservation Comm.
150 Benefit St.
Providence, RI 02903
(401)277-2678

SOUTH CAROLINA

Christi L. Fant, Asst. Dir.
Dept. of Archives & History
1430 Senate St.
P.O. Box 11669
Columbia, SC 29211
(803)758-5816

SOUTH DAKOTA

Dayton Canaday, Historian
Div. of Cultural Preservation
Education & Cultural Affairs
Kneip Bldg.
Pierre, SD 57501
(605)773-3458

TENNESSEE

Herbert Harper, Exec. Dir.
Historical Comm.
Dept. of Conservation
4721 Trousdale Dr.
Nashville, TN 37211
(615)741-2371

TEXAS

Truett Latimer, Exec. Dir.
Historical Comm.
P.O. Box 12276, Capitol Station
Austin, TX 78711
(512)475-3092

UTAH

Melvin T. Smith, Dir.
Div. of State History
Dept. of Community & Econ. Dev.
300 Rio Grande
Salt Lake City, UT 84101
(801)533-5755

VERMONT

William B. Pinney, Dir.
Div. of Historic Preservation
Agency of Dev. & Community Aff.
Pavilion Office Bldg.
Montpelier, VT 05602
(802)828-3226

VIRGINIA

Tucker Hill, Dir.
Historic Landmarks Comm.
221 Governor St.
Richmond, VA 23219
(804)786-3143

WASHINGTON

Jacob Thomas, Hist. Preser. Offr.
Archaeology & Hist. Preser.
111 W. 21st St.
Olympia, WA 98504
(206)753-5010

WEST VIRGINIA

Rodney Pyles, Dir.
Div. of Archives & History
Dept. of Culture & History
Science & Culture Center
Charleston, WV 25305
(304)348-0230

WISCONSIN

Jeff M. Dean, Dir.
Div. of Historic Preservation
Historical Society of Wisconsin
816 State St.
Madison, WI 53706
(608)262-1339

WYOMING

Jan Wilson, Dir.
Recreation Comm.
604 E. 25th
Cheyenne, WY 82001
(307)777-76795

APPENDIX E-8

ADDRESSES OF STATE AGENCIES RESPONSIBLE FOR
ENERGY CONSERVATION AND RENEWABLE ENERGY DEVELOPMENT

ALABAMA

Jack Raven, Dir.
Dept. of Energy
Office of the Governor
3734 Atlanta Hwy.
Montgomery, AL 36130
(205)832-5010

ALASKA

Lloyd Pernela, Dir.
Div. of Energy & Power Dev.
Dept. of Commerce & Econ. Dev.
338 Denali St.
Anchorage, AK 99501
(907)276-0508

AMERICAN SAMOA

Matt Le'i, Dir.
Office of Energy
Fagatogo
Pago Pago, AS 96799
633-1306

ARIZONA

Margaret M. Walker, Dir.
Office of Energy
Executive Tower, 5th Fl.
1700 W. Washington
Phoenix, AZ 85006
(602)255-3303

ARKANSAS

Cherry Duckett, Dir.
Office of Energy
Dept. of Indus. Dev. Comm.
One Capitol Mall
Little Rock, AR 72201
(501)371-1370

CALIFORNIA

Russell L. Schweickart, Chmn.
Energy Resources Conserv. &
Dev. Comm.
1111 Howe Ave.
Sacramento, CA 95825
(916)920-7709

COLORADO

Joe Zettel, Actg. Exec. Dir.
Office of Energy Conservation
Office of the Governor
1525 Sherman, 4th Fl.
Denver, CO 80203
(303)866-2507

CONNECTICUT

Bradford S. Chase, Under Secy.
Div. of Energy
Office of Policy & Management
80 Washington St.
Hartford, CT 06115
(203)566-2800

DELAWARE

Donald A. Crews, Actg. Dir.
Administrative Ser.
Office of Energy
O'Neill Bldg.
Dover, DE 19901
(302)736-4706

FLORIDA

James M. Harvey, Dir.
Office of State Energy
Bryant Bldg., Rm. 301
Tallahassee, FL 32301
(904)488-6764

GEORGIA

Mark Zwecker, Dir.
Office of Energy Resources
270 Washington St., Rm. 615
Atlanta, GA 30334
(404)656-5176

GUAM

Joe Lather, Adminstr.
Office of Energy
P.O. Box 2950
Agana, GU 97910
(671)472-8711

HAWAII

Alfred S. Harris, Mgr.
Office of State Energy
Dept. of Plan. & Econ. Dev.
335 Merchant St., Suite 110
Honolulu, HI 96813
(808)548-4080

IDAHO

Kenneth N. Green Adminstr.
Div. of Energy
Dept. of Water Resources
State House
Boise, ID 83720
(208)334-4695

ILLINOIS

Mike Witte, Actg. Dir.
Dept. of Energy & Nat. Res.
325 W. Adams St.
Springfield, IL 62706
(217)785-2800

INDIANA

Clarence D. Broadus, Dir.
Dept. of Commerce
Energy Group
440 N. Meridian St.
Indianapolis, IN 46204
(317)232-8940

IOWA

Robert F. Tyson, Dir.
Energy Policy Council
Lucas Bldg.
Des Moines, IA 50319
(515)281-4420

KANSAS

(Vacancy), Dir.
Office of Energy
214 W. Sixth
Topeka, KS 66603
(913)296-2496

KENTUCKY

William B. Sturgill, Secy.
Office of the Secretary
Dept. of Energy
Iron Works Pk., P.O. Box 11888
Lexington, KY 40578
(606)252-5535

LOUISIANA

T. C. Landrum, Dir.
Div. of Research & Dev.
Dept. of Natural Res.
P.O. Box 44396
Baton Rouge, LA 70804
(504)342-4594

MAINE

Gordon L. Weil, Dir.
Iceff. of Energy Resources
Executive Dept.
State House, Station #53
Augusta, ME 04333
(207)289-3811

MARYLAND

Paul Massicot, Dir.
Energy Administration
Dept. of Natural Resources
Tawes State Office Bldg.
Annapolis, MD 21401
(301)269-2788

MASSACHUSETTS

Joseph S. Fitzpatrick, Secy.
Energy Resources
Office of State Energy
73 Tremont St., Rm. 700
Boston, MA 02108
(617)727-4732

MICHIGAN

Joann Neuroth, Actg. Dir.
Energy Administration
5520 Mercantile Way, #1
P.O. Box 30228
Lansing, MI 48909
(517)374-9090

MINNESOTA

John Armstrong, Asst. Dir.
Div. of Conservation
Energy, Planning & Dev.
150 E. Kellogg Blvd.
St. Paul, MN 55101
(612)296-9098

Kent Eklund, Commr.
Energy, Planning & Dev.
101 Capitol Square Bldg.
550 Cedar St.
St. Paul, MN 55101
(612)297-2997

MISSISSIPPI

Wilbur G. Ball, Exec. Dir.
Dept. of Energy & Trans.
Watkins Bldg., Suite 300
510 George St.
Jackson, MS 39202
(601)961-4733

MISSOURI

Al Pasini, Dir.
Div. of Energy
Dept. of Natural Resources
P.O. Box 176
Jefferson City, MO 65102
(314)751-4000

MONTANA

Robert Robinson, Adminstr.
Div. of Energy
Natural Resources & Conserv.
25 S. Ewing
Helena, MT 59620
(406)449-3780

NEBRASKA

Vincent Balok, Dir.
Office of State Energy
State Capitol, 9th Fl.
Lincoln, NE 68509
(402)471-2867

NEVADA

Steve A. Robinson, Dir.
Dept. of Energy
1050 E. William St.
Carson City, NV 89710
(702)885-5157

NEW HAMPSHIRE

Michael R. Cornelius, Dir.
Governor's Council on Energy
2 1/2 Beacon St.
Concord, NH 03301
(603)271-2711

NEW JERSEY

Joel R. Jacobson, Commr.
Dept. of Energy
1100 Raymond Blvd.
Newark, NJ 07102
(201)648-3290

NEW MEXICO

Lary Kehoe, Secy.
Dept. of Energy & Minerals
113 Washington Ave.
Santa Fe, NM 87501
(505)473-4376

NEW YORK

James L. LaRocca, Commr.
Office of Energy
Executive Dept.
Empire State Plaza, Bldg. 2
Albany, NY 1223
(518)473-4376

NORTH CAROLINA

Doug Culbreth, Dir.
Div. of Energy
Dept. of Commerce
430 N. Salisbury St.
Raleigh, NC 27611
(919)733-2230

NORTH DAKOTA

Bruce Westerberg, Dir.
Energy Management & Conserv.
Office of the Lt. Governor
State Capitol, 17th Fl.
Bismarck, ND 58505
(701)224-2250

N. MARIANA ISLANDS

George Chan, Chf. Planner
Office of Physical Planning
Office of Planning & Budget Aff.
Saipan, CM 96950
Overseas 7174

OHIO

Robert Masoner, Dir.
Dept. of Energy
30 E. Broad St., 34th Fl.
Columbus, OH 43215
(614)466-3465

OKLAHOMA

Gail Scott, Dir.
Div. of Conservation Ser.
Corporation Comm.
Jim Thorpe Bldg., Rm. 302
Oklahoma City, OK 73105
(405)521-2211

OREGON

Lynn Frank, Dir.
Dept. of Energy
Labor & Industries Bldg., Rm. 111
Salem, OR 97310
(503)378-4040

PENNSYLVANIA

Robert A. Shinn, Exec. Dir.
Governor's Energy Council
300 N. Second St.
Harrisburg, PA 17102
(717)787-2814

RHODE ISLAND

Edward F. Burke, Chmn.
Pub. Utility Comm.
100 Orange St.
Providence, RI 02903
(401)277-3374

SOUTH CAROLINA

B. Kelly Smith, Dir.
Off. of Energy Resources
1122 Lady St., #1120
Columbia, SC 29201
(803)758-7502

SOUTH DAKOTA

Charles Verderzeil, Dir.
Office of Energy Policy
Capitol Lake Plaza
Pierre, SD 57501
(605)773-3603

TENNESSEE

Lee Munz, Exec. Dir.
Energy Authority
226 Capitol Blvd. Bldg.
Nashville, TN 37219
(512)475-0414

UTAH

Jim Burns, Dir.
Div. of Energy
Dept. of Energy & Natural Res.
231 E. 400 S., Rm. 101
Salt Lake City, UT 84111
(801)533-5424

VERMONT

Margaret Garland, Dir.
Office of State Energy
Dept. of Public Service
State Office Bldg.
Montpelier, VT 05602
(802)828-2393

VIRGINIA

H. Kim Anderson, Coord.
Office of Emergency Ser.
310 Turner Dr.
Richmond, VA 23225
(804)745-3305

WASHINGTON

Edward W. Sheets, Dir.
Office of State Energy
400 E. Union Ave.
Olympia, WA 98504
(206)753-0700

WEST VIRGINIA

Jim Maddy, Dir.
Energy Development
Capitol Complex #6, Rm. 531
Charleston, WV 25305
(304)348-0400

WISCONSIN

Eileen Ryan Polizzotto, Adminstr.
Div. of State Energy
Dept. of Administration
101 S. Webster, 8th Fl.
Madison, WI 53702
(608)266-8234

WYOMING

Pamela Abel, Coord.
Office of Energy Conservaton
Capitol Hill Office Bldg.
25th and Pioneer
Cheyenne, WY 82001
(307)777-7131

APPENDIX E-9

ADDRESSES OF STATE AGENCIES
RESPONSIBLE FOR NATURAL RESOURCES

ALABAMA

John McMillian, Commr.
Dept. of Conser. & Natural Res.
Administration Bldg., Rm. 702
Montgomery, AL 36130
(205)832-6316

ALASKA

John Katz, Commr.
Dept. of Natural Resources
Pouch M
Juneau, AK 99811
(907)465-2400

ARIZONA

Joseph T. Fallini, Commr.
Dept. of Lands
1624 W. Adams
Phoenix, AZ 85007
(602)255-4621

ARKANSAS

Shirley J. Thomas, Dir.
Dept. of Commerce
One Capitol Mall
Little Rock, AR 72201
(501)371-2231

CALIFORNIA

Jan Denton, Dir.
Dept. of Conservation
1416 Ninth St., Rm. 1320
Sacramento, CA 95814
(916)322-1080

COLORADO

Monte Pascoe, Exec. Dir.
Dept. of Natural Resources
Centennial Bldg., 7th Fl.
Denver, CO 80203
(303)866-3311

CONNECTICUT

Stanley J. Pac, Commr.
Dept. of Environmental Prot.
165 Capitol Ave., Rm. 117
Hartford, CT 06115
(203)566-2110

DELAWARE

John E. Wilson, Secy.
Dept. of Natural Resources &
Environmental Control
Tatnall Bldg.
Dover, DE 19901
(302)736-4403

FLORIDA

Elton J. Gissendanner, Exec. Dir.
Dept. of Natural Resources
3900 Commonwealth Ave.
Tallahassee, FL 32303
(904)488-1555

GEORGIA

Joe D. Tanner, Commr.
Dept. of Natural Resources
270 Washington St., SW
Atlanta, GA 30334
(404)656-3500

GUAM

William Null, Chf.
Div. of Natural Resources
Dept. of Agriculture
P.O. Box 23367
Agaña, GU 96910
(671)734-3948

HAWAII

Susumu Ono, Chmn.
Bd. of Land & Natural Res.
1151 Punchbowl St.
Honolulu, HI 96813
(808)548-2800

INDIANA

James M. Ridenour, Dir.
Dept. of Natural Resources
State Office Bldg, Rm. 608
Indianapolis, IN 56204
(317)232-4020

IOWA

James R. Webb, Dir.
Natural Resources Council
Wallace Bldg.
Des Moines, IA 50319
(515)281-5913

KENTUCKY

Jackie Swigert, Secy.
Office of the Secretary
Natural Res. & Envir. Prot.
Capital Plaza Tower
Frankfort, KY 50601
(502)564-3350

LOUISIANA

Frank Ashby, Jr., Secy.
Dept. of Natural Resources
P.O. Box 44396
Baton Rouge, LA 70804
(504)342-4503

MARYLAND

James B. Coulter, Secy.
Dept. of Natural Resources
Tawes State Office Bldg.
Annapolis, MD 21401

MASSACHUSETTS

William F. M. Hicks, Commr.
Dept. of Environmental Mgt.
Office of Environmental Aff.
100 Cambridge St.
Boston, MA 02202
(617)727-3163

MICHIGAN

Howard A. Tanner, Dir.
Dept. of Natural Resources
Mason Bldg., 7th Fl.
P.O. Box 30028
Lansing, MI 58909
(517)373-2329

MINNESOTA

Joesph N. Alexander, Commr.
Dept. of Natural Resources
658 Cedar St.
St. Paul, MN 55155
(612)296-6157

MISSISSIPPI

Charley Blalock, Exec. Dir.
Dept. of Natural Resources
Southport Mall
2380 Hwy. 80 W.
Jackson, MS 39209
(601)961-5000

MISSOURI

Fred A. Lafser, Dir.
Dept. of Natural Resources
1915 Southridge Dr.
P.O. Box 176
Jefferson City, MO 65102
(314)751-4422

MONTANA

Leo Berry, Dir.
Natural Resources & Conser.
32 S. Ewing
Helena, MT 59620
(406)449-3712

NEBRASKA

Dayle E. Williamson, Exec. Secy.
Natural Resources Comm.
301 Centennial Mall, S.
Lincoln, NE 68509
(402)471-2081

NEVADA

Roland D. Westergard, Dir.
Dept. of Conserv. & Nat. Res.
201 S. Fall St.
Carson City, NV 89710
(702)885-4360

NEW HAMPSHIRE

George T. Gilman, Commr.
Dept. of Res. & Econ. Dev.
Six Loudon Rd.
Concord, NH 03301
(603)271-2411

NEW JERSEY

Jerry F. English, Commr.
Dept. of Environmental Prot.
CN-402
Trenton, NJ 08625
(609)292-2885

NEW MEXICO

William S. Huey, Secy.
Dept. of Natural Resources,
Villagra Bldg.
Santa Fe, NM 87503
(505)827-3167

NEW YORK

Robert F. Flacke, Commr.
Dept. of Environmental Conserv.
50 Wolf Rd.
Albany, NY 12233
(518)457-3446

NORTH CAROLINA

Joseph W. Grimsley, Secy.
Dept. of Natural Res. &
Community Dev.
512 N. Salisbury St.
Raleigh, NC 27611
(919)733-4984

N. MARIANA ISLANDS

Pedro Dela Cruz, Dir.
Natural Resources
Saipan, CM 96950
OVERSEAS 7125

OHIO

Robert W. Teater, Exec. Dir.
Dept. of Natural Resources
Fountain Square
Columbus, OH 53224
(614)466-3770

OREGON

Pat Amadeo, Asst. to Gov.
Office of the Governor
State Capitol, Rm. 160
Salem, OR 97310
(503)378-3109

PENNSYLVANIA

Peter Duncan, Actg. Secy.
Dept. of Environmental Res.
Fulton Bldg., 9th Fl.
Harrisburg, PA 17120
(717)787-2814

PUERTO RICO

Hilda Diaz Soltero, Secy.
Dept. of Natural Resources
P.O. Box 5887
San Juan, PR 00906
(809)723-3090

RHODE ISLAND

W. Edward Wood, Dir.
Dept. of Environmental Mgt.
83 Park St.
Providence, RI 02903
(401)277-2771

SOUTH CAROLINA

Benn Gregg, Dir.
Div. of Natural Resources
Office of the Governor
1205 Pendleton St.
Columbia, SC 29211
(803)758-8808

SOUTH DAKOTA

Warren Neufeld, Secy.
Dept. of Water & Natural Res.
Foss Bldg., 2nd Fl.
Pierre, SD 57501
(605)773-3151

TENNESSEE

Charles A. Howell, Commr.
Dept. of Conservation
2611 West End Ave.
Nashville, TN 37203
(615)741-2301

UTAH

Temp Reynolds, Exec. Dir.
Dept. of Natural Resources
231 E. Fourth S.
Salt Lake City, UT 84111
(801)533-5356

VERMONT

Brendan Whittaker, Secy.
Agcy. of Environmental Conserv.
79 River St.
Montpelier, VT 05602
(802)828-3130

VIRGINIA

Maurice B. Rowe, Secy.
Office of Commerce & Resources
Ninth St. Office Bldg., Rm. 514
Ninth & Grace Sta.
Richmond, VA 23219
(804)786-7831

WASHINGTON

Brian J. Boyle, Commr.
Dept. of Natural Resources
Public Lands Bldg.
Olympia, WA 98504
(206)753-5317

WEST VIRGINIA

David C. Callaghan, Dir.
Dept. of Natural Resources
Capitol Complex #3, Rm. 669
Charleston, WV 25305
(304)348-2754

WISCONSIN

Carroll D. Besadny, Secy.
Dept. of Natural Resources
101 S. Webster St., 5th Fl.
Madison, WI 53602
(608)266-2121

APPENDIX F

MANUFACTURERS AND SUPPLIERS OF
EQUIPMENT FOR HYDROPOWER INSTALLATIONS
SMALLER THAN 100 kW

Following is a list of some of the manufacturers and suppliers of equipment for hydropower installations of less than 100 kW output:

	Supplier	Code ^a	Notes
1.	Alaska Wind and Water Power P.O. Box G, Chugiak, AK 99567 (907) 688-2896	M SS C	
2.	Cornell Pump Company 2323 S.E. Harvester Drive Portland, OR 97222 (503) 653-0330	M SS	Reaction turbines
3.	Dependable Turbines Limited No. 7-3005 Moody Street Port Moody, BC V3H1X3 (604) 461-3121	M SS C	Pelton, Turgo, Francis and propeller turbines
4.	Canyon Industries 5346 Mosquito Lake Road Deming, WA 98244	M	Pelton, propeller and crossflow turbines
5.	McKay Water Power, Inc. P.O. Box 221 West Lebanon, N.H. 03784 (603) 298-5122	M SS R C	Pelton, Francis, Turgo turbines
6.	Gilkes Pumps Inc. P.O. Box 628, Seabrook, TX 77586 (713) 474-3016	SS	
7.	Hydro-Heat Corporation Croton Falls Executive Park Croton Falls, NY 10519	M SS	
8.	GSA International Corp. 223 Katonah Ave. Katonah, NY 10536	C SS R	Consultant associate with Hydro-Heat Corp. Delton, Francis, Propeller Turbines
9.	Hydrolec by Leroy-Somer Chic 16 Passaic Ave. Fairfield, NJ 07006 (212) 732-4872	M SS	Turbines manufactured in France

	Supplier	Code ^a	Notes
10.	New England Energy Development Systems Inc. 109 Main Street Amherst, MA 01002 (413) 256-8466	C F SS	HYDROLEC propeller and Pelton turbines manufactured by Leroy-Somer.
11.	Hydro-Watt Systems 146 Siglun Rd. Coos Bay, OR 97420	SS C	Pelton, crossflow, Francis turbines
12.	Leffel Hydro Energy P.O. Box 1607, Springfield, OH 45501 (513) 323-6431	M	Vertical Francis turbines standard design for 100 kW or less and head range of 5 to 50 ft.
13.	C. Macleod Corp. P.O. Box 286 Glenmoore, PA 19343 (215) 458-8133	M	Small Francis turbines
14.	Essex Turbine Company, Inc. Kettle Grove Industrial Park Magnolia, MA 01930 (617) 525-3523	M C	Standardized bulb turbines, 75 kW minimum size, for low head applications
15.	Nuway of Living, Inc. P.O. Box 562 Dayton, OR 97114	SS M	Supply Leffel turbines, Electronic controls, trash racks, fish ladders and penstocks.
16.	Obermeyer Hydraulic Turbines Ltd. 10 Front Street Collinsville, CT 06022 (203) 693-4292	M	Specialty is axial flow turbines. Also Francis, crossflow and Pelton turbines
17.	Small Hydroelectric Systems and Equipment, 5141 Wickersham Acme, WA 98220 (206) 595-2312	M C R	"Peltech" Pelton wheel turbine. For advice call (206) 595-2225.
18.	Voest-Alpine International Corp. 60 E. 42nd St. New York, NY 10165 (212) 661-1060	M SS	Pelton, Francis and axial flow turbines. Standardized and custom designs. Manufactured in Austria. Standardized design from 10 kW up
19.	Cascade Patterns 1309 Glenwood Dr. Mount Vernon, WA 98273	R	Provide Patterns for castings

	Supplier	Code ^a	Notes
20.	Almanor Machine Wks 413-A Arbutus Dr. Lake Almanor Pen., CA 96137	R M C	Rebuild and repair of units.
21.	Allis-Chalmers Box 712 York, PA 17405	M SS	Mini tube turbines.
22.	Appropriate Technologies P.O. Box 1016 Idaho Falls, ID 83401 208 529-1611	C M SS	Pelton, propeller and crossflow turbines
23.	General Energy Development 1881 W. Washington Stayton, OR 97383	C F	
24.	Meinikheim Machine P.O. Box 5 Banks, ID 83602	M	
25.	Worthington Group McGraw-Edison Comp. M 5310 Taney Town Pike P.O. Box 91 Taney Town, MD 21787 301-756-2602	M	Pumps as turbine
26.	Small Hydroelectric Engineering and Equipment P.O. Box 202 Hoodsport, WA 98548	C SS M F	
27.	Heron Turbomachinery, Corp. R. D. 7 Box 125 Reading, PA 19606	SS	
28.	McMillan Hydro Division Co. P.O. Box 226 Round Mountain, CA 96084	M SS	Pelton Wheels

Supplier	Code ^a	Notes
29. Independent Power Developers P.O. Box 1467 Noxon, Mt 59853	M	
a. C--Consulting M--Original manufacturer SS--System assembler and sales. R--Rebuild and repair F--Financing consultant		

APPENDIX G
GLOSSARY, ABBREVIATIONS,
AND
CONVERSION TABLES

ABBREVIATIONS AND SYMBOLS

Q	Flow
h	Head
e	Efficiency
cfs	Cubic feet per second
W	Watt
kW	Kilowatt
kWh	Kilowatt-hour
psi	Pounds per square inch
\$	Dollars
FT	Feet
FT ³	Cubic feet
FT ²	Square feet
in ²	Square inch
in ³	Cubic inch
lb	Pound
hp	Horsepower
%	Percentage
η_s	Specific Speed

CONVERSION TABLES

<u>Multiply</u>	<u>By</u>	<u>To Obtain</u>
Gallons	0.134	Cubic Feet
Cubic Feet	7.481	Gallons
Minutes	60.0	Seconds
Seconds	0.017	Minutes
Kilowatts	1.341	Horsepower
Horsepower	0.745	Kilowatts
Cubic feet per second	448.83	Gallons per minute
Gallons per minute	0.002228	Cubic feet per second
Pounds per square inch	2.0360	Feet of water
Feet of water	0.433	Pounds per square inch

METRIC

<u>Multiply</u>	<u>By</u>	<u>To Obtain</u>
Gallons	3.785	Liters
Gallons	0.00378	Cubic Meters
Cubic feet	28.316	Liters
Cubic feet per second	28.316	Liters per second
Gallons per minute	0.0638	Liters per second
Cubic feet per second	0.0283	Cubic meters per second
Gallons per minute	6.3088×10^{-5}	Cubic meters per second
Liters	0.26418	Gallons
Cubic meters	264.18	Gallons
Cubic meters per second	15850.3	Gallons per minute
Pounds per square inch	6894.76	Pascal

METRIC POWER EQUATION

$$P = 9.81 \times Q \times H \times e$$

where

P = power in kW

Q = flow in cubic meters per second

H = head in meters

e = efficiency in %

9.81 = conversion constant

Glossary

A.

ALTERNATING CURRENT (ac)--An electric current that reverses its direction of flow periodically (see direct current). Current is measured in amperes.

AMPACITY--The current carrying capacity or rating of the wire or component.

ANADROMOUS FISH--Fish, such as salmon, that ascend rivers from the sea at certain seasons to spawn.

AVAILABLE FLOW--That part of the flow in a stream which can be used to generate energy.

AVERAGE LOAD--The hypothetical constant load over a specified time period that would produce the same energy as the actual load would produce for the same period.

B

BASELOAD--The minimum load over a given period of time.

BASELOAD CAPACITY--Generating capacity operated to serve baseload.

BUS--An electrical conductor that serves as a common connection for two or more electrical circuits. A bus can be in the form of rigid bars, either circular or rectangular in cross section, or of stranded-conductor overhead cables held under tension.

BUSBAR--An electrical conductor in the form of rigid bars, located in switchyard or power plants, serving as a common connection for two or more electrical circuits.

C

CAPACITOR--A dielectric device that momentarily absorbs and stores electrical energy.

CAPACITY--The power output or load for which a turbine-generator unit is rated.

CAPACITY FACTOR--The ratio of the average demand on a machine or equipment for the period of time considered, to the capacity rating of the machine or equipment. The meaning can be extended to a plant or a system.

CAPACITY VALUE--That part of the market value of electric power that is assigned to dependable capacity.

CATEGORY 1 DEVELOPER--A developer whose primary motive is to generate energy for personal needs.

CATEGORY 2 DEVELOPER--A developer whose primary motive is to generate the maximum energy for the dollar invested.

CIRCUIT BREAKER--A switch that automatically opens an electric circuit carrying power when an abnormal condition occurs.

COMPOSITE POWER VALUE--A market value of electric power that includes a value for both dependable capacity and energy generated.

CONNECTED LOAD--The sum of the ratings of the electric power consuming apparatus connected to the system, or part of the system, under consideration.

CRITICAL STREAMFLOW--The amount of streamflow available for hydroelectric power generation during the most adverse streamflow period. Corresponds to 100% exceedance on the flow duration curve.

CRITICAL DRAWDOWN PERIOD--The time period between maximum pool drawdown and the previous occurrence of full pool.

D

DEBT SERVICE--Principal and interest payments on the debt used to finance the project.

DEMAND--See LOAD.

DESIGN CAPACITY--The power capacity computed with Equation (2.2) using the design head and flow in the equation.

DESIGN FLOW--The flow used to size and select equipment for the hydropower system. Represents the maximum flow to pass through the system.

DESIGN HEAD--The head input used in the power equation to calculate power or flow.

DEPENDABLE CAPACITY--The capacity, which for a specified time interval and period, can be relied on to carry system load, provide assured reserve, and meet firm power obligations, taking into account unit operating variables, hydrologic conditions, and seasonal or other characteristics of the load to be supplied.

DIRECT CURRENT (dc)--Electricity that flows continuously in one direction (see alternating current).

DISPATCHING--The operating control of an integrated electric system involving operations such as:

- o The assignment of load to specific generating stations and other sources of supply to effect the most reliable and economical supply as the total of significant area loads rise or fall.
- o The control of operation and maintenance of high-voltage lines, substations, and equipment, including administration of safety procedures.

- o The operation of principal tielines and switching.
- o The scheduling of energy transactions with connecting electric utilities.

DIVERSION DAM--A dam used in conjunction with long tunnels, canals, or pipelines to divert water to a powerhouse located some distance from the dam.

DRAWDOWN--The distance that the water surface of a reservoir is lowered from a given elevation as the result of the withdrawal of water.

DURATION ANALYSIS--An analysis that calculates the exceedance values used to develop data for the flow duration curve.

E

EFFICIENCY--A percentage obtained by dividing the theoretical power or energy by the actual power or energy. Efficiency represents how well the hydropowered system converts the energy of the water into electrical energy [Equation (2.3)].

ELECTRIC POWER--A term used in the electric power industry to mean inclusively power and energy.

ELECTRIC SYSTEM LOSS--Total electric energy loss in the electric system. It consists of transmission, transformation, and distribution losses, and unaccounted-for-energy-losses between sources of supply and points of delivery.

ENERGY--The capacity for performing work. The electrical energy term generally used is kilowatt-hours and represents power (kilowatts) operating for some time period (hours).

ENERGY LOSS--The difference between energy input and output as a result of transfer of energy between two points.

EXCEEDANCE VALUES--Percentage that represents the percent of time that the corresponding flow is met or exceeded.

F

FEDERAL ENERGY REGULATORY COMMISSION (FERC)--An agency in the Department of Energy that licenses non-Federal hydropower projects and regulates interstate transfer of electric energy. Formerly the Federal Power Commission (FPC).

FIRM ENERGY--The energy generation ability of a hydropower plant under adverse hydrologic conditions for the time interval and period specified of a particular system load.

FLOW--The amount of water passing a point in a given amount of time
[Equation (2.1)]

FLOW DURATION CURVE--A curve of flow values plotted against the percentage of time that flow is met or exceeded.

FORCED OUTAGE--The shutting down of a generating unit, transmission line, or system for emergency reasons.

FOREBAY--The water intake area for a canal, penstock, or turbine designed to reduce water velocity and turbulence in order to settle suspended material and keep it from entering the system.

FRANCIS TURBINE--A reaction-type turbine that uses the combined action of pressure and velocity of the water to drive generating equipment. Water enters the unit radially and leaves axially.

G

GENERATION (NET)--Gross generation less plant use.

GENERATOR--A machine that converts mechanical energy into electric energy.

GENERATING CAPABILITY--The maximum load that a system can supply without exceeding approved limits of temperature and stress.

GENERATION AND TRANSMISSION COOPERATIVE--Electric utility cooperative that generates and transmits electric power, usually at wholesale rates, to distribution cooperatives and other member systems.

GIGAWATT (GW)--One million kilowatts.

GRID--The transmission network interconnecting electric power systems or bulk power components of a single system.

GROSS GENERATION--The total amount of electric energy produced by a generating station or stations, measured at the generator terminals.

H

HERTZ--Cycles per second of generated voltage and current flow.

HORSEPOWER--A unit of power equal to 550 foot-pounds per second, or 745.7 watts.

HYDRAULIC HEAD--The difference in hydraulic pressure between two points, expressed in terms of the vertical length of a column of water that represents the same pressure; the elevation between the headwater surfaces above and the tailwater surface below a hydroelectric power plant.

- o CRITICAL--The head at which the full gate output of the turbine equals the nameplate capacity of the generator.
- o GROSS (POOL-TO-POOL)--The difference in elevation between the headwater surfaces above and the tailwater surface below a hydroelectric powerplant, under specified conditions.
- o NET EFFECTIVE--The gross head less all hydraulic losses except those chargeable to the turbine.
- o OPERATING--The hydraulic head existing during operation of a hydroelectric plant, often expressed as a range.

HYDROELECTRIC ENERGY--Electric energy generated from a hydroelectric plant.

HYDROELECTRIC GENERATOR--A turbine and generator connected together for the purpose of generating electric energy.

HYDROLOGY--Statistical science used by engineers to project future stream activity from past stream flow records.

HYDROELECTRIC PLANT--An electric powerplant in which turbine-generators are driven by falling water, thereby converting mechanical energy to electric energy.

IMPELLER--See RUNNER

INSTALLED CAPACITY--The total of the capacities shown on the nameplates of the generating units in a hydropower plant.

INTERCONNECTION--A transmission line joining two or more power systems through which power produced by one can be used by the other.

INTERRUPTIBLE LOAD--Electric load that may be curtailed at the supplier's discretion, or in accordance with a contractual agreement.

ISOHYETGRAPH--Graph showing geographic points of equal amounts of precipitation.

K

KAPLAN TURBINE--A hydraulic turbine using a propeller-type runner in which the pitch of the propeller blades and the position of the wicket gates are adjustable under load to achieve optimum performance in the generation of hydroelectric power. Most frequently used in the low to moderate-head range. Microhydropower runners are generally not adjustable without plant shutdown.

KILOVOLT (kV)--One thousand volts.

KILOWATT (kW)--One thousand watts.

KILOWATT-HOUR (kWh)--The work done in one hour by a device working at a constant rate of one kilowatt.

LINE LOSS--Energy loss and power loss in a transmission or distribution line.

LOAD--The amount of power needed (demand) to be delivered at a given point in an electric system. The rate at which electric energy is delivered to or by a system or to a piece of equipment expressed in kilowatts, kilovolt-amperes, or other suitable unit at a given instant or average over any designated period of time.

LOAD CURVE--A curve showing power (kilowatts) supplied, plotted against time of occurrence, and illustrating the varying magnitude of the load during the period covered.

LOAD FACTOR--The ratio of average load supplied during a designated period to the maximum peak load occurring in the same period.

M

MANMADE SOURCES--Microhydropower sources resulting from a manmade structure such as dams, canal drops, and industrial or domestic waste discharge.

MECHANICAL ENERGY--Energy available from a mechanical system such as a turbine.

MEGAWATT (MW)--One thousand kilowatts.

MEGAWATT-HOURS (MWh)--One thousand kilowatt-hours.

MICROHYDROPOWER--A hydroelectric plant with rated capacity of 100 kW or less.

N

NATURAL SOURCES--Microhydropower sources that use natural terrain or features to obtain head, such as waterfalls and run of the stream sites.

NAWDEX--National Water Data Exchange, a listing of all federal, state, and some private stream gauges in a given county.

NET ENERGY FOR SYSTEM--The electric energy requirements of a system, including losses, defined as: (a) net generation of the system, plus (b) energy received from others, less (c) energy delivered to other systems for resale.

OFF-PEAK--Periods of relatively low power system demands as specified by the supplier.

ON-PEAK--Periods of relatively high power system demands as specified by the supplier:

OUTAGE--The period in which a generating unit, transmission line, or other facility is out of service.

(IN) PARALLEL--Several units whose ac frequencies are exactly equal, operating in synchronism as part of the same electric system.

PEAK LOAD--The maximum load in a stated period of time.

PEAKING CAPACITY--That part of a system's capacity which is operated during the hours of highest power demand.

PELTON WHEEL--A hydraulic turbine in which the energy of water is converted through nozzles into high-velocity jets of water that drive a turbine by virtue of the forces the water jets exert on buckets attached to the turbine wheel. Also known as impulse turbines, they are generally used in high-head operation.

PENSTOCK--A closed conduit or pipe for conducting water to a powerhouse.

PLANT FACTOR--The ratio of the average load to the installed capacity of the plant, expressed as an annual percentage.

PONDAGE--The amount of water stored behind a hydroelectric dam of relatively small storage capacity, used for daily or weekly regulation of the flow of a river.

POWER (ELECTRIC)--The rate of generation or use of electric energy, usually measured in kilowatts. The time rate of transferring energy. The term is frequently used in a broad sense, as a commodity including both capacity and energy.

POWER EQUATION--The equation used to calculate power when head, flow, and efficiency are known [Equation (2.2)].

POWER FACTOR--The percentage ratio of the amount of power, measured in kilowatts, used by a consuming electric facility to the apparent power measured in kilovolt-amperes.

POWER POOL--Two or more interconnected electric systems that coordinate the planning or operation of their bulk power facilities for the purpose of achieving greater reliability and economy in accordance with contractual agreements that establish each member's responsibilities.

POWER-DURATION CURVE--A curve of power production capability values plotted in descending order of magnitude against time intervals for a specified period. The coordinates may be absolute quantities or percentages.

POWER-TRANSFER CAPACITY--The maximum power or load which can be transferred from one point to another over electric power transmission facilities.

PREFERENCE CUSTOMERS--Publicly-owned systems and nonprofit cooperatives that by law have preference over investor-owned systems for the purchase of power from Federal projects.

PRIME MOVER--The engine, turbine, waterwheel, or similar machine that drives an electric generator.

PROJECT SPONSOR--The entity controlling the small hydro site and promoting construction of the facility.

PROTECTIVE RELAYING--The incorporation of sensing devices (relays) in electric power systems to monitor and identify abnormalities in system characteristics, such as voltage, current, and frequency, and to actuate other pieces of equipment to correct or isolate detected abnormal operating conditions.

R

RADIAL INFLOW TURBINE--Water enters the turbine perpendicular to the turbine shaft and exits parallel to the turbine shaft.

RADIAL OUTFLOW TURBINE--Water enters the turbine parallel to the turbine shaft and exits perpendicular to the turbine shaft.

RATE OF RETURN ON INVESTMENT--The interest rate at which the present worth of annual benefits equals the present worth of annual costs.

RATED CAPACITY--The nameplate capacity of a generating unit in a hydroelectric powerplant.

RECONNAISSANCE STUDY--A preliminary feasibility study designed to ascertain whether a feasibility study is warranted.

REQUIRED CAPACITY--The power capacity needed by the developer, in kW.

RESERVE GENERATING CAPACITY--Extra capacity maintained to generate power in the event of unusually high demand or an unplanned outage of capacity.

RESERVE MARGIN--The difference between system capability and system peakload requirements. It is the margin of capability available to provide for scheduled outages, forced outages, system operating requirements including stability control and spinning reserves, and unforeseen loads.

REVERSIBLE CAPACITY--Capacity with characteristics permitting it to be used alternately as a motor-pump or turbine-generator.

RIPARIAN HABITAT--Referring to the habitat occurring on or near stream or river banks.

RIPRAP--Large loose rubble, rocks, debris, etc. used to protect stream banks or dam faces from erosion by flowing water or wave action.

RIVER REACHES--A continuous stretch of a stream or river.

RUNOFF--The portion of the precipitation on the land that ultimately reaches streams, especially the water from rain or melted snow that flows over the surface. The amount of surface water that passes a given point in a given area in its migration to streams or rivers.

RUN-OF-THE-STREAM PLANT--A hydroelectric powerplant using the flow of a stream as it occurs and having little or no reservoir capacity for storage.

RUNNER--The rotating element of a turbine that transforms the energy of falling water into rotating mechanical energy.

S

SCHEDULED OUTAGE--The scheduled shutdown of a generating unit, transmission line, or other facility for inspection, maintenance, or repair.

SPECIFIC SPEED--A constant used to compare different pump or turbine units and provide a means of characterizing all units. A criterion of similarity between different pumps or turbines.

SPINNING RESERVE--Generating units connected to the bus and ready to take load.

SURGE IMPEDANCE LOADING--Loading equal to the power that would be delivered by a line to a purely resistive load equal to its surge impedance, reflecting the special case where line resistance is zero and the surge impedance is equal to the square root of the ratio of the line inductance to the line capacitance.

SURPLUS POWER--Generating capacity that is not needed on the system at the time it is available.

SWITCHYARD--An assemblage of equipment for the purpose of tying electric generation to a transmission system.

SYSTEM, ELECTRIC--The physically connected generation, transmission, distribution, and other facilities operated as an integral unit under one control, management, or operating supervision.

T

TAILRACE--The water channel that transports the water discharged from the turbine draft tube to the canal, river, or stream.

TRANSFORMER--An electromagnetic device for changing the voltage of alternating current electricity.

TRANSMISSION--The act or process of transporting electric energy in bulk.

TRANSMISSION LINE CAPACITY---The maximum continuous rating of a transmission line. The rating may be limited by thermal considerations, capacity of associated equipment, voltage regulation, system stability or other factors.

TRANSMISSION SYSTEM--An interconnected group of electric transmission lines and associated equipment for the movement or transfer of electric energy in bulk between points of supply and points at which it is transformed for delivery to ultimate consumers, or is delivered to electric systems of others.

TURBINE--The part of a generating unit that is spun by the force of water or steam to drive an electric generator. The turbine usually consists of a series of curved vanes or blades on a central spindle.

TURBINE-GENERATOR--A rotary-type unit consisting of a turbine and an electric generator. (See TURBINE & GENERATOR)

APPENDIX H

LIST OF ENERGY LAW INSTITUTE STATE REPORTS

ENERGY LAW INSTITUTE STATE REPORTS

- ELI-80-17 Executive Summary: Legal Obstacles and Incentives to the Development of Small-Scale Hydroelectric power in the Six New England States, January 1979 (Connecticut, Maine, Massachusetts, New Hampshire, Rhode Island, Vermont), Rev. August 1980.
- ELI-79-9 Executive Summary: Legal Obstacles and Incentives to Small-Scale Hydroelectric Development in the Mid-Atlantic States, May 1979 (Delaware, Maryland, New Jersey, New York, Pennsylvania, Virginia)
- ELI-79-29 Executive Summary: Legal Obstacles and Incentives to the Development of Small-Scale Hydroelectric Potential in the Seven Midwestern States, August, 1979 (Illinois, Indiana, Kentucky, Michigan, Ohio, West Virginia, Wisconsin)
- ELI-79-38 Legal Obstacles and Incentives to the Development of the Small-Scale Hydroelectric Potential of Alaska, Rev. October 1979.
- ELI-80-19 Legal Obstacles and Incentives to the Development of Small-Scale Hydroelectric Power in Connecticut, Rev. August 1980.
- ELI-79-16 Legal Obstacles and Incentives to the Development of Small-Scale Hydroelectric Power in Delaware, August 1979.
- ELI- - Hawaii--Small-Scale Hydroelectric Policy Report, Preliminary Legislative Issues and options
- ELI-79-22 Legal Obstacles and Incentives to the Development of Small-Scale Hydroelectric Power in Illinois, August 1979.
- ELI-79-23 Legal Obstacles and Incentives to the Development of Small-Scale Hydroelectric Power in Indiana, August 1979.

- ELI-79-24 Legal Obstacles and Incentives to the Development of Small-Scale Hydroelectric Power in Kentucky, August 1979.
- ELI-80-20 An Analysis of Legal Obstacles and Incentives to the Development of Low-Head Hydroelectric Power in Maine, Rev. August 1980.
- ELI-79-17 Legal Obstacles and Incentives to the Development of Small-Scale Hydroelectric Power in Maryland, August 1979.
- ELI-80-21 Legal Obstacles and Incentives to the Development of Small-Scale Hydroelectric Power in Massachusetts, Rev. August 1980.
- ELI-79-25 Legal Obstacles and Incentives to the Development of Small-Scale Hydroelectric Power in Michigan, August 1979.
- ELI-80-22 Legal Obstacles and Incentives to the Development of Small-Scale Hydroelectric Power in New Hampshire, Rev. August 1980.
- ELI-79-18 Legal Obstacles and Incentives to the Development of Small-Scale Hydroelectric Power in New Jersey, August 1979.
- ELI-79-19 Legal Obstacles and Incentives to the Development of Small-Scale Hydroelectric Power in New York, August 1979.
- ELI-79-35 Legal and Institutional Obstacles and Incentives to the Development of Small-Scale Hydroelectric Power in North Carolina, September 1979.
- ELI-79-26 Legal Obstacles and Incentives to the Development of Small-Scale Hydroelectric Power in Ohio, August 1979.
- ELI-79-20 Legal Obstacles and Incentives to the Development of Small-Scale Hydroelectric Power in Pennsylvania, August 1979.

- ELI-80-23 Legal Obstacles and Incentives to the Development of Small-Scale Hydroelectric Power in Rhode Island, Rev. August 1980.
- ELI- - Legal and Institutional Obstacles and Incentives to the Development of Small-Scale Hydroelectric Power in South Carolina, Aug. 21, 1980.
- ELI-80-24 Legal Obstacles and Incentives to the Development of Small-Scale Hydroelectric Power in Vermont, Rev. August 1980.
- ELI-79-21 Legal Obstacles and Incentives to the Development of Small-Scale Hydroelectric Power in Virginia, August 1979.
- ELI-79-27 Legal Obstacles and Incentives to the Development of Small-Scale Hydroelectric Power in West Virginia, August 1979.
- ELI-79-28 Legal Obstacles and Incentives to the Development of Small-Scale Hydroelectric Power in Wisconsin, August 1979.
- ELI-80-6 Small-Scale Hydroelectric Policy Report for New Hampshire: Legislative Options and Recommendations (with the National Conference of State Legislatures, Denver, Colorado) 1980.
- ELI-80-7 Legislative Options and Recommendations for Facilitating Hydroelectric Development in North Carolina, 1980.
- ELI-79-44 Recommended Legislative Options for Improving Hydroelectric Development in Washington, 1979.
- ELI-80-3 Montana Small-Scale Hydroelectric Development Policy Report: Legislative Issues and Options (with the National Conference of State Legislatures, Denver, Colorado) 1980.
- ELI-80-4 Hawaii Small-Scale Hydroelectric Development Policy Report: Preliminary Legislative Issues and Options (with the National Conference of State Legislatures, Denver, Colorado) 1980.

ELI-80-5 Small-Scale Hydroelectric Policy Report for Pennsylvania:
Preliminary Issues and Options (with the National Conference of
State Legislatures, Denver, Colorado) 1980.

APPENDIX I

FORMS

Included here are extra copies of forms that may prove useful to the microhydropower developer.

- Daily electrical load requirements
- Flow measurement table
- Microhydropower turbine-generator information request
- Microhydropower detailed cost estimate.

Appliances or equipment	Watts	Hourly load schedule (Noon)																							
		1	2	3	4	5	6	7	8	9	10	11	12	1	2	3	4	5	6	7	8	9	10	11	12
Total hourly load in kW (W ÷ 1000)																									

I-1

Appliances or equipment	Watts	Hourly load schedule																							
		(Noon)																							
		1	2	3	4	5	6	7	8	9	10	11	12	1	2	3	4	5	6	7	8	9	10	11	12
Total hourly load in kW (W ÷ 1000)		/ /																							

I-4

FLOW MEASUREMENT TABLE

Date	Time	Reading (time or depth)	Conversion factor	Computed flow, Q ₁ (cfs)	Gage flow, Q ₂ (cfs)	Correlation, $\frac{Q_1}{Q_2}$

I-6

FLOW MEASUREMENT TABLE

Date	Time	Reading (time or depth)	Conversion factor	Computed flow, Q_1 (cfs)	Gage flow, Q_2 (cfs)	Correlation, $\frac{Q_1}{Q_2}$

I-1

FLOW MEASUREMENT TABLE

Date	Time	Reading (time or depth)	Conversion factor	Computed flow, Q_1 (cfs)	Gage flow, Q_2 (cfs)	Correlation, $\frac{Q_1}{Q_2}$

8-1

FLOW MEASUREMENT TABLE

Date	Time	Reading (time or depth)	Conversion factor	Computed flow, Q_1 (cfs)	Gage flow, Q_2 (cfs)	Correlation, $\frac{Q_1}{Q_2}$

6-1

FLOW MEASUREMENT TABLE

Date	Time	Reading (time or depth)	Conversion factor	Computed flow, Q_1 (cfs)	Gage flow, Q_2 (cfs)	Correlation, $\frac{Q_1}{Q_2}$

I-10

MICROHYDROPOWER TURBINE GENERATOR
INFORMATION REQUEST

(DATE)

GENTLEMEN:

I am interested in installing a microhydropower system. The following site specifications are supplied for your evaluation. Please review the specifications and answer any appropriate questions concerning your equipment.

My Name: _____
Phone No. () _____
Project Name: _____

Address: _____

I. REASON FOR DEVELOPMENT

(Check One)

- ___ 1. I am interested in supplying my own electrical needs. I do not plan to intertie with a utility. Therefore, I will require a synchronous generator.
- ___ 2. I am interested in supplying my own electrical needs. When my needs are less than the energy produced, I would consider selling to a utility. However, I want to be able to generate power independent of a utility. I therefore require a synchronous generator and speed control equipment.
- ___ 3. I am interested in supplying my own electrical needs. I want to be able to sell excess power to a utility. An induction generator is acceptable since I do not care to generate power independent of the utility.
- ___ 4. I am interested in generating as much power as possible for the dollar invested. However, I want a synchronous generator so that I can generate power if the utility service is interrupted.
- ___ 5. I am interested in generating as much electrical power as possible for the dollar invested. I am not interested in generating independent of the utility.

II. TYPE OF SOURCE AND AMOUNT OF HEAD

(Check One)

- 1. The site is a run-of-the-stream site and can have a pool-to-pool head from _____ to _____ feet.
- 2. The site is an existing dam and has a constant/variable pool-to-pool head of _____ to _____ feet.
- 3. The site is a canal drop/industrial waste discharge and has a pool-to-pool head of _____ feet.

III. AMOUNT OF FLOW

(Check One)

- 1. The flow values are based on the attached flow duration curve.
- 2. The flow value is based on a minimum stream flow of _____ cfs. This is because my objective is to supply my energy needs as much of the year as I can.
- 3. The flow is available _____ months out of the year and is fairly constant at _____ cfs.
- 4. The flow values are based on monthly averages in cfs:

Jan. _____	May _____	Sept. _____
Feb. _____	Jun. _____	Oct. _____
Mar. _____	Jul. _____	Nov. _____
Apr. _____	Aug. _____	Dec. _____
- 5. Other: See V-9, Additional Information.

IV. PERSONAL POWER NEEDS

A copy of the daily load use table is attached. The daily peak load is estimated to be _____ kW. Major electrical equipment is listed below.

_____	_____
_____	_____
_____	_____
_____	_____
_____	_____

The voltage I need is _____, and is single/three phase.

V. ADDITIONAL INFORMATION

1. Site location and stream name _____

2. Name of local utility _____
Distance to nearest substation is _____ miles.
3. The quality of the water is usually clear/murky/silt laden/muddy.
4. Site elevation is _____ feet.
5. Annual average temperature variation is from _____
to _____ °F.
6. A sketch of the site is/is not included.
7. Existing structures or equipment that should be used, if
possible, include _____

8. The proposed diameter and length of the penstock are (leave blank
if not known): _____ inches in diameter, _____ feet in
length.
9. Additional information to be considered _____

(TO BE COMPLETED BY MANUFACTURER/SUPPLIER)

Name of Company _____
Address _____

Phone No. () _____ Date _____

I. GENERAL COMMENTS _____

II. RECOMMENDED EQUIPMENT SUPPLIED BY COMPANY

1. Turbine Inlet Gate or Valve

Manufacturer _____
Type _____
Model No. _____

2. Turbine

Manufacturer _____
Type _____
Model No. _____

3. Generator

Manufacturer _____
Type _____
Model No. _____

4. Is load diverter/governor included? Yes/No.

Yes: Type _____
Model No. _____
No: Type recommended _____
Model No. _____

5. Additional items supplied with package, e.g. transformer, protection devices, auxiliary equipment. Provide manufacturer, dimensions, operating characteristics

III. EQUIPMENT SPECIFICATION

For a net effective head at the turbine of _____ feet and a flow of _____ cfs, the generator will provide an output of _____ kW (assumed power factor of _____). This will result in a computed efficiency of _____%. Based on the information provided, the annual energy production is calculated to be _____ kWh.

1. Turbine:

_____ rpm at recommended head and flow.
Diameter of runner _____ and type _____.

2. Generator:

Operating rpm _____.
Overspeed allowance _____%
Voltage _____ single/three phase.
Rating _____ single/three phase.
Power factor _____

3. Speed increaser

Type _____
Ratio _____
Rated input horsepower _____
Service factor _____

4. Draft tube, if used:

Length _____
Elevation from turbine runner centerline to tailwater at lowest water level _____
Outlet area _____
Inlet diameter _____

5. Is unit assembled on equipment frame? Yes/No

Yes: Dimensions of frame _____

6. Recommended powerhouse minimum dimensions:

Length _____ ft
Width _____ ft
Height _____ ft.

7. Weight of assembled unit _____ lb
Shipping weight _____ lb
Wetted weight _____ lb
Recommended mass of equipment pad _____ lb.

8. Is shutoff valve or gate provided ahead of turbine? Yes/No

No: Recommended size _____
Type _____
Manufacturer _____.

9. Recommended spare turbine-generator parts

10. Expected operating life with normal maintenance and operating conditions: _____ yrs.

11. Turbine warranty provisions included? Yes/No

12. Is cooling water required for the generator, speed increaser, and/or lubrication system? Yes/No

Yes: Flow _____ at _____ temperature, _____ system
Flow _____ at _____ temperature, _____ system
Flow _____ at _____ temperature, _____ system

13. Recommended powerhouse ventilation _____ cfm.

14. With the information provided, the minimum output for the unit would be _____ kW at _____ head and _____ cfs flow. The maximum output for the unit would be _____ kW at _____ head and _____ cfs flow.

15. Diameter of turbine inlet _____ in. and outlet _____ in. or outlet dimensions _____ in. by _____ in.

16. Lightning protection is/is not provided.

IV. COST OF EQUIPMENT RECOMMENDED

(Choose Appropriate Answer(s))

1. The cost estimate is/is not based on a complete unit cost.
2. The cost delivered to the site is _____.
Bid is/is not attached.
3. On the basis of information provided, the cost of the equipment recommended should approach _____ delivered to the site.
(This is not a bid.)
4. The cost estimates are good until _____.

V. ADDITIONAL INFORMATION

1. Recommended material and equipment not furnished by company.

Penstock: Size _____ Material _____

Valves _____

Electrical equipment _____

Additional items _____

2. Delivery time for packages _____

3. Recommended design considerations _____

4. Additional services provided by Company (i.e., financing, complete design, installations, etc.).

5. Specific Comments _____

6. Please provide a list of three or four developers with addresses who have installed and operated your units.

_____	_____
_____	_____
_____	_____
_____	_____
_____	_____

MICROHYDROPOWER TURBINE GENERATOR
INFORMATION REQUEST

(DATE)

GENTLEMEN:

I am interested in installing a microhydropower system. The following site specifications are supplied for your evaluation. Please review the specifications and answer any appropriate questions concerning your equipment.

My Name: _____ Address: _____
Phone No. () _____
Project Name: _____

I. REASON FOR DEVELOPMENT

(Check One)

- ___ 1. I am interested in supplying my own electrical needs. I do not plan to intertie with a utility. Therefore, I will require a synchronous generator.
- ___ 2. I am interested in supplying my own electrical needs. When my needs are less than the energy produced, I would consider selling to a utility. However, I want to be able to generate power independent of a utility. I therefore require a synchronous generator and speed control equipment.
- ___ 3. I am interested in supplying my own electrical needs. I want to be able to sell excess power to a utility. An induction generator is acceptable since I do not care to generate power independent of the utility.
- ___ 4. I am interested in generating as much power as possible for the dollar invested. However, I want a synchronous generator so that I can generate power if the utility service is interrupted.
- ___ 5. I am interested in generating as much electrical power as possible for the dollar invested. I am not interested in generating independent of the utility.

II. TYPE OF SOURCE AND AMOUNT OF HEAD

(Check One)

- 1. The site is a run-of-the-stream site and can have a pool-to-pool head from _____ to _____ feet.
- 2. The site is an existing dam and has a constant/variable pool-to-pool head of _____ to _____ feet.
- 3. The site is a canal drop/industrial waste discharge and has a pool-to-pool head of _____ feet.

III. AMOUNT OF FLOW

(Check One)

- 1. The flow values are based on the attached flow duration curve.
- 2. The flow value is based on a minimum stream flow of _____ cfs. This is because my objective is to supply my energy needs as much of the year as I can.
- 3. The flow is available _____ months out of the year and is fairly constant at _____ cfs.

4. The flow values are based on monthly averages in cfs:

Jan. _____	May _____	Sept. _____
Feb. _____	Jun. _____	Oct. _____
Mar. _____	Jul. _____	Nov. _____
Apr. _____	Aug. _____	Dec. _____

5. Other: See V-9, Additional Information.

IV. PERSONAL POWER NEEDS

A copy of the daily load use table is attached. The daily peak load is estimated to be _____ kW. Major electrical equipment is listed below.

_____	_____
_____	_____
_____	_____
_____	_____
_____	_____

The voltage I need is _____, and is single/three phase.

V. ADDITIONAL INFORMATION

1. Site location and stream name _____

2. Name of local utility _____
Distance to nearest substation is _____ miles.
3. The quality of the water is usually clear/murky/silt laden/muddy.
4. Site elevation is _____ feet.
5. Annual average temperature variation is from _____
to _____ °F.
6. A sketch of the site is/is not included.
7. Existing structures or equipment that should be used, if
possible, include _____

8. The proposed diameter and length of the penstock are (leave blank
if not known): _____ inches in diameter, _____ feet in
length.
9. Additional information to be considered _____

(TO BE COMPLETED BY MANUFACTURER/SUPPLIER)

Name of Company _____

Address _____

Phone No. () _____ Date _____

I. GENERAL COMMENTS _____

II. RECOMMENDED EQUIPMENT SUPPLIED BY COMPANY

1. Turbine Inlet Gate or Valve

Manufacturer _____

Type _____

Model No. _____

2. Turbine

Manufacturer _____

Type _____

Model No. _____

3. Generator

Manufacturer _____

Type _____

Model No. _____

4. Is load diverter/governor included? Yes/No.

Yes: Type _____

Model No. _____

No: Type recommended _____

Model No. _____

5. Additional items supplied with package, e.g. transformer, protection devices, auxiliary equipment. Provide manufacturer, dimensions, operating characteristics

III. EQUIPMENT SPECIFICATION

For a net effective head at the turbine of _____ feet and a flow of _____ cfs, the generator will provide an output of _____ kW (assumed power factor of _____). This will result in a computed efficiency of _____%. Based on the information provided, the annual energy production is calculated to be _____ kWh.

1. Turbine:

_____ rpm at recommended head and flow.
Diameter of runner _____ and type _____.

2. Generator:

Operating rpm _____.
Overspeed allowance _____%
Voltage _____ single/three phase.
Rating _____ single/three phase.
Power factor _____

3. Speed increaser

Type _____
Ratio _____
Rated input horsepower _____
Service factor _____

4. Draft tube, if used:

Length _____
Elevation from turbine runner centerline to tailwater at lowest water level _____
Outlet area _____
Inlet diameter _____

5. Is unit assembled on equipment frame? Yes/No

Yes: Dimensions of frame _____

6. Recommended powerhouse minimum dimensions:

Length _____ ft
Width _____ ft
Height _____ ft.

7. Weight of assembled unit _____ lb
Shipping weight _____ lb
Wetted weight _____ lb
Recommended mass of equipment pad _____ lb.

8. Is shutoff valve or gate provided ahead of turbine? Yes/No

No: Recommended size _____
Type _____
Manufacturer _____

9. Recommended spare turbine-generator parts

10. Expected operating life with normal maintenance and operating conditions: _____ yrs.

11. Turbine warranty provisions included? Yes/No

12. Is cooling water required for the generator, speed increaser, and/or lubrication system? Yes/No

Yes: Flow _____ at _____ temperature, _____ system
Flow _____ at _____ temperature, _____ system
Flow _____ at _____ temperature, _____ system

13. Recommended powerhouse ventilation _____ cfm.

14. With the information provided, the minimum output for the unit would be _____ kW at _____ head and _____ cfs flow. The maximum output for the unit would be _____ kW at _____ head and _____ cfs flow.

15. Diameter of turbine inlet _____ in. and outlet _____ in. or outlet dimensions _____ in. by _____ in.

16. Lightning protection is/is not provided.

IV. COST OF EQUIPMENT RECOMMENDED

(Choose Appropriate Answer(s))

1. The cost estimate is/is not based on a complete unit cost.
2. The cost delivered to the site is _____.
Bid is/is not attached.
3. On the basis of information provided, the cost of the equipment recommended should approach _____ delivered to the site.
(This is not a bid.)
4. The cost estimates are good until _____.

V. ADDITIONAL INFORMATION

1. Recommended material and equipment not furnished by company.

Penstock: Size _____ Material _____
Valves _____
Electrical equipment _____
Additional items _____

2. Delivery time for packages _____

3. Recommended design considerations _____

4. Additional services provided by Company (i.e., financing, complete design, installations, etc.).

5. Specific Comments _____

6. Please provide a list of three or four developers with addresses who have installed and operated your units.

_____	_____
_____	_____
_____	_____
_____	_____
_____	_____

MICROHYDROPOWER TURBINE GENERATOR
INFORMATION REQUEST

(DATE)

GENTLEMEN:

I am interested in installing a microhydropower system. The following site specifications are supplied for your evaluation. Please review the specifications and answer any appropriate questions concerning your equipment.

My Name: _____
Phone No. () _____
Project Name: _____

Address: _____

I. REASON FOR DEVELOPMENT

(Check One)

- ___ 1. I am interested in supplying my own electrical needs. I do not plan to intertie with a utility. Therefore, I will require a synchronous generator.
- ___ 2. I am interested in supplying my own electrical needs. When my needs are less than the energy produced, I would consider selling to a utility. However, I want to be able to generate power independent of a utility. I therefore require a synchronous generator and speed control equipment.
- ___ 3. I am interested in supplying my own electrical needs. I want to be able to sell excess power to a utility. An induction generator is acceptable since I do not care to generate power independent of the utility.
- ___ 4. I am interested in generating as much power as possible for the dollar invested. However, I want a synchronous generator so that I can generate power if the utility service is interrupted.
- ___ 5. I am interested in generating as much electrical power as possible for the dollar invested. I am not interested in generating independent of the utility.

II. TYPE OF SOURCE AND AMOUNT OF HEAD

(Check One)

- 1. The site is a run-of-the-stream site and can have a pool-to-pool head from _____ to _____ feet.
- 2. The site is an existing dam and has a constant/variable pool-to-pool head of _____ to _____ feet.
- 3. The site is a canal drop/industrial waste discharge and has a pool-to-pool head of _____ feet.

III. AMOUNT OF FLOW

(Check One)

- 1. The flow values are based on the attached flow duration curve.
- 2. The flow value is based on a minimum stream flow of _____ cfs. This is because my objective is to supply my energy needs as much of the year as I can.
- 3. The flow is available _____ months out of the year and is fairly constant at _____ cfs.
- 4. The flow values are based on monthly averages in cfs:

Jan. _____	May _____	Sept. _____
Feb. _____	Jun. _____	Oct. _____
Mar. _____	Jul. _____	Nov. _____
Apr. _____	Aug. _____	Dec. _____

- 5. Other: See V-9, Additional Information.

IV. PERSONAL POWER NEEDS

A copy of the daily load use table is attached. The daily peak load is estimated to be _____ kW. Major electrical equipment is listed below.

_____	_____
_____	_____
_____	_____
_____	_____
_____	_____
_____	_____

The voltage I need is _____, and is single/three phase.

V. ADDITIONAL INFORMATION

1. Site location and stream name _____

2. Name of local utility _____
Distance to nearest substation is _____ miles.
3. The quality of the water is usually clear/murky/silt laden/muddy.
4. Site elevation is _____ feet.
5. Annual average temperature variation is from _____
to _____ °F.
6. A sketch of the site is/is not included.
7. Existing structures or equipment that should be used, if
possible, include _____

8. The proposed diameter and length of the penstock are (leave blank
if not known): _____ inches in diameter, _____ feet in
length.
9. Additional information to be considered _____

(TO BE COMPLETED BY MANUFACTURER/SUPPLIER)

Name of Company _____
Address _____

Phone No. () _____ Date _____

I. GENERAL COMMENTS _____

II. RECOMMENDED EQUIPMENT SUPPLIED BY COMPANY

1. Turbine Inlet Gate or Valve

Manufacturer _____
Type _____
Model No. _____

2. Turbine

Manufacturer _____
Type _____
Model No. _____

3. Generator

Manufacturer _____
Type _____
Model No. _____

4. Is load diverter/governor included? Yes/No.

Yes: Type _____
Model No. _____
No: Type recommended _____
Model No. _____

5. Additional items supplied with package, e.g. transformer, protection devices, auxiliary equipment. Provide manufacturer, dimensions, operating characteristics

III. EQUIPMENT SPECIFICATION

For a net effective head at the turbine of _____ feet and a flow of _____ cfs, the generator will provide an output of _____ kW (assumed power factor of _____). This will result in a computed efficiency of ____%. Based on the information provided, the annual energy production is calculated to be _____ kWh.

1. Turbine:

_____ rpm at recommended head and flow.
Diameter of runner _____ and type _____.

2. Generator:

Operating rpm _____.
Overspeed allowance _____%
Voltage _____ single/three phase.
Rating _____ single/three phase.
Power factor _____

3. Speed increaser

Type _____
Ratio _____
Rated input horsepower _____
Service factor _____

4. Draft tube, if used:

Length _____
Elevation from turbine runner centerline to tailwater at lowest water level _____
Outlet area _____
Inlet diameter _____

5. Is unit assembled on equipment frame? Yes/No

Yes: Dimensions of frame _____

6. Recommended powerhouse minimum dimensions:

Length _____ ft
Width _____ ft
Height _____ ft.

7. Weight of assembled unit _____ lb
Shipping weight _____ lb
Wetted weight _____ lb
Recommended mass of equipment pad _____ lb.

8. Is shutoff valve or gate provided ahead of turbine? Yes/No

No: Recommended size _____
Type _____
Manufacturer _____.

9. Recommended spare turbine-generator parts

10. Expected operating life with normal maintenance and operating conditions: _____ yrs.

11. Turbine warranty provisions included? Yes/No

12. Is cooling water required for the generator, speed increaser, and/or lubrication system? Yes/No

Yes: Flow _____ at _____ temperature, _____ system
Flow _____ at _____ temperature, _____ system
Flow _____ at _____ temperature, _____ system

13. Recommended powerhouse ventilation _____ cfm.

14. With the information provided, the minimum output for the unit would be _____ kW at _____ head and _____ cfs flow. The maximum output for the unit would be _____ kW at _____ head and _____ cfs flow.

15. Diameter of turbine inlet _____ in. and outlet _____ in. or outlet dimensions _____ in. by _____ in.

16. Lightning protection is/is not provided.

IV. COST OF EQUIPMENT RECOMMENDED

(Choose Appropriate Answer(s))

1. The cost estimate is/is not based on a complete unit cost.
2. The cost delivered to the site is _____.
Bid is/is not attached.
3. On the basis of information provided, the cost of the equipment recommended should approach _____ delivered to the site.
(This is not a bid.)
4. The cost estimates are good until _____.

V. ADDITIONAL INFORMATION

1. Recommended material and equipment not furnished by company.

Penstock: Size _____ Material _____

Valves _____

Electrical equipment _____

Additional items _____

2. Delivery time for packages _____

3. Recommended design considerations _____

4. Additional services provided by Company (i.e., financing, complete design, installations, etc.).

5. Specific Comments _____

6. Please provide a list of three or four developers with addresses who have installed and operated your units.

MICROHYDROPOWER TURBINE GENERATOR
INFORMATION REQUEST

(DATE)

GENTLEMEN:

I am interested in installing a microhydropower system. The following site specifications are supplied for your evaluation. Please review the specifications and answer any appropriate questions concerning your equipment.

My Name: _____
Phone No. () _____
Project Name: _____

Address: _____

I. REASON FOR DEVELOPMENT

(Check One)

- ___ 1. I am interested in supplying my own electrical needs. I do not plan to intertie with a utility. Therefore, I will require a synchronous generator.
- ___ 2. I am interested in supplying my own electrical needs. When my needs are less than the energy produced, I would consider selling to a utility. However, I want to be able to generate power independent of a utility. I therefore require a synchronous generator and speed control equipment.
- ___ 3. I am interested in supplying my own electrical needs. I want to be able to sell excess power to a utility. An induction generator is acceptable since I do not care to generate power independent of the utility.
- ___ 4. I am interested in generating as much power as possible for the dollar invested. However, I want a synchronous generator so that I can generate power if the utility service is interrupted.
- ___ 5. I am interested in generating as much electrical power as possible for the dollar invested. I am not interested in generating independent of the utility.

II. TYPE OF SOURCE AND AMOUNT OF HEAD

(Check One)

- 1. The site is a run-of-the-stream site and can have a pool-to-pool head from _____ to _____ feet.
- 2. The site is an existing dam and has a constant/variable pool-to-pool head of _____ to _____ feet.
- 3. The site is a canal drop/industrial waste discharge and has a pool-to-pool head of _____ feet.

III. AMOUNT OF FLOW

(Check One)

- 1. The flow values are based on the attached flow duration curve.
- 2. The flow value is based on a minimum stream flow of _____ cfs. This is because my objective is to supply my energy needs as much of the year as I can.
- 3. The flow is available _____ months out of the year and is fairly constant at _____ cfs.
- 4. The flow values are based on monthly averages in cfs:

Jan. _____	May _____	Sept. _____
Feb. _____	Jun. _____	Oct. _____
Mar. _____	Jul. _____	Nov. _____
Apr. _____	Aug. _____	Dec. _____

- 5. Other: See V-9, Additional Information.

IV. PERSONAL POWER NEEDS

A copy of the daily load use table is attached. The daily peak load is estimated to be _____ kW. Major electrical equipment is listed below.

_____	_____
_____	_____
_____	_____
_____	_____
_____	_____

The voltage I need is _____, and is single/three phase.

V. ADDITIONAL INFORMATION

1. Site location and stream name _____

2. Name of local utility _____
Distance to nearest substation is _____ miles.
3. The quality of the water is usually clear/murky/silt laden/muddy.
4. Site elevation is _____ feet.
5. Annual average temperature variation is from _____
to _____ °F.
6. A sketch of the site is/is not included.
7. Existing structures or equipment that should be used, if
possible, include _____

8. The proposed diameter and length of the penstock are (leave blank
if not known): _____ inches in diameter, _____ feet in
length.
9. Additional information to be considered _____

(TO BE COMPLETED BY MANUFACTURER/SUPPLIER)

Name of Company _____
Address _____

Phone No. () _____ Date _____

I. GENERAL COMMENTS _____

II. RECOMMENDED EQUIPMENT SUPPLIED BY COMPANY

1. Turbine Inlet Gate or Valve

Manufacturer _____
Type _____
Model No. _____

2. Turbine

Manufacturer _____
Type _____
Model No. _____

3. Generator

Manufacturer _____
Type _____
Model No. _____

4. Is load diverter/governor included? Yes/No.

Yes: Type _____
Model No. _____
No: Type recommended _____
Model No. _____

5. Additional items supplied with package, e.g. transformer, protection devices, auxiliary equipment. Provide manufacturer, dimensions, operating characteristics

III. EQUIPMENT SPECIFICATION

For a net effective head at the turbine of _____ feet and a flow of _____ cfs, the generator will provide an output of _____ kW (assumed power factor of _____). This will result in a computed efficiency of _____%. Based on the information provided, the annual energy production is calculated to be _____ kWh.

1. Turbine:

_____ rpm at recommended head and flow.
Diameter of runner _____ and type _____.

2. Generator:

Operating rpm _____.
Overspeed allowance _____%
Voltage _____ single/three phase.
Rating _____ single/three phase.
Power factor _____

3. Speed increaser

Type _____
Ratio _____
Rated input horsepower _____
Service factor _____

4. Draft tube, if used:

Length _____
Elevation from turbine runner centerline to tailwater at lowest water level _____
Outlet area _____
Inlet diameter _____

5. Is unit assembled on equipment frame? Yes/No

Yes: Dimensions of frame _____

6. Recommended powerhouse minimum dimensions:

Length _____ ft
Width _____ ft
Height _____ ft.

7. Weight of assembled unit _____ lb
Shipping weight _____ lb
Wetted weight _____ lb
Recommended mass of equipment pad _____ lb.

8. Is shutoff valve or gate provided ahead of turbine? Yes/No

No: Recommended size _____
Type _____
Manufacturer _____.

9. Recommended spare turbine-generator parts

10. Expected operating life with normal maintenance and operating conditions: _____ yrs.

11. Turbine warranty provisions included? Yes/No

12. Is cooling water required for the generator, speed increaser, and/or lubrication system? Yes/No

Yes: Flow _____ at _____ temperature, _____ system
Flow _____ at _____ temperature, _____ system
Flow _____ at _____ temperature, _____ system

13. Recommended powerhouse ventilation _____ cfm.

14. With the information provided, the minimum output for the unit would be _____ kW at _____ head and _____ cfs flow. The maximum output for the unit would be _____ kW at _____ head and _____ cfs flow.

15. Diameter of turbine inlet _____ in. and outlet _____ in. or outlet dimensions _____ in. by _____ in.

16. Lightning protection is/is not provided.

IV. COST OF EQUIPMENT RECOMMENDED

(Choose Appropriate Answer(s))

1. The cost estimate is/is not based on a complete unit cost.
2. The cost delivered to the site is _____.
Bid is/is not attached.
3. On the basis of information provided, the cost of the equipment recommended should approach _____ delivered to the site.
(This is not a bid.)
4. The cost estimates are good until _____.

V. ADDITIONAL INFORMATION

1. Recommended material and equipment not furnished by company.

Penstock: Size _____ Material _____

Valves _____

Electrical equipment _____

Additional items _____

2. Delivery time for packages _____

3. Recommended design considerations _____

4. Additional services provided by Company (i.e., financing, complete design, installations, etc.).

5. Specific Comments _____

6. Please provide a list of three or four developers with addresses who have installed and operated your units.

MICROHYDROPOWER TURBINE GENERATOR
INFORMATION REQUEST

(DATE)

GENTLEMEN:

I am interested in installing a microhydropower system. The following site specifications are supplied for your evaluation. Please review the specifications and answer any appropriate questions concerning your equipment.

My Name: _____
Phone No. () _____
Project Name: _____

Address: _____

I. REASON FOR DEVELOPMENT

(Check One)

- ___ 1. I am interested in supplying my own electrical needs. I do not plan to intertie with a utility. Therefore, I will require a synchronous generator.
- ___ 2. I am interested in supplying my own electrical needs. When my needs are less than the energy produced, I would consider selling to a utility. However, I want to be able to generate power independent of a utility. I therefore require a synchronous generator and speed control equipment.
- ___ 3. I am interested in supplying my own electrical needs. I want to be able to sell excess power to a utility. An induction generator is acceptable since I do not care to generate power independent of the utility.
- ___ 4. I am interested in generating as much power as possible for the dollar invested. However, I want a synchronous generator so that I can generate power if the utility service is interrupted.
- ___ 5. I am interested in generating as much electrical power as possible for the dollar invested. I am not interested in generating independent of the utility.

II. TYPE OF SOURCE AND AMOUNT OF HEAD

(Check One)

- 1. The site is a run-of-the-stream site and can have a pool-to-pool head from _____ to _____ feet.
- 2. The site is an existing dam and has a constant/variable pool-to-pool head of _____ to _____ feet.
- 3. The site is a canal drop/industrial waste discharge and has a pool-to-pool head of _____ feet.

III. AMOUNT OF FLOW

(Check One)

- 1. The flow values are based on the attached flow duration curve.
- 2. The flow value is based on a minimum stream flow of _____ cfs. This is because my objective is to supply my energy needs as much of the year as I can.
- 3. The flow is available _____ months out of the year and is fairly constant at _____ cfs.
- 4. The flow values are based on monthly averages in cfs:

Jan. _____	May _____	Sept. _____
Feb. _____	Jun. _____	Oct. _____
Mar. _____	Jul. _____	Nov. _____
Apr. _____	Aug. _____	Dec. _____

- 5. Other: See V-9, Additional Information.

IV. PERSONAL POWER NEEDS

A copy of the daily load use table is attached. The daily peak load is estimated to be _____ kW. Major electrical equipment is listed below.

_____	_____
_____	_____
_____	_____
_____	_____
_____	_____

The voltage I need is _____, and is single/three phase.

V. ADDITIONAL INFORMATION

1. Site location and stream name _____

2. Name of local utility _____
Distance to nearest substation is _____ miles.
3. The quality of the water is usually clear/murky/silt laden/muddy.
4. Site elevation is _____ feet.
5. Annual average temperature variation is from _____
to _____ °F.
6. A sketch of the site is/is not included.
7. Existing structures or equipment that should be used, if
possible, include _____

8. The proposed diameter and length of the penstock are (leave blank
if not known): _____ inches in diameter, _____ feet in
length.
9. Additional information to be considered _____

(TO BE COMPLETED BY MANUFACTURER/SUPPLIER)

Name of Company _____
Address _____

Phone No. () _____ Date _____

I. GENERAL COMMENTS _____

II. RECOMMENDED EQUIPMENT SUPPLIED BY COMPANY

1. Turbine Inlet Gate or Valve

Manufacturer _____
Type _____
Model No. _____

2. Turbine

Manufacturer _____
Type _____
Model No. _____

3. Generator

Manufacturer _____
Type _____
Model No. _____

4. Is load diverter/governor included? Yes/No.

Yes: Type _____
Model No. _____

No: Type recommended _____
Model No. _____

5. Additional items supplied with package, e.g. transformer, protection devices, auxiliary equipment. Provide manufacturer, dimensions, operating characteristics

III. EQUIPMENT SPECIFICATION

For a net effective head at the turbine of _____ feet and a flow of _____ cfs, the generator will provide an output of _____ kW (assumed power factor of _____). This will result in a computed efficiency of _____%. Based on the information provided, the annual energy production is calculated to be _____ kWh.

1. Turbine:

_____ rpm at recommended head and flow.
Diameter of runner _____ and type _____.

2. Generator:

Operating rpm _____.
Overspeed allowance _____%
Voltage _____ single/three phase.
Rating _____ single/three phase.
Power factor _____

3. Speed increaser

Type _____
Ratio _____
Rated input horsepower _____
Service factor _____

4. Draft tube, if used:

Length _____
Elevation from turbine runner centerline to tailwater at lowest water level _____
Outlet area _____
Inlet diameter _____

5. Is unit assembled on equipment frame? Yes/No

Yes: Dimensions of frame _____

6. Recommended powerhouse minimum dimensions:

Length _____ ft
Width _____ ft
Height _____ ft.

7. Weight of assembled unit _____ lb
Shipping weight _____ lb
Wetted weight _____ lb
Recommended mass of equipment pad _____ lb.

8. Is shutoff valve or gate provided ahead of turbine? Yes/No

No: Recommended size _____
Type _____
Manufacturer _____.

9. Recommended spare turbine-generator parts

10. Expected operating life with normal maintenance and operating conditions: _____ yrs.

11. Turbine warranty provisions included? Yes/No

12. Is cooling water required for the generator, speed increaser, and/or lubrication system? Yes/No

Yes: Flow _____ at _____ temperature, _____ system
Flow _____ at _____ temperature, _____ system
Flow _____ at _____ temperature, _____ system

13. Recommended powerhouse ventilation _____ cfm.

14. With the information provided, the minimum output for the unit would be _____ kW at _____ head and _____ cfs flow. The maximum output for the unit would be _____ kW at _____ head and _____ cfs flow.

15. Diameter of turbine inlet _____ in. and outlet _____ in. or outlet dimensions _____ in. by _____ in.

16. Lightning protection is/is not provided.

IV. COST OF EQUIPMENT RECOMMENDED

(Choose Appropriate Answer(s))

1. The cost estimate is/is not based on a complete unit cost.
2. The cost delivered to the site is _____.
Bid is/is not attached.
3. On the basis of information provided, the cost of the equipment recommended should approach _____ delivered to the site.
(This is not a bid.)
4. The cost estimates are good until _____.

V. ADDITIONAL INFORMATION

1. Recommended material and equipment not furnished by company.

Penstock: Size _____ Material _____
Valves _____
Electrical equipment _____
Additional items _____

2. Delivery time for packages _____

3. Recommended design considerations _____

4. Additional services provided by Company (i.e., financing, complete design, installations, etc.).

5. Specific Comments _____

6. Please provide a list of three or four developers with addresses who have installed and operated your units.

_____	_____
_____	_____
_____	_____
_____	_____
_____	_____

Microhydropower

Detailed Cost Estimate

Date _____

Page _____ of _____

Prep. By _____

Description	Material Quantity & Units	Mat'l Unit Cost	Unit Labor Hours	Total Labor Hours	Labor Rate	Labor Cost	Material Cost	Other Cost	Total Cost

I-46

Microhydropower

Detailed Cost Estimate

Date _____

Page _____ of _____

Prep. By _____

Description	Material Quantity & Units	Mat'l Unit Cost	Unit Labor Hours	Total Labor Hours	Labor Rate	Labor Cost	Material Cost	Other Cost	Total Cost

I-47

Microhydropower

Detailed Cost Estimate

Date _____

Page _____ of _____

Prep. By _____

Description	Material Quantity & Units	Mat'l Unit Cost	Unit Labor Hours	Total Labor Hours	Labor Rate	Labor Cost	Material Cost	Other Cost	Total Cost

I-48

Microhydropower

Detailed Cost Estimate

Date _____

Page _____ of _____

Prep. By _____

Description	Material Quantity & Units	Mat'l Unit Cost	Unit Labor Hours	Total Labor Hours	Labor Rate	Labor Cost	Material Cost	Other Cost	Total Cost

I-49

Microhydropower

Detailed Cost Estimate

Date _____

Page _____ of _____

Prep. By _____

Description	Material Quantity & Units	Mat'l Unit Cost	Unit Labor Hours	Total Labor Hours	Labor Rate	Labor Cost	Material Cost	Other Cost	Total Cost

I-50

U S GOVERNMENT PRINTING OFFICE 1983:6-46-069 6 9

INEL 2 2412