

THE No 1 UK MAGAZINE FOR ELECTRONICS TECHNOLOGY & COMPUTER PROJECTS

# EPE EVERYDAY PRACTICAL ELECTRONICS

www.epemag.com

## LOW-CAPACITANCE ADAPTOR FOR DMMs

- Measure to sub-picofarad capacitance values
- Works with standard digital multimeters
- Probe for detecting stray capacitance

## STEREO COMPRESSOR

Reduces dynamic sound levels for comfortable listening



## 3-INPUT STEREO AUDIO SWITCHER

Add extra analogue inputs for your stereo or home theatre

## Jump Start



## iPod Speaker

Easy-to-build, low-cost and portable



## Raspberry Pi

Display and keypad interface



WIN A  
MICROCHIP  
MPLAB REAL  
ICE probe kit  
RRP £315

JAN 2013 £4.40



9 770262 361188

**FREE DELIVERY**  
On All Orders\*

**No Minimum Order Necessary!**

\*Only valid on orders delivered within the UK. Expires 01/02/2013. E&OE.

FREE DELIVERY CODE...

**'EPETCNE'**

To claim your free delivery, simply enter the coupon code when processing your order at checkout stage.

Contains  
**4500+**  
Electronic  
Components  
& Projects



**NEW**  
**CATALOGUE**

To order your **FREE** copy of the Spiratronics catalogue, simply visit our website and click on the catalogue link on our homepage. Or alternatively, give us a ring on 01733 212048.



visit us at...  
**spiratronics.com**  
for our comprehensive range

- \* Thousands of low cost, high quality products
- \* Same day dispatch on orders before 3pm
- \* Low, flat postage cost (£1.49 for UK) on all orders with no minimum order value

 **Spiratronics**

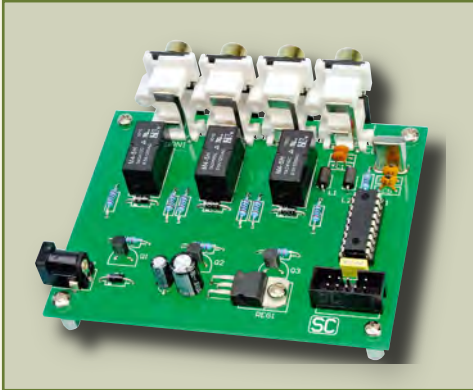

## Projects and Circuits

### 3-INPUT STEREO AUDIO SWITCHER

by John Clarke and Greg Swain

Add analogue audio inputs to your stereo amplifier or home-theatre set-up

### STEREO COMPRESSOR

by John Clarke

Reduce the dynamic range of a sound source to comfortable levels

### LOW-CAPACITANCE ADAPTOR FOR DMMs

By Jim Rowe

Use a standard digital multimeter to measure capacitance to less than a pF

### UNIVERSAL USB DATA LOGGER - PART 2

by Mauro Grassi

Assembly, software and use of the data logger

## Series and Features

### TECHNO TALK

by Mark Nelson

World of weirdness

### JUMP START

by Mike and Richard Tooley

iPod Speaker

### PIC N' MIX

by Mike Hibbett

Getting to grips with interrupts

### MAX'S COOL BEANS

by Max The Magnificent

Garage mentality... \$100 personal supercomputer

### RASPBERRY PI

by Mike Hibbett

Keypad and LCD interface

### CIRCUIT SURGERY

by Ian Bell

More notes on the Early effect

### PRACTICALLY SPEAKING

by Robert Penfold

Passive light change detector

### NET WORK

by Alan Winstanley

Hot on the trail... eBay gum!... Not netiquette... Christmas cheer

## Regulars and Services

### EDITORIAL

Looking forward and looking back... End of an era

### NEWS

Barry Fox highlights technology's leading edge

Plus everyday news from the world of electronics

### MICROCHIP READER OFFER

EPE Exclusive - Win a Microchip MPLAB REAL ICE probe kit, worth £315!

### EPE BACK ISSUES

Did you miss these?

### SUBSCRIBE TO EPE

and save money

### CD-ROMS FOR ELECTRONICS

A wide range of CD-ROMs for hobbyists, students and engineers

### DIRECT BOOK SERVICE

A wide range of technical books available by mail order, plus more CD-ROMs

### EPE PCB SERVICE

PCBs for EPE projects

### ADVERTISERS INDEX

### NEXT MONTH!

Highlights of next month's EPE

© Wimborne Publishing Ltd 2012. Copyright in all drawings, photographs and articles published in *EVERYDAY PRACTICAL ELECTRONICS* is fully protected, and reproduction or imitations in whole or in part are expressly forbidden.

Our February 2013 issue will be published on Thursday 3 January 2013, see page 80 for details.

Everyday Practical Electronics, January 2013

Readers' Services • Editorial and Advertisement Departments

7

1

**01279** Credit Card Sales **467799**

Ho! Ho! Ho! Christmas 2012 is on it's way but **DON'T PANIC!**  
We have some fantastic gift ideas for young (and older) enquiring minds

**Electronic Project Labs**  
An electronics course in a box! All assume no previous knowledge and require NO solder. See website for full details



30 in ONE Project Lab  
£17.95 (Code EPL030)



130 in ONE Project Lab  
£49.95 (Code EPL130)



300 in ONE Project Lab  
£79.95 (Code EPL300)



500 in ONE Project Lab  
£179.95 (Code EPL500)



Robot Sensor 20 Lab  
£21.95 (Code EPLR20)



Digital Recording Laboratory  
£29.95 (Code EPLDR)

**Solderless Electronic Projects**



AM-FM Radio Kit  
£9.95 (Code ERKAF)



Short Wave Kit  
£9.95 (Code ERKSW)

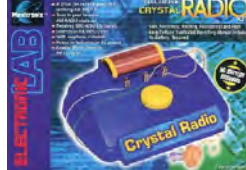

Crystal Radio Kit  
£7.95 (Code ERKC)



Electronic Bell Kit  
£6.95 (Code EAKEB)



Electronic Motor Kit  
£6.95 (Code EAKEM)



Generator Kit  
£6.95 (Code EAKEG)



Room Alarm Kit  
£4.95 (Code EAKRA)



Hand Held Metal Detector (Assembled)  
£7.95 (Code ELMDX7)



Metal Detector Kit  
£7.95 (Code ELMD)

**Mechanical Motorised Wooden Kits**  
Future engineers can learn about the operation of transmissions steered through gears or pulleys. Easy to build, no glue or soldering required.



Automech Kit  
£14.95 (Code C21-605)



Coptermech Kit  
£14.95 (Code C21-604)



Trainmech Kit  
£14.95 (Code C21-606)



Robomech Kit  
£15.95 (Code C21-603)



Tyrannomech Kit  
£14.95 (Code C21-601)

**Festive Fun Electronic Project Kits**  
Choose from 500 plus electronic kits. Soldering required.



Musical LED Jingle Bells Kit  
£21.95 (Code 1176KT)



Flashing LED Christmas Tree Kit  
£4.95 (Code MK100)



Riding Santa Kit  
£13.95 (Code MK116)



60 LED Multi-Effect LED Star Kit  
£14.95 (Code MK170)

See our website for even more great gift ideas!





Sound LED Star Kit  
£11.95 (Code MK172)



LED Roulette Kit  
£13.95 (Code MK119)

### Robot Kits

These educational electronic robot kits make a great introduction to the exciting world of robotics. Some require soldering. See website for details



Robotic Arm Kit  
£44.95 (Code C9895)



Crawling Bug Kit with Case  
£16.95 (Code MK165)



Crawling Bug Kit  
£13.95 (Code MK129)



Running Microbot Kit  
£10.95 (Code MK127)



Solar Bug Kit  
£9.95 (Code MK185)

### Tools & Equipment



Soldering Set  
£12.95 (Code SOL939)



Hobby Tool Set  
£20.95 (Code HTK300)



20 Piece Electronics Tool Set  
£34.95 (Code HTK368)



Rectangular Illuminated Bench Top Magnifier  
£74.95 (Code HTM018)



48W Digital Soldering Station  
£69.95 (Code SOL050)



Advanced Personal Scope, 2 x 240MS/s - Probes, Cables, Battery Pack, PSU & User Manual Included  
£274.95 (Code APS230)



0-30V/0-3A Regulated Bench Power Supply  
£159.95 (Code PSU676)



Hobby Test Meter  
£7.95 (Code DMM006)



Digital Clamp Meter  
£14.95 (Code DMC616)



Helping Hands Tool  
£4.95 (Code 710.165)



Universal Battery Tester  
£2.95 (Code 690.393)

### More Projects & Gadgets



Soldering Starter Pack (inc. 2 electronic kits & soldering tools)  
£23.95 (Code EDU03)



**QUASAR**  
electronics  
Get Plugged In!



Solar Energy Experimenter Kit  
£15.95 (Code EDU02)



Digital Echo Chamber Kit  
£13.95 (Code MK182)



Oscilloscope Tutor Project  
£17.95 (Code EDU06)



One Chip AM Radio Kit  
£15.95 (Code 3063KT)



Stereo Valve Amplifier Kit (Chrome Version)  
£899.95 (Code K4040)



Pocket Beta & Gamma Radioactivity Monitor  
£149.95 (Code VM200)

**Credit Card Sales**  
01279  
467  
799



MP3 Jukebox Module  
£14.95 (Code VM202)



USB Tutor Project  
£54.95 (Code EDU05)



USB 3D LED Cube Kit  
£23.95 (Code MK193)



Classic TV Tennis Game with Analogue Bats Kit  
£20.95 (Code MK191)



3 x 5 Amp RGB LED Controller (+RS232) Kit  
£29.95 (Code 8191KT)

This is a small selection from our huge range of electronic kits & projects. Please see website for full details.



[www.QuasarElectronics.co.uk](http://www.QuasarElectronics.co.uk)

Secure Online Ordering Facilities • Full Product Listing, Descriptions & Photos • Kit Documentation & Software Downloads

# Everyday Practical Electronics Featured Kits

January 2013

Everyday Practical Electronics Magazine has been publishing a series of popular kits by the acclaimed Silicon Chip Magazine Australia. These projects are 'bullet proof' and already tested Down Under. All Jaycar kits are supplied with specified board components, quality fibreglass tinned PCBs and have clear English instructions. Watch this space for future featured kits.



## Kits Featured this Month!

### Low Capacitance Adaptor for DMM Kit

Cat. KC-5493



£12.75\*

Many modern multimeters come with capacitance ranges, but they're no good for very small values. This kit is a nifty little adaptor that allows a standard digital multimeter to measure very low values of capacitance from less than one picofarad to over 10nF. It will allow you to measure tiny capacitors or stray capacitances in switches, connectors and wiring. The kit is complete with PCB, components and case. All you'll need is a 9V battery and just about any modern DMM.

- PCB: 51 x 90mm

Featured in EPE January 2013



### Stereo Compressor Kit

Cat. KC-5507

Compressors are useful in eliminating the extreme sound levels during TV ads, "pops" from microphones when people speak or bump/drop them, levelling signals when singers or guitarist vary their level, etc. Kit includes PCB, processed case and electronic components for 12VDC operation. 12VDC plug pack required -

Use MP-3147 £6.25\*

- PCB: 118 x 102mm

Featured in EPE January 2013

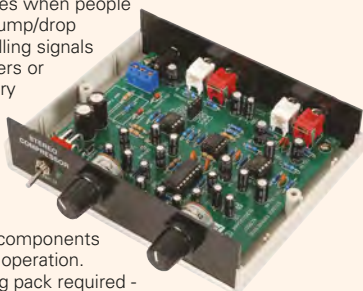

£21.75\*

### Teach Kids Electronics

Cat. KJ-8502

This full colour 96 page book has over 100 drawings and diagrams. The projects are fun to build and relevant to the electronics scene in the new millennium. Included with the book, you get the baseboard, plenty of spring terminals and ALL the components required to build every project in the book, INCLUDING the bonus projects.

- Suitable for ages: 8+
- Book size: 205mm x 275mm

£14.50\*

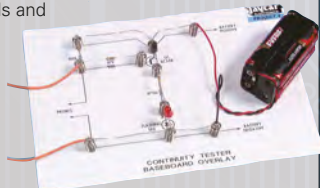

### USB Power Monitor Kit

Cat. KC-5516

Plug this kit inline with a USB device to display the current that is drawn at any given time. Check the total power draw from an unpowered hub and its attached devices or what impact a USB device has on your laptop battery life. Displays current, voltage or power, is auto-ranging and will read as low as a few microamps and up to over an amp.

Kit supplied with double sided, soldermasked and screen-printed PCB with SMD components pre-soldered, LCD screen, and components.

- PCB: 65 x 36mm

Note: Laptop not included



£21.75\*



### High-Energy Electric Ignition Kit for Cars

Cat. KC-5513

Use this kit to replace a failed ignition module or to upgrade a mechanical ignition system when restoring a vehicle. Use with virtually any ignition system that uses a single coil with points, hall effect/lumenition, retractor or optical sensors (Crane and Piranha) and ECU. Features include adjustable dwell time, output or follow input option, tachometer output, adjustable debounce period, dwell compensation for battery voltage and coil switch-off with no trigger signal.

- Kit supplied with silk-screened PCB, diecast enclosure (111 x 60 x 30mm), pre-programmed PIC and PCB mount components for four trigger/pickup options.

£18.25\*



### High Performance 250WRMS Class-D Amplifier Kit

Cat. KC-5514

High quality amplifier boasting 250WRMS output into 4 ohms, 150W into 8 ohms and can be bridged with a second kit for 450W into 8 ohms. Features include high efficiency (90% @ 4 ohm), low distortion and noise (<0.01%), and over-current, over-temperature, under-voltage, over-voltage and DC offset protection. Kit supplied with double sided, soldermasked and screen-printed silk-screened PCB with SMD IC pre-soldered, heatsink, and electronic circuit board mounted components.

- Power requirements: +/- 40 to 60VDC, 50 to 55V nominal (see KC-5471)
- S/N ratio: 103dB
- Freq. response: 10Hz - 10kHz, +/- 1dB
- PCB: 117 x 167mm

Also available:

**Stereo Speaker Protector Kit to suit NEW**

KC-5515 £11.00\*

**+/- 55V Power Supply Kit to suit KC-5471 £11.00\***



£32.75\*



### Speedo Corrector MkII Kit

Cat. KC-5435

When you modify your gearbox, diff ratio or change to a large circumference tyre, it may result in an inaccurate speedometer. This kit alters the speedometer signal up or down from 0% to 99% of the original signal. The input setup selection can be automatically selected and features an LED indicator to show when the input signal is being received. Kit supplied with PCB with overlay and all electronic components.

£20.00\*

- PCB: 105 x 61mm
- Recommended box: UB3 (use HB-6013 £1.50\*)



### Ultrasonic Antifouling Kit for Boats

Cat. KC-5498

Marine growth electronic antifouling systems can cost thousands. This project uses the same ultrasonic waveforms and virtually identical ultrasonic transducers mounted in a sturdy polyurethane housings. By building it yourself (which includes some potting) you save a fortune! Standard unit consists of control electronic kit and case, ultrasonic transducer, potting and gluing components and housings. The single transducer design of this kit is suitable for boats up to 10m (32ft; boats longer than about 14m will need two transducers and drivers. Basically all parts supplied in the project kit including wiring. Price includes epoxies.

- 12VDC
- Suitable for power or sail
- Could be powered by a solar panel/wind generator
- PCB: 104 x 78mm

Featured in EPE Sept/Oct 2012

Also Available Pre-built:

**Dual output, suitable for vessels up to 14m (45ft)**

YS-5600 was £309.25 now £292.00\* save £17.25

**Quad output, suitable for vessels up to 20m (65ft)**

YS-5602 was £412.25 now £395.25\* save £17.00



£90.50\*



YS-5600

# Jaycar

Electronics

Better, More Technical

For more details on each kit visit our website [www.jaycar.co.uk](http://www.jaycar.co.uk)

FREE CALL ORDERS: 0800 032 7241

# Audio Kits for Electronics Enthusiasts

## 45 Second Voice Recorder Kit

Cat. KC-5454

This kit easily record two, four or eight different messages for random-access playback or a single message for 'tape mode' playback. It also provides cleaner and glitch-free line-level audio output suitable for feeding an amplifier or PA system. It can be powered from any source of 9-14V DC.

- Supplied with silk screened and solder masked PCB and all electronic components
- PCB: 120 x 58mm



£12.75\*

Popular Kit!

## Theremin Synthesiser Kit MkII

Cat. KC-5475

Create your own eerie science fiction sound effects by simply moving your hand near the antenna. Easy to set up and build. Complete kit contains PCB with overlay, pre-machined case and all specified components.

- PCB: 85 x 145mm

£27.25\*



Best Seller!

## Digital Audio Delay Kit

Cat. KC-5506

Corrects sound and picture synchronization ("lip sync") between your modern TV and home theatre system. Features an adjustable

delay from 20 to 1500ms in 10ms steps, and handles Dolby Digital AC3, DTS and linear PCM audio with sampling rate of up to 48kHz. Connections include digital S/PDIF and optical Toslink connections, and digital processing means there is no audio degradation. Kit includes PCB with overlay a pre-soldered SMD IC, enclosure with machined panels, and electronic components.

- 9-12VDC power supply required
- Universal IR remote required
- PCB: 103 x 118mm

£36.25\*



## "The Champ" Audio Amplifier Kit

Cat. KC-5152

This tiny module uses the LM386 audio IC, and will deliver 0.5W into 8 ohms from a 9V supply making it ideal for all those basic audio projects. It features variable gain, will happily run from 4-12VDC and is smaller than a 9V battery, allowing it to fit into the tightest of spaces.

- PCB and electronic components included
- PCB: 46 x 26 mm

£3.00\*



## SD Card Speech Recorder/Player Kit

Cat. KC-5481

Use this kit to store your WAV files on MMC/SD/SDHC cards. It can be used as a jukebox, a sound effects player or an expandable digital voice recorder. You can use it as a free-standing recorder or in conjunction with any Windows, MAC® or Linux PC.

- Short form kit includes overlay PCB, SD card socket and electronic components
- Compatible with SD, SDHC or MMC cards
- PCB: 164 x 136mm

£27.25\*



## Ultra-Low Distortion 135WRMS Amplifier Kit

Cat. KC-5470

This ultra low distortion amplifier module uses the new ThermalTrak power transistors and is largely based on the high-performance Class-A amplifier. This improved circuit has no need for a quiescent current adjustment or a Vbe multiplier transistor and has an exceptionally low distortion figure. Kit supplied with PCB and all electronic components. Heat sink and power supply not included.

- Output Power: 135WRMS into 8 ohms and 200WRMS into 4 ohms
- Frequency Response at 1W: 4Hz to 50kHz
- Harmonic Distortion: <0.008% from 20Hz to 20kHz

Also available:  
**Power Supply Kit for Ultra-LD Mk2 200W Amplifier (KC-5470) KC-5471 £11.00\***

£34.50\*



## Crystal Radio Kit

Cat. KV-3540

Enjoy AM broadcasting without using battery or other power sources. Ideal for entry-level students or hobbyist with little electronics experience. Includes circuit explanation. Kit supplied with silk-screened PCB, crystal, prewound coil, earphone and all components.

- PCB: 81 x 53mm

£4.75\*



## "Minivox" Voice Operated Relay Kit

Cat. KC-5172

Voice operated relays are used for 'hands free' radio communications and some PA applications etc. Instead of pushing a button, this device is activated by the sound of a voice. This tiny kit fits in the tightest spaces and has almost no turn-on delay. 12VDC @ 35mA required. Kit is supplied with PCB electret mic, and all specified components.

- PCB: 47 x 44mm

£6.00\*



## The Super Ear Kit

Cat. KA-1809

This kit assists people who have difficulty in hearing high audio frequencies, or for those who want to hear more than their normal unaided ear. By amplifying these high audio frequencies, not only will conversations be made clearer, you will be able to hear noises not normally heard such as insects or a watch ticking, for example. Built into a small case and powered from a 9V battery makes this kit totally portable. Use it as a hearing aid or for a fun & educational purpose.

- Kit supplied with case, front label, PCB, 9V battery, and all electronic components.
- Headphones required
- PCB: 56 x 26mm

£10.50\*



NOTE: Not a replacement for a proper hearing aid.



NOW SHIPPING VIA DHL

• FAST DELIVERY • TRACK SHIPMENT

5-10 working day delivery

Post & Packing Charges

How to Order

Order Value	Value	Cost	
£10	£49.99	£5	✓ We ship via DHL
£50	£99.99	£10	✓ Expect 5-10 days for air parcel delivery
£100	£199.99	£20	✓ Track & Trace parcel
£200	£499.99	£30	
£500+		£40	

• Max weight 550lb  
• Heavier parcels POA  
• Minimum order £10

Note: Products are despatched from Australia, so local customs duty & taxes may apply.

WEB: [www.jaycar.co.uk](http://www.jaycar.co.uk)  
PHONE: 0800 032 7241\*  
FAX: +61 2 8832 3118\*  
EMAIL: [techstore@jaycar.co.uk](mailto:techstore@jaycar.co.uk)  
POST: P.O. Box 107, Rydalmere NSW 2116 Australia

\*Australian Eastern Standard Time (Monday - Friday 09.00 to 17.30 GMT + 10 hours)

All prices in Pounds Sterling. Prices valid until 31/1/2013

ORDER ONLINE: [www.jaycar.co.uk](http://www.jaycar.co.uk)

\*All prices EXCLUDE postage & packing

**Jaycar**  
Electronics

Better, More Technical

**UK's No 1 source for VELLEMAN® Kits**
**Kit Catalogue Available**
**Now Available - Cebek Modules**  
*All modules assembled & tested.*

**Digital Echo Chamber Kit**  
 A compact sound effects kit, with built-in mic or line in, line out or speaker (500mW). 4 Adjustment controls. Power: 9Vdc 150mA



**MK182 Velleman kit £11.43**

**Self Assembly Kits & Ready made Modules - See our web site for details on the whole range, Data sheets, Software and more.**  
**www.esr.co.uk**

**Digital Record/Player**  
 Non volatile flash memory, Single 20 sec recording via integral mic, 2W output to 8Ω speaker. Power: 5Vdc 100mA.



**C-9701 Cebek Module £7.89**

**3rd Brake Light Flasher Kit**  
 Works with any incandescent or LED rear centre brake light. Flashes at 7Hz for 5 or 10 times, adjustable re-triggering. Power: 12Vdc max load 4A



**MK178 Velleman kit £6.30**

**Multifunction Up/Down Counter**  
 An up or down counter via on-board button or ext input. Time display feature. Alarm count output. 0-9999 display. Power: 9-12Vdc 150mA



**K8035 Velleman kit £17.85**

**2 Digital Counter**  
 Standard counter, 0 to 99 from input pulses or external signal. With reset input, 13.5mm Displays. Power: 12Vdc 90mA.



**CD-9 Cebek Module £12.99**

**Digital Clock Mini Kit**  
 Red 7 Segment display in attractive enclosure, automatic time base selection, battery back-up, 12 or 24Hr modes. Power: 9Vac or dc



**MK151 Velleman kit £15.09**

**Nixie Clock Kit**  
 Gas filled nixie tubes with their distinctive orange glow. HH:MM display, automatic power sync 50/60Hz. Power: 9-12Vac 300mA



**K8099 Velleman kit £64.96**

**1.8W Mono Amplifier**  
 Compact mono 1.8W RMS 4Ω power stage, short circuit & reverse polarity protection. 30-18kHz. Power: 4-14Vdc 150mA



**E-1 Cebek Module £5.87**

**Proximity Card Reader Kit**  
 A simple security kit with many applications. RFID technology activates a relay, either on/off or timed. Supplied with 2 cards, can be used with up to 25 cards. Power: 9Vac or dc



**MK179 Velleman kit £14.25**

**Mini USB Interface Board**  
 New from Velleman this little interface module with 15 inputs/outputs inc digital & analogue in, PWM outputs. USB Powered 50mA, Software supplied



**VM167 Module £26.80**

**20W 2 Channel Amplifier**  
 Mono amplifier with 2 channels (Low & High frequency), 20W RMS 4Ω per channel, adjustable high level. 22-22kHz, short circuit & reverse polarity protection. Power: 8-18Vdc 2A



**E-14 Cebek Module £22.11**

**Running Microbug Kit**  
 Powered by two subminiature motors, this robot will run towards any light source. Novel shape PCB with LED eyes. Power: 2 x AAA Batteries



**MK127 Velleman kit £9.02**

**Thermostat Mini Kit**  
 General purpose low cost thermostat kit. +5 to +30°C Easily modified temperature range/min/max/hysteresis 3A Relay. Power: 12Vdc 100mA



**MK138 Velleman Kit £4.55**

**5W Stereo Amplifier**  
 Stereo power stage with 5W RMS 4Ω, 30-18kHz, short circuit & reverse polarity protection. Power: 6-15Vdc 500mA



**ES-2 Cebek Module £21.54**

**200W Power Amplifier**  
 A high quality audio power amp, 200W music power @ 4Ω 3-200kHz Available as a kit without heatsink or module including heatsink. **K8060 Velleman kit £12.85**  
**Heatsink for kit £9.95**  
**VM100 Module £38.54**



**Velleman Function Generator**  
 PC Based USB controlled function generator. 0.01Hz to 2Mhz Pre-defined & waveform editor. Software supplied. See web site for full feature list.



**PCGU1000 Velleman £118.38**

**12Vdc Power Supply**  
 Single rail regulated power supply complete with transformer. 130mA max, low ripple, 12Vdc with adjustment.



**FE-103 Cebek Module £13.16**

**MP3 Player Kit**  
 Plays MP3 files from an SD card, supports ID3 tag which can be displayed on optional LCD. Line & headphone output. Remote control add-on. Power: 12Vdc 100mA



**K8095 Velleman kit £39.99**

**Velleman PC Scope**  
 PC Based USB controlled 2 channel 60Mhz oscilloscope with spectrum analyser & Transient recorder. 2 Scope probes & software included. See web site for full feature list.



**PCSU1000 Velleman £249.00**

**1-180 Second Timer**  
 Universal timer with relay output. Time start upon power up or push button. LED indication. 5A Relay. Power: 12Vdc 60mA



**I-1 Cebek Module £12.92**

**DC to Pulse width Modulator**  
 A handy kit to accurately control DC motors etc. Overload & short circuit protection. Input voltage 2.5-35Vdc, Max output 6.5A. Power: 8-35Vdc



**K8004 Velleman kit £9.95**

**Velleman PC Scope/Generator**  
 PC Based USB controlled 2 channel oscilloscope AND Function generator. Software included. See web site for full feature list.



**PCSGU250 Velleman £113.67**

**Cyclic Timer**  
 Universal timer with relay output. Time start upon power up or push button. On & Off times 0.3-60 Seconds, LED indication. 5A Relay. Power: 12Vdc 80mA



**I-10 Cebek Module £14.12**

**Audio Analyser Kit**  
 A small spectrum analyser with LCD. Suitable for use on 2, 4 or 8Ω systems. 300mW to 1200W(2x) 20-20kHz Panel mounting, back-lit display. Power: 12Vdc 75mA

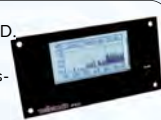

**K8098 Velleman kit £31.65**

**RF Remote Control Transmitter**  
 Single channel RF keyfob transmitter with over 13,122 combinations. Certified radio frequency 433.92MHz. Power: 12Vdc 2mA (inc) For use with TL-1,2,3,4 receivers.



**TL-5 Cebek Module £14.64**

**Light Detector**  
 Adjustable light sensor operating a relay. Remote sensor & terminals for remote adjustment pot. 5A Relay. Power: 12Vdc 60mA



**I-4 Cebek Module £13.98**

**USB DMX Interface**  
 512 DMX Channels controlled by PC via USB. Software & case included. Available as a kit or ready assembled module.



**K8062 Velleman kit £47.90**  
**VM116 Module £67.15**

**RF Remote Control Receiver**  
 Single channel RF receiver with relay output. Auto or manual code setup. Momentary output, 3A relay. Power: 12Vdc 60mA For use with TL-5 or TL-6 transmitters.



**TL-1 Cebek Module £28.25**

**Liquid Level Detector**  
 A liquid level operated relay. Remote sensor operates relay when in contact with a liquid. 5A Relay. Power: 12Vdc 60mA



**I-6 Cebek Module £13.08**

**USB Interface Board**  
 Featuring 5 in, 8 digital outputs, 2 in & 2 analogue outputs. Supplied with software. Available as a kit or ready assembled module.



**K8055 Velleman kit £24.80**  
**VM110 Module £34.90**

**Keypad Access Control**  
 An electronic lock with up to ten 4 digit codes. Momentary or timed (1-60sec/1-60min) output. Relay 5A. Power: 12Vdc 100mA Keypad included.



**DA-03 Cebek Module £54.26**

**Thermostat**  
 A temperature controlled relay. Adjustable between -10 to 60°C Sensor on remote PCB. Connector for external adjustment pot. 5A Relay. Power: 12Vdc 60mA



**I-8 Cebek Module £12.80**

**8 Channel USB Relay Board**  
 PC Controlled 16A relays with toggle, momentary or timed action. Test buttons included, available in a kit or assembled.



**K8090 Velleman kit £39.95**  
**VM8090 Module £58.40**

**AC Motor Controller**  
 A 230Vac 375W motor speed control unit giving 33 to 98% of full power. Power: 230Vac



**R-8 Cebek Module £12.14**

**Start / Stop Relay**  
 Simple push button control of a relay. Either 1 or 2 button operation. 5A Relay. Power: 12Vdc 60mA



**I-9 Cebek Module £12.83**

**Components Hardware Soldering Switches Test Equipment Transformers Motors**

**PCB Equipment Connectors Power Supplies Enclosures Relays**



**Editorial Offices:**

EVERYDAY PRACTICAL ELECTRONICS  
 EDITORIAL Wimborne Publishing Ltd., 113 Lynwood  
 Drive, Merley, Wimborne, Dorset, BH21 1UU  
**Phone:** (01202) 880299. **Fax:** (01202) 843233.  
**Email:** enquiries@wimborne.co.uk  
**Website:** www.epemag.com

See notes on **Readers' Technical Enquiries** below  
 – we regret technical enquiries cannot be answered  
 over the telephone.

**Advertisement Offices:**

Everyday Practical Electronics Advertisements  
 113 Lynwood Drive, Merley, Wimborne, Dorset,  
 BH21 1UU  
**Phone:** 01202 880299 **Fax:** 01202 843233  
**Email:** stewart.kearn@wimborne.co.uk

**Editor:**

MATT PULZER

**Consulting Editor:**

DAVID BARRINGTON

**Subscriptions:**

MARILYN GOLDBERG

**General Manager:**

FAY KEARN

**Graphic Design:**

RYAN HAWKINS

**Editorial/Admin:**

(01202) 880299

**Advertising and****Business Manager:**

STEWART KEARN

(01202) 880299

**On-line Editor:**

ALAN WINSTANLEY

**EPE Online****(Internet version) Editors:**

CLIVE (Max) MAXFIELD

and ALVIN BROWN

MIKE KENWARD

**Publisher:****READERS' TECHNICAL ENQUIRIES****Email:** techdept@wimborne.co.uk

We are unable to offer any advice on the use, purchase,  
 repair or modification of commercial equipment or the  
 incorporation or modification of designs published  
 in the magazine. We regret that we cannot provide  
 data or answer queries on articles or projects that are  
 more than five years' old. Letters requiring a personal  
 reply must be accompanied by a stamped self-  
 addressed envelope or a self-addressed envelope and  
 international reply coupons. We are not able to answer  
 technical queries on the phone.

**PROJECTS AND CIRCUITS**

All reasonable precautions are taken to ensure that  
 the advice and data given to readers is reliable. We  
 cannot, however, guarantee it and we cannot accept  
 legal responsibility for it.

A number of projects and circuits published in  
 EPE employ voltages that can be lethal. You should  
 not build, test, modify or renovate any item of mains-  
 powered equipment unless you fully understand the  
 safety aspects involved and you use an RCD adaptor.

**COMPONENT SUPPLIES**

We do not supply electronic components or kits for  
 building the projects featured, these can be supplied  
 by advertisers.

We advise readers to check that all parts are still  
 available before commencing any project in a back-  
 dated issue.

**ADVERTISEMENTS**

Although the proprietors and staff of EVERYDAY  
 PRACTICAL ELECTRONICS take reasonable  
 precautions to protect the interests of readers by  
 ensuring as far as practicable that advertisements are  
 bona fide, the magazine and its publishers cannot give  
 any undertakings in respect of statements or claims  
 made by advertisers, whether these advertisements  
 are printed as part of the magazine, or in inserts.

The Publishers regret that under no circumstances  
 will the magazine accept liability for non-receipt of  
 goods ordered, or for late delivery, or for faults in  
 manufacture.

**TRANSMITTERS/BUGS/TELEPHONE  
EQUIPMENT**

We advise readers that certain items of radio  
 transmitting and telephone equipment which may  
 be advertised in our pages cannot be legally used in  
 the UK. Readers should check the law before buying  
 any transmitting or telephone equipment, as a fine,  
 confiscation of equipment and/or imprisonment can  
 result from illegal use or ownership. The laws vary from  
 country to country; readers should check local laws.

# EPE EVERYDAY PRACTICAL ELECTRONICS

**Looking forward and looking back**

Another twelve issues of *EPE* have been and gone, and the New Year has an exciting batch of features and circuits lined up for you to enjoy. We have a great mix of analogue and digital projects, ranging from high-end hi-fi and precision instrumentation to semiconductor test equipment and a USB interface tester. There are projects large and small to suit all pockets and to match all levels of experience.

Some projects are modern twists on popular staples, such as this month's *Stereo Audio Compressor* and *3-Input Audio Switch* – very good projects by the way. Others, are genuine one-offs, and I've never seen anything like them before; for example, recycling CD-ROM motors to make tiny, high power brushless DC motors.

*Jump Start*, our series dedicated to newcomers, or those following courses taught in schools and colleges continues until the summer, and starting later in the year we have the next in our popular *Teach-In* series.

Whatever your interests in electronics, I'm certain there will be plenty to inspire and entertain you in the coming year's *EPE*.

**End of an era**

I don't wish to be over-dramatic, but with the recent closing down of the BBC's CEEFAX service I can't help feeling that something genuinely innovative has finally come to an end. CEEFAX was the world's very first teletext service; starting in 1974, it ran for 38 years. By modern standards, it was pretty basic. Originally, each screen had just 24 rows by 40 columns of characters, and the 'graphics' were basic to say the least. The user interface was equally barebones – just a user-entered numeric code for each page.

However, it did provide a regularly updated news, weather and rudimentary financial data service, which in many ways anticipated the same kind of on-demand information offering now provided by the BBC's website. While it may have been simple, it was also a good reminder that information can be transmitted and received using limited technology. Not everything needs to have a slick, super-high-resolution, high bandwidth specification to work. Sometimes, simpler is better.

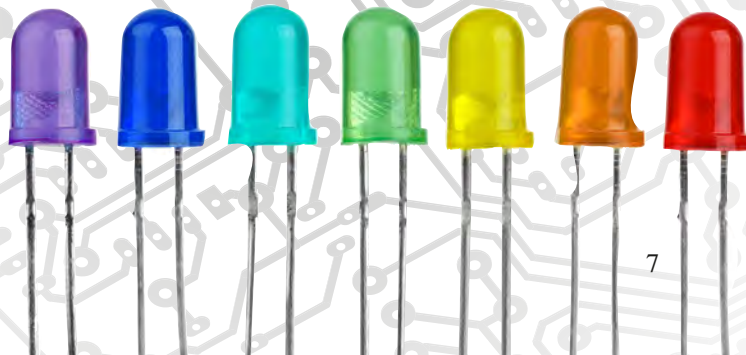

# NEWS

A roundup of the latest Everyday News from the world of electronics



## Lighting gets a colourful makeover – report by Barry Fox

Philips of the Netherlands started out making light bulbs in 1891 and diversified into radio, TV, audio and video, with varying degrees of success and failure subsidised by steady profits from lighting. Now

from across the room or across the world. One bridge can control up to 50 lamps (which cost £47 each if bought separately). Because ZigBee is a mesh wireless system, each lamp acts a repeater to extend control

range by another 20m or so. It may all sound rather fanciful, and an expensively over-engineered way to switch home lights from Timbuktu, but some of the app tricks already available look useful and/or fun. For instance, graphics software lets the bridge grab a colour from a displayed photo and set the lighting to match; so a picture of a sunset can be used to set the room lighting to sunset hue. Some or all of the room lighting can be varied, to suit individual taste or time of day, between ‘cold’ with heavy blue content to ‘warm’ candlelight with more red.



Control via a dedicated smartphone or tablet app for Apple or Android

Each lamp contains 11 LED light emitter chips, some white and some coloured, with a total power consumption of 8.5W, equivalent in light output to a 50W incandescent lamp (600 lumens). The app can dim the lamps together,

or separately, change their colour or white colour temperature, and switch on an off at predetermined times.

‘Hue is a game changer in lighting’, said Jeroen de Waal, head of marketing and strategy at Philips Lighting. ‘It’s a completely new way to experience and interact with light. What you do with it is up to you. It’s a personal wireless light system.’

### More features to follow

Future development will include synchronising room light changes with computer gameplay, movie action, or music – much as the Ambilight system in some Philips TVs varies room lighting from lamps in the back of the TV screen. Also ‘on the road map’ is a plan to let motion sensors switch lights dependent on where people are in a room.

Philips claims that Hue can be ‘set-up in minutes’ because the system is ‘intuitive and seamless’. However, anyone who has set up any system that depends on a network will know that practice does not always follow theory, and although Hue has been rolling out worldwide since 30 October 2012, Philips has so far been unable to provide any Hues for hands-on independent testing. So this report is not a review recommendation.

Since the ZigBee Light-Link is built as an open standard, Hue can be integrated with other ZigBee equipment, such as ZigBee Home Automation, ZigBee Input Device, ZigBee Remote Control and ZigBee Health Care.

Developers can learn more at [www.meethue.com](http://www.meethue.com)

### Networked lighting

The owner uses an Apple or Android smartphone or tablet, with app installed, to send lighting control signals to the cloud site. The cloud then sends the control signals to the bridge, which radiates them as ZigBee Light-Link standard wireless signals to the lamps, which have built-in ZigBee transceivers powered from the mains.

This tortuous path lets the tablet or smartphone control the lamps

from across the room or across the world. One bridge can control up to 50 lamps (which cost £47 each if bought separately). Because ZigBee is a mesh wireless system, each lamp acts a repeater to extend control range by another 20m or so.

Each lamp contains 11 LED light emitter chips, some white and some coloured, with a total power consumption of 8.5W, equivalent in light output to a 50W incandescent lamp (600 lumens). The app can dim the lamps together,

### Software control

The basic Philips app comes with a library of four light recipes, pre-programmed lighting settings based on research Philips did in 100 homes in New York, Berlin and Shanghai on the biological effects of lighting on the body. The aim is to use light and colour balance to help users relax, read, concentrate or energise. Hue uses an open source platform, so developers can explore ways for light to ‘enhance consumers’ lives’.

# Nanotube breakthrough

IBM scientists have demonstrated a new approach to carbon nanotechnology that opens up the path for commercial fabrication of dramatically smaller, faster and more powerful computer chips. For the first time, more than ten thousand working transistors made of nano-sized tubes of carbon have been precisely placed and tested in a chip using standard semiconductor processes.

Aided by rapid innovation over four decades, silicon technology has continually shrunk in size and improved in performance, thereby driving the information technology revolution. Silicon transistors have been made smaller year after year, but they are approaching a point of fundamental physical limitation.

Their increasingly small dimensions, now reaching the nanoscale, will prohibit any gains in performance due to the nature of silicon and the laws of physics. Within a few more generations, classical scaling and shrinkage will no longer yield the sizable benefits of lower power, lower cost and higher speed processors that users have become accustomed to.

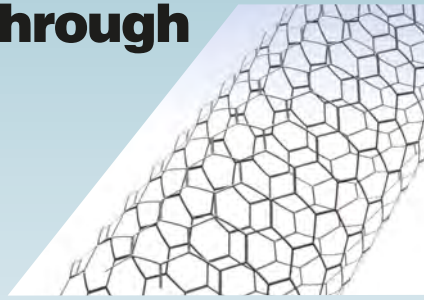

Single-atom sheets of carbon roll up to form carbon nanotubes – 10,000 times smaller than a single strand of hair – that can be used as transistors on a chip

Carbon nanotubes represent a new class of semiconductor materials whose electrical properties are more attractive than silicon, particularly for building nanoscale transistor devices that are a few tens of atoms across. Electrons in carbon transistors can move easier than in silicon-based devices, allowing for quicker transport of data. The nanotubes are also ideally shaped for transistors at the atomic scale, an advantage over silicon. These qualities are among the reasons to replace traditional silicon transistor with carbon – and coupled with new chip design architectures – will allow computing innovation on a miniature scale for the future.

## It's a hard drive

The capacity of hard drives could increase by a factor of five thanks to processes developed by chemists and engineers at The University of Texas in Austin, US. By simply ensuring there is no magnetic material between 'bits' of data, researchers hope to overcome approaching physical limits and quintuple the current data density of 1TB per square inch.

## PiFace



Farnell is now distributing 'PiFace Digital', a new easy-to-use board that allows the Raspberry Pi to control and sense physical devices such as lights, motors and sensors. The new board is targeted at beginners of all ages. It is hoped to appeal to schoolchildren, and includes a range of learning materials designed by the University of Manchester aimed at making the device easy for teachers to use in the classroom.

## Mobile broadband – a mixed start

Testing mobile broadband is vastly more complicated than fixed line broadband, as there are many more variables involved, from whether it is raining to being a few feet either direction can mean you get a much better signal, plus you have no way of knowing how many others are connected to the same cell tower.

This is no surprise to anyone used to 3G services. The new 4G service from EE (Everything Everywhere Limited: Orange plus T-Mobile) at 1800MHz is not immune to these problems either, including signal shadow in cities – EE has said that while it has launched services in 11 UK cities, some areas inside the footprint will still need 'infill' to get the best service.

Some 3G users on EE contracts have also been complaining that their service has been slower than usual in order to make the new 4G service seem ultra quick. However, the last two months have also seen a lot of new mobile phones and tablets launched, which may be leading to even greater congestion on existing 3G networks.

For example, with Apple's latest mobile operating system, iOS 6, offering built-in navigation that relies on a data connection rather than a

large set of maps held in the phone's storage, the number of phones with links to cell towers has increased. 4G should support more simultaneous connections, in addition to offering a better link back from the base station to the Internet at large.

When suggesting typical speeds of 8Mbps to 12Mbps, EE is actually understating what 4G is capable of in ideal conditions. As such, it is attempting to abide by new advertising rules that have come into effect for mobile broadband services, and will require all mobile operators to advertise a speed that people can actually get, rather than the theoretical speed of a device.

As has happened with fixed broadband advertising, this has led to people thinking that providers are slowing down their services, when all they are doing is basing their advertising on measured real-world speeds, rather than laboratory tests.

### Further information

Thinkbroadband has an app for Android devices ([www.thinkbroadband.com/speedtest/android.html](http://www.thinkbroadband.com/speedtest/android.html)). It will test your speed when out and about, and if GPS data is available will plot your speeds on a map.

## TITANIC SPEED



November 2012, Cray's latest supercomputer claimed the title for the world's fastest. The supercomputer (named 'Titan') resides at the US Department of Energy's Oak Ridge National Laboratory, and is powered by a combination of CPUs and GPUs, which feature 18,688 nodes, each of which contains an AMD 16-core Opteron and a NVIDIA Tesla K20X GPU accelerator, equating to a massive 560,640 processors in total. Titan has 710 terabytes of memory.

The 560,640 processors are capable of generating 17.59 petaflops (quadrillion floating-point operations per second), but are capable of a theoretical peak speed of 27 quadrillion calculations per second – 27 petaflops – while using approximately 9MW of electricity, roughly the amount required for 9,000 homes.

By JOHN CLARKE and GREG SWAIN

# 3-Input Stereo Audio Switcher

Need more analogue audio inputs for your stereo amplifier or home-theatre set-up? This 3-Input Stereo Audio Switcher will do the job. It works with an infrared remote control or you can just press one of the front-panel buttons to select a program source.

**T**HIS handy *3-Input Stereo Audio Switcher* has a pleasingly minimalist appearance. It is housed in a metal diecast case, which we spray-painted black. The switch board mounts on the front panel, while four pairs of stereo RCA phono sockets on the main PCB (three for the inputs and one for the outputs) protrude through holes in the rear panel. Power comes from a 9V to 12V plugpack, and the *Switcher* typically draws less than 600mW.

Virtually any universal remote control can be used with our switcher, and there are three different 'modes' (or devices) to choose from – TV, SAT1 and SAT2. The default mode is TV,

but SAT1 can be selected by pressing (and holding) switch button S1 during power-up. Similarly, SAT2 is selected by pressing button S2 at power-up, while pressing S3 at power up reverts to TV mode.

Of course, having selected a mode, you must also program the remote with the correct code. We'll have more to say about that later.

In operation, the unit lets you select between any one of three stereo analogue inputs by pressing the '1', '2' or '3' button on the remote. Alternatively, you can press the buttons on the front-panel switchboard.

An integral blue LED in each switch button lights to indicate the

selected input. This occurs both when a button is pressed and when the remote control is used. The blue switch LEDs also serve as power indicators, while the orange acknowledge (ACK) LED on the front panel flashes whenever a valid remote control signal is received.

By changing a couple of linking options, you can also build the unit so that it responds to buttons 4, 5 and 6 on the remote, or to buttons 7, 8 and 9 (ie, instead of 1, 2 and 3). You might want to do this if buttons 1, 2 and 3 have been allocated to another piece of equipment, or if you want to build two such units and control them using the same remote.

## Parts List – 3-Input Stereo Audio Switcher

2 PCBs, codes 881 (Main) and 882 (Switch), both available from the *EPE PCB Service*  
 1 9V to 12V 300mA plugpack  
 1 diecast aluminium box, 119mm × 94mm × 57mm  
 3 DPDT 5V relays, PCB-mount  
 1 4MHz crystal (X1)  
 1 18-pin machined DIL socket  
 4 PCB-mount gold-plated dual RCA phono sockets  
 3 PCB-mount pushbutton switches, with blue LEDs (S1 to S3) (Jaycar SP0614)  
 8 M3 × 10mm tapped spacers  
 1 2.5mm PCB-mount DC socket  
 2 ferrite beads (L1, L2)  
 1 10-pin PCB-mount IDC header socket  
 1 10-pin 90° PCB-mount IDC header socket  
 2 10-pin IDC line sockets  
 1 100mm length 10-way IDC cable  
 9 M3 × 6mm pan-head machine screws  
 4 M3 × 6mm pan-head machine screws (black)  
 4 M3 × 10mm pan-head machine screws  
 4 No.3 × 10mm screws (black)  
 5 M3 nuts  
 9 M3 washers

### Semiconductors

1 PIC16F88-I/P programmed microcontroller (IC1)  
 1 38kHz 5V infrared receiver module (IRD1)  
 3 BC337 NPN transistors (Q1 to Q3)  
 1 7805 5V regulator (REG1)  
 4 1N4004 diodes (D1 to D4)  
 1 3mm orange LED (LED4)

### Capacitors

2 100µF 16V radial electrolytic  
 1 10µF 16V radial electrolytic  
 1 100nF MKT polyester  
 2 470pF MKT polyester or MKP polypropylene (NOT ceramic)  
 2 22pF ceramic

### Resistors

6 4.7kΩ	1 1kΩ	7 100Ω
3 1.8kΩ	1 330Ω	

### Software

All software program files will be available from the *EPE* website at [www.epemag.com](http://www.epemag.com).

Although we do not supply pre-programmed microcontrollers, you can purchase the programmed micro featured in this project from: [parts@siliconchip.com.au](mailto:parts@siliconchip.com.au)

(IC1) switches its RA2 port (pin 1) high. This pulls the base of transistor Q1 high via a 4.7kΩ resistor, and so Q1 turns on and switches on RLY1 to select Input 1 (CON1). Similarly, RLY2 and RLY3 are switched on via Q2 and Q3 respectively when buttons 2 and 3 are pressed.

The firmware in the micro ensures that only one relay can be on at any time. Pressing a button (either on the remote or the switch board) turns the currently-activated relay off before the newly-selected relay turns on. If the input button corresponds to the currently-selected input, then no change takes place. The last input selected is restored at power up.

Diodes D1 to D3 protect transistors Q1 to Q3 by quenching the back-EMF when the relays switch off.

Pin 15 and pin 16 of IC1 are the oscillator pins for 4MHz crystal X1, which is used to provide the clock signal. This oscillator runs when the circuit is first powered up for about 1.5s. It also runs whenever a signal from the infrared receiver (IRD1) is received at its RB0 input (pin 6) or when a button on the switchboard is pressed, and then for a further 1.5s after the signal ceases.

The oscillator then shuts down and the processor goes into sleep mode. This ensures that no noise is radiated into the audio signal paths during normal operation.

### Performance

By using relay switching and carefully designing the PCB (especially in regards to earthing), we've been able to achieve an excellent specification. The signal-to-noise ratio is >116dB unweighted relative to 1V RMS (20-22kHz bandwidth), while channel separation is 109dB @ 1kHz and 90dB @ 10kHz. The THD+N (total harmonic distortion plus noise) is <0.0004% @ 1kHz (20Hz-22kHz), a figure that's basically below the measurement capabilities of our test equipment.

The interchannel crosstalk is -116dB @ 1kHz and -101dB at 10kHz (unused input terminated with 100Ω).

Suffice to say, this unit will have negligible impact on the audio signal being switched. It would be ideal for use with our recent amplifier projects, or it could be used in any other audio or home-theatre set-up where you need extra analogue inputs.

### Circuit details

Refer now to Fig.1 for the full circuit details. It uses 5V DPDT relays (RLY1 to RLY3) to switch the three stereo inputs: Input 1, Input 2 and Input 3 (CON1 to CON3). These relays are in turn controlled by NPN transistors Q1 to Q3, depending on the signals from microcontroller IC1 (PIC16F88-I/P).

The incoming stereo line-level inputs are connected to the NO (normally open) contacts of each relay. When a relay turns on, its common (C) contacts connect to its NO contacts, and the stereo signals are fed through to the left and right outputs via 100Ω resistors and ferrite beads. The resistors isolate the outputs from the audio cable capacitance, while the beads and their associated 470pF capacitors filter any RF signals that may be present.

When button 1 on the remote (or on the switch board) is pressed, the micro

### Power supply

Power for the circuit is derived from a 9V to 12V plugpack. This is fed in via reverse-polarity protection diode D4 to regulator REG1, which provides a +5V output. A 100µF capacitor filters the supply to REG1, while 10µF and 100nF capacitors decouple the output.

The +5V rail powers the microcontroller and the relays. In addition, this rail is also fed to pin 3 of CON5, while pin 5 of CON5 is connected to ground (0V). This provides power to the switchboard via the IDC cable and CON6.

### Switchboard circuit

Fig.1 also shows the circuitry for the switchboard. This includes the infrared receiver (IRD1), the three momentary contact pushbutton switches with integral blue LEDs (LED1 to LED3), the ACK (acknowledge) LED and the 10-way header socket (CON6).

## Constructional Project



The rear panel carries the four RCA socket pairs, with the output pair at left.

The 38kHz infrared signals from the remote are picked up by IRD1 and demodulated to produce a serial data pulse train at its pin 1 output. This signal is then fed to the RB0 (pin 6) input of the PIC16F88-I/P (IC1) via pin 8 of headers CON6 and CON5. IC1 decodes the signal to determine the RC5 code sent by the remote, and then switches its RA2 to RA4 outputs accordingly to select the corresponding input.

LED4 (ACK) flashes each time a valid code is received from the remote. It's driven by the RB4 output of IC1 via a 330Ω current-limiting resistor.

Power for IRD1 comes in via pin 3 of CON6 and is decoupled using a 100Ω resistor and a 100μF capacitor. This filtered +5V rail is applied to pin 3 of IRD1, while pin 2 connects to ground.

### Pushbutton switches

Switches S1 to S3 allow manual selection of the input. One side of each switch is connected to ground, while the tops of S1 to S3 are pulled high (ie, to +5V) via 4.7kΩ resistors, and are respectively connected to the RB7, RB6 and RB5 ports of IC1.

Similarly, the cathodes (K) of the internal blue LEDs (LEDs1-3) are connected to ground (0V), while their anodes (A) are driven by ports RB1 to RB3 respectively via 1.8kΩ current-limiting resistors.

When a switch is pressed, it pulls the corresponding port on IC1 low and

this wakes the microcontroller, which then processes the data and turns on the corresponding relay. At the same time, either RB1, RB2 or RB3 switches high to light the appropriate switch LED. IC1 then promptly goes back to sleep again.

### Construction

Fig.2 shows the assembly details for the main PCB, while Fig.3 shows the switchboard assembly. Both boards are available from the *EPE PCB Service*, codes 881 (Main) and 882 (Switch).

Install the resistors and diodes D1 to D4 on the main PCB first, then install the ferrite beads, an 18-pin IC socket for IC1 and the two 470pF MKT capaci-

tors near CON4 (do **NOT** substitute ceramic capacitors). The two 22pF capacitors below crystal X1 can then go in, along with the 100nF capacitor and the two electrolytics (make sure that the latter are correctly oriented).

That done, install transistors Q1 to Q3, crystal X1 and the 10-way header socket CON5. The latter must go in with its slotted key-way towards IC1 (see photo). Regulator REG1 can now be installed, and that's done by first bending its leads down through 90° to match the holes in the PCB. Its metal tab is then fastened to the PCB using an M3 × 6mm machine screw and nut, *after* which the leads can be soldered.

Don't solder the regulator's leads *before* it's fastened into place. If you do, you could crack the PCB tracks as the mounting screw is tightened.

The main board assembly can now be completed by installing the DC socket, the relays and the four stereo RCA phono input socket pairs. Don't install the microcontroller (IC1) yet – that step comes later, after the power supply has been checked.

Once the board has been finished, fit a 10mm spacer to each corner, as shown in Fig.6.

### Switchboard assembly

Start the assembly of the switchboard PCB (Fig.3) by installing the resistors, the 90° 10-way header (key-way up) and the 100μF capacitor. **The latter should be installed with its body leaning by about 60°, as shown in one of the photos, so that it won't later foul the front panel of the case.**

## Changing the remote control buttons

By changing the linking options on the PIC microcontroller, you can make the unit respond to buttons 4, 5 and 6 on the remote, or to buttons 7, 8 and 9 (ie, instead of buttons 1, 2 and 3).

By default, pin 18 and pin 17 (RA1 and RA0) of the micro are tied to ground by two thin tracks on the PCB (the ground tracks run down the centre of the IC, immediately to the left of these pins). As a result, both pins are at logic 0 (ie, they are both low) and the unit responds to buttons 1, 2 and 3 on the remote.

If you want the unit to respond to buttons 4, 5 and 6, cut the track between pin 17 and ground and connect this pin to the adjacent +5V pad (immediately to the right) instead. You can do this using a solder bridge or a short length of tinned copper wire.

Alternatively, to make the unit respond to buttons 7, 8 and 9, cut the link between pin 18 and ground and connect this pin to the +5V pad. Tying both pin 17 and pin 18 high (ie, at logic 1) restores button 1, 2 and 3 operation (ie, it responds to the 1, 2 and 3 buttons when both inputs are tied high or both tied low).

The truth table on the circuit diagram shows the various options. Just remember that a logic 1 represents a high (ie, +5V), while logic 0 represents a low (ie, ground).

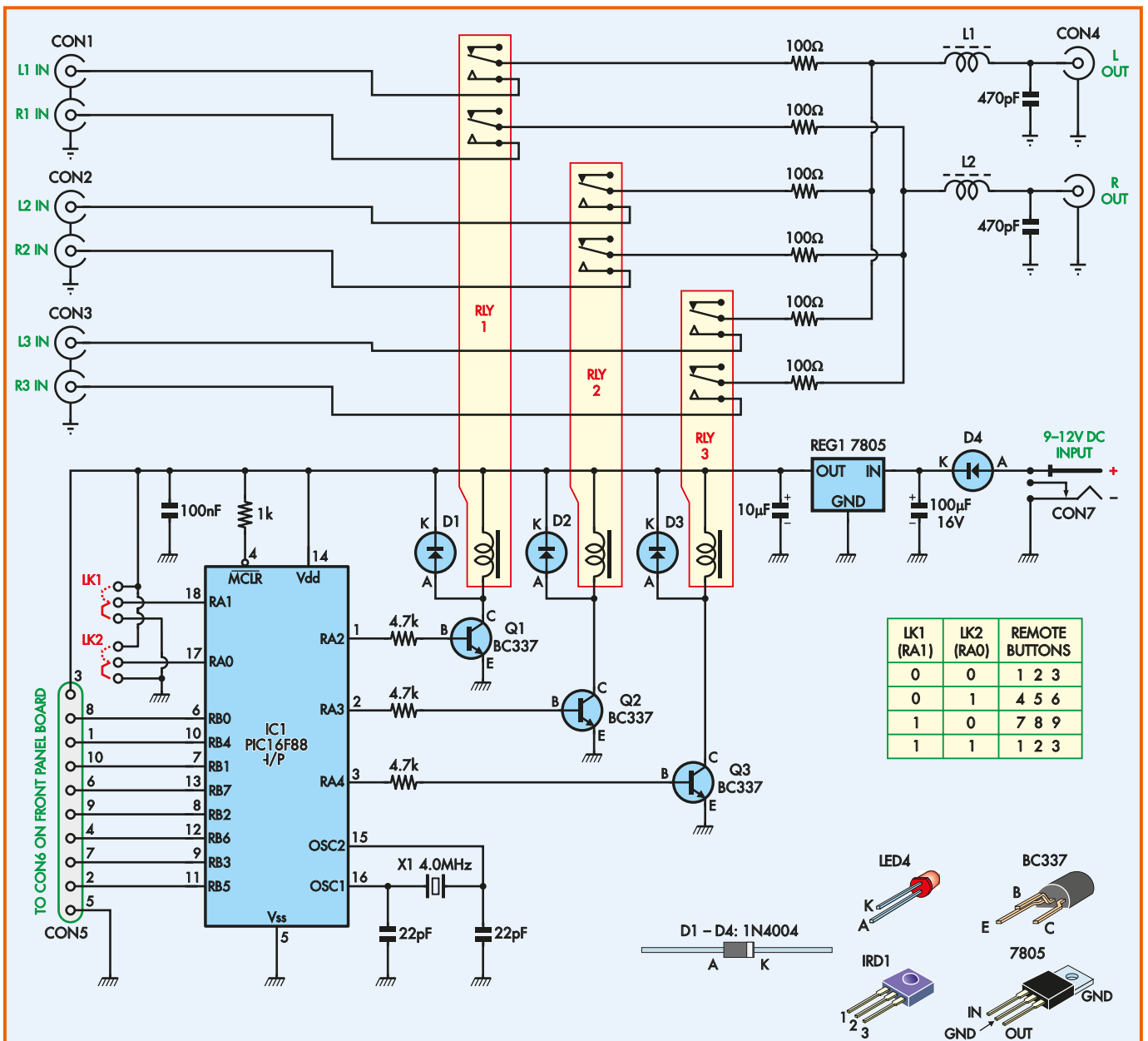

## 3-INPUT STEREO AUDIO SWITCHER

Fig.1: the circuit uses a PIC16F88-I/P microcontroller (IC1) to decode signals from an infrared receiver (IRD1) and pushbutton switches S1 to S3. The micro then drives relays RLY1 to RLY3 via transistors Q1 to Q3 to switch the selected input through to the stereo outputs at CON4. Diode D4 provides reverse polarity protection, while REG1 provides a regulated +5V supply.

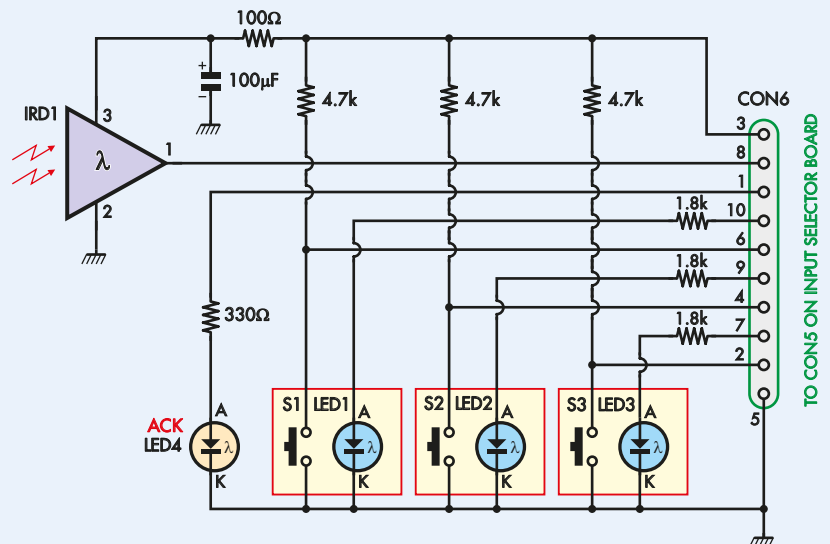

# Constructional Project

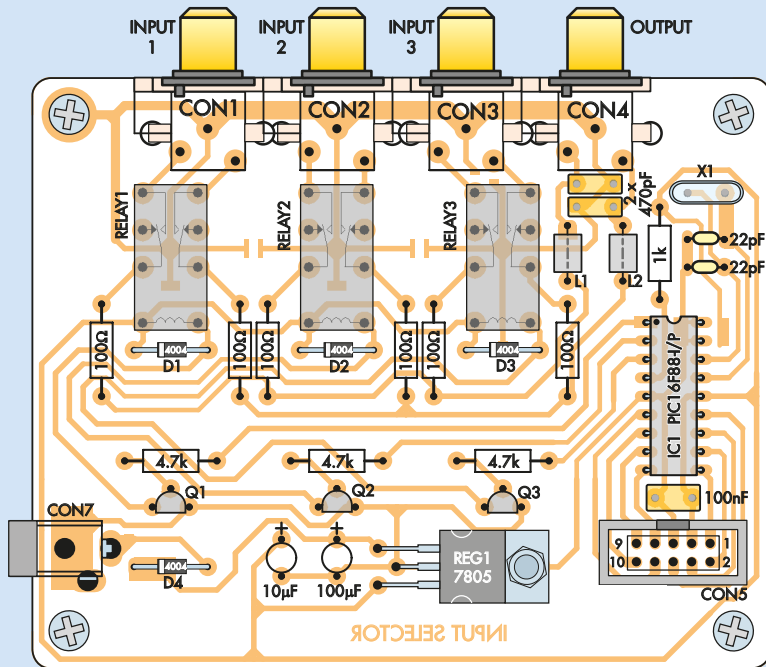
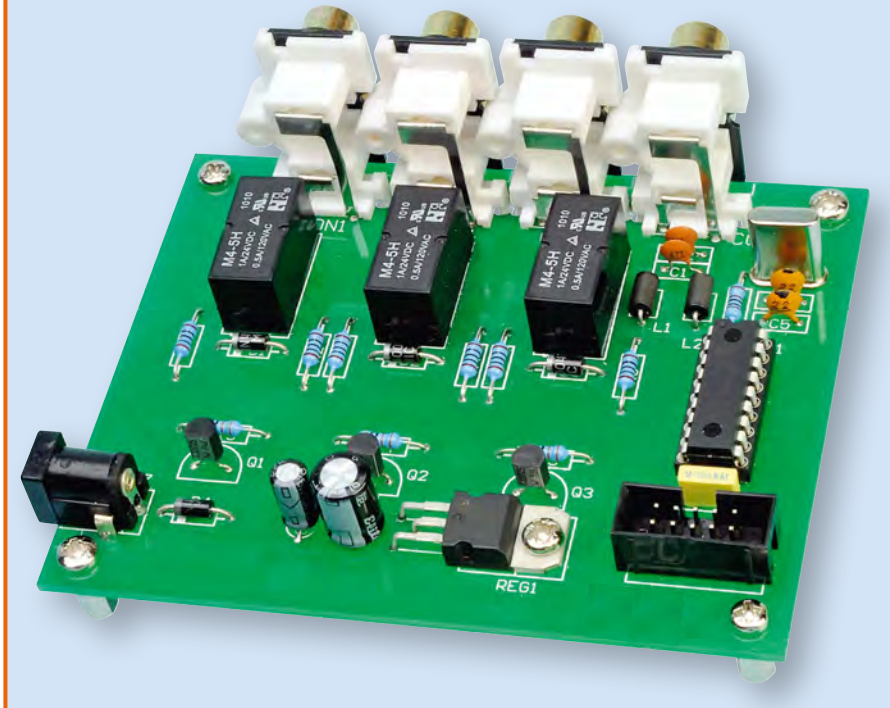

Fig.2: follow this diagram and the photo below to build the main PCB. Note that we initially used 470pF ceramic capacitors across the outputs, but these were later changed to MKT types for lower distortion.



The three pushbutton switches can now go in, but note that they must be installed the right way around. These have kinked pins at each corner, plus two straight pins for the integral blue LED. The anode pin is the longer of the two, and this must go in the hole marked 'A' on the layout diagram.

Once the pins are in, push the buttons all the way down so that they sit

flush against the PCB before soldering their leads.

Next on the list is LED4. It must be installed with its body exactly 10mm above the PCB. This can be done by pushing it down on to a 10mm-high cardboard spacer. Check that it's oriented correctly before soldering its leads – its anode lead is the longer of the two.

## Infrared receiver

The infrared receiver (IRD1) must be installed so that its domed lens is aligned with LED1 and the switches. The first step is to bend its leads down by 90° exactly 5mm from its body. The device should then be installed with its body exactly 9mm above the PCB (use a 9mm spacer to set the height).

This will ensure that the surface around its domed lens rests against the inside of the case wall when the switch-board is later mounted in position.

Alternatively, you can leave IRD1 out for the time being and mount it after the case has been drilled. If you elect to do that, it's just a matter of first pushing its leads through the PCB, then mounting the switch board in the case. The switch side of the case is then positioned face down, after which IRD1 is slid into position and its leads soldered.

The switch board assembly can now be completed by securing M3 x 10mm spacers plus M3 nuts (which act as additional spacers) to each corner – see Fig.6 and photo.

## Drilling the case

The next step is to drill the case. Photocopy and use the four drilling templates shown Fig.4. In each case, it's just a matter of aligning the blue lines with horizontal and vertical pencil lines marked on the case itself. The templates are then secured in place with sticky tape, after which you can drill the holes.

It's important to be accurate with the hole locations, so be sure to position each template carefully and to start each hole with a very small pilot drill (eg, 1mm). The holes can then be carefully enlarged to size.

You can use drills up to about 4mm, but after that it's best to enlarge the holes using a tapered reamer. This will have to be done for the switch holes, the RCA phono socket holes and the access hole for the DC socket.

It's fairly easy to get the switch holes all the same size – just ream one out to the correct size, then push the reamer into the hole as far as it will go and wind some sticky tape around the outside where it meets the case. The other two holes are then reamed up to the sticky tape.

The RCA phono socket holes are done in exactly the same way.

**Note that the main PCB is not mounted centrally on the base (lid) of**



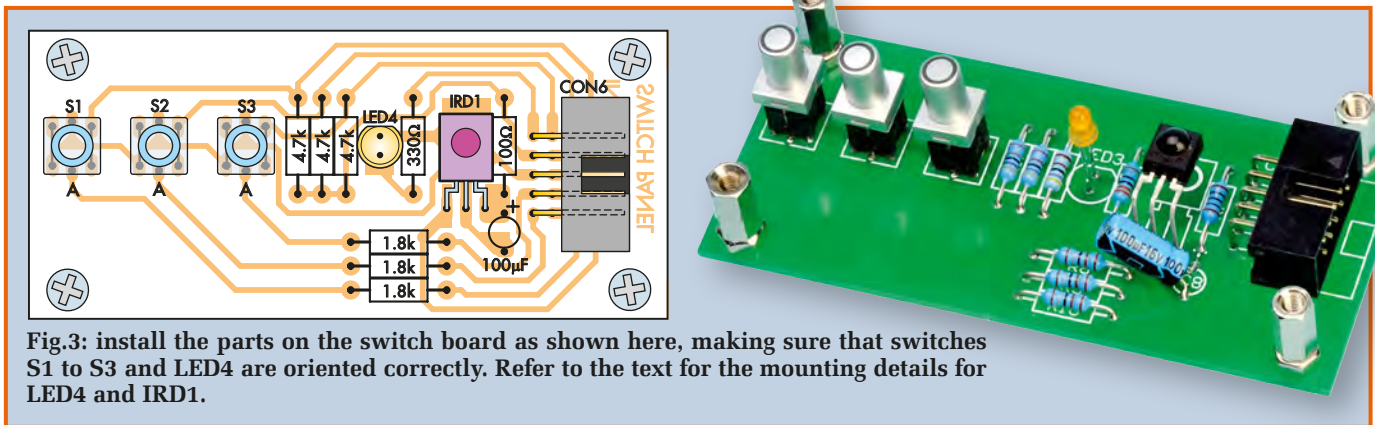

Fig.3: install the parts on the switch board as shown here, making sure that switches S1 to S3 and LED4 are oriented correctly. Refer to the text for the mounting details for LED4 and IRD1.

the case, but is offset by 3mm towards the rear. It's just a matter of drawing horizontal and vertical centre lines on the base and lining up the blue lines on the template with these before taping it into position.

Once the drilling is complete, deburr all holes using an oversize drill or a small rat-tail file. The case can then be spray-painted matte black (three or four thin coats are much better than one thick coat).

### Making the IDC cable

Fig.5 shows how to make the IDC cable that links the two PCBs together. Note that pin 1 on the header sockets is indicated by a small triangle in the plastic moulding, and the red stripe of the cable must go to these pins.

You can either crimp the IDC headers to the cable in a vice or use an IDC crimping tool. Don't forget to fit the locking bars to the headers after crimping, to secure the cable in place.

Having completed the cable, check that the headers have been correctly terminated. This can be done by plugging them into the matching sockets on the PCBs and then checking for continuity between the corresponding pins at either end using a multimeter.

### Initial tests

Before installing the PIC microcontroller, it's a good idea to check that the power supply is correct. To do this, connect a 9V to 12V DC plugpack, apply power and check the voltage between pin 14 and pin 5 of the IC socket. Pin 14 should be at +5V with respect to pin 5 (GND).

If you don't get any output from REG1, check the supply polarity and the orientation of diode D4.

Assuming the supply is correct, switch off, install the microcontroller

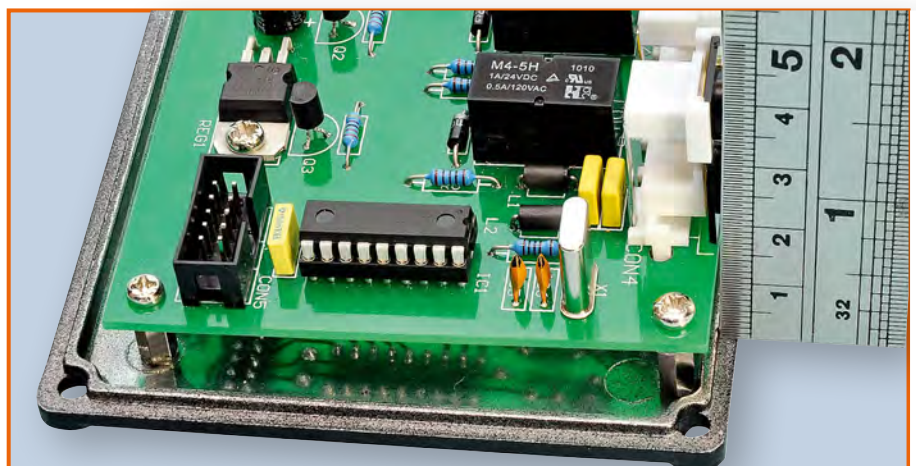

The main board is mounted so that its rear edge lines up with the outside of the lip that runs around the inside edge of the base (lid).



This view shows the switch board mounted inside the case, prior to the installation of the main board and base assembly.

# Constructional Project

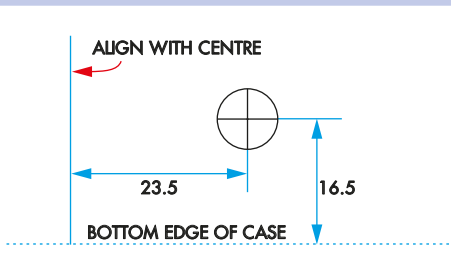
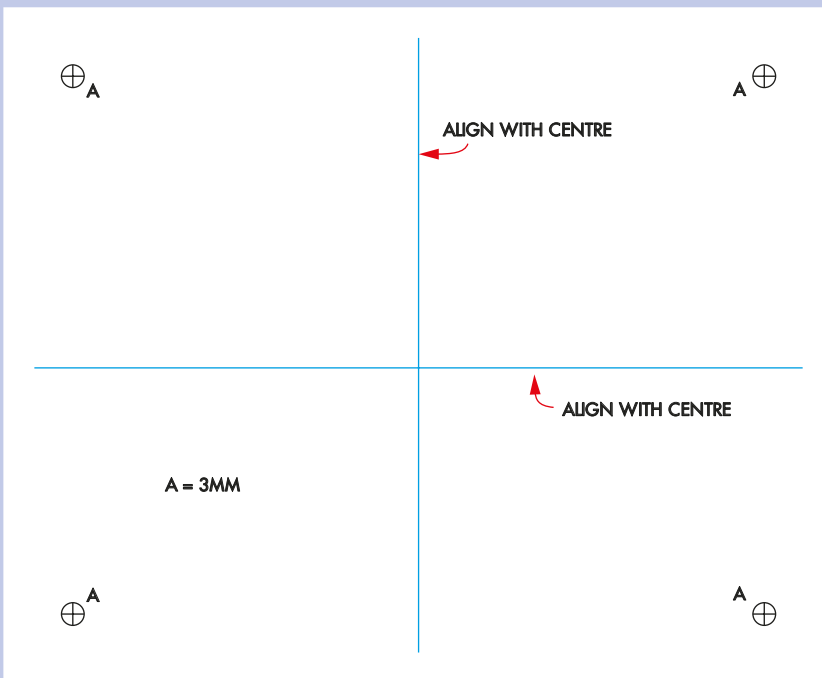
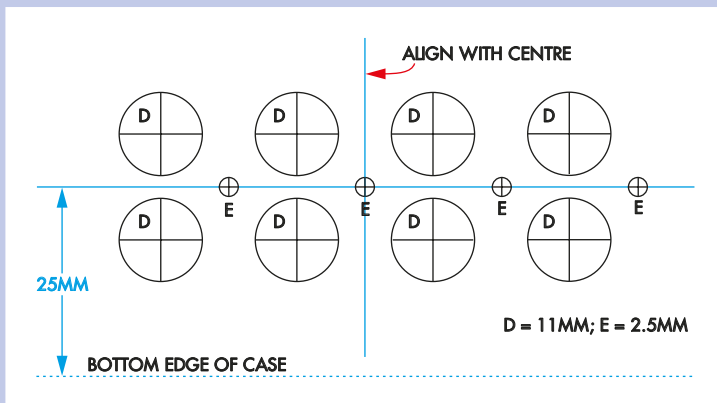
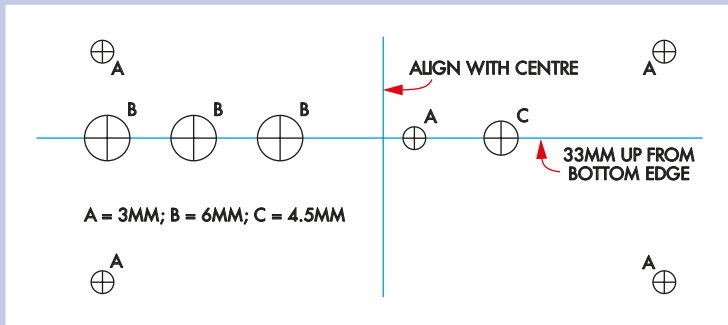

**Fig.4: Photocopy these drilling templates to use as guides for your unit**

and make sure the two boards are connected together via the IDC cable. That done, reapply power and check that one of the blue switch LEDs lights. You should also hear a faint click from the corresponding relay as it turns on.

Now try changing the input selection using the switches. Each time you press a button, its LED should light and you should hear the relays switch over. If there's no action, check that power is being applied to the switchboard PCB (the junction of the 4.7kΩ resistors should be at +5V with respect to ground).

## Remote control

The remote control function can now be tested using a suitable remote – eg, the Jaycar AR1726. As stated earlier, the default device mode programmed into the micro is TV, but if this conflicts with other equipment you can use SAT1 or SAT2 instead. Just press (and hold) switch button S1 at power-up for SAT1, button S2 for SAT2 or button S3 to revert to TV mode.

**Once you've chosen the 'device' mode, you also have to program the correct code into the remote. For the Jaycar AR1726, use 103 for TV, 1317 for SAT1 or 1316 for SAT2.**

If you have some other universal remote, it's just a matter of testing the various codes for a Philips device until you find one that works (most Philips devices rely on the RC5 code standard).

Having programmed the remote, check that the inputs can be selected using the 1, 2 and 3 buttons. Each time a button is pressed, the orange ACK LED should flash and you should hear a 'click' as the corresponding relay switches on. The blue LED in the corresponding switch button should also light.

If the ACK LED doesn't flash and there's no response from the relays, make sure that the remote is programmed correctly. Check also that the correct device has been selected (ie, TV, SAT1 or SAT2). The ACK LED won't flash at all unless everything is correct.

## Final assembly

Once everything is working correctly, the unit can be installed into the case. Fig.6 shows the details.

The switchboard is secured inside the case using four M3 × 6mm black

pan-head screws from the outside. Plug the IDC cable into its header before fitting this board, then check that the switches operate freely, without fouling the edges of their holes. The ACK LED should just protrude through the case, while the infrared receiver lens should be against the case wall and the lens centred in its hole.

The main board sits on the base (lid) of the case and is secured to it using four M3 × 10mm machine screws, which also hold the rubber feet in place. **Note that the four M3 washers are also fitted under the spacers at the rear.** This tilts the board back slightly so that the phono sockets mate with the sloping wall of the case. Don't forget to connect the IDC cable before fitting the assembly together and installing the case screws.

Finally, install the four No.3 × 10mm screws at the rear. These go into the plastic bodies of the RCA phono socket assemblies and secure them against the inside of the case, so that they are held fast when the cables are plugged into their sockets.

*EPE*

Reproduced by arrangement  
with SILICON CHIP  
magazine 2012.  
[www.siliconchip.com.au](http://www.siliconchip.com.au)

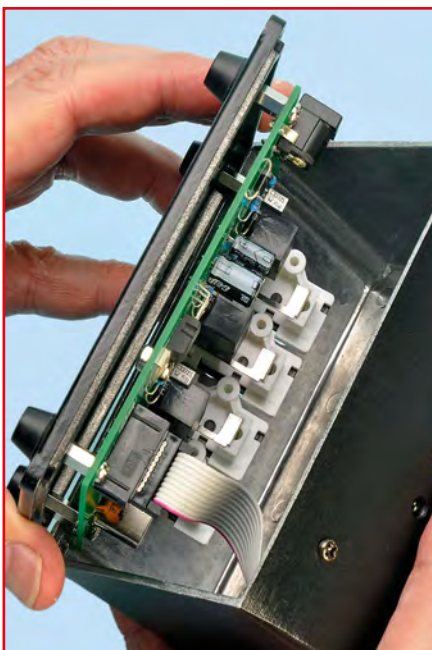

Be sure to attach the IDC cable before fitting the main board/base assembly to the case and installing the case screws.

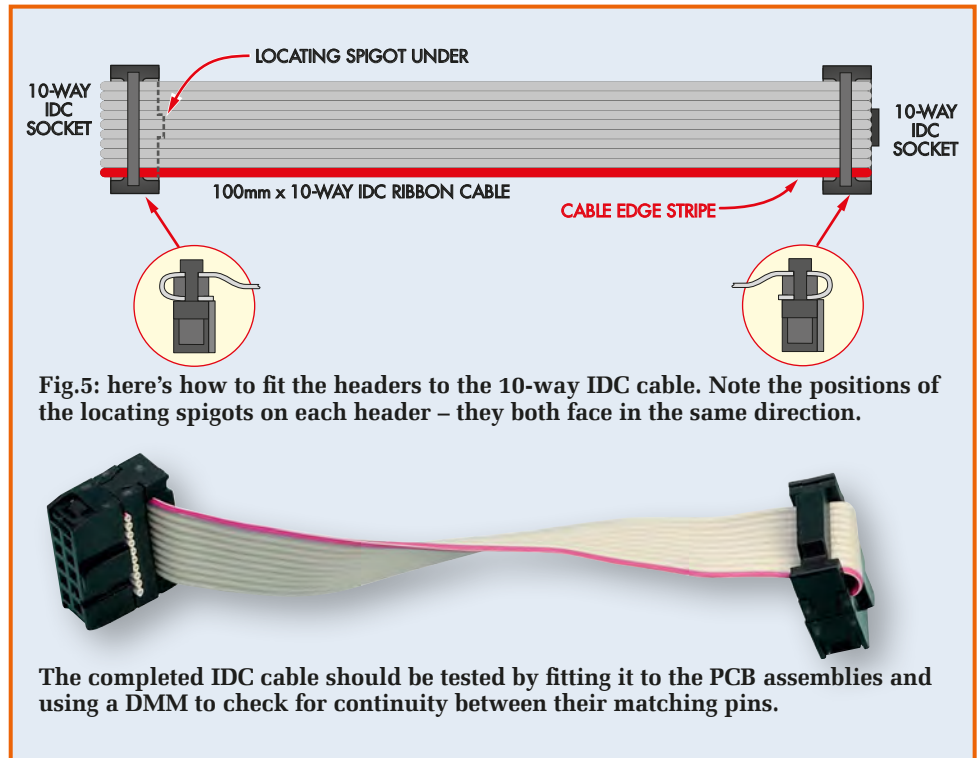

Fig.5: here's how to fit the headers to the 10-way IDC cable. Note the positions of the locating spigots on each header – they both face in the same direction.

The completed IDC cable should be tested by fitting it to the PCB assemblies and using a DMM to check for continuity between their matching pins.

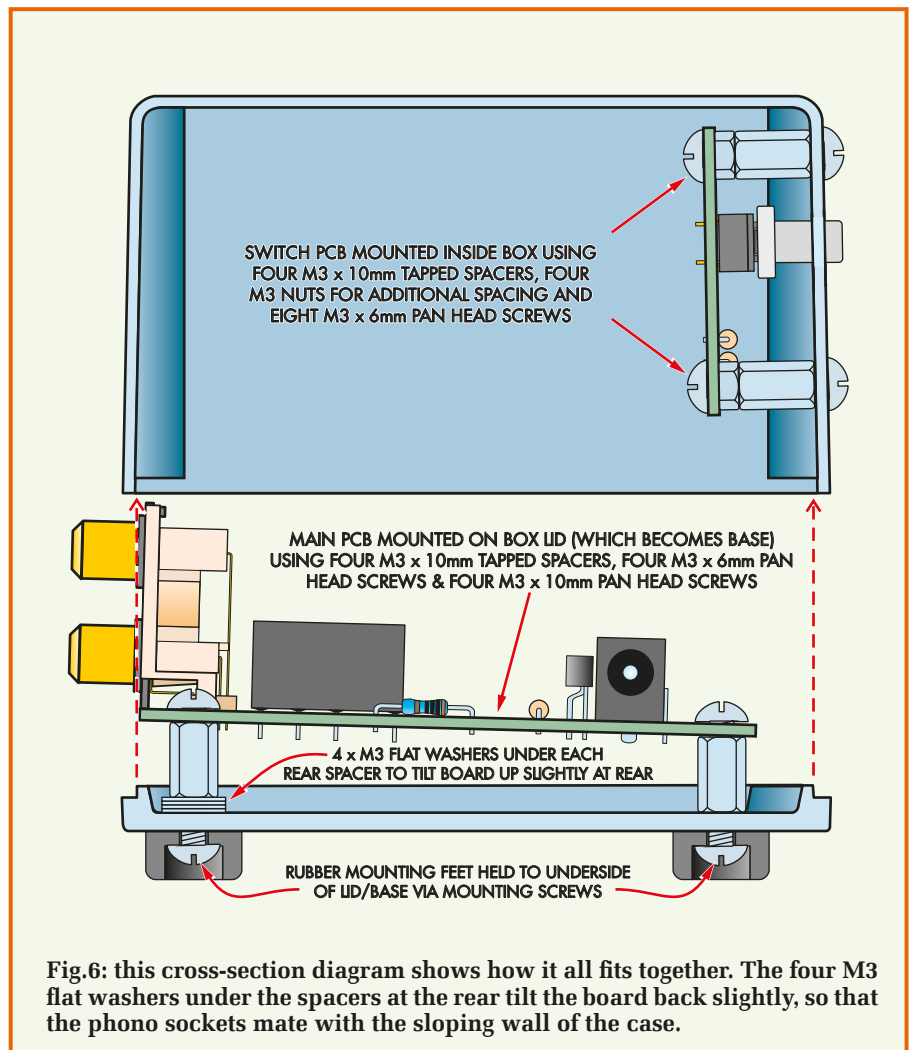

Fig.6: this cross-section diagram shows how it all fits together. The four M3 flat washers under the spacers at the rear tilt the board back slightly, so that the phono sockets mate with the sloping wall of the case.

# World of weirdness

**New Year, new nuttiness – Mark regales you with tall tales of electronic developments that happen to be entirely true**

## What's your council bin up to?

**D**ESPITE its Irish-sounding name, Mic-O-Data is a Dutch technology company specialising in radio frequency identification (RFID) and general packet radio service (GPRS) solutions. One of its latest applications tracks and secures 6,000 refuse bin collection points in public housing estates for 25 Dutch local authorities. These bodies required a solution for securing the collection points and tracking residential refuse collections throughout the country. For this to work effectively the bins needed a wire-free data connection with nationwide coverage.

The solution came from Vodafone, who supplied a cellular radio module for embedding in the refuse bins to transmit a regular status signal once a day. It sends an alert if the bin is getting full, as well as other alerts, such as if the bin has not been closed properly. Each bin is locked and can only be opened by residents issued with an ID card fitted with a security chip. Not only can local authorities monitor who is using the facilities, and bill accordingly, they can also arrange for full bins to be emptied, or additional empty bins to be left.

Vodafone's M2M (machine-to-machine) communication technology enables Mic-O-Data to operate nationwide and offers the scope to expand further into Europe. Already, the local authorities have saved an estimated £75,000 in capital and operational costs.

## Smart metering

As more British homes are fitted with smart electricity and gas meters to save energy, reduce meter reading costs and increase reliability and general transparency, the same M2M technology is providing the datacomms connectivity. Smart meters can also turn on selected home appliances, such as washing machines, when power is least expensive, also turn off selected appliances to reduce demand at peak times.

Vodafone installed remote automated meter reading equipment in its base stations to monitor electricity consumption. The equipment takes a reading every 30 minutes, which is transmitted over their network to a central collection point. The smart

meters paid for themselves in less than a year and saved the company at least £2 million annually on its UK energy bills.

## Energy on a nanoscale

A new power source for energy storage and power generation has been discovered in Australia. The power generated (relative to the energy source size) is three to four times more than what is currently possible with the best lithium-ion batteries.

Professor Kalantar-Zadeh, from the School of Electrical and Computer Engineering at RMIT University in Melbourne, made the breakthrough discovery in a joint project with Professor Michael Strano's nanotechnology research team.

They made the discovery while they were measuring the acceleration of a chemical reaction along carbon nanotubes. The reaction they were monitoring generated power as a by-product. Kalantar-Zadeh said that: 'By coating a nanotube in nitrocellulose fuel and igniting one end, we set off a combustion wave along it and learned that a nanotube is an excellent conductor of heat from burning fuel.'

'Even better, the combustion wave creates a strong electric current. It's the first viable nanoscale approach to power generation that exploits the thermoelectric effect by overcoming the feasibility issues associated with minimising dimensions.'

## Breathing battery combats 'range anxiety'

Another promising energy development has been made by IBM, in which oxygen is reacted with lithium to create lithium peroxide and electrical energy. When the battery is recharged, the process is reversed and oxygen is released again, which explains the 'breathing' tag. The breakthrough is the latest achievement of the corporation's 'Battery 500' initiative, which Big Blue started in 2009 to produce a battery capable of powering a car for 500 miles.

One of the greatest barriers to widespread take-up of electric vehicles is the limited battery range. Although most people favour switching to electric vehicles to save the run on petrochemicals and contribute to a healthier environment, 'range anxiety' – the fear of being stranded with

no power – is cited by 64 percent of drivers as a main detractor to buying an electric vehicle.

Today's lithium-ion battery technology limits electric cars today to roughly a 100-mile range, and the technology stands little chance of being light enough to travel 500 miles on a single charge or cheap enough to be practical for a family car.

Recognising this barrier to electric vehicle adoption, IBM started the Battery 500 project to develop a new type of lithium-air battery. The technology is expected to improve energy density tenfold, dramatically increasing the amount of energy these batteries can generate and store. Earlier this year, IBM researchers gave a successful demonstration of the charge-and-recharge process for lithium-air batteries. By removing the contained oxides as oxygen, the lithium-air battery becomes smaller and lighter. 'The fundamental operation of the battery is no longer in question,' said Winfried Wilcke, for the Battery 500 project, in an interview with [Wired.com](#).

## Solar cells go 3-D

From the golden state in the US comes the news that Solar3D, based in Santa Barbara, has successfully fabricated an initial prototype of a three-dimensional solar cell. The company is taking the 3-D approach to maximise the conversion of sunlight into electricity.

In conventional solar cells, up to 30 per cent of incident sunlight is wasted by being reflected off the surface of the cells, with more lost inside the solar cell materials. Solar3D uses a three-dimensional design to trap sunlight inside micro-photovoltaic structures, where photons 'bounce around' until they are converted into electrons.

An innovative wide-angle light-collection feature on the cell surface allows for the collection of sunlight over a range of angles during the day. This, they claim, will be dramatically more efficient, resulting in a lower cost per watt that will make solar power affordable for the world.

'This is a game-changing result,' said Jim Nelson, CEO of Solar3D. 'Our wide-angle light collection feature allows our 3-D solar cell to collect light at all times of the day, month and year, an attribute unique in the solar world.'

# Win a Microchip MPLAB REAL ICE probe kit

EPE  
EXCLUSIVE

**E**VERYDAY PRACTICAL ELECTRONICS is offering its readers the chance to win a **Microchip MPLAB REAL ICE probe kit** from Microchip. The MPLAB REAL ICE in-circuit emulator system is their next generation high-speed emulator for Microchip Flash DSC and MCU devices. It debugs and programs PIC and dsPIC Flash microcontrollers with the easy-to-use but powerful graphical user interface of the MPLAB integrated development environment (IDE), included with each kit.

The MPLAB REAL ICE probe is connected to the design engineer's PC using a high-speed USB 2.0 interface and is connected to the target with either a connector compatible with the popular MPLAB ICD 2 system (RJ11) or with the new high-speed, noise-tolerant, low-voltage differential signal (LVDS) interconnection (CAT5).

MPLAB REAL ICE is field upgradeable through future firmware downloads in MPLAB IDE. In upcoming releases of MPLAB IDE, new devices will be supported, and new features added.

**MPLAB REAL ICE features include:**

- Real-time execution and real-time trace collection
- Stopwatch
- Real-time watch
- Full hardware debugging: breakpoints, single-step, variable inspect/modify
- Logic probe inputs/outputs (8)
- I/O port trace and SPI trace options for high-speed upload of trace data
- Over-voltage/short-circuit monitor protection
- Low voltage: to 2.0 volts (2.0V to 5.5V range)
- High-speed USB 2.0 communication protocol

**WORTH**  
**\$499.98**  
(approx. £315.00)  
**EACH**



## HOW TO ENTER

For your chance to win the MPLAB REAL ICE probe kit from Microchip, please visit: [www.microchip-comps.com/epe-realice](http://www.microchip-comps.com/epe-realice) and enter your details in the online entry form.

## CLOSING DATE

The closing date for this offer is 31 January 2013

By JOHN CLARKE



# STEREO COMPRESSOR

Do you hate the way the sound level on your TV suddenly jumps during the advert breaks? Or do you find that the sound levels vary widely when switching between digital TV stations? Perhaps you have problems listening to CDs or MP3s in your car, or against the background din during a party? Are the soft parts too soft and the loud parts too loud? This *Stereo Compressor* will solve that problem. It reduces the dynamic range of the signal while still maintaining clean sound. The unit is also ideal for use with PA systems.

## Features and specifications

### Main features

- Stereo compression
- Input level and volume controls
- Power switch and indicator LED
- Several power supply options

### Specifications

Signal-to-noise ratio..... -75dB (20Hz to 20kHz filter) and -79dB 'A' weighted with respect to 1V in and 1V out

THD+N ..... 0.005% with compression disabled; 0.007% @ 10kHz and 2:1 compression; 0.17% @ 1kHz and 2:1 compression; 1.6% @ 100Hz and 2:1 compression

Channel separation ..... 58dB (unweighted)

Frequency response ..... -1.5dB at 10Hz, -3dB at 33kHz

Compression ratio ..... typically 2:1 from +20dB to -20dB input with respect to 0.318V RMS at the compressor input – see Fig.3

Power consumption..... 17mA at 15VDC; 40mA for supplies over 15V; ( $\pm 40$ mA for supplies over  $\pm 15$ V)



Once again, an audio compressor is the answer to this problem.

Not all audio compressors are as effective as this design though. One problem with some units is that they markedly increase the noise at low signal levels due to the much increased gain at those levels. However, this problem is largely avoided in our unit because it features a 'downward expander'. This reduces the gain once the incoming signal drops below a certain level (or threshold point).

As a result, the noise produced is considerably less than that from units that lack downward expansion.

### Presentation

As shown in the photos, the *Stereo Compressor* is housed in a small slimline plastic case. It has two rotary controls, one to adjust the input level (which sets the amount of compression) and the other to adjust the volume (or output level). A power switch and an indicator LED are also included on the front panel. Four RCA phono connectors on the rear panel are used for the inputs and outputs.

Various power supply options are available for the *Stereo Compressor*. It can be powered from AC or DC supplies, eg, a DC or AC plugpack, a 12V battery in a car, or from the supply rails of a power amplifier. Table 2 shows the various options.

### How it works

Let's take a look at the circuit details – see Fig.1. There are two separate signal paths: via IC1a, IC2a and IC3a for the right channel, and via IC1b, IC2b and IC3b for the left channel. These two signal paths are identical, so we'll just describe the operation of the right channel.

The incoming audio signal is AC-coupled to op amp IC1a via a 10 $\mu$ F

**C**OMPACT disc players and many MP3 players give great sound quality, but they usually have a wide dynamic range. That means that the sound level can range from almost inaudible through to very loud, all without touching the volume control.

This can be a problem in noisy environments. For example, in a car, while the loud passages can be heard, the soft parts may well be lost due to road and engine noise. A similar problem can occur with PA systems, where crowd noise can drown out quiet passages in the sound.

In those situations, simply turning up the volume does not solve the problem. While the quiet bits may then be more audible, the loud sections can be ear-shattering and may even overload the amplifier, causing audible distortion.

What we need to do instead is 'compress' the dynamic range of the signal so that the loud parts are not quite so loud and the soft parts are not nearly so quiet. And that's what this *Stereo Compressor* does – it continuously adjusts the signal level by amplifying the quiet passages and attenuating the louder passages, so that the overall volume range is much reduced.

### Listening to TV

A common annoyance for TV viewers is the way the average sound level suddenly jumps during advertising breaks or when you switch between digital stations. Some stations have quite low sound levels, so you have to turn up the volume. Then you switch channels and you get blasted! That's bad enough, but it's much worse if you're listening via headphones.

Again, an audio compressor is the answer, assuming that you're using an external amplifier. By making the volume more constant, it will enable you to set the volume to a level that's comfortable at all times. It sure beats having to hurriedly hit the 'mute' button each time there's an ad break.

### PA systems and mood music

Apart from its use in cars and for listening to TV via headphones, an audio compressor is a 'must-have' item when it comes to PA systems and mood music. That applies whether you want to provide background music at a dinner party, or if you want to pipe music into a PA system at a restaurant. In each case, the problem is the same – all those people talking at once creates a high level of ambient noise which drowns out the soft passages in the music.

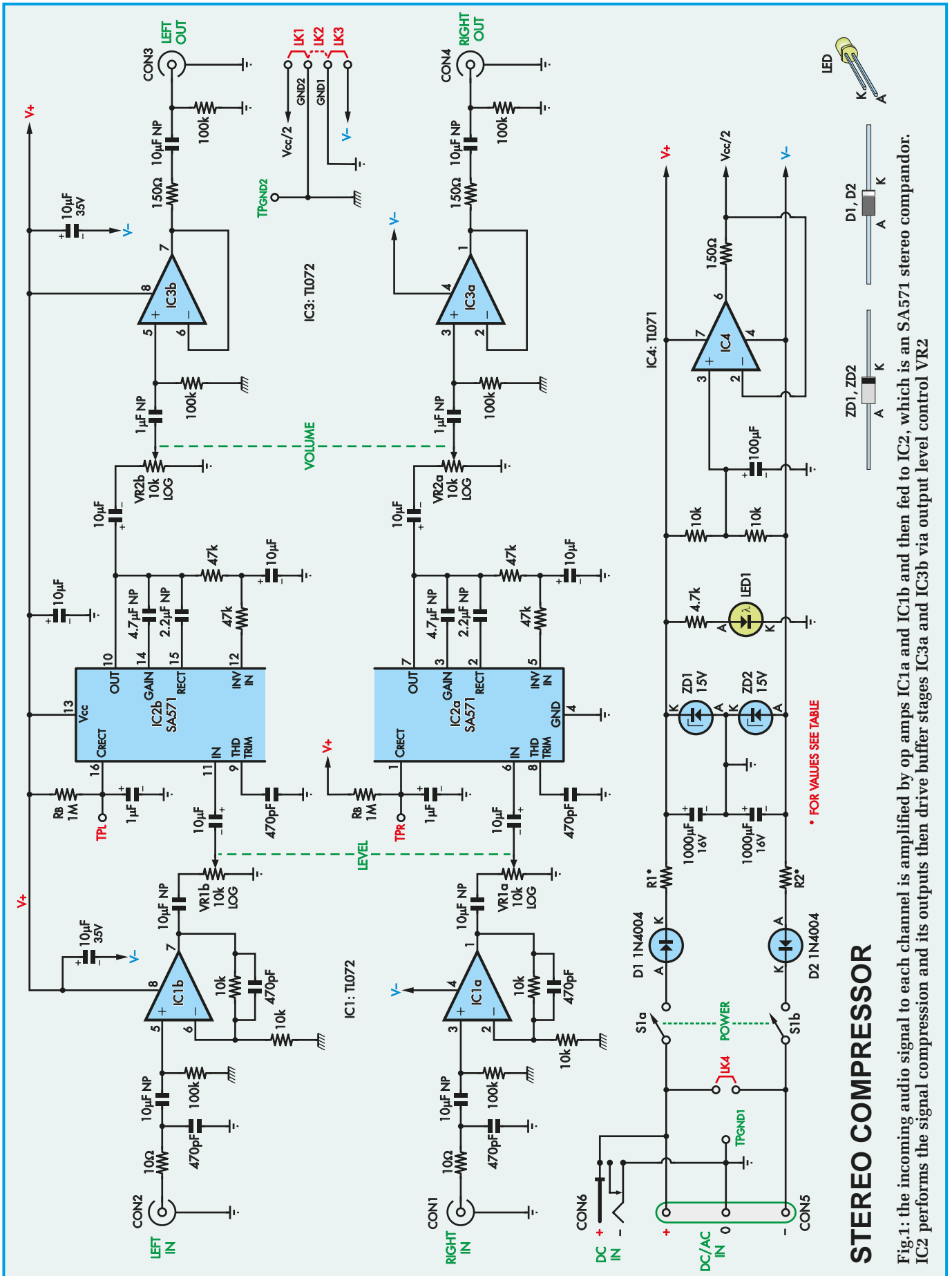



resistor and a 10µF NP (non-polarised) capacitor. A 470pF capacitor bypasses RF (radio frequency) signals to ground, while pin 3 of IC1a is tied to ground via a 100kΩ resistor to set the bias for this stage.

This 100kΩ resistor connects to either the signal ground or to a half-supply ground, depending on the power supply configuration.

In particular, note the two different ground symbols used in the circuit. If a dual-rail (±) supply is used to power the op amp, the bias for IC1a is set to 0V, so that the op amp's output can swing symmetrically above and below 0V. On the other hand, if a single-rail supply is used, the op amp is biased to allow its output to swing above and below the half-supply voltage.

IC1a operates as a non-inverting amplifier with a gain of 2, as set by the 10kΩ feedback resistor between pin 1 and pin 2, and the 10kΩ resistor from pin 2 to ground. The 470pF capacitor across the feedback resistor rolls off the high-frequency response above 33kHz.

IC1a's output is AC-coupled via a 10µF NP capacitor to the top of VR1a. This potentiometer acts as a level control and is adjusted for optimal operation of the following compressor stage based on IC2a.

## Compressor circuit

IC2 is an SA571 stereo compandor IC. The word 'compandor' is a contraction of the words compressor and expander and it means that this IC can be used as either a signal compressor or a signal expander.

In this circuit, the SA571 has been configured to operate as a compressor. Its basic operation is shown in Fig.2 (one channel only shown). It comprises two full-wave averaging rectifiers, two gain elements and a dual op amp for stereo applications.

When used as a compressor, the gain element is placed in the feedback loop, between the op amp's output and its inverting input. The input signal is applied to the inverting input via a 20kΩ resistor (R3), while the non-inverting input is biased above ground to allow a symmetrical output swing.

In practice, the op amp's output is biased to  $(1 + (2R_{DC} / R4)) \times V_{ref}$ .  $V_{ref}$  is about 1.8V, R4 is 30kΩ and the external  $R_{DC}$  resistors in our circuit are 47kΩ. As a result, the op amp's output sits at about 7.44V.

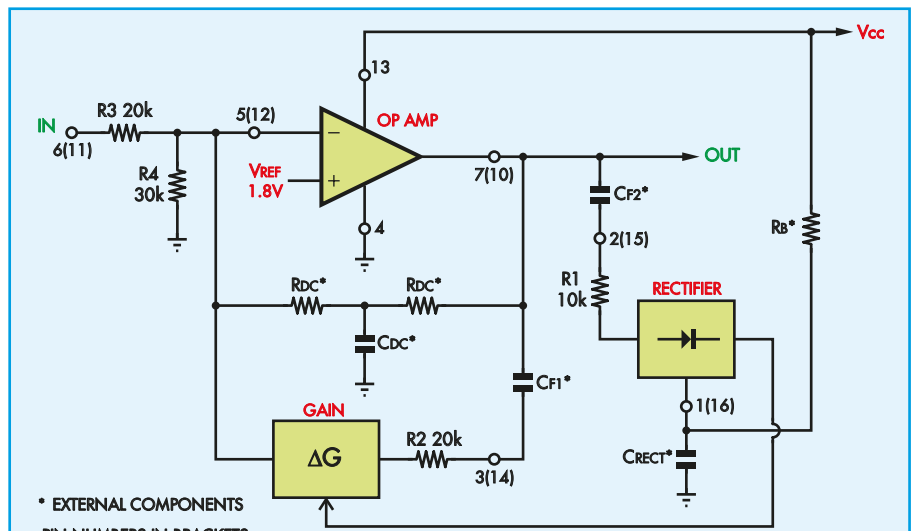

**Fig.2: the basic configuration of each compressor stage inside IC2. The gain element is placed in the feedback network of the op amp and is controlled by the filtered output from the rectifier**

**Fig.3: this graph plots the compressor's output as a function of its input signal. It provides a nominal 2:1 compression, but it has a non-linear response with resistor  $R_B$  in (see text)**

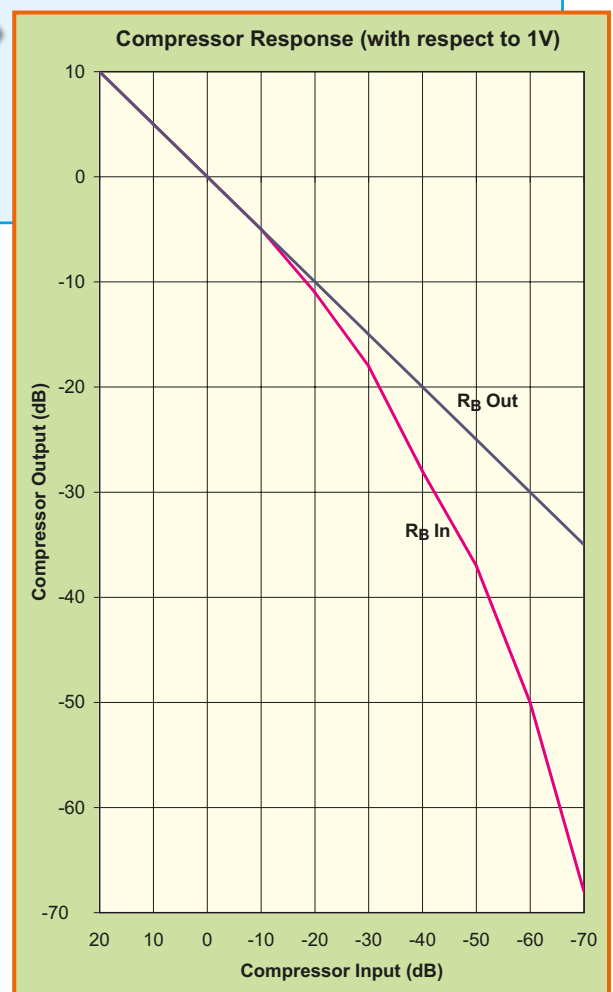

During operation, the full-wave averaging filter monitors the op amp's output and rectifies the signal. This rectified signal is then averaged (smoothed) to provide a DC voltage that controls the gain element. If the signal level is low, then the DC control voltage is low and the gain element's resistance is high. As a result, the op amp operates with high gain and so low-level signals are boosted.

Conversely, if the input signal level is high, the control voltage is also high and this reduces the gain element's resistance to lower the gain. So the overall effect is that low-level signals are boosted while high level signals are reduced.

Fig.3 plots the compressor's output against its input signal level. It's set up to provide a nominal 2:1 compression. Note, however, that at low signal levels the gain increase is non-linear and is reduced,

due to the addition of resistor  $R_B$ . Without this resistor, the compressor would operate with a nominal 2:1 compression for signals right down to -80dB (ie, 80dB below the 0dB

# Constructional Project

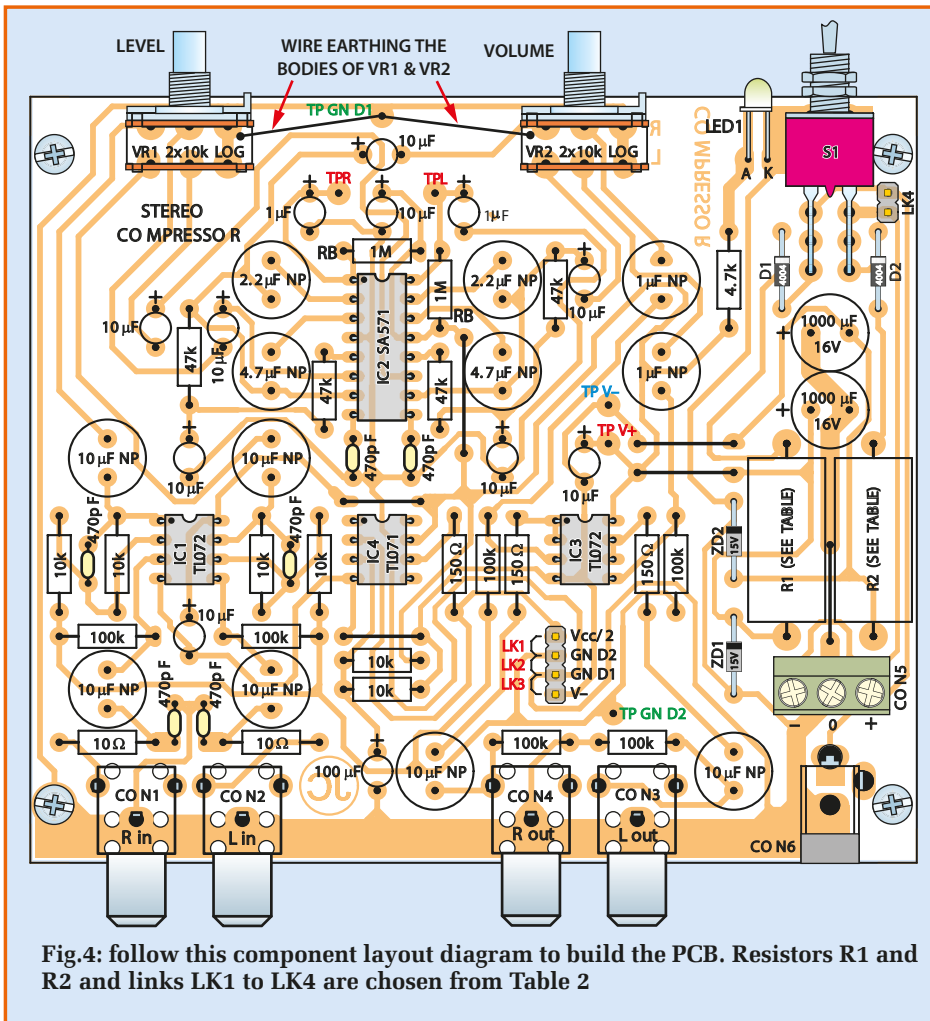

reference) and this would lead to a significant increase in noise.

The SA571 requires only a few external parts to produce a working compressor stage. As shown in Fig.1, the signal from VR1a's wiper is AC-coupled to IC2a's pin 6 input, while the output at pin 7 is AC-coupled to the gain cell at pin 3 and the rectifier at pin 2. The two associated 47kΩ resistors are in the feedback path between the internal op amp's output (pin 7) and its inverting input (pin 5) and are the  $R_{DC}$  resistors shown in Fig.2.

The smoothing (averaging) capacitor for the rectifier is at pin 1, while resistor  $R_B$  (1MΩ) is connected to the V+ rail to provide non-linear compression at low levels (to reduce noise). A 470pF capacitor is used to decouple the distortion trim input at pin 8 (this input is not used here).

IC2a's output at pin 7 is AC-coupled to volume control VR2a. This sets the signal level applied to output buffer stage IC3a. IC3a's pin 3 input is biased using a 100kΩ resistor to ground. As

before, this ground point can be set to either 0V or to half-supply, depending on the power supply used.

IC3a operates as a unity-gain buffer stage. Its output appears at pin 1 and this is then fed to output socket CON4 via a 150Ω resistor and a 10μF NP capacitor. The 150Ω resistor isolates IC3a's output from the capacitance of the output leads, to prevent instability.

## Power supply

Power for the circuit can come from either a 12V to 30V DC source, a ±12V to 25V DC source or an 11V to 25V AC source. The current consumption is about 40mA.

The simplest supply arrangement is to use a ±12V to 30V DC source (ie, a dual-rail supply, as often found in stereo amplifiers). This is fed into CON5 and switched by S1a and S1b. Diodes D1 and D2 provide reverse polarity protection, and the following 1000μF capacitors filter the supply rails to reduce ripple.

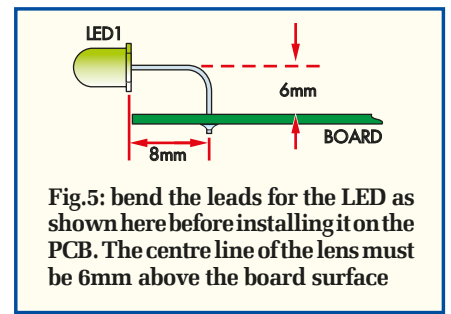

Zener diodes ZD1 and ZD2 limit the supply rails to ±15V, while resistors R1 and R2 limit the current through ZD1 and ZD2. The values of these resistors depend on the external supply voltage and are chosen from Table 2.

With this supply arrangement, the two different grounds on the circuit are tied together using link LK2 (see Table 2). This biases the op amp inputs at 0V so that the signal swings symmetrically above and below ground.

## Using an AC supply

An 11V to 25V AC supply can also be used to derive dual (±) supply rails. In this case, the '+' and '-' rails are connected together immediately following CON5 using link LK4. One side of the AC supply then goes to 0V, while the other goes to either the '+' input or the '-' input. Alternatively, the AC supply can be fed in via CON6.

With this supply configuration, diodes D1 and D2 function as half-wave rectifiers, with filtering again provided by the two 1000μF capacitors. Diode D1 conducts on the positive half-cycles to produce the positive rail, while D2 conducts on the negative half-cycles to produce the negative rail.

As before, the two grounds (GND1 and GND2) are connected using link LK2, and current-limiting resistors R1 and R2 are selected using Table 2.

## 12V to 30V DC supply

The arrangement is a bit more complicated for a 12V to 30V DC supply. That's because the signal can no longer swing below the 0V rail, since there's no negative supply. As a result, the op amps must be biased to a half-supply voltage, so that the signal can swing symmetrically about this voltage.

This half-supply voltage is derived using a voltage divider consisting of two 10kΩ resistors between the positive supply rail and ground. A 100μF capacitor filters this half-supply

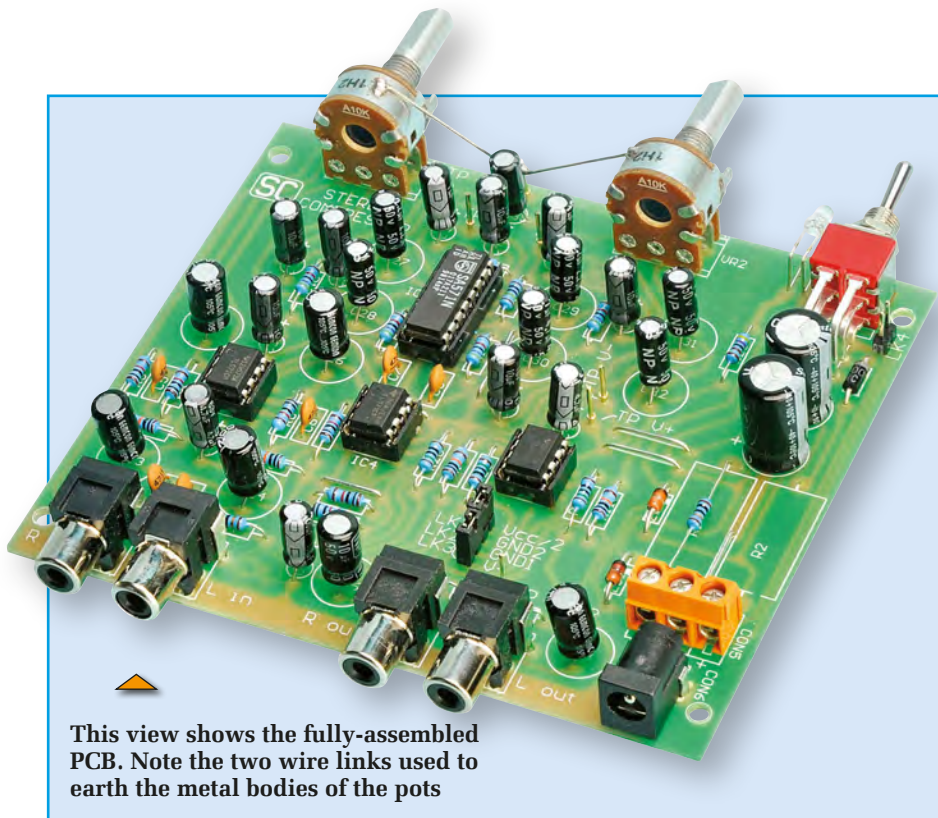

This view shows the fully-assembled PCB. Note the two wire links used to earth the metal bodies of the pots

rail and this is then fed to the non-inverting input (pin 3) of IC4.

IC4 is wired as a unity-gain buffer stage. Its output at pin 6 provides the half supply via a 150Ω decoupling resistor. This half-supply rail is then used to bias op amps IC1 and IC2.

In this case, links LK1 and LK3 are used (but not LK2). LK1 connects the half-supply rail to the op amp signal grounds, while LK3 connects the op amp negative supply pins to the power supply ground.

The supply itself is connected between the '+' and the 0V (ground) terminals of CON5, or it can be fed in via CON6.

Regardless of the power supply configuration used, LED1 lights when power is applied via on/off switch S1. This LED is powered from the nominal +15V rail via a 4.7kΩ current-limiting resistor (note: this rail will be at +12V if a 12V DC supply is used).

The AC-coupling capacitors at the inputs and outputs of the op amps remove any DC component from the signal. In particular, they are necessary when the op amp outputs are biased to half supply. For the other supply options, the capacitors prevent DC coupling to the input stages of IC1a and IC1b and prevent DC flow in the level and volume controls (which would cause noise).

## Construction

The assembly is straightforward, with all components mounted on a printed circuit board (PCB) measuring 118mm × 102mm. This PCB board is available from the *EPE PCB Service*, code 833. The board is housed in a plastic instrument case measuring 140mm × 110mm × 35mm.

Replacement front and rear panels can be purchased from Silicon Chip ([www.siliconchip.com.au](http://www.siliconchip.com.au)) at a cost of \$20 (Aus), plus postage. They are screen printed, are mechanically robust, look good and the holes are all pre-drilled. Alternatively, you can try Beta Layout's new panel service – visit: [www.panel-pool.com/fpuk/service\\_downloads.html](http://www.panel-pool.com/fpuk/service_downloads.html) for a quotation.

The main PCB is designed to mount on to integral bushes within the specified box. Make sure the board fits correctly within the box and that the mounting holes line up with these bushes. The corner mounting holes should all be 3mm in diameter.

Fig.4 shows the component layout on the PCB. Begin by checking the PCB for any defects (rare these days), then install the six wire links and the resistors. Leave R1 and R2 out for the moment, but don't forget the link between them. You should use a digital multimeter to check the value of each resistor before installation on the printed circuit board.

Diodes D1 and D2 and Zener diodes ZD1 and ZD2 can go in next. These must be correctly oriented. Follow with PC stakes at the six test points (TP V+, TP V–, TPL, TPR, TP GND1 and TP GND2) and the 2-way (LK4) and 4-way (LK1 to LK3) pin headers.

The four ICs are next on the list. These can either be soldered direct to the PCB or mounted via 8-pin and 16-pin IC sockets. Take care with their orientation – the ICs all face in the same direction. Note also that IC1 and IC3 are both TL072s, while IC4 is a TL071 – don't get them mixed up.

Now for the capacitors. Install the ceramic capacitors first before moving on to the larger electrolytics. The 10μF 'NP' (non-polarised) capacitors can be mounted either way around, but the remaining electrolytics must all be installed with the correct polarity.

## Hardware installation

The larger hardware items can now be installed. These include switch S1, the two pots, the four RCA phono sockets and one of the power supply sockets (CON5 or CON6). Install CON6 if you intend using either a single rail DC supply or an AC supply.

Alternatively, install CON5 instead if you intend using a dual-rail supply (ie, with '±' rails). A grommet is then installed at CON6's location on the rear panel so that the external supply leads can be fed in.

Before mounting the two pots, trim their shafts (using a hacksaw) to suit the knobs (about 13mm for the knobs specified). The pots are then pushed down so that they sit flush against the PCB and their leads are soldered.

Once they are in position, solder a length of tinned copper wire between each pot body and TP GND1. Note that it will be necessary to scrape away some of the coating from the pot bodies to get the solder to adhere. You will also need to wind up the temperature of your soldering iron if you have a soldering station.

## Installing the LED

LED1 is installed by first bending its leads down through 90° about 8mm from its body. Do check that it is correctly oriented before you do this (see Fig.5). The LED is then installed so that the centre of its lens is 6mm above the board, so that it will later protrude through its hole in the front panel.

# Constructional Project

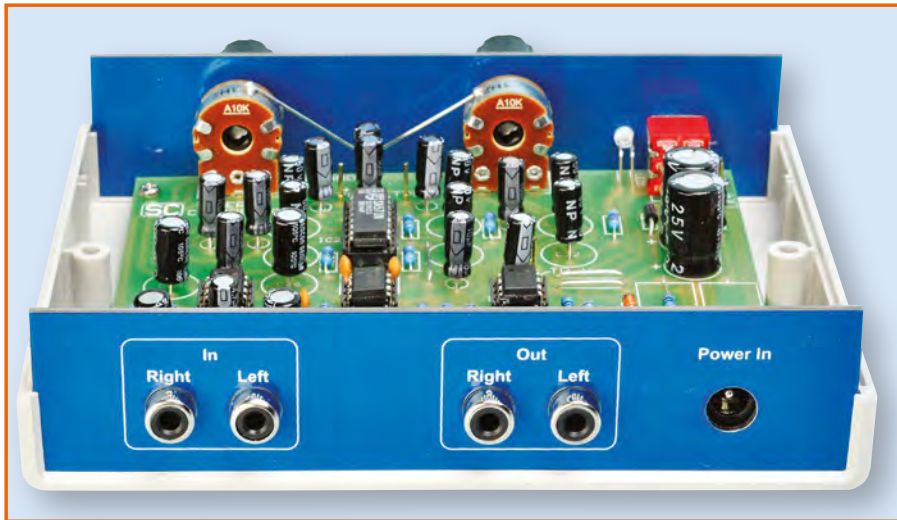

The rear panel provides access to the input and output RCA phono sockets, as well as to the power socket. Omit the power socket and fit a rubber grommet if you intend using a dual-rail supply

A 6mm-high cardboard spacer or some other suitable 6mm spacer will make this job easier.

## Power resistors and links

Resistors R1 and R2 can now be installed, depending on the power supply to be used with the device. Table 1 shows the resistor values for the various supply voltages.

Links LK1 to LK4 (in the form of jumper shunts) must also be selected and installed according to the power supply:

- For a dual-rail supply, install LK2 and omit LK4

- For an AC supply, install both LK2 and LK4
- For a single-rail DC supply, install LK1 and LK3 and omit LK4.

## Final assembly

With the PCB assembly now complete, it can be installed in its plastic case. Before doing this though, it will be necessary to remove the surplus mounting posts on the base, since they will foul the component leads under the PCB. This can be done by twisting them off using pliers, but be sure to leave the four corner posts.

The front and rear replacement panels can now be slipped into place (ie, at the front and rear of the main PCB), then slot the assembly into the case and install the four self-tapping screws at the corners.

The assembly can now be completed by fitting the nuts to the pots and switch S1 and pushing the two knobs onto the pot shafts. Leave the lid off for the time being – it will be attached after the unit has been tested.

## Connecting a power supply

The supply connections depend on the type of power supply used:

- If you have a dual-rail (split) DC power supply, connect it to the '+', '0' and '-' terminals of CON5
- If you have an AC supply or a single-rail DC supply (eg, a plugpack), connect it to the '+' and '0' terminals of CON5, or feed it in via CON6.

## Testing

To test the unit, apply power and check that the power LED lights. If it doesn't, check the supply polarity and check that the LED is correctly oriented.

Assuming all is well, the next step is to check the power supply voltages on the board. These will vary according to the supply used. For a single-rail DC supply, the voltage between pin 8 and pin 4 of both IC1 and IC3, and between pin 7 and pin 4 of IC4 should be at about 15V (note: this will be lower if the DC supply is less than 15V). In addition, the voltage between TP GND2 and TP GND1 should be 7.5V for a 15V supply (ie, half the supply voltage).

Now check the voltage on pin 13 of IC2. It should be at +15V (or less if a lower supply voltage is used).

If you are using a dual-rail supply, the voltages should be measured with respect to the 0V rail at TP GND1. In this case, pin 8 of both IC1 and IC3, pin 13 of IC2 and pin 7 of IC4 should be at +15V. Similarly, pin 4 of IC1, IC3 and IC4 should all be at -15V.

Once again, these voltages will be correspondingly lower if lower supply voltages are used.

## Using it

The *Stereo Compressor* is designed to accept line level signals (ie, 774mV

**Table 1: Choosing R1 and R2, setting the supply links**

Input voltage	R1	R2	Links	Power input
±25VDC	270Ω 5W	270Ω 5W	LK2 in, LK4 out	+, 0, -
±20VDC	120Ω 1W	120Ω 1W	LK2 in, LK4 out	+, 0, -
±15VDC	10Ω 1/2W	10Ω 1/2W	LK2 in, LK4 out	+, 0, -
±12VDC	10Ω 1/2W	10Ω 1/2W	LK2 in, LK4 out	+, 0, -
25VAC	470Ω 5W	470Ω 5W	LK2 and LK4 in	+, 0 or CON6
20VAC	390Ω 5W	390Ω 5W	LK2 and LK4 in	+, 0 or CON6
18VAC	270Ω 5W	270Ω 5W	LK2 and LK4 in	+, 0 or CON6
15VAC	120Ω 1W	120Ω 1W	LK2 and LK4 in	+, 0 or CON6
11VAC	10Ω 1/2W	10Ω 1/2W	LK2 and LK4 in	+, 0 or CON6
+30VDC	390Ω 5W	NA	LK1 and LK3 in, LK4 out	+, 0 or CON6
+25VDC	270Ω 5W	NA	LK1 and LK3 in, LK4 out	+, 0 or CON6
+20VDC	120Ω 1W	NA	LK1 and LK3 in, LK4 out	+, 0 or CON6
+15VDC	10Ω 1/2W	NA	LK1 and LK3 in, LK4 out	+, 0 or CON6
+12VDC	10Ω 1/2W	NA	LK1 and LK3 in, LK4 out	+, 0 or CON6

## Parts List – Stereo Compressor

- 1 PCB, code 833, available from the *EPE PCB Service*, size 118mm × 102mm
- 1 Pair of front and rear panels available from Silicon Chip ([www.siliconchip.com.au](http://www.siliconchip.com.au)) or Beta Layout ([www.panel-pool.com/fpuk/service\\_downloads.html](http://www.panel-pool.com/fpuk/service_downloads.html)) – see text
- 1 instrument case, 140mm × 110mm × 35mm
- 4 PCB-mount single right-angle RCA sockets (CON1 to CON4)
- 1 3-way screw terminal block, 5.04mm pitch (CON5)
- 1 PCB-mount DC socket (CON6)
- 1 DPDT PCB-mount right angle toggle switch (S1)
- 3 8 pin IC sockets (optional)
- 1 16 pin IC socket (optional)
- 1 4-way pin header strip
- 1 2-way pin header strip
- 2 jumper shunts
- 1 200mm length of 0.7mm tinned copper wire
- 4 No.4 × 6mm self-tapping screws
- 6 PC stakes

### Semiconductors

- 2 TL072 dual op amps (IC1, IC3)
- 1 SA571N Comparator (IC2) (available from Futurelec)
- 1 TL071 single op amp (IC4)
- 2 1N4004 diodes (D1, D2)
- 2 15V 1W Zener diodes (ZD1, ZD2)
- 1 3mm green LED (LED1)

### Capacitors

- 2 1000µF 16V PC electrolytic
- 1 100µF 16V PC electrolytic
- 6 10µF NP PC electrolytic
- 9 10µF 35V PC electrolytic
- 2 4.7µF NP PC electrolytic
- 2 2.2µF NP PC electrolytic
- 2 1µF NP PC electrolytic
- 2 1µF 16V PC electrolytic
- 6 470pF ceramic

### Resistors (0.25W, 1%)

- 2 1MΩ      1 4.7kΩ
- 6 100kΩ    3 150Ω
- 4 47kΩ     2 10Ω
- 6 10kΩ     R1, R2 (see Table 2)
- 2 dual 10kΩ log 16mm potentiometers (VR1, VR2)

## Compression and distortion compromises

If we feed a sine wave into the compressor, the amount by which it is distorted depends on its frequency. Lower frequencies suffer much greater distortion. The reason is that for low frequencies, the compressor actually responds to the slow changes in signal amplitude by changing its gain. After all, that is the job of the compressor.

We can reduce the amount of low-frequency distortion by using longer attack and decay times. That way, the compressor doesn't react so quickly to changes in signal level and so low frequencies are passed through more cleanly. But this impacts the function of the compressor and can result in undesirable behaviour, such as 'ramping' of the volume level over time. It also limits the extent to which the compressor can deal with sudden, loud sounds, such as microphone thumps.

So the filter components have been chosen for the best balance between distortion and compression response time. The action of the compressor in dynamically varying its gain inevitably distorts the signal.

In practice, music signals are much more complex than a simple sine wave and the distortion will be lower than the figures suggest.

RMS). In addition, Level control VR1 must be adjusted so that the compressor stage operates correctly, while VR2 functions as an output level (or Volume) control.

In theory, VR1 should be set so that there is an average of 1.8V DC between TPL and TP GND1 for a typical signal into the left channel and 1.8V DC between TPR and TP GND1 for the right channel (note: a 'typical signal' is the program material that will normally be fed into the unit). It's just a matter of feeding in a suitable signal and adjusting the Level control while monitoring these test points using a multimeter.

If the voltage at these test points is significantly less than 1.8V with VR1 set to maximum, then the gain of op

amp stages IC1a and IC1b will have to be increased. This is done by reducing the 10kΩ resistor between pin 2 and ground for IC1a and between pin 6 and ground for IC1b.

Once the signal levels are correct, the unit can be tested by connecting it to an amplifier and feeding in an audio signal. The volume control can then be adjusted to set the output level, while the level control will normally be left unchanged from its previous setting, but can be tweaked to alter the compression curve if necessary. **EPE**

Reproduced by arrangement with SILICON CHIP magazine 2012.  
[www.siliconchip.com.au](http://www.siliconchip.com.au)





We design and manufacture a range of transformers

- Mains Transformers
- Valve output
- Chokes and Inductors
- Custom and Specials

Tel: 01983 880054  
vvt.office@gmail.com

**[www.vvttransformers.co.uk](http://www.vvttransformers.co.uk)**  
Variable Voltage Technology Ltd, Unit 3B Sheat Farm,  
Chillerton, Isle of Wight, PO30 3HP

We can supply back issues of *EPE* by post, most issues from the past five years are available. An *EPE* index for the last five years is also available at [www.epemag.com](http://www.epemag.com). Where we are unable to provide a back issue a photocopy of any one article (or one part of a series) can be purchased for the same price. Issues from Jan. 99 are available on CD-ROM or DVD-ROM – and back issues from recent years are also available to download from [www.epemag.com](http://www.epemag.com). Please make sure all components are still available before commencing any project from a back-dated issue.

## DID YOU MISS THESE?



## BACK ISSUES ONLY £5.00 (each inc. UK p&p.)

Overseas prices £5.80 each surface mail, £6.80 each airmail.

We can also supply issues from years: 2006 (except Jan., Feb., Mar., Apr., May, July), 2007 (except June, July, Aug), 2008 (except Aug, Nov, Dec) 2009 (except Jan, Mar, Apr), 2010 (except May, June, July, August, Oct, Nov, Dec) 2011 (except Jan).

Where we do not have an issue a photocopy of any **one article** or **one part** of a series can be provided at the same price.

### NOV '11

**PROJECTS** • Digital Capacitor Leakage Meter • One-of-Nine Switch Indicator • Using A Wideband O2 Sensor In Your Car – Part 1 • Build A High-Quality Stereo DAC For Superb Sound From Your DVD Player – Part 3  
**FEATURES** • Techno Talk • Practically Speaking • Circuit Surgery • Max's Cool Beans • Net Work.

### DEC '11

**PROJECTS** • WIB – WebServer In A Box – Part 1 • Ginormous 7-segment LED Panel Meter Display • Using A Wideband O2 Sensor In Your Car – Part 2  
**FEATURES** • Techno Talk • Interface • Circuit Surgery • PIC N' Mix • Max's Cool Beans • Net Work.

### JAN '12

**PROJECTS** • GPS Car Computer – Part 1 • WIB – WebServer In A Box – Part 2 • A Balanced Output Board For The Stereo DAC • Ingenuity Unlimited  
**FEATURES** • Techno Talk • Practically Speaking • Circuit Surgery • Recycle It! • Net Work.

### FEB '12

**PROJECTS** • Air Quality Monitor • GPS Car Computer – Part 2 • WIB – WebServer In A Box – Part 3 plus Add-on • Programming PICs: How It's Done • Ingenuity Unlimited  
**FEATURES** • Recycle It! • Techno Talk • Interface • Circuit Surgery • PIC N' Mix • Net Work.

### MAR '12

**PROJECTS** • High-Quality Digital Audio Signal Generator – Part 1 • Accurate Thermometer/Thermostat • Internet Time Display Module (WIB) • Solar-Powered Intruder Alarm • Ingenuity Unlimited  
**FEATURES** • Techno Talk • Practically Speaking • Max's Cool Beans • PIC N' Mix • Net Work.

### APR '12

**PROJECTS** • EHT Stick • High-Quality Digital Audio Signal Generator – Part 2 • Capacitor Leakage Adaptor For DMMs • WIB FAQs  
**FEATURES** • Techno Talk • Circuit Surgery • Interface • Max's Cool Beans • PIC N' Mix • Net Work.

### MAY '12

**PROJECTS** • Compact High-Performance 12V Stereo Amplifier • High-Quality Digital Audio Signal Generator – Part 3 • Low-Power Car/Bike USB Charger • Solar-Powered Lighting Controller – Part 1  
**FEATURES** • Techno Talk • Jump Start – Moisture Detector • Circuit Surgery • Practically Speaking • PIC N' Mix • Net Work.

### JUNE '12

**PROJECTS** • Digital Insulation Meter • Dual Tracking ± 0V To 19V Power Supply – Part 1 •

Low-Power Car/Bike USB Charger • Solar-Powered Lighting Controller – Part 2  
**FEATURES** • Jump Start – Quiz Machine • Techno Talk • Pico 2205 MSO PC oscilloscope • PIC N' Mix • Circuit Surgery • Interface • Net Work.

### JULY '12

**PROJECTS** • Lab-Standard 16-Bit Digital Potentiometer • Intelligent 12V Fan Controller • Dual Tracking ±0V To 19V Power Supply – Part 2 •  
**FEATURES** • Jump Start – Battery Voltage Checker • Techno Talk • PIC N' Mix • Circuit Surgery • Practically Speaking • Max's Cool Beans • Net Work.

### AUG '12

**PROJECTS** • Ultrasonic Cleaner • Electrolytic Capacitor Reformer and Tester – Part 1 • High-Performance Microphone Preamplifier • High-Power Reversible DC Motor Speed Controller  
**FEATURES** • Jump Start – Solar-Powered Charger • Raspberry Pi Review • Techno Talk • PIC N' Mix • Circuit Surgery • Interface • Net Work.

### SEPT '12

**PROJECTS** • Designing And Installing A Hearing Loop For The Deaf • Hearing Loop Receiver • Ultrasonic Anti-Fouling For Boats – Part 1 • Electrolytic Capacitor Reformer and Tester – Part 2  
**FEATURES** • Jump Start – Versatile Theft Alarm •

Raspberry Pi – Real-Time Clock • PIC N' Mix • Circuit Surgery • Practically Speaking • Net Work.

### OCT '12

**PROJECTS** • Two TOSLINK-S/PDIF Audio Converters • Digital Lighting Controller – Part 1 • Ultrasonic Anti-Fouling For Boats – Part 2 • Designing And Installing A Hearing Loop For The Deaf – Part 2 • Ingenuity Unlimited  
**FEATURES** • Jump Start – Spooky Circuits • Techno Talk • Interface • Circuit Surgery • Max's Cool Beans • Net Work.

### NOV '12

**PROJECTS** • Hearing Loop Level Meter – Part 1 • Digital Lighting Controller – Part 2 • RFID Security System • Easy USB *plus* Telescope Driver Control • Ingenuity Unlimited  
**FEATURES** • Jump Start – Frost Alarm • Techno Talk • Review – Picoscope 3406B • Practically Speaking • Circuit Surgery • Max's Cool Beans • Net Work.

### DEC '12

**PROJECTS** • Universal USB Data Logger – Part 1 • Hot-Wire Cutter • Digital Lighting Controller – Part 3 • Hearing Loop Level Meter – Part 2 • Ingenuity Unlimited  
**FEATURES** • Jump Start – Mini Christmas Lights • Techno Talk • PIC N' Mix • Circuit Surgery • Interface • Max's Cool Beans • Net Work.

## ORDER FORM – BACK ISSUES – PHOTOCOPIES – INDEXES

Send back issues dated.....

Send photocopies of (article title and issue date) .....

Name .....

Address.....

Tel: .....

I enclose cheque/P.O./bank draft to the value of £ .....

Please charge my Visa/Mastercard/Maestro £ .....

Card No ..... Maestro Issue No .....

Valid From ..... Card Expiry Date ..... Card Security Code .....

(The last 3 digits on or just under the signature strip)

SEND TO: **Everyday Practical Electronics, Wimborne Publishing Ltd., 113 Lynwood Drive, Merley, Wimborne, Dorset BH21 1UU.**

Tel: 01202 880299. Fax: 01202 843233.

E-mail: [orders@epemag.wimborne.co.uk](mailto:orders@epemag.wimborne.co.uk) On-line Shop: [www.epemag.com](http://www.epemag.com)

Payments must be in £ sterling – cheque or bank draft drawn on a UK bank. Normally posted within seven days of receipt of order. Send a copy of this form, or order by letter if you do not wish to cut your issue.





\$49<sup>00</sup>

# one SOCKET



# for ALL click boards

Just place the Click™ board you need into the innovative new mikroBUS™ socket and it's ready to work right away.



\$18<sup>00</sup>

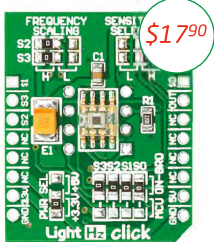

\$17<sup>90</sup>

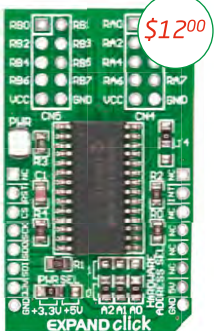

\$12<sup>00</sup>



\$10<sup>00</sup>



\$16<sup>90</sup>



\$16<sup>00</sup>

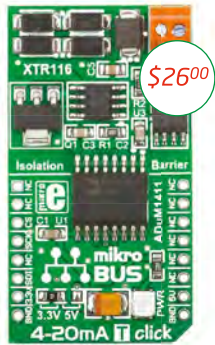

\$26<sup>00</sup>



\$25<sup>90</sup>



\$21<sup>00</sup>



\$9<sup>00</sup>



\$45<sup>00</sup>



\$19<sup>00</sup>



\$49<sup>00</sup>

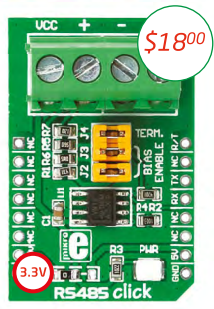

\$18<sup>00</sup>



\$15<sup>00</sup>



\$41<sup>90</sup>

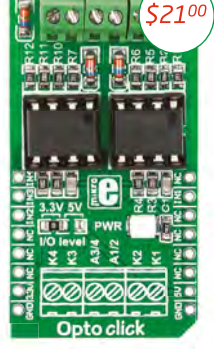

\$21<sup>00</sup>



\$29<sup>00</sup>



\$21<sup>90</sup>

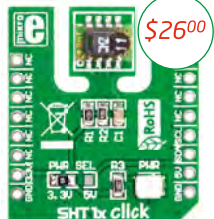

\$26<sup>00</sup>

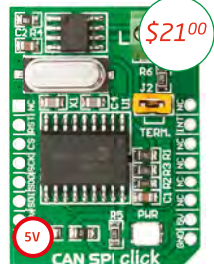

\$21<sup>00</sup>



\$29<sup>00</sup>



\$13<sup>90</sup>

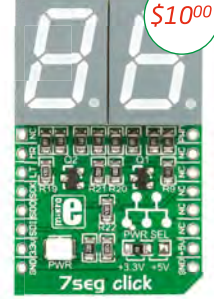

\$10<sup>00</sup>

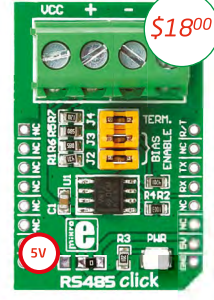

\$18<sup>00</sup>



\$8<sup>00</sup>

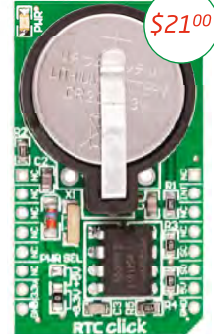

\$21<sup>00</sup>

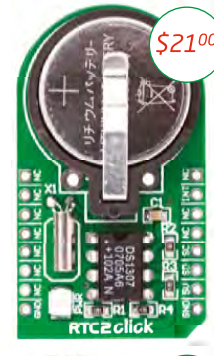

\$21<sup>00</sup>



\$44<sup>00</sup>



\$19<sup>00</sup>



\$24<sup>00</sup>



\$13<sup>90</sup>

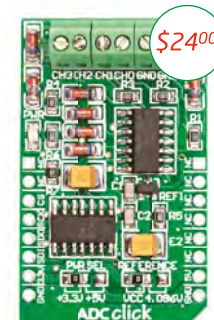

\$24<sup>00</sup>

# Low-Capacitance Adaptor for DMMs

This neat little *Adaptor* allows a standard digital multimeter to measure low values of capacitance – from less than one picofarad to over 10nF. It will allow you to measure tiny capacitors or stray capacitances in switches, connectors and wiring.

By JIM ROWE

ALTHOUGH some modern digital multimeters do provide capacitance measuring ranges, these are generally not particularly useful when it comes to measuring low-value capacitors or the stray capacitance associated with connectors, switches and other components.

For most of these small capacitance measurements, you normally need to use a dedicated low-value capacitance meter – and these can be pricey.

This *Adaptor* is easy to build, with all of the components mounted on a small PC board. The board fits into a box which is small enough to be used as a dedicated ‘low-capacitance probe’ for the DMM, making it well suited for measuring stray capacitances. Just about any modern DMM is suitable for the *Low-Capacitance Adaptor*, provided it has an input resistance of 10M $\Omega$  or 20M $\Omega$ .

## How it works

Essentially, the *Adaptor* works as a capacitance-to-DC voltage converter, as shown in Fig. 1.

First we generate a square-wave clock signal with a frequency of between 110kHz and 1.1kHz (depending on the measuring range) using a simple relaxation oscillator based on capacitor C1, resistor R1, trimpot VR1 and a Schmitt trigger inverter. This square-wave signal is then passed through a Schmitt buffer stage to square it up and produce a waveform with very fast rise and fall times.





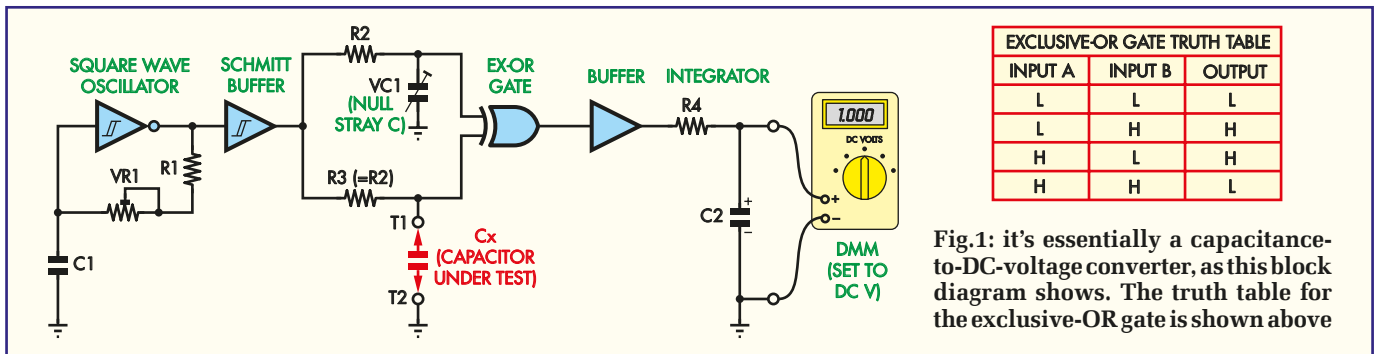

The output signal from the Schmitt buffer is then split two ways and passed through identical resistors R2 and R3. Then they are fed to the two inputs of an exclusive-OR (XOR) gate. The signal which passes through R2 sees a small trimmer capacitor (VC1) connected from the output end of R2 to ground, while the signal which passes through R3 has the capacitance which is to be measured connected from the output end of R3 to ground (ie, between terminals T1 and T2).

So each signal is fed to the inputs of the XOR gate via an RC delay circuit. The combination of these two RC delay circuits and the XOR gate forms a simple time delay comparator.

Remember that when both inputs of an XOR gate are at the same logic level (either high or low), its output is low. And whenever the two inputs are at different logic levels, its output switches high. This is summarised in the truth table associated with Fig.1.

### Through the gate

Now consider the situation where there is no discrete capacitor connected between the test terminals, so there will only be a small 'stray' capacitance between them. As

a result, there will only be a very short delay in the signal passing through R3 to the lower input of the XOR gate.

If trimmer VC1 is set to provide the same low capacitance for the signal passing through resistor R2, the two signals applied to the inputs of the XOR gate will be delayed by the same amount of time and so will arrive at the gate inputs in sync – rising and falling at exactly the same times.

In this situation, the output of the XOR gate will remain low at all times, because both inputs of the gate are always high or low, both switching together between the two levels. But when we connect an unknown capacitor (Cx) between terminals T1 and T2, the signal passing through R3 will be delayed more than the signal passing through R2.

So now the lower gate input will switch high and low a short time after the upper input, and as a result, the logic levels of the two gate inputs will be different for short periods of time following each high-low or low-high transition of the square-wave signal.

The XOR gate's output will switch high during these transition delays, generating a series of positive-going pulses, with their width directly proportional to the extra delay time caused by the unknown capacitor Cx. In fact, the

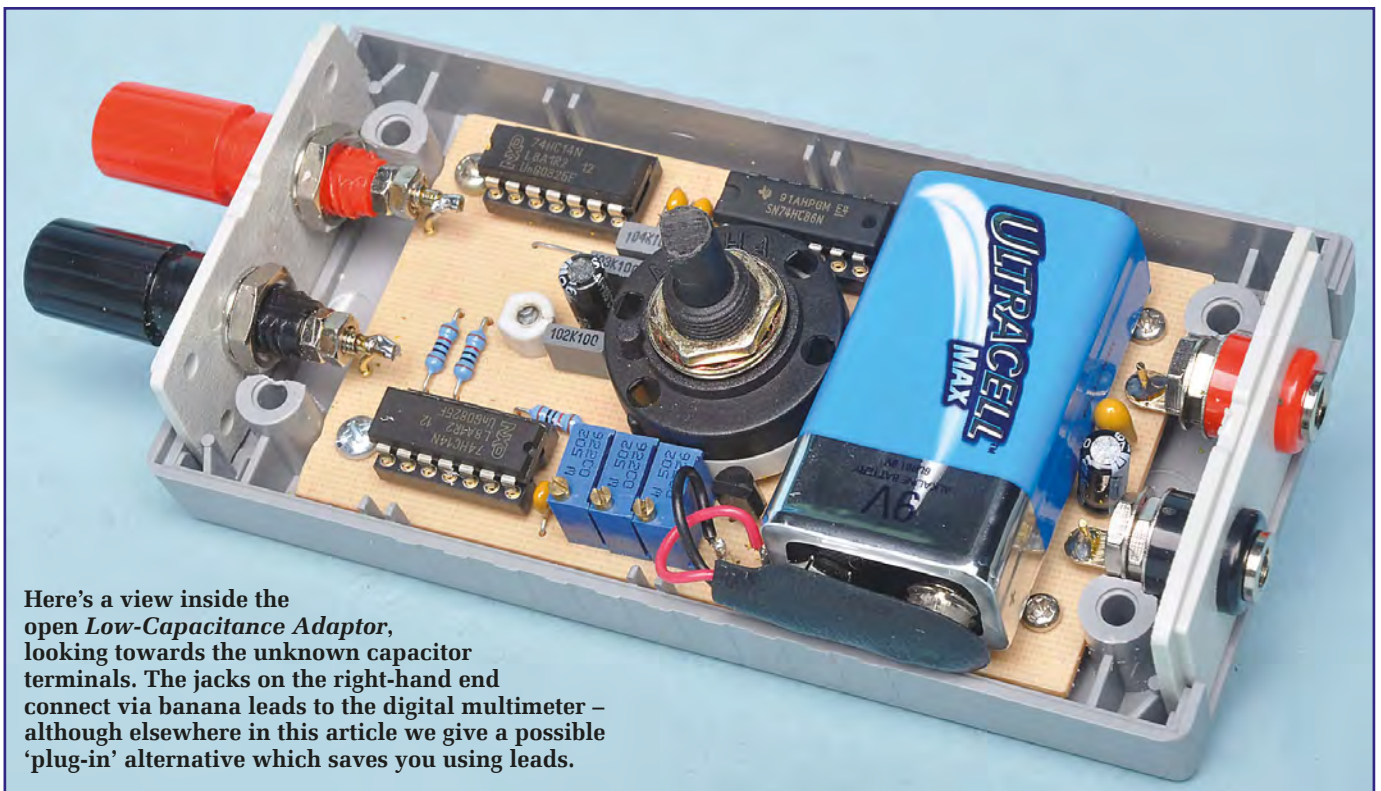

Here's a view inside the open Low-Capacitance Adaptor, looking towards the unknown capacitor terminals. The jacks on the right-hand end connect via banana leads to the digital multimeter – although elsewhere in this article we give a possible 'plug-in' alternative which saves you using leads.

# Constructional Project

width of the pulses will be directly proportional to the value of unknown capacitor  $C_x$ , because we deliberately limit the delay time to a relatively small proportion of the half-wave period of the square wave clock signal.

## Specifications

**Three measuring ranges –**

- Range A:  $0.1\text{pF} = 1\text{mV}$ , [gives a range from below  $0.3\text{pF}$  to above  $100\text{pF}$ ]
- Range B:  $1\text{pF} = 1\text{mV}$ , [gives a range from below  $1\text{pF}$  to above  $1000\text{pF}$  ( $1\text{nF}$ )]
- Range C:  $10\text{pF} = 1\text{mV}$ , [gives a range from below  $10\text{pF}$  to above  $10.0\text{nF}$ ]

**Accuracy:** Within approximately 2% of nominal full-scale reading, (assuming you can calibrate ranges using capacitors of known value).

**Power:** 9V alkaline or lithium battery.

**Current drain:** less than 5mA.

charging/discharging exponential curve.

## Circuit details

The full circuit of the *Low-Capacitance Adaptor* is shown in Fig.2. Schmitt inverter IC1a operates as the square-wave clock oscillator.

## Integration

The rest of the circuit is used as a simple integrator, to convert the positive-going pulses into a DC voltage. We feed the pulses through a non-inverting buffer, to ensure the pulses are all of constant peak-to-peak amplitude, and then through an integrator formed by series resistor  $R_4$  and shunt capacitor  $C_2$ .

The average DC voltage developed across  $C_2$  is directly proportional to the width of the pulses and it is this DC voltage that is measured by the DMM.

Although we are only using a simple RC combination to perform this integration, the relationship between the pulse width and the output DC voltage is reasonably linear because we have deliberately limited the integration to the initial 20% of the exponential RC charging and discharging curve.

That's why the nominal full-scale reading on each of our capacitance ranges is only 1.000V, even though all of the *Adaptor* circuitry operates from a 5V supply rail. In fact, you can use the *Low-Capacitance Adaptor* to measure capacitors with a value of more than the nominal full-scale value on each range, but the readings won't be as accurate as those for lower values because of the increasing curvature of the  $R_4C_2$

only difference from Fig.1 is that switches  $S_{1b}$  and  $S_{1c}$  allow three different  $C_1/VR_1$  combinations to be used, for oscillation at three different frequencies, to provide the three measurement ranges.

The remaining inverters in IC1 (a 74HC14 device) are used to form the non-inverting Schmitt buffer following the oscillator. IC1b squares up the signal initially, and then drives IC1c to IC1f in parallel to re-invert the signal and square it up even further.

The paralleled outputs of this clock buffer circuit drive the upper and lower arms of the time-delay comparator. Here the two  $10\text{k}\Omega$  1% resistors correspond to resistors  $R_2$  and  $R_3$  in Fig.1. However, the signals from the two delay circuits  $R_2/VC_1$  and  $R_3/C_x$  now pass through another pair of Schmitt inverters, IC2c and IC2a, which are part of a second 74HC14.

This has been done to square up both signals, to ensure that the output pulse widths from IC3a maintain their linear relationship to the value of the unknown capacitor being measured.

Although this squaring up is only necessary for the lower ( $C_x$ ) signal, because of its longer delay and hence greater 'rounding', we also pass the upper ( $VC_1$ ) signal through an identical inverter to ensure that it is inverted in the same

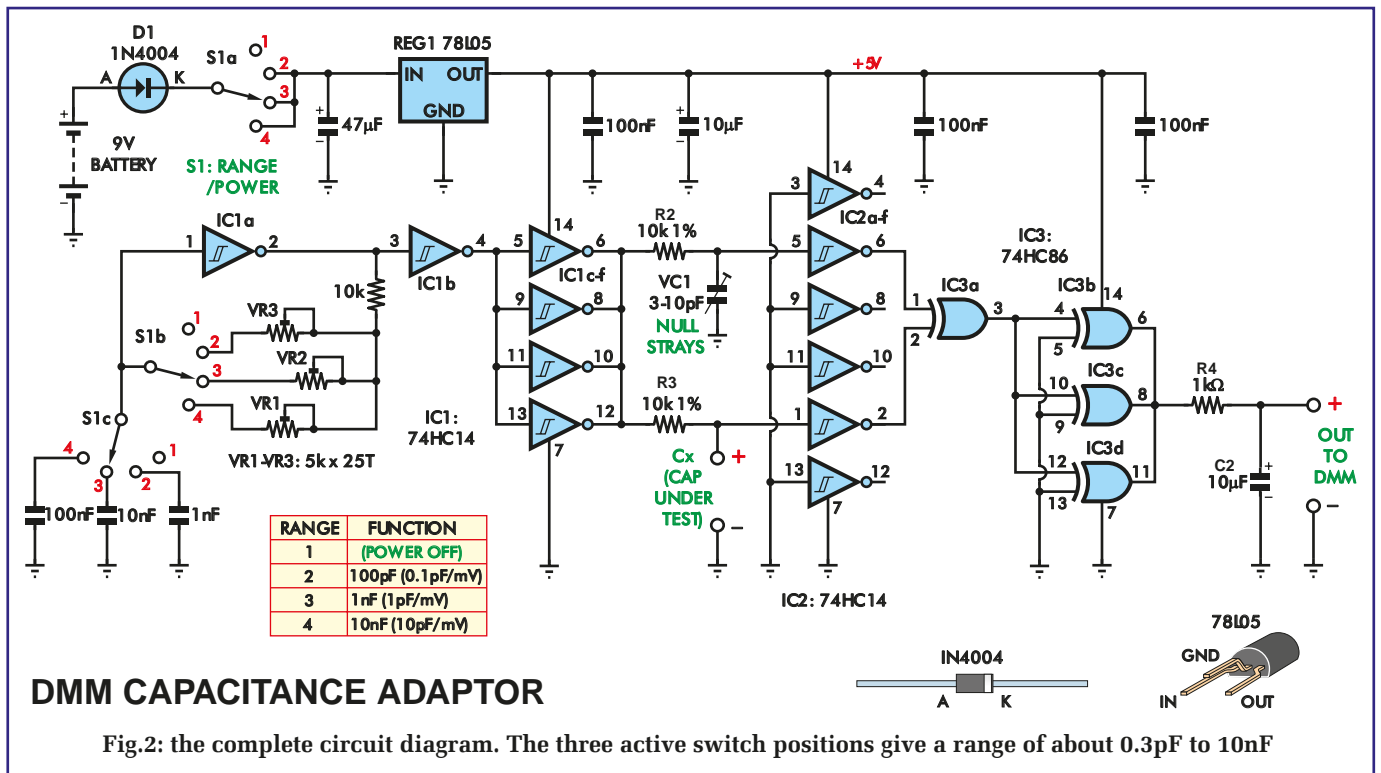

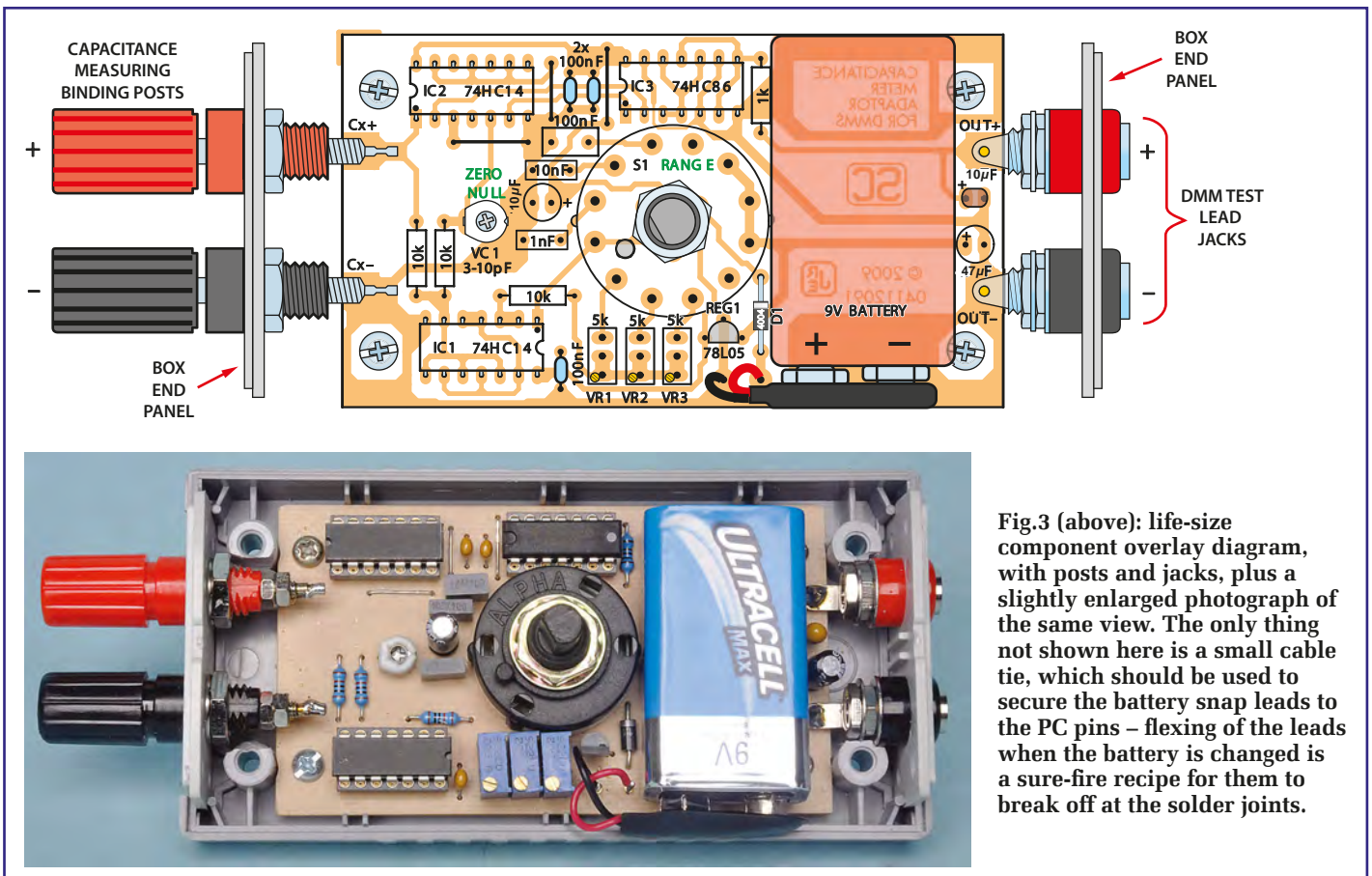

Fig.3 (above): life-size component overlay diagram, with posts and jacks, plus a slightly enlarged photograph of the same view. The only thing not shown here is a small cable tie, which should be used to secure the battery snap leads to the PC pins – flexing of the leads when the battery is changed is a sure-fire recipe for them to break off at the solder joints.

way as the lower signal. Thus, both signals have the same nominal phase and both signals have the same propagation delay, ie, via IC2a and IC2c.

IC3a is the XOR gate of the time-delay comparator, while the remaining three gates in IC3, a 74HC86 device, are used as a non-inverting buffer to drive the RC integrator.

Here the 1kΩ resistor corresponds to R4 in Fig.1, while the 10μF tantalum capacitor across the output jacks corresponds to C2. Gates IC3b to IC3d are used simply as non-inverting buffers.

### Power supply

Power is supplied by a 9V alkaline or lithium battery, with diode D1 used to prevent any possibility of reverse-polarity damage. Switch S1 acts as a combined power and range switch, with S1a used to switch off the *Adaptor* in the fourth (fully anticlockwise) position.

The circuit needs to run from a *regulated* DC supply rail, so that measurements don't vary as the battery voltage droops with age. Regulator REG1 is, therefore, used to provide a regulated +5V supply rail, provided the battery voltage remains above 7.5V.

Since the current drain of the circuit is below 5mA, we are able to use a 78L05 regulator (TO92 package) for REG1. The 47μF, 100nF and 10μF capacitors are used to filter any noise and switching transients which may appear on the +5V supply line.

### Construction

As you can see from the photos and the PC board overlay diagram of Fig.3, virtually all of the components used in

the *Adaptor* are mounted on a small PC board. This board is available from the *EPE PCB Service*, code 880 (90mm × 50.5mm), and fits snugly inside a plastic instrument box measuring 120mm × 60mm × 30mm.

The only components which are not mounted directly on the PC board are the binding posts and the output banana jack sockets (or banana jacks themselves) for connection to the DMM. The former mount on one end of the box, while the latter mount on the other end.

In each case, the posts and jacks connect to PC board pins. Note that the binding posts and jacks are both spaced apart by the standard 19mm (3/4-inch), to make them compatible with double-plug connectors.

Before you begin fitting the components to the PC board, it's a good idea to open up the box and check that the board will slip inside the lower half (the half with the countersunk holes for the final assembly screws). You may need to file off a small amount from all four sides of the board so that it will slip down to rest on the support pillars moulded in the inside of the box.

You may also need to file small shallow rounded recesses in the two ends to clear the larger pillars around the box assembly screw holes. It's much easier to do this before any components have been mounted on the board.

Begin the board assembly by fitting the three wire links, followed by the six PC pins: two each for the input terminals and output jack connections and two for the battery clip lead connections (just below the positions for diode D1 and voltage regulator REG1, at lower centre).

Next, fit the three 14-pin IC sockets, noting that IC1's socket has its notched end to the right, while those for IC2

## Connecting to your DMM: another approach

While this project was being prepared for publication, it occurred to us that there was another, perhaps even more logical way to connect the Adaptor to a DMM – particularly if you would like a more ‘hands free’ operation.

This takes into account the fact that the overwhelming majority of DMMs which use 4mm sockets (and we would have to say ALL pro-quality units) have a standard 19mm spacing between those sockets.

Therefore, we reasoned, it would be quite sensible to replace the banana jack sockets on the ‘output’ end with banana jacks – thus allowing the unit to be plugged directly into the DMM.

At the expense of some flexibility, this would mean that there would be no need to make up a set of Adaptor-to-DMM leads. Try as we might, we could not easily find a set of these already made up. You can get banana to probe, banana to alligator clip, banana to multiple adaptors, even banana to blade fuse fittings (for automotive use) but banana to banana? Nada. Zilch. Nyet!

So, the only alternative would have been to buy some figure-8 red and black lead (believe it or not, also getting hard to find in lightweight, flexible type!) and two pairs of red and black banana plugs to connect to this lead.

The alternative approach, as shown above and below, is to fit a pair of red and black banana plugs through the end of the case. We used some scrap PC board material, cut and shaped the same as the end panels, with a strip of copper removed down the middle. Drilled appropriately, this gave us a handy ‘platform’ to which we soldered the two banana plugs (inside) without their plastic shrouds. The plugs were then connected back to their respective PC pins using short lengths of tinned copper wire (eg, resistor/capacitor lead offcuts).

Presto – a plug-in adaptor. And if you want to use it off the DMM? Simply use a banana-to-alligator clip lead set.



and IC3 are to the left – see Fig.3. Next, fit the four resistors followed by the three 5kΩ 25-turn trimpots. Make sure you install all three trimpots with their adjustment screws at lower left, as shown on Fig.3.

Now add the fixed capacitors, taking care to place the polarised 47µF and 10µF units with the correct orientation. Then fit the mini trimcap (VC1) in position, with its ‘flat’ end to the left, as shown.

Rotary switch S1 is fitted next, after cutting its spindle to about 10mm long and smoothing off any cutting burrs with a small file. The switch mounts on the board with its moulded locating spigot at approximately the 7:30 position, viewed from above, and with the board oriented as shown in the overlay diagram (ie, with IC1 at lower left).

### Adjusting the switch travel

S1 is a ‘universal’ type of rotary switch offering a number of switch positions, so after it is installed, it needs to be set for the four positions we require. That’s done by first removing the nut and lockwasher from its threaded bush and then lifting up the stopwasher. You then turn the spindle anticlockwise by hand as far as it will go and refit the stopwasher with its stop pin passing down through the hole between the digits ‘4’ and ‘5’ moulded into the switch body.

Finally, replace the lockwasher and nut, threading the latter down until it’s holding down both washers firmly. You should now find that if you try turning the spindle by hand, it will have a total of four positions – no more and no less.

Don’t be caught by the old trap of thinking you only have three positions because it only clicks three times. Remember it clicks to three *more* positions from its end position.

Now fit regulator REG1 and diode D1 to the board, taking care to ensure correct polarity. Once they’re in, plug IC1 to IC3 into their respective sockets. The board assembly will now be complete and can be put aside while you drill the various holes in the top, bottom and end panels of the plastic case.

### Preparing the box

Two holes need to be drilled in each of the end panels and five holes drilled in the top of the box (see Fig.4). You will also need to cut away a small amount from the sides of the internal mounting pillars on both the top and bottom of the box, to provide clearance for the rear ends of the capacitance measuring binding posts and DMM test lead jacks. This can be done with a small milling cutter in a high-speed rotary tool, or it can be done manually using a sharp hobby knife.

Both pairs of holes in the end panels need to have a diameter to suit the binding posts and banana jacks you are using. They are located on the centre line of their panel, but 9.5mm away from the centre-line in each case – so the binding posts and jacks both end up spaced apart by the standard figure of 19mm (3/4-inch).

The five holes in the top of the box can be located quite accurately using a photocopy of the front panel artwork as a template (this artwork includes a dashed outer rectangle to show the outline of the box itself – see Fig.4). The central hole for the power/range rotary switch is 10mm in diameter, while the other four holes are 3.5mm in diameter. These latter holes allow adjustment of the zero null trimcap and calibration trimpots when the unit is fully assembled.

The exact location and amount of material which must be removed to clear the binding posts and banana jacks will

depend very much on the actual posts and jacks that you use. You can see from the internal photos where material needed to be cut away for the posts and jacks used in the prototype.

By the way, the binding posts used in the prototype were the PT-0453 and PT-0454 from Jaycar, while the banana jacks were the PS-0406 and PS-0408 (also from Jaycar). Other posts and jacks may need the removal of either less or more material, but you should be able to fit in most types that are currently available.

The last step in preparing the box is to make another photocopy or printout of the front panel artwork (Fig.4) on either an adhesive-backed label sheet with a piece of clear self-adhesive film over the top. Alternatively, for really long life and best protection, plain paper laminated in a plastic sleeve can be used. The label is then cut out and attached to the top half of the box, making sure the holes line up.

## Final assembly

The first step in the final assembly is to mount the binding posts and banana jacks on their respective end panels, tightening their mounting nuts to make sure they won't be able to rotate and work loose. Note that in the case of the banana jacks, you also need to mount them with their solder tags orientated vertically downwards so that after the nuts are tightened, the tags can be bent up by 90°. This is to allow the holes in the tags to be later slipped down over the terminal pins on the PC board.

Next, lower the PC board assembly into the lower half of the box and secure it in place using four small self-tapping screws. That done, lower the end panel with the output jacks down into the slot at that end of the case, with the tags on the rear of the jacks passing down over the terminal solder pins of the PC board. When the panel is down as far as it will go, solder the jack tags to the terminal pins to make the connections permanent.

The other end panel (with the binding posts) is then fitted in much the same way, except that in this case there are no solder tags at the rear of the posts. Instead, you may need to bend over the terminal pins on the PC board so that they clear the rear spigots of the binding posts and are alongside them, ready for soldering. When this panel is down as far as it will go, the binding posts can be soldered to the board pins.

The next step is to cut the battery snap lead wires fairly short – about 20mm from the snap sleeve – then strip off about 5mm of insulation from the end of each wire. These wires can then be soldered to their respective PC board pins, just below REG1 and D1 in Fig.3.

After checking that everything looks correct, connect the battery to the battery snap and your *Low-Capacitance Adaptor* is just about ready for its initial set-up. All that remains is to fit the operating knob to the spindle of switch S1 temporarily, to make things easier during the set-up operation.

## Initial set-up

The first step here is to select the DMM that you are going to use and make up a lead to connect the output of the *Adaptor* to the DMM's DC voltage inputs. In most cases, the lead will need standard banana plugs at each end.

## Parts List – DMM Low-Capacitance Adaptor

- 1 PCB, code 880, available from the *EPE PCB Service*, size 90mm × 50.5mm
- 1 utility box, 120mm × 60mm × 30mm
- 1 3-pole, 4-position rotary switch (S1)
- 1 Instrument knob, 16mm diameter
- 1 binding post, red
- 1 binding post, black
- 1 banana jack socket, red
- 1 banana jack socket, black
- 1 9V alkaline or lithium battery
- 1 9V battery snap with leads
- 3 14-pin DIL IC sockets
- 6 1mm diameter PC board terminal pins
- 1 small cable tie
- 4 small self-tapping screws, max 5mm long

### Semiconductors

- 2 74HC14 hex Schmitt inverter (IC1, IC2)
- 1 74HC86 quad XOR gate (IC3)
- 1 78L05 low power +5V regulator (REG1)
- 1 1N4004 1A rect. diode (D1)

### Capacitors

- 1 47µF 16V PC electrolytic
- 1 10µF 16V PC electrolytic
- 1 10µF 25V TAG tantalum
- 3 100nF multilayer monolithic ceramic
- 1 100nF MKT metallised polyester
- 1 10nF MKT metallised polyester
- 1 1nF MKT metallised polyester
- 1 3pF to 10pF mini trimcap (VC1)
- 3 known value reference capacitors (see text)

### Resistors (0.25W, 1%)

- 3 10kΩ      1 1kΩ
- 3 5kΩ 25-turn cermet trim pots (VR1, VR2, VR3)

That done, connect the *Adaptor* and DMM together using this lead and turn on the DMM, switching it to a fairly low DC voltage range, eg, the range with a full-scale reading of 1.999V or 1999mV.

Turn S1 to the first position ('Range A'). You should find that the DMM will give a relatively low reading – less than 10mV to 15mV. This reading is due to the fact that the stray capacitance of the *Adaptor's* input binding posts has not yet been nulled by trimpot VC1. So, the next step is to use a small plastic or ceramic alignment tool to adjust VC1 very carefully, to get a minimum or 'null' in the DMM's reading. You should be able to bring the reading down to below 1mV.

If you are able to achieve this null, your *Adaptor* is very likely to be working correctly and the next step is to calibrate each of the three ranges.

For the three calibration steps, you're going to need three polystyrene, polyester or silvered mica capacitors whose values are accurately known, because the accuracy of your *Adaptor* will depend on them. The three capacitors should

# Constructional Project

have values close to 100pF, 1nF and 10nF respectively, because these are the nominal full-scale readings of the *Adaptor's* three ranges.

They needn't have these exact values, but ideally you should know their *actual* values, as measured using a calibrated digital capacitance meter or LCR meter.

Once you have these three known-value or reference capacitors, the calibration of your *Adaptor* is relatively straightforward.

## Calibration

With the *Adaptor* still switched on and set to Range A, first connect the 100pF capacitor to the *Adaptor's* binding posts using the shortest possible lead lengths. Then adjust trimpot VR3 until the DMM reading in tens of millivolts corresponds to the capacitor's actual value in tenths of a picofarad (pF). For example, if your capacitor has a known value of 101.5pF, adjust VR3 until the DMM reading becomes 1015mV or 1.015V.

Once this has been done, repeat this process on Range B, this time using the 1nF reference capacitor and trimpot VR2 to make the adjustment. VR2 should be adjusted until the DMM reading in millivolts corresponds to the capacitor's actual value in picofarads. For example, if the capacitor has a known value of 1.013nF or 1013pF, adjust VR2 until the DMM reading is 1.013V.

Finally, repeat the process again for Range C, this time using the 10nF reference capacitor and trimpot VR1 to make the adjustment. The correct setting for this range is where the DMM reading in millivolts corresponds to the capacitor's actual value in tens of picofarads. For example, if the capacitor has a value of 9.998nF, the DMM reading should be 999.8mV or 0.9998V.

That's all there is to it. Once you have calibrated each range in this way, you can switch off the *Adaptor* using S1, remove the knob from its spindle and then fit the top of the case in place (make sure you don't catch the battery snap wires under the side panel). Once it's in place, fit the four countersunk-head screws to secure the two case halves together. After this, all that should remain is to refit the knob to the spindle of S1.

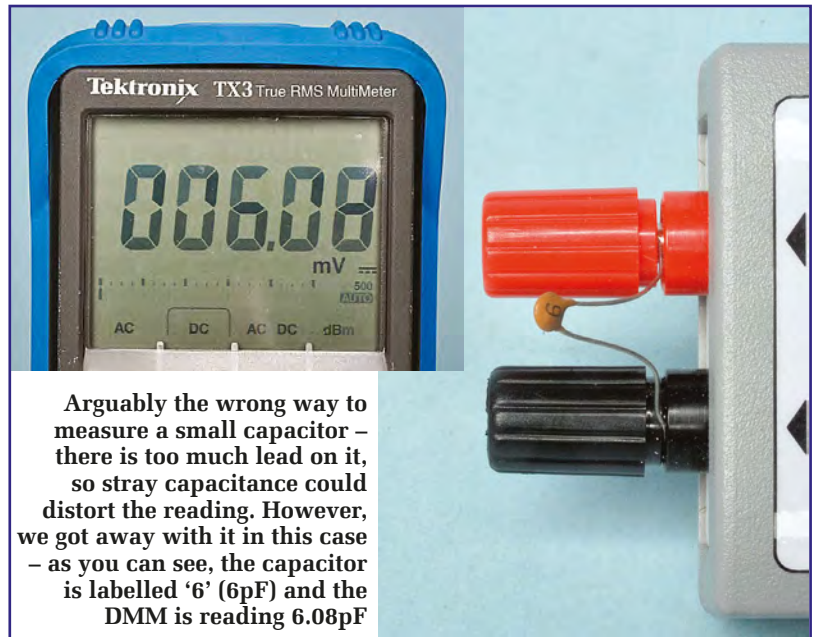

Just before you declare your *Adaptor* ready for use, it's a good idea to check the setting of null trimcap VC1. That's because the stray capacitance associated with the input binding posts does tend to change very slightly when the box is fully assembled.

To do this, you need to switch the *Adaptor* on again, in Range A with nothing connected to the binding posts. You can then readjust VC1 using the plastic alignment tool (passing down through the ZERO NULL hole in the front panel) to see if you can improve the null reading on the DMM.

## Using the Adaptor

Putting the *Adaptor* to use is also quite straightforward. Basically, it's just a matter of hooking it up to your DMM, setting the DMM to the 0V to 2V DC range and then turning on the *Adaptor*. You then select the appropriate range on the *Adaptor*, connect the capacitor to be measured to its binding posts and read the resulting voltage on the DMM. This reading is then converted to obtain the capacitance, using the legends printed on the *Adaptor's* front panel.

There are a few things to bear in mind if you want to achieve the best measurement accuracy. For example, when you are measuring really low-value capacitors in particular (ie, below 100pF), try to connect them to the binding posts with the *shortest* possible lead length. This is because any excess lead length will add extra stray capacitance, as well as a tiny amount of lead inductance. Both of these will degrade reading accuracy, because measurements on Range A are done at a frequency of about 110kHz.

## Test leads

If you can't connect a capacitor directly to the binding posts with minimum lead lengths, an alternative is to

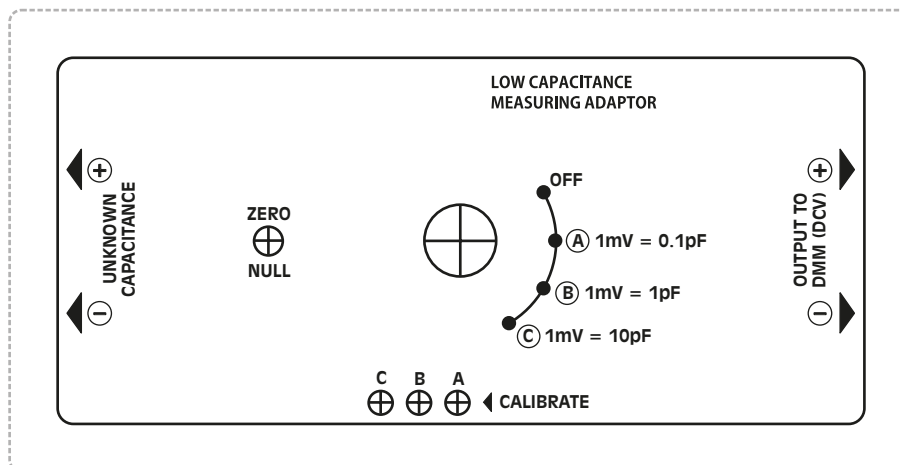

Fig.4: this same-size front panel artwork can also be used as a template for drilling the five holes required

make up a pair of short but stiff (ie, *heavy gauge*) test leads, each with a banana plug at one end and a small crocodile clip at the other. The leads should then be plugged into the binding posts and zero null trimcap VC1 adjusted with an alignment tool (on Range A) to null out the additional stray capacitance.

You can then connect the capacitor to the test lead clips and measure its capacitance as before.

You can follow a similar procedure to use the *Adaptor* as a handheld probe to measure stray capacitance, as opposed to measuring the value of discrete capacitors. It's a good idea to make a small probe tip out of a 30mm length of 4mm-diameter brass rod (eg, brazing rod), with a fairly sharp point ground or filed at one end and the other end slit down the centre with a fine hacksaw for about 8mm to 10mm. The slit end can then be expanded slightly with a small screwdriver, so that it will just slip inside the *Adaptor's* positive (red) binding post and stay in position.

You also need to make up a short but stiff test lead for the earth return, with a spade lug at one end (to be clamped under the negative binding post) and a small crocodile clip on the other end to connect to the reference metalwork for the stray capacitance to be measured. The probe tip and earth return lead made up for the prototype are visible in the photos to the right.

Here again, you need to null out the additional stray capacitance associated with the added probe tip and earth return lead, before making the actual measurement. As before, this is easy to do: simply fit the probe tip and earth return lead, set the *Adaptor* to Range A and adjust VC1 with an alignment tool for the deepest null in the DMM reading. Then you can proceed to make your measurements of stray capacitance.

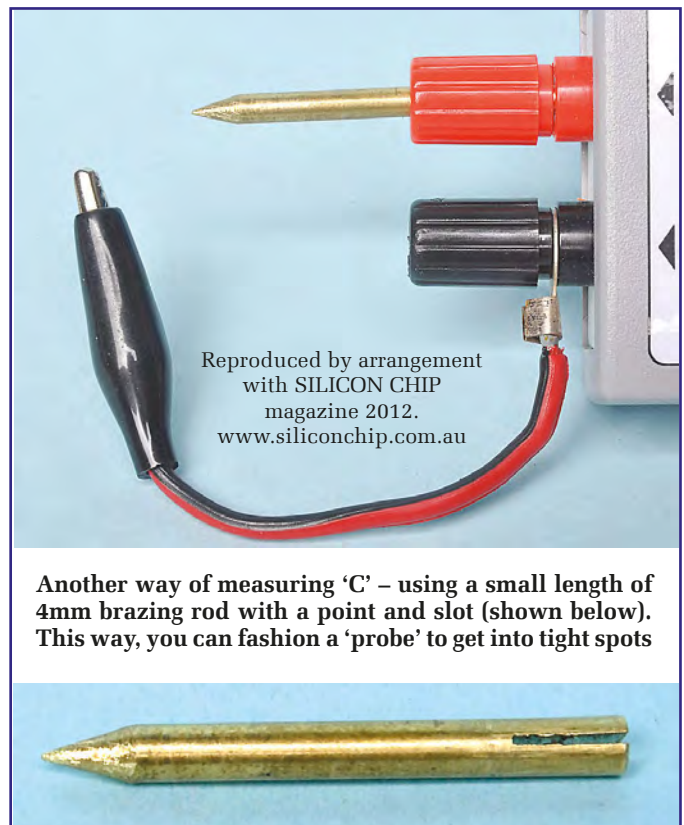

Another way of measuring 'C' – using a small length of 4mm brazing rod with a point and slot (shown below). This way, you can fashion a 'probe' to get into tight spots

Get the idea? It's quite in order to use test leads and/or measuring jig attachments to connect whatever capacitance you want to measure to the *Adaptor's* binding posts, providing you null out the added stray capacitance using VC1 (on Range A) before making the actual measurements. **EPE**

**matrix**

# MIAC™

## MIAC e-system design suite

**SIMPLE**

Drag and drop software means that no programming experience is needed

**RUGGED**

12V or 24V control, switch up to 240V

**SCALABLE**

Up to 100 modules in a system

**FLEXIBLE**

Compatible with comms. standards, sensors and software

[www.matrixmultimedia.com](http://www.matrixmultimedia.com)

## UK readers you can SAVE 94p on every issue of EPE

How would you like to pay £3.46 instead of £4.40 for your copy of EPE?



Well you can – just take out a one year subscription and save 94p an issue, or £11.28 over the year. You can even save £1.15 an issue if you subscribe for two years – a total saving of £27.60.

Overseas rates also represent exceptional value.

**You also:**

- Avoid any cover price increase for the duration of your subscription
- Get your magazine delivered to your door each month
- Ensure your copy, even if the newsagents sell out

Order by phone or fax with a credit card or by post with a cheque or postal order, or buy online from [www.epemag.com](http://www.epemag.com) (go to the 'UK Store').

## EPE EVERYDAY PRACTICAL ELECTRONICS

### SUBSCRIPTION PRICES

Subscriptions for delivery direct to any address in the UK: 6 months £21.95, 12 months £41.50, two years £78.00; Overseas: 6 months £25.00 standard air service or £35.00 express airmail, 12 months £48.00 standard air service or £68.00 express airmail, 24 months £91.00 standard air service or £131.00 express airmail.

Cheques or bank drafts (in £ sterling only) payable to *Everyday Practical Electronics* and sent to EPE Subs. Dept., Wimborne Publishing Ltd., 113 Lynwood Drive, Merley, Wimborne, Dorset, BH21 1UU. Tel: 01202 880299. Fax: 01202 843233. Email: [subs@wimborne.co.uk](mailto:subs@wimborne.co.uk). Also via the Web at: [www.epemag.com](http://www.epemag.com) (go to the 'UK Store').

Subscriptions start with the next available issue. We accept MasterCard, Maestro or Visa. (For past issues see the Back Issues page.)

### ONLINE SUBSCRIPTIONS

Online subscriptions, for downloading the magazine via the Internet, \$19.99US (approx. £13.00) for one year available from [www.epemag.com](http://www.epemag.com).

### SUBSCRIPTION ORDER FORM

- 6 Months: UK £21.95, Overseas £25.00 (standard air service), £35.00 (express airmail)
- 1 Year: UK £41.50, Overseas £48.00 (standard air service) £68.00 (express airmail)
- 2 Years: UK £78.00, Overseas £91.00 (standard air service) £131.00 (express airmail)

To: *Everyday Practical Electronics*, Wimborne Publishing Ltd., 113 Lynwood Drive, Merley, Wimborne, Dorset BH21 1UU  
Tel: 01202 880299 Fax: 01202 843233  
E-mail: [subs@epemag.wimborne.co.uk](mailto:subs@epemag.wimborne.co.uk)

I enclose payment of £ ..... (cheque/PO in £ sterling only), payable to *Everyday Practical Electronics*

Please charge my Visa/Mastercard/Maestro

My card number is: .....  
Please print clearly, and check that you have the number correct

Signature .....

Card Security Code ..... Valid From Date.....  
(The last 3 digits on or just under the signature strip)

Card Ex. Date .....Maestro Issue No. ....

Name .....

Address .....

Post code ..... Tel. ....

Subscriptions can only start with the next available issue.





# Take Time and Cost out of Embedded Design

## With Microchip Development Tools



The banner features a central graphic with the text "MPLAB X" in large, red, dot-matrix letters, with "Integrated Development Environment" written below it. Surrounding this text are images of various Microchip development tools: an MPLAB ICD 3 in-circuit debugger, an MPLAB REAL ICE in-circuit emulator, and a PICkit 3 starter kit. The background is a collage of technical diagrams and circuit boards.

**Cross-Platform • Universal • Open-Source**

With over 1.15 million development systems already shipped, Microchip Technology has a reputation for providing a comprehensive range of world-class, low-cost, easy-to-use application development tools. Combining Microchip's powerful free MPLAB® IDE with application- and product-specific starter kits cuts the cost and complexity of your embedded designs.

MPLAB X IDE is the new single, universal graphical user interface for Microchip and third party software and hardware development tools. It is the industry's only IDE to support an entire portfolio of 800+ 8-bit, 16-bit and 32-bit PIC® MCUs, dsPIC® DSCs and memory devices. It includes a feature-rich editor, source-level debugger, project manager, software simulator, and supports Microchip's popular hardware tools, such as the MPLAB ICD 3 in-circuit debugger, PICkit™ 3 starter kit, and MPLAB REAL ICE™ in-circuit emulator.

Based on the open-source NetBeans platform, MPLAB X runs on Windows® OS, MAC® OS and Linux, supports many third-party tools, and is compatible with many NetBeans plug-ins.

Add starter kits, reference designs and webinars for specific PIC MCU and dsPIC DSC families and you have all the tools you need to fast-track your embedded design. The low-cost starter kits help you to use application-optimized PIC MCU and dsPIC DSC families in wireless and wired networks, security, motor control, automotive and low-power designs, as well as in graphics and general-purpose applications.

**Start now! Download the MPLAB IDE Quick Start manual at:**  
[www.microchip.com/tools](http://www.microchip.com/tools)

### THE MPLAB® IDE TOOLKIT FOR FAST AND EFFECTIVE EMBEDDED DESIGN:



MPLAB® ICD 3 - DV164035



MPLAB® REAL ICE™ - DV244005



PICkit™ 3 Debug Express  
- DV164131

**microchip**  
**DIRECT**  
[www.microchipdirect.com](http://www.microchipdirect.com)

 **MICROCHIP**

**Microcontrollers • Digital Signal Controllers • Analog • Memory • Wireless**

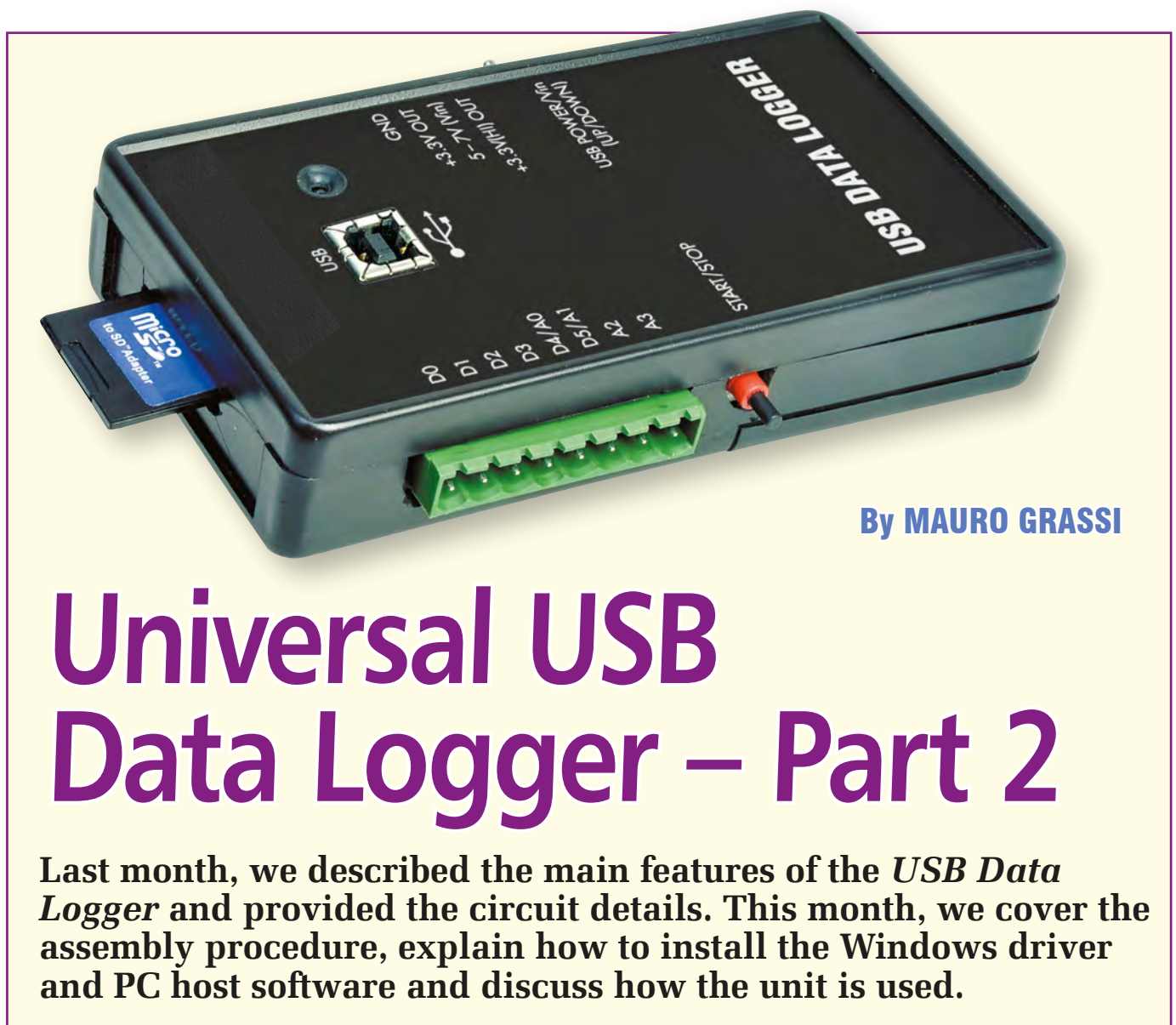

By MAURO GRASSI

# Universal USB Data Logger – Part 2

Last month, we described the main features of the *USB Data Logger* and provided the circuit details. This month, we cover the assembly procedure, explain how to install the Windows driver and PC host software and discuss how the unit is used.

AS MENTIONED last month, a major feature of the *USB Data Logger* is its custom scripting language. This makes it very versatile and allows it to be interfaced to many different sensor types. It can be interfaced to most digital sensors, practically all I<sup>2</sup>C and 1-wire sensors, and almost any analogue sensor, frequency input or counter.

Custom scripting also makes it highly configurable. If you have a logging application in mind, this unit will almost certainly be suitable.

The accompanying PC software is used to compile the custom 'scripts'. These provide the instructions for reading the various sensors and for processing the data. So, this unit can not only log data, but can also analyse that data!

Towards the end of this article, we run through a number of scenarios and give some example custom scripts. These are a good starting point for learning to write scripts for your own logging applications.

### What it can do

Before moving on to the construction, let's run through a few things the *USB Data Logger* can do.

First, if you have a weather station, you can log a whole day's worth of temperatures and then compute the average. You could also extract the daily maximum and minimum temperatures and log them as well.

Second, if you have a number of digital sensors connected to the I<sup>2</sup>C bus, you can send commands to read from them, log their values or send

commands to power them down during extended periods when no logging needs to occur. Note that the *USB Data Logger* itself will automatically switch into standby mode during extended periods of inactivity to save power.

You can also read from a sensor and execute code depending on the reading reported by the sensor. For example, if you have a temperature sensor, you can monitor its value and turn an external relay on or off (eg, to control an air-conditioner) if the value is outside a specific range.

These are just some examples of what is possible.

### Writing a program

If you've ever programmed before, it should be very easy to understand and write programs for the *Logger* (the

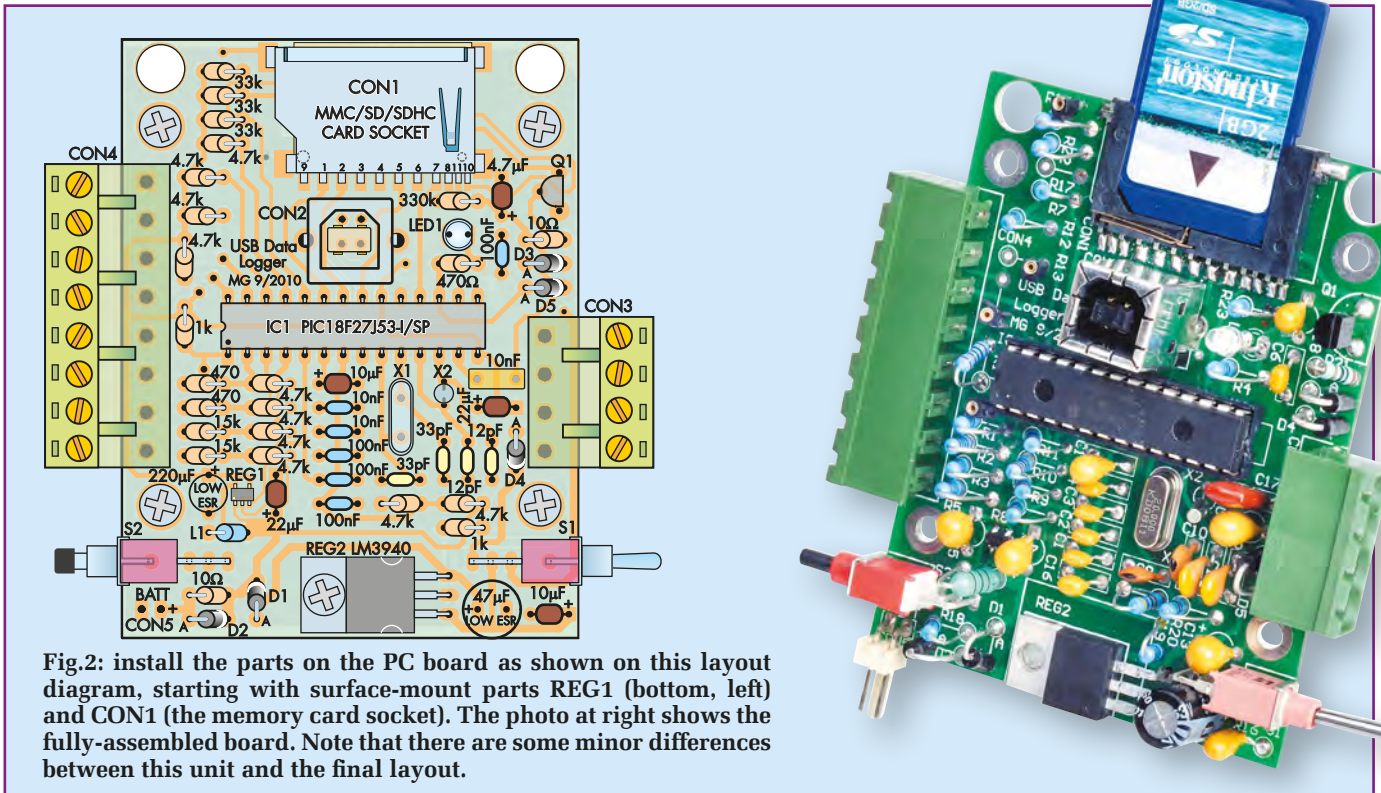

**Fig.2:** install the parts on the PC board as shown on this layout diagram, starting with surface-mount parts REG1 (bottom, left) and CON1 (the memory card socket). The photo at right shows the fully-assembled board. Note that there are some minor differences between this unit and the final layout.

scripting language's syntax is simple and loosely based on C). If not, we give a very quick introduction at the end of this article, with a number of examples showing code that can be used.

**It shouldn't take too long to learn, and a full description of the language can be downloaded as a PDF file from the January 2013 section of the EPE website: [www.epemag.com](http://www.epemag.com).**

### Board assembly

The *Universal USB Data Logger* is built on a double-sided PC board measuring 60mm × 78 mm. This PC board is available from the *EPE PCB Service*, code 878. The board is housed in a plastic instrument case measuring 68mm × 130mm × 25mm (W × D × H).

The printed circuit board component layout is shown in Fig.2, alongside a photo of the completed *Logger* board. It should take no more than a couple of hours to assemble, but before starting, check it carefully for hairline cracks in the copper pattern and for shorts between tracks and pads.

Once you are satisfied that everything is OK, start the assembly by soldering in the SMT (surface-mount technology) boost regulator (REG1). This is a TPS61097-33DBVT device in an SOT23 5-pin package and is mounted on top of the board, towards the bottom left corner, between two capacitors.

You will need a fine-tipped soldering iron and a steady hand to solder it in. A magnifying lamp will also be useful, if you have one.

The best way to install REG1 is to first position it over its pads (it can only go one way) and then hold it in position using some sticky tape, leaving pin 5 uncovered (see Fig.1 in Part 1). That done, heat the pin and apply the solder quickly, taking care not to apply the heat for more than a few seconds. The solder should melt easily and secure the pin and pad.

Let it cool, then solder pin 3, which is diagonally opposite. Once that is done, you can remove the sticky tape and solder the remaining three pins. If any solder bridges form, use solder-wick (or desoldering braid) to remove them.

The memory card socket is next on the list, and this is also soldered to the top of the board. It has two small plastic locating posts that fit into matching holes in the PC board. These correctly place it in position over its pads.

Solder the two holding pads on its sides first to secure it in place. Once that is done, solder the rest of the pins, but be careful not to apply heat to the plastic body, as it will melt. As before, use solder-wick if you accidentally create solder bridges between adjacent pins.

Now for the resistors and inductor L1 (47µH). You should check each one using a DMM before installing it on the board. Note that, due to space restrictions, L1 and the resistors are all mounted vertically (see photos and Fig.2).

The five Schottky diodes can go in next. Unlike the resistors, these need to be oriented correctly. Their cathodes are indicated by a grey stripe at one end, while each anode connection is indicated with an 'A' in Fig.2.

The TO-220 regulator (REG2) mounts horizontally on the PC board. To do this, first bend its leads down through 90° about 4mm from its body, then mount it in position. Note that a screw is not normally used to secure it, as it is not strictly required and would interfere with the case. However, if you are concerned about mechanical stress, you can secure it using an M3 screw and nut and drill a hole through the bottom of the case to provide clearance.

Once the regulator is in position, the three leads can then be soldered and trimmed.

The 28-pin IC socket for the microcontroller (IC1) can now be installed. If you don't have a 28-pin 0.3-inch socket, you can use two 14-pin sockets arranged end to end. Be sure to install the socket (or sockets) with the notch facing in the correct direction (ie,

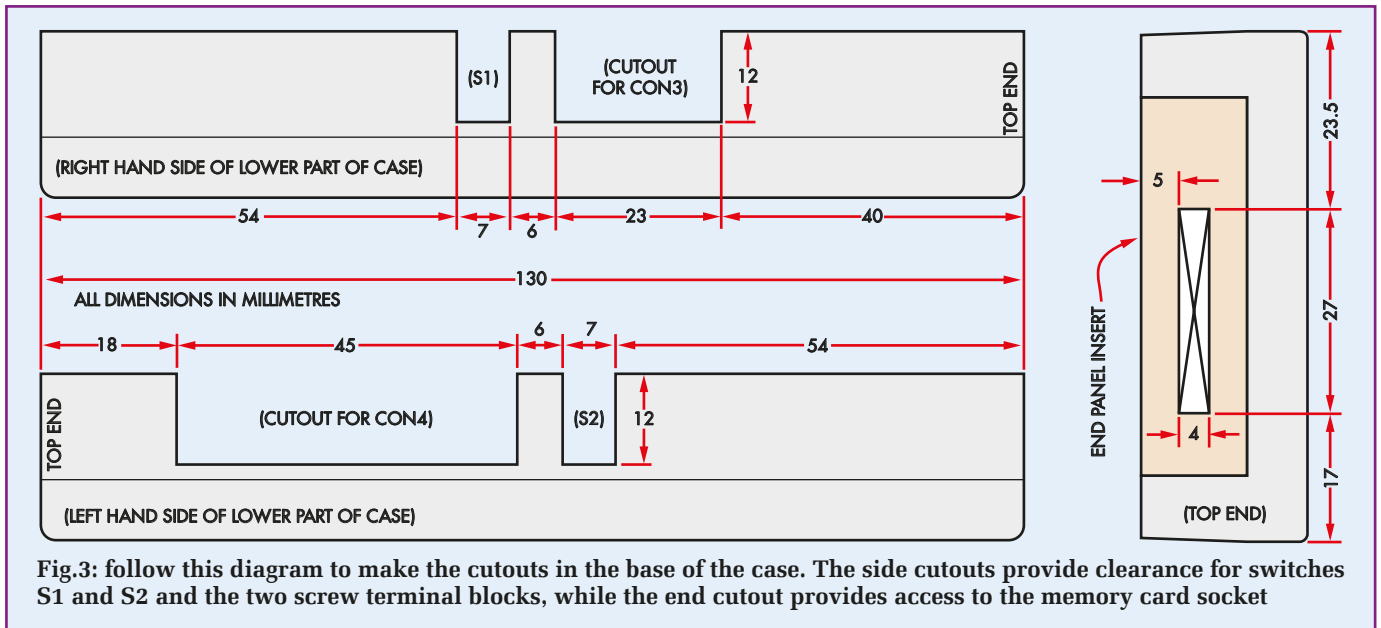

towards CON4) to avoid confusion when installing IC1 later on.

Follow on by installing the capacitors. There are four types on the board:

monolithic, ceramic, tantalum and electrolytic. Note that the tantalum (brown on Fig.2) and electrolytic capacitors are polarised and must be installed with the correct orientation.

Crystals X1 and X2 should be installed next. These can go in either way around, but note that X1 is the 20MHz crystal, while X2 is the smaller 32.768kHz crystal. Note also that X2's leads are delicate, so take extra care when installing it. Push it down as far as it will comfortably go without stressing the leads before soldering.

The 2N7000 FET (Q1) is next, followed by switches S1 and S2. S1 is a mini toggle switch (S1), while S2 is a momentary pushbutton switch. Make sure they sit flush against the PC board before soldering their leads.

The 8-way and 4-way horizontal terminal block headers must also be mounted flush against the PC board. Solder these in place now, then install the vertical-mounting USB Type-B socket. This socket has two mounting tabs on either side that secure it in place – solder these first, then solder the four pins towards the centre.

The adjacent 3mm blue LED (LED1) must be installed with its body 11mm above the surface of the PC board. A 10mm cardboard spacer between the leads can be used to set the height. Make sure that the LED is correctly oriented (ie, anode to the left).

Finally, connect the 2-way AAA cell holder to the supply terminals (BATT) at bottom left. The red lead

goes to the '+' terminal, while the black lead goes to the remaining terminal.

That completes the assembly of the PC board, apart from installing IC1. This is left out of its socket until after some initial power supply checks.

### First switch-on

You should use two AAA cells to initially power the *Logger* board and check the supply rails. We recommend that you use two NiMH, 900mAh to 950mAh batteries, although cells of greater or lesser capacity can also be used. Note, however, that you may have to change the 10Ω charging resistor in parallel with diode D2, depending on your battery type.

The method used for calculating this resistor value was given in Part 1 last month (final page). Make sure that the two AAA cells are charged before attempting to use them.

Assuming they are charged, insert them into the batteryholder and check the voltage between pin 2 (V<sub>DD</sub>) and pin 1 (GND) of CON3. This should be close to 3.3V. If this is incorrect, disconnect the batteries *immediately* and recheck your work around REG1. If there's no voltage at REG1's output, check the orientation of diode D2.

If you do get the correct 3.3V, remove the cells and insert IC1 into its 28-pin socket. **Make sure it is correctly oriented, with its notched end matching the component overlay.**

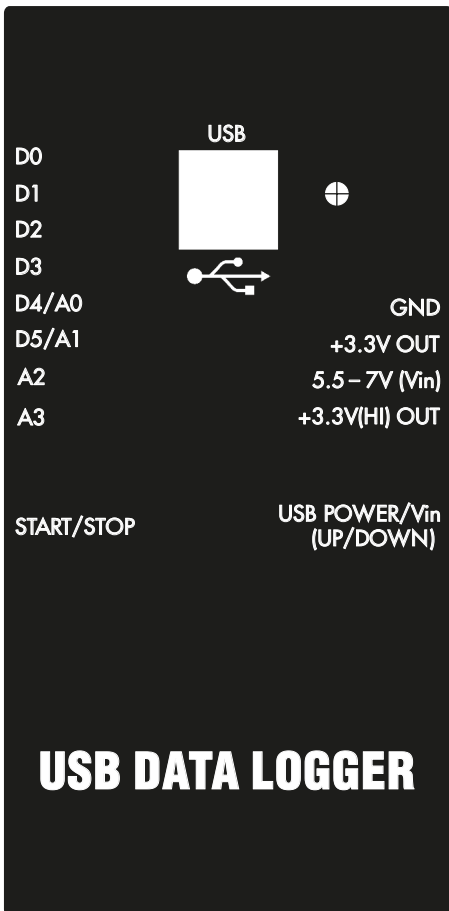

**Fig.4: this front-panel artwork can be used as a template for cutting out the access hole for the USB socket and drilling a hole for the 3mm blue LED**

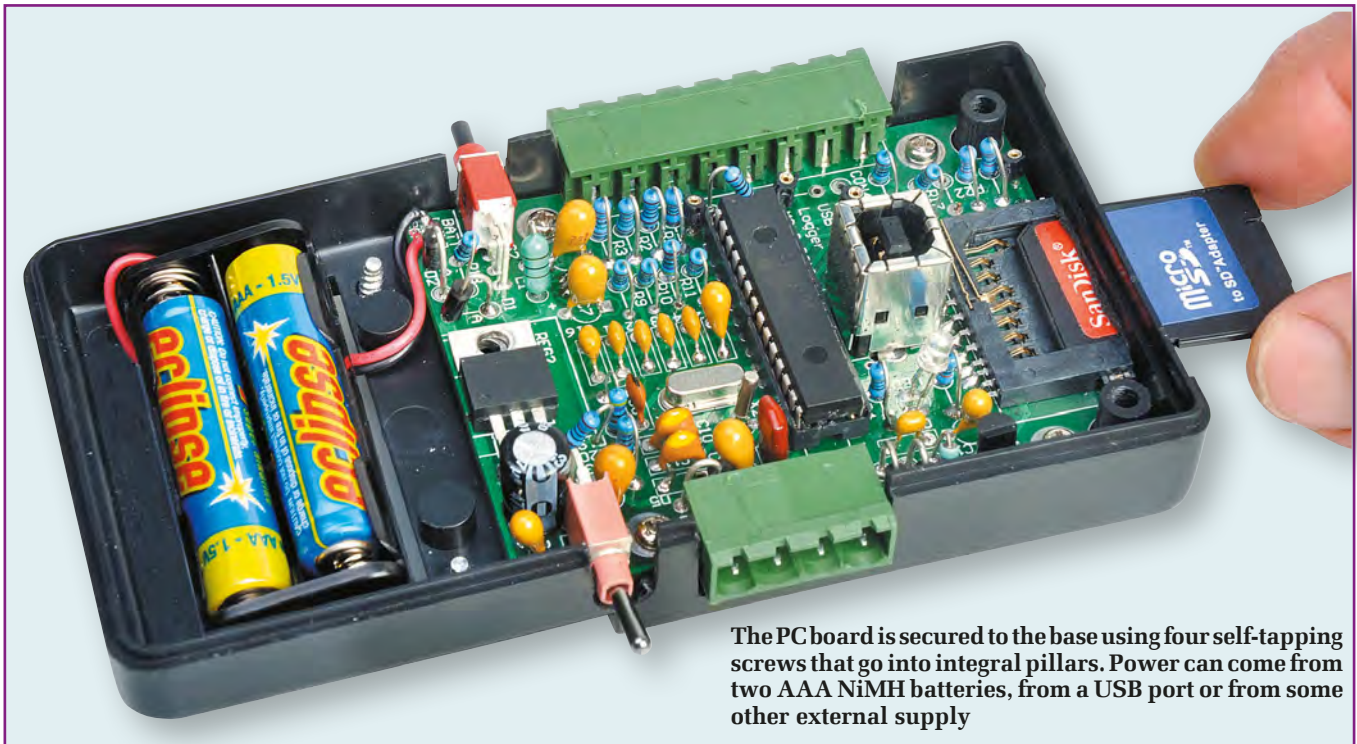

The PCB is secured to the base using four self-tapping screws that go into integral pillars. Power can come from two AAA NiMH batteries, from a USB port or from some other external supply

### Final assembly

The case requires several cutouts to be made before installing the PCB.

In all, five cutouts are required in the base of the case – one each for the two switches, one each for the two terminal blocks and a slot for the memory card. Fig.3 shows the locations of these cutouts. Each can be made by drilling a line of small holes just inside the cutout area, then breaking out the section and carefully filing to a smooth finish.

Once the cutouts have been completed, slide the PCB into position and secure it using four of the self-tapping screws supplied with the case.

Two holes are also required in the top section (lid) of the case – one for the USB socket and one for the blue 3mm LED. The front panel artwork (see Fig.4) can be photocopied and used as a drilling template.

If you purchased a kit, a sticky label will probably be supplied. If not, cut/print the label out, laminate it and attach it to the lid using some silicone sealant as the adhesive.

The 2 × AAA batteryholder is stored in the battery compartment of the case. It can either be left loose or it can be glued to the case lid.

Finally, complete the assembly by fitting the top half of the case into position and secure it using the supplied self-tapping screws. The two 20mm-long

screws go into the two top holes, while the 9mm-long screws are used for the two bottom holes. Note that the bottom two holes are accessed by removing the battery compartment cover.

That completes the assembly of the *USB Data Logger*. The next step is to install the Windows driver and the supplied PC host program.

### Installing the Windows driver

The *USB Data Logger* requires that a driver be installed on your Windows PC, so that it will work with the PC host program. The supplied LibUSB driver should work with almost all Windows versions, including 64-bit Windows 7 versions.

The step-by-step driver installation procedure for a Windows 7 machine is as follows (the procedure is similar for other Windows versions):

- 1) Download the file **usbdatalogger.zip** from the EPE website. This zipped archive contains both the Windows driver and the PC host software files.
- 2) Unzip the contents of **usbdatalogger.zip** to a directory on your hard disk (this can be done by right clicking on the file and choosing 'Extract All...').
- 3) Connect the *USB Data Logger* to your PC using a Type A to Type B USB cable. The unit can now be powered directly from the USB port

by moving switch S1's position to up.

- 4) Windows should now recognise the new device and prompt for the installation of the driver. It may then try to install the driver automatically, but this will fail because the driver won't be part of the driver database yet. You will then get the message 'Device Driver Software was not successfully installed'.
- 5) Go to Control Panel → Device Manager. A window will appear, as shown in Fig.5, and this should show the 'USB Memory Card Data Logger' device with a yellow exclamation mark next to it.
- 6) Right-click this entry and select the 'Update Driver Software' option. A window similar to the one shown in Fig.6 will appear. Choose 'Browse my computer for driver software'. An open file dialog will appear and you should navigate to the directory where you unzipped the driver files using the 'Browse' button. Choose the '**USBMemoryCardDataLogger.inf**' file that appears. For recent Windows OS versions (eg, Vista and Windows 7), a security message will appear, as shown in Fig.7.
- 7) Click 'Install this driver software anyway'. Windows will then proceed to install the driver and this may take a few minutes, depending

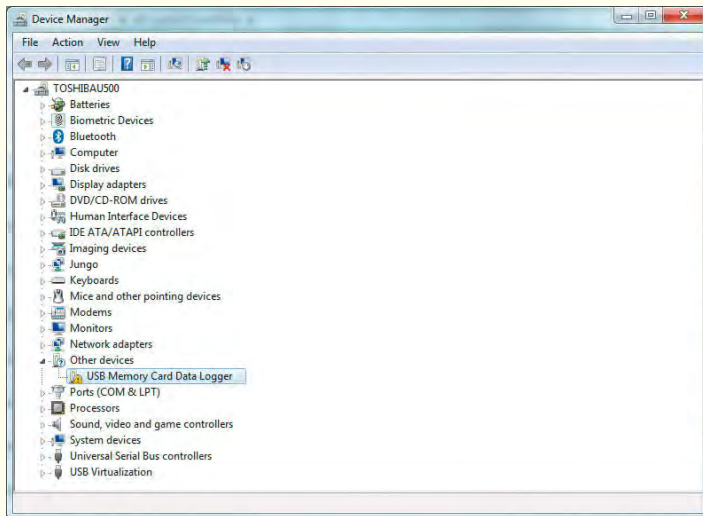

Fig.5: this is how the *USB Data Logger* entry appears in Device Manager before the Windows driver is installed

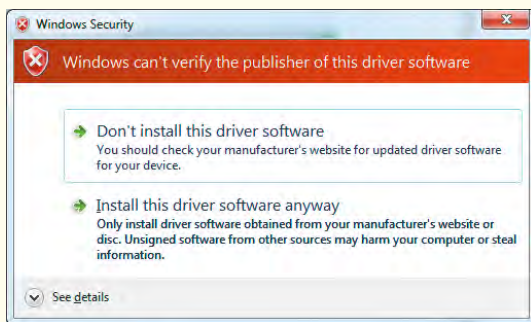

Fig.7: ignore this warning by clicking 'Install this driver software anyway'

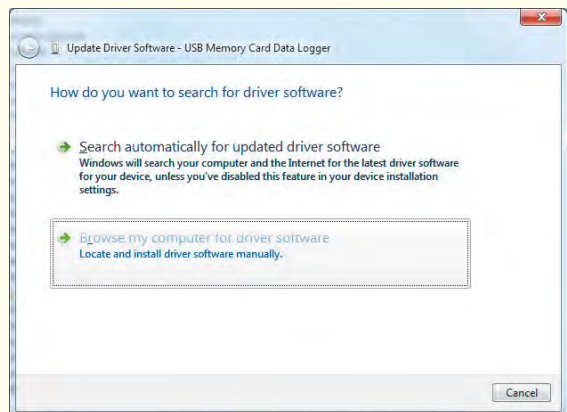

Fig.6: select 'Browse my computer for driver software' when this window appears

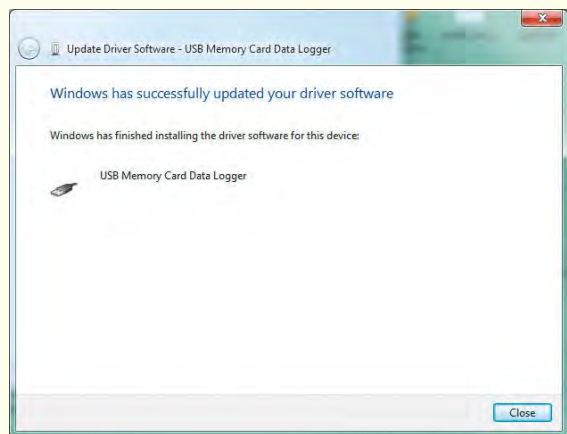

Fig.8: you'll get this message when the driver has been successfully installed

on your system. Once complete, a window should appear saying that 'Windows has successfully updated your driver software' – see Fig.8.

- 8) Return to Device Manager and check that the driver has been installed correctly. You should see the 'USB memory Card Data Logger' entry under the 'Libusb-Win32 Devices' group, without the exclamation mark (provided, of course, that the *USB Data Logger* is connected to the PC) – see Fig.9.

That completes the driver installation. Let's now describe how the unit is used.

### Launching the host software

The supplied PC host program is used to compile, simulate and load custom scripts on to the *USB Data Logger*. It's also used to configure the unit and to transfer files to and from it (including logs). The host program also synchronises the logger's real-time clock with the PC.

Note that since all files are stored in a FAT file system, the memory card can also be connected directly to a PC via a memory card reader. This would be desirable if transferring very large files (eg, more than 15MB), as the PC can access the memory card substantially faster than the *USB Data Logger's* microcontroller can.

The host software is launched by double-clicking on *usbdatalogger.exe*. This executable program is included in the zipped archive you downloaded earlier to obtain the Windows driver. You'll find it in the same folder as the extracted Windows driver.

The easiest approach is to create a shortcut to this file on your desktop. Just right-click it and choose 'Send To Desktop' from the drop-down menu. Once that is done, you can launch the program via the desktop icon. Fig.10 shows the opening dialog.

### Using the host program

The PC host program is based around a Windows GUI (graphical user interface) and was written in Visual C++. The custom scripting language compiler and parser were also written in C++ (with help from the open source parser and lexical analyser generators, Bison and Flex). The VM engine was written using the full version of the C18 compiler from Microchip.

When launched, the host program detects the *USB Data Logger* automatically. You can then write, compile and send custom programs to the unit (each script is a separate file).

The main feature here is the custom scripting language support, so let's now take a closer look at this and give some examples.

### Scripting language

The scripting language is a lightweight functional language implemented on a virtual machine that incorporates

virtual memory support. The best way to start is to see some sample code, which we present in the sections that follow. The PC host program converts the source code to machine code that then executes on the *USB Data Logger*.

## Reading the script

At this stage, it's customary to give the 'Hello World' program, as shown in Script 1 panel.

A script consists of a header declared by the **HEADER** keyword, followed by its name (which you can choose), in turn followed by the header's body enclosed in curly brackets. The header can contain settings to alter the default behaviour of the script, but in most cases, its body will be empty and the defaults can be used.

In these examples, we've used capital letters for all the keywords, to easily identify them, but the compiler accepts keywords in lower-case letters as well. However, you must use either *all* lower case or *all* upper-case letters for keywords. Usually, it is a syntax error to use a combination of upper and lower-case letters for keywords, eg, **HEADER** and *header* are both OK, but *heAder* is not.

Note that all other parts of the compiler are case-sensitive. The compiler will give useful error and warning messages, together with the line and column number of the error/warning.

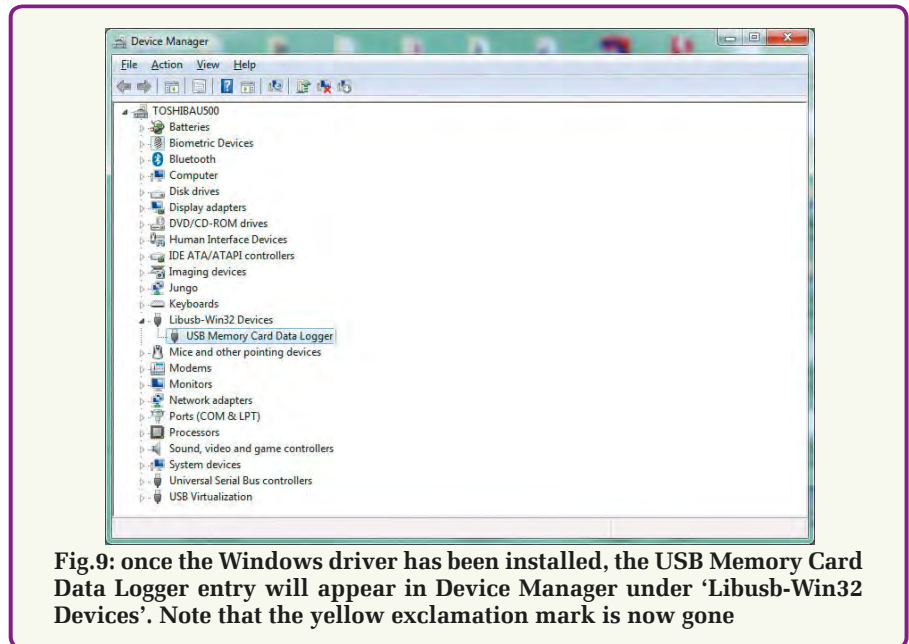

Fig.9: once the Windows driver has been installed, the USB Memory Card Data Logger entry will appear in Device Manager under 'Libusb-Win32 Devices'. Note that the yellow exclamation mark is now gone

This makes it easy to fix any syntax errors.

The header is followed by the script's body of code. This is similarly defined using the **SCRIPT** keyword, followed by the name of the script, followed by the custom script code, again enclosed in curly brackets.

Lines starting with two slashes are comments and are ignored by the compiler (as in C). Curly brackets are used to group statements, which are always terminated by a semi-colon.

In this case, the script has a single command, **PRINT**, which takes the argument "**Hello World**" (a string) and a newline. The arguments to the **PRINT** command are separated by commas. The output is actually written to the log file for that script (each script has its own log file – although it is also possible for a script to write another script's log file).

So that's our first program. Let's now run through a number of scenarios and present some custom scripts to do particular tasks. We've chosen the most common tasks that readers are likely to request (the sample code can also be downloaded from the *EPE* website).

## Reading an analogue sensor

One of the most common things you'll want to do is to log a voltage that varies over time. The *USB Data Logger* has four analogue inputs which can be used for this purpose, labelled A0 to A3.

Remember that two of the analogue inputs are for low voltages (0V to 3.6V), while the other two are for

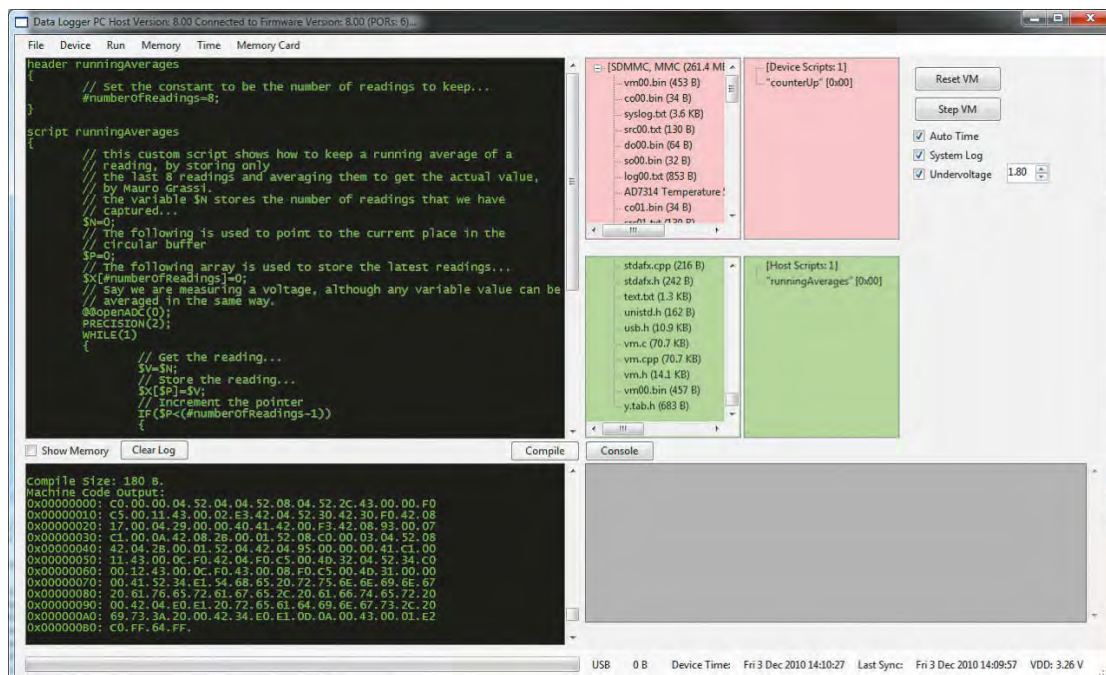

Fig.10: this screen grab shows the PC host program that's used to compile and send scripts to the *USB Data Logger*. It can also simulate scripts, change various settings and synchronise the time

## Script 1: Hello World program

```
HEADER helloWorldHeader
{
  // Empty header
}

SCRIPT helloWorldScript
{
  // Simple Hello World program for the USB Data Logger, by Mauro Grassi
  PRINT "Hello World", NEWLINE;
}
```

higher voltages (0V to 13.8V) – see Part 1, last month. They differ only in the voltage divider used.

An analogue sensor typically outputs a voltage that's proportional to the measured quantity (ie, it's ratiometric). However, although most analogue sensors are ratiometric, they may differ in the specific 'linear transfer function'. Nevertheless, they can all be used with this data logger.

### Temperature sensor

You will have to consult the datasheet for your particular sensor in order to configure it properly. However, the general method will be similar to the following example, which describes how to connect an Analogue Devices AD22103KTZ temperature sensor.

The AD22103KTZ is a 3-pin temperature sensor in a TO-92 package. Two pins are used for the supply (3.3V), while the third pin is the output. It produces an output voltage

that's proportional to temperature and which ranges from 0V to 3.3V.

To use this sensor, connect the supply rails and connect its output pin to one of the four analogue input pins. In this example, we'll use A0 as the input since it is suitable for 0V to 3.6V operation.

The transfer function of the AD22103 temperature sensor (according to its datasheet) is given by:

$$V_o = (V_s/3.3)(0.25 + 0.028T)$$

where  $V_o$  is the voltage at its output terminal,  $V_s$  is the supply voltage to the sensor and  $T$  is the temperature (between 0 and 100, in °C). For the sake of simplicity, let's assume that  $V_s = 3.3$ , so the equation becomes:

$$V_o = 0.25 + 0.028T$$

Rearranging this equation to get the temperature as a function of the output voltage gives:

$$T = (V_o - 0.25)/0.028$$

## Script 2: Analogue temperature sensor

```
HEADER myAnalogSensorHeader
{
}

SCRIPT myAnalogSensorScript
{
  // Basic Script Showing How To Read and Log an Analog Sensor,
  by Mauro Grassi
  @@openADC(0);
  PRECISION(1);
  WHILE(1)
  {
    $T=(@@readV(0)-0.25)/0.028;
    PRINT "The Temperature is: ", $T, " degrees Celsius", NEWLINE;
    SLEEP(60);
  }
}
```

A suitable custom program to read this temperature sensor and log its value every minute (ie, every 60s) is shown in Script 2 panel.

Much of this script is largely self-explanatory, but we'll run through a few basics that are not obvious. Variables (which store data as 32-bit floating point numbers) and Functions (which execute code) can be both Local and Global. Local ones can only be accessed by the custom script and are defined there. Globals can be accessed by all running scripts and are implemented internally.

**Full details of the custom scripting language's syntax, built-in functions and built-in global variables can be downloaded (in a PDF file) from the EPE website.**

### Program execution

Program execution begins at the `@@openADC(0);` statement. As mentioned, each statement ends with a semi-colon (as in C). The `@@openADC` statement is a built-in global function. Their names always start with two '@' characters (so it's easy to tell which are built-in functions and which are user-defined functions, as the names of the latter always start with just one '@' character).

This particular function takes one argument, which is the channel number. In this case, `@@openADC(0);` simply configures the A0 pin as an analogue input.

The next statement, `PRECISION(1);` is a built-in command (rather than a built-in global function). It simply configures the number of decimal points for printing floating point values, used later on to display the temperature.

Next, the program enters its 'main loop', where it will execute its infinite loop. This is the `WHILE(1)` built-in command that executes the block of code enclosed in its curly brackets whenever the condition is non-zero (as in C).

The next line in the script reads: `$T=(@@readV(0)-0.25)/0.028;` and should be self-explanatory. There are built-in rules for which arithmetic operators take precedence over others (eg, multiplication takes precedence over addition, so that  $8 \times 3 + 2 = 26$  rather than 40), but you can use brackets whenever in doubt. Apart from the four arithmetic operators, you can also use the '^' (exponent) and '%' (modulo) operators (unlike in C where '^' is used for XOR).



The above statement simply computes the temperature (\$T) by reading the voltage at channel 0 (using the built-in global function `@@readV`, subtracting 0.25 from the value and dividing the result by 0.028). It stores the result in the local variable \$T.

Local variables are 'local' to the current script, so cannot be accessed by other running scripts (as opposed to global variables which can). Local variables' names always start with a single '\$' character. Global variables' names always start with two '\$' characters (in analogy with global and local functions).

Once the temperature is computed and stored in the local variable \$T (which is a 32-bit floating point value), the next statement logs the result to the memory card. A typical line would read: *The temperature is: 21.4 degrees Celsius*

## PRINT command

**PRINT** is a built-in command and it takes its argument as a comma-separated list. Each item in the list is either a constant string, enclosed in quotes ("), or an expression (in this case the value of \$T), or a special print command. In this case, we are using the **NEWLINE** print command to add a line return to the log file.

The last line is another built-in command: **SLEEP**. It takes a single numeric argument, which is the number of seconds to suspend execution of the script. It simply suspends the script for the specified period, letting other scripts run. The script will be woken after this period and

begin execution after the **SLEEP** command.

In this case, since it is the last statement in the **WHILE** loop, a new value will be read and logged and the process will repeat indefinitely.

Another command for sending a script to sleep is the **SLEEPUNTIL** command (or `sleepUntil` if in lowercase). Unlike the **SLEEP** command, it takes an absolute time (in the future), as argument. For example, writing: **SLEEPUNTIL(16:00:10)**; will suspend the execution of the script until just after 4pm.

Now suppose you wanted to display the reading in degrees Fahrenheit as well. Then you could change the **PRINT** statement to:

```
PRINT "The temperature is: ", $T, "
degrees Celsius, or ", ($T*(9/5)+32),
" degrees Fahrenheit", NEWLINE;
```

## Logging the time

Another thing you can do is timestamp the logging. You can do this using one of the built-in print functions, **PF(#TIME)**, where **PF** stands for **PRINT FUNCTION** and is used with the built-in **PRINT** command. In this case, you would replace the **PRINT** statement with the following:

```
PRINT PF(#TIME), " The temperature
is: ", $T, " degrees Celsius", NEWLINE;
```

## Reading a frequency input

Reading a frequency rather than a voltage is just as easy. Script 3 panel shows the details.

In this case, after initialising the frequency input and setting the **PRINT**

**PRECISION** to three decimal places, the main loop begins executing and logging the frequency on that pin in Hertz, every five seconds.

Note that the frequency can be anywhere between 0.1Hz and 192kHz. To cover this wide range, three different modes are used – LOW, MEDIUM and HIGH frequency – and the mode will be changed automatically by the firmware to suit the frequency (to achieve the best accuracy).

For example, for frequencies below about 1kHz, a special LOW FREQUENCY mode is used, whereas above around 12kHz a special HIGH FREQUENCY mode is used instead.

## Reading a counter input

Reading a 32-bit counter value is just as easy as logging a frequency input. In this case, simply replace the `@@openFrequency(0)`; statement by either a `"@@openRisingCounter"` or `"@@openFallingCounter"` statement (selecting to increment the count on a rising or falling edge). In addition, replace the `@@readFrequency(0)`; statement by a `"@@readCounter(0)"` statement (of course, you should change the **PRINT** statement to suit your needs).

Note that for counters, the value is cleared (set to 0) whenever it is opened. So the counter can be 're-opened' to clear it.

## Reading an I<sup>2</sup>C sensor

Let's now take a look at how to read from a digital temperature sensor using the I<sup>2</sup>C bus.

For this example, we are going to use the Analog Devices AD7414 temperature sensor. This is a 10-bit temperature-to-digital converter, using the I<sup>2</sup>C bus.

The one we are using comes in an SOT-23 6-pin package. Two pins are for the supply voltage, which is 3.3V, meaning that it can be powered directly from the *USB Data Logger*. Another two pins, **AS** and **ALERT**, are the input and output respectively.

The **AS** input can be used to choose one of three I<sup>2</sup>C addresses (to potentially use more than one of these on the same bus). These three addresses are chosen by a high, low or floating pin. We've configured ours so that the I<sup>2</sup>C address is 0x92 (hexadecimal).

The **ALERT** output pin will change, if configured, when the temperature exceeds the set limits. We are not using this feature in this example, but you

## Script 3: Reading a frequency input

```
HEADER myFrequencySensorHeader
{
}

SCRIPT myFrequencySensorScript
{
  // Basic Script Showing How To Read and Log a Frequency Input,
  by Mauro Grassi
  @@openFrequency(0);
  PRECISION(3);
  WHILE(1)
  {
    PRINT "The Frequency is: ", @@readFrequency(0), " Hz", newline;
    SLEEP(5);
  }
}
```

## How the USB Data Logger functions

This *USB Data Logger* is different to most other data loggers, as it incorporates support for a scripting language. It is supplied with its own compiler and virtual machine (VM) engine.

A virtual machine is basically a software implementation of a 'real' machine. In this case, we are referring to a 'processing machine', ie, a processor that can execute instructions to add and subtract numbers, branch on a certain condition and call subroutines, among others. An example of a well known VM is the PICAXE, which runs on a PIC.

This virtual machine can execute its own custom machine code, but unlike a microcontroller, it is implemented in software. In this case, the firmware in the PIC18F27J53 microcontroller implements the VM, and the Windows PC host implements both the VM and the compiler for this language. The source code is compiled into machine code and stored on a file on the memory card.

The VM engine is capable of multitasking, which means more than one custom script can run at a time. It also incorporates a virtual memory engine as well (refer to the PDF file on the *EPE* website for further details).

This means that, unlike a PICAXE, the RAM (random access memory) and program space available to each running script is much bigger than the few kilobytes available on the PIC itself. It is cached to the memory card, and only a small amount is present in the microcontroller's memory at any time. Any accesses outside the microcontroller's memory cause a 'cache miss' and go to disk (ie, to the memory card). This will be explained in more detail in Part 3 next month.



This view shows the completed *USB Data Logger* with the memory card plugged in

The `@@putI2CByte` function returns a value of 1 if the command succeeded, or 0 otherwise. For example, if there is no sensor connected, the function will fail. We check for this using the built-in command `IF(){ } ELSE { }` which executes the first block of code if the condition evaluates to non-zero or the last command block otherwise.

If the function returns 0, it logs an "ERROR" message and goes to sleep for 30 seconds before retrying.

We read from the sensor using the built-in global function `@@getI2C`. This function takes two arguments. The first is the address and the second is the number of bytes to read.

Note that the address register inside the sensor itself will automatically increment on each read, so we use this function to read the bytes at addresses 0 and 1. Again, it returns 1 if successful or 0 otherwise.

If successful, the data is written to an internal buffer which is a global variable `$$I2C`. Global variables are defined for all scripts and their names always start with two '\$' characters, as opposed to local variables. In this case, we use the round brackets '(')' to specify offsets of 0 and 1 to the buffer. This reads the data as a byte, whereas using square '[' ]' brackets reads it as a 32-bit floating-point number.

In this case, `$$I2C(0)` represents the eight MSBs (most significant bits) of the 10-bit temperature, while the two MSBs (most significant bits) of `@@I2C(1)` represent the two LSBs of the

could write your own custom script to do just this.

The remaining two pins are the SCL (clock) and SDA (data) lines of the I<sup>2</sup>C interface. These are connected to digital inputs D0 and D1 respectively on the *USB Data Logger*.

Reading the datasheet of the AD7414 sensor tells you how to read the temperature value. This particular sensor is used by reading and writing to four internal 8-bit registers. One register (at address 0) holds the most significant eight bits of the value (you can just read this for a good approximation, or you can read the second register as well to retrieve the extra two bits for full resolution).

The 'Configuration Register' is at address 1 and this holds the extra two bits of temperature information. It also holds extra bits to control the power to the sensor (you can put it in standby to save power and set the alert function mentioned earlier). The other two registers hold the minimum and maximum temperatures for the alert function, which we don't use in this example.

The address writing works as follows: the first write sets the address of the next write. For example, if we want to write to the register at address 2, we first write 2 and then the value to write to this address.

Similarly, for reading, you first write the address, then read from the sensor.

So to read the value at address 1, for example, you first write 1 and then read from the device (one byte).

A program to read the temperature from the AD7414 is shown in Script 4.

In this script, we first define a constant `#I2C_ADDRESS` in the header (it can also be defined in the script). We then use it in all places of the code that take the I<sup>2</sup>C address of the sensor as an argument. This is a good technique, since if we later want to change the I<sup>2</sup>C address, we only need to change one value (the 0x92) rather than change all places where it is used.

Defined constants always start with a '#' character, which is supposed to be reminiscent of the '#define' preprocessor directive in C. Note that these define constants can be redefined, but the compiler will warn you if this happens.

We first open the I<sup>2</sup>C bus and set it to run at 400kHz, using the built-in global function `@@openI2C`. We then set the precision to three decimal places and enter the main loop.

We declare a local variable called `$RESULT` which takes the value returned by the built-in global function `@@putI2CByte`. The latter takes two arguments. The first is the I<sup>2</sup>C address, while the second is the single byte to write to the I<sup>2</sup>C bus. In this case, we simply write 0 since we are interested in reading addresses 0 and 1.

## Script 4: AD7414 digital temperature sensor

```

HEADER myI2CHeader
{
    // Basic Script Showing How To Read and Log a Temperature from an:
    // AD7414 digital I2C sensor, by Mauro Grassi.
    // Define a Constant which is the sensor's I2C Address
    #I2C_ADDRESS=0x92;
}

SCRIPT myI2CScript
{
    // Open the I2C bus, running at 400kHz...
    @@openI2C(400);
    PRECISION(3);
    WHILE(1)
    {
        // Write the Address Register
        $RESULT=@@putI2CByte(#I2C_ADDRESS, 0);
        IF($RESULT)
        {
            // Read Two Bytes From The Sensor (the address increments
            automatically)
            $RESULT=@@getI2C(#I2C_ADDRESS, 2);
            IF($RESULT)
            {
                // Compute the Temperature
                $T=$$I2C(0) + (($I2C(1) & 0xC0)/256.0);
                PRINT "The Temperature is ", $T, " degrees Celsius", NEWLINE;
            }
        }
        ELSE
        {
            PRINT "Error", NEWLINE;
        }
        SLEEP(30);
    }
}
    
```

Reproduced by arrangement  
with SILICON CHIP  
magazine 2012.  
[www.siliconchip.com.au](http://www.siliconchip.com.au)

10-bit temperature. The temperature is stored in the local variable \$T. The script then logs the value and ends up at the **SLEEP(30);** command, which suspends execution for 30 seconds, before the cycle repeats.

Note that it's possible to sleep for a variable amount on each cycle. For example, in the script presented above, if the I<sup>2</sup>C temperature sensor read gives an error, we could choose to retry in three seconds, rather than 30. You would simply move the **SLEEP(30);** command inside the first block of the **IF** statement and add a **SLEEP(3);** command after the **PRINT "Error", NEWLINE;** command.

### Conclusion

The general pattern in all these cases is that each script begins by executing an initialisation sequence. It then enters the main loop, executes some

code and then goes to sleep until the next cycle begins.

Of course, what you do is up to you. The VM (virtual machine) engine is multitasking, so scripts are suspended after a certain amount of time if they don't voluntarily go to sleep!

As stated, the ability to run custom scripts from the memory card allows the unit to interface to almost any sensor you can think of, as well as to do novel things, such as analyse the data or monitor the sensors (ie, take different actions on certain conditions being met).

In next month's final article, we will run through the PC host program and show you how to compile and run custom scripts. More details and examples, including a "Tips and Tricks" section on how to use the custom scripting language will be given as well.

Need a small and  
cost-effective device?  
Look no further.



### PoScope Mega1+

Smallest USB 2.0 portable 1MS/s oscilloscope  
Data acquisition of analog and digital signals  
Data recording  
Export to CSV, XLS, PDF and HTML  
Simple usage of advanced features  
Examples for C++, VB, Delphi and LabView  
Free software and updates



### PoKeys 56

Smallest USB HID or ETHERNET I/O interface  
Keyboard and joystick simulator (USB)  
55 digital I/O (configurable)  
LCD and LED matrixes driver  
6 PWM outputs, 26 encoder inputs  
Supports up to 10 I2C, 1-Wire sensors,  
up to 7 analog sensors  
Expandable with PoNet  
Free software and web interface (Ethernet)

Visit [www.poscope.com](http://www.poscope.com)



# Jump Start

By Mike and Richard Tooley

Design and build circuit projects dedicated to newcomers, or those following courses taught in schools and colleges.



**W**ELCOME to *Jump Start* – our new series of seasonal ‘design and build’ projects for newcomers. *Jump Start* is designed to provide you with a practical introduction to the design and realisation of a variety of simple, but useful, electronic circuits. The series will have a seasonal flavour, and is based on simple, easy-build projects that will appeal to newcomers to electronics, as well as those following formal courses taught in schools and colleges.

Each part uses the popular and powerful ‘Circuit Wizard’ software package as a design, simulation and printed circuit board layout tool. For a full introduction to Circuit Wizard, readers should look at our previous *Teach-In series*, which is now available in book form from Wimborne Publishing (see *Direct Book Service* pages in this issue).

Each of our *Jump Start* circuits include the following features:

- **Under the hood** – provides a little gentle theory to support the general principle/theory behind the circuit involved

- **Design notes** – has a brief explanation of the circuit, how it works and reasons for the choice of components
- **Circuit Wizard** – used for circuit diagrams and other artwork. To maximise compatibility, we have provided two different versions of the Circuit Wizard files; one for the education version and one for the standard version (as supplied by *EPE*). In addition, some parts will have additional files for download (for example, templates for laser cutting)
- **Get real** – introduces you to some interesting and often quirky snippets of information that might just help you avoid some pitfalls
- **Take it further** – provides you with suggestions for building the circuit and manufacturing a prototype. As well as basic construction information, we will provide you with ideas for realising your design and making it into a complete project
- **Photo Gallery** – shows how we developed and built each of the projects.

## Merry Christmas

In this month’s *Jump Start* we shall be delving into the world of analogue electronics and building a simple amplifier that can be used with portable audio equipment, such as CD and MP3 players, tablets and laptop computers – perfect for all those Christmas gifts that don’t produce quite enough sound!

### Under the hood

Our *iPod Speaker* uses only one integrated circuit, two small power transistors and a handful of other readily available low-cost components. The *iPod Speaker* is designed for building into a small loudspeaker enclosure, and will provide sufficient power for a quiet environment such as a bedroom or study. Two units will be required for stereo operation (each fitted with its own internal amplifier) but, if required, a single ‘*Speaker*’ can be easily wired for mono operation.

The simplified block schematic of our *iPod Speaker* is shown in Fig.1. The operational amplifier (a low-cost

### Coming attractions

Issue	Topic	Notes
May 2012 ✓	Moisture alarm	
June 2012 ✓	Quiz machine	Get ready for a British summer!
July 2012 ✓	Battery voltage checker	Revision stop!
August 2012 ✓	Solar mobile phone charger	For all your portable gear
September 2012 ✓	Theft alarm	Away from home/school
October 2012 ✓	Wailing siren, flashing lights	Protect your property!
November 2012 ✓	Frost alarm	Halloween “spooky circuits”
December 2012 ✓	Mini Christmas lights	Beginning of winter
January 2013 ✓	iPod speaker	Christmas
February 2013	Logic probe	Portable Hi-Fi
March 2013	DC motor controller	Going digital!
April 2013	Egg Timer	Ideal for all model makers
May 2013	Signal injector	Boil the perfect egg!
June 2013	Simple radio	Where did that signal go?
July 2013	Temperature alarm	Ideal for camping and hiking
		It ain’t half hot ...

standard 741 device) provides a modest  $\times 10$  voltage gain and sufficient output voltage to drive the two complementary power transistors.

To aid portability, our *iPod Speaker* is designed to operate from a pair of rechargeable 9V (PP3-type) batteries. These are available at reasonable cost from a number of suppliers and can usually be expected to operate satisfactorily for several hundred charge-discharge cycles.

The batteries used with our prototype *iPod Speaker* were each rated at 200mAh and so can be expected to operate for between five and 10 hours before needing a recharge. Non-rechargeable batteries can also be used with the *iPod Speaker*, but battery life will depend very much on volume level.

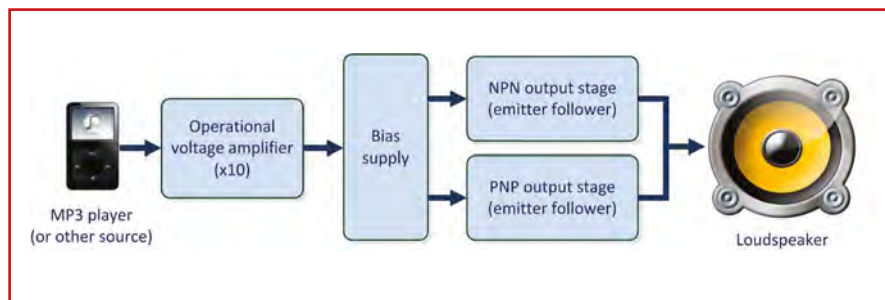

**Fig.1. Simplified block schematic of our iPod Speaker**

**Design notes**

In earlier instalments of *Jump Start*, we showed how an operational amplifier (op amp) could be used as a comparator (see July '12 *EPE*, page 49 and Nov '12 *EPE*, page 49). In this month's instalment, we will be using

an operational amplifier to provide voltage gain rather than to compare two input voltages.

A simple operational voltage amplifier is shown in Fig.2. Note that, since most operational amplifiers require a symmetrical supply (typically  $\pm 5V$  to  $\pm 15V$ ), we have 'split' the supply and made use of two (nominal 9V) batteries. This dual supply is also ideal for use with our two output transistors, as we shall see later.

The voltage gain of the arrangement shown in Fig.2 is determined by the ratio of resistor R3 to R2 (in this case 10). A typical input of 100mV from an MP3 player (or similar signal source) will result in an output of 1V (enough to drive a small loudspeaker).

However, there's still one problem: the operational amplifier cannot provide sufficient output current to drive the relatively low impedance of a loudspeaker (usually between 8 $\Omega$  and 40 $\Omega$ ). Because of this, we need to introduce a further stage in order to provide the necessary current gain.

**Complementary pair**

This can be easily accomplished using a pair of complementary *NPN* and *PNP* transistors operating as emitter followers (and thus producing current gain rather than voltage gain), as shown in Fig.3.

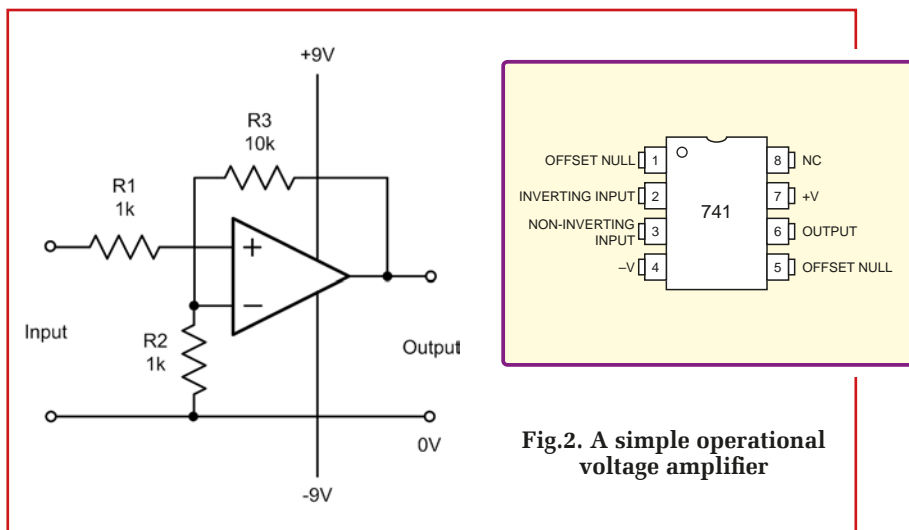

**Fig.2. A simple operational voltage amplifier**

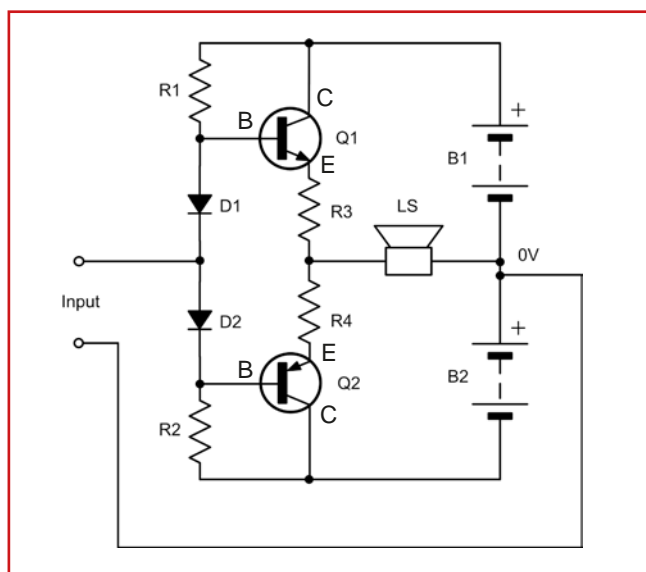

**Fig.3. A complementary current amplifier stage based on a pair of NPN and PNP transistors and using dual supplies (note that transistors Q1 and Q2 should ideally have matched electrical characteristics)**

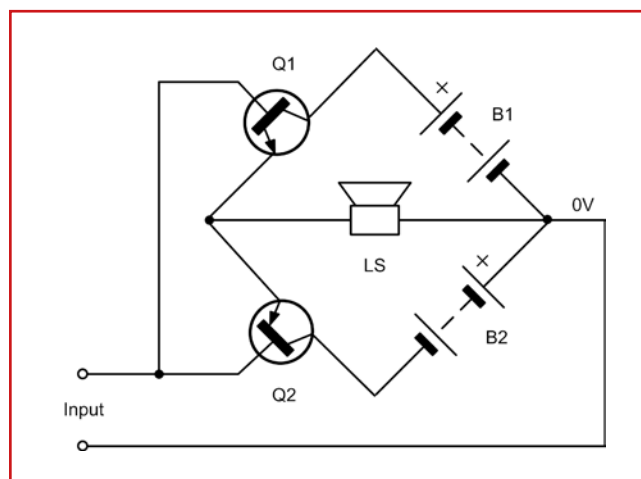

**Fig.4. A simplified version of Fig.3 drawn in the form of a bridge circuit**

A complementary symmetrical arrangement similar to that shown in Fig.3 is widely used in the output stages of low and medium-power transistor amplifiers. The two low-value resistors, R3 and R4, help to improve the thermal stability of the output, while the necessary bias current for the two transistors is provided by the series resistor/diode chain formed by R1, D1, D2, and R2.

The small amount of forward bias applied to Q1 and Q2 helps avoid crossover distortion and improves overall linearity. The values chosen

for R1 and R2 are designed to produce a small standing current of around 10mA to 20mA in Q1 and Q2.

Fig.4 shows how the complementary arrangement in Fig.3 takes the form of a bridge (see Nov'12 2012 *EPE*, page 49). In this circuit, we have simply omitted the bias and thermal protection components. In Fig.4, the input signal is effectively applied to the base connections of Q1 and Q2 and the output taken from the central arm of the bridge (ie, from the junction of the two emitters to 0V).

In Fig.5 we have shown what happens when the input is driven by a signal. Put simply, this has the effect of unbalancing the bridge and causing current to flow in the load in a direction determined by the polarity of the input voltage. We will be looking at this circuit again in a later instalment of *Jump Start!*

approach and it includes waveforms displayed using Circuit Wizard's virtual oscilloscope display.

Notice how the output waveform (shown in blue) is almost an identical replica of the input voltage (shown in red), but very slightly smaller in amplitude. This confirms that the voltage gain (as expected from an emitter follower) is slightly less than unity (one).

**Adding the op amp**

Having checked the operation of the output stage (formed by transistors Q1, Q2 and associated bias components) it is a relatively simple matter to add the operational amplifier stage, as shown in Fig.7. Notice that we have connected the feedback resistor R5, from the output to the inverting input of IC1. We have also added a small value capacitor, C2, in parallel with R5 in order to roll-off the high frequency response.

The preset potentiometer ('resistor') VR1, provides us with a means of setting the input voltage to IC1. In practical operation this resistor is set to a value that avoids

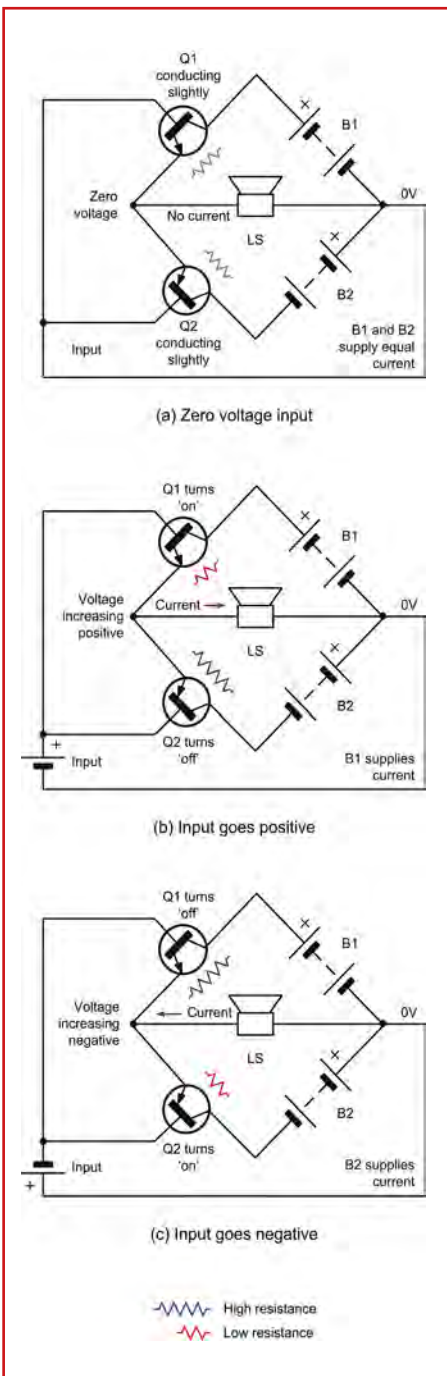

Fig.5. Operation of the bridge-configured output stage

**Get real**

It can be useful and instructive to check the operation of the bridge-configured output stage using Circuit Wizard. Fig.6 shows one possible

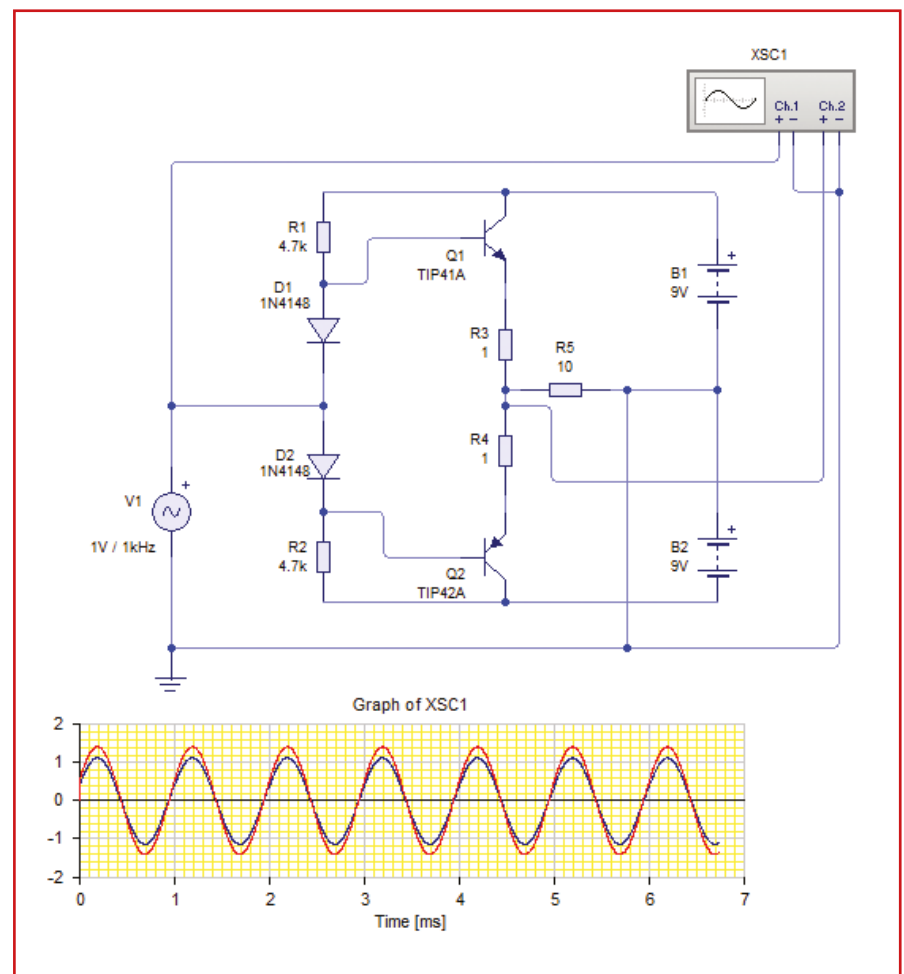

Fig.6. Testing the output stage in Circuit Wizard

the amplifier being over-driven, thus limiting distortion at high volume levels. The additional voltage gain of IC1 is evident from the output waveforms displayed in Fig. 7 (note that, once again, we have used red for the input signal and blue for the output).

**A note regarding Circuit Wizard versions:**

Circuit Wizard is available in several variants; Standard, Professional and Education (available to educational institutions only). Please note that the component library, virtual instruments and features available do differ for each variant, as do the licensing limitations. Therefore, you should check which is relevant to you before purchase. During the Jump Start series we aim to use circuits/features of the software that are compatible with the latest versions of all variants of the software. However, we cannot guarantee that all items will be operational with every variant/version.

**Fig.7. Testing the complete iPod Speaker with a signal source and virtual oscilloscope**

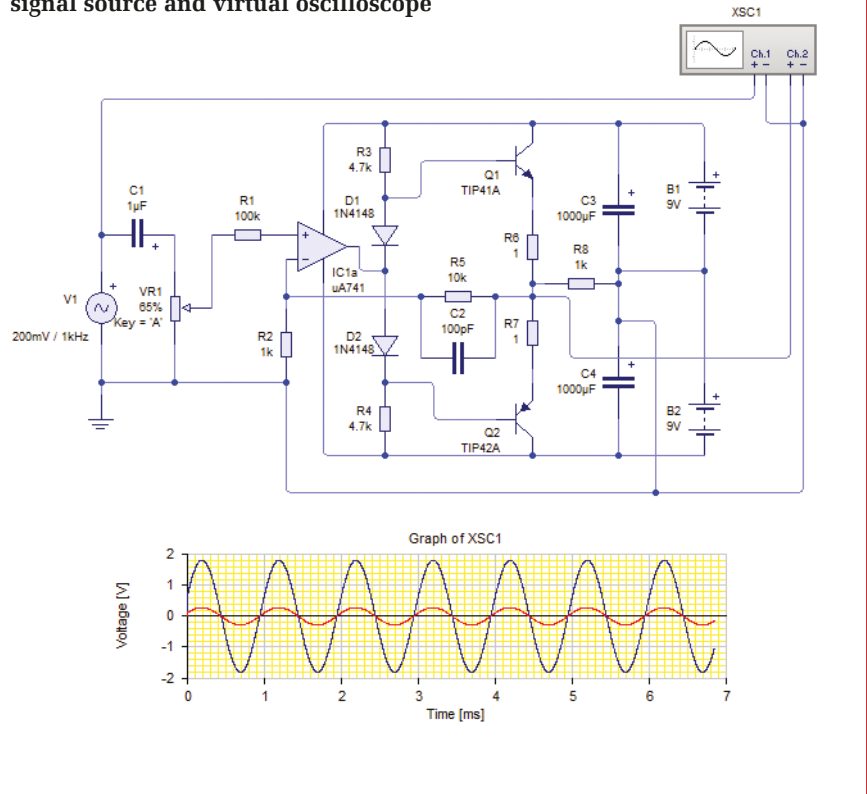

**iPod Speaker – using Circuit Wizard**

OUR final iPod Speaker circuit diagram, with a couple of tweaks to make it suitable for manufacture, is shown in Fig.8. The AC signal source and oscilloscope shown previously (see Fig.7) have been replaced with two two-pin screw terminal connectors to connect the physical input and output to the circuit. If you have already entered and simulated the circuit it will be quite easy for you to make the same modifications.

**Circuit board**

Our prototype PCB design is shown in Fig.9. The board is reasonably compact, allowing it to be easily hidden in a compact speaker enclosure. Note that the closely mounted transistors must be physically separated.

If you are intending to use a higher voltage power supply, in order to obtain more output power, then you will need to allow extra clearance around the transistors for mounting the heatsinks when designing your PCB.

Our manufactured prototype PCB is shown in Fig.10 (the board shown is in fact an early prototype, prior to adding an additional connector for B2 to the design, as shown in our Circuit Wizard artworks).

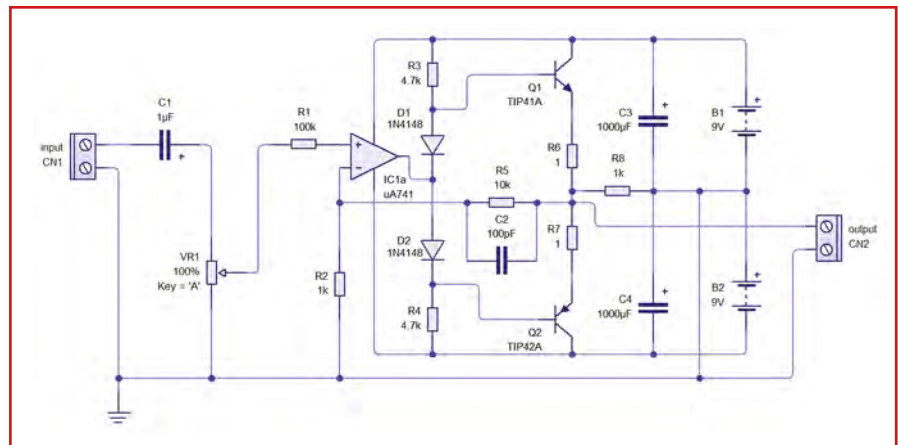

**Fig.8. The complete circuit of our iPod Speaker**

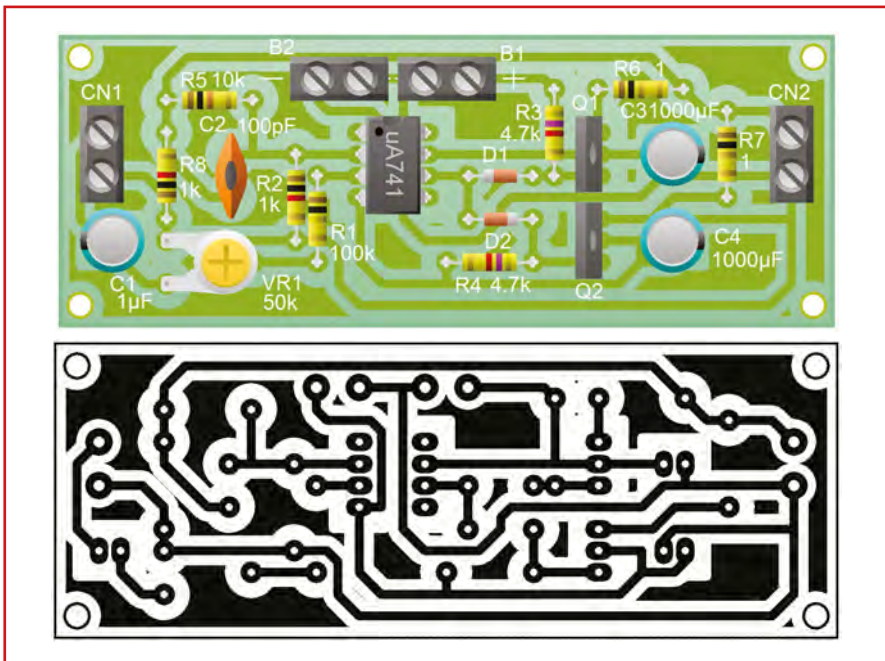

Fig.9. Printed circuit board (PCB) component layout and track layout viewed 'through' the board for the iPod Speaker. Final size is 92mm x 34mm



Fig.10. Our manufactured prototype iPod Speaker (see text)

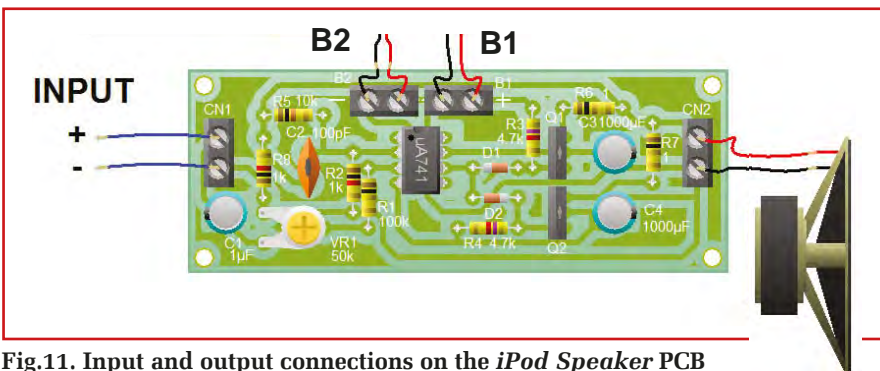

Fig.11. Input and output connections on the iPod Speaker PCB

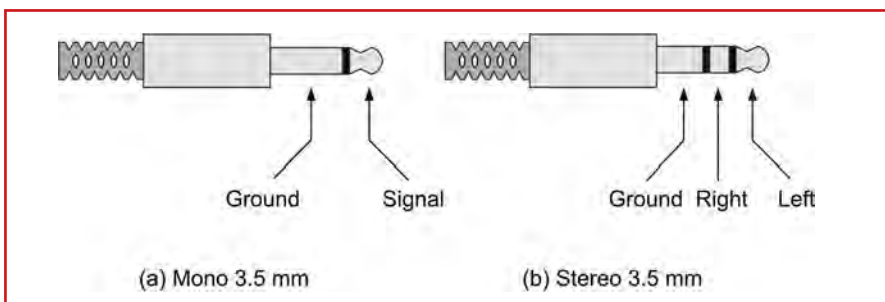

Fig.12. 3.5mm jack plugs (a) mono and (b) stereo types

You will need...

iPod Speaker

- 1 PCB, code 884, available from the EPE PCB Service, size 92mm x 34mm
- 4 Two-way PCB mounting terminal blocks
- 2 battery clips, plus leads for a PP3-type battery
- 2 9V (PP3-type) batteries (preferably 200mAh rechargeable NiMH types)
- 1 8-pin low-profile DIL socket
- 1 3.5mm jack plug (stereo or mono, see text)
- 1 miniature loudspeaker (8Ω to 40Ω)
- 4 PCB mounting pillars

Semiconductors

- 1 741 operational amplifier (IC1)
- 1 TIP41A NPN transistor (Q1)
- 1 TIP42A PNP transistor (Q2)
- 2 1N4148 signal diodes (D1 and D2)

Resistors

- 1 100kΩ (R1)
- 2 1kΩ (R2 and R8)
- 2 4.7kΩ (R3 and R4)
- 1 10kΩ (R5)
- 2 1Ω (R6 and R7)
- VR1 100kΩ miniature preset

Capacitors

- 1 1µF 50V radial electrolytic (C1)
- 1 100pF miniature ceramic (C2)
- 2 1000µF 25V radial elect (C3, C4)

CIRCUIT WIZARD

Order direct from us on 01202 880299

By integrating the entire design process, Circuit Wizard provides you with all the tools necessary to produce an electronics project from start to finish – even including on-screen testing of the PCB prior to construction!

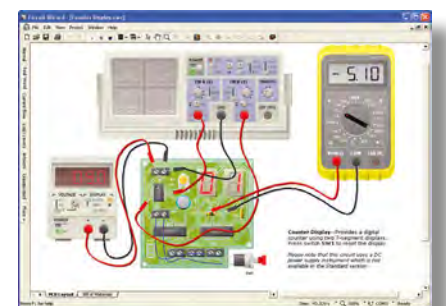

This software can be used with the Jump Start and Teach-In 2011 series (and the Teach-In 4 book). Standard £61.25/Professional £91.90 inc. VAT



Fig. 11 shows the appropriate input/output connections as well as the arrangement of two 9V (PP3-type) batteries to produce a split power supply. Note that both CN1 and CN2 have a common ground connection (the lower connection on either side as you look at the PCB). Failing to connect the input correctly could cause instability, hum or both!

### Connecting up

To connect your amplifier to a portable device with a headphone or line out socket you may well wish to wire up a standard 3.5mm jack plug. Fig.12 shows the connections for both mono and stereo 3.5mm jack plugs.

Male jack plugs may be purchased individually with solder tags for each connection, often with a screw-on plastic cover. You will then need to wire the connector using a suitable three-core cable (suppliers often sell specific stereo audio cable for this purpose).

Alternatively, you may find it easier to modify one end of an existing moulded cable eg, a male-male jack lead or headphone extension lead. In

either case, take care when preparing the ends as they can be quite small and fiddly to work with. Audio cables often consist of two sheathed cores for each audio channel (generally white and red) surrounded by a copper shroud mesh which form the common ground.

By their very nature, amplifier circuits tend to be quite sensitive and any errors in manufacture or poor soldered joints can have an impact on operation. Hence, they can be a little more tricky to get right than DC circuits and you should try and take extra care to work to the highest of standards.

### In the gallery

This month's gallery shows some examples of students work. Here they used two amplifier PCBs to create a stereo amplifier for a phone or MP3 player, with one PCB amplifying each of the left and right channels. A stereo 3.5mm jack plug was connected as discussed above to CN1 of each board. An SPST switch was also included to turn the amplifier on and off, and an LED (with appropriate series resistor mounted off-board) was added to indicate operation.

Note that an off-board volume control was not added; instead, the variable resistors on both channels were set to achieve optimal and equal gain for each channel (without noticeable distortion) and the listening volume was controlled by the controls on the device itself.

The enclosures were laser cut from 3mm MDF and assembled with a hot-melt glue gun. This represents a quick and easy way to manufacture a case.

It is important to note that the design of the enclosure can have a dramatic effect on the quality of sound produced and this might have an influence on your design. In fact, there's a great deal of advice on the Internet on how to create effective speaker enclosures. The materials used and the attachment method of the speaker(s) to the case also impact on the sound properties.

### Next month

In next month's *Jump Start*, we shall be returning to the world of digital electronics. Invaluable for trouble shooting a wide variety of digital circuits, our *Jump Start* project is a versatile Logic Probe.

## Photo gallery...

The Gallery is intended to show readers some of the techniques that they can put to use in the practical realisation of a design, such as PCB fabrication and laser cutting. This is very important in an educational context, where learners are required to realise their own designs, ending up with a

finished project that demonstrates their competence, skills and understanding. The techniques that we have used are available in nearly every secondary school and college in the country, and we believe that our series will provide teachers with a tremendously useful resource!



Stereo amplifier circuits designed and manufactured by Year 10 students studying on a day release BTEC First Diploma in Engineering programme at Chichester College. See if you can come up with something different or improve on these basic designs!

## Getting to grips with Interrupts

**T**HIS month, we move back to the simple PIC18F circuit we introduced in September last year (*Starting out with PICs*) so we can start looking at one of the more complex features of the microcontroller – interrupts. We investigate why they are difficult to understand, how to get over this difficulty and demonstrate why they are so useful.

We are extending the circuit very slightly by adding an LED and a resistor so we can get some visual feedback on what the microcontroller is doing. The ‘new’ circuit is shown in Fig.1.

We have connected the LED to one of the bits of PORTB, a choice made only for convenience of wiring. PORTB is the appropriate I/O port to use, as the datasheet explains, it has high enough output power capability to drive an LED directly. PORTA has weaker output drive capability, and while it may drive an LED dimly, its use is not recommended.

We will continue with the use of a breadboard for this circuit. Although we will be producing a general purpose development board later on, during these early stages of experimentation with a new microcontroller, drilling boards and soldering components is a waste of money and effort, at least until we are clear on what the final circuit will look like.

When you have used a particular processor a number of times, you may be more confident and go straight to a PCB. We are going to be playing with a number of new concepts here though, and so we proceed with caution. Assembling simple circuits on a breadboard is quick too. You can see our final breadboard layout in Fig.3.

### Getting started

To explore interrupts properly, we need an operational microcontroller, and before we write any code, we have to decide on what config bit settings we will use.

Remember that the config bits are data that are stored in the flash memory of the processor, just like code (although in a different area) that affects how the processor will operate *before* the code starts to run. Get these settings wrong and your code will either not start, or run erratically. A little thought up-front will save hours of debugging (with even the simplest of programs) and avoid the need to drag out the oscilloscope.

In the Sept '12 issue we discussed the basic config settings that are appropriate to our chosen PIC18F27J13 processor, so now it's time to work out

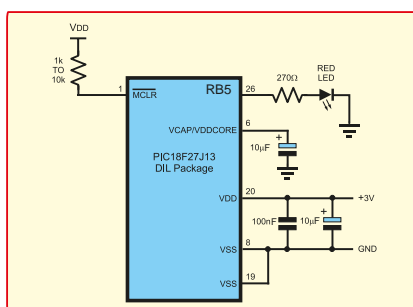

Fig. 1. Revised minimal circuit diagram

how to set them within our project (Fig.2).

### Config bit settings

The syntax for setting configuration bits is a bit confusing, and is rather difficult to trace down. We eventually tracked them down within the MPLAB help system. To see them from the main menu, select Help -> Topics -> PIC18 Config Settings. In the dialog box that appears, select our processor PIC18F27J13 (found under the PIC18F2xxx entry.)

There should be a one-to-one mapping between the names of config bit settings found in the datasheet and

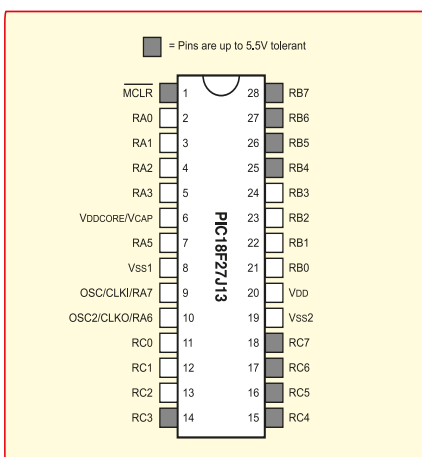

Fig.2. The PIC18F27J13 processor is available in our favorite 28-pin DIL format, and surface mount for the more daring. It has 128KB Flash memory providing for over 65,000 instructions, and 3760 bytes of RAM. 19 I/O pins, four timers and the usual ADC, SPI, I<sup>2</sup>C and UART peripherals provide for a wide range of applications.

This processor will operate across 2.15V to 3.6V, making it ideal for battery operation from two AA cells.

the settings found in this list; this is mostly true, but there are the odd differences thrown in for fun – the FOSC bits, for example, are called OSC in MPLAB.

To set a config bit, you add the keyword CONFIG in your source code file, followed by the desired config bit and its value. You can place the CONFIG keyword anywhere in your source code, but we think it makes sense to place them at the beginning of the program.

The config bit memory is located in a physically separate region to your program code, and so adding these statements into your source code files will not alter your program in anyway; the assembler recognises the CONFIG keyword and simply generates the appropriate values to write into Flash, storing them in the .hex file when your program is built.

To create this month's program, start by creating a new project in MPLAB (we called ours 'test1'. You can refer to the September issue for steps to create a project, or copy the project files from the EPE website.) Fig.4 shows how the basic config settings are written in the source file.

### Clock speed

Having configured the minimal 'useful' config bit settings, we next need to think about what clock speed to run at. For this, we have to refer back to the processor datasheet, DS39974A, section 3. There are a large number of options – adding flexibility at the cost of initial confusion – but with careful reading, re-reading and reference to the clock diagram figure it's possible to work out what the suitable options for use are.

Our minimal config bit settings select the internal RC oscillator, and for simplicity we will stay with this setting. This oscillator runs at 8MHz, giving us an instruction execution rate of up to two million instructions per second – quite fast enough for starters!

Although the RC oscillator is not going to be as accurate as an external crystal oscillator, it has been calibrated during chip manufacture, and with the on-chip voltage regulator it is surprisingly accurate – typically ±0.25%, worse case ±1%. This is well within the accuracy required for RS232 serial communication (a typical timing-sensitive requirement for microcontroller circuits) and will be accurate enough for many needs. If you need better accuracy, for example to maintain a



```

C:\transfer\EPE-FIG04DX\MAR-2013\src\test1\test1.asm
; delay for a number of seconds
; value in W register defines how many seconds
delay_s
movwf delay_ls

da1:
btf INTC0N, TMR0IF
movwf HIGH_TMR0_COUNT_LS
movwf TMR0N
movwf LOW_TMR0_COUNT_LS
movwf TMR0G
movwf TMR0_CONF
movwf TMR0CN / Start the timer

da0:
btfsc INTC0N, TMR0IF ; Wait for the ls period to occur
goto da0

deafsa delay_ls
bza da1 ; loop for the number of seconds requested
clrf TMR0CN ; Disable timer
retlw 0
end

```

Fig.4 (left). The delay subroutine

Fig.5 (below). Config bit settings and main application

```

C:\transfer\EPE-FIG04DX\MAR-2013\src\test1\test1.asm
include <P1827J13.INC>

CONFIG MCHEN = OFF
CONFIG XINST = OFF
CONFIG DECO = OFF
CONFIG FOSC = OFF
CONFIG OSC = INTOSC
CONFIG DEMCON = OFF

; RAM addresses of variables
delay_ls EQU 0x00

; Constants
TMR0_COUNT_LS EQU 0x820 ; TMR0 count start value for a ls period
TMR0_CONF EQU 0x84 ; timer is 16bit, FOSC/4 source, prescale by 32
TMR0_LS_TIME EQU 10 ; time between toggling the LED = 10s

; Set the code address to start of flash -
; this is where the processor will start
; executing instructions from after a reset.
org 0

movlw 0x00
movwf TRISB ; Set PORTB as an output
movlw 0x70
movwf CS0CON ; Set processor to run at 8MHz

loop:
comf LATA ; toggle all bits in PORTA
movlw TMR0_LS_TIME
call delay_s ; delay for 10 seconds
goto loop

```

## Running the code

As can be seen in Fig.2, we have connected the Pickit 3 to the breadboard using a right-angled five-pin header strip and then hooked the power, MCLR, PGD and PGC pins across. If you don't have a header strip to hand, you can simply push hookup wires directly into the Pickit's socket.

Although this will work, it may damage the socket over time. The Pickit is quite a robust piece of electronics and should last many years, so it's worth avoiding unnecessary wear on the socket by using a header strip like we have.

To run the program on the breadboard load the program into MPLAB and attach the Pickit 3 programmer to the PC. Wait a few seconds to allow Windows to detect the programmer and then click on **Debugger->Select Tool** from MPLAB's main menu, and click on Pickit 3. (Note that you do not need to power the breadboard; the Pickit 3 can supply enough power to processor.)

In the Output dialog box of MPLAB you should see a series of messages confirming the Pickit 3 has been found, and then finally the statement 'Device ID Revision = 00000001' confirming the detection of the processor.

If this message does not appear and you get a PK3Err message instead, it's likely MPLAB has not been configured to apply power to the board. Select the Debugger->Settings option in MPLAB, click on the Power tab and set the voltage to 3.25V and tick the 'Power target' option.

To start the program running, click Debugger->Run.

There is something quite satisfying about seeing such a simple bit of functionality running for the first time. In a purely electronic design this would be trivial, but in a microprocessor circuit it marks the mastery of a great deal of initial complexity, and from this point things start to get simpler.

Except in this case, where we are going to set up the processor Interrupt System....

Even a trivial program like this has drawbacks, and is crying out for a design using interrupts. Why? Two reasons: expandability and power consumption. We will come back to power consumption next month, but let's take a look at why the current design (no pun intended!) is poor.

## Drawbacks

The drawback with this design is that your main processing 'loop', the place where you would add your project's functionality, has a fixed delay within it. Let's say you want to read a temperature sensor and send the reading over the serial port – the fastest you can do that is once every 10s, because of the call to 'delay\_s' inside the loop. A delay present only to enable us to flash an indicator LED!

It is possible to jiggle around with the design – perhaps change the delay routine to say 100ms, and then increment a counter each time you go round the loop, toggling the LED once every

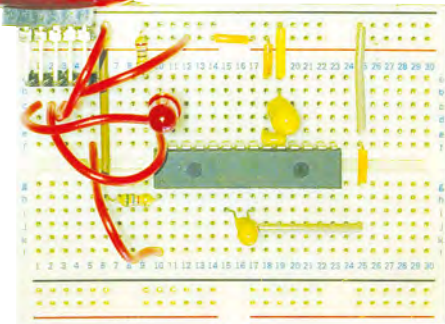

Fig.3. Breadboard Layout

real-time clock, then you can add an external crystal later on. We will be covering use of real-time clocks later in the series.

The internal clock can also be multiplied up via the magic of a phase-locked loop circuit within the processor, to give a clock rate of 48MHz – all just by changing the configuration bits. We will cover running at such dizzying speeds next month. Running the processor at such a high speed can introduce problems due to timing and current consumption, so we will keep things simple at first.

Let's creep up on the subject of interrupts by creating a simple application to prove our hardware is working, have created a project in MPLAB correctly and have the oscillator running at the frequency we believe it should. In microprocessor circuits, a typical initial program is to flash an LED at a defined rate, and we will follow that principle.

## Program design

Our application will configure PORTB as output pins, and then enter a loop that toggles the port pins every 10 seconds. To provide some flexibility, we will create a delay subroutine that will pause for the number of seconds specified in the W register. You will find out next month why such a slow toggle rate was specified.

There are a number of ways to implement a delay routine; you can create a series of loops, one inside the other, that does nothing other than call a few NOP instructions. That is the simplest approach to understand, but painful to create – at a clock speed of 8MHz you will need to execute 2,000,000 instructions to delay for one second. Getting the timing accurate (if you wanted to) is very difficult.

A far better approach is to use one of the several timer peripherals on the processor. Take a look at Timer 0, it's a simple peripheral that increments a register (8-bit or 16-bit) by one on each clock cycle. There are options to 'prescale' (divide the input clock down in frequency) by a factor of between two and 256. When the count register overflows from FFFF to 0000, a bit called TMR0IF is set in another register. We simply load a value into the count register and wait for the TMR0IF flag to be set.

With sixteen bits within the count register, we can count between one and 65535 clock cycles. With that constraint, we have to decide what prescale value to apply to the input clock. There is a simple rule of thumb to do this: choose the highest input clock frequency that will count to 65535 in a time of just over one second.

Given that the input frequency to the timer is 2MHz (FOSC/4,) a prescaler divisor of 32 (62.5kHz) will give a maximum period of 1.049s. That's great, as it's very close to 1s, just 49ms longer. To 'tune' the timer even closer we will load the count register with a starting count value equal to 49ms, which at an input clock of 62.5kHz is 3062 (62500 × 0.049)

So all we need to do is set the Timer0 input clock source to FOSC/4, configure the prescaler to 32, clear the TMR0IF flag, load the count register with 3062, turn on the timer and wait for the flag to be set. The code is very short, and can be seen in Fig.4.

The completed program is shown in Fig.4 and Fig.5. Don't forget that the full source files can be downloaded from the EPE website if you would like to try this code out yourself, or use it as the basis for your own project.

100 times you go round. This adds complexity to the main loop, doesn't 'look' good, and more importantly will cause the rate at which the LED toggles to be dependant not only on your delay routine, but by how long your application code takes to run. And there is still a fixed 100ms delay in your loop. This is not good.

What we want is a way for the code that toggles the LED to run *independently* of the main application loop. Almost as though it were running on a different processor.

This is where interrupts come to our aid.

## Interrupts

An interrupt is a signal that comes into the CPU – either from an external pin or one of the hardware peripherals – that causes the CPU to stop executing the program it is running and jump off to a different subroutine. When that subroutine finishes, it will return back to the original program at the point where it left off. That's all the processor does; it's our job as programmers to decide what the subroutine will actually do in response to that interrupt, and to make sure that whatever code is run, it doesn't interfere with the operation of the main program.

That view of interrupt handling is rather simplistic. First, there are many different possible sources of interrupts, each of which may (or may not) have its own unique subroutine start address. Then, we have to work out how to enable an interrupt, clean up after processing the interrupt and then return back to our original program. Add to this the fact that different processor types handle these aspects in different ways and you have a recipe for confusion!

## Interrupt priorities

On a 'high end' processor, such as the PIC18F, there is an option to enable high and low interrupt priorities. This allows one interrupt routine (the higher priority one) to interrupt a lower priority interrupt routine already running.

This is a very advanced feature that can trip up the hobbyist and experienced software engineers alike, and is best avoided. By default, this feature is disabled, and we will not cover it at this stage.

## Interrupt handling

Virtually all peripheral features on the processor can generate an interrupt – 43 different sources in total on the PIC18F27J13. To enable an interrupt you set the appropriate Interrupt Enable flag, and the global Interrupt Enable flag GIE.

GIE is like an additional on/off switch for all interrupts; it comes in handy to temporarily disable any interrupt from occurring, which might be necessary in your code if you have a sequence of instructions that must not be interrupted (what engineers call a 'critical section'). Excessive use

of the GIE in this way is considered bad programming practice, but there are times when it comes in handy.

For some peripheral interrupt sources there is an additional Interrupt Enable bit, PEIE, that must be set to enable those sources. Quite why it is present is something of a mystery, but it's a flag that you can set and then forget about.

The processor requires that the interrupt routine be located (or at least, the first instruction must be located) at address 0x0008 in Flash memory. The interrupt routine can use any data memory or special function registers, but when an interrupt is triggered, you, as the programmer, are responsible for not only avoiding writing to variables used by your main application, but also saving the values of the main CPU registers WREG, STATUS and BSR. Obviously, as your main application could be interrupted *at any point*, failing to preserve these registers will quickly cause your program to crash.

When the interrupt is detected and the program jumps to your interrupt routine, the CPU automatically copies these three registers to special function registers called the *Fast Return Stack*. To restore them automatically at the end of your interrupt routine, you must use the assembly instruction:

```
RETFIE FAST
```

Failing to do so (ie, using RETLW or just RETFIE) will cause your program to crash.

The final point to consider is that the interrupt routine **must** clear the particular Interrupt Flag bit that generated the interrupt prior to leaving the interrupt routine. Failing to do so will result in the interrupt routine being called again immediately, forever, causing your main application to halt.

There is a golden rule associated with interrupt subroutines: An interrupt should be quick, and do as little as possible. The whole idea behind interrupt routines is to quickly respond to time-critical events, capture key information and store them for the main application to pick up at a later point when it is ready.

So, a UART serial communication receive interrupt routine, for example, will just extract the received byte from the receive register and place it into a buffer. The main application can pick it up later, and may find one or several bytes in the buffer. Avoid doing any time-consuming processing in an interrupt. If you execute more than 30 instructions in an interrupt routine, it's probably worth thinking about redesigning your application.

## A better test program

So, having introduced the concept of interrupts, let's take a look at our simple test program and see what we can do.

By coincidence, we are already using part of the interrupt system –

```

org 0
goto main

; Interrupt routine entry address - always 0x0008
org 8
btf INTCON, TMR0IF

; only toggle the LED after 10 interrupts
decfsz delay_is
goto int_exit

comf LATB ; toggle all bits in PORTB

; reset the 10s counter
movlw TOGGLE_LED_TIME
movwf delay_is

int_exit:
retfie FAST

main:
movlw 0x00
movwf TRISB ; Set PORTB as an output
movlw 0x7f
movwf OSCCON ; Set processor to run at 8MHz

movlw TOGGLE_LED_TIME
movwf delay_is

btf INTCON, TMR0IF
movlw HIGH TMR0_COUNT_IS
movwf TMR0H
movlw LOW TMR0_COUNT_IS
movwf TMR0L
movlw TMR0E
movwf TMR0E
movlw TMR0_CNTR
movwf TMR0CNTR ; Start the timer

loop:
goto loop

```

Fig.6. Final test application

when TMR0 reaches the target count value of FFFFh and then counts over to 0000h, the interrupt flag TMR0IF is set, which we are waiting for in the loop in our delay routine. Just because the Interrupt Enable bit is not set does not mean that the interrupt flag will not be set by the peripheral – and this is very useful in these circumstances, where we want to detect events occurring without using interrupts.

The revised program is shown in Fig.5. The initialisation code in the main application has been expanded to include enabling the TMR0 interrupt bit, and setting the GIE flag. Notice that our 'main application' is now an empty loop – toggling of the LED is handled completely within the interrupt routine. This routine, much like the delay routine within the original, simply counts the interrupts, which will happen at a rate of one a second, and toggles the pins on PORTB when the count reaches ten.

It's important to remember here that as a general rule, *any* registers written to within the interrupt – the count variable and LATB – cannot be written to by the main application. As your interrupt routines become more complicated there will be exceptions to this rule, and we will discuss those next month.

The completed MPLAB project for this second test application can also be found on the *EPE* website.

## Next month

Next month, we stay with this test program to look at a very important use of interrupts – reducing power consumption. For projects powered via mains adaptors this is not really an important factor where PIC processor designs are concerned, but for battery-powered projects it is absolutely critical. The PIC processor has several low-power modes, and interrupts are key to making use of them.

# PIC Training Course

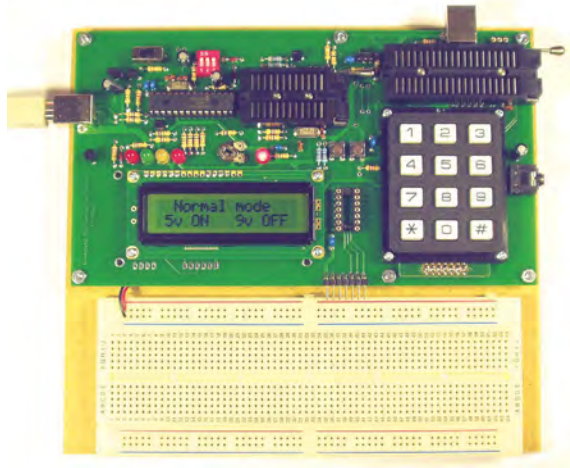

## P931 Course £148

Imagine trying to teach English grammar to a child before allowing him or her to speak!. Yet that is how most books approach a technical subject. We know better. We know that practical experience makes learning the theory an interesting proposition. The success has been proven with time. We have been selling PIC training courses for so long we are recommended by Dick Turpin. Richard has been our customer since 2002 and regularly updates. He recently bought our Easy USB and PICs and Power add ons.

We started in 2000 using the PIC16F84, updated in 2007 to the PIC16F627A, and updated in 2010 to the eXtremely Low Power PIC16F1827. The course follows the same well proven structure with two real books which lie open on your desk while you use your computer to type in the programme and control the hardware. Start with four simple programmes. Run the simulator to see how they work. Test them with real hardware. Follow on with a little theory.....

Our PIC training course consists of our PIC programmer, a 320 page book teaching the fundamentals of PIC programming, a 306 page book introducing the C language, and a suite of programmes to run on a PC. Two ZIF sockets allow most 8, 18, 28 and 40 pin PICs to be programmed. The programming is performed at 5 volts then verified at 5 volts and 2 volts or 3 volts.

P931 PIC Training & Development Course comprising.....

USB powered 16F and 18F PIC programmer module

- + Book Experimenting with PIC Microcontrollers
- + Book Experimenting with PIC C 6th Edition
- + PIC assembler and C compiler software on CD
- + PIC16F1827, PIC16F1936 & PIC18F2321 test PICs
- + USB cable. . . . . £148.00

(Postage & insurance UK £10, Europe £20, Rest of world £30)

## Experimenting with PIC Microcontrollers

This book introduces PIC programming by jumping straight in with four easy experiments. The first is explained over seven pages assuming no starting knowledge of PICs. Then having gained some experience we study the basic principles of PIC programming, learn about the 8 bit timer, how to drive the liquid crystal display, create a real time clock, experiment with the watchdog timer, sleep mode, beeps and music, including a rendition of Beethoven's *Fur Elise*. Then there are two projects to work through, using a PIC as a sinewave generator, and monitoring the power taken by domestic appliances. Then we adapt the experiments to use the PIC18F2321. In the space of 24 experiments, two projects and 56 exercises we work through from absolute beginner to experienced engineer level using the very latest PICs.

## Experimenting with PIC C

The second book starts with an easy to understand explanation of how to write simple PIC programmes in C. Then we begin with four easy experiments to learn about loops. We use the 8/16 bit timers, write text and variables to the LCD, use the keypad, produce a siren sound, a freezer thaw warning device, measure temperatures, drive white LEDs, control motors, switch mains voltages, and experiment with serial communication.

Web site:- [www.brunningsoftware.co.uk](http://www.brunningsoftware.co.uk)

## Serial Coms Extension £31

This third stage of our PIC training course starts with simple experiments using 18F PICs. We use the PIC to flash LEDs and to write text to the LCD. Then we begin our study of PC programming by using Visual C# to create simple self contained PC programmes. When we have a basic understanding of PC programming we experiment with simple PC to PIC serial communication. We use the PC to control how the PIC lights the LEDs then send text messages both ways. We use Visual C# to experiment with using the PC to display sinewaves from simple mathematics. Then we expand our PC and PIC programmes gradually until a full digital storage oscilloscope is created. For all these experiments we use the programmer as our test bed. When we need the serial link to the PC we flip the red switches to put the control PIC into its USB to USART mode.

In the second part of *Experimenting with Serial Communications* 4th Edition we repeat some of the serial experiments but this time we use a PIC18F2450 with its own USB port which we connect directly to a USB port of your PC. We follow this with essential background study then work through a complete project to use a PIC to measure temperatures, send the raw data to the PC, and use the PC to calculate and display the temperature.

290 page book + PIC18F2450 test PIC +USB lead..... £31

## P942 Course £173

This has the same books and features as the P931 course. The P942 programmer/development module can be powered from a separate PSU (programming verified at 5.5 volts, 5 volts and 2 or 3 volts) or powered from USB (programming verified at 5 volts and 2 volts or 3 volts). The P942 can programme 3.3 volt as well as 5 volt 16F and 18F PICs, and has an RS232 port as well as the USB port for experimental use. See website for details.

## Ordering Information

Our P931 & P942 programmers connect directly to any USB port on your PC. All software referred to operates correctly within Windows XP, NT, 2000, Vista, 7, and Windows 8 etc. telephone for a chat to help make your choice then go to our website to place your order (Google Checkout or PayPal), or send cheque/PO, or request bank details for direct transfer. All prices include VAT if applicable

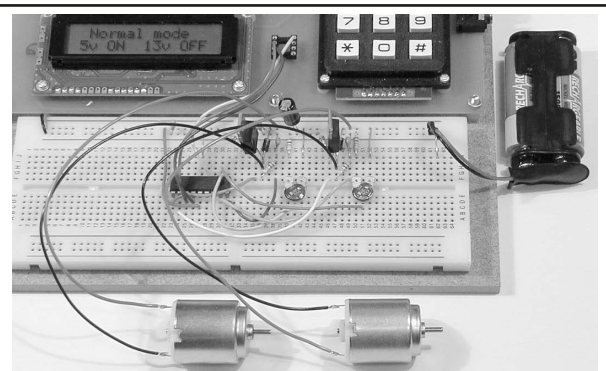

## White LED and Motors

Our PIC training system uses a very practical approach. Towards the end of the PIC C book circuits need to be built on the plugboard. The 5 volt supply which is already wired to the plugboard has a current limit setting which ensures that even the most severe wiring errors will not be a fire hazard and are very unlikely to damage PICs or other ICs.

We use a PIC16F1827 as a freezer thaw monitor, as a step up switching regulator to drive 3 ultra bright white LEDs, and to control the speed of a DC motor with maximum torque still available. A kit of parts can be purchased (£31) to build the circuits using the white LEDs and the two motors. See our web site for details.

Mail order address:

# Brunning Software

138 The Street, Little Clacton, Clacton-on-sea,  
Essex, CO16 9LS. Tel 01255 862308



# Max's Cool Beans

By Max The Magnificent

Wow! Things have been quite exciting here in the pleasure dome (my office) recently, not the least that I ended up pledging \$99 to a Kickstarter project. Are you familiar with [kickstarter.com](http://kickstarter.com)? If not, I bet you'll be hearing a lot about them soon. The idea is that if you need to find funds for a creative project – anything from films, games, and music, to art, design, and technology – but you don't want to go through the regular routes (banks, venture capitalists, etc.), then you can use Kickstarter to 'crowd source' your project.

So how did it come to pass that I made a pledge on Kickstarter? And which project did I support? Ah, therein lies a tale...

## Garage mentality

Technology folklore is replete with stories of companies that started life out of a garage. Two companies that spring to mind are Apple Computers and Hewlett Packard. Generally speaking, however, when it comes to designing something like a silicon chip, just about everyone I know would say that this would only be possible if one had a large design team of extremely experienced engineers. Furthermore, most people I know would say that the task of actually building such a chip would require a budget of at least one million dollars.

So, you can imagine my surprise when I was introduced to a guy called Andreas Olofsson a couple of years ago, because Andreas had just designed and built his own silicon chip. A few years prior to our meeting, Andreas came to the conclusion that existing solutions were not as efficient as one might hope when it came to the number of floating-point operations (flops) that could be achieved per watt. The thing is, we are demanding more and more processing capability, and even battery-powered handheld applications increasingly require the ability to perform computationally-intensive tasks while consuming as little power as possible.

Andreas left his job, disappeared down into his basement, and – sustained by sandwiches made by his wife and living off his pension fund – he designed a new silicon chip from the ground up. Known as the Epiphany, this device comprises an array of processing nodes. Each node includes an extremely efficient floating-point processor, some local memory, and a router to handle inter-node communications.

The first Epiphany was created using a 65nm silicon chip technology and contained 16 processing nodes. The latest version is implemented at the 28nm technology and contains 64 processing nodes. This current device is capable of performing 100 gigaflops (that's 100 billion floating-point operations per second) while consuming only 2W, which is staggeringly efficient.

## \$100 personal supercomputer

A couple of weeks ago, Andreas called me to ask for my help. His current project is to create a personal supercomputer called the Parallella for only \$100. This little beauty is going to be formed from the combination of an Epiphany device with a Zynq All Programmable SoC from Xilinx.

In addition to traditional programmable FPGA fabric, the Zynq boasts a dual-core ARM Cortex-A9 processor along with a host of peripheral and interface functions. The idea is that the Zynq will run Linux and handle all of the user-interface and control functions, while the Epiphany will do the 'heavy lifting' when it comes to compute-intensive digital signal processing tasks.

The end result will be like a Raspberry Pi on steroids. This open source platform will be able to implement the most computer-intensive tasks, like embedded and robotic vision, software-defined radios, and ... well, almost anything really.

The reason for Andreas' call was that he and his colleagues had launched a Kickstarter project to raise \$750,000. When we talked, they had only raised around \$430,000 and they had only five days to go before the Kickstarter deadline expired. Well, the thought of having my own personal supercomputer was too much to resist, so I immediately pledged \$99, for which I will receive one of the first Parallellas to roll off the production line.

Now, in addition to my *Cool Beans* column for *EPE*, I'm also the Editor in Chief for *All Programmable Planet* ([www.AllProgrammablePlanet.com](http://www.AllProgrammablePlanet.com)), plus I sort of know a lot of people, which is one of the benefits of having been around for a long time. So I started posting blogs online and emailing my contacts asking them to spread the word.

I have to say that it was all rather exciting really. The deadline was 6:00pm on the Saturday. By the time the Kickstarter project automatically shut down, the total pledge amount was \$898,921 – almost \$150,000 over the original target!

The only problem from my perspective is that now I've discovered [kickstarter.com](http://kickstarter.com), I keep on bouncing over there to see what new projects have been launched.

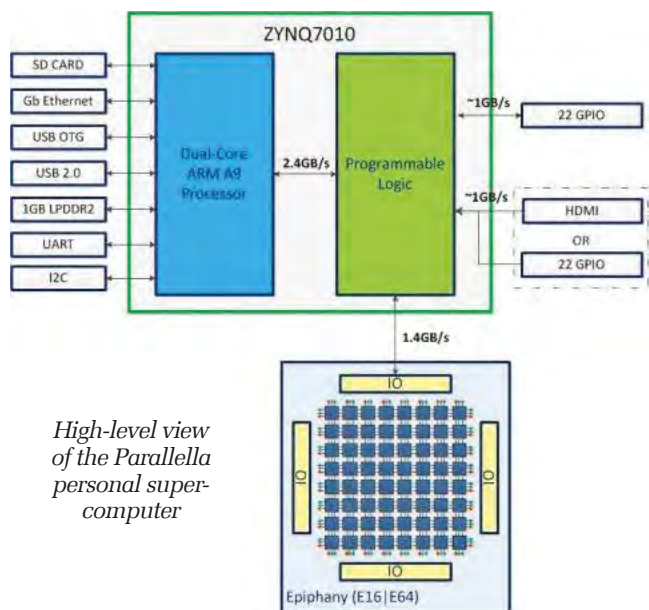

High-level view of the Parallella personal supercomputer

# Raspberry Pi

## Keypad and LCD interface

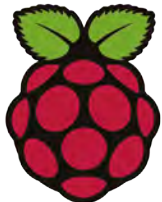

Time for some Pi  
By  
Mike Hibbett



**WE** present another construction project for the Raspberry Pi this month – getting a little more interactive with the hardware – producing a simple keypad and LCD display.

What has become apparent during the development of this month's article is that writing software on the Pi, while possible, is not a particularly pleasant experience. The slow speed of the processor, limited memory and serial flash memory storage result in slow responses to keypresses and mouse clicks.

Over the course of a few hours this can become very tiring, but fortunately there are other ways to write software in a fast and comfortable manner. We will pick up on those in next month's article. For now, let's dive into this month's project.

### Construction project

It's not always desirable to connect your Pi up to a large expensive HDMI monitor. Composite video output to a small television does work, but doesn't look great – even slight blurring can be tiring on the eyes. While the issue of poor video output on smaller TVs is a drawback, it's a non-issue if the Pi will be used in a remote location and communicating via a serial or network connection. The Pi is quite happy to operate without a display, mouse or keyboard connected.

Some projects, however, do call for a display and keyboard, but when the device is battery powered, space constrained or in an environmentally harsh location we need an alternative to a large, power hungry monitor. A display, such as our old 'friends', the trusted 2 × 16 character LCD and a keypad spring to mind, and so this month we will look at designing the hardware and software to make it happen.

The Raspberry Pi printed circuit board (PCB)

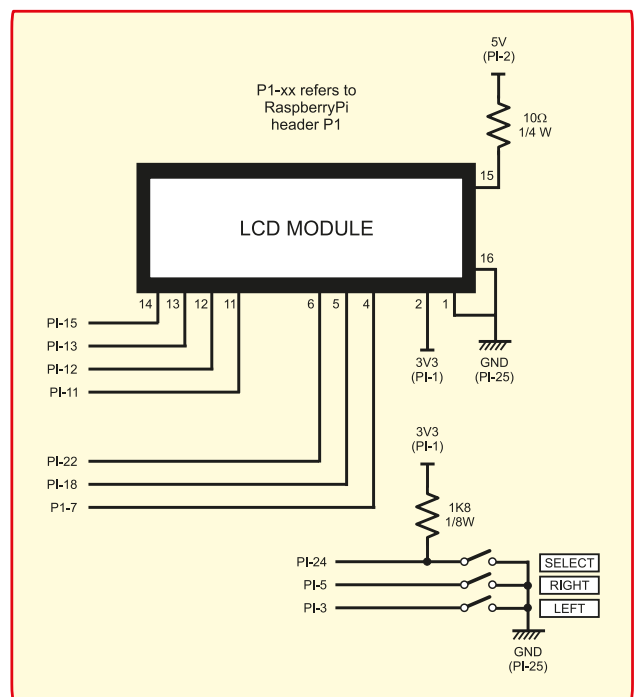
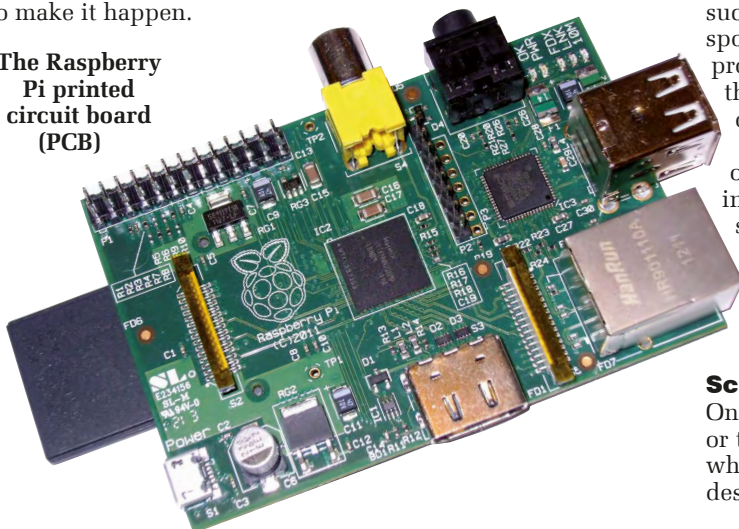

Fig.1. Circuit Diagram

### Programming language

We will write the driver software for the hardware as standalone utilities (one for the display, one for the keypad) that you can use with your own projects. With such a powerful microprocessor platform we are somewhat spoiled for choice in how to develop the software for these programs. The most obvious ones are Python and C, and this month we have chosen to continue to use C – for no other reason than familiarity.

The software presented here may be copied into your own C programs or run as standalone programs that you invoke from a script file. Building applications through scripting is a standard development technique on Linux computers, but as it is likely to be an unfamiliar concept for hobbyists used to small embedded systems we will take the opportunity to explore this further, starting this month.

### Scripting

On Linux-based systems – whether powerful computers or tiny embedded systems – scripting refers to the way in which small programs are chained together to achieve a desired action. The output of one program is fed to the

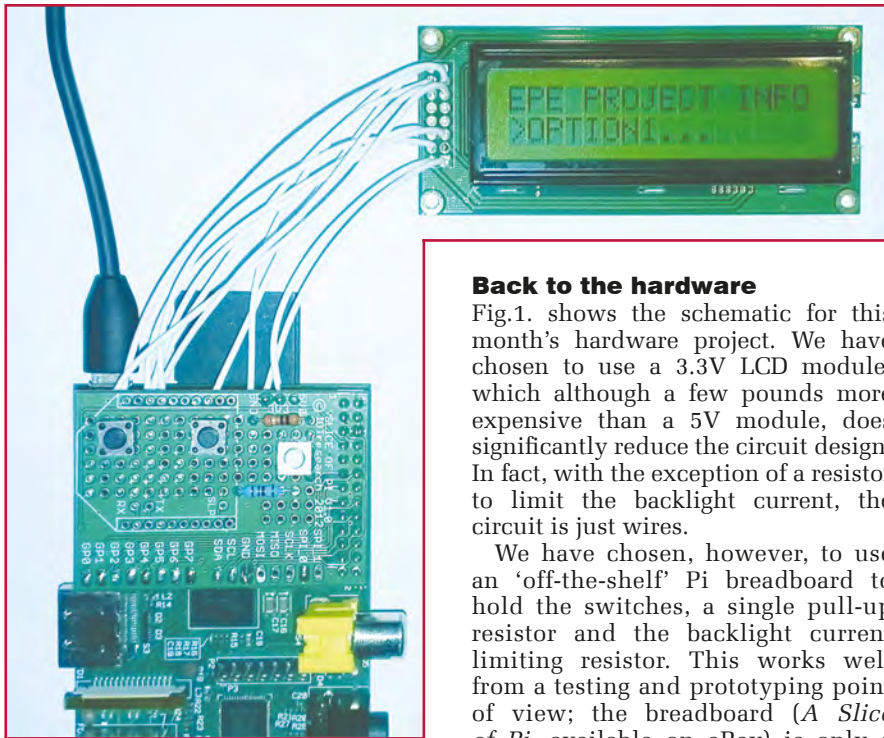

Fig.2. Wired up on prototyping PCB

input of another, and conditional statements can determine if one action is taken rather than another in a similar way to how DOS batch files work.

You write a text file called a 'script' to specify the programs that you want to run, where they take their input, and what they should do with their output. Script files are run in a 'shell' – the Linux equivalent of a DOS command prompt. The shell is a program that can be interactive or run automatically on startup (typically from another script). When you log into the Pi on power up and type 'startx', you are communicating interactively with a shell.

The shell program is a powerful programming language interpreter, far more powerful than the old DOS prompt. There are a number of different shell programs that have been developed over the years, offering additional features or a slightly different command language, and in the case of the Pi, the **bash shell** is used.

The shell is providing, in effect, a programming language. 'Oh no' we hear you say: 'Not another programming language to learn!' Despair not – scripting languages are designed to enable you to tie together other applications, and really only provide the 'glue logic'. We'll give an example later that should make this clear.

It's a bit of a mind-set change too, for those of us used to writing a single application that provides all the functionality required. As systems like the Pi are designed to run with the Linux operating system, we might as well go through the effort of learning how to make full use of scripting, because the facility is there, whether we want it or not.

### Back to the hardware

Fig.1. shows the schematic for this month's hardware project. We have chosen to use a 3.3V LCD module, which although a few pounds more expensive than a 5V module, does significantly reduce the circuit design. In fact, with the exception of a resistor to limit the backlight current, the circuit is just wires.

We have chosen, however, to use an 'off-the-shelf' Pi breadboard to hold the switches, a single pull-up resistor and the backlight current limiting resistor. This works well from a testing and prototyping point of view; the breadboard (*A Slice of Pi*, available on eBay) is only a few pounds and provides a strong mechanical base. You can see the assembled board in Fig.2. Only a single pull-up resistor is required as the 'LEFT' and 'RIGHT' buttons are connected to Pi I/O pins that already have pull-up resistors fitted, due to the pins being designed to be used for an I<sup>2</sup>C interface. If you decide to use different I/O pins for these buttons you should add pull-up resistors to the line 3V3.

The LCD uses the industry standard 44780 drive interface with a 4-bit data bus, an enable line, R/W line and register select line, giving seven output pins in total. With three IO pins used for buttons, there are seven IO pins remaining for other uses.

### Software approach

The software development approach is identical to the RTC (real-time clock) module we covered in the previous article, and, in fact, we re-used most of the initialisation code. We had to work out the mapping of the processor GPIO port pin numbers from the Pi schematic, and determine the processor register locations from the Broadcom datasheet.

As the buttons and LCD module are not connected in any way, we have chosen to create two separate utilities. There is some duplication of code when doing this, but the applications are quite small once compiled. This simplifies the applications command line options, which we have chosen to be like this:

#### lcd-pi -i

Initialise the display; should be called once before displaying text.

#### lcd-pi -t "text"

The text is written to the display from the top left corner of the display.

#### lcd-pi -12 -c 10 -t "text"

The text is written to the display from the line and column specified.

For the buttons, the program is invoked like this:

#### btn-pi -t

Test whether a key is currently pressed, returning a numeric value of 0 if none, or 1 if a key is pressed.

#### btn-pi

Waits until a key is pressed and then returns a numeric value indicating the key that is pressed: 1 for LEFT, 2 for RIGHT or 3 for SELECT.

### Development

The button application is trivial; once the normal setup of the GPIO pins as inputs has been done, it is a simple case of monitoring the pins to catch them when they go low in response to a button being pressed. We have added a short delay on exit from the program to provide a small amount of debounce; in use, you will probably want to add your own delay (using the sleep utility) following a keypress to suit your needs.

In the LCD module application we have taken a very simple approach to the implementation, using bit-bashing for each of the seven IO lines driving the display. This significantly simplifies the code changes required if you decide to change the Pi port pins that drive the display.

The more interesting software issue is how to use these two utilities to create your application. The syntax for 'bash' script files is complex (you can buy books on the subject) but a good starting point is one of the main tutorials freely available on the web. One such tutorial can be found at <http://freeos.com/guides/lst/>.

By way of an example, Listing 1 shows the test program we used to exercise both utilities.

To create this script, right-click on the desktop, select 'New', followed by 'Blank File'. Enter the name for the file, **test.sh**

### Listing 1: Test script

```
sudo ./lcd-pi -i

for ( ( ;; )
do
  sudo ./btn-pi
  return_val=$?

  if [ $return_val -eq 1 ]; then
    sudo ./lcd-pi -t "LEFT pressed"
  fi
  if [ $return_val -eq 2 ]; then
    sudo ./lcd-pi -t "RIGHT pressed"
  fi
  if [ $return_val -eq 3 ]; then
    sudo ./lcd-pi -t "SELECT pressed"
  fi

  sleep 1s
done
```



This will create the file and place it on the desktop. To edit it, right-click over the file and select Leafpad. Type in the text shown in Listing 1.

At this point, the file is a simple text file, but we want it to be executable. To make it so requires that we change the permissions on the file. To do this, open a shell prompt. Click on the start button, followed by Accessories->LXTerminal. Change directory to the Desktop by typing:

```
cd Desktop
```

then change the file to executable by entering the command:

```
chmod +x test.sh
```

Finally, run it (assuming you have copied the utility programs to the desktop already) by entering the command:

```
./test.sh
```

The LCD module's display should clear. Pressing one of the three buttons should show the button name on the display.

To exit, press ctrl-Z.

The source code files for the two utilities and the test script file can be found on the *EPE* website as usual.

To build them, open up an LXTerminal command prompt and change to the Desktop directory (where we assume you copied the files to).

Run the commands:

```
cc lcd-pi.c
mv a.out lcd-pi
chmod +x lcd-pi
```

```
cc btn-pi.c
mv a.out btn-pi
chmod +x btn-pi
```

#### Please take note

In our previous article, published in the Sept '12 issue, there is an error in the circuit diagram of the *Real Time Clock* project. The connections GP17 and GP21 are transposed. Pin 5 (CE) should go to GP17 and pin 7 should go to GP21. The photograph of the layout is correct.

Our thanks to reader Les Jones for pointing this out.

#### Next month

Next month, we take a look at some of the improvements that have been made in the operating system used by the Pi, and cover the problems that have been found in the original hardware release. We also investigate different software development approaches, taking advantage of the network capabilities of the Pi. Plus, we look at how to automate your script-based applications to start on power-up.

Until then, happy scripting!



**Laser**  *Why tolerate when you can automate?*

 <b>X-10</b> Home Automation	 <b>C-Bus Shop</b> C-Bus and C-Bus Wireless
 <b>KATS</b> AV transmission and IR control system	<a href="http://www.cbushop.com">www.cbushop.com</a>
 <b>Barix</b> Ethernet based MP3, communications and control systems	<a href="http://www.laser.com">www.laser.com</a>

[www.laser.com](http://www.laser.com)

*Integrators, Installers, Trade  
and Retail customers welcome*

Laser Business Systems Ltd  
Tel: +44 (0) 20 8441 9788  
Fax: +44 (0) 20 8449 0430  
Email: [info@laser.com](mailto:info@laser.com)  
16 Garthland Drive, EN5 3BB

**TO ADVERTISE IN  
EVERYDAY PRACTICAL  
ELECTRONICS  
PLEASE CONTACT  
Stewart Kearn on  
01202 880299  
or email  
[stewart.kearn@wimborne.co.uk](mailto:stewart.kearn@wimborne.co.uk)**

Use Tandy Components To Bring Your Ideas To Life!



[www.tandyonline.co.uk](http://www.tandyonline.co.uk)



**Standard UK Delivery Just £1 ! - Any Order Any Size**

## More notes on the Early effect

**F**OR the last couple of months, we have been looking at the Early effect in bipolar transistors in response to a question from chatzone user *lost*.

*Is the Early effect, which gives rise to  $h_{re}$  ( $dV_{be}/dV_{ce}$ ), related to the Early voltage which gives rise to  $h_{oe}$  ( $dI_c/dV_{ce}$ )?*

The first article described the Early effect in terms of the semiconductor physics of the transistor, and the second article looked at how we model these effects in a way which can be used in circuit analysis, design and simulation calculations. The parameters  $h_{re}$  (reverse gain) and  $h_{oe}$  (output conductance), to which *lost* refers, are from one such transistor model (see Fig.1) – the  $h$ -parameter model for common-emitter configuration.

An example of what is known as an equivalent circuit model is shown in Fig.1. The transistor's behaviour is represented by the circuit containing basic components, such as voltage sources and resistors with appropriate values of mathematical interrelations.

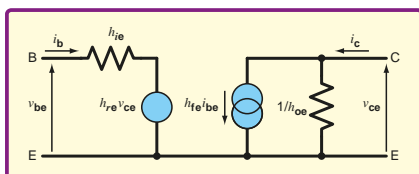

Fig.1.  $h$ -parameter model of the bipolar transistor in common-emitter configuration

The two articles so far have answered *lost*'s question by relating the physics to the model and showing that values of  $h_{re}$  and  $h_{oe}$  are indeed both influenced by Early effect physics. The Early voltage is not a cause of  $h_{oe}$ , or a different phenomenon, as perhaps implied by the question, but is another model parameter which can be used to quantify the strength of the Early effect for a given transistor, and is, as correctly implied by the question, closely related to  $h_{oe}$ .

### Early impact

This month, we will continue with this topic to show how we can use the  $h$ -parameter model to analyse a circuit and hence work out the impact of the Early effect on its performance.

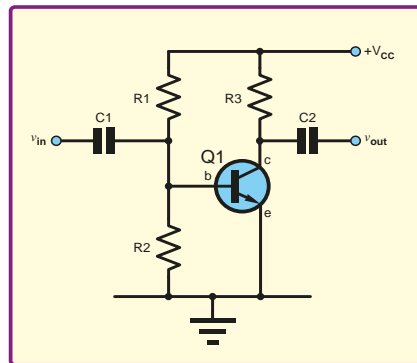

Fig.2. Common-emitter transistor amplifier

### Keeping it simple

We will design and analyse the circuit shown in Fig.2, which is a basic single-transistor common-emitter amplifier with input and output signal coupling capacitors of value  $2\mu\text{F}$ . We will use a supply voltage of  $12\text{V}$ , assume we are interested in low frequency signals (say around  $10\text{kHz}$ ), and also assume that the input signal comes from a source with a very low output impedance. The design process involves choosing suitable component values. Analysis of the circuit allows us to calculate values such as gain and output impedance.

We will keep things as simple as possible by using generic transistor parameters, rather than trying to work with a specific device and by ignoring some aspects of the circuit which do not relate strongly to the impact of the Early effect. The implications of various simplifications will be explained as we go along.

The idea of keeping things simple in an analysis is important one. It prevents us from getting bogged down in excessive detail, often helping to provide important insights, and in some cases makes a calculation feasible, where otherwise it would not be. However, it is important to be aware of the impact of any simplifications, if we ignore important details we can get things very wrong.

It is also important to point out that our aim here is not to design a good amplifier; it is to illustrate the process of analysis which allows us to see the impact of the Early effect on the circuit. For this reason, we won't use preferred values for resistors.

### $h$ -parameter model

The  $h$ -parameter model to which *lost* refers is itself a very important example

of this simplification process in circuit analysis. As we discussed last month, it is what is referred to as a 'small signal' model.

To recap from last month, when dealing with AC signals it is easier to use models in which all the equations are linear. A linear equation, as the name suggests, produces a straight line on a graph when you plot it. Fundamental diode and transistor equations are not linear, but if we take just a small section of their voltage-current characteristic curves, then we get a reasonable approximation to a straight line.

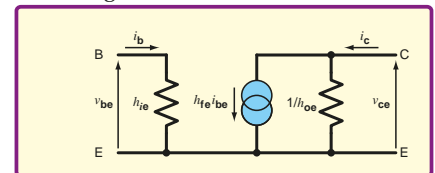

Fig.3. Simplified  $h$ -parameter model

This relates directly to how we design transistor circuits such as amplifiers – we set a bias point (or operating point) which determines the circuit's voltages and currents with no signal present. The signal causes a small variation about this point. We can use the full non-linear model to calculate the bias point and then use the linear model to calculate things such as the gain of the circuit.

For the purposes of this discussion we further simplify the  $h$ -parameter model by assuming  $h_{re}$  is zero. This leads to the equivalent circuit shown in Fig.3. Although  $h_{re}$  is related to the Early effect, its influence will be very small in the circuit we are considering, far less significant than  $h_{oe}$ . In this model, we will use the following parameter values for transistor Q1:

- Forward current gain  $h_{fe} = 100$
- Input resistance  $h_{ie} = 2.5\text{k}\Omega$
- Output conductance  $h_{oe} = 10\mu\text{S}$   
( $1/h_{oe} = 100\text{k}\Omega$ )

### Design and analysis

We can now proceed with the design and analysis of the circuit. As the supply voltage has already been defined, one of the first design decisions is to choose the bias current at which the transistor is going to operate.

There are a few things which might influence this. For example, there may be constraints on supply current and power consumption which set

an upper limit. However, running the transistor at very low currents is likely to give poor performance.

To help make this decision, we can consult the transistor's datasheet where we will, hopefully, find graphs that show how its parameters vary with current. A typical example is shown in Fig.4, which is a graph of forward current gain ( $h_{fe}$  in the  $h$ -parameter model) against collector current.

This clearly illustrates the non-linear nature of the transistor over large ranges of current (the gain varies). However, if we have a fixed bias current and the signal only causes a small variation about this point, then we can assume the gain has a fixed value.

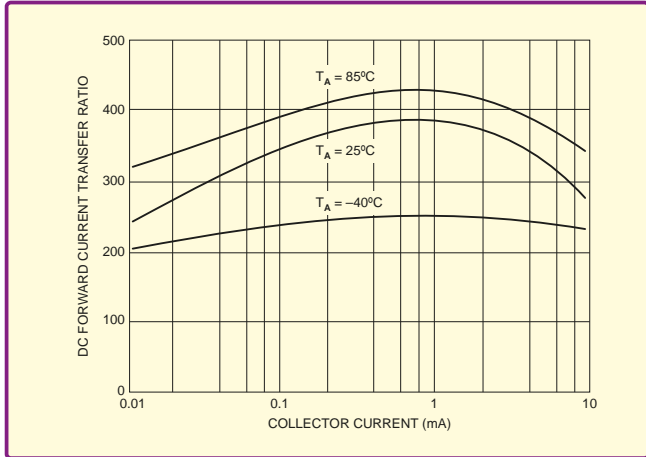

Fig.4. Graph showing example of variation of current gain with collector current and temperature for a transistor

Looking at Fig.4, we might choose something in the range 0.4mA to 1.2mA, because the gain at 25°C is maximum at this point and the curve is reasonably flat (implying smaller changes in gain with current). The graph also clearly shows that the gain is sensitive to temperature.

Last month, we introduced the Shockley ideal diode equation as the basic characteristic equation for a diode. It can be used to calculate the emitter current from the base-emitter voltage (or vice versa), but which does not account for the Early effect, it is:

$$I_E = I_S \left[ \exp\left(\frac{V_{BE}}{V_T}\right) - 1 \right]$$

Noting the  $-1$  is very small compared with the exponential term under normal operating conditions, so it can be removed, we can rearrange this equation to find the  $V_{BE}$  required for a given emitter current:

$$V_{BE} = V_T \ln\left(\frac{I_E}{I_S}\right)$$

As we saw last month,  $V_T$  is called the thermal voltage and is about 26mV at room temperature (actually 300K, about 27°C). Also, assume we know the transistor's reverse saturation current,  $I_S$ , is  $3 \times 10^{-15}$ A. We are not basing our calculations of Fig.3, but assume we

want a bias current of 1mA (emitter and collector currents, these being approximately equal). The equation indicates we need to set  $V_{BE}$  to 0.69V.

Last month, we saw that the Early effect changes the emitter current from the ideal value given above in accordance with the following equation:

$$I_E = I_S \left[ \exp\left(\frac{V_{BE}}{V_T}\right) - 1 \right] \left( 1 + \frac{V_{CE}}{V_A} \right)$$

For a 12V supply in Fig.2, and assuming we bias the collector at half the supply voltage (for maximum possible signal swing), we can use  $V_{CE} = 6$ V. For a typical Early voltage,  $V_A$ , of

100V this will shift the emitter current up by about 6%. It is worth noting that if we use a 5% resistor for R3, the possible error from ignoring the Early effect will be of a very similar size to that caused by resistor tolerance.

There are much larger uncertainties in the emitter current for this circuit. For example, a 5% increase in  $V_{BE}$  (commensurate with resistor tolerance in R1 and R2) causes  $I_E$  to increase from

1mA to around 4mA (using the ideal transistor equation). As  $V_T$  is proportional to temperature, a similar percentage shift in temperature will result in a similar change of emitter current. The circuit in Fig.2 does not have good bias stability. It can be improved by using an emitter resistor, but that is not the focus of the present discussion. We can conclude that the Early effect is not particularly significant when it comes to the biasing of this circuit.

Also, recall from last month that  $V_A$  is approximately related to  $h_{oe}$  as follows:

$$h_{oe} \approx \frac{I_C}{V_A}$$

The values we have:  $h_{oe} = 10\mu S$ ,  $V_A = 100$ V and  $I_C = 1$  mA are consistent with this.

Having decided on a bias current, we can calculate appropriate resistor values. We typically want the collector voltage at about half the supply with no signal, as noted above, so we need:

$$R3 = 6V/1mA = 6k\Omega$$

R1 and R2 form a potential divider which sets  $V_{BE}$ . This needs to carry a current significantly higher than the base current so it is not loaded by the base. The gain of around 100 for the transistor implies 10µA in the base, so something like 100µA should do in the divider. This implies a total resistance of around:

$$R1 + R2 \approx 12V/100\mu A = 120k\Omega$$

Given that R1 is going to be much larger than R2 we can simply use  $R1 = 120k\Omega$ , and then find R2 using a version of the potential divider formula:

$$R2 = \frac{R1 V_{BE}}{(V_{CC} - V_{BE})} = \frac{120k \times 0.69}{(12 - 0.69)} = 7.32k\Omega.$$

### Small signal analysis

Now we have all the component values, we can move on to the small signal analysis using the  $h$ -parameter model. Before starting to draw the model equivalent circuit, it is useful to consider if there are any components we can justifiably omit in order to simplify the analysis. The capacitors are candidates for this.

The coupling capacitors have a value of 2µF. Assuming we are interested in signals of around 10kHz, the impedance of these capacitors is:

$$Z_C = \frac{1}{2\pi f C} = \frac{1}{2 \times \pi \times 10^4 \times 2 \times 10^{-6}} = 7.96\Omega$$

This means the capacitor impedance is much smaller than any of the resistors and the internal resistances of the transistor ( $h_{ie}$  and  $1/h_{oe}$ ). This allows us to make the assumption that capacitors act as short circuits at the frequency of interest.

In reality, the impedance presented by the transistor's  $h_{ie}$ , combined with R1 and R2 will act as a potential divider with the capacitor impedance. Just using  $h_{ie}$  (the smallest of the input-connected resistances, at 2.5kΩ) with an 8Ω capacitor impedance reduces the signal at the base by about 0.3%, which (if ignored) is an acceptable error in the context of this analysis. At much lower frequencies, the capacitor-as-short-circuit assumption would not be valid and we would have to include them.

Small signal analysis deals solely with the signal. Power supplies (and other fixed voltages) are not included. This does not mean that they have no influence. The power supply plays a role in setting bias current, which in turn sets the values of the  $h$ -parameters. The small signal analysis uses a linear approximation of the circuit. Mathematically, this means that we can look at the effect of different inputs to the circuit individually and add the results up afterwards. Thus we can analyse the effect on the signal with the power supplies (and other fixed voltages) set to zero.

### Circuit equivalents

To perform the small signal analysis we draw an equivalent circuit for the whole circuit we are analysing. Each transistor is replaced with its own equivalent circuit, using whatever model we have chosen (Fig.3 in

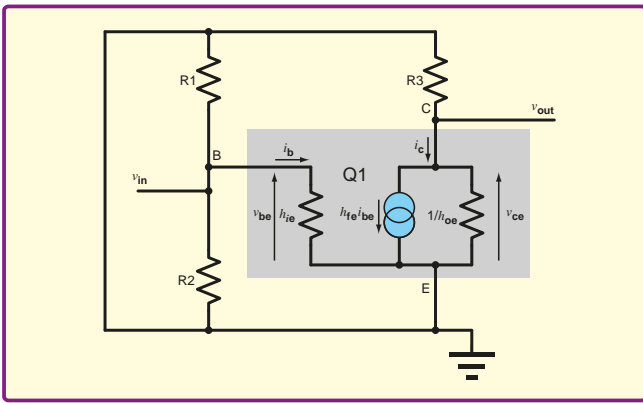

Fig. 5. Circuit for small signal analysis of Fig. 2

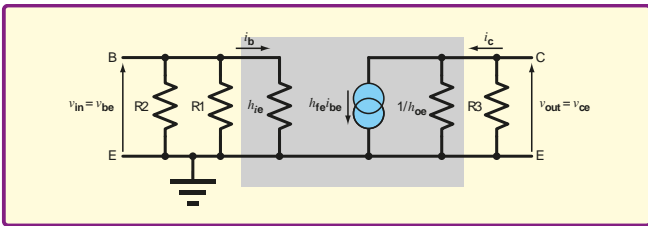

Fig. 6. The redrawn circuit of Fig. 5

our case). The power supplies are set to zero, so, for example, all  $V_{CC}$  connections in Fig. 2 become grounds.

The small signal equivalent circuit for Fig. 2 is shown in Fig. 5. The transistor equivalent circuit is shown with a shaded background to make it clearer. The resistors from Fig. 2 retain their same labels and locations in the circuit. The power supply connections are now grounds, as just discussed. The capacitors have been replaced with short circuits, also discussed above.

A careful look at Fig. 5 will reveal that it can be redrawn with a simpler layout. R1 and R2 both connect to Q1's base at one end and to ground at the other – they are in parallel and parallel with  $h_{ie}$ . Similarly, R3 is in parallel with  $1/h_{oe}$ . The circuit in Fig. 5 is shown redrawn in Fig. 6, which is exactly the same circuit as Fig. 5, only the layout has changed to make the schematic easier to read.

We can use Fig. 6 to calculate the circuit's voltage gain. As  $v_{in}$  connects directly to the base it is applied across  $h_{ie}$  and  $v_{in} = v_{be}$ , so the base current is:

$$i_b = \frac{v_{in}}{h_{ie}}$$

The current source in the transistor produces a current of  $h_{fe}i_b$  which flows through the parallel combination of  $1/h_{oe}$  and R3. Call this parallel resistance  $R_p$ . There is no output current flow elsewhere, whether or not the coupling capacitor is regarded as a short, because we are considering conditions when no load is applied to the circuit in Fig. 2. The output voltage is equal to the collector voltage and is the voltage drop due to  $h_{fe}i_b$  flowing through  $R_p$ . This is:

$$V_{out} = h_{fe}i_bR_p$$

Using the previous equation for  $i_b$  we get:

$$v_{out} = h_{fe} \left( \frac{v_{in}}{h_{ie}} \right) R_p,$$

which can be rearranged to get the gain  $v_{out}/v_{in}$  as:

$$\frac{v_{out}}{v_{in}} = \frac{h_{fe}R_p}{h_{ie}}$$

Without the Early effect  $h_{oe}$  is zero, so the corresponding resistor is infinite and  $R_p = R3 = 6k\Omega$ . With our example values, the voltage gain is 240. With a  $100k\Omega$   $1/h_{oe}$  resistor in parallel with R3,  $R_p$  becomes  $5.66k\Omega$  and the gain reduces to 226, about a 6% reduction. This is similar to the impact of the Early

effect on the bias conditions and could be reasonably ignored in a rough hand calculation of the circuit gain.

We have shown how to analyse a circuit, taking into account the influence of the Early effect on transistor output impedance, for both DC or bias conditions and signal handling performance. In the example we have used, the Early effect is not very strong and affects the circuit by a similar amount to variations in resistor tolerance. This will often apply to circuits where the resistors connected to the transistors' collectors have values much smaller than  $1/h_{oe}$ .

There are circuits where the influence of transistor output impedance is much stronger. One example is shown in Fig. 7. Here Q2 forms what is known as an 'active load', a technique commonly used in IC design. The output of this circuit does not have any resistors connected to it, only transistor collectors. The output signal current will be converted to a voltage by flowing through the parallel combination of the two  $1/h_{oe}$  resistors,

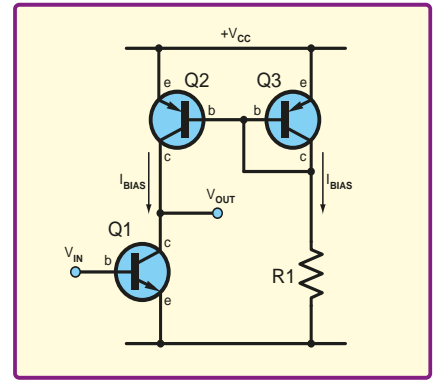



Fig. 7. Common-emitter amplifier with active load. The gain is strongly dependent on  $h_{oe}$  and hence Early effect

giving potentially very high voltage gain. A weaker Early effect will give a higher gain.

In Fig. 7 transistors Q2 and Q3 form what is called 'current mirror', in which Q2 acts as a current source. Q3 is connected as a diode and provides a fixed  $V_{BE}$  voltage for Q2, which therefore, will ideally provide a fixed bias current for Q1, to set its operating point. The bias current is copied, or mirrored, from Q3 to Q2, hence the name current mirror.

Current mirrors are commonly used to provide bias in IC design. Here we would like Q2 to behave as an ideal current source, but, of course, the Early effect causes it to deviate from this.



# CRICKLEWOOD ELECTRONICS

Established 1981



Frustrated with your supplier?  
Visit our component packed website for a vast range of parts - old and new, many unavailable elsewhere!  
[www.cricklewoodelectronics.com](http://www.cricklewoodelectronics.com)

**1000's OF PRICES REDUCED!**

Alternatively phone us on 020 8452 0161 with your requirements.

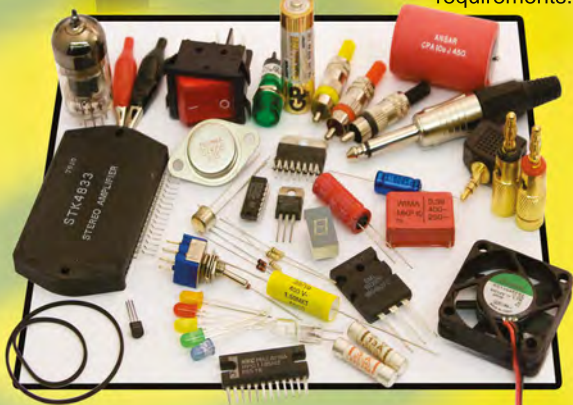

Visit our Shop, Call or Buy online at:  
[www.cricklewoodelectronics.com](http://www.cricklewoodelectronics.com)  
**020 8452 0161** Visit our shop at:  
40-42 Cricklewood Broadway  
London NW2 3ET

## All switched on

**D**UE to their totally mechanical nature, switches rank as one of the most low-tech components used in electronics. In general, this makes them very straightforward to use, but there can be a few puzzles to sort out from time-to-time.

Also, some of the nomenclature and terminology associated with switches can be a bit confusing for newcomers. The number of different types on offer seems to have grown over the years, and care needs to be taken when selecting switches.

### Hello dolly

Most of the switches used in electronic projects are the more basic types, such as a simple on/off switch. Even the most basic of switches are available in a number of different formats, but the slider and toggle types are probably the most popular choices. They are also likely to be the cheapest options.

Slider switches are usually the cheapest of all. These have a small sliding control knob which is often something less than smooth in operation. Many of these switches are very much in the 'cheap and cheerful' category, and in my experience they have proved to be less reliable than other types.

They can also be a bit awkward to use due to their relatively complex mounting arrangements. They typically require a small rectangular cutout for the slider knob and two small mounting holes for the screws that hold the switch in place.

A toggle switch is operated via a small lever that is called a 'dolly'. I am not sure how this name was obtained, but 'dolly' is an old name for a short pole, so it may have been derived from this.

Anyway, the standard toggle switches have their origins in the days of valve equipment, and are very large by modern electronic standards. They may still be required when switching high voltages and (or) currents, but most projects require one of the much smaller miniature or sub-miniature types.

Toggle switches are easy to use because they normally require just one round mounting hole. The smallest types tend to be a bit fragile, which is perhaps inevitable given their diminutive size, but care needs to be taken not to over-tighten the fixing nut when fitting these switches.

Basic switches are available in other forms, such as rocker, rotary, and pushbutton types. The rocker type, as used in modern light switches, is usually relatively large and intended for something like mains on/off switching. Fitting them to a panel can be relatively difficult, with some of these switches being a push fit into a

large rectangular cut-out.

This is simple enough in theory, but in practice, the cutout has to be made with a high degree of precision. If it is fractionally too small the switch will not fit, but make the cut-out very slightly too large and the switch will not clip into place reliably.

Rotary switches have a standard control shaft and threaded mounting shaft, much like a potentiometer. Their relatively large size makes them far from ideal for many modern projects, but they are a good choice for something like mains on/off switching where smaller types are unsuitable.

### On the button

Pushbutton switches exist in a wide range of shapes and sizes, but the basic types are usually quite easy to use, requiring a single round mounting hole. An important point to bear in mind with pushbutton switches is that they exist in *two* forms, which are the *biased* and *normal* types.

With a biased switch, the user presses the button to move the switch to its second state, but the switch springs back to its original position and state as soon as it is released. Typical applications for this type of component are as a reset switch, or to trigger some sort of action such as an emergency cutout.

An item of this type is sometimes referred to as a 'momentary operation' switch in component catalogues. Some of the more complex pushbutton switches have biased operation, as do a few toggle types.

Non-biased switches have what is normally termed 'successive operation'. This means that the switch changes state each time it is operated. For instance, pressing an on/off switch the first time would switch the equipment on, operating it again would switch the equipment off, another press would switch the equipment on again, and so on.

Simple pushbutton switches are available in the 'push-to-make' and 'push-to-break' varieties. Most of these switches are of the former type, where the switch is normally open (off), and pressing the button produces a connection between its two tags. A 'push-to-break' switch operates in the reverse way, with the contacts closed (on) until the button is operated. Where no guidance about the required type is given in a components list, it will almost certainly be a 'push-to-make' switch that is needed.

### Making contacts

When dealing with two-way switches you soon encounter terms such as SPST and DPDT. These indicate the contact

arrangement of the switch, and there are four types of simple switch. The terms used to describe them and their normal abbreviations are:

Contact Arrangement	Abbreviation
Single-pole, single-throw	SPST
Single-pole, double-throw	SPDT
Double-pole, single-throw	DPST
Double-pole, double-throw	DPDT

The simplest of these is the SPST (single-pole single-throw) type, which has two tags and is a simple on/off switch. A DPST (double-pole single-throw) switch is basically just two on/off switches in a single component and operated in unison.

An SPDT (single-pole double-throw) switch is also known as a 'changeover' switch, and has three tags rather than the two of a simple on/off type. The middle tag, which is called the 'pole', connects to one or other of the other two contacts, depending on the setting of the switch. A DPDT (double-pole double-throw) switch is effectively two SPDT switches in a single case and operating in unison. Fig.1 shows the tag arrangements normally used for all four types of switch, and the way in which they relate to the circuit symbols.

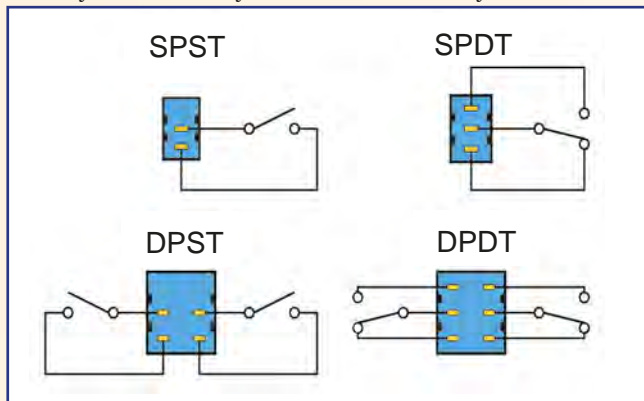

Fig. 1. The four basic types of two-way switch. A DPDT switch can be used in place of any of the others by using only the appropriate tags and ignoring the others

When dealing with switches, it is best not to jump to conclusions, and while most simple switches use one of the contact arrangements shown in Fig.1, there are certainly some exceptions. When dealing with any switch of a type that you have not used before it is a good idea to do a quick check with a continuity tester to determine which tags are connected together at each setting of the switch. Any test meter should be able to make continuity checks, but something as basic as an improvised tester based on a battery and torch bulb or LED/resistor is sufficient for basic testing of this type.

Mistakes in the wiring to switches can produce catastrophic faults, such as short-circuits on the supply lines. Faults of this type can cause damage to components and are potentially dangerous. It is best to make some checks and proceed with certainty rather than jumping to conclusions and hoping for the best.

Checking the contact arrangement of a switch should help to avoid the classic mistake of getting the two positions of the switch confused. This mistake will be readily apparent with something like an on/off switch, but it could be far less obvious with something like a range or mode switch. The normal on and off positions for single-throw toggle switches is shown in Fig.2 (top). The middle and lower tags of a double-throw toggle switch are normally connected together when the dolly is in the 'up' position, as in the lower drawing of Fig.2.

Slider switches have very simple mechanisms that operate in the opposite fashion, with the middle and upper tags connected together when the control knob is in the 'up' position. However, with both types of switch there could be some exceptions, and it is advisable to make some checks using a continuity tester before connecting a switch.

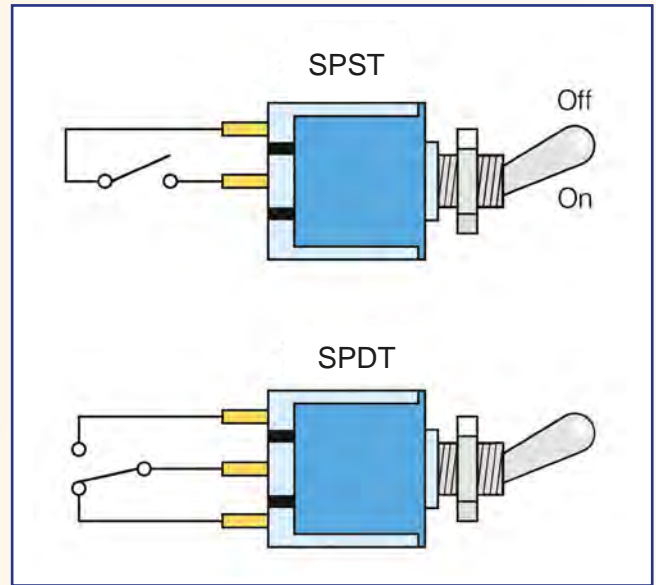

Fig.2. Most toggle switches, whether of the standard or miniature type, operate in the fashion shown here. However, there are some exceptions and it is advisable to make continuity checks before using any switch

### Ratings

When dealing with switches it is important to remember that they have contact ratings. These are the maximum voltages and currents that the switch's contacts can handle safely. With modern circuits, the voltages and currents involved are often very low, and will be well within the capabilities of any normal switch.

With something like a power supply unit, a power amplifier, or a model train controller the currents involved could be relatively high, and a suitably robust switch would then be required. The smaller toggle switches and most slider switches can easily handle the low voltages involved with most modern circuits, but most are unsuitable for something like a mains on/off switch.

The maximum current and voltage ratings for a switch will usually be different for capacitive, inductive, and resistive

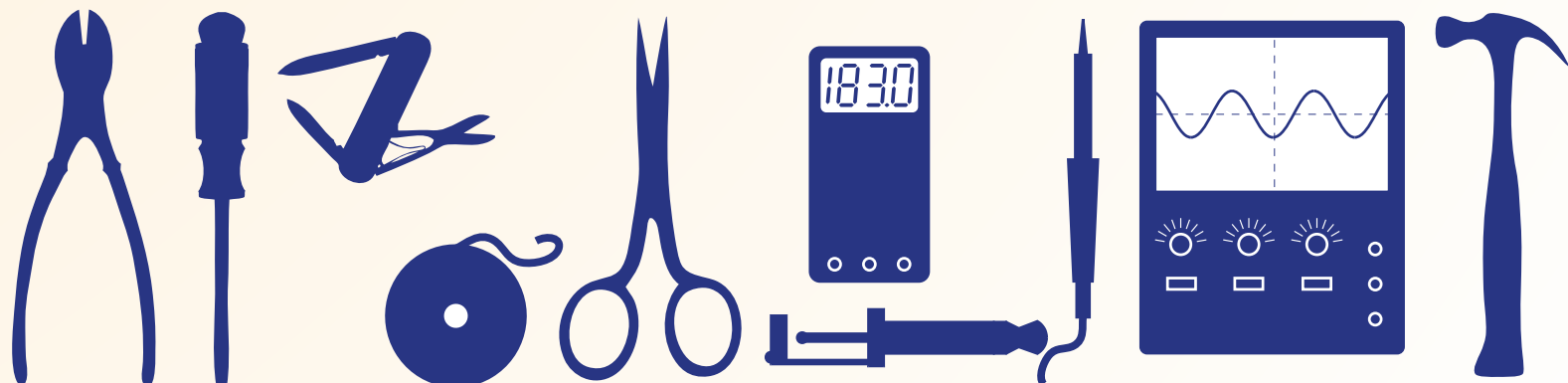

loads. Where more than one set of ratings is quoted, it is safest to use the lowest figures and ignore the others.

### Multiple choice

Some applications require more than the two-way operation of simple switches. A radio might have three or four wavebands, or an item of test equipment could have half a dozen or more measuring ranges.

There are two main approaches to multi-way switching, and one of these is to have a bank of interlinked pushbutton switches. Operating a switch deselects whichever of the switches was selected previously. This ensures that only one switch at a time can be selected, and effectively turns the individual switches into a single multi-way type.

Except where a complex multi-way switch is required, a bank of pushbutton switches is not a popular choice. A bank of switches requires a relatively large amount of space, tends to be awkward to use, and can be quite expensive.

The more usual choice for this type of switching is a 'rotary' switch. These are available in four standard types, which are: 12-way 1-pole, 6-way 2-pole, 4-way 3-pole, and 3-way 4-pole versions. They look much the same, and the only outward difference is the number of pole tags.

These switches normally have adjustable end-stops so that they can be used with anything from two-way operation to their maximum number of ways (Fig.3). Removing the end-stop can be a bit tricky, and it has to be carefully prised free using a very small screwdriver or the blade of a penknife. In many projects, one or more poles of a rotary switch are left unused, and the full number of ways may not be used either. Hence, it is not unusual for many of the tags to be left unconnected.

Fitting a rotary switch to a printed circuit board is not difficult, provided

you make sure that none of the pins are bent. Also, the switch will only fit on to the board if it has a suitable orientation. Things are more difficult when one of these switches has to be hard-wired to the rest of the circuit.

Most of these switches make life a little easier by having the pole tags marked with letters from 'A' to 'C', and the other tags numbered from '1' to '12', as shown in Fig.4. With a 6-way switch for example, tags '1' to '6' are at positions one to six of pole 'A', and tags '7' to '12' are at positions one to six of pole 'B'.

The markings can be a bit difficult to see, because the lettering is necessarily quite small, and it is simply moulded into the plastic body of the component. Putting a small mark next to tag '1' using ink or paint can reduce the risk of you 'losing your bearings' and getting the wiring to the outer ring shifted one tag along from where it should be.

### Make or break

There are usually two ranges of rotary switch on offer in component catalogues, which are the 'break-before-make' and 'make-before-break' types. As the name suggests, a make-before-break switch still has the pole connected to one tag when it comes into contact with the next tag. This has the potential to produce problems with some circuits because it produces a brief short-circuit between two non-pole tags during the switchover. This is avoided with a break-before-make switch, where the pole is

disconnected from the one tag before it is connected to the next. However, this can be problematic with some circuits because it leaves the pole tag connected to nothing during the switchover.

In many cases it does not matter which type of switch is used, and the components list may not specify a particular type. It is important to use the correct type when it is specified in a components list. It is particularly important not to use a make-before-break switch where a break-before-make switch has been specified.

This error can cause problems, such as a brief short-circuit across supply lines each time the switch is operated, or perhaps two outputs would be momentarily connected together. At best, the switch would be rather short-lived, and there could be a risk of costly damage to some of the other components.

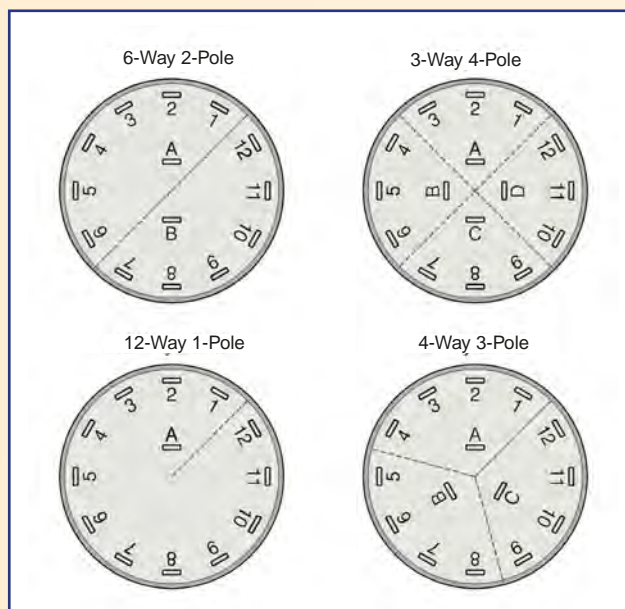

Fig.4. Rotary switches often have moulded markings that show which position each of the outer tags corresponds to, and which ones are associated with each pole tag



Fig.3. Many rotary switches have an adjustable end-stop that can handle anything from 2 to 11-way operation. It is omitted if 12-way operation is required

**Coast**

**Sorting out your bits and pieces? Check out our E-shop...**

...We offer components, modules, kits, Led lighting, musical stuff, Industrial, Contract design, device programming, short-range radio, scientific items ...and some really weird things!

And if we don't have what you need... let us know... we just might add it.

**COAST ELECTRONICS**  
**8 HOLWORTH CLOSE**  
**BOURNEMOUTH**  
**BH11 8PF**  
**Tel:01202 244309**

[www.coastelect.co.uk](http://www.coastelect.co.uk)

EPE IS PLEASED TO BE ABLE TO OFFER YOU THESE

# ELECTRONICS CD-ROMS FLOWCODE 5

Complex electronic systems in minutes

New features include:

- C code views and customisation
- Simulation improvements
- Search and replace
- New variable types
- Project auto-documentation
- Project explorer
- Bookmarks
- Improved chip interrupt features
- Compilation errors and warning
- Interrupts overhaul

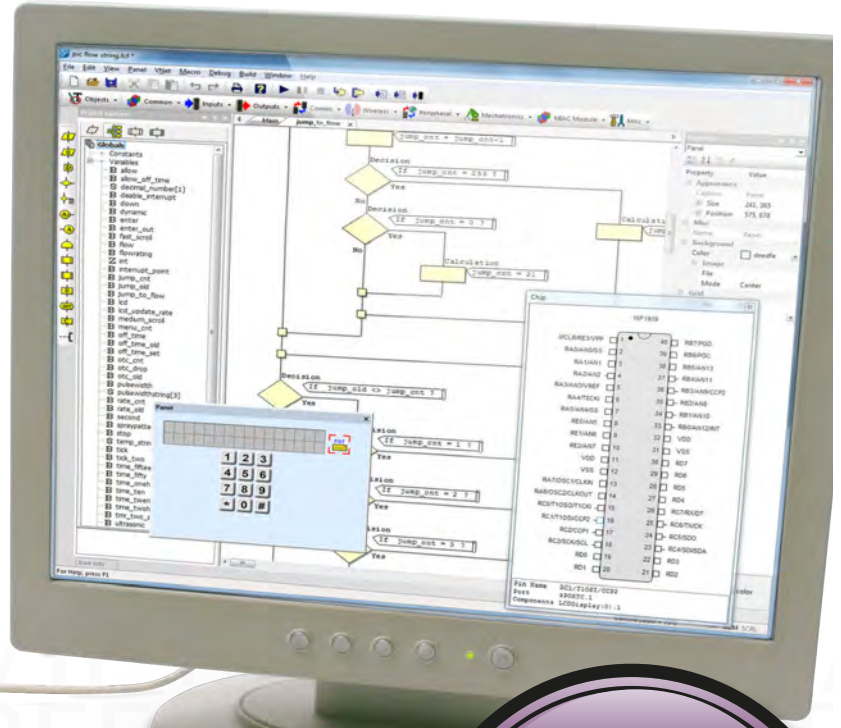

**NEW  
OUT  
NOW**

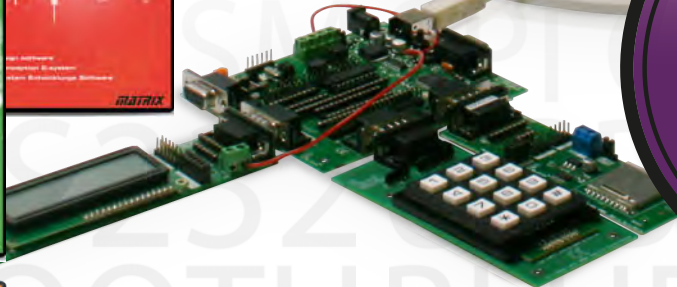

**Flowcode  
PICmicro V5  
is now available  
as a  
download**

The FlowKit can be connected to hardware systems to provide a real time debug facility where it is possible to step through the Flowcode program on the PC and step through the program in the hardware at the same time. The FlowKit can be connected to your own hardware to provide In-Circuit Debug to your finished designs.

## PRICES Prices for each of the CD-ROMs above are: (Order form on third page)

(UK and EU customers add VAT to 'plus VAT' prices)

Hobbyist/Student .....	£45.95 inc. VAT
Professional (Schools/HE/FE/Industry) .....	£149.00 plus VAT
Professional and Flowkit bundle .....	N/A

Flowcode 4  
DSPIC & PIC24

Flowcode 5  
PICMICRO/AVR & ARM  
Download only

£58.80 inc. VAT
£199.00 plus VAT
£220.00 plus VAT

**Please note:** Due to popular demand, Flowcode PICmicro, AVR & ARM V5 are now available as a download. Please include your email address and a username (of your choice) on your order. A unique download code will then be emailed to you. If you require the CDROM as a back-up (available June 2012) then please add an extra £14 to the above price.



# PICmicro TUTORIALS AND PROGRAMMING

## HARDWARE

### VERSION 3 PICmicro MCU development board

Suitable for use with the three software packages listed below.

This flexible development board allows students to learn both how to program PICmicro microcontrollers as well as program a range of 8, 18, 28 and 40-pin devices from the 12, 16 and 18 series PICmicro ranges. For experienced programmers all programming software is included in the PPP utility that comes with the development board. For those who want to learn, choose one or all of the packages below to use with the Development Board.

- Makes it easier to develop PICmicro projects
- Supports low cost Flash-programmable PICmicro devices
- Fully featured integrated displays – 16 individual LEDs, quad 7-segment display and alphanumeric LCD display
- Supports PICmicro microcontrollers with A/D converters
- Fully protected expansion bus for project work
- USB programmable
- Can be powered by USB (no power supply required)

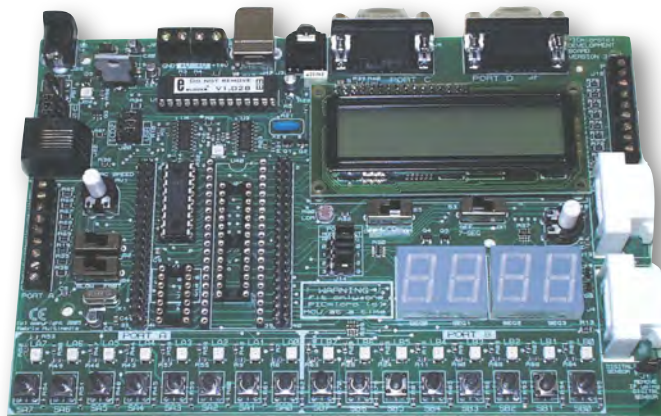

This board is being upgraded, therefore, it is currently unavailable.

**£161** including VAT and postage, supplied with USB cable and programming software

## SOFTWARE

### ASSEMBLY FOR PICmicro V4

(Formerly PICtutor)

Assembly for PICmicro microcontrollers V3.0 (previously known as PICtutor) by John Becker contains a complete course in programming the PIC16F84 PICmicro microcontroller from Arizona Microchip. It starts with fundamental concepts and extends up to complex programs including watchdog timers, interrupts and sleep modes.

The CD makes use of the latest simulation techniques which provide a superb tool for learning: the Virtual PICmicro microcontroller, this is a simulation tool that allows users to write and execute MPASM assembler code for the PIC16F84 microcontroller on-screen. Using this you can actually see what happens inside the PICmicro MCU as each instruction is executed, which enhances understanding.

- Comprehensive instruction through 45 tutorial sections
- Includes Vlab, a Virtual PICmicro microcontroller: a fully functioning simulator
- Tests, exercises and projects covering a wide range of PICmicro MCU applications
- Includes MPLAB assembler
- Visual representation of a PICmicro showing architecture and functions
- Expert system for code entry helps first time users
- Shows data flow and fetch execute cycle and has challenges (washing machine, lift, crossroads etc.)
- Imports MPASM files.

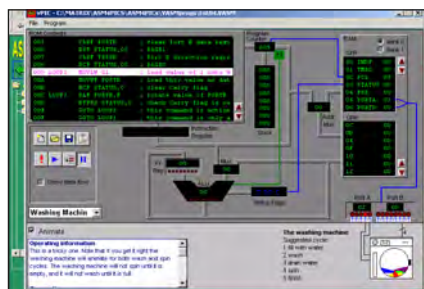

### 'C' FOR 16 Series PICmicro Version 4

The C for PICmicro microcontrollers CD-ROM is designed for students and professionals who need to learn how to program embedded microcontrollers in C. The CD-ROM contains a course as well as all the software tools needed to create Hex code for a wide range of PICmicro devices – including a full C compiler for a wide range of PICmicro devices.

Although the course focuses on the use of the PICmicro microcontrollers, this CD-ROM will provide a good grounding in C programming for any microcontroller.

- Complete course in C as well as C programming for PICmicro microcontrollers
- Highly interactive course
- Virtual C PICmicro improves understanding
- Includes a C compiler for a wide range of PICmicro devices
- Includes full Integrated Development Environment
- Includes MPLAB software
- Compatible with most PICmicro programmers
- Includes a compiler for all the PICmicro devices.

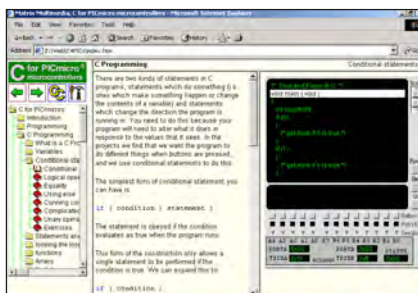

Minimum system requirements for these items: Pentium PC running, 2000, ME, XP; CD-ROM drive; 64MB RAM; 10MB hard disk space. Flowcode will run on XP or later operating systems

### FLOWCODE FOR PICmicro V5 (see opposite page)

Flowcode is a very high level language programming system based on flowcharts. Flowcode allows you to design and simulate complex systems in a matter of minutes. A powerful language that uses macros to facilitate the control of devices like 7-segment displays, motor controllers and LCDs. The use of macros allows you to control these devices without getting bogged down in understanding the programming. When used in conjunction with the Version 3 development board this provides a seamless solution that allows you to program chips in minutes.

- Requires no programming experience
- Allows complex PICmicro applications to be designed quickly
- Uses international standard flow chart symbols
- Full on-screen simulation allows debugging and speeds up the development process.
- Facilitates learning via a full suite of demonstration tutorials
- Produces ASM code for a range of 18, 28 and 40-pin devices
- 16-bit arithmetic strings and string manipulation
- Pulse width modulation
- I2C.

Features include panel creator, in circuit debug, virtual networks, C code customisation, floating point and new components. The Hobbyist/Student version is limited to 4K of code (8K on 18F devices)

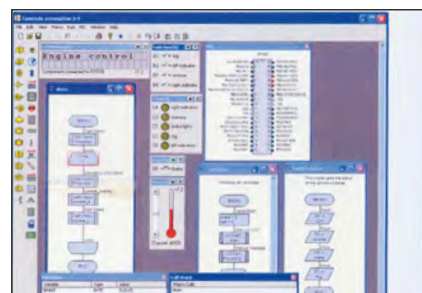

## PRICES

Prices for each of the CD-ROMs above are:  
(Order form on next page)

(UK and EU customers add VAT to 'plus VAT' prices)

Hobbyist/Student	£58.80	inc VAT
Professional (Schools/HE/FE/Industry)	£150	plus VAT
Professional 10 user (Network Licence)	£499	plus VAT
Site Licence	£999	plus VAT
Flowcode Professional (Schools/HE/FE/Industry)	£199	plus VAT
Flowcode 10 user (Network Licence)	£599	plus VAT
Flowcode Site Licence	£999	plus VAT

# CIRCUIT WIZARD

Circuit Wizard is a revolutionary new software system that combines circuit design, PCB design, simulation and CAD/CAM manufacture in one complete package.

Two versions are available, Standard or Professional.

By integrating the entire design process, Circuit Wizard provides you with all the tools necessary to produce an electronics project from start to finish – even including on-screen testing of the PCB prior to construction!

- \* Circuit diagram design with component library (500 components Standard, 1500 components Professional)
- \* Virtual instruments (4 Standard, 7 Professional)
- \* On-screen animation
- \* Interactive circuit diagram simulation
- \* True analogue/digital simulation
- \* Simulation of component destruction
- \* PCB Layout
- \* Interactive PCB layout simulation
- \* Automatic PCB routing
- \* Gerber export
- \* Multi-level zoom (25% to 1000%)
- \* Multiple undo and redo
- \* Copy and paste to other software
- \* Multiple document support

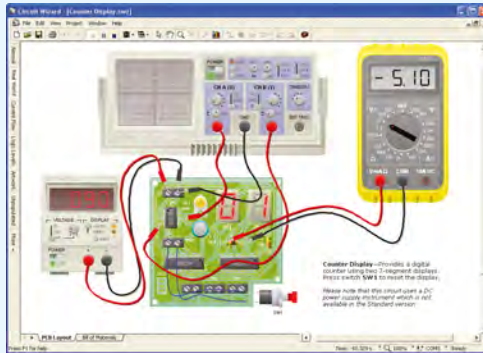

This software can be used with the **Jump Start and Teach-In 2011 series (and the Teach-In 4 book).**

Standard **£61.25** inc. VAT  
Professional **£91.90** inc. VAT

Minimum system requirements for these CD-ROMs: Pentium PC, CD-ROM drive, 32MB RAM, 10MB hard disk space. Windows 2000/ME/XP, mouse, sound card, web browser.

## EPE PIC RESOURCES V2

Version 2 includes the EPE PIC Tutorial V2 series of Supplements (EPE April, May, June 2003)

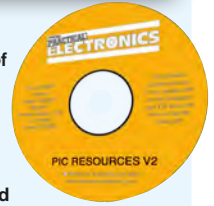

The CD-ROM contains the following Tutorial-related software and texts:

- EPE PIC Tutorial V2 complete series of articles plus demonstration software, John Becker, April, May, June '03
- PIC Toolkit Mk3 (TK3 hardware construction details), John Becker, Oct '01
- PIC Toolkit TK3 for Windows (software details), John Becker, Nov '01

Plus 18 useful texts to help YOU get the most out of your PIC programming.

Price **£14.75** inc. VAT

## ELECTRONIC COMPONENTS PHOTOS

A high quality selection of over 200 jpg images of electronic components. This selection of high resolution photos can be used to enhance projects and presentations or to help with training and educational material. They are royalty free for use in commercial or personal printed projects, and can also be used royalty free in books, catalogues, magazine articles as well as worldwide web pages (subject to restrictions – see licence for full details).



Now contains Irfan View image software for Windows, with quick-start notes included.

Price **£19.95** inc. VAT

### Please send me: CD-ROM ORDER FORM



- Assembly for PICmicro V4
- 'C' for 16 Series PICmicro V4
- Flowcode for PICmicro V5 (DOWNLOAD + CDROM)
- Flowcode for PICmicro V5 (DOWNLOAD ONLY)
- Flowcode for AVR V5 (DOWNLOAD + CDROM)
- Flowcode for AVR V5 (DOWNLOAD ONLY)
- Flowcode for ARM V5 (DOWNLOAD + CDROM)
- Flowcode for ARM V5 (DOWNLOAD ONLY)

Version required:

- Hobbyist/Student
- Professional
- Professional 10 user
- Professional + Flowkit
- Site licence

Email: .....

Username: .....

- Flowcode for dsPIC & PIC24 V4

Note: The software on each version is the same, only the licence for use varies.

- PICmicro Development Board V4 (hardware) – currently unavailable.

- Circuit Wizard – Standard
- Circuit Wizard – Professional
- EPE PIC Resources V2
- Electronic Components Photos

Full name: .....

Address: .....

Post code: ..... Tel. No: .....

Signature: .....

- I enclose cheque/PO in £ sterling payable to WIMBORNE PUBLISHING LTD for £ .....

- Please charge my Visa/Mastercard/Maestro: £ .....

Valid From: ..... Card expiry date: .....

Card No: ..... Maestro Issue No. ....

Card Security Code ..... (The last 3 digits on or just under the signature strip)

## ORDERING ALL PRICES INCLUDE UK POSTAGE

Student/Single User/Standard/Hobbyist Version price includes postage to most countries in the world  
EU residents outside the UK add £5 for airmail postage per order

Professional, Multiple User and Site License Versions – overseas readers add £5 to the basic price of each order for airmail postage (do not add VAT unless you live in an EU (European Union) country, then add VAT at 20% or provide your official VAT registration number).

Send your order to:  
**Direct Book Service**  
**Wimborne Publishing Ltd**  
113 Lynwood Drive, Merley, Wimborne,  
Dorset BH21 1UU

To order by phone ring  
**01202 880299. Fax: 01202 843233**

Goods are normally sent within seven days

E-mail: [orders@wimborne.co.uk](mailto:orders@wimborne.co.uk)

Online shop:

[www.epemag.com](http://www.epemag.com)

# SHERWOOD ELECTRONICS

Buy 10 x £1 Special Packs and choose another one FREE

SP1	15 x 5mm Red Leds	SP131	2 x TL071 Op-amps
SP2	12 x 5mm Green Leds	SP133	20 x 1N4004 diodes
SP3	12 x 5mm Yellow Leds	SP134	15 x 1N4007 diodes
SP5	20 x 5mm 1 part Led clips	SP135	5 x Miniature slide switches
SP6	15 x 3mm Red Leds	SP137	4 x W005 1.5A bridge rectifiers
SP7	12 x 3mm Green Leds	SP138	20 x 2.2/63V radial elect caps
SP8	10 x 3mm Yellow Leds	SP142	2 x Cmos 4017
SP9	20 x 3mm 1 part Led clips	SP143	5 Pairs min. croc. clips (Red+Blk)
SP10	100 x 1N4148 diodes	SP144	5 Pairs min. croc. clips (assorted colours)
SP11	30 x 1N4001 diodes	SP146	10 x 2N3704 transistors
SP12	30 x 1N4002 diodes	SP151	4 x 8mm Red Leds
SP18	20 x BC182B transistors	SP152	4 x 8mm Green Leds
SP20	20 x BC184B transistors	SP153	4 x 8mm Yellow Leds
SP23	20 x BC549B transistors	SP154	15 x BC548B transistors
SP24	4 x Cmos 4001	SP155	6 x 1000/16V radial elect. caps
SP25	4 x 555 timers	SP160	10 x 2N3904 transistors
SP26	4 x 741 Op-amps	SP161	10 x 2N3906 transistors
SP28	4 x Cmos 4011	SP164	2 x C106D thyristors
SP29	4 x Cmos 4013	SP165	2 x LF351 Op-amps
SP33	4 x Cmos 4081	SP166	20 x 1N4003 diodes
SP34	20 x 1N914 diodes	SP167	5 x BC107 transistors
SP36	25 x 10/25V radial elect caps	SP168	5 x BC108 transistors
SP37	12 x 100/35V radial elect caps	SP172	3 x Standard slide switches
SP38	15 x 47/25V radial elect caps	SP173	10 x 220/25V radial elect caps
SP39	10 x 470/16V radial elect caps	SP174	20 x 22/25V radial elect caps
SP40	15 x BC237 transistors	SP175	20 x 1/63V radial elect caps
SP41	20 x Mixed transistors	SP177	8 x 1A 20mm quick blow fuses
SP42	200 x Mixed 0.25W CF resistors	SP178	8 x 2A 20mm quick blow fuses
SP47	5 x Min. PB switches	SP181	5 x Phono plugs - assorted colours
SP49	4 x 4 metres stranded core wire	SP182	20 x 4.7/63V radial elect caps
SP102	20 x 8 pin DIL sockets	SP183	20 x BC547B transistors
SP103	15 x 14 pin DIL sockets	SP186	6 x 1M horizontal trim pots
SP104	15 x 16 pin DIL sockets	SP192	3 x Cmos 4066
SP109	15 x BC557B transistors	SP195	3 x 10mm Yellow Leds
SP112	4 x Cmos 4093	SP197	6 x 20 pin DIL sockets
SP115	3 x 10mm Red Leds	SP198	5 x 24 pin DIL sockets
SP116	3 x 10mm Green Leds	SP199	4 x 2.5mm mono jack plugs
SP118	2 x Cmos 4047	SP200	4 x 2.5mm mono jack sockets
SP124	20 x Assorted ceramic disc caps		
SP130	100 x Mixed 0.5W CF resistors		

Catalogue £1.25 inc. P&P or **FREE** with first order.  
 P&P £2.50 per order. NO VAT  
 Cheques and Postal Orders to:  
**Sherwood Electronics,**  
**10 NEWSTEAD STREET,**  
**MANSFIELD, NOTTS.**  
**NG19 6JJ**

**RESISTOR PACKS - C.Film**

RP3	5 each value - total 365 - 0.25W	£3.65
RP7	10 each value - total 730 - 0.25W	£4.95
RP10	1000 popular values - 0.25W	£7.00
RP4	5 each value - total 305 - 0.5W	£4.65
RP8	10 each value - total 610 - 0.5W	£7.40
RP11	1000 popular values - 0.5W	£10.15

[www.rkeducation.co.uk](http://www.rkeducation.co.uk)  
 electronic projects and components

## RKAmp4



### Amplifier PCB designed for the TDA2009A

- Up to 2x 10 watts
- Ideal for connecting to MP3 players and other portable music players
- Perfect for a portable stereo amplifier
- Produces a high quality sound
- Only £7.99

Available now online from,  
[www.rkonlinestore.co.uk](http://www.rkonlinestore.co.uk)

A wide range of electronic projects are available

# DEEP MEMORY MIXED SIGNAL OSCILLOSCOPES

**NEW** from Pico Technology

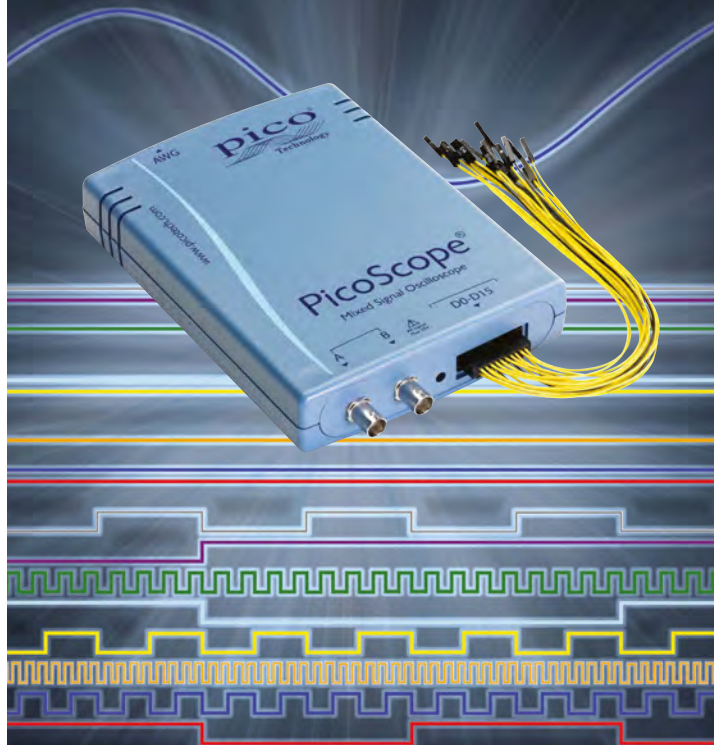

PORTABILITY & PERFORMANCE



PicoScope	3204 MSO	3205 MSO	3206 MSO
Channels	2 Analog 16 Digital		
Bandwidth	60 MHz	100 MHz	200 MHz
Buffer memory	8 MS	32 MS	128 MS
Resolution (enhanced)	8 bits (12 bits)		
Signal generator	Function generator + AWG		
Price	£649 \$1070 €785	£849 \$1400 €1028	£1049 \$1730 €1270

ALL MODELS INCLUDE ADVANCED DIGITAL TRIGGERS, SERIAL DECODING (I<sup>2</sup>C, SPI, RS232, CAN, LIN, FLEXRAY) MASK LIMIT TESTS, SEGMENTED MEMORY, DIGITAL FILTERING, FREE SOFTWARE UPDATES AND 5 YEAR WARRANTY

[www.USBmso.com/PS194](http://www.USBmso.com/PS194)

# NET WORK

by Alan Winstanley

## Hot on the trail

**A FEW** months ago, my eBay account somehow got hacked. The first I knew about it was when eBay locked it: an unauthorised party had tried to sell a vehicle, no less, using my ebay ID. eBay shut it down and refunded the listing fees. I reset the logins and had to set up another direct debit. Annoyingly, the change of logins crippled my eBay 'sniping' service at **Bidnapper.com**, which was in the throes of bidding at the last second for a rare camera; an opportunity that slipped through my fingers.

I thought nothing more about it until a police car turned up one morning and a cheery police officer rang my doorbell, asking to come inside 'for a chat'. He explained that a gang of sophisticated criminals had been 'fencing' vehicles online using stolen identities including mine. Some domain names similar to mine were reeled off, followed by the names of some well-known motor magazines and Internet sites, none of which I was associated with.

Then the penny dropped about my puzzling eBay experience earlier this year. How the Police Service of Northern Ireland (as it turned out to be) could join up some dots, locate my address on mainland Britain and ask the local boys in blue to drop in for a chat is something that my mind boggles at. Apart from anything, it is symptomatic of how tightly integrated the Internet and society have become. During the 2012 London Olympics, the Team GB champion diver Tom Daley was subjected to a 'troll' attack on Twitter by someone who turned out to be living in a guest house down here in Dorset. In the blink of an eye, a 17-year-old youth was arrested by the police and later prosecuted for harassment: traditional laws being applied to infractions on the Internet.

### Off-the-cuff

The Daley case aside, the UK authorities have now been criticised for being too heavy-handed when dealing with often fairly trivial Twitter 'abuse', such as comradely non-PC chatter or sarcasm. In fairness to the police authorities, on top of their heavy workload they are suddenly expected to deal with complaints about abuse appearing on Facebook or Twitter. As my local beat bobby confided, how are they supposed to handle that? Tweets, a way of thinking aloud spontaneously, are no longer merely scraps of wit or banter. As some celebrity footballers have found to their cost, off-the-cuff tweets can be held up for scrutiny by the media.



Thinly stretched police resources are increasingly distracted by the need to feel the collars of wayward tweeters instead of catching vehicle criminals. Many such Facebook or Twitter-related instances of abuse should simply be shrugged off and ignored: it will soon be forgotten and people should move on. The police agree, saying that sometimes people really need to grow up.

### eBay gum!

In my native Yorkshire we say 'there's nowt as queer as folk' and the petty or exasperating behaviour of some users defies belief. eBay is on a roll having become the virtual souk of choice for many wanting to dump their detritus online. A number of sellers have ratings of well over a million, so eBay clearly works well for them as they industriously fill our postal system with little polythene packets. The problem is that everyone has got the same idea, so individual sellers face more competition, the website is becoming over-saturated and items increasingly go unsold.

Even a successful sale can become a bugbear: the buyer of a 99p music CD complained of non-delivery a month later, which resulted in an eBay complaint and a refund being made. Another buyer complained that the cost of actual postage (they had counted the stamps) was slightly lower than had been paid for postage and packing: they complained to eBay and spent their day obsessing over a refund. Another demanded to know where their item was, not content with the fact that the country was under six feet of snow in places.

The eBay way of doing things can be lucrative, but it can also be a source of strife for sellers, who pay for the privilege of their goods appearing on the online auction site. Listing

fees, various display options and final value fees can all mount up. PayPal will deduct its own fee as well, but at least withdrawals now arrive in a bank account in a few hours, not days.

As an exercise, eBay users might want to grab their most recent eBay invoices to check the total cost of listing an item; I saw that goods totalling £175 cost nearly £30 in eBay and PayPal fees alone. A rate of 15% VAT is levied by eBay, which hosts its business affairs in Luxembourg not Britain.

If things go wrong for buyers then a well-established complaints procedure is in place, and you may have additional rights with your credit card

The screenshot shows the eBay homepage for the Electronics category. At the top, there's a search bar and navigation links. Below, there are several product listings with prices and 'Free P&P' offers. A 'DEALS' section highlights specific items like a Tablet, a Finlux TV, and a Toshiba laptop. A 'New fridge?' advertisement is also visible on the right side of the page.

Buying online is now the preference for millions of shoppers, with eBay one of Europe's most popular shopping destinations

provider. Conversely, sellers cannot identify outright poor buyers of the type I mentioned above, and the days of leaving 'Non paying bidder!' alerts with negative feedback have long since gone. More recently, a tiny 'Report a buyer' link has appeared in the eBay dashboard: if you think the buyer made unreasonable demands or left inappropriate feedback, then this is one way of highlighting their poor behaviour. However, it mainly helps eBay to identify a trend, and your plea for summary justice may go unanswered. Just move on.

## Not netiquette

Netiquette – etiquette on the Internet – is a word that has gone out of fashion, as the 'democratisation' of the Internet has made the anarchic medium seem more like the Wild West at times. Up to a point, there can be a 'disconnect' between an Internet user and the consequences of their actions due to the remote networking nature of the Internet. Readers only have to look at a typical video on YouTube to see what happens when users are allowed to post all manner of abusive comments underneath it, almost with impunity. This spoils the experience for everyone else, and the YouTube website seems more like a collective bear-pit than a useful video sharing site sometimes.

To avoid the kind of unpleasantness found elsewhere online, the *EPE Chat Zone* forum has an 'Acceptable Use Policy' (AUP) that's intended to ensure the forum is a friendly and welcoming area, where *EPE* readers can help each other out or exchange their views without fear

The screenshot shows the EPE Chat Zone forum interface. At the top, there is a navigation bar with links for 'Log in now or Register', 'Topics', 'Profile', 'Help', and 'Member List'. Below this is a search bar and a table of forum categories. The 'Raspberry Pi Zone' and 'Radio Bygones' sections are highlighted in red. The table lists various forum topics with their respective post counts, page numbers, last post dates, and last posters.

Topic	Posts	Pages	Last Post	Last Poster
<b>EPE Chat Zone</b>	4783	461	05/11/12 04:43 pm	cjaysharp
<b>Raspberry Pi Zone</b>				
Raspberry Pi Zone	364	16	30/10/12 11:42 am	arw
Net Work - the Internet column	26	9	17/08/12 09:14 am	arw
Shop Talk	118	36	23/10/12 02:39 pm	alexeng
Everything else!	1905	313	05/11/12 11:48 am	lincoln
<b>Radio Bygones</b>				
Computer & Electronics Bygones	385	42	19/10/12 09:08 am	thomasm

The *EPE Chat Zone* forum is a goldmine of resources for *EPE* projects both past and present. Users can edit their post for up to 30 minutes or delete it altogether within 10 minutes

of abuse, trolls or spam spoiling the atmosphere. The forum is not intended as an official channel to contact the publishers; we may accidentally overlook an enquiry and our policy is to provide individual answers to individual queries, as there is seldom an issue that cannot be dealt with by a quick email. The contact addresses are published in every issue.

Our forum appeals to users of all ages and abilities from many countries, and we go to great lengths to ensure that the *EPE* forum operates in a civilised and focused way. The Internet is a great leveller and everyone has equal rights in the *Chat Zone*; mutual respect is the order of the day. If you look at the tone of our *Readout* pages, that's about the right level to expect.

Although it may not have all of the bells and whistles of some other forums, the *EPE Chat Zone* forum has become a goldmine of resources, and the robust legacy Discusware software is very good at allowing scientific notation and formulae to be used in posts. There are some formatting tips in the forum's Help section, and the AUP can be found in the Guidelines for Posting area. We hope *EPE* readers will join us by registering at [www.chatzones.co.uk](http://www.chatzones.co.uk). A number of improvements are getting under way, and

although you do not need to log in to read the forum, you do require logins to post a message.

## Christmas cheer

It is that time of year again, when Christmas festivities are upon us, and all the signs are that Internet traders will face a hectic holiday season: several HTML mailshots bearing Christmas offers just arrived from online retailers as I started to type this sentence. Christmas will again be characterised by a non-stop procession of parcels delivered to our door. Traditional bricks and mortar retailers continue to have a truly torrid time on the High Street, with up to 32 retail shops having closed every day through summer in the UK as consumers move online in search of bargains.

One clothing retailer I know has posted several stern 'No Photography' signs around their premises, because shoppers started using the store's amenities to try a dress or prom gown (wasting two hours of staff time in the process), then using their mobile phone to photograph themselves in the dress before leaving the store to buy it online instead. That kind of galling behaviour is a form of theft, but probably no-one under 35 will understand why it is such a poor, unethical and short-sighted way of conducting one's self. Some shoppers even came back with a dress duly sourced on the Internet, asking if the retailer would alter it for them! The same people will eventually wonder why fewer shops are left in business.

One of the reassuring aspects of buying from Amazon is their offer of a no-quibble guarantee, which for many shoppers is a deal-maker in itself. Everything depends on a timely delivery though, and if this falls down then the whole exercise is a waste of time. Recently, I was immobilised by a shoulder problem for many weeks, but I managed to fire up my web browser and order myself a sling. In my defence, I had limped in agony to a nearby town and tried local pharmacies first. None of them could help, although they offered to order one in for me. Amazon listed such a sling, and even with the cost of next day delivery far exceeding the cost of the product itself, I duly placed an order and retired back to bed, waiting for a truck to arrive.

There would be no delivery next day, I gave up and went back to bed. The courier network website stated that it was on the van at 8.30am (great!), but by 5pm there was no sign of my featherweight package. Suddenly, the online status changed to 'delivered at 9am,' which was physically impossible due to the distance from the depot concerned. Several frantic phone calls later and I was told it had been left outside in a safe place (no it hadn't). I gave up.

The same issue blighted a delivery from a German electronics supplier, with the same courier failing to deliver three times from a nearby depot before shipping it back to Germany. The accounting hassles took five months to clear up. Another consignment of mine was found tossed over the gates of a completely different house at the other end of the street, in total darkness.

Domestic home deliveries are a notorious nightmare for couriers, who might have 80 to 100 or more drops to make every day – there may be no one in to take the goods, the place may be hard to find or too remote to access within the available timeslot. Perhaps there is a conspiracy among couriers to cover their tracks when things go wrong; I am sure that some drivers are overloaded and physically cannot cope with the workload. Somewhere in a country lane, there is probably a hedge with my sling dangling from it, waving in the wind.

I would like to close this month by wishing *Net Work* readers a safe and peaceful Christmas and a more prosperous 2013. I thank the many *EPE* readers who take the trouble to write and especially those who offer their kind feedback, support and encouragement. Although I cannot promise to reply, I enjoy reading your comments, which can be sent by email to [alan@epemag.demon.co.uk](mailto:alan@epemag.demon.co.uk). You can also write to the editor at [editorial@wimborne.co.uk](mailto:editorial@wimborne.co.uk) for possible inclusion in *Readout*, and you could earn a valuable prize!

# DIRECT BOOK SERVICE

**ELECTRONICS TEACH-IN BUNDLE –  
SPECIAL BUNDLE PRICE £14 FOR PARTS 1, 2 & 3**

## ELECTRONICS TEACH-IN 2 CD-ROM USING PIC MICROCONTROLLERS A PRACTICAL INTRODUCTION

This *Teach-In* series of articles was originally published in *EPE* in 2008 and, following demand from readers, has now been collected together in the *Electronics Teach-In 2* CD-ROM.

The series is aimed at those using PIC microcontrollers for the first time. Each part of the series includes breadboard layouts to aid understanding and a simple programmer project is provided.

Also included are 29 *PIC N' Mix* articles, also republished from *EPE*. These provide a host of practical programming and interfacing information, mainly for those that have already got to grips with using PIC microcontrollers. An extra four part beginners guide to using the C programming language for PIC microcontrollers is also included.

The CD-ROM also contains all of the software for the *Teach-In 2* series and *PIC N' Mix* articles, plus a range of items from Microchip – the manufacturers of the PIC microcontrollers. The material has been compiled by Wimborne Publishing Ltd. with the assistance of Microchip Technology Inc.

The Microchip items are: MPLAB Integrated Development Environment V8.20; Microchip Advance Parts Selector V2.32; Treelink; Motor Control Solutions; 16-bit Embedded Solutions; 16-bit Tool Solutions; Human Interface Solutions; 8-bit PIC Microcontrollers; PIC24 Microcontrollers; PIC32 Microcontroller Family with USB On-The-Go; dsPIC Digital Signal Controllers.

CD-ROM Order code ET12 CD-ROM £9.50

Book and CD-ROMs

**FREE  
CD-ROM**

## ELECTRONICS TEACH-IN 3

The three sections of this book cover a very wide range of subjects that will interest everyone involved in electronics, from hobbyists and students to professionals. The first 80-odd pages of *Teach-In 3* are dedicated to *Circuit Surgery*, the regular *EPE* clinic dealing with readers' queries on various circuit design and application problems – everything from voltage regulation to using SPICE circuit simulation software.

The second section – *Practically Speaking* – covers the practical aspects of electronics construction. Again, a whole range of subjects, from soldering to avoiding problems with static electricity and indentifying components, are covered. Finally, our collection of *Ingenuity Unlimited* circuits provides over 40 circuit designs submitted by the readers of *EPE*.

The free cover-mounted CD-ROM is the complete *Electronics Teach-In 1* book, which provides a broad-based introduction to electronics in PDF form, plus interactive quizzes to test your knowledge, TINA circuit simulation software (a limited version – plus a specially written TINA Tutorial), together with simulations of the circuits in the *Teach-In 1* series, plus Flowcode (a limited version) a high level programming system for PIC microcontrollers based on flowcharts.

The *Teach-In 1* series covers everything from Electric Current through to Microprocessors and Microcontrollers and each part includes demonstration circuits to build on breadboards or to simulate on your PC. There is also a MW/LW Radio project in the series. The contents of the book and Free CD-ROM have been reprinted from past issues of *EPE*.

160 pages Order code ET13 £8.50

Bundle Price £14.00

The books listed have been selected by *Everyday Practical Electronics* editorial staff as being of special interest to everyone involved in electronics and computing. They are supplied by mail order direct to your door. Full ordering details are given on the last book page.

**FOR A FURTHER SELECTION  
OF BOOKS AND CD-ROMS  
SEE THE UK SHOP ON OUR  
WEBSITE –  
www.epemag.com**

**All prices include UK postage**

1

## COMPUTING

## ELECTRONICS TEACH-IN 4

**FREE  
CD-ROM**

## ELECTRONICS TEACH-IN 4

A Broad-Based Introduction to Electronics plus FREE CD-ROM

The *Teach-In 4* book covers three of the most important electronics units that are currently studied in many schools and colleges. These include, Edexcel BTEC level 2 awards and the electronics units of the new Diploma in Engineering, Level 2.

The Free cover-mounted CD-ROM contains the full Modern Electronics Manual, worth £29.95. The Manual contains over 800 pages of electronics theory, projects, data, assembly instructions and web links.

A package of exceptional value that will appeal to all those interested in learning about electronics or brushing up on their theory, be they hobbyists, students or professionals.

144 pages Order code ET14 £8.99

## RADIO

## AN INTRODUCTION TO RADIO WAVE PROPAGATION

J.G. Lee

Radio wave propagation has its origins in the world of solar physics. The Sun's radiation provides the mechanism for the formation of the ionosphere. How the ionosphere is formed, and how it provides long-distance communication, is carefully explained. Non-ionospheric propagation, including 'moonbounce' or satellite communications, is covered as well.

This book has been written with the average electronic hobbyist in mind. Technical language and mathematics have been kept to a minimum in order to present a broad, yet clear, picture of the subject. The radio amateur, as well as the short-wave listener, will find explanations of the propagation phenomena which both experience in their pursuit of communications enjoyment.

116 pages Order code BP293 £4.45

## PROJECT CONSTRUCTION

## IC 555 PROJECTS

E. A. Parr

Every so often a device appears that is so useful that one wonders how life went on before without it. The 555 timer is such a device. Included in this book are over 70 circuit diagrams and descriptions covering basic and general circuits, motor car and model railway circuits, alarms and noise makers as well as a section on 556, 558 and 559 timers. (Note. No construction details are given.) A reference book of invaluable use to all those who have any interest in electronics, be they professional engineers or designers, students or hobbyists.

167 pages Order code BP44 £5.49

## HOW TO USE OSCILLOSCOPES AND OTHER TEST EQUIPMENT

R. A. Penfold

This book explains the basic function of an oscilloscope, gives a detailed explanation of all the standard controls, and provides advice on buying. A separate chapter deals with using an oscilloscope for fault finding on linear and logic circuits, plenty of example waveforms help to illustrate the control functions and the effects of various fault conditions. The function and use of various other pieces of test equipment are also covered, including signal generators, logic probes, logic pulsers and crystal calibrators.

104 pages Order code BP267 £5.49

## ELECTRONIC PROJECT BUILDING FOR BEGINNERS

R. A. Penfold

This book is for complete beginners to electronic project building. It provides a complete introduction to the practical side of this fascinating hobby, including the following topics:

Component identification, and buying the right parts; resistor colour codes, capacitor value markings, etc; advice on buying the right tools for the job; soldering; making easy work of the hard wiring; construction methods, including stripboard, custom printed circuit boards, plain matrix boards, surface mount boards and wire-wrapping; finishing off, and adding panel labels; getting "problem" projects to work, including simple methods of fault-finding.

In fact everything you need to know in order to get started in this absorbing and creative hobby.

135 pages Order code BP392 £5.99

## FREE DOWNLOADS TO PEP-UP AND PROTECT YOUR PC

R. A. Penfold

Bob Penfold, uses his vast knowledge and experience in computing to guide you simply through the process of finding reliable sites and sources of free software that will help optimize the performance and protect your computer against most types of malicious attack.

Among the many topics covered are: Using Windows 7 optimization wizard; PCPitstop for advice on improving performance, reducing start up times, etc; Free optimization scans and the possibility of these being used as a ploy to attack your PC; Free programs such as Ccleaner, Registry checker and PCPal optimization software; Internet speed testing sites and download managers; Overclocking sites, together with warnings about using this technique; Sites and software for diagnosis of hardware faults, including scanning for out of date drivers and finding suitable replacements; Free Antivirus software and programs that combat specific types of malware; Firewalls; Search engines to identify mystery processes listed in Windows Task Manager.

128 pages Order code BP722 £7.99

## COMPUTING FOR THE OLDER GENERATION

Jim Gatenby

Among the many practical and useful ideas for using your PC that are covered in this book are: Choosing, setting up and understanding your computer and its main components. Writing letters, leaflets, invitations, etc., and other word processing jobs. Keeping track of your finances using a spreadsheet. Recording details of holidays and other ideas using a database. Using the Internet to find useful information, and email to keep in touch with family and friends. Making 'back-up' copies of your work and checking for viruses. How to use Windows XP to help people with impaired vision, hearing or mobility.

308 pages Order code BP601 £8.99

**FOR MORE BOOKS  
& CD-ROMS  
CHECK OUT  
www.epemag.com**

# FAULT FINDING, CIRCUITS AND DESIGN

**STARTING ELECTRONICS – 4th Edition**  
**Keith Brindley**

A Starting Electronics is unrivalled as a highly practical introduction for technicians, non-electronic engineers, software engineers, students, and hobbyists. Keith Brindley introduces readers to the functions of the main component types, their uses, and the basic principles of building and designing electronic circuits. Breadboard layouts make this very much a ready-to-run book for the experimenter, and the use of readily available, inexpensive components makes this practical exploration of electronics easily accessible to all levels of engineer and hobbyist.

Other books tell readers what to do, but sometimes fail to explain why – Brindley gives readers hands-on confidence in addition to real scientific knowledge, and insight into the principles as well as the practice. All written explanations and steps are supplemented with numerous photos, charts, tables and graphs. Concepts and practical aspects are explained thoroughly with mathematical formulae and technical schematic drawings.

Each chapter introduces a concept or tool, explains the basic theory, and provides clear instructions for a simple experiment to apply the concept or tool, with quiz sections and answers, at the end of each chapter.

296 pages

**Order code NE100    £18.99**



**HOW ELECTRONIC THINGS WORK – AND WHAT TO DO WHEN THEY DON'T**  
**Robert Goodman**

You never again have to be flummoxed, flustered or taken for a ride by a piece of electronics equipment. With this fully illustrated, simple-to-use guide, you will get a grasp on the workings of the electronic world that surrounds you – and even learn to make your own repairs.

You don't need any technical experience. This book gives you: Clear explanations of how things work, written in everyday language. Easy-to-follow, illustrated instructions on using test equipment to diagnose problems. Guidelines to help you decide for or against professional repair. Tips on protecting your expensive equipment from lightning and other electrical damage, lubrication and maintenance suggestions.

Covers: colour TVs, VCRs, radios, PCs, CD players, printers, telephones, monitors, camcorders, satellite dishes, and much more!

394 pages

**Order code MGH3    £21.99**

**PIC IN PRACTICE (2nd Edition)**  
**David W. Smith**

A graded course based around the practical use of the PIC microcontroller through project work. Principles are introduced gradually, through hands-on experience, enabling hobbyists and students to develop their understanding at their own pace. The book can be used at a variety of levels.

Contents: Introduction to the PIC microcontroller; Programming the 16F84 microcontroller; Introductory projects; Headers, porting code – which micro?; Using inputs; Keypad scanning; Program examples; The 16C54 microcontroller; Alphanumeric displays; Analogue to digital conversion; Radio transmitters and receivers; EEPROM data memory; Interrupts; The 12 series 8-pin microcontroller; The 16F87X microcontroller; The 16F62X microcontroller; Projects; Instruction set, files and registers; Appendices; Index.

308 pages

**Order code NE39    £24.99**



**PRACTICAL ELECTRONIC FAULT FINDING AND TROUBLESHOOTING**  
**Robin Pain**

To be a real fault finder, you must be able to get a feel for what is going on in the circuit you are examining. In this book Robin Pain explains the basic techniques needed to be a fault finder.

Simple circuit examples are used to illustrate principles and concepts fundamental to the process of fault finding. This is not a book of theory, it is a book of practical tips, hints and rules of thumb, all of which will equip the reader to tackle any job. You may be an engineer or technician in search of information and guidance, a college student, a hobbyist building a project from a magazine, or simply a

keen self-taught amateur who is interested in electronic fault finding but finds books on the subject too mathematical or specialised.

The fundamental principles of analogue and digital fault finding are described (although, of course, there is no such thing as a "digital fault" – all faults are by nature analogue). This book is written entirely for a fault finder using only the basic fault-finding equipment: a digital multimeter and an oscilloscope. The treatment is non-mathematical (apart from Ohm's law) and all jargon is strictly avoided.

274 pages

**Order code NE22    £41.99**

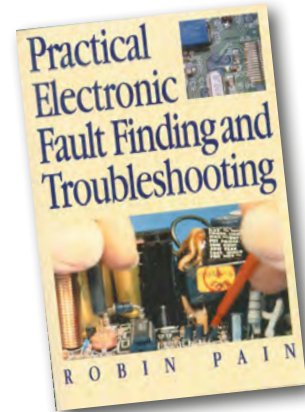

## AUDIO AMPS

**BUILDING VALVE AMPLIFIERS**  
**Morgan Jones**

The practical guide to building, modifying, fault-finding and repairing valve amplifiers. A hands-on approach to valve electronics – classic and modern – with a minimum of theory. Planning, fault-finding, and testing are each illustrated by step-by-step examples.

A unique hands-on guide for anyone working with valve (tube in USA) audio equipment – as an electronics experimenter, audiophile or audio engineer.

Particular attention has been paid to answering questions commonly asked by newcomers to the world of the vacuum tube, whether audio enthusiasts tackling their first build, or more experienced amplifier designers seeking to learn the ropes of working with valves. The practical side of this book is reinforced by numerous clear illustrations throughout.

368 pages

**Order code NE40    £29.00**

**VALVE AMPLIFIERS**  
**Second Edition. Morgan Jones**

This book allows those with a limited knowledge of the field to understand both the theory and practice of valve audio amplifier design, such that they can analyse and modify circuits, and build or restore an amplifier. Design principles and construction techniques are provided so readers can devise and build from scratch, designs that actually work.

The second edition of this popular book builds on its main strength – exploring and illustrating theory with practical applications. Numerous new sections include: output transformer problems; heater regulators; phase splitter analysis; and component technology. In addition to the numerous amplifier and preamplifier circuits, three major new designs are included: a low-noise single-ended LP stage, and a pair of high voltage amplifiers for driving electrostatic transducers directly – one for headphones, one for loudspeakers.

288 pages

**Order code NE33    £40.99**

## BOOK ORDER FORM

Full name: .....

Address: .....

.....

..... Post code: ..... Telephone No: .....

Signature: .....

I enclose cheque/PO payable to DIRECT BOOK SERVICE for £ .....

Please charge my card £ ..... Card expiry date.....

Card Number ..... Maestro Issue No.....

Valid From Date ..... Card Security Code ..... (the last three digits on or just below the signature strip)

Please send book order codes: .....

.....

Please continue on separate sheet of paper if necessary

## BOOK ORDERING DETAILS

**All prices include UK postage.** For postage to Europe (air) and the rest of the world (surface) please add £3 per book. For the rest of the world airmail add £4 per book. CD-ROM prices include VAT and/or postage to anywhere in the world. Send a PO, cheque, international money order (£ sterling only) made payable to **Direct Book Service** or card details, Visa, Mastercard, or Maestro to: **DIRECT BOOK SERVICE, WIMBORNE PUBLISHING LIMITED, 113 LYNWOOD DRIVE, MERLEY, WIMBORNE, DORSET BH21 1UU.**

Books are normally sent within seven days of receipt of order, but please allow 28 days for delivery – more for overseas orders. *Please check price and availability (see latest issue of Everyday Practical Electronics) before ordering from old lists.*

**For a further selection of books see the next two issues of EPE.**  
Tel 01202 880299 Fax 01202 843233. E-mail: [dbs@wimborne.co.uk](mailto:dbs@wimborne.co.uk)  
Order from our online UK shop at: [www.epemag.com](http://www.epemag.com)

# PCB SERVICE

CHECK US OUT ON THE WEB



Printed circuit boards for most recent *EPE* constructional projects are available from the *PCB Service*, see list. These are fabricated in glass fibre, and are fully drilled and roller tinned. Double-sided boards are **NOT plated through hole** and will require 'vias' and some components soldering to both sides. All prices include VAT and postage and packing. Add £2 per board for airmail outside of Europe. Remittances should be sent to **The PCB Service, Everyday Practical Electronics, Wimborne Publishing Ltd., 113 Lynwood Drive, Merley, Wimborne, Dorset BH21 1UU. Tel: 01202 880299; Fax 01202 843233; Email: orders@epemag.wimborne.co.uk. On-line Shop: www.epemag.com.** Cheques should be crossed and made payable to *Everyday Practical Electronics (Payment in £ sterling only)*.

**NOTE: While 95% of our boards are held in stock and are dispatched within seven days of receipt of order, please allow a maximum of 28 days for delivery – overseas readers allow extra if ordered by surface mail.**

**Back numbers or photocopies of articles are available if required – see the Back Issues page for details. WE DO NOT SUPPLY KITS OR COMPONENTS FOR OUR PROJECTS.**

PROJECT TITLE	ORDER CODE	COST
<b>NOVEMBER '11</b>		
★ Digital Capacitor Leakage Meter	826	£10.11
One-of-Nine Switch Indicator		
– Main Board	827	} pair £11.27
– Remote Display Board	828	
<b>DECEMBER '11</b>		
★ Wideband Oxygen Sensor Controller	829	£11.47
★ WIB (Web Server In A Box)	830	£9.72
★ Ginormous 7-segment LED Panel Meter		
– Master (KTA-255v2)	831	£12.67
– Slave (KTA-256v2)	832	£5.05
– Programmed Atmega328		£10.13
<b>JANUARY '12</b>		
Balanced Output Board For The Stereo DAC	833	£9.72
<b>FEBRUARY '12</b>		
★ Air Quality Monitor (CO <sub>2</sub> /CO)	834	£8.75
WIB Connector Daughter PCB	835	£6.80
<b>MARCH '12</b>		
★ Internet Time Display Module	836	£8.16
Solar-Powered Intruder Alarm	837	£9.33
★ Very, Very Accurate Thermometer/Thermostat	840	£9.33
<b>APRIL '12</b>		
★ Digital Audio Signal Generator		
– Main Board (Jay or Alt)	838	} pair £18.86
– Control/Display Board	839	
EHT Stick	841	£9.15
Capacitor Leakage Adaptor For DMMs	842	£9.72
<b>MAY '12</b>		
High-Performance 12V Stereo Amplifier	843	£9.14
Low-Power Car/Bike USB Charger	844	£7.58
★ Solar-Powered Lighting Controller	845	£9.91
Jump Start		
– Plant Pot Moisture Sensor	846	£7.97
– Rain Alarm (Main)	847	} pair £15.36
– Rain Alarm (Sensor)	848	
<b>JUNE '12</b>		
★ Digital Insulation Meter		
– Main/Display	849	} pair £16.33
– DC-DC Converter	850	
Dual Tracking ±0V to 19V PSU		
– Main PCB	851	£9.33
– Front Panel	852	£8.16
– LCD Meter	853	£7.19
Jump Start Quiz Machine		
– Master	854	£7.39
– Contestant	855	£7.39
<b>JULY '12</b>		
★ 16-Bit Digital Potentiometer	856	£13.99
★ Intelligent 12V Fan Controller	857	£10.10
Jump Start – Battery Voltage Checker	858	£9.14
<b>AUGUST '12</b>		
High Performance Microphone Pre-amplifier	859	£7.58
Jump Start – Solar Powered Charger	860	£7.20
★ Electrolytic Capacitor Reformer And Tester	861	£16.71
★ Ultrasonic Cleaner	862	£8.75
High-power DC Motor Speed Controller		
– Non-Reversible	863	£6.50
– Reversible	864	£6.75
(Both boards double-sided)		

PROJECT TITLE	ORDER CODE	COST
<b>SEPTEMBER '12</b>		
Hearing Loop Receiver	865	£8.55
★ Ultrasonic Anti-Fouling For Boats	866	£9.14
Jump Start – Versatile Theft Alarm	867	£9.33
<b>OCTOBER '12</b>		
S/PDIF To TOSLINK Converter	868	£8.16
TOSLINK to S/PDIF Converter	869	£8.16
★ Digital Lighting Controller		
– Master Board	870	£12.05
– Slave Board	871	£16.72
Jump Start – Crazy Eyes	872	£7.78
– Ghostly Sounds	873	£8.16
<b>NOVEMBER '12</b>		
Hearing Loop Level Meter	874	£9.53
RFID Security System	875	£7.75
Jump Start – Frost Alarm	876	£8.55
<b>DECEMBER '12</b>		
Hot Wire Cutter – Controller	877	£8.55
★ Universal USB Data Logger – Part 1 (double-sided)	878	£16.52
Jump Start – Mini Christmas Lights	879	£10.69
<b>JANUARY '13</b>		
Low-Capacitance Adaptor for DMMs	880	£8.55
★ 3-Input Stereo Audio Switcher		
– Main Board	881	} pair £20.00
– Switch Board	882	
Stereo Compressor – Main Board	883	£12.63
Jump Start – iPod Speaker	884	£8.16

Please check price and availability in the latest issue. A large number of older boards are listed on, and can be ordered from, our website.

Boards can only be supplied on a payment with order basis.

## EPE SOFTWARE

★ All software programs for *EPE* Projects marked with a star, and others previously published can be downloaded free from the Library on our website, accessible via our home page at: [www.epemag.com](http://www.epemag.com)

## PCB MASTERS

PCB masters for boards published from the March '06 issue onwards can also be downloaded from our website ([www.epemag.com](http://www.epemag.com)); go to the 'Library' section.

## EPE PRINTED CIRCUIT BOARD SERVICE

Order Code	Project	Quantity	Price
.....	.....	.....	.....
Name	.....	.....	.....
Address	.....	.....	.....
.....	.....	.....	.....
Tel. No.	.....	.....	.....
I enclose payment of £..... (cheque/PO in £ sterling only) to:			
<b>Everyday Practical Electronics</b>			
  			
Card No.	.....	.....	.....
Valid From	.....	Expiry Date	.....
Card Security No.	.....	Maestro Issue No.	.....
Signature	.....		
<b>Note:</b> You can also order PCBs by phone, Fax or Email or via the Shop on our website on a secure server:			
<a href="http://www.epemag.com">http://www.epemag.com</a>			





# CLASSIFIED

## ADVERTISEMENTS

If you want your advertisements to be seen by the largest readership at the most economical price our classified page offers excellent value. The rate for semi-display space is £10 (+VAT) per centimetre high, with a minimum height of 2.5cm. All semi-display adverts have a width of 5.5cm. The prepaid rate for classified adverts is 40p (+VAT) per word (minimum 12 words).

All cheques, postal orders, etc., to be made payable to Everyday Practical Electronics. **VAT must be added.** Advertisements, together with remittance, should be sent to Everyday Practical Electronics Advertisements, 113 Lynwood Drive, Merley, Wimborne, Dorset, BH21 1UU. Phone: 01202 880299. Fax: 01202 843233. Email: [stewart.kearn@wimborne.co.uk](mailto:stewart.kearn@wimborne.co.uk). For rates and information on display and classified advertising please contact our Advertisement Manager, Stewart Kearn as above.

### BOWOOD ELECTRONICS LTD

*Suppliers of Electronic Components*

Place a secure order on our website or call our sales line

All major credit cards accepted

Web: [www.bowood-electronics.co.uk](http://www.bowood-electronics.co.uk)

Unit 10, Boythorpe Business Park, Dock Walk, Chesterfield,  
Derbyshire S40 2QR. Sales: 01246 200222

Send 60p stamp for catalogue

**MAINS TRANSFORMERS for  
OBSOLETE & VINTAGE  
EQUIPMENT**

For full info Visit Section 16C

[www.partridgeelectronics.co.uk](http://www.partridgeelectronics.co.uk)

### CPS Solar

Solar panels, solar cells, and many more alternative energy products for battery charging etc, please visit our website for further info or call

Tel: 0870 765 2334.

[www.solarpanelsonline.co.uk](http://www.solarpanelsonline.co.uk)

### MISCELLANEOUS

VALVES AND ALLIED COMPONENTS IN STOCK. Phone for free list. Valves, books and magazines wanted. Geoff Davies (Radio), tel. 01788 574774.

Everyday Practical Electronics reaches more UK readers than any other UK monthly hobby electronics magazine, our sales figures prove it.

We have been the leading monthly magazine in this market for the last twenty-five years.

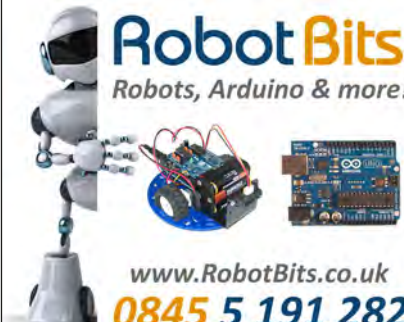

**Robot Bits**  
Robots, Arduino & more!

[www.RobotBits.co.uk](http://www.RobotBits.co.uk)  
**0845 5 191 282**

### CANTERBURY WINDINGS

UK manufacturer of toroidal transformers  
(10VA to 3kVA)

All transformers made to order. No design fees.  
No minimum order.

[www.canterburywindings.co.uk](http://www.canterburywindings.co.uk)

01227 450810

### BTEC ELECTRONICS TECHNICIAN TRAINING

NATIONAL ELECTRONICS  
VCE ADVANCED ICT  
HNC AND HND ELECTRONICS  
FOUNDATION DEGREES  
NVQ ENGINEERING AND IT  
DESIGN AND TECHNOLOGY

LONDON ELECTRONICS COLLEGE  
20 PENYWERN ROAD  
EARLS COURT, LONDON SW5 9SU  
TEL: (020) 7373 8721  
[www.lec.org.uk](http://www.lec.org.uk)

If you would like to advertise on this Classified page then please call

Stewart Kearn on:

**01202 880299**

## ADVERTISERS INDEX

BETA LAYOUT . . . . .	80	QUASAR ELECTRONICS . . . . .	2/3
BRUNNING SOFTWARE . . . . .	59	RK EDUCATION . . . . .	73
COAST ELECTRONICS . . . . .	69	SHERWOOD ELECTRONICS . . . . .	73
CRICKLEWOOD ELECTRONICS . . . . .	66	SPIRATRONICS . . . . .	Cover (ii)
ESR ELECTRONIC COMPONENTS . . . . .	6	STEWART OF READING . . . . .	Cover (iii)
JAYCAR ELECTRONICS . . . . .	4/5	TANDY . . . . .	63
JPG ELECTRONICS . . . . .	80	VARIABLE VOLTAGE TECHNOLOGY . . . . .	27
L-TEK POSCOPE . . . . .	49		
LABCENTER . . . . .	Cover (iv)	<b>ADVERTISEMENT OFFICES:</b> 113 LYNWOOD DRIVE, MERLEY, WIMBORNE, DORSET BH21 1UU <b>PHONE:</b> 01202 880299 <b>FAX:</b> 01202 843233 <b>EMAIL:</b> <a href="mailto:stewart.kearn@wimborne.co.uk">stewart.kearn@wimborne.co.uk</a> <b>WEB:</b> <a href="http://www.epemag.com">www.epemag.com</a>	
LASER BUSINESS SYSTEMS . . . . .	63		
MATRIX MULTIMEDIA . . . . .	37		
MICROCHIP . . . . .	39		
MIKROELEKTRONIKA . . . . .	29		
PEAK ELECTRONIC DESIGN . . . . .	Cover (iii)		
PICO TECHNOLOGY . . . . .	73		

# Next Month

Content may be subject to change

## SemTest – Part 1

Check all those semiconductors in your collection with this fun-to-build tester. How many discrete 'semis' have you got in your collection? Hundreds? Thousands? Are they all good? Don't know? With our new Discrete Semiconductor Test Set you will be able to check a wide range of active components.



## 100W LED Floodlight

LEDs have come a long, long way in recent times. Who would have thought that you could have an LED floodlight with a brightness that rivals the incandescent lamps of yesterday? This compact LED floodlight is efficient, simple to build and cheap!



## Crystal DAC

This new DAC board can be substituted for the original board used in our Hifi Stereo DAC project (Sept-Nov 2011). Its harmonic and intermodulation distortion figures are significantly lower than before. Try it and find out for yourself.

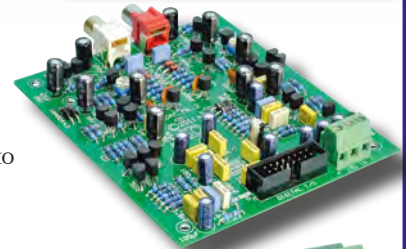

## Simple 1.5A Switching Regulator

This tiny regulator board outputs 1.2V to 20V from a higher voltage DC supply at currents up to 1.5A. It's small, efficient and cheap to build, with many handy features, such as a very low dropout voltage, low heat generation and electronic shutdown.

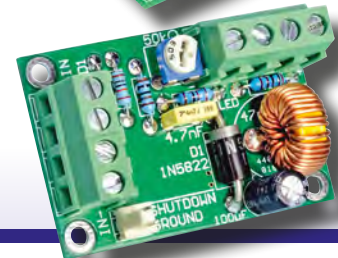

## Jump Start – Logic Probe

Time for a handy digital project – so build a Logic Probe! This is a fun and easy project for all levels of experience. It will be Mike and Richard Tooley's tenth project in our series dedicated to newcomers, or those following courses taught in schools and colleges.

**FEBRUARY '13 ISSUE ON SALE 3 JANUARY 2013**

## Rechargeable Batteries With Solder Tags

NIMH		NICAD	
AA 2000mAh	£2.82	AA 650mAh	£1.41
C 4Ah	£4.70	C 2.5Ah	£3.60
D 9Ah	£7.60	D 4Ah	£4.95
PP3 150mAh	£4.95		

### Instrument case with edge connector and screw terminals

Size 112mm x 52mm x 105mm tall

This box consists of a cream base with a PCB slot, a cover plate to protect your circuit, a black lid with a 12 way edge connector and 12 screw terminals built in (8mm pitch) and 2 screws to hold the lid on. The cream bases have minor marks from dust and handling price £2.00 + VAT(=£2.35) for a sample or £44.00+VAT (=£51.70) for a box of 44.

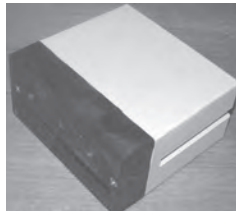

866 battery pack originally intended to be used with an orbitel mobile telephone it contains 10 1.6Ah sub C batteries (42 x 22 dia. the size usually used in cordless screwdrivers etc.) the pack is new and unused and can be broken open quite easily £7.46 + VAT = £8.77



Please add £1.66 + VAT = £1.95 postage & packing per order

## JPG Electronics

Shaws Row, Old Road, Chesterfield, S40 2RB.

Tel 01246 211202 Fax 01246 550959

www.JPGElectronics.com

Mastercard/Visa/Switch

Callers welcome 9.30 a.m. to 5.30 p.m. Monday to Saturday

THE ORIGINAL SINCE 1994

# PCB-POOL

Beta LAYOUT

**Free Stencil**  
Get a free SMD laser stencil with every Prototype order

**WORLD FIRST!**

**FITS-OR-NOT**  
3D PCBs: Hands-on collision check

**Assembly service**  
Even one component possible

**Cool**  
Alu-Core IMS PCBs

Free Phone UK: 0800 389 8560  
sales@pcb-pool.com

PCB-POOL® is a registered trademark of

**www.pcb-pool.com**



UK designed,  
UK made,  
with pride.

Tel. 01298 70012  
www.peakelec.co.uk  
sales@peakelec.co.uk

Atlas House, 2 Kiln Lane  
Harpur Hill Business Park  
Buxton, Derbyshire  
SK17 9JL, UK

Follow us on twitter  
for tips, tricks and  
news.  
@peakatlas

For insured UK delivery:  
Please add £3.00 inc VAT  
to the whole order.  
Check online or  
give us a call for  
overseas pricing.

**PEAK**<sup>®</sup>  
electronic design ltd



## The new *DCA Pro* Pre-Orders Available

As a result of a major product development initiative at Peak Electronic Design Ltd, we are delighted to make this exciting announcement.

**£96.63 + VAT**  
£115.95 inc VAT

The amazing new Atlas *DCA Pro* will be out this December.

- Just connect your component any way round.
- Graphic display shows detailed component schematics.
- Enhanced component identification, pinout identification and analysis.
- USB connectivity for power and communications.
- PC Software included on Peak USB Stick.
- Can be used standalone or with a PC (Win XP or later).
- Curve tracing functions on your PC. (Drive ranges: ±12V / ±15mA).
- Supports Transistors, MOSFETs, JFETs, IGBTs, Diodes, Zeners, LEDs, Voltage Regulators and much more!
- Feature updates online.
- Uses a single Alkaline AAA battery (and/or USB power).

If you pre-order, we will aim to despatch as soon as possible, starting in December 2012. We will immediately acknowledge receipt of your payment and keep you updated with the expected despatch date for your order. You can cancel for a refund at any time.



USB cable included

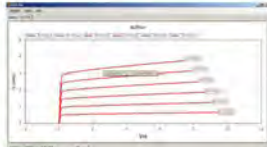

Curve tracing on your PC!

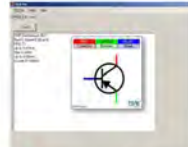

Detailed specs on your PC

It's only possible to show summary specifications here. Please ask if you'd like detailed data. Further information is also available on our website. Product price refunded if you're not happy.

## [www.stewart-of-reading.co.uk](http://www.stewart-of-reading.co.uk)

Check out our website, 1,000's of items in stock.



**HP8560E SPECTRUM ANALYSER**  
30HZ-2.9GHZ with Tracking Generator  
£3,500

**HP8560 SERIES SPECTRUM ANALYSER** Frequency up to 26GHZ  
Various Models from £2,500-£7,000



**HP83731A/B SYNTHESISED SIGNAL GENERATOR**  
1-20GHZ Various Options  
£4,000-5,000



**TEKTRONIX TDS784D**  
4 Channel 1GHz 4GS/S  
Opts 05/1M/2M/2C/3C/4C no Probes  
£2,750

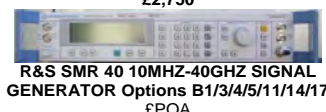

**R&S SMR 40 10MHZ-40GHZ SIGNAL GENERATOR** Options B1/3/4/5/11/14/17  
£POA

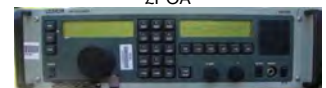

**RACAL 1792 RECEIVER**  
£300

**AGILENT E4402B** Spectrum Analyser 100HZ - 3GHZ with Option 1DN Tracking Gen; 1 DR Narrow Res; A4H GPIB, UKB.....£5800  
**HP 35670A** FFT Dynamic Signal Analyser 2 Channel. Unused in original box...£4000  
**AGILENT 83752B** Synthesised Sweeper 0.01-20GHZ.....£6000  
**HP83711B** Synthesised 1-20GHZ with Opt I/E Attenuator.....£5000  
**AGILENT/HP E4431B** Signal Generator 250KHZ-2GHZ Digital Modulation...£2750  
**MARCONI 2024** Signal Generator 9KHZ-2.4GHZ Opt 04.....£1250  
**MARCONI/IFR 2030** Signal Generator 10KHZ-1.35 GHz.....£995  
**MARCONI 2022E** Synthesised AM/FM Signal Generator 10KHZ-1.01GHZ...£500  
**HP8566A** Spectrum Analyser 100HZ-22GHZ.....£1950  
**HP8568A** Spectrum Analyser 100HZ-1500MHZ.....£1250  
**AVCOM PSA-37D** Spectrum Analyser 1MHZ-4.2GHZ.....£-  
**IFR 1200S** Service Communication Monitor.....£1500  
**HP6624A** Power Supply 0-20V 0-2A Twice, 0-7V 0-5A; 0-50V 0.8A Special price.....£350  
**AVO/MEGGAR FT6/12 AC/DC** breakdown tester.....£400-£600  
**MARCONI/IFR/AEROFLEX 2025** Signal Gen 9KHZ-2.51GHZ Opt 04 High Stab Opt 11 High Power etc As New.....£2500  
**SOLARTRON 1250** Frequency Response Analyser 10uHZ-65KHZ.....£995  
**HP3324A** Synthesised Function Generator 21MHZ.....£500  
**HP41800A** Active Probe 5HZ-500MHZ.....£750  
**ANRITSU MS2601A** Spectrum Analyser 10KHZ-2.2GHZ 50ohm.....£750  
**AGILENT E4421B** 250KHZ-3GHZ Signal Generator.....£2500

**HP53131A** Universal Counter Opt 001 Unused Boxed 3GHZ.....£850  
Unused Boxed 225MHZ.....£595  
Used 225MHZ.....£495  
**HP8569B** Spectrum Analyser 0.01-22GHZ.....£995  
**HP54616C** Oscilloscope Dual Trace 500MHZ 2GS/S Colour.....£1250  
**QUART LOCK 10A-R** Rubidium Frequency Standard.....£1000  
**PENDULUM CNT90** Timer/Counter /Analyser 20GHZ.....£1950  
**ADVANTEST R3465** Spectrum Analyser 9KHZ-8GHZ.....£-  
**HP Programmable Attenuators** £300 each  
**33320H** DC-18GHZ 11db  
**33321G** DC-18GHZ 70db  
Many others available  
**AGILENT E3610A** Power Supply 0-8v 0-3A/0-15v 0-2A Unused  
**AGILENT E3611A** Power Supply 0-20V 0-1.5A/0-35V 0-0.85V Unused  
**HP6269B** Power Supply 0-40V 0-50A.....£400  
**AMPLIFIER RESEARCH** Power Amplifier 1000LAM8.....£POA  
**MARCONI/IFR 2945/A** Radio Communication Test Sets with options.....from £3,000  
**MARCONI 2955/A/B** Radio Communication Test Sets..... from £625  
**MARCONI/IFR 6200/6200B** Microwave Test Set.....£-  
**HP33120A** Function Generator 100 MicroHZ - 15MHZ Unused Boxed.....£595  
Used, No Moulding, No Handle.....£395  
**ENI 3200L** RF Power Amplifier 250KHZ-150MHZ 200W 55Db...£POA  
**CIRRUS CRL254** Sound Level Meter with Calibrator.....£95  
**CEL328** Digital Sound Level Meter with CEL284/2 Acoustical Calibrator.....

### SPECIAL OFFERS

**MARCONI 2305** Modulation Meter.£295  
**MARCONI 6960B** Power Meter with 6910 Sensor 10MHZ-20GHZ.....£295  
**HAMEG 605** Oscilloscope Dual Trace 60MHZ.....£125  
**BLACK STAR 1325** Counter Timer 1.3GHZ.....£95  
**HP8484A** Power Sensor 0.01-18GHZ 0.3nW-10uW.....£125



**ANRITSU 54169A**  
Scaler Network Analyser 0.01-40GHZ £POA

**ANRITSU 37247C**  
Vector Network Analyser 0.04-20GHZ £POA

Many Accessories with each unit

**FLUKE SCOPEMETERS 99B** Series II 2Ch 100MHZ 5GS/G..... from £325  
**97** 2Ch 50MHZ 25MS/S..... from £225

### STEWART OF READING

17A King Street, Mortimer,  
Near Reading RG7 3RS  
Telephone: 0118 933 1111  
Fax: 0118 933 2375  
9am - 5pm Monday - Friday

Used Equipment - **GUARANTEED**  
Prices plus Carriage and VAT

Please check availability before ordering or **CALLING IN**

# CAD CONNECTED

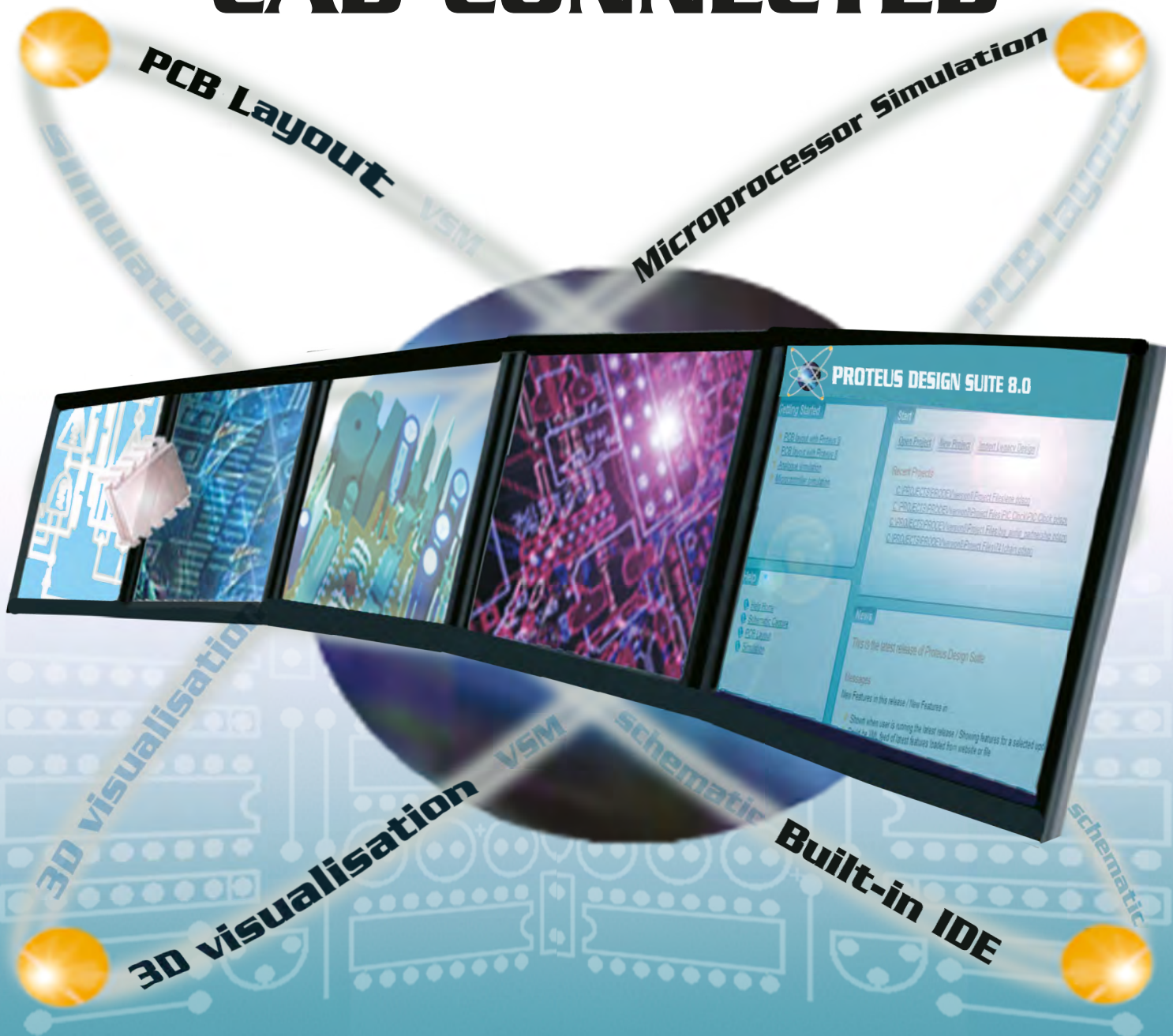

## PROTEUS DESIGN SUITE VERSION 8

Featuring a brand new application framework, common parts database, live netlist and 3D visualisation, a built in debugging environment and a WYSIWYG Bill of Materials module, Proteus 8 is our most integrated and easy to use design system ever. Other features include:

- Hardware Accelerated Performance.
- Unique Thru-View™ Board Transparency.
- Over 35k Schematic & PCB library parts.
- Integrated Shape Based Auto-router.
- Flexible Design Rule Management.
- Polygonal and Split Power Plane Support.
- Board Autoplacement & Gateswap Optimiser.
- Direct CAD/CAM, ODB++, IDF & PDF Output.
- Integrated 3D Viewer with 3DS and DXF export.
- Mixed Mode SPICE Simulation Engine.
- Co-Simulation of PIC, AVR, 8051 and ARM MCUs.
- Direct Technical Support at no additional cost.

**labcenter**  [www.labcenter.com](http://www.labcenter.com)  
**Electronics**

Labcenter Electronics Ltd. 21 Hardy Grange, Grassington, North Yorks. BD23 5AJ.  
Registered in England 4692454 Tel: +44 (0)1756 753440, Email: [info@labcenter.com](mailto:info@labcenter.com)

Visit our website or  
phone 01756 753440  
for more details