

THE No 1 UK MAGAZINE FOR ELECTRONICS TECHNOLOGY & COMPUTER PROJECTS

EPE EVERYDAY PRACTICAL ELECTRONICS

www.epemag.com

SOFTSTARTER

TAME THE 'SPLAT' AT SWITCH-ON!

6-DECADE RESISTANCE BOX

**A MILLION PRECISE
VALUES TO FINE TUNE
YOUR DESIGNS**

SEMTEST – PART 3

**BUILD AND USE OUR ULTIMATE
SILICON CHECKER**

Jump Start

**Egg Timer – eggcellent breakfast, timed
to perfection!**



**INTERFACE, NET WORK, CIRCUIT SURGERY, READOUT,
TECHNO TALK, PIC N' MIX**

**WIN A
MICROCHIP
mTouch AR1000
Development
Kit**

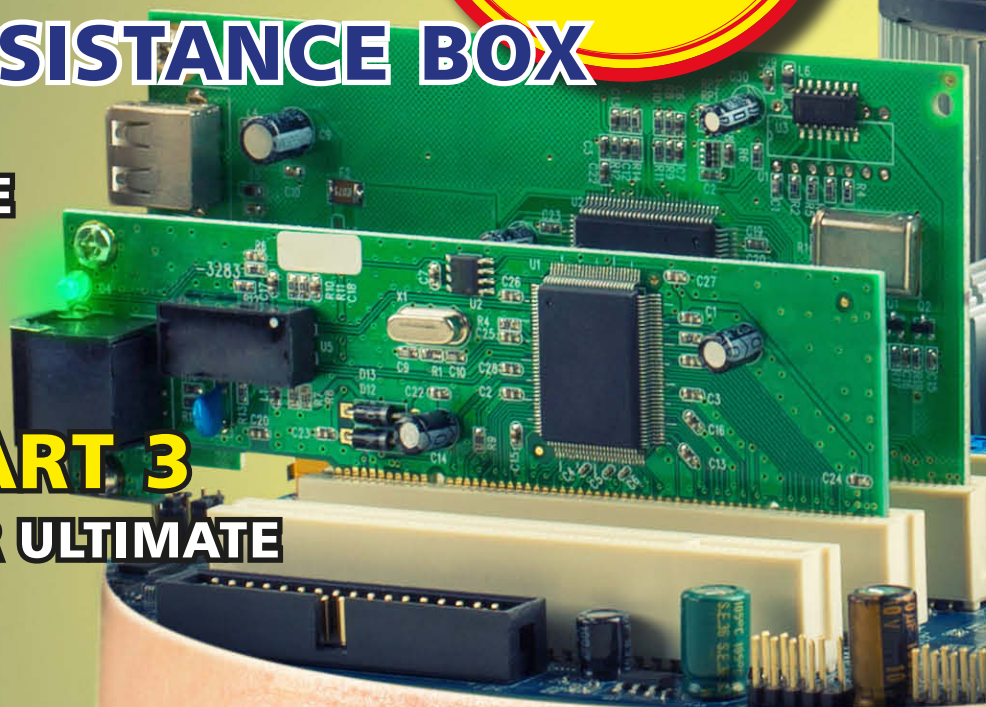

APRIL 2013 £4.40



Crystal-free 8-bit USB PIC® microcontrollers cut system costs and power consumption

0.25% clock accuracy enables USB connectivity, eliminating the need for external crystal



Microchip's lowest-cost and smallest-form-factor USB microcontrollers (MCUs), feature pin counts of 14 to 100 pins and are the first 8-bit MCUs to integrate LCD control, battery-backed RTCC, and USB on a single chip.

Microchip's latest USB PIC® MCUs feature internal clock sources with 0.25% clock accuracy to enable USB connectivity with no external crystal. They are also the first USB MCUs to combine pin-counts ranging from 14 to 100, with high peripheral integration and up to 128 KB of Flash. The eXtreme Low Power (XLP) technology also keeps power consumption down to 35 μ A/MHz in active mode and 20 nA in sleep mode.

Lowest-cost and smallest-form-factor

The PIC16F145X MCUs give you USB connectivity and capacitive touch sensing, in addition to a wide range of integrated peripherals with footprints down to 4x4 mm.

High-performance touch-sensing with USB

With an integrated Charge Time Measurement Unit (CTMU) and 1.8 V to 5 V operation, PIC18F2X/4XK50 MCUs are pin-compatible with legacy PIC18 MCUs, giving an easy migration to higher-performance.

USB plus LCD control and a RTCC with Vbat

The PIC18F97J94 family gives you USB connectivity with LCD control, and a battery-backed real-time clock calendar (RTCC), all on a single 8-bit PIC® microcontroller.

GET STARTED IN 3 EASY STEPS:

1. Choose a peripheral mix and pin count to suit your application
2. Use the free USB stacks and software drivers for faster design
3. Start developing with low-cost development kits

For more information, go to: www.microchip.com/get/eu8bitUSB



Microcontrollers • Digital Signal Controllers • Analog • Memory • Wireless

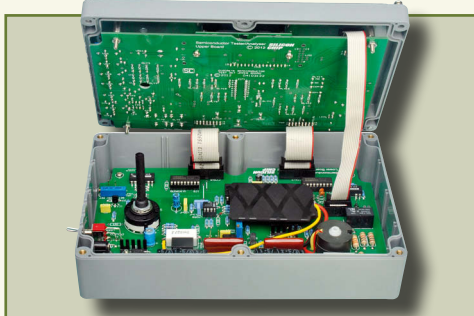
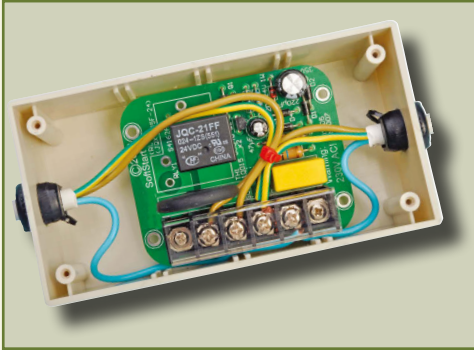

© Wimborne Publishing Ltd 2013. Copyright in all drawings, photographs and articles published in *EVERYDAY PRACTICAL ELECTRONICS* is fully protected, and reproduction or imitations in whole or in part are expressly forbidden.

Our May 2013 issue will be published on Thursday 4 April 2013, see page 72 for details.

Everyday Practical Electronics, April 2013

Projects and Circuits

- SOFTSTARTER** 10
 by Nicholas Vinen
 Tame nasty surge currents without affecting appliance performance
- 6-DECADE RESISTANCE SUBSTITUTION BOX** 20
 By Jim Rowe
 Select from thousands of different resistor values between 10Ω and 10MΩ
- SEMTEST – PART 3** 26
 by Jim Rowe
 Construction and set-up procedure, plus adding a crowbar safety circuit

Series and Features

- TECHNO TALK** by Mark Nelson 24
 When electronics go bad
- JUMP START** by Mike and Richard Tooley 40
 Egg Timer
- MAX'S COOL BEANS** by Max The Magnificent 47
 A bright future
- PIC N' MIX** by Mike Hibbett 49
 Time ticks by
- CIRCUIT SURGERY** by Ian Bell 52
 Op amp bandwidth
- INTERFACE** by Robert Penfold 55
 USB supply problems
- NET WORK** by Alan Winstanley 65
 YouView, iPlayer... More Wi-Fi woes

Regulars and Services

- EDITORIAL** 7
 Powering circuits mechanically
- NEWS** – Barry Fox highlights technology's leading edge 8
 Plus everyday news from the world of electronics
- MICROCHIP READER OFFER** 19
EPE Exclusive – Win one of two Microchip mTouch AR1000 Development Kits
- SUBSCRIBE TO *EPE*** and save money 25
- PIC PROJECTS CD-ROM VOLUME 1** 38
- EPE* BACK ISSUES** Did you miss these? 48
- PIC PROJECTS CD-ROM VOLUME 2** 58
- READOUT** – Matt Pulzer addresses general points arising 60
- CD-ROMS FOR ELECTRONICS** 62
 A wide range of CD-ROMs for hobbyists, students and engineers
- DIRECT BOOK SERVICE** 67
 A wide range of technical books available by mail order, plus more CD-ROMs
- EPE* PCB SERVICE** 70
 PCBs for *EPE* projects
- ADVERTISERS INDEX** 71
- NEXT MONTH!** – Highlights of next month's *EPE* 72

PIC & ATMEL Programmers

We have a wide range of low cost PIC and ATMEL Programmers. Complete range and documentation available from our web site.

Programmer Accessories:

40-pin Wide ZIF socket (ZIF40W) £14.95
18Vdc Power supply (PSU121) £22.95
Leads: Parallel (LDC136) £3.95 / Serial (LDC441) £3.95 / USB (LDC644) £2.95

USB & Serial Port PIC Programmer

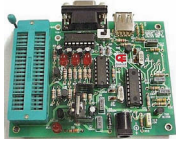

USB/Serial connection. Header cable for ICSP. Free Windows XP software. See website for PICs supported. ZIF Socket and USB lead extra. 18Vdc.

Kit Order Code: 3149EKT - £49.95
Assembled Order Code: AS3149E - £64.95
Assembled with ZIF socket Order Code: AS3149EZIF - £74.95

USB Flash PIC Programmer

USB PIC programmer for a wide range of Flash devices—see website for details. Free Windows Software. ZIF Socket and USB lead not included. Powered via USB port - no external power supply required.



Assembled with ZIF socket Order Code: AS3150ZIF - £64.95

ATMEL 89xxxx Programmer



Uses serial port and any standard terminal comms program. 4 LED's display the status. ZIF sockets not included. Supply: 16Vdc.

Kit Order Code: 3123KT - £28.95
Assembled Order Code: AS3123 - £39.95

Introduction to PIC Programming

Go from complete beginner to burning a PIC and writing code in no time! Includes 49 page step-by-step PDF Tutorial Manual, Programming Hardware (with LED test section), Win 3.11—XP Programming Software (Program, Read, Verify & Erase), and 1 rewritable PIC16F84A that you can use with different code (4 detailed examples provided for you to learn from). PC parallel port.
Kit Order Code: 3081KT - £16.95
Assembled Order Code: AS3081 - £24.95



PIC Programmer Board

Low cost PIC programmer board supporting a wide range of Microchip® PIC™ microcontrollers. Requires PC serial port. Windows interface supplied.



Kit Order Code: K8076KT - £34.95

PIC Programmer & Experimenter Board

The PIC Programmer & Experimenter Board with test buttons and LED indicators to carry out educational experiments, such as the supplied programming examples. Includes a 16F627 Flash Microcontroller that can be reprogrammed up to 1000 times for experimenting at will. Software to compile and program your source code is included.
Kit Order Code: K8048KT - £34.95
Assembled Order Code: VM111 - £44.95



Controllers & Loggers

Here are just a few of the controller and data acquisition and control units we have. See website for full details. 12Vdc PSU for all units: Order Code PSU446 £8.95

USB Experiment Interface Board

5 digital input channels and 8 digital output channels plus two analogue inputs and two analogue outputs with 8 bit resolution.



Kit Order Code: K8055NKT - £29.95
Assembled Order Code: VM110N - £43.95

Rolling Code 4-Channel UHF Remote

State-of-the-Art. High security. 4 channels. Momentary or latching relay output. Range up to 40m. Up to 15 Tx's can be learnt by one Rx (kit includes one Tx but more available separately). 4 indicator LED's. Rx: PCB 77x85mm, 12Vdc/6mA (standby). Two & Ten Channel versions also available.



Kit Order Code: 3180KT - £54.95
Assembled Order Code: AS3180 - £64.95

Computer Temperature Data Logger

Serial port 4-channel temperature logger. °C or °F. Continuously logs up to 4 separate sensors located 200m+ from board. Wide range of tree software applications for storing/using data. PCB just 45x45mm. Powered by PC. Includes one DS1820 sensor.
Kit Order Code: 3145KT - £19.95
Assembled Order Code: AS3145 - £26.95
Additional DS1820 Sensors - £4.95 each



Remote Control Via GSM Mobile Phone

Place next to a mobile phone (not included). Allows toggle or auto-timer control of 3A mains rated output relay from any location with GSM coverage.



Kit Order Code: MK160KT - £11.95

Most items are available in kit form (KT suffix) or pre-assembled and ready for use (AS prefix).

4-Ch DTMF Telephone Relay Switcher

Call your phone number using a DTMF phone from anywhere in the world and remotely turn on/off any of the 4 relays as desired. User settable Security Password, Anti-Tamper, Rings to Answer, Auto Hang-up and Lockout. Includes plastic case. 130 x 110 x 30mm. Power: 12Vdc.
Kit Order Code: 3140KT - £79.95
Assembled Order Code: AS3140 - £94.95



8-Ch Serial Port Isolated I/O Relay Module

Computer controlled 8 channel relay board. 5A mains rated relay outputs and 4 opto-isolated digital inputs (for monitoring switch states, etc). Useful in a variety of control and sensing applications. Programmed via serial port (use our new Windows interface, terminal emulator or batch files). Serial cable can be up to 35m long. Includes plastic case 130x100x30mm. Power: 12Vdc/500mA.
Kit Order Code: 3108KT - £74.95
Assembled Order Code: AS3108 - £89.95

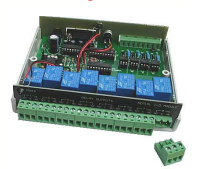

Infrared RC 12-Channel Relay Board

Control 12 onboard relays with included infrared remote control unit. Toggle or momentary. 15m+ range. 112 x 122mm. Supply: 12Vdc/0.5A
Kit Order Code: 3142KT - £64.95
Assembled Order Code: AS3142 - £74.95



Audio DTMF Decoder and Display

Detect DTMF tones from tape recorders, receivers, two-way radios, etc using the built-in mic or direct from the phone line. Characters are displayed on a 16 character display as they are received and up to 32 numbers can be displayed by scrolling the display. All data written to the LCD is also sent to a serial output for connection to a computer. Supply: 9-12V DC (Order Code PSU303). Main PCB: 55x95mm.
Kit Order Code: 3153KT - £37.95
Assembled Order Code: AS3153 - £49.95



3x5Amp RGB LED Controller with RS232

3 independent high power channels. Preprogrammed or user-editable light sequences. Standalone option and 2-wire serial interface for microcontroller or PC communication with simple command set. Suitable for common anode RGB LED strips, LEDs and incandescent bulbs. 56 x 39 x 20mm. 12A total max. Supply: 12Vdc.
Kit Order Code: 8191KT - £29.95
Assembled Order Code: AS8191 - £39.95

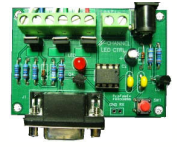

Hot New Products!

Here are a few of the most recent products added to our range. See website or join our email Newsletter for all the latest news.

4-Channel Serial Port Temperature Monitor & Controller Relay Board

4 channel computer serial port temperature monitor and relay controller with four inputs for Dallas DS18S20 or DS18B20 digital thermometer sensors (£3.95 each). Four 5A rated relay channels provide output control. Relays are independent of sensor channels, allowing flexibility to setup the linkage in any way you choose. Commands for reading temperature and relay control sent via the RS232 interface using simple text strings. Control using a simple terminal / comms program (Windows HyperTerminal) or our free Windows application software. Kit Order Code: 3190KT - **£84.95**
Assembled Order Code: AS3190 - **£99.95**



40 Second Message Recorder

Feature packed non-volatile 40 second multi-message sound recorder module using a high quality Winbond sound recorder IC. Stand-alone operation using just six onboard buttons or use onboard SPI interface. Record using built-in microphone or external line in. 8-24 Vdc operation. Just change one resistor for different recording duration/sound quality. sampling frequency 4-12 kHz. Kit Order Code: 3188KT - **£29.95**
Assembled Order Code: AS3188 - **£37.95**
120 second version also available



Bipolar Stepper Motor Chopper Driver

Get better performance from your stepper motors with this dual full bridge motor driver based on SGS Thompson chips L297 & L298. Motor current for each phase set using on-board potentiometer. Rated to handle motor winding currents up to 2 Amps per phase. Operates on 9-36Vdc supply voltage. Provides all basic motor controls including full or half stepping of bipolar steppers and direction control. Allows multiple driver synchronisation. Perfect for desktop CNC applications. Kit Order Code: 3187KT - **£39.95**
Assembled Order Code: AS3187 - **£49.95**



Video Signal Cleaner

Digitally cleans the video signal and removes unwanted distortion in video signal. In addition it stabilises picture quality and luminance fluctuations. You will also benefit from improved picture quality on LCD monitors or projectors. Kit Order Code: K8036KT - **£29.95**
Assembled Order Code: VM106 - **£44.95**



Most items are available in kit form (KT suffix) or assembled and ready for use (AS prefix).

Motor Speed Controllers

Here are just a few of our controller and driver modules for AC, DC, Unipolar/Bipolar stepper motors and servo motors. See website for full details.

DC Motor Speed Controller (100V/7.5A)

Control the speed of almost any common DC motor rated up to 100V/7.5A. Pulse width modulation output for maximum motor torque at all speeds. Supply: 5-15Vdc. Box supplied. Dimensions (mm): 60Wx100Lx60H. Kit Order Code: 3067KT - **£19.95**
Assembled Order Code: AS3067 - **£27.95**



Bidirectional DC Motor Speed Controller

Control the speed of most common DC motors (rated up to 32Vdc/10A) in both the forward and reverse direction. The range of control is from fully OFF to fully ON in both directions. The direction and speed are controlled using a single potentiometer. Screw terminal block for connections. Kit Order Code: 3166v2KT - **£23.95**
Assembled Order Code: AS3166v2 - **£33.95**

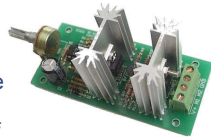

Computer Controlled / Standalone Unipolar Stepper Motor Driver

Drives any 5-35Vdc 5, 6 or 8-lead unipolar stepper motor rated up to 6 Amps. Provides speed and direction control. Operates in stand-alone or PC-controlled mode for CNC use. Connect up to six 3179 driver boards to a single parallel port. Board supply: 9Vdc. PCB: 80x50mm. Kit Order Code: 3179KT - **£17.95**
Assembled Order Code: AS3179 - **£24.95**



Computer Controlled Bi-Polar Stepper Motor Driver

Drive any 5-50Vdc, 5 Amp bi-polar stepper motor using externally supplied 5V levels for STEP and DIRECTION control. Opto-isolated inputs make it ideal for CNC applications using a PC running suitable software. Board supply: 8-30Vdc. PCB: 75x85mm. Kit Order Code: 3158KT - **£24.95**
Assembled Order Code: AS3158 - **£34.95**



AC Motor Speed Controller (600W)

Reliable and simple to install project that allows you to adjust the speed of an electric drill or 230V AC single phase induction motor rated up to 600 Watts. Simply turn the potentiometer to adjust the motors RPM. PCB: 48x65mm. Not suitable for use with brushless AC motors. Kit Order Code: 1074KT - **£15.95**
Assembled Order Code: AS1074 - **£23.95**



See www.quasarelectronics.com for lots more DC, AC and Stepper motor drivers



QUASAR
electronics
The Electronic Kit Specialists Since 1993

Credit Card Sales
01279 467 799

Electronic Project Labs

Great introduction to the world of electronics. Ideal gift for budding electronics expert!

500-in-1 Electronic Project Lab

Top of the range. Complete self-contained electronics course. Takes you from beginner to 'A' Level standard and beyond! Contains all the hardware and manuals to assemble 500 projects. You get 3 comprehensive course books (total 368 pages) - *Hardware Entry Course*, *Hardware Advanced Course* and a microprocessor based *Software Programming Course*. Each book has individual circuit explanations, schematic and connection diagrams. Suitable for age 12+. Order Code EPL500 - **£179.95**
Also available: 30-in-1 £17.95, 50-in-1 £29.95, 75-in-1 £39.95 £130-in-1 £49.95 & 300-in-1 £79.95 (see website for details)



Tools & Test Equipment

We stock an extensive range of soldering tools, test equipment, power supplies, inverters & much more - please visit website to see our full range of products.

Advanced Personal Scope 2 x 240MS/s

Features 2 input channels - high contrast LCD with white backlight - full auto set-up for volt/div and time/div - recorder roll mode, up to 170h per screen - trigger mode: run - normal - once - roll ... - adjustable trigger level and slope and much more. Order Code: APS230 - ~~£499.95~~ **£394.95**



Personal Scope 10MS/s

The Personal Scope is not a graphical multimeter but a complete portable oscilloscope at the size and the cost of a good multimeter. Its high sensitivity - down to 0.1mV/div - and extended scope functions make this unit ideal for hobby, service, automotive and development purposes. Because of its exceptional value for money, the Personal Scope is well suited for educational use. Order Code: HPS10 - ~~£189.95~~ **£139.95**
See website for more super deals!



www.quasarelectronics.com

Secure Online Ordering Facilities • Full Product Listing, Descriptions & Photos • Kit Documentation & Software Downloads

Featured Kits in

Everyday Practical Electronics

April 2013



Everyday Practical Electronics Magazine has been publishing a series of popular kits by the acclaimed Silicon Chip Magazine Australia. These projects are 'bullet proof' and already tested Down Under. All Jaycar kits are supplied with specified board components, quality fibreglass tinned PCBs and have clear English instructions. Watch this space for future featured kits.

High-Power Class-D Audio Amplifier Kit

High quality amplifier boasting 250WRMS output into 4 ohms, 150W into 8 ohms and can be bridged with a second kit for 450W into 8 ohms. Features include high efficiency (90% @ 4 ohm), low distortion and noise (<0.01%), and over-current, over-temperature, under-voltage, over-voltage and DC offset protection. Kit supplied with double sided, soldermasked and screen-printed silk-screened PCB with SMD IC pre-soldered, heatsink, and electronic circuit board mounted components.



£32.75*

• Power requirements: -57V/0/+57V use KC-5517
• S/N ratio: 103dB
• Freq. response: 10Hz - 10kHz, +/- 1dB
• PCB: 117 x 167mm

Cat. KC-5514

Also available:

Stereo Speaker Protector Kit to suit **KC-5515 £11.00**
+/- 57V Power Supply Kit to suit **KC-5517 £11.00**

Garbage and Recycling Reminder Kit

Easy to build kit that reminds you when to put which bin out by flashing the corresponding brightly coloured LED. Up to four bins can be individually set to weekly, fortnightly or alternate week or fortnight cycle. Kit supplied with silk-screened PCB, black enclosure (83 x 54 x 31mm), pre-programmed PIC, battery and PCB mount components.



£11.00*

• PCB: 75 x 47mm
Cat. KC-5518

Measure Water Level

Ultrasonic Water Tank Level Indicator Kit

Designed for plastic and concrete tanks, or steel tanks with modification, this water level indicator kit uses an ultrasonic assembly that mounts inside the tank and a microprocessor controlled meter to display the water level. Selectable between 10 LED Bargraph or 19 level Dot mode. Easy to calibrate, can be pushbutton or permanent display, powered by a 9V battery or power adaptor (available separately). Kit includes PCB, waterproof case and all electronic components. Silicon sealant not included.



£27.25*

• Suits tanks up to 2.4m high
• PCB: 104 x 78.5mm
Cat. KC-5503

miniMaximite Controller Kit

A versatile and intelligent controller to interface with your creations, such as home automation. Features 20 configurable digital/analog I/O ports, 128K RAM and 256KB flash memory to hold your program and data. Design and test in MMBasic over a USB link from your PC, then disconnect the PC and the programs continue to operate. Alternatively, hard wire a PC monitor, keyboard, SD card reader and amplified speaker to work independent of a PC.



£18.25*

- Requires 2.3 - 3.6VDC (2 x AA or use plugpack **MP-3310 £7.00**)
- Kit supplied with PCB, pre-programmed and pre-soldered micro, and electronic components
- PCB: 78 x 38mm

Cat. KC-5505

ALL SMD COMPONENTS PRE-SOLDERED ON BOARD

Simple 1.5A Switching Regulator Kit

Outputs 1.2 to 20V from a higher voltage DC supply at currents up to 1.5A. It is small, efficient and with many features including a very low drop-out voltage, little heat generation, electronic shutdown, soft start, thermal, overload and short circuit protection. Kit supplied with PCB, pre-soldered surface mounted components.

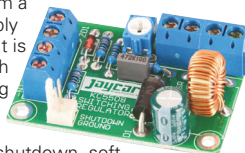

£14.50*

- PCB: 49.5 x 34mm

Cat. KC-5508

Featured in EPE February 2013

Theremin Synthesiser Kit MkII

Create your own eerie science fiction sound effects by simply moving your hand near the antenna. Easy to set up and build. Complete kit contains PCB with overlay, pre-machined case and all specified components.



£27.25*

- PCB: 85 x 145mm

Cat. KC-5475

Featured in EPE March 2011

High Energy Ignition Kit for Cars

Use this kit to replace a failed ignition module or to upgrade a mechanical ignition system when restoring a vehicle. Use with virtually any ignition system that uses a single coil with points, hall effect/lumenation, retractor or optical sensors (Crane and Piranha) and ECU. Features include adjustable dwell time, output or follow input option, tachometer output, adjustable debounce period, dwell compensation for battery voltage and coil switch-off with no trigger signal.

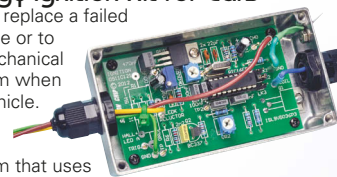

£18.25*

- Kit supplied with silk-screened PCB, diecast enclosure (111 x 60 x 30mm), pre-programmed PIC and PCB mount components for four trigger/pickup options

Cat. KC-5513

Ultrasonic Antifouling for Boats

Marine growth electronic antifouling systems can cost thousands. This project uses the same ultrasonic waveforms and virtually identical ultrasonic transducers mounted in a sturdy polyurethane housings. By building it yourself you save a fortune! Standard unit consists of control electronic kit and case, ultrasonic transducer, potting and gluing components and housings. The single transducer design of this kit is suitable for boats up to 10m (32ft; boats longer than about 14m will need two transducers and drivers. Basically all parts supplied in the project kit including wiring. Price includes epoxies.



Now includes pre-built transducer at no extra cost

- 12VDC
- Suitable for power or sail
- Could be powered by a solar panel/wind generator
- PCB: 104 x 78mm

£90.50*

Cat. KC-5498

Featured in EPE September/October 2012

PIC Based Water Tank Level Meter Kit

This PIC-based unit uses a pressure sensor to monitor water level and will display tank level via an RGB LED at the press of a button. The kit can be expanded to include an optional wireless remote display panel that can monitor up to ten separate tanks or you can add a wireless remote controlled mains power switch (**KC-5462 £36.25** available separately) to control remote water pumps.

- Kit includes electronic components, case, screen printed PCB and pressure sensor

Cat. KC-5460

Featured in EPE May 2010

£39.50*

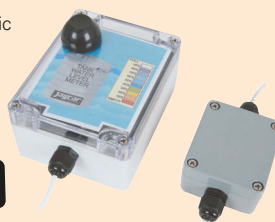

YS-5600

YS-5602

Also Available Pre-built:
Dual output, suitable for vessels up to 14m (45ft) YS-5600 £309.25*
Quad output, suitable for vessels up to 20m (65ft) YS-5602 £412.25*

Jaycar
Electronics

Better, More Technical

For more details on each kit visit our website www.jaycar.co.uk

FREE CALL ORDERS: 0800 032 7241

Don't Just Sit There... Build Something!

Test & Measurement Kits for Electronic Enthusiasts

Data Hold DMM with Backlight

A handy digital multimeter with lots of features at a great price. Has all the features you would expect including holster and probes included. See online for more info.

£5.25*

- 2000 count
- DC & AC voltage
- Transistor & Diode test
- 10A DC current
- Size: 145(L) x 65(W) x 35(H)mm

Cat. QM-1523



Digital Multimeter Kit

Learn everything there is to know about component recognition and basic electronics with this comprehensive kit. From test leads to solder, everything you need for the construction of this meter is included.

- Size: 67(W) x 123(H) x 25(D)mm

Cat. KG-9250

£9.00*



Low Capacitance Adaptor for DMM Kit

Many modern multimeters come with capacitance ranges, but they're no good for very small values. This kit is a nifty little adaptor that allows a standard digital multimeter to measure very low values of capacitance from less than one picofarad to over 10nF. It will allow you to measure tiny capacitors or stray capacitances in switches, connectors and wiring. The kit is complete with PCB, components and case. All you'll need is a 9V battery and just about any modern DMM.

- PCB: 51 x 90mm

Cat. KC-5493

£12.75*



Transistor Tester Kit

Have you ever unsoldered a suspect transistor only to find that it checks OK? Troubleshooting exercises are often hindered by this type of false alarm. You can avoid these hassles with the In-Circuit Transistor, SCR and Diode Tester. The kit does just that, test drives WITHOUT the need to unsolder them from the circuit! VERY HANDY!

Cat. KA-1119

£10.25*



USB Power Monitor Kit

Plug this kit inline with a USB device to display the current that is drawn at any given time. Check the total power draw from an unpowered hub and its attached devices or what impact a USB device has on your laptop battery life. Displays current, voltage or power, is auto-ranging and will read as low as a few microamps and up to over an amp. Kit supplied with double sided, soldermasked and screen-printed PCB with SMD components presoldered, LCD screen, and components.

- PCB: 65 x 36mm

Cat. KC-5516

£21.75*



Laptop not included

DC Relay Switch Kit

An extremely useful and versatile kit that enables you to use a tiny trigger current - as low as 400µA at 12V to switch up to 30A at 50VDC. It has an isolated input and is suitable for a variety of triggering options. Kit includes PCB with overlay and all electronic components with clear instructions.

Cat. KC-5434

£6.25*



12/24VDC 20A Motor Speed Controller Kit

Control the speed of 12 or 24VDC motors from zero to full power, up to 20A. Features optional soft start, adjustable pulse frequency to reduce motor noise, and low battery protection. The speed is set using the onboard trimpot, or by using an external potentiometer (available separately, use RP-3510).

- Kit supplied with PCB and all onboard electronic components
- Suitable enclosure UB3 case, HB-6013 sold separately

Cat. KC-5502

£14.50*

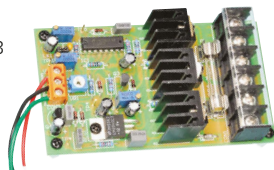

Jacob's Ladder MK3

A spectacular rising ladder of bright and noisy sparks for theatre special effects or to impress your friends. This improved circuit has even more zing and zap than it's previous design from April 2007 and requires the purchase of a 12V ignition coil (available from auto stores and parts recyclers).

- Kit supplied with silk-screened PCB, diecast enclosure (111 x 60 x 30mm), pre-programmed PIC, PCB mount components and pre-cut wire/ladder.
- Powered from a 12V 7Ah SLA or 12V car battery.

Cat. KC-5520

£18.25*

Battery not included

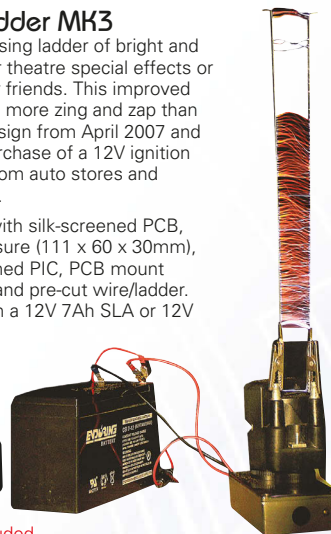

'The Champion' Audio Amplifier Kit with Pre-Amplifier

Suitable for general-purpose audio projects and supports microphone and electric guitar input. It uses the AN7511 audio IC to deliver 2W music power into 8 ohms from a 9 to 12V supply. Features low distortion, two inputs (mixed 1:1), mute and standby control. Power from 4 - 13.5VDC. See website for specifications.

- Kit supplied with silk-screened PCB, heatsink and PCB mount components
- PCB: 101x41mm

Cat. KC-5519

£7.25*



HOW TO ORDER

PHONE: 0800 032 7241*
 FAX: +61 2 8832 3118*
 EMAIL: techstore@jaycar.co.uk
 POST: P.O. Box 107, Rydalmere NSW 2116 Australia

NOW SHIPPING VIA DHL

5 - 10 day working delivery
 • FAST DELIVERY • TRACK SHIPMENT

*Australian Eastern Standard Time (Monday - Friday 09.00 to 17.30 GMT + 11 hours)
 *UK Greenwich Mean Time (Monday - Friday 23.00 to 07.30)
 *All prices in Pounds Sterling. Prices valid until 31/03/2013

***ALL PRICES EXCLUDE POSTAGE & PACKING**



Liquid Level Sensor Kit

When two contacts are shorted by liquid, an LED will illuminate. Use in applications such as an overflow alarm and rain detector. Connect Relay Card (KG-9142 £3.75 available separately) for a relay output to operate lights, sirens or other warning devices.

- Project requires 9VDC
- PCB size: 28 x 17mm
- Kit supplied with Kwik Kit PCB and all electronic components

Cat. KG-9138

£3.75*

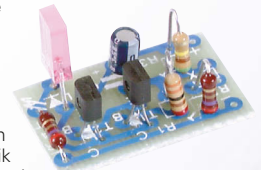

Arduino Corner

Arduino Experimenters Kit

Servo motor, lights, buttons, switches, sound, sensors, breadboard, wires and more are included with a Freertronics Eleven Arduino compatible board in this extensive hobby experimenter and starter kit.

£32.75*

- Comprehensive instructions included
- Size: 340(W) x 165(H) x 36(D)mm

Cat. XC-4262

Getting Started with Arduino Book 2nd Edition

This book is aimed for the first timer and explains what Arduino is, how it works, and what you can do with it.

- Soft cover, 128 pages.
216 x 140mm

Cat. BM-7131

£9.75*

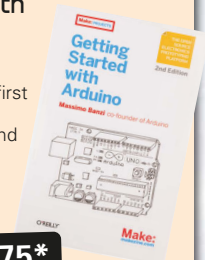

Practical Arduino

A much larger and detailed book. It takes you beyond basics quite quickly and shows you how to make up a typical application/design.

- Soft cover, 422 pages.
235 x 190mm

Cat. BM-7132

£18.00*



ORDER ONLINE: www.jaycar.co.uk

Jaycar
Electronics

Better, More Technical

Don't Just Sit There...Build Something!

UK's No 1 source for VELLEMAN® Kits
Kit Catalogue Available
Self Assembly Kits & Ready made Modules - See our web site for details on the whole range, Data sheets, Software and more.
www.esr.co.uk
Now Available - Cebek Modules
All modules assembled & tested.
Digital Echo Chamber Kit
 A compact sound effects kit, with built-in mic or line in, line out or speaker (500mW). 4 Adjustment controls. Power: 9Vdc 150mA

MK182 Velleman kit £11.43
3rd Brake Light Flasher Kit
 Works with any incandescent or LED rear centre brake light. Flashes at 7Hz for 5 or 10 times, adjustable re-triggering. Power: 12Vdc max load 4A

MK178 Velleman kit £6.30
Digital Clock Mini Kit
 Red 7 Segment display in attractive enclosure, automatic time base selection, battery back-up, 12 or 24Hr modes. Power: 9Vac or dc

MK151 Velleman kit £15.09
Proximity Card Reader Kit
 A simple security kit with many applications. RFID technology activates a relay, either on/off or timed. Supplied with 2 cards, can be used with up to 25 cards. Power: 9Vac or dc

MK179 Velleman kit £14.25
Running Microbug Kit
 Powered by two subminiature motors, this robot will run towards any light source. Novel shape PCB with LED eyes. Power: 2 x AAA Batteries

MK127 Velleman kit £9.02
200W Power Amplifier
 A high quality audio power amp, 200W music power @ 4Ω 3-200kHz Available as a kit without heatsink or module including heatsink. **K8060 Velleman kit £12.85**
Heatsink for kit £9.95
VM100 Module £38.54

Multifunction Up/Down Counter
 An up or down counter via on-board button or ext input. Time display feature. Alarm count output. 0-9999 display. Power: 9-12Vdc 150mA

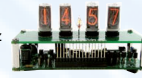
K8035 Velleman kit £17.85
Nixie Clock Kit
 Gas filled nixie tubes with their distinctive orange glow. HH:MM display, automatic power sync 50/60Hz. Power: 9-12Vac 300mA

K8099 Velleman kit £64.96
Mini USB Interface Board
 New from Velleman this little interface module with 15 inputs/outputs inc digital & analogue in, PWM outputs. USB Powered 50mA, Software supplied

VM167 Module £26.80
Thermostat Mini Kit
 General purpose low cost thermostat kit. +5 to +30°C Easily modified temperature range/min/max/hysteresis 3A Relay. Power: 12Vdc 100mA

MK138 Velleman Kit £4.55
Velleman Function Generator
 PC Based USB controlled function generator. 0.01Hz to 2Mhz Pre-defined & waveform editor. Software supplied. See web site for full feature list.

PCGU1000 Velleman £118.38
Digital Record/Player
 Non volatile flash memory, Single 20 sec recording via integral mic, 2W output to 8Ω speaker. Power: 5Vdc 100mA

C-9701 Cebek Module £7.89
2 Digital Counter
 Standard counter, 0 to 99 from input pulses or external signal. With reset input, 13.5mm Displays. Power: 12Vdc 90mA.

CD-9 Cebek Module £12.99
1.8W Mono Amplifier
 Compact mono 1.8W RMS 4Ω power stage, short circuit & reverse polarity protection. 30-18kHz, Power: 4-14Vdc 150mA

E-1 Cebek Module £5.87
20W 2 Channel Amplifier
 Mono amplifier with 2 channels (Low & High frequency), 20W RMS 4Ω per channel, adjustable high level. 22-22kHz, short circuit & reverse polarity protection. Power: 8-18Vdc 2A

E-14 Cebek Module £22.11
5W Stereo Amplifier
 Stereo power stage with 5W RMS 4Ω, 30-18kHz, short circuit & reverse polarity protection. Power: 6-15Vdc 500mA

ES-2 Cebek Module £21.54
12Vdc Power Supply
 Single rail regulated power supply complete with transformer. 130mA max, low ripple, 12Vdc with adjustment.

FE-103 Cebek Module £13.16
MP3 Player Kit
 Plays MP3 files from an SD card, supports ID3 tag which can be displayed on optional LCD. Line & headphone output. Remote control add-on. Power: 12Vdc 100mA

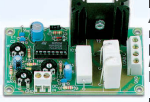
K8095 Velleman kit £39.99
DC to Pulse width Modulator
 A handy kit to accurately control DC motors etc. Overload & short circuit protection. Input voltage 2.5-35Vdc, Max output 6.5A. Power: 8-35Vdc

K8004 Velleman kit £9.95
Audio Analyser Kit
 A small spectrum analyser with LCD. Suitable for use on 2, 4 or 8Ω systems. 300mW to 1200W(2Ω) 20-20kHz Panel mounting, back-lit display. Power: 12Vdc 75mA

K8098 Velleman kit £31.65
USB DMX Interface
 512 DMX Channels controlled by PC via USB. Software & case included. Available as a kit or ready assembled module.

K8062 Velleman kit £47.90
VM116 Module £67.15
USB Interface Board
 Featuring 5 in, 8 digital outputs, 2 in & 2 analogue outputs. Supplied with software. Available as a kit or ready assembled module.

K8055 Velleman kit £24.80
VM110 Module £34.90
8 Channel USB Relay Board
 PC Controlled 16A relays with toggle, momentary or timed action. Test buttons included, available in a kit or assembled.

K8090 Velleman kit £39.95
VM8090 Module £58.40
Velleman PC Scope
 PC Based USB controlled 2 channel 60MHz oscilloscope with spectrum analyser & Transient recorder. 2 Scope probes & software included. See web site for full feature list.

PCSU1000 Velleman £249.00
Velleman PC Scope/Generator
 PC Based USB controlled 2 channel oscilloscope AND Function generator. Software included. See web site for full feature list.

PCSGU250 Velleman £113.67
RF Remote Control Transmitter
 Single channel RF keyfob transmitter with over 13,122 combinations. Certified radio frequency 433.92MHz. Power: 12Vdc 2mA (inc) For use with TL-1,2,3,4 receivers.

TL-5 Cebek Module £14.64
RF Remote Control Receiver
 Single channel RF receiver with relay output. Auto or manual code setup. Momentary output, 3A relay. Power: 12Vdc 60mA For use with TL-5 or TL-6 transmitters.

TL-1 Cebek Module £28.25
Keypad Access Control
 An electronic lock with up to ten 4 digit codes. Momentary or timed (1-60sec/1-60min) output. Relay 5A. Power: 12Vdc 100mA Keypad included.

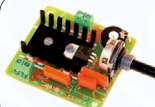
DA-03 Cebek Module £54.26
AC Motor Controller
 A 230Vac 375W motor speed control unit giving 33 to 98% of full power. Power: 230Vac

R-8 Cebek Module £12.14
1-180 Second Timer
 Universal timer with relay output. Time start upon power up or push button. LED indication. 5A Relay. Power: 12Vdc 60mA

I-1 Cebek Module £12.92
Cyclic Timer
 Universal timer with relay output. Time start upon power up or push button. On & Off times 0.3-60 Seconds, LED indication. 5A Relay. Power: 12Vdc 80mA

I-10 Cebek Module £14.12
Light Detector
 Adjustable light sensor operating a relay. Remote sensor & terminals for remote adjustment pot. 5A Relay. Power: 12Vdc 60mA

I-4 Cebek Module £13.98
Liquid Level Detector
 A liquid level operated relay. Remote sensor operates relay when in contact with a liquid. 5A Relay. Power: 12Vdc 60mA

I-6 Cebek Module £13.08
Thermostat
 A temperature controlled relay. Adjustable between -10 to 60°C Sensor on remote PCB. Connector for external adjustment pot. 5A Relay. Power: 12Vdc 60mA

I-8 Cebek Module £12.80
Start / Stop Relay
 Simple push button control of a relay. Either 1 or 2 button operation. 5A Relay. Power: 12Vdc 60mA

I-9 Cebek Module £12.83
Components Hardware Soldering Switches Test Equipment Transformers Motors
PCB Equipment Connectors Power Supplies Enclosures Relays

Editorial Offices:

EVERYDAY PRACTICAL ELECTRONICS
 EDITORIAL Wimborne Publishing Ltd., 113 Lynwood
 Drive, Merley, Wimborne, Dorset, BH21 1UU
Phone: (01202) 880299. **Fax:** (01202) 843233.
Email: enquiries@wimborne.co.uk
Website: www.epemag.com

See notes on **Readers' Technical Enquiries** below
 – we regret technical enquiries cannot be answered
 over the telephone.

Advertisement Offices:

Everyday Practical Electronics Advertisements
 113 Lynwood Drive, Merley, Wimborne, Dorset,
 BH21 1UU
Phone: 01202 880299 **Fax:** 01202 843233
Email: stewart.kearn@wimborne.co.uk

Editor: MATT PULZER
Consulting Editor: DAVID BARRINGTON
Subscriptions: MARILYN GOLDBERG
General Manager: FAY KEARN
Graphic Design: RYAN HAWKINS
Editorial/Admin: (01202) 880299
**Advertising and
 Business Manager:** STEWART KEARN
 (01202) 880299
On-line Editor: ALAN WINSTANLEY

Publisher: MIKE KENWARD

READERS' TECHNICAL ENQUIRIES

Email: techdept@wimborne.co.uk

We are unable to offer any advice on the use, purchase,
 repair or modification of commercial equipment or the
 incorporation or modification of designs published in
 the magazine. We regret that we cannot provide
 data or answer queries on articles or projects that are
 more than five years' old. Letters requiring a personal
 reply must be accompanied by a stamped self-
 addressed envelope or a self-addressed envelope and
 international reply coupons. We are not able to answer
 technical queries on the phone.

PROJECTS AND CIRCUITS

All reasonable precautions are taken to ensure that
 the advice and data given to readers is reliable. We
 cannot, however, guarantee it and we cannot accept
 legal responsibility for it.

A number of projects and circuits published in
 EPE employ voltages that can be lethal. You should
 not build, test, modify or renovate any item of mains-
 powered equipment unless you fully understand the
 safety aspects involved and you use an RCD adaptor.

COMPONENT SUPPLIES

We do not supply electronic components or kits for
 building the projects featured, these can be supplied
 by advertisers.

We advise readers to check that all parts are still
 available before commencing any project in a back-
 dated issue.

ADVERTISEMENTS

Although the proprietors and staff of EVERYDAY
 PRACTICAL ELECTRONICS take reasonable
 precautions to protect the interests of readers by
 ensuring as far as practicable that advertisements are
 bona fide, the magazine and its publishers cannot give
 any undertakings in respect of statements or claims
 made by advertisers, whether these advertisements
 are printed as part of the magazine, or in inserts.

The Publishers regret that under no circumstances
 will the magazine accept liability for non-receipt of
 goods ordered, or for late delivery, or for faults in
 manufacture.

**TRANSMITTERS/BUGS/TELEPHONE
 EQUIPMENT**

We advise readers that certain items of radio
 transmitting and telephone equipment which may
 be advertised in our pages cannot be legally used in
 the UK. Readers should check the law before buying
 any transmitting or telephone equipment, as a fine,
 confiscation of equipment and/or imprisonment can
 result from illegal use or ownership. The laws vary from
 country to country; readers should check local laws.

EPE EVERYDAY PRACTICAL ELECTRONICS

Powering circuits mechanically

I enjoy being an editor. It's a varied job, and since I am self-employed I get to work from home, which is a pleasant way to earn one's keep. However, generally speaking, it's a not the kind of work with a lot of 'perks'. I don't get bombarded with free oscilloscopes for review, or all-expenses-paid trips to Silicon Valley to watch Intel produce their latest microprocessor.

That said, I do get to go to various exhibitions around Britain, where I am offered all the cheap biros, Post-it note pads or 'amusingly' shaped memory sticks I can carry. Corporate promotional gifts may be free, but they are usually pretty unimaginative. However, the calculator shown below caught my eye recently. At first, I thought it was just another basic solar-powered freebie – not very interesting. I was about to move on when I saw the rep' demonstrating it to a potential customer. Instead of holding it under a convenient spotlight, he gave it a little shake and it sprang into life. Clever, so I picked one up and once I got it home I took the back off and found a simple and entirely comprehensible 'generator' – see the photographs on the right.

A high-turns solenoid is wrapped around a clear plastic tube, in which a cylindrical magnet (looks like the high-strength neodymium variety) can easily slide. The solenoid is connected to four diodes, so presumably a bridge rectifier – remember Faraday's and Lenz's laws? The EMF induced by the motion of the magnet will reverse as its direction of motion reverses, so we need a rectifier to produce a DC voltage. Last, but not least, there are two capacitors to smooth the output. Strictly speaking you only need one, and I am not sure why two are there unless a split rail is required, although why that should be in a digital calculator I am not sure. Perhaps the caps are just paralleled up to get the maximum amount of capacitance that can fit in the case.

I thought this was a rather elegant and pleasingly simple way to avoid batteries and solar cells. Perhaps some of our *Ingenuity Unlimited* fans can come up with some novel applications or better ways to generate the few millijoules needed to briefly run a circuit. If so, do let us know!

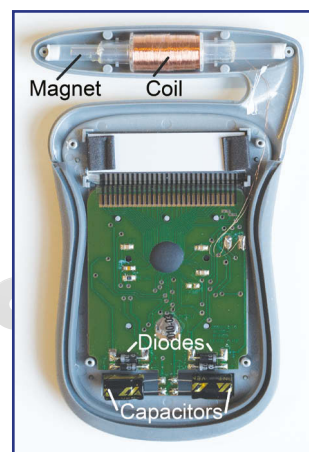

Martin

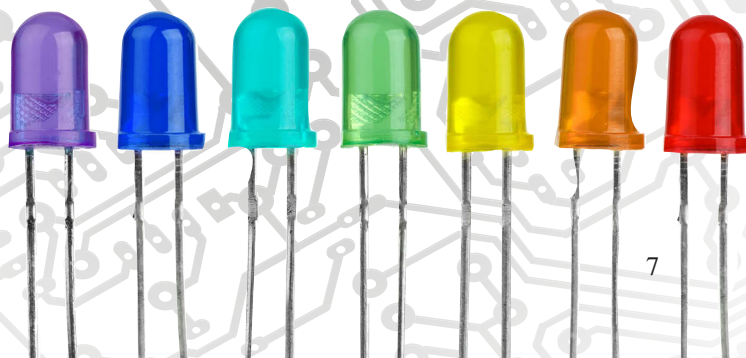

NEWS

A roundup of the latest Everyday News from the world of electronics



TV interference risk from 4G masts – by Barry Fox

January saw the UK's largest ever mobile spectrum auction get under way, with seven bidders (HKT, Everything Everywhere, Hutchison 3G UK, MLL Telecom, Niche Spectrum Ventures/BT, Telefónica UK/O2 and Vodafone) competing for 28 lots of spectrum in two separate bands – 800MHz and 2.6GHz. The spectrum will be used for new 4G/Long Term Evolution/WiMAX mobile broadband services. The total reserve

price for the spectrum was set at £1.36bn, but far higher returns (over £3bn) were expected.

TV interference

Regardless of who wins, and how much they pay the cash-strapped UK government, one thing is certain; the lower frequency 800MHz band, which was freed up when analogue terrestrial TV was switched off, will cause some (largely unpredictable and intermittent) interference to existing Freeview TV. The only doubt is over how much interference will be caused, to how many people and how sufferers will be helped.

The lack of interference from the 4G/LTE service offered since August 2012 by EE is irrelevant, because EE is reusing existing 2G frequencies at 1800MHz.

The 800MHz 4G band is very close to the 700MHz band frequencies used by Freeview. Co-channel interference is inevitable, especially for homes close to a 4G base station and where aerial amplifiers are used. Interference may well be variable and intermittent, making it even harder to tie cause to effect.

Help schemes

Communications Minister Ed Vaizey has pledged £180m for a 4G interference help scheme. The 4G operators will pay for

this and run the scheme through a company called Mobile Spectrum Ltd or DMSL Mitco. On Ofcom's advice, the government's DCMS assures that: 'the vast majority of affected households will simply need to fit their TV with a filter that will be supplied by the help scheme.'

However, this is for just one TV per household. Viewers with more than one set will have to buy extra filters.

Mitco will also have to run a public information campaign, maintain call centres and ensure that suitable filters are available and clearly labelled in retail outlets.

Alternatives to filters

The DCMS admits that in some cases the interference will be so bad that a filter will not fix the problem: 'A number of households may need to change platform, which could mean shifting from DTT to cable or satellite viewing, and this will be funded by the help scheme.'

Mitco will then be required to offer a change of platform, from Freeview to Freesat for example. In the few cases where there is no available alternative supplier, Mitco is required to look for bespoke solutions at a cost of up to £10,000 per household. They will also have to help older and disabled viewers, and supply vouchers to 'help with' the cost of employing an aerial contractor if an amplifier is mounted outside, for example on the aerial mast.

Ofcom assures that 'DCMS and Ofcom will be keeping a careful eye on how this all works'. DCMS is setting up an oversight board. Viewers can now only hope the 'help scheme' really helps, and the cell phone companies aren't given room to wriggle in the way they have become famous for wriggling when dealing with customer service and billing complaints.



4G may be the future for mobile broadband, but for houses located next to mobile base stations there may well be TV interference problems (Photo courtesy of www.e-shootershill.co.uk)

System boosts precision of GPS in cities by 90%

A system that researchers claim can improve the precision of GPS in cities by up to 90% has been described in the journal *Sensors* (December 2012). The technique is based on 'sensorial fusion', developed at Universidad Carlos III in Madrid.

The prototype incorporates a conventional GPS signal with those of other sensors (accelerometers and gyroscopes) to reduce the margin of error in establishing a location. 'We have managed to improve the determination of a vehicle's position in critical cases by between 50% and 90%, depending on the degree of the signals' degradation and the length of time that it is degraded', said researcher David Martín.

The error of a commercial car GPS is about 15m in an open field, where the receiver has wide visibility from the GPS satellites. However, in an urban setting, the determination of a vehicle's position can be off by more than 50m, due to the satellite signals bouncing off of obstacles like buildings or trees, or ricocheting around and along narrow streets. In certain cases, such as in tunnels, communication is completely lost.

A combination of sensors

The basic elements that make up this system are a GPS and a low cost 'inertial measurement unit' (IMU). The latter device integrates three accelerometers and three gyroscopes to measure changes in velocity and manoeuvres performed by the vehicle. Everything is then connected to a computer with software that merges the data and corrects the errors in the geographic coordinates.

However, this is just the start of how the car calculates its position. Optical and infrared cameras and laser detectors determine if painted road lines are crossed, or whether there are pedestrians in the vehicle's path.

The next step the Madrid researchers intend to take is to analyse the possibility of developing a system that makes use of the sensors that are built into smartphones, many of which are equipped with more than ten sensors, such as an accelerometer, a gyroscope, a magnetometer, GPS and cameras, in addition to Wi-Fi, Bluetooth or GSM communications. Using smartphones will help to drive down cost using technology most of us carry around every day.

SMARTPHONE IN SPACE



The Nexus-smartphone-based satellite will be operated from the Surrey Space Centre's ground station at the University of Surrey

STRaND-1, a UK satellite jointly developed by the University of Surrey's Surrey Space Centre (SSC) and Surrey Satellite Technology Limited (SSTL), is to be the world's first smartphone satellite in orbit.

The unique satellite, called STRaND-1 (the Surrey Training, Research and Nanosatellite Demonstrator), is a 4.3kg, 30cm CubeSat.

It will launch into a 785km sun-synchronous orbit on ISRO's Polar Satellite Launch Vehicle (PSLV) from Sriharikota, India.

It was developed by space engineers and researchers at Surrey, with the majority of the design and developmental work being carried out in their spare time. The build and test phase of the project has been completed in just three months.

At the heart of the satellite is a Google Nexus One smartphone with an Android operating system. Smartphones contain highly advanced technologies and incorporate several key features that are integral to a satellite – such as cameras, radio links, accelerometers and high performance computer processors – almost everything except the solar panels and propulsion.

Dr Chris Bridges, SSC's lead engineer on the project, commented: 'A smartphone on a satellite like this has never been launched before, but our tests have been pretty thorough, subjecting the phone to oven and freezer temperatures, to a vacuum and blasting it with radiation'.

For more information, visit: www.sstl.co.uk/Divisions/Earth-Observation-Science/Science-Missions/STRaND-nanosatellite

USB 3.0 PC scopes launched



Now available, a PC scope with USB 3.0

The first PC oscilloscopes with a USB 3.0 interface have been released by Pico Technology.

'USB 3.0 ports are appearing on most new computers and laptops,' explained managing director Alan Tong, 'so buyers of USB oscilloscopes will expect to benefit from the higher data transfer rate. With the new USB 3.0 PicoScopes, large data captures and streaming of large data sets are now much faster.'

The PicoScope 3207A is a two-channel USB oscilloscope with 250MHz bandwidth, 1GS/s sampling rate, 256MS (mega-sample) buffer memory and a built-in function generator. Basic timebase accuracy is ± 2 ppm. Other features included are: digital triggering for

accurate, stable waveform display, and equivalent-time sampling, which boosts the effective sampling rate to 10GS/s for repetitive signals.

The PicoScope 3207B has 512MS buffer memory and an additional 32k-sample arbitrary waveform generator, with a 100MS/s update rate. As the scope obtains its power from the USB port, there is no need for an external power adaptor.

The oscilloscopes are supplied with PicoScope software for Windows, which turns your computer into a powerful oscilloscope and spectrum analyser. The software includes many advanced features, such as automatic measurements, serial decoding of RS-232/UART, SPI, I²C, CAN, LIN and FlexRay data, and mask limit testing, that are only available as expensive add-ons for most competing scopes. Software updates are free of charge.

A free software development kit (SDK) is also available for those who wish to write their own data-acquisition programs. Example code in a number of languages is included.

The PicoScope 3207A and 3207B cost £1099 and £1199. For more details, visit: www.picotech.com

EP3 EVERYDAY PRACTICAL ELECTRONICS

If you have some breaking news you would like to share with our readers, then please email:

editorial@wimborne.co.uk

By NICHOLAS VINEN

SoftStarter – tame t

Are you alarmed by the juicy ‘splat’ from your mains power point when you plug in something like a large plasma TV? Do you sometimes burn out light and power point switches because of the surge currents at switch-on? Or perhaps you occasionally trip circuit breakers because of appliance switch-on surge currents. This is a very common problem, but there is a simple cure: our *SoftStarter*. It tames those nasty surge currents while having no effect on appliance performance.

THIS PROJECT was triggered by a number of readers experiencing problems with switch-on surge currents.

The first was a school teacher who wanted to switch on banks of laptop computers in a language laboratory. Each time he attempted to do so, the mains circuit breakers tripped out. The breakers did this even though the total power drain of the laptops was far less than the breaker’s rated current.

Eventually, he found that the only way to switch on without tripping the breakers was to switch on the laptops in groups of three or four.

The second instance was a reader who fitted a large number of 10W compact fluorescent lamps to a large chandelier – he was trying to toe the government line by not using those nasty (but attractive candle style) incandescent lamps. He found that each time he switched on the chandelier, it tripped the 10A breaker.

We have a similar problem in our offices with computer workstations comprising two monitors and a desktop PC. Each combination has around 1.15 μ F of capacitance at the mains plug and can draw well in excess of 100A when switched on!

Worse, one of our staff members measured the input capacitance of his current model Panasonic 50-inch plasma TV at 1.3 μ F, between live and neutral (with its mains

switch off). Add in the capacitance of a DVD player and VCR used to feed the Plasma set and you can start to see there is a major problem.

Switch-mode

All of the above problems relate to appliances which have switch-mode power supplies. In essence, these look and behave like a large capacitor being switched across the 230V AC mains supply. No wonder you get a big ‘splat’ from the power switch.

The essentials of a switch-mode power supply are shown in Fig.1. There is typically a 470nF capacitor connected directly between the live (L) and neutral (N) leads, followed by a bridge rectifier feeding a 470 μ F 400V electrolytic capacitor to develop around 325V before the switch-mode circuitry itself. No wonder these circuits generate such big surge currents.

We did a simulation of this circuit to get a handle on how big these currents can be. Fig.2 tells the story. Depending on the moment of actual switch-on, the peak current can easily be more than 200A, and this is backed up by some scope measurements which tell the same story.

Note that some switch-mode power supplies have active power factor correction (active PFC) which involves extra circuitry. This reduces the in-rush current, but there is still an initial surge as the storage capacitor(s) charge.

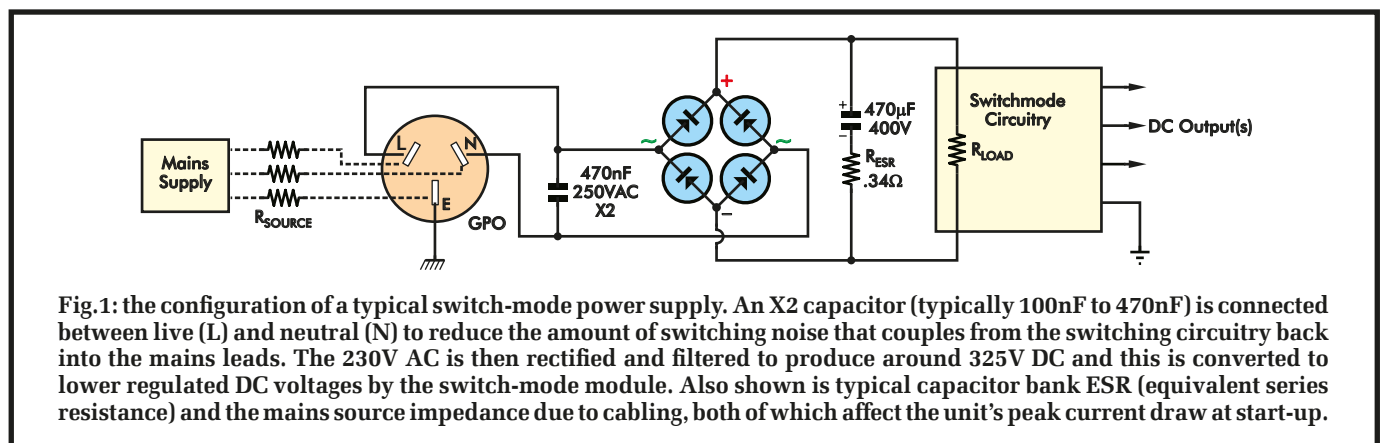

Fig.1: the configuration of a typical switch-mode power supply. An X2 capacitor (typically 100nF to 470nF) is connected between live (L) and neutral (N) to reduce the amount of switching noise that couples from the switching circuitry back into the mains leads. The 230V AC is then rectified and filtered to produce around 325V DC and this is converted to lower regulated DC voltages by the switch-mode module. Also shown is typical capacitor bank ESR (equivalent series resistance) and the mains source impedance due to cabling, both of which affect the unit’s peak current draw at start-up.

The surge current menace!

Here's the SoftStarter in the form we believe will be the most popular – in line with a 4-way power-board, which means four different devices (computer, monitor, modem and CFL desk lamp for example) all can have their switch-mode supplies 'tamed'.

While no switch-mode circuitry is involved, a similar surge current problem can occur when large transformers are followed by bridge rectifiers and large capacitors.

Think about the reader who built a very large power amplifier with a 1kVA toroid power transformer. Switching it on could also trip a circuit breaker or cause the room lights to momentarily flicker.

SoftStarter solution

We actually tried several different approaches before coming up with the *SoftStarter*. Perhaps the simplest and most obvious approach is just to wire a high current NTC (negative temperature coefficient) thermistor in series with the 230V AC mains supply, eg, inside a power board.

These devices initially have a fairly high resistance, which drops quickly as they heat up. The high initial resistance limits the in-rush current, and after a short period, this drops enough to allow normal current to flow into the load after the initial surge.

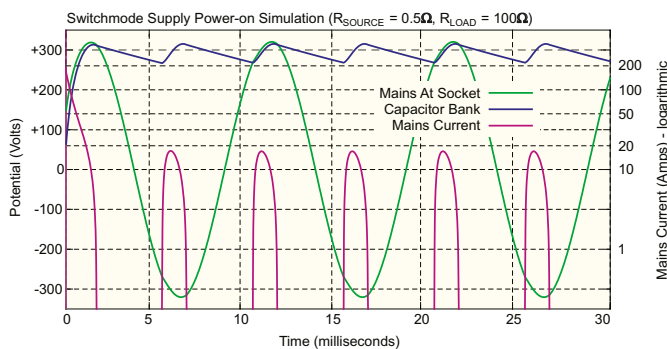

Fig.2: SPICE simulation of Fig.1. Mains source impedances are set to 0.5Ω and the load resistance is 100Ω . In-rush current peaks at over 200A, limited by the mains source impedance, bridge rectifier impedance and capacitor bank ESR. The capacitor bank charges almost completely in the first half-cycle. The high current distorts the mains waveform both during the initial in-rush and at the voltage peaks, where some 'flat-topping' is visible.

WARNING!

This SoftStart circuit is powered directly from the 230V AC mains and operates at lethal voltages. **DO NOT TOUCH ANY PART OF THE CIRCUIT WHILE IT IS PLUGGED INTO A MAINS OUTLET OR CONNECTED TO MAINS WIRING** and do not operate the circuit outside its plastic case or without the lid screwed onto the case.

The problem is that they run really hot – up to 228°C or higher. This is unavoidable, since they rely on the heat to lower their resistance and allow enough current to flow.

Plainly, they run too hot to be installed inside a plastic power board; they would melt the plastic. Apart from that, it's a waste of power. Depending on the load current, dissipation could be in excess of 5W.

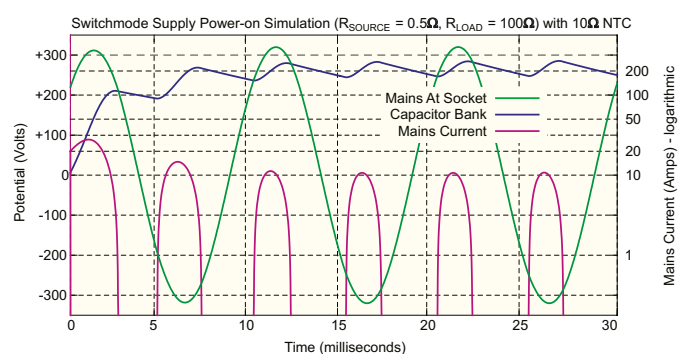

Fig.3: SPICE simulation with the same circuit as shown in Fig.1, but with a 10Ω 15A NTC thermistor connected in series between the mains socket and suppression capacitor/bridge rectifier. The capacitor bank charges more slowly, over several cycles and peak current is reduced to around 30A (close to our measurements). Note how the bridge conducts for a longer period, even after the capacitor bank has charged.

Constructional Project

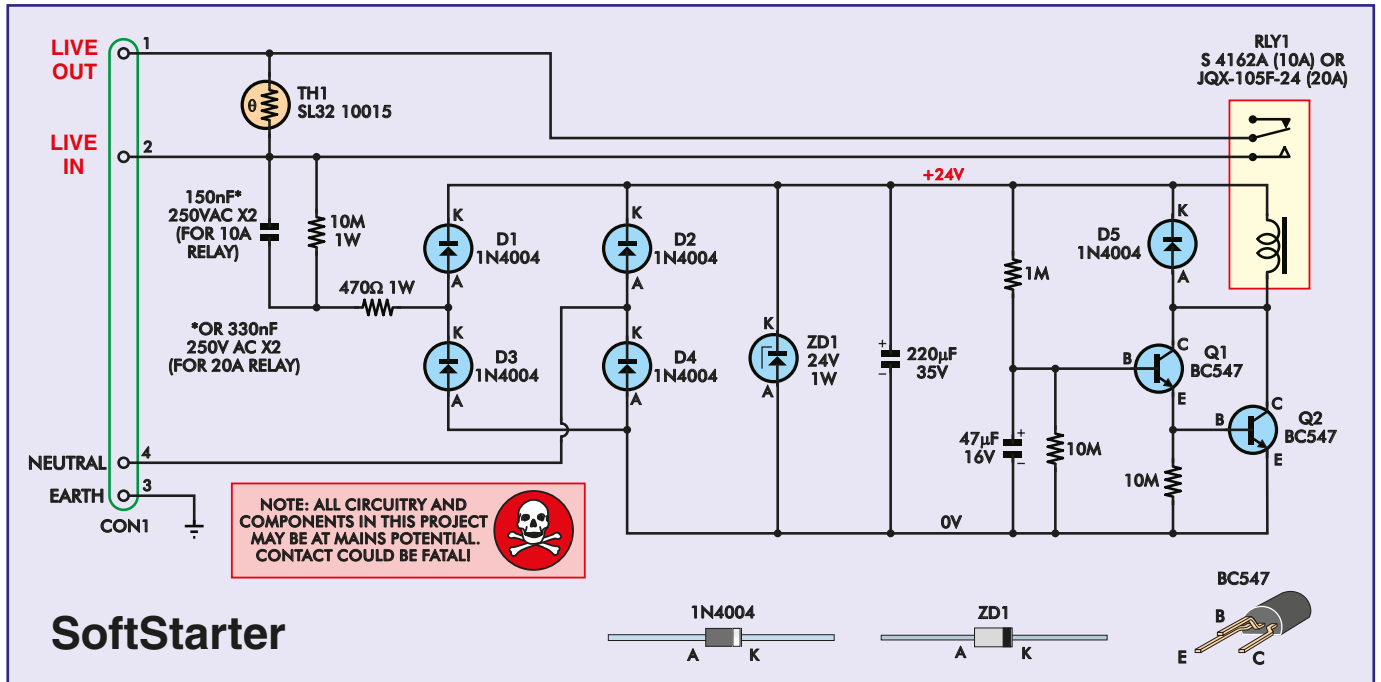

Fig.4: the complete circuit diagram of the *SoftStarter*. NTC thermistor TH1 limits in-rush current and after about two seconds, it is shorted out by relay RLY1 for minimal heat generation and power loss. NPN transistors Q1 and Q2 drive the relay coil and their switch-on is delayed by the 47µF capacitor. The +24V rail is derived from the mains using an X2 series capacitor, bridge rectifier and Zener diode.

Our solution is simple – we use a relay to short out the thermistor after a few seconds. The voltage drop across the relay is very low and so there’s virtually no power loss apart from that required to keep the relay energised. In the case of our *SoftStarter*, this is less than half a watt.

The proof that it works is in Fig.6. This shows the same computer set-up as in Fig.5 being switched on with the *SoftStarter* connected in series. The surge current is now limited to around 25A.

Note that the current waveform is much smoother and lacks the big initial spike. Note also that the power supply capacitors charge over many more mains cycles than they would without the *SoftStarter* connected.

A number of scope screen grabs in this article reinforce the story: without the *SoftStarter* you get big in-rush currents and splats from the power switch. Those splats, by the way, are not just annoying: each one is responsible for just a little more of the switch contacts melting and wearing away. However, with the *SoftStarter*, everything is sweetness and light and there is no drama at switch-on.

Two versions

The *SoftStarter* can be built in two different ways. First, its PCB can be housed inside a UB3-size box in-line with a standard power board, extension lead or equipment mains lead. It also fits into a standard electrical junction

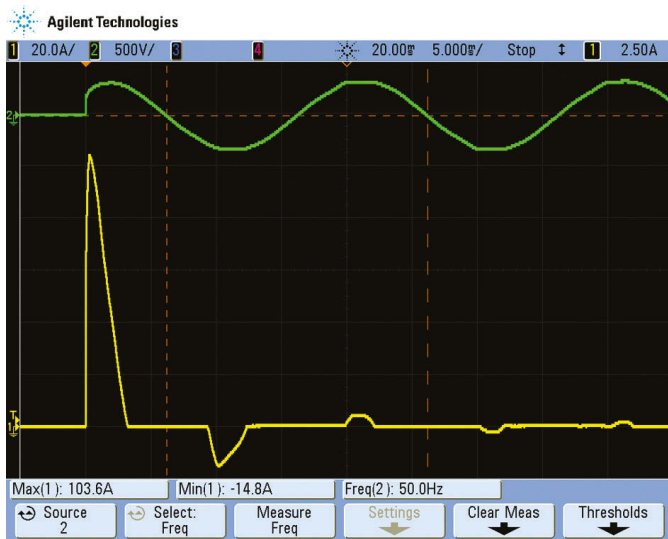

Fig.5: current for a computer workstation over the first few mains cycles after power is applied. The initial draw of 103.6A is due to the initial charging of the capacitor banks in switch-mode supplies. The second half-cycle peak is much lower.

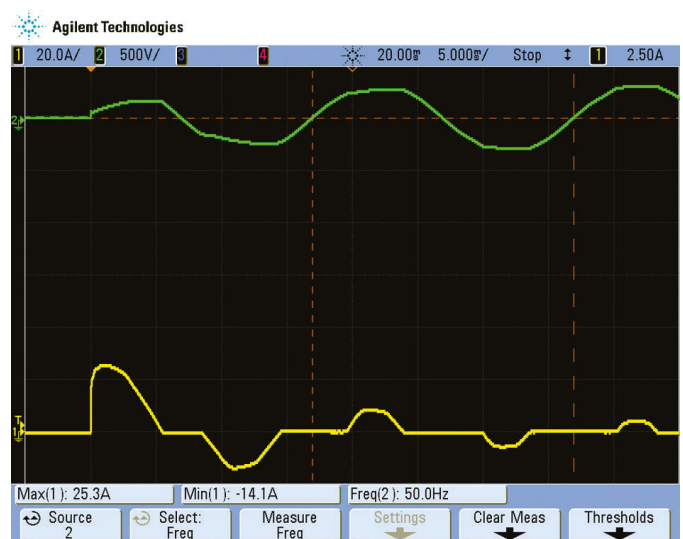
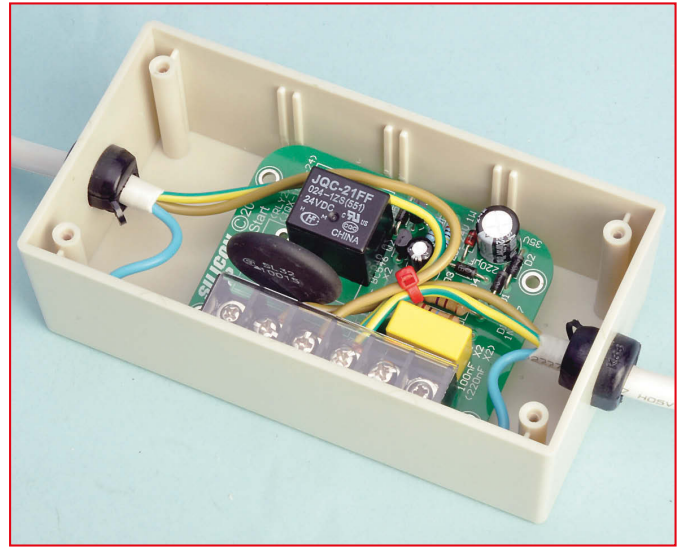
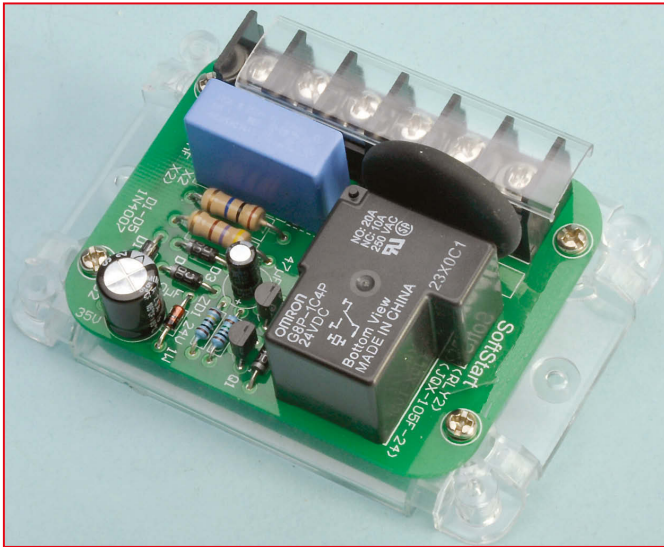

Fig.6: the same situation as Fig.5, but with the *SoftStarter* in use. Maximum current draw is much lower at 25.3A for the first half-cycle and 14.1A for the second. The capacitor banks charge more gradually, over five full mains cycles or so (100ms).



Here are the two versions of the *SoftStarter* – on the left, the PCB is attached to the base of a standard electrical junction box. This version has the 20A relay, but again, it could be the 10A relay. On the right is the same board (with 10A relay) placed inside a standard UB3-size plastic box, as shown in the photo at the start of this article.

box so that it can be permanently wired into, say, a lighting circuit. It can handle loads of up to 10A or 2300W.

Circuit description

Refer now to the complete circuit diagram, shown in Fig.4. Incoming mains power is wired to the LIVE IN and NEUTRAL terminals, while the load is connected to the LIVE OUT and NEUTRAL terminals.

NTC thermistor TH1 is permanently connected between the incoming live line and the load. This is an SL32 10015 thermistor, with a nominal resistance at 25°C of 10Ω, falling to 0.048Ω at 228°C, which is its sustained body operating temperature with a load current of 15A. That is its rated maximum steady-state current, and it takes around four minutes to reach operating temperature under full load conditions.

In our application, this will never happen as it's shorted out after about two seconds by the contacts of relay RLY1.

NTC thermistors have a few advantages over power resistors in this role. First, they are rated to handle the very high (~250W) initial dissipation. Second, their natural drop in resistance as they heat up provides a gradual increase in current. Finally, they are much more compact than a typical power resistor of equivalent current rating.

There are no timer ICs or oscillators in this circuit. Instead, the relay time delay of two seconds is provided by the low-pass filter formed by the 1MΩ resistor and 47μF capacitor, in combination with the base-emitter voltages of NPN transistors Q1 and Q2.

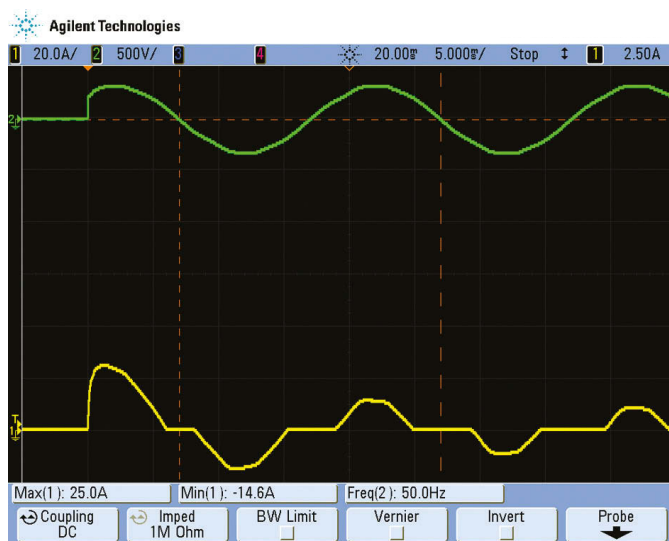

Fig.7: current flow for a 300VA toroidal transformer charging a large capacitor bank through a bridge rectifier, at switch-on. Peak current draw is 24A on the first cycle and 14A on the second. It could be much higher with a larger transformer.

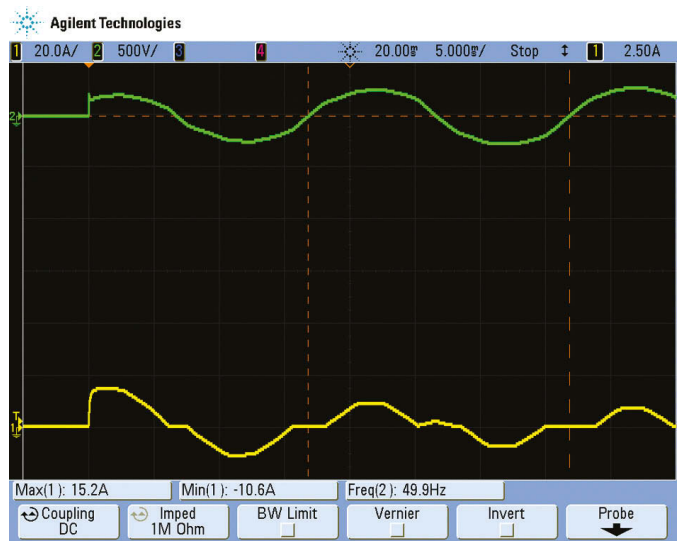

Fig.8: the toroidal transformer-based power supply, this time with the *SoftStarter* connected up. The inrush is much lower with a peak of 14A on the first cycle and 11A on the second. Current is drawn over a larger portion of the mains cycle.

Constructional Project

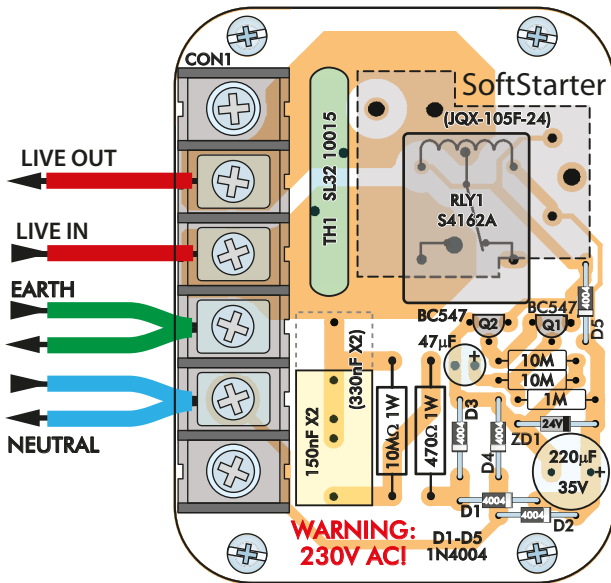

Fig.9: the component overlay for the *SoftStarter* with a straight-on shot of the PCB at right for comparison. Take care with the mains wiring and NEVER operate the *SoftStarter* with the lid off the case – it bites!

At switch-on, the 220µF capacitor is initially charged to 24V and the 47µF capacitor starts out discharged. After a couple of seconds, when the charge across the 47µF capacitor reaches about 1.5V, the Darlington formed by NPN transistors Q1 and Q2 turns on and energises the relay. Its contacts short out the NTC thermistor, applying the full 230V AC to whatever load is being switched on.

After that, the full load current passes through the relay until such time as incoming mains power is switched off. After a second or so, the 220µF capacitor discharges and the relay switches off. Diode D5 protects Q1 and Q2 from the resulting inductive voltage spike.

After switch-off, the 47µF capacitor discharges via its parallel 10MΩ resistor (also via Q1's base-emitter junction and the 1MΩ resistor). After about 30 seconds it's sufficiently discharged for the unit to be switched back on again with close to the normal two-second delay.

If it's switched back on earlier, the delay will be shorter, but should still be sufficient.

Power supply

The 24V rail is derived from the 230V AC mains using a capacitor/Zener regulated supply. Diodes D1 to D4 form a bridge rectifier feeding the 220µF filter capacitor and 24V Zener diode ZD1, which limits the voltage across this capacitor to around 24V.

If we simply connected the full 230V AC mains to the input of the rectifier, it and the Zener diode would burn out in spectacular fashion due to the virtually unlimited current flow.

This is similar to the problem we are trying to avoid with the *SoftStarter*! We need to limit this current to a safe level.

The obvious way to do this is to use a resistor, but then that resistor would have about 200V across it and its dissipation would be high, making the circuit very inefficient. So, instead of using resistance, we use the reactance of a capacitor to limit the current. We simply choose one with an impedance of around 20kΩ at 50Hz.

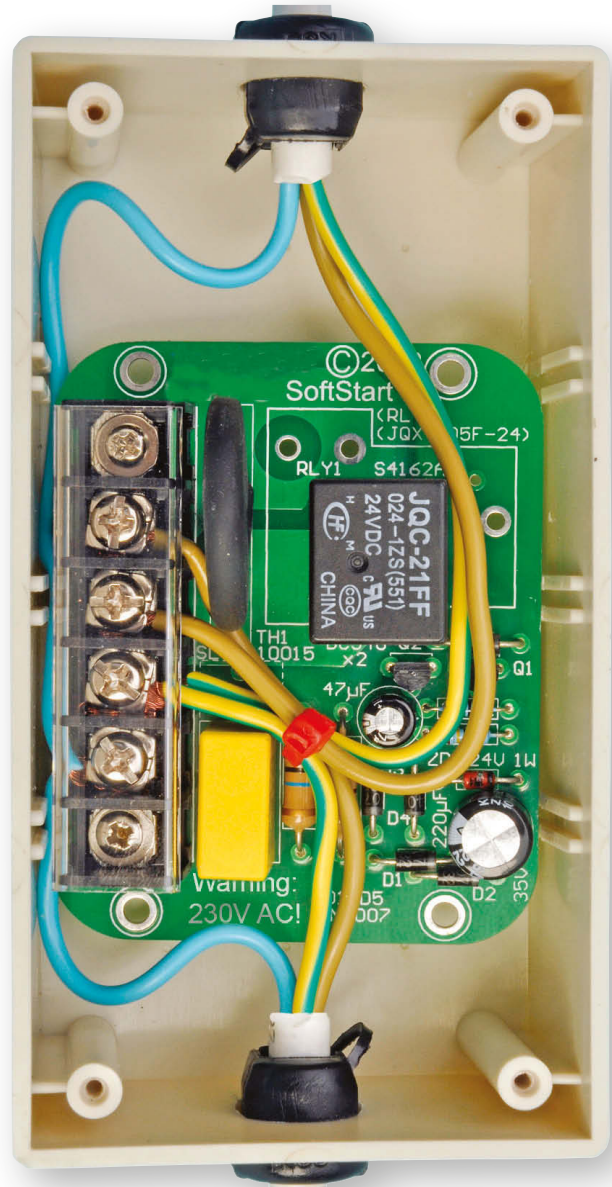

The formula for capacitor reactance is given by:

$$\frac{1}{(2 \pi f C)}$$

So, for a 150nF capacitor at 50Hz we get 21.2kΩ. This gives a much higher efficiency; over 50%.

This process is illustrated in Fig.10, the output of a SPICE simulation of the power supply circuit (using a 220nF capacitor, but the principle is the same).

The dashed green trace shows the voltage across the X2 capacitor and the difference between it and the mains voltage waveform (red trace) is the voltage across the rectifier, which is limited to around ±25V due to the Zener diode.

The dashed mauve trace shows the current flowing through this X2 capacitor, while the dotted blue trace shows the product of this current with the mains voltage, ie, the instantaneous power.

This power figure is positive when the current and voltage are in phase, and this represents power drawn from the mains, while when it is negative, the current and voltage are out of phase and it represents current flowing back into mains.

Parts List – SoftStarter

- 1 PCB, code 895, available from the *EPE PCB Service*, size 58mm × 76mm
- 1 6-position, 4-way PCB-mount terminal barrier (CON1)
- 2 M3 × 15mm machine screws with flat washers, star washers and nuts
- 1 Ametherm SL32 10015 NTC thermistor (Element14 1653459)
- 1 10A coil SPDT relay, 24V DC (Altronics S4162A or equivalent) or
- 1 20A SPDT relay, 24V DC coil (Futurlec JQX-105F-24 or equivalent)
- 1 UB3-size plastic box or mains junction box

Semiconductors

- 2 BC547 100mA NPN transistors (Q1, Q2)
- 1 24V 1W Zener diode (ZD1)
- 5 1N4004 1A diodes (D1 to D5)

Capacitors

- 1 220μF 35V/50V radial electrolytic
 - 1 47μF 16V radial electrolytic
 - 1 150nF X2* (for 10A relay) or
 - 1 330nF X2* (for 20A relay)
- (* X2 capacitors will have their value printed on them)

Resistors (0.25W, 5%)

- 1 10MΩ 1W (code: brown black blue gold)
- 2 10MΩ (code: brown black blue gold)
- 1 1MΩ (code: brown black green gold)
- 1 470Ω 1W (code: yellow violet brown gold)

Additional parts for UB3-size box version

- 2 cord-grip grommets to suit 7.4-8.2mm cable
- 1 short length 2.5mm diameter heatshrink tubing
- 1 power board
- 1 small cable tie

Additional parts for junction box version

- 4 No.4 × 9mm self-tapping screws

As you can see, power tends to be drawn from the mains when the X2 capacitor is charging, ie, when the voltage across it is increasing in absolute terms. It is returned to the mains when this capacitor is discharging. There is also the additional current flow which is that consumed by the circuit being driven, which is on top of the capacitor charge/discharge currents.

The actual power consumed is the difference between that flowing into and out of the circuit. As you can see from the figure, the area under the curve representing the power drawn from mains is slightly larger than that returned, and the simulation gives the difference, in this case, a 421mW. This is the real power drawn by the circuit.

The apparent power is calculated by multiplying the RMS current by the RMS voltage (ie, 230V). The RMS current is 15.6mA; therefore, the apparent power is 3.59VA. This gives a power factor of $0.421 / 3.59 = 0.12$. This may seem low, but given how little actual power the circuit draws, it isn't a problem.

If we re-run the calculations using a 150nF capacitor, we get a real power of 210mW, an RMS current of 10.7mA, an

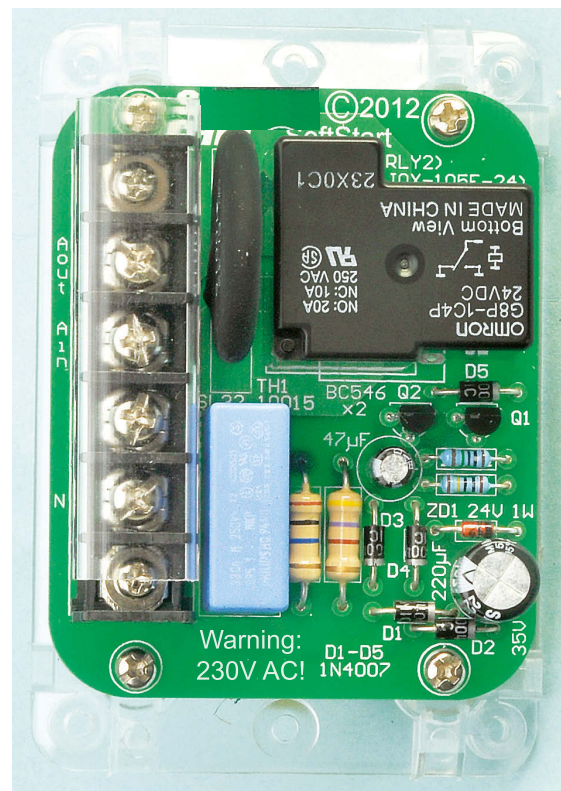

A straight-on pic of the alternative mounting, the mains junction box. This is actually on the baseplate; the box fits over the top when the baseplate is mounted (eg, to a joist).

apparent power of 2.46W and a power factor of 0.085. This agrees almost exactly with our measurements.

The 10MΩ resistor has negligible effect on the operation of the circuit and simply serves to discharge the X2 capacitor once the unit is unplugged (so you won't get a shock if you open up the box). The 470Ω resistor limits the in-rush current when the X2 capacitor is initially charged to a maximum of 0.5A. Both of these resistors are 1W types, since these are generally rated for use with mains voltages.

An important aspect to note is that while 24V Zener diode ZD1 limits the voltage across the filter capacitor (220μF) to 24V initially, once the relay is actually energised, the voltage will drop to around 15V to 16V and ZD1 no longer conducts.

The reason for this is that the voltage divider formed by the reactance of the X2 capacitor, the 470Ω series resistor and the relay coil resistance (around 1600Ω) limits the filter capacitor voltage to around 15.8V. This is enough to keep the relay reliably energised, but reduces the power consumption of the circuit.

Relay and X2 capacitors

One of two specified relays can be used: one is rated to switch 10A, the other is physically larger and is rated at 20A (7200VA).

We have specified a 150nF X2 capacitor for use with the 10A-rated relay and a 330nF X2 capacitor for the 20A-rated relay because its coil resistance is lower, at 660Ω.

Construction

The *SoftStarter* is built on a 58mm × 76mm PCB, coded 895. It is double-sided with plated through-holes, so the

Why is the 50Hz AC mains waveform distorted?

Everyone knows that the 50Hz AC mains waveform is a sinewave, right?

Well, in theory it is a sinewave; but in practice it is distorted because the peaks have been clipped off. For years now, our scope screen grabs have shown this, but we have not dwelled on the reasons why.

Recently though, we have had emails from readers who have sent photos of their scope screens showing the classic flat-topping of the mains waveform. And they want to know why this is happening.

You can blame this gross distortion of the mains waveform on two factors: gas discharge lighting and switch-mode power supplies.

Gas discharge lighting refers to all lighting systems which use an electric current through a gas to generate light. It applies to all high and low-pressure sodium lamps, mercury vapour lamps and fluorescent lights.

In each of these cases, the gas discharge draws current from the AC mains supply only when the actual voltage across the lamp exceeds about 100V. So the current is only drawn from the peaks of the waveform and this inevitably loads down or clips off the peaks.

In recent years, the situation has become much worse for the electricity generators and distributors, with the widespread use of switch-mode power supplies in virtually all electronic appliances.

It more or less started with the advent of PCs and their adoption of the more efficient switch-mode rather than conventional mains transformer-driven power supplies, which are much heavier, bulkier and more expensive.

Switch-mode power supplies were naturally also used in laptop supplies, then TV sets, DVD players and so on. Now they are used in virtually all electronic equipment with the sole exception of high performance audio amplifiers.

Naturally, all those large power-hungry Plasma TVs (albeit these days not quite so power-hungry) and large-screen LCD TV sets use switch-mode supplies.

The reason why switch-mode power supplies are such a problem is that they all essentially consist of a bridge rectifier and a big capacitor, followed by the switch-mode circuitry itself. It is the bridge rectifier and big capacitor which is the problem because current only flows into the capacitor at the peaks of the 50Hz mains sinewave.

All of the power drawn by the appliance is drawn from the mains during the peaks of the waveform – not at the other times (unless they are fitted with active power factor correction and relatively few are).

Have a look at the simulation of Fig.2 on the second page of the *SoftStarter* article. This set of curves depicts what happens: large pulse currents, which coincide with the peaks of the mains waveform.

The simulation is for a 100Ω load which will draw a nominal 529W from 230V AC mains. But the current drawn from the mains is not a nice sinusoidal 2.3A, but a pulse waveform with peaks of about 15A!

No wonder the peaks of the waveform are being clipped off so severely.

To make the problem even worse, large appliances such as washing machines and inverter-driven air-conditioners also have large capacitor-input power supplies, ie, the same as the front-end of switch-mode power supplies.

It's not just domestic power loads which are causing the mains distortion. It is just as bad in industry, which is a big user of gas discharge lighting.

Consider those large AC drives used in industry, which consist of three-phase induction motors with variable-frequency, variable-voltage drives (think of them as big inverters). Also widespread in industry are single-phase and three-phase inverter-driven welders. Yep, they all use large capacitor-input power supplies.

And remember those high-performance audio amplifiers which don't have switch-mode power supplies? They still use a capacitor-input power supply following the large and heavy mains transformer – so they are just as bad as switch-mode power supplies in drawing large peak currents from the peaks of the mains waveform.

Finally, let us not forget compact fluorescent lamps (CFLs). Every one of those has a switch-mode power supply to drive the fluorescent tube.

Also, 12V halogen down-lights are another offender; these days they are driven by so-called 'electronic' transformers, which – you guessed it – are another form of switch-mode power supply.

And, of course, there are the even tinier switch-mode plugpacks we use to charge our mobile phones, iPods, iPads and MP3 players.

What a nightmare! – in comparison with all of these, the much-maligned incandescent lamp is a relatively benign resistive load!

Distortion analysis

To demonstrate the degree of the problem, have a look at the scope screen grab above right. This shows a typical 50Hz mains waveform (green trace) as measured in our offices.

Not only can you see the characteristic flat-topping, but also the slopes of the sinewave show some ripples, a further artefact of the nasty loads imposed by all gas discharge lights and capacitor-input power supplies.

Just to make it more interesting, we decided to do an FFT analysis of the distorted waveform. This shows harmonics of the 50Hz waveform out to the 19th, ie, to 950Hz. These are depicted as the purple spikes. The FFT (Fast Fourier Transform – essentially a frequency spectrum) shows that the harmonics are predominantly odd, eg, 3rd, 5th, 7th, 9th, 11th and so on, corresponding to 150Hz, 250Hz, 350Hz, 450Hz, 550Hz...

We also calculated harmonic distortion of the waveform based on the FFT and the result was 2%. If that was an audio amplifier, we would reject it. Unfortunately, the electricity distributors and consumers cannot.

As an aside, notice that the on-screen measurements show that the mains waveform has an RMS value of

By LEO SIMPSON

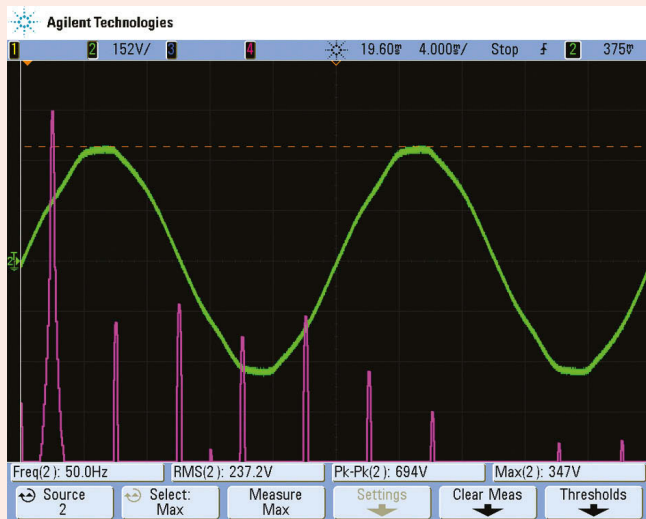

This screen grab shows the typical flat-topping of the 50Hz AC mains waveform (green trace) caused by the peak currents drawn by gas discharge lighting and switch-mode power supplies. The purple spikes show the relative amplitudes of the 50Hz fundamental and the odd harmonics up to 550Hz. In fact, the harmonics are significant up to at least the 19th, 950Hz.

237.2V and a peak-to-peak value of 694V (or 347V peak).

If that flat-topping was not present and the mains waveform was a pure sinewave, the peak-to-peak value would only be 670.8V (335V peak). So in effect, the electricity generators are having to deliver a larger peak-to-peak waveform in order that the customer gets an RMS voltage within the normal range.

And if that flat-topping, with its higher peak power on the waveform crests did not occur, the power losses in the entire electricity grid would be less, by at least a few percent.

Think about that next time you switch on any piece of electronic equipment or flick a switch to light a room with fluorescents, CFL or otherwise.

We should conclude with a note about 'dirty power'. This is a buzz word used by purveyors of power factor correction doodads which supposedly 'clean up' the mains waveform. They don't work.

Reproduced by arrangement
with SILICON CHIP
magazine 2013.
www.siliconchip.com.au

Just one of the so-called 'power saver' boxes we've looked at over the years. They are supposed to work by cleaning up your 'dirty' power waveform. Only one minor problem with these devices: they don't work!

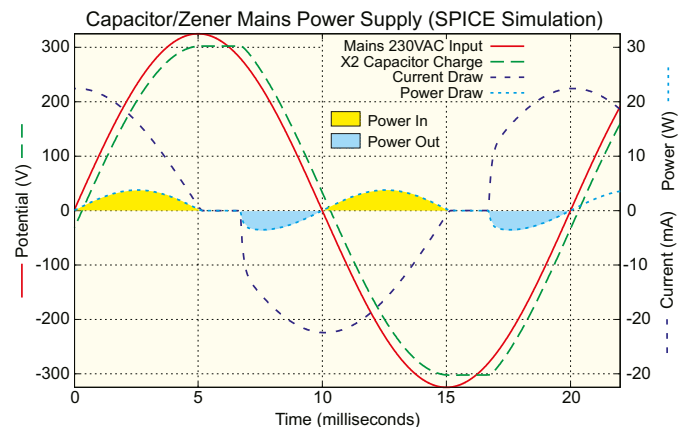

Fig.10: SPICE simulation output showing how the X2 capacitor/Zener power supply works. The X2 capacitor charges and discharges with each mains half-cycle, dropping the 325V DC peak voltage from mains to 24V. The extra energy from the higher voltage is stored in the capacitor and returned to the grid later in the half-cycle.

top layer can carry some of the load current. This board is available from the *EPE PCB Service*.

Start board assembly by fitting the three smaller resistors. Use a DMM (digital multimeter) to check their values. Follow with the five standard diodes and the Zener diode, oriented as shown on the overlay diagram (Fig.9). All diodes have their cathode stripes facing either the right side or bottom of the PCB. You can then fit the two 1W resistors, again use a DMM to check their values.

Crank the leads of the two BC547 transistors to suit the PCB mounting holes, using small pliers, then solder them in place. Follow with the small and then larger electrolytic capacitors. In both cases, the longer positive lead goes in towards the right side of the board.

The X2 capacitor and relay go in next. Use 150nF for the 10A relay or a 330nF for the 20A relay. You may need to turn up your soldering iron temperature to solder the relay because it connects to a large copper area. Then fit the thermistor, making sure it is pushed down as far as it will go before soldering its leads. It will also need a hot iron.

Attach the terminal barrier using two M3 x 15mm machine screws. Place flat washers under the heads and star washers between the nuts and PCB, then tighten them down. Check the terminal barrier is parallel to the edge of the PCB and then solder its pins again with a hot iron.

Housing

As already noted, the *SoftStarter* PCB can be installed in either a UB3-size box (in-line with a standard four-way 230V AC power board or extension cord) or in a standard junction box, if the device is to be permanently wired into a circuit. We will deal with installation in the plastic box first.

Originally, we designed the PCB to snap into the moulded side rails of the UB3 box, but the thermistor is quite tall and interfered with the lid, so we have made the final board narrower and it simply sits in the bottom of the case. It can be glued in place after it has been wired up and tested, so it can't move and put stress on the wiring.

Start by drilling a hole, centred in each end of the box, 4mm to 5mm at first, then enlarge them to 14mm using a tapered reamer or stepped drill bit. It's better to make the holes slightly too small and enlarge them

Constructional Project

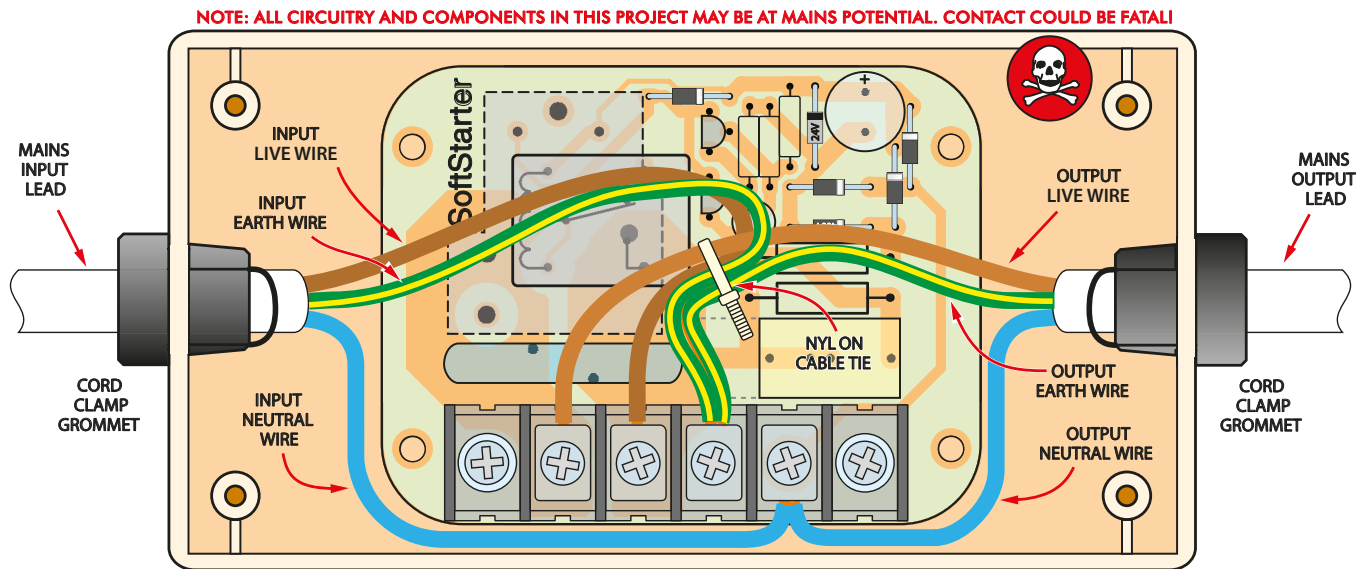

Fig.11: here's how to wire the *SoftStarter* inside the UB3-size plastic box. We placed it in line with a standard four-way powerboard – they're the cheapest way to get a mains plug, cord and (four) sockets.

later if necessary, since if they are too big, the cord-grip grommets will be loose and you will have to get a new box and start again.

The holes can then be elongated with a file in one direction, making a 14mm × 15.9mm opening (flat sides, rounded ends), to prevent the grommets from rotating.

Now cut the power board cord. We cut ours about 23cm from the power board so that the *SoftStarter* unit sits close to the board. Strip 75mm of the outer insulation, then expose 7mm of copper from the live, neutral and earth wires. At the other (plug) end, strip 130mm of the outer insulation, then the inner wires the same as before.

Place one of the cables inside a cord-grip grommet, with the narrower part towards the exposed wires and a small amount of the outer insulation protruding beyond the grommet. If you're lucky enough to have a grommet insertion tool you can use that, but otherwise, squeeze it together hard with a large pair of pliers and then push it into one of the holes in the box. This requires quite a bit of brute force and co-ordination, but if you do it right, the grommet will go in and it won't be possible to pull it out.

If it won't fit, enlarge the hole very slightly and try again. **Give the cords a firm tug to check they are anchored properly – you must not be able to pull them out or move them.**

Now twist the exposed strands of the live and neutral wires and screw them into the appropriate locations on the terminal barrier. Refer to the wiring diagram of Fig.11. The two neutral wires go into the location marked 'N' and should be twisted together.

The live wire from the power board goes to the terminal at the opposite end ('LIVE OUT') while the live wire from the plug goes next to that ('LIVE IN'). Twist the two earth wires together tightly and attach them to the terminal marked E. **In each case, ensure that the screw is done up tightly and that there are no exposed or stray copper strands.**

You can then place cable ties to hold the live and earth wiring in place (see photo). Secure the PCB into the bottom of the box using hot melt glue or silicone sealant and fit the lid.

Junction box

We also designed the board to fit in a junction box. The PCB's four mounting holes should line up with those in the base of the junction box, and the rounded corners leave enough room to access the other mounting holes, so you can screw it to a ceiling joist or whatever.

The 230V AC mains wires can enter the box lid from the side, using one or two of the knock-out sections. *Note that if it is to be installed in permanent wiring, the task should be done by a professional electrician or suitably qualified person.*

Check the wiring

Going back to the version in a UB3 box, before powering up, it's a good idea to do some basic tests. Measure the resistance between the incoming and outgoing live wires – it should be close to 10Ω, which is the cold resistance of the NTC thermistor. If it is much lower than this, you may have a short circuit somewhere.

Also check the resistance between each live line and the neutral line. The reading should be around 15MΩ. Again, if it is low, check carefully for shorts.

Finally, check for continuity (ie, 0Ω) between the earths of the in-going and out-going power cord. Then apply power (it isn't necessary to attach a load). After about two seconds you should hear the click as the relay turns on. Remove power and the relay will click again within a second or so, as it releases.

Assuming all is well, repeat the test with a load and this should confirm that it is working properly. For best results, once you have switched off power to the *SoftStarter*, wait at least 30 seconds before turning it back on.

EPE

EPE
EXCLUSIVE

Win one of two Microchip mTouch AR1000 Development Kits

EVERYDAY PRACTICAL ELECTRONICS is offering its readers the chance to win a **Microchip mTouch AR1000 Development Kit**. The kit provides everything designers need to get started using AR1000 resistive controllers and includes the AR1000 development board, a 7-inch four-wire resistive touch screen, a PICkit Serial Analyzer and all necessary interface cables. It also comes with a CD containing technical documentation and all necessary software. The CD also includes an easy-to-use AR1000 configuration utility, which has a graphical user interface (GUI) that enables designers to test all user-configurable options with the AR1000 controllers.

Popular due to its low cost, acceptance of finger, glove or stylus-pen inputs, and overall ease of manufacturing and integration, resistive touch-sensing technology is suitable for applications such as mobile phones, industrial automation, retail point-of-sale, gaming/entertainment, and automobile navigation systems.

The AR1000 controllers provide universal 4-, 5- and 8-wire support, as well as support for SPI, I²C and UART communication interfaces, and are available in 20-pin QFN, SOIC and SSOP packages.



HOW TO ENTER

For your chance to win one of the *mTouch AR1000* Development Kits from Microchip, please visit: www.microchip-comps.com/epe-AR1000, and enter your details in the online entry form.

CLOSING DATE

The closing date for this offer is 30 April 2013

Get a million precisely selected resistance values with this . . .

6-Decade Resistance Substitution Box



By JIM ROWE

One of the most common tasks when trying out a new circuit is fine-tuning the resistance values. This task is made a lot faster, easier and more precise by this *6-Decade Resistance Substitution Box*. It's easy to build and gives you the ability to select from thousands of different resistor values between 10Ω and $10M\Omega$, just by twiddling the switches. When you have found the optimum, just read off the value on the switches.

YES, we know about those little 'resistor substitution wheel' gadgets, which you can pick up for around £15. Generally, they offer a selection of 36 different resistor values, covering a very wide range, usually between 5Ω and $1M\Omega$. They're OK, but you will usually find that the value you need is not present in that limited range of only 36 values.

Then you dive into your resistor stock and hope that you can find a value that

will work. We've all been there and know how frustrating it is to find that Murphy's Law is applicable – there are none left in the drawer concerned. In any case, you tend to end up with a motley collection of resistors on the bench, all of which have to be put back in their drawers afterwards. That's so boring.

Resistor substitution wheels have another drawback, which is that their internal resistors are usually only 5% tolerance. So, even if one of the 36

nominal values turns out to be suitable for the circuit you're working on, you still need to check the actual value with your DMM before making your final selection of the value to be used.

Resistance box

So what we really need is more like an old-fashioned 'decade resistance box', with a much larger selection of close-tolerance resistance values. But those old decade boxes were

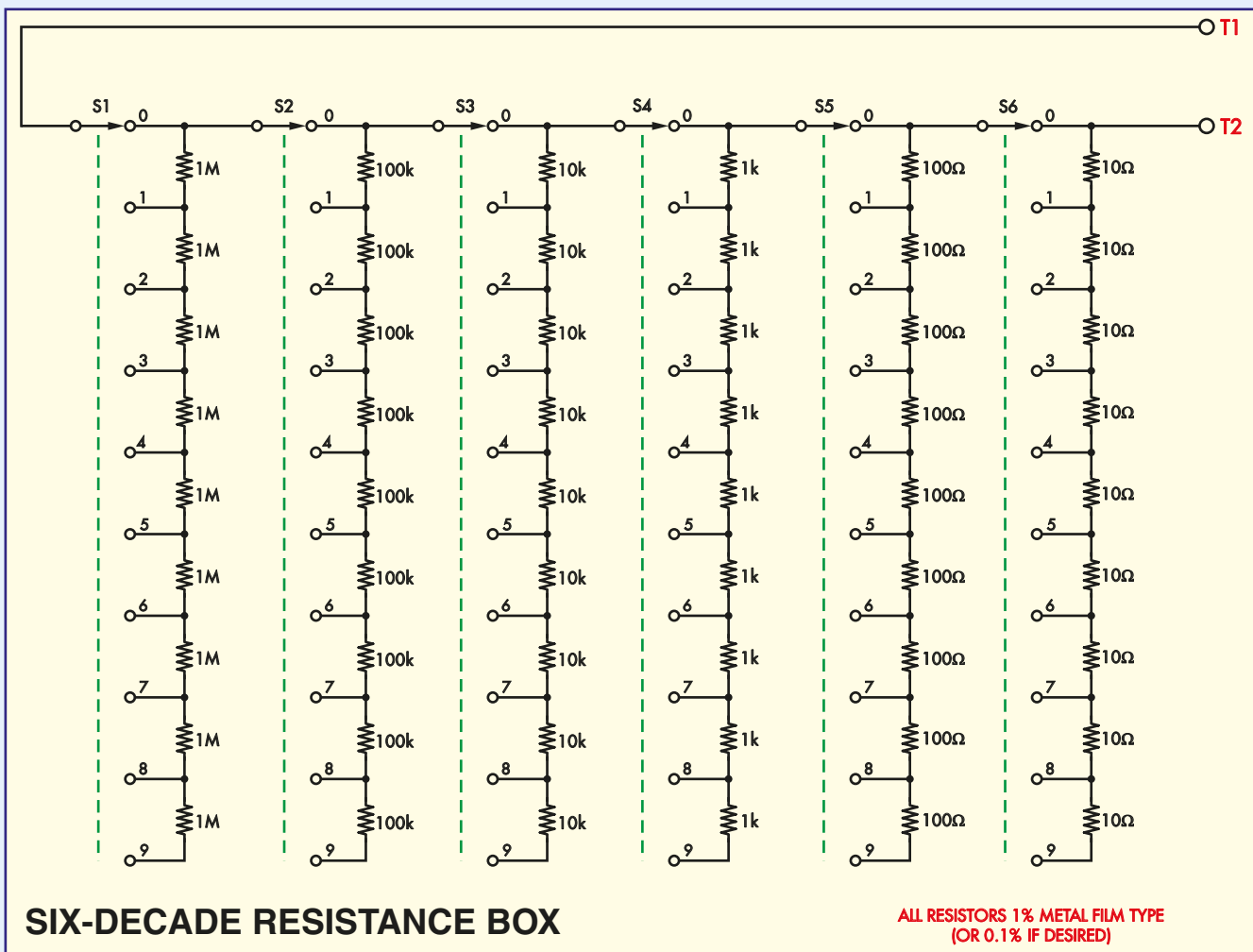

Fig.1: the circuit consists of six 10-position rotary switches (S1 to S6) in series with terminals T1 and T2. The associated resistor strings allow each switch to select a unique resistance value ranging from 0 to 9MΩ (S1) down to 0 to 90Ω (S6)

big, clunky and expensive. Even the latest models are quite expensive. OK, so why not build your own? We have produced a compact *6-Decade Resistance Substitution Box* using readily available rotary switches and 1% metal-film resistors, all mounted on a PCB (printed circuit board) to make assembly a cinch.

A million resistance values

This 'box' allows you to dial up a million resistance values between 10Ω and 10MΩ, selectable in 10Ω increments. It uses only 54 resistors, so if you use standard 1% metal film resistors they'll cost you less than a few pounds.

Add in the cost of a UB1-size plastic box, six standard rotary switches and knobs, a pair of binding post terminals and a PCB and it is still not pricey – a small fraction of the cost of a commercial decade box, in fact.

For even higher accuracy, you can use 0.1% metal film resistors instead of the 1% types. These will bump up the total cost to over £50, but it will still be much less than the price of a comparable commercial unit.

How it works

The circuit diagram, if you can call it that, is shown in Fig.1. Six 10-position rotary switches S1 to S6 are wired in series, between the two binding post terminals T1 and T2.

The resistors are connected in daisy-chain fashion around the six switches. Each click of switch S1 increases the total resistance by 1MΩ, while each click of switch S6 increments it by 10Ω.

Since all six switches are connected in series, you can dial up any resistance between 0Ω (all switches set to '0') and 9.99999MΩ (all switches set to '9'), in increments of 10Ω.

Mind you, while we said you can select a million different resistance values, in practice you would not use all six switches to select each resistance; that would be pointless. It all comes down to the tolerance of the resistors you are using. Even if all 54 resistors are 0.1% tolerance, you will quickly come to realise that if you use three consecutive decade switches to select a value, the three-digit resolution of the selected value is already equal to the tolerance of ±0.1%.

You also need to consider that the minimum resistance of the box with all switches set to '0' is not exactly 0Ω. That's because the contact resistance of the switches and the resistance of the PCB tracks does introduce a small amount of residual resistance – typically around 0.25Ω, or 250 milliohms.

In practice, this doesn't matter much and merely increases the error

Constructional Project

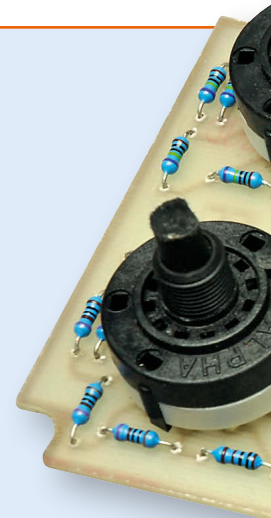
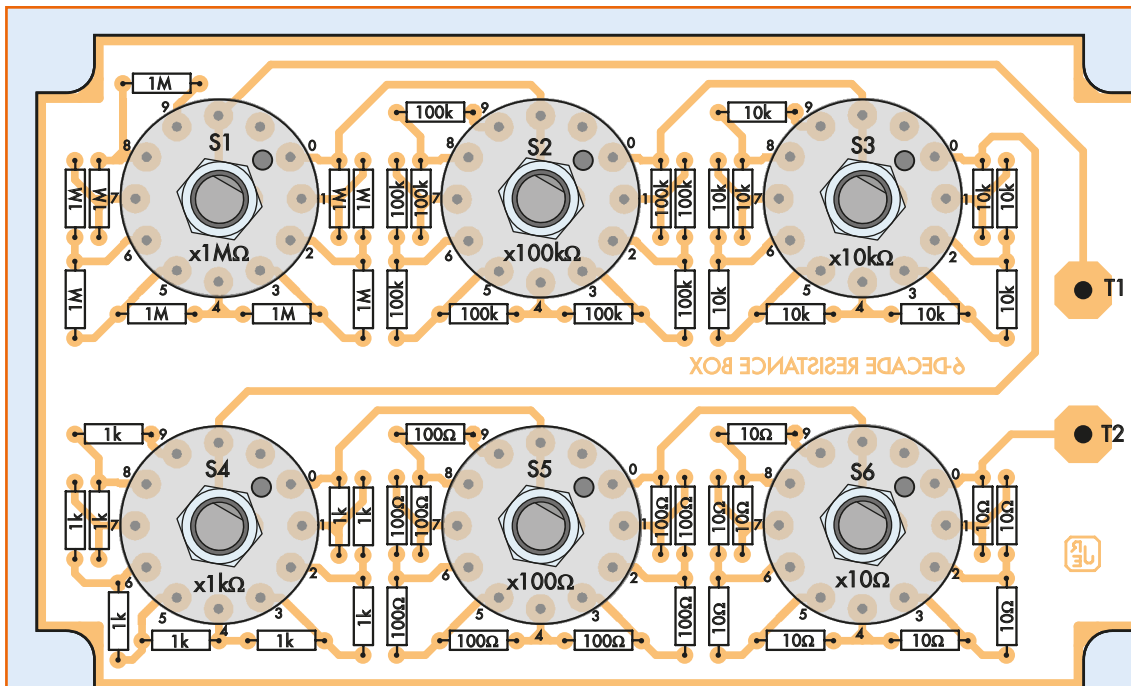

Fig.2: follow this parts layout diagram to build the 6-Decade Resistance Box. Note that the switches must be installed with their anti-rotation spigots oriented as shown. The tops of these spigots must also be removed using side cutters.

of the two lowest settings of S1 (10Ω and 20Ω) beyond the basic $\pm 1\%$ of all other ranges: about +3% for the 10Ω setting and +1.5% for the 20Ω setting.

We will discuss some of these points later. For now though, this 6-Decade Resistance Substitution Box is a very useful accessory and it is dead-easy to build.

Construction

All of the switches and resistors are mounted on the PCB, which mounts inside a standard UB1-size box. The complete PCB assembly is attached to the box lid – held there by the mounting nuts of the six switches.

The circuit board (size 146mm \times 87mm) is available from the EPE PCB Service, code 894.

The two binding posts are the only components not on the PCB; they are mounted on the lid itself, with their rear connection spigots connecting to the two large pads on the PCB when the latter is attached to the lid.

The PCB is single-sided, but we strongly recommend that you use a fibreglass PCB with a solder mask. This will reduce the possibility of leakage paths developing in the future, which could reduce the accuracy on the top resistance range.

Board assembly

The component overlay is shown in Fig.2. Fit the resistors first. There are only six different values: 10Ω, 100Ω, 1kΩ, 10kΩ, 100kΩ and 1MΩ, with nine of each, making 54 in total. Each value is clustered around its respective switch. **Don't mix up the values.**

Before fitting the rotary switches, cut the spindle of each switch to about 10mm long or just enough to suit the control knobs you are using. Make sure you remove any burrs from the top end of the spindles with a file, so that their knobs will slip on easily later.

All six switches are mounted on the board with the orientation shown

in Fig.2. As you can see, the moulded locating spigot on the front of each switch body is at '1:30', while each switch's rotor connection pin (not visible in Fig.2 or Fig.3) is in the '3:00' position, as viewed from the top.

Once all six switches have been fitted to the board and soldered in, it's a good idea to make sure that they are all set for a span of 10 positions. To do this, turn the switch spindle fully anticlockwise and then remove its mounting nut, star lockwasher and 'stop washer'. Then replace the stop washer with its stop pin passing down through the hole between the numbers '10' and '11', moulded into the switch body.

Replace the lockwasher and mounting nut. Then turn the switch spindle clockwise by hand and you should find that it can be moved through a total of 10 positions (0 to 9 inclusive).

You will also need to use a pair of side cutters to nip the plastic spigot off all the switches. If this is not done, the spigots stop the switches from mounting flush underneath the lid. Do this for all six switches.

It is also a good idea to use an old toothbrush and some methylated spirits to scrub off all solder flux residue from the underside of the PCB. This will remove any leakage paths which will otherwise reduce the accuracy of

Table 1: Element14 0.1% Resistors

1083036	10Ω metal film resistor	0.1% 0.25W	£7.10 (2 packs)
1751317	100Ω metal film resistor	0.1% 0.25W	£8.70 (2 packs)
1751444	1kΩ metal film resistor	0.1% 0.25W	£4.80 (2 packs)
1751550	10kΩ metal film resistor	0.1% 0.25W	£6.70 (2 packs)
1751658	100kΩ metal film resistor	0.1% 0.25W	£5.00 (2 packs)
1751718	1MΩ metal film resistor	0.1% 0.25W	£7.00 (2 packs)

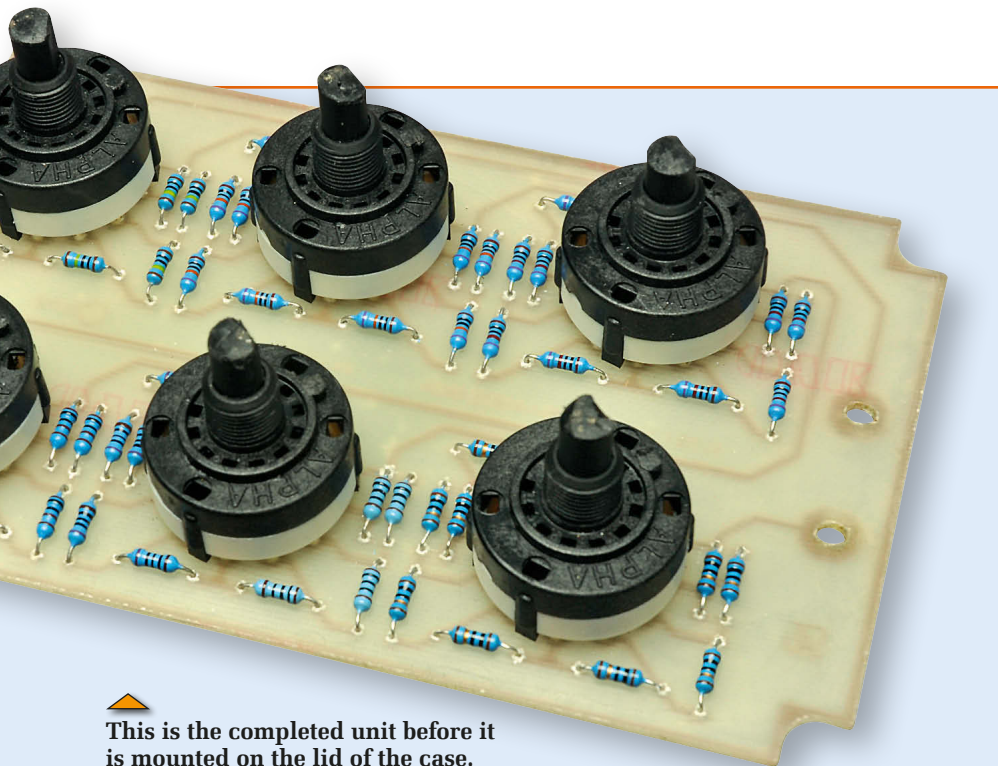

This is the completed unit before it is mounted on the lid of the case.

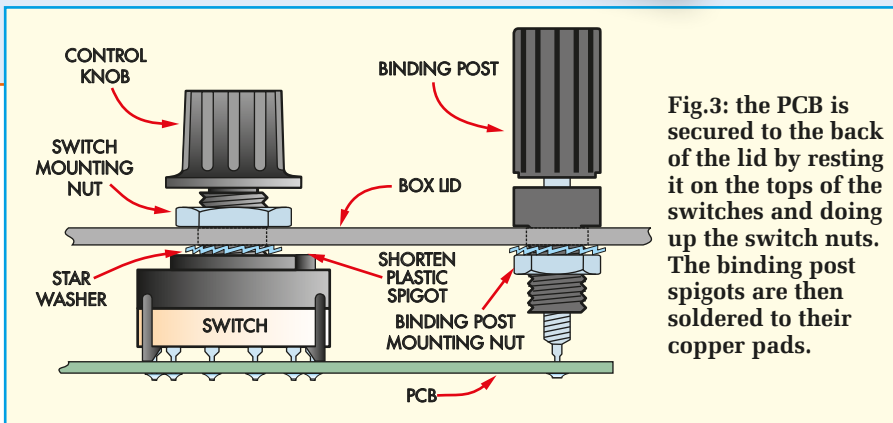

Fig.3: the PCB is secured to the back of the lid by resting it on the tops of the switches and doing up the switch nuts. The binding post spigots are then soldered to their copper pads.

the values selected when you are using the megohm range switch.

The PCB assembly can now be placed aside while you prepare the box.

Preparing the box lid

There are eight holes to be drilled and reamed in the box lid. There are six 10mm-diameter holes for the threaded ferrules of the switches, plus two 9mm holes for the binding posts.

You can use the front-panel artwork as a drilling template for the lid. They are not printed here, but can be obtained in PDF format from the downloads section of the *EPE* website, then photocopied and stuck to the lid.

Once the eight holes have been drilled and reamed to size, you can make a dress front panel by laminating another copy of the artwork. After this, you can fit the two binding posts to the panel, using the nuts and washers

supplied, as shown in Fig.3. The lid can then be lowered down until it's resting on the lockwashers for the switches. Fit the mounting nuts to each switch ferrule and this will hold everything together. The rear spigots of the binding posts can then be soldered to the matching pads of the PCB.

That done, place the lid/PCB assembly into the box itself and fit the four small self-tapping screws supplied, then push in the small rubber bungs to cover each screw head. Finally, fit the control knobs to each switch spindle.

Higher precision?

Earlier in this article, we mentioned that 0.1% tolerance metal-film resistors can be substituted for the standard 1% tolerance types, if you want your decade box to be significantly more accurate. These higher-precision resistors are available and are physically

Parts List

- 1 UB1-size box, 158mm × 95mm × 53mm
- 1 PCB, code 894, available from the *EPE PCB Service*, size 146mm × 87mm
- 1 dress front panel
- 6 single-pole rotary switches (S1 to S6)
- 6 19mm diameter control knobs, grub-screw fixing
- 2 black binding posts
- 4 adhesive rubber feet

Resistors (0.25W, 1% or 0.1% metal film – see text)

- | | |
|---------|--------|
| 9 1MΩ | 9 1kΩ |
| 9 100kΩ | 9 100Ω |
| 9 10kΩ | 9 10Ω |

Reproduced by arrangement with SILICON CHIP magazine 2013.
www.siliconchip.com.au

very similar to the standard 1% type – so there is no problem making this change.

But, be warned, that there is a significant extra cost involved – the 0.1% resistors will cost you around 50p to £1 each, compared with the pennies for 1% resistors. A set of 60 of these resistors will raise the cost of your decade box by around £40.

However, we think that the extra cost of high precision resistors is really well worth it. It is very satisfying to dial up a resistance value with two or three switches and then confirm that it's smack on the value (or very close to it) with your DMM. It means you can dial in preferred value resistors to a prototype circuit and know that you will get very similar results when you install the same physical resistor.

Sourcing 0.1% resistors

The 0.1% resistors available from Element 14 (formerly Farnell Components – www.element14.com) come in packs of five; you need to buy two packs of each value. Table 1 lists the values. The first number is the Element14 stock number, followed by the description and the cost.

Power rating

Finally, note that the power dissipation must not exceed more than 0.25W for the resistance value selected. This can be calculated using the formula $P = V^2/R$ or $P = I^2R$. **EPE**

When electronics go bad

TechnoTalk

Mark Nelson

A little knowledge is a dangerous thing, as evidenced by two recent news reports of major foul-ups involving seemingly basic electronics. Was the science bad or merely the way users applied it? Mark investigates.

EVERY now and again the appliance of science (or rather its application) goes awry. Some kind of lapse occurs, maybe a misunderstanding, and there follows a battle royale between the client (who misapplied the device) and the supplier (who assumed the user would read the data sheet and make an informed decision). All you need then is some non-technical reporters in the media to create a perfect storm.

Fortunately, most of these storms remain inside teacups and are soon forgotten by the public at large. But the acrimony often persists, as does any damage to corporate reputations and wealth. Let me explain...

Bad batteries ground 787s

Boeing hit the headlines for the wrong reasons in January this year when all airlines operating the company's new 787 *Dreamliner* were forced to ground their fleets. The cause was two very serious fires on board involving lithium-ion batteries. 'We have not ruled anything out as a potential factor in the battery fires; there are still many questions to be answered,' said US National Transportation Safety Board chairperson Deborah Hersman. 'One of these events alone is serious; two of them in close proximity, especially in an airplane model with only about 100,000 flight hours, underscores the importance of getting to the root cause of these incidents.'

To save weight and boost fuel efficiency, Boeing eliminated a lot of internal mechanics on the aircraft and used electronics powered by tailor-made battery packs located under the wings and cockpit. The faulty batteries, which play a crucial role in the plane's functioning, showed signs of short circuit and thermal runaway, leading to a destructive chain reaction.

Known problem

Over the years, similar problems have bedevilled several brands of laptop computers that use lithium-ion batteries, and in each case the problem has been production defects. To quote **HowStuffWorks.com**, the manufacturing process for these cells creates tiny pieces of metal that float in liquid. Manufacturers can't completely prevent these metal fragments, but good manufacturing techniques limit their size and number.

The cells of a lithium-ion battery also contain separators that keep the anodes and cathodes, or positive and negative poles, from touching each other. If the battery gets hot through use or recharging, the pieces of metal can move around, and may puncture the separator to cause a short circuit and heat generation. The larger the battery, the more destructive the damage. Worse, these fires typically generate oxygen and are very difficult to extinguish.

Cost cutting to blame?

Intrinsically safe lithium batteries do exist but they use different technologies (Li-MnO₂ or Li-SOCl₂) and are not as compact or cost-effective. The jury is still out on the *Dreamliner's* batteries; according to **ElectronicProducts.com** the fault may lie not in the battery itself but in the battery protection circuitry. The opinion of technology consultancy Lux Research is that there are known safety concerns with the lithium-cobalt oxide used in the 787's batteries, and that Boeing should have chosen lithium-iron phosphate, which, even when overcharged, prevents oxygen release and resists thermal runaway. It also notes that major car makers refused early on to entertain the possibility of using lithium-cobalt oxide in passenger vehicles due to safety concerns.

Regardless of all this, better understanding of battery technology and circuitry is important, not only for the future of the 787, but also for the *A350 Airbus* and the International Space Station (ISS), both of which have announced their intention to use identical or very similar Li-ion batteries from GS Yuasa Lithium Power.

Wrong kind of light

Sunflowers wilt: Van Gogh's masterpiece is slowly turning brown as a result of exposure to LED lighting. That was one of the shock headlines earlier this year, when it was revealed that scientists had discovered that the chrome-yellow pigment featured in paintings by Van Gogh and other famous painters was unstable under LED light and was turning an unwelcome shade of brownish green.

According to *The Independent* and other newspapers, researchers have now warned galleries and museums to reconsider the use of some LED lighting to prevent the colours in such

paintings deteriorating further. Said Claus Habfast, from the European Synchrotron Radiation Facility in France: 'LED lights appear to have many advantages, but museums should carefully consider that paintings from the Van Gogh era could be affected by them. Paintings that have moderate darkening will find this accelerates in the coming years. Of course, it's not advisable to put these paintings in the dark because they are part of our cultural heritage and the public wants to see them. But museums have to strike the right balance.'

This, of course, is exactly the news that galleries did not wish to hear, as LED lighting was thought to provide better protection for pictures by avoiding the harm caused by the effects of natural light (such as the fading cause by ultra-violet rays). LED illumination has, in fact, become an increasingly popular choice with art institutions in recent years, as an energy-efficient alternative to fluorescent light bulbs.

Never mind the facts...

By now the genie was out of the bottle and the story spread like wildfire. Only it was a complete load of tosh, at least according to Don Tuite on the **electronicdesign.com** website. Like Don, I have a mistrust of mainstream newspapers' coverage of deeply technical subjects, although unlike Don, I did not fork out \$35 to read the *Analytical Chemistry* paper that was cited as the source of the panic.

In fact, this report says the paint tests were conducted using a high-intensity xenon lamp, not with LED lamps. The warning to avoid using LED lamps comes only from Mr Habfast, without further scientific explanation. Nevertheless, the histrionic shock-horror story is still on *The Independent's* website.

Apricot soup

LED lighting is much appreciated by other art galleries of course. Curators at Indiana University Art Museum praise LEDs. The difference between the old-style incandescent lighting and the LED alternative is clear to see, with the paintings being illuminated by cooler and cleaner white lights. Referring to incandescent lamps, 'It's like apricot soup', commented IU professor Rob Shakespeare.

UK readers you can **SAVE 94p** on every issue of *EPE*

How would you like to pay £3.46 instead of £4.40 for your copy of *EPE* ?



Well you can – just take out a one year subscription and save 94p an issue, or £11.28 over the year. You can even save £1.15 an issue if you subscribe for two years – a total saving of £27.60.

Overseas rates also represent exceptional value.

You also:

- Avoid any cover price increase for the duration of your subscription
- Get your magazine delivered to your door each month
- Ensure your copy, even if the newsagents sell out

Order by phone or fax with a credit card or by post with a cheque or postal order, or buy online from www.epemag.com (go to the Online Shop).

EPE EVERYDAY PRACTICAL ELECTRONICS

SUBSCRIPTION PRICES

Subscriptions for delivery direct to any address in the UK: 6 months £21.95, 12 months £41.50, two years £78.00; Overseas: 6 months £25.00 standard air service or £35.00 express airmail, 12 months £48.00 standard air service or £68.00 express airmail, 24 months £91.00 standard air service or £131.00 express airmail.

Cheques or bank drafts (in £ sterling only) payable to *Everyday Practical Electronics* and sent to EPE Subs. Dept., Wimborne Publishing Ltd., 113 Lynwood Drive, Merley, Wimborne, Dorset, BH21 1UU. Tel: 01202 880299. Fax: 01202 843233. Email: subs@wimborne.co.uk. Also via the Web at: www.epemag.com.

Subscriptions start with the next available issue. We accept MasterCard, Maestro or Visa. (For past issues see the Back Issues page.)

ONLINE SUBSCRIPTIONS

Online subscriptions, for reading the magazine via the Internet, £19.99 for one year, visit www.epemag.com for more details.

SUBSCRIPTION ORDER FORM

- 6 Months: UK £21.95, Overseas £25.00 (standard air service), £35.00 (express airmail)
- 1 Year: UK £41.50, Overseas £48.00 (standard air service) £68.00 (express airmail)
- 2 Years: UK £78.00, Overseas £91.00 (standard air service) £131.00 (express airmail)

To: *Everyday Practical Electronics*, Wimborne Publishing Ltd., 113 Lynwood Drive, Merley, Wimborne, Dorset BH21 1UU
Tel: 01202 880299 Fax: 01202 843233
E-mail: subs@epemag.wimborne.co.uk

I enclose payment of £ (cheque/PO in £ sterling only), payable to *Everyday Practical Electronics*

Please charge my Visa/Mastercard/Maestro

My card number is:
Please print clearly, and check that you have the number correct

Signature

Card Security Code Valid From Date.....
(The last 3 digits on or just under the signature strip)

Card Ex. DateMaestro Issue No.

Name

Address

Post code Tel.

Subscriptions can only start with the next available issue.





Building our new

Part 3: By JIM ROWE

SemTest

Now that we have the full circuit diagram of our new *Discrete Semiconductor Test Set*, it's time to describe its construction and the set-up procedure. We also describe how to fit a crowbar circuit to quickly discharge the HT after making high-voltage measurements.

AS SHOWN in the photographs, the *SemTest* is built in an ABS enclosure measuring 222mm × 146mm × 55mm. Apart from VR10 (the MOSFET V_{GS} pot) and the five pushbutton switches (which mount directly on the front panel), all the components are mounted on one of two PCBs.

Both boards are double-sided, so there is no need to fit any wire links. Incidentally, our prototype had numerous link positions on both boards. These have now been incorporated into the copper patterns on the top layers of both boards, so that's one less tedious task to be done.

The main board (coded 890) mounts in the bottom of the enclosure, while

the display board (coded 891) sits behind the front panel and is spaced 18mm from it. The two boards are linked via three flat ribbon cables fitted with IDC connectors.

Rotary switch S2 is mounted on the lower PCB. Its control shaft is 42mm long, so that when the case is assembled, it passes through clearance holes in both the display PCB and the front panel.

Power switch S1 and 12V input connector CON1 are both located on the right-hand end of the main board, towards the rear, and pass through holes in the right-hand end of the enclosure. A small hole nearer the front of the

enclosure provides access to trimpot VR2, which is used to set the micro's 2.490V reference voltage.

Six similar holes along the top edge of the right-hand end of the enclosure are used to access various trimpots mounted on the right-hand end of the display board.

Main PCB assembly

Use the layout diagram of Fig.10 as a guide to assembling the main board.

Begin construction by fitting all the smaller resistors, which should be 1% tolerance. Note that one of these resistors (which mounts about 20mm above and to the right of IC3) is marked

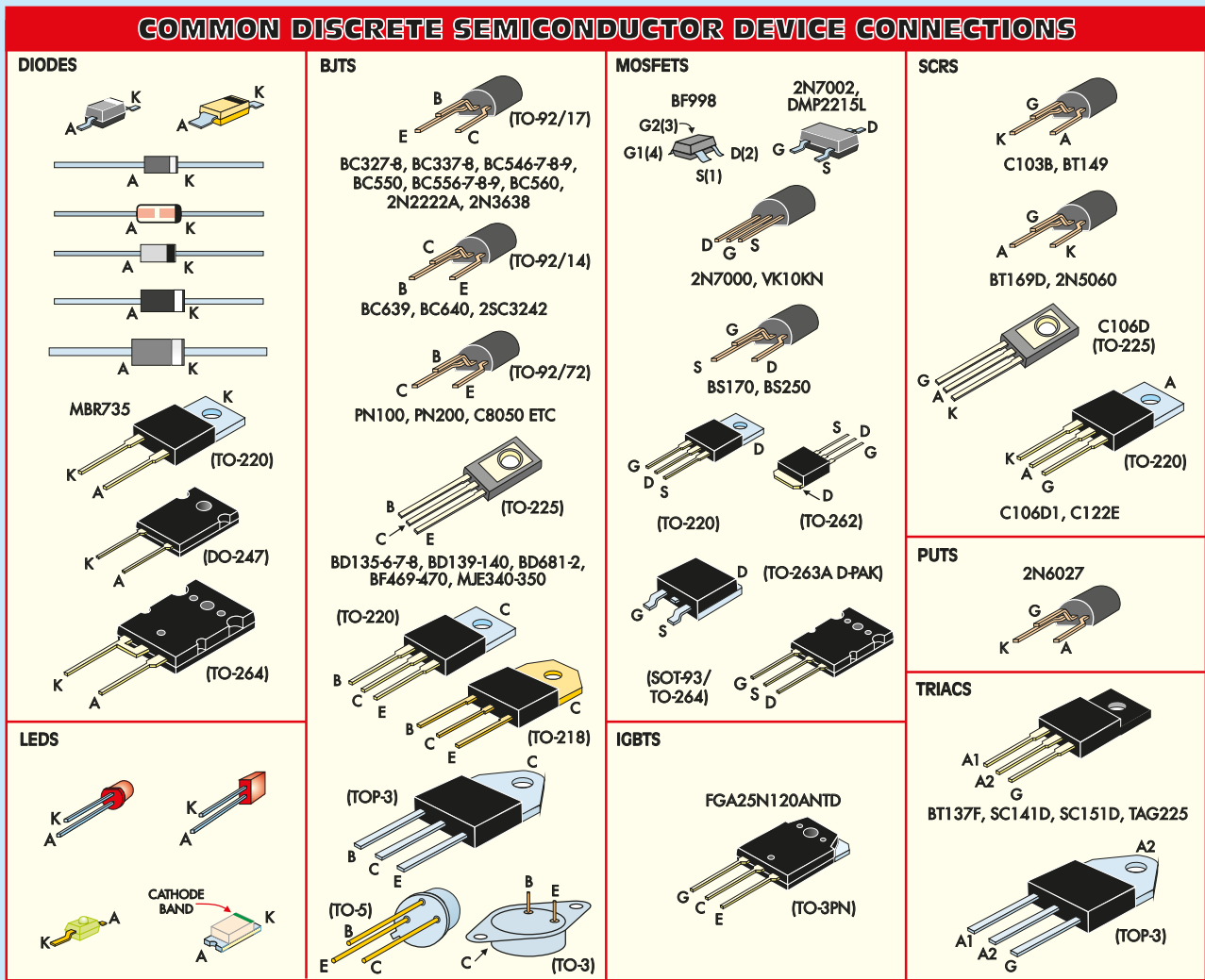

This handy table shows the pin connections for many discrete semiconductor devices. The ZIF socket on the front of the *SemTest* makes it easy to connect devices for testing.

'0Ω/68Ω', because its value depends on the type of relay you use for Relay 1.

If you use a relay with a 12V coil, this resistor can be replaced with a wire link (or zero-ohm resistor). With a 6V relay, the resistor should be 68Ω.

The 1W and 5W resistors are next. Mount the 5W resistors about 1.5mm above the surface of the board, to allow some ventilation if they become hot in operation.

Follow with trimpots VR1 and VR2. VR1 (50kΩ) mounts near IC1, while VR2 is a horizontal multiturn 10kΩ pot, which mounts at lower right.

Once these are in, fit the capacitors. The two 47μF 450V electrolytics need to be laid on their sides and secured with small cable ties.

Now fit the DC input connector CON1, followed by power switch S2, DIL pin headers CON2, CON3 and

CON4, the 40-pin DIL socket for IC4 and the 8-pin DIL sockets for IC1 and IC3. Relay drivers IC5 and IC6 do not need sockets, and are soldered direct to the PCB later during the assembly.

The six 1mm PCB terminal pins, used for the various test points can now go in. The four relays can then be installed. Note that RLY7 and RLY8 are mini-DIL reed relays, which should be mounted with the orientation shown in Fig.10.

Step-up transformer

The next step is to wind T1, the step-up transformer for the *SemTest's* DC-DC converter. The winding and assembly details are shown in Fig.11; follow this exactly (or else!). Wind each layer as closely and evenly as possible; wind them all in the same direction and cover each layer with a

layer of insulating tape (to both hold that layer in place and provide insulation between it and the layer above it).

Before T1 is assembled, don't forget the 'gap' washer, cut from a small piece of 0.06mm-thick plastic sheet.

Transformer T1 can now be mounted on the main PCB. It is held in place (as well as being held together) by an M3 × 25mm long nylon screw and nut. Note that the primary start (S), tap (T) and secondary finish (F) wires all connect to the PCB, just to the right of the transformer itself.

Semiconductors

Now for the semiconductors, starting with the diodes and Zener diodes. Make sure that these are all installed the correct way around. The same goes for transistors Q1 and Q2. Make sure Q1 is a BC337 and Q2 is a BC327. Note

HT crowbar – a safety refinement

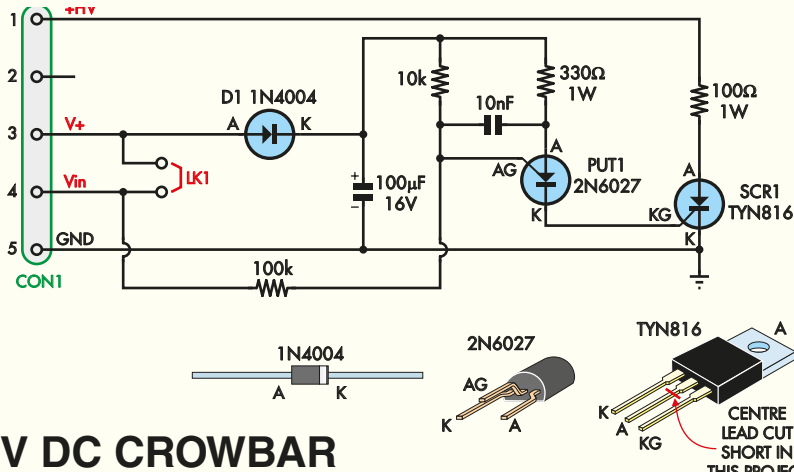

HV DC CROWBAR

Fig.7: the circuit monitors the converter's power supply rail in the *SemTest* and when V_{in} drops below 6V, PUT1 and SCR1 turn on to discharge the 47µF capacitors across the high-voltage output.

SINCE producing our prototype *SemTest* presented in the February and March issues, we have developed a further refinement – an add-on crowbar module which instantly

Parts List – HV DC Crowbar

- 1 PCB, code 897, size, 56mm × 40.5mm (available from the *EPE PCB Service*)
- 1 M3 × 6mm machine screw and nut
- 2 M3 shakeproof washers
- 1 100mm length red heavy duty mains-rated hook-up wire
- 1 200mm length black heavy duty mains-rated hook-up wire
- 1 200mm length yellow hook-up wire
- 1 70mm length 30mm diameter heatshrink tubing

Semiconductors

- 1 TYN816 SCR (SCR1)
- 1 2N6027 PUT (PUT1)
- 1 1N4004 1A diode (D1)

Capacitors

- 1 100µF 16V radial electrolytic
- 1 10nF monolithic multi-layer ceramic

Resistors (0.25W, 1%)

- 1 100kΩ
- 1 330Ω 1W (5%)
- 1 10kΩ
- 1 100Ω 1W (5%)

kills the high voltage applied to the ZIF socket at the conclusion of any breakdown voltage test. As a further safety measure, it also kills the high voltage in the event that the *SemTest* is inadvertently turned off before a test has properly concluded.

This minimises the chance of the user getting a shock from the test terminals when removing the DUT or a possible breakdown of the DUT itself when the power is inadvertently removed.

The crowbar module is wired to three points on the main (lower) *SemTest* PCB. On our prototype, these wires have been soldered to specific component leads, but the final *SemTest* PCB has pads for these wires.

The crowbar board senses the 11.4V supply rail to the MC34063 DC/DC converter IC1. This drops very quickly to around 6V when a test finishes or more slowly if the unit is switched off during a test. Either way, this is the trigger for the crowbar to discharge the capacitor bank from 600V to a few volts in around 20ms.

Circuit description

The full crowbar circuit is shown in Fig.7. It could potentially be used in other devices, but for use with the *SemTest*, link LK1 is installed, to short V_{in} (the sense input) and $V+$ (its power supply) together.

The +HV and GND terminals at CON1 are connected across the *SemTest*'s high voltage capacitor bank. Fig.8 shows a fragment of the *SemTest* circuit and demonstrates how the crowbar module is connected. The $V+$ terminal goes to pin 6 of IC1, which is at around +11.4V when the DC/DC converter is running and drops to 0V when it is switched off.

While the DC/DC converter is running, current flows from this rail, through diode D1, charging the 100µF capacitor. As this capacitor charges, the gate (AG) of programmable unijunction transistor PUT1 is pulled up too, via the 10kΩ and 100kΩ resistors.

At the same time, the anode (A) is pulled up via a 330Ω resistor. The 10nF capacitor between PUT1's anode and gate is initially discharged and this helps to keep the gate at anode potential, preventing false triggering if there are any initial glitches in IC1's power supply (eg, due to relay contact bounce).

A PUT is essentially a small anode-gate SCR. While a conventional SCR is turned on when its gate is pulled above its cathode (K), a PUT turns on when its gate is pulled below its anode, sinking current from the gate. Both SCRs and PUTs remain on once triggered, until their anode-cathode current flow drops below the 'holding' current, in this case much less than a milliamp.

As long as $V+/V_{in}$ are held at around 11.4V, the crowbar circuit remains deactivated. But once V_{in} drops precipitously, the 10nF capacitor begins to charge while the 100µF capacitor retains its charge, by virtue of diode D1.

Once V_{in} drops below the ~6V threshold, sufficient current flows from PUT1's gate to trigger it on. It then dumps the charge in the 100µF capacitor into SCR1's gate (KG), via the 330Ω current-limiting resistor. This happens in less than 100µs if V_{in} drops fast, as when a test ends normally.

The 330Ω resistor limits the current into SCR1's gate to around 25 to 30mA, enough to trigger it reliably.

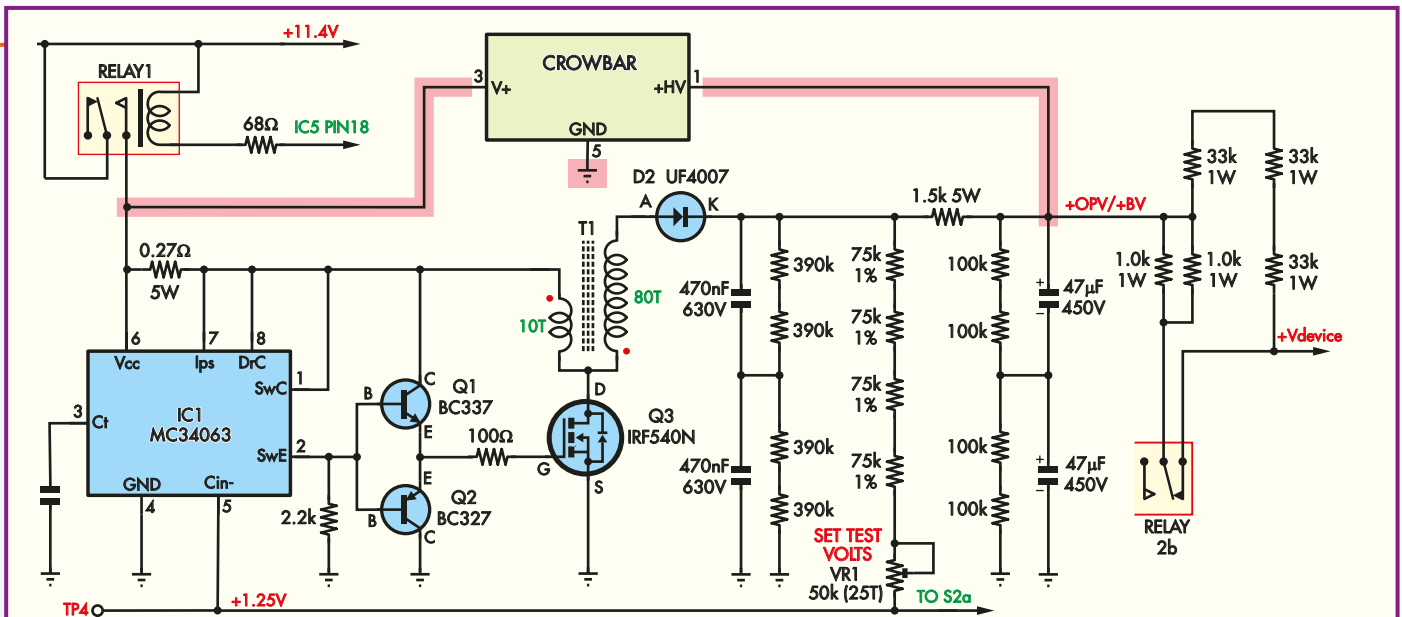

Fig.8: this diagram shows how the HV DC Crowbar module is connected to the *SemTest* circuit. Only three connections are required, as indicated by the lines highlighted in red.

SCR1 then rapidly discharges the high voltage capacitor bank through the 100Ω resistor. The peak discharge current is 600V/100Ω = 6A.

PUT1 switches off as soon as it has finished dumping the charge of the 100μF cap into SCR1's gate. But SCR1 stays on until the current through it drops below 40mA (its holding current) so the capacitor bank discharges to around 4V.

The specified TYN816 SCR is rated for 800V and 16A. Do not use an SCR with lower ratings.

Construction and testing

Refer to the overlay diagram, Fig.9. Fit the two small resistors first, followed by diode D1, with its cathode stripe towards the right side of the board. Use a lead off-cut for link LK1 and solder it in place. Then install the two 1W resistors.

Wiggle the middle lead of SCR1 back and forth until it snaps off. If there is any lead remaining, remove it with side-cutters. Bend the remaining two leads down and insert them through the holes on the PCB, then use the machine screw to attach the metal tab with a shakeproof washer, both under the screw head and under the nut. Do it up tightly

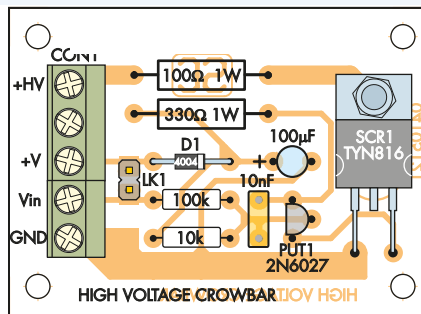
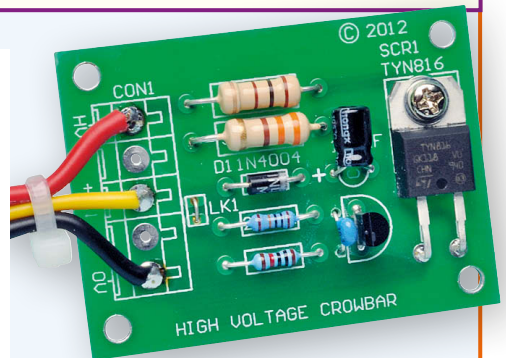

Fig.9: follow this layout diagram and photo to build the HV Crowbar. For the *SemTest*, leave out the screw terminal block and install a wire link for LK1.



since the screw conducts the current when the crowbar activates. Then solder the two pins.

Fit the 10nF capacitor and then PUT1, bending its leads out with pliers to suit the pad spacing. Push it down as far as it will go before soldering and trimming the leads. Next, mount the 100μF capacitor, with its longer (positive) lead towards the left side of the PCB. Bend its leads so that it lays down flat on the board before soldering them – see photo.

Don't fit a terminal block for CON1, since we have limited clearance to fit the unit into the *SemTest*. Instead, solder a red wire to HV, a yellow wire to V+ and a black wire

to 0V. Make sure there are no stray copper strands.

Wire the unit up to the *SemTest* as shown in the main overlay diagram (Fig.10). Trim each lead so that you don't have a lot of extra length. The photos show the best place to fit it.

Once it's wired up, slip the crowbar module into the heatshrink tubing and apply gentle heat. Make sure there is no exposed metal when you are finished. Some silicone sealant can then be used to hold the unit in place, so it doesn't rattle around inside the case.

Once the *SemTest* unit itself is complete, the HV crowbar must now be tested for correct operation, as described in the main article.

that IC7, the metering voltage reference IC, is in the same TO-92 package as Q1 and Q2 – be careful not to install it in the wrong position.

Two devices come in TO-220 packages – REG1, the 7805 5V regulator, and Q3, the IRF540N switching MOSFET. Both are mounted with their

leads bent down by 90° at a distance of 6mm from their bodies, so they pass down through the corresponding holes in the board to be soldered. Both

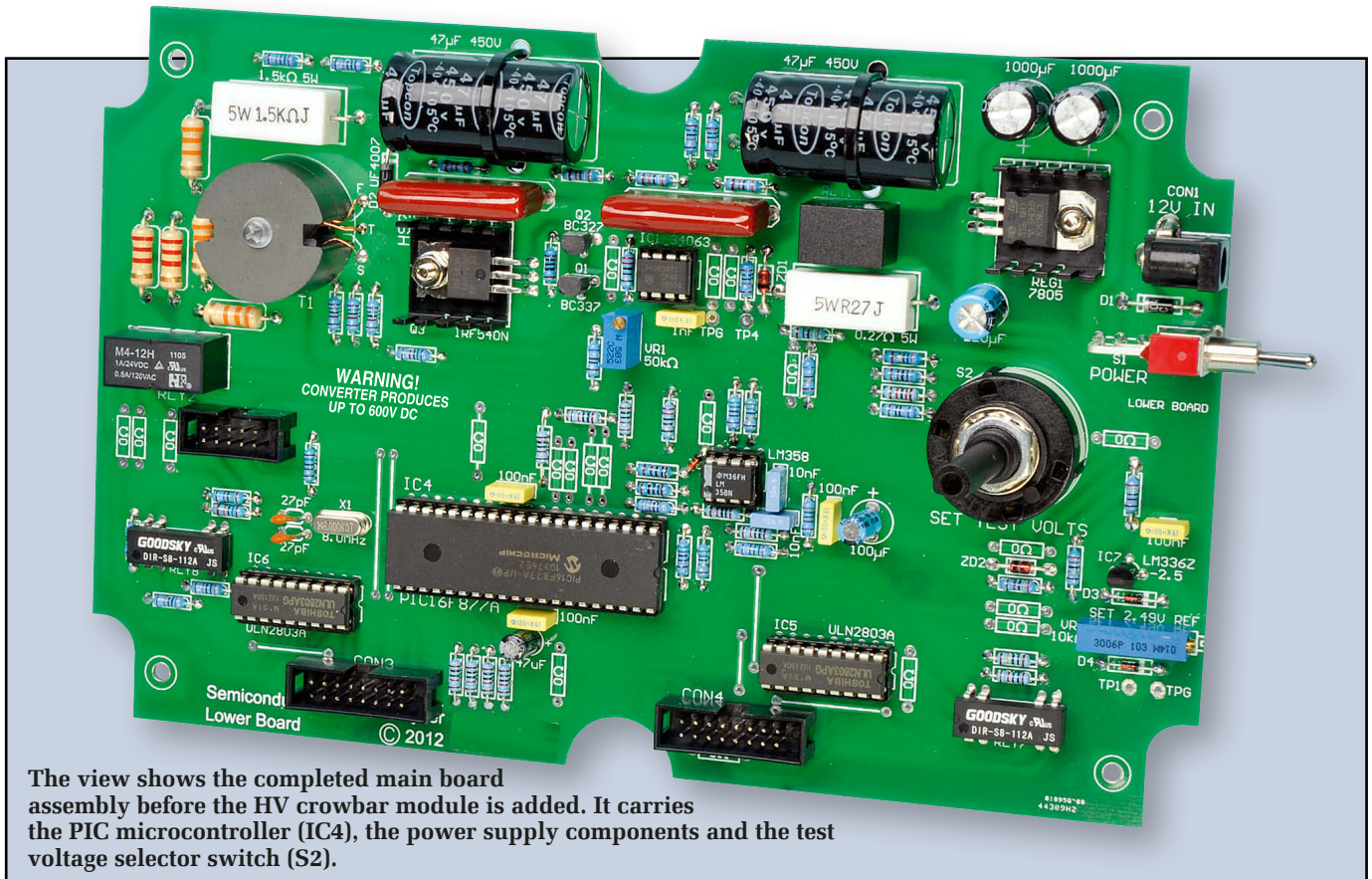

The view shows the completed main board assembly before the HV crowbar module is added. It carries the PIC microcontroller (IC4), the power supply components and the test voltage selector switch (S2).

devices are mounted on standard 19mm-square U-shaped finned heatsinks and secured using M3 × 10mm machine screws and nuts.

Having installed the semiconductors, install crystal X1. It's mounted just to the left of IC4's socket. That done, install the 3-pole 4-position rotary switch. **This switch must have a 42mm-long shaft and the one to use is a metric switch made by Lorlin (CK1051). We sourced ours from Element14 (Cat. 1123697 – www.element14.com).**

IC5 and IC6 can then be soldered in place and IC1, IC3 and IC4 plugged into their respective sockets. The main PCB assembly can then be completed by wiring the HV crowbar PCB to it, as shown in Fig.10.

Display PCB assembly

The component overlay for the display PCB is shown in Fig.12. Begin construction by fitting the resistors. As before, two of these are shown with a value of 0Ω/68Ω, to suit 6V or 12V mini SPDT relays: with a 6V relay, use a 68Ω resistor; for a 12V relay, use a wire link.

The seven trim pots can now go in; VR11 is a 10kΩ mini horizontal type near relay RLY3. The remaining six multiturn trim pots have values of 5kΩ and 10kΩ; don't mix them up.

VR10, the 10kΩ dual-gang pot, is wired with short flying leads and will be bolted to the front panel later. Note that it should have its shaft cut to a length of 15mm, to suit the knob.

Follow with the two capacitors and the relays. Make sure the two mini-DIL reed relays are correctly oriented, as you would for DIL ICs.

Now fit the semiconductors. There are four TO-92 devices: transistors Q4 and Q5 and voltage references IC8 and IC9; don't mix them up. Don't fit LED1 at this stage; do it just before the display PCB is attached to the front panel.

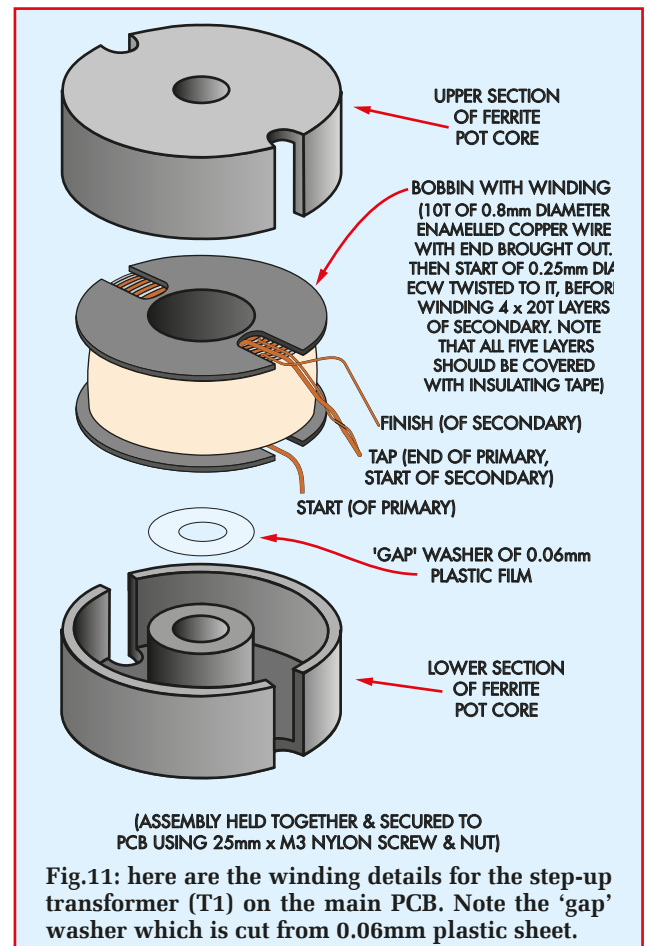
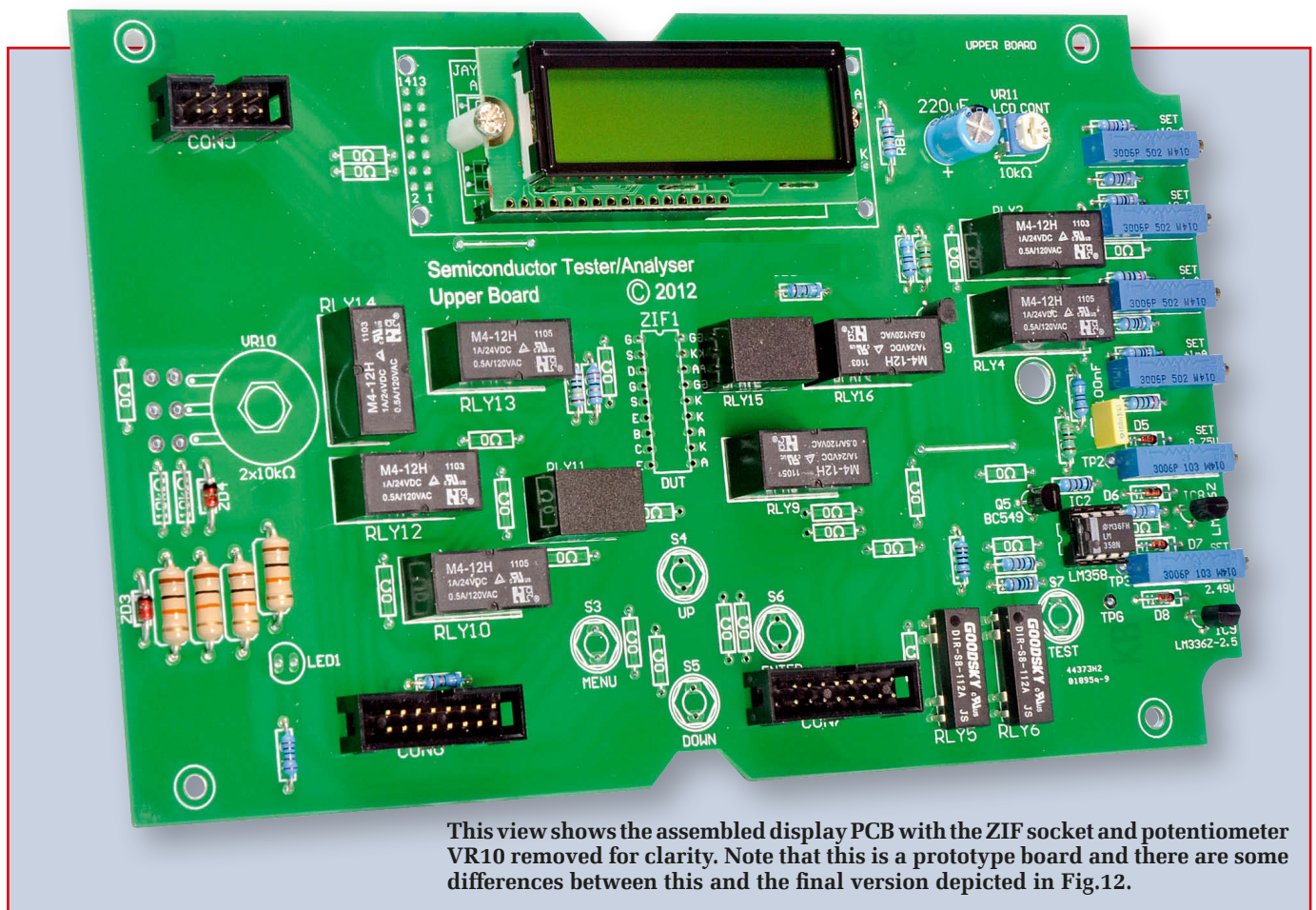

Fig.11: here are the winding details for the step-up transformer (T1) on the main PCB. Note the 'gap' washer which is cut from 0.06mm plastic sheet.



This view shows the assembled display PCB with the ZIF socket and potentiometer VR10 removed for clarity. Note that this is a prototype board and there are some differences between this and the final version depicted in Fig.12.

The three DIL pin headers CON5, CON6 and CON7 are next, followed by the 8-pin DIL socket for IC2. Then fit the four PCB terminal pins near IC2.

ZIF socket

Next comes the ZIF socket. It's not mounted directly on the board, but needs to be 'jacked up' so that it will protrude through the matching hole in the front panel. The ZIF socket also needs to clear the front panel by almost 8mm, to allow its actuator lever to swing down into the horizontal position.

Fig.13 shows how two 18-pin DIL sockets, piggy-backed together, are used to mount the ZIF socket. Most of the 'jacking up' is done by an 18-pin DIL IC socket with long wire-wrap tails. However, because the machined clips of this type of socket are not able to accept the rectangular pins of the ZIF socket, we have to use a 'production' type 18-pin DIL socket (having bent sheet metal clips) between the two, as an adaptor.

The ZIF socket is plugged into this intermediate socket first and the two are then plugged into the machined-clip socket. After this, the 3-socket

assembly is held together using fillets of epoxy adhesive – see Fig.13.

When the epoxy cement has cured you can fit the whole ZIF socket assembly to the display PCB. Note that the assembly should be installed with the actuator lever towards the LCD module position on the PCB.

Make sure that the bottom of the ZIF socket itself is exactly 18mm (or 19.5mm if you are using a PCB front panel) above the top surface of the PCB before you solder the 18 wire-wrap pins of the bottom socket to the pads on the PCB.

You can ensure this by using an 18mm-wide strip of stout cardboard underneath the assembly as a temporary spacer. It's best to initially tack-solder one pin at either end, then do a final check of the spacing and vertical positioning. This will allow you to make any last-minute adjustments that may be necessary before soldering the remaining 16 pins.

LCD module

The next step is to mount the LCD module – see Fig.14. The connections between this module and the PCB are made via a 16-way section of SIL pin header strip, which should be fitted

to the PCB (long pin sides uppermost) before the module is attached. Don't solder its pins at this stage, though.

The module itself is mounted on the PCB on two M3 × 6mm tapped nylon spacers. These are secured using M3 × 15mm machine screws which pass up from under the board, with a nylon flat washer under each screw head. The LCD module is then carefully slipped down over the screws, with the SIL strip pins passing up through the matching holes at bottom left.

M3 nuts are then fitted to the top ends of the screws to fasten the module in position, after which the bottom ends of the SIL strip pins are soldered to the display PCB pads underneath. Finally, their top ends are soldered to the pads on the top of the LCD module.

Use a fine-tipped iron for this job, and solder as *quickly* as possible to prevent heat damage.

Once the LCD module is in position, fit LED1 to the display board. It's mounted at lower left, with its cathode flat side to the left. At this stage, just tack-solder its leads temporarily to the board pads, with the lower surface of the LED body about

16mm above the board. This will enable you to adjust its final height above the board after it's attached to the front panel.

Now plug IC2 into its socket at lower right. That completes the assembly of the display board.

Making the ribbon cables

The details of these are shown in Fig.15. The two 16-way cables are cut from 120mm lengths of ribbon, with 15mm at each end to loop through the top of the IDC connector, leaving approximately 90mm of ribbon between the connectors.

The 10-way cable is made from a 190mm length of ribbon, with 15mm again used at each end for the connector loops. This leaves approximately 160mm of cable between the connectors. When you're fitting the IDC connectors to each end of the cables, make sure you fit them with the orientation shown in the circled details in Fig.15.

Preparing the case

If you are building the *SemTest* from a kit, the case will probably be already laser-cut and screen printed. If you are working from scratch, you will need to download the drilling/cutting diagrams from the downloads section of the *EPE* website and print these out to use as drilling templates. (They are not printed here.)

Take care when you are cutting the rectangular holes in the lid of the case for the ZIF socket and the LCD window because any curved or out-of-square edges will be painfully obvious when your *SemTest* is finished. The best approach is to first drill a series of 2.5mm holes around the inside perimeter of each rectangle and then use small jeweller's files to complete the job.

The easiest way to prepare the six notch holes along the upper edge of the right-hand side of the case (and the matching edge of that end of the lid) is to first temporarily fit the lid to the case. You can then drill the holes in both at the same time, using a 2mm drill to first make pilot holes and then enlarging these holes with a 4mm drill.

Front panel

If you are working from a kit, the lid is likely to be already screen-printed with the label. If not, you can purchase a PCB dress panel from SILICON CHIP. It is secured to the front panel with the same screws which mount the display PCB.

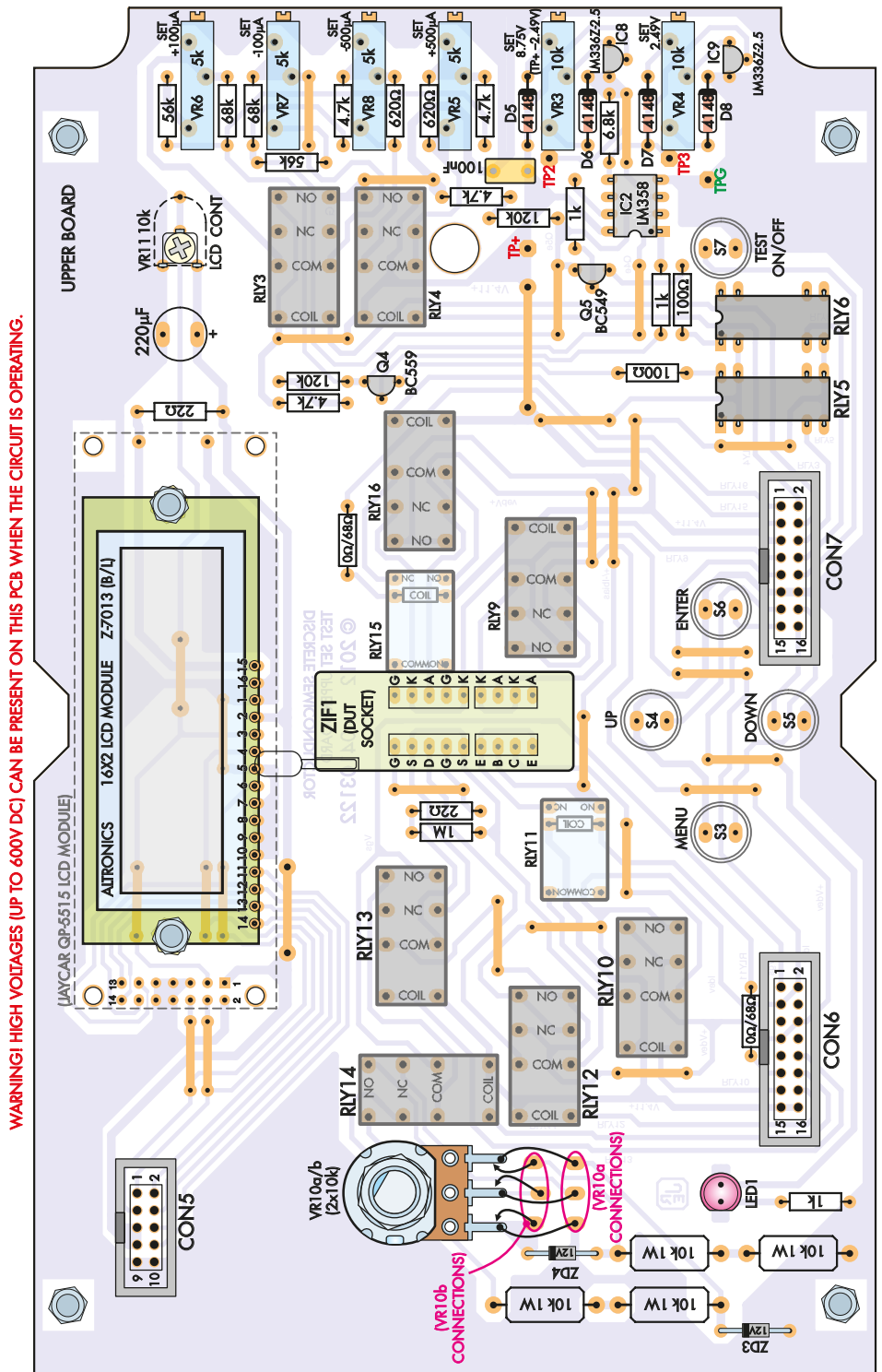

Fig.12: the display (top) PCB assembly. This PCB carries the ZIF socket, the LCD module and most of the relays and is connected to the main board via IDC cables.

Cut a 70mm x 25mm rectangle of clear plastic sheet and fasten this to the lid, behind the 51mm x 16mm rectangular cutout for the LCD viewing window. This will protect the LCD from dust and moisture. The plastic sheet can be fastened to the underside of the lid using cellulose tape around its edges.

Now mount pushbutton switches S3 to S7 on the front panel. That done, fit

the four M3 x 25mm machine screws, which ultimately attach the front PCB to the rear of the front panel.

As shown in Fig.14, each screw is fitted with an M3 x 15mm tapped spacer. The screws and spacers should be tightened as securely as you can, without causing the screw head to distort the label front panel. An M3 nut is then added to each screw at the

Constructional Project

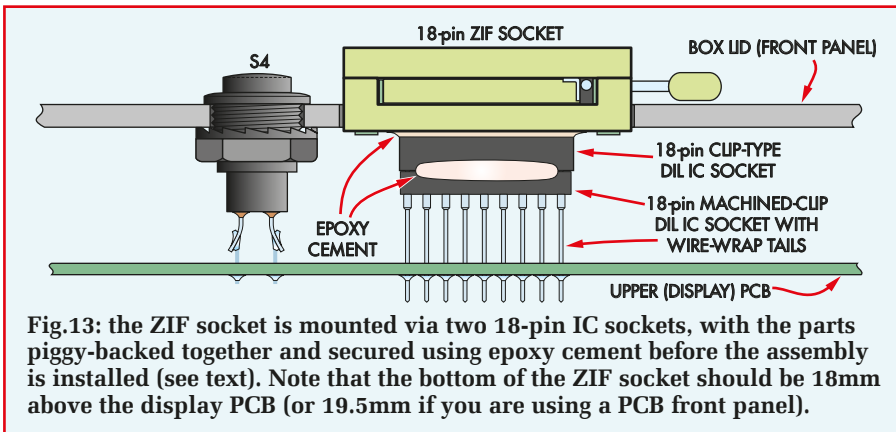

Fig.13: the ZIF socket is mounted via two 18-pin IC sockets, with the parts piggy-backed together and secured using epoxy cement before the assembly is installed (see text). Note that the bottom of the ZIF socket should be 18mm above the display PCB (or 19.5mm if you are using a PCB front panel).

end of each spacer to bring the effective spacer length close to 18mm.

Next, solder 'extension wires' to the connection lugs on pushbutton switches S3 to S7. The extension wires for these switches should all be made from 0.5mm diameter tinned copper wire, with their lengths staggered between about 40mm and 60mm, as later this will make it easier to pass them through their matching holes in the upper PCB.

You now need to solder some short flying leads (about 50mm long) to the terminals of dual-gang potentiometer VR10. The other ends of these leads can then be soldered to the PCB, as shown in Fig.12.

That done, temporarily stick the back of the pot to the display board with its shaft sticking up, ready to pass through the front panel. You can use some BluTac or double-sided tape for this job.

The three IDC cables should now be plugged into CON5, CON6 and CON7. The next operation is a bit tricky, because you have to dress each of the extension wires from switches S3 to S7 so they all go through their respective holes in the display PCB as it is moved up towards the rear of the front panel. You also have to pass the body of the ZIF socket (with its actuator lever vertical) up through its cutout in the panel,

and make sure that LED1 and VR10 are lined up to pass through their clearance holes in the front panel.

When you have managed to mate the two together, with the PCB fitted on to the ends of the four mounting screws, you can add a further nut to each screw to hold it all together. Tighten each nut to complete the job.

Once it's in position, solder all of the extension wires from switches S3 to S7 to their pads on the underside of the PCB. Be sure to trim the excess leads after the wires are soldered.

Now mount the main board in the case, but don't fit the lid/upper board assembly to the case just yet. It can be stood up near-vertically just in front of the case, with the front panel buttons and LCD display quite accessible.

Next, plug the free ends of the three ribbon cables into CON2, CON3 and CON4 on the main board. The unit is now ready for testing.

Setting up

Be careful when testing *Semtest*, as high voltages (up to 600V DC) can be present on both PCBs (see panel).

Start by setting the voltage selector switch S2 to its 50V position, then connect the *SemTest* to a 12V DC plugpack rated at 900mA or more, and turn on

power switch S1. There should be no test devices plugged into the ZIF socket as yet. You should see this initial greeting message in the LCD window:

SC Discrete Semi conductor Tester

which should be replaced after a couple of seconds with this message:

Press Menu Select button to begin:

If you only see a clear window or two lines of 16 black rectangles, it probably means that the contrast trimpot VR11 needs adjustment. Adjust it in one direction or the other until you see the messages displayed clearly and with good contrast.

Once this has been done, you can use your DMM to check the voltages at the input and output pins of REG1 (at upper right on the main board, just to the left of CON1). With the DMM's negative lead connected to the TPG pin just below D4 on the same PCB, you should get a reading of about 11.4V on REG1's upper input pin and a reading very close to 5.00V at its lower output pin.

Finishing the set-up

Your *SemTest* is now ready for the final setting-up adjustments. Do the adjustments in this order:

- Adjust trimpot VR2, at lower right on the main board, to set the PIC micro's ADC reference voltage to 2.490V. It's adjusted while monitoring the reference voltage with your DMM, across terminal pins TP1 and TPG, just below D4. This calibrates the *SemTest* ADC module's voltage and current measurement ranges.
- Adjust trimpots VR3 and VR4, at lower right on the display board. VR3 sets the voltage drop across IC8 to 2.490V, while VR4 is used to set the

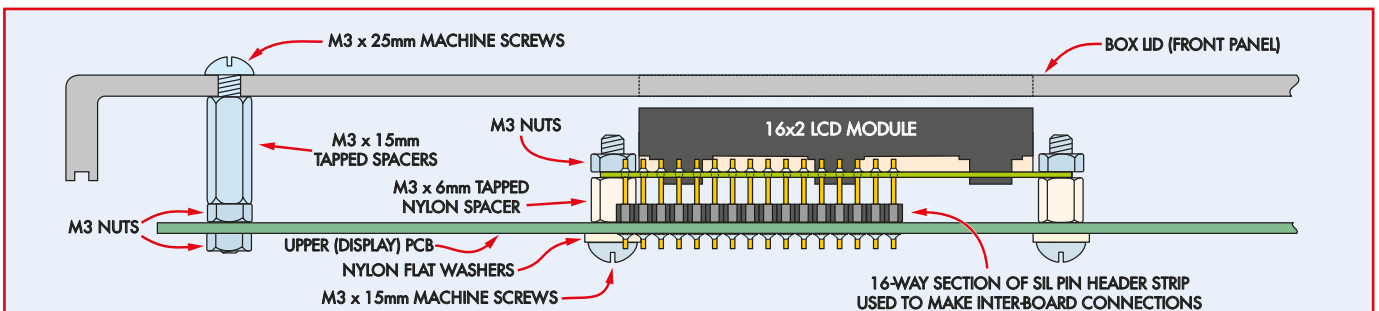

Fig.14: this diagram shows the mounting arrangement for the LCD module. It's mounted on four M3 x 6mm tapped nylon spacers, with the holes along one edge mating with the pins of a 16-pin SIL header strip that's soldered to the display PCB. Secure the LCD module in place before soldering it to the header pins along the top. The PCB itself is mounted on the box lid using M3 x 15mm spacers, with M3 nuts used to provide additional spacing.

drop across IC9 to the same figure. IC8 is the voltage reference for the $+I_{BIAS}$ current source, while IC9 does the same job for the $-I_{BIAS}$ current source.

To do this, connect the DMM leads between TP+ (+) and TP2 (-) and adjust VR3 to get a reading of 2.490V. VR4 is adjusted while monitoring the voltage between test point pins TP3 (+) and TPG (-) with your DMM, again to get a reading of 2.490V.

These adjustments effectively set the lowest current level ($20\mu\text{A}$) for $+I_{BIAS}$ and $-I_{BIAS}$.

The next four set-up adjustments set the higher current settings for $+I_{BIAS}$ and $-I_{BIAS}$, using VR5, VR6, VR7 and VR8. To do these adjustments, you need to fit two short lengths of hookup wire into two of the device lead positions on the ZIF socket, and then set up the *SemTest* for four different device tests. Here's the procedure:

- Take two short lengths of insulated wire with about 15mm of insulation at each end stripped off. Then, with the ZIF socket's actuator lever upright, introduce one end of each wire into the socket's 'B' and 'E' lead holes for a BJT. (It doesn't matter which of the two 'E' holes you use).
- Push the socket's actuator lever down into the horizontal position, to lock these temporary base and emitter leads in place.
- Switch your DMM to read low DC current levels (say $200\mu\text{A}$ to begin) and connect its test leads to the two wire leads: the '+' lead to the base wire and the '-' lead to the emitter wire.

Now we need to negotiate *SemTest*'s menu system to reach a device test set-up which will allow us to measure the various I_{BIAS} levels using the DMM. Apply power and press the MENU SELECT button for half a second or so. You should then see the opening device selection display:

Device to Test:▲

1:Diode/Zener▼

In case you're wondering, those '^' and 'v' symbols at the right-hand ends of the lines are meant to remind you that you can scroll up or down through a sequence of menu choices, using the UP or DOWN buttons.

For the first of these I_{BIAS} adjustments, we actually want to select some BJT (NPN) tests; so press either of these buttons briefly a number of times, until you see this display:

Device to Test:▲ 3:NPN bipolar▼

Since that's the type of device we want to set up for (even though there is no actual device plugged into the ZIF socket), confirm this by pressing the ENTER button. This will cause the display to change into:

Test parameter:▲ BVcbo (e o/c)▼

As before, note the symbols at far right on the display, indicating as before that other tests can be selected using the UP and DOWN buttons. So press either

of these buttons briefly a few times until you see this display:

Test parameter:▲ hFE (Ib=20µA)▼

This is the first test we want to set up for in order to make these set-up adjustments, so press the ENTER button to confirm it. The display will then become:

NPN bipolar: hFE(Ib20µA)=0000

Now, after checking that you have set voltage selector switch S2 to its 50V position, press the TEST ON/OFF button to turn on the DC-DC converter and take a measurement. LED1 should be on, to indicate that the DC-DC converter is operating and providing a test voltage. The LCD display will also change, but don't take much notice of the h_{FE} reading because there is no transistor connected at present (it will probably show an h_{FE} reading of either '00' or '01').

Your DMM should now show a figure very close to $20.0\mu\text{A}$ (the default/lowest I_{BIAS} level).

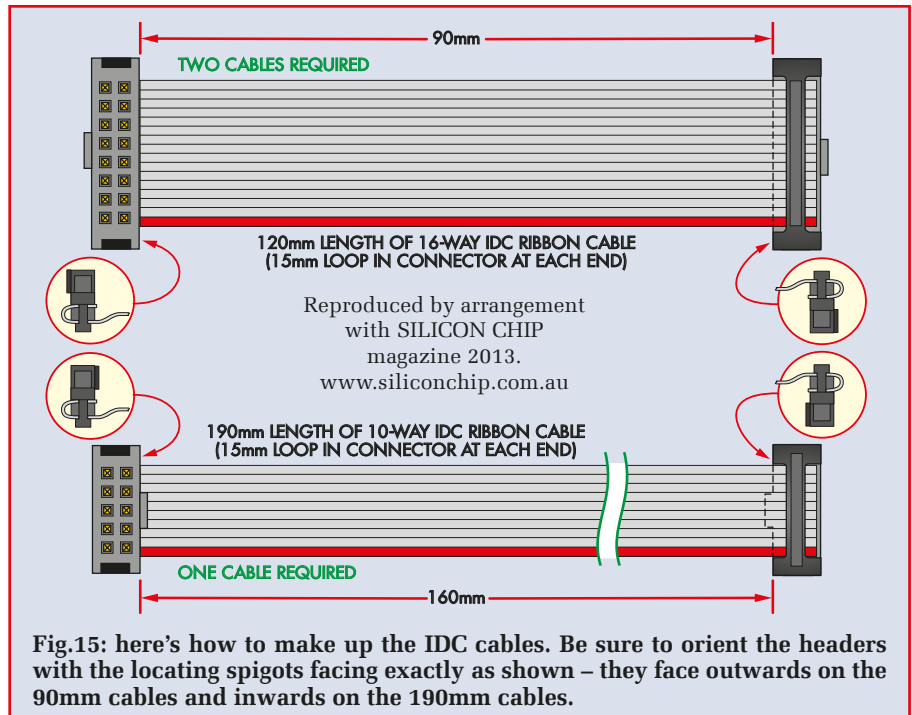

Fig.15: here's how to make up the IDC cables. Be sure to orient the headers with the locating spigots facing exactly as shown – they face outwards on the 90mm cables and inwards on the 190mm cables.

WARNING: SHOCK HAZARD!

THIS IS NOT A PROJECT FOR BEGINNERS! The DC-DC step-up converter used in this project can generate high voltages (up to 600V DC) and can also supply significant current. As a result, it's capable of delivering a nasty electric shock and there are some situations where such a shock could be potentially lethal.

For this reason, DO NOT touch any part of the circuit while it is operating, particularly around transformer T1, diode D1 and the two $47\mu\text{F}$ 450V electrolytic capacitors on the main (lower) PCB. In addition, high voltages can also be applied to the display board (via CON6) during operation, so it's not safe to touch certain parts on this board either. Exercise caution if testing the unit with the lid opened and always allow time for the $47\mu\text{F}$ capacitors to discharge before working on the circuit.

Note also that high voltages (up to 600V DC) can be present on the component leads when testing for high-voltage breakdown. DO NOT touch any device leads while testing is in progress. Always end the test by pressing the Test On/Off button (red LED off) and check that there is no high-voltage warning on the LCD before removing the DUT (Device Under Test).

Sourcing the rotary switch

As mentioned in the article, the 3-pole 4-position rotary switch (S2) must have a 42mm-long control shaft, so that when the case is assembled, it passes through the clearance holes in the front panel with enough length left over to attach the control knob.

A Lorlin CK1051 switch is suitable, and this can be sourced from Element14 (Cat. 1123697). Note that the shafts on the switches usually available from kit suppliers will be too short for this project.

Now press the TEST ON/OFF button again, and hold it down for a second or so until LED1 goes out, indicating that the DC-DC converter has been turned off. The LCD display will also return to its 'Press MenuSelect' message, ready for another test. And when you press the MENU SELECT button, you'll find that the *SemTest* has 'remembered' that you were testing an NPN bipolar device and will offer the same device test again:

**Device to Test: ▲
3:NPN bipolar ▼**

Confirm this by pressing the ENTER button. Then use either the UP or DOWN buttons until you get this display:

**Test parameter: ▲
hFE (I_b=100µA) ▼**

Press the ENTER button to confirm and finally press the TEST ON/OFF button again to turn on the DC-DC converter and take a measurement. As before though, don't worry about the h_{FE} measurement on the LCD display – pay attention to what the DMM is showing, because this will be reading the actual bias current. This should be close to 100.0µA. Now adjust VR6 with a small screwdriver until it reads 100.0µA.

Once that's done, press and hold down the TEST ON/OFF button until LED1 goes off. Then press the MENU SELECT and ENTER buttons and then UP or DOWN to get:

**Test parameter: ▲
hFE (I_b=500µA) ▼**

Press ENTER to confirm, set your DMM to read over 500µA, then press the TEST ON/OFF button. Your DMM should now read close to 500µA. Adjust VR5 to get that exact figure. Press the TEST ON/OFF button once again until LED1 goes off.

That completes the two adjustments for the +I_{BIAS} current levels. Those for the -I_{BIAS} levels are next on the list. This time, we use the tests for a PNP bipolar device instead of an NPN one, and we need to reverse the connections to the DMM test leads.

Press MENU SELECT again and then press the UP button once, to get:

**Device to Test: ▲
4:PNP bipolar ▼**

Press ENTER to confirm and press either UP or DOWN to select the 'h_{FE} (I_B=20µA)' test. Press ENTER to confirm and then press TEST ON/OFF. Your DMM should show close to 20.0µA, confirming the default/lowest -I_{BIAS} level. Now press and hold down TEST ON/OFF to stop this test.

Now press MENU SELECT again and you'll find that the PNP bipolar tests are still being offered. Press ENTER to confirm and then the UP or DOWN buttons until you get:

**Test parameter: ▲
hFE (I_b=100µA) ▼**

Confirm this by pressing ENTER and follow by pressing TEST ON/OFF to start the test. Your DMM should now be reading close to 100.0µA. Adjust trimpot VR7 to bring the reading as close as possible to that figure, then press TEST ON/OFF to stop the test.

Set the DMM to read more than 500µA and then press MENU SELECT, ENTER and the UP or DOWN buttons until you have selected:

**Test parameter: ▲
hFE (I_b=500µA) ▼**

Press ENTER and TEST ON/OFF again and confirm that the DMM reads close to 500µA. Adjust VR8 to obtain that exact figure, then press TEST ON/OFF again and you have completed all the setting-up adjustments for the *SemTest's* I_{BIAS} current levels.

One more adjustment remains: using trimpot VR1 to set the DC-DC converter output voltage levels. To do this, check that switch S2 is set to 50V. Then press MENU SELECT and UP or DOWN until you get:

**Device to Test: ▲
7:SCR ▼**

Press ENTER to confirm and either UP or DOWN until you get:

**Test parameter: ▲
Vak on (OPV) ▼**

Now press ENTER and TEST ON/OFF. The second line of the LCD should now read something like this:

Vak(OPV) = 49.6V

Adjust VR1 (just above the centre of the main board) until the LCD reading changes to:

Vak(OPV) = 50.0V

Finally, press the TEST ON/OFF button once. This completes all the set-up adjustments.

Final assembly

The front panel assembly can now be lowered down onto the case. Make sure that the three ribbon cables are folded neatly into the space above the lower PCB and not caught between the edges of the case or lid.

Fasten the case together with four M4 screws into the corner holes, then fit the knobs to the rotary switch and the pot and the assembly is complete.

Testing the HV crowbar

It's now necessary to check that the HV crowbar circuit is working correctly. To do this, power up the unit, wait a few seconds and then press the Menu Select button. You will get a display like this:

**Device to Test: ▲
1:Diode/Zener ▼**

Press Enter and then the Up button. The display will then show:

**Test parameter: ▲
Irev(OPV) ▼**

Press Enter again. Set the Device Operating Voltage to 25V, using the right-hand knob. Then press the Test On/Off button to start the test.

Now carefully measure the voltage across the top and bottom A and K terminals in the diodes and LEDs section of the test socket. You should get a reading close to 25V. If it's much lower (say, 12V) then either the crowbar circuit has triggered prematurely or there is a fault in the DC/DC converter circuit. You will need to switch off, open up the unit and check the crowbar and converter circuits for faults, such as incorrectly oriented components.

If you get a much higher reading than 25V, there is a problem with the DC/DC converter section. Switch off and measure the voltage across the A and K terminals until it drops to a safe level. Then open the unit up and look for the source of the problem.

Assuming all is well, press the Test On/Off button to terminate the test. You can now do a high-voltage test. The procedure is similar to before, except you want to do an $I_{REV}(BV)$ test. So when you get to this stage:

Device to Test: ▲ 1: Diode/Zener ▼

press enter twice and start the test.

Carefully measure the voltage across the A and K terminals again. It should be several hundred volts and it will rise to close to 600V after a number of seconds. Now press the Test On/Off button again to terminate the test while monitoring the voltage between the A and K terminals. It should immediately fall to just a few volts when the test is terminated.

If it remains high and only decreases slowly, the crowbar has failed to operate and you will need to wait for the capacitors to discharge before opening the unit up and checking for faults.

If the crowbar is not working (eg, if it fails), a warning will be displayed on the LCD immediately after performing a high-voltage test. This indicates that there is still a high voltage present at the test socket. If you get this warning then you should open the unit up and repair the crowbar circuit.

Using the SemTest

The *SemTest* is used as follows:

- STEP 1:** place DUT in ZIF socket and switch on.
- STEP 2:** Press Menu Select.
- STEP 3:** Use Up/Down buttons to select device type and press Enter.
- STEP 4:** Use Up/Down buttons to select test and press Enter.
- STEP 5:** For OPV tests, use right-hand knob to select test voltage.
- STEP 6:** Press Test On/Off to start test (red LED on) and read result.
- STEP 7:** Press Test On/Off again to finish test (red LED out).
- STEP 8:** check red LED is out and there is no high voltage warning on the LCD before removing DUT.

Exercise caution when testing components for high-voltage breakdown. Up to 600V DC is present on the device leads during such tests, so be careful not to touch them!

The biggest problem in using the *SemTest* is knowing the various lead configurations of the devices it can test. To that end, we have prepared a



This view inside the completed prototype shows how it all goes together. The two PCB assemblies are mounted in their respective case halves on spacers and joined together via the three IDC header cables.

connections chart (see page 27) showing commonly used diodes, LEDs, BJTs, MOSFETs, SCRs and PUTs. It can be stuck on a wall or to the underside of the *SemTest* case for easy reference.

For less common devices, you'll need to look up the connections in a data book or by downloading a data sheet from the manufacturer's website.

Finally, here are a few tips to guide you when you're doing some of the more specific tests:

- When reading the forward voltage drop V_F of a diode or LED, or the voltage drop V_{AK} of an SCR when it's conducting, be aware that the accuracy of this measurement is not very high due to measuring circuit limitations. So if you need to make really accurate measurements of V_F or V_{AK} , you'll need to use an external DMM with its leads connected across the device's 'A' and 'K' leads. Remember that during the same tests, it's OK to increase the device operating voltage to a higher setting in order to see the voltage drop at higher current levels.
- When you want to measure the h_{FE} of a BJT, start on the setting with the lowest I_{BIAS} level (ie, $20\mu A$), because this is the setting with the highest h_{FE} range. Only swing down to one of the

higher I_{BIAS} settings if the h_{FE} reading you get is very low (ie, below 300).

This should only be necessary with medium-to-higher power devices, which often have their 'peak' h_{FE} at higher currents.

- When you want to measure the I_{DS} vs V_{GS} characteristic of a MOSFET to get an idea of its transconductance or ' g_m ', start by selecting the highest device operating voltage which will not exceed the device's V_{DS} ratings. That's because the V_{GS} bias voltage (adjusted via VR10) is derived from the actual device operating voltage, which inevitably tends to drop once the device begins to draw drain-source current (due to voltage drop in the current-limiting resistors).

If you don't set the switch for a reasonably high voltage to start with, you'll find that it won't be possible to provide much V_{GS} once the device starts to conduct.

Actually, although you need to set the operating voltage within the device ratings when you start this test, it's OK to increase the setting to 100V during the test itself, if you need to do so in order to achieve a higher V_{GS} .

This won't cause any problems if you only increase the voltage setting once the device is conducting. **EPE**

EPE PIC PROJECTS VOLUME 1 MINI CD-ROM

A plethora of 20 'hand-PICked' PIC Projects from selected past issues of *EPE* Together with the PIC programming software for each project plus bonus articles

The projects are:

PIC-Based Ultrasonic Tape Measure

You've got it taped if you PIC this ultrasonic distance measuring calculator

EPE Mind PICKler

Want seven ways to relax? Try our PIC-controlled mind machine!

PIC MIDI Sustain Pedal

Add sustain and glissando to your MIDI line-up with this inexpensive PIC-controlled effects unit

PIC-based MIDI Handbells

Ring out thy bells with merry tolling – plus a MIDI PIC-up, of course!

EPE Mood PICKer

Oh for a good night's sleep! Insomniacs rejoice – your wakeful nights could soon be over with this mini-micro under the pillow!

PIC Micro-Probe

A hardware tool to help debug your PIC software

PIC Video Cleaner

Improving video viewing on poorly maintained TVs and VCRs

PIC Graphics LCD Scope

A PIC and graphics LCD signal monitor for your workshop

PIC to Printer Interface

How to use dot-matrix printers as data loggers with PIC microcontrollers

PIC Polywhatsit

A novel compendium of musical effects to delight the creative musician

PIC Magick Musick

Conjure music from thin air at the mere untouching gesture of a fingertip

PIC Mini-Enigma

Share encrypted messages with your friends — true spymaster entertainment

PIC Virus Zapper

Can disease be cured electronically? Investigate this controversial subject for yourself

PIC Controlled Intruder Alarm

A sophisticated multi-zone intruder detection system that offers a variety of monitoring facilities

PIC Big-Digit Display

Control the giant ex-British Rail platform clock 7-segment digits that are now available on the surplus market

PIC Freezer Alarm

How to prevent your food from defrosting unexpectedly

PIC World Clock

Graphically displays world map, calendar, clock and global time-zone data

PICAXE Projects

A 3-part series using PICAXE devices – PIC microcontrollers that do not need specialist knowledge or programming equipment

PIC-based Tuning Fork and Metronome

Thrill everyone by at long last getting your instrument properly tuned!

Versatile PIC Flasher

An attractive display to enhance your Christmas decorations or your child's ceiling



**ONLY
£14.75**
INCLUDING
VAT and P&P

NOTE: The PDF files on this CD-ROM are suitable to use on any PC with a CD-ROM drive. They require Adobe Acrobat Reader – included on the CD-ROM

EPE PIC PROJECTS CD-ROM ORDER FORM

Please send me (quantity)

EPE PIC PROJECTS VOL 1 CD-ROM

Price £14.75 each – includes postage to anywhere in the world.

Name

Address

.....

.....

..... Post Code

I enclose cheque/P.O./bank draft to the value of £

please charge my Visa/Mastercard/Maestro £

Card No.

Card Security Code

(The last 3 digits on or just under the signature strip)

Valid From Expiry Date

Maestro Issue No.



SEND TO:

**Everyday Practical Electronics,
Wimborne Publishing Ltd.,
113 Lynwood Drive, Merley, Wimborne,
Dorset BH21 1UU.**

Tel: 01202 880299. Fax: 01202 843233.

Email: orders@epemag.wimborne.co.uk

Payments must be by card or in £ Sterling – cheque or bank draft drawn on a UK bank.

Normally posted within seven days of receipt of order. Send a copy of this form, or order by letter if you do not wish to cut your issue.

**Order on-line from
www.epemag.com
or by Phone, Fax, Email or Post.**

BECOME A PIC PROJECT BUILDER WITH THE HELP OF EPE!



www.mikroe.com

Every embedded developer knows at least one of these words:
mikroC, mikroBasic, mikroPascal, Visual TFT, Visual GLCD, EasyPIC,
EasyPIC PRO, EasyPIC Fusion, EasyMx PRO, EasyAVR, Easy8051,
mikromedia, click, MINI, mikroBUS, mikroProg, Libstock...

How about you?

Jump Start

By Mike and Richard Tooley

Design and build circuit projects dedicated to newcomers, or those following courses taught in schools and colleges.



WELCOME to *Jump Start* – our series of seasonal ‘design and build’ projects for newcomers. *Jump Start* is designed to provide you with a practical introduction to the design and realisation of a variety of simple, but useful, electronic circuits. The series has a seasonal flavour, and is based on simple, easy-build projects that will appeal to newcomers to electronics, as well as those following formal courses taught in schools and colleges.

Each part uses the popular and powerful ‘Circuit Wizard’ software package as a design, simulation and printed circuit board layout tool. For a full introduction to Circuit Wizard, readers should look at our previous *Teach-In series*, which is now available in book form from Wimborne Publishing (see *Direct Book Service* pages in this issue).

Each of our *Jump Start* circuits include the following features:

- **Under the hood** – provides a little gentle theory to support the general principle/theory behind the circuit involved

- **Design notes** – has a brief explanation of the circuit, how it works and reasons for the choice of components
- **Circuit Wizard** – used for circuit diagrams and other artwork. To maximise compatibility, we have provided two different versions of the Circuit Wizard files; one for the education version and one for the standard version (as supplied by *EPE*). In addition, some parts will have additional files for download (for example, templates for laser cutting)
- **Get real** – introduces you to some interesting and often quirky snippets of information that might just help you avoid some pitfalls
- **Take it further** – provides you with suggestions for building the circuit and manufacturing a prototype. As well as basic construction information, we will provide you with ideas for realising your design and making it into a complete project
- **Photo Gallery** – shows how we developed and built each of the projects.

In this month’s Jump Start and with Easter on the way, we shall be describing a simple Egg Timer that’s ideal for an Easter present and just right for cooking the perfect boiled egg for Easter breakfast!

Coming attractions

Issue	Topic	Notes
May 2012 ✓	Moisture alarm	
June 2012 ✓	Quiz machine	Get ready for a British summer!
July 2012 ✓	Battery voltage checker	Revision stop!
August 2012 ✓	Solar mobile phone charger	For all your portable gear
September 2012 ✓	Theft alarm	Away from home/school
October 2012 ✓	Wailing siren, flashing lights	Protect your property!
November 2012 ✓	Frost alarm	Halloween “spooky circuits”
December 2012 ✓	Mini Christmas lights	Beginning of winter
January 2013 ✓	iPod speaker	Christmas
February 2013 ✓	Logic probe	Portable Hi-Fi
March 2013 ✓	DC motor controller	Going digital!
April 2013 ✓	Egg Timer	Ideal for all model makers
May 2013	Signal injector	Boil the perfect egg!
June 2013	Simple radio	Where did that signal go?
July 2013	Temperature alarm	Ideal for camping and hiking
		It ain’t half hot ...

Under the hood

Our *Egg Timer* circuit uses a single integrated circuit chip, which was designed specifically for a wide range of timing applications. As we’ve already seen, the 555 timer IC is an extremely versatile device. Not only is it a neat mixture of analogue and digital circuitry, but also its applications are virtually limitless in the world of basic pulse generation. The standard 555 timer supplied in a standard 8-pin dual-in-line (DIL) package with the pinout details is shown in Fig.1.

The standard 555 timer operates from supply rail voltages of between 4.5V and 15V, and because this includes the normal range for TTL devices (5V ± 5%) this chip can be used in conjunction with conventional transistor-transistor logic (TTL) circuitry.

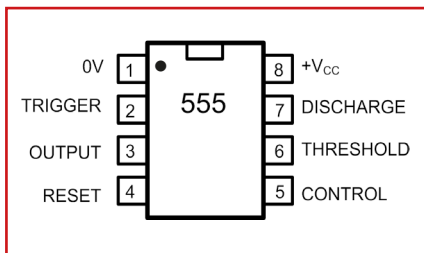

Fig.1. Pin connections for the standard 555 timer IC

Fig.2 shows a standard 555 timer operating as a monostable pulse generator. The term ‘monostable’ refers to the fact that the output has only one stable state, and it will always return to this state after a period of time spent in the opposite state. The monostable timing period (ie, the time for which the output is high) is initiated by a falling-edge trigger pulse applied to the trigger input (pin 2). When this falling-edge trigger pulse is received and falls below one third of the supply voltage, the output at pin 3 goes high.

The capacitor, C, then charges through the series resistor, R, until the voltage at the threshold input (pin 6) reaches two thirds of the supply voltage (Vcc). At this point, the output goes low. The device then remains in the inactive state until another falling trigger pulse is received.

The output waveform produced by the circuit of Fig.2 is shown in Fig.3. The waveform has the following properties:

Time for which output is high:
Recommended trigger pulse width:

$$t_{on} = 1.1CR$$

Where t_{on} and t_{tr} are in seconds, C is

$$t_{tr} < \frac{t_{on}}{4}$$

in farads and R is in ohms.

The period of the 555 monostable output can be changed very easily by simply altering the values of the timing resistor, R, and/or timing capacitor, C. Doubling the value of R will double the timing period. Similarly, doubling the value of C will double the timing period.

Design notes

Having briefly introduced the mathematics, let’s use it to calculate the range of values of C and R that we might need in our egg timer. Boiling an egg is not always as easy as it sounds and producing a perfect egg is all down to the timing. Most people like to have their eggs boiled for somewhere between 3.5 and 4.5 minutes. This produces an egg that has the white set

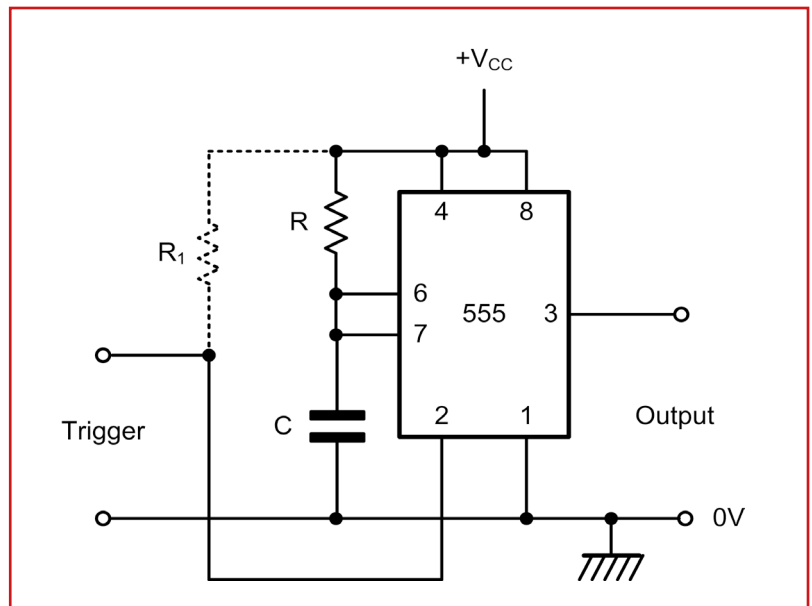

Fig.2. The 555 timer IC in monostable configuration

on the inside of the shell, but preserves a runny yolk in the centre. Other people prefer their eggs to be either ‘soft boiled’ or ‘hard boiled’.

A ‘soft boiled’ egg is produced in about three minutes, while a ‘hard boiled’ egg requires eight minutes, or more. These times also depend on the size of the egg: large eggs require a longer time than small eggs. All of this suggests that we might need our egg timer to work over a range that extends from as little as one minute (for those that like their eggs extremely soft.) to as much as 10 minutes (for those that prefer their eggs really hard-boiled.)

Let’s start by considering the component values that we will need in our timer in order to produce the minimum and maximum time periods. We will start by taking

another look at the equation that we met earlier:

$$t_{on} = 1.1CR$$

To vary the ‘on’ time (ie, the period for which the output goes high) we could vary the value of capacitance, resistance or both. Variable capacitors are only available with very small values and they can be very expensive, so varying C isn’t really an option. Instead, we will select an appropriate value of capacitance and use a variable resistor (potentiometer) to change the value of resistance.

Because we are dealing with quite long periods of time (at least in the context of electronics.) it’s probably best to start with quite a large value of capacitance, so let’s choose 470µF and see how things work out.

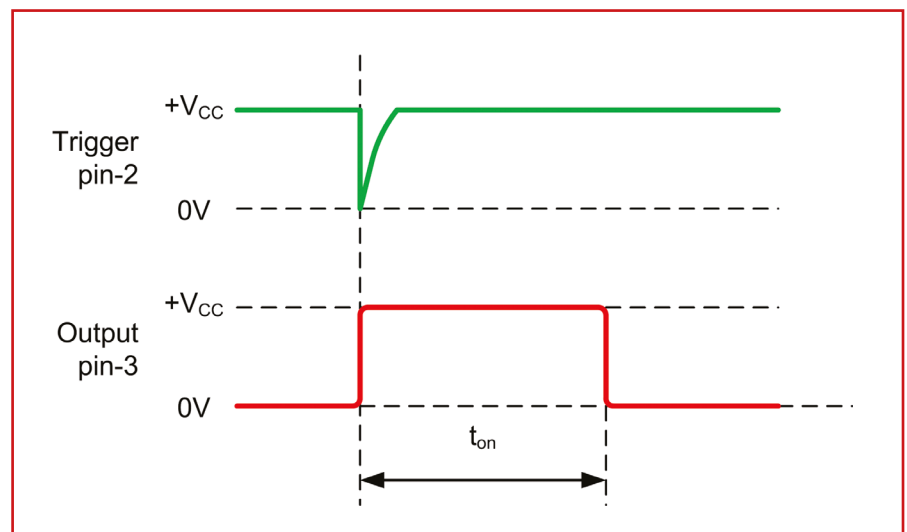

Fig.3. Waveforms for monostable operation

Making R the subject of our equation gives:

$$R = \frac{t_{on}}{1.1C}$$

and since we have chosen a value of 470µF for C:

$$R = \frac{t_{on}}{1.1 \times 470 \times 10^{-6}} = \frac{t_{on}}{517 \times 10^{-6}} =$$

$$1.934 \times t_{on} \times 10^{-3} = 1.934 \times t_{on} \text{ k}\Omega$$

To obtain a time period of one minute we make $t_{on} = 60$ seconds, so:

$$R = 1.934 \times 60 = 116\text{k}\Omega$$

Rounding this down to the nearest preferred value gives us a value of 100kΩ.

To obtain a time period of 10 minutes we make $t_{on} = 600$ seconds, so:

$$R = 1.934 \times 600 = 1.16\text{M}\Omega$$

Rounding this down to the nearest convenient value gives us a value of 1.1MΩ, which can conveniently be made by connecting a 100kΩ fixed resistor (the value that we require for the minimum time period) in series with a variable potentiometer (resistor) of 1MΩ. This arrangement should give us an adjustable time period ranging from just less than a minute to a little less than 10 minutes.

If you do the maths, the actual range of values are from 51.7 seconds to 9.5 minutes with a mid-position of 4.3 minutes (the perfect time for an egg with a soft yolk, but firm white). It's also worth noting that the usual range of values for capacitance and resistance in a 555 monostable timer are 470pF to 470µF and 1kΩ to 3.3MΩ respectively. Outside this range operation can be somewhat unpredictable!

Finally, here's another interesting fact. Due to the reduced air pressure, water boils at a lower temperature at high altitudes and this makes cooking a boiled egg progressively more difficult as the height increases above sea level. If you happen to live at the top of a 1,500m mountain, you will need to roughly double the time it takes to prepare your perfect egg. And, at over 2,750m it's best to stick to scrambled eggs or omelettes simply because the water in your pan will boil and turn into steam long before your egg has been nicely cooked!

Get real

The complete circuit of the *Egg Timer* is shown in Fig.4. In order to initiate a timing cycle when the circuit is first switched 'on', C1 momentarily holds the potential at the trigger input (pin

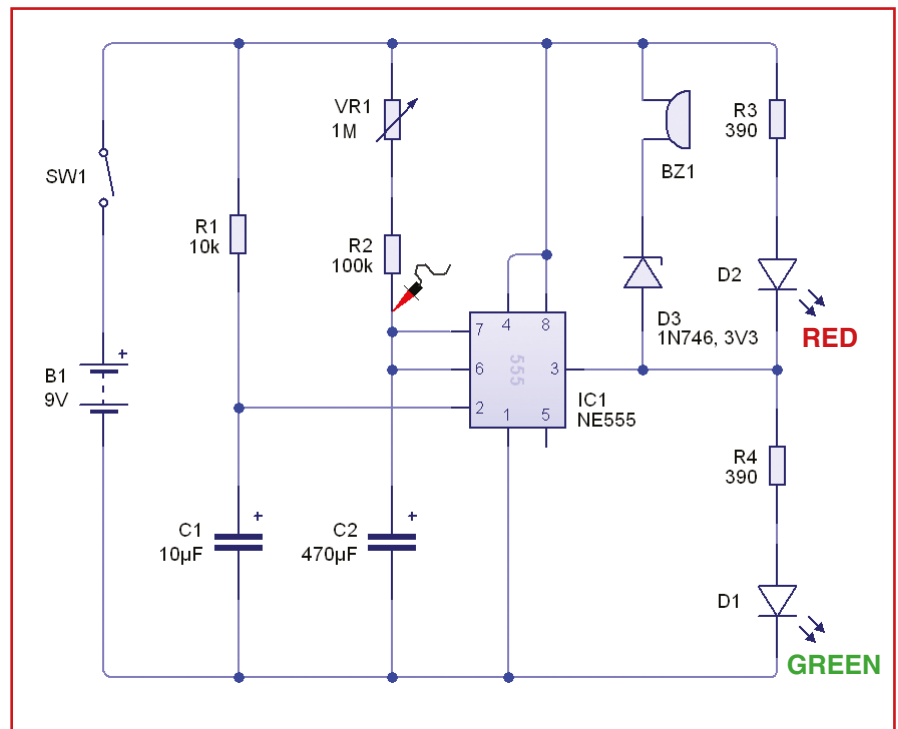

Fig.4. Complete circuit of the egg timer

2) low before rapidly charging through resistor R1. The monostable timing period is determined by VR1, R2 and C2 (see Design notes).

The output of the 555 timer from pin 3 is taken to a buzzer (BZ1), which sounds when the output voltage falls at the end of the monostable timing period. Red and green LEDs

(light emitting diodes) (D2 and D1 respectively) are used to indicate the output state. D1 is illuminated during the timing period and D2 becomes illuminated at the end of the period (at the same time as the buzzer sounds). This ensures that the egg timer produces a visual output as well as an audible output.

Egg Timer - using Circuit Wizard

NOW we've looked at the theory behind the *Egg Timer* circuit, let's see it in operation. Enter the circuit using Circuit Wizard by dragging the appropriate components from the gallery on the right and connecting them up appropriately. Your finished circuit should be similar to that shown in Fig.4.

Don't forget to set the values of the components (either by right-clicking and selecting 'Properties' or double clicking). Once you have finished, simulate the circuit and check its operation. You may wish to turn the variable resistor (VR1) down to a minimum (see Fig.5) as you might become impatient waiting for the alarm to go off after setting the longest time.

As we discussed in the theory section, the circuit relies on the 555's trigger input momentarily being held high. Circuit Wizard 'misses' this if you close switch SW1 when the simulation has already started. Therefore, you should close SW1 *before* pressing

the play button to start the simulation and it should work nicely.

Next, it's worth experimenting with the different views to help you visualise the currents/voltages in the circuit, and gain an understanding of its operation. Placing a probe on pin 6/7 of the 555 (Fig.6) allows you to see a graph of the voltage building as the capacitor charges (Fig.7).

Try experimenting with the value of VR1 – for example setting this to your calculated value for a soft boiled egg and time the period of delay. Can you

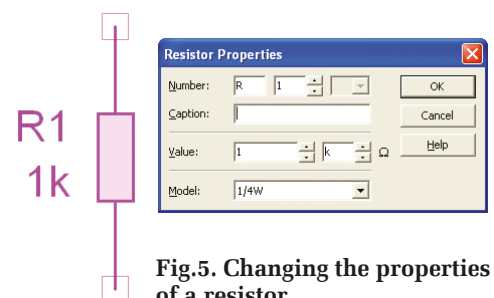

Fig.5. Changing the properties of a resistor

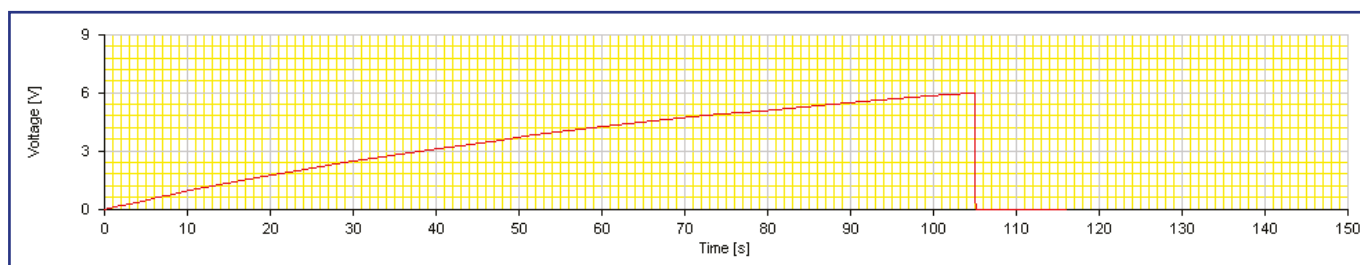

Fig.7. Graph showing how the capacitor voltage changes with time

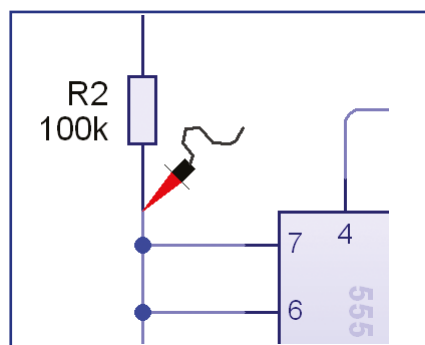

Fig.6. Placing a probe in the circuit get it to three minutes (180 seconds) exactly?

Once you are happy with the operation of the circuit you are ready to proceed to creating your own PCB design. To start this process, click 'Convert to PCB Layout' from the toolbar (Fig.8).

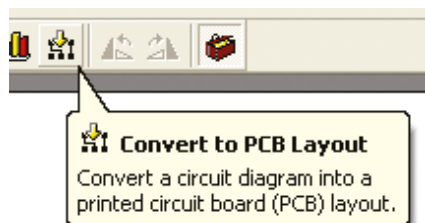

Fig.8. Starting the 'convert to printed circuit' wizard

As we discussed earlier in this series, Circuit Wizard's automatic routing is a little limited and does struggle to successfully convert all but the most simple circuits, although with a little help from us we can get some much better results from the software. In our experience, it is best not to let Circuit Wizard route the tracks straight away. Instead, select 'Rats Nest; No Placement or Routing' in the 'convert to printed circuit' wizard (Fig.9) and then arrange the components so that the nets (the green lines that show what connections must be made) are as neat as possible with as few crossed lines as possible.

You may also wish to put certain components in a desirable position; for example power connections at the edge of a PCB. Once you are happy with the positions of the components then instruct Circuit Wizard to autoroute (PCB Layout Tools – Routing Options

– Route All Nets...). Having made its job that much easier you should see a better track layout (see Fig.10 and Fig.11).

Of course, you can still add the tracks yourself in accordance with the net lines if you prefer. For more help with the PCB conversions please refer to *Teach-In 2011* where we explained the process in greater detail.

Fig.12 shows our example PCB layout for the *Egg Timer* circuit. A copy of the artwork and *Circuit Wizard* file for this design is available on our website at www.tooley.co.uk/epe. Fig.13 shows our example PCB design being simulated with off-board components (PP3 battery and

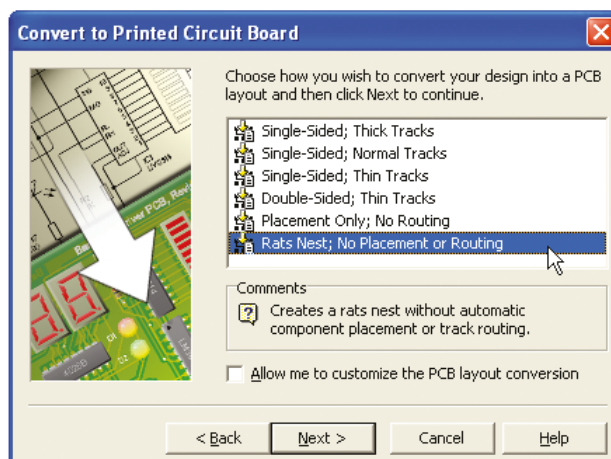

Fig.9. Selecting *Circuit Wizard's* auto routing options

SPST switch). Note that, as with simulating the circuit board, in order

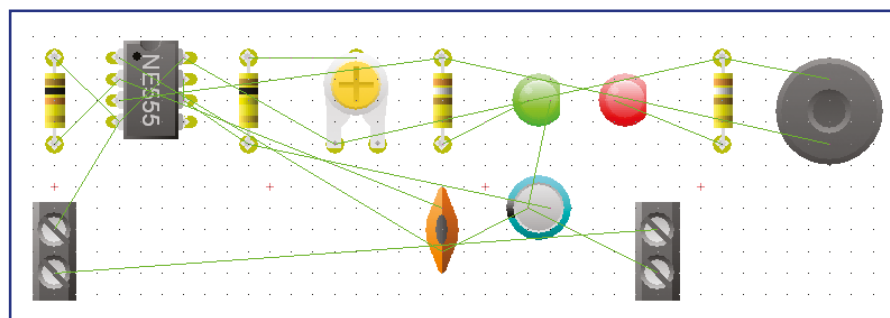
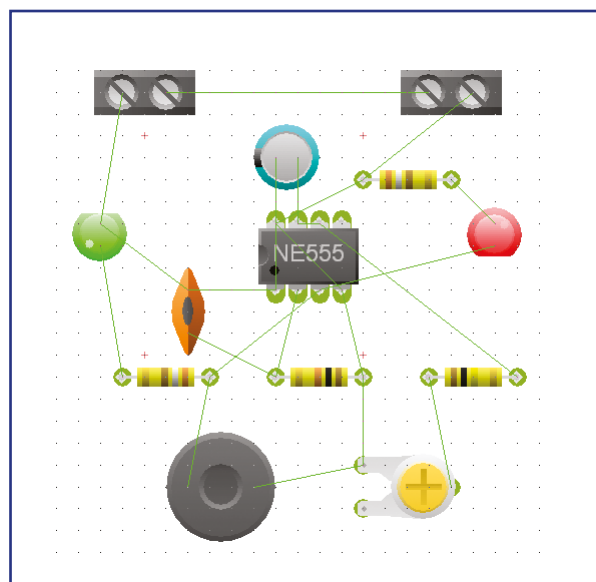

Fig.10 (above). 'Rats nest' with no routing

Fig.11 (right). Components arranged before autorouting



For more info:
www.tooley.co.uk/epe

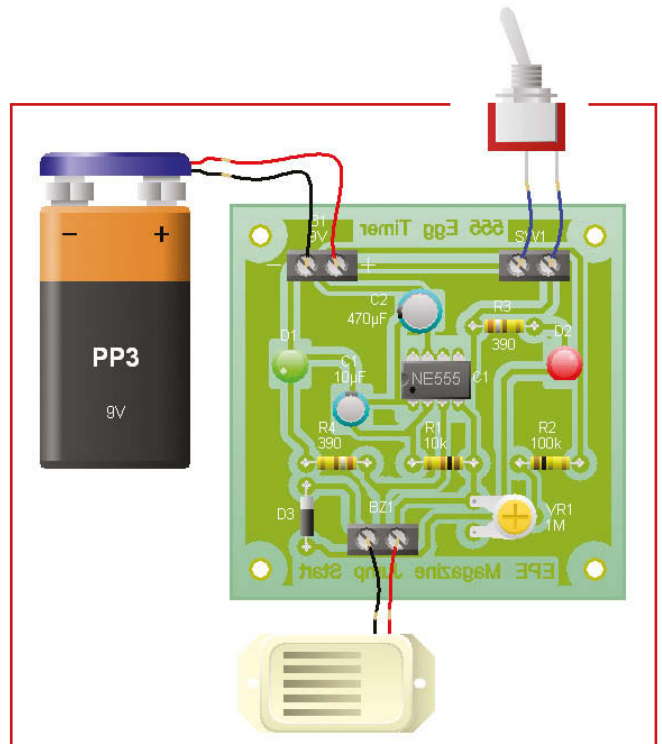
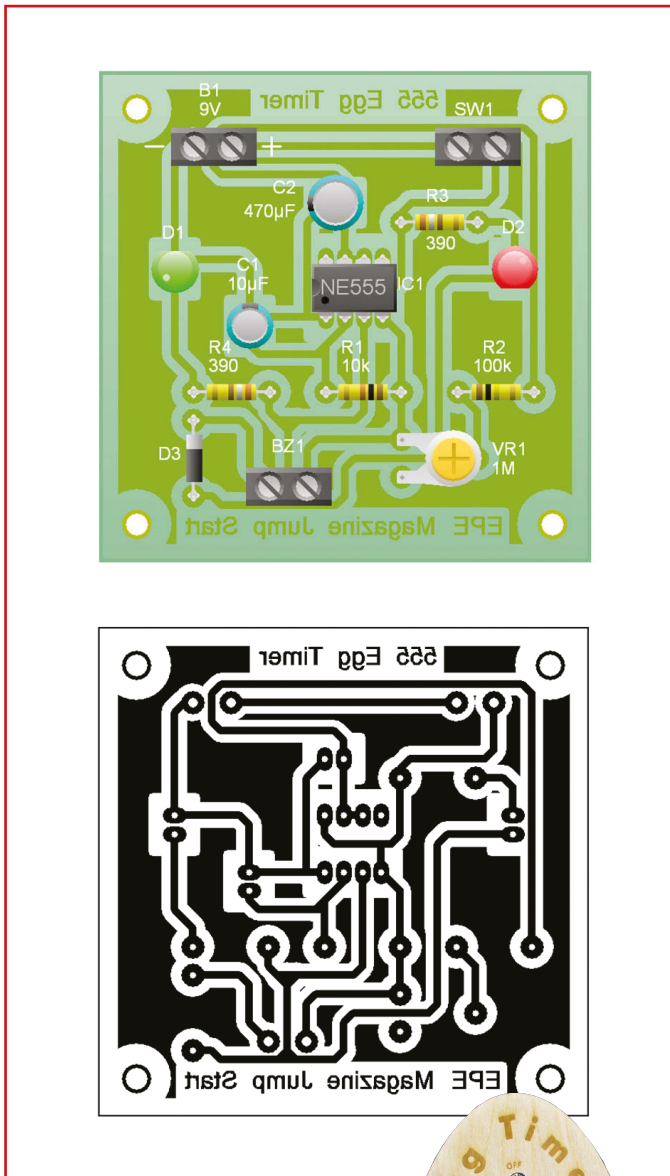

Fig.13. Example PCB being simulated with off-board components

for the circuit to ‘start’ you should close SW1 before starting the simulation.

The Photo Gallery shows our example PCB as a working product. Almost any low-cost 3V-to-9V DC sounder/ electronic ‘buzzer’ can be used with the circuit and should provide ample volume, even in a noisy environment. A simple egg-shaped stand was designed using a CAD package and cut from 3mm ply on a laser cutter. The dimensions of the PCB and mounting points were easily acquired by exporting the PCB design from *Circuit Wizard* (File – CAD/CAM – Export DXF...) and importing it into CAD software.

All of these additional design files are available on our website. The Photo Gallery also shows the various stages in developing and manufacturing our prototype *Egg Timer*.

Fig.12 (left). PCB design example (from top to bottom) ‘Real World’ component layout and ‘Artwork’ viewed through the board. Final size is 66mm × 66mm

You will need...

Egg Timer

- 1 PCB, code 896, available from the *EPE PCB Service*, size 66mm × 66mm
- 3 Two-way PCB mounting terminal blocks
- 1 battery clip for a PP3 battery
- 1 9V (PP3) battery
- 1 8-pin low-profile DIL socket
- 1 miniature buzzer, BZ1 (see text)
- 1 SPDT miniature toggle switch (SW1)
- 4 PCB mounting pillars

Semiconductors

- 1 555 timer (IC1)
- 1 Green LED (D1)

- 1 Red LED (D2)
- 1 3.3V Zener diode (D3)

Resistors

- 1 10kΩ (R1)
- 1 100kΩ (R2)
- 2 390Ω (R3 and R4)
- VR1 1MΩ miniature skeleton preset

Capacitors

- 1 10μF 50V radial electrolytic (C1)
- 1 470μF 25V radial electrolytic (C2)

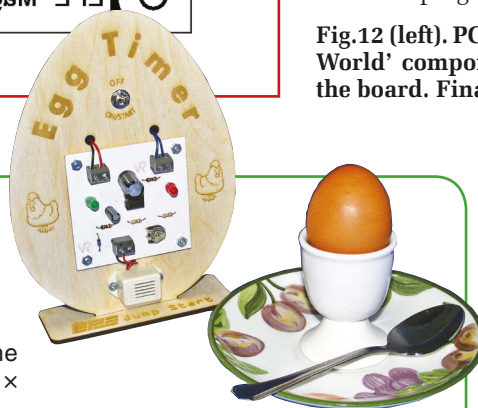

A note regarding Circuit Wizard versions:

Circuit Wizard is available in several variants; Standard, Professional and Education (available to educational institutions only). Please note that the component library, virtual instruments and features available do differ for each variant, as do the licensing limitations. Therefore, you should check which is relevant to you before purchase. During the Jump Start series we aim to use circuits/features of the software that are compatible with the latest versions of all variants of the software. However, we cannot guarantee that all items will be operational with every variant/version.

Photo gallery...

The Gallery is intended to show readers some of the techniques that they can put to use in the practical realisation of a design, such as PCB fabrication and laser cutting. This is very important in an educational context, where students are required to realise their own designs, ending up with a

finished project that demonstrates their competence, skills and understanding. The techniques that we have used are available in nearly every secondary school and college in the country, and we believe that our series will provide teachers with a tremendously useful resource!



Stand design and manufacture

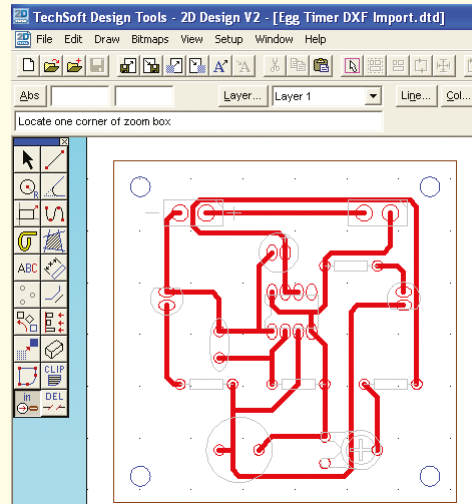

Importing the *Circuit Wizard* PCB design into a CAD package prior to manufacture

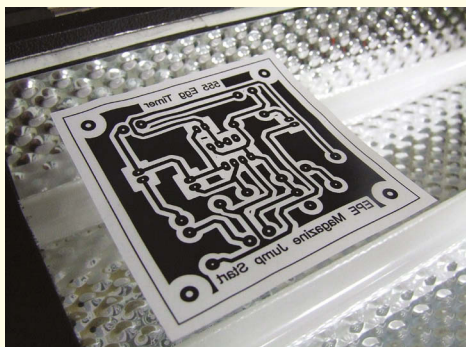

Printed circuit transparency prior to etching

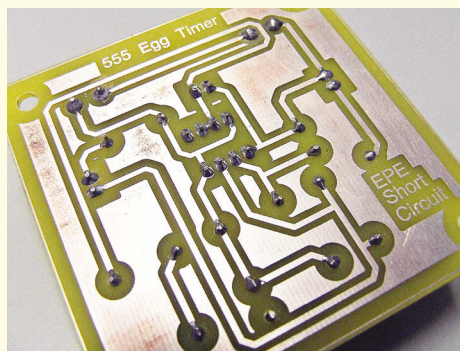

Rear of the assembled printed circuit showing neatly soldered joints

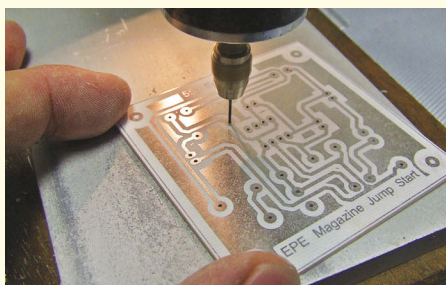

Drilling the printed circuit board

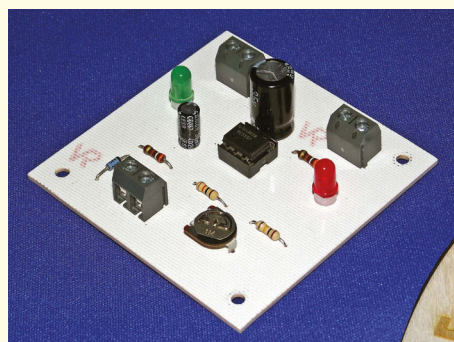

Completed printed circuit with components

Next month

In next month's *Jump Start*, we will describe the design and construction of a *Signal Injector* that is ideal for circuit fault finding. See you next month!

Front view of the completed *Egg Timer*



Special thanks to Chichester College for the use of their facilities when preparing the featured circuits.

EPE EVERYDAY PRACTICAL ELECTRONICS

EPE Magazine
can now be downloaded at
PocketMags.com
or download the app for
your iPad, iPhone, iPod
Touch or Android phone



The No 1 UK magazine for Electronics Technology & Computer projects is now available to download worldwide

- Each individual issue costs only £1.99
- 6 Month Subscription £9.99
- 12 Month Subscription £19.99
(just £1.67 an issue)



Download Now
and have *EPE* at your
fingertips



Max's Cool Beans

By Max The Magnificent

A bright future

Field Programmable Gate Arrays (FPGAs) aren't new, but these days they are evolving in surprising ways.

In the not-so-distant past, integrated circuits had fixed functions. For example, the 7400-series TTL devices each contain a handful of logic gates or register elements, and designers used to connect a lot of these components together to implement their systems.

Another type of component is a semiconductor memory device. And we also have microprocessors (μ Ps) and microcontrollers (μ Cs). This latter case is interesting because we can change what they do by modifying the programs they are running, but the underlying device itself is essentially nothing more than a complex state machine whose functionality is 'frozen in silicon.'

In 1984, a company called Xilinx announced a new class of component, which they dubbed the FPGA (the first FPGAs didn't actually become available until 1985). The idea was to have a device whose function can be configured 'on-the-fly' when its PCB is powered-up.

The way I like to think about this is that the FPGA contains little 'islands' of programmable logic blocks in a 'sea' of programmable interconnects. Each programmable logic block contains a small amount of logic, including a lookup table (LUT), multiplexer, register (flip-flop), and so forth. The ways in which these logical elements function are determined by special 'configuration cells.'

For the purposes of this column, we will consider SRAM-based FPGAs in which the configuration elements are implemented as SRAM cells. Using these configuration cells, we can specify the contents of the lookup table (which can be used to represent almost any combination of simple logical functions), the operation of the register (should it act as a flip-flop or a latch, is the clock positive-edge or negative-edge triggered), and so forth.

Configuration cells are also used to determine how the outputs from one logic block are connected to the inputs of another. Also how the primary inputs and outputs to the device are connected to other logic blocks.

In comparison

The first FPGAs were incredibly simple by today's standards. They contained an array of $8 \times 8 = 64$ logic blocks, each containing only a 4-input lookup table, a multiplexer, and a register. These devices could be used to gather 'glue logic' functions together and to implement simple state machines and control logic. By comparison, today's high-end FPGAs can contain hundreds of thousands of logic blocks, with 6-input, 7-input, or even 8-input lookup tables. This programmable fabric can be used to implement any logical function, including one or more soft microprocessor cores, if required.

In addition to the fundamental programmable fabric, today's high-end FPGAs can contain blocks of SRAM, clock generators, phase-locked loops (PLLs), peripheral functions, and so forth. Some even contain hard-core microcontrollers. Consider the Zynq-7000 All Programmable SoC (System-on-Chip) from Xilinx. It combines a full hard-core implementation of a dual ARM Cortex-A9 microcontroller subsystem (running at up to 1GHz and including

floating-point engines, on-chip cache, counters, timers, etc.), coupled with a wide range of hard-core interface functions (SPI, I²C, CAN, etc.), and a hard-core dynamic memory controller, all augmented with a large quantity of traditional programmable fabric, some programmable analogue functions, and a substantial number of general-purpose input/output (GPIO) pins.

How much would you expect to pay for one of these beasts? Well, at the moment only the higher-end members of the family are available, but Xilinx say that in the not-to-distant future, smaller members of the family will cost around \$15.

Learning curve

Let's return to simple FPGAs that contain only fundamental programmable fabric and blocks of SRAM. One reason these FPGAs are of interest is

that they can perform massive amounts of operations in parallel, which means they can dramatically outperform traditional processors when it comes to things like digital signal processing. One of my friends is a microcontroller expert who builds robots as a hobby – he's augmenting his microcontrollers with FPGAs.

But how do you set about learning something like this? Well, my friend Jack Gassett, founder of the Gadget Factory, has created a low-cost FPGA development platform called Papilio. Of particular interest is the fact that the FPGA on this board can be configured to look like an Arduino processor, on which you can run your existing Arduino programs (<http://bit.ly/Ly45Xg> and <http://bit.ly/UP-GpRo> to see some special Papilio offers). Another friend, Mike Field has written a free book on VHDL (one of the languages used to capture FPGA designs) that is targeted at the Papilio (<http://bit.ly/ReDcFt> to learn more).

The bottom line is that, although it's certainly tremendously useful to learn things like C/C++ programming and microcontrollers, it's also going to become increasingly valuable to know things like VHDL and FPGAs.

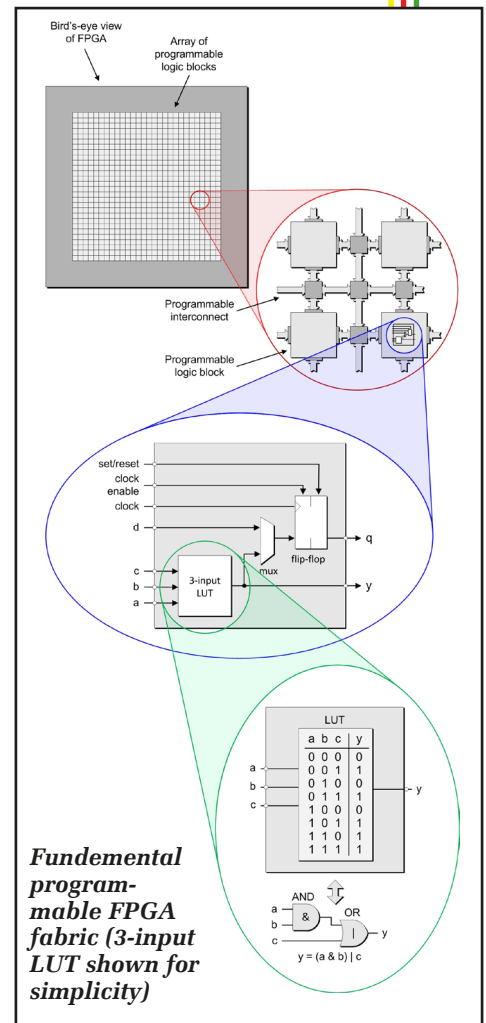

We can supply back issues of *EPE* by post, most issues from the past five years are available. An *EPE* index for the last five years is also available at www.epemag.com. Where we are unable to provide a back issue a photocopy of any one article (or one part of a series) can be purchased for the same price. Issues from Jan. 99 are available on CD-ROM or DVD-ROM – and back issues from recent years are also available to download from www.epemag.com. Please make sure all components are still available before commencing any project from a back-dated issue.

DID YOU MISS THESE?



BACK ISSUES ONLY £5.00 (each inc. UK p&p.)

Overseas prices £5.80 each surface mail, £6.80 each airmail.

We can also supply issues from years: 2006 (except Jan., Feb., Mar., Apr., May, July), 2007 (except June, July, Aug), 2008 (except Aug, Nov, Dec), 2009 (except Jan, Mar, Apr), 2010 (except May, June, July, August, Oct, Nov, Dec) 2011 (except Jan).

Where we do not have an issue a photocopy of any **one article** or **one part** of a series can be provided at the same price.

FEB '12

PROJECTS • Air Quality Monitor • GPS Car Computer – Part 2 • WIB – WebServer In A Box – Part 3 plus Add-on • Programming PICs: How It's Done • Ingenuity Unlimited
FEATURES • Recycle It! • Techno Talk • Interface • Circuit Surgery • PIC N' Mix • Net Work.

MAR '12

PROJECTS • High-Quality Digital Audio Signal Generator – Part 1 • Accurate Thermometer/Thermostat • Internet Time Display Module (WIB) • Solar-Powered Intruder Alarm • Ingenuity Unlimited
FEATURES • Techno Talk • Practically Speaking • Max's Cool Beans • PIC N' Mix • Net Work.

APR '12

PROJECTS • EHT Stick • High-Quality Digital Audio Signal Generator – Part 2 • Capacitor Leakage Adaptor For DMMs • WIB FAQs
FEATURES • Techno Talk • Circuit Surgery • Interface • Max's Cool Beans • PIC N' Mix • Net Work.

MAY '12

PROJECTS • Compact High-Performance 12V Stereo Amplifier • High-Quality Digital Audio Signal Generator – Part 3 • Low-Power Car/Bike USB Charger • Solar-Powered Lighting Controller – Part 1
FEATURES • Techno Talk • Jump Start – Moisture Detector • Circuit Surgery • Practically Speaking • PIC N' Mix • Net Work.

JUNE '12

PROJECTS • Digital Insulation Meter • Dual Tracking ±0V To 19V Power Supply – Part 1 • Low-Power Car/Bike USB Charger • Solar-Powered Lighting Controller – Part 2
FEATURES • Jump Start – Quiz Machine • Techno Talk • Pico 2205 MSO PC oscilloscope • PIC N' Mix • Circuit Surgery • Interface • Net Work.

JULY '12

PROJECTS • Lab-Standard 16-Bit Digital Potentiometer • Intelligent 12V Fan Controller • Dual Tracking ±0V To 19V Power Supply – Part 2
FEATURES • Jump Start – Battery Voltage Checker • Techno Talk • PIC N' Mix • Circuit Surgery • Practically Speaking • Max's Cool Beans • Net Work.

AUG '12

PROJECTS • Ultrasonic Cleaner • Electrolytic Capacitor Reformer and Tester – Part 1 • High-Performance Microphone Preamp • High-Power Reversible DC Motor Speed Controller
FEATURES • Jump Start – Solar-Powered Charger • Raspberry Pi Review • Techno Talk • PIC N' Mix • Circuit Surgery • Interface • Net Work.

SEPT '12

PROJECTS • Designing And Installing A Hearing Loop For The Deaf • Hearing Loop Receiver • Ultrasonic Anti-Fouling For Boats – Part 1 • Electrolytic Capacitor Reformer and Tester – Part 2
FEATURES • Jump Start – Versatile Theft Alarm • Raspberry Pi – Real-Time Clock • PIC N' Mix • Circuit Surgery • Practically Speaking • Net Work.

OCT '12

PROJECTS • Two TOSLINK-S/PDIF Audio Converters • Digital Lighting Controller – Part 1 • Ultrasonic Anti-Fouling For Boats – Part 2 • Designing And Installing A Hearing Loop For The Deaf – Part 2 • Ingenuity Unlimited
FEATURES • Jump Start – Spooky Circuits • Techno Talk • Interface • Circuit Surgery • Max's Cool Beans • Net Work.

NOV '12

PROJECTS • Hearing Loop Level Meter – Part 1 • Digital Lighting Controller – Part 2 • RFID Security System • Easy USB *plus* Telescope Driver Control • Ingenuity Unlimited
FEATURES • Jump Start – Frost Alarm • Techno Talk • Review – Picoscope 3406B • Practically Speaking • Circuit Surgery • Max's Cool Beans • Net Work.

DEC '12

PROJECTS • Universal USB Data Logger – Part 1 • Hot-Wire Cutter • Digital Lighting Controller – Part

3 • Hearing Loop Level Meter – Part 2 • Ingenuity Unlimited
FEATURES • Jump Start – Mini Christmas Lights • Techno Talk • PIC N' Mix • Circuit Surgery • Interface • Max's Cool Beans • Net Work.

JAN '13

PROJECTS • 3-Input Stereo Audio Switcher • Stereo Compressor • Low Capacitance Adaptor For DMMs • Universal USB Data Logger – Part 2 • **FEATURES** • Jump Start – iPod Speaker • Techno Talk • PIC N' Mix • Raspberry Pi – Keypad and LCD Interface • Circuit Surgery • Practically Speaking • Max's Cool Beans • Net Work.

FEB '13

PROJECTS • Semtest – Part 1 • Crystal DAC • 10W LED Floodlight • Built-In Speakers • Universal USB Data Logger – Part 3
FEATURES • Jump Start – Logic Probe • Techno Talk • PIC N' Mix • Raspberry Pi – Software Investigation • Circuit Surgery • Interface • Max's Cool Beans • Net Work.

MAR '13

PROJECTS • Lightning Detector • SemTest – Part 2 • Digital Spirit Level • Interplanetary Voice • Ingenuity Unlimited
FEATURES • Jump Start – DC Motor Controller • Techno Talk • PIC N' Mix • Raspberry Pi – Further Investigation • Circuit Surgery • Practically Speaking • Max's Cool Beans • Net Work.

ORDER FORM – BACK ISSUES – PHOTOCOPIES – INDEXES

Send back issues dated.....

Send photocopies of (article title and issue date).....

Name

Address.....

..... Tel:

I enclose cheque/P.O./bank draft to the value of £.....

Please charge my Visa/Mastercard/Maestro £.....

Card No Maestro Issue No

Valid From Card Expiry Date Card Security Code

(The last 3 digits on or just under the signature strip)

SEND TO: **Everyday Practical Electronics, Wimborne Publishing Ltd., 113 Lynwood Drive, Merley, Wimborne, Dorset BH21 1UU.**
Tel: 01202 880299. Fax: 01202 843233.
E-mail: orders@epemag.wimborne.co.uk On-line Shop: www.epemag.com

Payments must be in £ sterling – cheque or bank draft drawn on a UK bank. Normally posted within seven days of receipt of order. Send a copy of this form, or order by letter if you do not wish to cut your issue.



M04/13

PIC n' Mix

Mike Hibbett

Our periodic column for PIC programming enlightenment

Time ticks by

LAST month, we added 50p-worth of electronics to our PIC processor circuit and gained an ultra-low-power real-time clock. A nice achievement in itself, but while the one second ticks live only inside the processor, it's not very useful.

So this month, we look at making it a little more useful. And find a few problems with last month's design along the way. That's how it goes when designing embedded systems – two steps forward, one step back!

More on oscillators

First, let's talk a little more about the processor clock modes, starting with different oscillator types and why we need such a wide selection. An oscillator is the source of our clock, providing the alternating on/off signal that generates the heartbeat of the processor.

Clocks have a number of different uses: providing the basic sequencing of the instruction decoding and execution, giving an accurate deterministic time reference and sequencing all the on-chip peripherals. Serial interfaces, analogue-to-digital conversion, USB – they all require a consistent clock to perform their functions. However, not necessarily all at the same frequency or the same accuracy. Those last points are significant, and we will explain how we can take advantage of them, and why, later in the article.

Fig.1 shows the different sources of clock signals that can be used by many PIC processors, with all of them being applicable to our current choice, the PIC18F27J13. Although we show a single source per example it is possible to combine multiple source simultaneously (so long as they don't share pins – but sometimes even that can be overcome

with an external multiplexer if your unconventional design calls for it.)

Example 'A' shows the common connection method using a standard quartz crystal wired to the OSCI and OSCO pins. In this configuration you can connect a crystal with a fundamental frequency in the range of approximately 1MHz to 20MHz. The components that implement the actual oscillator circuit are within the processor itself, with the exception of two low-value capacitors required to provide the correct load capacitance to the oscillator.

The oscillator on these pins consumes a relatively large current, which adds significantly to the background current consumption of the circuit. A crystal-based oscillator takes a few milliseconds to startup and an accuracy of 0.05% should be possible.

Example 'B' is a variation on 'A', using a ceramic resonator rather than a

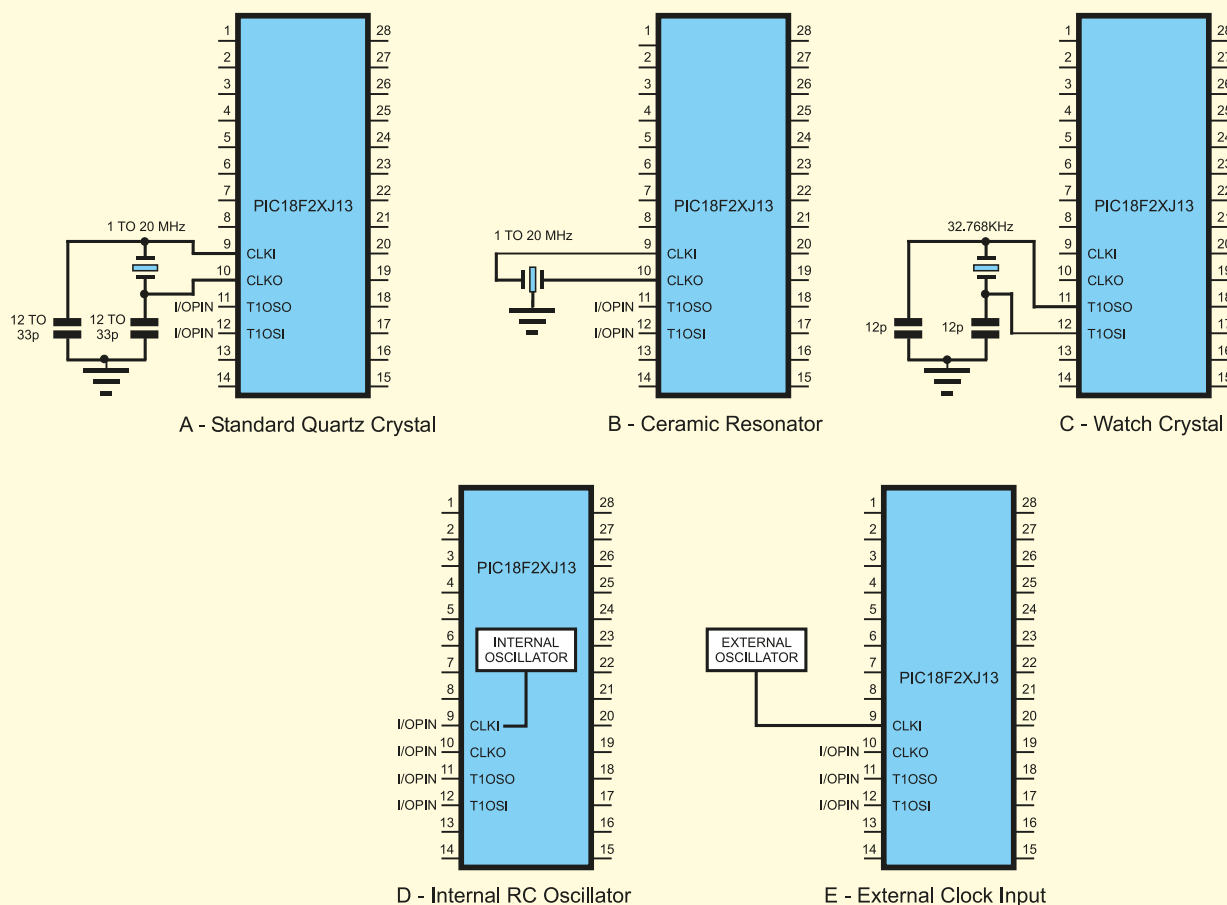

Fig.1. Different clock sources

quartz crystal. Ceramic resonators are typically manufactured with the required load capacitors inside their package, which helps minimise the circuit complexity. Ceramic resonators are cheaper too, but at the cost of less accuracy – about 0.5%, compared to 0.05% for crystals.

A watch crystal, shown in circuit ‘C’ (as fitted in last month’s article) requires a much lower oscillator drive level, which is why it connects to a different set of pins on the processor. This oscillator consumes significantly less power, as we saw. Watch crystals are still based on quartz crystals and so provide a high degree of accuracy. However, oscillators based on watch crystals take a *very* long time to start up, up to several seconds.

The simplest oscillator to use is the one that requires no external components at all; the ‘RC’ oscillator, as shown in ‘D’ in Fig.1. This on-chip circuit uses a resistor and capacitor on the processor die to determine the operational frequency. As no external connections are required, the pins normally used for the oscillator (OSCI and OSCO) are now available for use as standard I/O pins – a useful bonus, if required.

An RC oscillator is not as accurate as a crystal or ceramic one, but with on-chip voltage regulation and factory-based calibration, the PIC RC oscillator can achieve an accuracy of a few percent – quite adequate for many applications, and even serial interface control at lower baud rates (we have no problem operating a UART at 19200 baud.) Power consumption is still higher than a watch crystal. What is more significant, however, is that an RC oscillator will start very quickly. There are actually two RC oscillators within the PIC18F27J13; one providing 31kHz, and one providing 8MHz.

The final oscillator configuration shown in ‘E’ is one where no PIC oscillator is used; the clock is externally provided on a single clock input pin CLKI. This signal can be provided by an external oscillator module (which are expensive and draw lots of power) or even the output from another PIC processor. If you design calls for multiple processors on a single PCB, this can save on cost.

If your design requires a very accurate clock signal, then you could use a TCXO module – a temperature controlled crystal oscillator. Costing several pounds and upwards, these can provide a clock signal accurate to within a few parts per million over a very wide ambient temperature range. Not a typical hobbyist requirement!

There is one other oscillator left to mention; the watchdog timer. Like the RC oscillator, this is a completely on-chip circuit, with a single purpose – to reset the processor if its control register is not written to periodically. It’s very simple, with very limited configuration, and its only purpose is to recover the processor from ‘software lock-ups’ should a problem occur. Being completely on-chip, it runs even if the processor’s main clock has stopped for some un-expected reason. Watchdog timers are a ‘last resort’ means of recovering a rogue program. We will cover their use in a later article, and as they cannot be used for running the processor or peripherals, we will not mention them again in this article.

Balancing the options

It’s becoming clear that we have a number of different design considerations to balance; start-up time, power consumption, accuracy, component count, I/O pins... all quite confusing. There are, however, some simple rules of thumb that can be applied, and a few standard configurations that you can play with.

Do you want to run your design from batteries, and maintain a calendar clock? Then use a watch crystal, as we are at the moment. Not bothered about an accurate time source? Then just use the internal RC oscillator.

Need to run a high speed asynchronous serial link, such as a fast UART or USB? Fit a standard crystal.

What is more of a challenge is deciding how and when you use these clock sources. If you need your circuit to wake up from a low-power mode quickly, such as to respond to an external interrupt within a few milliseconds, then you will need to run from the RC oscillator rather than a crystal oscillator, as a crystal oscillator will take possibly tens of milliseconds to start operating. That, however, can be a problem if you then need to send the result of that interrupt over a high speed UART or USB link.

A solution to that conundrum is to use clock switching. When you are about to put the processor to sleep, ensure the RC oscillator is selected. When the processor wakes from sleep due to an interrupt, the processor will wake quickly. Once you have processed that interrupt, change the operational clock source to the external crystal – it will take a few tens of milliseconds to start up – during which you will continue to operate from the RC oscillator – but once it has started, the processor will switch to it, and you can now operate your fast serial interface. This kind of problem doesn’t arise very often (we’ve only used it once in thirty years) but it’s nice to have the option.

Timer reloading

Let’s get back to the ‘issues’ we had with last month’s real-time clock. It does work, and manages its power consumption very well, but it suffers from one serious drawback – it isn’t very accurate. This is not a fault of the hardware design or our choice of components; it’s to do with the way in which we manage the timer that is providing the one-second ‘tick’. The problem is shown in Listing 1, the original source code from last month.

It looks quite straight forward – clear the interrupt flag, toggle the LED on a count of ten, reload Timer 1 with a one-second timeout value and return. The problem is that between the time of the first interrupt occurring and the ‘movwf TMR1L’ instruction, a lot of time has elapsed.

First, the processor has to re-start its main ‘RC’ oscillator, which can take a few hundred microseconds (remembering that the RC oscillator is turned off to conserve power). Then, the processor must branch to the interrupt vector, and finally seven (or sometimes ten) instructions have to be executed before the one-second timer count is re-initialised. If you are only interested in this timer for generating delays, that is probably fine. If you are trying to maintain a real-time clock, with a few seconds accuracy over the course of months, it isn’t. The clock will run slow.

Now you may be thinking ‘that’s ok, I’ll just adjust the timer reload value.’ But don’t forget that some of the delays are *variable* – the startup time of the RC oscillator will be temperature dependant, and the interrupt routine does not take a fixed amount of time to execute – sometimes seven, sometimes ten instructions. We need a better solution.

Compare mode

As you might expect by now, the timer peripheral provides a solution to our problem. Two solutions in fact. Let’s start with the easy one.

Our original timer design relies on pre-loading the timer with a count of 32767. The timer is configured in 16-bit mode, so the maximum count is 65536; on the next count the timer rolls back to zero, generating our interrupt as it does. Our timer input clock is running at 32.768kHz (32768 counts per second) and thus the pre-load value of 32767 means the interrupt will occur in 1s.

If we simply avoid pre-loading the timer, then it will run continuously, generating an interrupt exactly once every two seconds, independent of whatever our software or RC oscillator is doing. Therefore, if your design can cope with

Listing 1: Last month’s timer interrupt source code

```
; Interrupt routine entry address - always 0x0008
org 8
bcf   PIR1, TMR1IF

; only toggle the LED after 10 interrupts
decfsz delay_1s
goto  int_exit

comf  LATA    ; toggle all bits in PORTB

movlw TOGGLE_LED_TIME
movwf delay_1s ; reset the 10s counter

int_exit:
movlw HIGH TMR1_COUNT_1S
movwf TMR1H
movlw LOW TMR1_COUNT_1S
movwf TMR1L
retfie FAST
```

a real-time clock that updates once every two seconds rather than once a second, we have a perfect solution. The code for this can be seen in Listing 2, and is available for download from the *EPE* website, under this month's article.

The second (and more elegant) solution is to make use of the PIC's 'Enhanced Capture Compare Peripheral', or ECCP. Specifically, the 'compare' part. This is a 'Swiss army knife' of a module, providing a variety of functions, but one of those functions has been designed to solve our particular problem.

The peripheral contains a 16-bit register that can be automatically compared with the Timer 1 count value. When the two match, Timer 1 is automatically reset back to zero, and the process continues. In a way, it is as though our Timer 1 counter will now 'roll over' at 32768 rather than 65536, giving us back our one second tick. Again, without any intervention by software (once the peripheral has been set up for use.)

We would at this point normally show the source code for this better design, and explain its operation. We will not however, as there is an even better way to maintain a real-time clock on the PIC18F27J13 – using the dedicated 'Realtime Clock & Calendar Peripheral' of course!

Dedicated peripheral

It should come as no surprise that Microchip have created a dedicated peripheral for this function, as maintaining a clock is a fairly common use for a processor in an embedded project, and the on-chip hardware required to provide it is rather simple.

By removing completely the need for software to manage the periodic interrupt from the Timer 1 module, the RTCC peripheral reduces the current consumption of the processor even further. It also introduces some extra features (remember the Swiss army knife?) giving calendar translation, including leap year handling, alarm interrupt generation and, more importantly, a calibration feature which allows you to compensate for minor errors in the frequency of the input clock. Again, all without the involvement by software after the initial setup.

We will plumb in the RTCC module next month, when we look at the difficulties associated with adding an LCD display to a low power project, and present a solution – finally providing a useful real-time clock, and presenting us with the personalised bedside alarm clock we have all been waiting for!

Listing 2: A better real-time clock interrupt

```

include <P18f27J13.INC>

CONFIG WDTCN = OFF
CONFIG XINST = OFF
CONFIG IESO = OFF
CONFIG FCMEN = OFF
CONFIG DSWDTEN = OFF
CONFIG OSC = INTOSCPLL
CONFIG CFGPLLEN = ON
CONFIG PLLDIV = 2
CONFIG PLLSEL = PLL96

; RAM addresses of variables
delay_2s EQU 0x00

; Constants
TMR1_CONF EQU 0x8E ; timer is 16bit, TMR1 SOC source, prescale by 1 (None)
TOGGLE_LED_TIME EQU .5 ; time between toggling the LED - 10s

; Set the code address to start of flash -
; this is where the processor will start
; executing instructions from after a reset.
org 0
goto main

; Interrupt routine entry address - always 0x0008
org 8
bcf PIR1, TMR1IF

; only toggle the LED after 5 interrupts
decfsz delay_2s
goto int_exit

comf LATB ; toggle all bits in PORTB

movlw TOGGLE_LED_TIME
movwf delay_2s ; reset the 10s counter

int_exit:
retfie FAST

main:
movlw 0x00
movwf TRISB ; Set PORTB as an output

movlw TOGGLE_LED_TIME
movwf delay_2s

bcf PIR1, TMR1IF
movlw HIGH TMR1_COUNT_1S
movwf TMR1H
movlw LOW TMR1_COUNT_1S
movwf TMR1L

; Enable the 32KHz oscillator on Timer1
movlw TMR1_CONF
movwf T1CON
bsf PIE1, TMR1IE
bsf INTCON, PEIE
bsf INTCON, GIE
bsf T1CON, TMR1ON

loop:
sleep
goto loop

end

```

Laser 

Why tolerate when you can automate?



Home Automation



C-Bus Shop

C-Bus and
C-Bus Wireless



KATS AV transmission
and IR control system



Barix Ethernet based
MP3, communications
and control systems

www.cb-us-shop.com

www.laser.com

Integrators, Installers, Trade
and Retail customers welcome

Laser Business Systems Ltd
Tel: +44 (0) 20 8441 9788
Fax: +44 (0) 20 8449 0430
Email: info@laser.com
16 Garthland Drive, EN5 3BB

Coast

Sorting out your bits and pieces? Check out our E-shop...

...We offer components, modules, kits, Led lighting, musical stuff, Industrial, Contract design, device programming, short-range radio, scientific items ...and some really weird things!

And if we don't have what you need... let us know... we just might add it.

COAST ELECTRONICS
8 HOLWORTH CLOSE
BOURNEMOUTH
BH11 8PF
Tel: 01202 244309

www.coastelect.co.uk

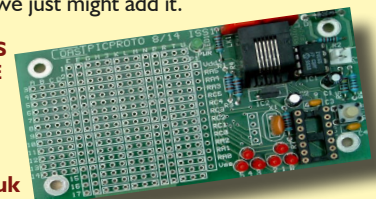

Op amp bandwidth

THIS month, we have a question about op amp bandwidth posted on the *EPE Chat Zone* by **bowden_p**

I wish to put a 200kHz sawtooth waveform through several stages of op amp processing with reasonable fidelity. The incoming amplitude is up to about 0.5V peak-to-peak at about 3:1 rise/fall ratio, and the op amp then applies up to ×3 gain. What op amp gain-bandwidth product (GBP) would be needed for this task?

I believe a sawtooth waveform has both even and odd harmonics, so if say the 6th harmonic is to be passed without much loss, $200\text{kHz} \times 6 \times 3$ is the signal bandwidth = 3.6MHz. The op amp open-loop gain required to pass this without much loss would then be say, a minimum of 10, so the overall GBP comes to 36MHz!

(The op amps would have feedback applied to limit gain to the required ×3 or less.)

1. Is this a good estimate of the GBP required?
2. How does this relate to the unity gain frequency often quoted in spec sheets?

Is this true, or have I lost the plot somewhere?

All comments would be welcome. My forte is not in analogue electronics, but I am trying to understand this area more.

We will look op amp frequency response and GBP in detail, but first it's best to quickly point out that the calculation in the question is not quite right. Assuming that six harmonics is sufficient, as stated, the required bandwidth is $200\text{kHz} \times 6$, which is 1.2MHz. The stated gain is 3, so the implied GBP specification is 3.6MHz.

GBP takes account of the relationship between open and closed-loop gain, so it is not necessary to make an assumption about open gain (as **bowden_p** did by multiplying by 10). However, there are devices which could meet – and beat – the 36MHz GBP requirement if this was really needed.

To fully appreciate the GBP of op amps, we need to know about the frequency response of amps and why they have the response they do. This in turn is related to the use of op amps with feedback to form closed-loop circuits.

Op amps are high-gain, direct-coupled amplifiers. The term 'direct-coupled' means that the op amp's inputs and internal stages are connected directly, not via coupling capacitors; this enables op amps to amplify DC and very low frequency signals.

The output of an op amp, V_o , without any additional external components is given by:

$$V_o = A_{VOL}(V_1 - V_2)$$

where V_1 is voltage on the non-inverting input, V_2 is the voltage on the inverting input (see Fig.1) and A_{VOL} is the open loop voltage gain, which is specified on a device's datasheet and is typically in the range 70dB to 150dB.

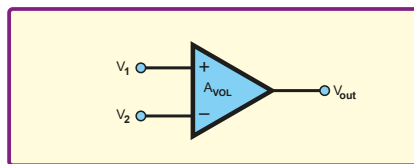

Fig.1. Open-loop op amp

Feedback

Op amps are usually used with negative feedback, often in the inverting or non-inverting amplifier configurations, as shown in Fig.2. Applying negative feedback subtracts a fraction β of the output from the input, so, for the non-inverting configuration, we get:

$$V_{out} = A_{VOL}(V_{in} - \beta V_{out})$$

where V_{out} is the circuit's output voltage and V_{in} is the circuit's input voltage. The gain with feedback (closed loop voltage gain, A_{VCL}) in this configuration is, therefore:

$$A_{VCL} = V_{out}/V_{in} = A_{VOL}/(1 + A_{VOL}\beta)$$

This result is obtained by rearranging the first feedback equation to give V_{out}/V_{in} . For high A_{VOL} (more for specifically βA_{VOL} much larger than 1) the gain of the circuit may usually be approximated to $A_{VCL} = 1/\beta$. Note that the op amp gain does not change when we apply feedback – it is the gain of the whole circuit which is determined by the feedback.

Applying negative feedback means the gain of the circuit is independent of the gain of the op amp, as long as the 'high A_{VOL} ' assumption holds. This is very useful, because the gain of individual op amps of the same type can vary significantly due to manufacturing variations, and with temperature.

However, the gain accuracy of circuits, such as those in Fig.2, is mainly dependent on the resistor tolerance. In a typical circuit a doubling or halving of op amp open loop gain will shift the circuit (closed-loop) gain by much less than the gain variation possible due to using 5% resistors. This is very useful because the op amp user does not have to worry about op amp gain variations.

Instability

Unfortunately, the application of negative feedback to an amplifier may result in instability (unwanted oscillations). This is very undesirable and we need an understanding of how it might occur and what op amp designers do to help prevent it.

The output of an amplifier does not respond infinitely quickly to changes at its input, so any signal fed back from the output to the input will be offset in time with respect to the original input. Consider a simple case in which there is a fixed delay from input to output of the amplifier whatever the input signal does (things are usually more complicated

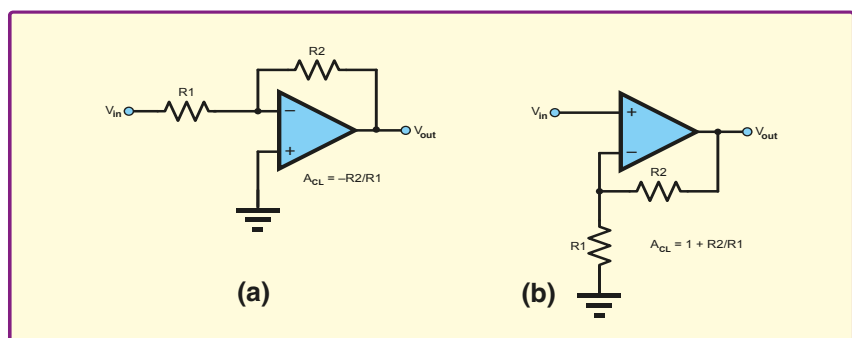

Fig.2. Op amp amplifiers, (a) inverting, (b) non-inverting

than this). Say, for example, this delay was 0.1µs. If the input frequency was 100Hz then this time would be 0.001% of the signal's cycle time and could probably be considered insignificant.

However, at 2.5MHz the 0.1µs delay is a quarter of the signal's cycle time of 0.4µs. This would usually be expressed by saying that the amplifier had a phase shift of 90° at 2.5MHz (one complete cycle of the waveform is 360°). At 5MHz 0.1µs is half the cycle time of the signal. This is a significant point because a phase shift of 180° is equivalent to multiplying the signal by -1.

Consider the total phase shift through the amplifier and feedback network as we increase the input signal frequency – in line with the above argument it will tend to increase. Once the shift reaches 180° we have effectively inverted our feedback signal – what was negative feedback has become positive feedback. Positive feedback is what you need to make an oscillator, so our amplifier may become unstable.

Returning to the closed-loop gain equation from above:

$$A_{VCL} = A_{VOL} / (1 + \beta A_{VOL})$$

If the value of the term $(1 + \beta A_{VOL})$ approaches zero then the value of A_{VCL} will tend towards infinity. That is, infinite closed-loop gain – this results in instability; specifically, the circuit oscillates. The condition for which $(1 + \beta A_{VOL}) = 0$ is $\beta A_{VOL} = -1$. The term βA_{VOL} is referred to as the loop gain.

Since A and β are phasor quantities (they have magnitude and phase shift) we get oscillation when the magnitude of βA is at least one (written $|\beta A| > 1$) and the phase shift due to βA is $\pm 180^\circ$.

Gain and phase margin

Generally, the gain of an amplifier will decrease and the phase shift will increase as frequency increases. The question is – will the above conditions for instability occur as frequency increases? We can measure how close a circuit is to being unstable using the concept of gain margin and phase margin.

1. As βA approaches 1 the phase shift must be less than 180°. The difference between the phase shift at this point and 180° is the 'phase margin'.
2. As the phase shift of βA approaches $\pm 180^\circ$ the magnitude of βA must be less than 1. This difference can be expressed as the 'gain margin' (usually in dB).

Gain margin and phase margin are illustrated in Fig.3, which shows the variation of magnitude (gain) of βA and phase shift of βA with signal frequency. Note that a gain of 1 is 0dB, and that phase shift is negative because the output lags behind the input signal in time. *Please note* – all the frequency response graphs, except Fig.9, are sketches of general form, and are not accurate plots from measurement or simulation of particular circuits.

The larger the feedback fraction β , the more 'difficult' it is to fulfil the gain and phase margin stability criteria because the loop gain is higher. Thus, a circuit could, for example, be stable with $\beta=0.5$ but not with $\beta=1.0$. Some op amps are not stable in circuits below certain gains (eg. 5) and therefore cannot be used in unity-gain circuits (followers). It is easy to get caught out by this if you do not read the datasheet carefully!

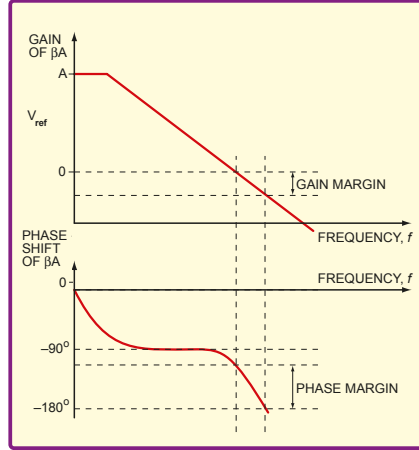

Fig.3. Variation of magnitude (gain) of βA and phase shift of βA with signal frequency, illustrating gain margin and phase margin

The gain of op amps decreases as frequency increases. This decrease in gain with frequency is not arbitrary; it is part of the design of the op amp. Introducing circuitry to modify how gain and phase shift change with frequency in such a way as to ensure stability is known as compensation.

Most op amps are fully compensated internally (so the user does not have to worry about it) but some require external compensation components. This typically allows the user a trade-off between bandwidth and the amount of feedback used.

Poles and zeros

The terms 'pole' and 'zero' often occur when amplifier compensation is discussed. Formal mathematical analysis of frequency dependent circuits uses complex numbers to represent signals and circuit responses (gain etc). Complex numbers are two-part numbers (the parts are called real and imaginary) and are required because signals and circuits must be characterised in terms of both amplitude and phase (a single value is insufficient).

The terms pole and zero refer to what happens to the gain of a circuit at key points in its frequency response, as represented by complex numbers. At a pole, the complex gain becomes infinite, and at a zero it is (perhaps more obviously) zero. Infinite complex number gain does not mean a circuit will output trillions of volts with virtually no input – remember this is a mathematical representation, not what we measure directly on an oscilloscope.

However, this is of practical importance because the measured frequency response may change significantly at frequencies relating to the complex pole and zero points.

In general, above a pole frequency the gain will continue to drop by 20dB per decade (6dB per octave) more than at lower frequencies. Note that a decade is a 10-fold change in frequency and an octave is a halving or doubling of frequency. Fig.4 shows the typical frequency response characteristics of a circuit with a single pole. Note the phase shift tends towards -90° due to the pole (the pole adds -90° of phase shift). The graph uses a log frequency scale so decades will be evenly spaced on the frequency axis.

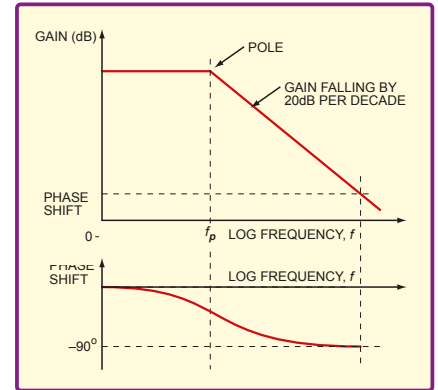

Fig.4. Frequency response due to a single pole

In general, above a zero's frequency the gain will continue to increase by 20dB per decade (6dB per octave) more than at lower frequencies (as frequency increases). Fig.5 shows the typical frequency response characteristics of a circuit with a single zero. The zero adds 90° of phase shift.

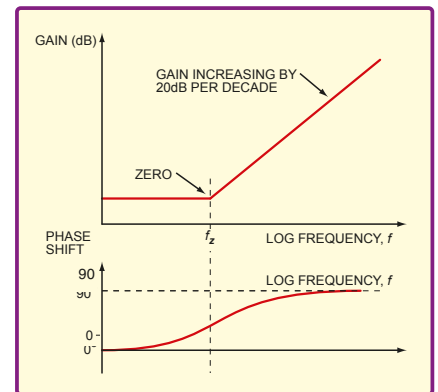

Fig.5. Frequency response due to a single zero

Circuit designers add poles and zeros to a circuit's frequency response in order to optimise its characteristics, such as to improve stability. Fig.6 shows what the frequency response of an op amp might look like without compensation. This (hypothetical) example has two poles at high frequencies, but the gain is still much larger than 1 by the time the phase shift gets to -180° . The circuit would be unstable with feedback.

Dominant pole compensation

If we add a pole at a very low frequency to the circuit with the response shown in Fig.6, the gain will start falling off from this point and will be safely below 1 once the contribution of the pre-existing high frequency poles push the phase shift to -180° . This low frequency pole completely dominates the overall frequency response, so this approach is called ‘dominant pole compensation.’

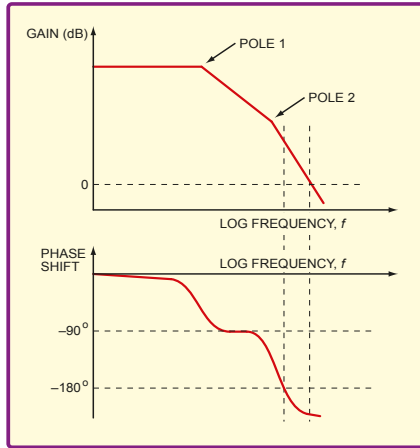

Fig.6. Frequency response of a hypothetical op amp with no compensation showing high frequency poles. This circuit would be unstable with negative feedback

The frequency response of the op amp with dominant pole compensation is shown in Fig.7. Note there is now a healthy phase margin and circuits using negative feedback built with this op amp would be stable.

This can be achieved by placing a negative feedback capacitor around one of the op amp's internal gain stages. As frequency increases the reactance of the capacitor decreases, applying more feedback to the stage, reducing its gain, and hence the gain of the whole op amp.

Fig.8 shows the frequency response of a typical dominant pole compensated op amp for both open-loop and closed-loop conditions. The op amp has full gain at DC, but the point at which the

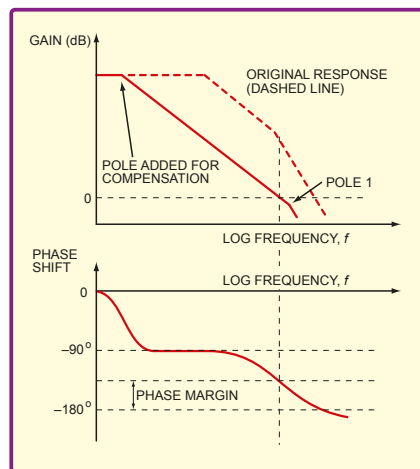

Fig.7. The response of the circuit from Fig.6 with dominant pole compensation added. This circuit would be stable with negative feedback

gain starts dropping (strictly defined as the -3dB point, the dominant pole frequency, f_o) is often at a very low frequency, eg, 1Hz to 10Hz. Above f_o the gain falls off at 20dB per decade.

If we build a circuit using negative feedback, the closed-loop gain will typically be much lower than the open-loop gain. The circuit will have the required closed-loop gain, as set by the feedback resistors, as long as the open-loop gain is much larger than the closed-loop gain (βA_{VOL} much larger than 1, as discussed earlier).

Thus, if we plot the closed-loop gain on the same graph as the open loop gain it will remain flat until it gets close to the falling open-loop gain curve (see Fig.8). After that point the closed loop gain will decrease along with the open-loop gain.

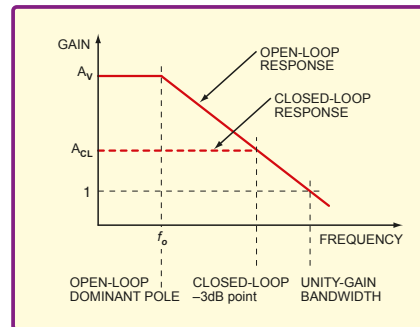

Fig.8. Open and closed-loop frequency responses

As the op amp's gain extends from DC (its gain does not roll off at low frequencies as a capacitively coupled circuit would) the frequency at which the closed loop gain starts dropping off is equal to the circuit's bandwidth at that closed-loop gain.

The lower the closed-loop gain, the higher the frequency at which the closed-loop frequency response intersects the open-loop response and starts decreasing. The closed-loop bandwidth is highest for 100% negative feedback, that is, unity closed-loop gain. This is the unity gain bandwidth of the op amp – the frequency at which the open-loop gain decreases to 1 (also shown on Fig. 8).

If we multiply closed-loop gain by closed-loop bandwidth we get the gain bandwidth product (GBP). A feature of dominant pole compensated frequency responses is that the GBP is constant. Recall that the gain drops by 20dB per decade of frequency for this type of compensation.

Table 1: GBP figures for the LT1002 op amp at various frequencies (using data from Fig.9)

Gain/dB	Gain	Closed Loop Bandwidth	GBP
80	10000	100	1,000,000
60	1000	1,000	1,000,000
40	100	10,000	1,000,000
20	10	100,000	1,000,000
0	1	1,000,000	1,000,000

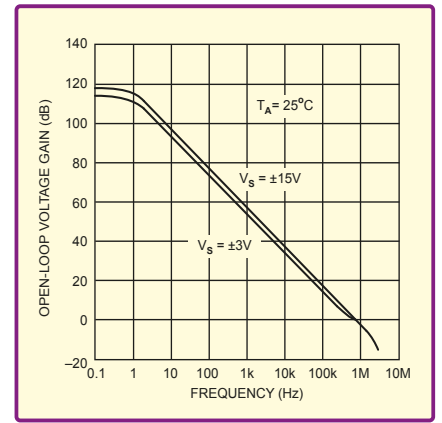

Fig.9. Open-loop frequency response of the LT1002 op amp (from Linear Technology datasheet)

A drop of 20dB is a factor of 10 decrease in gain, but this is for a factor of 10 increase in frequency, thus the product of gain and frequency will be constant. This can be easily illustrated by means of an example. Fig.9 shows the response of a typical op amp, this is a LT1002 from Linear Technology. It is a high precision, but not particularly fast device.

Gain bandwidth product

We can take a few points from Fig.9 and work out the GBP. This is shown in Table 1. The product of gain and bandwidth is one million in each case, which is also the unity gain bandwidth of the LT1002 (1MHz) – which answers **bowden p's** second question – the GBP is equal to the unity gain bandwidth.

Based on the assumption that we have a dominant pole compensated op amp, **bowden p's** requirement for a GBP of 3.6MHz implies an op amp with unity gain bandwidth of 3.6MHz. Clearly, the LT1002 is not suitable; however, there are plenty of higher frequency op amps that can meet this specification.

Not all op amps use dominant pole compensation. Other compensation techniques are used to achieve improved performance in some op amp designs. There was some discussion of the Motorola MC33274 op amp on the *EPE Chat Zone* in response to **bowden p's** post. It was also pointed out that its GBP did not fit the expected pattern.

Consulting the datasheet quickly shows that this device uses dual-doublet frequency compensation rather than dominant pole, and, therefore, it should not be assumed that it has constant GBP or that the GBP equals the unity gain bandwidth.

INTERFACE

USB supply problems

EARLY home computers often had expansion ports that could supply a variety of voltages, which in some cases included a negative one, and usually included at least one positive potential that was higher than the normal +5V logic supply. The maximum currents available were often quite limited, but were adequate for many purposes.

USB 1.1 ports are less accommodating, with just a single +5V supply and a maximum available current of 0.5A. Higher currents are available from later versions such as USB 2.0, but a maximum of only 0.1A can be drawn from some USB ports on passive hubs and battery-powered devices.

Where an interface requires something more than one or two watts of power, it is probably best to abandon the USB port's supply and settle for a custom mains supply unit. The same might also be true if the total power required is not all that high, but a variety of positive and negative potentials are required.

Ready-made

In most cases though, any additional low-power supply rails can be derived from the USB port's +5V supply using one or more DC-to-DC converters. Various ready-made DC-to-DC converters are available, and while I do not usually support the ready-made approach over the home-constructed alternative, an 'off the shelf' DC-to-DC converter can have advantages.

A ready-made converter can be very much cheaper where anything other than quite modest supply currents are involved. The components for home constructed alternatives can be difficult to track down, and expensive when you can find a source of supply.

The situation is different when currents of a few milliamps or less are involved, and a large step-up from the basic 5V supply is not required. This type of thing can usually be handled using relatively simple and inexpensive circuits that do not require any special inductors or transformers.

Sometimes, a small negative supply potential with a maximum supply current of a milliamp or two is required. For example, some analogue-to-digital converters require a supply of this type for an internal operational amplifier (op amp). In a similar vein, some interface circuits require an operational amplifier to provide output voltages right

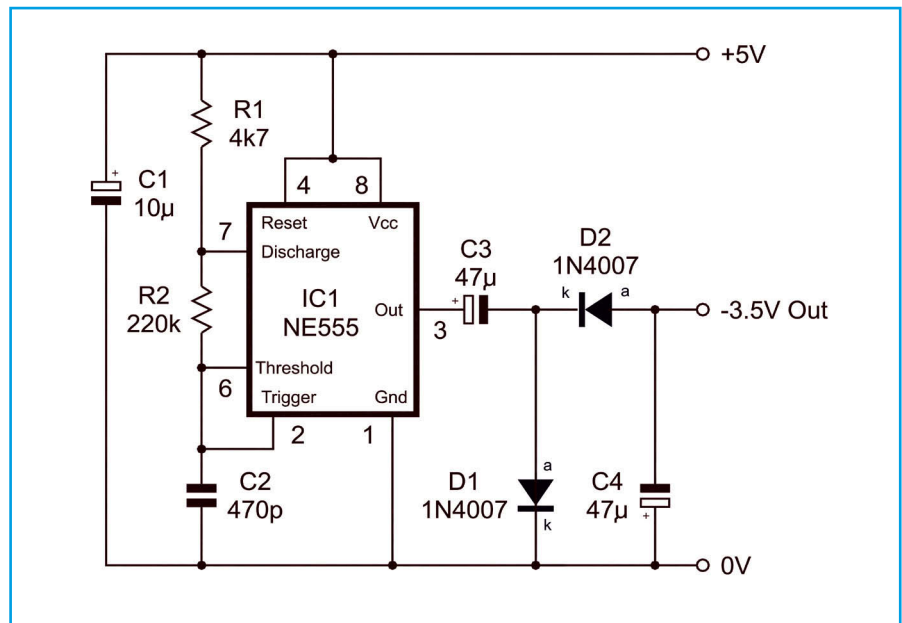

Fig.1. A simple negative supply generator using a 555 oscillator and a rectifier circuit. Using Schottky diode rectifiers for D1 and D2 will give a slightly higher output voltage

down to the 0V rail. While there are a few op amps that can do this without the need for a negative supply, some loss of accuracy might be involved.

Negative thoughts

The more reliable method is to use a precision operational amplifier together with a negative supply potential. This type of thing does not really merit dual balanced supplies, since the op amp will not be required to produce negative output potentials. It just needs a sufficiently high negative supply voltage to permit output potentials right down to 0V to be produced accurately. This typically requires a negative supply of about -3V or so.

A simple way of producing a negative supply is to use an oscillator driving a rectifier and smoothing circuit, as shown in Fig.1. The oscillator is a simple 555 astable circuit that produces a roughly squarewave output signal at pin 3 of IC1. The timing components are resistors R1, R2, and capacitor C2, and these set the operating frequency at a little under 7kHz.

In this application, the exact frequency is unimportant, but a relatively high figure makes it easier to smooth the rectified DC signal. On the other hand, making the operating frequency too high can produce inefficiencies in the rectifier circuit. A frequency of anything in the region of 10kHz should

give good results. C3 couples the output signal to a conventional rectifier and smoothing circuit (D1, D2, and C4).

The negative output voltage from a circuit of this type will always be significantly less than the positive supply used to power the circuit. One reason for this is that the output voltage swing from the oscillator is likely to be slightly less than the supply voltage, and there is also the forward voltage drops through the diode rectifiers to take into account.

It also has to be borne in mind that loading on the output will exacerbate these factors, and reduce the output voltage still further. With the output loaded by a few milliamps there will typically be about -3.5V at the output of the circuit.

This can be boosted slightly by using Schottky rectifiers for D1 and D2, which have lower forward voltage drops than normal silicon rectifiers. However, the loaded output voltage from a circuit of this type is never likely to be much more than about -4V.

Although this circuit should work using any 555 timer IC, some of the low-power versions lack the output drive capability of the standard device, and might not work as well. The circuit is shown as working from a +5V supply, but it will work with any supply potential from +5V to +12V, and the negative output supply will always be a volt or so less than the positive supply level.

Positive thoughts

Although most logic devices will operate quite happily from a standard 5V logic supply, the same is not true of linear circuits. It may be possible to obtain the desired result using special operational amplifiers and other linear devices that will work from low supply voltages, but it is sometimes necessary to use a slightly higher supply potential in order to get good results from the linear section of an interface. This might require a supply voltage that is much higher than the 5V logic type, but a small boost is often sufficient.

A boost in voltage can be obtained using a circuit that is essentially the same as the one for generating a negative potential, but with some changes to the smoothing and diode rectifier circuit (Fig.2). As before, an oscillator based on a 555 timer chip is used to generate a 7kHz squarewave signal, and capacitor C3 couples this signal to a rectifier and smoothing circuit.

However, in this case the rectifier circuit produces a positive output voltage rather than a negative type, and this voltage is referenced to the +5V supply rather than the 0V ground rail. Therefore, it effectively adds about 3.5V to the 5V supply, giving an output that is about 8.5V positive of the 0V rail. This circuit will work properly with supply voltages from 5V to 12V, and it produces an output potential that is roughly equal to 1.5V less than double the supply potential.

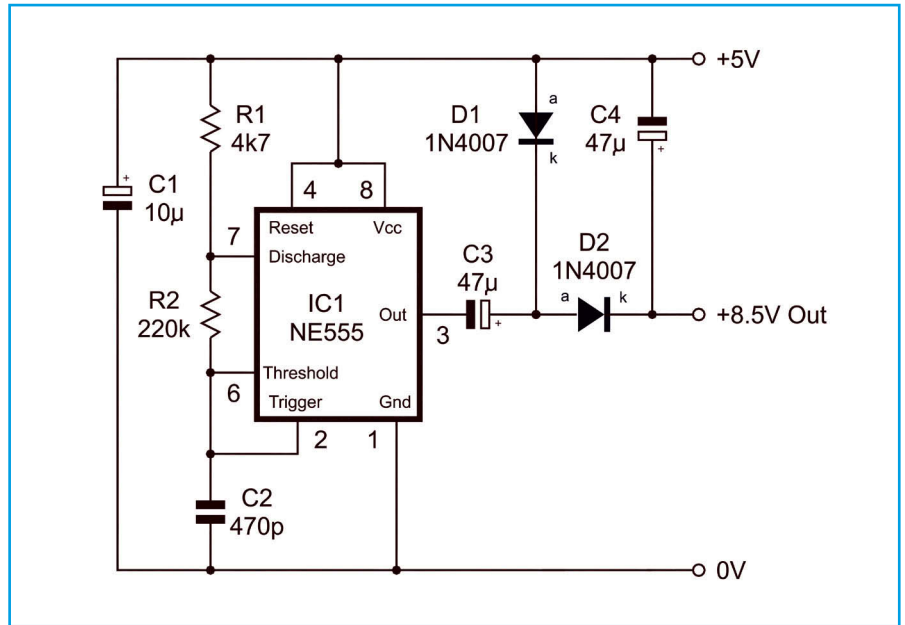

Fig.2. This circuit uses a 555 oscillator and a rectifier circuit to give a boosted positive supply. As with the circuit of Fig.1, it is only suitable for supply currents of a few milliamps

Pumping up

There are chips specially designed for low-power DC-to-DC conversion, and these are generally more efficient than circuits that rely on an oscillator and a rectifier. Chips of this type use a different principle known as ‘charge pumping’.

Fig.3 shows the basic way in which a charge pump circuit can generate a negative output potential that is equal

to the positive input potential. There are two pairs of ‘electronic’ switches that have anti-phase control signals. When S1 and S2 are closed, S3 and S4 are open, and vice versa. Also, there are two capacitors, which are the pump capacitor (C1) and the reservoir or smoothing capacitor (C2).

Initially (Fig.3a), S1 and S2 are closed, connecting pump capacitor C1 to the input supply. S3 and S4 are open, leaving reservoir capacitor C2 unconnected. Of course, with C1 connected to the input supply it will rapidly charge to the supply voltage.

On the next phase of the control cycle (Fig.3b) S1 and S2 are opened, and the supply is disconnected from C1. Switches S3 and S4 are closed though, and C1 is connected to C2. Capacitor C1 therefore transfers some of its charge to C2. This process continues on successive clock cycles, with the charge on C1 being partially transferred to C2, and the potential on C2 being ‘pumped’ up to the full supply voltage. Provided the output current is kept at reasonable levels, the circuit will maintain this output level with a minimal amount of ripple on the output.

An important point here is that the charge on C2 is negative relative to the 0V supply rail, and that a negative output voltage equal to the positive supply voltage is produced. With some slight reworking it is possible to produce a charge pump that produces an output signal that is positive over the positive supply rail. In other words, the same basic scheme of things can be used to provide a voltage doubler.

Less than perfect

Although charge pump circuits are generally more efficient than the oscillator and rectifier variety, they are still less than perfect in operation, and the negative output voltage will always fall short of the positive supply potential. The

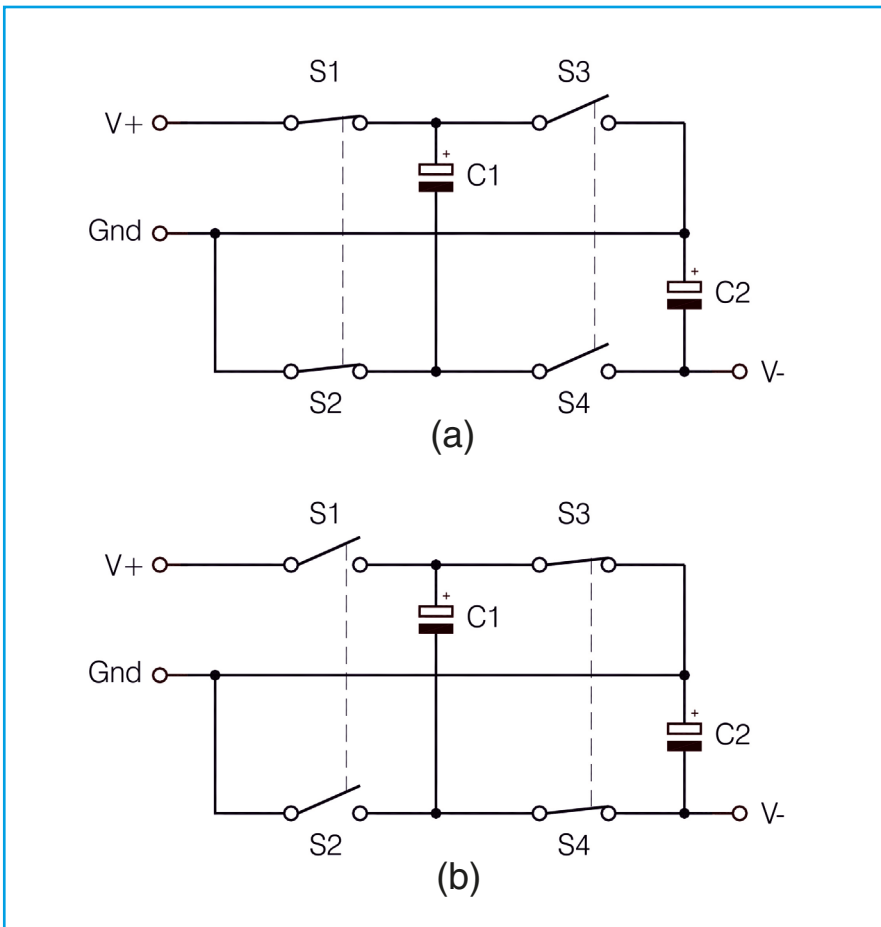

Fig.3. A basic charge pump circuit uses two capacitors and four electronic switches to generate a negative supply. C1 is the pump capacitor and C2 is the reservoir

main reason for this is that the electronic switches, unlike their mechanical counterparts, have a significant resistance when in the 'on' state. This produces a voltage drop when a supply current is drawn, and the higher the load current, the lower the output voltage. The circuit for a negative supply generator, based on the ICL7660 chip, is shown in Fig.4. C2 is the reservoir capacitor and C3 is the pump capacitor. C1 helps to reduce high frequency noise and ripple on the negative output supply.

This circuit is not restricted to 5V operation, it will work with supply voltages as low as 3V, and as high as 10V. The negative supply has a source resistance that is no more than 100Ω at room temperature, and is typically only about half that figure.

This equates to a voltage drop of no more than 1V per 10mA of output current, and typically about 0.5V per

circuit of Fig.2 provides a cheaper way of obtaining much the same result. It is worth noting that there are improved versions of the ICL7660 that provide much lower source resistances. The MAX660 for instance, has a typical source resistance of just 6.5Ω. With a 5V supply this equates to a typical output voltage of 4.35V with an output current of 0.1amps, and 4.935V with an output current of 10mA.

Balancing act

True voltage doubling is not within the repertoire of the ICL7660, but there are other charge pump chips that can do this and more. The MAX680 for example, can provide positive and negative voltage doubling to produce dual 10V supplies from a single +5V supply. The basic circuit for the MAX680 is shown in Fig.5. Capacitors C6 and C2 are the

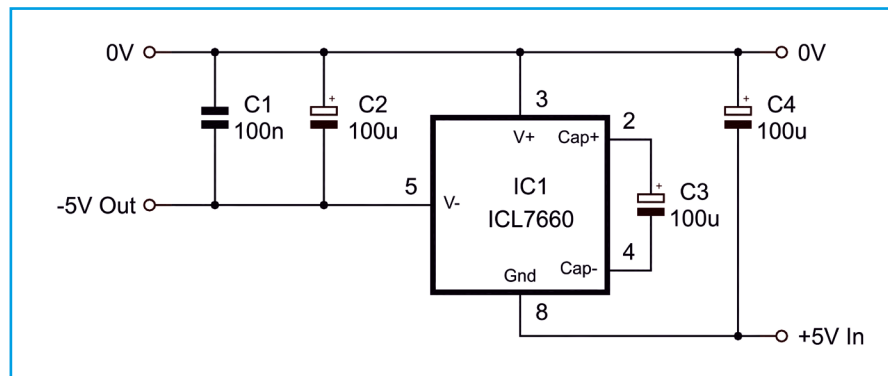

Fig.4. A simple charge pump circuit based on an ICL7660. It provides a -5V supply that has a maximum source resistance of 100Ω (typically 55Ω)

10mA drawn from the output. In a typical application with (say) an output current of 5mA, the output voltage would be no less than -4.5V, and would probably be about -4.75V.

The ICL7660 can be used as a supply voltage doubler, but it does not seem to be capable of providing this action using the charge pump system. The relevant application circuit in the data sheet seems to use it as an oscillator driving a rectifier and smoothing circuit. The

reservoir capacitors for the positive and negative supplies respectively. Two pump capacitors are required, and these are C3 and C7.

As one would probably expect, the source resistances of the two supplies are relatively high with a typical figure of 150Ω. With an output current of (say) 5mA drawn from each supply this typically gives dual 9.25V supplies, which is more than adequate for most op amps.

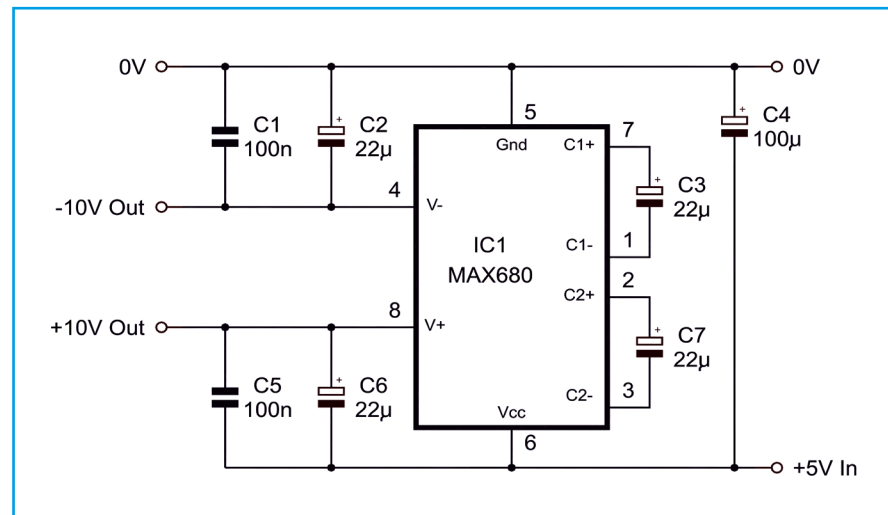
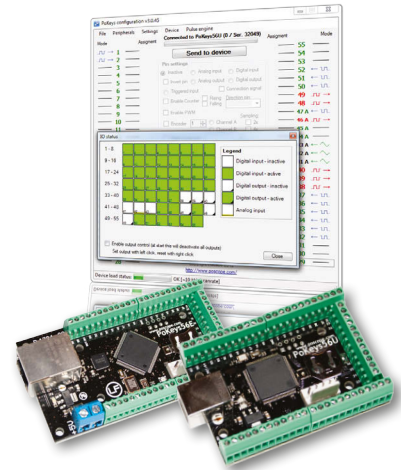

Fig.5. The MAX680 can provide dual 10V supplies from a single +5V source. The output voltage is typically +8.5V at the maximum recommended output current of 10mA

Need a small and cost-effective device? Look no further.



PoKeys

- Smallest and worlds most flexible USB HID or ETHERNET I/O Interface
- Keyboard and joystick simulator (USB)
- 55 digital I/O (configurable)
- LCD and LED matrixes driver
- 6 PWM outputs, 26 encoder inputs
- Support up to 10 I2C, up to 27-Wire sensors, up to 7 analog sensors
- Expandable with PoNET
- Free software and web interface (ethernet)



PoScope Mega1+

- Smallest USB 2.0 portable 1MS/s oscilloscope
- Data acquisition of analog and digital signals
- Data recording
- Export to CSV, XLS, PDF and HTML
- Simple usage of advanced features
- Examples for C++, VB, Delphi and LabView
- Free software and updates



Visit us at www.poscope.com

EPE PIC PROJECTS VOLUME 2 CD-ROM

A plethora of 20 'hand-PICked' PIC projects from selected past issues of *EPE*. Together with the PIC programming software for each project.

The projects are:

BioPIC Heartbeat Monitor

Take a peek at the rhythmic waveforms that keep you ticking

EPE Moodloop

Have a relaxing 'field-day' (or night) with our PIC-based brainwave generator!

EPE Morse Code Reader

Multi-function Morse Code translation and learning aid; standalone plus optional PC interface!

Freebird Glider Control

An automatic flight attitude control system for your free-flight model glider!

IC Tester

Let a PIC and PC check the health of your digital logic chips!

Interior Lamp Delay

Don't you just hate being plunged into darkness when the car door shuts? Here's a solution! Plus lights-on alarm and battery saver!

Multi-Channel Transmission System

An 8 to 16-channel 2-wire PIC-based signalling link, with optional interface for private phone systems!

Musical Sundial

When the sun has got his hat off (hip-hip-hip-hooray) there's no shadow of doubt you'll find fun with our PIC-based garden gnomon!

PIC-A-Colour Game

PIC your wits against a colourful code-setting mastermind!

PIC-based Brainbot Buggy

A low-cost, easy-build buggy that has a mind of its own!

PIC-based Fido Pedometer

Keeping track of how far you've walked!

PIC-based Intelligent Garden Lights

An easy-to-build lights controller that knows when it's time to switch off!

PIC-based Remote Control IR Decoder

Allows PIC programming enthusiasts to remotely control their designs!

PIC-based Monitored Dual PSU

Workshop power supply with multiple options and monitoring of voltage and current using a PIC microcontroller plus LCD readout!

PIC Pocket Battleships

Become a Sea Lord with our interpretation of the age-old pen and paper game!

PIC Random LED Flasher

Enjoy the fun of an interesting and attractive pattern display!

PICronos LED Wall Clock

Ancient and modern techniques display timely brilliance on a grand scale!

PIC Virus Zapper MK.2

An alternative method that could keep those bugs at bay!

Time and Date Generator

Add time and date codes to your CCTV security monitor!

Water Monitor

How costly is it to keep your garden watered? Find out and control it!



**ONLY
£14.75**
INCLUDING
VAT and P&P

NOTE: The PDF files on this CD-ROM are suitable to use on any PC with a CD-ROM drive. They require Adobe Acrobat Reader

EPE PIC PROJECTS VOL. 2 CD-ROM ORDER FORM

Please send me (quantity)

EPE PIC PROJECTS VOL 2 CD-ROM

Price £14.75 each – includes postage to anywhere in the world.

Name

Address

.....

.....

..... Post Code

I enclose cheque/P.O./bank draft to the value of £

please charge my Visa/Mastercard/Maestro £

Card No.

Card Security Code

(The last 3 digits on or just under the signature strip)

Valid From Expiry Date

Maestro Issue No.



SEND TO:

Everyday Practical Electronics,

Wimborne Publishing Ltd.,

113 Lynwood Drive, Merley, Wimborne,

Dorset BH21 1UU.

Tel: 01202 880299. Fax: 01202 843233.

Email: orders@epemag.wimborne.co.uk

Payments must be by card or in £ Sterling – cheque or bank draft drawn on a UK bank.

Normally posted within seven days of receipt of order.

Send a copy of this form, or order by letter if you do not wish to cut your issue.

**Order on-line from
www.epemag.com
or by Phone, Fax, Email or Post.**

BECOME A PIC PROJECT BUILDER WITH THE HELP OF EPE!

RKAT40

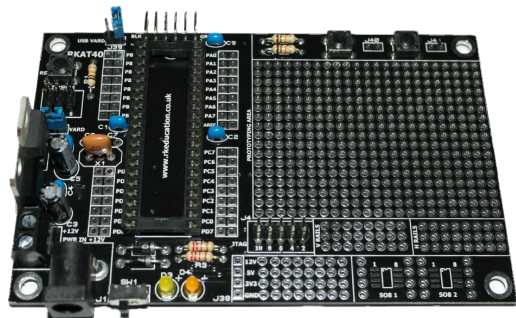

Prototype PCB designed for use with Atmel MCUs

- Designed for use with 40 pin Atmel
- Large prototyping area with power rails
- SO8 breakouts and tactile switch I/Ps
- Power supply circuit
- Interface header for FT232 cable
- ICSP and JTAG headers
- **Only £9.99**

Available now online from,
www.rkonlinestore.co.uk

A wide range of electronic projects are available

SHERWOOD ELECTRONICS

Buy 10 x £1 Special Packs and choose another one FREE

SP1	15 x 5mm Red Leds	SP131	2 x TL071 Op-amps
SP2	12 x 5mm Green Leds	SP133	20 x 1N4004 diodes
SP3	12 x 5mm Yellow Leds	SP134	15 x 1N4007 diodes
SP5	20 x 5mm 1 part Led clips	SP135	5 x Miniature slide switches
SP6	15 x 3mm Red Leds	SP137	4 x W005 1.5A bridge rectifiers
SP7	12 x 3mm Green Leds	SP138	20 x 2.2/63V radial elect caps
SP8	10 x 3mm Yellow Leds	SP142	2 x Cmos 4017
SP9	20 x 3mm 1 part Led clips	SP143	5 Pairs min. croc.clips (Red+Blk)
SP10	100 x 1N4148 diodes	SP144	5 Pairs min. croc.clips (assorted colours)
SP11	30 x 1N4001 diodes	SP146	10 x 2N3704 transistors
SP12	30 x 1N4002 diodes	SP147	4 x 8mm Red Leds
SP18	20 x BC182B transistors	SP151	4 x 8mm Green Leds
SP20	20 x BC184B transistors	SP152	4 x 8mm Yellow Leds
SP23	20 x BC549B transistors	SP153	4 x 8mm Yellow Leds
SP24	4 x Cmos 4001	SP154	15 x BC548B transistors
SP25	4 x 555 timers	SP155	6 x 1000/16V radial elect. caps
SP26	4 x 741 Op-amps	SP160	10 x 2N3904 transistors
SP28	4 x Cmos 4011	SP161	10 x 2N3906 transistors
SP29	4 x Cmos 4013	SP164	2 x C106D thyristors
SP33	4 x Cmos 4081	SP165	2 x LF351 Op-amps
SP34	20 x 1N914 diodes	SP166	20 x 1N4003 diodes
SP36	25 x 10/25V radial elect caps	SP167	5 x BC107 transistors
SP37	12 x 100/35V radial elect caps	SP168	5 x BC108 transistors
SP38	15 x 47/25V radial elect caps	SP172	3 x Standard slide switches
SP39	10 x 470/16V radial elect caps	SP173	10 x 220/25V radial elect caps
SP40	15 x BC237 transistors	SP174	20 x 22/25V radial elect caps
SP41	20 x Mixed transistors	SP175	20 x 1/63V radial elect caps
SP42	200 x Mixed 0.25W CF resistors	SP177	8 x 1A 20mm quick blow fuses
SP47	5 x Min. PB switches	SP178	8 x 2A 20mm quick blow fuses
SP49	4 x 4 metres stranded core wire	SP181	5 x Phono plugs - assorted colours
SP102	20 x 8 pin DIL sockets	SP182	20 x 4.7/63V radial elect caps
SP103	15 x 14 pin DIL sockets	SP183	20 x BC547B transistors
SP104	15 x 16 pin DIL sockets	SP186	6 x 1M horizontal trim pots
SP109	15 x BC557B transistors	SP187	3 x Cmos 4066
SP112	4 x Cmos 4093	SP192	3 x 10mm Yellow Leds
SP115	3 x 10mm Red Leds	SP195	6 x 20 pin DIL sockets
SP116	3 x 10mm Green Leds	SP197	5 x 24 pin DIL sockets
SP118	2 x Cmos 4047	SP198	4 x 2.5mm mono jack plugs
SP124	20 x Assorted ceramic disc caps	SP199	4 x 2.5mm mono jack sockets
SP130	100 x Mixed 0.5W CF resistors	SP200	4 x 2.5mm mono jack sockets

RESISTOR PACKS - C.Film

RP3	5 each value - total 365 - 0.25W	£3.65
RP7	10 each value - total 730 - 0.25W	£4.95
RP10	1000 popular values - 0.25W	£7.00
RP4	5 each value - total 305 - 0.5W	£4.65
RP8	10 each value - total 610 - 0.5W	£7.40
RP11	1000 popular values - 0.5W	£10.15

Catalogue £1.25 inc. P&P or **FREE** with first order.

P&P £2.50 per order. **NO VAT**

Cheques and Postal Orders to:

Sherwood Electronics,
10 NEWSTEAD STREET,
MANSFIELD, NOTTS.
NG19 6JJ

pico[®]
Technology

WORLD'S FIRST USB 3.0 OSCILLOSCOPE



**WIN
YOURS
ONLINE**

www.usb3scope.com/TR115

PicoScope	3207A	3207B
Bandwidth	250 MHz	250 MHz
Sampling	1 GS/s	1 GS/s
Memory	256 MS	512 MS
Signal generator	Function generator	AWG
Price	£1099	£1199
Power supply	From USB port	
Compatibility	USB 2.0 & 3.0	

ALL MODELS INCLUDE PROBES, FULL SOFTWARE AND 5 YEAR WARRANTY. SOFTWARE INCLUDES MEASUREMENTS, SPECTRUM ANALYZER, FULL SDK, ADVANCED TRIGGERS, COLOR PERSISTENCE, SERIAL DECODING (CAN, LIN, RS232, PC, FLEXRAY, SPI), MASKS, MATH CHANNELS. ALL AS STANDARD, WITH FREE UPDATES.

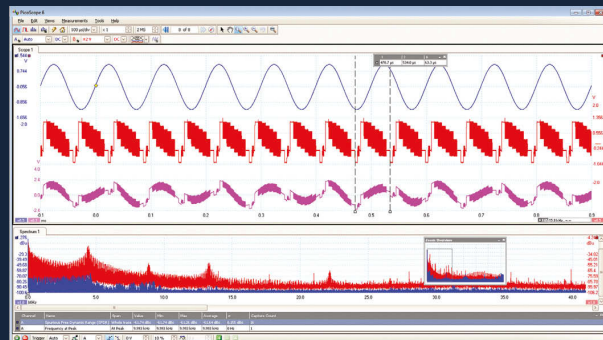

READOUT

Matt Pulzer addresses some of the general points readers have raised. Have you anything interesting to say? Drop us a line!



WIN AN ATLAS LCR ANALYSER WORTH £79

An Atlas LCR Passive Component Analyser, kindly donated by Peak Electronic Design Ltd, will be awarded to the author of the Letter Of The Month. The Atlas LCR automatically measures inductance from 1mH to 10H, capacitance from 1pF to 10,000µF and resistance from 1Ω to 2MΩ with a basic accuracy of 1%. www.peakelec.co.uk

All letters quoted here have previously been replied to directly

Email: editorial@wimborne.co.uk

★ LETTER OF THE MONTH ★

Valves, punch cards and 'beetles'

Dear editor

Further to Max's comment: 'young folk have it too easy these days', I thought – being an 'old folk' – I would share some of my experiences from my 40+ years in the electronics and computing business.

I started my working life in 1962 as a junior research technician in the Geology & Mineralogy Department of Aberdeen University. Most things were still valve-driven in those days. We did a lot of X-ray analysis of rocks and minerals, which required a heap of subsequent calculations that were done initially by hand using a huge Friden electromechanical desk calculator full of gears and spinning dials.

A Sharp electronic calculator, which was not a lot smaller, but was a lot lighter replaced this. It used Nixie tubes for its display and contained an awful lot of transistors. After this, we graduated to using the university mainframe, which was situated in a different part of town.

Punch cards were loaded with the data (a very tedious process), and the stack of cards was sent off to the mainframe. Some time later, a sheaf of fanfold paper arrived back, either containing the results you were looking for, or a pile of waste paper. If it was the latter, the whole process had to be repeated.

In 1970, I went to work for the British Aircraft Corporation (Guided Weapons Division) in Stevenage, Hertfordshire, where I spent 13 years in Electronics Design & Development.

They had a digital mainframe computer and an analogue computer on site. The mainframe operated on the now familiar system of 'punch cards in and lots of paper out', while the analogue computer had rows and rows of pots and meters.

Pocket calculators appeared in the early 1970s, but were horrendously expensive. The engineering department asked all the engineers in the company if they would like to have one and offered, if the response was good enough, to bulk buy from Commodore one of their scientific models. We all got one for the sum of £35 each – equivalent to about £230 in current money! Who would spend that much on a pocket calculator today? I still have that calculator, and it is in good working order. All I have had to replace are the rechargeable batteries. As an aside, years later, while working in Los Angeles, I worked alongside one of the guys who had worked for Rockwell on the design of the LSI chip used in the calculator.

One of the company's products had a digital computer, which was used for guidance calculations. It was housed in a large box with a great number of plug-in boards with a huge number of Texas Instruments 63 series logic devices. It was a fully functional digital computer with accumulators, an ALU, ADCs and DACs.

All of the computer functions were realised using discrete logic devices, the most complex being a J-K flip-flop. These devices were contained in small packages with 14 or 16 legs and were known as 'beetles'. They were not soldered to the boards – each leg was spot-welded! Program storage was via magnetic core memory and the whole thing was less powerful than one of today's small PIC devices.

The next great thing to arrive was a 'Daisy Logician', which was an 'Engineering Workstation'. I went on a weeklong course to learn how to drive it. It could simulate logic systems and was not at all user friendly. Designs and data were stored on eight-inch floppy disks (I think I still have one in my filing cabinet).

In 1977, our department acquired a Commodore PET, the only one in the whole company, and there was a long queue to use it. Things have certainly changed since then.

My first encounter with a micro-processor was around 1978, when I met the Motorola MC6809. We couldn't use them in designs for manufacture, because they weren't suitable for use in the demanding environment of the products that we made, but they were used in the lab for various test setups.

I built my first home computer using one of these. It had 1k of static RAM and 8k of EPROM. I wrote an operating system for it in assembler, all hand-coded and hand-assembled on sheets of paper. It had a cassette interface for program storage and the I/O was by means of a teletype station. Doing it this way certainly gave you an insight into the microprocessor itself. When it was eventually replaced, it had a keyboard and a CRT display, 8k BASIC, 16k RAM and dual 5.25-inch floppy disks.

The first microprocessor we used in a product was a Texas Instruments SPB9900, this was a strange beast using an I²L process, but it could cope with the military temperature range and was radiation hardened. The development system for it filled a large air-conditioned office. The devices themselves were exceedingly expensive.

When you look at what is available to anyone these days, I certainly agree with Max – 'young folk' certainly have it too easy these days!

Ian King, Grimoldby, Louth

Matt Pulzer replies:

Fascinating stories Ian, thanks very much for sharing them with us.

Measuring semiconductor junction capacitances

Dear editor

I read your capacitance meter project in the January 2013 issue of *EPE* with interest – one observation I'd like to make is that like all digitally-

based capacitance meters that feed a switching signal to a capacitor, the voltage across the capacitor is alternating between, typically, zero and 5V. This is unsuitable for measuring the capacitance of a semiconductor junction, which varies considerably with bias voltage.

My own approach in developing a capacitance meter was to combine a sinewave oscillator with switched frequencies between 15.9Hz and 15.9kHz, which was attenuated and buffered to give a 100mV rms signal. The capacitor under test is inserted between this output signal and a

current-sensing resistor to ground. The voltage across this sense resistor is amplified and buffered to drive a meter directly (for a stand-alone unit), or to be connected to another meter (in my case, this happens to be an old Avometer 8 set to measure 3V).

Originally, the intention was to feed the capacitor into a virtual earth amplifier, but this approach gave considerable instabilities that were not solved. Using a sense resistor does limit the accuracy a little, but as the resistor impedance is low compared with the impedance of the capacitor, the effect on the reading is very small, typically only 1%. (Note that the net impedance is the square root of the sum of the squares, which means that the higher impedance of the two dominates more than a simple linear combination would suggest.)

Although 100mV is still rather high, peaking at 141mV, the meter gave comparable readings to an Agilent LCR meter for a small-signal silicon transistor whose collector capacitance is around 5pF at zero DC bias. For more accurate readings, the voltage should be reduced to 10mV, but that would need greater amplification in the measurement stage.

My unit has four frequency ranges and a range switch to alter the sense resistor for either 10kΩ or 1Ω. This gives a total of eight ranges, with full scales between 100pF and 1μF.

John Ellis, by email

Matt Pulzer replies:

Your measurement system sounds most impressive John. The project you refer to is limited to measuring 'ordinary capacitances' associated with connectors, switches and other similar components. As you correctly point out, measuring the capacitance of a semiconductor junction is a more complicated undertaking

Thank you!

Dear editor

Thank you, thank you, thank you for your excellent *Guide To Soldering* [by Alan Winstanley, available to readers at: www.epemag.wimborne.co.uk/solderfaq.htm]. I received my copy with a soldering iron kit that I ordered on the Internet.

It seems that Alan alone on the planet has achieved what I thought never existed; a readable, intelligent and accurate set of instructions. He has obviously been the victim of awfully worded 'directions for use', just as I have.

I'm 65, and poor instructions have been a life-long problem that I have been unable to do much to remedy. But he has risen above the crowd and should be awarded some kind of medal.

It seems that most companies give the writing of instructions for their products to the last person to enter their businesses, probably a 16-year-old, who has no grasp of English, no sense of what 'step-by-step' means, and no interest in what they are doing – all backed up with management's general disinterest in customer service.

I regularly hear complaints about flat-pack furniture instructions, seemingly written by someone whose first language is not English, causing immense frustration, but amazingly nobody does anything about it.

Thank you again and I hope Alan has many years of fruitful 'instructions' writing.

Name supplied

Matt Pulzer replies:

We are delighted you found Alan's guide so helpful. Naturally, we commend it to all our readers as not only an excellent introduction for those new to electronics, but also as a handy refresher for the more experienced

Sourcing software

Dear Editor

I greatly enjoyed Part 1 of the *Universal USB Data Logger* article in the December issue of *EPE*. This is just the kind of

challenging construction project that we readers need, with many potential applications.

However, I was disappointed to realise that *EPE* is not releasing the source code for the embedded Atmel micro used in the logger. Without that, we are reduced to being just 'FoxCon' constructors, and the educational value of the project is largely lost. It also means there's no chance of improving or modifying this promising data logger concept at the informed-reader level – which could lead to valuable follow-on activity for the magazine and its audience. Most other popular electronics magazines I am familiar with, such as *Elektor* or *Circuit Cellar*, make a point of always providing the source code for their projects.

**Chris Morris, Vancouver, Canada,
by email**

Matt Pulzer replies:

Thank you for your letter and I am pleased you enjoyed the Data Logger project.

I quite understand your frustration over software. The project comes from our partner publication Silicon Chip in Australia, and we are obliged to follow their lead when it comes to projects – they did not release the software so we can't.

We did feel though that despite this drawback, the project is of sufficient interest (and use) to readers that we would stick with publication. Thanks again for your feedback

**IF YOU HAVE A SUBJECT YOU WISH TO
DISCUSS IN READOUT
PLEASE EMAIL US AT:**

editorial@wimborne.co.uk

**e CRICKLEWOOD
ELECTRONICS**
Established 1981



Frustrated with your supplier?
Visit our component packed
website for a vast range of
parts - old and new,
many unavailable elsewhere!
www.cricklewoodelectronics.com

1000's OF PRICES REDUCED!

Alternatively phone us on
020 8452 0161 with your
requirements.

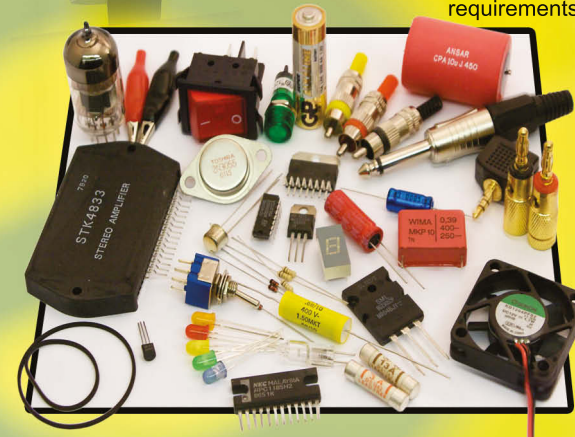

**Visit our Shop, Call or Buy online at:
www.cricklewoodelectronics.com**

020 8452 0161

Visit our shop at:
40-42 Cricklewood Broadway
London NW2 3ET

EPE IS PLEASED TO BE ABLE TO OFFER YOU THESE

ELECTRONICS CD-ROMS FLOWCODE 5

Complex electronic systems in minutes

New features include:

- C code views and customisation
- Simulation improvements
- Search and replace
- New variable types
- Project auto-documentation
- Project explorer
- Bookmarks
- Improved chip interrupt features
- Compilation errors and warning
- Interrupts overhaul

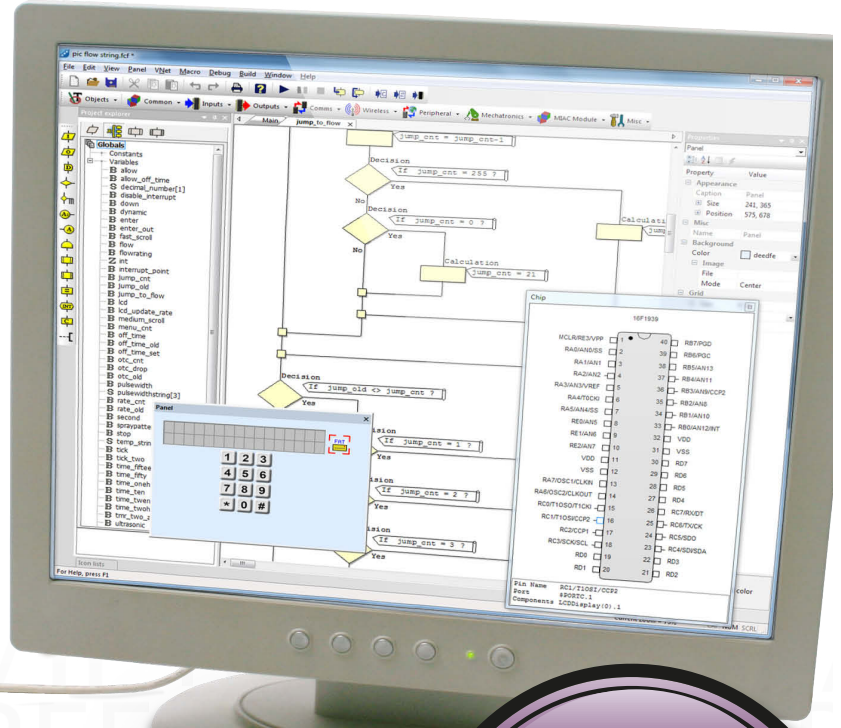

**NEW
OUT
NOW**

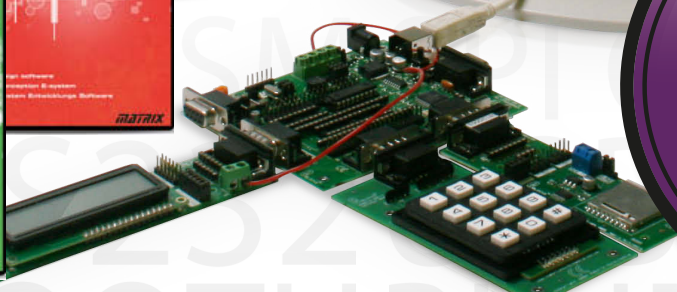

**Flowcode
PICmicro V5
is now available
as a
download**

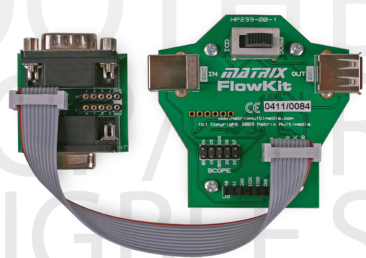

The FlowKit can be connected to hardware systems to provide a real time debug facility where it is possible to step through the Flowcode program on the PC and step through the program in the hardware at the same time. The FlowKit can be connected to your own hardware to provide In-Circuit Debug to your finished designs.

PRICES Prices for each of the CD-ROMs above are:
(Order form on third page)

(UK and EU customers add VAT to 'plus VAT' prices)

Hobbyist/Student
Professional (Schools/HE/FE/Industry)
Flowkit

Flowcode 5

PICMICRO/AVR/DSPIC/PIC24 & ARM Download only

£58.80 inc. VAT
£199.00 plus VAT
£64.90 plus VAT

Please note: Due to popular demand, Flowcode PICmicro, AVR, DSPIC, PIC24 & ARM V5 are now available as a download. Please include your email address and a username (of your choice) on your order. A unique download code will then be emailed to you. If you require the CDROM as a back-up then please add an extra £14 to the above price.

PICmicro TUTORIALS AND PROGRAMMING

HARDWARE

VERSION 3 PICmicro MCU development board

Suitable for use with the three software packages listed below.

This flexible development board allows students to learn both how to program PICmicro microcontrollers as well as program a range of 8, 18, 28 and 40-pin devices from the 12, 16 and 18 series PICmicro ranges. For experienced programmers all programming software is included in the PPP utility that comes with the development board. For those who want to learn, choose one or all of the packages below to use with the Development Board.

- Makes it easier to develop PICmicro projects
- Supports low cost Flash-programmable PICmicro devices
- Fully featured integrated displays – 16 individual LEDs, quad 7-segment display and alphanumeric LCD display
- Supports PICmicro microcontrollers with A/D converters
- Fully protected expansion bus for project work
- USB programmable
- Can be powered by USB (no power supply required)

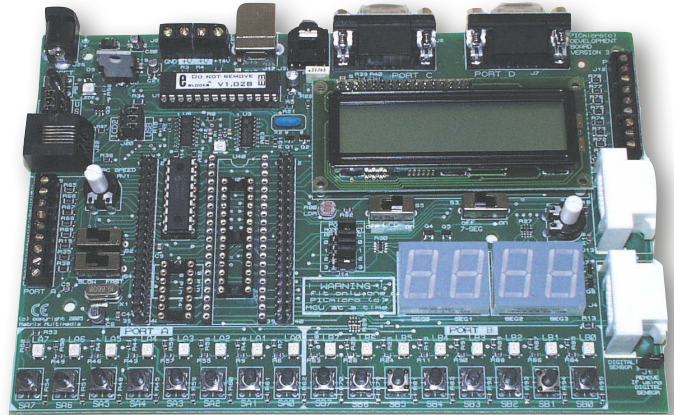

This board is being upgraded, therefore, it is currently unavailable.

£161 including VAT and postage, supplied with USB cable and programming software

SOFTWARE

ASSEMBLY FOR PICmicro V4

(Formerly PICtutor)

Assembly for PICmicro microcontrollers V3.0 (previously known as PICtutor) by John Becker contains a complete course in programming the PIC16F84 PICmicro microcontroller from Arizona Microchip. It starts with fundamental concepts and extends up to complex programs including watchdog timers, interrupts and sleep modes.

The CD makes use of the latest simulation techniques which provide a superb tool for learning: the Virtual PICmicro microcontroller, this is a simulation tool that allows users to write and execute MPASM assembler code for the PIC16F84 microcontroller on-screen. Using this you can actually see what happens inside the PICmicro MCU as each instruction is executed, which enhances understanding.

- Comprehensive instruction through 45 tutorial sections
- Includes Vlab, a Virtual PICmicro microcontroller: a fully functioning simulator
- Tests, exercises and projects covering a wide range of PICmicro MCU applications
- Includes MPLAB assembler
- Visual representation of a PICmicro showing architecture and functions
- Expert system for code entry helps first time users
- Shows data flow and fetch execute cycle and has challenges (washing machine, lift, crossroads etc.)
- Imports MPASM files.

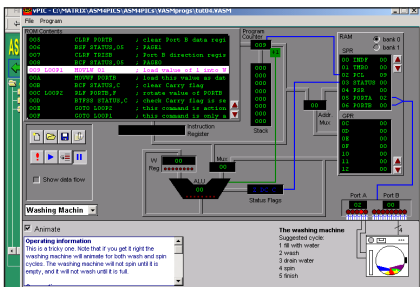

'C' FOR 16 Series PICmicro Version 4

The C for PICmicro microcontrollers CD-ROM is designed for students and professionals who need to learn how to program embedded microcontrollers in C. The CD-ROM contains a course as well as all the software tools needed to create Hex code for a wide range of PICmicro devices – including a full C compiler for a wide range of PICmicro devices.

Although the course focuses on the use of the PICmicro microcontrollers, this CD-ROM will provide a good grounding in C programming for any microcontroller.

- Complete course in C as well as C programming for PICmicro microcontrollers
- Highly interactive course
- Virtual C PICmicro improves understanding
- Includes a C compiler for a wide range of PICmicro devices
- Includes full Integrated Development Environment
- Includes MPLAB software
- Compatible with most PICmicro programmers
- Includes a compiler for all the PICmicro devices.

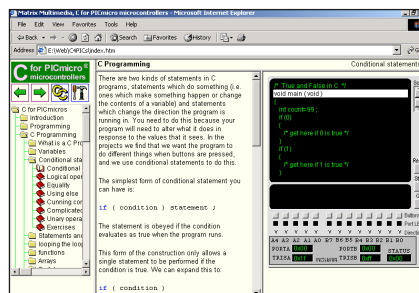

Minimum system requirements for these items: Pentium PC running, 2000, ME, XP; CD-ROM drive; 64MB RAM; 10MB hard disk space.
Flowcode will run on XP or later operating systems

FLOWCODE FOR PICmicro V5 (see opposite page)

Flowcode is a very high level language programming system based on flowcharts. Flowcode allows you to design and simulate complex systems in a matter of minutes. A powerful language that uses macros to facilitate the control of devices like 7-segment displays, motor controllers and LCDs. The use of macros allows you to control these devices without getting bogged down in understanding the programming. When used in conjunction with the Version 3 development board this provides a seamless solution that allows you to program chips in minutes.

- Requires no programming experience
- Allows complex PICmicro applications to be designed quickly
- Uses international standard flow chart symbols
- Full on-screen simulation allows debugging and speeds up the development process.
- Facilitates learning via a full suite of demonstration tutorials
- Produces ASM code for a range of 18, 28 and 40-pin devices
- 16-bit arithmetic strings and string manipulation
- Pulse width modulation
- I2C.

Features include panel creator, in circuit debug, virtual networks, C code customisation, floating point and new components. The Hobbyist/Student version is limited to 4K of code (8K on 18F devices)

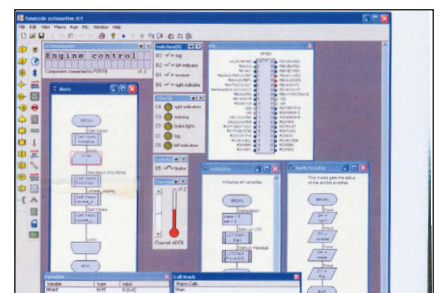

PRICES

Prices for each of the CD-ROMs above are:
(Order form on next page)

(UK and EU customers add VAT to 'plus VAT' prices)

Hobbyist/Student	£58.80	inc VAT
Professional (Schools/HE/FE/Industry)	£150	plus VAT
Professional 10 user (Network Licence)	£499	plus VAT
Site Licence	£999	plus VAT
Flowcode Professional (Schools/HE/FE/Industry) ..	£199	plus VAT
Flowcode 10 user (Network Licence)	£599	plus VAT
Flowcode Site Licence	£999	plus VAT

CIRCUIT WIZARD

Circuit Wizard is a revolutionary new software system that combines circuit design, PCB design, simulation and CAD/CAM manufacture in one complete package.

Two versions are available, Standard or Professional.

By integrating the entire design process, Circuit Wizard provides you with all the tools necessary to produce an electronics project from start to finish – even including on-screen testing of the PCB prior to construction!

- * Circuit diagram design with component library (500 components Standard, 1500 components Professional)
- * Virtual instruments (4 Standard, 7 Professional)
- * On-screen animation
- * Interactive circuit diagram simulation
- * True analogue/digital simulation
- * Simulation of component destruction
- * PCB Layout
- * Interactive PCB layout simulation
- * Automatic PCB routing
- * Gerber export
- * Multi-level zoom (25% to 1000%)
- * Multiple undo and redo
- * Copy and paste to other software
- * Multiple document support

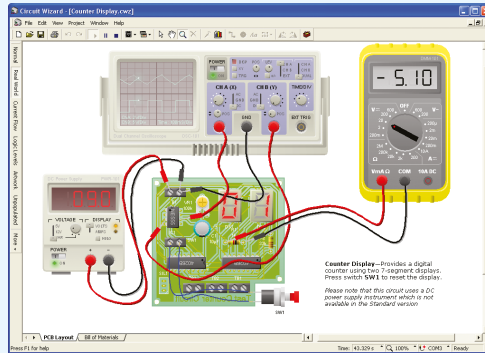

This software can be used with the **Jump Start and Teach-In 2011 series** (and the **Teach-In 4 book**).

Standard **£61.25** inc. VAT
Professional **£91.90** inc. VAT

Minimum system requirements for these CD-ROMs: Pentium PC, CD-ROM drive, 32MB RAM, 10MB hard disk space. Windows 2000/ME/XP, mouse, sound card, web browser.

EPE PIC RESOURCES V2

Version 2 includes the EPE PIC Tutorial V2 series of Supplements (EPE April, May, June 2003)

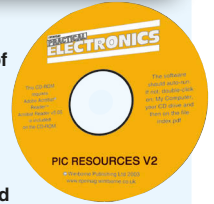

The CD-ROM contains the following Tutorial-related software and texts:

- EPE PIC Tutorial V2 complete series of articles plus demonstration software, John Becker, April, May, June '03
- PIC Toolkit Mk3 (TK3 hardware construction details), John Becker, Oct '01
- PIC Toolkit TK3 for Windows (software details), John Becker, Nov '01

Plus 18 useful texts to help YOU get the most out of your PIC programming.

Price **£14.75** inc. VAT

ELECTRONIC COMPONENTS PHOTOS

A high quality selection of over 200 jpg images of electronic components. This selection of high resolution photos can be used to enhance projects and presentations or to help with training and educational material. They are royalty free for use in commercial or personal printed projects, and can also be used royalty free in books, catalogues, magazine articles as well as worldwide web pages (subject to restrictions – see licence for full details).



Now contains Irfan View image software for Windows, with quick-start notes included.

Price **£19.95** inc. VAT

Please send me: CD-ROM ORDER FORM

- Assembly for PICmicro V4
- 'C' for 16 Series PICmicro V4
- Flowcode for PICmicro V5 (DOWNLOAD + CDROM)
- Flowcode for PICmicro V5 (DOWNLOAD ONLY)
- Flowcode for AVR V5 (DOWNLOAD + CDROM)
- Flowcode for AVR V5 (DOWNLOAD ONLY)
- Flowcode for ARM V5 (DOWNLOAD + CDROM)
- Flowcode for ARM V5 (DOWNLOAD ONLY)
- Flowcode for dsPIC V5 (DOWNLOAD + CDROM)
- Flowcode for dsPIC V5 (DOWNLOAD ONLY)
- Flowcode for PIC24 V5 (DOWNLOAD + CDROM)
- Flowcode for PIC24 V5 (DOWNLOAD ONLY)
- Flowkit



Version required:

- Hobbyist/Student
- Professional
- Professional 10 user
- Site licence

Email:

Username:

Note: The software on each version is the same, only the licence for use varies.

- PICmicro Development Board V4 (hardware) – currently unavailable.

- Circuit Wizard – Standard
- Circuit Wizard – Professional
- EPE PIC Resources V2
- Electronic Components Photos

Full name:

Address:

..... Post code: Tel. No:

Signature:

I enclose cheque/PO in £ sterling payable to WIMBORNE PUBLISHING LTD for £

Please charge my Visa/Mastercard/Maestro: £

Valid From: Card expiry date:

Card No: Maestro Issue No.

Card Security Code (The last 3 digits on or just under the signature strip)

ORDERING ALL PRICES INCLUDE UK POSTAGE

Student/Single User/Standard/Hobbyist Version price includes postage to most countries in the world
EU residents outside the UK add £5 for airmail postage per order

Professional, Multiple User and Site License Versions – overseas readers add £5 to the basic price of each order for airmail postage (do not add VAT unless you live in an EU (European Union) country, then add VAT at 20% or provide your official VAT registration number).

Send your order to:
Direct Book Service
Wimborne Publishing Ltd
113 Lynwood Drive, Merley, Wimborne,
Dorset BH21 1UU

To order by phone ring
01202 880299. Fax: 01202 843233

Goods are normally sent within seven days

E-mail: orders@wimborne.co.uk

Online shop:

www.epemag.com

NET WORK

by Alan Winstanley

YouView, iPlayer



REGULAR readers will know of my earlier affinity with the Humax HDR-Fox T2 digital TV box, a twin-tuner Freeview high-definition hard disk recorder with networking built in that allows users to access several online services, including BBC iPlayer and Youtube on TV. Over Ethernet or Wi-Fi, it can also access media stored on a local network server, such as the Synology DS211J sat on my desk. As an HD Freeview recorder upgrade for an older analogue TV, it's a great choice.

There was a time when all TV viewing had to be planned a week in advance, laboriously setting the VCR (if you were lucky enough to own one) to tape any programmes that clashed with your viewing schedule. Life rotated around a pile of VHS tape cassettes and recordings were often wrongly programmed due to the complexities of VCRs. Today with both Britain's mainstream TV and satellite channels broadcasting on the Internet as well, TV programmes from the last seven days or more can be 'caught up' by viewing them online on a variety of devices or games consoles. Videos can also be downloaded on demand thanks to Netflix or Sky Movies.

Recently, my Humax TV portal services – the recorder's front-end that connects to a network – silently updated itself with an array of 'apps'. I found that I could play around a little by logging into www.myHumax.net on a PC and tying my Humax recorder to a personal web page. However, the paltry choice of compatible online services was unchanged, including Teletext Holidays, Flickr and Google Picasa photo sharing. If I'd hoped to (at last) watch non-BBC channels online, I'd be disappointed as there was still no sign of the promised access to catch-up TV or Sky Player.

Apps for the predictable Twitter and Facebook social sites recently appeared in my Humax web page, but could not be added to the Humax set-top box – and without a decent keyboard would probably be unrewarding to use anyway. The clunky website also alludes to TV programme guides and scheduling recordings on one's designated device, hinting of being able to set up a recording remotely in the future.

YouView

If you are in the market for viewing catch-up TV or video on demand, without using a personal computer, then some interesting hardware choices are available. Humax has been active in the launch of YouView (www.youview.com), a joint venture between broadband suppliers and TV broadcasters that offers video-on-demand TV and catch-up TV over the Internet. YouView boxes can be bought as part of a broadband package or purchased outright. For example, the Humax

DTR-T1000 YouView Digital TV Recorder is based on the now familiar HDR-Fox T2 styling and is readily available online.

It's important to note that it is not Wi-Fi compatible though, so connection to the router by Ethernet cable or Homeplug-type devices is necessary. Reviews are somewhat mixed, perhaps because in principle home networking is not 100% reliable (see later!). At the time of writing, revised models from Humax are in the pipeline, so watch out for the DTR-T1010 with new styling and a 1TB disk. Information on the new model is scarce, but there is no mention of Wi-Fi connectivity again. A new YouView app for iPhones points towards scheduling recordings on a Humax while you're on the go.

Alternatively, consider a 'Smart TV' with Wi-Fi Internet connectivity built in. The choice is more bewildering than ever, but Samsung's Smart TV range from www.samsung.com/uk/consumer/tv-audio-video/television/viewall stands out. Samsung's range of apps include Netflix, Lovefilm, Skype, Twitter and more; a Bluetooth keyboard and Skype camera are sold separately. Other makes to check out include Panasonic's SmartVIERA Internet-connected TV and Sony's Internet TV.

With such an exciting range of home networking equipment becoming readily available, there's never been a better time to consider upgrading your home entertainment system to take advantage of the latest in Internet-delivered entertainment.

More Wi-Fi woes

At the end of last year I added another desktop PC to my home network and, because Ethernet cable was not an option, I naturally chose wireless networking instead. So I dropped in a 54g PCI wireless adapter from my box of bits, with a Wi-Fi antenna on a heavy metal base extending to the desk

for better reception. Thanks to a plug-in Billion 3100SN Access Point (AP) intended to extend coverage around the property, wireless access was fine enough to start with. However, I found that the PC would disconnect from my Wi-Fi intermittently, creating one of those exasperating networking problems that escalated out of all proportion, and (worse) producing murmurs of discontent from the household as well!

Various adapter drivers were downloaded without improvement, including the final version from the maker's website. Annoyingly, it's sometimes necessary to remove the wireless card from the PC again to check its type or hardware version; a useful tip is to note down the MAC addresses of all such wireless gear in a Word file (or in Microsoft One Note) for future reference or network Wi-Fi troubleshooting. It's now the first thing I do when I open the box.



The Humax DTR-T1010 is a new style YouView hard disk recorder for accessing on-demand and catch-up TV. Connection is via Ethernet cable only

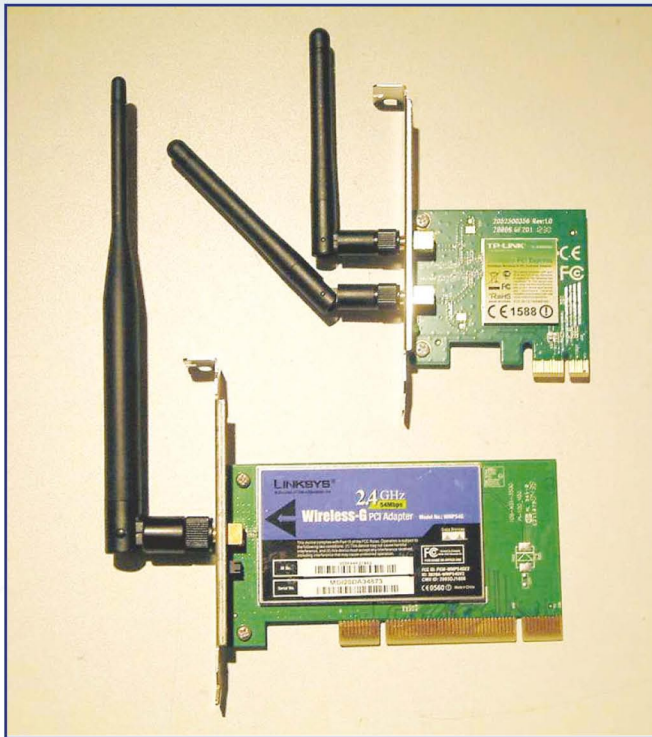

Bottom, a classic PCI wireless -g Wi-Fi card, top; a faster PCI-e 802.11n MIMO card with twin antennae. Note the different PCB edge contact patterns.

Wild goose chase

I find that Windows usually does a decent job of managing wireless network connectivity. If problems are found (continuous disconnections, failing to connect, intermittent dropping out) then you can try installing the wireless adaptor's own software, and disable Windows' control of it to see if that makes a difference. Some software applets are clunky and intrusive, but may work better than Windows' own drivers – it's worth a try. Check websites for later drivers too, and as a last resort it might be worth trying the adapter chipset manufacturer's driver (if known) as well. Free InSSIDer software from MetaGeek is also invaluable for monitoring local wireless activity.

Apart from a PCI card, a legacy USB 54g dongle was also tried without much success, which involved a further wild goose chase online in search of drivers. I gave up after several hours: regardless of what wireless adaptor was used, the PC would disconnect sporadically, but further tests showed that it had taken to disconnecting after exactly an hour.

Wireless adaptors may have a power-saving function that disconnects them periodically, which can cause network outages. To disable this feature, go to Windows Device Manager and expand the Network Adaptors menu. Right-click on the wireless adaptor's name and Advanced Settings will usually contain a Power Saving entry, or sometimes there may be a separate power management tab where power saving can be disabled. Unfortunately, despite the promising-looking implications, disabling power in my case made no difference to the intermittent connectivity.

As a final resort, a new 802.11n wireless card with twin MIMO antennae was installed in the PC's only available PCI-e slot. The high-speed card started up straight away and reception proved excellent, but annoyingly wireless access still dropped after an hour. In any event, a new 802.11n card may be a worthwhile upgrade for many wireless PCs working with modern routers, providing a spare slot is available. PCI-e adapters are cheap (typically £15) and apart from being faster and more sensitive, may be compatible with later wireless security standards than many legacy devices. It is simple to upgrade and PCI-e slots are very small in comparison with PCI slots, see photos.

Faultfinding

Like faultfinding one's latest electronic project, debugging network problems starts by trying to reproduce the fault

consistently, checking one factor at a time and eliminating possible causes methodically. I had already eliminated the wireless adaptor as the cause. As mentioned earlier, it was noted that the drop-out occurred after one hour, or 3600 seconds after powering up the PC – which is exactly the default period for Group Key Renewal set in the router and the range extender. Disappointingly, increasing that period in the router to 24 hours made no difference, and the range extender's value could not be increased beyond a few hours anyway.

I then noticed that when I turned the Billion Bipac 3100SN off, the troublesome PC connected straight away to the router instead, without interruption! To confirm this, I wanted to ping the router from the PC – in Windows, go Start/Run.../cmd then type ping [the router's IP address]. Then, powering up the range extender again caused the connection to drop immediately, and there it stayed, with the moribund PC stuck trying to acquire a network IP address. Even an IP radio behaved the same way.

With this clue I could then focus on the fact that IP addresses were not being issued to clients on the wireless network. That job is usually handled by the router if Dynamic Host Configuration Protocol (DHCP) is enabled, otherwise fixed IP addresses must be configured manually (when those individual MAC addresses are also keyed in).

There was no evidence of any wireless failure or wireless restart in the Billion 7800SN router's system log, so attention turned to the Bipac 3100SN access point instead. This had been configured as a simple plug-in wireless repeater in 'lazy mode' to improve Wi-Fi coverage around the property (see December 2012 *Net Work*), in other words, offering another access point (AP) through which my Wi-Fi devices could connect to the router. My wireless network was using the Wireless Distribution System (WDS) feature to connect to the router, but it seems that WDS has its fair share of compatibility problems, even within the same brand. An alternative method involves using 'Access Point Client' mode to connect to the router in non-WDS mode, as Billion explains on <http://tinyurl.com/cszmpp9>.

The 3100SN setup is accessed using an Ethernet cable with (say) a spare laptop (remembering to set a temporary fixed IP address in the laptop). First, the Wireless Distribution System was disabled and the device was changed to AP-mode instead of wireless repeater. Then my router was selected from the list of wireless access points detected by the 3100SN, and the router's security details were keyed in to complete the connection. At the same time, the AP was given its own SSID (Service Set ID or network name) different from the router's SSID. This would allow me to select either the 3100SN access point or the router, which would help compare results by hooking the PC to different wireless networks if I wanted to.

After changing the setup this way, the wireless PC could now see two wireless SSIDs to connect to: the router and the wireless AP. Recall that previously the stubborn PC could not acquire an IP address when the 3100SN was powered up, but now it connected straight away to the wireless AP. I could also see and connect to the router's much weaker signal. If I wanted to, I could alter the 3100SN SSID back again to match the router's and obtain a seamless-looking Wi-Fi coverage around the property.

With the PC now able to acquire an IP address and connect to the net successfully, the PC was allowed to run continuously, but over many sessions, sure enough, its wireless connectivity would drop after a lengthy period – which is exactly where I came in. It's necessary to 'repair' the connection manually, but a simpler way was simply to hook to the router instead and forget all about it. For my purposes it seems that the non-WDS method is a better way of utilising a wireless range extender – or should I say access point? To this day, I cannot maintain that PC's wireless connectivity any other way!

I hope you enjoyed this month's *Net Work*. Readers can email me at alan@epemag.demon.co.uk or write to the editor at editorial@wimborne.co.uk. Don't forget to keep checking for the latest developments on our new website at: www.epemag.com.

DIRECT BOOK SERVICE

ELECTRONICS TEACH-IN BUNDLE – SPECIAL BUNDLE PRICE £14 FOR PARTS 1, 2 & 3

ELECTRONICS TEACH-IN 2 CD-ROM USING PIC MICROCONTROLLERS A PRACTICAL INTRODUCTION

This *Teach-In* series of articles was originally published in *EPE* in 2008 and, following demand from readers, has now been collected together in the *Electronics Teach-In 2* CD-ROM.

The series is aimed at those using PIC microcontrollers for the first time. Each part of the series includes breadboard layouts to aid understanding and a simple programmer project is provided.

Also included are 29 *PIC N' Mix* articles, also republished from *EPE*. These provide a host of practical programming and interfacing information, mainly for those that have already got to grips with using PIC microcontrollers. An extra four part beginners guide to using the C programming language for PIC microcontrollers is also included.

The CD-ROM also contains all of the software for the *Teach-In 2* series and *PIC N' Mix* articles, plus a range of items from Microchip – the manufacturers of the PIC microcontrollers. The material has been compiled by Wimborne Publishing Ltd. with the assistance of Microchip Technology Inc.

The Microchip items are: MPLAB Integrated Development Environment V8.20; Microchip Advance Parts Selector V2.32; Treelink; Motor Control Solutions; 16-bit Embedded Solutions; 16-bit Tool Solutions; Human Interface Solutions; 8-bit PIC Microcontrollers; PIC24 Microcontrollers; PIC32 Microcontroller Family with USB On-The-Go; dsPIC Digital Signal Controllers.

CD-ROM Order code ET12 CD-ROM £9.50

Book and CD-ROMs

FREE
CD-ROM

ELECTRONICS TEACH-IN 3

The three sections of this book cover a very wide range of subjects that will interest everyone involved in electronics, from hobbyists and students to professionals. The first 80-odd pages of *Teach-In 3* are dedicated to *Circuit Surgery*, the regular *EPE* clinic dealing with readers' queries on various circuit design and application problems – everything from voltage regulation to using SPICE circuit simulation software.

The second section – *Practically Speaking* – covers the practical aspects of electronics construction. Again, a whole range of subjects, from soldering to avoiding problems with static electricity and identifying components, are covered. Finally, our collection of *Ingenuity Unlimited* circuits provides over 40 circuit designs submitted by the readers of *EPE*.

The free cover-mounted CD-ROM is the complete *Electronics Teach-In 1* book, which provides a broad-based introduction to electronics in PDF form, plus interactive quizzes to test your knowledge, TINA circuit simulation software (a limited version – plus a specially written TINA Tutorial), together with simulations of the circuits in the *Teach-In 1* series, plus Flowcode (a limited version) a high level programming system for PIC microcontrollers based on flowcharts.

The *Teach-In 1* series covers everything from Electric Current through to Microprocessors and Microcontrollers and each part includes demonstration circuits to build on breadboards or to simulate on your PC. There is also a MW/LW Radio project in the series. The contents of the book and Free CD-ROM have been reprinted from past issues of *EPE*.

160 pages Order code ET13 £8.50

Bundle Price £14.00

The books listed have been selected by *Everyday Practical Electronics* editorial staff as being of special interest to everyone involved in electronics and computing. They are supplied by mail order direct to your door. Full ordering details are given on the last book page.

FOR A FURTHER SELECTION
OF BOOKS AND CD-ROMS
SEE THE UK SHOP ON OUR
WEBSITE –
www.epemag.com

All prices include UK postage

NEW

ELECTRONICS TEACH-IN 4

FREE
CD-ROM

ELECTRONICS TEACH-IN 4

A Broad-Based Introduction to Electronics plus FREE CD-ROM

The *Teach-In 4* book covers three of the most important electronics units that are currently studied in many schools and colleges. These include, Edexcel BTEC level 2 awards and the electronics units of the new Diploma in Engineering, Level 2.

The Free cover-mounted CD-ROM contains the full Modern Electronics Manual, worth £29.95. The Manual contains over 800 pages of electronics theory, projects, data, assembly instructions and web links.

A package of exceptional value that will appeal to all those interested in learning about electronics or brushing up on their theory, be they hobbyists, students or professionals.

144 pages Order code ET14 £8.99

RADIO

AN INTRODUCTION TO RADIO WAVE PROPOGATION

J.G. Lee

Radio wave propagation is one of the more important discoveries made in the early 20th century. Although technology lagged behind early experimenters pursued this newly discovered phenomenon eagerly for, in understanding the physics of propagation, they were discovering more about our Universe and its workings.

Radio wave propagation has its origins in the world of solar physics. The Sun's radiation provides the mechanism for the formation of the ionosphere. How the ionosphere is formed, and how it provides long-distance communication, is carefully explained. Non-ionospheric propagation, including 'moonbounce' or satellite communications, is covered as well.

This book has been written with the average electronic hobbyist in mind. Technical language and mathematics have been kept to a minimum in order to present a broad, yet clear, picture of the subject. The radio amateur, as well as the short-wave listener, will find explanations of the propagation phenomena which both experience in their pursuit of communications enjoyment.

116 pages Order code BP293 £4.45

PROJECT CONSTRUCTION

IC 555 PROJECTS

E. A. Parr

Every so often a device appears that is so useful that one wonders how life went on before without it. The 555 timer is such a device. Included in this book are over 70 circuit diagrams and descriptions covering basic and general circuits, motor car and model railway circuits, alarms and noise makers as well as a section on 556, 558 and 559 timers. (Note. No construction details are given.) A reference book of invaluable use to all those who have any interest in electronics, be they professional engineers or designers, students or hobbyists.

167 pages Order code BP44 £5.49

HOW TO USE OSCILLOSCOPES AND OTHER TEST EQUIPMENT

R. A. Penfold

This book explains the basic function of an oscilloscope, gives a detailed explanation of all the standard controls, and provides advice on buying. A separate chapter deals with using an oscilloscope for fault finding on linear and logic circuits, plenty of example waveforms help to illustrate the control functions and the effects of various fault conditions. The function and use of various other pieces of test equipment are also covered, including signal generators, logic probes, logic pulser and crystal calibrators.

104 pages Order code BP267 £5.49

ELECTRONIC PROJECT BUILDING FOR BEGINNERS

R. A. Penfold

This book is for complete beginners to electronic project building. It provides a complete introduction to the practical side of this fascinating hobby, including the following topics:

Component identification, and buying the right parts; resistor colour codes, capacitor value markings, etc; advice on buying the right tools for the job; soldering; making easy work of the hard wiring; construction methods, including stripboard, custom printed circuit boards, plain matrix boards, surface mount boards and wire-wrapping; finishing off, and adding panel labels; getting "problem" projects to work, including simple methods of fault-finding.

In fact everything you need to know in order to get started in this absorbing and creative hobby.

135 pages Order code BP392 £5.99

NEW

FREE DOWNLOADS TO PEP-UP AND PROTECT YOUR PC

R. A. Penfold

Bob Penfold, uses his vast knowledge and experience in computing to guide you simply through the process of finding reliable sites and sources of free software that will help optimize the performance and protect your computer against most types of malicious attack.

Among the many topics covered are: Using Windows 7 optimization wizard; PCPitstop for advice on improving performance, reducing start up times, etc; Free optimization scans and the possibility of these being used as a ploy to attack your PC; Free programs such as Ccleaner, Registry checker and PCPal optimization software; Internet speed testing sites and download managers; Overclocking sites, together with warnings about using this technique; Sites and software for diagnosis of hardware faults, including scanning for out of date drivers and finding suitable replacements; Free Antivirus software and programs that combat specific types of malware; Firewalls; Search engines to identify mystery processes listed in Windows Task Manager.

128 pages Order code BP722 £7.99

COMPUTING FOR THE OLDER GENERATION

Jim Gatenby

Among the many practical and useful ideas for using your PC that are covered in this book are: Choosing, setting up and understanding your computer and its main components. Writing letters, leaflets, invitations, etc., and other word processing jobs. Keeping track of your finances using a spreadsheet. Recording details of holidays and other ideas using a database. Using the Internet to find useful information, and email to keep in touch with family and friends. Making 'back-up' copies of your work and checking for viruses. How to use Windows XP to help people with impaired vision, hearing or mobility.

308 pages Order code BP601 £8.99

FOR MORE BOOKS
& CD-ROMS
CHECK OUT
www.epemag.com

THEORY AND REFERENCE

BEBOP TO THE BOOLEAN BOOGIE Second Edition

Clive (call me Max) Maxfield

This book gives the "big picture" of digital electronics. This in-depth, highly readable, guide shows you how electronic devices work and how they're made. You'll discover how transistors operate, how printed circuit boards are fabricated, and what the innards of memory ICs look like. You'll also gain a working knowledge of Boolean Algebra and Karnaugh Maps, and understand what Reed-Muller logic is and how it's used. And there's much, MUCH more. The author's tongue-in-cheek humour makes it a delight to read, but this is a REAL technical book, extremely detailed and accurate.

Contents: Fundamental concepts; Analog versus digital; Conductors and insulators; Voltage, current, resistance, capacitance and inductance; Semiconductors; Primitive logic functions; Binary arithmetic; Boolean algebra; Karnaugh maps; State diagrams, tables and machines; Analog-to-digital and digital-to-analog; Integrated circuits (ICs); Memory ICs; Programmable ICs; Application-specific integrated circuits (ASICs); Circuit boards (PWBs and DWBs); Hybrids; Multichip modules (MCMs); Alternative and future technologies.

470 pages

Order code BEB1 £35.99

BEBOP BYTES BACK (and the Bebop Computer Simulator) CD-ROM

Clive (Max) Maxfield and Alvin Brown

This follow-on to *Bebop to the Boolean Boogie* is a multimedia extravaganza of information about how computers work. It picks up where "Bebop I" left off, guiding you through the fascinating world of computer design... and you'll have a few chuckles, if not belly laughs, along the way. In addition to over 200 megabytes of mega-cool multimedia, the CD-ROM contains a virtual microcomputer, simulating the motherboard and standard computer peripherals in an extremely realistic manner. In addition to a wealth of technical information, myriad nuggets of trivia, and hundreds of carefully drawn illustrations, the CD-ROM contains a set of lab experiments for the virtual microcomputer that let you recreate the experiences of early computer pioneers. If you're the slightest bit interested in the inner workings of computers, then don't dare to miss this!

Over 800 pages in Adobe Acrobat format

CD-ROM

Order code BEB2 CD-ROM £21.95

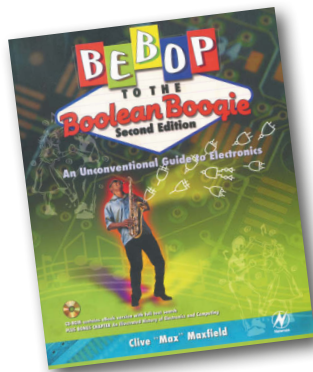

INTERFACING PIC MICROCONTROLLERS Martin Bates

An essential guide to PIC interfacing techniques, using circuit simulation to aid learning.

Explore in detail microcontroller interfacing techniques using the popular PIC 16F877. Work through step-by-step examples interactively using circuit simulation software, supplied as assembly source code.

Interfacing PIC Microcontrollers provides a thorough introduction to interfacing techniques for students, hobbyists and engineers looking to take their knowledge of PIC application development to the next level. Each chapter ends with suggestions for further applications, based on the examples given, and numerous line drawings illustrate application of the hardware.

Step-by-step examples in assembly language are used to illustrate a comprehensive set of interfaces, and these can be run interactively on circuit simulation software, used to aid understanding without the need to build real hardware.

A companion website includes all examples in the text which can be downloaded together with a free version of Proteus's ISIS Lite.

298 pages

Order code NE48 £30.99

GETTING THE MOST FROM YOUR MULTIMETER R. A. Penfold

This book is primarily aimed at beginners and those of limited experience of electronics. Chapter 1 covers the basics of analogue and digital multimeters, discussing the relative merits and the limitations of the two types.

In Chapter 2 various methods of component checking are described, including tests for transistors, thyristors, resistors, capacitors and diodes. Circuit testing is covered in Chapter 3, with subjects such as voltage, current and continuity checks being discussed.

In the main little or no previous knowledge or experience is assumed. Using these simple component and circuit testing techniques the reader should be able to confidently tackle servicing of most electronic projects.

102 pages

Order code BP239 £5.49

PRACTICAL ELECTRONICS HANDBOOK - Fifth Edition. Ian Sinclair

Provides a practical and comprehensive collection of circuits, rules of thumb and design data for professional engineers, students and enthusiasts, and therefore enough background to allow the understanding and development of a range of basic circuits.

Contents: Passive components, Active discrete components, Circuits, Linear I.C.s, Energy conversion components, Digital I.C.s, Microprocessors and microprocessor systems, Transferring digital data, Digital-analogue conversions, Computer aids in electronics, Hardware components and practical work, Micro-controllers and PLCs, Digital broadcasting, Electronic security.

440 pages

Order code NE21 £32.50

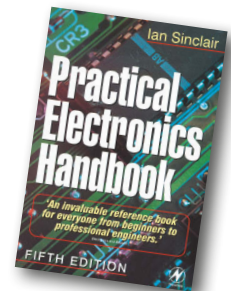

FOR MORE BOOKS
& CD-ROMS
CHECK OUT
www.epemag.com

MUSIC, AUDIO AND VIDEO

QUICK GUIDE TO DIGITAL AUDIO RECORDING Ian Waugh

Covers:

- What computer system you need
- Sound and digital audio essentials
- What to look for in a sound card
- What effects to use
- The art of mixing
- How to burn your music to CD
- How to post your songs on the Web

All modern music recordings use digital audio technology. Now everyone with a computer can produce CD-quality recordings and this book shows you how. Written in a clear and straightforward style, it explains what digital audio recording is, how to use it, the equipment you need, what sort of software is available and how to achieve professional results.

Computer-based recording is the future of music and this book shows how you can join the revolution now.

208 pages

Order code PC121 £7.95

QUICK GUIDE TO MP3 AND DIGITAL MUSIC Ian Waugh

MP3 files, the latest digital music format, have taken the music industry by storm. What are they? Where do you get them? How do you use them? Why have they thrown record companies into a panic? Will they make music easier to buy? And cheaper? Is this the future of music?

All these questions and more are answered in this concise and practical book which explains everything you need to know about MP3s in a simple and easy-to-understand manner. It explains:

How to play MP3s on your computer; How to use MP3s with handheld MP3 players; Where to find MP3s on the Web; How MP3s work; How to tune into Internet radio stations; How to create your own MP3s; How to record your own CDs from MP3 files; Other digital audio music formats.

Temporarily out of print

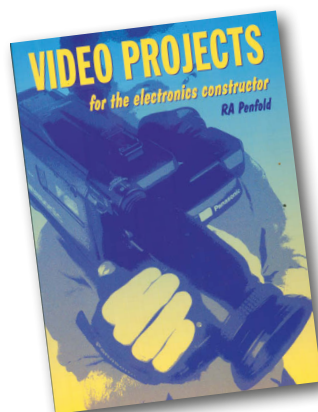

ELECTRONIC PROJECTS FOR VIDEO ENTHUSIASTS R. A. Penfold

This book provides a number of practical designs for video accessories that will help you get the best results from your camcorder and VCR. All the projects use inexpensive components that are readily available, and they are easy to construct. Full construction details are provided, including stripboard layouts and wiring diagrams. Where appropriate, simple setting up procedures are described in detail; no test equipment is needed.

The projects covered in this book include: Four channel audio mixer, Four channel stereo mixer, Dynamic noise limiter (DNL), Automatic audio fader, Video faders, Video wipers, Video crispener, Mains power supply unit.

109 pages

Order code BP356 £5.45

MAKING MUSIC WITH YOUR COMPUTER Stephen Bennett

Nearly everyone with musical aspirations also has a computer. This same computer can double as a high quality recording studio capable of producing professional recordings. This book tells you what software and hardware you will need to get the best results.

You'll learn about recording techniques, software and effects, mixing, mastering and CD production.

Suitable for PC and Mac users, the book is full of tips, "how to do" topics and illustrations. It's the perfect answer to the question "How do I use my computer to produce my own CD?"

92 pages

Order code PC120 £10.95

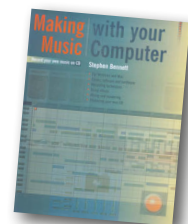

ALL PRICES INCLUDE
UK POST & PACKING

FAULT FINDING, CIRCUITS AND DESIGN

STARTING ELECTRONICS – 4th Edition Keith Brindley

A Starting Electronics is unrivalled as a highly practical introduction for technicians, non-electronic engineers, software engineers, students, and hobbyists. Keith Brindley introduces readers to the functions of the main component types, their uses, and the basic principles of building and designing electronic circuits. Breadboard layouts make this very much a ready-to-run book for the experimenter, and the use of readily available, inexpensive components makes this practical exploration of electronics easily accessible to all levels of engineer and hobbyist.

Other books tell readers what to do, but sometimes fail to explain why – Brindley gives readers hands-on confidence in addition to real scientific knowledge, and insight into the principles as well as the practice. All written explanations and steps are supplemented with numerous photos, charts, tables and graphs. Concepts and practical aspects are explained thoroughly with mathematical formulae and technical schematic drawings.

Each chapter introduces a concept or tool, explains the basic theory, and provides clear instructions for a simple experiment to apply the concept or tool, with quiz sections and answers, at the end of each chapter.

296 pages

Order code NE100 £18.99



HOW ELECTRONIC THINGS WORK – AND WHAT TO DO WHEN THEY DON'T Robert Goodman

You never again have to be flummoxed, flustered or taken for a ride by a piece of electronics equipment. With this fully illustrated, simple-to-use guide, you will get a grasp on the workings of the electronic world that surrounds you – and even learn to make your own repairs.

You don't need any technical experience. This book gives you: Clear explanations of how things work, written in everyday language. Easy-to-follow, illustrated instructions on using test equipment to diagnose problems. Guidelines to help you decide for or against professional repair. Tips on protecting your expensive equipment from lightning and other electrical damage, lubrication and maintenance suggestions.

Covers: colour TVs, VCRs, radios, PCs, CD players, printers, telephones, monitors, camcorders, satellite dishes, and much more!

394 pages

Order code MGH3 £21.99

PIC IN PRACTICE (2nd Edition) David W. Smith

A graded course based around the practical use of the PIC microcontroller through project work. Principles are introduced gradually, through hands-on experience, enabling hobbyists and students to develop their understanding at their own pace. The book can be used at a variety of levels.

Contents: Introduction to the PIC microcontroller; Programming the 16F84 microcontroller; Introductory projects; Headers, porting code – which micro?; Using inputs; Keypad scanning; Program examples; The 16C54 microcontroller; Alphanumeric displays; Analogue to digital conversion; Radio transmitters and receivers; EEPROM data memory; Interrupts; The 12 series 8-pin microcontroller; The 16F87X microcontroller; The 16F62X microcontroller; Projects; Instruction set, files and registers; Appendices; Index.

308 pages

Order code NE39 £24.99

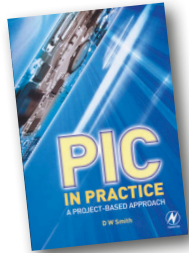

PRACTICAL ELECTRONIC FAULT FINDING AND TROUBLESHOOTING Robin Pain

To be a real fault finder, you must be able to get a feel for what is going on in the circuit you are examining. In this book Robin Pain explains the basic techniques needed to be a fault finder.

Simple circuit examples are used to illustrate principles and concepts fundamental to the process of fault finding. This is not a book of theory, it is a book of practical tips, hints and rules of thumb, all of which will equip the reader to tackle any job. You may be an engineer or technician in search of information and guidance, a college student, a hobbyist building a project from a magazine, or simply a

keen self-taught amateur who is interested in electronic fault finding but finds books on the subject too mathematical or specialised.

The fundamental principles of analogue and digital fault finding are described (although, of course, there is no such thing as a "digital fault" – all faults are by nature analogue). This book is written entirely for a fault finder using only the basic fault-finding equipment: a digital multimeter and an oscilloscope. The treatment is non-mathematical (apart from Ohm's law) and all jargon is strictly avoided.

274 pages

Order code NE22 £41.99

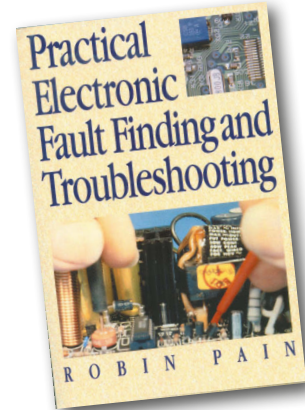

AUDIO AMPS

BUILDING VALVE AMPLIFIERS Morgan Jones

The practical guide to building, modifying, fault-finding and repairing valve amplifiers. A hands-on approach to valve electronics – classic and modern – with a minimum of theory. Planning, fault-finding, and testing are each illustrated by step-by-step examples.

A unique hands-on guide for anyone working with valve (tube in USA) audio equipment – as an electronics experimenter, audiophile or audio engineer.

Particular attention has been paid to answering questions commonly asked by newcomers to the world of the vacuum tube, whether audio enthusiasts tackling their first build, or more experienced amplifier designers seeking to learn the ropes of working with valves. The practical side of this book is reinforced by numerous clear illustrations throughout.

368 pages

Order code NE40 £29.00

VALVE AMPLIFIERS Second Edition. Morgan Jones

This book allows those with a limited knowledge of the field to understand both the theory and practice of valve audio amplifier design, such that they can analyse and modify circuits, and build or restore an amplifier. Design principles and construction techniques are provided so readers can devise and build from scratch, designs that actually work.

The second edition of this popular book builds on its main strength – exploring and illustrating theory with practical applications. Numerous new sections include: output transformer problems; heater regulators; phase splitter analysis; and component technology. In addition to the numerous amplifier and preamplifier circuits, three major new designs are included: a low-noise single-ended LP stage, and a pair of high voltage amplifiers for driving electrostatic transducers directly – one for headphones, one for loudspeakers.

288 pages

Order code NE33 £40.99

BOOK ORDER FORM

Full name:

Address:

.....

.....

..... Post code: Telephone No:

Signature:

I enclose cheque/PO payable to DIRECT BOOK SERVICE for £

Please charge my card £ Card expiry date.....

Card Number Maestro Issue No.....

Valid From Date Card Security Code (the last three digits on or just below the signature strip)

Please send book order codes:

.....

Please continue on separate sheet of paper if necessary

BOOK ORDERING DETAILS

All prices include UK postage. For postage to Europe (air) and the rest of the world (surface) please add £3 per book. For the rest of the world airmail add £4 per book. CD-ROM prices include VAT and/or postage to anywhere in the world. Send a PO, cheque, international money order (£ sterling only) made payable to **Direct Book Service** or card details, Visa, Mastercard, or Maestro to: **DIRECT BOOK SERVICE, WIMBORNE PUBLISHING LIMITED, 113 LYNWOOD DRIVE, MERLEY, WIMBORNE, DORSET BH21 1UU.**

Books are normally sent within seven days of receipt of order, but please allow 28 days for delivery – more for overseas orders. *Please check price and availability (see latest issue of Everyday Practical Electronics) before ordering from old lists.*

For a further selection of books see the next two issues of EPE.
Tel 01202 880299 Fax 01202 843233. E-mail: dbs@wimborne.co.uk
Order from our online UK shop at: www.epemag.com

PCB SERVICE

CHECK US OUT ON THE WEB



Basic printed circuit boards for most recent *EPE* constructional projects are available from the *PCB Service*, see list. These are fabricated in glass fibre, and are drilled and roller tinned, but all holes are a standard size. They are not silk-screened, nor do they have solder resist. Double-sided boards are **NOT plated through hole** and will require 'vias' and some components soldering to both sides. All prices include VAT and postage and packing. Add £2 per board for airmail outside of Europe. Remittances should be sent to **The PCB Service, Everyday Practical Electronics, Wimborne Publishing Ltd., 113 Lynwood Drive, Merley, Wimborne, Dorset BH21 1UU. Tel: 01202 880299; Fax 01202 843233; Email: orders@epemag.wimborne.co.uk. On-line Shop: www.epemag.com.** Cheques should be crossed and made payable to *Everyday Practical Electronics (Payment in £ sterling only)*.

NOTE: While 95% of our boards are held in stock and are dispatched within seven days of receipt of order, please allow a maximum of 28 days for delivery – overseas readers allow extra if ordered by surface mail.

Back numbers or photocopies of articles are available if required – see the Back Issues page for details. WE DO NOT SUPPLY KITS OR COMPONENTS FOR OUR PROJECTS.

Please check price and availability in the latest issue. A large number of older boards are listed on, and can be ordered from, our website.

Boards can only be supplied on a payment with order basis.

PROJECT TITLE	ORDER CODE	COST
MARCH '12		
★ Internet Time Display Module	836	£8.16
Solar-Powered Intruder Alarm	837	£9.33
★ Very, Very Accurate Thermometer/Thermostat	840	£9.33
APRIL '12		
★ Digital Audio Signal Generator		
– Main Board (Jay or Alt)	838	} pair £18.86
– Control/Display Board	839	
EHT Stick	841	£9.15
Capacitor Leakage Adaptor For DMMs	842	£9.72
MAY '12		
High-Performance 12V Stereo Amplifier	843	} pair £15.36
Low-Power Car/Bike USB Charger	844	
★ Solar-Powered Lighting Controller	845	£9.14
Jump Start	846	£7.58
– Plant Pot Moisture Sensor	847	£9.91
– Rain Alarm (Main)	848	£7.97
– Rain Alarm (Sensor)		
JUNE '12		
★ Digital Insulation Meter		
– Main/Display	849	} pair £16.33
– DC-DC Converter	850	
Dual Tracking ±0V to 19V PSU		
– Main PCB	851	£9.33
– Front Panel	852	£8.16
– LCD Meter	853	£7.19
Jump Start Quiz Machine		
– Master	854	£7.39
– Contestant	855	£7.39
JULY '12		
★ 16-Bit Digital Potentiometer	856	£13.99
★ Intelligent 12V Fan Controller	857	£10.10
Jump Start – Battery Voltage Checker	858	£9.14
AUGUST '12		
High Performance Microphone Pre-amplifier	859	£7.58
Jump Start – Solar Powered Charger	860	£7.20
★ Electrolytic Capacitor Reformer And Tester	861	£16.71
★ Ultrasonic Cleaner	862	£8.75
High-power DC Motor Speed Controller		
– Non-Reversible	863	£6.50
– Reversible	864	£6.75
(Both boards double-sided)		
SEPTEMBER '12		
Hearing Loop Receiver	865	£8.55
★ Ultrasonic Anti-Fouling For Boats	866	£9.14
Jump Start – Versatile Theft Alarm	867	£9.33
OCTOBER '12		
S/PDIF To TOSLINK Converter	868	£8.16
TOSLINK to S/PDIF Converter	869	£8.16
★ Digital Lighting Controller		
– Master Board	870	£12.05
– Slave Board	871	£16.72
Jump Start – Crazy Eyes	872	£7.78
– Ghostly Sounds	873	£8.16

PROJECT TITLE	ORDER CODE	COST
NOVEMBER '12		
Hearing Loop Level Meter	874	£9.53
RFID Security System	875	£7.75
Jump Start – Frost Alarm	876	£8.55
DECEMBER '12		
Hot Wire Cutter – Controller	877	£8.55
★ Universal USB Data Logger – Part 1 (double-sided)	878	£16.52
Jump Start – Mini Christmas Lights	879	£10.69
JANUARY '13		
Low-Capacitance Adaptor for DMMs	880	£8.55
★ 3-Input Stereo Audio Switcher		
– Main Board	881	} pair £20.00
– Switch Board	882	
Stereo Compressor – Main Board	883	£12.63
Jump Start – iPod Speaker	884	£8.16
FEBRUARY '13		
10W LED Floodlight	885	£6.75
★ Crystal DAC (double-sided)	886	£18.46
Jump Start – Logic Probe	887	£6.42
MARCH '13		
Lightning Detector	888	£8.75
★ Digital Spirit Level	889	£8.75
★ SemTest – Part 2		
– Main/Lower Board	890	£16.52
– Display/Upper Board	891	£15.55
Interplanetary Voice	892	£8.75
Jump Start – DC Motor Controller	893	£8.55
APRIL '13		
Six-Decade Resistance Substitution Box	894	£10.10
SoftStarter	895	£8.36
Jump Start – Egg Timer	896	£8.36
SemTest HV DC Crowbar	897	£13.61

EPE SOFTWARE

★ All software programs for *EPE* Projects marked with a star, and others previously published can be downloaded free from the Library on our website, accessible via our home page at: www.epemag.com

PCB MASTERS

PCB masters for boards published from the March '06 issue onwards can also be downloaded from our website (www.epemag.com); go to the 'Library' section.

EPE PRINTED CIRCUIT BOARD SERVICE

Order Code	Project	Quantity	Price
.....
Name
Address
.....
Tel. No.
I enclose payment of £..... (cheque/PO in £ sterling only) to:			
Everyday Practical Electronics			
  			
Card No.
Valid From	Expiry Date
Card Security No.	Maestro Issue No.
Signature		
Note: You can also order PCBs by phone, Fax or Email or via the Shop on our website on a secure server:			
http://www.epemag.com			



CLASSIFIED

ADVERTISEMENTS

If you want your advertisements to be seen by the largest readership at the most economical price our classified page offers excellent value. The rate for semi-display space is £10 (+VAT) per centimetre high, with a minimum height of 2.5cm. All semi-display adverts have a width of 5.5cm. The prepaid rate for classified adverts is 40p (+VAT) per word (minimum 12 words).

All cheques, postal orders, etc., to be made payable to Everyday Practical Electronics. **VAT must be added.** Advertisements, together with remittance, should be sent to Everyday Practical Electronics Advertisements, 113 Lynwood Drive, Merley, Wimborne, Dorset, BH21 1UU. Phone: 01202 880299. Fax: 01202 843233. Email: stewart.kearn@wimborne.co.uk. For rates and information on display and classified advertising please contact our Advertisement Manager, Stewart Kearn as above.

BOWOOD ELECTRONICS LTD

Suppliers of Electronic Components

Place a secure order on our website or call our sales line

All major credit cards accepted

Web: www.bowood-electronics.co.uk

Unit 10, Boythorpe Business Park, Dock Walk, Chesterfield, Derbyshire S40 2QR. Sales: 01246 200222

Send 60p stamp for catalogue

CANTERBURY WINDINGS

UK manufacturer of toroidal transformers
(10VA to 3kVA)

All transformers made to order. No design fees.
No minimum order.

www.canterburywindings.co.uk

01227 450810

CAPACITORS WIDE RANGE

including ceramic & polyester
for full info [Visit Section 2](#)

www.partridgeelectronics.co.uk

**ADVERTISE HERE FOR
JUST £25 +VAT CALL
STEWART KEARN
ON 01202 880299
STEWART.KEARN@WIMBORNE.CO.UK**

MISCELLANEOUS

VALVES AND ALLIED COMPONENTS IN STOCK. Phone for free list. Valves, books and magazines wanted. Geoff Davies (Radio), tel. 01788 574774.

KITS, TOOLS, COMPONENTS. S.A.E. Catalogue. SIR-KIT ELECTRONICS, 52 Severn Road, Clacton, CO15 3RB, <http://sir-kit.webs.com>

Everyday Practical Electronics reaches more UK readers than any other UK monthly hobby electronics magazine, our sales figures prove it.

We have been the leading monthly magazine in this market for the last twenty-five years.

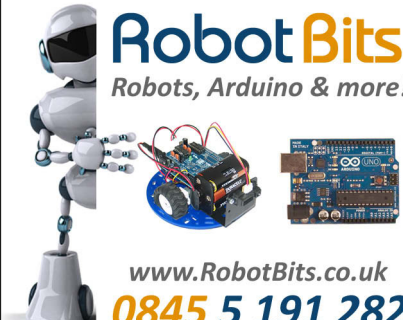

Robot Bits
Robots, Arduino & more!

www.RobotBits.co.uk
0845 5 191 282

BTEC ELECTRONICS TECHNICIAN TRAINING

**NATIONAL ELECTRONICS
VCE ADVANCED ICT
HNC AND HND ELECTRONICS
FOUNDATION DEGREES
NVQ ENGINEERING AND IT
DESIGN AND TECHNOLOGY**

LONDON ELECTRONICS COLLEGE
20 PENYVERN ROAD
EARLS COURT, LONDON SW5 9SU
TEL: (020) 7373 8721
www.lec.org.uk



LOUTH TRANSFORMER COMPANY LIMITED
TEL: 01507 606436 www.louthtxonline.co.uk
FAX: 01507 600168 EMAIL: info@louthtx.com

Transformer Manufacturers 1.0VA - 100KVA

Over 430 types in stock. 1&3 phase.
Design and manufacture to spec.
No minimum order quantities.
Custom designs in 5/7 days.

Enamelled Copper Wire
Over 60 sizes. Grade 1&2 in stock.
0.05mm to 2.5mm diameter.
Small 100g & 275g reels.
Ideal for projects and hobbyists.

Fairfield Ind Est · Louth · Lincolnshire · LN11 0LQ · UK

ADVERTISERS INDEX

BETA LAYOUT	72	QUASAR ELECTRONICS	2/3
COAST ELECTRONICS	51	RK EDUCATION	59
CRICKLEWOOD ELECTRONICS	61	SHERWOOD ELECTRONICS	59
ESR ELECTRONIC COMPONENTS	6	STEWART OF READING	Cover (iii)
JAYCAR ELECTRONICS	4/5		
JPG ELECTRONICS	72		
L-TEK POSCOPE	57	ADVERTISEMENT OFFICES:	
LABCENTER	Cover (iv)	113 LYNWOOD DRIVE, MERLEY, WIMBORNE,	
LASER BUSINESS SYSTEMS	51	DORSET BH21 1UU	
MICROCHIP	Cover (ii)	PHONE: 01202 880299	
MIKROELEKTRONIKA	39	FAX: 01202 843233	
PEAK ELECTRONIC DESIGN	Cover (iii)	EMAIL: stewart.kearn@wimborne.co.uk	
PICO TECHNOLOGY	59	WEB: www.epemag.com	

For editorial address and phone numbers see page 7

Next Month

Content may be subject to change

Electronic Stethoscope

Need to do a bit of self-diagnosis? Make sure your heart is still beating! Maybe you would like to sort out some unusual rattles or other noises in your car's engine or other machinery? This *Electronic Stethoscope* will do the job – and you can listen via headphones or a loudspeaker. It has switchable frequency shaping in four bands, so you can home in on sounds that might otherwise be masked out.



PIC/AVR Programming Adaptor Board

Do you frequently program microcontrollers with a serial programmer? Want to streamline the process so you can quickly do virtually any micro? Well now you can! Our new *Programming Adaptor Board*, in combination with an in-circuit serial programmer (ICSP), allows you to program most 8-bit and 16-bit PIC microcontrollers, as well as 8-bit Atmel AVR's

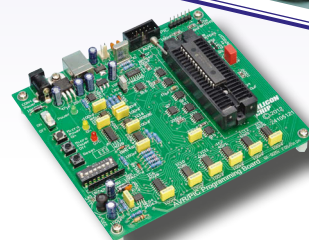

Cheap High-Current Bench Power Supply

If you've ever had to buy a high-current bench supply, you'll know they don't come cheap. But you may well have such a supply sitting unloved and unwanted in the back of a cupboard. It's the power supply in that old computer you never quite got around to throwing away!



Jump Start – Signal Injector

Time for a handy little troubleshooting project; this *Signal Injector* is just what you need to help design and test circuits. A useful and easy project aimed at all levels of experience. This will be Mike and Richard Tooley's thirteenth project in our series dedicated to newcomers, or those following courses taught in schools and colleges.

MAY '13 ISSUE ON SALE 4 APRIL 2013

Rechargeable Batteries With Solder Tags

NIMH		NICAD	
AA 2000mAh	£2.82	AA 650mAh	£1.41
C 4Ah	£4.70	C 2.5Ah	£3.60
D 9Ah	£7.60	D 4Ah	£4.95
PP3 150mAh	£4.95		

Instrument case with edge connector and screw terminals

Size 112mm x 52mm x 105mm tall

This box consists of a cream base with a PCB slot, a cover plate to protect your circuit, a black lid with a 12 way edge connector and 12 screw terminals built in (8mm pitch) and 2 screws to hold the lid on. The cream bases have minor marks from dust and handling price £2.00 + VAT(=£2.35) for a sample or £44.00+VAT (=£51.70) for a box of 44.

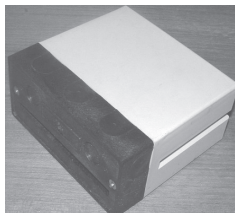
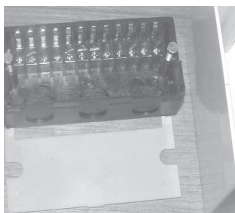

866 battery pack originally intended to be used with an orbitel mobile telephone it contains 10 1.6Ah sub C batteries (42 x 22 dia. the size usually used in cordless screwdrivers etc.) the pack is new and unused and can be broken open quite easily £7.46 + VAT = £8.77



Please add £1.66 + VAT = £1.95 postage & packing per order

JPG Electronics

Shaws Row, Old Road, Chesterfield, S40 2RB.

Tel 01246 211202 Fax 01246 550959

www.JPGElectronics.com

Mastercard/Visa/Switch

Callers welcome 9.30 a.m. to 5.30 p.m. Monday to Saturday



THE ORIGINAL SINCE 1994
PCB-POOL
Beta LAYOUT

FREE Stencil
with every prototype order

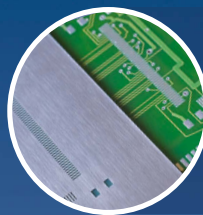

Embedded RFID
authenticate, track & protect
your product



www.magic-pcb.com

Free Phone UK: 0800 389 8560
sales@pcb-pool.com

PCB-POOL® is a registered trademark of

www.pcb-pool.com

Beta
LAYOUT
create:electronics



UK designed,
UK made,
with pride.

Tel. 01298 70012
www.peakelec.co.uk
sales@peakelec.co.uk

Atlas House, 2 Kiln Lane
Harpur Hill Business Park
Buxton, Derbyshire
SK17 9JL, UK

Follow us on twitter
for tips, tricks and
news.
@peakatlas

For insured UK delivery:
Please add £3.00 inc VAT
to the whole order.
Check online or
give us a call for
overseas pricing.

PEAK[®]
electronic design ltd



The new *DCA Pro* ... is now shipping!

As a result of a major product development initiative at Peak Electronic Design Ltd, we are delighted to make this exciting announcement.

£115.95
(£96.62+VAT)

The amazing new *DCA Pro* is now available!

- Just connect your component any way round.
- Graphic display shows detailed component schematics.
- Enhanced component identification, pinout identification and analysis including gain, transconductance, pinch-off, etc.
- USB connectivity for power and communications.
- PC Software included on Peak USB Stick.
- Can be used standalone or with a PC (Win XP or later).
- Curve tracing functions on your PC. (up to $\pm 12V / \pm 12mA$).
- Supports Transistors, MOSFETs, JFETs, IGBTs, Diodes, Zeners, LEDs, Voltage Regulators and much more!
- Free updates online for PC Software and Firmware.
- Uses a single Alkaline AAA battery (and/or USB power).

We aim to despatch your order as soon as possible. Demand for the *DCA Pro* is currently very high and that may cause a small delay. We will contact you immediately to confirm expected despatch date and you can cancel at any time of course.



USB cable included

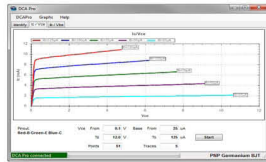

Curve tracing on your PC!

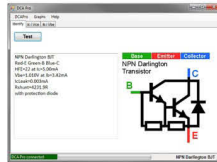

Detailed specs on your PC

It's only possible to show summary specifications here. Please ask if you'd like detailed data. Further information is also available on our website. Product price refunded if you're not happy.

www.stewart-of-reading.co.uk

Check out our website, 1,000's of items in stock.



HP8560E SPECTRUM ANALYSER
30HZ-2.9GHZ with Tracking Generator
£3,500

HP8560 SERIES SPECTRUM ANALYSER Frequency up to 26GHZ
Various Models from £2,500-£7,000



HP83711A/B SYNTHESISED SIGNAL GENERATOR
1-20GHZ Various Options
£4,000-5,000



TEKTRONIX TDS784D
4 Channel 1GHz 4GS/S
Opts 05/1M/2M/2C/3C/4C no Probes
£2,750

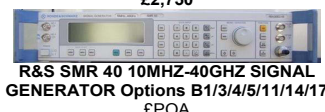

R&S SMR 40 10MHZ-40GHZ SIGNAL GENERATOR Options B1/3/4/5/11/14/17
£POA



RACAL 1792 RECEIVER
£300

AGILENT E4402B Spectrum Analyser
100HZ – 3GHZ with Option 1DN Tracking
Gen; 1 DR Narrow Res; A4H GPIB,
UKB.....£5800
HP 35670A FFT Dynamic Signal Analyser
2 Channel. Unused in original box...£4000
AGILENT 83752B Synthesised Sweeper
0.01-20GHZ.....£6000
HP83711B Synthesised 1-20GHZ with
Opt I/E Attenuator.....£5000
AGILENT/HP E4431B Signal Generator
250KHZ-2GHZ Digital Modulation...£2750
MARCONI 2024 Signal Generator 9KHZ-
2.4GHZ Opt 04.....£1250
MARCONI/IFR 2030 Signal Generator
10KHZ-1.35 GHz.....£995
MARCONI 2022E Synthesised AM/FM
Signal Generator 10KHZ-1.01GHZ...£500
HP8566A Spectrum Analyser 100HZ-
22GHZ.....£1950
HP8568A Spectrum Analyser 100HZ-
1500MHZ.....£1250
AVCOM PSA-37D Spectrum Analyser
1MHZ-4.2GHZ.....£-
IFR 1200S Service Communication
Monitor.....£1500
HP6624A Power Supply 0-20V 0-2A
Twice, 0-7V 0-5A; 0-50V 0.8A
Special price.....£350
AVO/MEGGAR FT6/12 AC/DC
breakdown tester.....£400-£600
MARCONI/IFR/AEROFLEX 2025 Signal
Gen 9KHZ—2.51GHZ Opt 04 High Stab
Opt 11 High Power etc As New.....£2500
SOLARTRON 1250 Frequency Response
Analyser 10uHZ-65KHZ.....£995
HP3324A Synthesised Function
Generator 21MHZ.....£500
HP41800A Active Probe 5HZ-500MHZ
.....£750
ANRITSU MS2601A Spectrum Analyser
10KHZ-2.2GHZ 50ohm.....£750
AGILENT E4421B 250KHZ-3GHZ
Signal Generator.....£2500

HP53131A Universal Counter Opt 001
Unused Boxed 3GHZ.....£850
Unused Boxed 225MHZ.....£595
Used 225MHZ.....£495
HP8569B Spectrum Analyser 0.01-
22GHZ.....£995
HP54616C Oscilloscope Dual Trace
500MHZ 2GS/S Colour.....£1250
QUART LOCK 10A-R Rubidium
Frequency Standard.....£1000
PENDULUM CNT90 Timer/Counter
/Analyser 20GHZ.....£1950
ADVANTEST R3465 Spectrum
Analyser 9KHZ-8GHZ.....£-
HP Programmable Attenuators £300
each
33320H DC-18GHZ 11db
33321G DC-18GHZ 70db
Many others available
AGILENT E3610A Power Supply 0-8v
0-3A/0-15v 0-2A Unused
AGILENT E3611A Power Supply 0-20V
0-1.5A/0-35V 0-0.85V Unused
HP6269B Power Supply 0-40V 0-50A
.....£400
AMPLIFIER RESEARCH Power
Amplifier 1000LAM8.....£POA
MARCONI/IFR 2945/A Radio
Communication Test Sets with options
.....from £3,000
MARCONI 2955/A/B Radio
Communication Test Sets..... from £625
MARCONI/IFR 6200/6200B Microwave
Test Set.....£-
HP33120A Function Generator
100 MicroHZ – 15MHZ Unused Boxed
.....£595
Used, No Moulding, No Handle...£395
ENI 3200L RF Power Amplifier
250KHZ-150MHZ 200W 55Db...£POA
CIRRUS CRL254 Sound Level Meter
with Calibrator.....£95
CEL328 Digital Sound Level Meter with
CEL284/2 Acoustical Calibrator.....

SPECIAL OFFERS

MARCONI 2305 Modulation Meter.£295
MARCONI 6960B Power Meter with
6910 Sensor 10MHZ-20GHZ.....£295
HAMEG 605 Oscilloscope Dual Trace
60MHZ.....£125
BLACK STAR 1325 Counter Timer
1.3GHZ.....£95
HP8484A Power Sensor 0.01-18GHZ
0.3nW-10uW.....£125



ANRITSU 54169A
Scaler Network
Analyser 0.01-
40GHZ £POA

ANRITSU 37247C
Vector Network
Analyser 0.04-
20GHZ £POA

Many Accessories
with each unit

FLUKE SCOPEMETERS 99B Series II
2Ch 100MHZ 5GS/G
..... from £325
97 2Ch 50MHZ 25MS/S..... from £225

STEWART OF READING

17A King Street, Mortimer,
Near Reading RG7 3RS
Telephone: 0118 933 1111
Fax: 0118 933 2375
9am – 5pm Monday – Friday

Used Equipment – **GUARANTEED**
Prices plus Carriage and VAT

Please check availability before
ordering or **CALLING IN**

CAD CONNECTED

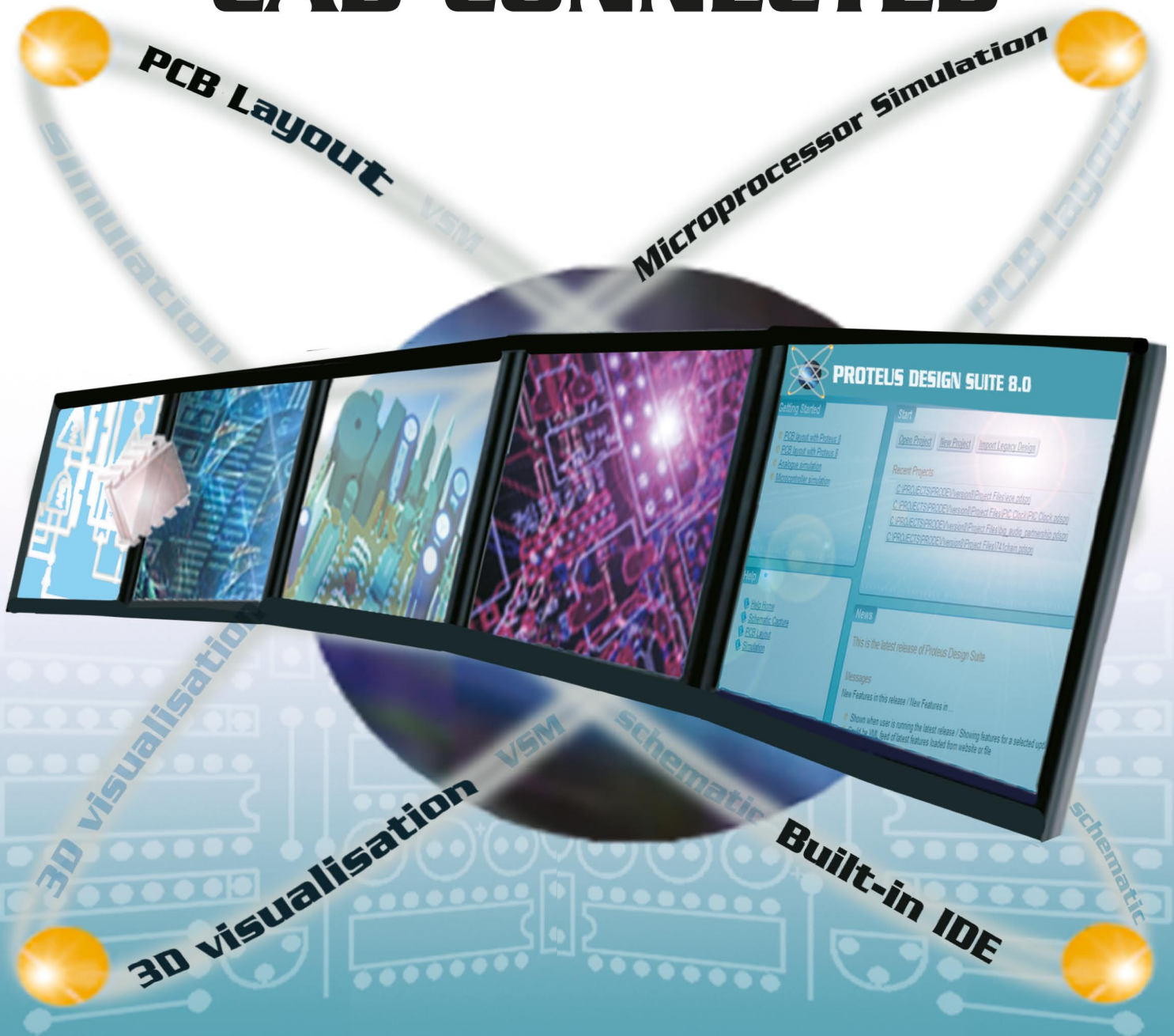

PROTEUS DESIGN SUITE VERSION 8

Featuring a brand new application framework, common parts database, live netlist and 3D visualisation, a built in debugging environment and a WYSIWYG Bill of Materials module, Proteus 8 is our most integrated and easy to use design system ever. Other features include:

- Hardware Accelerated Performance.
- Unique Thru-View™ Board Transparency.
- Over 35k Schematic & PCB library parts.
- Integrated Shape Based Auto-router.
- Flexible Design Rule Management.
- Polygonal and Split Power Plane Support.
- Board Autoplacement & Gateswap Optimiser.
- Direct CAD/CAM, ODB++, IDF & PDF Output.
- Integrated 3D Viewer with 3DS and DXF export.
- Mixed Mode SPICE Simulation Engine.
- Co-Simulation of PIC, AVR, 8051 and ARM MCUs.
- Direct Technical Support at no additional cost.

labcenter  www.labcenter.com
Electronics

Labcenter Electronics Ltd. 21 Hardy Grange, Grassington, North Yorks. BD23 5AJ.
Registered in England 4692454 Tel: +44 (0)1756 753440, Email: info@labcenter.com

Visit our website or
phone 01756 753440
for more details