

DRILL
REGULATIONS

OF THE

UNITED STATES ARMY
AT THE OFFICE OF THE SECRETARY OF WAR

DRILL REGULATIONS

OF THE

Grand Encampment of Knights Templar of the United States of America

Adopted at Seattle, Washington, July 30, 1925



NEWTON, KANSAS

Revised January, 1926

Copyright, 1926, by
The Grand Encampment of Knights Templar
of the United States of America

AUTHORIZATION BY THE GRAND MASTER

Grand Encampment of Knights Templar
of the United States of America

Office of

THE M. E. GRAND MASTER

Denver, Colorado, Jan. 15, 1926.

By the power and authority in me vested as Grand Master of the Grand Encampment of Knights Templar of the United States of America, I hereby approve this final report of the Committee on Drill Regulations, which was adopted by unanimous vote at the Triennial Conclave held at Seattle July 30th, 1925, for the exclusive use of the Grand Encampment and all its constituent and subordinate bodies. It is understood that these drill regulations, while permissible, do not alter or control any manual of asylum ceremonies in any jurisdiction, although their revision to conform with this adopted standard is earnestly recommended.

GEORGE W. VALLERY, Grand Master.

THE KANSAN PRINTING COMPANY
Printers and Publishers
Newton, Kansas

TABLE OF CONTENTS

Authorization by the Grand Master.....	Page	3
Introduction	Page	7
Definitions	Page	9

COMMITTEE:

PERRY M. HOISINGTON, P. G. C.
Newton, Kansas

WM. H. JENNINGS, P. G. C.
Chicago, Illinois

FRANK C. JONES, P. G. C.
Houston, Texas

	Par.
General Principles	1
General Rules for Drills and Formations.....	11
Orders, Commands and Signals.....	34
School of the Knight and Squad.....	45
The Squad	73
Manual of the Sword.....	83
Sword Exercise Ritual.....	116
School of the Officer.....	137
Formation for Public Parade.....	147
The Standard	153
Manual of the Color.....	154
Eminent Commander and Staff.....	156
The Band	157
Escorts of Honor.....	158
Church Parade.....	159
Honors and Salutes.....	160
Official Knight Templar Honors.....	168
Escort of the Color (Standard).....	169
Drill Corps and Competitions.....	170
Competitive Drills	171
Judges	173
Rules for Competitions.....	174
Scoring	176
The Program Plan.....	177
School of the Commandery and Platoon.....	178
The Standard Guard.....	183
The Platoon	184
Movements by Platoons.....	220-252
Movements by Sections.....	234

Commandery Display Movements-----	287
School of the Battalion and Regiment-----	332
The Regiment-----	339
Evolutions of the Battalion-----	348
Evolutions of the Regiment-----	408
The Brigade-----	435
Reviews—	
General Rules-----	436
Commandery Review-----	450
Battalion Review-----	451
Regimental Review-----	452
Parades—	
Commandery Parade-----	453
Battalion Parade-----	454
Regimental Parade-----	455
Street Parade-----	457
Inspections—	
Commandery Inspection-----	458
Battalion Inspection-----	459
Proper Display of the American Flag-----	460
Bugle Signals and Calls-----	461
Alphabetical Index-----	Page 252

DRILL REGULATIONS

of

The Grand Encampment of Knights Templar of the United States of America

INTRODUCTION

The Committee on Drill Regulations of the Grand Encampment was appointed by the Grand Master, pursuant to a resolution adopted at the Triennial Conclave, held in New Orleans, on May 27, 1922. It was the result of the need expressed by many grand commanderies, for a uniform system of drill, in consonance with our uniform ritual; also to afford an authoritative method for the organization of Grand Encampment and Grand Commandery formations; and finally to allay the constantly recurring uncertainty and friction arising in our triennial competitive drills, by reason of many different systems of tactics.

While claiming very little originality, your committee has carefully studied the drill tactics of every grand jurisdiction, as well as the tactics and drill regulations of the United States Army from 1865, and have included in this compilation that which seems most applicable to the purposes, circumstances and traditions of Templardom. Harmony with our Ritual, and an intelligent co-ordination of the movements and nomenclature of the army drill, with the terms used by Knights Templar, has been our constant aim.

Realizing that Templar drill is never a preparation for war, the older form of Upton's close order drill, has been preferred to the more modern U. S. infantry drill regulations, in which special emphasis is placed on training for

combat. However, the infantry drill regulations has been taken as the model in form and arrangement, and wherever possible its exact language and movement has been followed.

Acknowledgment is also made for many ideas and suggestions, gathered from various sources, and especially from the following books of tactics:

Manual of Knights Templar Ceremonies of the Grand Encampment.

Knights Templar Drill Regulations, California.

Templar Drill Regulations, Indiana.

Iowa Knights Templar Tactics.

Manual for Tactics and Drill, Massachusetts and Rhode Island.

Michigan Knights Templar Tactics.

Templar Tactics, Missouri.

Templar Drill and Tactics, New York.

Templar Tactics and Drill, Pennsylvania.

Knights Templar Drill Regulations, Texas.

Templar Tactics and Manual, Chilcott of Maine.

Knights Templar Tactics, South Dakota.

Knights Templar Tactics, Purinton.

Manual and Tactics, Grant.

Tactics and Monitor, Sumner.

Infantry Drill Regulations, U. S. A.

The mechanical drawings were executed by Sir Knight H. Gearing of Los Angeles Commandery No. 9, with suggestions from General Wankowski, P. G. C., and the assistance of the members of that Commandery.

Besides affording the fundamentals of close order drill, an attempt has been made to incorporate the necessary features of display and ceremony, characteristic of Templarism; also while the text is written for the average small commandery, careful provision has been made for its easy adaptation to larger bodies and commanderies and to the formations and ceremonies of grand commanderies; and while not containing movements exclusively used in the asylum ceremonies, frequent reference has been made thereto, and care taken, to avoid conflict therewith.

The preliminary report of the committee in the form

"Provisional Drill Regulations" was widely distributed in all the Grand Jurisdictions, and recommended by the Grand Master for trial that its strength and weakness might thereby be proven. Three editions amounting to about five thousand copies were sold at cost of publication, and numerous changes and modifications made as a result of criticisms and suggestions received. At the triennial conclave at Seattle July 30, 1925, the report was adopted and the committee continued with instructions to make a final revision and publish the work with suitable illustrations, under control of the Grand Encampment, for the use of the Grand Encampment and all of its constituent and subordinate bodies. Copyright has been secured in the title of the Grand Encampment, and the book is accordingly herewith presented under the authorization of the Grand Master. No drill book was ever perfect, or satisfactory to all users, but it is believed this will furnish a basis for harmonious action and further improvement. To this end correspondence is invited from every source and explanations promised to all inquiries to the full ability of the committee.

Address all communications to the committee.

P. M. Hoisington, P. G. C., Newton, Kansas, Chairman.

W. H. Jennings, P. G. C., Chicago, Ill.

Frank C. Jones, P. G. C., Houston, Texas.

DEFINITIONS

About: A wheel or face of 180 degrees (a half circle).

Alignment: A straight line upon which several Knights or Ranks are formed or are to be formed.

Base: The element on which a movement is regulated.

Cadence: The uniform time of step in marching or the succession of movements in the sword manual:

Quick time—120 movements per minute.

Double time—180 movements per minute.

Common time—90 movements per minute.

Sword cadence at a halt executed in quick time.

Sword cadence on the march executed in marching time.

Center: The middle point or element of a command.

- Column:** A formation in which the elements are placed one behind another.
- Commander:** The officer, junior officer or Sir Knight who is actually in command of the lines. The honorary title of the head of the commandery is "Eminent Commander."
- Company:** A subdivision of a commandery; not less than two platoons.
- Company Leader:** An officer or junior officer of any grade, or a Knight, in command of a company (twenty-four files so designated).
- Cover:** To take position exactly in rear of another.
- Deploy:** To extend the front. In general to change from column to line, or from close to extended order.
- Depth:** The space from head to rear of any formation, including the leading and rear elements. The depth of a man is assumed to be 12 inches.
- Distance:** Space between elements in the direction of depth. See Par. 187.
- Division:** A sub-division of a commandery formed for asylum ceremonies (see platoon). A sub-division of the grand parade of the Grand Encampment or of a grand commandery.
- Drill:** The exercises and evolutions taught in the asylum or on the drill field, and executed in the precise and formal manner prescribed.
- Dress:** Alignment to the right or left as in forming a rank.
- Echelon:** Elements placed one behind another, extending beyond and unmasking one another, either wholly or in part.
- Element:** A file, squad, section, platoon, company or larger body, forming a part of a still larger body (see unit).
- Facing Distance:** About 10 inches, i. e., the difference between the front of a Knight in ranks and his depth.
- Field Officer:** Officers of the grade of battalion commander and the commanders of higher units, excepting Marshal (General).
- File:** A Knight in rank. If in double rank includes the corresponding rear rank Knight. A line faced to the right (or left) is called a column of files.

- File Closers:** Officers or junior officers placed in rear of the line whose duty is to rectify mistakes and to command sub-divisions.
- File Leader:** The leading Knight whom the other Knights or files cover.
- Flank:** The right or left of a command in line or in column.
- Formation:** Arrangement of the Knights of a command. The placing of all fractions in their order in line or in column.
- Front:** The space in width occupied by a command or any element. The front of a Knight is 22 inches. Also the general direction toward which the command is moving.
- Guide:** One upon whom the command or Knight regulates the march.
- Guidon:** A small banner displaying the name and number of a commandery or larger organization. See Marker.
- Head:** The leading element of a column.
- Interval:** Space between elements of the same line.
- Junior Officers:** All officers below the rank of Captain General (see officers).
- Left in Front:** A column formed to the left from line, or to the rear from front. See Right in Front.
- Line:** A formation in which the different elements are abreast of each other.
- Marching Flank:** The flank furthest from the pivot in turning or wheeling.
- Marker:** See Guidon.
- Motion:** Distinct movements in the Manual of the Sword.
- Officers:** The Captain General and all officers above that grade, and past commanders. (See Junior Officers.)
- Pace:** Thirty inches; the length of the full step in quick time.
- Pivot:** The Knight on the flank upon which the wheel or turn is made.
- Fixed Pivot**—The Knight on the pivot marks time and turns his body to conform to the front of the unit, gaining no ground during the execution of the movement.
- Moving Pivot**—The Knight on the pivot moves on the arc of a circle the radius of which is 30 inches, and turns his body to conform to the front of the unit.

- Platoon:** A sub-division of a commandery, usually not less than 12 files, formed for drill (see division).
- Platoon Leader:** An officer, or junior officer of any grade, or a Knight, in command of a platoon.
- Ploy:** To diminish front, as to pass from line to column.
- Point of Rest:** The point at which a formation begins.
- Post:** Official position or place of officers or Knights.
- In Quarte:** When the Sword Gripe is held, back of the hand down.
- Rank:** A line of Knights placed side by side, also the grade of an officer.
- Right:** The right extremity or element of a body of Knights. (contra, the left.)
- Right in Front:** A column formed to the right from line. When the right of the line is on the right. A formation when the right of the line is in front. When the guide, in column of threes or sections, is on the left. When the file closers are on the right flank of the column.
- Roster:** A list of officers or Knights for duty. The roll of officers and Knights of a commandery.
- Section:** Two sets of threes abreast, in column or in line.
- Squad:** A small number of Knights for drill.
- Sub-division:** The several parts into which a commandery or larger body is divided, as threes, sections, platoons, etc.
- In Tierce:** When the sword gripe is held, back of the hand up.
- Turn:** A movement placing a rank at right angles to its former position, but executed by the Knights individually in succession.
- Under Arms:** Equipped with accoutrements, with sword drawn or in scabbard.
- Unit:** (See Element.)
- Verify:** To assure the correctness of a formation.
- Wheel:** A circular movement by which a rank is placed at right angles to its former position.
- Wheeling Distance:** A distance between subdivisions in column so that when wheeled into line the subdivisions will exactly join. Equal to the front of the subdivision less the depth of a Knight.
- Wing:** That portion of a commandery, battalion, or larger body, from the center to the flank.

GENERAL PRINCIPLES

1. A careful preliminary study of general principles should always be made by officers and junior officers, before attempting drill or instruction. The Eminent Commander is the commanding officer and is responsible for the proper training of the commandery.

2. It is not expected, however, that the Eminent Commander will actually be in command of every activity of the commandery at all times. If he does not wish to assume the command, he will direct the Generalissimo, Captain General, or other competent Sir Knight, to act as the military officer, under the title of "Commander," the subordinate in such case to remember that he is always under the command and direction of the Eminent Commander. In accordance with templar tradition and custom, this officer will often, perhaps generally, be the Captain General. In large commanderies there is no objection to the appointment also of an Adjutant or Executive Officer, "Chief of Staff." These appointments are generally permanent, but may be emergent, and are always at the pleasure and discretion of the Eminent Commander.

3. Drills executed at attention and the ceremonies are designed to teach precise and knightly movement, and to inculcate that prompt obedience which is essential to proper knightly control. To this end, smartness and precision should be exacted in the execution of every detail. Such drills should be frequent, but short.

4. The formations, movements, honors and ceremonies of these drill regulations are made to conform to the infantry drill of the United States army, of present and earlier standard, as nearly as possible, consistent with the purpose, tradition, uniform and arms of Templarism.

5. To harmonize Knights Templar official titles with military terms, the following rules will be observed; it being understood, that for drill and instruction, the commanding officer may always make substitute appointments, required for efficiency, which appointments shall not affect the templar rank of any officer.

6. The Eminent Commander, referred to as "Commander," will command, and the Generalissimo and Captain General will be second and third in command. When, therefore, the commandery is formed as a single unit (company) they will simulate respectively the positions of captain, first lieutenant and second lieutenant (officers), the remaining officers of the commandery, classified as junior officers (non-commissioned officers), in order of rank, will correspond to the sergeants of a military company.

7. When the Commandery is formed as a battalion the constructive rank of the Commander will be that of major; if as a regiment, that of colonel, with corresponding increase in the rank of his subordinates.

8. Grand Encampment and Grand Commandery officers will respectively simulate the grades above commandery officers, as indicated in the U. S. tables of organization, for the battalion, regiment or higher unit. The duties of officers and staffs will conform as nearly as may be with the same tables. The title of the commanding officer of a Templar brigade will be "Brigade Commander"; and of larger bodies "Marshal" or "Grand Marshal" instead of "General."

9. While in these regulations Templar rather than military terms are used, no objection is seen to the employment of military titles for drill officers, especially of the higher units, as is now the practice in some jurisdictions, providing such course shall be approved by the grand commandery.

Since we have so few mounted commanderies, no provision has been made for such drill, those interested being referred to the U. S. cavalry drill regulations.

10. The ranking officer of the Commandery, Grand Commandery or Grand Encampment may detail or relieve acting officers or junior officers, and form or discharge any required staff, whenever he deems it expedient or necessary, for drill formations, but the assumption of military authority by such officers shall not confer or deny Templar rank. Past Commanders are designated as officers. Guides of threes or sections (corporals) are usually designated from the number of well drilled Knights. Acting junior officers may be similarly designated.

GENERAL RULES FOR DRILLS AND FORMATIONS

10a. Since Knights Templar drill is never professional, and as a means of simplicity, and an assistance to preparation and judging in contests, these Regulations in general provide but one way for the execution of each movement. While great latitude is permitted in the instruction and maneuver of individual commanderies, in all competitions and in ceremonies, the text must be strictly followed, expedients being permissible only in cases not covered by the text, and in competitions subject always to the interpretation of the judges. General Rules will always be followed unless otherwise provided, and in any variation between description and illustration the description will govern.

11. Formations are based upon a front of three Knights as a unit.

All movements are described for single rank, but unless otherwise specified, the same orders and movements may be applied to double rank, at the option of the commanding officer, by such commands and means as he may desire.

NOTE—Double rank for templar formations is discouraged for the following reasons: By tradition Knights Templars were always mounted, and cavalry or dragoons are never formed in double rank, mounted or on foot; with the close elbow touch prescribed by these regulations, the distance—ten inches—between the front and rear rank, would practically prevent the execution of the sword manual by the rear rank; the drifting sidewise movement of the rear rank necessary in the wheelings, is awkward and unsightly, and the formation is wholly unsuited to the asylum ceremonies. If space is limited it is always preferable to form subdivisions separately, and close in mass, as the need for congestion may require. See Formation of the Commandery, Par. 189.

12. When the preparatory command consists of more than one part, its elements are arranged as follows:

(1) For movements to be executed successively by the subdivisions or elements of a command: (a) Description of the movements; (b) how executed, or on what element executed.

(2) For movements to be executed simultaneously by the subdivisions of a command: (a) the designation of the subdivisions; (b) the movement to be executed.

13. Movements that may be executed toward either flank are explained as toward but one flank, it being necessary to substitute the word "left" for "right," and to reverse, to have the explanation of the corresponding movement toward the other flank. The commands are given for the execution of movements toward either flank. The substitute word of the command is placed within parentheses.

14. Any movement may be executed either from the halt or when marching, unless otherwise prescribed. If at a halt, the command for movements involving marching need not be prefaced by **FORWARD**, as 1. **Column right (left)**, 2. **MARCH**.

15. Any movement not specially excepted may be executed in double time.

If at a halt, or if marching in quick time, the command **Double Time** precedes the command of execution.

16. In successive movements executed in double time the leading or base unit marches in quick time when not otherwise prescribed; the other units march in double time to their places in the formation ordered and then conform to the gait of the leading or base unit.

If marching in double time, the command **Double Time** is omitted. The leading or base unit marches in quick time; the other units continue at double time to their places in the formation ordered and then conform to the gait of the leading or base unit.

17. To hasten the execution of a movement begun in quick time, the command: 1. **Double time**, 2. **MARCH**, is given. The leading or base unit continues to march in quick time, or remains at halt if already halted; the other units

complete the execution of the movement in double time and then conform to the gait of the leading or base unit.

18. To stay the execution of a movement when marching, for the correction of errors, the command: 1. **In place**, 2. **HALT**, is given. All halt and stand fast, without changing the position. To resume the movement the command: 1. **Resume**, 2. **MARCH**, is given.

19. To revoke a preparatory command, or, being at a halt, to begin anew a movement improperly begun, the command **AS YOU WERE**, is given, at which the movement ceases and the former position is resumed.

20. Unless otherwise announced, the guide of a platoon or larger subdivision of a commandery, or of a commandery in line, is right; of a commandery in line of subdivisions, center; of a rank in column of threes or sections, toward the side of the guide of the commandery.

To march with guide other than as prescribed above, or to change the guide: **Guide right (left or center)**.

In successive formations into line, the guide is toward the point of rest; in platoons or larger subdivisions it is so announced.

The announcement of the guide, when given in connection with a movement, follows the command of execution for that movement; as, 1. **Forward**, 2. **MARCH**, 3. **Guide right (left)**, unless otherwise specified.

21. The wheel on the fixed pivot by subdivisions is used in all formations from line into column and the reverse.

The wheel on the moving pivot is used by subdivisions of a column in executing changes of direction.

The moving pivot will describe a circle the radius of which is 30 inches; the step of about nine inches required in column of threes will be reduced proportionately as the front of the subdivision is increased, the radius being always the same.

22. Partial changes of direction may be executed by interpolating in the preparatory command the word **half** as

column half right (left) or right (left) half turn, a change of 45 degrees is executed.

By the command: **Incline to the right (left)**, the guide, or guiding element, moves in the indicated direction and the remainder of the command conforms. This movement effects slight changes of direction.

In changing direction the leading subdivision executes the turn, or wheel, at the command **MARCH**, the guide taking his position when the change is made.

23. Full distance in column of subdivisions is such that in forming line to the right or left the subdivisions will have their proper intervals.

In column of subdivisions the guide of the leading subdivision is charged with the step and direction; the guides in rear preserve the trace, step and distance.

24. All details, detachments, and other bodies of Knights are habitually formed in single rank.

25. The designation line of sections, line of platoons, companies, etc., refer to the formations in which sections, platoons, companies, etc., each in column are in line.

26. The posts of officers, junior officers, color guard, staff, etc., in the various formations, of the platoon, commandery, battalion or regiment, will be described and shown in plates.

In all changes from one formation to another involving a change of post on the part of any of these, unless otherwise specified, posts are promptly taken by the most convenient route as soon as practicable after the command of execution for the movement; officers who have prescribed duties in connection with the movement ordered, take their new posts when such duties are completed.

27. As instructors, officers and junior officers go wherever their presence is necessary. As file closers it is their duty to rectify mistakes and insure steadiness and promptness in the ranks. In ceremonies officers, junior officers and special units must take their prescribed positions.

28. Brigade, regimental, battalion and staff officers

may be mounted. The staff of an officer forms in single rank three paces in rear of him, the right of the rank extending one pace to the right of a point directly in rear of him. Members of the staff are arranged in order of rank from right to left; the staffs in the same order according to the rank of their respective commanders. The orderlies, if present, are three paces in rear of the staff. When necessary to reduce the front of the staff and orderlies, each line executes three right, according to the principles of the U. S. cavalry drill regulations, and follows the Commander.

29. A junior, mounted, addressing a superior officer on foot, will first dismount.

Members of the staff, and orderlies, mount and dismount with their chief.

30. In making the about, an officer, mounted, habitually turns to the left.

31. When the Commander faces to give commands, the staff and orderlies do not change position.

32. When making or receiving official reports all officers will salute.

Where the word "Sir" is used by an officer in making a report, as "Sir, the parade is formed," the proper honorary title of the officer to whom reporting, may be prefixed, as "Eminent Sir," "Right Eminent Sir," etc.

Knighthood courtesy requires the junior to salute first, but when the salute is introductory to a report made at a ceremony or formation, to the representative of a common superior, as the adjutant, or other staff officer, etc., the officer making the report, whatever his rank, will salute first; the officer to whom the report is made will acknowledge by saluting that he has received and understood the report.

33. For ceremonies, such regimental and battalion junior officers as are dismounted, are formed five paces in rear of the color or standard, in order of rank from right to left. In column of threes or sections they march as file closers.

Other than for ceremonies, staff junior officers, and orderlies accompany their immediate chiefs unless otherwise

directed. If mounted, the junior officers are ordinarily posted on the right or at the head of the orderlies.

In all formations and movements a junior officer commanding a platoon carries his sword and takes the same post as an officer in like situation.

ORDERS, COMMANDS, AND SIGNALS

34. Officers and Knights fix their attention at the first word of command, the first note of the bugle, or the first motion of the signal. A signal includes both the preparatory command and the command of execution; the movement commences as soon as the signal is understood, unless otherwise prescribed.

35. Commanders or leaders of subdivisions repeat orders, commands, or signals whenever such repetition is deemed necessary to insure prompt and correct execution.

36. Prescribed signals are limited to such as are essential as a substitute for the voice under conditions which render the voice inadequate.

37. In these regulations an order embraces instructions or directions given orally or in writing in terms suited to the particular occasion and not prescribed herein.

Orders are employed only when the commands prescribed herein do not sufficiently indicate the will of the Commander.

38. In these regulations a command is the will of the Commander expressed in the phraseology prescribed herein.

39. There are two kinds of commands.

The PREPARATORY command, such as **Forward**, indicates the movement that is to be executed.

The command of EXECUTION, such as **MARCH, HALT**, or **WORDS**, causes the execution.

Preparatory commands are distinguished by small black letters, those of execution by **BLACK CAPITALS**.

Where it is not mentioned in the text who gives the commands prescribed, they are to be given by the Commander of the unit concerned.

The preparatory command should be given at such an interval of time before the command of execution as to admit of being properly understood; the command of execution should be given at the instant the movement is to commence.

The tone of command is animated, distinct, and of loudness proportioned to the number of men for whom it is intended.

Each preparatory command is enunciated distinctly, with a rising inflection at the end, and in such manner that the command of execution may be more energetic.

The command of execution is firm in tone and brief.

Oral commands are not habitually used for units larger than a battalion.

40. When giving commands to Knights, it is usually best to face toward them.

Indifference in giving commands must be avoided, as it leads to laxity in execution. Commands should be given with spirit at all times.

To secure uniformity, all officers should practice giving commands.

41. An officer should always have his sword drawn when giving a command, to Knights under arms.

Bugle Signals

42. Bugle Signals are only used for ceremonies, and with large bodies for street parades and marches. (See Bugle Signals and Calls, Par. 461.)

Whistle Signals

43. Attention to Orders. A short blast of the whistle. This signal is used on parades and marches when necessary to fix the attention of troops, or of their Commanders, or leaders, preparatory to giving commands, orders or signals.

Arm Signals

44. The following arm signals are prescribed. In making signals either arm may be used.

In making arm signals, the sword may be held in the hand.

Forward, MARCH; Right oblique, MARCH; Left Oblique, MARCH. Extend the arm vertically to its full extent and lower it to the front (right front, left front) until horizontal; at the same time move in the indicated direction.

Quick time, MARCH. Raise the right elbow to a position above and to the right of the right shoulder; extend the forearm to the left, right hand above the head.

HALT. Carry the hand to the shoulder; thrust the hand upward and hold the arm vertically.

Double time, MARCH. Carry the hand to the shoulder; rapidly thrust the hand upward the full extent of the arm several times.

Change direction or **Column right (left), MARCH.** The hand on the side toward which the change of direction is to be made is carried across the body to the opposite shoulder, forearm horizontal; then swing in a horizontal plane, arm extended, pointing in the new direction.

SCHOOL OF THE KNIGHT AND SQUAD

THE KNIGHT

45. Provision should be made for the proper instruction of newly created Knights in essentials of facings, marching, wheeling and sword manual to prevent their falling into awkward or bad habits, as well as to give grace and ease of movement. To this end the following exercises are prepared:

Individual Drill, Without Swords

46. The drill should always commence promptly at the appointed time. Punctuality, silence in ranks, and close attention during drill must always be insisted upon.

The instructor explains briefly each movement, first executing it himself if practicable. He requires the Knights to take the proper positions unassisted and does not touch them for the purpose of correcting them, except when they are un-

able to correct themselves. He avoids keeping them too long at the same movement, although each should be understood before passing to another. He exacts by degrees the desired precision and uniformity. Drills should be in fatigue uniform when possible and the sword manual not taught until the Knights have acquired some proficiency in the school of the Knight.

47. For preliminary instruction a number of Knights, usually not exceeding three or four, are formed as a squad in single rank facing to the front.

Position of the Knight, or Attention

48. Heels on the same line and as near each other as the conformation of the Knight permits.

Feet turned out equally and forming an angle of about 45 degrees.

Knees straight without stiffness.

Hips level and drawn back slightly; body erect and resting equally on hips; chest lifted and arched; shoulders square and falling equally.

Arms and hands hanging naturally; thumb along the seam of the trousers.

Head erect and square to the front, chin slightly drawn in; eyes straight to the front. Weight of the body resting equally upon the heels and balls of the feet.

The Rests

49. Being at a halt, the commands are: **FALL OUT; REST; AT EASE; 1. Stand at, 2. EASE; and 1. Parade, 2. REST.**

At the command **fall out**, the Knights may leave the ranks but are required to remain in the immediate vicinity. They resume their former places, at attention, at the command **fall in**.

At the command **rest**, the Knight keeps one foot in place but is not required to preserve silence or immobility.

At the command **at ease**, the Knight keeps one foot in place and is required to preserve silence but not immobility.



Stand at Ease

1. **Stand at, 2. EASE.** Being at order swords, at the command "Ease" carry the left foot twelve inches straight to the left, keeping the legs straight without stiffness, so that the weight of the body rests equally on both feet. At the same time incline the blade to the front by extending the right arm, without moving the point or changing the grasp on the hilt. Place the left hand behind the body, resting in the small of the back, palm to the rear, the attitude erect but not constrained. This secures dignified uniformity while resting.

1. **Parade, 2. REST.** Carry the right foot 6 inches straight to the rear, feet at an angle of 45 degrees, left knee slightly bent; clasp the hands, without constraint, in front of the center of the body, fingers joined, left hand uppermost, left thumb clasped by the thumb and forefinger of the right hand; preserve front, silence, and steadiness of position.

50. To resume the attention: 1. **Squad, 2. Atten-TION.** (Given with accent on the last syllable, -TION).

Eyes Right or Left

51. 1. **Eyes, 2. RIGHT (LEFT), 3. FRONT.**

At the command **right**, turn the head to the right oblique (45 degrees), eyes fixed on the line of eyes of the Knights, in, or supposed to be in, the same rank. At the command **front**, turn the head and eyes smartly to the front.

Facings

52. To the flank: 1. **Right (left), 2. FACE.**

Raise slightly the left heel and right toe; face to the right (a one-fourth turn), turning on the right heel, assisted by a slight pressure on the ball of the left foot; (TWO), place the left foot by the side of the right. **Left, FACE**, is executed on the left heel in the corresponding manner.

The right (left) half face, is executed similarly, facing 45 degrees, by the command, 1. **Half right (left), 2. FACE.**

To face in marching and advance, turn on the ball of either foot and step off with the other foot in the new direction; to face in marching without gaining ground in the new direction, turn on the ball of either foot and mark time.

53. To the rear: 1. **About, 2. FACE.**

Carry the toe of the right foot about a half foot-length to the rear and slightly to the left of the left heel without changing the position of the left foot; (TWO), face to the rear (a one-half turn), turning to the right on the left heel and right toe, and place the right heel by the side of the left.

Salute with the Hand

54. 1. **Hand, 2. SALUTE.**

Raise the right hand smartly till the tip of the forefinger touches the lower part of the headdress (if uncovered, the forehead) above the right eye, thumb and fingers extended and joined, palm to the left, forearm inclined at about 45 degrees, hand and wrist straight; at the same time look toward the person saluted; (TWO), drop the arm smartly by the side.

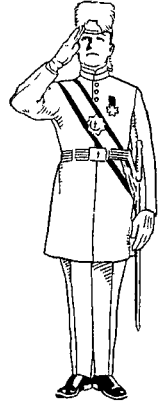

Hand Salute

Steps and Marchings

55. All steps and marchings executed from a halt, except right step, begin with the left foot.

56. The length of the full step in quick time is 30 inches, measured from heel to heel, and the cadence is at the rate of 120 steps per minute.

The length of the step in common time, is the same as in quick time; the cadence 90 steps per minute. Used in certain ceremonies, funerals, prelate's escort, etc., and for instruction.

The length of the full step in double time is 36 inches; the cadence is at the rate of 180 steps per minute.

The instructor, when necessary, indicates the cadence of the step by calling, one, two, three, four, or, left, right, the instant the left and right foot, respectively, should be planted.

57. All steps and marchings and movements involving march are executed in quick time, unless the Knights are marching in double time, or double time be added to the command; in the latter case double time is added to the preparatory command. Example: 1. Squad right, 2. Double time, 3. MARCH. (Similarly for common time.) Quick time may be resumed from double time or common time. Example: 1. Quick time, 2. MARCH.

58. The command of execution for all movements while marching is given as either foot strikes the ground, except as otherwise prescribed; the movement commences when the following foot is planted.

Quick Time

59. Being at a halt, to march forward in quick time: 1. Forward, 2. MARCH.

At the command forward, shift the weight of the body to the right leg, left knee straight.

At the command march, move the left foot smartly straight forward 30 inches, sole near the ground, and plant it without shock; next, in like manner advance and plant the right foot; continue the march. The arms swing naturally.

60. Being at a halt, or in march in quick time, to march in double time: 1. Double time, 2. MARCH.

If at a halt, at the first command shift the weight of the body to the right leg. At the command march, raise the forearms, fingers closed, back of the hands out, to a horizontal position along the waist line; take up an easy run with the step and cadence of double time, allowing a natural swinging motion to the arms.

If marching in quick time, at the command march, given

as either foot strikes the ground, take one step in quick time, and then step off in double time.

61. To resume the quick time: 1. Quick time, 2. MARCH.

At the command march, given as either foot strikes the ground, advance and plant the other foot in double time; resume the quick time, dropping the hands by the sides.

To Mark Time

62. Being in march: 1. Mark time, 2. MARCH.

At the command march, given as either foot strikes the ground; advance and plant the other foot; bring up the foot in rear and continue the cadence by alternately raising each foot about two inches and planting it on line with the other.

Being at a halt, at the command march, raise and plant first the left foot and then the right, as described above.

Any movement may be executed from mark time.

The Half Step

63. 1. Half Step, 2. MARCH.

Take steps of 15 inches in quick time, 18 inches in double time.

64. Forward, half step, halt and mark time, may be executed one from the other in quick or double time.

To resume the full step from half step or mark time: 1. Forward, 2. MARCH.

Side Step

65. Being at a halt or mark time: 1. Right (left) step, 2. MARCH.

Carry and plant the right foot 10 inches to the right; bring the left foot beside it and continue the movement in the cadence of quick time.

The side step is used for short distances only and is not executed in double time.

NOTE—The command halt is given when the feet are together; take another step, then halt.

Back Step

66. Being at a halt or mark time: 1. **Backward**, 2. **MARCH**.

Take steps of 15 inches straight to the rear.

The back step is used for short distances only and is not executed in double time.

To Halt

67. To arrest the march in quick time or double time: 1. **Squad**, 2. **HALT**.

At the command **halt**, given as either foot strikes the ground, plant the other foot as in marching; raise and place the first foot by the side of the other. If in double time, drop the hands by the sides.

To March By the Flank

68. Being in march: 1. **By the right (left) flank**, 2. **MARCH**.

At the command **march** given as the right foot strikes the ground, advance and plant the left foot, then face to the right in marching and step off in the new direction with the right foot. Execute by the left flank by inverse commands and means. (The right and left face in marching.)

To March To the Rear

69. Being in march: 1. **To the rear**, 2. **MARCH**.

At the command **march**, given as the right foot strikes the ground, advance and plant the left foot; turn to the right about on the balls of both feet and immediately step off with the left foot.

If marching in double time, turn to the right about, taking four steps in place, keeping the cadence, and then step off with the left foot.

Change Step

70. Being in march: 1. **Change step**, 2. **MARCH**.

At the command **march**, given as the right (left) foot strikes the ground, advance and plant the left foot; plant

the toe of the right foot near the heel of the left and step off with the left foot, both movements being executed in one count.

The Oblique March

71. The instructor causes the squad to face half right or half left, points out to the Knights their relative positions and explains that these are to be maintained in the oblique march.

1. **Right (left) oblique**, 2. **MARCH**.

Each Knight steps off in a direction 45 degrees to the right of his original front. He preserves his relative position, keeping his shoulders parallel to those of the guide (The Knight on the right [or left] front of the line or column), and so regulates his steps that the ranks remain parallel to their original front.

At the command **halt**, the Knights halt, faced to the front.

The command **halt** should be given on the left foot when halting from a right oblique, and on the right foot when halting from a left oblique.

To resume the original direction: 1. **Forward**, 2. **MARCH**.

The Knights half face to the left in marching and then move straight to the front.

If at a half step or mark time while obliquing the oblique march is resumed by the commands: 1. **Oblique**, 2. **MARCH**.

The Route Step

72. 1. **Route Step**, 2. **MARCH**.

At the command **march**, the Knights lengthen or shorten the step at will, so that it will break the cadence, and are not required to preserve silence nor keep step. The ranks cover and preserve distance. The swords, if not in scabbards, carried at will. (To be given in crossing bridges or at funerals where the distance to the cemetery is great.) To resume the cadence, step and silence: 1. **Squad**, 2. **ATTENTION**.

NOTE.—For setting up exercises see "Manual of Physical Training," U. S. A.

THE SQUAD

To Align the Squad

73. 1. Squad, 2. FALL IN.

At the command **fall in**, the tallest Knight takes position where the right is to rest, facing to the right. The Knights fall in quickly in rear, at a distance of ten inches, according to height. At the command, 1. **Left**, 2. **FACE**, they face to the left into line.

Alignments

74. The instructor first teaches the Knights to align themselves man by man; to this end he advances the two Knights on the right, three or more paces, and having aligned them, commands:

1. By file, right (left), 2. DRESS, 3. FRONT.

At the command **dress**, the Knights move up successively in quick time, shortening the last step, so as to be about six inches behind the alignment which must never be passed; each Knight then executes **Eyes Right**, and moves on the line taking steps of two or three inches, places his right arm lightly against the left arm of the Knight on his right, so that his eyes and shoulders are in line with those of the Knights on his right, shoulders square to the front.

At the command **front**, given when the ranks are aligned, the Knights turn their heads and eyes smartly to the front.

75. The Knights having learned to align themselves man by man, the instructor next aligns them by the command:

1. Right (left), 2. DRESS, 3. FRONT.

The base having been established, at the command **dress**, the entire rank moves forward and dresses up to the line as previously explained.

The instructor verifies the alignment from the right flank and orders up or back such men as may be in rear, or in advance of the line; only the men designated move.

At the command **front**, given when the rank is aligned, each man turns his head and eyes smartly to the front.

Whenever the position of the base file or files necessitates a considerable movement by the squad, such movement will be executed by marching to the front or oblique, to the flank or backwards, as the case may be, without other command.

Alignments to the rear are executed on the same principles, the Knights stepping back a little beyond the line, and then dressing up, by steps of two or three inches. The commands are:

1. By file, right (left), backward, 2. **DRESS**, 3. **FRONT**, or, 1. **Right backward**, 2. **DRESS**, 3. **FRONT**.

To March in Line

76. The Knights being correctly aligned, the instructor places a well instructed Knight on the side on which the guide is to be, and commands:

1. Forward, 2. MARCH.

At the command **march**, the Knights step off smartly with the left foot, Par. 59, the Knight acting as guide marching straight to the front.

The instructor observes, in marching in line, that the Knights touch lightly the elbow toward the side of the guide; that they open neither arm; that they yield to pressure coming from the side of the guide, and resist pressure coming from the opposite direction; that shortening or lengthening the step, they gradually recover the alignment and touch of the elbow, if lost, and that they keep the head direct to the front, no matter on which side the guide may be.

The instructor impresses upon the Knights that the alignment can only be preserved in marching, by the uniformity of the step, both in length and swiftness, by the touch of the elbow, and the maintenance of the shoulders square with the line of direction.

To March By the Flank

77. Being at a halt, the instructor commands: 1. **Right (left)**, 2. **FACE**. 1. **Forward**, 2. **MARCH**.

If in march, the instructor commands: 1. **By the right (left) flank**, 2. **MARCH**.

At the command **march**, given as the right foot strikes the ground, advance and plant the left foot, then turn to the right in marching and step off in the new direction with the right foot. Par. 52.

In the march by the flank the Knights cover each other, and keep to facing distance, that is, to such distance that in forming line the elbows will touch.

A rank faced to the right or left is called a column of files. To halt the column of files, the instructor commands: 1. **Squad**, 2. **HALT**, and, to face it to the front, 1. **Left (right)**, 2. **FACE**.

Marching in column of files, to march in line, the instructor commands: 1. **By the right (left) flank**, 2. **MARCH**.

To Change Direction in Column of Files

78. Being in march, the instructor commands: 1. **Column right (left)**; or, 1. **Column half right (left)**, 2. **MARCH**.

At the command **march**, the leading file turns to the right, or half right, on a moving pivot (with radius reduced), followed by the other files, who turn on the same ground.

To Oblique

79. Being well drilled in the principles of the direct march, the squad is taught to march obliquely. Marching in line, the instructor commands: 1. **Right (left) oblique**, 2. **MARCH**. At the command **march**, each Knight makes a half face to the right, and then marches straight in the new direction. See par. 52-71. The Knights no longer touch elbows, but preserve the line of the rank parallel to its former position by the eye only, glancing along the shoulders of the nearest files, toward the side to which they are obliquing, and regulating their steps so that the shoulders are about six inches behind the shoulders of the Knights on that side, and that the heads conceal the heads of the other Knights in the rank. The Knights all preserve the same length of step, and the same degree of obliquity.

To resume the original direction, the instructor commands: 1. **Forward**, 2. **MARCH**.

At the command **march**, each Knight makes a half face

to the left in marching, and then moves straight to the front. If the squad be at a halt, the Knights half face to the right, at the command **right oblique**, and step off at the command **march**.

Wheelings

80. Wheelings are of two kinds; on either fixed or moving pivot.

To Wheel on a Fixed Pivot

81. 1. **In circle**, 2. **Left (right) wheel**, 3. **MARCH**.

The Knight on the extreme right takes the full step and looks toward the pivot. All keep touch of elbows toward

Wheeling on fixed Pivot.

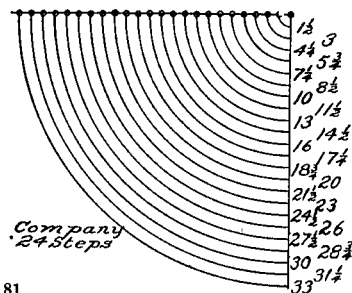
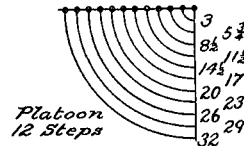

the pivot, head and eyes turned (eyes right) toward the marching flank, regulating the length of step accordingly. Thus continue until halted.

The fixed pivot is used in wheeling from line into column, or from column into line, the pivot Knight marking time in his place and turning to conform to the marching flank.

Wheeling on Moving Pivot.

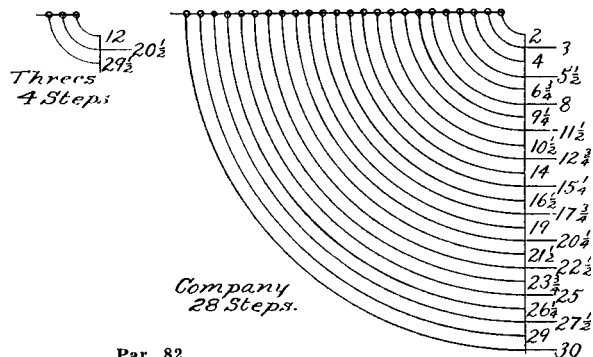
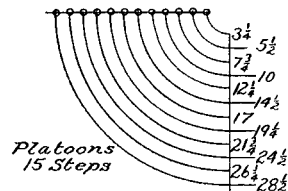
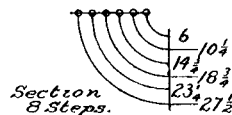

82. A wheel on a moving pivot, used in changing direction in marching, is made in the same manner, except that the pivot Knight takes a short step thus gaining ground forward, describing the circle with radius of 30 inches, regulating the length of his step to correspond with the marching flank.

The moving pivot is used in changing direction of column, and in some successive formations, the pivot Knight describing a circle the radius of which is always 30 inches.

NOTE—To wheel the commandery or platoon, see Par. 193. When platoons or larger subdivisions wheel in circle the guide will be the pivot.

MANUAL OF THE SWORD

83. Newly created Knights should at once be taught marching, drill and sword manual. Ease and grace can only be acquired by frequent exercise. Attention to minor details is essential in order to avoid the forming of awkward habits or taking incorrect positions. Carry the sword with a flexible wrist and without grasping the gripe tightly. The gripe should be held, at position of carry, by the thumb and forefinger, as if holding a pen, and covering about two-thirds of the gripe below the guard. Each command is divided into motions of one-half of a second, which should, at first, be explained and executed separately without reference to cadence. On the march the cadence corresponds with the step. The manual may first be taught by calling the numbers of motions, the command being prefaced by the words "By the numbers", No. ONE being executed at the command **swords**, or other command of execution, then **TWO, THREE**, etc., until the command "without the numbers", or until a command is given not in the sword manual. When on march if the swords are drawn and not at a carry, the Knights will, at the command **halt**, come to Carry Swords, without command. If in scabbard the left hand steadies same. While marching the hands may be allowed to swing forward and back three or four inches for the sake of ease and grace of carriage.

NOTE—With swords drawn or in scabbard, if desired, scabbards may be hooked up, uniformity being maintained. "Hooked up" means hanging by the front upper ring. If hooked up the scabbard must be unhooked before executing draw or return swords.

84. The sword consists of the hilt and the blade. The hilt is divided into the gripe and the guard.

The gripe is the handle grasped by the hand.

The guard is the cross piece between the gripe and the blade.

The blade is divided into the edge, back, sides and point.

The edge and back are determined by the hilt.

The right and left sides of the blade and gripe are the right and left sides in the position of carry swords.

The scabbard is the receptacle of the sword; the opening of same, its mouth.

The hand is in tierce, when it holds the gripe, with back of hand up, and in quarte, when it holds the gripe with back of hand down.

Unless the formation is in open ranks, the Knights under instruction should take intervals.

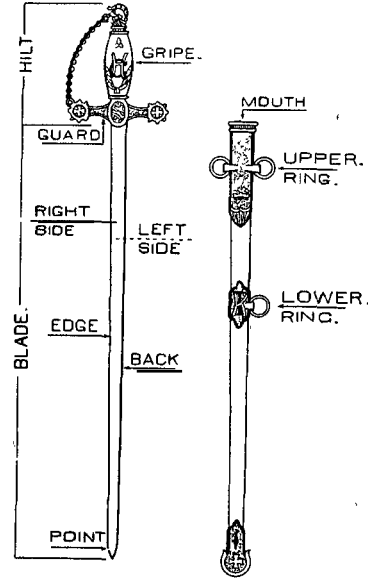

The Sword and Scabbard

85. Being in line at a halt with swords in scabbards: 1. **Sir Knights**, 2. **Draw**, 3. **SWORDS**.

1. At the command **draw**, grasp the scabbard with the left hand, near its mouth, incline the hilt a little forward. seize the gripe with the right hand, and draw the blade until the right forearm is horizontal, back of hand against the breast. **SWORDS**, draw the sword quickly, raising the arm

to its full length, at an angle of about 45 degrees, the sword in a straight line with the arm, edge down, extending in the same direction as the right foot. (TWO) Bring the back of the blade against the shoulder, the blade vertical, back of the

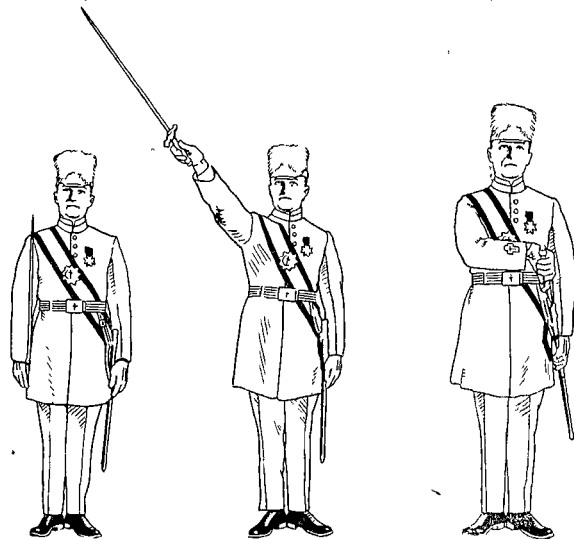

Carry Swords

Draw Swords
Second MotionDraw Swords
First Motion

gripe to the rear, the arm nearly straight down, the thumb and forefinger embracing the gripe, the thumb against the thigh, the other fingers extended and joined in the rear of the gripe. This is the position of Carry Swords. From this position all movements of the sword manual begin, unless otherwise provided.

In all marching movements, except route march, at the command halt, unless otherwise provided, the sword, if drawn, will be brought to the carry without command.

86. 1. From the right take sword intervals, 2. MARCH.

At the first command, all the Knights except the one on the right, who remains at Carry Swords, execute eyes right, raise the right hand in front of and as high as the right shoulder, the back of the hand to the front, and drop the sword blade horizontally to the right, edge up. MARCH, all the Knights except the right file, execute left step. As soon as each Knight has gained an

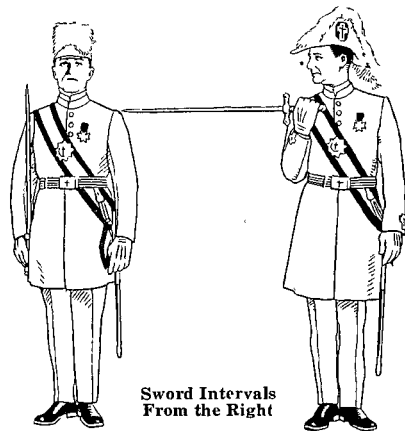
Sword Intervals
From the Right

interval so that the point of his sword will clear the left arm of the Knight on his right, he halts, executes front, and resumes Carry Swords.

NOTE — This movement intended only as preparatory to Par. 116 to 135.

87. 1. From the left take sword intervals, 2. MARCH.

Is executed as above, except that the eyes are turned to the left, the right hand is carried across the body and

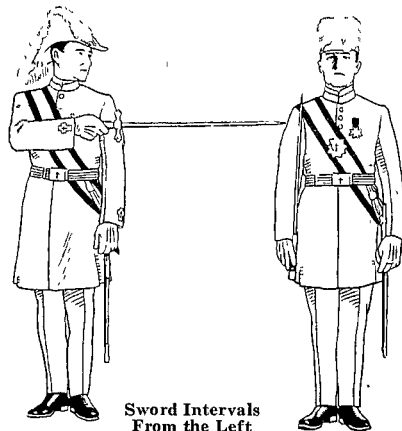
Sword Intervals
From the Left

touches the left arm, the right forearm horizontal, the sword extended in prolongation thereof, edge down.

87a. 1. On the right (left) close intervals, 2. MARCH.

The Knight on the right (left) stands fast, the others face him and march forward halting successively when the interval is closed, and facing to the front.

88. 1. Present, 2. SWORDS.

Raise and carry the sword to the front, cross hilt as high as the chin and six inches in front of the neck, edge to the left, point six inches farther to the front than the cross hilt, thumb extended on the back of the gripe, wrist straight, all fingers grasping the gripe.

89. 1. Carry, 2. SWORDS.

Resume the carry in one motion, without throwing the right hand to the front, or the point to the rear.

90. 1. Salute, 2. SWORDS.

Execute present swords. (TWO) Drop the point of the sword, edge to the left, to about fifteen inches in front of and in prolongation of the right foot, arm hanging naturally, the elbow close to the body, the back of the hand down.

91. 1. Carry, 2. SWORDS.

Resume the position of carry swords.

The salute swords, is the present swords, used by officers. If not in ranks they will at the command present, execute present swords, and at the command swords, execute the second motion of salute swords. Junior Officers execute the present unless otherwise prescribed.

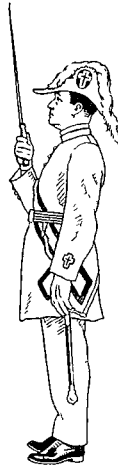

Present Swords

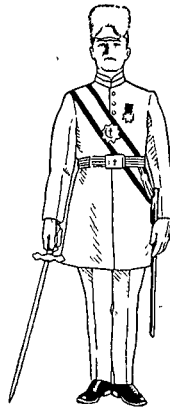

Salute Swords
Officers Present

92. 1. Order, 2. SWORDS.

Drop the sword point to the ground, blade inclined to the rear, back of blade to the front. (TWO) Bring the blade to a vertical position against the right toe, and place the hand on top of the hilt, three fingers in front of the gripe, thumb and little finger in the rear, elbow close to the body.

93. 1. Carry, 2. SWORDS.

Resume the position of carry swords, in one motion.

94. 1. Support, 2. SWORDS.

Bring the sword to the position of present. Par. 88.

(TWO) Carry the sword vertically to the left side, lowering the right hand until the forearm is horizontal, edge of the sword to the front, the right hand firmly grasping the gripe about three inches below the guard, at the same time grasp the right forearm near the elbow with the left hand, the left forearm along and in front of the right forearm, the thumb of the left hand over and supported by the right forearm near the elbow, fingers of the left hand extended and joined, the guard resting on the left arm near its elbow, the blade vertical, edge to the front.

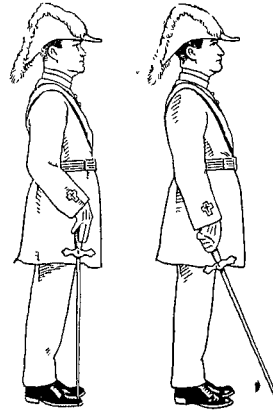

Order Swords

First Motion
Order Swords

95. 1. Carry, 2. SWORDS.

Bring the sword to the position of present, at the same time drop the left hand by the side. (TWO) Bring the sword to the carry. Par. 89.



Support Swords

96. 1. Swords, 2. PORT.

Seize the blade in front of the right shoulder with the fingers and thumb of the left hand, the thumb to the rear, the left elbow close to the body. (TWO) With the left hand bring the sword diagonally across and about one inch in front of the body, edge down, the left hand at the height of the left shoulder, the thumb extended along the blade, the fingers closed, back of the hand down, the right hand grasping the hilt and nearly in front of the right hip.

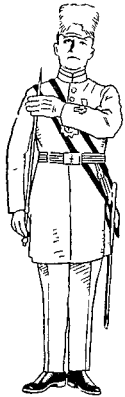

Carry from
Port
First Motion

right, see Par. 49, the blade resting along the right forearm, the right hand retaining the same position on the gripe as at the carry.

99. 1. Carry, 2. SWORDS.

Resume the carry in one motion.



Swords Port



Arm Rest-Swords

100. 1. Shoulder, 2. SWORDS.

Raise the right hand in front of the armpit and place the flat of the sword blade on the right shoulder, the edge to the left, the elbow close to the body, the point of the sword obliquely to the left, and in the rear, clearing the chapeau.

101. 1. Carry, 2. SWORDS.

Resume the position of carry swords.

102. 1. Reverse, 2. SWORDS.



Reverse Swords

Drop the blade forward and down until it is directed towards a point about one pace in front of the right foot, at the same time allow the fingers to grasp the lower part of the gripe, and move the hand forward about twelve inches. (TWO) Carry the sword by a wrist movement so that the blade will swing to the rear, the point downward at an angle of about 45 degrees, the edge up. As the sword swings into position under the right arm pit, bring the hand in front of the right armpit and grasp the gripe with the thumb and forefinger of the right hand, the other fingers successively curved, resting the blade between the right arm and the right side. The end of the hilt remains about nine inches in front of the right shoulder.

103. To resume the carry: 1. Carry, 2. SWORDS.



Shoulder Swords

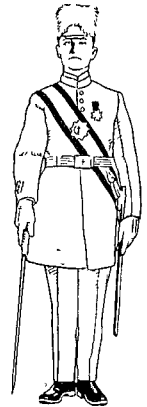

Reverse Swords
First Motion

Bring the sword to the first position of reverse. (TWO) Resume the position of carry swords.

On long marches the corresponding position of left reverse may be taken.

104. 1. Left reverse, 2. SWORDS.

Extend the right hand to the first position of reverse. (TWO) With the right hand swing the sword to the position of left reverse. (THREE) Seize the gripe with the left hand and drop the right hand to the side.



Parade Rest

105. 1. Carry, 2. SWORDS.

Seize the gripe with the right hand and drop the left hand to the side. (TWO) Carry the sword to the first position of reverse swords. (THREE) Resume the position of carry swords.

106. 1. Parade, 2. REST. Being at the carry or order swords.

Drop (carry) the sword point to the ground in front of the center of the body on a line with the left toe, edge to the right, the palm of the right hand resting on the end of the hilt; the thumb and fingers extended and joined against the gripe, the left hand clasped over the right; at the same time carry the right foot six inches straight to the rear, the left knee slightly bent, the body erect, Par. 49.

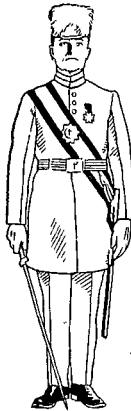

Attention
From
Parade Rest

107. 1. Squad, ATTENTION, 2. Carry (Order), 3. SWORDS.

At the command attention, bring the right foot to the side of the left; drop the left hand to the side, and carry the hilt to the right side, leaving the point undisturbed. At the command swords, resume the position of carry (order) swords in one motion.

108. 1. Inspection, 2. SWORDS.

Execute present swords, and turn the wrist to show both sides of the blade, resuming the carry when the inspector has passed.



Invert Swords
First Motion

hilt to the right side and grasp it with the right hand (first position of invert). (TWO) Place the sword in the position of carry, the left hand at the right shoulder, turning the hand, see Par. 97. (THREE) Drop the left hand to the side.

NOTE—Invert swords is used for ceremonial purposes, for devotions, as in church service during prayer in lieu of present swords.

109. 1. Invert, 2. SWORDS.

Drop the point of the sword directly forward about fifteen inches, grasping the blade (about nine inches from the guard) with the left hand palm to the front. (TWO) Release the gripe with the right hand and invert the sword with the left hand to a position about four inches in front of the center of the body, blade vertical, edge to the right, guard at the height of the chin, grasp the blade with the right hand at the height of the belt.

110. 1. Carry, 2. SWORDS.

Release the right hand and swing the point of the sword forward and upward, at the same time lower the side and grasp it with the right hand (first position of invert). (TWO) Place the sword in the position of carry, the left hand at the right shoulder, turning the hand, see Par. 97. (THREE) Drop the left hand to the side.



Invert Swords

111. 1. Guide, 2. SWORDS.

Bring the sword vertically in front of the center of the body, the right hand as high as the neck and six inches in front of it, back of the gripe to the right, at the same time clasp the left hand over the right, elbows close to the body.

To return to the carry: 1. Carry, 2. SWORDS.

Resume the position of carry swords in one motion.

NOTE—Upon taking post on the line, as in successive formations in battalion drill, guides will take this position without command, returning to the carry at the command guides post.

112. 1. Sir Knights, 2. Return, 3. SWORDS.

At the command return, seize the scabbard near the mouth with the left hand, inclining it a little forward, and keeping the right hand near the body, drop the sword

blade forward and to the left so that the point is about six inches from the floor and pointing to a line which is a prolongation of the left foot. Move the sword hand to the left, then raise the hand, drawing the sword blade between the first two fingers of the left hand. Insert the point of the blade in the mouth of the scabbard, edge to the front, assisted by the thumb and fingers of the left hand, eyes to the front, thrust the blade into the scabbard until the right forearm is horizontal (first motion of draw).

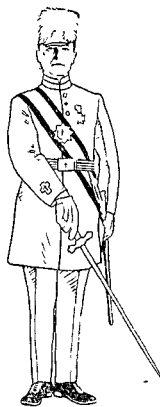

Guide Swords

Return Swords
First Motion

(Par. 85.) (SWORDS) Return the blade smartly and drop the hands to the sides.

NOTE—In inserting the point avoid turning the scabbard to meet the sword.

113. 1. Secure, 2. SWORDS.

Seize the scabbard with the left hand, palm to the front, the thumb to the left, the arm extended. (TWO) Raise the scabbard, bring the left hand in front, nearly as high as the belt and a little to the left of the belt clasp, the scabbard resting along the left forearm, the back of the hand down, the guard at the hollow of the elbow. (Executed only when swords are in scabbards.)

114. 1. Drop, 2. SWORDS.

Lower the scabbard to its place, and detach the hand.

NOTE—Only to be used by officers, on ceremonies, and in double time.

Position of the Sword at Double Time,
in Ranks

115. 1. Double time, 2. MARCH.

At the first command take the position of Shoulder Swords, left hand steadying the scabbard, thumb in front. (If swords are in scabbards take the position of Secure Swords.) At the command march take the double time.

This rule is general in all commands for double time.

SWORD MANUAL (Ritual)

NOTE—While important that all movements in the school of the Sir Knight, such as sword manual, facings, steps, marching, kneeling, etc., be uniform, for both indoor and outdoor drill, it is not intended that Par. 116 to 135 shall be mandatory for asylum ceremonies, although revision to secure uniformity with this adopted standard is recommended.

116. To form lines at open ranks for the reception of

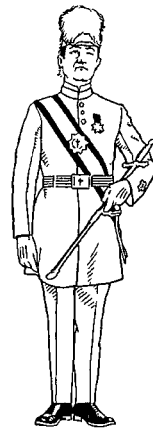

Secure Swords

a grand officer, or to communicate, the line should be moved forward to the position which the front rank will occupy. Ranks will then be opened, Par. 191. After "front," the Commander commands:

117. 1. Files, Cover, 2. Front rank about, 3. FACE. At the command face, the front rank files face about, and the rear rank files take two right steps; the guides take post at the foot of the lines, and the officers at the head, (with intervals at open ranks), the Generalissimo (leader 1st platoon) on the left of the front rank, the Captain General (leader 2nd platoon) on the right of the rear rank, the Commander two paces to the right, midway between and facing the lines.

To reform the line, the Commander commands:

118. 1. Re-form line, 2. Front rank about, 3. FACE, 4. Close ranks, 5. MARCH. At the first command the officers and guides proceed to their posts in line. At the command face, the front rank executes about face; at the command march, ranks are closed.

119. 1. On, 2. GUARD.

Turn the left foot square to the left, turning on the left heel, and plant the right foot firmly about eighteen inches to the front, feet at right angles, the weight resting principally on the right foot, the shoulders oblique to the front, head and eyes square to the front. At the same time raise the sword hand on a line with lower part of the belt and about two inches from it, the guard three or four inches to the right of the belt clasp. Drop the sword diagonally to the left, the blade about 18 inches in front of the left shoulder, edge to the front, thumb on back of gripe. The sword held without constraint.

120. 1. Carry, 2. SWORDS.

Resume the position of attention at carry swords.



On Guard

Cuts or Parries

121. In giving the parries, first take the position on guard, keep the feet at right angles and look into the eyes of the Knight opposite. The flats of the blades should be crossed about ten inches from the points, the sword arm straight; parries should be given with spirit but the swords touching lightly.

1. Parry, 2. ONE. Raise and extend the arm, back of the hand to the left and up, without changing the grasp, wrist as high as the head, the edge of the sword up, the blade in prolongation of the forearm, and engage the sword of the Knight opposite.

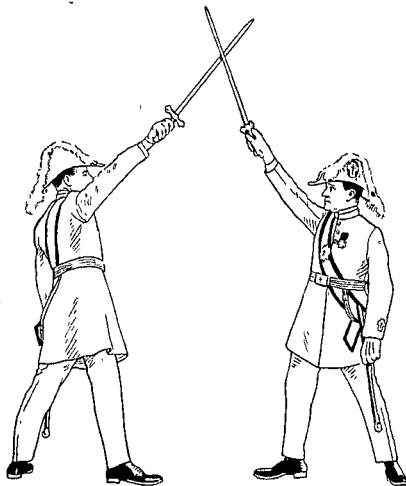

Parry One—Cross Swords

1. Parry, 2. TWO. Disengage the sword and describe a circular movement toward the rear and right, back of the hand down, edge of the sword down, the hand on a line with the head, and engage the opposite sword on the right side, crossing the blades as before.

1. Parry, 2. THREE. Disengage the sword and describe a circular movement toward the left and downward, engage the opposite sword on the left side, the point of the sword near the ground, the edge upward, the back of the hand to the left, and cross blades.

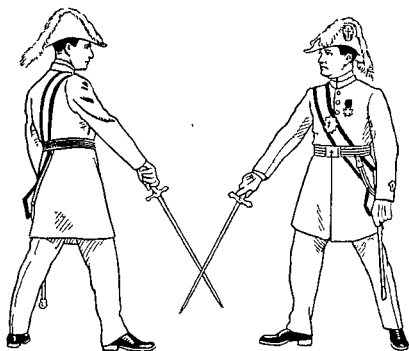

Parry Three

when parries, 1, 2, 3, and 4, or parts of same as required, will be executed by the proper commands. After each word the position of on guard will be resumed at the command: 1. On, 2. Guard.

After the last word:

123. 1. Carry, 2. SWORDS.

At the first command come to the position of on guard, Swords, bring the right foot back to the original line and resume the carry.

124. 1. Wield, 2. SWORDS.

Raise the sword to the second position of draw swords. Wield the sword four times in a circular motion to the left, stopping at the first position of wield swords.

125. 1. Carry, 2. SWORDS.

Resume the position of carry swords.

To Form Arch of Steel

126. The commandery being formed in two lines, facing inward, and about three paces apart, at carry swords, the

1. Parry, 2. FOUR. Come directly to the position of Parry One.

122. The parries may be taught by numbers, but when a commandery is well instructed, they may be given, one division to another, by calling the number of the parry required, as follows: First Division— to the Second Division—.

1. On, 2. GUARD,

command will be given: Form arch of steel, 1. Cross, 2. SWORDS.

(ONE) Execute present swords. (TWO) Advance the right foot and take the position of Parry One. See Par. 119-121-165.

1. Carry, 2. SWORDS.

Bring the sword to the position of present and replace the feet. (TWO) Resume the position of carry swords.

127. 1. Rest on, 2. SWORDS. (From Kneel at Parade Rest. Par. 132.)

Incline the head forward, the eyes fixed on the point of the sword.

To resume attention, 1. Sir Knights, 2. ATTENTION. At Sir Knights, raise the head.

The Rest on Swords can also be executed from the parade rest without kneeling.

128. 1. Charge, 2. SWORDS.

Turn on the left heel, placing the toe square to the left; at the same time plant the right foot forward with a slight shock about eighteen inches, the feet being at right angles, the weight of the body resting on the right foot. At the time of planting the feet extend the arm to its full length, at the height of the shoulder, back of the hand down, the blade in prolongation of the arm, and pointed at the opponent's breast.

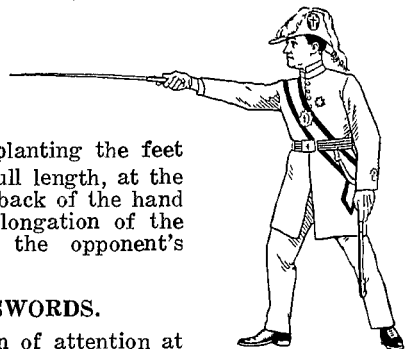

Charge Swords

129. 1. Carry, 2. SWORDS.

Resume the position of attention at carry swords,

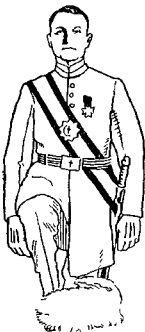

Un-cover

Deposit
Chapeaux

130. 1. Un- 2. COVER.

At the command **Cover**, take the chapeau by the front piece with the left hand. (TWO) Raise the chapeau from the head and place it on the right shoulder, slightly to the front, holding it in that position with the left hand.

131. 1. Re- 2. COVER.

Replace the chapeau on the head. (TWO) Drop the hand to the side

NOTE—Uncover is never executed unless the swords are sheathed, at an order, or (with the right hand) when at a secure.

132. 1. Sir Knights, 2. KNEEL. (Swords sheathed.)

Carry the left foot about twenty-four inches to the rear. (TWO) Kneel on the left knee, the body and left thigh erect, the right leg below the knee nearly vertical, the right hand hanging at the side.

NOTE—May also be executed from parade rest, without moving the hands, see Par. 106.

The triangle guard kneel, from order swords, same as above, except as to the right hand, which rests on the top of the sword hilt.

To communicate, both lines are moved forward one pace before kneeling.

133. 1. Deposit, 2. CHAPEAUX. (From Uncover, kneeling.)

At the second command, place the chapeau on the ground to the left of the right foot, feathers to the left, peak pointing toward the body. The cap is placed with the crown down. (TWO) Resume position of kneel.

Kneel
Rest on-Swords
Par. 127

134. (After communication) 1. Secure, 2. Chapeau, 3. RE-cover, 4. Sir Knights, 5. Rise.

At the second command grasp the visor of the chapeau with the left hand, place it on the right shoulder. (THREE) Replace the chapeau on the head and drop the hand. (FIVE) All rise bringing left feet forward into line.

Both lines are now moved backward one pace.

NOTE—The uncover should be made after kneeling and before rising.

135. (After devotion) 1. Re-cover, 2. Sir Knights, 3. Rise.

(ONE) Replace the chapeau on the head and drop the hand to the side. (THREE) All rise bringing left feet forward into line.

Alarms

136. Alarms on doors, when done with the sword, should be made with the flat side of the point of the blade rather than with the hilt.

SILENT MANUAL

136a. To secure a machine-like accuracy of the manual, and for spectacular purposes, any desired combination of sword movements may be executed, consecutively, without pause, in regular cadence, without commands, as a "Silent Manual," of which the following will serve as an illustration:

1. Continue the Manual, 2. Present, 3. SWORDS.

Present-Carry, Salute-Carry, Order-Carry, Support-Carry, Port-Carry, Arm Rest-Carry, Shoulder-Carry, Reverse-Carry, Parade Rest-Kneel-Rest-on-Swords, Attention, Rise-Carry, Return Swords, Secure-Drop, Un-Cover, Re-Cover, Hand Salute.

SCHOOL OF THE OFFICER

137. The importance and responsibility of the officer in all Templar and military formations can not be over-emphasized. He should be a model of promptness, dress, efficiency and appearance, should be devoted, enthusiastic and untiring, and to succeed must be a student and a gentleman.

Discipline and courtesy are as essential among Templars as with military men and must be maintained, yet the leader should not forget that his men are gentlemen, who out of ranks, are his peers.

138. Officers are described as those above and including the rank of Captain General, and Past Commanders; those under that rank are classed as junior officers, the distinction being made to obtain the necessary parity with military formations and terms. However, in Templary no difference in class is recognized, excepting in the measure of responsibility, templar rank usually being but temporary, and resulting often only from an accident of age or tenure.

138a. The laws and decisions of the Grand Encampment do not permit the wearing of the insignia of the U. S. Army, on the templar uniform, and it is also a technical violation of the National Defense Act. In large assemblies and organizations some designation of templar military rank often seems necessary, but this need can be met only by authority of the Grand Encampment.

139. The recommendation for systematic training in a school for officers and junior officers is here renewed. The requirements should be regular attendance, strict discipline, and prompt commencement and dismissal. After the oral lesson the squad should be thoroughly drilled in each movement. There should be the keenest attention and no talking in ranks. No faulty movement should ever be overlooked. The officers should alternate as instructors, and all should be practiced in giving commands. If the Commander is not in charge he should appoint a chief instructor, preferably on permanent detail.

140. All drill commands to Templars under arms, meaning equipped with sword and accoutrements, are given with sword drawn.

141. Unless otherwise directed, officers (see Par. 143) omit the manual except the carry and order, parade rest, rest-on-swords, and kneelings; in rendering honors they execute the present, un-cover and re-cover; they draw and return without command.

142. Officers may be in "formation" but are never in "ranks," unless temporarily so absorbed, when they will drill and present like other Knights. Whether in the station of officer, junior officer, or Knight, by appointment or otherwise, a Knight Templar will always conform with the honors and courtesies relating to that grade.

143. Officers salute, by the officers present, or salute swords.

Officers or junior officers, commanding companies, platoons, a division or an escort, will use the salute swords; at the command present, they will execute the present, and at swords, will take the position of salute swords.

Officers in ranks taking the place of Knights, and all other junior officers, execute the present swords prescribed for Knights.

144. In double time, officers (see Par. 143) bring the sword across the body at an angle of forty-five degrees, edge out and about six inches in front of the breast, right hand forward, forearm horizontal, blade crossing opposite the left shoulder, left hand steadying the scabbard (if not hooked up), right arm swinging easily.

145. When the Captain General, Adjutant, or other officer in the Asylum or before the commandery, publishes orders, he will return his sword before reading the orders, then draw and come to the carry.

146. On drill or march the commanding officer goes wherever his presence is necessary, but in ceremonies every officer, junior officer and Knight must take the position and post prescribed.

FORMATION FOR PUBLIC PARADE

With Standard Guard, Eminent Commander's Staff, and Band

147. The commandery will be formed as provided in the School of the Commandery, Par. 189, and if large numbers are present, may be formed as a battalion or regiment. If the Eminent Commander does not assume the command he will designate an acting commander to do so, and will provide for the detail of necessary officers, junior officers and guides, including battalion or regimental staff when required.

148. The Senior Warden (or Adjutant) will then command: 1. (Such and such) platoons (or companies), 1. Left step, 2. MARCH, halting them when an interval has been gained sufficient for the Standard Guard, which is composed of the Standard Bearer, Sword Bearer, Warden and State Color bearer, if present. See Note, Par. 183.

When there are four or five platoons the Standard Guard will be placed between the second and third platoons, when less than four, between the first and second, when six or seven, between the third and fourth, etc.

The Standard Guard takes position five paces in front of the left of the commandery, faced to the right.

After the interval in the line has been gained, the Senior Warden (or Adjutant), from position at right of the interval, commands: 1. Present, 2. Swords, 3. Standard Guard Post, 4. MARCH, when the Standard Guard, under command of the Sword Bearer, will march forward opposite its interval, wheel to the left, halt, about face, march through the interval one pace in rear of the line, halt, about face, step into line and dress to the right without command. When the Standard Guard is posted, the Warden (or Adjutant), commands carry swords, faces the Commander, salutes, and reports, Eminent Sir, or, Sir, the commandery is formed, and takes his post.

149. In column or line of subdivisions, the Standard Guard is posted midway between the platoons, or companies, and is maneuvered in conformity with the movement of the

subdivisions, under direction of the Sword Bearer, who is its chief.

150. As a means of identification, the name and number of the organization may be shown by a guidon or marker—a small flag or banner of cloth or metal, to be carried on the right and abreast of the leading sub-division.

151. In these regulations, while no requirement is made for the Standard Guard in commandery drill, the Colors should always be carried in public parade. See Par. 153.

152. The formation may include several commanderies, when, if desired, the colors of all may be grouped, under the direction of the Grand Sword Bearer, or the Senior Sword Bearer, and will take the same relative position as provided for the colors of a commandery; the formation of the colors may be in line or column, and in order of the rank of the respective commanderies.

The Standard Guard

153. The Grand Standard is not a parade banner and is recommended never to be carried in public parade. See Note, end of Par. 159.

For public parade the Colors consist of a National Flag, a Beauceant, and a State Color, if present, see Par. 183.

The Beauceant will salute with the commandery at all commands to present swords, and as otherwise provided.

The State Color salutes in the ceremony of Escort-to-the-Color, and when saluting the Grand Master or Grand Commander or their official representatives, but in no other case.

The National Flag never renders or acknowledges any salute.

If marching the salute is executed when six paces from the officer; the carry is resumed when six paces beyond him.

Colors are said to be "cased" when furled and protected by the oilcloth covering.

Manual of the Color

154. At the carry, the heel (foot) of the pike (staff),

rests in the socket of the sling; the right hand grasps the pike at the height of the shoulder.

At the order the heel of the pike rests on the ground near the right toe, the right hand holding the pike in a vertical position.

At parade rest the heel of the pike is on the ground as at the order; the pike is held with both hands in front of the center of the body, left hand uppermost.

The order is resumed at the command, **attention**.

The left hand assists the right when necessary.

The carry is the habitual position when on the march.

The order and parade rest are executed with the commandery.

The color salute: Being at a carry, slip the right hand up the pike to the height of the eye, then lower the pike by straightening the arm to the front.

155. The following is published for the information of all concerned:

(a) In decorating with the National Flag, never festoon or drape it. Hang it flat. Par. 460.

(b) If hung so stripes are horizontal, union should be in the left upper corner.

(c) If hung perpendicularly, union should be in the left upper corner.

(d) When carried in parades or crossed with other flags, the National Flag should always be on the right.

(e) The National Flag should never be placed below a person sitting.

The Eminent Commander and Staff

156. If the Eminent Commander does not assume the command, he will designate an Acting Commander, Par. 2. The Eminent Commander with his staff will then form on the right of the commandery, the left element on a line and six paces to the right of the right guide. Par. 157.

The staff will consist of the Prelate and any other officers, junior officers, or Past Commanders, not otherwise absorbed in the formation.

In line, the staff will form in order of rank, the Eminent

Commander on the right, and the Prelate, Treasurer and Recorder on his left, two paces removed.

Past Commanders, for public parade and ceremonies, take position, in order of rank, on the left or in rear of the first three officers of the commandery, unless on detail or absorbed in the lines. Par. 338, and Statutes G. E. Sec. 195.

In column, the Eminent Commander will march at the head with the next two in rank forming a triangle, each, one pace from him to the right and left and two paces retired; the other members of the staff, following in column of twos, threes or sections, and conforming to the movements of the commandery.

The Eminent Commander gives orders to his staff in a tone of voice loud enough to be heard by them only. If a large number of past officers are present, he may designate a Past Commander to direct them. The swords of the Eminent Commander and his staff are not drawn but carried at a secure, except at inspection or review, when if not drawn they may be hooked up.

When the Eminent Commander is in command of the lines, the staff, if desired, may still be formed and maneuvered as above described, under the direction of the senior officer or designated Past Commander. There is, however, no objection to its members being absorbed in the commandery formation.

The Band

157. The band, if present, will take position in close order, its front rank on a line with the commandery, its left, six paces to the right of the Eminent Commander, or the right guide. The Eminent Commander gives the order to move.

If a marshal has been designated, see Par. 457, he, with his staff, precedes the band; the Eminent Commander, and staff, may likewise do so at his pleasure.

The Eminent Commander and staff, and distinguished visitors, may, if they prefer, ride in carriages in which case the carriages precede the band.

ESCORTS OF HONOR

158. Escorts of honor are detailed for the purpose of receiving and escorting commanderies and officials of high rank. The escort may consist of a commandery or of a subdivision.

The Knights for this purpose should be selected for their knightly appearance and superior discipline.

The escort forms in line opposite and facing the place where the commandery is quartered.

The band will be on the flank of the escort toward which it will march.

The commander of the escort will direct an officer to wait on the Commander and present his compliments, informing him that the escort is in readiness.

The commandery, or distinguished party, marches past and in front of the escort and forms line and halts in prolongation of line of escort, after passing the band, its flank twenty-four paces from the band of the escort.

NOTE—Distances may be reduced as required by lack of numbers or space.

When the head reaches flank of escort the escort will present swords and remain in that position until the rear has passed the band of the escort.

The commandery or the personal escort to the distinguished party, in marching past the escort will be at carry swords; the Commander and officers saluting with the sword, holding in that position until rear of command passes band of escort.

When the commandery has passed escort and band, the escort will come to carry swords.

When the commandery is in position, the escort will form in column of threes, or sections, and, headed by the band, march past the commandery, or distinguished party.

The escort will be brought to carry swords in marching past, the officers saluting, as before explained.

The commandery or escort in line will present swords as explained.

When the rear of escort has passed, the commandery in line will break into column and follow at twenty-four paces distance.

An officer will be detailed to accompany the commandery escorted and assist them in the arrangements.

When an officer of high rank is to be escorted an officer will be detailed to attend him. The escort will receive him with present swords.

When the escort arrives at destination it will form line and halt while the commandery marches past.

The same honors will be given as before explained, except that the commandery does not halt, but continues on to its quarters. If the escort is also to go to quarters with the commandery it will follow as explained.

When the position of the escort is at a considerable distance from the point where the commandery or official is to be received, as, for instance, where a courtyard or wharf intervenes, a double line of Knights is posted from that point to the escort, facing inward; the Knights will successively salute as the commandery or official passes and will then join the escort. Par. 285.

CHURCH PARADE

159. The commandery should attend church at least once a year. On arriving at the church the line is formed in front of and facing the church.

The commandery will present swords and the Standard Guard will march into the church in column of files.

When the Standard Guard enters the church the commandery will be brought to carry swords.

The Colors will form line facing the chancel at the order.

The color bearer will advance and place the National Flag on the right in socket provided and stand at attention in front of it. The National Flag is placed at the right of the chancel—not the right of the color bearer. The Standard, Beauceant and State Color will in like manner be deposited, the Standard Guard standing at attention.

The commandery will return swords, enter the church at secure swords, in column of files, un-cover (with the right hand) and be seated at a signal or command of the commander.

The Standard Guard will be seated at the same signal.

NOTE—If the attendance is large, entrance and egress should be made in two or more columns by different doors and aisles.

After the services the commandery will march from the church in column of files (may be left in front), and re-form line facing the entrance. The Standard Guard will take the banners, reform column of files with the National Flag in front and march out of the church.

When the National Flag appears at the entrance the Commander will command: 1. Present, 2. SWORDS, face to the front and present sword.

The Standard Guard will form in line six paces in front of the Commander, facing the commandery, the National Flag on right, and march to its post; when they have arrived in line the commandery will be brought to carry swords.

The commandery will then be marched to the Asylum and dismissed.

NOTE—It is permissible to carry the Grand Standard on Church Parade, or better, it may be demounted and set up in the church.

HONORS AND SALUTES

160. The composition consisting of the words and music known as the "Star Spangled Banner" is designated the National Anthem of the United States of America.

At all parades and ceremonies under arms, the commandery will render the prescribed salute and will remain in the position of salute while the National Anthem is being played.

If not under arms, the commandery will be brought to attention at the first note of the National Anthem, or To The Color, and the salute rendered by the officer in command.

When the National Anthem is played at any place where Sir Knights are present, all not in formation will stand at attention facing toward the music; if the National Flag is present they will face toward it.

If in uniform or civilian clothes, covered, they will uncover at the first note of the anthem, holding the head dress on the right shoulder, and so remain until its close, except that in inclement weather the head dress may be slightly raised. If uncovered, they will salute with the hand, at the first note of the anthem, retaining the position of salute until the last note.

The same rules apply when To the Color is sounded as when the National Anthem is played.

The National Anthem shall be played through without repetition of any part not required to be repeated to make it complete.

The playing of the National Anthem as part of a medley is prohibited.

161. Sir Knights not in formation will on all occasions salute the National Flag when carried by a body authorized by law or regulation to carry it.

When the National Flag passes a commandery or subdivision of Knights they will be brought to attention and the Commander and officers will salute.

Officers, only, will salute while marching in formation. The Knights will be at carry swords when marching honors are given.

162. In rendering honors the commandery or subdivision will be faced to the front; they will not present swords when facing to a flank.

163. In order to promote a more general reading of the first page of the Ritual an extract is here inserted:

"Officers will salute with sword or hand, according as the sword is drawn or in the scabbard. Upon addressing or being addressed, the junior will always make the first salute, which will be acknowledged by the senior.

"If the salute is with the sword, both come to carry simultaneously and stand at attention; or the junior may stand at salute while making a short report.

"They should always exchange salutes at the close of the conversation.

"The S. M. (or E. C.) if seated, does not rise to acknowledge a salute, and the H. P. (or P.), in robes, salutes and acknowledges salutes by bowing ceremoniously.

"An officer should always have his sword drawn when giving a command" to Knights under arms.

164. Only the presiding officer may salute sitting, except as herein provided.

Sir Knights seated in open conveyances, passing in review, will rise, face the reviewing officer and salute with the hand. If the conveyance is closed they will sit at attention, execute eyes right (left) and salute with the hand. Inattention, slouching or smoking when passing in review, or on parade is inexcusable.

165. The Grand Master, the Grand Commander, and their representatives, and Past Grand Commanders, are the only Sir Knights entitled to be received under an arch of steel.

166. Sir Knights should exchange salutes, the Knight or officer junior in rank saluting first.

Officers and Knights, covered or uncovered, but not in formation, without swords or with sword in scabbard, salute with the hand salute, holding the hand to the chapeau or cap until the salute is acknowledged or the officer passed.

At no time—no place—or under any circumstances, is a sword drawn to acknowledge a salute already given.

When in ranks Knights never uncover or salute except by command. Never salute and uncover at same time.

An officer is "in formation," but never is "in ranks."

A Knight in ranks will not salute when directly addressed but will come to attention if at rest or at ease.

If two commanderies or subdivisions meet, their commanders will exchange salutes, both commands being at attention.

When passing in review an officer salutes, executing eyes right, and looks toward the reviewing officer when he is six paces from him; and returns to the carry and turns the head and eyes to the front when he has passed six paces beyond him.

The Commander, if seated, acknowledges a salute with the hand, without rising.

Officers and Knights, in replying to a question from the Commander or other superior, rise and salute. The title of the Commander or other superior should not be given with the salute.

The Prelate, when in uniform, salutes the same as other officers; if in robes, he salutes and acknowledges a salute by bowing ceremoniously.

During the opening, closing, and other ceremonies in the Asylum, and on field ceremonies, all officers taking part will draw and return sword at the proper time without command.

167. All Sir Knights not in formation passing the uncovered National Flag, or when the National Flag passes, will render honor as follows: If in uniform and sword drawn they will salute with the sword; if in uniform and covered, or if in civilian dress and covered, they will uncover, holding the head dress on the right shoulder with the left hand; if uncovered, they will salute with the hand salute.

All hand salutes are given with the right hand.

Every National Flag in a passing Templar parade will be saluted.

No honors are paid when on route marches.

No salutes are rendered when marching in double time.

A mounted Sir Knight dismounts before addressing an officer not mounted.

A mounted officer dismounts before addressing a superior officer not mounted.

When several officers in company are saluted, all who are entitled to the salute return it.

OFFICIAL KNIGHT TEMPLAR HONORS

168. The honors to be paid by Templars, beyond true knightly courtesy, are such as are due to the official position held by such officers.

The Grand Master is saluted with the highest honors; all standards and banners dropping, officers and Sir Knights saluting, bands, trumpets, or field music, sounding "Presidents' March."

The Deputy Grand Master is received with standards and banners dropping, officers and Sir Knights saluting, bands, trumpets, or field music, sounding "General's March."

All other officers of the Grand Encampment, and a Grand Commander, within his own grand jurisdiction, are received with standards and banners dropping, officers and Sir Knights saluting, trumpets sounding three flourishes.

A Grand Commander, outside of his own grand jurisdiction, is received with standards and banners dropping, officers and Sir Knights saluting, trumpets sounding two flourishes.

A Deputy Grand Commander, the Grand Generalissimo, the Grand Captain General and Past Grand Commanders, within their own grand jurisdictions, are received with standards and banners dropping, officers and Sir Knights saluting, trumpets sounding two flourishes. Outside of their own grand jurisdiction they are entitled to but one flourish.

All other grand officers, within their own grand jurisdictions, are received with standards and banners dropping, officers and Sir Knights saluting, trumpets sounding one flourish. Outside their own grand jurisdiction the flourish is omitted.

An Eminent Commander is saluted by his own commandery with standards and banners dropping, officers and

Knights saluting, trumpets sounding one flourish. Outside of his own commandery he is not entitled to the flourish. The officer commanding a battalion is entitled to the same salute.

ESCORT OF THE COLOR

169. This ceremony, while most suitable for the formation of a grand commandery, may be used by a commandery, or by several commanderies in battalion or regimental formation. If several commanderies are present the colors should be massed. See Public Parade, Par. 147.

Selection as escort is a mark of special distinction usually accorded to a company or commandery for proficiency in drill and appearance. The commandery or larger organization being in line, with space reserved for the Standard Guard, the commanding officer details a platoon, company or commandery, to escort the Colors to their place in line.

The escort is formed in column of platoons, or if a platoon, in column of sections, the band in front. The escort then marches, without music, to the temporary station of the Standard Guard, which should be near the right flank of the line, and forms line, facing the Standard Guard, the band on the right, and presents swords; the band gives the ruffle and the field music, if present, sounds to the color.

Swords are brought to the carry, and column of platoons formed, the band taking post in front of the column; the Standard Guard places itself between the platoons, the escort marches with guide left, the band playing, and is so conducted that when the escort arrives at fifty paces in front of the line, the direction of the march shall be parallel to its front; when the Standard Guard arrives opposite its place in line, the escort is formed in line to the left; the Standard Guard passing between the platoons, advances and halts twelve paces in front of the commanding officer.

NOTE—If numbers are small or space inadequate the distances specified should be proportionately reduced.

The Standard Guard having halted, the commanding officer, who has taken post thirty paces in front of the center

of the line, faces about, commands: 1. Present, 2. SWORDS, resumes his front and salutes; the color bearers, State Color, if present, and Beauceant execute the color salute at the command **present swords**.

The commanding officer then faces about and brings the command to carry swords; at which the standard Guard takes its post in line; passing by the left of the commanding officer.

The escort presents swords and comes to the carry with the command, after which it is formed again in column of platoons, and, preceded by the band, marches to its place in line, passing around the left flank of the line.

The band plays until the escort passes the left of the line, when it ceases playing and returns to its post on the right, passing in rear of the line.

The command may be brought to a rest when the escort passes the left of the line.

DRILL CORPS AND COMPETITIONS

170. Nothing contributes more to the interest and esprit of a commandery, than a thoroughly competent and well supported drill corps. Competitions increase interest and efficiency only when conducted according to the highest standards of Knightly courtesy and true sportsmanship. The following suggestions for adoption by commanderies and grand commanderies are made for the information and encouragement of all concerned.

A drill corps should be formed in every commandery for training in drill and ceremonies, the inculcation of discipline, and general improvement in the action and life of the commandery. While the drill corps must develop independence of action and initiative, it should always be under the control of the commandery. Its officers may be appointed by the Commander or by the Council, or elected by the members of the corps, but must be selected with the greatest care, and be always subordinate to the authority of the commandery.

The Commander of the corps, who occupies the position of "Commander" in these regulations, is by far the most important. If not the author, he is indeed the inspiration and builder of the corps. Every commandery should endeavor to develop a man of the requisite qualifications, and should give him every possible encouragement and support. Only results count, and when obtained, the leader should not be disturbed in his tenure nor hampered in his plans.

The same may be said, only in lesser degree, of the other officers, junior officers and Knights, who are willing to perform the necessary sacrifice and labor, and to whom should be assigned the most effective positions, with the greatest possible permanency, and the largest measure of appreciation and support.

In cities and districts having several contiguous commanderies, the organization of permanent battalions and regiments should be encouraged.

Competitive Drills

171. The **Schedule Plan** provides for a specific schedule of movements to be placed in the hands of the Captain, by the drill committee, not more than thirty minutes prior to the appearance of his drill corps on the field; that all the required movements shall be taken from the drill regulations of the Grand Encampment, Knights Templar of America; that the schedule shall be known only to the committee, and that no Captain may witness the drill of any preceding team.

NOTE—As an encouragement to entry, it is also permissible when the schedule plan is used, to publish the schedule in advance, to facilitate the preparation of competitors. For Grand Commanderies, this is generally recommended.

172. The **Program Plan** does not prescribe a list of movements, but furnishes a program showing the class and value of movements which will be judged; as "Alignments, fifteen points," "Wheelings, fifteen points," "Sword manual, ten points," "Facings, five points," etc., which is published with the announcement of the competition. Experience proves that by this plan it is possible for a drill corps to perfect and memorize a schedule containing the required points, and execute the same faultlessly, without possessing either experience or a high degree of proficiency or general knowledge of the drill regulations.

The conclusion reached therefore, is that while the program plan may afford encouragement to beginners, the schedule plan is the only real test of all round efficiency in drill, and should be applied in all higher class contests and particularly for national competitions such as occur at the Triennial Conclaves of the Grand Encampment.

Judges

173. The question frequently arises concerning the relative advantage of Knights Templar or professional soldiers, as judges; the latter being frequently preferred because of their exact knowledge of drill, and because disinterested and impartial. Modern military science tends constantly to increase the importance of extended order and training for

combat, as compared with the close order drill, upon which all Knights Templar formations are based. With these close order formations as well as with the significance and historical value of our commandery display movements, and our peculiar uniform and equipment, Knights Templar, many of whom have army training, are constantly familiar; certainly no question can be raised of a lack of ability, or character, or sportsmanship on the part of Templars. It is, therefore, recommended that Templar judges be habitually employed in all competitions of the Order.

RULES FOR COMPETITIVE DRILLS

Preamble

174. The object of drill competitions is to create enthusiasm in the Templar body and perfect Knights Templar drill, without which the Order cannot make a creditable appearance in public.

It is believed the competitions of the Grand Encampment should be conducted under a plan which will fully test the proficiency of those participating, particularly the officers, who should be trained to think and act quickly, and that a specific numbered schedule given out shortly before the competition, will best accomplish this.

The schedule should never contain "catch commands" and usually only the fundamental and symbolic formations and movements; the preparation of contestants being facilitated by the elimination of all other paragraphs by the orders and rules of the competition.

The Grand Master for Triennial Conclaves and the Grand Commanders of the several states for State Conclaves, may if desired, create second and third classes with simpler schedules, or for such classes, schedules may be published in advance.

The following rules are deemed effective in producing the proper results and are intended for Class One Competitions. These rules may be modified to suit the convenience of any commandery or grand commandery, but when adopted by the Grand Encampment for its competitive drills, they

cannot be altered or amended except by action of that body, or in the interim, by order of the Grand Master.

Rules

175. 1. Each commandery drill team shall consist of twenty-four Knights, four guides, two platoon leaders, and one commander, total thirty-one; formed in two platoons.

Each battalion team shall consist of not less than three nor more than four companies of thirty-one men each, a standard guard, one battalion commander, one battalion adjutant, one sergeant major, and one bugler.

If desired the military title of officers may be temporarily assumed by drill teams as "Major," "Captain," "Lieutenant." For the assistance of the judges, arm bands may be worn to indicate the rank of officers and guides, as "Capt.," "1st Lt.," "2nd Lt.," "1st guide," "2nd guide," "3rd guide," "4th guide." Bands to be made of white cloth with black letters, and may be furnished by the general committee and worn interchangeably by the commanderies when on the field.

Movements in the schedule shall be taken from and be in accordance with the Drill Regulations of the Grand Encampment of the United States of America, eliminating paragraphs number -----

2. Only members of the organization in good standing, shall participate in competitive drills, and each commanding officer upon reporting for drill shall hand to the first judge a certificate as follows: "I certify upon honor that each Sir Knight in my command is a member in good standing of ----- Commandery, No. -----, State of -----, and that each individual participated in the general street parade ----- (give date). (The name, number of the commandery and state to be specified.) The form for which to be supplied by the committee.

3. Drill schedules will be specific numbered movements described in the Drill Regulations of the Grand Encampment of the United States of America. Commanding officers will give the proper tactical commands. Movements must be exe-

cuted as described in the paragraph to which related, see Par. 10a. General rules govern always, unless otherwise provided. Each marching movement must be continued a sufficient distance to give a complete demonstration and to permit proper scoring. Unnecessary commands will be penalized. Sword Manual to consist of not less than eight movements. (To be specified.) All drills without music.

4. Schedule of drills may be printed on cardboard of sufficient weight to permit of handling on the field and of scoring thereon by the judges, to be about 3½ by 6½ inches with margin for noting errors, to contain necessary data and the sheets to be bound or tied loosely at top or otherwise arranged for convenient use; or separate Judges' Score Cards, as hereinafter shown, may be used.

5. Each team shall report thirty minutes before their time of going on the field, at which time the Commander will be handed the schedule to be drilled. No Commander of any team will be permitted to witness the drill of competitors preceding his time for drill, nor any team to hold any practice drill after the competition begins. The principle herein involved is a matter of honor and sportsmanship.

6. The drill schedule and plans for the Triennial competition shall be made by a general committee of three Knights Templar chosen by the Grand Master for their eminent proficiency in drill and knowledge of Knights Templar tactics. They shall co-operate with the local drill committee concerning the program, all arrangements to be approved by the Grand Master. The general committee shall also suggest names to the Grand Master for selection as judges. They shall also total, average, and announce the result of the scores to be handed them by the judges at the completion of the drill of each team, and distribute the prizes under the direction of the Grand Master.

7. The uniform shall be full dress. After reporting to the judges, each team will be inspected, following immediately with drill schedule. Inspection of uniforms will apply only to neatness, cleanliness, and agreement with the uniform regulations of the Grand Commandery to which belonging. Newness of uniforms will not be taken into con-

sideration, although they must not be worn or frayed. Time for company drills not to exceed thirty minutes, for battalion drills forty-five minutes, to be determined by the general committee, not including time of inspection.

8. Penalty for errors shall be as follows: Knights one; guides, sergeant majors and buglers two; platoon leaders three; commanders four; battalion commanders five. Battalion adjutants to rank as commanders. Penalty for omission of any part of the schedule to be the proper percentage of each movement omitted, to possible total. Each movement in the schedule to be drilled in the order given. A movement passed cannot be later taken up and therefore, will count as an omission. Penalty for overtime, for the first minute or major fraction, five points, and ten points for each additional minute or major fraction. Unnecessary or wrong commands will be errors.

9. The cadence and step of each team shall be taken at least three different times by one of the judges, in periods of not less than thirty seconds, and deduction of one point made for each step over or under the specified cadence and for each inch over or under the specified length, as averaged for each test, for the full step, side step, back step or double time.

10. Every individual of each organization entered in competitive drill, must participate in the general street parade given at all conclaves in order to be eligible to participate in the competitive drill.

11. The order in which teams drill shall be decided by lot under the direction of the general committee, and cannot be changed except as hereafter provided (See Rule 12).

12. All rules and regulations governing the drills must be strictly adhered to and no variation will be permitted except in case of some unforeseen emergency and then only by unanimous consent of the Commanders of the teams entered in the competition.

13. There shall be not less than three nor more than five judges, all Knights Templar, selected because of their

knowledge of and proficiency in Knights Templar drill and tactics, to be chosen as follows:

Triennial Conclaves, the judges to be selected by the Grand Master as he may elect, providing that the general committee shall be expected to recommend to him names for appointment.

State Conclaves, the Grand Commander shall appoint the general committee and judges, who shall be Knights Templar with the same qualifications and duties as above stated.

14. The highest award of merit to be given by the Grand Encampment, for proficiency in drill, shall be, for the first prize, a golden band of metal to be attached to the staff of the commandery Beauceant, inscribed with full data of the occasion. A silver band similarly inscribed shall be awarded as second prize, and bands of bronze for the third, fourth and fifth prizes.

In addition there shall also be given, under the authority of the Grand Encampment, to each of the first five contestants, a white streamer or pennant, on which shall be printed a suitable inscription defining the awards, the same to be attached to the commandery Beauceant.

These awards shall not be construed to prevent or discourage the usual presentation of trophies by local committees.

Scoring

176. While any desired plan for judging and scoring may be adopted, the following scheme is recommended as being accurate, rapid and workable:

(a) Definition of duties of judges:

The first judge will observe and mark the errors of the Commander, his position, wrong commands, unnecessary commands, and general alignments.

The second judge the platoon leaders and omissions.

The third judge the Knights and guides of the first platoon.

The fourth judge the Knights and guides of the second platoon.

The fifth judge the cadence, length of step and time.

On inspection the first judge receives honors, inspects swords, baldrics, gloves, chapeaux, faces, collars, the sword movement and the general appearance of the commandery.

The second judge inspects coats, belts, trousers, shoes, and position of the Knight.

In battalion competitions the first judge will mark the battalion commander, adjutant, sergeant major, bugler and battalion alignments and omissions.

Each of the other four judges as assigned by the first judge, will score and mark one company throughout the inspection and drill. Should one judge be unassigned he will mark the cadence, length of step and time.

(b) The scoring will be based on a total of 1000 points.

(c) Should it be desired for any reason to give a higher rating the possible total may be increased to 1500 or 2000, or the total of the cuts may be divided by two or any other divisor, and the quotient subtracted.

(d) In battalion competitions the average of the commanderies (companies) should be subtracted. This will be obtained by dividing the sum scored against all the commanderies by the number of commanderies in the battalion. This same rule of averages might also be applied to platoons in commandery (company) competitions. It will be observed that these methods of increasing scores would not affect the relative standing of the contestants.

(e) Each Commander should be furnished a summary of the score of his team, showing the markings in detail.

(f) For state competitions a lesser number of judges may be employed if desired. It will always be important that the duties of the judges and the accountant be assigned in advance to admit of thorough preparation. The names of the judges should not be announced before the commencement of the competition.

(g) The schedule should be printed, preferably on both sides of a small card, in form convenient for use by Commanders and Judges.

(h) Score cards are here illustrated. A convenient size for the judge's cards is 3½ by 5½, for the summary, 5½ by 6 inches.

1st Judge—Score Card

-----Commandery No.-----

Inspection -----	-----
Commander-----	-----
Position (4) -----	-----
Wrong Commands (4)-----	-----
Unnecessary Commands (4)-----	-----
General Alignments -----	-----
Total deductions -----	-----

On inspection the 1st Judge receives honors, inspects swords, baldrics, gloves, chapeaux, faces, collars, the sword movement, and general appearance. Will penalize errors in general alignments, at the moment of completion, in all movements involving the whole command, which platoon judges will not mark.

(Signed)-----Judge
Date-----

3d or 4th Judge—Score Card

-----Commandery No.-----

Knights and Guides of-----Platoon

Sword Manual (1)-----	-----
Movements (1) -----	-----
Guides (2) -----	-----

Will mark errors of guides of threes, sections and platoons, in position, distance, trace and direction.

(Signed)-----Judge
Date-----

2d Judge—Score Card

-----Commandery No.-----

Inspection -----	-----
Platoon Leaders (3)-----	-----
Omissions -----	-----
Total deductions -----	-----

On inspection the 2d Judge inspects coats, belts, trousers, shoes, and position of the Knight.

(Signed)-----Judge
Date-----

5th Judge—Score Card

-----Commandery No.-----

Cadence	1	2	3	4	-----
Length of Step	1	2	3	4	-----
Time from	-----to-----net				
Total	-----				

For every step over or under the required cadence, or more or less than the required length, 1 point; for the first minute or major fraction over time, 5 points, and for each additional minute or major fraction, 10 points.

(Signed)-----Judge
Date-----

COMPETITIVE DRILLS

Recapitulation		Perfect Score	1000
-----Commandery No.-----		Deductions	-----
Deductions for:		Net Score	-----
Inspection -----		(Signed)-----	Accountant
Commander, position -----		Date-----	192--
Unnecessary Commands -----			
Wrong Commands -----			
Allignments -----			
Platoon Leaders -----			
Guides -----			
Knights -----			
Cadence -----			
Length of Step -----			
Omissions -----			
Time -----			
Total -----			

The Program Plan

177. If the Program Plan is adopted the same rules and procedure is applicable with the following exceptions.

Since each team decides for itself the movements to be executed, all reference to "Schedule" will be omitted. This will require the elimination of rules five and six and the modification of rules one, three, four and eight.

The number and function of the judges need not be changed, nor the method of marking, which will be based on the following valuations:

General appearance -----	15	points
Marching -----	15	points
Alignment -----	15	points
Wheelings -----	15	points
Sword Manual -----	10	points
Facings -----	5	points
Flank Movements -----	5	points
Oblique Movements -----	5	points
Templar Display -----	15	points

Total -----100 points

SCHOOL OF THE COMMANDERY AND
PLATOON

General Rules

178. The commandery, platoon or detachment is habitually formed in single rank. Par. 189.

For special occasions and formations, fours or twos may be used, but the unit of threes is enjoined by these regulations, and is always recommended.

The Commander is responsible for the instruction of his officers and junior officers not only in the duties of their respective grades but in those of the next higher grades; but while giving them thorough instruction in the methods of training and command, he must be careful not to curtail their initiative.

The commandery will be divided into platoons usually of not less than two or more than four sections each, equal in strength unless the left platoon is smaller. Companies may be formed of not less than two platoons each, which will generally be determined by the number of available officers. Within these limits the permanency of platoons and companies should be maintained.

The formations of the commandery are: line, column of companies or platoons (at full distance or in close column), line of companies or platoons, (at full or close intervals), and column of threes or sections.

At the formation of the commandery, the platoons are numbered consecutively from right to left and these designations do not change. Officers and junior officers will be assigned as company and platoon leaders, and guides. A commandery of less than four sections may be commanded by the Commander as a single platoon.

179. When numbers and space permits, the column of sections or platoons in preference to threes should always be formed for review, both in and out of the Asylum, and for street parades and other public ceremonies, as being more

dignified, impressive and characteristic. The column of sections may also very properly be made the route formation of the commandery.

180. The descriptions and plates in these regulations, in answer to the requirements of highly specialized drill, provide for right and left guides of each platoon. When limited, however, by lack of numbers or skill, it is permissible for a commandery to omit interior guides or the guides entirely, employing the second and third officers alternately as guides and platoon leaders. Interior Guides may even be omitted from competitive drills, when so provided by the rules of the competition. The commandery or company in line, interior guides will be in the line of file closers, opposite the second file from the left and right of their respective platoons.

The right and left guides of the flank platoons will be respectively the right and left guides of the commandery or company.

181. As instructor, the Commander goes wherever his presence is necessary. In line, his post is three paces in front of the center of the commandery; in column of files, twos, threes, and sections, by the side of the leading guide, on the flank opposite the file closers; in column of platoons or companies, three paces in front of the chief of the leading subdivision; in line of platoons or companies, in column of threes or sections, three paces in front of the leading guides and opposite the center of the interval between the leading subdivisions.

At the command to dress, unless otherwise provided, the commander or platoon leader places himself in prolongation of the line, two paces from and facing the flank toward which the dress is made, verifies the alignment, commands front and takes his post.

182. Chiefs of platoons are posted as follows: (a) In line, in the line of file closers two paces in rear of their respective platoons; (b) the commandery in column of files, twos, threes, or sections, in the line of file closers two paces opposite the center of their platoons; (c) in column of

platoons, two paces in front of their platoons; (d) in line of platoons, by the side of the leading guide.

The Standard Guard

183. In these Regulations, while no provision is made for the Standard Guard in the drill and display movements of the commandery, it may be used if desired and when present, will take position and maneuver as indicated in the text, or as may be determined by the commanding officer. See "Formation for Public Parade," Par. 147.

The Standard Guard is composed of the Standard Bearer, Sword Bearer, Warder, and Color Bearer, if present, any or all of whom may be replaced by temporary detail, when exigency requires. The Sword Bearer commands the Standard Guard, marches on its right, and does not carry a banner. When the state color is present it will be borne by an extra color bearer, who will march on the left of the Standard Bearer.

NOTE—Since it is the duty of the Standard Bearer to "Display the banner of our Order," and since the National Flag must always be on the right, it is suggested that a Color Bearer be detailed to carry the National Flag. In some jurisdictions the State Flag is also carried, although not authorized by the Grand Encampment nor recognized by the Ritual. When carried it should be on the left of the Standard Bearer and by an extra Color Bearer. The military and ceremonial functions of the Standard Guard will be best fulfilled if the Warder does not carry a banner. The formation of the Standard Guard would then be, a front of four (or five), from right to left; Sword Bearer, in command; Color Bearer with National Flag; Standard Bearer, with Beauceant or Grand Standard; Extra Color Bearer with State Color, if present; Warder. Should the Warder carry the National Flag he should march on the right of the Standard Bearer.

Sir Knights bearing flags or banners may lay aside the sword, or if carried it should be in scabbard, hooked up. Par. 83.

The Platoon

184. The platoon usually consists of not less than twelve files, commanded by an officer or junior officer, designated as platoon leader. When composed of not less than twenty-four files, a company of two platoons may be formed commanded by an officer or junior officer designated as company leader.

Right and left guides of the platoon should be designated from the junior officers; if no guides are present the flank files of the platoon act as guides.

The alignments are executed as prescribed in the school of the squad, the guide being established instead of the flank file.

When platoons are to be dressed, platoon leaders give commands and place themselves as follows: The commandery or company in line he gives the command dress and takes his post; in column of platoons he places himself two paces from and facing the flank toward which the dress is made, and after dressing his platoon, commands front, and takes his post.

Platoon leaders repeat such preparatory commands as are to be immediately executed by their platoons, as **forward, threes or sections right, etc.**, the Knights execute the commands **march, halt, etc.**, if applying to their platoons, when given by the commander. In movements executed in route step or at ease the platoon leaders repeat the command of execution if necessary. Platoon leaders do not repeat the commander's commands in executing the manual of the sword, nor those commands or parts of commands which are not essential to the execution of a movement by their platoons, as, **column of threes, first platoon threes right, etc.** In giving commands or cautions, platoon leaders may prefix the number of their platoons, as **First platoon, halt; Second platoon, threes right, etc.**

When the formation admits of the simultaneous execution of movements by platoons, the commander may cause such movement to be executed by prefixing, platoons to the command prescribed, as, 1. **Platoons Right front into line,** 2.

MARCH. To complete such movements the commands halt or march are given by the commander. When separately formed the command front is given by the platoon leader.

185. The commandery, company or platoon in column of sections, threes, twos or files, forms column and reforms subdivisions as explained in the school of the squad and school of the commandery; also executes the halt, rests, facings, steps and marchings, manual of the sword, resumes attention, kneels and rises as explained in the school of the squad; and executes threes or sections right (left), threes or sections right (left) about, route step, and at ease, and obliques and resumes the direct march as explained in the school of the squad and school of the commandery. The same rule applies to detachments, escorts, etc., substituting their designation in the commands.

186. When interior guides are not present, wheeling from line into column of platoons, the rear guide will pass to the opposite flank and follow in trace of the leading guide. Wheeling into line from column of platoons, he will pass so as to be in his post on completion of the wheel. In passing he moves in front of his platoon or by the shortest route, in double time.

In all wheels, the guide on the marching flank keeps the pivot constantly in view; to this end, the Knight next to him keeps the line of his shoulders a little to the rear, but in the same direction.

In wheeling on a fixed pivot, when the subdivisions are halted, the command halt is given when the marching flank is about three paces from the perpendicular to the original position.

In wheeling on a moving pivot, the command forward is given in sufficient time, to add march the instant the wheel is completed.

In all wheelings by threes or sections the forward march is taken up on the completion of the wheel unless the command halt is given.

In forming line from column of platoons, if the platoons are unequal, the guide should first be announced on the flank

toward which the wheel is made, and the alignment of the guides effected before the command **march** is given.

187. In computing distances the breadth of a Knight is taken at twenty-two inches, and his depth at twelve inches; this gives ten inches from breast to back (facing distance) between ranks in column of files, between ranks in column of twos, thirty-two inches, between ranks in column of threes, fifty-four inches, and between ranks in column of sections one hundred twenty inches.

The distance of the leading guide from the leading file, and the rear guide from the rear file, in column of files, is ten inches, in column of twos, thirty-two inches, in column of threes, fifty-four inches, and in column of sections, fifty-four inches.

188. The guides of a column of threes or sections place themselves on the flank opposite the file closers. To change the guides and file closers to the other flank: 1. File closers on left (right) flank, 2. **MARCH**; at the first command the file closers close to the column, and at the command **march**, they dart through; the commander and guides change to the other flank.

Guides and file closers will give such commands and cautions as may be necessary or as directed by the commander; this to apply to guides of all subdivisions.

In column of threes or sections each rank preserves the alignment toward the side of the guide.

In marching to the front the leading guide selects points in advance, observing with greatest care the direction, and the length and cadence of the step; the Knight next to the guide takes special pains never to pass him, keeping the line of his shoulders a little in rear but in the same direction.

Guides and Knights in the line of file closers, execute the sword manual during the drill, unless specially excused, when they remain at the carry. During ceremonies they execute all movements.

In taking intervals and distances, unless otherwise provided (see Par. 220-222), the guides at the first command, place themselves in the line of file closers. In taking inter-

LEGEND.



COMMANDER.



FIRST PLATOON LEADER



SECOND PLATOON LEADER



GUIDE



GUIDE OF THREES



KNIGHT

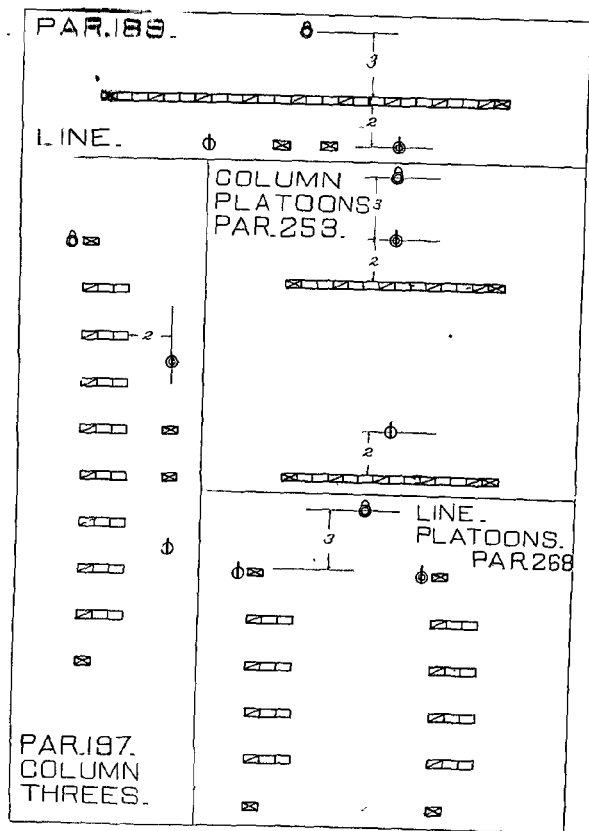

vals at the command march, the file closers face to the flank, and each steps off with the file nearest him. In assembling the guides and file closers resume their positions in line.

To Form the Commandery

189. At the sounding of the assembly, the Senior Warden (or senior junior officer, right guide) facing the proposed line of formation, and six paces in front of the center, commands: **Fall in**, at which the Knights form in single rank facing to the right, graduated in size from front to rear, tallest in front; the swords in scabbards.

The signal having ceased, he commands: 1. **Left**, 2. **FACE**, 3. **Sir Knights**, 4. **Draw**, 5. **SWORDS**.

If the roll is to be called, he first brings the commandery to **support**, and calls the roll. Each Knight answers "**here**", and brings his sword to a **carry**, as his name is called. He then commands: 1. **Count**, 2. **THREES**; at this command, all except the right file execute **eyes right**, and commencing at the right, the Knights count in a sharp, quick tone of voice, **one, two, three**, etc. Each Knight turns his head and eyes to the front as he counts. He then commands: 1. **Ones**, 2. **COUNT**. When the numbers one of each three, except the first, execute **eyes right** and count in the same manner, **one, two, three, four, etc.**, from right to left, and immediately turn the head to the front.

The odd threes constitute the right, and the even threes the left, of sections.

Unless otherwise designated by the commander, the left guide of each section will be its Chief. Chiefs of sections ascertain the relative position of their sections in line, when ones are counted. Each chief of section divides the number counted by his section by two; the quotient represents the number of his section: e. g., should his number be eleven, divided by two, the quotient five, tells him that five sections precede his own.

If the Standard Guard be present, see Par. 148-183.

Twos are then counted on the same principles, and, if the passion cross is to be formed, fours may be counted in the same manner.

He ~~then~~ divides the commandery into platoons; after which the left guide (Junior Warden) takes post on the left of the line.

The Commander takes post in front of the Commandery and at a distance about equal to one-half the line.

NOTE—For instruction and with inexperienced commandery, the Senior Warden may, if necessary, dress the commandery to the right before presenting it to the Commander, although the dress is not a part of the authorized formation.

The Senior Warden, being six paces in front of the center of the commandery, and facing it, commands: 1. **Present**, 2. **SWORDS**, faces about, salutes the Commander, and reports: **Eminent Sir, or, Sir, The Commandery is formed.** The Commander returns the salute with the hand, draws sword and commands: 1. **Carry**, 2. **SWORDS**.

The Senior Warden, without command, faces about and takes his post as right guide.

The platoon leaders now take their posts.

If numbers permit the formation of two or more companies of not less than two platoons each, and it is desired, this will now be done by the Commander, who will designate the necessary leaders and guides. Companies should be separately formed preparatory to the formation of the battalion. School of the Battalion, Par. 332.

NOTE—If space be inadequate to form large commanderies in line, platoons (divisions or companies) may be separately formed, their guides respectively reporting to the Senior Warden (right guide), **Sir, First (or such) platoon (division or company) is formed.** Such subdivisions may be formed in column of subdivisions or otherwise as convenient, and closed in mass to any required distance, thus obviating the use of the double rank, which is always awkward and unsuitable, especially for the sword manual, the wheelings and asylum ceremonies. See Par. 11.

190. Being in line at a halt, the Commander directs the Senior Warden to dismiss the commandery. The officers fall out, and the Senior Warden salutes, steps three paces to the front; faces to the left and commands:

1. **Sir Knights**, 2. **Return**, 3. **SWORDS**, 4. **DISMISSED**.

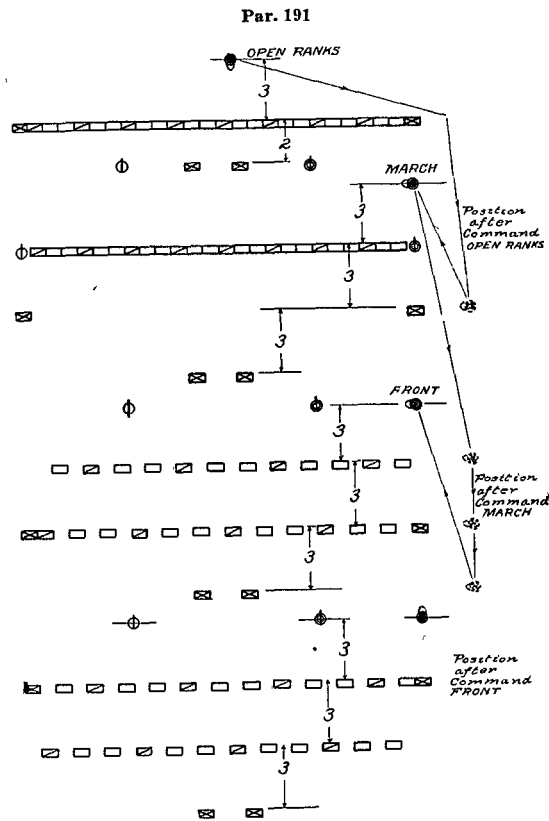

To Open Ranks

191. Being in line, at a halt: 1. Open ranks, 2. MARCH, 3. FRONT. At the first command the right and left guides step backward three paces (six back steps) to mark the new alignment of the rear rank; the platoon leaders place themselves on the right and left of the front rank; the other file closers step back three paces in rear of the line of guides (eight back steps); the Commander goes to the right flank, and sees that the guides are on a line parallel to the front rank, then places himself facing the left, three paces in front of the right file, and commands: march, at which command, the platoon leaders place themselves three paces in front of the centers of their respective platoons (by the shortest route); the front rank, the odd numbered Knights, dress to the right without closing intervals; the even numbered Knights who constitute the rear rank, cast their eyes to the right, step backward, halt a little in rear of the alignment, and then dress to the right without closing intervals, on the line established by the guides. The Commander superintends the alignment of the officers, and the front rank, and the right guide that of the rear rank; the Commander verifies the alignment of the rear rank and file closers, then places himself facing the left, three paces in front of the right file, gives the command front, and faces to the front.

At the command front, the guides resume their places in the front rank, and the Knights cast their eyes to the front. The officers and file closers cast their eyes to the front as soon as their alignment is verified.

To Close Ranks

192. Being at a halt: 1. Close Ranks, 2. MARCH.

At the command march, the platoon leaders face outward, and resume their places in line; the rear rank closes in quick time, each Knight resuming his place in line; the Commander takes his post.

To Wheel the Commandery

193. Being in line at a halt: 1. Left (right) wheel, 2. MARCH, 3. Commandery, 4. HALT, 5. Right (left), 6. DRESS, 7. FRONT.

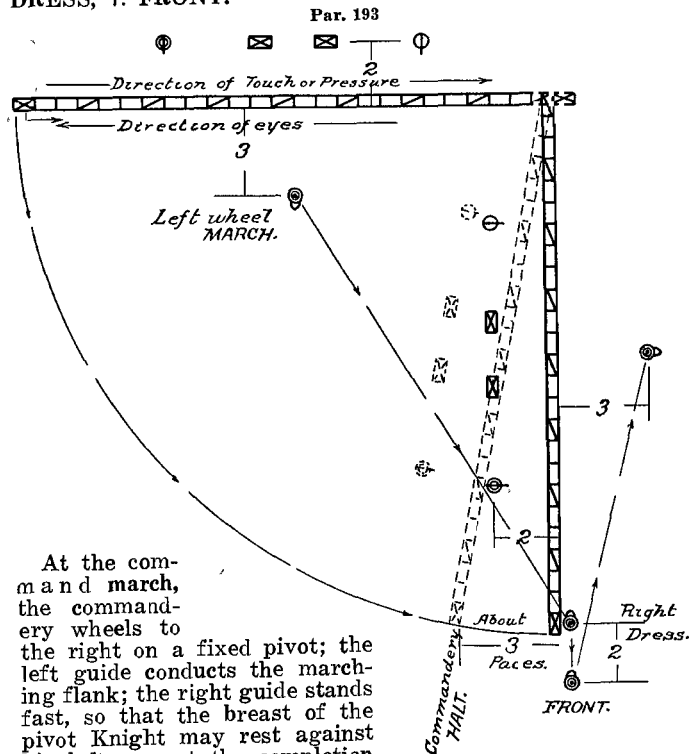

At the command march, the commandery wheels to the right on a fixed pivot; the left guide conducts the marching flank; the right guide stands fast, so that the breast of the pivot Knight may rest against his left arm at the completion of the wheel.

The Commander superintends the wheel, moves by the shortest line to a point commandery distance in front of the pivot, and faces to the late rear. The command halt is given when the left guide is about three paces from the perpendicular; the left guide advances quickly, and places himself lightly against the breast of the Commander, who establishes him on the line. At the command dress, Par. 194, the Knights dress up to the line of the pivot Knight and the left guide. At the command front, the right guide places himself on the right of the pivot.

To continue the march upon completion of the wheel: 3. Forward, 4. MARCH. The command forward is given when the left guide arrives at three paces from the perpendicular, the command march, the instant the wheel is completed. The right guide places himself beside the pivot, at the command forward.

To Change Direction

194. Marching in line: 1. Right (left) wheel, 2. MARCH, 3. Forward, 4. MARCH. At the command march, the commandery wheels to the right on a moving pivot; the command forward is given when the guide is at three paces from the perpendicular, and the fourth command, the instant the change of direction is complete.

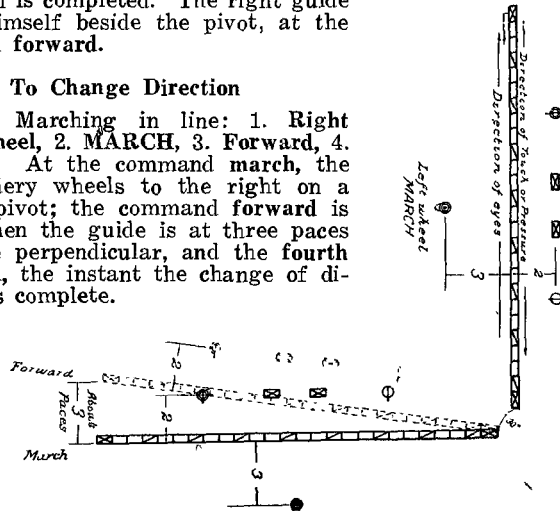

Par. 194

To Turn on a Fixed Pivot

195. Being in line: 1. Commandery (platoon or section) left (right), 2. MARCH, 3. Commandery, 4. HALT, or, 3. Forward, 4. MARCH.

Par. 195

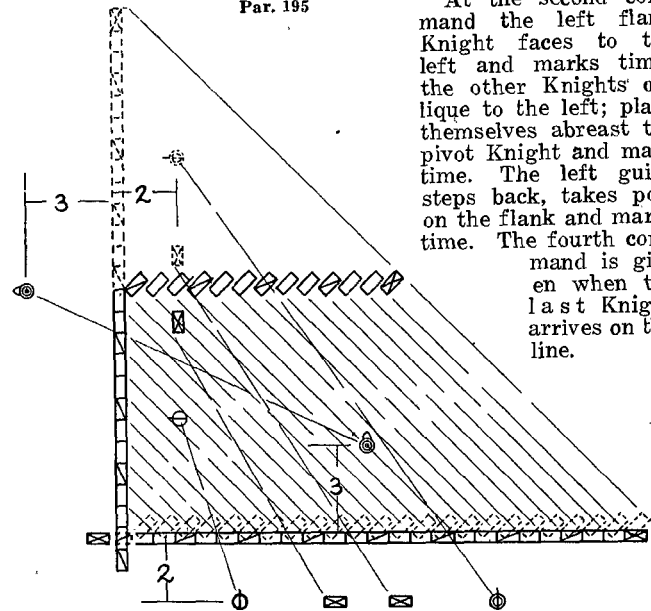

At the second command the left flank Knight faces to the left and marks time; the other Knights oblique to the left; place themselves abreast the pivot Knight and mark time. The left guide steps back, takes post on the flank and marks time. The fourth command is given when the last Knight arrives on the line.

The command halt may be given at any time after the movement begins; only those halt who are in the new position; each of the others halt upon arriving on the line, aligns himself to the left, and executes front without command.

To Turn on a Moving Pivot

196. Being in line: 1. Right (left) turn, 2. MARCH, 3. Forward, 4. MARCH.

At the second command the pivot Knight faces to the right in marching and takes the half step. The other Knights oblique to the right until opposite their places in line, then execute a second right oblique and take the half step on arriving abreast of the pivot Knight. The right guide pauses, turns to the right and conducts the marching pivot, see Par. 22; all take the full step as the last Knight arrives on the line, at the fourth command.

Right (left) half turn is executed in a similar manner; the pivot Knight making a half change of direction to the right or left, and the other Knights making quarter changes of direction in obliquing.

At the command halt, which may be given at any time after the movement begins, only those halt who are on the new alignment, the movement being completed as explained.

To Form Column to the Right or Left

197. Being in line: 1. Threes right (left), 2. MARCH.

At the command march, each three wheels to the right on a fixed pivot; upon the completion of the wheel the threes take the full step without further command, guiding to the left (marching flank). The guide of each three (the Knight on its left) preserves the distance of fifty-four inches from the three in his front (from breast to back). The right guide places himself fifty-four inches in front of the left file of the first three, and marches on a line parallel to the former

Par. 197

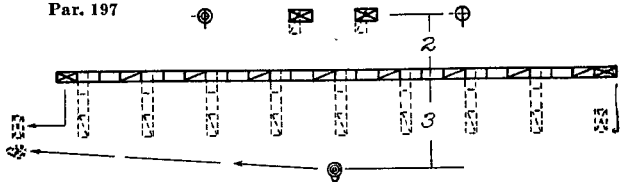

front of the commandery; the left guide follows at fifty-four inches in rear of the left file of the rear three; the file closers march at two paces from the flank of the column, on the side opposite to the guide, the platoon leaders opposite the centers of their respective platoons, the left guide of the first, and right guide of the second platoons are posted between the platoon leaders.

To form column of threes and halt: 1. Threes right (left), 2. MARCH, 3. Commandery, 4. HALT.

The fourth command is given the instant the threes complete the wheel.

To form column of sections is similarly executed, by the command: 1. Sections right (left) wheel, 2. MARCH.

To March in Column of Threes to the Front

198. Being in line: 1. Right (left) by threes, 2. MARCH.

At the command march, the right three moves straight

Position of Threes at
end of second step

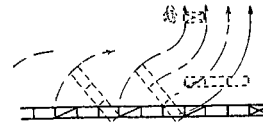

Par. 198

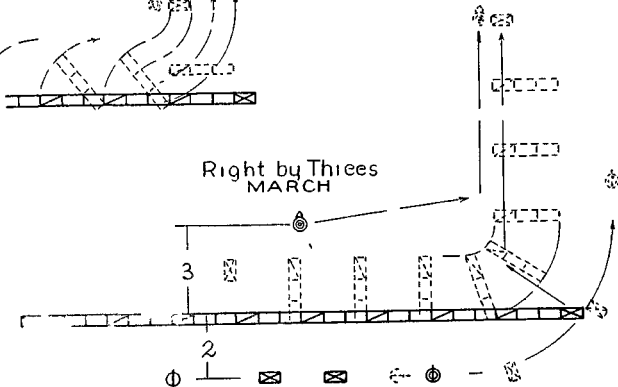

to the front, shortening the first three or four steps (half step), the right guide places himself in front of the left file

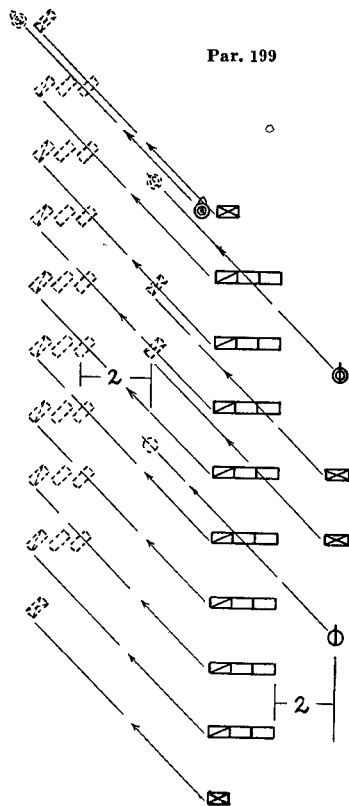

of the right three; the other threes wheel to the right on fixed pivots; the second three, when its wheel is two-thirds completed, wheels to the left on a moving pivot, and follows the first three; the other threes, having wheeled to the right, move forward and wheel to the left on moving pivots, on the same ground as the second three.

Column of sections may be similarly executed by the command, 1. **Right by Sections**, 2. **MARCH**. Section chiefs giving necessary commands.

To Oblique in Column

199. 1. **Left (right) oblique**, 2. **MARCH**.

During the oblique, the different subdivisions preserve their parallelism; the Knight in each rank, on the side toward which the oblique is made, is the guide of that rank. The leading guide is guide of the column when the oblique is toward his flank; when the oblique is toward the opposite flank, the guide of the leading subdivision is the guide of the column.

To resume the direct march: 1. **Forward**, 2. **MARCH**.

The guides, during the oblique, cover in trace parallel to the original direction.

If halted while obliquing, the swords being at a position other than carry, the Knights will, upon halting, bring their swords to a carry and halt faced to the front.

If the command mark time be given while obliquing, the oblique march will be resumed by the command: 1. **Oblique**, 2. **MARCH**.

To Change Direction in Column of Threes or Sections

200. Being in march: 1. **Column left (right)**, 2. **MARCH**.

The leading rank wheels on a moving pivot, the wheel being completed, the guide takes his position. The other ranks move forward and wheel on the same ground.

Column half right (left) is similarly executed.

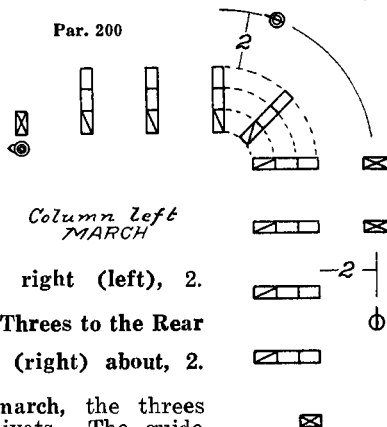

201. To put the column in march and change direction at the same time: 1. **Column right (left)**, 2. **MARCH**.

To March the Column of Threes to the Rear

202. 1. **Threes left (right) about**, 2. **MARCH**.

At the command march, the threes wheel about on fixed pivots. The guide at the head of the column faces to the left, and on the completion of the about, places himself in rear of the file on the marching flank of the rear three. The guide at the rear of the column faces to the left, and on the completion of the about, places himself in front of the file on the marching flank of the leading three. The file closers gain

space to the left or right, necessary to preserve the interval of two paces from the flank of the column. The Commander faces about, and hastens to place himself on the right of the guide, at the head of the commandery. In column, the about is executed toward the side opposite the file closers.

Par. 202

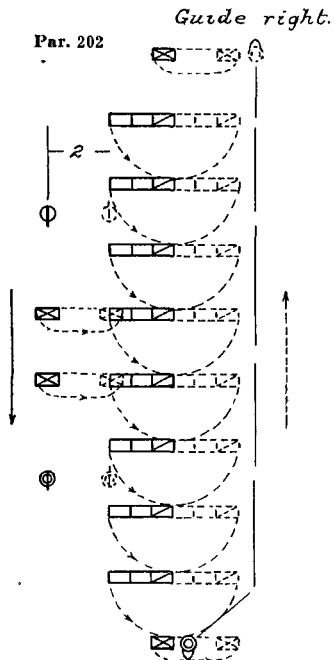

203. Being in line, to perfect the commandery in wheeling by threes or sections in circle, **1. Threes (sections) in circle, Right (left) wheel, 2. MARCH.**

The threes complete each arc of ninety degrees simultaneously. The principles of the fixed pivot are strictly enforced, the Knight on the marching flank taking the full step.

The threes having wheeled several times in circle: **1. Commandery, 2. HALT, or, 1. Forward, 2. MARCH.**

To Form Line from Column of Threes

204. **1. Threes left (right), 2. MARCH, 3. Guide right (left or center); or, 3. Commandery, 4. HALT.**

At the command march, the threes wheel to the left on fixed pivots. The guide, if in front of the pivot, faces to the left, placing himself on the right of the leading three upon the completion of

the wheel; if in front of the marching flank, he wheels to the left with the leading three, placing himself on the right of

the three as the wheel is completed; the guide in the rear places himself on the left of the commandery; the guide is announced the instant the threes unite in line.

Par. 204

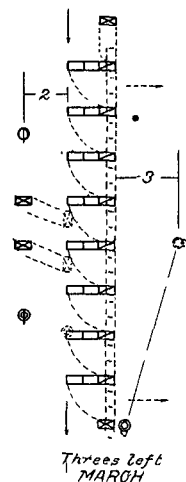

If the line be formed toward the side of the file closers, they close in to the flank of the column at the first command, and, at the command march, dart through the column.

To form line from column of sections, **1. Sections right (left) wheel, 2. MARCH, 3. Commandery, 4. HALT, or, 3. Forward, 4. MARCH.**

To Form Line on the Right or Left from Column of Threes or Sections

205. **1. On right (left) into line, 2. MARCH, 3. Commandery, 4. HALT, 5. FRONT.**

At the command march, the leading three wheels to the right on a moving pivot, and moves forward, aligning to the right, the guide places himself on its right to conduct it; each of the other threes marches a distance equal to its front beyond the wheeling point of the three next preceding, wheels to the right, and advances as explained for the first three; the rear guide places himself on the left when the rear three arrives on the line. Sections execute successively right (left) turn.

At the command halt, given when the leading three has advanced commandery distance in the new direction, it halts, and dresses to the right; the other threes halt and dress successively upon arriving in line. At the fifth command, given when the left three completes its alignment, all the Knights turn their eyes to the front. If the movement be executed toward the side of the guide, each file closer follows the three nearest him, passing in front of the following three.

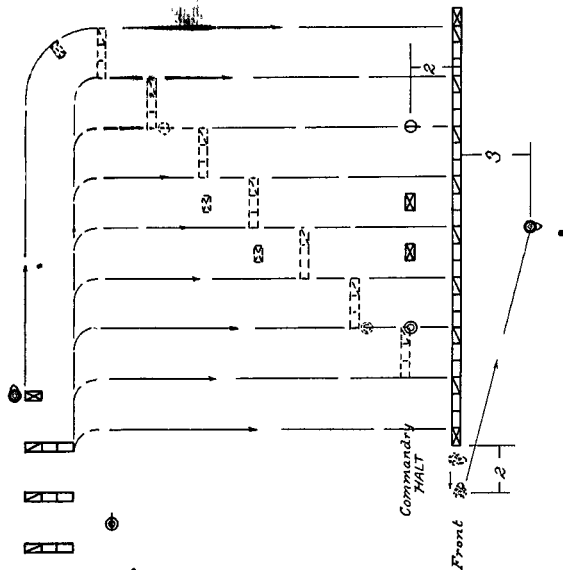

Par. 205

206. In these movements where it is prescribed that the leading subdivision moves commandery distance to the front and then halts, it may be halted at a less distance when necessary. This rule is general.

To Form Line to the Front From Column of Threes or Sections

207. 1. Left (right) front into line, 2. MARCH, 3. Commandery, 4. HALT, 5. FRONT.

At the command march, the first three moves straight to the front, aligning to the

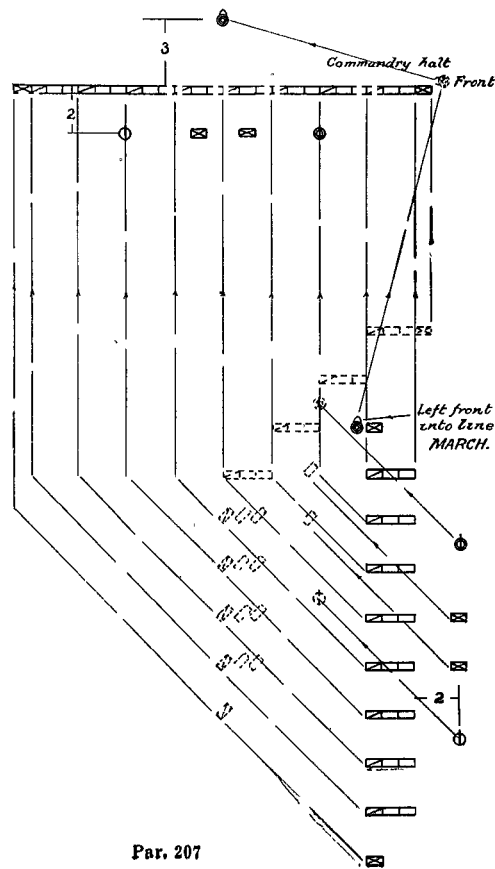

Par. 207

right on the leading guide, who places himself on its right flank; the other threes oblique to the left till opposite their places in line, when each in succession marches to the front.

At the command halt, given when the leading three has advanced commandery distance, it halts, and dresses to the right; the other threes halt, and dress to the right upon arriving in line.

The guide in rear places himself on the left of the front rank upon the arrival of the last three in line; the fifth command is given when the last three completes its alignment.

If the movement is made toward the side of the file closers, they dart through the column at the command march.

From column of sections in the same manner.

208. If marching in double time, or in quick time and the command be double time, the leading three moves to the front in quick time, the other threes oblique in double time, each taking the quick time, and former sword position, and dressing to the right upon arriving in line. This rule is general.

To March the Line to the Rear

209. 1. Threes right (left) about, 2. MARCH, 3. Commandery, 4. HALT; or, 3. Guide right (left).

At the command march, the threes wheel about on fixed pivots; the Commander passes through the nearest interval and places himself three paces in front of the center of the

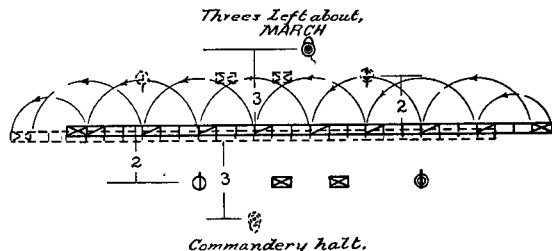

Par. 209

commandery; the guides wheel about on the arc of a small circle; the file closers dart through the nearest intervals.

To March a Few Paces to the Rear

210. Being at a halt: 1. About, 2. FACE, 3. Forward, 4. Guide right (left), 6. MARCH; or, if in march, by the commands: 1. To the rear, 2. MARCH, 3. guide right (left).

The file closers, upon facing about, maintain their relative positions.

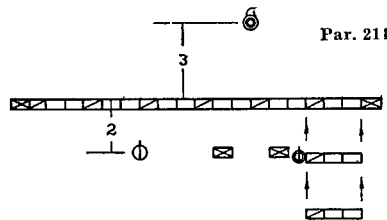

To Break Threes to the Rear

211. Marching in line, to pass obstacles: 1. (So many) threes from right (left) to rear, 2. MARCH.

At the command march, the designated threes execute left by threes on the three next on their left, which remains in line. When more than one three breaks to the rear, the Commander points with his sword to the inner three which leads the movement. The guide, when the threes are broken from his side, closes on the

threes which remain in line; if from the opposite side, the guide on that flank follows in rear of the three next to him.

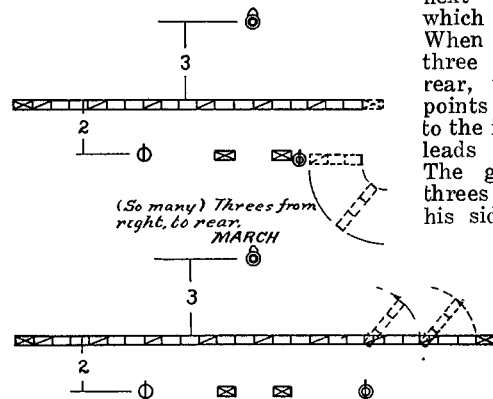

NOTE—The distance lost by the rear threes will be gained when the line is reformed.

212. Line is reformed by the commands: 1. **Rear threes right (left) front into line**, 2. **Double time**, 3. **MARCH**.

The guide, if on that flank from which the threes were broken to the rear, at the command march,

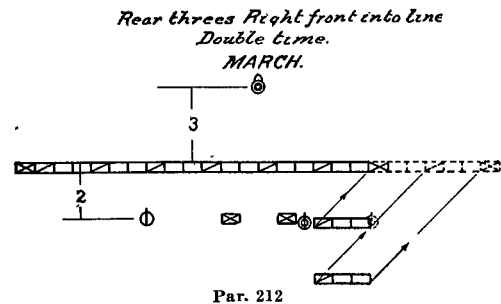

swords, Par. 115; on arriving in line the swords are restored to the former position without command.

213. Being in march: 1. **Route step**, 2. **MARCH**.

At the command march, the officers carry their swords at will or in scabbards; the Knights carry their swords at will; they are not required to preserve silence, or keep the step.

The column of threes is the habitual column of route, though any column of subdivisions may march in the route step, except column of files.

To resume the cadenced step: 1. **Commandery**, 2. **ATTENTION**. At the second command, the swords are brought to a carry, and the cadenced step is resumed. (The Commander or leading guide calls the cadence.) The commandery in line may also march in the route step.

The commandery in route step changes direction by the same commands as when in the cadenced step.

If halted when in route step the Knights come to rest.

214. To march at ease: 1. **At ease**, 2. **MARCH**. The commandery marches in route step, except that silence is preserved.

To resume the march at attention: 1. **Commandery**, 2. **ATTENTION**. If halted marching at ease, the Knights remain at ease. At ease may be taken from route step, and the reverse.

To Form Column of Files from Column of Threes

215. Being at a halt: 1. **Right (left) by file**, 2. **MARCH**.

At the command march, the right file of each three moves forward, the other files oblique to the right and follow the trace of the leading file, keeping closed to facing distance.

Column of files from column of twos, or sections, is similarly executed.

The guides precede and follow the leading and rear files. If marching, the leading file continues the march.

The Commander places himself on the left of the leading guide.

In forming column of files, the Commander commands: **Right (left) by file**, according as the right or left is in front.

NOTE—Whenever a marching column is broken into smaller subdivisions, as right by twos, right by threes, right by sections, etc., the flank which breaks to the rear need not mark time, provided the command march is given as that foot strikes the ground, toward which the oblique is made.

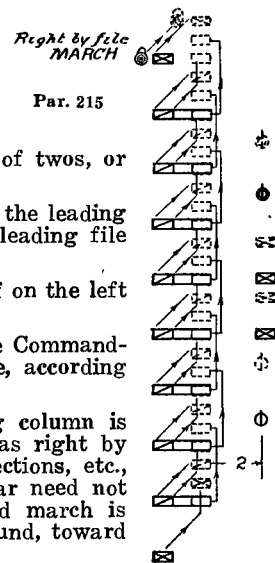

To Form Column of Threes from Column of Files

216. This movement is always executed away from the file closers. 1. Form threes left oblique, 2. MARCH, 3. Forward, 4. MARCH.

At the command march, the leading file of each three takes the half step; the other files oblique to the left, and place themselves successively on the left of the leading file and take the half step. The leading guide places himself in front of the left file of the leading three.

The fourth command is given when the last file arrives in line.

Column of twos (sections) from column of files is similarly executed.

To Form Column of Twos from Line

217. 1. Twos right (left), 2. MARCH.

The twos wheel to the right on fixed pivots as explained in Par. 197.

Line is formed from column of twos on the same principle.

To Form Column of Files from Line

218. Being at a halt: 1. Right (left), 2. FACE, 3. Forward, 4. MARCH; if in march; 1. By the right (left) flank, 2. MARCH.

The commandery having faced by the flank, the officers, guides, and file closers maintain their relative positions.

219. Line is formed by the commands:

1. Commandery, 2. HALT, 3. Left (right), 4. FACE; or 1. By the left (right) flank, 2. MARCH, 3. Guide right (left).

To Open Files to the Front

220. Being in line at a halt: 1. Front open files, 2. MARCH, 3. Guide right (left).

At the command march, the guides and number one in each three march straight to the front, carefully preserving the intervals; the numbers two take up the march on the third step, and the numbers three on the fifth step, counting from the command march. The second and third lines care-

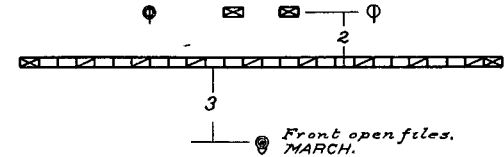

*Position at end of second step
Nº2 Knight moves forward on third step.*

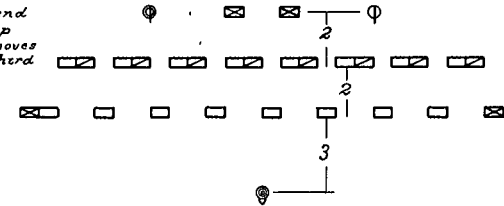

*Position at end of fifth step
Commandery moves forward on sixth step*

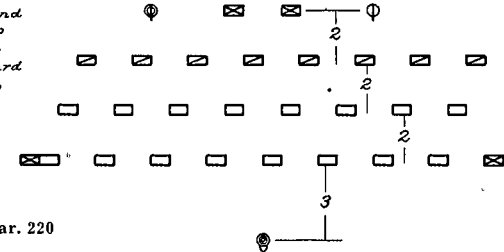

Par. 220

Guide right.

fully preserve their distances from the line in front, and each Knight marches opposite his place in line.

If the commandery be in march, the numbers one and guides continue the march, the others mark time and successively resume the march as just explained.

221. To reform line: 1. **Front into line**, 2. **MARCH**, 3. **Right (left)**, 4. **DRESS**, 5. **FRONT**.

At the command march, the leading line and guides halt; the others continue the march and successively halt upon arriving in line. The third line having halted, the Commander gives the remaining commands.

To Deploy by the Flank

222. Being in line at a halt: 1. **By the right (left) flank, take intervals**, 2. **MARCH**.

At the command march, the Knights face to the right, the guide taking up the march; the others successively take up the march on each alternate step, and carefully follow the trace of the guide, preserving a uniform distance from the file in front. When the left guide has his interval: 1. **Commandery**, 2. **HALT**, at which the Knights halt and face to the front.

Should the Commander wish to advance the line to the front without halting, he commands: 1. **By the left (right) flank**, 2. **MARCH**, 3. **Guide right (left or center)**.

223. To extend intervals: 1. **By the right (left) flank (to so many paces) extend intervals**, 2. **MARCH**, when the movement is executed on principles just explained.

224. The line may be deployed from both flanks at the same time, by the commands: 1. **By the right and left flanks, take intervals**, 2. **MARCH**.

To Close Intervals by the Flank

225. 1. **By the left (right) flank, close intervals**, 2. **MARCH**.

At the command march, the left guide stands fast; the others face to the left, and stepping out together, close upon the left guide, successively halt and face to the front.

226. To close intervals toward the center: 1. **On center, close intervals**, 2. **MARCH**.

At the command march, the left center Knight stands fast, the Knight bringing his sword to guide swords; the wings face toward the center and close intervals as previously explained; the guide resumes carry sword.

To Deploy Column of Threes in Open Order

227. Being in march: 1. **From the center**, 2. **Open order**, 3. **MARCH**, 4. **Guide right (left or center)**.

At the command march, the center file of each three marches straight to the front at the half step; numbers one

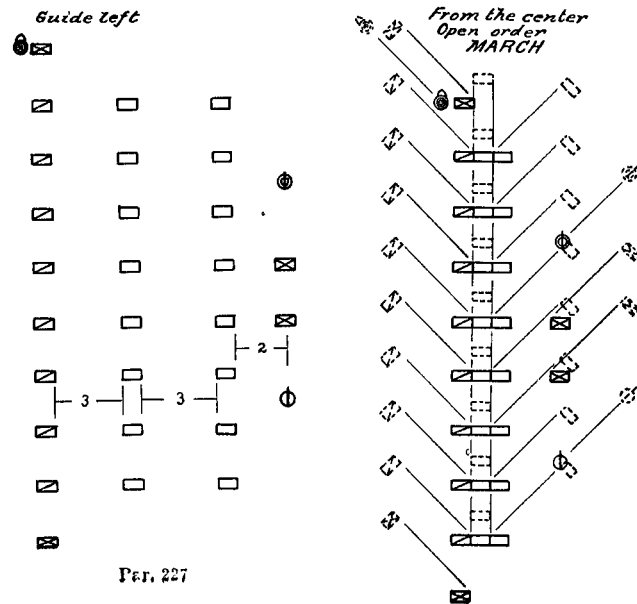

and three oblique to the right and left respectively, until each gains a distance of three paces from the center file, when they resume the forward march, the Commander giving the fourth command when all take the full step. The file closers remain on the flank of the column.

228. To march in close column again: 1. **Close order**, 2. **MARCH**, 3. **Guide left (right)**.

At the command **march**, numbers one and three oblique upon the center file which takes the half step; at the third command, all resume the full step.

To Countermarch the Column at Open Order

229. 1. **Files**, **Countermarch**, **column right (left)**, 2. **MARCH**.

At the command **march**, the leading guide countermarches to the right, shortening the step and describing a small circle, followed by the files in his rear, each of whom carefully preserves the trace; each of the other columns of files advances and countermarches abreast of the wheeling point of the leading guide.

The threes, being now reversed, are reformed by a repetition of the former commands.

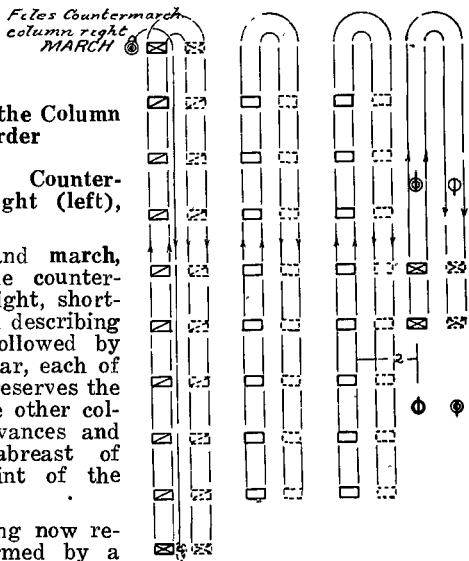

Par. 229

230. A column at open order, right in front, is countermarched right in front by the commands: 1. **Countermarch right in front**, 2. **MARCH**, 3. **Guide left (right or center)**.

At the command **march**, the center column of files countermarches to the right, shortening the step; the right column advances one pace, turns to the left, marches across the head of the center column, again turns to the left and marches to the former rear, passing inside of the left column; the left column advances two paces, turns to the right, marches across the head of the column, again turns to the right and marches to the former rear, passing outside of the right column.

The center column resumes the full step as soon as the flank files have regained their alignment, the Commander giving the third command. The file closers dart through the column at the second command.

To Form Line from Column of Threes by Two Movements

231. A part of the column of threes having changed direction to the right, to form line to the left: 1. **Threes left**,

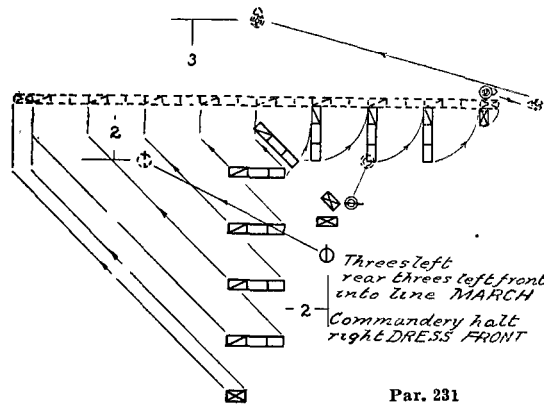

Par. 231

2. Rear threes left front into line, 3. MARCH, 4. Commandery, 5. HALT, 6. Right, 7. DRESS, 8. FRONT. Those threes having changed direction to the right, execute threes left at the command march; at the same time, the threes not having changed direction will execute left front into line.

The fifth command is given as the threes wheeling to the left unite in line; the rear threes successively halt, and at the seventh command dress upon the new alignment.

232. To form line to the right: 1. Threes right, 2. Rear threes left front into line faced to the rear, 3. MARCH, 4. Commandery, 5. HALT, 6. Left, 7. DRESS, 8. FRONT.

The threes which have changed direction wheel to the right, halt and dress to the left; the rear threes execute left front into line faced to the rear, the leading three obliquing to the left to obtain the necessary interval in which to execute the right about, Par. 241; the movement is completed as previously explained.

If the column has changed direction to the left, the line is formed by inverse commands and means.

To Wheel in Circles

233. Being in column of threes: 1. Threes in circle, left (right) wheel, 2. MARCH, 3. Guide left (right).

At the command march, the threes wheel in full circle to the left on a fixed pivot. The leading guide faces to the left and marks time until the marching flank of the leading three passes him, when he again faces to the left, advances to within facing distance of the pivot, again faces to the left, marking time so as to conform to each quarter circle described by

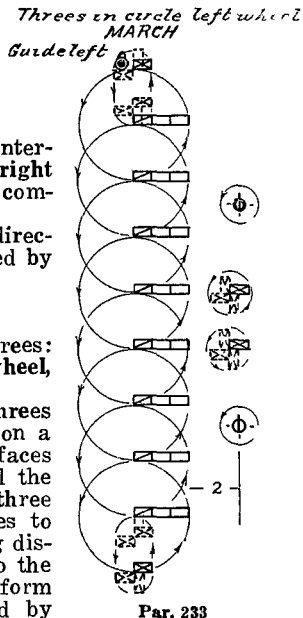

the wheeling threes; as the threes enter the last quarter of the circle, the guide again faces to the left and moves to the front, the Commander giving the third command. The guide in rear conforms in the same manner to the movements of the rear three. File closers conform to the movements of the threes, turning in their places. In column of threes, the circle wheel and the about are executed towards the side opposite the file closers.

A column of sections is wheeled about, and in full circle, the same as a column of threes, in which case it is executed towards the side opposite the file closers.

MOVEMENTS BY SECTIONS

See Par. 179, 197, 198, 200, 203, 204, 205, 207, 233. In all cases section chiefs giving necessary commands.

Forward MARCH *Form sections Left oblique MARCH*

To Form Column of Sections from Column of Threes

234. Being in march: 1. Form sections left (right) oblique, 2. MARCH, 3. Forward, 4. MARCH.

At the command march, the odd numbered threes take the half step; the even numbered threes oblique to the left until they uncover the threes next in front of them, when they resume the forward march; the fourth command is given the instant the threes unite in sections, the sections preserve the distance of one hundred and twenty inches between ranks and the guides fifty-four inches from the leading and rear files, respectively. The Standard Guard, if present, obliquates to a central position between the sections.

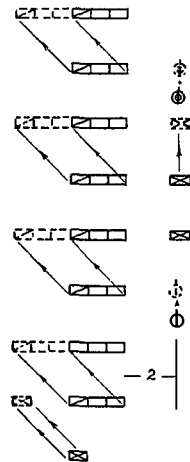

To Break into Column of Threes from Column of Sections

235. 1. Form threes right oblique, 2. MARCH.

At the command march, the right threes continue the march in the full step, the left threes oblique to the right, resuming the forward as soon as the left file regains the trace of the leading guide, who takes post in front of number three of the right three at the command march. See note, Par. 215.

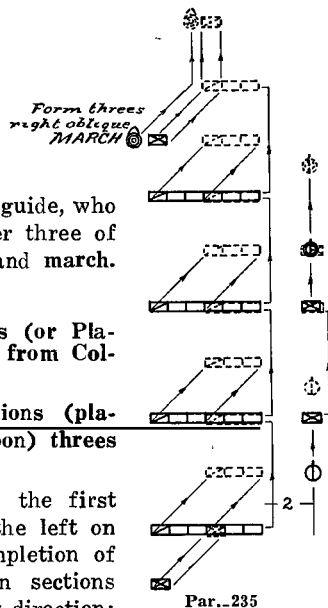

To Form Column of Sections (or Platoons) to the Left or Right, from Column of Threes

236. 1. Column of sections (platoons), 2. First section (platoon) threes left (right), 3. MARCH.

At the command march, the first and second threes wheel to the left on moving pivots; upon the completion of the wheel the threes unite in sections and move forward in the new direction; at the same time the leading guide places himself fifty-four inches in front of the left file of the section. The remaining threes move forward, each section executing the same movement successively upon the same ground, the chiefs of sections giving the necessary commands. The left guide follows the left file of the rear section.

A column of platoons is formed to the left or right, from a column of sections upon the same principles; the chief of the first platoon giving the commands: 1. Sections left (right) into line wheel, 2. MARCH, the remaining chiefs cautioning, forward; and

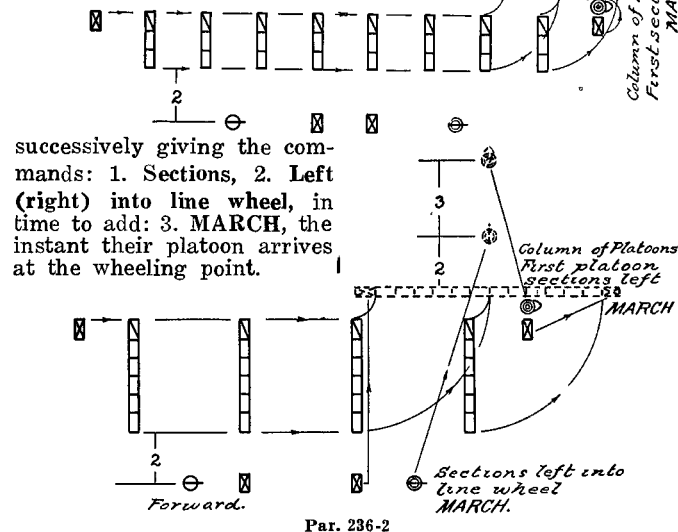

To Form Column of Threes to the Right or Left, from Column of Sections or Platoons

237. 1. Column of threes, 2. First section (platoon) threes right (left), 3. MARCH.

At the second command, the leading guide, if not already

there, places himself in front of the file on the flank toward which the movement is to be executed; at the command **march**, the threes of the leading section wheel to the right on a moving pivot, and follow the trace of the guide.

The sections in rear of the first move forward, and each in succession executes the same movement upon the same ground, its chief giving the proper commands.

The guide in rear follows the file on the marching flank of the rear three.

A column of sections is formed to the right or left from column of platoons, upon the same principles, by the command: 1. **Column of sections**, 2. **First platoon sections left wheel**, 3. **MARCH**.

Omit To Close Column to Half-Distance

238. Being in march: 1. **To half-distance, close column**, 2. **MARCH**.

At the command **march**, the leading subdivision halts; the others continue the march, and as each in succession arrives at one-half distance from the one which precedes it, is halted.

The file closes close to one pace at the command **march**.

If at a halt, the chief of the first subdivision cautions it to stand fast, the other chiefs caution, forward, and the movement is completed as explained.

If marching in **quick time**, and the command be **double time**, the chief of the first, cautions, **quick time**; the other chiefs repeat the command **double time**, and **march**, and each commands: 1. **Quick time**, in time to add: 2. **MARCH**, upon closing to half distance.

If marching in **double time**, the movement is executed in a similar manner; the chief of the first cautions, **quick time**, and repeats the command **march**.

To Take Full Distance

239. Being in march: 1. **Take full distance**, 2. **MARCH**.

At the command **march**, the subdivisions in rear of the first mark time, and successively resume the march the in-

stant wheeling distance is gained, the chiefs giving the proper commands.

If marching in **double time**, the leading subdivision continues the cadence; at the first command of the Commander the chiefs of the other subdivisions command: **Quick time**, repeat the command **march**, and successively command: 1. **Double time**, in time to add: 2. **MARCH**, when at wheeling distance.

To Form Line to the Front Faced to the Rear

241. Being in column of threes: 1. **Right (left) front into line faced to the rear**, 2. **MARCH**, 3. **Commandery**, 4. **HALT**, 5. **FRONT**.

The first command is executed as explained in Par. 207, except that at the command **halt**, the leading three wheels left about on a fixed pivot, halts and dresses to the right; the other threes march a few inches beyond the alignment, successively wheel to the left about and dress to the right.

In forming front into line faced to the rear, the threes wheel about toward the **point of rest**.

Front into line faced to the rear is executed from column of sections upon the same principles.

To Advance in Line of Sections in Column of Threes

242. Being in line: 1. **Sections, right (left) by threes**, 2. **MARCH**, 3. **Guide right (left)**.

At the command **march**, each section executes the movement, Par. 198. The guides place themselves in front of the left files of the right threes of the several sections respectively. The Commander marches three paces in front of the line of guides and opposite the center, or central interval.

The chiefs caution their respective sections. The Standard Guard marches in line with the leading threes. The chiefs of platoons follow in rear of their platoons.

243. Being in line of sections in column of threes, to reform line: 1. **Sections, left (right) front into line**, 2. **MARCH**, 3. **Commandery**, 4. **HALT**, 5. **Right (left)**, 6. **DRESS**, 7. **FRONT**.

At the command **march**, each section executes **left front into line**.

If executed in double time, the Commander commands: **Guide right**, immediately after the command **march**, without halting.

244. Having advanced by the flank of sections, to form sections to the left or right: 1. **Threes left (right)**, 2. **MARCH**, 3. **Guide right (left)**.

At the command **march**, the threes of each section wheel to the left on fixed pivots.

To March by the Flank of Sections

245. Being in column of sections: 1. **Threes right (left)**, 2. **MARCH**, 3. **Guide left (right)**.

At the command **march**, the threes wheel to the right. The guides place themselves in front of the files on the marching flanks of the leading threes of the several sections. Chiefs of platoons march in the rear of their respective platoons.

Before marching a column of sections by the flank, the Commander announces the guide on the flank towards which the movement is to be made.

To March by the Flank of Sections from Column of Threes

246. Being in march: 1. **Sections, column right (left)**, 2. **MARCH**, 3. **Guide left (right)**.

Each chief of section repeats the second command; and at the command **march**, the leading three of each section changes direction to the right, followed by its rear three.

The guides, if not already there, place themselves in front of the files on the marching flanks of their respective sections. Chiefs of platoons pass between the subdivisions to the rear of their platoons.

247. To march again in column of threes: 1. **Sections, column left (right)**, 2. **MARCH**.

As soon as the leading threes have changed direction, the guide in rear takes his post in rear of the left file of the rear three.

Order in Echelon

248. Being in line at a halt, to advance in echelon: 1. **Threes, from the right (left or center)**, front into echelon, 2. **MARCH**, 3. **Guide right (left or center)**.

At the command **march**, the right guide marches straight to the front; the right three takes up the march at the proper distance from the guide; the Knight next to the guide carefully preserves the distance and direction, always holding his three opposite its place in line. Each three in succession, takes up the march when the three next toward the guide has advanced wheeling distance to the front. Each file closer follows the three in his front. Files or sections into echelon is executed in a similar manner. The advance into echelon may be made from the center, or from both flanks at once.

Being in column of platoons or commanderies, to advance by the flanks in echelon: 1. **Threes, etc., from the right (left)**, 2. **Front into echelon**, 3. **MARCH**, 4. **Guide right (left)**.

Each subdivision executes the movement as explained.

The commandery in echelon, may be marched by the flank, by the commands: 1. **Threes, etc., right**, 2. **MARCH**, 3. **Guide left (right)**.

To the rear by the commands: 1. **Threes, etc., right (left)** about, 2. **MARCH**, 3. **Guide right (left)**.

249. Being in echelon by threes, to form sections, the Commander commands: 1. **Form sections**, 2. **MARCH**, 3. **Forward**, 4. **MARCH**.

At the command **march**, the leading three of each section marks time; the third command being given when the threes unite in sections, when all will resume the full step.

Threes from sections are formed in an inverse manner, the commands being: 1. **Form threes in echelon**, 2. **March**.

Platoons from sections, and the reverse, are formed upon the same principles, the chiefs taking post in front of their subdivisions.

The Standard Guard, if present, maintains its central position.

To Reform Line

250. 1. Front into line, 2. MARCH, 3. Right (left or center), 4. DRESS, 5. FRONT.

At the command march, the leading subdivision halts; the others successively halt and dress upon arriving in line. (Par. 328).

To Form in Echelon from Column of Twos or Files

251. 1. Files right and left into echelon, or, 1. Files right (left) into echelon, 2. MARCH, 3. Guide center.

At the command march, the leading guide continues the march in the half step; the right files oblique to the right in echelon, each in succession resuming the forward march when his left shoulder covers the right shoulder of the file in his front. The left files oblique to the left in echelon upon the same principles. The guide in rear follows in echelon the file in his front, and the chief of the second platoon follows in echelon the opposite flank. The Standard Guard, if present, marks time until the rear of the column approaches, when it marches to the front abreast of the chief of the second platoon, the Standard Bearer following the trace of the leading guide. The chief of the first platoon takes post on a line midway between the leading guide and the Standard Bearer, and in the absence of the Standard Guard, marches in its place. The Commander gives the third command the instant the movement is completed. The third and fourth guides are on the right and left of the chief of the first platoon.

To Reform Column

1. Form twos (files), 2. MARCH.

At the first command the chiefs return to their posts in column, and the Standard Guard marches in double time to the center. At the command march, the files oblique toward the center, uniting in column of twos or files and move to the front.

MOVEMENTS BY PLATOONS

252. Whenever the flanks of a commandery become its

center, the right and left guides move into the line of file closers taking the posts prescribed respectively for fourth and third guides, each with his own platoon; the third and fourth guides take the posts prescribed respectively for the left and right guides.

To Form Column of Platoons to the Right or Left

253. Being in line, at a halt: 1. Platoons right (left) wheel, 2. MARCH.

At the first command, the chiefs of platoons take post

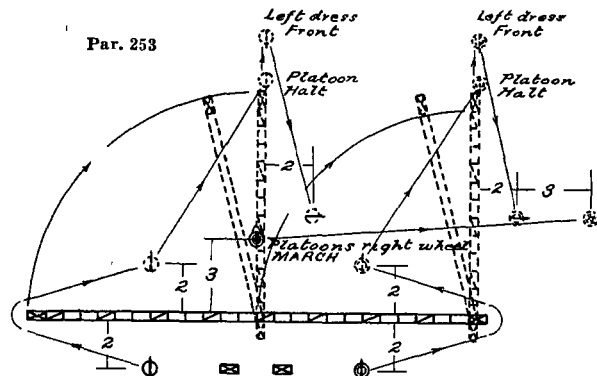

two paces in front of the centers of their platoons, passing in double time around the flanks. At the command march, the platoons wheel to the right on fixed pivots, Par. 81, the right guide stands fast, the left guides conduct the marching flanks; each chief hastens to the point where the left of his platoon will rest on the completion of the wheel, faces the late rear, and, when the marching flank approaches the perpendicular, commands: 1. Platoon, 2. HALT, 3. Left (right), 4. DRESS, 5. FRONT. At the command halt each left guide

places his left arm against the breast of his chief, who then steps back two paces, dresses his platoon, and takes post two paces in front of its center. The right guides take post on the right of the pivot Knights at the command front.

If in march, the commandery wheels into column of platoons by the same commands as at a halt. At the command **march**, the guides halt and the pivots mark time; the chief of the rear platoon takes his post by passing between the platoons; the platoons are halted and dressed as before. Whenever the commandery is formed in column of platoons, or line of platoons in columns of threes, the file closers who act as guides of platoons, place themselves as such as soon as practicable, unless otherwise specifically stated.

The Standard Guard, if present, moves straight to the front, nearly one-half platoon distance, wheels to the right on a moving pivot, advances to a point midway between the platoons, and halts.

The position of the Commander is three paces in front of the chief of the leading platoon.

Whenever in column a subdivision is dressed, its chief, (if a file closer), after commanding **front**, places himself in front of its center. This rule is general.

254. Being in line, to wheel into column of platoons and move forward without halting:

1. Continue the march, 2. Platoons right (left) wheel, 3. **MARCH**, 4. Forward, 5. **MARCH**.

The platoons wheel as before, except that each chief remains in front of the center of his platoon; at the command forward, the right guides of platoons place themselves on the right of the pivot Knights; the guide of the leading platoon prolongs his direction by choosing successive points in advance; the guides of the second and succeeding platoons carefully preserve the trace, step, and distance.

NOTE—In column of platoons, companies or commanderies the guide is always right unless otherwise designated. This rule is general.

To Put the Column of Platoons in March

255. 1. Forward, 2. **MARCH**, 3. Guide right (left).

256. To halt the column: 1. Commandery, 2. **HALT**.

To Oblique the column of Platoons, and to Resume the Direct March

257. 1. Right (left) oblique, 2. **MARCH**.

To resume the direct march: 1. Forward, 2. **MARCH**.

To Change Direction in Column of Platoons

258. Being in march: 1. Column right (left), 2. **MARCH**.

At the first command, the chief of the first platoon commands: **Right wheel**. At the command **march**, repeated by the chief, the platoon wheels to the right on a moving pivot, the chief adding: 1. Forward, 2. **MARCH**, upon the completion of the wheel.

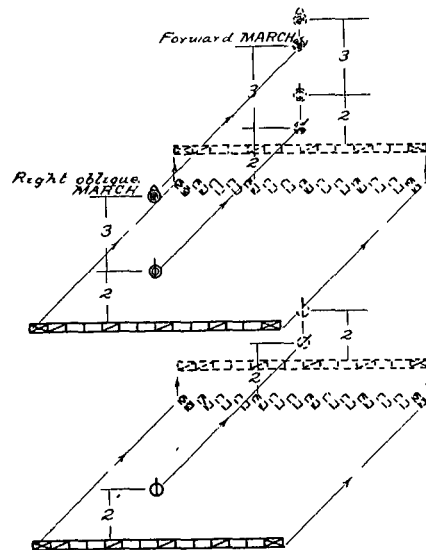

Par. 257

The second platoon marches squarely up to the wheeling point, and then changes direction by the same commands and means as did the first.

If more than two platoons the others will conform to the

movements described for the second platoon. This rule is general.

Par. 258

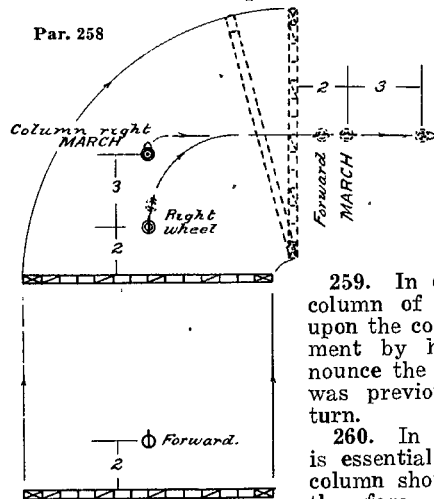

Column half right, or half left, is similarly executed; each chief gives the preparatory command: Right (left) half wheel.

259. In changing direction in column of platoons, each chief, upon the completion of the movement by his platoon, will announce the guide on the flank it was previous to the wheel, or turn.

260. In changing direction, it is essential that the rear of the column should never be checked; therefore, each chief faces his

subdivision during the wheel, and sees that the guide takes the full step of thirty or thirty-six inches, and that the moving pivot describes the circle of 30 inches.

261. To put the column of platoons in march and change direction at the same time: 1. Column right (left), or, 1. Column half right (half left), 2. MARCH.

At the command march, the first platoon wheels to the right on a moving pivot.

To Face the Column of Platoons to the Rear, and to March It to the Rear

262. 1. Threes right (left) about, 2. MARCH, 3. Commandery, 4. HALT; or, 3. Guide right (left).

At the command march, the threes wheel about on fixed

pivots, the platoon leaders dart through the nearest intervals, and place themselves two paces in front of the centers of their platoons; at the command halt, given the instant the threes complete the about, the platoons halt; each chief dresses his platoon to the left.

To march to the rear without halting, the Commander announces the guide the instant the about is completed.

If the column be faced to the rear, and one platoon be smaller than the other, the guide of the second platoon regains the trace and wheeling distance on the march.

To Form Line to the Left or Right from Column of Platoons

263. Being at a halt: 1. Platoons left (right) into line wheel, 2. MARCH, 3. Commandery, 4. HALT, 5. Right (left), 6. DRESS, 7. FRONT.

At the command march, the left guides stand fast; the platoons wheel to the left on fixed pivots.

At the command halt, the chiefs return to the line of file closers, passing around the marching flanks of their platoons and the right guide of the rear platoon takes his post in the line of file closers. The Commander places himself on line with the left guides, assures the position of the right guide, and steps back two paces, facing the line. At the command dress, the platoons dress up to the line; the breasts of the pivot Knights against the arms of the guides. At the command,

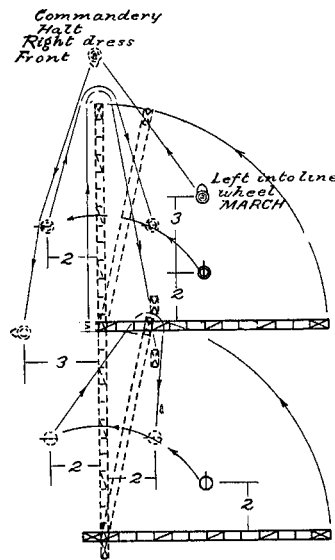

Par. 263

front, the interior left guide (guides) return quickly to the line of file closers, passing around the flank by the shortest route.

Before forming line from column of platoons, the guide, if not already there, is announced on the flank toward which the line is to be formed; the guides of the second and succeeding platoons carefully cover the guide of the first at the proper distance.

If marching, the movement is executed as just explained; except that, at the command **march**, the guides halt; the pivots mark time, and turn in their places, so as to conform to the movements of the marching flank.

264. To form line and continue the march: 1. Continue the march, 2. Left (right) into line wheel, 3. **MARCH**, 4. **Forward**, 5. **MARCH**.

At the command **forward**, the chiefs of platoons and guides return to their posts in line. The pivots mark time, turning carefully in their places until the completion of the wheel.

When platoons are about to unite in line, or column of threes, Par. 272; guides at the center take their posts in the line of file closers. This rule is general.

To Form Line on the Right or Left from Column of Platoons

265. Being in march, the Commander announces the guide, if not already there, on the flank toward which the movement is to be executed, and commands:

1. **On right (left) into line**, 2. **MARCH**, 3. **Commandery**, 4. **HALT**, 5. **FRONT**.

At the first command, the chief of the first platoon commands: **Right turn**. At the command **march**, repeated by its chief, the first platoon executes the right turn. Par. 196. The command **halt** is given when the leading platoon has advanced commandery distance in the new direction. Its chief commands: 1. **Right**, 2. **DRESS**, and returns to his post, passing around the right flank.

The chief of the second platoon, at the first command, cautions **Forward**, commanding: 1. **Right turn**, in time to add: 2. **MARCH**, when opposite the left of the first platoon; when the right file has arrived on the line he commands: 1. **Platoon**, 2. **HALT**, 3. **Right**, 4. **DRESS**, and takes his post, passing around the left flank.

The Commander superintends the alignment from the right flank and commands: **FRONT**.

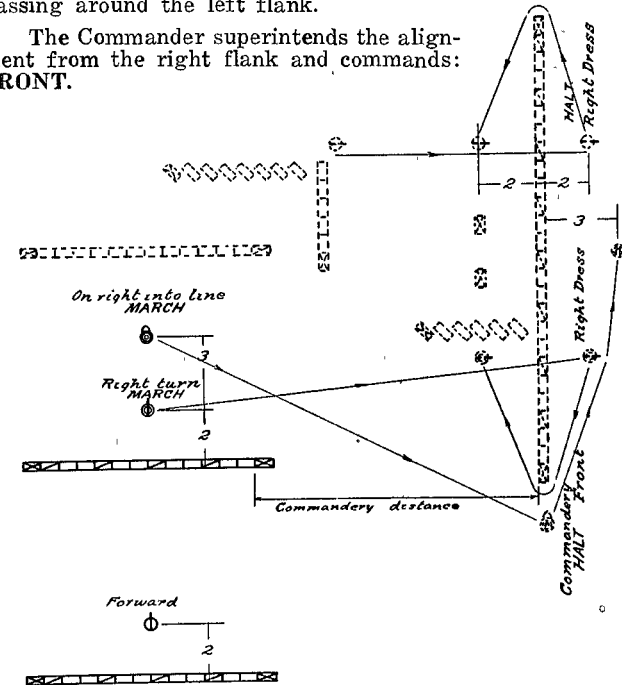

To Form Column of Platoons to the Front

266. Being in line at a halt: 1. Right by platoons, 2. MARCH.

At the first command the chiefs pass in double time to their places in front of their platoons; the chief of the right (first) platoon commands: 1. Forward, 2. Guide left. The chief of the left (second) platoon commands Threes right. At the first command March, the first platoon moves straight to the front three paces, then shortening ten or twelve steps, again takes the full step, its chief commanding, 1. Short step, 2. MARCH, and Forward March; the second platoon executes threes right, its chief commanding: 1. Threes left, 2. MARCH, 3. Guide left, in time to follow in trace of the first platoon.

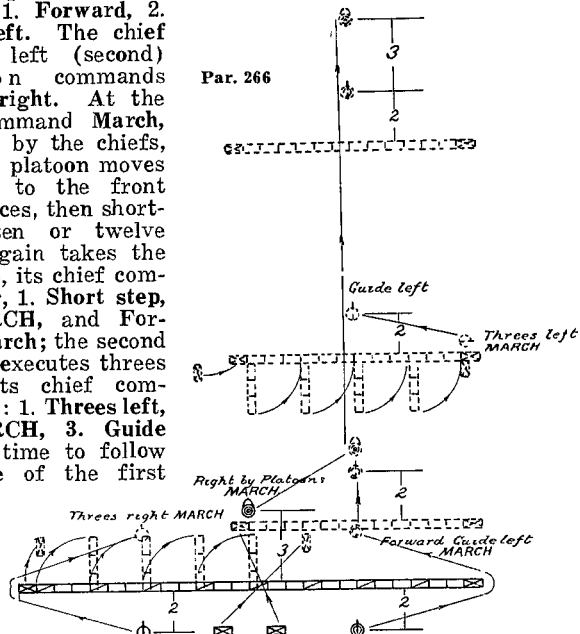

Interior guides take their posts as the platoons form in column.

If marching the chief of the first platoon omits the command forward.

Succeeding platoons follow the movements of the second platoon.

The movement may be executed toward the opposite flank by similar commands and means.

To Reform the Commandery

267. Being at a halt: 1. Left (right), front into line, 2. MARCH, 3. Commandery, 4. HALT, 5. FRONT.

At the first command the chief of the first platoon commands: 1. Forward, 2. Guide right. The chief of the second platoon commands: Left oblique.

At the command march, repeated by the chiefs, the first platoon advances, commandery distance, when its chief commands: 1. Platoon, 2. HALT, 3. Right, 4. DRESS, and takes his post, passing around the right flank. The second platoon obliqued to the left, its chief commanding: 1. Forward, in time to add, 2. MARCH, 3. Guide right, the instant the platoon is opposite its place in line; on arriving near the line its chief commands: 1. Platoon, 2. HALT, 3. Right, 4. DRESS, and takes his post, passing around the left flank.

The Commander superintends the alignment from the right flank, and gives the third command upon its completion.

If marching, the chief of the first platoon commands: Guide right, and the movement is completed as just explained.

If marching in quick time, and the command be double time: Guide right (left) is given immediately after the command march.

The chief of the leading platoon cautions it to advance in quick time, and repeats the command for the guide; the chief of the second platoon commands: Left oblique, repeats the command, double time, and, when the platoon is about to arrive in line, commands: 1. Quick time, in time to add, 2. MARCH, the instant it is abreast of the leading platoon; the platoons having united, the chiefs return to their posts, passing around the flanks.

If marching in double time, the chief of the first platoon, at the first command, commands: Quick time, and repeats the command march, also that for the guide.

If three or more platoons, those succeeding, conform to the movements of the second platoon.

To March the Column of Platoons by the Flank

268. 1. Threes right (left), 2. MARCH, 3. Guide left (right).

The threes in each platoon wheel to the right, the guides place themselves in front and rear of the file on the marching flank of the leading and rear threes, the chiefs of platoons on the left of the leading guides; the heads of subdivisions preserve an alignment toward the flank on which the guide is announced, and preserve the distance from that flank, necessary to form line to the front. The Commander takes post three paces in front of the line of leading guides and opposite the center of the interval between the platoons.

269. To march again in column: 1. Threes left (right), 2. MARCH, 3. Guide right (left).

At the second command, each chief places himself in front of the center of his platoon.

To March Platoons in Column of Threes to the Front

270. Being in line: 1. Platoons right (left) by threes, 2. MARCH, 3. Guide left (right).

At the first command, the chiefs pass in double time to their places in front of the platoons; at the command march, each platoon executes right

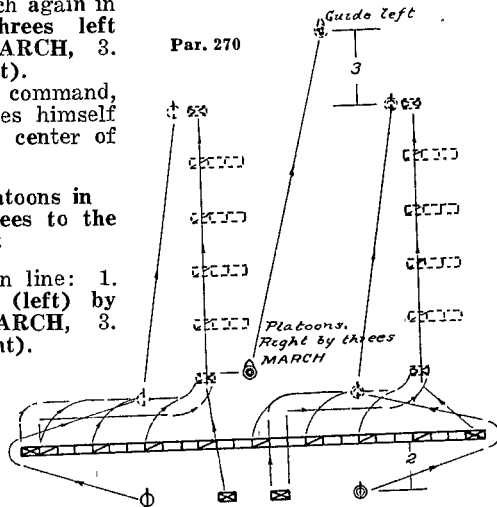

by threes, the right guide of each platoon passing in double time to his place in front of the left file of the leading three of his platoon (Par. 198). The chiefs are on the left of the guides, and the Commander three paces in front of the line of leading guides and opposite the center of the interval between the platoons.

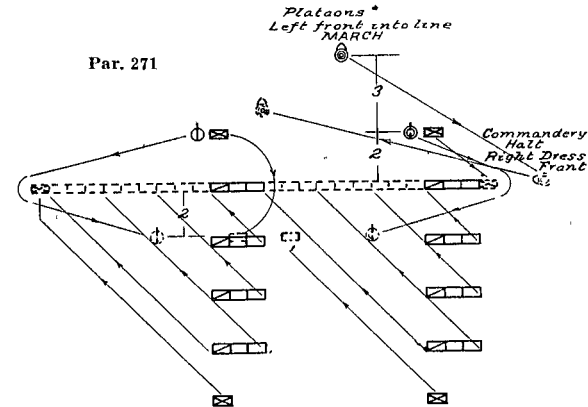

271. To form in line again: 1. Platoons left (right) front into line, 2. MARCH, 3. Commandery, 4. HALT, 5. Right (left), 6. DRESS, 7. FRONT.

At the command march, each platoon executes front into line, the chiefs return to their places in line by passing around the right or left of the platoons. The command halt is given when the leading threes have advanced commandery distance.

If the movements be executed in double time, the Com-

mander commands: **Guide right (left)** after the command **march**.

To Form Column of Threes from Column of Platoons

272. 1. **Platoons right (left)** by threes, 2. **MARCH**.

The chiefs pass around the heads of their platoons as they are about to unite in column of threes; the right guide of the first platoon places himself in front of the leading three at the command **march**; the right guide of the second platoon and the left guide of the first platoon take their places in the line of file closers as the platoons are about to unite in column.

To Form Column of Platoons from Column of Threes

273. 1. **Platoons left (right) front into line**, 2. **MARCH**, 3. **Commandery**, 4. **HALT**.

At the first command, each chief, if not already there, darts through the column and places himself on its left, near the head of his platoon. At the command **march**, each platoon executes left front into line.

The chiefs place themselves in front of the centers of their platoons and the guides take their posts.

At the command **halt**, given when the leading three of each platoon has advanced commandery distance, each chief verifies the alignment and commands **front**.

If executed in double time, or in quick time, and the command be **double time**, the Commander commands: **Guide right (left)**, immediately after the command **march**.

274. Being in line of platoons or sections, in column of threes at a halt, to form column of threes to the right or left: 1. **Platoons, etc., column right (left)**, 2. **MARCH**. The chiefs of platoons take their posts, passing around the heads of their platoons as they are about to unite in column of threes.

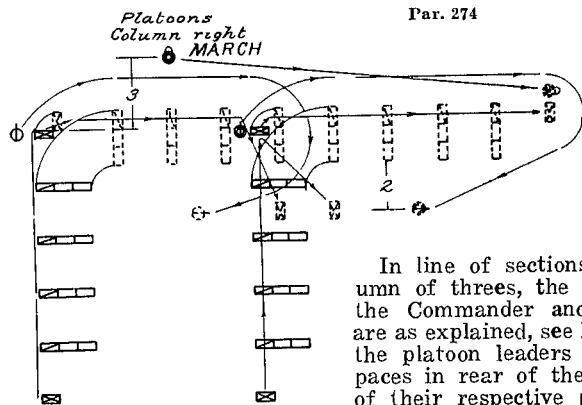

275. Being in column of threes, a line of platoons (sections) in column of threes to the right (left) is formed by the commands: 1. **Platoons (sections) column right (left)**, 2. **MARCH**, 3. **Guide right (left)**.

Executed on principles previously explained the guides taking post at the command **march**.

For position of sections, see Par. 189.

To Play the Commandery into Column of Platoons

omit or Companies

276. Being in line at a halt: 1. **Column of platoons, on first platoon**, 2. **Right (left) in front**, 3. **Threes right (left)**, 4. **MARCH**.

At the first command, the chiefs hasten to place themselves in front of their platoons; the chief of the first in front of its center; the others in front of the right files, facing to the right.

At the third command, the chief of the first platoon commands: 1. **First platoon forward**, 2. **Guide left**; the other chiefs repeat the fourth command,

At the command **march**, repeated by all the chiefs, the first platoon moves forward, its chief commanding: 1. **First platoon**, in time to add: 2. **HALT**, when it has advanced platoon distance and three paces, he then dresses it to the left and takes his post. The other platoons wheel by threes to the right; the chief of the second conducts his platoon parallel to the line, halts in the trace of the left file of the first, and when his platoon has nearly passed him, commands: 1. **Second platoon, Threes left**, 2. **MARCH**, 3. **Platoon**, 4. **HALT**.

The command **march** is given the instant the left file is in rear of the left file of the first platoon, when the threes wheel to the left; the chief posts the left file platoon distance in rear of the left file of the first, and then dresses his platoon to the left. Each of the other platoons after wheeling by threes to the right, inclines to the rear conducted by its chief, and then to the left so as to enter the column in rear of, and on a line parallel to the preceding platoon. The chiefs conform to what is prescribed for the chief of the second. If in march, the chief of the first platoon omits the command for putting it in march, and cautions, **guide left**; the movement is completed as before.

277. Whenever the ployment is in front of the designated subdivision, the guides face to the rear, and the movement is completed by the commands: 1. **Guides, About**, 2. **FACE**. This rule is general.

The column is played on the fourth (left) platoon, left or right in front, by similar commands and means; the subdivisions being dressed to the right.

If the Commandery is in march, and the ployment be in front of the designated subdivisions, its chief halts it at the command **march**.

The Close Column

278. The commandery is played into column at half distance, by substituting for the first command: 1. **Close column on first platoon**.

To Form Column of Threes from Close Column

279. Being at a halt: 1. **Column of threes**, 2. **First platoon, Right by threes**, 3. **MARCH**.

The chief of the first platoon repeats the commands, and at the command **march**, the platoon executes the movement. The other chiefs successively designate their platoons, and give the same commands in time to follow in column of threes the one preceding.

A close column marches by the flank, resumes the march in column, faces to the rear, changes direction, is put in march, and halted, by the same commands as at full distance.

To Deploy the Column of Platoons or Companies

280. Being at a halt: 1. **On first platoon deploy column**, 2. **Threes left (right)**, 3. **MARCH**, 4. **FRONT**.

At the second command, the chief of the first platoon cautions it to stand fast and hastens to place himself a little in front of its right flank; the right and left files (guides) step promptly a little to the front and align themselves on their chief; the other chiefs repeat, **threes left**, and place themselves three paces in front of the left files, facing to the left.

At the command **march**, the chief of the first platoon dresses his platoon to the right, and takes his post in line, the platoon dressing up to its right and left files; the rear platoons execute threes left and move forward, the chief of the second platoon stands fast, and as the rear three approaches him, commands: 1. **Second platoon**, 2. **Threes right**, 3. **MARCH**, 4. **Guide right**.

The third command is given the instant the rear three arrives opposite the left file of the first platoon, when it executes threes right; its chief, taking post in front of its center, halts it one pace from the line, commands: 1. **Right**, 2. **DRESS**, and takes his post. The other platoons march abreast of and parallel to the second. The chiefs of the remaining subdivisions conform to the movements of the subdivision next preceding it, as explained. The last subdivision being aligned, the Commander gives the fourth command.

If marching, the chief of the first platoon halts it at the command **march**; the movement being completed as explained.

To Deploy Column on the Rear Subdivision, (with Four Platoons More or Less)

281. 1. On fourth (or rear) platoon deploy column, 2. Threes left (right), 3. MARCH, 4. FRONT.

At the command **march**, all the platoons except the fourth (or rear), wheel by threes to the left, the chiefs repeating the second and third commands; the chief of the third halts opposite the left of the fourth, and when the rear of his platoon approaches him, commands: 1. **Third platoon**, 2. **Threes right**, 3. **MARCH**, 4. **Guide right**; the third command being given the instant the fourth platoon is unmasked.

The chief of the fourth platoon commands: 1. **Fourth platoon**, 2. **Forward**, 3. **Guide right**, repeats the command **march**, conducts his platoon to the front, halts it eight paces beyond the ground occupied by the first platoon, and takes post a little in front of its right flank; the right and left files step promptly a little to the front and align themselves on their chief, who commands: 1. **Fourth platoon**, 2. **Right**, 3. **DRESS**, and takes his post.

The chief of the third platoon conducts it to the front, halts it one pace from the line, and commands: 1. **Third platoon**, 2. **Right**, 3. **DRESS**, and takes his post. The remaining chiefs conform to what is explained for the chief of the third. The first platoon being aligned, the Commander gives the fourth command.

The interior guides take their posts in the line of file closers when the platoon is halted.

The commandery being in march, the chief of the fourth (or rear) subdivision cautions, forward, and the movement is completed as just explained.

282. To deploy the column on an interior subdivision:
1. On (such) platoon deploy column, 2. Threes right and left, 3. MARCH, 4. FRONT.

At the command **march**, the subdivisions in front of the one designated deploys to the right, those in rear deploy to the left. The designated subdivision moves to the front with the guide left, is halted three paces beyond the ground occupied by the first subdivision, and dressed to the left; the

other subdivisions are dressed toward the designated subdivision.

If marching, the designated subdivision continues the march, and the movement is completed as before.

To Close Subdivisions in Mass

283. Being in column at a halt: 1. Close in mass, 2. MARCH.

At the command **march**, the leading subdivision stands fast, the others move forward, successively halting at one pace distance. If in march, the leading subdivision halts at the command **march**. Platoon and company leaders take post on the flank, by the side of their leading guide.

To take full distance: 1. Take full distance, 2. MARCH. The leading subdivision moves forward, the others mark time and successively move forward when distance is gained.

284. Being in line at a halt, to close the column of threes in mass to the right: 1. Close in mass, 2. Threes right, 3. MARCH.

At the command **march**, the threes wheel to the right, the leading three halts, and the others complete the movement as just explained.

To Form Double Column of Files in Open Order from Column of Sections

285. Being in column of sections at half distance: 1. Threes right and left by file, 2. MARCH, 3. Guide left.

At the command **march**, the right threes of sections execute right by file, and the left threes, left by file. The guides precede and follow the column at facing distance. The third guide takes post at the second command.

To reform sections, the Commander commands: 1. Sections front into line, 2. MARCH, 3. Forward, 4. MARCH.

At the command **march**, the leading files in each section take the half step, the other files oblique left and right, forming threes toward the center of the double column, and reuniting in sections.

NOTE—A convenient method of forming the lines at "open order" for the purpose of rendering honors. Par. 158.

To Wheel Subdivisions in Circle Consecutively

286. Being in line, to augment the subdivisions by wheeling them in circle consecutively: 1. **Threes in circle right (left) wheel**, 2. **MARCH**, 3. **Sections, in circle right (left) wheel**, 4. **MARCH**, 5. **Platoons in circle right (left) wheel**, 6. **MARCH**, 7. **Commandery, in circle right (left) wheel**, 8. **MARCH**, 9. **Commandery**, 10. **HALT**, 11. **Left (right)**, 12. **DRESS**, 13. **FRONT**, or, 9. **Forward**, 10. **MARCH**, 11. **Guide left (right)**.

At the command march, the threes wheel in circle to the right on fixed pivots. The third command is given in time to add, march, the instant the threes reunite in line, when the sections wheel in circle to the right or left. In like manner, sections are augmented to platoons, and platoons to commandery, which also wheels in circle on a fixed pivot. The guides do not describe a circle, but march in prolongation of the line a distance sufficient to permit the subdivision in the rear to wheel clear of them. The guides face with each quarter of the circle, and

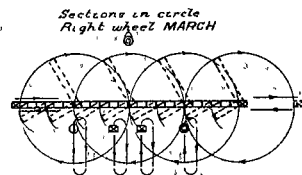
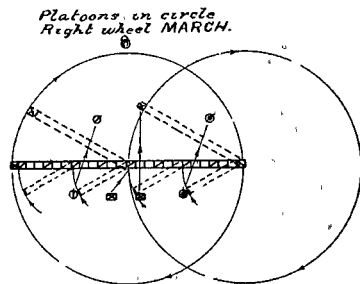

Par. 286

in the same direction with the subdivisions. When the marching flank passes the guide, he faces toward the center and marches on the pivot, facing to the front as the subdivisions unite in line. The guides alternately march away from, or toward the center, the file closers alternately toward and from the line; according as the subdivisions wheel toward, or away from them. The file closers mark time during the wheel by threes, and with the guides take post at the fifth command as in column of platoons, Par. 81-253. At the seventh command they take post as in line, Par. 193.

When platoons or larger subdivisions wheel in circle, the guide will be the pivot. A variation of this movement is effected, by alternating the commands so that the threes wheel to the right, the sections to the left, the platoons to the right, etc.

The Standard Guard, if present, wheels in circle with the threes upon a fixed pivot; in the wheels by sections, it wheels upon a moving pivot, describing a circle large enough to enable it to occupy its central position in column, and to unite with the sections in line. In the wheel by platoons, etc., it conforms to the same principles as in wheeling by sections. The commandery having wheeled in circle, the subdivisions may be reduced by wheeling them in a circle consecutively by inverse commands and means.

COMMANDERY DISPLAY MOVEMENTS

287. The following movements are intended for public parade and display; they are arranged to conform to the general rules and principles previously laid down.

In display drill, for the purpose of forming emblematic figures, the Commander is often required to exercise his ingenuity to its utmost. It is impossible always to have the same number of Knights in line; and a slight variation in the number present necessitates a change in the formation to produce the required results.

To form the passion cross with twenty-four Knights if it is desired to change from the unit of three to a unit of four, the Commander causes fours to be counted, preferably at the formation of the commandery.

It is also necessary to have the commandery divided into four equal parts in order to form the Greek cross and Square.

To March from the Center in Column of Sixes to the Front

288. Being in line: 1. Center forward, 2. Threes left and right, 3. MARCH, 4. Guide right (left).

At the second command, the chiefs pass in double time around the flanks and place themselves two paces in front of their platoons, facing the center, and opposite the second threes from the center of the command-

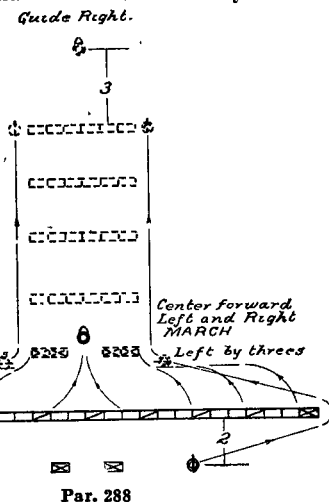

Par. 288

Omit!

ery. The chief of the first platoon commands: 1. Left by threes; the chief of the second platoon: 1. Right by threes. At the command march, repeated by the chiefs, a double column of threes is formed, advancing to the front in sixes at half distance.

The chiefs of platoons march abreast of their leading threes. The guides follow in rear of the rear subdivision at fifty-four inches distance. The Commander takes post three paces in front of the center of the leading subdivision.

NOTE—If the Standard Guard be present, it leads the movement, marching straight to the front, the leading threes inclining to the right and left to close the interval. Extra file closers, if any, march in rear of the last section abreast of the guides.

To Form Line to the Front

289. 1. Right and left front into line, 2. MARCH, 3. Commandery, 4. HALT, 5. On center, 6. DRESS, 7. FRONT.

At the first command, the chief of the first platoon commands: Right front into line; the chief of the second platoon: Left front into line; at the command march, repeated by the chiefs, the platoons execute the movement. Par. 207. At the command halt, given when the leading subdivision has advanced platoon distance, the leading section (or Standard Guard) halts; the chiefs take post by dropping to the rear, passing between the threes; the movement is completed on principles previously explained. Line is formed in this manner only when the original center of the commandery is in front.

To Form Line to and on the Right or Left

289a. Being in column of sixes at half distance: 1. Threes right (left), 2. Left (right) threes on right (left) into line, 3. MARCH, 4. FRONT.

At the second command, the chief of the first platoon commands: 1. First platoon, 2. Threes right; the chief of the second platoon continues forward and commands: 1. On right into line, 2. MARCH. At the command march, repeated by

Omit
 the chief of the first platoon, the right three wheel to the right uniting in line; its chief commands: **Guide right**, takes post two paces in front of its center, and conducts it platoon distance in the new direction and commands: 1. **First platoon**, 2. **HALT**, 3. **Right**, 4. **DRESS**, and returns to his post, passing around the right flank.

The second platoon executes on right into line, its chief giving the preparatory command in time to add: **MARCH**, as the leading three arrives opposite its place in line, when it wheels out of the column and marches onto the new alignment; its chief commands: 1. **Second platoon**, 2. **HALT**, 3. **Right**, 4. **DRESS**, and returns to his post, passing around the left flank.

To Form Front into Line Faced to the Rear from Column of Platoons or Companies

290. 1. **Right (left) front into line faced to the rear**, 2. **MARCH**, 3. **FRONT**.

At the first command, the chief of the first subdivision commands: 1. **Forward**, 2. **Guide left**, the other chiefs command: **Right oblique**. At the command **march**, repeated by the chiefs, the first subdivision advances subdivision distance, when it is halted by its chief who commands: 1. **Threes left about**, 2. **MARCH**, 3. **Platoon**, 4. **HALT**, 5. **Right (left)**, 6. **DRESS**, and returns to his post in line, passing around the right flank. Each of the other chiefs successively commands: **Forward**, in time to add: **March**, the instant his subdivision uncovers the one in front, conducts it to the front, halts it three paces beyond the line, wheels it to the left about by threes, halts it, dresses it to the right, and returns to his post in line. The last subdivision being aligned, the Commander commands: **FRONT**.

To Form Line on the Standard from Column of Threes

291. Being in march, and the Standard present: 1. **On Standard into line**, 2. **MARCH**, 3. **Forward**, 4. **MARCH**.

At the first command, the chief of the first platoon commands: **Threes right about**; the chief of the second: **On**

Standard, left front into line. At the command **march** repeated by the chiefs, the Standard Guard takes one step and marks time; the first platoon executes threes right about, its chief commanding: 1. **On Standard, left front into line faced to the rear**, in time to add: 2. **MARCH**, the instant the about is completed, when the threes of the first platoon oblique sharply to the left, so that on passing the line, the leading three will have gained an interval to the left of the Standard Guard equal to its front; each three successively wheels about to the right, aligning on the Standard Guard, and marks time. The second platoon executes left front into line on the Standard Guard and marks time. At the fourth command, the line marches to the front.

If at a halt, each chief, upon forming line, will dress his platoon towards the Standard Guard; the Commander verifies the alignment, and commands: 3. **FRONT**.

To Wheel on the Center

292. Marching in line: 1. **On center, in circle left (right) wheel**, 2. **MARCH**, 3. **Commandery**, 4. **HALT**, 5. **On center (right or left)**, 6. **DRESS**, 7. **FRONT**.

At the first command, the chief of the first platoon passes in double time in front of the center of his platoon, and commands: **Left wheel**; the chief of the second platoon commands: 1. **Second platoon**, 2. **To the rear**, 3. **Left wheel**. At the command **march**, given as the right foot strikes the ground, the first platoon wheels to the left; the second platoon executes to the rear, and immediately wheels to the left. Each chief faces his platoon during the wheels. Interior guides conform to movement of their platoons.

Upon executing **halt**, the chief of the first platoon passes around the right flank to his post in line; the chief of the second platoon commands: 1. **Second platoon**, 2. **About**, 3. **FACE**; the Commander giving the remaining commands. Should the Commander desire the commandery to advance in line without halting, he commands: 3. **Forward**, 4. **Guide center**; the chief of the second platoon commanding: 1. **Second platoon**, 2. **To the rear**; the Commander gives the com-

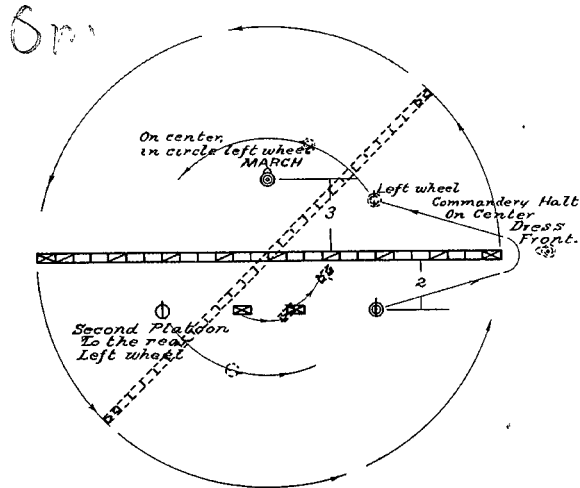

Par. 292

mand: 4. **MARCH**, as the right foot strikes the ground, when the second platoon executes to the rear, and all move to the front. The chief of the first platoon takes his post at the command forward, and the chief of the second, at the command march. The Standard Bearer marks time in his place, turning his body so as to conform to the movements of the right wing. The Warder wheels with the left wing.

Should the Standard Guard be absent, the pivot Knights of each wing gain ground slightly, retaining the touch of the elbow on each other.

To March in Double Column of Threes to the Rear, Left in Front, from Column of Sections Right in Front

293. 1. Threes right and left about, 2. **MARCH**, 3. Guide center.

At the command march, the right threes execute right about, and the left threes left about, on fixed pivots.

The leading guide turns to the right, and places himself in the center of the interval between and abreast of the rear threes; at the same time the guide in rear obliquates to the right until past the line of pivots, executes to the rear, and places himself, on the completion of the about, in the center of the interval between, and abreast of the leading threes.

The file closers place themselves in the interval opposite their respective posts, and follow the trace of the leading guide.

The Standard Guard, if present, wheels left about, and obliquates to a central position in the column. The Commander follows in trace of the guide in rear.

To Reform Sections, Right in Front

294. 1. Form sections, 2. Threes right and left about, 3. **MARCH**, 4. Guide left.

At the command march, the left column of threes executes right about, and the right column left about; the threes uniting in sections, move to the front as the guide is announced. The guides and chiefs of platoons return to their posts in column at the third command.

To March in Double Column of Threes to the Rear, Right in Front, from Column of Sections Right in Front

295. 1. Threes, countermarch column right and left, 2. **MARCH**, 3. Guide left.

At the first command, the leading guide places himself in front of the right file; at the command march, the right threes countermarch to the right in column, and the left threes to the left in column, on moving pivots. The leading guide places himself in front of the left file of the leading three of the left column; the guide in rear places himself in front of the left file of the leading three of the right column as it approaches. The chiefs take post in rear of the right files of the first and fourth sections at the command march,

countermarching with them and as soon as the left of the column has passed them, take post in the interval opposite them respectively.

The third and fourth guides, in like manner, take post with the second and third sections.

To Reform Sections Right in Front

296. 1. Form sections, 2. Countermarch column right and left, 3. MARCH, 4. Guide left.

At the command **march**, the columns countermarch right and left, the threes uniting in sections and advancing through the double column. The guides wheel in front of the marching flanks of their respective threes, and as soon as the rear of the double column approaches, the left guide takes post in rear of its right three; at the same time the right guide takes post in front of the left file of the leading section. The chiefs and file closers oblique to the left and follow the nearest three until the leading section of their platoon approaches them, when they in turn follow it until the rear of the double column is passed, when they return to their posts in columns of sections.

Movements explained for sections can be executed by platoons, substituting in the command platoons for sections, unless otherwise provided.

Being in Column of Sections, to Wheel Threes in Circle Right and Left

297. 1. Threes in circle, right and left wheel, 2. MARCH, 3. Guide left (right).

At the command **march**, the right threes wheel in circle to the right, and the left threes to the left on fixed pivots; the guides conforming to the movements of the threes as explained in Par. 233.

The Commander gives the third command as the threes unite in sections, when all move to the front.

The Standard Guard if present marks time in its place until the command for the guide.

To Wheel the Threes in Circle Alternately

298. 1. Right threes in circle right wheel, 2. MARCH.

At the command **march**, the right threes wheel in circle to the right, the left threes continuing the march to the front; the circle being nearly completed, the Commander commands: 1. Left threes in circle left wheel, and adds: **MARCH**, the instant the circle is complete, at which the right threes move to the front, and the left threes wheel in circle to the left; when the left threes complete the circle the sections will be united, and all will move to the front, when the Commander announces the guide.

The Standard Guard if present obliques to the left at the first command, and conforms to the movements of the left threes, and upon the guide being announced, obliques to its position in column of sections.

To Break by the Right of Platoons to the Rear into Column

299. Being in line at a halt: 1. Right (left) of platoons rear into column, 2. Threes right (left), 3. MARCH.

At the first command, each chief hastens to place himself two paces in front of the right file of his platoon, facing to the right; and at the second command, cautions the right three to wheel to the right about.

At the command **march**, all the threes wheel to the right; the leading three in each subdivision wheels to the right about, the last half of which is on a moving pivot, and marches straight to the rear; each chief places himself on the marching flank of the leading three as it approaches him, wheels to the rear with it, and halts on the line lately occupied by it, so that the marching flank of each three shall graze his right arm in passing to the rear. When the rear three nearly completes the wheel to the rear, the chief commands: 1. Threes left (right), 2. MARCH, 3. Platoon, 4. HALT, 5. Left (right), 6. DRESS, 7. FRONT.

The command **march** is given the instant the rear three has passed the chief; and the fourth command as the threes unite in line; the left file places his left arm against the breast of his chief, who steps back two paces and gives the

Ornit

fifth, sixth and seventh commands, and takes his post. The Standard Guard, if present, wheels about, and marches to a central position, wheels to the left and halts.

To continue the march to the rear: 1. **Right of platoons to the rear**, 2. **Threes right (left)**, 3. **MARCH**, 4. **Guide left (right)**.

Executed the same, except the chiefs conduct the leading threes straight to the rear.

To march again in column: 1. **Threes left (right)**, 2. **MARCH**, 3. **Guide left (right)**.

To Break from the Right to March to the Left

300. Being in line: 1. **Threes**, 2. **Break from the right (left) to march to the left (right)**, 3. **MARCH**.

At the command march, the right three moves three paces straight to the front, then changes direction to the left marching parallel to the front of the commandery. The right

guide places himself in front of the left file and conforms to the movement of the first three. The second three moves to the front when the first three arrives opposite its right file, changes direction to the left and follows the first three. Each of the other threes successively conform to the movement of the three next preceding it. The same movement is applicable to other subdivisions, substituting sections, twos, files, etc., for the command threes.

301. A similar movement is executed by platoons: 1. **Column of threes**, 2. **Platoons, break from the right (left) to march to the left (right)**, 3. **MARCH**.

At the second command, the

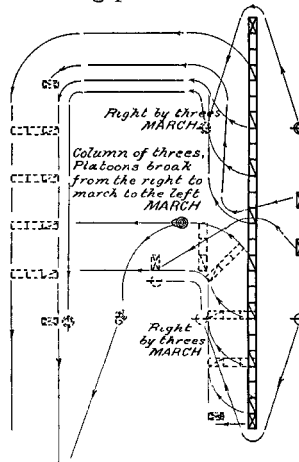

Par. 301

Ornit

chiefs hasten to place themselves in front of the centers of their platoons. At the third command, the chief of the first platoon commands: 1. **Right by threes**.

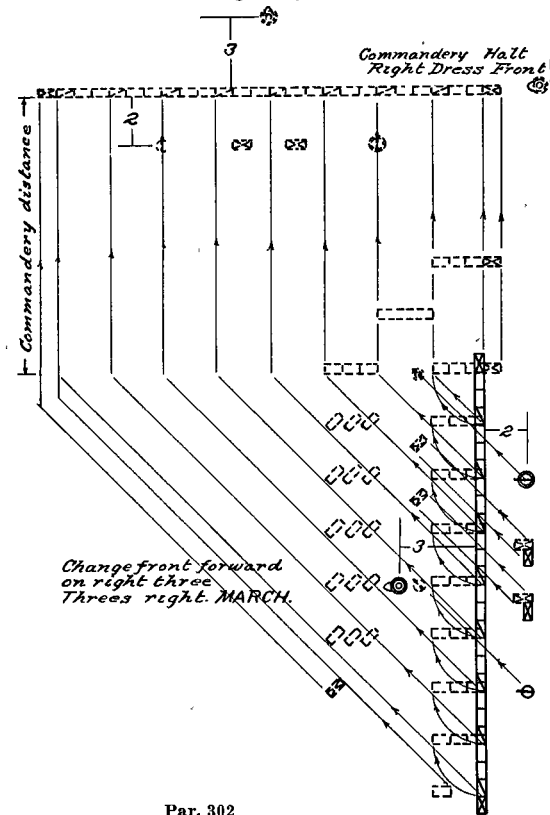

Par. 302

At the command march, repeated by the chief of the first platoon, it moves in column of threes to the front; its chief commanding: 1. Column left, in time to add: 2. MARCH, the instant the leading three has advanced platoon distance; the guide then directs his march parallel to the front of the commandery. The chief of the second platoon commands: 1. Right by threes, in time to add: 2. MARCH, the instant the leading three of the first platoon arrives opposite his right three; the leading three marches platoon distance to the front, changes direction as explained for the first platoon and follows in its rear. The other platoons successively conform to what is explained for the second.

To Change Front

302. Being in line, to change front to the right or left: 1. Change front forward on right (left) three, 2. Threes right (left), 3. MARCH, 4. Commandery, 5. HALT, 6. Right (left), 7. DRESS, 8. FRONT.

At the command march, the threes wheel to the right, the right guide places himself on the right of the first three and conducts it to the front; the other threes, upon wheeling to the right, execute left front into line upon the first three. The command halt is given when the leading three has advanced commandery distance, though the leading three may be halted at a less distance when necessary.

To Form a Line to the Rear Facing to the Right

303. Being in line at a halt: 1. From right to rear into line, 2. MARCH, 3. FRONT.

The commandery executes threes right about; the first (right) three marches straight to the rear commandery distance, executes threes left and halts dressing to the right, forming the basis for the new alignment; the other threes likewise march to the rear, the second three wheeling to the left and advancing so as to form line on the left of the first

Cont.

three; the third and each succeeding three marches to the rear, wheels to the left and advances so as to form line on the left of the preceding three, all halting in rear of the line and dressing to the right without command. The second three will march to the rear a distance fifty-four inches less than the first three, and the last (left) three will execute threes right about and wheel to the left advancing to the new alignment.

To Form Line to the Rear Facing to the Left

304. Being in line at a halt: 1. Threes right about, 2. By threes on left into line faced to the rear, 3. MARCH, 4. FRONT..

The commandery executes threes right about, advances two paces to the rear, and executes By threes on left into line faced to the rear; the first (right) three after moving to the rear two paces, executes threes left on a moving pivot, advances two paces in the new direction, wheels to the left about, halts and dresses to the right without command, thus fixing the basis for the new alignment; the remaining threes march to the rear until opposite their places in the line, plus fifty-four inches, then change direction to the left, pass beyond the line, wheel to the left about, halt and dress to the right without command.

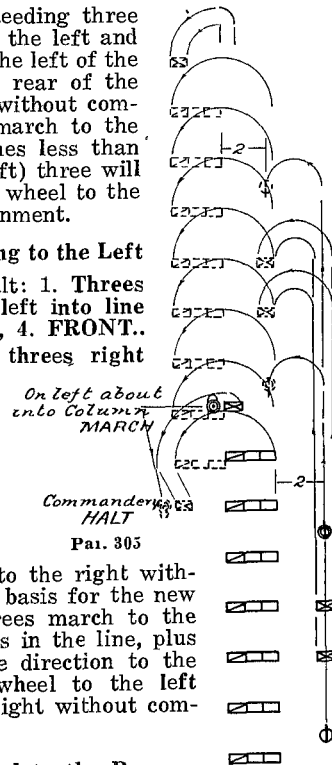

To Form the Column Faced to the Rear

305. The Commander desiring to counter march the column without retracing the ground passed over, commands: 1. On left about into column, 2. MARCH, 3. Commandery, 4. HALT.

At the command **march**, the leading subdivision countermarches to the left; at the fourth command, given when the about is completed, it halts. The other subdivisions march a distance equal to their fronts beyond the wheeling point of the subdivision next preceding, countermarch to the left and halt at wheeling distance from the one in front.

The Command-er commands *Left in front in circle left wheel* or *right about*, according as the right or left is in front.

To Invert the Column of Threes or Sections

306. Being in march right in front: 1. **Left in front**, 2. **In circle left wheel**, 3. **MARCH**, 4. **Guide right**.

At the command march, the rear three marks time, the left guide taking post in front of the right file; the other threes wheel three-quarters of the circle to the left on moving pivots and mark time in line. The rear three resumes the forward march the instant the threes in front commence to mark time; when it arrives opposite the left file of the three next in front, that three wheels to the left and follows it; the other threes successively wheel to the left and follow the three next on its right as previously explained.

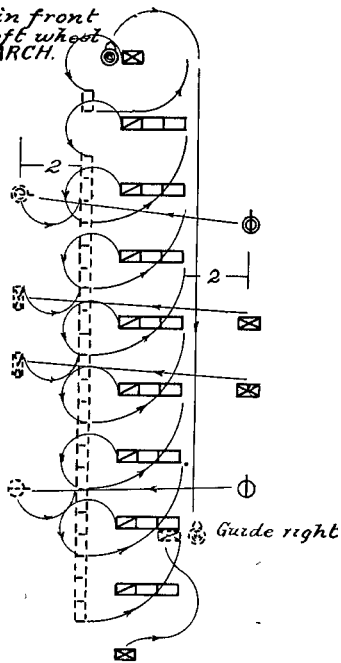

Par. 306

The file closers dart through the column at the command march.

If the left be in front: 1. **Right in front**, 2. **In circle right wheel**, 3. **MARCH**, 4. **Guide left**.

A column of threes may be inverted by the commands: 1. **Left (right) in front**, 2. **In circle left and right (right and left) wheel**, 3. **MARCH**, 4. **Guide right (left)**.

At the command march, the odd threes wheel to the left, and the even threes to the right, on moving pivots, each marking time on completing three-quarters of the circle. The movement is completed on principles previously explained.

307. A column of sections, either at full distance or half distance, is inverted by the commands: 1. **Left (right) in front**, 2. **Threes in circle left and right (right and left) wheel**, 3. **MARCH**, 4. **Guide right (left)**.

At the command march, the rear section marks time; the right threes wheel to the right, and the left threes to the left, on moving pivots, each marking time on wheeling three-quarters of the circle. The rear section resumes the forward march as the threes commence to mark time; the threes of the section next in front wheel right and left into section, which follows the rear section at proper distance. The other sections successively wheel threes right and left, and follow the section next towards the rear. The chief of each section gives the necessary commands. The file closers dart through the column at the command march. The Standard Guard, if present, wheels toward the side of the guide.

The Greek Cross

308. The Greek cross is a perpendicular cross, the arms of which are equal.

The commandery being in march in column of four equal subdivisions, to form Greek cross: 1. **Form Greek cross**, 2. **MARCH**, 3. **Forward**, 4. **MARCH**, 5. **Guide center**.

At the command march, the first subdivision executes right by file, the second subdivision executes right oblique; the third subdivision continues the march, obliquing slightly to the left; the fourth subdivision executes right by file. The

chiefs caution their respective subdivisions, the chief of the second commanding: 1. **Forward**, in time to add: 2. **MARCH**, the instant his subdivision uncovers the one in front. The leading guide takes post in front of the leading file, and conducts the subdivision straight to the front in the half step; the guide in rear follows the rear file. The third guide takes post in rear of the first, and the fourth guide in front of the fourth subdivision, respectively. The chief of the first platoon takes post on the right of the second subdivision, and the chief of the second platoon, on the left of the third; the chief of the second darting through the column at the command march. The Commander takes his post in the center, at the fourth command, when all resume the full step.

If the Standard Guard be present, it obliquates to the right until the Standard Bearer is in the trace of the first subdivision, when it resumes the forward march, taking position in the center of the cross; the second and third subdivisions oblique to the

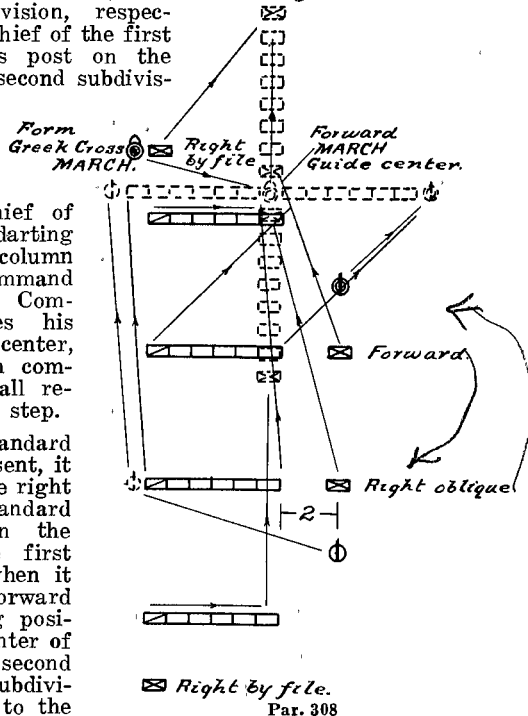

right and left respectively a distance sufficient to admit the Standard Guard between them. The Commander takes post in front of the leading guide.

To Form Column of Four Subdivisions From Greek Cross

309. Being in march: 1. Form column, 2. **MARCH**, 3. **Forward**, 4. **MARCH**, 5. **Guide left**.

At the first command, the chiefs caution their respective subdivisions as follows: The first and fourth, **Left front into line**. The second, **Left oblique**. The third, **Mark time**.

At the command **Forward**, the different subdivisions execute their respective commands; numbers one of the first and fourth taking one step and then marking time; the second subdivision obliquates to the left until it covers the first, and then marks time until it regains its wheeling distance when it resumes the forward march; the other subdivisions successively resume the forward march upon regaining their distance from the one preceding.

The Commander gives the fourth command the instant the last file of the first subdivision arrives in line, when the first subdivision resumes the forward march.

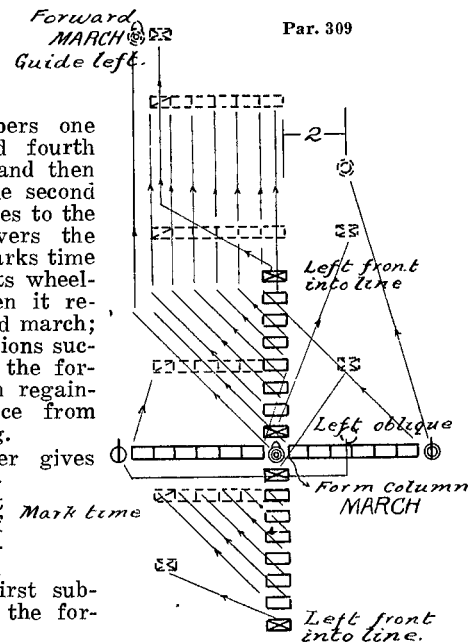

Marching in Column of Four Subdivisions to Display Greek Cross

310. 1. Display Greek cross, 2. In circle left (right) wheel, 3. MARCH, 4. Forward, 5. MARCH.

At the second command, the guides, if not already there, place themselves on the flanks farthest from the center of the cross. The Commander places himself on the pivot flank of the leading subdivision.

At the command march, the first subdivision wheels in circle to the left on a moving pivot around the Commander. The other subdivisions move forward, each in succession wheeling to the left on the same ground as the first; the guides conduct the marching flanks of the several subdivisions, and carefully preserve the alignment with each other. The chiefs mark time in their places until the column resumes the march. The first subdivision having wheeled in complete circle, moves again to the front, at the half step, conducted by the right guide, who places himself in front of the left file. At the fifth command all move forward at the full step.

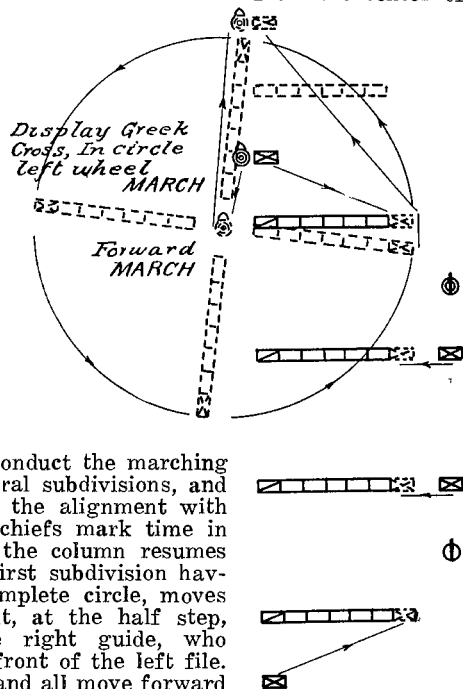

Par. 310

If the Standard Guard be present, it obliques to the left and forms a close group in the center facing inward; the Color being supported in the center.

311. To wheel Greek cross in circle, and change direction at the same time.

The movement as explained in Par. 310, may be executed changing direction of the column at the same time, the Commander prefixing the commands by **Column right (left)**.

At the command **march**, the leading subdivision wheels the full circle, and then changes direction as indicated in the command; the other subdivisions successively execute the same movement upon the same ground.

The Passion Cross

312. The Passion or Latin cross has the lower arm longer than the others, and is variously formed, according to the number of Knights in line. A column of five, six, or seven subdivisions makes the best proportioned cross. With fifteen, eighteen, twenty-one or twenty-four Knights, the cross is preferably formed from a column of threes; with thirty, thirty six, or forty-two, from a column of sections; with forty-eight, from a column of sections (eights) in a unit of four formation.

Being in march in column of threes, fours or sections, with six subdivisions, to form Passion cross: 1. Form Passion Cross, 2. MARCH, 3. Forward, 4. MARCH, 5. Guide Center.

At the command march, the first three executes right by file, and advances in the half step; the second three obliques to the right and forms the right arm; the third three continues the march, obliquing slightly to the left; the fourth, fifth, and sixth threes execute right by file. If the Standard Guard be present it obliques to the right, the Standard Bearer following in trace of the leading three; the second and third threes obliquing right and left respectively, sufficient to admit the Standard Guard between them.

The chiefs and guides take post as in Par. 308.

The Commander takes his post at the fourth command when all resume the full step.

Threes in excess of the number used in forming the cross may close in mass and constitute a base to the cross.

Om To Form Column from Passion Cross

313. Being in march: 1. Form threes (fours or sections), 2. MARCH, 3. Forward, 4. MARCH, 5. Guide left.

At the command march, the first, fourth, fifth and sixth threes execute threes left front into line, the second three obliques to the left; the third three and Standard Guard, if present, mark time. At the fourth command, given the instant the last file of the first three arrives in line, the leading three resumes the full step; the others resume the forward march at wheeling distance from the three next preceding; the third three obliquing to the right until in trace of the three next in front. The Standard Guard obliques to the left and follows the third three.

To Form Passion Cross from Column of Threes with Twenty-Four Knights

314. 1. Form Passion Cross, 2. MARCH, 3. Forward, 4. MARCH, 5. Guide Center.

At the first command march the first three executes right by file and advances in the half step, conducted by the right

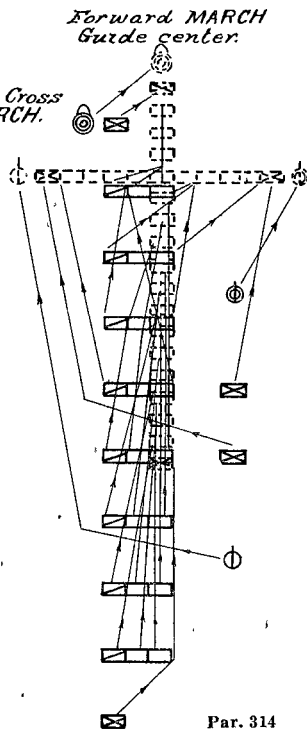

Par. 314

guide; the third three takes one oblique step to the right and marches forward, its number two closing on the rear file of the upper arm; the second three obliques to the right and the fourth three to the left, and with the third three forms the right and left arms of the cross; the remaining threes execute right by file, closing on the center to form the lower arm of the cross.

The Commander takes post in front of the leading guide, the third guide and chief of the first platoon at the extremity of the right arm, the fourth guide and chief of the second platoon at the extremity of the left arm, the second guide follows the lower arm.

The Commander takes his post at the fourth command when all resume the full step.

To Reform Column of Threes

315. 1. Form threes, 2. MARCH, 3. Forward, 4. MARCH.

At the first command March the first and rear threes execute threes left front into line, Par. 216, the second, third and fourth threes oblique into column, the platoon leaders and guides resume their posts, at the fourth command all move forward at the full step.

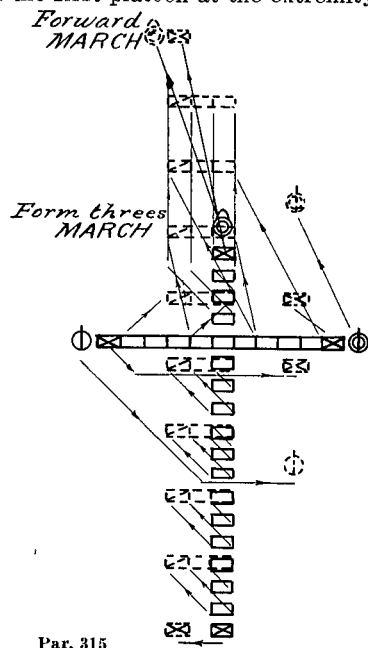

Par. 315

The Patriarchal Cross

316. The Patriarchal cross is composed of a single upright, and two cross arms; and is equivalent to two Greek crosses joined together; the Standard Guard, if present, being placed at the points of intersection.

Its simple formation is from a column of eight subdivisions.

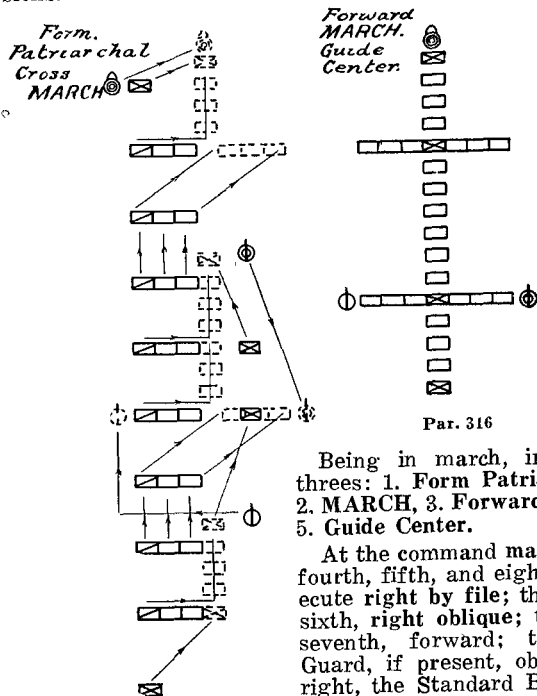

Being in march, in column of threes: 1. Form Patriarchal Cross, 2. MARCH, 3. Forward, 4. MARCH, 5. Guide Center.

At the command march, the first, fourth, fifth, and eighth threes execute right by file; the second and sixth, right oblique; the third and seventh, forward; the Standard Guard, if present, obliquates to the right, the Standard Bearer follow-

ing the trace of the last file of the fourth three. The leading guide takes post in front of the leading file, and moves to the front at the half step; the guide in rear follows the last file of the eighth three.

The chief of the first platoon takes post on the right of the second cross, and the chief of the second platoon, on the left of the second cross. The Commander gives the fourth command when the subdivisions are united, and takes post in front of the leading guide.

The third guide fills the center of the first cross, and the fourth guide the second cross.

317. Patriarchal cross from column of eight sections is formed upon the same principles, the chiefs of sections giving the necessary commands.

318. To form again in column: 1. Form threes, 2. MARCH, 3. Forward, 4. MARCH, 5. Guide left.

At the command march, the first, fourth, fifth, and eighth threes execute left front into line; the second and sixth, left oblique; the third and seventh, mark time.

At the fourth command, given when the last file of the leading three arrives in line, the leading three resumes the full step; the others successively resume the forward march at wheeling distance from the three next preceding; the third and seventh threes oblique to the right, and the Standard Guard, if present, to the left.

The Cross of Salem

319. The cross of Salem is composed of one upright and three cross arms, the Standard Guard, if present,

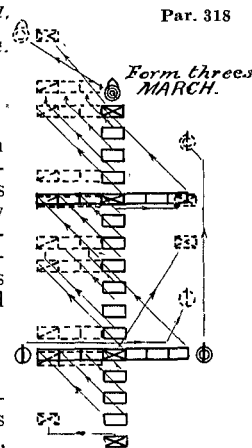

being in the center cross arm. It is formed from a column of twelve subdivisions.

Being in march, in column of threes, to form cross of Salem: 1. Form cross of Salem, 2. MARCH, 3. Forward, 4. MARCH, 5. Guide center.

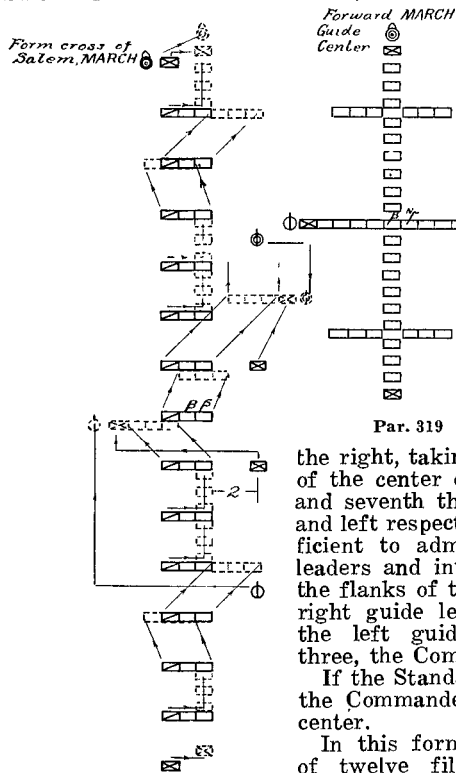

Par. 319

At the command march, the first, fourth, fifth, eighth, ninth, and twelfth threes execute right by file; the second, sixth and tenth, right oblique; the third, seventh, and eleventh, forward. The Standard Guard, if present, obliqués to

the right, taking post in the center of the center cross arm, the sixth and seventh threes obliquing right and left respectively a distance sufficient to admit it. The platoon leaders and interior guides are on the flanks of the center arm. The right guide leads the first three, the left guide follows the last three, the Commander at the head. If the Standard Guard be absent, the Commander takes post in the center.

In this formation, each platoon of twelve files forms a Greek cross; the three crosses uniting forms a cross of Salem.

The cross can be formed with twenty-four knights in column of twos. Par. 217.

320. To form again in column: 1. Form threes, 2. MARCH, 3. Forward, 4. MARCH, 5. Guide left.

At the command march, the column is formed upon principles explained in Par. 318.

The Cross of St. Andrew

321. The cross of St. Andrew is a diagonal cross, the arms of which are equal.

Being in march in column of platoons: 1. Form Cross of St. Andrew, 2. MARCH, 3. Forward, 4. MARCH, 5. Guide center.

At the first command, the chief of the first platoon commands:

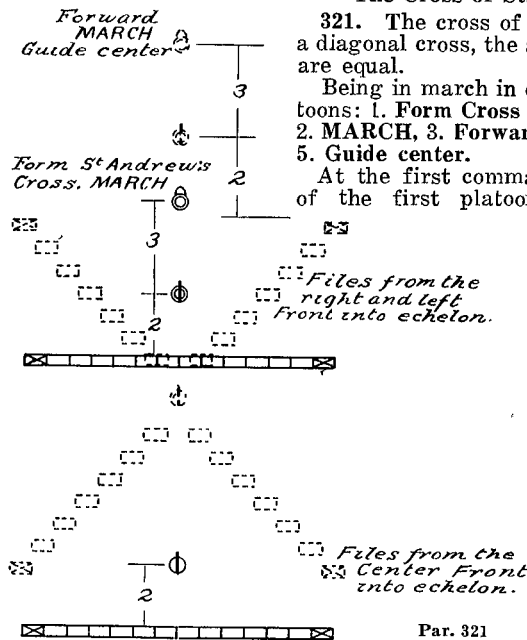

Par. 321

1. Files from right and left, 2. Front into echelon; the chief of the second: 1. Files from the center, 2. Front into echelon.

At the command **march**, the right and left files, the guides of the first platoon, march straight to the front, shortening the step, and preserving with the greatest care the interval between them; the Knights mark time, and successively resume the march from each flank at facing distance in echelon; the center files gain an interval between them of twenty-two inches. The center files of the second platoon advance to the front and exactly cover the center files of the first platoon at thirty-two inches distance, the other files mark time and successively resume the march at facing distance in echelon. The guides of the second platoon follow their respective flanks of the cross at facing distance. The Standard Guard, if present, marches straight to the front, closing upon the first platoon; the Sword Bearer steps in front of the Standard Bearer between the center files of the first platoon; the Warder falls to the rear and covers the Standard Bearer, taking post between the leading files of the second platoon. The Commander marches three paces in front of the chief and guides of the first platoon. If the Standard Guard be absent the chief of the second platoon marches in the center of the cross.

To Reform Platoons

322. 1. Form platoons, 2. MARCH.

At the first command, the chiefs of platoons command: **Front into line**. At the command **march**, the leading guides mark time, the Knights successively marking time upon arriving in line. As soon as the center files of the first platoon and the flank files of the second platoon arrive in line, their chiefs command: 1. **Forward**, 2. **MARCH**, 3. **Guide left (right)**.

The Standard Guard, if present, reforms and resumes the march at proper distance from the first platoon.

The Egyptian Cross

323. The Egyptian or Tau cross is the same as the Passion cross with the upper arm wanting (T). It is formed from column of four or five subdivisions.

Being in march in column: 1. **Form Egyptian cross**, 2. **MARCH**, 3. **Forward**, 4. **MARCH**, 5. **Guide center**.

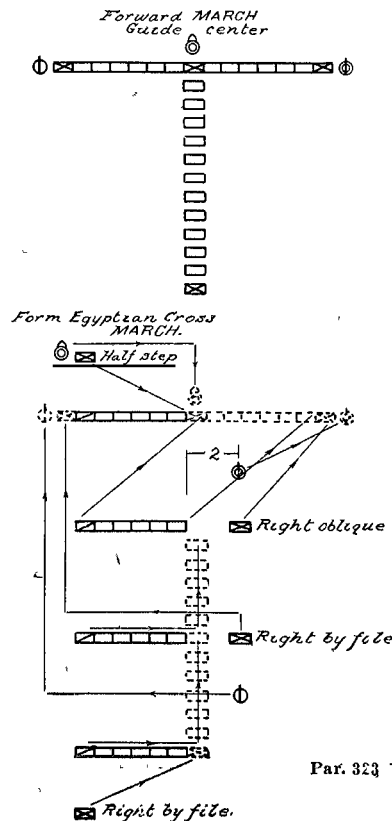

At the first command, the chiefs of sections caution respectively, first section, **half step**; second, **right oblique**; third and fourth, **right by file**; at the same time the leading guide places himself on the right of the leading section. At the command **march**, the first section advances in the half step guiding to the right; the second section obliquely to the right, its chief commanding: 1. **Forward**, in time to add: 2. **MARCH**, the instant it uncovers the first section; when it advances to the front guiding to the left; the third and fourth sections execute right by file and move to the front. The chief of the first platoon places himself on the right of the second section, and the chief of the second platoon, on the left of the first. The third and fourth guides take post on the flanks of the cross arm, each preceding his chief. The Commander gives the fourth command, and places himself

three paces in front of the leading guide. If the Standard Guard be present it closes on the center, the Standard Bearer covering the leading guide at facing distance.

324. To form again in column: 1. **Form column**, 2. **MARCH**, 3. **Guide left**.

At the first command, the first section continues the march in the full step, the guide placing himself in front of the left file; the second section obliquates to the left; the third and fourth execute left front into line. The sections resume the full step when at wheeling distance from the one next in front.

To Form Square

325. Being in march in four subdivisions: 1. **Form square**, 2. **MARCH**, 3. **Forward**, 4. **MARCH**, 5. **Guide left (right)**.

At the first command, the chiefs of subdivisions command as follows: The first, **Half step**. The second and third: **Right and left by file**, covering the guides. The fourth: **Forward**. At the command march, the chiefs take post in rear of the first, and in front of the fourth subdivisions respectively; at the same time the guides place themselves on the flanks of the first and fourth subdivisions. The first subdivision continues to march in the half step; the second and third execute **right and left by file**, and the fourth continues the march in the full step. The Commander takes position in the center of the square.

If the Standard Guard be

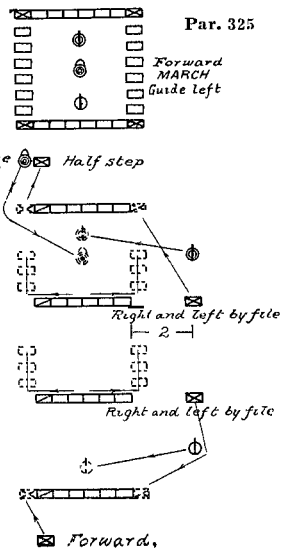

present it takes the center, the Commander taking post in front of the Standard Bearer.

The leading files of the second subdivision cover the right and left guides of the first platoon. The right guide of the second platoon and the left guide cover the rear files of the third subdivision. The Commander seeing the square well closed up gives the fourth command, when all resume the full step.

The commandery in the form of a square may be marched by the flank, or caused to execute to the rear.

To Reform Column

326. 1. **Form column**, 2. **MARCH**, 3. **Guide left (right)**.

At the first command, the chiefs of subdivisions command as follows: The first: **Forward**. The second and third: **Front into line**. The fourth: **Mark time**. At the command march, the first subdivision continues the march in the full step; the second and third form front into line, each in succession resuming the full step at wheeling distance. The chiefs and guides resume their posts in column.

The square is also formed from column at half distance by the same commands and means.

To Form Square and Change Direction

327. Being in column of threes, to form square and change direction at the same time: 1. **Form square to the left**, 2. **MARCH**, 3. **Forward**, 4. **MARCH**, 5. **Guide left (right)**.

At the first command, the chief of the first section commands: 1. **First section**, 2. **Threes left**; the other chiefs caution, **forward**. At the command march, the first section wheels by threes to the left on moving pivots, and moves forward in the half step; the third, fourth, fifth, and sixth threes successively flank to the left; the third and fifth threes march across and form the right side of the square, while the fourth and sixth threes form the left side; the seventh and eighth threes wheel to the left on moving pivots, uniting in section, and constitute the base of the square, the chiefs giving the necessary commands. In this formation, the threes forming the sides of the square are left

in front. At the fourth command, all resume the full step. The officers and guides place themselves as in Par. 325.

To form column of threes from square and change direction to the right: 1. Form threes to the right, 2. MARCH, 3. Guide left.

At the first command, the leading guide places himself in front of the right file, the chief of the first section commands: 1. First section (platoon or company), 2. Threes right. At the command march the first section executes threes right; the right files mark time until the rear three of the first section passes, then moves forward into their place in the column by the right flank; the left files move forward into their place in the column, by the right flank; the fourth section takes one oblique step to the left, moves forward, and executes threes right into column.

The Triangle

328. The formation as here explained, is based on military principles, and does not conform strictly to the Ritual; for formation to conform to Ritual, see Manual of Asylum Ceremonies.

Being in march in column of threes: 1. Form triangle, 2. MARCH, 3. Forward, 4. MARCH, 5. Guide center.

At the first command, the chief of the first platoon commands: Right files into echelon, Par. 251, and places himself at the rear of number one of the rear three; the chief of the second platoon darts through the column and commands: Left files into echelon, and places himself in the position of the left guide, who covers number two of the rear three; the leading guide commands: 1. Center files, 2. Right and left front into line, and places himself twenty-one inches in front of number two of the leading three. At the command march, the leading guide takes the half step; numbers one and three of the leading three carefully preserve the interval between them, and the distance from the guide; the right files execute right into echelon, and the left files left into echelon, closing to twenty-one inches from the file in front, the chiefs

in rear verifying the positions of their respective divisions; the center files execute right and left front into line on number two of the leading three who marks time, gaining an interval of twenty-two

inches to the right; the files in rear, oblique left and right alternately, so that all numbers two of the left of sections are to the left, and all numbers two of the right of sections are to the right of the center interval, which is filled by the left guide, who exactly covers the leading guide, and preserves the alignment of the base of the triangle on the chiefs of platoons. The third guide takes post on the right of the base and the fourth guide on the left of the base, inside the platoon chiefs. The Commander takes position in the center of the triangle, and gives the fourth command when the formation is completed, when all resume the full step.

The Knights forming the sides of the triangle preserve with the greatest care the dis-

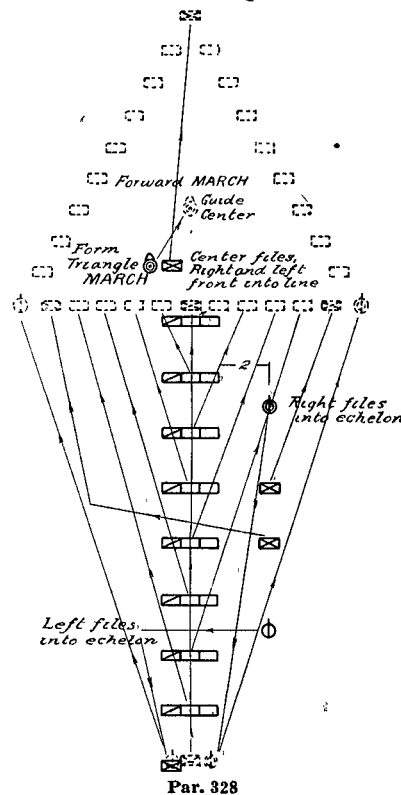

tance of twenty-one inches from the file in front, keeping their shoulders square with the line of direction.

If the Standard Guard be present, the Standard Bearer marches straight to the front, passing through the interval to be filled by the left guide, to a central position between the Commander and the left guide; the Sword Bearer and Warder oblique right and left respectively, and place themselves on the right and left of the base of the triangle. The above formation presents a perfect appearing triangle, with the tallest Knights at the apex and the center of the base, while the Knights at the angles are of uniform height.

329. To reform threes: 1. Form threes, 2. MARCH, 3. Forward. 4. MARCH, 5. Guide left.

At the command march, the leading guide places himself in front of number three and marches straight to the front in the half step; the flank files oblique on the center, taking the distance and trace from the file next in front; the left guide marks time until the left of the column approaches, when he places himself in rear of the left file; number two of the first three marches straight to his position in column, followed successively by the files on his left and right, the Standard Bearer, if present, steps into his position as his file leader passes him. The Sword Bearer and Warder oblique on the center, uniting with the Standard Bearer in proper position in column. The Commander gives the fourth command as the central files regain their position in column.

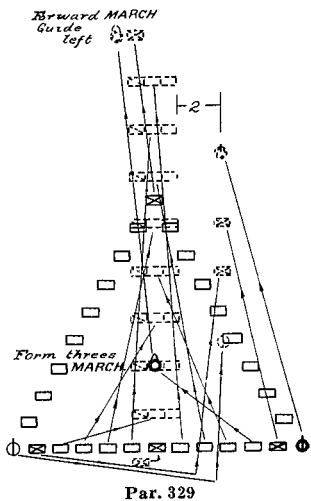

330. To change the base of triangle to the front: 1. Change base to front, 2. MARCH, 3. Forward, 4. MARCH, 5. Guide center.

At the first command, the left guide commands: 1. Center forward, 2. Files left and right.

At the command march, the leading files mark time; the leading guide executes to the rear and passes inside the triangle; the Knights forming the sides of the triangle march straight to the front, and successively mark time on gaining a distance of twenty-one inches to the front of the Knight preceding him in echelon; upon passing to the front, each Knight oblique a few inches toward the center of the triangle, in order that his shoulder may mask the shoulder of the Knight to his rear. The Commander marches straight to the front, passing through the apex of the new triangle to its right center; the Standard Bearer, if present, follows the Commander and marks time opposite him in the left center; the base of the triangle executes center forward, files left and right, and preceded by the left guide, passes through the apex between the Commander and Standard Bearer, when the guide takes the half step, and the base reforms front into line as before explained. The Commander gives the fourth command the instant the base arrives abreast of the chiefs of platoons, when all resume the full step. The Standard Bearer follows the trace of the leading guide, and the Commander follows the Standard Bearer. The right guide closes the apex of the triangle in the rear.

331. The triangle apex in front, may be formed from triangle base in front, in an inverse manner. The left guide leads the movement taking the half step, the base executing center forward, files left and right. The chiefs of platoons take the half step, the Knights advance and successively take the half step upon gaining twenty-one inches distance to the front of the file next preceding them in echelon. The right guide marches straight to the front and places himself at the apex of the triangle now changed to the front; the

Commander places himself in the right center, and the Standard Bearer in the left center, so that the base may reform in their rear.

The left guide, as soon as passed by the right guide, commands: 1. **Right and left front into line**, 2. **MARCH**, when the base reforms as before.

The Commander gives the command: 3. **Forward**, 4. **MARCH**, 5. **Guide center**, as soon as the right guide takes his post at the apex of the triangle, when the leading guide and the Knights in echelon resume the full step. The base resumes the full step and alignment when formed.

SCHOOL OF THE BATTALION AND REGIMENT

General Rules

The Battalion

332. A battalion is composed of two or more, not exceeding six commanderies or companies, under one Commander. Large commanderies may be formed into two or more companies of not less than twenty-four files each, as heretofore provided, Par. 178. When possible to do so, it is best to have the battalions composed of four commanderies or companies each, and in this school they will be so considered. In this school the terms "commandery" and "company" are synonymous.

While it is understood that the formation of the larger templar units will usually be confined to the ceremonies of grand commanderies, in the case of large commanderies, or where several commanderies are contiguous, permanent battalions or provisional battalions and regiments may be formed to the great interest and advantage of all concerned.

333. The senior officer present is the instructor, in the text he is designated as Battalion Commander. Since the battalion is not an administrative unit, the staff is usually limited to two, the Adjutant and the Sergeant Major.

334. When the commandery is formed as a battalion the Eminent Commander will assume his proper position as Battalion Commander, or will designate one qualified to do so, who may be the Generalissimo, the Captain General, a Past Commander, or other competent Sir Knight.

335. Companies in the same commandery may be designated by numerals or letters, as First, Second, Third, etc., or Co. "A", Co. "B", Co. "C", etc.

336. The following disposition of officers is suggested. The Generalissimo to command the First (right) company, the Captain General the Fourth (left) company, the

Senior Warden as Adjutant, the Junior Warden as Sergeant Major. Past Commanders for other company leaders.

NOTE—The Captain General is often made permanent Adjutant; the Senior Warden a company leader.

337. For ceremonies, and even for drills, it is better to equalize the commanderies by transferring Knights from the larger to the smaller, or by dividing large commanderies into two or more companies.

338. Commanderies take rank according to date of charter, and in forming battalion for ceremonies, are posted in order of rank from right to left in line and head to rear in column. For drill or maneuvers they take position as directed by the battalion commander.

Past Commanders and Past Grand Officers take rank according to the date of installation.

When two or more battalions appear for parade the formation will be that of a regiment.

The Regiment

339. A Regiment is composed of three battalions but these Regulations are applicable to a less or greater number. The senior officer present will command and will be designated Regimental Commander.

When the commandery is formed as a regiment the Eminent Commander assumes the command, under the title of Regimental Commander, or designates the Generalissimo or Captain General, a Past Commander, or other competent Sir Knight, to do so, the other officers of the commandery being proportionately increased in rank.

340. When several commanderies parade, they are under the authority of the Grand Commander, who if present, may assume command; in the absence of the Grand Commander, the ranking Grand Officer present, may assume the command; in the absence of any Grand Officer, the Grand Commander may name an officer to take command, as his representative, or failing to do so, the officers of the Commanderies present will elect a commanding officer. The commanding officer will designate the officers to command the several battalions, such officers appointing their own staff officers.

341. When the Grand Commander assumes command, unless otherwise ordered, the Deputy Grand Commander acts as Chief of Staff and Executive Officer; the Grand Senior Warden as Adjutant (Asst. Adjt. Genl.), the Grand Junior Warden as Sergeant Major, and the Grand Treasurer as Quartermaster, while the remaining Grand Officers and Past Grand Officers, take position on the staff of the Grand Commander; Past Grand Commanders on the left of the Grand Captain General.

342. The commanding officer and battalion commanders are designated field officers. The remaining Grand Officers and Past Grand Officers are designated staff officers.

343. The Grand Commander takes post in front of the center of the Regiment, a distance equal to about half its front. In column the Grand Commander with his staff rides at the head, twenty-four paces in front of the band. The staff is six paces in rear of the Grand Commander, formed from right to left as follows: Adjutant, other officers, according to rank, senior on the right. The Grand Standard Guard, with a trumpeter on its left, forms the rear line of the staff.

344. Field officers repeat commands whenever necessary; chiefs of commanderies, companies, and platoons only when prescribed.

345. All Grand Officers, and all field and staff officers, should be mounted, however, if not feasible to mount, all drills, ceremonies and parades of regiments and battalions may be executed on foot. At battalion drills the Adjutant and Sergeant Major should always be on foot. For street parades it is permissible for the Grand Commander and his staff to ride in carriages, the staff following in column in order of rank. Orderlies to mounted officers should be mounted.

346. Battalions in line are posted in order from right to left, and in column from head to rear, according to the rank of the commanders.

347. The interval between battalions in line is twenty-four paces.

EVOLUTIONS OF THE BATTALION

Position of Commanderies

348. Commanderies (companies) are designated numerically from right to left when in line, and from front to rear when in column, first commandery, second commandery, and so on. The numbers of commanderies change whenever by facing in the opposite direction, the left becomes the right of the line, and the rear the head of the column. If, in passing from line into column, the designation of commanderies is changed, they hold their line designation till the column is formed, when they take the column designation. In like manner, if in passing from column into line, the designation is changed, they hold the column designation till the line is formed when they take the line designation.

Chiefs of commanderies caution (such) commandery, whenever the designation is changed.

When the number of commanderies is even, those to the right of the center of the battalion, regardless of the position of the Standard, constitute the right wing, those to the left, the left wing.

In drill, the left commandery of the right wing is designated the right center commandery; the right commandery of the left wing, the left center commandery. The designation of wings changes whenever the battalion faces in the opposite direction.

When the number of commanderies is odd, the center commandery is part of the original right wing.

Battalion Standard

349. The battalion Standard Guard is posted as the left three of the right center commandery until the battalion line is formed; when the commandery is halted in rear of the guides the Standard Guard, under the command of the Sword Bearer moves into line and takes post midway between the right and left center guides facing the front. In line the Standard Guard is between the wings, the interval between it and the guides is two paces. In line of commanderies in column of threes, sections or platoons, the Standard Guard is

midway between the wings and on line with the chiefs. In close column the Standard Guard is on the left flank of the color commandery.

In column of commanderies, platoons or sections, the Standard Guard is midway between the wings and equidistant from the flanks of the column.

In column of threes, the Standard is midway between the wings, preserving a distance of three paces from the guide in front.

The Colors are delivered by the battalion commander into the hands of the Standard Bearers, and are escorted by the Standard Guard to the color-commandery, and in like manner escorted back. If, by movements of the battalion the Standard Guard finds itself not between the wings, it takes post there as soon as practicable.

The Standard Guard presents on receiving and parting with the colors; likewise the color commandery.

For Standard Guard in regimental formation, see Par. 411.

Posts of Officers and Battalion Staff

350. In line and in line of columns the battalion commander is posted about twenty paces in front of the center of the battalion; this distance to be reduced when the front of the battalion is less than sixty paces.

In column, he is on the side of the guide, abreast of its center and about twenty paces from it, or if in march, at the head. As instructor, he goes wherever his presence is necessary.

In column the Adjutant and Sergeant Major, each in his own wing, are on the side of the guide, opposite to and six paces from the head or rear of the column.

In line, the Adjutant and Sergeant Major are opposite the right and left of the battalion, six paces in rear of the file closers.

Chiefs of commanderies are posted three paces in front of their respective commands.

The staff officers, in order of rank from right to left, take posts three paces in rear of the Battalion Commander. In formations for battalion drill they are dispensed with. In

Par. 353

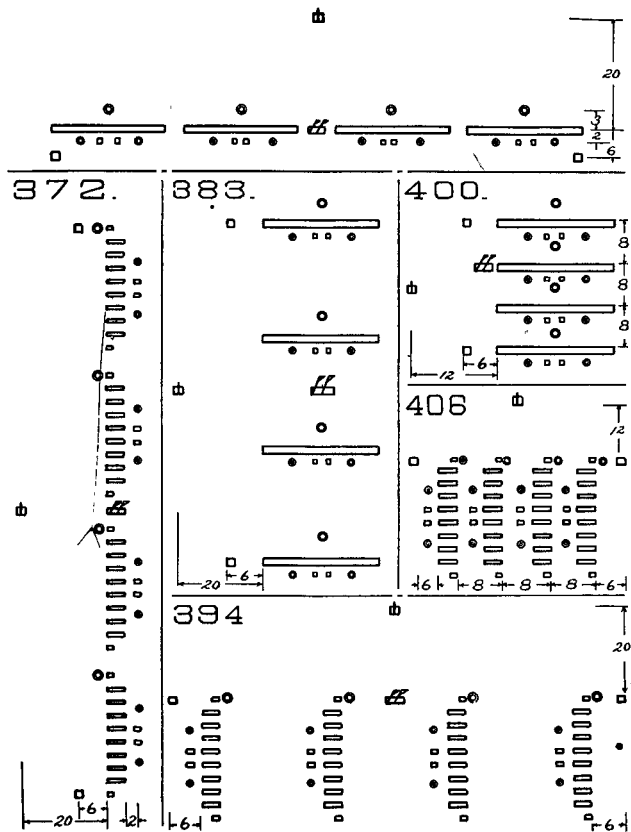

forming for street parade, they take post on the right of the battalion, six paces from its front rank.

The Band

351. The band is posted on the right of the battalion, the left of its front rank twenty paces to the right of the battalion.

Commands

352. Chiefs of commanderies repeat such preparatory commands as are to be immediately executed by their commands, as, **forward, threes right**, etc.

The Sir Knights execute the commands, **march and halt**, if applying to their commanderies, when given by the Commander.

Chiefs do not repeat the commands of the battalion commander, for the manual of the sword, nor those commands which are not essential to the execution of a movement by their commanderies as, **close in mass**, etc.

To Form the Battalion

353. At the sound of the assembly, the commanderies form on their respective parade grounds; being formed, Adjutant's call is sounded, at which the Senior and Junior Wardens (Adjutant and Sergeant Major), the latter on the left, and with swords in scabbards, march to the point where the base commandery is to form. The Adjutant posts the Sergeant Major on the line at a little more than commandery distance from and facing himself. Both then draw swords. If mounted the Adjutant proceeds to the point where the base commandery is to form; the Sergeant Major reports to him and is posted on the line, etc. The right and left guides of each commandery precede it on the line by about twenty paces, in double time, and are posted as markers, at guide swords, by the Adjutant and Sergeant Major. The guides of the color (right center) commandery are the first to arrive, and are posted on the line facing the left (point of rest). The line of markers is prolonged to the right by the right and left guides of the commanderies of the right wing who are

established facing the point of rest so that each is opposite the proper flank of his commandery when it is on the line; the left guide places himself about five paces from the right guide of the preceding commandery. The Adjutant aligns the guides in the right wing, placing himself in rear of the right guides as they successively arrive on the line. The line is similarly prolonged in the left wing by the Sergeant Major, who aligns the guides in their positions facing the right (point of rest), placing himself successively in rear of the left guides as they arrive on the line.

354. The guides, upon taking post on the line, bring their swords to the position of **guide swords**. Par. 111. This rule is general for all successive formations.

355. The color commandery (right center) is the first established, and is conducted by its chief so as to arrive from the rear, parallel to the line of markers. When it arrives at one pace from the line, the chief halts it, places himself near the left marker facing to the front, and dresses the commandery to the left, the breasts of the Knights opposite the markers resting against their arms; the commanderies of the right wing form successively from left to right, each being halted at one pace from the line and dressed to the left as explained for the color commandery. The commanderies of the left wing form successively from right to left, and are dressed to the right.

Each commandery is halted and dressed so there is an interval of three paces between the guides when in line.

356. When approaching a line, a commandery is halted by its chief when it is about one pace in rear of the line of markers.

When commanderies are to be aligned, chiefs place themselves on that flank toward which the dress is to be made, facing to the front. Par. 181.

Each chief, after dressing his commandery, commands: **Front**, and takes his post. These rules are general.

357. At the sounding of Adjutant's call, the band, if present, marches together with the commanderies to its position in line.

The battalion commander takes post, facing the line, and at a distance in front of its center, about equal to one-half its front.

358. The Adjutant having assured the position of the right guide of the right commandery, faces about, marches three paces to the right of the front rank, faces to the left, moves three paces to the front, faces to the left and halts, and, when the last commandery arriving on the line is brought to a front, commands: 1. **Guides**, 2. **POSTS**.

At the command posts, the Sergeant Major and guides take their posts in line.

The Adjutant moves at a trot (if dismounted, in quick time), by the shortest route to a point midway between the Commanders and the Battalion Commander, halts, faces about, brings the battalion to a present, resumes his front, salutes the Battalion Commander, and reports: **Eminent Sir (or Right Eminent Sir)**, the battalion is formed. The Battalion Commander returns the salute with the right hand, directs the Adjutant, **Take your post, Sir**, draws his sword and commands: 1. **Carry**, 2. **SWORDS**. The Adjutant faces about, and returns to his post by the same gait and path as described above.

359. The battalion may be formed in line on the right or left commandery by the same principles; the guides being posted facing the point of rest; or, it may be assembled in column of threes; when assembled the Adjutant reports to the Battalion Commander as soon as the last commandery has taken its place.

To Open Ranks

360. Being at a halt: 1. **Open ranks**, 2. **MARCH**, 3. **FRONT**.

The Battalion Commander remains in place facing the battalion. The Adjutant places himself facing to the left,

three paces to the right and three paces to the rear of the front rank. The chiefs of platoons and right and left guides and file closers take post as at the command **open ranks**, in the school of the commandery. Par. 191.

The Adjutant aligns the guides and then places himself facing to the left, in line with the Commanders, and three paces from the right flank.

At the command **march**, ranks are opened.

The commandery officers place themselves opposite their posts in line, three paces in front of the front rank, dress to the right, and cast their eyes to the front as soon as their alignment is verified. The Standard Guard, if present, stands fast dressing to the right. The band takes three paces between ranks, the alignment being verified by the drum major from the right.

The Adjutant verifies the alignment of the officers, both ranks, and the file closers, and then takes post facing to the front, three paces to the right of the battalion, in line with the officers. The Battalion Commander gives the command **front** when the Adjutant takes his post. The guides and drum major return to their posts in line. Should the battalion have wheeled about by threes, the Sergeant Major performs the duties of the Adjutant.

To Close Ranks

361. 1. Close ranks, 2. **MARCH**.

At the command **march**, the platoon leaders face outward and return to their posts in line, and ranks are closed. Par. 192.

To Rest the Battalion

362. 1. Battalion, 2. **REST**, or **AT EASE**.

To resume the attention, the Battalion Commander commands: 1. **Battalion**, 2. **ATTENTION**.

363. Dismiss your commanderies (companies), at which command, each Commander conducts his commandery to its parade ground, where it is dismissed, as prescribed in the

School of the Commandery. The Standard Guard escorts the colors to the quarters of the Commanding Officer.

To March in Line

364. The battalion being at a halt, and correctly aligned: 1. **Forward**, 2. **MARCH**, 3. Guide center (right or left).

At the second command the chiefs caution second (or such) commandery guide left (right) according as they are in the right or left wings. This rule is general.

At the command **march**, the battalion steps off promptly, guiding on the center; the Standard Bearer, charged with the step and direction, preserves with care the cadence and length of step, and selects points in advance on which to direct his march. The guides march abreast of the Standard Bearer, and in step with him.

The chiefs, in front of the centers of their commanderies, see that the guides preserve a general alignment, without abruptly shortening or lengthening the step, and that they preserve the interval of three paces between commanderies.

To effect a slight change of direction while marching, the Battalion Commander commands: **Incline to the right (left)** and indicates the new line of direction. The guide advances his left shoulder, giving time for the alignment to conform to his movement.

To Face the Battalion to the Rear and March It to the Rear

365. 1. Threes right (left) about, 2. **MARCH**, 3. Guide center (right or left).

At the second command the battalion wheels about by threes; each chief of commandery and file closer darts through the nearest interval to their new positions in line.

The Adjutant and Sergeant Major pass around the flanks to the rear of the line, and the battalion is maneuvered by the same commands and means as before.

Should the battalion be halted on completing the about by threes, each chief dresses his commandery to the left, com-

mands: **Front**, and places himself in front of its center. Should the battalion wheel by threes to the left about, the alignment would be to the right.

366. The battalion may be marched a few paces to the rear by the commands:

1. **Battalion**, 2. **About**, 3. **FACE**, 4. **Forward**, 5. **Guide center**, 6. **MARCH**; or, if in march, by the commands: 1. **To the rear**, 2. **MARCH**, 3. **Guide center**.

The officers, guides, Standard Bearer, and file closers retain their relative positions until the battalion is again faced to the original front, until which no other movement will be executed.

367. To put the battalion in march and to halt it; to march in the half step; to mark time; to change step; to march backward; to side step; to oblique; and to resume the direct march; to pass from quick time to double time, and the reverse, etc., are executed as explained in the School of the Commandery.

To Rectify the Alignment

368. Commanders, rectify the alignment. At this command, the chiefs to the right of the Standard hasten to place themselves on the left of their commanderies, and dress them successively to the left, each as soon as the chief on his left commands **front**; the chiefs to the left of the Standard place themselves on the right of their commanderies and dress them successively to the right; each chief returns to his place in line after commanding **front**.

369. To give the battalion a general alignment, the Battalion Commander moves outside one flank of the battalion, and commands: 1. **Guides, center (right or left) commandery on the line**, 2. **Guides on the line**, 3. **On the center (right or left)**, 4. **DRESS**, 5. **Guides**, 6. **POSTS**.

At the first command, the designated guides place themselves on the line, and face the center (right or left). Par. 111. The Battalion Commander establishes them by motion

of the sword in the direction he wishes to give the battalion.

At the second command, the guides of the other commanderies take the same posts as in forming battalions.

At the fourth command, the commanderies move up in quick time against the guides, where, having arrived, each chief dresses his commandery to the flank toward which his guides face.

If the new line be oblique, and at a considerable distance from the battalion, the chiefs remain in front of their commanderies, and conduct them with the guide toward the center, so as to arrive parallel to the line, where they halt and dress as before explained.

At the sixth command, guides return to their posts in line. If the new direction of the line be such that one of more commanderies find themselves in advance of it, the Battalion Commander, before establishing the guides, causes these commanderies to be moved to the rear.

To Pass Obstacles

370. Marching in line: 1. (Such) **Commandery (or Commanderies) obstacle**, 2. **MARCH**.

If the obstacle covers but one commandery, its chief commands: 1. (Such) **Commandery**, 2. **Left by threes**, or 2. **Right by threes**, according as he is on the right or left of the center; after repeating the command **march**, he places himself beside the leading three of his command, which continues to march in line. The guide of the commandery in line next toward the flank of the battalion, marches abreast of the basis of alignment, and preserves the interval necessary for the commandery broken to the rear to form again into line.

If the obstacle covers two commanderies not on the flank of the battalion, each breaks into column of threes, with the leading three of each commandery marching in line; the chief of the commandery farthest from the Standard places himself on the inner flank of the leading three, and preserves the

interval necessary for the two commanderies to reform into line. Par. 211.

371. When the obstacle is passed: 1. (Such) commandery (or commanderies) into line, 2. **MARCH**.

At the first command, the chief commands: 1. **Right (left) front into line**, 2. **Double time**.

At the command **march**, repeated by the chief, the commandery broken to the rear executes front into line in double time. If obstacles are passed in double time, the battalion is brought to quick time before reforming line. When marching in line, and obstacles are encountered covering a part of the commandery, its chief, without intimation from the Battalion Commander, breaks threes to the rear, causing them to reform line as soon as the obstacles are passed.

To March by the Flank

372. Being in line: 1. **Threes right (left)**, 2. **MARCH**.

The Battalion Commander marches about twenty paces from the center of the column, and on the side of the guide. The Adjutant and Sergeant Major march on the side of the guide, opposite to and six paces from the head or rear of the column, each in his own wing.

In extended marches, the Battalion Commander and staff is fifteen paces in front of the leading element of the column.

A distance of three paces is maintained between guides of adjacent commanderies, in column of threes or sections.

To Break into Column of Threes from the Right or Left to March to the Left or Right

373. Being in line at a halt: 1. **Column of threes**, 2. **Break from the right (left) to march to the left (right)**, 3. **MARCH**.

At the command **march**, the chief of the right commandery commands: 1. **Right by threes**.

At the command **march**, repeated by the chief, the commandery moves in column of threes to the front, its chief commanding: 1. **Column left**, in time to add: 2. **MARCH**, the

instant the leading three has advanced commandery distance; the guide then directs his march parallel to the front of the battalion.

The chief of the second commandery commands: 1. **Right by threes**, in time to add: 2. **MARCH**, the instant the leading three of the first commandery arrives opposite his right three; the leading three having marched commandery distance to the front, the commandery changes direction as explained for the first, and then follows in its rear; the other commanderies successively conform to what is explained for the second. See Par. 300.

To Form Line From Column of Threes to the Left or Right

374. 1. **Threes left (right)**, 2. **MARCH**, 3. **Battalion**, 4. **HALT**; or, 4. **Guide center (right or left)**.

The command halt, is given the instant the threes unite in line. Each chief hastens to place himself in the interval on the right of his commandery, facing to the front, dresses it to the right, commands **front**, and places himself in front of its center.

At the command, **guide center**, the battalion advances in line as explained in Par. 364.

General Rules for Successive Formations

375. Successive formations include all those formations where the several subdivisions arrive successively upon the line; such as **front into line**, the **deployments of columns**, **formations into line by two movements**, **changes of front**, etc.

(a) In all successive formations, except formation into line by two movements, the Adjutant and Sergeant Major, who is at the head of the column, or nearest the **point of rest**, establishes the two markers on the line opposite the right and left files of the subdivision first to arrive on the line. Both markers face toward the **point of rest**. If the formation be central they are placed on the line in front of the leading subdivision, facing to the center. Guides precede their commanderies on the line by about twenty paces, and in double time, and take the position of **guide swords**.

(b) In all formations from a halt, the markers are established at the preparatory command, indicating the direction in which the line is to extend; if marching, they hasten toward the point of rest at the preparatory command, and are established at the command **march**. In formation on right (left) into line, the first marker is established commandery distance to the right (left) of the head of the column.

(c) In formations front into line from column of threes or sections, they are posted commandery distance in front of the head of the column. In column of commanderies they are posted against the leading commandery.

(d) In the deployments, they are posted against the leading commandery or the head of the column, when the deployment is on the first subdivision; and six paces in front of the column, when the deployment is on a subdivision in rear.

(e) In changes of front, the first marker is posted commandery distance to the right of the first, or left of the fourth commandery according as the change of front is to the right or left.

The line is prolonged in the manner previously explained in formation of the battalion (Par. 353), by the guides of each commandery who are farthest from the point of rest; the guides are assured, as they successively arrive, by the officer at the head of the column, or nearest the point of rest. If the formation be central, the Adjutant and Sergeant Major establish the guides of their own wings. When the principles of successive formations are well understood, the guides may be required to post themselves as markers without assistance.

The Battalion Commander commands: 1. Guides, 2. **POSTS**, at the completion of all successive formations.
To Form From Column of Threes on Right or Left Into Line

376. Being in march: 1. On right (left) into line, 2. **MARCH**.

The first command is repeated by the chief of the first

Par. 376

On right into line

On right into line,
MARCH

20

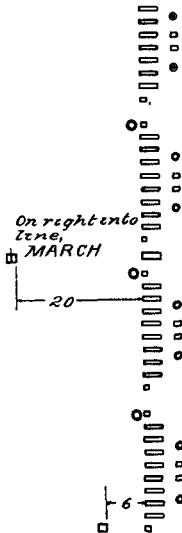

commandery. At the command **march**, repeated by the chief of the first commandery, it executes on right into line, Par. 205; its chief halting it at one

pace from the line when it dresses to the right against the markers. The other chiefs successively command: 1. **On right into line**, in time to add: 2. **MARCH**, when opposite the right of their places in line, halt their commanderies, when they dress as explained for the first.

The guides who are to mark the line remain with their commanderies until necessary to detach themselves in order to precede them on the line by about twenty paces.

Each commandery promptly dresses to the right without command, and when the last three has dressed, its chief gives the command **front**.

If the battalion be at a halt, the chiefs of commanderies in rear of the first, caution **forward**, at the first command of the Battalion Commander, and repeat the command **march**.

To Form the Column of Threes Front Into Line

377. Being in march: 1. Left (right) front into line, 2. **MARCH**.

At the first command, the chief of the first commandery commands: 1. **Left front into line**, 2. **Double time**; the chief of the second commandery commands: 1. **Column left**; the other chiefs: **Column half left**.

At the command **march**, repeated by all the chiefs, the

first commandery executes left front into line in double time, is halted at one pace from the line and dressed to the

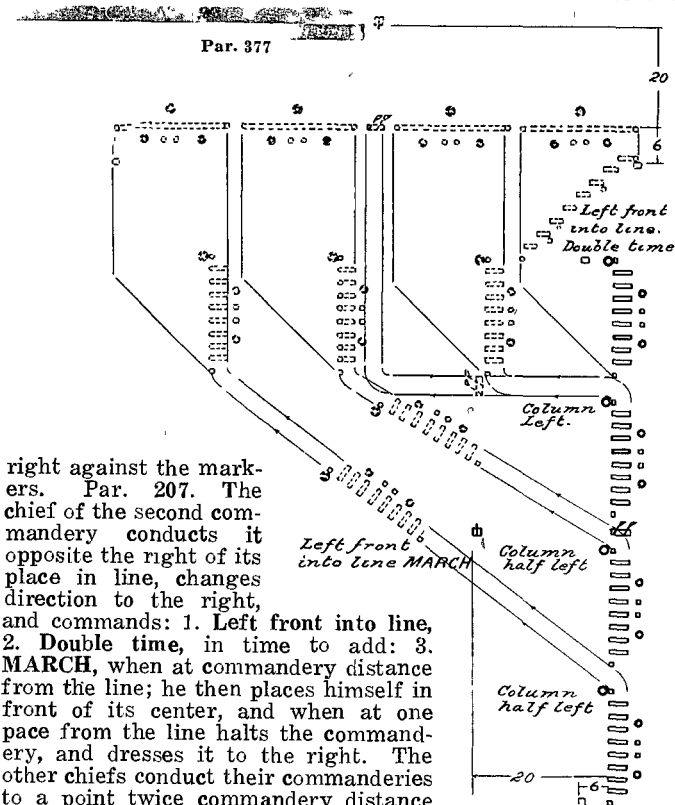

right against the markers. Par. 207. The chief of the second commandery conducts it opposite the right of its place in line, changes direction to the right, and commands: 1. Left front into line, 2. Double time, in time to add: 3. MARCH, when at commandery distance from the line; he then places himself in front of its center, and when at one pace from the line halts the commandery, and dresses it to the right. The other chiefs conduct their commanderies to a point twice commandery distance in rear of the right of their places in

line, change direction half right, and when at commandery distance from the line conform to what is explained for the second commandery. Each chief gives the command **front**, when the last three of his commandery has arrived on the line and dressed.

If at a halt, the chiefs of commanderies in rear of the first, prefix their commands by **forward**.

378. To form front into line faced to the rear: 1. Right (left) front into line, faced to the rear, 2. MARCH.

The movement is executed as explained in Par. 377, except that the chiefs do not halt their commanderies till they have marched three paces beyond the line; all the threes having arrived in line the chiefs wheel their commanderies to the left about by threes, halt them and then dress their commanderies to the right (left).

In forming line faced to the rear the threes wheel about toward the point of rest. This rule is general.

Formation of Column of Threes into Line by Two Movements

379. A part of the column having changed direction to the right to form line to the left: 1. Threes left, 2. Rear commanderies left front into line, 3. MARCH.

The chiefs whose commanderies have changed direction repeat the first and third commands, halt their commanderies as the threes unite in line and dress them to the right and take their posts.

The rear commanderies execute left front into line as previously explained, Par. 377. Guides are posted for the rear commanderies only.

To Form Double Column of Threes to the Front

380. Being in line: 1. Center forward, 2. Threes left and right, 3. MARCH.

At the second command, the chief of the right center commandery commands: 1. Left by threes, the chief of the left center commandery: 1. Right by threes; the other chiefs: Threes left or right, according as they are in the right or left wings.

At the command **march**, repeated by all the chiefs, the double column of threes is formed. The Standard Guard moves straight to the front, shortening the first three steps, the left three of the right wing and the right three of the left wing move straight to the front aligning on the standard guard; the file closers march in the interval between the wings.

The Battalion Commander marches on the right flank of the column twenty paces from the center. The Adjutant and Sergeant Major march in their own wings, abreast of, and six paces from the guides in rear of the column.

To Form the Double Column of Threes Front into Line

381. 1. Right and left front into line, 2. **MARCH**.

The movement is executed by each wing as explained in Par. 377. The markers are established for the leading commandery of the right wing as the base or point of rest.

To Form Double Column of Threes to the Right or Left into Line

382. 1. Threes right (left), 2. Left (right) commanderies on right (left) into line, 3. **MARCH**.

The chiefs of the right wing repeat the first and third commands, halt their commanderies as the threes unite in line, dress them to the left and take their posts. The commanderies of the left wing execute on right into line, Par. 376. The Sergeant Major in the left wing assures the guides of the left commanderies as they arrive on the line.

To Form Column of Commanderies to the Right or Left

383. Being in line at a halt: 1. Commanderies right (left) wheel, 2. **MARCH**.

At the first command, the chiefs of commanderies caution: **Right wheel**.

At the command **march**, each commandery wheels to the right on principles explained in Par. 193.

If the battalion be in march, at the command, **march**, the guides halt, and the wheel is completed as from a halt.

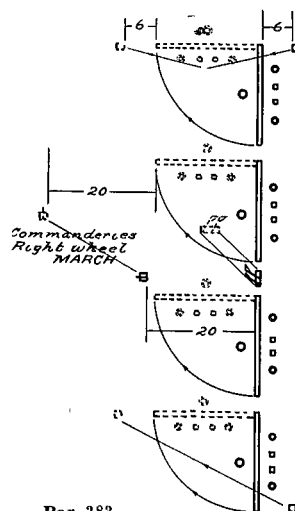

Par. 383

In column the Battalion Commander takes post on the flank toward which the commanderies are dressed, or if in march, on the side of the guide, about twenty paces from the center of the column. The Adjutant and Sergeant Major take post each in his own wing, abreast of, and six paces from the leading and rear subdivisions, and on the side of the guide.

On the march, the Battalion Commander and staff is at the head of the column 15 paces in front of the leading element.

Whenever the guide in column of commanderies or subdivisions is changed, the Adjutant and Sergeant Major, unless otherwise directed, pass by the most convenient route to the designated flank. **This rule is general.**

384. To break into column of commanderies and move forward without halting: 1. Continue the march, 2. Commanderies right (left) wheel, 3. **MARCH**, 4. Forward, 5. **MARCH**, 6. Guide right (left).

The commanderies wheel as before, except that the chiefs remain in front of their commanderies. At the fourth command, the right guides place themselves on the right of their pivot Knights.

The battalion breaks into column of platoons by the same commands and means as into column of commanderies, substituting in the command, **platoons for commanderies**. The chiefs of platoons at the first command, place themselves two paces in front of the centers of their platoons, and perform the same duties as the chiefs of commanderies.

To Break by the Flank of Commanderies to the Rear into Column

385. Being in line at a halt: 1. Right (left) of commanderies rear into column, 2. Threes right (left), 3. MARCH.

The movement is executed on principles explained in Par. 299.

The battalion breaks by platoon by the same command and means, substituting in the commands, platoons for commanderies.

To Break from the Right or Left to March to the Left or Right

386. Being in line at a halt: 1. Commanderies break from the right (left) to march to the left (right), 2. MARCH.

At the first command, the chief of the first commandery commands: 1. Forward, 2. Guide left.

At the command march, repeated by the chief, the right commandery moves forward, the chief commanding: 1. Left turn, in time to add: 2. MARCH, when the commandery has advanced commandery distance to the front, at which command, the guide faces to the left and marches on a line parallel to the front of the battalion, the commandery executing left turn as explained in Par. 196.

The second commandery executes the movement by the same commands and means as the first, its chief putting it in march when the first commandery arrives opposite its left; the left guide, after turning, marches in the trace of the left guide of the first. The other commanderies execute successively what is prescribed for the second; the chiefs giving their commands in time to avoid loss of distance.

To Change Direction in Column at Full Distance

387. Being in march: 1. Column right (left), 2. MARCH.

At the first command the chief of the first commandery commands: Right wheel.

At the command march, repeated by the chief, the lead-

ing subdivision wheels to the right, the chief adding: 1. Forward, 2. MARCH, upon its completion.

The other subdivisions march squarely up to the wheeling point, and change direction by the same commands and means as the first.

388. To put the column in march and change direction at the same time: 1. Forward, 2. Guide right (left), 3. Column right (left), or, 3. Column half right (half left), 4. MARCH.

To change direction slightly: Incline to the right (left). The leading guide slightly advances the left (right) shoulder, and comes gradually into the required direction, his subdivision conforming to his movements. The rear subdivisions execute the change of direction on the same ground, and in the same manner as the first.

To Form Line to the Left or Right from Column at Full Distance

389. Being at a halt, the guides covering each other at the proper distance: 1. Left (right) into line wheel, 2. MARCH, 3. Guides, 4. POSTS.

At the first command, the chiefs caution, left wheel; the right guide of the leading commandery places himself facing the leading guide of the column, at nearly commandery distance in front of him, so as to be opposite one of the right files of the commandery when the wheel is completed; the guide is assured in his position by the Adjutant or Sergeant Major at the head of the column.

The commanderies wheel to the left on fixed pivots; each chief of commandery faces his command to observe the wheel, moves toward the point where its marching flank is to rest, and, when it is near the line, commands: 1. Commandery, 2. HALT.

At the command halt, the commandery halts, the chief places himself on the line facing to the front, three paces from the left of the commandery next on the right, and com-

mands: 1. **Right**, 2. **DRESS**, 3. **FRONT**. At the command **dress**, the commandery dresses up to the line of guides.

At the fourth command, the guides take their posts in line.

A column in march is formed into line by the same commands as when at a halt; the guide, if not already there, being first ordered to the flank, toward which the movement is to be executed. At the command **march**, the guide on the marching flank of the leading subdivision places himself as previously explained; the guides halt in their places, and the Adjutant or Sergeant Major at the head of the column promptly rectifies his position; the subdivisions wheel on a fixed pivot as just explained.

390. To form line from column and move forward without halting: 1. **Continue the march**, 2. **Left (right) into line wheel**, 3. **MARCH**, 4. **Forward**, 5. **MARCH**, 6. **Guide center**.

At the third command, each commandery wheels as before explained, Par. 389, the right guide of the leading commandery remains on its right, and conducts the marching flank.

At the fifth command, the battalion moves to the front.

A column of platoons is formed to the right or left into line upon the same principles.

Being in Column at Full Distance on Right or Left into Line

391. Being in march, the Battalion Commander directs the guide, if not already there, to the flank toward which the movement is to be executed, and commands: 1. **On right (left) into line**, 2. **MARCH**.

At the first command, the chief of the first commandery commands: **Right turn**, and repeats the command **march**.

The commandery having arrived at one pace from the markers the chief halts it, and dresses it to the right. The other commanderies continue the march, each chief commanding: 1. **Right turn**, in time to add: 2. **MARCH**, upon ar-

riving opposite the right of his place in line. The commanderies are halted and dressed as explained for the first. See Par. 205.

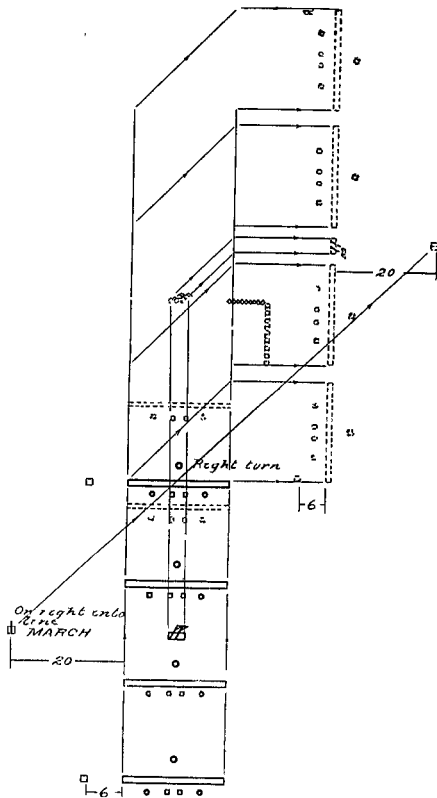

Being in Column at Full Distance Front into Line

392. Being at a halt: 1. Right (left) front into line, 2. **MARCH**.

At the first command, the chief of the first commandery commands: **Stand fast**. Each of the other chiefs commands: **Threes right**.

At the second command the chief of the first commandery dresses it to the left against the markers, the other chiefs repeat the command march and conduct their commanderies to the right. Each chief halts when opposite the point where the left of his commandery will rest in line, and when the rear three is abreast of him, commands: 1. **Threes left**, 2. **MARCH**, and conducts it to the line with **guide left**, halts, and dresses his commandery to the left.

The Standard Guard wheels to the right, advances and wheels to the left, and marches to its place in line.

Being in march the movement is similarly executed; the

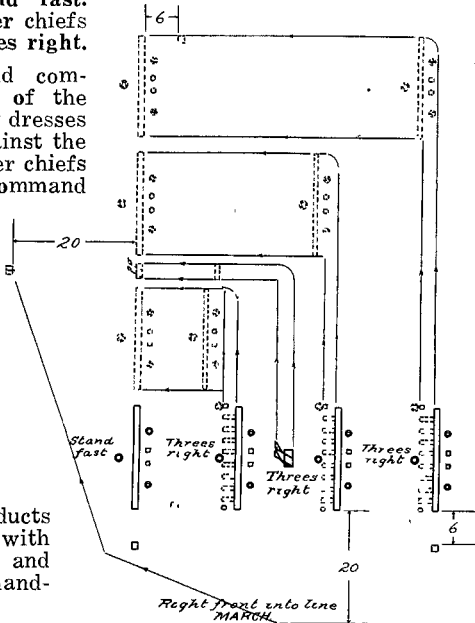

Par. 392

chief of the first commandery commands: **Commandery**, at the first command, and adds **halt** at the command **march**.

393. To form front into line faced to the rear, add the command: **Faced to the rear**, to the first command.

The movement is executed the same as Par. 392, except that the commanderies march three paces beyond the line and halt, and as soon as the guides close in, they wheel about by threes toward the **point of rest**, halt, and are dressed toward the point of rest.

To Advance in Line of Columns

394. The battalion being in line: 1. **Commanderies (Platoons, etc.)**, 2. **Right (left) by threes**, 3. **MARCH**, 4. **Guide right (left or center)**.

At the command **march**, each commandery or platoon executes **right by threes**.

At the fourth command, the guides of commanderies dress toward the right, left, or center, taking care to preserve the interval necessary to form front into line.

In the march in line of columns, the Battalion Commander marches twenty paces in front of the center of the battalion. The Adjutant and Sergeant Major march six paces outside the column, abreast of the chiefs of subdivisions, each in his own wing.

395. The battalion marching in line of columns is marched to the rear by the commands: 1. **Threes right (left) about**, 2. **MARCH**, 3. **Guide right (left or center)**.

The chiefs hasten to the heads of their commands, and the Adjutant and Sergeant Major face about and place themselves in the same relative position as when facing to the former front, and abreast of the leading guides.

Marching in Line of Columns to Form Line

396. 1. **Commanderies (Platoons)**, 2. **Left (right) front into line**, 3. **MARCH**, 4. **Battalion**, 5. **HALT**.

At the command **march**, each subdivision executes **left front into line**, and is dressed to the right by its chief.

If executed in **double time**, the Battalion Commander commands: **Guide center**, immediately after the command **march**.

397. Marching in line of columns, to march again in column of subdivisions: 1. Threes left (right), 2. MARCH, 3. Guide right (left or center).

Being in Line of Columns to Change Direction

398. 1. Change direction to the right (left), 2. MARCH, 3. Battalion, 4. HALT.

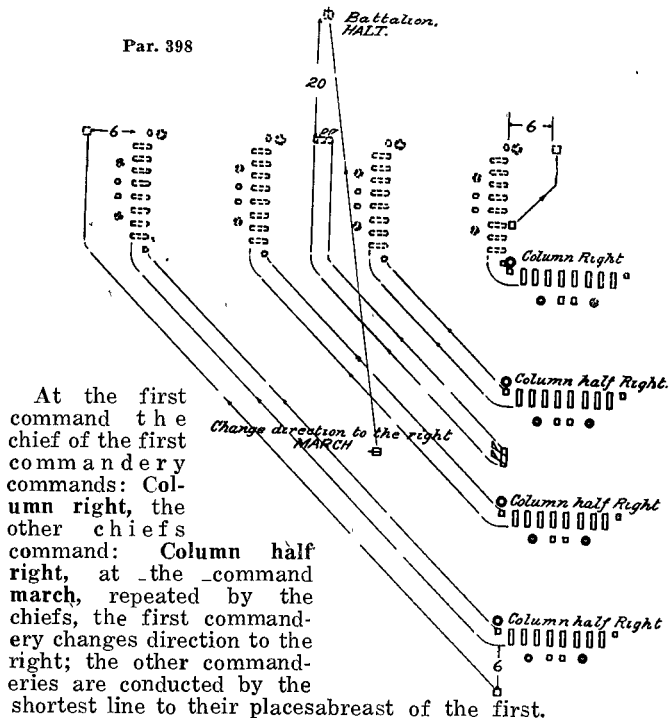

If marching in double time, or in quick time, and the command be **double time**, or being at a halt and the command be **double time**, the chief of the first commandery cautions: **Quick time**; the other commanderies execute the movement in double time, and on arriving abreast of the first commandery their chiefs command: 1. **Quick time**, 2. **MARCH**, and announce the guide. If the command halt be given during the execution of the movement only those commanderies that have arrived in place halt; the others successively halt upon arriving on the line.

If executed in double time, the Battalion Commander announces the guide immediately after the command **march**.

Formations in Mass

399. The Adjutant or Sergeant Major who is nearest the leading commandery, places himself in front of the guide at the point of rest and assures the guides of the other commanderies.

The distance between commanderies in mass is eight paces.

The chiefs are two paces in front of their commanderies; they resume their posts when full distance is taken.

Whenever a commandery takes its place in mass, the file closers close in one pace; they fall back to two paces when full distance is taken.

The Battalion Commander takes post twelve paces from the flank on the side of the guide.

Being in Column of Commanderies at Full Distance to Close in Mass

400. Being at halt: 1. Close in mass, 2. Guide right (left), 3. MARCH.

The chief of the first commandery cautions: **stand fast**; and dresses his commandery to the right (left); the other chiefs command: 1. **Forward**, 2. **Guide right**, the rear commanderies move forward; each is halted upon closing to eight paces; each chief establishes his guide in rear of the guide of the first, and dresses his commandery toward the guide.

If marching, the Battalion Commander omits the command for the guide, and the chiefs of the rear commanderies omit the command **forward**; at the command **march**, the first commandery is halted.

If marching in double time, or quick time, and the command be double time, the first chief cautions his commandery **quick time**; each of the other chiefs commands: 1. **Quick time**, 2. **MARCH**, upon closing to eight paces.

The Standard Guard takes position on the flank of the color commandery. This rule is general.

To arrest the march during the execution of the movement: 1. **Battalion**, 2. **HALT**. Only those commanderies halt that have closed to eight paces; the others halt successively at the commands of their chiefs; upon closing to eight paces. To close in mass on the rear commandery the Battalion Commander first faces the battalion to the rear by threes right (left) about, then closes as before.

Being in Mass to Take Full Distance

401. Being at a halt: 1. Take full distance, 2. **Guide right (left)**, 3. **MARCH**.

At the second command the chief of the first commandery commands: 1. **Forward**, 2. **Guide right**. Each of the other chiefs cautions stand fast and commands: 1. **Forward**, 2. **Guide right**, 3. **MARCH**, when his commandery has full distance. The Standard Guard resumes its position between the wings.

If marching in column closed in mass, the command for the guide is omitted, and at the command **march**, the chiefs of commanderies in rear of the first command: 1. **Mark time**, 2. **MARCH**, and successively command: 1. **Forward**, 2. **MARCH**, when at full distance.

If marching in double time, or in quick time and the command be double time, the first commandery takes the double time, the chiefs of the other commanderies command **quick time**, and successively command: 1. **Double time**, 2. **MARCH**, when at full distance.

Being in Column of Threes to Close in Mass to the Left or Right

402. 1. Close in mass, 2. **First commandery threes left (right)**, 3. **MARCH**.

At the second command the chief of the first commandery commands: 1. **Threes left**, and at the command **march** by the Battalion Commander repeated by the chief, the commandery forms line to the left, advances eight paces, is halted and dressed to the left. The chief of the second commandery halts in rear of the left of the first, and when the rear three is opposite him, forms line to the left, halts his commandery, establishes his left guide eight paces in rear of the left guide of the first, and dresses his commandery to the left.

Each of the other commanderies marches by the shortest line to a point eight paces in rear of the left guide of the preceding commandery, inclines so as to enter the column and execute what has been explained for the second commandery.

To Close in Mass to the Front from Column of Threes

403. 1. Close in mass, 2. **First commandery column right (left)**, 3. **MARCH**.

The first commandery changes direction to the right at the command **march**, its chief halts, and when its left is opposite him he commands: 1. **Threes left**, 2. **MARCH**; conducts his

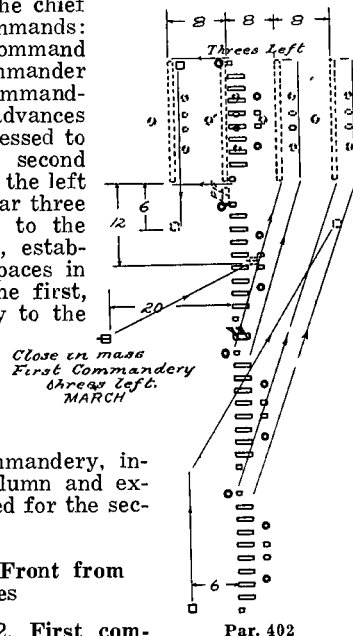

commandery eight paces to the front, halts and dresses it to the left; each of the other commanderies changes direction to the right so as to form line to the left and dress at eight paces from the preceding commandery. If the change of direction be to the left, the commanderies form line to the right and dress to the right.

The mass may be formed from line on the right or left commandery, by first marching in column of threes to the right (left), and then closing in mass as explained.

The mass may be formed faced to the rear by adding to the command, faced to the rear, after command, close in mass. The movement is executed, as previously explained, except that the commanderies in rear of the first successively enter the columns beyond a point where the first changed direction.

404. The mass is deployed on principles explained in Par. 392.

Being in Mass to form Column of Threes

405. Being at a halt: 1. Column of threes, 2. First (fourth or rear) commandery, threes right (left), 3. MARCH.

The designated commandery forms column of threes and marches to the right. Each of the other commanderies execute the same movement in time to join in column the one preceding, its chief conducting it by the most direct route.

Column of threes may be formed to the front on the same principles.

Movements in Mass

406. A column in mass advances, halts, obliques, marches by the flank, faces or marches to the rear, changes direction, etc., by the same commands and means as a column at full distance. Line is also formed to the front as in column of companies at full distance.

To Change Front

407. The battalion being in line: 1. Change front on

first commandery, 2. Commanderies right (left) half wheel, 3. MARCH, 4. Forward, 5. MARCH, 6. Guide right (left).

At the second command, the chief of the first commandery commands: Right wheel; the other chiefs command:

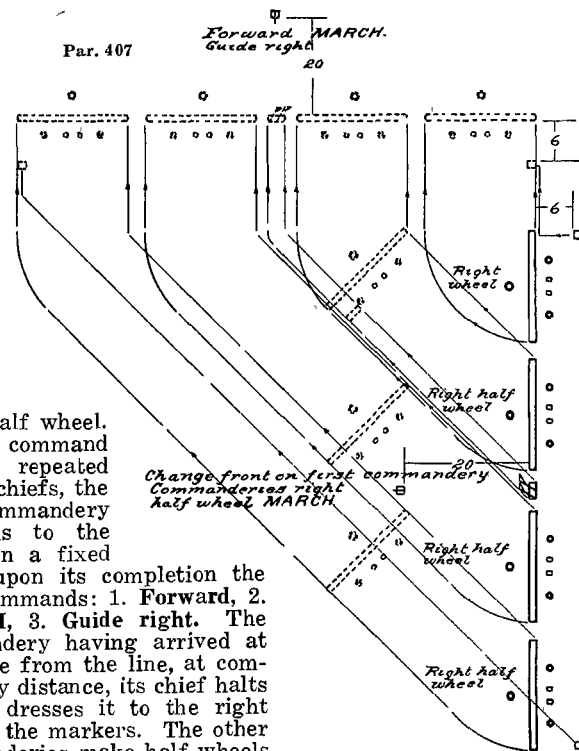

Right half wheel. At the command march, repeated by the chiefs, the first commandery wheels to the right on a fixed pivot; upon its completion the chief commands: 1. Forward, 2. MARCH, 3. Guide right. The commandery having arrived at one pace from the line, at commandery distance, its chief halts it, and dresses it to the right against the markers. The other commanderies make half wheels

to the right on fixed pivots, the chiefs repeating the fourth, fifth and sixth commands.

At the fifth command given the instant the commanderies complete the eighth of a circle, they cease to wheel, and march straight forward in echelon. The right of the second commandery, having arrived nearly opposite the left of the first, its chief commands: 1. **Right half turn**, in time to add: 2. **MARCH**, the instant the right of the commandery is opposite its place in line, halts it at one pace from the line and dresses it to the right. The others execute successively what is explained for the second.

Change of front on first (or fourth) commandery faced to the rear is executed on principles explained in Par. 393.

EVOLUTIONS OF THE REGIMENT

408. A line of

<table style="border: none;"> <tr><td style="border: none;">Battalions</td></tr> <tr><td style="border: none;">Companies</td></tr> <tr><td style="border: none;">Platoons</td></tr> <tr><td style="border: none;">Sections</td></tr> </table>	Battalions	Companies	Platoons	Sections	} in column of	<table style="border: none;"> <tr><td style="border: none;">Commanderies</td></tr> <tr><td style="border: none;">Platoons</td></tr> <tr><td style="border: none;">Sections</td></tr> <tr><td style="border: none;">Threes-</td></tr> </table>	Commanderies	Platoons	Sections	Threes-
Battalions										
Companies										
Platoons										
Sections										
Commanderies										
Platoons										
Sections										
Threes-										

is in general a line of masses, or line of columns.

A line of battalions each in mass is designated a line of columns.

Posts of Field Officers, Regimental Staff, Non-Commissioned Staff and Band

409. In line and in line of columns the Regimental Commander is posted sixty paces in front and opposite its center; in line of masses, thirty paces; in column he is twenty-four paces in front of the band.

In line of masses the posts of Battalion Commanders are twelve paces in front of their leading commanderies. The Staff is six paces in rear of the Regimental Commander; the Adjutant on the right, the other staff officers in order of rank from right to left; if but one staff officer be present, he takes post six paces to the rear and one pace to the right of the Regimental Commander.

Mounted trumpeters and orderlies are three paces in the rear of the staff.

In line, line of columns, and line of masses, the band is posted with the left of its front rank twenty-four paces to the right of the front rank of the first battalion; in column it marches with its rear rank twenty-four paces in front of the leading commandery, or its front rank twenty-four paces in rear of the rear commandery, according to the direction the column is facing.

The field music, if present with the band, forms in rear of it; when united, and the band is not present, it takes the post of and moves as prescribed for the band.

In all line formations, the non-commissioned staff officers, the Sergeant Major on the right, form at one pace apart, on the right of the non-commissioned staff of the first battalion; in column, the interval is such that the front of the combined non-commissioned staff is equal to the front of the column.

General Rules

410. The Regimental Commander gives his commands orally or by bugle or signal; or communicates them to the Battalion Commanders by staff officers or orderlies. Each Battalion Commander gives the appropriate command necessary for the proper execution of the movement. The Sir Knights wait for the battalion command before executing any movement.

Before directing a movement requiring the designation of a base battalion, the Regimental Commander commands orally or signals: **Guide right (left or center)**, which indicates respectively the right, left or center battalion as the base.

The base battalion, if in line or in line of columns, moves with guide center; if an interior one, and in column of companies, it moves with guide either right or left as announced by the Battalion Commander. The other battalions move with the guide toward the base battalion.

Each Battalion Commander in successive formations, gives the command **Guides posts**, when the guides of the next following battalion are on the line; if an interior and the

base battalion, when the guides of the last adjacent battalion have been posted.

Excepting in ceremonies, each battalion, by command of its Commander, stands at ease, while awaiting the completion of the general movement by the other battalions. The battalions are brought to attention by the Regimental Commander before executing another movement. When the desired formation admits of the simultaneous execution of movements by battalions or companies, the Regimental Commander may execute the movements prescribed in the School of the Battalion by prefixing **Battalions** or **Companies** to the commands.

Formation of the Regiment

411. The regiment is formed by battalions, either in line or in line of masses. It may also be formed in more than one line, and also in column or in line of columns.

The battalions are posted from right to left according to the rank of Battalion Commanders present, the senior on the right. A Battalion whose Commander is temporarily in command of the regiment retains its place in line. Except for ceremonies the battalions may be posted at the discretion of the Regimental Commander.

The Standard Guards, if more than one, remain with their respective battalions or if desired may be grouped with the second battalion. See Par. 152.

In whatever direction the regiment faces, the battalions are designated from the right when in line, from the head to rear when in column, first battalion, second battalion, etc. If in two lines, those in the first line are designated from the right, first and second; in the second line, third, etc.

In forming the line, the Adjutant indicates to the Adjutant of the base battalion the point of rest and the direction the line is to extend, and then takes post facing the line, about thirty paces in front of its center.

In forming in more than one line, the other battalions are posted as directed by the Regimental Commander, the

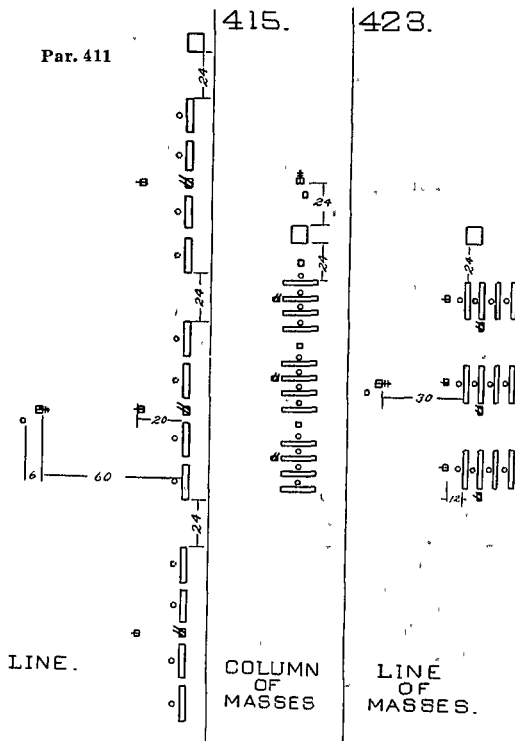

Adjutant, if necessary, indicating to the Battalion Adjutants their points of rest and direction. The non-commissioned staff takes post as the last battalion is formed. The formation completed, the Adjutant brings the regiment to attention, if not already there, by the commands: 1. **BATTALIONS**, 2. **ATTENTION**, and then commands: 1. **Present**, 2. **SWORDS**; each Battalion Commander brings his battalion to attention and present; the adjutant salutes the Regimental Commander and reports: **Sir, the regiment is formed**; the Regimental Commander returns the salute with the right hand, directs the adjutant: **Take your post, Sir**; draws sword and brings the regiment to the carry. The Adjutant takes post by passing by the Regimental Commander's right.

412. To dismiss the regiment, Open and Close Ranks, the Rests, Marchings, Halts, Alignments, Formations and movements in mass, are executed as described in the Evolutions of the Battalion, by each battalion, simultaneously or successively, at the command of its chief.

Successive Formations

413. The Adjutant or Sergeant Major of each battalion precedes it on the line to indicate the point of rest.

The guides of the leading commandery of the base battalion are the first established.

The guides of the leading commanderies of the rear battalions are established facing the point of rest of the regimental line, the nearest guide being twenty-four paces from the flank of the battalion next preceding it.

The distance in column of battalions, or when formed in two lines, is the front of a battalion in line and twenty-four paces; this may be increased or diminished, the Regimental Commander sending orders specifying the distance to the Commanders of the rear battalions, or sending a staff officer to indicate the points of rest.

Being in Column of Battalions to Form Front Into Line

414. 1. **Left (right) front into line**, 2. **MARCH**.

The first battalion stands fast or halts if in march; the

second is marched in columns of threes and forms line on the left of the first, and the third on the left of the second.

Column of Masses

415. In column of masses the distance of each battalion from the one preceding it is equal to the front of its first commandery. In forming column of masses, the rear battalions are dressed to the same flank as the leading battalion.

Being in Column of Threes or in Line, to Form Column of Masses

416. 1. **Column of Masses to the Left**, 2. **MARCH**.

The commander of the leading battalion ploys it in mass to the left, Par. 406. The commander of each of the other battalions marches it so as to enter the column commandery distance and eight paces in rear of the preceding battalion and there ploys it in mass.

From line, the column of masses is formed, facing to the front on the right commandery of the right battalion (left commandery of the left battalion) by first forming threes to the right (left) and proceeding as above.

To form the column of masses facing to the front or other direction, the Regimental Commander marches the columns of threes so that the leading commandery of the leading battalion is eight paces from the position he desires it to occupy when the column of masses is formed, and commands:

417. 1. **Column of Masses to the Front**, 2. **MARCH**.

The Commander of the leading battalion commands: 1. **Column right (left)**, 2. **MARCH**, 3. **Close in mass**, 4. **First commandery threes left (right)**, 5. **MARCH**, and proceeds as above.

418. The column of masses advances, halts, obliques, marches by the flank, resumes the march in column, faces or marches to the rear, and changes direction by the same means as when at full distance.

To Deploy the Column of Masses

419. Being in column of masses to form line to the front: 1. **Right (left) front into line, 2. MARCH.**

The first battalion forms front into line; as explained in Par. 388; the second forms on the right of the first, the third on the right of the second; the second and third may march in mass or in column of threes, the fourth commanderies in each battalion leading to their new positions.

420. To form line on the rear of the column, the Regimental Commander first faces the column to the rear, threes wheeling to the right about, and then executes the movement as explained.

Being in Column of Masses, to Deploy in Three Lines

421. 1. **Battalions, right (left) front into line, 2. MARCH.**

Each battalion forms right front into line.

Being in Column of Masses, to March to the Right or Left in Line of Battalions in Column of Threes

422. 1. **Battalions, first (fourth) commandery, threes right (left), 2. MARCH, 3. Guide right (left or center).** Each battalion marches in column of threes by moving the designated commandery in the direction indicated; the remaining commanderies successively follow the leading commandery inclining to the left or right.

Line of Masses

423. On all formations into line of masses, whether by simultaneous or successive movements, the Adjutant or Sergeant Major of each battalion posts the guides of the leading commandery, facing the point of rest.

To Form Line of Masses

424. Being in column of threes: 1. **Line of masses to the left (right), 2. MARCH.**

The Commander of the first battalion commands: 1.

Close in mass, 2. **First commandery threes left, 3. MARCH.** The others execute the same movement, each Battalion Commander commanding march, when the head of his column is twenty-seven paces from the flank of the preceding battalion.

425. Being in column of threes: 1. **Line of masses, right (left) front into line, 2. MARCH.**

The first battalion is closed in mass faced to the front, the leading commandery changing direction to the right; the other battalions are marched to the right front, and each executes the same movement so as to have an interval of twenty-four paces from the next battalion on its left.

426. Being in line, line of masses may be formed faced to the flank or front by first forming columns of threes and proceeding as prescribed above.

Being in Line of Masses, to Extend or Close Intervals

427. To extend intervals, the Regimental Commander designates the base battalion and commands: 1. **Extend, 2. MARCH.** The base battalion stands fast; the other battalions extend, marching by the flank and inclining slightly to the rear, and when they have gained the full interval, execute threes right or left and are halted on the line.

Intervals are closed on the same principles: 1. **Close, 2. MARCH.**

To Align the Line of Masses

428. If necessary to rectify the alignment, the Regimental Commander causes the guides of the first commandery of one of the battalions to be established on the desired line and commands: **Align your battalions.** The Adjutant or Sergeant Major of each of the other battalions posts the guides of the leading commandery on the established line; the Battalion Commanders dress their battalions toward the point of rest.

The first commandery of each battalion is dressed up to the guides; each of the other commanderies is dressed at close distance. If the new line is established at considerable dis-

tance from the battalions; each Commander moves his battalion to its new line before dressing it.

Movement of Masses

429. The line of masses advances, halts and faces or marches to the rear by the same commands and means as the regiment in line.

Being in Line of Masses, to Form Column of Masses Faced to the Front

430. 1. Column of masses on first (third) battalion, 2. **MARCH.**

The first battalion stands fast or is halted; the second is placed in mass in rear of the first, and the third in rear of the second.

If the third battalion be designated, the second takes position in rear of the third, and the first in rear of the second.

Each Battalion Commander may move his battalion into position in mass or in column of threes. The Adjutant or Sergeant Major of each battalion moves in advance to indicate the point where his battalion moves by the flank, or changes direction to enter the column of masses.

Being in Column of Masses, to Form Front into Line of Masses

431. 1. Line of masses, right (left) front into line, 2. **MARCH.**

The first battalion stands fast, or is halted; the second and third battalions are moved in mass or in column of threes to their places, the second on the right of the first, and the third on the right of the second.

Order in Echelon

432. Being in line at a halt, to advance in echelon, the Regimental Commander designates the base battalion and commands: 1. **Form echelon at (so many) paces,** 2. **MARCH.**

At the command march, the designated battalion advances in line, the other battalions stand fast; each is put in march when it has the specified distance from the one next preceding.

A file closer from each rear battalion marches at the specified distance directly in rear of the guide on the nearest flank of the preceding battalion; each rear battalion marches abreast of and preserves the interval of twenty-four paces from such file closer.

433. The regiment, in echelon, advances, halts, faces or marches to the rear or to the flank by the same commands as when in line.

Being in Echelon of Battalions to Form Line

434. The Regimental Commander designates the base battalion and commands: 1. **Form line,** 2. **MARCH.**

The designated battalion halts or stands fast; the others form on the line designated by moving to the front or rear.

A general alignment is given if necessary.

THE BRIGADE

Formation

435. The brigade consists of three regiments, but the rules here prescribed are applicable to a less or greater number. It is commanded by a Brigade Commander (Marshal). Regiments in line are designated right, center and left; or if one be in the rear, right, left and rear; in column they are designated leading, center and rear.

Unless otherwise directed by the Brigade Commander, the regiments are posted according to the rank of the Regimental Commanders, Par. 338; in line, from right to left, the senior on the right; in two or three lines by regiments, the senior in the first line, the junior in the rear line; in column, from head to rear, the senior at the head.

The interval between regiments is forty-eight paces.

In line the Commander takes post one hundred paces in front of the center of the brigade; in column at the head of the brigade.

The staff is six paces in rear of the Brigade Commander; in the following order from right to left: The Chief of Staff, Adjutant General, aids in order of rank.

The orderlies are three paces in rear of the staff.

The regulations for the evolutions of the regiment are applicable to the brigade. In moving into position, the regiments and battalions are habitually marched in column of three by the shortest practicable lines.

The Commander of the base battalion, when indicated, if marching, commands: **Attention**. Each of the other Commanders commands: **Attention**, on approaching the point where he gives his command for placing his battalion in position in the new formation. Each Battalion Commander commands **rest** when his battalion is in position.

REVIEWS

General Rules

436. In the review of large templar bodies, the reviewing officer and field and staff officers, non-commissioned staff and orderlies, are usually mounted. The same general rules and principles, however, will be followed in the review of all bodies of Knights Templar, large or small, indoors or out of doors, and whether mounted or dismounted.

The Adjutant posts men or otherwise marks the line of march of the column in such manner that its flank in passing will be about twelve paces from the reviewing officer.

The post of the reviewing officer is indicated by a marker.

Officers of the same grade as the reviewing officer or of higher grade, and distinguished personages invited to accompany him, place themselves on his left or as otherwise indicated; their staffs and orderlies place themselves, respectively, on the corresponding side of the staff and orderlies of the reviewing officer; all others who accompany the reviewing officer place themselves on the left of his staff or as otherwise indicated, their orderlies in rear. A staff officer is designated to escort distinguished personages and to indicate to them their proper positions.

437. While moving around the lines, the reviewing officer may direct that his staff and orderlies remain at the post of the reviewing officer, or that only his personal staff accompany him; in either case, the commanding officer alone accompanies the reviewing officer. While passing around the lines, the commanding officer is on the flank of the reviewing officer away from the command. If the reviewing officer is accompanied by his entire staff, the staff officers of the Commander place themselves on the side of the staff of the reviewing officer corresponding to the position of the Commander.

The reviewing officer and others at the reviewing stand salute the National Flag as it passes, whether the State Color

and Beauceant salute or not; those with swords not drawn salute by uncovering; when passing around the lines the reviewing officer and those accompanying him salute the National Flag when passing in front of it.

The reviewing officer returns the salute of the commanding officer of the lines only. Those who accompany the reviewing officer do not salute.

438. In passing in review, each staff salutes with its Commander. Without facing about, each subdivision leader commands: 1. **Eyes**, in time to add: 2. **RIGHT**, when at six paces from the reviewing officer, and commands: **FRONT**, when at six paces beyond him. At the command **eyes**, officers execute the first motion of present sword; at the command **RIGHT**, all turn the head and eyes to the right and the officers complete salute sword; at the command **FRONT**, all turn the head and eyes to the front, the officers resuming the carry sword. Knights in ranks do not salute.

The junior staff officers, junior officers in command of subdivisions and the drum major, salute, turn the head and eyes, return to the front, resume the carry or drop the hand at the points prescribed for the Battalion Commander. Officers and junior staff officers, with swords in scabbards, salute with the hand. Guides charged with step, trace, and direction, do not execute **eyes right**.

Sir Knights in conveyances, see Par. 164a.

439. After saluting the reviewing officer in passing in review, the commanding officer of the lines turns out of the column and takes post on the side of the reviewing officer toward the direction of march of the command; the members of his staff accompany him, take post on the corresponding side of the reviewing officer's staff. When the rear element of his command has passed, the commanding officer of the lines, without changing his position, salutes the reviewing officer; he and the members of his staff accompanying him then rejoin the command. The commanding officer of the lines and the members of his staff are the only ones who turn out of the column and take post at the side of the reviewing officer.

440. If the person reviewing the command is not mounted, the commanding officer and his staff, on turning out of the column after passing the reviewing officer, dismount preparatory to taking post. In such case, the salute of the commanding officer, prior to rejoining his command, is made with the hand before remounting.

441. When the rank of the reviewing officer entitles him to the honor, each beauceant and state color salutes at the command **Present swords**, given or repeated by the Commander of the battalion with which it is posted; and again in passing in review.

442. The band of an organization plays while the reviewing officer is passing in front and in rear of the organization.

During the march in review each band turns out of the column, takes post as hereinafter prescribed or as otherwise directed, continues to play until its regiment has passed, then ceases playing and follows in rear of its regiment; the band of the following regiment commences to play as soon as the preceding band has ceased.

While marching in review but one band in each brigade plays at a time, and but one band at a time when within 100 paces of the reviewing officer.

In large commands bands may be massed and posted as directed by the commanding officer.

If the rank of the reviewing officer entitles him to the honor, the band plays the prescribed national air or the field music sounds to the **color**, **march**, **flourishes**, or **ruffles** when arms are presented. See Par. 168. When passing in review, at the moment the State Color and Beauceant salute, the musicians posted with the band sound to the **color**, **march**, **flourishes**, or **ruffles**.

443. The present swords and the ride around the line by the reviewing officer may be dispensed with.

Templar formations march in review with the guide toward the flank on which the reviewing officer is posted. They pass in review in quick time only.

444. Whenever the colonel (Regimental Commander)

faces the line to give commands the majors (Battalion Commanders) face at the same time; they resume their front after seeing the movement executed. All such commands are executed when they have been repeated by the majors. When the command repeated is **Present swords**, the colonel's staff salutes at the command of the colonel; the major's staff salutes at the command of the major; the colonel and majors salute after resuming their front; each staff returns to the carry or order at the command of its chief. The same rules apply to the colonels and majors and to the Brigade Commander's, colonel's and major's staff whenever the Brigade Commander faces the line to give commands.

When passing in review, the staff of each Commander salutes and returns to the carry with him.

445. When the general (marshal), colonel, or major faces the line to give commands, the staff and orderlies do not change position.

446. In reviews of regiments or larger commands, each battalion and special unit, after the rear has passed the reviewing officer fifty paces, takes the double time for 100 yards in order not to interfere with the march of the column in rear, when necessary.

447. In a brigade or larger review, a Regimental Commander may cause his regiment to stand at ease, or fall out and resume attention, so as not to interfere with the ceremony.

448. When an organization is to be reviewed before an inspector junior in rank to the commanding officer, the commanding officer receives the review and is accompanied by the inspector, who takes post on his left.

449. The march in review may commence from either flank of the command. When the march is to commence with the left flank, the command should be formed from left to right. The march in review is described in these Regulations as commencing with the right flank; appropriate changes in commands and movements are made when the movement is to commence with the left flank.

COMMANDERY REVIEW

450. A separate commandery is reviewed upon the same principles as explained for the battalion, the commandery being first formed as for public parade, see Par. 147. The commandery marches in column of platoons, sections, or threes, the Commander and chiefs of subdivisions, conform to the duties of the Battalion Commander and the Commanders.

BATTALION REVIEW

451. The field and staff are usually dismounted, unless the reviewing officer be mounted.

When the Battalion Commander is the reviewing officer, the senior Commander or the Adjutant or a Past Commander, will be designated to command the lines.

The battalion being in line, the Battalion Commander commands: 1. **Prepare for review**, 2. **Open ranks**, 3. **MARCH**, 4. **FRONT**.

Ranks are opened as explained in Par. 360, the Adjutant taking post on right of the staff at command **front**, when the major (Battalion Commander) commands: 1. **Present**, 2. **SWORDS**, faces about, and salutes. If the rank of the reviewing officer entitles him to it, the State Color will salute, and the trumpeters sound a march, or the flourishes, see **Honors paid by Templars**, Par. 168. The reviewing officer acknowledges the salute, after which the Battalion Commander commands: 1. **Carry**, 2. **SWORDS**, 3. **Order**, 4. **SWORDS**, faces to the front, and stands at attention, and when the reviewing officer approaches to about six paces, he salutes with the sword and joins him taking post on his right, and accompanies him around the battalion; the staff remains in place at attention.

The reviewing officer proceeds to the right of the line, passes in front of the officers to the left of the line, returns to the right, passing in rear of the file closers. The reviewing officer and those accompanying him salute the National Flag when passing in front of it. The band plays while the reviewing officer is going around the battalion, ceasing to

play when he leaves the right to return to his station. On arriving again at the right of the line, the Battalion Commander salutes, halts, and when the reviewing officer and staff have passed, moves directly to his post in front of the battalion, faces it, closes ranks, and commands. 1. **Threes right**, 2. **MARCH**, 3. **Battalion**, 4. **HALT**, 5. **Pass in review**, 6. **MARCH**.

At the sixth command, the column moves off, the band playing; without command from the Commander of the battalion, the column changes direction at the points indicated, and column of commanderies is formed successively at full distance at the second change of direction with guide right, each Commander successively commanding: 1. (Such) **Commandery**, 2. **Threes left**, 3. **MARCH**, 4. **Guide right**. The Battalion Commander and staff take post fifteen paces in front of the band immediately after the second change in direction, the Adjutant and Sergeant Major are on the side of the guide, and six paces from the flanks of the leading and rear commanderies; the band having passed the reviewing officer wheels to the left out of the column, and takes post in front of and facing the reviewing officer, where it remains till the rear of the column has passed, when it returns to its place before the review, ceasing to play as the battalion approaches its original position. The Battalion Commander and staff, except the Adjutant, salute together when he is six paces from the reviewing officer, and return to a carry when six paces beyond him. The other officers salute and return to the carry at the points prescribed for the Battalion Commander. In saluting all officers turn the head and look toward the reviewing officer. Without facing about, each Battalion Commander commands: 1. **Eyes**, 2. **Right**, at six paces from the reviewing officer, and 3. **Front**, when six paces past him. If entitled to a salute from the State Color it salutes when six paces from the reviewing officer, and is raised when six paces beyond him; as the State Color salutes, the trumpeters sound a march, or the flourishes, according to his rank, the band continuing to play. The commanding officer acknowledges only the salute of the Battalion Commander and of the State Color.

The Battalion Commander, having saluted, places him-

self on the right of the reviewing officer, Par. 439, where he remains till the rear of the battalion has passed, when he salutes and rejoins the battalion. The head of the column having executed a second change of direction to the left, after having passed the reviewing officer, may occupy its original ground, or may be marched to quarters and dismissed.

REGIMENTAL REVIEW

452. The regiment is formed in line or line of masses.

The review proceeds as in the battalion, substituting "Colonel" (Regimental Commander) for "Major" and "regiment" for "battalion."

At the Colonel's command, **Present Swords**, the major of the center battalion commands: 1. **Present**, 2. **SWORDS**. The other majors successively from the center bring their battalions to present swords. Order swords is similarly executed.

To march the regiment in review the Colonel commands, orders or signals, **Pass in Review**. The major of the right battalion then commands: 1. **Column of threes**, 2. **First Commandery threes right**, 3. **MARCH**, and proceeds as in battalion review. Other majors successively move their battalions by similar commands, in time to follow the preceding battalion at battalion distance. The band and commanderies change direction without command from the majors and pass in review as prescribed for battalion review.

At the second change of direction, each major takes post fifteen paces in front of his leading commandery, and the Colonel and staff take posts twenty paces in front of the band immediately after the second change of direction.

The rear of the column having passed the reviewing officer, the battalions, unless otherwise directed, are marched to their parades and dismissed.

Should it be desired to form in mass and march past in close line, the provisions of the U. S. Infantry Drill Regulations should be followed in battalion or regimental reviews, also in reviews of the brigade or larger bodies. For massed column, see Par. 457.

PARADES

COMMANDERY PARADE

453. At Adjutant's call the line is formed, with the Standard Guard, as for Public Parade, Par. 147; without reporting to the Commander.

The Adjutant (Senior Warden) then proceeds as in Battalion Parade; directing the chief of the first platoon; **Sir, the line is formed**; the platoon chiefs also report their respective platoons, at the command **Report**, by the Adjutant.

The Commandery is marched in review in column of platoons or sections.

BATTALION PARADE

454. Five minutes after the first call, or such interval as may be prescribed by the commanding officer, the assembly is sounded by the buglers, united, at which the commanderies form on their respective parade grounds and are informally inspected by their Commanders. At the Adjutant's call, the band plays in quick time, and if not already there, marches to its post in line, continuing to play until the last commandery is formed. The line is formed as explained in Par. 353-358.

The Battalion Commander takes his post, and during the sound off, stands at **parade rest**, with arms folded, coming to attention with the Adjutant preparatory to the playing of the Star Spangled Banner; or, if the parade be not at retreat, he comes to attention with the Adjutant before ranks are opened.

The staff, except the Adjutant, is three paces in his rear.

The Adjutant, after commanding: **Guides posts**, informs the Commander of the first commandery: **Sir** (prefacing with proper honorary title), **the line is formed**. The Commanders, commencing at the right, successively face about and command: 1. (Such) **Commandery**, 2. **Order**, 3. **SWORDS**, 4.

Parade, 5. **REST**, resume the front and take the position of **Parade rest**.

The Adjutant then faces to the front and commands: **SOUND OFF**, and takes the position of **parade rest**.

The band, commencing on the right, plays in quick time, passing in front of the Commanders, to the left of the line, countermarches and returns to its post on the right; at evening parade, after the last strain is finished, **retreat** is sounded by the buglers, and just before the last note of retreat the Adjutant comes to attention, faces to the left, and, as the last note ends, commands: 1. **Battalion**, 2. **ATTENTION**, 3. **Carry**, 4. **SWORDS**, 5. **Present**, 6. **SWORDS**, resumes his front, and salutes, retaining that position until the last note of the National Anthem, when he faces to the left and commands: 1. **Carry**, 2. **SWORDS**, 3. **Open Ranks**, 4. **MARCH**, 5. **FRONT**.

After the fifth command, he passes to a point midway between the battalion and the Battalion Commander, where he halts, faces about, and commands: 1. **Present**, 2. **SWORDS**.

NOTE—Should the rank of the officer receiving the parade entitle him to the honor, the State Color, if present, salutes.

The Adjutant then faces about, salutes, and reports: "**Sir!** (giving proper honorary title) **The parade is formed.**" The Battalion Commander returns the salute with the right hand, and directs the Adjutant "**Take your post, Sir.**"

The Adjutant takes post three paces to the rear and one to the right of the Battalion Commander, passing by his right. If the staff be present he takes post on its right.

The Battalion Commander draws sword, and commands: 1. **Carry**, 2. **SWORDS**, and adds such exercises in the Manual of the Sword as he may desire, concluding with **carry swords**.

NOTE—The officers and Standard Guard having once executed **carry swords**, remain in that position during the exercises in the manual.

He then directs the Adjutant: "**Receive the reports, Sir.**" returns his sword and stands at attention.

The Adjutant, passing by the right of the Battalion Com-

mander, advances to a point midway to the line of the officers, halts and commands: **REPORT**. The Commanders, in succession from the right, salute, then report: **First** (or such) **Commandery present or accounted for**, or (so many) **Knights absent**. The Adjutant returns the salute of the Commanders. The reports made, the Adjutant faces about, salutes, and reports: **Sir, all are present or accounted for**, or, **Sir** (so many) **officers or Knights are absent**; including in the absentees those from the musicians reported to him by the Drum Major prior to the parade.

The Battalion Commander returns the salute, and directs: "**Publish the orders, Sir,**" when the Adjutant faces about, and commands: **Attention to orders**.

He then reads the orders, after which he commands: 1. **Officers**, 2. **CENTER**, 3. **MARCH**, and takes his post.

At the command, **Center**, all the officers face toward the center; at **March**, all step off at the same time, close on the center, halt, and successively face to the front. All the officers having faced to the front the senior commands: 1. **Forward**, 2. **Guide Center**, 3. **MARCH**.

At the third command, they march to the front, the band playing in quick time: on approaching the Battalion Commander, the senior commands: 1. **Officers**, 2. **HALT**.

At the command **halt**, given at six paces from the Battalion Commander, the music ceases, the officers halt, and salute with the sword. The salute being acknowledged, they resume the carry with the Battalion Commander.

The Battalion Commander gives such directions as he may deem necessary, and commands: 1. **Officers**, 2. **Posts**, 3. **Guide center**, 4. **MARCH**.

At the command **posts**, the officers face about. At **march**, they step off and when three paces from the line the senior commands: 1. **Officers**, 2. **HALT**, 3. **Posts**, 4. **MARCH**.

At the command **posts**, officers face outward, and at **march**, step off in succession at four paces distance, resume their posts and **order swords**.

The music ceases when all officers have resumed their posts.

The Battalion Commander then closes ranks, and com-

mands: 1. **Threes right**, 2. **MARCH**, 3. **Battalion**, 4. **HALT**, 5. **Pass in review**, 6. **MARCH**, and returns his sword.

NOTE—If a senior officer is to receive the review, the Battalion Commander now moves forward and commands the lines.

At the sixth command the column moves off, the band playing. The column changes direction at the points indicated, without command from the Battalion Commander (Commanders giving the necessary commands). The battalion marches as in review, Par. 451.

A column of commanderies (or platoons), at full distance with guide right, is formed successively to the left at the second change of direction. Each Commander successively commands: 1. (Such) **Commandery**, 2. **Threes left**, 3. **MARCH**, 4. **Guide right**. The battalion marches past according to the principles of review; when the last commandery has passed, the ceremony is concluded. The band having passed the reviewing officer, turns to the left out of column, takes post in front of and facing the reviewing officer, and remains there playing until the review terminates.

Without facing about, each Commander commands: 1. **Eyes**, in time to add: 2. **RIGHT**, when at six paces from the reviewing officer, and commands **FRONT**, when six paces beyond him. Commandery officers execute the first motion of **present** at the command **eyes**, at the command **right**, all turn the head and eyes to the right, and the officers complete **salute swords**.

At the command **front**, all turn the head and eyes to the front, officers resuming the **carry**.

Guides charged with the step, trace, and direction do not execute **eyes right**.

If the reviewing officer is entitled to a salute from the State Color, it salutes when at six paces from him and is raised when six paces beyond him, he returns only the salute of the Battalion Commander, and the State Color or Beauceant; the Battalion Commander, having saluted, takes post on the right of the reviewing officer, remains there until the rear of the battalion has passed, then salutes and rejoins the battalion; the band ceases to play and the ceremony is ended when the rear commandery has passed the reviewing officer.

REGIMENTAL PARADE

The regiment is formed in line or in line of masses.

In Line

455. At the assembly, the commanderies are formed and inspected.

At Adjutant's call, each battalion is formed in line, on its own parade ground; the battalion adjutant takes his post in front of the center and receives the reports of the Commanders as prescribed in battalion parade. When the battalions are formed, Adjutant's call is again sounded; the regiment is then formed in line, each Battalion Commander opening ranks in his battalion as soon as it is formed on the line, regulating on the base battalion; each battalion adjutant takes post on the right of the staff of his Commander.

The Adjutant after indicating to the Adjutant of the base battalion the points of rest and direction the line is to extend, takes post facing to the left, six paces to the right of the first commandery of the base battalion and in line with the Battalion Commanders, and draws sword; when the line is formed, he informs the first battalion commander: **Sir, the line is formed: the Battalion Commanders in succession bring their battalions to parade rest.**

The Adjutant then turns to his left and commands, **Sound off**, and takes his post, facing to the front. The band, playing in quick time, passes in front of the Adjutant and field officers to the left of the regiment and back to its post on the right, when it ceases playing.

When the parade is at **retreat**, the Adjutant turns to the left as the last note of **retreat** is sounding, and, when it is finished, commands: 1. **Battalions**, 2. **ATTENTION**, 3. **Carry Swords**, 4. **Present swords**, and resumes his front; the Battalion Commanders bring their battalions to **Present swords**; the band plays *The Star Spangled Banner*. When the music ceases the Adjutant turns to the left and commands: 1. **Carry**, 2. **SWORDS**, then moves at a trot in front of the line of field officers to the center of the regiment, turns to the right and halts at a point midway between the commanding officer and the line, facing the regiment and commands: 1. **Present**, 2.

SWORDS; faces the commanding officer, salutes, and reports: **Sir, the parade is formed.** The commanding officer returns the salute and directs the Adjutant: **Take your post, sir.** The Adjutant takes his post on the right of the staff, passing by the commanding officer's right.

The commanding officer draws sword and commands: 1. **Carry swords**, and adds such exercises in the manual of the sword as he may desire, concluding with **Carry swords**. The commanding officer then directs the Adjutant to **receive the reports**.

NOTE—The battalion is the largest unit habitually receiving oral commands. For example the Regimental Commander commands: "**Carry Swords**," which movement will then be executed by the battalions, simultaneously or successively, at the command of their respective chiefs.

The Adjutant advances by the right of the commanding officer toward the line, halts midway between the commanding officer and the line of the Battalion Commanders and commands: 1. **Adjutants**, 2. **Front and center**, 3. **MARCH**, or, 3. **Trot**, 4. **MARCH**.

At the command **March**, the Battalion Adjutants move three paces to the front of the line of Battalion Commanders, close to the center and face to the front. The Adjutant then commands: **Report**, when the Battalion Adjutants, commencing on the right, salute and report: **First (or such) battalion, present or accounted for**; or, **First (or such) battalion, (so many) officers and Sir Knights are absent**.

The Adjutant returns the salutes of the Battalion Adjutants. The reports concluded, the Adjutant commands: 1. **Adjutants**, 2. **Posts**, 3. **MARCH**, or, 3. **Trot**. 4. **MARCH**. Each Battalion Adjutant returns to his post on the right of the staff of his Battalion Commander.

The Adjutant then faces the commanding officer, salutes and reports: **Sir, all are present or accounted for**, or, **Sir, (so many) officers and Knights are absent**, including in the absentees those from the band and field music reported to him by the drum major before the parade.

The commanding officer returns the salute and directs: **Publish the orders, Sir.**

The Adjutant faces the regiment, and after publishing

the orders, commands: 1. Officers, 2. Center, 3. MARCH, and takes post as before on the right of the staff. At the command center, the commandery officers face toward the center, each battalion staff forms line on the left of its Commander.

At the command march, the commandery officers close to the center and face to the front. The field officers and their staffs move by the flank to the right and left on their own line; those of the first battalion form in line six paces to the right of the line of the commandery officers; those of the second and third battalions form in line six paces to the left of the line of the commandery officers.

The commandery officers having closed and faced to the front, the senior Commander commands: 1. Forward, 2. Guide center, 3. MARCH.

The commandery officers advance, the band playing, the left officer of the right wing of the second battalion, or the left officer of the first battalion, if there be but two battalions, is the guide and marches on the Regimental Commander.

When the commandery officers have advanced to the line of field officers, the field officers and their staffs advance in line with the commandery officers.

The line is halted at six paces from the commanding officer by the senior officer, who commands: 1. Officers, 2. HALT. The officers halt and salute, returning to the carry with the Regimental Commander, who then gives such instructions as he deems necessary, and commands: 1. Officers, 2. Posts, 3. Guide Center, 4. MARCH.

At the command posts, commandery officers face about; at the command march, they step off, and when three paces from the line the senior commands: 1. Officers, 2. HALT, 3. Posts, 4. MARCH.

At the command posts, they face outward, and at the command march, step off in succession at four paces distance, and resume their posts and order swords.

At the command march from the Regimental Commander, each Battalion Commander moves individually to the front, turns outward, and followed by his staff, takes his post by the most direct line. The music ceases when all officers have resumed their posts.

The Regimental Commander then closes ranks and commands: 1. Threes right, 2. MARCH, 3. Battalions, 4. HALT. 5. Pass in review, 6. MARCH, and returns his sword. The regiment is then marched in review, which concludes the ceremony.

At the second change of direction, each Battalion Commander takes post fifteen paces in front of his leading commandery. The commanding officer precedes the band or the leading Battalion Commander twenty paces.

In Line of Masses

456. The line is formed as prescribed in the Evolutions of the Regiment. The colors form on the left of the leading commandery of the center (right center) battalion. It rejoins the color commandery when the regiment changes from line of masses.

Ranks are not opened, and Commandery officers do not march to the center; otherwise no change from parade in line. (See U. S. Infantry Drill Regulations.)

STREET PARADE

457. Street parades, especially those of the Grand Bodies, are ordinarily commanded by a Sir Knight designated as "Marshal" or "Grand Marshal." (May be the Captain General or Grand Captain General.)

The Grand Marshal appoints a chief of staff and aides, and issues a general order giving all necessary directions for the formation, movement and dismissal of the parade.

This order should publish:

1st. The names of his staff officers, and when and where they should report to him.

2nd. The names of the marshals of divisions and commanders of brigades, etc.

3rd. The assignment of organizations to their positions in column.

4th. The streets upon which the different divisions and brigades will form, the direction in which their lines face, where the right will rest, and the size of the front of the subdivisions in column.

5th. The time for each division to complete its formation and be ready to march.

6th. The time and place from which the head of the parade will move, and the line of march and place of review.

7th. Honors to be paid by the command during the march.

8th. Instructions regarding uniform.

9th. Massing of colors and bands as may be desired.

10th. Instructions for the dismissal of the parade.

11th. Any other instructions or information necessary or desired.

Massed Column

(1) The impressiveness of a parade of Knights Templar can be greatly enhanced by massing all organizations in a solid phalanx, to march past the reviewing stand a second time. The exact formation will of course be determined by the width of the street, location of the reviewing stand or parade ground, etc., etc. It may be in column of platoons, companies or commanderies, without distance, and should fill the street from curb to curb. The column may be composed of one or more battalions, a Grand Commandery, or a Division in a larger parade, but when well formed the beauty and dignity of this manifestation of Christian loyalty and power, never fails to impress and inspire.

The description and illustrations here given can only be suggestive, since the final order of arrangement must always devolve upon the Commanding Officer, who will be governed by his resourcefulness and attendant circumstances. In general however, the following course will be found practicable.

(2) To make a return march-past, in massed column, with guide left.

After the parade has passed the reviewing stand and preferably beyond the vision of the reviewing officers, the following procedure is suggested: (See Plate No. 1.)

At the street intersection nearest the point where the head of the Massed Column will rest, the Grand Marshal and Staff will drop out and take post establishing the right

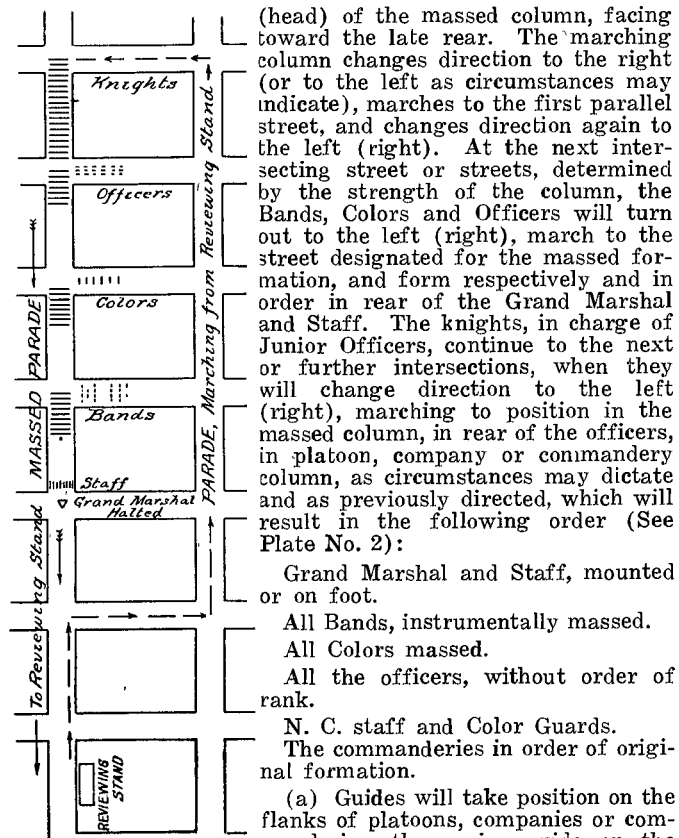

Par. 457-1

(b) Junior staff officers and color guards will form the first units in rear of the officers.

(c) The officers, without order of rank, and all other elements, will form in platoon, company, or commandery front, corresponding to the width of the massed column, at one pace distance.

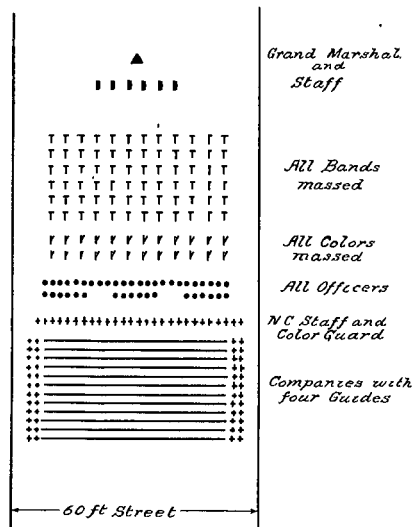

Par. 457-2

ing completed and closed up, the bugle will sound Attention, **FORWARD MARCH**. The column changes direction as other columns.

(g) If circumstances permit, the column may march to

(d) Should the street or avenue be of sufficient width the massed formation may be effected by counter march, without changing direction to a parallel street, although the best effect is secured when the column fills the street.

(e) The Grand Marshal and Staff will salute the Reviewing Officer; no other salutes or honors will be rendered by a massed column.

(f) If deemed necessary one or more "Adjutants" "free officers," may be designated to superintend the formation and march. The massed column be-

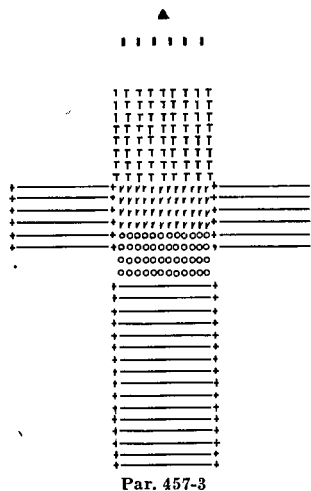

Par. 457-3

the rear of the reviewing stand, and pass in the same direction as before, with guide right. The objection to this method is the longer time required for the formation. Irregular blocks and diagonal streets afford good mask for the formation.

(h) On a parade ground or wide avenue, a Passion Cross, Patriarchal Cross, Cross of Salem or a Square, formed by similar means, may be found interesting and effective (See Plate No. 3).

(i) The illustrations here shown are diagrammatic, not drawn to scale. In view of the infrequency of such maneuvers it will generally be found desirable to furnish the officers with blue prints.

INSPECTIONS

COMMANDERY INSPECTION

458. The commandery being in line, at a carry, upon the approach of the Inspecting Officer, the Commander salutes, and the Inspector returns the salute.

The Inspecting Officer directs the Commander: **Prepare your Commandery for inspection.**

The Commander then commands: 1. **Open ranks**, 2. **MARCH**, 3. **FRONT**.

At the command **march**, ranks are opened as explained in Par. 191. The Commander, after being inspected, faces to the left and commands: **Prepare for Inspection**. He then

faces to the front, returns sword and accompanies the Inspector. The platoon leaders after being inspected face about and stand at ease.

NOTE—Officers being inspected, do not salute the Inspecting Officer, but stand at a carry.

Commencing on the right the Inspecting Officer makes a minute inspection of the sword, equipment and dress of each Knight. Each Knight as the inspector approaches executes the first motion of **Inspection Swords** (see plate Par. 88); as the inspector comes in front of him he executes the second and third motions, and so on in succession to the left of the line. Upon reaching the left of the front rank the Inspector passes along its rear to the right; then inspects the rear rank in the same manner.

The inspection being ended the Commander draws sword, salutes, closes ranks and takes his post.

BATTALION INSPECTION

459. The battalion being formed in column of commanderies at full distance, the Battalion Commander commands: 1. **Prepare for Inspection**, 2. **MARCH**.

At the second command, each Commander opens ranks, Par. 191. The staff officers form a line equal to the front of the column fifteen paces in front of the leading commandery. The non-commissioned staff (Sergeant Major, Quartermaster Sergeant, Commissary Sergeant and Bugler) form in a similar manner, three paces in rear of the staff, the Sergeant Major on the right.

The Adjutant conducts the Standard Guard to the head of the column and posts it three paces in rear of the center of the non-commissioned staff.

The drum major conducts the band to the rear of the column, passing around the right flank, and posts it facing to the front, twelve paces in rear of the rear commandery.

The Battalion Commander, seeing the movement executed, takes post three paces in front of the center of the staff and awaits the approach of the Inspecting Officer.

Such field and staff officers as may be superior in rank to the Inspecting Officer, do not take post in front of the column but accompany him.

The Inspecting Officer inspects the Battalion Commander, and accompanied by the latter inspects the staff officers. The Battalion Commander then commands: **REST**, returns sword, and with his staff, accompanies the Inspector. If the Battalion Commander be the inspector he commands, **REST**, returns sword, and inspects his staff, which then accompanies him. The Inspector, commencing at the head of the column, proceeds to make a minute inspection of the non-commissioned staff, Standard Guard, and the several commanderies in succession. The Adjutant gives the necessary commands for the inspection of the Standard Guard, non-commissioned staff and band.

As the Inspector successively approaches the commanderies, each Commander commands: 1. **Commandery**, 2. **ATTENTION**, 3. **Prepare for Inspection**.

Each is inspected, as prescribed for commandery inspection, Par. 458.

Having completed the inspection of the first commandery, the Inspector proceeds to the second, etc. The Commander of the first commandery closes ranks, and commands: **REST**, or, upon intimation from the Inspector, marches the commandery to its parade ground and dismisses it.

The band plays during the inspection of the commanderies and is brought to **open ranks** by the drum major on the approach of the Inspector, each man in succession, as the Inspector approaches him raises his instrument in front of his body, reverses it so as to show the opposite side, and then returns it to its former position.

PROPER DISPLAY OF THE AMERICAN FLAG

460. NOTE—The following code of flag etiquette, was adopted at a mass convention, the first annual meeting of which was held in Washington, D. C., June 14, 1923 (Flag day). There were representatives present from sixty-eight National Patriotic organizations including the American Legion, American Red Cross, and experts from the Army and Navy. A permanent organization of the conference was effected. The action is of course binding upon all the civil organizations represented, and while not having government sanction, is doubtless the most authoritative and well considered utterance ever given on the subject. The instructions are in accord with the fundamental rules of Heraldry. It should be remembered that the American Flag represents the living country and is itself considered a living thing. The union of the flag is the honor point, the right arm the sword arm, and therefore the point of danger and the place of honor.

Rules

1. The Flag should be displayed only from sunrise to sunset, or between such hours as may be designated by proper authority. It should be displayed on National and State holidays and on historic and special occasions. The Flag should always be hoisted briskly and lowered slowly and ceremoniously.

2. When carried in a procession with another flag or flags, the Flag of the United States should be either on the marching right, i. e., the Flag's own right, or when there is a line of other flags the Flag of the United States may be in front of the center of that line.

3. When displayed with another flag against a wall from crossed staffs, the Flag of the United States should be on the right, the Flag's own right, and its staff should be in front of the staff of the other flag.

4. When a number of flags are grouped and displayed

from staffs, the Flag of the United States should be in the center or at the highest point of the group.

5. When flags of States or cities or pennants of societies are flown on the same halyard with the Flag of the United States, the National Flag should always be at the peak. When flown from adjacent staffs the Flag of the United States should be hoisted first. No flag or pennant should be placed above or to the right of the Flag of the United States.

6. When flags of two or more nations are displayed they should be flown from separate staffs of the same height and the flags should be of approximately equal size. (International usage forbids the display of the flag of one nation above that of another in time of peace.)

7. When the Flag is displayed from a staff projecting horizontally or at an angle from the window sill, balcony, or front of building, the union of the Flag should go clear to the head of the staff unless the Flag is at half mast.

8. When the Flag of the United States is displayed in a manner other than by being flown from a staff it should be displayed flat, whether indoors or out. When displayed either horizontally or vertically against a wall, the union should be uppermost and to the Flag's own right, i. e., to the observer's left. When displayed in a window it should be displayed the same way, that is, with the union or blue field to the left of the observer in the street. When festoons, rosettes or drapings of blue, white and red are desired, bunting should be used, but never the Flag.

9. When displayed over the middle of the street, as between buildings, the Flag of the United States should be suspended vertically with the union to the north in an east-and-west street or to the east in a north-and-south street.

10. When used on a speaker's platform, the Flag should be displayed above and behind the speaker. It should never be used to cover the speaker's desk nor to drape over the front of the platform. If flown from a staff it should be on the speaker's front.

11. When used in unveiling a statue or monument, the

Flag should not be allowed to fall to the ground but should be carried aloft to wave out, forming a distinctive feature during the remainder of the ceremony.

12. When flown at half mast, the Flag is first hoisted to the peak and then lowered to the half staff position, but before lowering the Flag for the day, it is raised again to the peak. On Memorial Day, May 30, the Flag is displayed at half mast from sunrise until noon and at full staff from noon until sunset, for the Nation lives and the Flag is the symbol of the living Nation.

13. When used to cover a casket the Flag should be placed so that the union is at the head and over the left shoulder. The Flag should not be lowered into the grave nor allowed to touch the ground. The casket should be carried foot first.

14. When the Flag is displayed in church, it should be from a staff placed on the congregation's right as they face the clergyman. The service flag, the State flag, or other flags should be at the left of the congregation. If in the chancel, the Flag of the United States should be placed on the clergyman's right as he faces the congregation and the other flags on his left.

15. When the Flag is in such a condition that it is no longer a fitting emblem for display it should not be cast aside or used in any way that might be viewed as disrespectful to the National colors, but should be destroyed as a whole, privately, preferably by burning or by some other method in harmony with the reverence and respect we owe to the emblem representing our country.

Cautions

1. Do not permit disrespect to be shown to the Flag of the United States.
2. Do not dip the Flag of the United States to any person or any thing. The regimental color, State flag, organization or institutional flag will render this honor.
3. Do not display the Flag of the United States with the union down except as a signal of distress.

4. Do not place any other flag or pennant above or to the right of the Flag of the United States.

5. Do not let the Flag of the United States touch the ground or trail in the water.

6. Do not place any object or emblem of any kind on or above the Flag of the United States.

7. Do not use the Flag as drapery in any form whatever. Use bunting of blue, white and red.

8. Do not fasten the Flag in such manner as will permit it to be easily torn.

9. Do not drape the Flag over the hood, top, sides or back of a vehicle, or of a railroad train or boat. When the Flag is displayed on a motor car, the staff should be affixed firmly to the chassis or clamped to the radiator cap.

10. Do not display the Flag on a float in a parade except from a staff.

11. Do not use the Flag as a covering for a ceiling.

12. Do not use the Flag as a portion of a costume or of an athletic uniform. Do not embroider it upon cushions or handkerchiefs or imprint it on paper napkins or boxes.

13. Do not put lettering of any kind upon the Flag.

14. Do not use the Flag in any form of advertisement nor fasten an advertising sign to a pole from which the Flag of the United States is flying.

Proper Use of Bunting

Bunting of the National colors should be used for covering a speaker's desk, draping over the front of a platform and for decoration in general. Bunting should be arranged with the blue above, the white in the middle and the red below.

Salute to the Flag

During the ceremony of hoisting or lowering the Flag or when the Flag is passing to a parade or in a review all persons present should face the Flag, stand at attention and

salute. Sir Knights not in ranks should remove the headdress with the left hand and hold it at the right shoulder. Women should salute by placing the right hand over the heart. The salute to the Flag in the moving column is rendered at the moment the Flag passes.

When the National Anthem is played those present should remove the headdress and hold it as in the salute to the flag. Women should render the salute as to the Flag. When there is no Flag displayed, all should face toward the music.

BUGLE CALLS AND SIGNALS

461.

Attention.
Slow.



Forward.
Slow.



Halt.



Quick.
Double time.



First Call.

Quick.

Musical notation for 'First Call' in 3/8 time. It consists of two staves. The first staff has a treble clef and a key signature of one flat. It begins with a triplet of eighth notes (G4, A4, B4), followed by a quarter note (C5), a quarter note (B4), and a quarter note (A4). The second staff continues with a triplet of eighth notes (G4, A4, B4), followed by a quarter note (C5), a quarter note (B4), and a quarter note (A4) with a fermata.

Assembly.

Moderate.

Musical notation for 'Assembly' in common time (C). It consists of two staves. The first staff has a treble clef and a key signature of one flat. It begins with a quarter note (G4), followed by a quarter note (A4), a quarter note (B4), and a quarter note (C5). The second staff continues with a quarter note (B4), a quarter note (A4), a quarter note (G4), and a quarter note (F4) with a fermata.

Adjutant's Call.

Quick.

Musical notation for 'Adjutant's Call' in 2/4 time. It consists of two staves. The first staff has a treble clef and a key signature of one flat. It begins with a quarter note (G4), followed by a quarter note (A4), a quarter note (B4), and a quarter note (C5). The second staff continues with a quarter note (B4), a quarter note (A4), a quarter note (G4), and a quarter note (F4).

Flourish for Review.

Quick.

Musical notation for 'Flourish for Review' in 2/4 time. It consists of one staff with a treble clef and a key signature of one flat. It begins with a quarter note (G4), followed by a quarter note (A4), a quarter note (B4), and a quarter note (C5).

Reveille.

Quick.

Musical notation for 'Reveille' in 2/4 time. It consists of three staves. The first staff has a treble clef and a key signature of one flat. It begins with a quarter note (G4), followed by a quarter note (A4), a quarter note (B4), and a quarter note (C5). The second staff continues with a quarter note (B4), a quarter note (A4), a quarter note (G4), and a quarter note (F4). The third staff continues with a quarter note (E4), a quarter note (D4), a quarter note (C4), and a quarter note (B3) with a fermata.

Ena.

D. C.

Retreat.

Moderate.

Musical notation for 'Retreat' in 2/4 time. It consists of three staves. The first staff has a treble clef and a key signature of one flat. It begins with a quarter note (G4), followed by a quarter note (A4), a quarter note (B4), and a quarter note (C5). The second staff continues with a quarter note (B4), a quarter note (A4), a quarter note (G4), and a quarter note (F4). The third staff continues with a quarter note (E4), a quarter note (D4), a quarter note (C4), and a quarter note (B3) with a fermata.

Musical score for 'The Bugle' on page 246. It consists of three systems, each with three staves. The notation includes various rhythmic patterns, rests, and dynamic markings such as mf and f .

Extinguish Lights. (Taps.)

Slow.

First system of musical notation for 'Extinguish Lights. (Taps.)' section, marked *Slow.* It consists of two staves with notes and rests.

Mess.

Quick.

Second system of musical notation for 'Extinguish Lights. (Taps.)' section, marked *Quick.* It consists of three staves, including a 2/4 time signature and triplets.

Fire.

Quick.

Third system of musical notation for 'Extinguish Lights. (Taps.)' section, marked *Quick.* It consists of three staves with notes and rests.

Repeat at will

RECALL

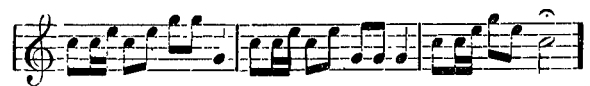
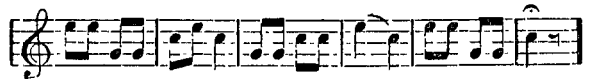
Moderato.*Officer's Call.**Quick.**Church.**Slow.**School.**Quick.**To the Color.**Quick time**Quickstep.**Quick time.*

A musical score for 'The Bugle' on page 250. It consists of six staves of music in a single system. The music is written in a single melodic line on a treble clef staff. The first five staves contain the main melody, and the sixth staff appears to be a continuation or a different part of the piece. The notation includes various rhythmic values such as eighth and sixteenth notes, and rests.

Quickstep.

A musical score for 'Quickstep' on page 250. It consists of three staves of music in a single system. The music is written in a single melodic line on a treble clef staff. The first staff begins with a 2/4 time signature. The notation includes various rhythmic values such as eighth and sixteenth notes, and rests.

President's March.

Quick time.

A musical score for 'President's March' on page 251. It consists of six staves of music in a single system. The music is written in a single melodic line on a treble clef staff. The first staff begins with a 'Quick time.' tempo marking. The notation includes various rhythmic values such as eighth and sixteenth notes, and rests. There are also some decorative flourishes and accents in the notation.

General's March.

Quick time.

A musical score for 'General's March' on page 251. It consists of four staves of music in a single system. The music is written in a single melodic line on a treble clef staff. The first staff begins with a 'Quick time.' tempo marking. The notation includes various rhythmic values such as eighth and sixteenth notes, and rests. There are also some decorative flourishes and accents in the notation.

ALPHABETICAL INDEX

	Par.
A	
About Face	52
Adjutant, The	2
Alarms, With Sword	136
Alignments, to Form	74
American Flag, see National Flag	153-460
Arch of Steel, Who Entitled to	126-165
Arm Signals	44
As You Were	19
Asylum Ceremonies, Application to	Page 3
At Ease	49
Attention	50
B	
Back Step	66
Backward Dress	75
Band, The, in Public Parade	157
Position of, in Escort	158
With the Battalion	351
With the Regiment	409
Battalion, see School of the Battalion	332 to 407
Battalions, Organization of, Recommended	170
Beauceant, The, Position, Salute	153
Breadth of a Knight	187
Break into Subdivisions, see Note	215
Brigade, The	435
Bugle Signals and Calls	Pages 243 to 251
Bugle Signals, When Used	42
C	
Cadence	56
Center Forward in Sections	288
Ceremonies, Purpose of	3-436 to 459
Change Direction	22-78-200
Change Front	302
Change Step	70
Charge Swords	128
Chief of Section on the Left	189
Chief of Staff	2
Church Parade	159
Close Ranks	192
Close in Mass-Subdivisions	283
Color Commandery, in Battalion	355
Colors, The, Composition of	153
Color, How to Hang	155-460
Color, Proper Display of	460

Formation for Public Parade	147
Formations in Mass	280-395-457
Forward March	76
Front	51
Front of a Knight, see Definitions	
Front into Line, from Threes	207-208
Full Distance	23
Full Distance in Column	239
G	
General Principles	1 to 10
General Rules Always Govern	10a
Grand Commander, When in Command	340
Grand Commandery, Formations of, for Ceremonies	170
Grand Commander, Others, Honors to	168
Grand Master, Honors to	168
Grand Officers, Disposition and Posts of	341-342
Grand Officers Reception, Cross Swords	126-165
Grand Standard, Not a Parade Banner	153
Grand Standard, on Church Parade, see Note	159
Greek Cross, to Form	308
Guide, The, Always on the Right, Unless	20
Announcement Follows Command	20
Battalion, Successive Formations	354-375
Changing Direction, Conforms to the Column	22
Close in Mass, Position of	400
Corporals, Guides of Threes	10
Distances of	187
Guides, How Designated	10
Guides of Threes (Corporals) May Give Commands	188
Interior, Plank, Platoon Guides	180-184-186-187-188-252-253
In Column of Threes or Sections	20
In Successive Formations, Precede	20-376
Marking the Line	375
May Call the Cadence in Marching "1-2-3-4" or "Left," "Right"	214
Platoons, Column of	253
Position of, in General	186-188
Position Taking Intervals	188
Right Guide as First Sergeant	189
Right, Left or Center, When	20
H	
Half Distance in Column	238
Half Step	63
Halt, To	67
Hand Salute	54
Honors and Salutes	160
Honors and Salutes, when in carriages	164
Honors to Grand Master, and Others	168
Hooked Up, The Sword, see Note	83

I

Incline to the Right, Left.....	22
Index, The.....	Pages 252-264
In-Place Halt.....	18
Inspection of Battalion.....	459
Insignia of Rank, Military.....	138a
Inspection of Commandery.....	458
Instruction to Officers.....	137 to 146
Instruction Without Swords.....	47
Interior Guides.....	180
Intervals Between Commanderies.....	355-372
Intervals, Take.....	86-87
Introduction.....	Page 7
Reasons for Drill Regulations.....	Page 7
Follow U. S. I. D. R., Why.....	Page 7
Authorities Consulted.....	Page 8
Display Drill and Ceremonies.....	Page 8
Invert Column, Threes or Sections.....	306

J

Judging and Scoring, Plan for.....	176
Judges of Competitive Drills.....	173
Junior Officers.....	6
Junior Officers Commanding, Position of.....	33
Junior Staff Officers, Position of.....	33
Junior Warden, Left Guide.....	189

K

Kneel, Sir Knights.....	132
Knights Never Salute in Ranks, Except by Command.....	166

L

Leader, Company.....	184
Leading Subdivision May Be Halted Sooner.....	206
Line of Columns, Sections, Platoons, etc.....	25-394-408
Line of Masses.....	408

M

Manual of the Color.....	154
Manual of the Sword.....	83
March by the Flank.....	68-372
March in Line—by the Flank.....	76-77
Marching Honors at Carry Swords.....	161
March to the Rear.....	69
Markers, Posted, When, How.....	375
Mark Time.....	62
Mass by Subdivisions, Movements of.....	280-406
Massed Column and Crosses.....	457
Military Insignia of Rank.....	138a
Military Titles for Drill Officers.....	9-175

Column Right, Left, Incline.....	22
Command, Definition of.....	38
Command, Manner of Giving, When.....	40-58
Command of Execution, Who Gives.....	39-58
Commands, Oral, Limitation of.....	39-455
Commands, Who Repeat.....	35
Commander, The Eminent, Duties of.....	1-2-178
May Precede the Band.....	157
May Ride in a Carriage.....	157
May Salute Sitting.....	163-164
Official Title of.....	6
Position, in Commandery Drill.....	181
Responsible for Instruction of Officers.....	178
Simulated Rank of.....	6
Staff, Formation of.....	156
Staff and, Swords How Carried.....	156
Commandery, See School of the Commandery.....	178-274
Commandery and Company Synonymous.....	332
Commandery Display Movements.....	287
Break from Right to March to Left.....	300
Change Front to Right, Left, Rear.....	302-304
Cross, Egyptian.....	323
Cross, Greek.....	308
Cross, Passion.....	312-314
Cross Patriarchal.....	316
Cross, Saint Andrew.....	321
Cross, Salem.....	319
Double Column of Threes to Rear.....	293
Form Column Faced to Rear.....	305
Form Line Faced to Rear.....	290
Form Line on Standard.....	291
Invert Column, Threes or Sections.....	306
March from Center in Sections.....	288
Right of Platoons Rear into Column.....	299
Square, to Form.....	325
Threes in Circle Right (Left) About.....	297
Triangle, to Form.....	323
Wheel on the Center.....	292
Companies, When to Form.....	189
Competitive Drills.....	171
Conformity with U. S. I. D. R.....	4
Continue the Manual.....	136a
Corporals, Guides of Threes.....	10
Count Threes, Ones, Twos, Fours.....	189
Crosses, see Commandery Display.....	302-319
Cross Swords.....	121
Cuts, Sword.....	121

D

Definitions.....	Pages 9-12
Deploy Column.....	281
Deposit Chapeaux.....	133

Description Controls Illustrations.....	10a
Discipline, Necessity of.....	3-137
Dismiss the Commandery.....	190
Display Movements, see Commandery Display.....	287
Distance Between Ranks, Guides.....	187
Distance in Mass.....	399
Double Column of Threes to Rear.....	350
Double Rank, see Note.....	11
Double Time.....	15-16-17-57-60-115-144
Drill Corps and Competitions.....	170 to 177
Drills, Purpose of.....	3
Drill System, Whence Derived.....	c
Drill Without Swords.....	46

E

Echelon, Order in.....	248-251-432
Egyptian Cross.....	323
Elective Officers, Past, Rank of.....	156
Emblematic Figures-Drill.....	287
Eminent Commander, see Commander.....	2-156
Escort of the Color.....	169
Escorts of Honor.....	158
Evolutions of the Battalion.....	348
Evolutions of the Regiment.....	408
Executive Officer.....	2
Eyes Right, Left.....	51-438

F

Facings, in Marching.....	52
Fall In.....	73
Fall Out.....	49
Field Music, with Band.....	404
Field Officers.....	342-344-345
File Closers, Change Flank.....	188
File Closers, Execute Manual, When.....	188
Files, Column of.....	215
Files in Echelon.....	348
Fixed Pivot.....	21
Flag, The, see National Flag.....	153-161
Flank, by Right, Left, March.....	77
Flank, March by the.....	197
Flank Movements.....	13
Form Arch of Steel.....	126
Form Lines for Rehearsal.....	116-117-118
Form Line from Threes or Sections.....	204
Form Line on Standard Guard.....	291
Form Line by Two Movements.....	231
Form the Commandery, To.....	189
Formation of the Battalion.....	353 to 359
Formation of the Commandery.....	189
Formation of the Regiment.....	411

Review, Regimental.....	452:
Salute of Beauceant, State Color.....	441
Salute of Officers, Staff.....	438
Turns Out After Saluting, Who.....	439
When Inspector Is Junior in Rank.....	448
Rests, Fall Out, Rest, At Ease.....	49
Right Dress, Left, Backward.....	75
Right, Left, Step.....	65
Ritual, Extract From.....	163
Roll Call.....	189
Rules for Competitive Drills.....	174-175
Route Column, Habitual Formation.....	213
Route Step.....	72

S

Salem, Cross of.....	319
St. Andrew, Cross of.....	321
Salutes, by Whom, When, How.....	166-167
Salutes, Extract From Ritual.....	163
Salutes, Knights to Be at Carry Swords.....	161
Salute to Grand Master and Others.....	160
Honors and Salutes, when in carriages.....	164
Schedule Plan for Competition.....	171
School of the Knight and Squad.....	45 to 133
The Knight, Purpose of the School.....	45
Individual Drill, When, How.....	46-47
Position of the Knight, Attention.....	48
Rests, The, Attention.....	49-50
Eyes Right (Left) Front.....	51
Facings.....	52-53
Setting Up Exercises.....	Note 72
Salute With the Hand.....	54
Stand at Ease.....	49
Steps and Marchings, Length, Cadence.....	55-56-57
Commands of Execution, When Given.....	58
Quick Time.....	59
Double Time.....	60
Mark Time.....	62
Half Step.....	63
Side Step.....	65
Back Step.....	66
Halt.....	67
March by the Flank—to the Rear.....	68-69
Change Step.....	70
Oblique March.....	71
Route Step.....	72
Smoking in Ranks—On Parade.....	164
Squad, The.....	73 to 82
Fall In.....	78
Alignments.....	74
Dress, Right, Left, Backward, Front.....	75
March in Line.....	76

March by the Flank	77
Change Direction	78
Oblique March	79
Wheelings	80-81-82
Sword, Manual of the	83 to 136
How to Hold the Sword	83
Hooked-Up, Sword, see Note	83
Names of Parts, Sword	84
Draw Swords, Position of Carry	85
Carry Sword, All Movements Start From	85
Intervals, Take Sword	86-87
Present Swords	88
Salute Swords	90
Order Swords	92
Support Swords	94
Port Swords	96
Rest Swords	98
Shoulder Swords	100
Reverse, Left-Reverse Swords	102-104
Parade Rest	106
Inspection Swords	108
Invert Swords	109
Guide Swords	111
Return Swords	112
Secure Swords	113
Swords to Carry Upon Halting	113
Double Time, Position of Sword	115
Sword Manual, Ritual	116 to 136
Form Lines for Reception-Rehearsal	116-118
On Guard	119
Parries or Cuts, The	121-123
Wield Swords	124
Form Arch of Steel	126
Rest on Swords	127
Charge Swords	128
Cross Swords	121
Un-Cover, Re-Cover	130-131
Kneel, Sir Knights	132
Chapeaux, Deposit	133
Alarms, With Sword	136
Silent Manual	136a
School of the Officer	137 to 146
Importance and Responsibility of	137
Discipline and Courtesy Essential	137
Difference Only in Rank, Not in Class	138
Systematic Training Necessary	139
Commands Given With Sword Drawn	140
Manual, May Omit Part	141
In Formation but Never in Ranks	142
Salute, How, When	143
Double Time, Position of the Sword	144
Reading Orders, Position of Sword	145

Mounted Drill	9
Moving Pivot	21
Movements by Platoons	252
Movements from a Halt, Marching	14
Movements in Mass	406
Movements Only Executed One Way	10a
Movements Toward Either Flank	12

N

National Anthem, Played, How, When	160
National Anthem, Salute to	160-161
National Flag, Never Salutes	153-161
National Flag, Proper Display of	460

O

Oblique in Column	199
Oblique March	71-79-199
Obstacle, to Pass	211-370
Officer, at Double Time, Position of	144
Battalion Rank and Position of	333 to 336-350
Dressing the Line, Position of	181
Exchange Salutes at Close of Conversation	163
Harmony with Military Titles and Rank	5 to 9
In "Formation" but Never in "Ranks"	142
Instructions to	137 to 146
Junior Officers, see Definitions	Page 11
Mounted, About Face	30
Mounted, Salute of	29
Mounted, Who, When	28
Position of Being Inspected	459
Posts, as Instructors, on Ceremonies	27-146
Posts of, Where, When Taken	26
Preliminary Study Enjoined	1
Rank and Duties of	2-5-6-7-8
Repeat What Commands	35
Salute of, When Reporting	32
School of (Important to Study)	137-146
Simulated Rank of	6-7-8
Staff, How Formed	28
Sword Manual, Executes What Part	140
Sword Salute of Junior Officers	91
Temporary Appointment of	5-10
When Giving Commands, Position Sword	40-41
Who Gives the Word of Command	39
Official Knight Templar Honors	168
On Guard	119
On Right (Left) Into Line	205
Open Files, Front, Flank	220 to 226
Open Order from Column of Threes	227
Open Ranks, To	191

Oral Commands, Limitation of.....	39-455
Orders, Commands, Signals.....	34
Orders, Definition of.....	37
Orderlies, Position of.....	28
Order in Echelon.....	248-251-432

P

Parade of Battalion.....	454
Parade of Commandery.....	453
Parade of Regiment.....	455-456
Parade Rest.....	49
Parade, Street.....	457
Parries.....	121
Passion Cross.....	312-314
Past Commanders, Rank, Position of.....	156
Patriarchal Cross.....	316
Platoon.....	178 to 186-252-296
Composition of.....	178-184
Close Column of.....	278
Flank Files, Guides of.....	184
Guides of, May be Excused.....	180
Guides Pass to Opposite Flank.....	186
Leaders, Position of.....	178-182-184-253
Leaders, Repeat What Commands.....	184
Movements by Platoons.....	252
Numbered, How.....	178
Ploy Into Column.....	276
Right (Left) of, to Rear.....	296
Preparatory Commands, How Given.....	12-39
Prizes for Competitive Drills, Rule 14.....	175
Program, The, Plan.....	172-177
Proper Display of the American Flag.....	460
Public Parade of Commandery, Formation for.....	147
Publishing Orders, Position of Sword.....	145

Q

Quick Time.....	59
-----------------	----

R

Regiment, see School of the Regiment.....	339-418
Regiments, Permanent, Recommended.....	170
Reviews, General Rules.....	436-451
Applicable Under All Conditions.....	436
Band, Plays, Turns, Out, etc.....	442
Commands, Who Gives, How.....	444-445
Double Time When Necessary.....	446
Guide Toward Reviewing Officer.....	443
March in Quick Time Only.....	443
Officers, Rank, Position of.....	436-437
Review, Battalion.....	451
Review, Commandery.....	450

Movements in Mass.....	406
Change Front on First Commandery.....	407
Parade of Battalion.....	454
Review of Battalion.....	451
Inspection of Battalion.....	459
School of the Regiment.....	339 to 432
General Rules.....	339 to 410
Composition of.....	339
Officers, Assignment, Position of.....	339 to 341, 343, 409
Field Officers.....	342
Commands, Who Gives, Repeats, How.....	344-410
Mounted, Who Should Be.....	345
Battalions, Rank and Position of.....	346
Interval Between Battalions.....	347
Band, Post of.....	409
Field Music, Post of.....	409
Base Battalion, Designation of.....	410
Evolutions of the Regiment.....	408 to 434
Lines of Columns, Descriptions of.....	408
Formation of the Regiment.....	411
Successive Formations.....	413
Dismiss, Marchings, Alignments, etc.....	412
Front into Line, from Column Battalions.....	414
Mass, Movements in.....	415 to 431
Echelon, Order in.....	432
Parade of Regiment.....	455
Review of Regiment.....	452
School of the Brigade.....	435
Street Parade.....	457
Scoring, Plan of.....	176
Score Cards, Model for.....	176
Sections, Movements by.....	234 to 247
Sections, Position, Number of.....	189
Sections a Preferred Formation.....	179
Senior Warden, Right Guide (1st Sergt.).....	189
Side Step.....	65
Signals, Bugle, Whistle, Arm.....	42-43-44
Silent Manual.....	136a
Single Rank.....	11-24-47-189
Square, to Form.....	325
Square, to Change Direction.....	327
Staff, Who Appoints.....	8-10
Staff, Rank, Formation, Movements of.....	28-31-33
Standard Guard, Composition of, see Note.....	183
Battalion, Evolutions With.....	349
Beauceant Always Salutes.....	153
Composition of the "Colors".....	158
Formation for Public Parade.....	148
Grand Standard Not a Parade Banner.....	153
Manual of the Color.....	154
May Be Grouped—the Colors.....	152
National Flag, Never Salutes.....	153

Not Used in Commandery Drill.....	151
Position in the Line.....	149
Position in Mass.....	400
Regiment, Formation With.....	411
State Color, When to Salute.....	153
Standard, The Grand, at Church Parade, see Note.....	159
Star Spangled Banner, Salute to.....	160
Steps and Marchings.....	55-56-57
Street Parade.....	457
Successive Formations, Rules.....	375
Sword Exercises, Ritual.....	116
Sword Manual.....	83
Sword, the Parts Named.....	84

T

Table of Contents.....	Pages 5-6
Tables of Organization, U. S. A.....	8
Templar Display Drill.....	287
Templar Rank, Nature of.....	133
Threes, Movements of.....	197-198
Threes, the Unit of Formation.....	11
The Standard Guard.....	153-183
To the Color.....	160
To the Rear March.....	69
Training, Necessity, Method of.....	139
Triangle, The.....	323
Turn on Fixed Pivot.....	195
Turn of Moving Pivot.....	196
Twos, Column of.....	217

U

Un-cover, Re-cover.....	130-131
Un-cover and Salute Never Together.....	166
Unit of Threes.....	11

W

Wheeling Distance.....	23
Wheel, Fixed and Moving Pivots.....	21
Wheelings.....	80
Wheel in Circle.....	81-203-233-286
Wheel in Circle, Subdivisions.....	286
Wheel the Commandery.....	193
Wheel on Center.....	292
Whistle Signals, When Given.....	43
Wield Swords.....	124
Wings, of a Command.....	348

Position and Post of, on Drill-Ceremonies.....	146
School of the Commandery and Platoon.....	178 to 274
The Platoon, General Rules.....	178 to 182
Interior Guides, Not Always Present.....	180
Instructor, Position of.....	181
Platoon Chiefs, Position of.....	182-184
Guides, Position of.....	180-184-186-187-188
Standard Guard, Composition of, see Note.....	183
Standard Guard, Not in Drill.....	183
How Constituted, Platoon.....	184
Distance Between Ranks, Guides.....	187
File Closers Change.....	188
The Commandery.....	189-286
Form the Commandery.....	189
Dismiss the Commandery.....	190
Open Ranks.....	191
Close Ranks.....	192
Wheel the Commandery.....	193
Change Direction.....	194-200
Turn on Fixed (Moving) Pivot.....	195-196
Form Column to the Right (Left).....	197
Form Column to the Front.....	198
Oblique in Column.....	199
March to the Rear.....	202
Form Line from Column of Threes.....	204
On Right (Left) Into Line.....	205
Form Line to the Front.....	207
March to the Rear.....	209-210
Pass Obstacle.....	211
Route Column.....	213
Form Column of Files, from Threes.....	215
Form Column of Twos.....	217
Open Files, Close.....	220 to 230
Form Line by Two Movements.....	231
Wheel in Circles, Threes.....	233
Movements by Sections.....	234 to 247
Order in Echelon.....	248 to 251
Movements by Platoons.....	252 to 274
Form Column to the Right (left).....	253
Change Direction.....	258
Guides.....	180
March the Column to the Rear.....	262
Form Line from Column.....	263
Form Line on Right (Left).....	265
Break into Platoons.....	266
March Column by the Flank.....	268
Advance by the Right (Left).....	270
Form Column of Threes.....	272
Form Column of Platoons.....	273
Ploy into Column of Platoons.....	276
Close Column of Platoons.....	278
Deploy on Rear Subdivision.....	281

Deploy on Interior Subdivision.....	282
Close Subdivisions in Mass.....	283
Double Column of Files in Open Order.....	285
Wheel Subdivisions in Circle.....	286
Parade of Commandery.....	453
Review of Commandery.....	450
Inspection of Commandery.....	458
School of the Battalion and Regiment.....	332 to 434
Battalion, General Rules.....	332 to 338
Composition of.....	332
Commandery and Company Synonymous.....	352
Provisional Battalions, Organization of.....	352
Officers, Rank and Position of.....	333-336-350
Company Designations.....	335
Equalization Advised.....	337
Rank and Position of.....	338
Evolutions of the Battalion.....	348 to 407
Commanderies, Companies, Designated.....	348
Wings, Right and Left.....	348
Standard Guard, The.....	349
Officers and Staff, Posts of.....	350
Band, The.....	351-357
Commands, Who Gives, How.....	352
Formation of the Battalion.....	353 to 359
Guides on the Line.....	354
Color Commandery.....	355
Dressing on the Line.....	356
Open Ranks.....	360
Close Rank.....	361
Rest the Battalion.....	362
Dismiss, Commanderies-Companies.....	363
March in Line.....	364
March to the Rear.....	365
Rectify the Alignment.....	368
Pass Obstacle.....	370
March by the Flank.....	372
Break from the Right (Left) to March to the Left (Right).....	373
Form Line from Threes.....	374
Successive Formations, Rules.....	375
On Right (Left) into Line.....	376
Form Front into Line, from Threes.....	377
Form Line by Two Movements.....	379
Form Double Column of Threes.....	380
Form Column of Commanderies.....	383
Break Rear into Column, from Flank.....	385
Break from Right (Left).....	386
Change Direction.....	387
Form Line to Right (Left).....	389
On Right (Left) into Line.....	391
Front into Line, from Column Commanderies.....	392
Line of Columns.....	394
Formations in Mass.....	399