

LC/MS APPLICATIONS IN DRUG DEVELOPMENT

Wiley-Interscience Series on Mass Spectrometry

Series Editors

Dominic M. Desiderio

*Departments of Neurology and Biochemistry
University of Tennessee Health Science Center*

Nico M. M. Nibbering

University of Amsterdam

The aim of the series is to provide books written by experts in the various disciplines of mass spectrometry, including but not limited to basic and fundamental research, instrument and methodological developments, and applied research.

Books in the Series

Michael Kinter, *Protein Sequencing and Identification Using Tandem Mass Spectrometry* 0-471-32249-0

Mike S. Lee, *LC/MS Applications in Drug Development* 0-471-40520-5

Forthcoming Books in the Series

Chhabil Dass, *Principles and Practice of Biological Mass Spectrometry*
0-471-33053-1

LC/MS APPLICATIONS IN DRUG DEVELOPMENT

Mike S. Lee

 WILEY-
INTERSCIENCE

A JOHN WILEY & SONS, INC., PUBLICATION

This book is printed on acid-free paper. ☹

Copyright © 2002 by John Wiley & Sons, Inc., New York. All rights reserved.

Published simultaneously in Canada.

No part of this publication may be reproduced, stored in a retrieval system or transmitted in any form or by any means, electronic, mechanical, photocopying, recording, scanning, or otherwise, except as permitted under Sections 107 or 108 of the 1976 United States Copyright Act, without either the prior written permission of the Publisher, or authorization through payment of the appropriate per-copy fee to the Copyright Clearance Center, 222 Rosewood Drive, Danvers, MA 01923, (978) 750-8400, fax (978) 750-4744. Requests to the Publisher for permission should be addressed to the Permissions Department, John Wiley & Sons, Inc., 605 Third Avenue, New York, NY 10158-0012, (212) 850-6011, fax (212) 850-6008, E-Mail: PERMREQ@WILEY.COM.

For ordering and customer service information please call 1-800-CALL-WILEY.

Library of Congress Cataloging-in-Publication Data:

Library of Congress Cataloging-in-Publication Data is available. 0-471-40520-5

Printed in the United States of America.

10 9 8 7 6 5 4 3 2 1

CONTENTS

| | |
|--|-----------|
| Preface | ix |
| Acknowledgments | xi |
| 1. Introduction | 1 |
| Emerging Analytical Needs / 1 | |
| Integration of LC/MS into Drug Development / 3 | |
| Partnerships and Acceptance / 6 | |
| Overview / 10 | |
| 2. Drug Development Overview | 11 |
| Analysis Perspectives / 11 | |
| The Four Stages of Drug Development / 12 | |
| Drug Discovery / 14 | |
| Preclinical Development / 15 | |
| Clinical Development / 16 | |
| Manufacturing / 17 | |
| 3. Accelerated Drug Development | 19 |
| Accelerated Development Strategies / 20 | |
| Quantitative and Qualitative Process Elements / 20 | |

| | |
|---|-----------|
| Quantitative Process Pipeline / 24 | |
| Qualitative Process Pipeline / 25 | |
| Motivating Factors / 27 | |
| Analysis Opportunities for Accelerated Development / 28 | |
| Full-Time Equivalent / 28 | |
| Sample Throughput Model / 29 | |
| Elimination Model / 29 | |
| Rate-Determining Event Model / 31 | |
| Accelerated Development Perspectives / 33 | |
| 4. LC/MS Development | 34 |
| The Elements of LC/MS Application / 34 | |
| HPLC / 35 | |
| Mass Spectrometry / 35 | |
| LC/MS Interface / 36 | |
| LC/MS Growth / 38 | |
| 5. Strategies | 41 |
| Standard Methods / 43 | |
| Template Structure Identification / 46 | |
| Databases / 49 | |
| Screening / 50 | |
| Integration / 53 | |
| Miniaturization / 55 | |
| Parallel Processing / 56 | |
| Visualization / 58 | |
| Automation / 61 | |
| Summary / 63 | |
| 6. LC/MS Applications | 65 |
| Drug Discovery / 65 | |
| Proteomics / 68 | |
| Protein Expression Profiling / 70 | |
| Quantitation / 76 | |

| |
|--|
| Glycoprotein Mapping / 78 |
| Natural Products Dereplication / 83 |
| Lead Identification Screening / 88 |
| Bioaffinity Screening / 89 |
| Combinatorial Library Screening / 92 |
| Open-Access LC/MS / 96 |
| Structure Confirmation / 97 |
| High Throughput / 100 |
| Purification / 102 |
| Combinatorial Mixture Screening / 103 |
| In Vivo Drug Screening / 106 |
| Pharmacokinetics / 109 |
| In Vitro Drug Screening / 115 |
| Metabolic Stability Screening / 118 |
| Membrane Permeability / 119 |
| Drug-Drug Interaction / 121 |
| Metabolite Identification / 122 |
| Preclinical Development / 123 |
| Metabolite Identification / 125 |
| Impurity Identification / 132 |
| Degradant Identification / 140 |
| Clinical Development / 145 |
| Quantitative Bioanalysis—Selected Ion Monitoring / 148 |
| Quantitative Bioanalysis—Selected Reaction Monitoring / 152 |
| Quantitative Bioanalysis—Automated Solid-Phase Extraction / 156 |
| Quantitative Bioanalysis—Automated On-Line Extraction / 162 |
| Metabolite Identification / 165 |
| Degradant Identification / 168 |
| Manufacturing / 171 |
| Impurity Identification Using Data-Dependent Analysis / 173 |

Peptide Mapping in Quality Control / 176
Patent Protection / 178

| | |
|--|------------|
| 7. Future Applications and Prospects | 183 |
| Workstations / 183 | |
| Multidimensional Analysis / 186 | |
| Miniaturization / 187 | |
| Information Management / 189 | |
| Strategic Outsourcing / 190 | |
| Summary / 191 | |
| 8. Perspectives on the Future Growth of LC/MS | 192 |
| 9. Conclusions | 195 |
| Glossary | 197 |
| References | 205 |
| Index | 235 |

PREFACE

The combination of high-performance liquid chromatography and mass spectrometry (LC/MS) has had a significant impact on drug development over the past decade. Continual improvements in LC/MS interface technologies combined with powerful features for structure analysis, qualitative and quantitative, has resulted in a widened scope of application. These improvements coincided with breakthroughs in combinatorial chemistry, molecular biology, and an overall industry trend of accelerated drug development. The integration of new technologies in the pharmaceutical industry created a situation where the rate of sample generation far exceeds the rate of sample analysis. As a result, new paradigms for the analysis of drugs and related substances have been developed. Both pharmaceutical and instrument manufacturing industries have mutually benefited.

The growth in LC/MS applications has been extensive, with retention time and molecular weight emerging as essential analytical features from drug target to product. LC/MS-based methodologies that involve automation, predictive or surrogate models, and open-access systems have become a permanent fixture in the drug development landscape. An iterative cycle of “what is it?” and “how much is there?” continues to fuel the tremendous growth of LC/MS in the pharmaceutical industry. During this time, LC/MS has become widely accepted as an integral part of the drug development process.

It is clear that significant developments are happening in the analytical sciences and that future innovations will continue to positively impact the ability for industry scientists to create, share, and collaborate.

This book, based on an earlier review (Lee and Kerns, 1999), describes the utility of LC/MS techniques for accelerated drug development and provides perspective on the significant changes in strategies for pharmaceutical analysis. Specific examples of LC/MS innovation and application highlight the interrelation between the drug development activities that generate samples and the activities responsible for analysis. It should be noted that the extent of LC/MS applications within drug development is hardly complete, and therefore, this book is not intended to be encyclopedic. The goal was to provide an industry perspective on how and why LC/MS became a premier tool for pharmaceutical analysis. Frequently, the review of a specific methodology or technology creates a barrier of interaction with other disciplines. The applications described in this book are organized with regard to current drug development cycles (i.e., drug discovery, preclinical development, clinical development, manufacturing) to provide an enabling reference for a wide community of chemists and biologists. Future applications of LC/MS technologies for accelerated drug development and emerging industry trends that deal with sample preparation, chromatography, mass spectrometry, and information management are also discussed.

Mike S. Lee

ACKNOWLEDGMENTS

The inspiration, direction, and focus for this book were derived mainly through my pharmaceutical industry experiences. These experiences were fueled by the belief that analytical sciences play an integral and proactive role in the pharmaceutical industry. I am thankful that my first-hand experiences were, for the most part, pleasant. I do, however, acknowledge that the discovery, development, and manufacture of pharmaceuticals are extremely challenging endeavors. I believe that there is considerable reward for such a challenge. Obviously, there is a tangible reward that can be benchmarked by a cure for disease and/or commercial success of a drug. There is also a less-tangible reward that manifests itself in the form of accomplishment and enlightenment accrued over a period of time. I feel fortunate to have experienced many of the rewards that go with drug development. I am grateful that I was able to share these experiences with a diverse group of professionals. To have had the opportunity to participate in these activities is indeed noble. To have the opportunity to recount perspective on these activities is humbling. Interestingly, and perhaps predictably, I found that the reward is more fondly remembered in a nostalgic sense; recounting the experiences in real-time can be intense. The effort put forward for this project seemed to follow a similar path as input and suggestions from many individuals were required. Invaluable feedback and support was generously given by numerous people that included: Bradley

Ackermann, Tim Alavosus, Brad Barrett, Andries Bruins, Ben Chien, John Coutant, Dominic Desiderio, Ashok Dongre, Todd Gillespie, Edward Kerns, Steven Klohr, Zamas Lam, Ken Matuszak, Sara Michelmores, John Peltier, Kumar Ramu, Ira Rosenberg, Robyn Rourick, Charlie Schmidt, Marshall Siegel, Gary Valaskovic, Kevin Volk, David Wagner, Scott Wilkin, Antony Williams, Nathan Yates, and Richard Yost.

At many times during this project I found myself asking the question, “Why am I doing this?” In my attempt to answer, I would always seem to recount my positive experiences with the analytical sciences. Thus, I feel compelled to give thanks to those who were integral to my education in the analytical sciences and inspirations to my professional development. First, I thank the University of Maryland for encouraging me to pursue an education in the sciences. Second, I thank the graduate program at the University of Florida for providing me an opportunity to focus in the analytical sciences and teaching me how to formulate question and thought. Third, I thank Bristol-Myers Squibb for balancing my hunger for the application of analytical sciences with the need to experience collaboration, interaction, and growth. To each of the above mentioned institutions, I am grateful for the support and continued source of inspiration. To all the people at the above mentioned institutions, I will hold dear the friendships, relationships, and memories that are the result of success and failure. And finally, I wish to thank my loving wife and family for their continual encouragement and support for everything I do. For this, I am truly blessed.

CHAPTER 1

INTRODUCTION

Current trends in drug development emphasize high-volume approaches to accelerate lead candidate generation and evaluation. Drug discovery-based technologies that involve proteomics, biomolecular screening, and combinatorial chemistry paved the way, resulting in shortened timelines and the generation of more information for more drug candidates. The impact on the overall drug development cycle has been significant, creating unprecedented opportunities for growth and focus, particularly in the analytical sciences.

EMERGING ANALYTICAL NEEDS

Perhaps a major cause of these opportunities is the fact that the rate of sample generation far exceeded the rate of sample analysis. To put this factor in perspective, consider the following example that deals with combinatorial chemistry. Prior to the advent of combinatorial chemistry technologies, a single bench chemist was capable of synthesizing approximately 50 final compounds per year, depending on the synthesis. Today, chemists are capable of generating well over 2000 compounds per year, using a variety of automated synthesis technologies. If traditional approaches to analytical support were maintained, then analysts would outnumber chemists by nearly 40 to 1!

The reality of the situation has become evident: Without analytical tools that could keep pace with new benchmarks for sample generation, the advantages would not be fully realized. Thus, the relationship between sample generation and analysis is a major issue in the pharmaceutical industry. Clearly, traditional approaches for analysis are not capable of meeting specialized needs created by dramatic improvements in sample generation.

New technologies figure prominently in the success of drug development and directly impact pharmaceutical analysis activities. The integration of sample generation technologies such as combinatorial chemistry workstations, for example, created distinctly new requisites for analysis. Rapid, high throughput, sensitive, and selective methods are now a requisite for pharmaceutical analysis. Also, the ability to analyze trace mixtures, using an instrumental configuration compatible with screening approaches, emerged as an important feature.

As requirements for analysis rapidly adapted to breakthroughs in sample generation, a new scientific and business culture aimed at decreasing costs and accelerating development became entrenched in the pharmaceutical industry. These factors combined to produce more frequent, and perhaps, new demands on analysis. In particular, these demands underscored the importance of analytical instrumentation and the creation of novel analysis strategies. For example, to keep pace with emerging needs, the timely evaluation of new tools and applications appropriate for pharmaceutical analysis is essential. Once evaluated, the effective integration of these analysis tools represents an equally significant hurdle. The development of novel strategies for analysis has been an effective approach for introducing new technologies and for creating opportunities for streamlined drug development.

These trends have been complemented by the need to determine or predict molecular and physicochemical properties of an unprecedented number of structurally diverse molecules faster than previously required and at earlier stages in the drug development cycle. Prospective methods for investigating pharmaceutical properties were born, along with data-mining techniques to search large databases. Furthermore, new experimental approaches typically generated samples that contain small quantities of analyte in complex mixtures. This combination placed a tremendous burden on existing methods for pharmaceutical analysis.

Many industry initiatives feature the integration of sample-

generating and analysis activities, resulting in new paradigms for the discovery, evaluation, and development of pharmaceuticals. The basic idea of these initiatives is to do more with less. Invariably, *more* resources tend to be awarded to activities involved with sample generation, whereas *less* is received for analysis. As a result, a wide variety of analysis-based applications have been implemented. These applications emphasize *efficiency* and *throughput*. Three common themes arose from these activities:

- 1 An earlier availability of information leads to faster decision making.
- 2 Integration of instrumentation with information networks is a popular approach for combining high throughput analytical information generation with drug candidate screening.
- 3 Software is a powerful resource for the coordination of analysis events and the management and visualization of data.

A considerable growth in analysis methods resulted, with the primary focus being on accelerating drug development. New tools and strategies for analysis combined with technologies such as biomolecular screening, combinatorial chemistry, and genomics have positioned the pharmaceutical industry to *harvest* discovery and *manufacture* development opportunities.

INTEGRATION OF LC/MS INTO DRUG DEVELOPMENT

Liquid chromatography/mass spectrometry (LC/MS)-based techniques provide unique capabilities for pharmaceutical analysis. LC/MS methods are applicable to a wide range of compounds of pharmaceutical interest, and they feature powerful analytical figures of merit (sensitivity, selectivity, speed of analysis, and cost-effectiveness). These analytical features have continually improved, resulting in easier-to-use and more reliable instruments. These developments coincided with the pharmaceutical industry's focus on describing the collective properties of novel compounds in a rapid, precise, and quantitative way. As a result, the predominant pharmaceutical sample type shifted from nontrace/pure samples to trace mixtures (i.e., protein digests, natural products, automated synthesis, bile, plasma, urine). The results of these developments have been sig-

nificant, as LC/MS has become the preferred analytical method for trace mixture analysis (Figure 1.1).

An important perspective on these events, improvements in LC/MS technology and industry change, is just how LC/MS techniques became so widely accepted within every stage of drug development. It can be argued that the proliferation of LC/MS occurred not by choice but by need. For example, if a nuclear magnetic resonance (NMR)-based approach existed for the quick, sensitive, and efficient analysis of combinatorially derived mixtures in the early 1990s, then LC/MS would certainly have had a limited role in this area of drug development. However, at the time LC/MS provided the best performance without any rival or complement.

The significance of this fact is twofold. First LC/MS has, indeed, become the method of choice for many pharmaceutical analyses. Because the utilization of analysis technology in the pharmaceutical industry is highly dependent on perception, the breakthroughs and barriers that LC/MS has overcome provided opportunity for acceptance and a widened scope of application. Currently, LC/MS is widely perceived in the pharmaceutical industry to be a viable choice, as opposed to a necessary alternative, for analysis. Second, these events led to an increased understanding of LC/MS in such a way that practitioners and collaborators have become more diverse. The result of this diversity is a mutually shared sense of purpose

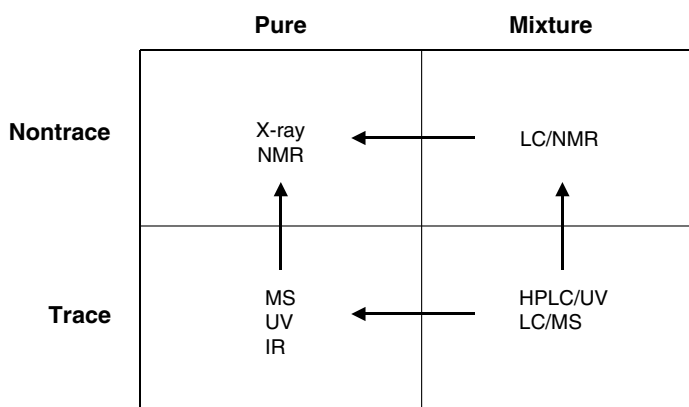

Figure 1.1 Structure analysis matrix that illustrates pharmaceutical analysis preferences for four specific sample types: nontrace/pure; nontrace/mixture; trace/pure; and trace/mixture. (Courtesy of Milestone Development Services, Newtown, Pa., USA.)

within the industry, inspiring creativity and generating new perspectives on analysis.

Along with timing and perception issues, four technical elements have been critical for the acceptance of LC/MS-based techniques in the pharmaceutical industry. The first is *separation sciences*. Simply put, the chromatographic method defines the pharmaceutical analysis. Chromatography provides analytical criteria to compare, refine, develop, and control the critical aspects of developing and manufacturing high-quality drug products. Thus, it is common in industry to see LC/MS methods distinguished by the chromatographic technology and features rather than by mass spectrometry performance and capabilities. Indeed, the effective combination of a wide variety of high performance liquid chromatography (HPLC) technologies and formats with mass spectrometry played a vital role in the acceptance of LC/MS. This achievement is significant because HPLC-based methods are a universally recognized analysis "currency," and perhaps, the first to be used throughout every stage of drug development.

The second element that allows for industry acceptance of LC/MS techniques is *mass spectrometry*. The analytical figures of merit dealing with sensitivity and selectivity provide a powerful platform for analysis. However, it was not until these analytical attributes could be harnessed into a reliable, reproducible, rugged, and high throughput instrument that mass spectrometry techniques could be taken seriously as an integral tool for drug development. Though perhaps indirect, the pioneering work performed with LC/MS interfaces that featured moving belt (Smith and Johnson, 1981; Hayes et al., 1983; Games et al., 1984), direct liquid introduction (DLI) (Yinon and Hwang, 1985; Lee and Henion, 1985; Lant et al., 1985), thermospray ionization (TSI) (Blakely and Vestal, 1983; Irabarne et al., 1983), and electrospray ionization (ESI) (Whitehouse et al., 1985; Bruins et al., 1987; Fenn et al., 1989) approaches certainly played a significant role in the acceptance of mass spectrometry as a routine tool for pharmaceutical analysis. Furthermore, added dimensions of mass analysis provide enhanced limits of detection for the analysis of complex mixtures and unique capabilities for structure identification.

The third element is *information*. The rate of analysis and subsequent distribution of results has grown tremendously due to the increased use of LC/MS and other information-rich technologies. From strictly an analysis perspective, LC/MS has demonstrated a

unique capability for maintaining high quality performance and a rapid turnaround of samples. Yet, it is the accurate and efficient processing of information that has been essential for LC/MS use and acceptance. As a result, LC/MS has developed unique partnerships with tools responsible for sample tracking, interpretation, and data storage. Consequently, LC/MS has become an information-rich, information-dependent technology in the pharmaceutical industry. LC/MS is highly dependent on software to integrate key analysis elements that deal with sample preparation, real-time analysis decisions, and the distribution of results. The pharmaceutical industry has benefited from this trend and, as a result, the derived information has been easily translated into a form that many professionals can understand, interpret, and base their decisions on.

Finally, the fourth element is a *widened scope of application*. The fact that LC/MS is now routinely used during every stage of drug development is a powerful benchmark for acceptance. The increased performance of applications that incorporate LC/MS have, in turn, stimulated new performance levels for sample preparation, high speed separations, automated analysis, information databases, and software tools, to name a few. Motivated by unmet industry needs, the drive for new applications has stimulated tremendous growth in pharmaceutical analysis marked by invention and creativity.

PARTNERSHIPS AND ACCEPTANCE

What has happened in the pharmaceutical industry during this relatively short time span is truly remarkable. With the advent of advanced technologies responsible for increasing the rate of sample generation, there is strong motivation to respond with LC/MS-based analysis techniques. The understanding of principles, fundamentals, operation, and maintenance enabled researchers to improve analytical performance. The power of “seeing is believing” led to lower barriers of acceptance as well as to a new breed of practitioners.

Chemists, biologists, and other industry professionals are becoming more familiar and comfortable with LC/MS and its corresponding data as an everyday tool for analysis. The vast technical advances with LC/MS, along with a renewed emphasis on sharing, collaboration, and mutual understanding among disciplines, have helped researchers increase efficiency and overall productivity. At the same time, highly trained, highly skilled analysts are continually chal-

lenged with learning new principles in chemistry, molecular biology, and pharmaceutical development.

Of course, all of the previously mentioned successes would not have been possible without basic research and the ultimate design and manufacture of analytical instrumentation. Basic research and the manufacture of high performance instruments have each played a significant role in the drug development process. Continued relationship and partnership with universities and instrument manufacturers help to increase awareness and better understanding, and to bridge the gaps among research, discovery, and the development of high-quality pharmaceutical products.

The seven ages of an analytical method first described by Laitinen (1973) can be used to depict the important partnerships among academia, instrument manufacturers, and the pharmaceutical industry. These partnerships are responsible for the widened scope of application and acceptance of LC/MS in the pharmaceutical industry today. The *ages* of an analytical method are translated into *stages* of LC/MS events that lead to its routine use in the pharmaceutical industry (Table 1.1). The various stages represent a continuum for LC/MS advancement, beginning with basic research performed in universities, followed by the design and manufacture of instruments, and concluding with industry benchmarks for acceptance.

The first and second stages involve the *conception* of the fundamental principles and experimental *validation* of the analytical potential, respectively. The basic research conducted in universities during the 1970s and 1980s marked the conception stage of LC/MS methods. For example, the fundamentals of interfacing an HPLC with a mass spectrometer were studied (Arpino et al., 1974; Carroll et al., 1975; Arpino, 1982) and mechanisms of ionization were characterized (Thomson and Iribarne, 1979; Blakely et al., 1980; Whitehouse et al., 1985). The validation stage of the analytical method represents the convergence of interest among research, instrumentation, and potential application. The results and interest generated from the basic research that dealt with LC/MS led to significant investments in technology from instrument manufacturers. Applications dealing with pharmacokinetic (Covey et al., 1986) and biomolecular (Wong et al., 1988) analysis showed significant promise, insight, and direction. The market potential of an LC/MS instrument, providing expanded capabilities over gas chromatography/mass spectrometry (GC/MS) and HPLC methods for pharmaceutical analysis, was realized. The *availability* of commercial instruments

TABLE 1.1 The seven stages of the LC/MS analytical method that result from partnership within academia, instrument manufacturers, and industry

| Stage | Event | Activity |
|--------------|---|--|
| Conception | Fundamental principles outlined | Basic research. |
| Validation | Analytical potential experimentally validated | Basic research; applied research; technology investments; product development; targeted pharmaceutical applications. |
| Availability | Instruments developed/manufactured | Commercial instruments sold; method development; applied research. |
| Foundation | A platform of performance established | Method development/refinement; analysis benchmarks; quantitative bioanalysis methods established; new product development. |
| Application | A widened scope of application | Unique methods developed to address sample generating technologies and traditional analyses for the identification of biomolecules, metabolites, and natural products. |
| Acceptance | Used as a routine, standard method | Development of fully automated methods for high throughput analysis; open access instruments; standard methods; outsourcing. |
| Senescence | Replaced by newer methods | Decline in applications, utility, and popularity? |

Source: Courtesy of Milestone Development Services, Newtown, Pa., U.S.A.

provided the pharmaceutical industry with LC/MS capabilities plus training, service, and technical support. Applied research directed toward meeting current industry needs ensued, with active participation and collaboration from university- manufacturing- and pharmaceutical-led research groups (Covey et al., 1991; Weintraub et al., 1991; Aebersold et al., 1992; Weidolf and Covey, 1992). The ability to reliably develop and refine LC/MS-based methods helped to establish a solid fundamental *foundation* of this technique. The utility of LC/MS methods for quantitative bioanalysis was benchmarked as the industry standard in the early 1990s for performance and efficiency (Fouda et al., 1991; Wang-Iverson et al., 1992). New products were designed and developed exclusively for LC/MS performance. A widened scope of *application* occurred with the development of unique LC/MS-based methods for the analysis of novel pharmaceuticals. Analysis methods were easily developed and refined in the pursuit of opportunities created by the use of traditional, time-consuming procedures. Applications that deal with biomolecule analysis, drug metabolism and pharmacokinetics, natural products research, and combinatorial chemistry represent some important areas of LC/MS diversification and are discussed in the following chapters of this book. Perhaps the most significant benchmarks for industry *acceptance* of LC/MS appeared when fully automated methods were developed for high throughput analysis and when collaborators (i.e., sample generators) themselves became analysts via the purchase of instruments or routine use of open-access instruments (Taylor et al., 1995; Pullen et al., 1995). These methods and approaches were developed primarily in response to sample-generating technologies. And this step represents the present stage of LC/MS methods in the pharmaceutical industry.

Although the scope of application continues to grow, the routine use of LC/MS technologies are now embraced by pharmaceutical researchers. Standard methods that incorporate highly specialized features are routinely developed for a variety of novel applications. Furthermore, many LC/MS applications that deal with quantitative bioanalysis (i.e., pharmacokinetics studies) are frequently outsourced to contract analytical laboratories. Thus, the routine use of LC/MS is a benchmarked commodity for drug development.

The final stage, *senescence*, does not appear to be a prospect in the near future, but a decline in popularity and application will likely occur sometime. Perhaps the onset of this stage will be triggered by the divergence of academic, instrument manufacture, and industry

interests. However, the current industry trends highlight the tremendous challenge of drug development and an expanding need for tools that provide for fast, sensitive, and selective analysis of drugs and drug-related compounds.

OVERVIEW

This book focuses on LC/MS applications in drug development. It examines the role of LC/MS in the pharmaceutical industry during the past decade and illustrates key elements for success that include significant advances in instrumentation, methodology, and application. The applications are highlighted with reference to the analysis opportunity and analysis strategy is implemented. Examples that depict unique advantages of LC/MS during specific stages of drug development are selected to capture the significant events and/or initiatives that occurred in the pharmaceutical industry during this time. In many instances, an analysis is provided to illustrate the result or development situation if LC/MS was not used. In these cases, the impact (number of samples) and value (cost) on drug development is highlighted independent of the technical features of LC/MS analysis. These unique industry perspectives offer an enabling “currency” and assist in understanding the events that resulted in the proliferation of LC/MS throughout the drug development cycle.

The book concludes with perspectives on future trends and some thoughts on the future direction of LC/MS applications in the pharmaceutical industry. New standards of analytical performance are discussed with regard to throughput and capacity. A prospective look at how higher standards of analytical performance in the pharmaceutical industry will effect relationships with academia and instrument manufacturers is featured. These sections extend the initial thesis of accelerated development to include new analysis bottlenecks and perspectives on analysis issues and industry needs.

CHAPTER 2

DRUG DEVELOPMENT OVERVIEW

Drug development may be defined as the series of specialized events performed to satisfy internal (i.e., competitive industry benchmarks) and external (i.e., regulatory compliance) criteria, to yield a novel drug. Much attention has been given to the various activities of drug development. These accounts primarily have a sample-generating perspective. For example, the timely review of innovations in automated synthesis stimulated new paradigms for drug discovery (Gallop et al., 1994; Gordon et al., 1994; Desai et al., 1994). The combined vision and depth of knowledge has had a profound affect on the pharmaceutical industry, helping to promote a greater understanding of technology and to develop new strategies for discovering novel lead candidates.

ANALYSIS PERSPECTIVES

The role of analytical technologies traditionally has been to *respond* to a pharmaceutical event, rather than to *lead* one. A complementary perspective from an analytical point of view can provide substantial insight into relevant drug development issues. This insight may not be intuitively obvious from a sample-generating (i.e., chemistry, biology) approach. And, when sample analysis activities are taken into consideration as an equal partner with sample-generating

activities, global, and perhaps, integrated strategies for drug development may be derived.

This view suggests that analysis insights provide unique perspectives and opportunities to contribute to the design, development, and manufacture of high-quality drug products. This statement does not intend to imply that this process does not occur in the pharmaceutical industry, only that there is opportunity for more such interaction and collaboration. With that said, sample analysis can be viewed as a dependent partner with sample generation. Without analysis, sample generation yields no information for satisfying drug development criteria, and vice versa. Therefore, no matter how quickly or efficiently samples are generated, the benefits are not realized unless they are analyzed in an equally efficient manner. Identical, or perhaps, matched criteria for performance (i.e., speed, throughput, compatibility) is, therefore, required for sample-generating and sample-analysis responsibilities.

THE FOUR STAGES OF DRUG DEVELOPMENT

Drug development has become more complex and highly competitive while the sample analysis contributions have become increasingly important. This perspective recognizes the impact of sample analysis activities and the corresponding information that must be accumulated throughout the various stages of development.

At present, drug development consists of four distinct stages: (1) drug discovery; (2) preclinical development; (3) clinical development; and (4) manufacturing (Table 2.1). Each development stage is geared toward the swift accomplishment of goals and objectives. Each stage culminates with a specific corresponding milestone: lead candidate; investigational new drug (IND)/clinical trial application (CTA); new drug application (NDA)/marketing authorization application (MAA); and sales. The IND and NDA are the required regulatory documents filed in the United States; the CTA and MAA are required in Europe.

For the successful completion of each milestone, a diverse array of analyses is required. The focus is generally unique to the specific stage of development and is a determining factor for criteria for analysis. For example, drug discovery approaches typically require rapid, high-throughput screening methods with the purpose of selecting a lead candidate from a large number of diverse compounds. Analyses that emphasize quick turnaround of results are

TABLE 2.1 The four stages of drug development and their corresponding milestone and analysis emphasis

| Development stage | Milestone | Analysis Emphasis | LC/MS Analysis Activities |
|-------------------------|----------------|-------------------|---|
| Drug discovery | Lead candidate | Screening | Protein identification; natural products identification; metabolic stability profiles; molecular weight determination for combinatorial/ medicinal chemistry support. |
| Preclinical development | IND/CTA filing | Evaluation | Impurity, degradant, and metabolite identification. |
| Clinical development | NDA/MAA filing | Registration | Quantitative bioanalysis; structure identification. |
| Manufacturing | Sales | Compliance | Impurity and degradant identification. |

desirable. As the discovery lead candidate moves forward through the drug development cycle, the analysis requirements become more focused. In preclinical development, the main goal is directed toward the swift filing of the IND/CTA. Preclinical development analyses are aimed at providing more specific and detailed information for the evaluation of drug properties. This stage of drug development is also the first point at which regulatory issues are addressed; therefore, the use of validated analytical methods and the compliance with Food and Drug Administration (FDA) guidelines are critical. For example, pharmaceutical scientists interact with regulatory agencies to establish impurity limits so development and approval phases can proceed in a predictable fashion. Thus, the generation and analysis of drug products are conducted in accordance with FDA good manufacturing practice (GMP) and good laboratory practice (GLP) regulations, respectively. During the clinical development stage, the lead candidate (now an IND or CTA) is fully characterized in humans. Subsequent analyses continue to be performed under strict protocol and regulatory compliance to register the drug for NDA/MAA.

Once the NDA/MAA is approved, analyses are focused on specifications to provide regulatory compliance and to ensure quality during the manufacturing stage.

Following is a brief summary of the four stages of drug development. Significant events are highlighted with respect to their relationship to analysis requirements.

Drug Discovery

The goal of the drug discovery stage is to generate a novel lead candidate with suitable pharmaceutical properties (i.e., efficacy, bioavailability, toxicity) for preclinical evaluation. The drug discovery process is often initiated with a decision to begin research on a new biological target. Studies are performed to characterize and define the target to establish the biological rationale. High-throughput screening assays are developed in conjunction with a formal medicinal chemistry program. Potential lead compounds contained in natural product sources or from the extensive database of a synthetic compound library are screened for activity. Lead compounds identified from screening efforts are optimized in close collaboration with exploratory metabolism programs and drug safety evaluations.

In 1997, it was estimated that the synthesis and screening of approximately 100,000 compounds are typically required for the discovery a single quality lead compound (Baxter, 1997). Identifying a lead compound can take up to 2–4 years. Optimization of the resulting lead may take an additional 1–2 years. The drug discovery stage culminates with a decision to advance a lead candidate for preclinical development studies and more extensive evaluation. Thus, the drug discovery stage involves three primary analysis activities: target identification, lead identification, and lead optimization.

A survey forecasted the impact of new technologies on drug discovery and preclinical development activities (Banerjee and Rosofsky, 1997). Figure 2.1 illustrates the maximum and minimum development times in 1996 and projections for the year 2000. The results suggest that lead identification activities would decrease from an average of 15 months in 1996 to just over 6 months in 2000. The focus of these ambitious goals was to cut discovery timelines in half, triple the discovery output of lead candidates, and accelerate the identification of drug therapies with blockbuster potential. Generally, a shorter and more predictable timescale is projected

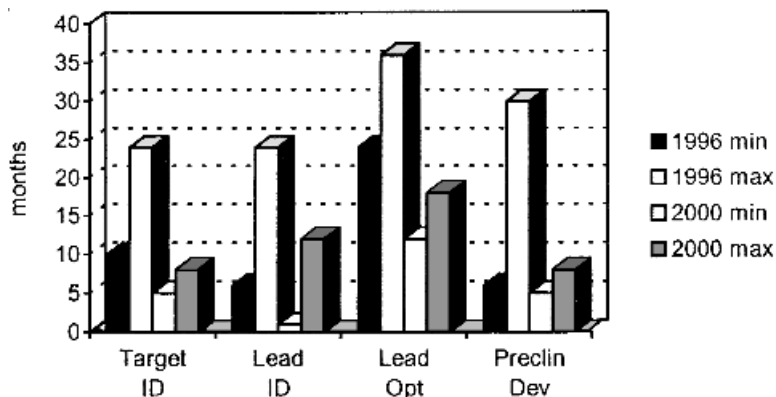

Figure 2.1 The maximum and minimum development times for a drug in 1996 and projections for the year 2000. (Reprinted with permission from Banerjee and Rosofsky, 1997. Copyright 1997 Andersen Consulting.)

for drug discovery-related activities. A recent follow up study (www.accenture.com) found that the pharmaceutical and biotechnology industries fell short of their goals. To meet current 10 year growth projections, the industry must now increase the number of lead candidates by 50 percent. In addition to these revised predictions, the costs associated with research and development continued to rise. Approximately 70 million, equivalent to 250 full-time equivalent (FTE) employees, is required for each lead candidate that reaches the development stage.

Preclinical Development

The preclinical stage of drug development focuses on activities necessary for filing an IND/CTA. The completed IND/CTA contains information that details the drug's composition and the synthetic processes used for its production. The IND/CTA also contains animal toxicity data, protocols for early phase clinical trials, and an outline of specific details and plans for evaluation. Process research, formulation, metabolism, and toxicity are the major areas of responsibility in this development stage. Analysis activities that feature LC/MS primarily focus on the identification of impurities, degradants, and metabolites.

Generally, preclinical development activities are completed in 10–15 months; however, shorter timelines are predicted (Banerjee

and Rosofsky, 1997). Preliminary data from early animal toxicology and pharmacokinetic studies are obtained to determine the optimal doses and dosage form for initial phase I clinical trials (see the next section, “Clinical Development”). These early studies also provide insight into the extent of safety monitoring necessary during phase I. These data support the IND/CTA submissions and clinical development for all indications. All issues that are expected to attract the attention of regulatory agencies are identified at this time and are addressed in the clinical plan.

During preclinical development, the structure, physical and chemical characteristics, and stereochemical identity of the IND/CTA candidate are fully characterized. This information, for example, is required for the chemical manufacture and control (CMC) section of the IND. Appropriate bioanalytical methods are developed for the evaluation of pharmacokinetics, typically a series of studies focusing on absorption, distribution, metabolism, and excretion (ADME) in toxicology species, as well as systemic exposure and metabolism in toxicological and clinical studies.

Characterization of the new drug substance is initiated, which includes preliminary information on stability, preparation, and control for manufacturing purposes. Preliminary information about the composition, manufacture and packaging, and control of the investigational drug product is obtained. Registration dossiers require a full description of the manufacture and control of the new drug substance. Stability of the new drug substance and drug products for at least 6 months is required. Appropriate data confirming the stereochemical homogeneity of the drug substance during stability studies, validation of analytical methods, and manufacture of the drug products are also required.

Clinical Development

The clinical development stage comprises three distinct components or phases (I, II, and III), and culminates in the filing of the NDA/MAA. Each phase involves process scale-up, pharmacokinetics, drug delivery, and drug safety activities. During phase I clinical development, the compound's safety and pharmacokinetic profile is defined. The determination of maximum concentration at steady state (C_{\max}), area under the plasma concentration time curve (AUC), elimination half-life, volume of distribution, clearance and excretion, and potential for drug accumulation is made in addition to studies that provide estimates of efficacious doses. Dose levels typically

range from 10mg to 2000mg, with half the patients on placebo. Patients are carefully observed, monitored, and questioned about side effects. Plasma samples are obtained at appropriate time points following administration of the drug, from which plasma-time concentration curves are determined. Urine is collected just prior to drug administration and at subsequent time points to provide an estimate of the rate of urinary excretion of drug and/or metabolites. Urine is also collected during the study to provide insights into metabolic stability. Typical pharmacodynamic evaluations include blood glucose monitoring and blood pressure. Safety evaluations include physical examinations and clinical laboratory tests (i.e., liver function tests) performed before dosing and before discharge. Phase I studies typically involve fewer than 100 patients.

After acceptable safety and pharmacokinetic data are observed in phase I trials, phase II studies are initiated with the goal of establishing efficacy, determining the effective dose range, and obtaining safety and tolerability data. In phase II, the dose and dosing interval to be employed in the patient population and the estimated no-effect dose are defined. Phase II studies may require 1–1.5 years to complete and may involve several hundred patients.

The goal of phase III is to complete human safety and efficacy programs and to secure approval. Programs are designed to demonstrate clinical efficacy superior to a placebo. Placebo-controlled, double-blind, randomized trials that last up to 6 months are typically performed on several hundred to several thousand patients. Additional studies with comparative agents may be performed to satisfy registration requirements and to help to determine marketing and pricing strategies.

Manufacturing

As with earlier stages of drug development, the transition to the manufacturing stage begins while the previous clinical development activities are moving toward their milestone (NDA/MAA). Plans begin well in advance to ensure manufacturing capability for the production of large quantities of synthesized drug substance and drug product. Once formulated, the drug is packaged and readied for distribution to pharmacies. Manufacturing processes and facilities undergo a preapproval regulatory review and periodic inspections once production is in progress. Analytical procedures and information databases are formalized into standard operating procedures (SOPs) and product specifications. This information and technology

are formally transferred by quality control (QC) scientists in manufacturing groups for routine monitoring and release.

Several other events occur simultaneously with these activities. Some events focus on extending therapeutic applications and formulations. Clinical studies are conducted to extend the diseases (indications) for which the drug is proven efficacious and safe. For example, TAXOL[®] was initially approved for the treatment of ovarian cancer, and was later extended for the treatment of breast cancer after follow-on clinical studies demonstrated efficacy for the new indication. In addition, new product formulations are investigated to extend the routes of administration for patient convenience, increased bioavailability, and new disease therapies. For example, a drug initially developed as an injectable product may be formulated as a tablet for oral administration.

Some manufacturing events are triggered by business considerations. Changes in processes, such as the synthetic production of a drug previously isolated from natural sources, can ensure the expanded supply and a more economical production. During the manufacturing stage, comparisons are made to other drug products in the same category, including stability, bioavailability, and purity. With the direct advertising of pharmaceuticals and more widespread information on drugs, patients are taking a more active role in therapy decision making. Thus, comparative information is of interest during the transition from exclusive patent-protected drugs to the open generic market. Also, companies monitor for the infringement of process patents by other organizations.

Other events that occur during the manufacturing stage produce an immediate need for analytical troubleshooting. Long-term stability studies (LTSS) may reveal new degradants in retained lots, such as particulates in an injectable. Adverse patient events are reported and investigated, and consumer complaints about off-taste or odor are immediately addressed. Manufacturing interruptions occur due to contamination by packaging materials or unexpected impurities that exceed product specifications. Also, with the growing use of outsourced services for the product manufacturing of intermediates, drug substance, and drug product, out-of-specification results must be immediately addressed.

CHAPTER 3

ACCELERATED DRUG DEVELOPMENT

An accelerated drug development strategy focuses on producing drug candidates and accomplishing goals in less time than with traditional development approaches. The key elements of accelerated development strategies involve the early identification of the most promising drug candidates. Opportunity exists to expose weaknesses early in the drug development cycle and to make decisions on how to address (i.e., refine) or drop from further development. The premise of this approach focuses on maximizing return on investment via the cost-effective application of resources. The return on investment is captured by bringing a profitable drug to market faster and by utilizing resources more efficiently.

Technology transfer (i.e., methods, data, results) is critical to the success of accelerated development paradigms. The ability to transfer information efficiently within a specific department has been the traditional industry approach for advancing understanding of a potential lead candidate as well as providing further definition of a drug candidate. This north-south movement of data is typically supported by a variety of complementary analytical techniques. The transfer of data and information in an east-west motif has been a central strategy for accelerated drug development. An east-west movement of data and information involves collaboration and coordination of events among a variety of departments throughout the drug development cycle. LC/MS-based techniques have been a

widely applicable platform for technology transfer mainly because of the preponderance of trace mixture sample types and the easily understood data format (i.e., retention time, molecular weight) in each phase of drug development.

ACCELERATED DEVELOPMENT STRATEGIES

Two accelerated development strategies involving analysis have emerged from large-scale sample-generating efforts (Table 3.1). The first involves *quantitative process* approaches aimed at achieving high throughput analysis. The focus is on sample volume with the primary objective of accommodating increases in sample generation. This approach is typically accomplished with the addition of more resources and/or improved methods for analysis, and is highly effective when a go decision is made for lead candidate development. The activities associated with faster analysis are generally independent of sample-generating approaches. Incorporating an automated task into an existing method for analysis is an example of a quantitative process approach.

The second strategy involves the use of *qualitative process* approaches that are supposed to eliminate candidates that have unsuitable characteristics from the drug development pipeline. Analyses that focus on pharmaceutical properties are performed during the earlier stages of drug development. This approach usually requires the development of a new application that is highly integrated with sample-generating responsibilities that lead to faster decisions to stop-development activities. Predictive in vivo and in vitro models for metabolic stability are examples of a qualitative process approach.

Accelerated development exploits the relationship between quantitative and qualitative process approaches. Often, the balance between the two approaches creates new opportunities for development success as well as significant challenges for analysis. Typically, one approach is developed in response to the other, followed by refinement and integration.

QUANTITATIVE AND QUALITATIVE PROCESS ELEMENTS

To help illustrate the dynamics of quantitative and qualitative process approaches to accelerated drug development, Figure 3.1

TABLE 3.1 The characteristics of quantitative and qualitative process approaches for accelerated drug development featuring analysis

| Accelerated Development Strategy | Objective | Focus | Analysis Features |
|----------------------------------|--------------------------------|---------------------------|---|
| Quantitative process approach | High throughput analysis | Sample volume | Provide increased support when a go decision is made for development. Increased resources and/or improved methods of analysis. Independent of sample generation. Intralaboratory integration (i.e., automation). |
| Qualitative process approach | Elimination of weak candidates | Pharmaceutical properties | Generate information to stop development. Development of a new application and implemented during early stages of development. Integrated with sample generation. Interlaboratory integration (i.e., predictive models). |

Source: Courtesy of Milestone Development Services, Newtown, Pa., U.S.A.

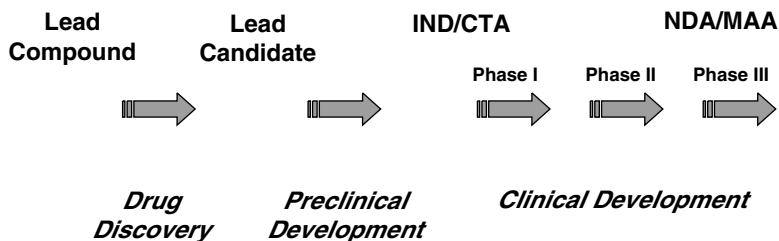

Figure 3.1 Hypothetical drug development pipeline, illustrating activities during a 12-month period. Three stages of drug development are indicated at the bottom of the figure. The corresponding milestones for each stage are indicated at the top of the figure. (Courtesy of Milestone Development Services, Newtown, Pa., USA.)

shows a hypothetical pipeline that represents a snapshot of drug development activities during a 12-month period. The focus is on the drug discovery, preclinical, and clinical development stages. Quantitative process elements are defined as the actual number of compounds (i.e., lead compounds, lead candidates, investigational new drugs/clinical trial applications [IND/CTAs], new drug applications/marketing authorization applications [NDA/MAAs]) in each development stage. Qualitative process elements are defined as the development activity (i.e., metabolism, pharmacokinetics, toxicity) used to evaluate and select compounds for advancement to the next stage.

Quantitative process approaches are typically benchmarked by *productivity*, derived from the *number* of compounds (or samples) in each development stage, whereas qualitative approaches are benchmarked by *efficiency*, corresponding to the *rate* at which drug candidates (or samples) flow through the various stages in the pipeline. The relationship of these accelerated development elements provides a useful tool to highlight the features of quantitative and qualitative process approaches, and these elements are important factors in identifying strategic analysis opportunities for increased productivity and efficiency.

The application of these approaches to accelerated drug development has become more essential due to aggressive sample-generating technologies such as combinatorial chemistry. The ability to reach higher levels of performance (i.e., high throughput) without sacrificing the quality of data (i.e., accuracy) is desirable. These

approaches typically involve the refinement of an existing activity or the creation of an entirely new one.

Refinement approaches lead to a decreased cycle time via the faster and more efficient analysis of samples. Automation is an obvious and desirable goal to speed up the analysis, optimize the measurement, and coordinate diverse tasks. A tremendous emphasis is placed on aspects of analysis such as sample preparation and data processing and data management. Once considered to be peripheral to the actual analysis, these activities have become important elements of high throughput analysis.

The creation of new analysis approaches is a strategic complement to refinement. The object is not necessarily focused on replacing an existing method, but rather supporting it by providing an opportunity to screen and/or predict the likelihood of success. This approach is effective for generating useful information while simultaneously providing a measure of relative order or ranking. Although qualitative process approaches to accelerated development actually add a step to the drug development cycle, they provide a highly efficient method for making decisions on a compound or a series of compounds to move forward for further analysis.

The refinement or creation of new approaches may result in the elimination of existing activities. For example, the structure confirmation of newly synthesized lead compounds traditionally involved an extensive use of nuclear magnetic resonance (NMR). Once reliable LC/MS methodologies became available and their performance was benchmarked, they were soon accepted as an exclusive method for the rapid structure confirmation of lead compounds at an earlier stage of the lead identification process.

The likelihood of success, or failure, is an important strategic factor in drug development. Generally, drug development proceeds with a multitude of events and demands that superimpose onto organizational sequence, regulatory compliance, and diverse analysis needs. Thus, faster development timelines typically occur when outcomes are predictable. Drug development is often slowed by the unpredictable. In either case, opportunities exist for new methodologies to address unpredictable needs. Great skill, or perhaps fortunate circumstance, is required to anticipate needs and to devise effective plans.

So what happens when the pipeline is filled? Two examples illustrate the features of quantitative and qualitative process approaches, and the following sections describe the corresponding models for

accelerated drug development. Each model focuses on the dynamics of quantitative and qualitative approaches and emphasizes opportunities that impact analysis and the overall accelerated drug development situation.

QUANTITATIVE PROCESS PIPELINE

Figure 3.2 (top) shows a quantitative drug development pipeline that contains 100,000 lead compounds. In this hypothetical model, ten lead candidates are generated in the drug discovery stage. In the subsequent preclinical development activities, 80% of the lead candidates are successfully transferred to clinical development. The resulting eight IND/CTA candidates are presented to the clinical development stage, which involves three phases of evaluation. During this stage, 50% successfully pass through to phase II, and 50% of the phase II are successfully transferred to phase III. A single NDA/MAA results at the end of the pipeline, corresponding to a 50% success rate from phase III. In this model, every 100,000 lead compounds generated in drug discovery resulted in a single NDA/MAA.

The overall process can be analogously viewed as a multistep synthesis. Each step involves the critical evaluation of candidate properties for conversion to the next development stage. Each

| Lead Compound | Lead Candidate | IND/CTA | Phase I | Phase II | Phase III | NDA/MAA |
|---------------|----------------|---------|---------|----------|-----------|---------|
| 100,000 | 10 | 8 | 4 | 2 | 1 | |
| 200,000 | 20 | 16 | 8 | 4 | 2 | |
| 300,000 | 30 | 32 | 12 | 6 | 3 | |
| 400,000 | 40 | 40 | 16 | 8 | 4 | |

Figure 3.2 A quantitative process pipeline model, illustrating the transfer of successful drug candidates from one stage to the next. Quantitative increases in drug candidate sample-generation volume are complemented by proportional increases in resources for sample analysis. (Courtesy of Milestone Development Services, Newtown, Pa., USA.)

development stage has a corresponding *yield*, which is indicative of productivity. Each process has a corresponding *rate*, which is indicative of efficiency. The yield and rate are dependent on the starting material (i.e., volume and quality of the lead compound) as well as on the analysis tools and strategy used to generate the information that is necessary to convert candidates to the next development stage.

To illustrate the effects of a pure quantitative process approach to accelerated drug development, the pipeline is filled with more discovery leads while the qualitative process elements (i.e., rates of conversion) remain the same for each stage (bottom, Figure 3.2). In the first example, the number of lead compounds in drug discovery is doubled totaling 200,000. The results are arithmetic as each quantitative benchmark is doubled, resulting in the production of two NDA/MAA compounds. This model is extended further to illustrate the effects when 300,000 and 400,000 lead compounds are introduced into the drug development pipeline to generate three and four NDA/MAA compounds, respectively.

This approach to accelerated development emphasizes high throughput activities, and thus, sample volume is typically high. This approach targets specific end points and benchmarks that aim at increasing productivity. The strategy is based on introducing more lead compounds into the pipeline to obtain more NDA/MAA filings. The logic is highly intuitive; if the number of compounds entering the pipeline is doubled, then the number of compounds leaving is doubled as well. Thus, a quantitative process pipeline is volume enhancing and is driven by “thermodynamic” properties. An assumption is made that efficiency will be maintained as the sample volume is increased. For this relationship to occur, improvements in analysis throughput are required. Without these improvements, quantitative process approaches to accelerated drug development require a *proportional* increase in resources (i.e., personnel, instrumentation, space) for analysis.

QUALITATIVE PROCESS PIPELINE

Qualitative process approaches to accelerated development target the activities involved with converting (or eliminating) the drug candidate through the various development stages within the pipeline. Using the same 12-month model as described for a quantitative pro-

cess, a pipeline that contains 100,000 lead compounds is shown in Figure 3.3. In this approach, identical benchmarks for performance may be obtained; however, the potential of improving the overall efficiency via the elimination of weak drug candidates exists by producing 1 NDA/MAA in fewer than 12 months.

This approach is extended to target improvements with the rate of conversion between specific development stages. For example, Figure 3.3 illustrates the effect on overall productivity if the number of lead candidates that are transferred to the IND/CTA stage is reduced to six, corresponding to a 60% conversion rate. With two less compounds to support during the clinical development stage, a significant amount of resources can be saved. Figure 3.3 also illustrates the effect of qualitative process enhancements throughout the drug development pipeline without increasing the number of pre-clinical leads.

A qualitative process approach to accelerated development emphasizes the elimination of drug candidates from the pipeline. This approach targets the advanced evaluation of specific pharmaceutical properties. The reward is not necessarily intuitive; introduce a qualitative process change earlier in the drug development pipeline, resulting in the proactive identification of promising lead compounds and the utilization of fewer resources during the costly clinical development phases. This approach is driven by “kinetic”

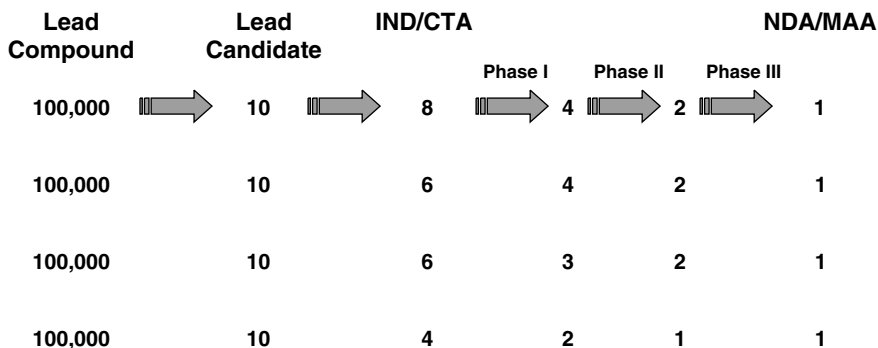

Figure 3.3 A qualitative process pipeline model, illustrating the elimination of unsuccessful drug candidates at earlier stages. Qualitative improvements in efficiency and the rate at which drug candidates flow through the pipeline result from the incorporation of new applications for drug candidate evaluation at earlier stages of drug development. (Courtesy of Milestone Development Services, Newtown, Pa., USA.)

properties with an acute focus on efficiency (i.e., time is money!). A key element of a qualitative process approach is the incorporation of new applications for drug candidate evaluation at early stages of drug development. This action provides a mechanism to regulate the flow of drug candidates through the development pipeline. In this way, rational decisions are made, resulting in the selection of specific drug candidates for accelerated (or delayed) development. Without this approach, traditional methods of sample analysis would be left to deal with the bulk of drug candidates and their corresponding samples.

MOTIVATING FACTORS

The motivation to implement quantitative and/or qualitative process approaches in drug development is understandable. A drug that generates \$1 billion in sales annually has approximately \$3 million sales per day. Therefore, the addition of an equivalent drug from a revenue standpoint is quite lucrative. This figure is derived from a pure quantitative process approach. When applied throughout an entire drug development pipeline, a qualitative process approach is equally profound. For example, for an organization operating with a \$1 billion research and development budget and producing two new chemical entities (NCEs) per year, the cost for developing a single NCE per year is about \$500 million per year. Therefore, development costs would equal \$2 million per day per NCE. This figure is consistent with cost estimates of bringing an NCE to market (Drews and Ryser 1997). The notion of accelerating the development of a \$1 billion drug is powerfully motivating and can result in a significant source of revenue. Furthermore, the early elimination of drug candidates for further development may result in considerable savings.

This analysis suggests that future accelerated drug development activities require quantitative and qualitative process considerations. Industry experiences suggest that an iterative relationship, if not balance, between the two approaches exist. Whatever the case may be, future approaches to accelerated drug development is likely to continue to focus on the number of compounds/candidates in each development stage and on the rate at which they flow through the pipeline. These features are likely to combine elements of quantitative and qualitative process approaches. An extension of the previously described hypothetical pipeline is shown in Figure 3.4 to

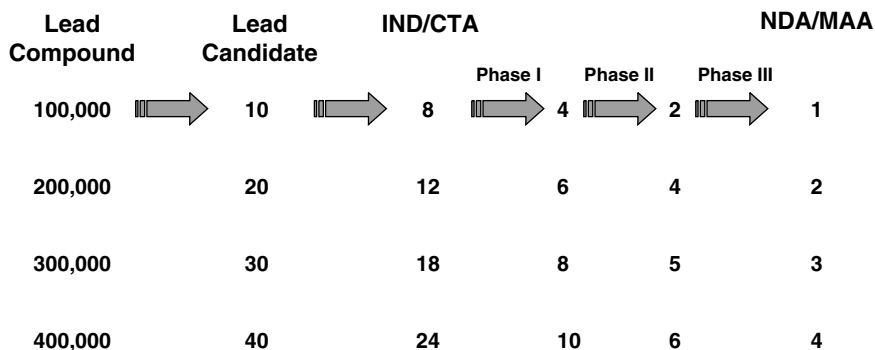

Figure 3.4 A combined process pipeline model, incorporating quantitative and qualitative elements. Combined approaches for drug development result in increased efficiency and rate with only moderate increases in resources due to strategic process changes. (Courtesy of Milestone Development Services, Newtown, Pa., USA.)

illustrate the dynamics of a combined quantitative and qualitative process approach. Combined approaches provide a synergistic mechanism to focus on goals for productivity and benchmarks for efficiency. Finally, these models indicate that combined quantitative and qualitative process approaches to accelerated development require strategic changes (affecting sample-generating and sample analysis activities) with only moderate increases in resources.

ANALYSIS OPPORTUNITIES FOR ACCELERATED DEVELOPMENT

What opportunities exist for accelerated development? Are these opportunities predictable? And what role can analysis techniques such as LC/MS play? Perhaps a straightforward approach involves the determination of analysis costs.

Full-Time Equivalent

The first step in calculating the cost of analysis in the pharmaceutical industry is to determine the yearly cost of the analyst. This cost is referred to as a full-time equivalent (FTE). A typical FTE calculation is shown in Figure 3.5. The cost per year can be estimated as an annual cost of about \$250,000, which would include factors for

| Budget | Annual | Productivity | (Days/Yr) | Cost |
|------------------------------|------------------|--------------------|--------------------|-------------------------------------|
| Salary | 65,000 | Working Days | 260 | |
| Benefits | 28,000 | Holidays | (13) | |
| Space | 52,000 | Vacations | (15) | |
| Support Staff and Management | 15,000 | Training | (5) | |
| Capital Equipment | 45,000 | Company Meetings | (15) | |
| Operating Supplies | 45,000 | Conferences | (5) | |
| | | Maintenance/Repair | (7) | |
| Total | \$250,000 | | 200 days/yr | \$1250/day \$156/h |

Figure 3.5 A calculation of the costs associated with a full-time equivalent (FTE) analyst. (Courtesy of Milestone Development Services, Newtown, Pa., USA.)

salary, benefits, space (laboratory, office, common rooms), management, support staff, capital equipment, and operating supplies, which increase or decrease the FTE cost. The time available to a researcher for sample analysis is estimated at approximately 200 days per year. This number takes into consideration the allotment of time for holidays, vacation, training, conferences, company business meetings, and maintenance and repair of laboratory equipment. This analysis provides a daily cost of about \$1250 per day for each productive researcher.

Sample Throughput Model

Once the figures for an FTE are established, the cost corresponding to the number of samples that can be analyzed per day is calculated. Figure 3.6, illustrates a cost profile for LC/MS analyses up to 100 samples per day. This model indicates analysis throughput from a quantitative process approach and provides a fiscal illustration of the impact the analysis may have on drug development. For example, LC/MS-based strategies, which have been demonstrated to increase the rate of sample analysis by 2- to 10-fold in the pharmaceutical industry, can be expected to reduce the cost per analysis by a corresponding ratio.

Elimination Model

A second model, which can be used to illustrate the cost advantages of LC/MS in drug development, highlights the fiscal benefit of qual-

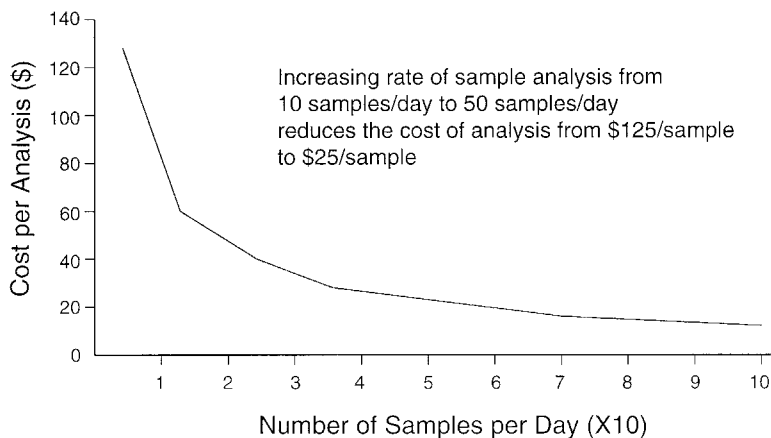

Figure 3.6 Fiscal illustration of the impact of analysis efficiency on drug development costs, based on the FTE costs indicated in Figure 3.5. An LC/MS application that increases the rate of sample analysis from 10 samples/day to 50 samples/day would reduce the cost of analysis from \$125/sample to \$25/sample. (Courtesy of Milestone Development Services, Newtown, Pa., USA.)

itative process approaches used to eliminate candidates from the drug development pipeline. In this example, the number of compounds in various stages of drug development is represented, using the previously described drug development pipeline models (Figures 3.2–3.4). From this model, the costs associated with each stage of drug development are estimated (Table 3.2). Assuming that the cost to develop a single drug candidate equals \$500 million per year, a figure for the cost per candidate is calculated for the three stages that lead up to NCE/MAA approval. For example, the cost of preclinical and clinical development is estimated at \$5 million and \$40 million, respectively.

From this information, the fiscal impact of qualitative process approaches is evaluated. For example, the amount of savings that result from the early elimination of a single drug candidate that would have failed in clinical development is illustrated in Figure 3.7. Clearly, there are strategic opportunities to select or eliminate candidates at earlier stages of drug development. This analysis reveals the savings that result from the elimination of two compounds from the clinical development stage, totaling \$80 million.

TABLE 3.2 A model projecting the yearly costs associated with the first three stages of drug development

| | Drug Discovery | Preclinical Development | Clinical Development |
|---|----------------|-------------------------|----------------------|
| Number of drug candidates | 100,000 | 10 | 8 |
| Estimated cost of development ^a (\$) | 150M | 50M | 300M |
| Cost per drug candidate (\$) | 1500 | 5M | 40M |

Source: Courtesy of Milestone Development Services, Newtown, Pa., U.S.A.

^a Assuming the cost to develop a single new drug equals \$500M/yr.

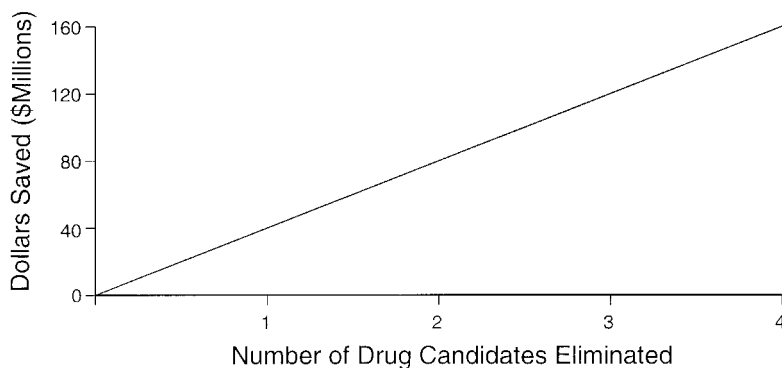

Figure 3.7 Cost savings associated with the early elimination of drug candidates that would have failed in clinical development. Early elimination of two drug candidates would save approximately \$80M within a year. (Courtesy of Milestone Development Services, Newtown, Pa., USA.)

Rate-Determining Event Model

Trends in accelerated drug development illustrate the important role of LC/MS technology. As prospective LC/MS analysis approaches continue to be accepted, more activities that are identified as rate determining can be investigated. These rate-determining events correspond to proteomics for drug target identification, combinatorial chemistry, and pharmacokinetics, to name a few. These areas continue to undergo quantitative and qualitative process refinement for

additional gains in productivity and efficiency. Future approaches to accelerated drug development may focus on activities that do not routinely use LC/MS. These activities may include screening, solubility, absorption, formulation screening, stability, process research, toxic mechanisms, and direct patient monitoring, for example. As these rate-determining activities are accelerated with the application of LC/MS techniques, the cost savings can be highly significant.

For example, if a hypothetical drug development pipeline contains a total of 20 rate-determining activities, then the application of LC/MS for accelerated development can be measured (Figure 3.8). Using the same model of a drug with \$1 billion in annual sales (\$3 million per business day), the additional income associated with earlier introduction of the drug is calculated. In this model, the application of LC/MS on 10 rate-determining activities that result in 2 days of accelerated development per activity allows the launch of the drug to proceed 20 days earlier, for additional sales that total \$60 million.

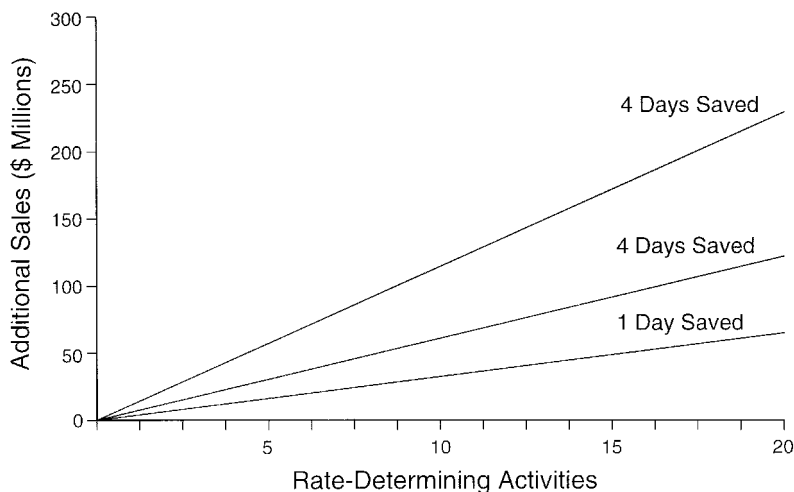

Figure 3.8 Additional sales associated with an earlier introduction of a new drug due to saving days of work from rate-determining activities during the drug development process. Two days saved for each of 10 rate-determining activities would allow the introduction of the drug 20 days earlier, and would result in \$60M additional sale for a drug with \$1 B/year sales. (Courtesy of Milestone Development Services, Newtown, Pa., USA.)

ACCELERATED DEVELOPMENT PERSPECTIVES

The risk in drug development is tremendously high. Thousands of lead compounds are synthesized and tested. Perhaps only 1 in 100,000 lead compounds is introduced into clinical trials. Only 1 in 10 lead candidates is registered and marketed. Such a high degree of failure is further exacerbated when one realizes that only one in three marketed drugs returns its research and development (R&D) investment. Therefore, there exists a great deal of motivation to constantly evaluate drug development activities and to integrate new approaches that provide advantages for faster development and economical research. This motivation has led the pharmaceutical industry to search for new opportunities that deal with analysis and accelerated development.

The successful application of new technologies to drug development is noteworthy. Although the end result cannot be reliably predicted, each application has its origin with some specific development crisis. Crisis creates a poignant stoppage in workflow and a bottleneck in drug development. Bottlenecks demand a search for something new.

CHAPTER 4

LC/MS DEVELOPMENT

The significant events and overcome obstacles that led to the development and application of LC/MS based techniques (Snyder, 1995; Covey, 1995; Thomson, 1998) and the mechanistic aspects of ionization (Bruins 1994; Bruins, 1998) have been reviewed. Efforts to develop and refine an interface for introducing a flowing liquid high performance liquid chromatography (HPLC) system into a high vacuum mass spectrometry environment were fueled by a strong notion that the combination would be unique and would provide powerful advantages for analysis (Arpino et al., 1979; Arpino, 1982). The combined efforts and vision from a diverse group of pioneering researchers helped to create a unique combination for pharmaceutical analysis.

THE ELEMENTS OF LC/MS APPLICATION

From an applications standpoint, the partnership of HPLC and mass spectrometry benefited greatly from the tradition of HPLC within the pharmaceutical industry and from the growing trend to obtain structural and quantitative information during earlier stages of drug development. Ultimately, it has been the power of HPLC to resolve and the ability of mass spectrometry to identify that enabled LC/MS to integrate effectively with drug development and to solve prob-

lems. The integrated LC/MS format provides the pharmaceutical industry with a highly efficient platform to conduct a series of on-line steps to purify the sample and amplify the signal.

HPLC

HPLC-based techniques have been a traditional mainstay of the pharmaceutical industry. It is a powerful technology that allows complex mixtures to be transformed into separated components. It is highly sensitive, reproducible, accessible, and well understood from an operator's standpoint. Perhaps the output from the HPLC is its unique characteristic that distinguishes it from all other analytical techniques. The output from an HPLC, the chromatogram, is defined and simple. Each peak is characteristic of a component; each chromatogram is diagnostic of an event or experiment associated with a drug development activity. When combined with the facts that nearly all compounds of pharmaceutical interest are amenable to HPLC methodologies and conditions and that critical information on nearly all events in the drug development cycle can be derived from HPLC chromatograms, it becomes evident why HPLC is a universally accepted analysis tool.

Mass Spectrometry

Until the widespread commercial introduction of electrospray ionization (ESI)-LC/MS instruments in the early 1990s, mass spectrometry-based techniques had a functional yet limited role in drug development. Primarily geared toward a medicinal chemistry environment, mass spectrometry was a fairly routine tool for molecular weight determination and a specialty tool for complex structure identification problems. Applications and methods were typically defined by the ionization method of choice. Fast atom bombardment (FAB), desorption chemical ionization (DCI), chemical ionization (CI), and electron ionization (EI) were the predominant choices, with varying degrees of applicability. Once a molecule is ionized, the mass spectrometer provided separation of the resulting molecular ions and dissociation products, according to weight. These masses were assigned to corresponding substructures of the molecule. These approaches were primarily limited to the characterization of low molecular weight compounds (<500 Da) with varying degrees of polarity and thermal lability. Detailed analysis was defined by the

depth of spectral interpretation for structure identification purposes or by the resolving power of the instrument for exact mass, molecular formula, and purity assessment.

LC/MS Interface

The LC/MS interface provides the connection between the HPLC and the mass spectrometer. It is responsible for the reliable and efficient transfer of analytes from the solution phase to the gas phase. It is also responsible for a critical element of mass spectrometry analysis: ionization. For most pharmaceutical analyses, the ideal ionization technique would generate a single ion that corresponds to the molecular weight of the drug compound, with little or no fragment ions. The confirmation of structure would be facile and quantitation would proceed with a high degree of sensitivity. Elements of selectivity would be provided by the HPLC separation (i.e., drug components, biological matrix) and/or MS/MS (i.e., structure elucidation, enhanced quantitation).

In the late 1980s, thermospray ionization (TSI) techniques offered what would be the precursor to a universal and reliable LC/MS interface for compounds of pharmaceutical interest. Conventional HPLC flow rates (1–2 mL/min) were accommodated by this interface, using volatile buffers that contain ammonium acetate. New applications were realized, and higher standards of analytical performance were established for pharmaceutical analysis (Voyksner et al., 1985; Beattie and Blake, 1989; Oxford and Lant, 1989; Malcolm et al., 1990; Bowers et al., 1991).

However, TSI-LC/MS applications did not completely capture the imagination of chemists and biologists in the pharmaceutical industry. TSI-LC/MS was overshadowed by its unpredictable performance and questionable ruggedness when compared to HPLC with ultraviolet (UV) detection. This perception was the case, in part, because pharmaceutical researchers were ready for a universal LC/MS system, but with very few limits. Simple methods to handle small and large molecules, combined with a gentle technique for ionization, were needed. Researchers were not content with the unique capabilities of TSI-LC/MS. They wanted few boundaries for applicability with familiar levels of analytical performance (i.e., similar to LC/UV). This requirement was not necessarily derived from an analytical perspective, but rather an industry perspective, which ultimately forms the basis of acceptance. Whether this requirement

was fair or unfair is perhaps another topic for discussion; however, the developments associated with the TSI-LC/MS interface were indeed quite significant and made clear two significant aspects of LC/MS technologies during the late 1980s: (1) the pharmaceutical industry was ready for LC/MS applications, and (2) clear performance benchmarks for acceptance were established for future instruments.

From a medicinal chemist's perspective, nuclear magnetic resonance (NMR) was still the analytical tool of choice, whereas mass spectrometry, infrared (IR), and elemental analyses completed the necessary ensemble of analytical structure confirmation. Synthesis routines were capable of generating several milligrams of product, which is more than adequate for proton and carbon NMR experiments. For analyses that involved natural products, metabolites, or synthetic impurities, time-consuming and often painstaking isolation methods were necessary, followed by expensive scale-up procedures, to obtain the necessary amount of material for an NMR experiment. In situations that involved trace-mixture analysis, radiolabeling approaches were often used in conjunction with various formats of chromatographic separation.

The original work of Bruins (Bruins et al., 1987) and Fenn (Fenn et al., 1989) revealed the promise of an LC/MS interface that satisfied the industry requirements of applicability and performance. Examples ranged from the atmospheric pressure chemical ionization (APCI)-LC/MS analysis of small drug molecules (Bruins, 1991; Baillie, 1992) to the ESI-LC/MS analysis of biomolecules (Hunt et al., 1992; Yates et al., 1993) and receptor-ligand interactions (Ganem et al., 1991; Ganguly et al., 1992; Smith and Light-Wahl, 1993). These applications demonstrated a widened scope of LC/MS utility for pharmaceutical analysis and set new standards for performance. Perhaps equally important, these early applications of APCI-LC/MS and ESI-LC/MS captured the imagination of pharmaceutical researchers and created a powerful perception that MS-based techniques could have an expanded role as a versatile tool for drug development.

Extensions of the ESI interface led to miniaturized formats, microelectrospray (Emmett and Caprioli, 1994) and nanoelectrospray (Wilm and Mann, 1996), applied specifically for peptide mapping. Microelectrospray was developed for use with capillary chromatography formats or direct infusion at flow rates 200–700 nL/min. Nanoelectrospray formats are operated at 20–70 nL/min and the flow is caused solely by the ESI voltage.

LC/MS GROWTH

Once designed, tested, manufactured, and championed, an explosion in pharmaceutical applications that involve LC/MS soon began. This growth is illustrated by the number of papers that feature LC/MS (Figure 4.1) and that have been presented at the American Society for Mass Spectrometry (ASMS) conference during the past 10 years. The total number of papers has steadily increased during this time, with significant increases in LC/MS papers. For example, in 1998 LC/MS presentations at the ASMS conference in Orlando, Florida, comprised nearly 30% of the total papers. Pharmaceutical applications of LC/MS exhibited a similar growth and represented nearly 15% of the total papers presented in 1998.

The rapid growth of LC/MS experienced in the pharmaceutical industry was in many ways fortuitous. Development of the LC/MS interface coincided with industry initiatives that made it imperative to understand, acquire, and integrate this technology into the drug

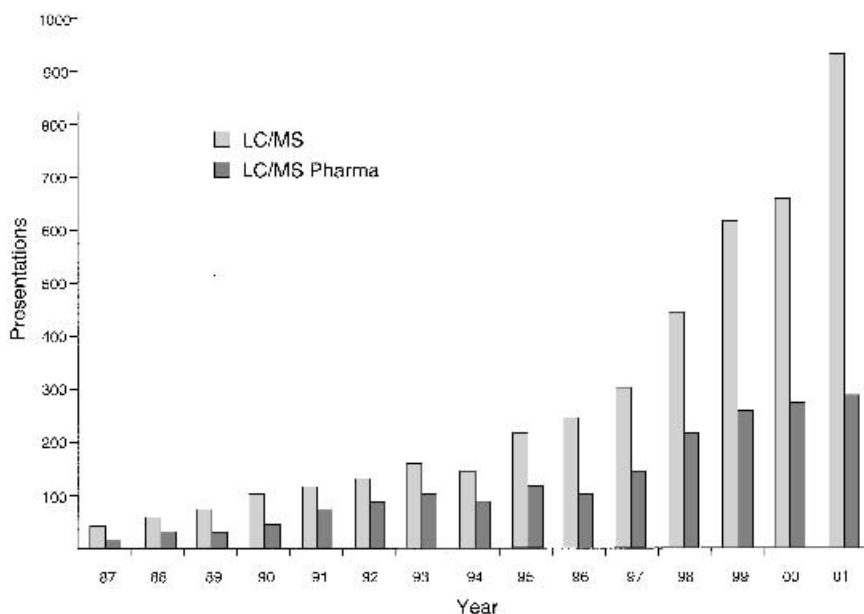

Figure 4.1 The growth in presentations at the annual conference of the American Society for Mass Spectrometry featuring all LC/MS applications (LC/MS) and LC/MS applications in drug development (LC/MS Pharma). (Courtesy of Milestone Development Services, Newtown, Pa., USA.)

development cycle. There did not exist an alternate method or approach to obtain LC/MS-derived information that had the same impact on drug development. The faster rate of sample generation combined with cost-saving initiatives that emphasized efficiency helped to make LC/MS-based solutions an easily justifiable approach.

The LC/MS instrument has become a highly productive analysis platform for drug development activities due to: (1) technological advances in the LC/MS interface, (2) improved HPLC and mass spectrometer performance, and (3) an increased need for rapid, high-throughput analysis of trace mixtures. During the past decade, we have witnessed the successful introduction of a variety of LC/MS instruments into drug development that feature single quadrupole, tandem quadrupole, magnetic sector, time-of-flight (TOF), and ion trap mass analyzers. Dedicated instruments for highly specialized analyses (i.e., high throughput quantitation) to instruments residing on the laboratory bench (i.e., open-access, reaction-monitoring stations) are now a significant part of the modern drug development landscape. Negative perceptions that mass spectrometry-based techniques were time-consuming, limited in application, and difficult to operate and maintain became a memory of the past.

In a relatively short time, LC/MS has truly come a long way. Furthermore, its growth has helped set the stage for parallel analysis opportunities with matrix-assisted laser desorption/ionization (MALDI) (Stoeckli et al., 1999; Griffin et al., 2001), capillary electrophoresis (CE) (Chakel et al., 1997; Figeys and Aebersold, 1998), LC/NMR (Ehlhardt et al., 1998; Vogler et al., 1998; Shockcor et al., 2000), and in general, simpler, less expensive instruments. Certainly, carry-over perceptions in the pharmaceutical industry still exist; but, if instrument sales are a good indicator, then there seems to be a growing population of believers in LC/MS-based tools for analysis.

LC/MS technologies continue to experience an expanding role in drug development. High premiums on fast analysis times and the rapid turnaround of results have resulted in immense challenges and opportunity. New standards for throughput and capacity continue to be established. The early and quick evaluation of drug candidates has now become the norm throughout the pharmaceutical industry. Everything seems faster.

To reach the required level of analysis performance with LC/MS techniques, new strategies for analysis are required. The challenge of coordinating this activity cannot be underestimated because these

strategies often determine the ultimate success of the analysis method and provide a mechanism for an entire organization to interact with the information generated. Without an appropriate strategy, the results are useful only to those who generated the data. Thus, the creation and selection of effective strategies for analysis have become critical factors in drug development.

CHAPTER 5

STRATEGIES

An exciting element of LC/MS growth has been the development of effective strategies for analysis. Unprecedented needs in drug development stimulated new ways of providing information. Shorter timelines and a greater number of drug candidates resulted in a tremendous focus on streamlined approaches that generate information for decision making. This approach allows decision makers to readily obtain, or even request, the necessary information that leads to accelerated development. Thus, the emphasis in LC/MS strategies in drug development is on producing information appropriate for decision.

Accelerated drug development applications incorporate key strategies that define the attributes of the resulting method. Selection and incorporation of these strategies into the LC/MS method is highly dependent on the specific need or task. As a result, the strategies that are ultimately incorporated into a method may seem obvious and may not be often enumerated. However, a fundamental understanding of these strategies can assist with the development of highly effective methods for analysis.

Nine strategies consistently appear in LC/MS-based methods for accelerated development (Table 5.1). The nine strategies are: standard methods, template structure identification, databases, screening, integration, miniaturization, parallel processing, visualization, and

TABLE 5.1 The nine strategies that consistently appear in LC/MS-based methods for accelerated drug development

| Strategy | Analytical Focus | Industrial Application |
|---|---|---|
| Standard methods Template structure identification Databases | Method development (molecular structure) | Qualitative and quantitative analysis |
| Screening Integration Miniaturization | | |
| Parallel processing Visualization Automation | | |
| | Analytical formal (instrumentation and peripheral hardware) | Drug function/interaction and pharmaceutical properties |
| | Information and sample processing (throughput) | Efficiency and productivity |

Source: Courtesy of Milestone Development Services, Newtown, Pa., U.S.A.

automation. The strategies can be organized into three distinct method sets based on the application and analytical emphasis. For example, LC/MS methods that involve the use of standard methods, template structure identification, and databases are often performed in concert. These strategies focus on the structure of the molecule(s) of interest and are typically the foundation for qualitative and quantitative analysis applications. Screening, integration, and miniaturization strategies are also often performed in concert and tend to focus on drug molecule(s) function with the purpose of generating a relative ranking (Tamvakopoulos et al., 2000) for a specific pharmaceutical property. The strategies that involve parallel processing, visualization, and automation are each capable of being applied, separately or in concert, with any strategy (or strategies). This method set focuses on high throughput applications where increased efficiency is required.

The nine strategies form a powerful set of tools to devise, construct, and refine pharmaceutical analysis methods. The proactive use of a single strategy, or the combination of several, produces unique information and inspires new perspectives on analysis. In this way, analysis methods create new mechanisms for information gathering, rather than passively *waiting* for a sample to be generated. And in this way LC/MS analysis capabilities partnered with sample-generating disciplines to create new accelerated development opportunities.

The following sections describe the nine analysis strategies and give examples of how they are typically used to accelerate drug development. Selected references are listed in Table 5.2 to illustrate participation with specific drug development stages. Many of the examples referenced here are described in the applications section. Each strategy represents a significant process change that affects the number of samples analyzed and the rate of compounds that flow through the development pipeline.

STANDARD METHODS

Method development and validation are two of the most time-consuming aspects of analysis-related activities. Furthermore, if a system is used for more than one analysis, then the time required for changeover from one set of conditions to another can actually be more time consuming than the analysis! Increasingly, the desire for customized methods has yielded to the demands of increased sample generation. This demand resulted in the introduction of standard methods, sometimes referred to as “generic methods” (Ayrton et al., 1998b; Dear et al., 1998), to accommodate a wide range of compound classes. This strategy allows the same set of conditions to be used on diverse samples and reduces the time required for method development, validation, and experimental setup. Some reduction in chromatographic resolution may be experienced compared to a customized method; however, the separations are often sufficient to provide the appropriate information for decision making. Generally, this approach does not replace existing methods; however, it provides for the necessary throughput plus new options for accelerated drug development. Also, methods are locked in during early development stages for faster project start-up. This strategy eliminates iterative cycles of method development and refinement. This approach was demonstrated for lead optimization in the drug discovery stage (Korfmacher et al., 2001; Olah et al., 1997) and in situations where a drug candidate enters a new stage of evaluation (Kerns et al., 1997; Bansal and Liang, 1998).

One standard method approach that appears to have wide application in the pharmaceutical industry is the use of reversed-phase high performance liquid chromatography (HPLC) with a wide solvent gradient program. For example, a linear gradient from 95%

TABLE 5.2 Applications of LC/MS that highlight the use of a specific strategy within the four stages of drug development

| Analysis Strategy | Drug Development Application | Development Stage | Selected References |
|---------------------------------|--------------------------------|-------------------|---|
| Standard methods | Open-access | DD | Taylor et al., 1995; Pullen et al., 1995 |
| | Pharmacokinetics | DD | Olah et al., 1997 |
| | Metabolite identification | PD | Kerns et al., 1997 |
| | CYP450 metabolism | CD | Ayrton et al., 1998 |
| | Natural products | DD | Lee et al., 1996 |
| | Degradants | PD | Volk et al., 1997 |
| | Degradants | CD | Qin et al., 1994; Volk et al., 1996 |
| | Impurities | CD | Nicolas and Scholz, 1998; Williamson et al., 1998 |
| | Metabolites | CD | Dear et al., 1998 |
| | QC/proteins | M | Cheng et al., 1997 |
| Databases | Library searching | DD | Henzel et al., 1993; Eng et al., 1994; Arnott et al., 1995; McCormack et al., 1997; Kleintop et al., 1998 |
| | Natural products dereplication | DD | Gilbert and Lewer, 1998; Janota and Carter, 1998 |
| | Impurity identification | PD | Kerns et al., 1994 |
| | Substructure nomenclature | PD | Kerns et al., 1995 |
| | Glycoprotein mapping | DD | Carr et al., 1993 |
| | Phosphorylated peptides | DD | Ding et al., 1994 |
| | Target screening | DD | Hsieh et al., 1997 |
| | Drug-protein binding | DD | Tiller et al., 1995 |
| | Pharmacokinetics | DD | Olah et al., 1997; Bryant et al., 1997; Hop et al., 1998; Beaudry et al., 1998; Allen et al., 1998 |
| | Screening | Caco-2 models | DD |
| Metabolic stability | | DD | Ackerman et al., 1998; Davis and Lee, 1998 |
| In vitro metabolites | | DD | Poon et al., 1996 |
| Bioaffinity screening | | DD | Davis et al., 1999 |
| Predictive models | | DD | Rourick et al., 1996; 1998; Jurva et al., 2000 |
| Toxicology | | PD | Stevens et al., 1997 |
| Toxicology | | CD | Maurer et al., 1997 |
| Sulfates/glucuronides | | CD | Bean and Henion, 1997 |
| Peptide mapping | | DD | Heath and Giordani, 1993 |
| Multidimensional chromatography | | DD | Apffel et al., 1995; 1996; Link et al., 1998; Washburn et al., 2001 |
| Integration | Metabolism | DD | Li et al., 1995 |

| | | | |
|---|--|----|---|
| Metabolic stability | | PD | Herron et al., 1995; Wood et al., 1996; Heath et al., 1997; Manimi et al., 1998 |
| Pharmacokinetics | | CD | Covey et al., 1986; Fouda et al., 1991; Wang-Iverson et al., 1992; Kaye et al., 1992; Hoke et al., 2001 |
| In vivo microdialysis | | CD | Scott and Heath, 1998; Wong et al., 1999 |
| Biotransformation | | CD | Chen et al., 1991 |
| Direct analysis of plasma | | CD | Ayrton et al., 1997; Needham et al., 1998 |
| On-line immunoaffinity extraction | | CD | Cai and Henton, 1997 |
| Chiral analysis | | CD | Kanazawa et al., 1998; Joyce et al., 1998 |
| Impurities | | CD | Evans et al., 2001 |
| Organic extractables | | M | Wu et al., 1997 |
| Peptide mapping | | DD | Liu et al., 1998 |
| Protein identification | | DD | Wolters et al., 2001 |
| Glycoprotein mapping | | DD | Liu et al., 1996 |
| Cellular uptake | | DD | Kerns et al., 1998 |
| In vitro hydrolysis | | DD | van Breemen, et al., 1991 |
| Biotransformation | | DD | Tiller et al., 1998 |
| In vitro biotransformation | | PD | Beattie and Blake, 1989 |
| Impurities | | PD | Liu et al., 1997 |
| Biotransformation | | CD | Ackerman et al., 1996b |
| Chiral separations | | CD | Zavitsanos and Alebic-Kolbah, 1998 |
| 96-well SPE | | CD | Kaye et al., 1996 |
| Protein analysis | | DD | Houhaeve et al., 1995 |
| Predictive models/degradants | | PD | Rourick et al., 1996 |
| Off-Line SPE | | CD | Allanson et al., 1996; Simpson et al., 1998 |
| Natural products | | DD | Ackerman et al., 1996a |
| Combinatorial chemistry | | DD | Tong et al., 1998; Richmond et al., 1999; Yates et al., 2001 |
| Peptide mapping | | DD | Armott et al., 1995 |
| Protein Analysis | | DD | Houhaeve et al., 1997 |
| Protein purification | | DD | Feng et al., 2001 |
| Peptide sequencing | | DD | Taylor and Johnson, 2001 |
| Combinatorial library purity assessment | | DD | Zeng and Kassel, 1998 |
| Metabolite identification | | DD | Lopez et al., 1998 |
| Impurities | | PD | Josephs, 1996 |
| SPE extraction | | CD | Allanson et al., 1996; Janiszewski et al., 1997; Simpson et al., 1998 |
| Impurities | | M | Eckers et al., 1997 |
| Toxic leachables | | M | Tiller et al., 1997 |

Note: DD = drug discovery; PD = preclinical development; CD = clinical development; M = manufacturing.

aqueous/5% organic to 5% aqueous/95% organic at near neutral pH (i.e., 6–7) is typical. Often, a fast gradient (5 and 20 min) is used to provide rapid analysis.

An important element of this strategy is the application of the so-called 80/20 Rule, also known as Pareto's Law (Heller and Hindle, 1998), for method development and performance (Lee et al., 1995a; 1997). This approach basically targets a practical benchmark for performance where the method is applicable to about 80% of the samples analyzed. Analysis is initiated with minimal time spent on development and refinement activities. The strategy is to spend 20% of analysis time on 80% of the samples, whereas the majority of time (i.e., collaboration, method development, interpretation) can be spent on more challenging analyses representing 20% of the samples. The strategy can be refined and the scale set to the desired level of performance, such as 90/10 or 95/5. For the samples that are not successfully analyzed using this method, a backup 80/20 method is used (Lee et al., 1995a). Using this method-ensemble approach, maximum information is generated in the shortest amount of time and with minimal resources.

A standard method allows information to be collected in a consistent manner. Thus, information generated on one day is reliably compared to information generated on another. This consistency is an important consideration, particularly for those compounds that enter late stages of drug development, because useful information acquired 1–3 years earlier is used to accelerate development. Therefore, this strategy also results in a significant reduction of reanalyses. An example that involves a series of process research experiments performed by a chemist over several weeks illustrates this strategy. If, in the first sample, a drug impurity is identified using LC/MS and HPLC with tandem mass spectrometry (LC/MS/MS) studies, then it may only be necessary in subsequent samples to confirm the molecular weight of an impurity at the same retention time, using a single LC/MS or LC/UV analysis (Kerns et al., 1994). This approach was successfully implemented for metabolite identification during the preclinical development stage (Kerns et al., 1997).

TEMPLATE STRUCTURE IDENTIFICATION

The identification of unknown structures can often seem daunting, particularly when an authentic standard is not available. As a result,

impurities, degradants, and metabolites have often been prospectively synthesized. To support accelerated development, where 40 times as many samples can be generated, a more streamlined approach for structure identification must often be implemented.

One strategy involves the use of the parent drug itself as a template for the interpretation of unknown structures (Perchalski et al., 1982; Covey et al., 1991). This approach often provides sufficient information for early decision making in drug discovery. Confirmation for registration purposes (i.e., new drug application/marketing authorization application) is performed using a synthesized standard, as a project enters later stages of drug development.

Template structure identification is readily performed with LC/MS/MS using a consistent protocol. First, the parent drug is analyzed with LC/MS. Retention time and molecular weight information are obtained. Using LC/MS/MS, a product ion analysis of the parent drug is obtained, and specific product ions and neutral losses are assigned to substructures of the molecule. Thus, the unique fragment ions contained in the product ion mass spectrum of the parent drug serves as the *template* for identification. An example that illustrates this template structure identification strategy is shown in Figure 5.1 for paclitaxel (Volk et al., 1997). The figure, diagnostic product ions at m/z 286, 268, and 240 indicate the presence of the paclitaxel side chain. The m/z 509 ion in the degradant is indicative of the deacetylated paclitaxel core ring structure. The presence of the m/z 527 ion instead of the m/z 569 ion of paclitaxel indicates the loss of an acetyl substructure from the core ring structure. This result is consistent with the MW difference of 42 Da of the degradant, which is indicative of an acetyl substructure. Subsequent analysis of samples via LC/MS and LC/MS/MS yielded comparable information for the unknown compound(s).

By observing sequential neutral losses, further information is obtained to determine the sequence of substructures or molecular connectivity within the analyte (Lee et al., 1996). This procedure is analogous to two-dimensional nuclear magnetic resonance (NMR) techniques used to sequentially connect substructures. A familiar example of molecular connectivity is the determination of the amino acid sequence of a peptide. Specific neutral losses are diagnostic of specific amino acids, and the sequence of these losses identifies the peptide (Roepstorff and Fohlman, 1984).

The MS/MS identification strategy is based on the premise that much of the parent drug structure will be retained in the metabolites, impurities, or degradants (Perchalski et al., 1982; Lee et al.,

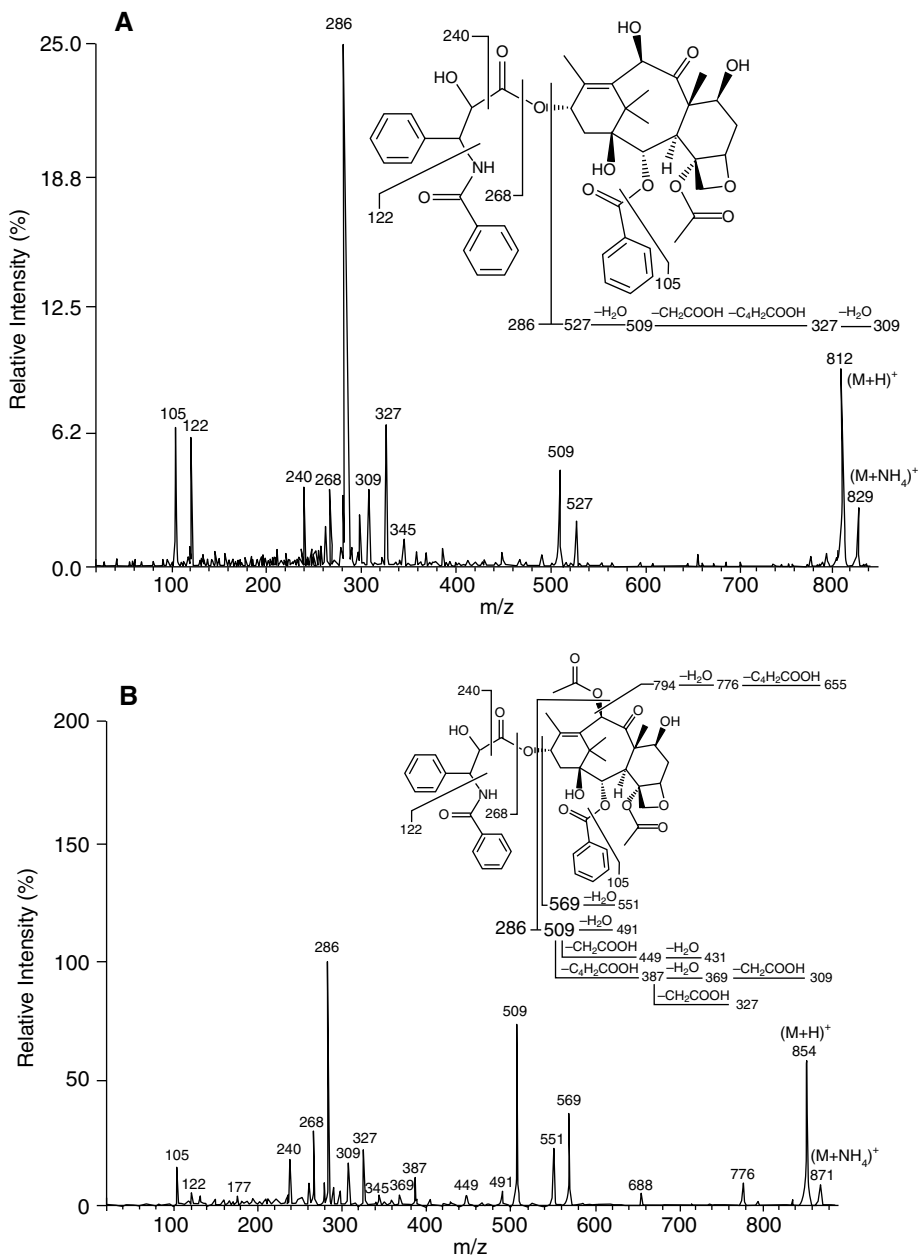

Figure 5.1 Template structure identification of a base-induced degradant of paclitaxel. (A) Product ion spectrum of the ion at m/z 829 ($H+NH_4$)⁺ of a base-induced degradant of paclitaxel. (B) Product ion spectrum of the m/z 871 ($H+NH_4$)⁺ ion of paclitaxel used as a template. The product ions and neutral losses that correspond to specific substructures are indicated. (Reprinted with permission from Volk et al., 1997. Copyright 1997 Elsevier.)

1986; Straub et al., 1987; Lee and Yost, 1988). In addition, the products associated with a unique substructure(s) are also expected to be retained. Direct comparison of molecular weight and products reveal substructural differences and lead to an interpreted or proposed structure.

This strategy is highly successful for impurity identification (Kerns et al., 1995) during preclinical development. When information is stored within a comparative database, this approach is also highly effective for protein identification (Arnott et al., 1995). In these applications, the characteristic fragmentation corresponding to amino acid residues provides the searchable template for identification. This approach is particularly useful when identification studies are required for vast numbers of compounds or for samples that contain many analytes of interest.

DATABASES

One strategy for taking advantage of (leveraging) processed information is to categorize it into databases. Although a modest amount of time and resources is required to implement this strategy, databases have two important benefits. First, they provide a reference-friendly format to search data. This feature is essential for the rapid identification of known compounds. For example, the identification of a metabolite may require only retention time and molecular weight information via LC/MS analysis when compared to the metabolite structure database compiled from previous LC/MS/MS studies (Kerns et al., 1997). The process of identifying a natural product in a plant extract, when the natural product has been previously identified and recorded in the database, is often referred to as *dereplication*. Gilbert and Lewer (1998) and Janota and Carter (1998) have described this approach. Databases are also used to search for known proteins (Eng et al., 1995). These databases are used extensively for the rapid identification (dereplication) of proteins in studies involved with proteomics (Arnott et al., 1995; Kleintop et al., 1998).

A second benefit of databases is the efficient extraction of information. The database may be "mined" to detect trends that may not be otherwise noticed. This approach is used to reveal trends such as the metabolically active sites of a molecule and/or a substructure labile to degradative conditions (Kerns et al., 1997). This informa-

tion is useful for candidate selection and development planning activities.

Once established, a database is transferred to other laboratories participating in the specific drug development activity. The resulting databases are readily accessed via information intranets. Information is coordinated within the database, and a variety of scientists pool their information. When implemented early within the drug development cycle (i.e., drug discovery), valuable information for late stages of drug development is available (Kerns et al., 1994; 1997). Therefore, this approach provides a comprehensive method for information gathering whereby future projects are planned, coordinated, and efficiently supported.

It should also be noted that database creation, modification, and use are greatly benefited by the standard methods approach described previously. This approach produces reliable data that lend themselves to a highly consistent database format throughout a project lifetime.

SCREENING

The acceptance of standard methods for analysis, template structure identification, and databases has allowed increased amounts of information to be generated in shorter periods of time. As researchers embraced approaches calling for the earlier collection of information on pharmaceutical properties, LC/MS emerged as an advantageous technique for screening. For example, to maintain adequate sample throughput and turn around, a variety of screening-based approaches are used. Results are either geared toward *categories* of performance (i.e., high, low) or absolute criteria such as a specific structure or targeted level of quantitation. Corresponding limits are preset during method development, and the LC/MS-based analysis merely sorts the information in a high volume fashion. Important elements of LC/MS screening feature quantitative and qualitative process approaches.

Screening-based strategies are incorporated into quantitative bioanalytical assays to provide a highly selective approach for high throughput analysis. Highly automated methods featuring fast chromatographic separations in combination with either one or two dimensions of mass spectrometry analysis provide powerful methods for quantitative analysis. The two approaches are referred to as

selected ion monitoring (SIM) and selected reaction monitoring (SRM). In experiments that use SIM, the mass spectrometer is set to detect a selected ion mass that corresponds to the drug molecule. Sensitivity is enhanced by using this selected ion drug screening approach as opposed to sampling a range of ions via a conventional mass spectrum (Fouda et al., 1991; Wang-Iverson et al., 1992). To provide higher selectivity and to enhance the limits of detection (LOD), SRM is used to screen for a compound by monitoring the ion current between a specific precursor-product ion relationship (Covey et al., 1986). A specific product ion resulting from unimolecular decomposition or a collisionally induced dissociation (CID) of the protonated molecule ion $(M+H)^+$, is detected (Kaye et al., 1992).

High throughput methods for metabolic stability assessment have been introduced early in the drug discovery stage in close proximity to compound synthesis activities (Cole et al., 1998; Ackermann et al., 1998). Analyses often incorporate a screening motif associated with the method of analysis, collection of information, and the subsequent interpretation of results. Similar approaches to rapidly generate and identify large numbers of related compounds (i.e., impurities, degradants, metabolites) employ predictive models (Rourick et al., 1996). Typically, these methods involve the incubation of the drug candidate in an *in vitro* model that is indicative of a condition encountered during drug development. For example, some methods incorporate metabolizing microsomes, acidic/basic/oxidizing chemical degradation conditions, or light/heat/humidity environmental conditions. Another LC/MS-based screening approach features the use of HPLC columns that contain an immobilized protein to determine relative binding. Tiller et al. demonstrated the use of this LC/MS methodology for the determination of drug-protein (serum albumins) binding (Tiller et al., 1995) (Table 5.3).

These screening approaches require minimum information for the evaluation of pharmaceutically relevant properties. Compounds that do not meet a predetermined criterion are eliminated from further consideration. Guidance is obtained for further structure optimization via synthetic modification. Thus, pharmaceutical properties are assessed on the timescale of compound synthesis, resulting in an optimization while programs are still active. Therefore, unfavorable candidates are eliminated early and resources are focused on more promising drug candidates.

Two-dimensional mass spectrometry screening approaches have

TABLE 5.3 Results from an LC/MS-based drug-protein binding screen using HPLC columns containing immobilized human serum albumin to determine the relative binding of drugs

| Drug | Molecular Weight | % binding | t_r | k' | $k'/(k' + 1)$ |
|-------------------|------------------|------------------|-------|--------|---------------|
| Glucose | 180 | 0 | 1:15 | — | — |
| Salbutamol | 239 | 7.5 ^c | 1:24 | 0.187 | 0.157 |
| Pyridoxin | 169 | 10 ^b | 1:26 | 0.229 | 0.186 |
| Tinidazole | 247 | 12 ^b | 1:24 | 0.187 | 0.157 |
| Paracetamol | 151 | 24 ^b | 1:33 | 0.375 | 0.273 |
| Phenacetin | 179 | 33 ^a | 1:53 | 0.792 | 0.442 |
| Cefuroxime-Axetil | 510 | 40 ^a | 1:59 | 0.916 | 0.478 |
| Triamterene | 253 | 57 ^b | 3:19 | 2.583 | 0.721 |
| Alprazolam | 308 | 70 ^a | 4:43 | 4.333 | 0.812 |
| Ondansetron | 293 | 74 ^c | 8:14 | 8.729 | 0.897 |
| Quinidine | 324 | 90 ^a | 7:19 | 7.583 | 0.883 |
| Lorazepam | 322 | 90 ^a | 7:10 | 7.396 | 0.881 |
| Quinine | 324 | 90 ^a | 7:19 | 7.583 | 0.883 |
| Salmeterol | 415 | 95 ^c | 7:37 | 7.958 | 0.888 |
| R-Temazepam | 300 | 97 ^a | 4:42 | 4.312 | 0.812 |
| S-Temazepam | 300 | 97 ^a | 6:19 | 6.333 | 0.863 |
| Diazepam | 284 | 98 ^a | 7:56 | 8.354 | 0.893 |
| R-Warfarin | 308 | 99 ^a | 15:42 | 18.062 | 0.947 |
| S-Warfarin | 308 | 99 ^a | 20:54 | 24.562 | 0.961 |

Source: Reprinted with permission from Tiller et al., 1995. Copyright 1995 John Wiley & Sons.

^a *Clinical Pharmacokinetics* 15: 254–282 (1988).

^b *Clarke's Isolation and Identification of Drugs*, The Pharmaceutical Press (1986).

^c Data obtained in-house.

also been demonstrated for qualitative analysis. The various MS/MS scan modes of the mass spectrometer (Yost and Boyd, 1990) provide powerful methods of analysis and unique capabilities for information gathering. For example, the product ion scan mode for substructure analysis provides information useful for structure identification, as described earlier for template structure identification strategies. The precursor ion scan mode offers a highly specific approach to screen for targeted component due to the presence of a diagnostic substructure. Carr et al. demonstrated the use of precursor ion experiments to identify N- and O-linked glycoproteins

(Carr et al., 1993). The neutral loss scan mode is used as a class identifier to also screen components that contain a common substructure. Barbuch et al. demonstrated this approach for the class identification of phytoestrogens (Barbuch et al., 1989), using thermospray ionization (TSI)-LC/MS/MS. Brownsill et al. used a similar electrospray ionization (ESI)-LC/MS/MS approach for the analysis of metabolites in rat liver slices (Brownsill et al., 1994).

As new LC/MS-based technology improved the analytical figures of merit (i.e., sensitivity, selectivity, speed, cost-effectiveness), these advantages approached performance benchmarks that are necessary for the routine generation of screening information. The application of LC/MS-based technologies as a screening tool is a powerful strategy for quantitative and qualitative structure analysis.

INTEGRATION

Integration strategies often encompass separate events that involve instrumentation, methodology, and process. When viewed as integrated stages of analysis, similar to the examples described by Cooks and Busch (Cooks and Busch, 1982), increased selectivity is attained. For example, LC/MS/MS represents the integration of three powerful instruments: the HPLC and two mass spectrometers. Retention time information is obtained from the HPLC, and the mass spectrometer provides molecular weight information. A second stage of mass spectrometry yields structure information. The on-line nature of LC/MS/MS provides a high degree of selectivity and an efficient on-line analysis. In addition, integration affords unique opportunities for new experiments.

Traditional methods of pharmaceutical analysis involve a series of multiple steps. For example, the identification of natural products traditionally involves the scale-up of fermentation broths, solvent extraction, liquid/liquid or column fractionation, chromatographic fraction collection, and spectroscopic analysis (usually NMR) of the individual components. Figure 5.2 illustrates the integration of these bench-scale steps into a dedicated LC/MS/MS system (Lee et al., 1997). Integration provides unique and powerful advantages for the on-line identification of natural products (Kerns et al., 1994; Ackermann et al., 1996a). Experiments that once required 2 weeks to perform with traditional approaches are now performed in half a

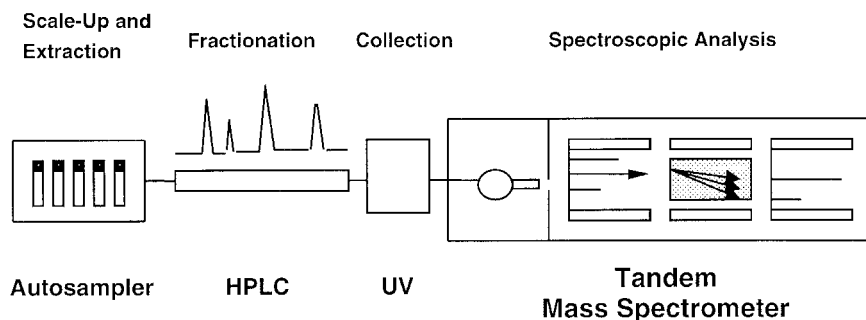

Figure 5.2 The integration of high-performance liquid chromatography and two mass spectrometers to form the LC/MS/MS instrument. The integrated bench-scale steps are shown at the top. (Courtesy of Milestone Development Services, Newtown, Pa., USA.)

day with LC/MS/MS (Gilbert and Lewer, 1998). Similar LC/MS integration approaches are described for bioaffinity-based screening applications (Davis et al., 1999) and automated sample preparation for *in vivo* pharmacokinetics screening (Beaudry et al., 1998). Multidimensional approaches for protein characterization highlight the important features of integration (Anderegg et al., 1997; Washburn et al., 2001). Multidimensional applications that feature LC/MS instrumentation are also used to integrate sample preparation for on-line extraction via column switching (i.e., LC/LC) with quantitative bioanalysis (Needham et al., 1998) and detailed structure analysis of metabolites that use MSⁿ approaches on an ion trap mass spectrometer (Lopez et al., 1998).

Often, integration strategies involve the addition of a step into an existing analysis protocol, which at first would seem less efficient. However, the additional step is strategically placed to provide significant benefits in productivity. For example, the assessment of metabolic stability for large numbers of drug candidates during the drug discovery stage (Ackermann et al., 1998; Korfmacher et al., 2001) incorporates an additional step, but provides unique and timely information. This additional step results in better decisions on which lead compounds to reject, optimize, or select for further development. This qualitative process change results in faster lead optimization. In the same manner, the creation of structure databases for lead candidates in the early preclinical development stage (Rourick et al., 1996) provides a faster approach for the identifica-

tion of impurities, degradants, and metabolites during preclinical development, clinical development, and manufacturing stages.

MINIATURIZATION

As accelerated drug development approaches become more widespread, there is recognition that a single qualitative process change can have a pronounced effect in reducing the size or scale of analysis. Traditional protocols operate at the milliliter to liter volumes and micromole to millimole quantities. As analysis systems have become more sensitive and techniques for manipulating small volumes of liquid samples have become more reliable, experimental procedures have emerged that use smaller amounts of sample. The same is true from the opposite perspective, indicating that smaller sample sizes have resulted in miniaturized systems and formats for analysis. As a result, it is less time-consuming and less expensive to generate smaller sample sizes. Thus, analysis protocols that feature nanoliter to microliter volumes and picomole to nanomole quantities emerged.

One example of a miniaturized LC/MS strategy is the use of 96-well sample plates (Kaye et al., 1996) for extraction. This sample extraction procedure combines batch sample processing within a miniaturized format. Increased sensitivity and decreased volume advances have fostered a new wave of scale-down models. Experiments that were formerly performed at the bench are, instead, performed at the microliter scale in the batch mode. For example, synthetic process research was traditionally performed manually with apparatus at the milliliter level. This approach involves the testing of a range of synthetic conditions for optimum yield and minimum impurity production. Now, process research conditions are tested in microliter levels to produce information on purity and structure (Rourick et al., 1996). This strategy requires fewer reagents and accelerates the evaluation of a wider range of conditions in a shorter time. Another example includes the direct analysis of samples from cell culture experiments (Kerns et al., 1997).

Instrumental developments facilitate the miniaturization opportunity. Advances in chromatography led to the use of capillary HPLC techniques (Liu et al., 1993; Kassel et al., 1994; Arnott et al., 1995) for the powerful separations of increasingly smaller samples. For mass spectrometry, developments with the LC/MS interface that resulted in increased ion transmission and ion sampling helped to

provide improved sensitivity. The development of micro- and nano-spray electrospray sources allows the production of intense ion current from nanoliter flows (Emmett and Caprioli, 1994; Andren et al., 1995; Wilm and Mann, 1996; Davis and Lee, 1998).

PARALLEL PROCESSING

Analysis methods often involve a sequential strategy in which individual compounds are analyzed either separately or in series. The data are evaluated, and the results are compared. This serial analysis approach consistently generates useful information for drug development. However, when a single analysis step is rate limiting to the overall efficiency of the method, parallel processing strategies are employed. Once identified, the rate-limiting step is removed from the on-line approach and performed in a batch-processing mode off-line. As the task is completed, the samples are reintroduced to the analysis procedure. Studies performed by Pleasance and co-workers (Allanson et al., 1996) and Wu and co-workers (Simpson et al., 1998) illustrate a highly effective parallel processing approach, using solid-phase extraction (SPE) techniques. This strategy for analysis is analogous to parallel-compound synthesis approaches for high volume lead optimization (Selway and Terrett, 1996).

Alternatively, drug candidates may be combined for coanalysis in the same sample. Although this combinatorial analysis approach may have previously resulted in impossible analysis complexity, the capabilities of LC/MS and LC/MS/MS for providing detailed information from highly complex samples are an excellent fit with combinatorial parallel processing.

An example of parallel processing using a combinatorial approach involves lipophilicity screening of a series of synthetic analogs (Lee and Kerns, 1998). Lipophilicity, as indicated by retention behavior (k') on an octadecylsilane (C18) bonded phase HPLC column, is often used as a predictor of pharmaceutical characteristics such as membrane transport and protein binding. In the past, k' studies have been conducted sequentially, using a 60 min isocratic LC/UV method; thus, 10 compounds would require 10 h for analysis. A comparable parallel experiment would be to mix all 10 compounds into a single combinatorial mixture and analyze them in a single 1 h analysis with LC/MS. The mass spectrometer is able to distinguish the

compounds according to their molecular weight. Thus, LC/MS reduces the qualitative process enhancement from 10h to 1h.

Similar applications (Volk et al., 1996) combine parallel processing strategies with binary screening (i.e., yes/no results) to rapidly analyze combined mixtures of drug candidates. In these studies, the combinatorial mixture is exposed to a chemical, physical, or physiological environment *in vitro*, and the resulting degradants/metabolites are identified and quantitated with LC/MS and LC/MS/MS techniques (Figure 5.3).

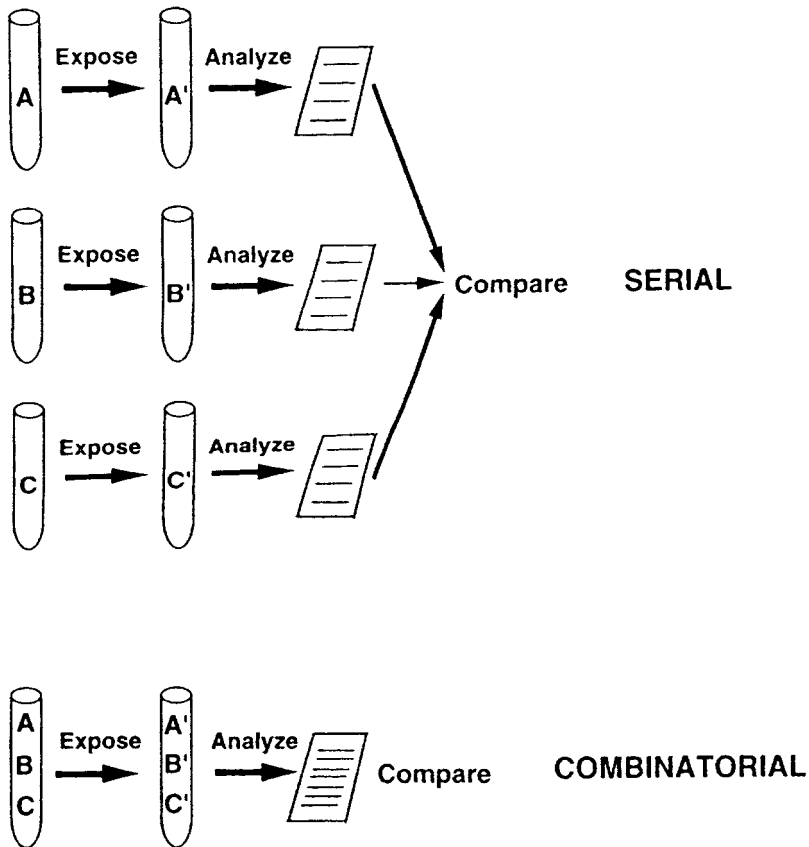

Figure 5.3 The analysis of three compounds with a serial strategy and a parallel combinatorial analysis strategy. (Reprinted with permission from Volk et al., 1996. Copyright 1997 Elsevier.)

VISUALIZATION

The rapid growth in LC/MS productivity resulted in the production of massive amounts of data. Thus, with the increased productivity experienced with modern analysis systems, the bottleneck quickly shifted to data interpretation and management. Approaches that feature the visualization of data help to provide meaningful information for decision making.

One simple example of a visualization tool is the extracted ion current profile (EICP) or mass chromatogram. These plots provide meaningful information from complex LC/MS data, such as the EICP for the protonated molecule ion of the drug candidate during quantitative bioanalysis experiments. Also, methods for the rapid assessment of drug metabolites often include the plotting of EICPs that represent common metabolic transformations, such as $[MH+16]^+$, which corresponds to monohydroxyl metabolite structures. Unique partnerships have developed with software tools responsible for sample tracking, interpretation, and data storage (Julian et al., 1998; Williams et al., 2001). Current LC/MS applications are highly dependent on software to integrate key analysis elements that deal with sample preparation, real-time analysis decisions, databasing, distribution of results, and prediction of fragmentation. Visualization of the data and results is an enabling feature for LC/MS analysis and allows researchers to interpret spectra and correlate/search substructures (Figure 5.4).

Other approaches for presenting information to facilitate the visualization of meaningful patterns for rapid decision involve combinatorial chemistry-related applications. For example, methods for the analysis of combinatorial chemistry-derived samples provide visual representations of the 96-well plate (Figure 5.5) (Yates et al., 2001). Following the LC/MS analysis, an automated analysis is performed, according to preestablished thresholds to search for the protonated molecule ion of the analyte. If the ion is found, then the visual representation of the corresponding well is marked with a distinguishing color scheme. In this way, the scientist quickly inspects the visual representation to make decisions.

Diagrams provide another form of visualization that rapidly communicates pharmaceutical properties of a drug candidate. For example, the labile sites of a molecule can be diagrammed in simple format superimposed on the structure (Figure 5.6) to rapidly communicate the labile sites or soft spots of the candidate structure (Lee

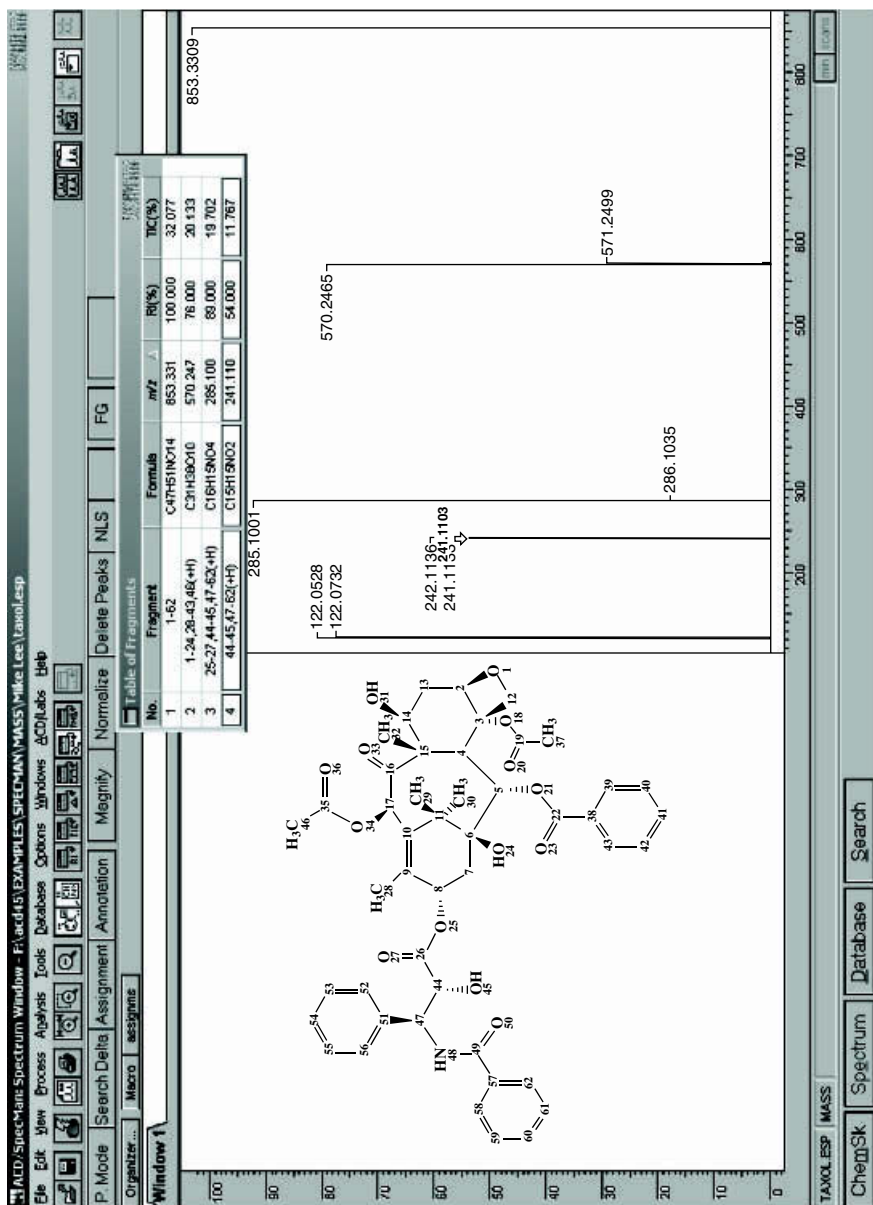

Figure 5.4 Visualization of molecular fragments using a “lasso tool.” The lasso tool is used to identify a particular fragment, and if a signal corresponding to its mass is present in the spectrum, the fragment is highlighted and the corresponding assignment is added to an assignment table. (Courtesy of Advanced Chemistry Development, Toronto, Ontario, Canada.)

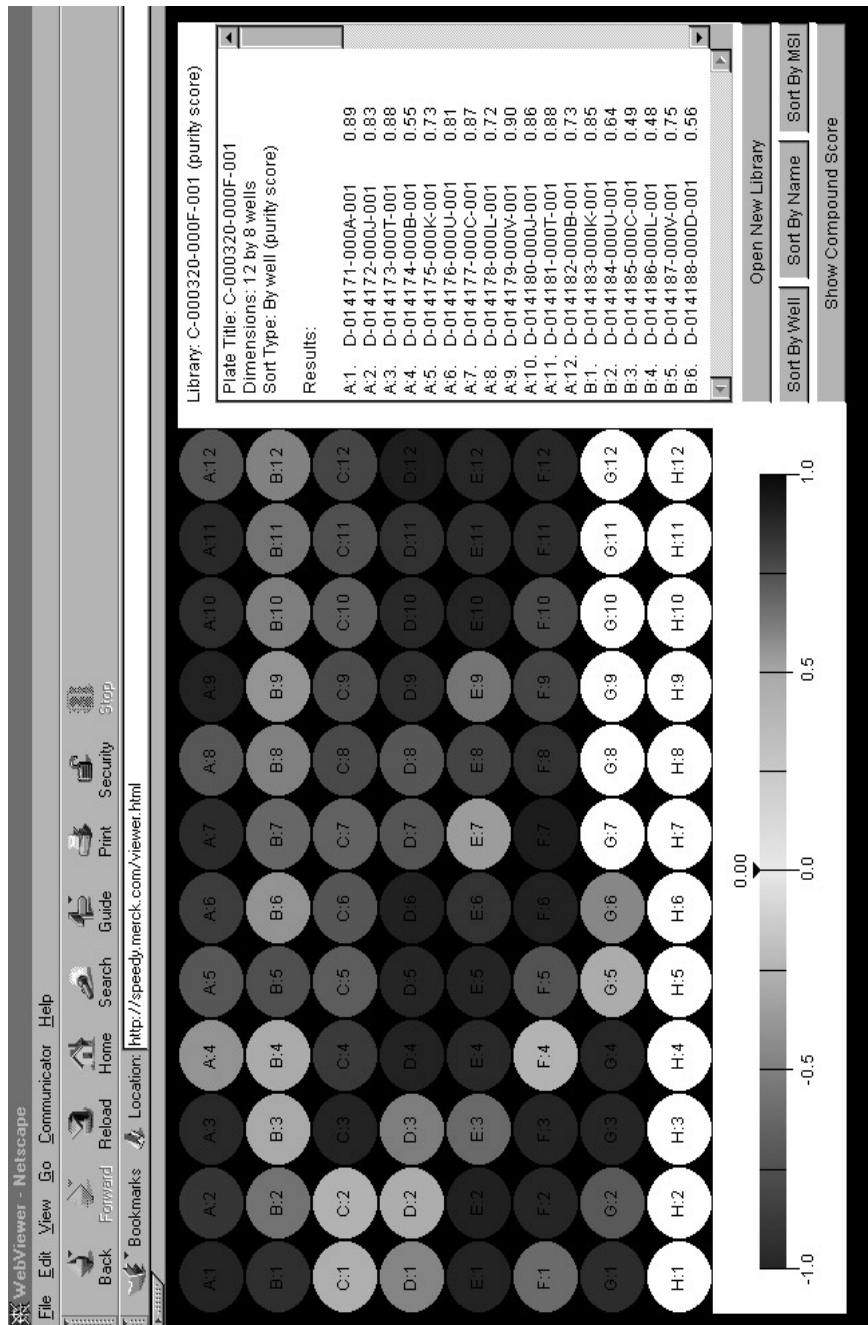

Figure 5.5 Visual representation of the results obtained from LC/MS analysis of a combinatorial chemistry library from a 96-well plate. Visualization of the information allows for rapid inspection of data. (Reprinted with permission from Yates et al., 2001. Copyright 2001 American Chemical Society.)

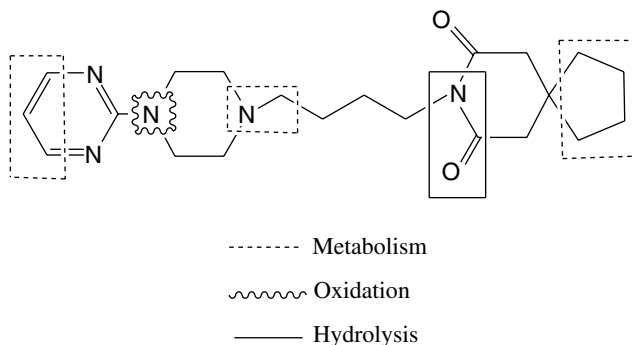

Figure 5.6 Structure of buspirone with areas susceptible to metabolic or chemical degradation highlighted for rapid visualization of the soft spots of the structure. (Courtesy of Milestone Development Services, Newtown, Pa., USA.)

and Kerns, 1998). This information can facilitate decisions for the further optimization of the candidate structure series and can result in molecules with superior pharmaceutical properties.

AUTOMATION

Many examples exist for the integration of robotic mechanisms with analysis instruments. Automation is quite successful for sample preparation stages, such as SPE applications for pharmacokinetic studies and for the queuing of samples for instrument analysis. In many cases, significant savings are realized in human labor expense and the reduction of routine operations. Furthermore, consistent robotic operations afford increased precision via reproducibility of operations from sample to sample compared to manual operations.

Often, the robotic process takes longer than the manual process; however, significant savings and acceleration of the process is realized by overnight or around-the-clock operation. In these cases, the routine operations can be performed by the automated system, leaving the highly trained scientist to perform the more detailed aspects of the analysis that require experience and real-time decisions. Clearly, standard methods provide a necessary step toward the implementation of automated methods via their focus on routine process steps. The automated approach is implemented and validated by careful inspection and observation of performance.

Typically, automated procedures are locked in after they are performed manually. This approach allows for the application of validation procedures to ensure adherence to the desired performance specifications.

Automation provides significant support for those quantitative process approaches aimed at accelerating drug development. Automated analysis strategies are invaluable tools for keeping pace with automated sample generation methods. With automation, the opportunity exists to incorporate qualitative process changes for accelerated development. For example, automated approaches that feature standard methods, databases, and screening are locked in early in drug development; that automation sets the stage for qualitative process changes to facilitate structure identification and the visualization of data. It is important to note that significant benefits are obtained from simple and widely available automation systems. For example, the HPLC autosampler is widely applied for tremendous advantages with LC/MS analysis. This system provides consistent operations, the queuing of large numbers of samples, unattended operation, and integration with analysis.

Automated LC/MS techniques produce a wealth of data. The subsequent interpretation of data provides unique insight for decision. When LC/MS data are accumulated in a matrix format, separation is indexed by time and structural information is indexed by mass. Thus, the task of interpretation becomes systematic and relatively simple. The key for advances in automated interpretation appears to lie in the development of algorithms that embody the rules for discerning patterns and making reliable assignments, typically performed by highly trained analysts. Translation of these rules into software allows these benefits to be transferred to a wider group of LC/MS users via automated search routines as described for database strategies and for real-time decision during the analysis.

Data-dependent software programs allow real-time decisions to be made during an analysis. This approach features a preestablished threshold for the detection of a peak during full-scan mass spectrometry and MS/MS scan modes. If a peak of interest is detected in real-time, then the mass spectrometer is switched from full-scan mode to another scan mode to obtain more information from the same analysis. For example, the system may be automatically switched to the production mode during the analysis of a chromatographic peak to obtain substructural information. Thus, more detailed information is obtained in fewer analyses. This powerful

feature was demonstrated for the identification of leachables during the manufacturing stage of drug development (Tiller et al., 1997a).

Analysis strategies that feature automation significantly impact daily routines in the laboratory. For real-time analysis, this approach is referred to as *in-process* analyses. Open-access analysis strategies make a highly effective approach for maintaining adequate support for high volume sample-generating activities such as medicinal and combinatorial chemistry. Another approach features a batch mode of analysis. A 24-hour analysis is strategically viewed in three parts: morning, afternoon, and evening. The morning hours are used to review results and communicate with collaborators; meaning is derived and new experiments are devised. Afternoons are spent developing and setting up the actual experiment. Evenings are dedicated to high-volume analysis, using automated features for sample preparation, analysis, data reduction, and reporting. This iterative cycle maximizes the use of automation for highly efficient analysis schemes (evening) while creating optimum approaches for collaboration and method development (day).

SUMMARY

The diverse applications of LC/MS in the pharmaceutical industry led to the development of novel strategies and new methods for analysis. The nine analysis strategies described are consistently used throughout the drug development cycle. Many applications focus on structure characterization activities for the quick confirmation of synthesis products and for the identification (quantitative and qualitative) of drugs and related compounds that are contained in complex mixtures such as metabolites in physiological fluids. Applications of LC/MS-based techniques in the pharmaceutical industry highlight the need for novel analysis strategies to keep pace with sample generation and provide unique information.

It is important to emphasize the importance of chromatography for separating biological interferents from analytes of interest (Snyder and Kirkland, 1979). The valuable role for on-line purification and separation in conjunction with mass spectrometry was recognized early by Johnson and Yost (1985) and Henion and Covey (1986), and are still emphasized in the LC/MS methods used today. Many of these important chromatography features are described in Chapter 6.

Interestingly, many of the current LC/MS approaches for pharmaceutical analysis are extensions of gas chromatography/mass spectrometry (GC/MS) (Foltz, 1978), mass spectrometry (Garland and Powell, 1981), and MS/MS (McLafferty, 1983)-based methods. With the introduction and widespread use of LC/MS-based methods, these fundamental approaches for quantitative and qualitative structure analysis became more routinely applicable to a wider scope of pharmaceuticals.

CHAPTER 6

LC/MS APPLICATIONS

The LC/MS applications described in this chapter are organized into the respective drug development stages: drug discovery, preclinical development, clinical development, and manufacturing (Figure 6.1). A sequential illustration of pharmaceutical analysis activities provides a unique perspective on the contributions of LC/MS techniques in drug development. The specific selected examples help to illustrate the successful incorporation of LC/MS-based analysis strategies in the pharmaceutical industry and to highlight their impact on accelerated drug development. Thus, the literature references highlight the application and strategic impact of LC/MS on drug development and are not intended to be comprehensive. Specific reviews that deal with sample preparation (Henion et al., 1998), ionization (Bruins 1994; Bruins, 1998), mass spectrometry (Burlingame et al., 1998), LC/MS instrumentation (Niessen, 1998), MS/MS scan modes (Yost and Boyd, 1990), the application of mass spectrometry techniques in the biological sciences (Burlingame and Carr, 1996; Gross and Pramanik, 2001) and pharmaceuticals (Gilpin and Pachla, 2001) provide in-depth information.

DRUG DISCOVERY

A significant shift in the focus of drug discovery activities has been made from a detailed knowledge-gathering science to incorporate

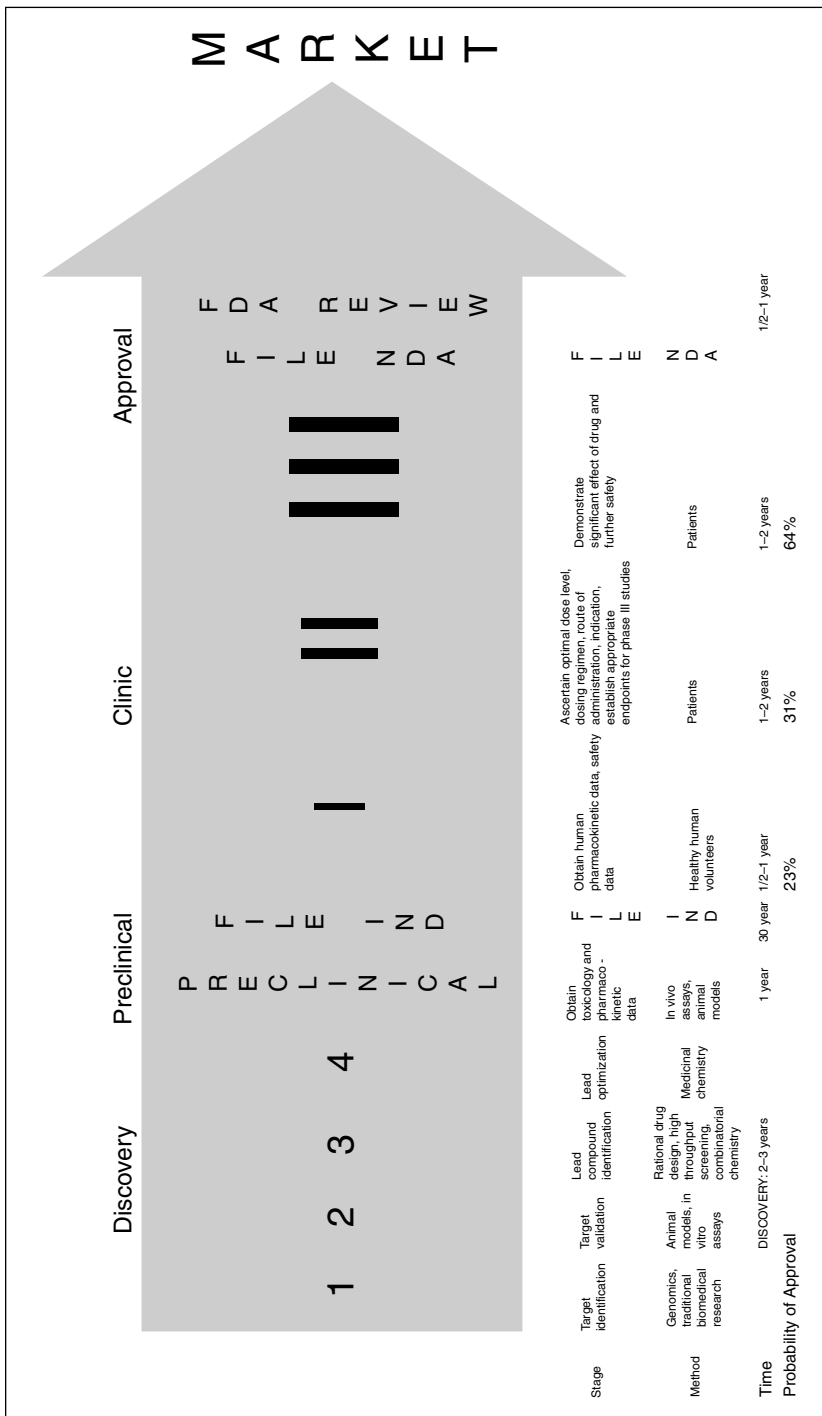

Figure 6.1 The stages of drug development and associated pharmaceutical analysis activities. (Courtesy of SG Cowen, New York, N.Y., USA.)

high-volume events. Approaches that emphasize detail still remain as a critical element of drug discovery; however, they have been overwhelmed by a vast array of screening events aimed at identifying target and lead compounds. As a result, drug discovery researchers are becoming increasingly more dependent on technologies that enhance their ability to quickly generate, test, and validate a discovery.

Analysis Requirements. Due to the use of high-volume approaches to discover new lead compounds, requirements for analysis focus on sensitive, high throughput, and robust methods. These analysis methods provide an excellent complement to rapid sample-generating methods. The functional requirement is to provide analysis information that keeps up with the rate of sample generation. In this way, the timely evaluation is made of chemical and biological parameters that influence decisions for lead candidate selection. This stage of drug development is made extremely challenging by the performance required on a diverse range of compounds.

Analysis Perspectives. The drug development cycle is initiated by activities that deal with the discovery of new medicinal lead structures. Historically, these structures have originated from the isolation of natural products from microbiological fermentation, plant extracts, and animal sources. Other discoveries can be traced to the screening of the vast compound libraries contained in pharmaceutical and chemical companies. The application of mechanism-based, structure-based approaches to rational drug design (Hirschman, 1991; Patchett, 1993; Terrett et al., 1996) and screening approaches (Dower and Fodor, 1991; Moos et al., 1993; Lam 1997) led to three distinct activities that impact pharmaceutical analysis: (1) target identification, (2) lead identification, and (3) lead optimization. These activities have been the primary responsibility of drug discovery with the goal of identifying a novel lead candidate for pre-clinical development.

LC/MS Contributions. The use of LC/MS-based approaches has expanded rapidly in drug discovery during the past several years. Applications that range from the quick molecular weight confirmation of synthetic lead compounds (Taylor et al., 1995; Pullen et al., 1995) to novel and highly selective methods for structure identification (Carr et al., 1993) have been demonstrated. Analysis strategies

typically emphasize rapid turnaround of results with applicability to a wide range of compounds with diverse chemical properties. This emphasis generated unique demands and criteria for performance associated with the LC/MS analysis, namely, sample preparation and data management. As a result, LC/MS applications in the drug discovery stage use highly automated methods, many of which feature the integration of sample generation and analysis activities.

Overview. In this phase of drug development, specific drug discovery applications that deal with proteomics, glycoprotein mapping, natural products dereplication, bioaffinity screening, open-access combinatorial chemistry/medicinal chemistry support, pharmacokinetic screening, and metabolic stability are described (Table 6.1). The features of each LC/MS-based analysis are highlighted with regard for the unique generation of information and the contributions to accelerated drug development. A significant area of growth in drug discovery-related activities has involved the analysis of proteins. Activities that deal with protein analysis and the correlation of protein function are referred to as proteomics. MS-based advances in the fast-evolving field of protein analysis are highlighted in reviews by Haynes and Yates (2000), Blackstock (2000), Pandey and Mann (2000), and Kelleher (2000). These reviews provide excellent background information, technical perspectives, and emerging trends. Other useful references provide current perspectives on the role of mass spectrometry in drug discovery (Pramanik et al., 1999; Poon et al., 1999; Cox et al., 1999; Unger, 1999) and combinatorial chemistry (Süßmuth and Jung, 1999; Swali et al., 1999; Enjalbal et al., 2000).

Proteomics

Protein analysis represents a significant challenge in the pharmaceutical industry. The identification of proteins is essential for understanding biological process and protein function during native and disease states. The resulting insights lead to the development of therapies for intervention and, ultimately, the cure of disease. The information and knowledge derived from this study are extremely valuable for activities involved with target identification during drug discovery. Integration of proteomics-derived information with current protocols for drug development represents a significant challenge. Mass spectrometry-based formats and industry preferences

TABLE 6.1 Representative applications of LC/MS in drug discovery

| Drug Discovery Activity | Analysis | LC/MS Application | Selected References |
|-------------------------|---|---|---|
| Target identification | Protein identification Glycoprotein identification | Peptide mapping Glycoprotein mapping | Arnott et al., 1996 Carr et al., 1993 Liu et al., 1996 Ackerman et al., 1996a |
| Lead identification | Natural products identification Screening | Natural products dereplication Bioaffinity screening | Davis et al., 1999 Blom et al., 1998; Lane and Pipe, 1999 |
| Lead optimization | Combinatorial/medicinal chemistry support | Combinatorial libraries Open access Purification Combinatorial mixtures Combinatorial libraries- quality control | Taylor et al., 1995 Pullen et al., 1995 Zeng and Kassel, 1998; Zeng et al., 1998 Richmond et al., 1999; Yates et al., 2001 Dunayevskiy et al., 1995; Fang et al., 1998; Fitch 1998–1999; Hsu et al., 1999; Duléry et al., 1999; Ventura et al., 2000; Shah et al., 2000 Olah et al., 1997; Allen et al., 1998; Beaudry et al., 1998; Korfmacher et al., 2001 Ackerman et al., 1998 Caldwell et al., 1998; Bu et al., 2000 Ayrton et al., 1998a Lopez et al., 1998 |
| | In vivo drug screening | Pharmacokinetics | |
| | In vitro drug screening | Metabolic stability Membrane permeability Drug–drug interaction Automated metabolite identification | |

are still evolving. Proteomics applications that involve LC/MS are at similar stages of growth as drug metabolism applications during the late 1980s and early 1990s. To date, the predominant application involves the qualitative analysis of proteins via automated database searching (i.e., protein expression profiling). Sensitive and accurate mass spectrometry approaches for quantitation of proteins appear to be destined for major advances.

Protein Expression Profiling Two-dimensional gel electrophoresis (2-DGE) is a primary analysis tool used in the pharmaceutical industry to characterize the expression of proteins. Large numbers of proteins, mostly protein variants, are identified with these methods, and highly expressed proteins are easily located. The resulting differences in protein expression due to treatment with various stimulating factors are the basis for comparative 2-DGE maps (Celis, 1991). In the first dimension of 2-DGE, protein samples are separated according to charge via isoelectric point (pI) using isoelectric focusing. This stage is followed by a separation based on size or molecular weight (MW) using sodium dodecyl sulphate-polyacrylamide gel electrophoresis (SDS-PAGE). Traditional approaches for protein identification of 2-DGE spots use automated Edman degradation, amino acid analysis, and immunostaining techniques.

Mass spectrometry-based methods became an important partner with 2-DGE for correlating proteins to their function (Yates, 1998a). Identification schemes that involve the coordinated use of matrix-assisted laser desorption/ionization-time-of-flight (MALDI-TOF) and LC/MS techniques have made significant contributions to understanding a broad range of events that involve proteins such as covalent modification, proteolytic cleavage, and binding. The 2-DGE is used to provide a 2-D array or maps that contain thousands of expressed proteins. For example, these maps can be used to differentiate the proteomes generated from normal and disease samples. Approaches for identifying proteins separated by 2-DGE use methodologies to cut spots from gels, proteolytically digest the spots, and extract the peptides (Jensen et al., 1999). Typically, MALDI-TOF formats are used to provide a preliminary profile of peptide masses. This profile is compared with a theoretical profile calculated from known sequences contained in a protein database. MALDI-TOF approaches have been effective as a rapid, high-throughput method for analysis of relatively clean 2-DGE spots.

Mixtures of principal components in the presence of several minor components are common with spot sampling from 2-DGE gels. Since

MALDI-TOF provides limited capabilities for mixture analysis, LC/MS methods are used to provide more detailed interrogation of protein expression and peptide sequence. The use of LC/MS approaches for protein identification in conjunction with 2-DGE offers distinct advantages such as the ability to handle low picomole (miniaturized) level samples, enhanced separation, detection, the amenability to N-terminally blocked proteins, and fast analysis. The LC/MS methods for protein characterization focus on four distinct goals: (1) confirmation of putative sequence, (2) identification of amino acid modifications, (3) identification of known proteins, and (4) sequence determination of unknown proteins.

Arnott and colleagues described an electrospray ionization (ESI)-LC/MS-based approach where the proteins from normal neonatal rat cardiac myocytes are electroblotted to a membrane and identified by staining (Arnott et al., 1995). Protein spots are cut from the blot, destained, reduced, alkylated, and digested with endoproteinase Lys-C (Henzel et al., 1993). Small diameter, packed capillary HPLC columns (<100 μm) are used to enhance performance by minimizing sample handling and maximizing sensitivity (Moseley et al., 1991; Kassel et al., 1994). The resulting capillary LC/MS and LC/MS/MS experiments performed on a triple quadrupole mass spectrometer are used to determine the identities of each protein in combination with a database searching routine. In the Arnott study, the differences in protein expression levels between normal and enlarged (hypertrophic) heart cells were profiled as part of a study to determine factors involved with congestive heart failure.

The capillary HPLC separation from a selected protein spot provides a base-peak profile shown in Figure 6.2A. The base-peak profile is similar to a total ion current (TIC) profile, but it contains only the most abundant mass spectral peak in each scan. The chromatogram is simplified and the contributions from background ion abundances are eliminated, resulting in an enhanced signal-to-ion ratio for an improved visualization of data. The molecular mass for each component is labeled along with corresponding amino acid residues. This format provides a comprehensive approach for peak selection and peptide identification.

Figure 6.2B shows the mass spectrum of the second major chromatographic peak (residue 60–70 peptide), which contains the triply charged (m/z 451.3) and doubly charged (676.7) molecular ions. Thus, a molecular weight of 1351 is assigned. The next step involves the selection of either one of the molecular ions (m/z 451.3, 676.7) to obtain amino acid sequence information by using MS/MS. The

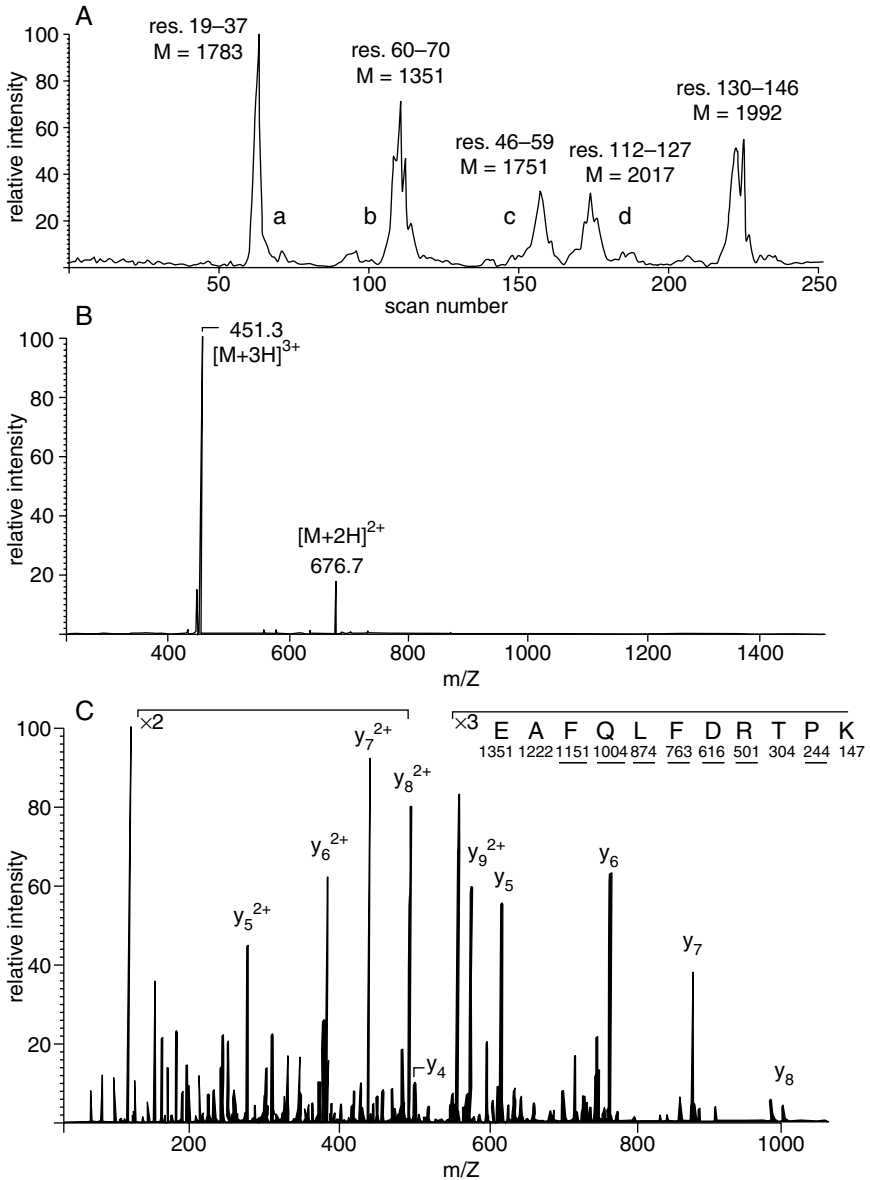

Figure 6.2 Identification of proteins separated by 2-DGE. (A) Base-peak profile from the capillary HPLC separation from a selected protein spot. (B) Mass spectrum of the second major chromatographic peak (residue 60-70). (C) LC/MS/MS product ion spectrum of m/z 451.3. (Reprinted with permission from Arnott et al., 1995. Copyright 1995 American Chemical Society.)

resulting product ion spectrum of m/z 451.3 is shown in Figure 6.2C. This analysis features a reduced resolution on both mass analyzers (Q1 and Q3) to obtain maximum sensitivity. The corresponding amino acid residues are assigned by using a template structure identification approach on the basis of mass differences between peaks. The partial sequence FQ[LL]F is determined directly from the product ion spectrum and entered into an in-house database searching program, FRAGFIT. Because leucine and isoleucine cannot be distinguished with low-energy collisions in a triple quadrupole mass spectrometer, FQIF and FQLF were both searched. The protein that corresponds to myosin light chain was matched by using this partial sequence information, peptide masses, and search parameters (Table 6.2).

The development and use of various protein sequence databases for automated search routines (Eng et al., 1994; Clauser et al., 1999) are an essential component of protein analysis that uses mass spectrometry techniques. These programs (i.e., SEQUEST, MASCOT) require only a few peptides for matching; therefore, the absence of a match for a particular peptide does not affect the search performance. Using protein database searches provides an efficient way of confirming a putative sequence from corresponding full-scan mass spectrometry and MS/MS data.

The capillary LC/MS-based approach for peptide mapping performed by Arnott and colleagues features miniaturized sample-loading procedures, which are routinely amenable to small quantities of peptides. The reliable characterization of protein/peptide mixtures in conjunction with the widely used 2-DGE methods offers a powerful fingerprinting approach in the pharmaceutical industry. Low femtomole detection limits (typically <50 femtomole) with a mass accuracy of ± 0.5 Da provide unique advantages for protein identification. Liberal parameters for mass range and unmatched masses are used for the initial protein search, whereas more conservative parameters are used to reduce the number of matches and to improve the confidence in the search.

The use of high performance liquid chromatography (HPLC) on-line or off-line is an essential feature for peptide mapping to integrate the removal of buffers and salts (purification) and the separation of analytes (preconcentration) with mass spectrometry. With on-line LC/MS approaches, low flow rates (<100 μ L/min) have been demonstrated to provide maximum sensitivity with ESI techniques for the analysis of proteins. In the work performed by Arnott and

TABLE 6.2 FRAGFIT results for spot 6 from 2-DGE of normal neonatal rat cardiac myocytes, indicating a match with myosin light chain

Data Summary

5 major peaks with $[M + H]^+$ 1783.8, 1352.1, 1751.8, 2017.6, 1992.6

4 smaller peaks with $[M + H]^+$ 2164.1, 1510.1, 3285.1, 3171.1

MS/MS data yields partial sequences for 1352.1 : FQ[I,L]F and 1783.8 : APE

FRAGFIT parameters (chosen for all searches)

Lys-C specificity

Oxidized Met allowed

Partial digestion allowed

One unmatched mass allowed

Carboxymethyl Cys assumed

A. Input: Masses of the 5 major peaks and mass tolerance of ± 0.5 Da.,

Output: 4 database hits:

Myosin light chain 1, slow-twitch muscle b/ventricular isoform (22025.01 Da)

Reticulocyte-binding protein 1, PvRBP-1 = transmembrane-anchored
(325851.41 Da)

Reticulocyte binding protein 1 precursor-Plasmodium vivax (330217.5 Da)

Titin-rabbit (fragment) (751113.32 Da)

[4 specified mol wts matched. not found: 2017.60]

B. Input: Masses of all peaks, mass tolerance of ± 0.5 Da, and partial sequences,

Output: 1 database hit:

Myosin light chain 1, slow-twitch muscle b/ventricular isoform (22025.01 Da)

1784.03 0.23 19: AAPAPAAAPAAPEPERPK

1510.68 0.58 48: IEFTPEQIEEFK

1752.02 0.22 46: IKIEFTPEQIEEFK

1352.53 0.43 60: EAFQLFDRTPK

3284.80 0.30 75: ITYGQCGDVLRLALGQNPTQAEVLRVLGKPK

3MO 2017.38 0.22 112: MMDEFTFLPMLQHISK

1992.15 0.45 130: DTGTYEDFVEGLRVFDK

1MO 3171.51 0.41 147: EGNGTVMGAELRHVLATLGERLTEDEVEK

1MO 2164.37 0.27 176: LMAGQEDSNGCINYEAFVK

C. Input: A single mass plus partial sequence: 1352.1 FQ[I,L]F,

Output: 1 database hit:

Myosin light chain 1, slow-twitch muscle b/ventricular isoform (22025.01 Da)

Source: Reprinted with permission from Arnott et al., 1995. Copyright 1995 American Chemical Society.

colleagues, a precolumn split of the mobile phase ($\sim 200 \mu\text{L}/\text{min}$) was used to obtain a flow rate of $0.2\text{--}0.5 \mu\text{L}/\text{min}$. This microcolumn HPLC method minimizes the column elution volume and maximizes the concentration of peptide that enters the ESI interface of the mass spectrometer (Kennedy and Jorgenson, 1989). Other examples

of low-flow approaches include peak parking techniques, where the solvent flow and gradient are stopped and the sample continues to flow into the mass spectrometer (Davis et al., 1995; Davis and Lee, 1998). This procedure provides longer sampling times and an improved signal-to-noise ratio because the signal can be averaged for a greater length of time.

The ESI-LC/MS-based approaches that feature ion trap (Gatlin et al., 1998; Washburn et al., 2001) and quadrupole time-of-flight (QTOF) (Blackburn and Moseley, 1999) mass spectrometers are routinely used for the identification and characterization of proteins. Nanoelectrospray LC/MS formats (Figure 6.3) are used to provide lower limits of detection and fully automated sample preconcentration and desalting. On-line LC/MS approaches for protein expression profiling are also used with ESI-TOF (Banks and Gulcicek, 1997; Chong et al., 2001) and ESI-Fourier transform (FT) (Kelleher

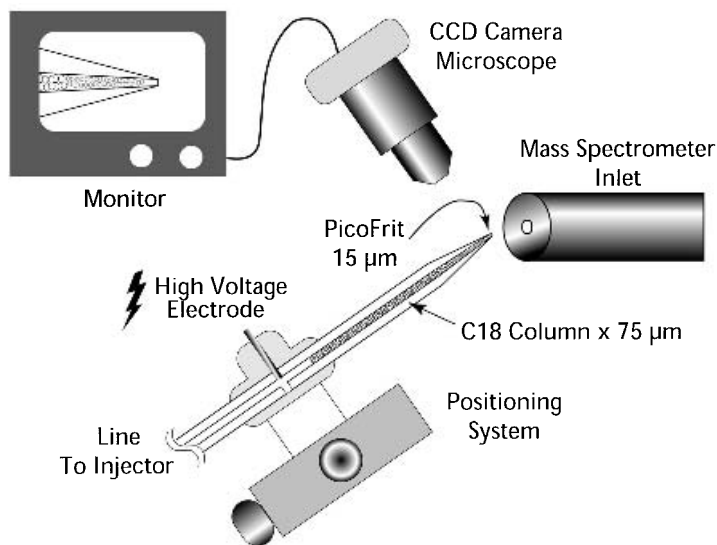

Figure 6.3 Schematic of a nanoscale capillary ESI interface. This specialized LC/MS interface, operating at flow rates from 20–500 nL/min and using 50 to 100 μm ID columns, typically provides low femtomole sensitivity. Fully automated sample handling and preparation procedures (i.e., desalting and preconcentration) combined with specialized devices for high separation and variable nL gradient flow rates provide unique capabilities for high-throughput analysis of proteins. (Courtesy of New Objective, Inc., Woburn, Ma., USA.)

et al., 1999; Kelleher, 2000) mass spectrometers. Banks and Gulcicek described the ESI-TOF analysis of peptide mixtures with separations in less than 35 sec, using a nonporous silica support (Banks and Gulcicek, 1997). The resulting chromatographic peak widths are less than 1 sec wide. The unique nature of the TOF mass spectrometry allows for the complete analysis of these narrow peaks. Off-line approaches also feature sample cleanup, preconcentration, and the batch elution of peptides. This off-line feature is commonly used with MALDI-TOF techniques for the simultaneous analysis of peptide mixtures. Because these methods are decoupled from the actual analysis, highly automated procedures can be used to prepare and manipulate samples (Houthaevae et al., 1995; Stevenson et al., 1998).

The previously described methods for peptide mapping involve the analysis of <3 kDa peptides that result from proteolytic digestion. This bottom-up approach obviates the analysis of the entire primary structure (Kelleher, 2000). With the use of ESI-FTMS formats, top-down strategies for peptide mapping are possible (Kelleher et al., 1999). The ESI-FTMS top-down approach is initiated with direct MS/MS fragmentation of the intact protein rather than a proteolytic digestion. For proteins less than 50 kDa, relatively large protein fragments (5–40 kDa) are generated with fewer protein fragments.

Quantitation Once protein expression profiling activities characterize qualitative features, the attention turns to delineating protein interactions and mechanistic pathways responsible for disease. These studies also require rapid sequence determination/confirmation combined with accurate and sensitive quantitative analysis. The quantitation approaches would allow for direct comparison of protein amounts (absolute or relative) from a variety of cellular states. Because of the reasons stated previously, quantitative applications are likely to be less dependent on 2-DGE and rely primarily on formats that involve specific purification and/or chromatographic separation with mass spectrometry.

The use of isotope-coded affinity tag (ICAT) approaches for identification and quantitation of proteins contained in complex mixtures is a developing methodology that bypasses 2-DGE (Gygi et al., 1999). The ICAT approach is a derivative of an isotope dilution method and involves the introduction of a postgrowth biotin affinity tag onto cysteine residues via iodoacetamide chemistry (Figure 6.4). Proteome samples obtained from two cellular states are labeled: one with the d_0 -ICAT and the other with d_8 -ICAT. The two

Glycoprotein Mapping

Similar analysis strategies are applied for the peptide mapping of glycoproteins (Medzihradzky et al., 1994; Reinhold et al., 1995; Hancock et al., 1996). Carr and co-workers combined in-source collisionally induced dissociation (CID) with LC/MS/MS to identify sites of N- and O-linked glycosylation (Carr et al., 1993). This novel approach uses a series of LC/MS and LC/MS/MS experiments to generate peptide maps and to selectively screen for glycoproteins.

The method is based on the characteristic fragmentation of glycoproteins to form a *N*-acetylhexosamine (HexNAc^+) fragment ion at mass-to-charge ratio (m/z) 204. This fragment ion serves as a diagnostic marker for N- and O-linked glycopeptides. A precursor ion experiment is performed on complex mixtures to detect precursor ions that fragment to produce the m/z 204 (HexNAc^+). The resulting precursor ions correspond to the $[\text{M} + \text{H}]^+$ ions of glycopeptides.

This LC/MS/MS-based strategy for mapping glycoproteins and proteins is shown in Figure 6.5. A mixture of peptides and glycopeptides is generated when the glycoprotein (>75 pmol) is reduced, alkylated, and enzymatically digested. A series of three separate experiments, requiring approximately 25 pmol of digest per experiment, is used to identify the N- and O-linked glycopeptides. The first experiment uses LC/MS to provide a map of the peptide portion of the protein and to indicate the presence of glycopeptides. The second experiment involves the use of LC/MS/MS to screen the mixture for compounds that fragment to yield the diagnostic m/z 204 (HexNAc^+). N- and O-linked glycopeptides are both identified. A final experiment is performed on a sample treated with peptide N:glycosidase F (PNGase F) to release the N-linked oligosaccharides and to identify the O-linked glycopeptides exclusively.

The utility of this procedure was demonstrated on a digest of bovine fetuin, a 42 kDa glycoprotein. The TIC chromatogram and a reconstructed ion current (RIC) trace for m/z 204 from a trypsin/Asp-N digest of bovine fetuin are shown in Figure 6.6A and B, respectively. In this experiment, the orifice voltage is ramped linearly from 120 V to 65 V to enhance the production of the diagnostic m/z 204 (HexNAc^+). The TIC chromatogram, corresponding to the precursor-ion scan of m/z 204 (HexNAc^+), is shown in Figure 6.6C. This TIC trace indicates the presence of at least 12 glycopeptides (N- or O-linked) that generate the m/z 204 product ion. The resulting spectra typically contain multiple charge states that corre-

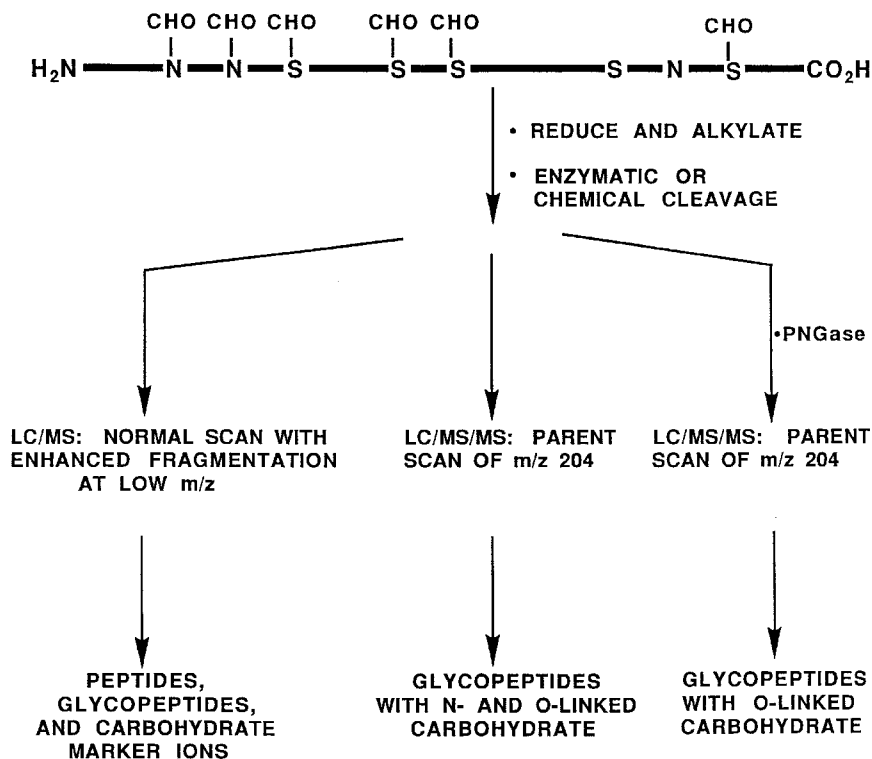

Figure 6.5 LC/MS/MS strategy for mapping glycoproteins and proteins via reduction, alkylation, and enzymatic digestion, followed by three LC/MS and LC/MS/MS experiments. (Reprinted with permission from Carr et al., 1993. Copyright 1993 Cold Spring Harbor Laboratory Press.)

spond to triply and doubly protonated molecules. From the observed masses, the average molecular weight of the glycopeptide is calculated. Further treatment with PNGase F results in the selective removal of N-linked carbohydrates and in the identification of N- or O-linked glycopeptides.

Liu and co-workers described a glycoprotein analysis strategy that features micro-LC/MS techniques for the high-resolution chromatographic separations of complex peptide mixtures (Liu et al., 1993). By digesting biological samples with appropriate enzymes such as trypsin and PNGase F, comparative maps are generated and used for locating glycosylated peptide fragments. This example highlights the application of chromatography to achieve the necessary selectivity for identification by mass spectrometry.

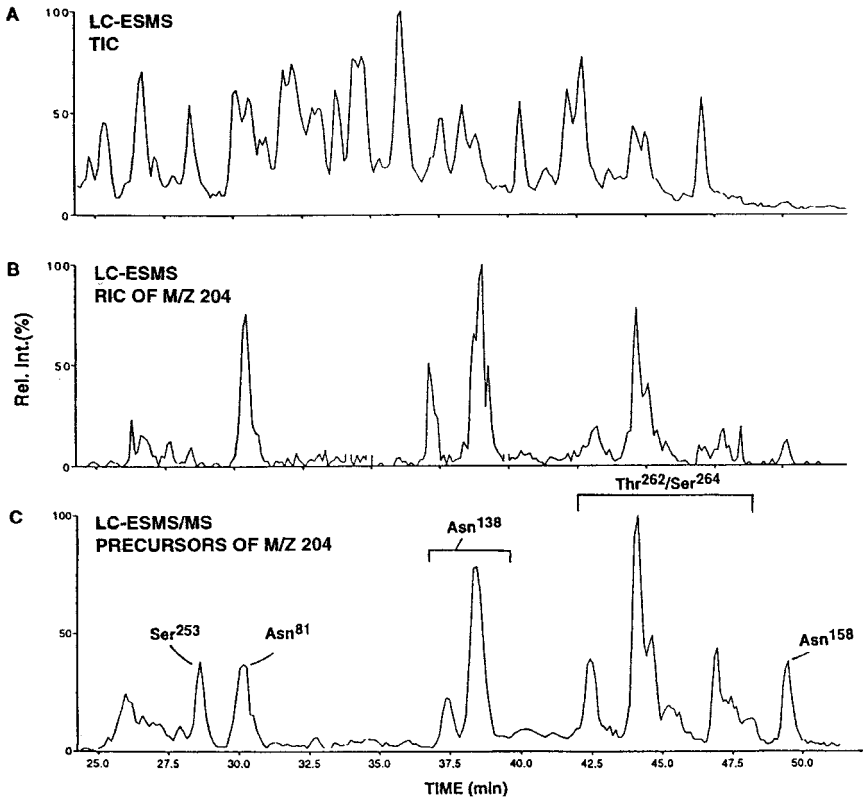

Figure 6.6 Application of the LC/MS/MS strategy for mapping glycoproteins to bovine fetuin (42 kDa). A trypsin/Asp-N digest of bovine fetuin was analyzed using the strategy shown in Figure 6.1. (A) Total ion chromatogram (TIC), scanning m/z 150–2000. (B) Reconstructed ion chromatogram (RIC) from for m/z 204 (HexNAc^+), scanning m/z 150–2000. (C) TIC screening precursors of m/z 204. (Reprinted with permission from Carr et al., 1993. Copyright 1993 Cold Spring Harbor Laboratory Press.)

This procedure for glycoprotein characterization involves the generation of a full-scan mass spectrum of the intact glycoprotein without pretreatment. From this spectrum, a pattern of glycosylation microheterogeneity is determined. Next, a full-scan mass spectrum of the sample is obtained after pretreatment with PNGase F. Most glycosylated peaks disappear, and the molecular mass of the deglycosylated protein is identified.

The possible glycoforms observed from this type of LC/MS experiment performed on bovine ribonuclease B are listed in Table 6.3.

TABLE 6.3 Heterogeneity of ribonuclease B glycoforms observed by electrospray LC/MS analysis

| Native Protein | M_r | PNGase F-Treated Protein | M_r |
|---|--------|---|--------|
| Polypeptide chain | 13,692 | Polypeptide chain | 13,692 |
| Polypeptide adduct (phosphate) | 13,789 | Polypeptide adduct (phosphate) | 13,791 |
| Hex ₅ -(HexNAc) ₂ -polypeptide | 14,908 | HexNAc-polypeptide | 13,895 |
| Hex ₅ -(HexNAc) ₂ -(polypeptide + phosphate adduct) | 15,005 | HexNAc-(polypeptide + phosphate adduct) | 13,993 |
| Hex ₆ -(HexNAc) ₂ -polypeptide | 15,070 | | |
| Hex ₆ -(HexNAc) ₂ -(polypeptide + phosphate adduct) | 15,168 | | |
| Hex ₇ -(HexNAc) ₂ -(polypeptide + phosphate adduct) | 15,326 | | |
| Hex ₈ -(HexNAc) ₂ -(polypeptide + phosphate adduct) | 15,492 | | |

Source: Reprinted with permission from Liu et al., 1993. Copyright 1993 Elsevier.

Diagnostic increments of M_r 162 and M_r 203 are observed, which correspond to hexose and *N*-acetylhexosamine residues, respectively. By comparing peptide maps prior to and after enzymatic cleavage, peptide fragments attached to oligosaccharides may be located and distinguished from nonglycosylated peptides. The comparative map of enzymatic digests obtained for bovine ribonuclease B is shown in Figure 6.7. In this particular case, abundant signals are exhibited and assigned to the majority of expected peptide fragments. The benefit of this comparative mapping scheme is the rapid visual survey of unique peaks indicative of glycosylation. This comparative map indicates a unique broad peak between 16 and 17.5 min. Based on the protocols for enzymatic treatment, this peak is related to the heterogeneity of glycoforms attached to a specific tryptic peptide. The tryptic fragments of bovine ribonuclease B are further reacted with PNGase F and analyzed with LC/MS and LC/MS/MS standard methods to establish the identity and attachment of the carbohydrate substructure. This micro-LC/MS approach provides a valuable method for the rapid microheterogeneity screening of oligosaccharide substructures and the determination of carbohydrate content.

Additional structural analysis of glycoproteins generally requires fragmentation by chemical or enzymatic cleavage and by separation

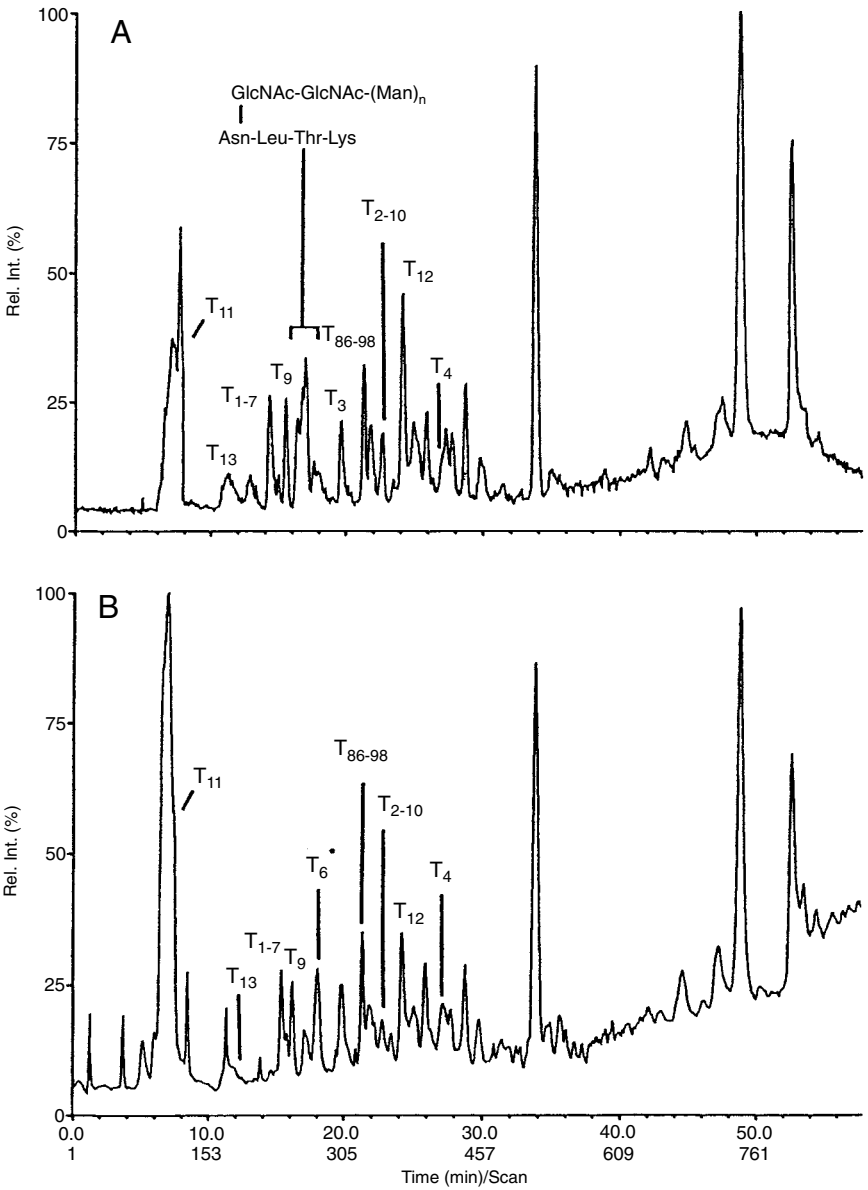

Figure 6.7 Comparative peptide map of enzymatic digests of bovine ribonuclease B. (A) TIC trace of digested RCM-glycoprotein with trypsin. (B) TIC trace of digested RCM-glycoprotein with trypsin and PNGase F. (Reprinted with permission from Liu et al., 1993. Copyright 1993 Elsevier.)

or isolation. On-line LC/MS methods provide an integrated approach for this type of analysis. This approach is consistent with the early analyses of glycoproteins that were described by Covey, Ling, and others (Covey et al., 1991; Ling et al., 1991). Comparative maps of enzyme digests allow for a quick survey of the expected peptide fragments. Various LC/MS schemes may be used to indicate unique peaks related to the heterogeneity of glycoforms attached to a specific tryptic peptide (Reinhold et al., 1995) or to quantitate specific glycoprotein structures (Mazaroff et al., 1997).

Natural Products Dereplication

Natural products offer a source of unique chemical diversity for the pharmaceutical industry. Numerous successful drugs derived from natural products have been introduced for the treatment of cancer (Hung et al., 1996; Pettit et al., 1994), immunosuppression (Perico et al., 1996), cardiovascular therapy (Nadin and Nicolaou, 1996; Tomoda et al., 1994), and antiinfective therapy (Turner and Rodriguez, 1996).

Traditional approaches for natural product screening in drug discovery involve the testing of crude extracts obtained from microbial fermentation broths, plants, or marine organisms. When activity above a certain level is detected, active components are isolated and purified for identification. This process is often time consuming; where the physicochemical characteristics of the active components are determined, known compounds are identified (dereplication), and the novel compounds are scaled-up for more detailed investigation.

Shorter discovery timelines and accelerated development expectations have hindered the traditional approaches for natural products research. Furthermore, emphasis on chemical diversity presents a great challenge in this area, particularly because traditional natural products screening programs focus on one source of chemical diversity such as microorganisms or plants. Still, the primary issue remains: how to assay this ideal source of new, biologically active compounds within the current timeframe necessary for modern drug discovery research. At the heart of this issue is the fact that traditional isolation and scale-up procedures are inefficient and often become the bottleneck in natural products dereplication.

A specific area of drug discovery research, which required an immediate need for highly sensitive and rapid analysis, dealt with

antibiotic-containing mixtures from fermentation broths. The need for rapid dereplication of bioactive compounds derived from natural sources is critical due to the overuse of antibiotics (Georgopapadakou and Walsh, 1994). This overuse has significantly accelerated the rate of pathogen mutation and has resulted in a growing resistance to current drugs (Davies, 1994). Furthermore, there are increasing numbers of immunocompromised patients due to autoimmune deficiency syndrome (AIDS) (Bates, 1995). Thus, novel antibiotic compounds are in high demand.

Most antibiotics come from secondary metabolites of soil microorganisms that inhibit bacteria or fungi. Large-scale screening of microorganism fermentations followed by isolation and structure elucidation is required. Because many natural products have been previously identified, approaches that avoid time-consuming isolation and provide quick elucidation are essential.

To address these needs, a new strategy was introduced by Ackermann and co-workers that featured the use of an on-line ESI-LC/MS approach that integrates multicomponent identification, fraction collection, and sample preparation for bioactivity screening (Ackermann et al., 1996a). Using this LC/MS-based approach, crude extracts are screened without extensive purification and chemical analysis. Less material is required due to the sensitivity of the technique, and chromatographic resolution is retained. This resolution would ordinarily be relatively poor with a fraction collection process. Furthermore, because the ESI acts as a concentration-dependent detector (Hopfgartner et al., 1993), the HPLC effluent can be split between mass spectrometry analysis and fraction collection. Thus, molecular weight information is obtained, and approximately 90% of the fractionated material is recovered for biological testing.

The key to rapid dereplication is dependable molecular weight determination. This information is used with existing natural product databases that contain information regarding bioactive compounds, the physical descriptions of the microorganisms from which they come, their spectrum of activity, the method of extraction and isolation, and physical data (i.e., molecular weight, UV absorption maxima). Molecular weight is the most critical information for initial searches because of its link to structural specificity. This information is used to make pivotal decisions on whether to proceed to more time-consuming isolation steps based on novelty of the compound. In the study described by Ackermann and colleagues (Ackermann

et al., 1996a), LC/MS is used to increase sensitivity and accelerate analysis. These features serve to significantly reduce labor.

The instrumental configuration of the LC/MS system developed by Ackermann and colleagues is shown in Figure 6.8. This system features an HPLC, UV detector, fraction collector, ESI-triple quadrupole, and MALDI mass spectrometers. Filtered fermentation broths are extracted with butanol or ethyl acetate and eluted on a gradient C18 reversed-phase HPLC separation. The eluent is split 1:10 between a quadrupole MS/MS instrument (scanning 250–2000 amu/3sec in the full scan mode) and a single wavelength UV detector (254 or 230 nm). One-minute fractions are collected after the UV detector. Of these fractions, 20–50 μ L is used for MALDI-TOF analysis, and the remainder is concentrated for microbiological testing. The LC/UV chromatogram is compared to the bioactivity assay histogram to highlight the peaks that contain activity. The molecular weights of the active peaks are obtained for novelty assessment of the compounds.

Using this approach for natural products dereplication, data are routinely obtained from 40 μ g of crude extract. Performance examples include the identification of 16 analogs of teicoplanin and 12 analogs of phenelfamycin from separate samples. The summary of results obtained for phenelfamycin is shown in Table 6.4. The correlation of fraction, retention time, and molecular weight provides the essential information for rapid dereplication and identification. The time required to dereplicate natural product samples is about 1 week with this LC/MS-based method compared to several weeks by previous methods that involve traditional isolation steps. The use of this LC/MS-based methodology results in greater clarity and confident decisions for proceeding with the full structural study of an active component derived from a culture.

Similar approaches that use on-line LC/MS and LC/MS/MS techniques have been described for natural products dereplication (Gilbert and Lewer, 1998; Janota and Carter, 1998). In the method described by Gilbert and Lewer, approximately 100,000 natural product extracts are screened annually for *in vivo* and *in vitro* activity, using the system shown in Figure 6.9. The approach for dereplication involves a comparison of retention time, full scan mass spectra (i.e., molecular weight information), and MS/MS spectra with those from known biologically active standards. Thus, previously identified components are rapidly eliminated and do not require

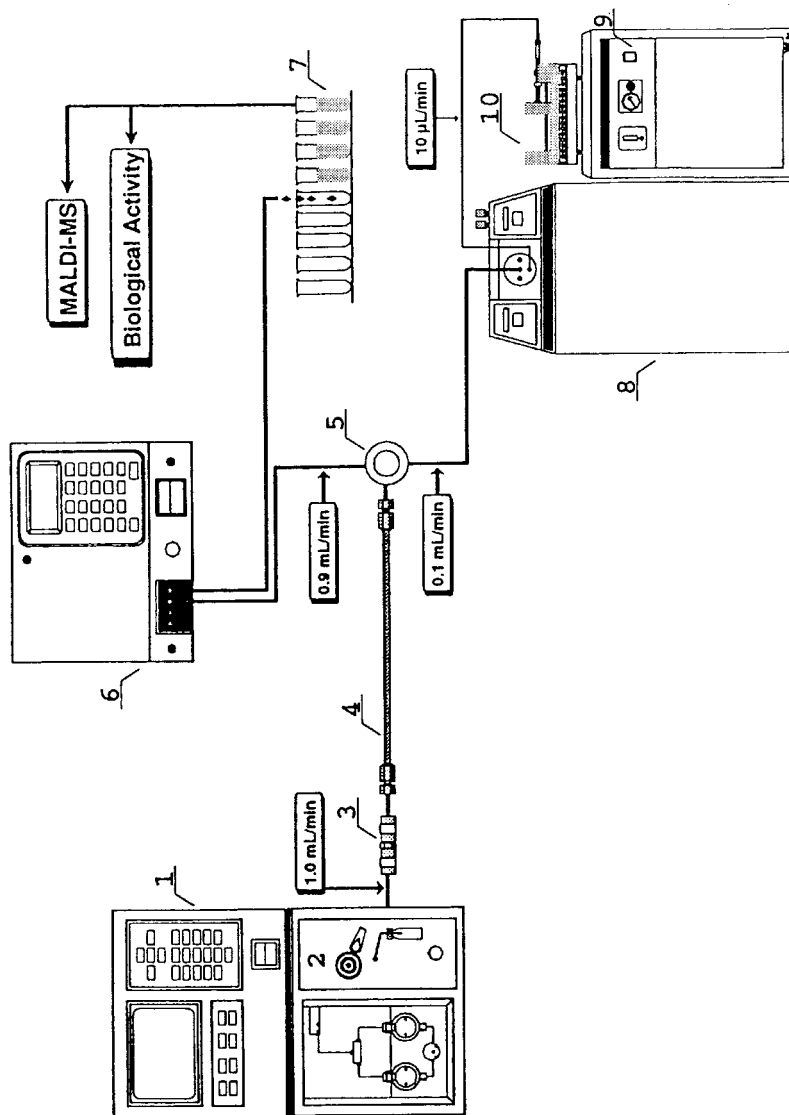

Figure 6.8 Diagram of instrumental configuration of the LC/MS system used for characterization of crude fermentation extracts. The system consists of the following components: (1) HPLC; (2) loop injector; (3) guard column; (4) 5 µm C18 HPLC column (4.6 mm × 25 cm); (5) zero dead volume tee; (6) UV detector; (7) fraction collector; (8) triple quadrupole mass spectrometer equipped with ESI interface; (9) ESI power supply and gas manifold; and (10) syringe pump. (Reprinted with permission from Ackermann et al., 1996a. Copyright 1996 Elsevier.)

TABLE 6.4 Mass spectral LC/MS and MALDI-TOF data summary for the novelty assessment of phenelfamycin sample GE21640 F VI 45

| Active Fraction ^a | Ret. Time (min) | Mol. Wt. monoisotopic | [M + K] ⁺ ESI | [M + K] ⁺ MALDI | Identity ^b | Key Fragment Ions (<i>m/z</i>) |
|------------------------------|-----------------|-----------------------|--------------------------|----------------------------|-----------------------|----------------------------------|
| 8 | 8:40 | 819.4 | 858.2 | n.d. | UN-1 | 626,504 |
| 9 | 9:15 | 963.5 | 1002.4 | n.d. | UN-2 | 626,504 |
| 12 | n.a. | n.a. | n.d. | n.d. | unk | n.a. |
| 13 | 13:45 | 829 | 868.2 | n.d. | unk | n.a. |
| 14 | 14:30 | 973 | 1002.4 | n.d. | unk | n.a. |
| 14 | 14:40 | 937.5 | 976.2 | 976 | A | 744,622 |
| 15 | 15:30 | 1081.6 | 1120.3 | 1121 | C | 744,622 |
| 16 | 16:25 | 1225.6 | 1264.3 | 1263 | E | 744,622 |
| 17 | 17:35 | 937.5 | 976.4 | 976 | B | 744,608 |
| 18 | 18:20 | 1081.6 | 1120.2 | 1121 | D | 744,608 |
| 19 | 19:15 | 1225.6 | 1264.4 | 1263 | F | 744,608 |
| 19 | 19:40 | 927 | 966.3 | n.d. | unk | n.a. |

Source: Reprinted with permission from Ackermann et al., 1996a. Copyright 1996 Elsevier.

Note: n.a. = not applicable; n.d. = not detected; unk = unknown.

^a See histogram in Figure 6.

^b For structural assignments refer to Figure 5.

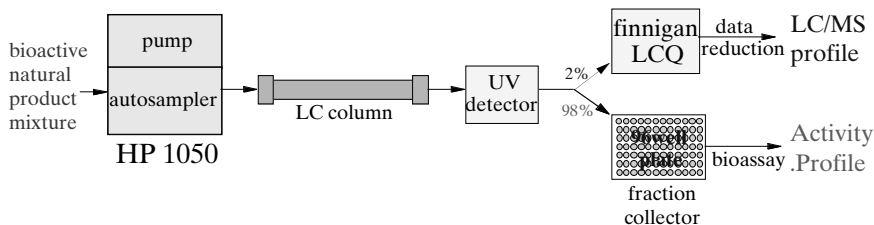

Figure 6.9 Diagram of instrumental configuration of the LC/MS system used for annually screening approximately 100,000 natural product extracts. (Gilbert and Lewer 1998.)

time-consuming structure elucidation studies. This savings of effort allows researchers to focus efforts on novel chemistries. Samples of novel compounds are infused into an ion trap mass spectrometer, and an MS^n fragmentation map is generated. Using this LC/MS-based approach, the structure of homolelobanidine was identified from an extract of *Polygonum flacidum*. The MS^n feature provides unique structure identification capabilities that allow for the facile assignment of neutral losses and characteristic substructures of the molecule.

Lead Identification Screening

Combinatorial chemistry initiatives have created a tremendous challenge for activities that deal with the screening of mixtures (i.e., small molecule compound libraries) for activity against a specified target (Schriemer and Hindsgaul, 1998). The MS-based approaches that use affinity selection (Kaur et al., 1997), encoding methodologies (Youngquist et al., 1995; Geysen et al., 1996; Hughes, 1998; Wagner et al., 1998), pulsed ultrafiltration (van Breeman et al., 1997), and antiaggregatory approaches (Park et al., 2000) have been described. The two distinguishing features of LC/MS-based strategies for lead identification screening appear to focus on either the chromatography format or the accurate mass capabilities. In this section, several examples are described to highlight emerging applications of LC/MS for lead identification screening activities. The first example emphasizes the use of a novel chromatography format for bioaffinity-based screens while the remaining examples demonstrate the power of accurate mass measurements in conjunction with standard HPLC methods for screening combinatorial libraries.

Bioaffinity Screening Combinatorial chemistry has changed the strategy of drug candidate synthesis. As a result, hundreds of thousands of compounds are now screened against a particular biological target. Once activity is determined for a mixture, the identification of the active component(s) is necessary. One strategy is to iteratively resynthesize subpools of the mixture. However, this approach requires considerable resources. To reduce the time and resources required for screening the large number of compounds produced by combinatorial chemistry, approaches featuring the parallel screening of mixtures of compounds (20–30) have been investigated. Studies performed by Anderegg and co-workers describe the use of bioaffinity selection LC/MS methods for the identification of active mixture component(s) (Davis et al., 1999). This approach features an integrated bioaffinity-based LC/MS screening method to separate and identify compounds from mixtures.

This work is an extension of previously described studies performed by Nedved, Dollinger, and co-workers (Nedved et al., 1996; Kaur et al., 1997), where ligands are injected onto chromatography columns that contain target proteins to observe various degrees of “selection.” Compounds that bind to the proteins are selectively bound to the column and are eluted for identification. Other studies have reported on the successful use of ultrafiltration membranes to selectively retain compounds that are bound to target proteins (van Breeman et al., 1997; 1998). Unbound molecules pass through the membrane and the bound molecules are released and identified.

In the approach described by Anderegg and co-workers, LC/MS is incorporated as a bioaffinity screening strategy for lead identification in drug discovery. A mixture of compounds is incubated with the target protein and the components bound to the protein are selected by using a size exclusion chromatography (SEC) spin column. In this experiment, the unbound compounds are retained on the column. The bound components are eluted and identified with LC/MS. Figure 6.10 illustrates the spin column enrichment scheme. Increased specificity is obtained by dissociating the bound compounds and performing a second equilibration incubation with the protein. This procedure preferentially selects for the compounds with higher affinity and results in an enhancement of the quantitative LC/MS response. Iterative stages of incubation, size-exclusion, and LC/MS allow the tighter binding components to be enriched relative to weaker binding components.

In this study, the peroxisome proliferator-activated receptor

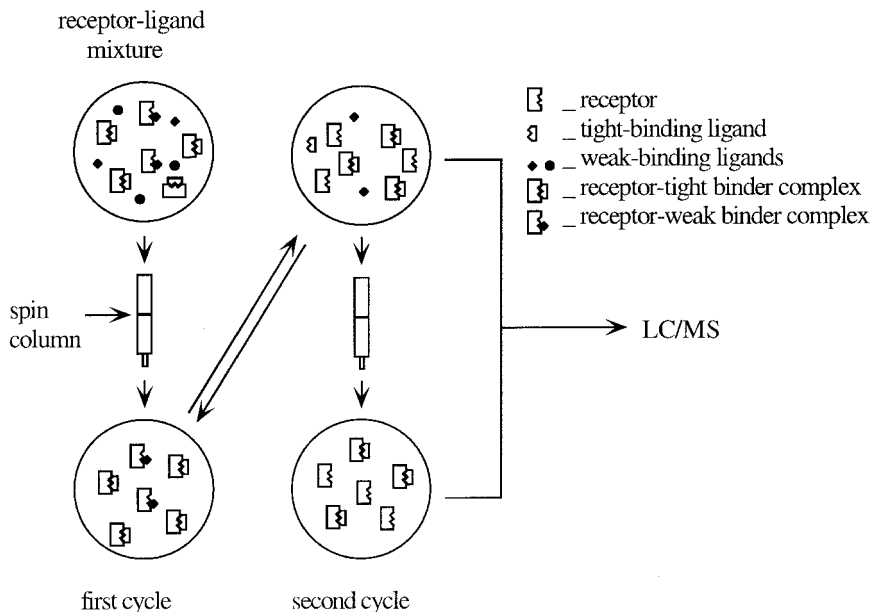

Figure 6.10 Procedure for bioaffinity screening of combinatorial drug candidates libraries with two cycles of iterative size exclusion chromatography, using spin columns to separate the receptor and receptor-binder complexes from unbound ligands. (Reprinted with permission from Davis et al., 1999. Copyright 1999 American Chemical Society.)

(PPAR γ), which is a target for antidiabetic drugs (construct molecular weight of 32,537 Da), is incubated with ten ligands that range in molecular weight from 283 to 587 units. A spin column of 6,000 Da cutoff is used for SEC purposes. The retained mixture of components is analyzed by fast perfusive chromatography (Regnier, 1991; Afeyan et al., 1991), using a standard full-scan LC/MS strategy. This analysis procedure allows for the identification and quantitation of the protein and the ligands, compared to their responses prior to incubation. The ligand-protein complex that dissociated under the reversed-phase chromatographic conditions is selectively detected. The LC/MS response of the 10-compound mixture is shown in Figure 6.11. After one pass through the spin column, several weak-binding ligands (B, F, H) disappear, and several others diminish in relative amount (D, E, G). After a second pass through the spin column, the three weak-binding ligands (D, E, G) are further diminished. Four ligands remain, corresponding to the tight binders (A, C, I, J).

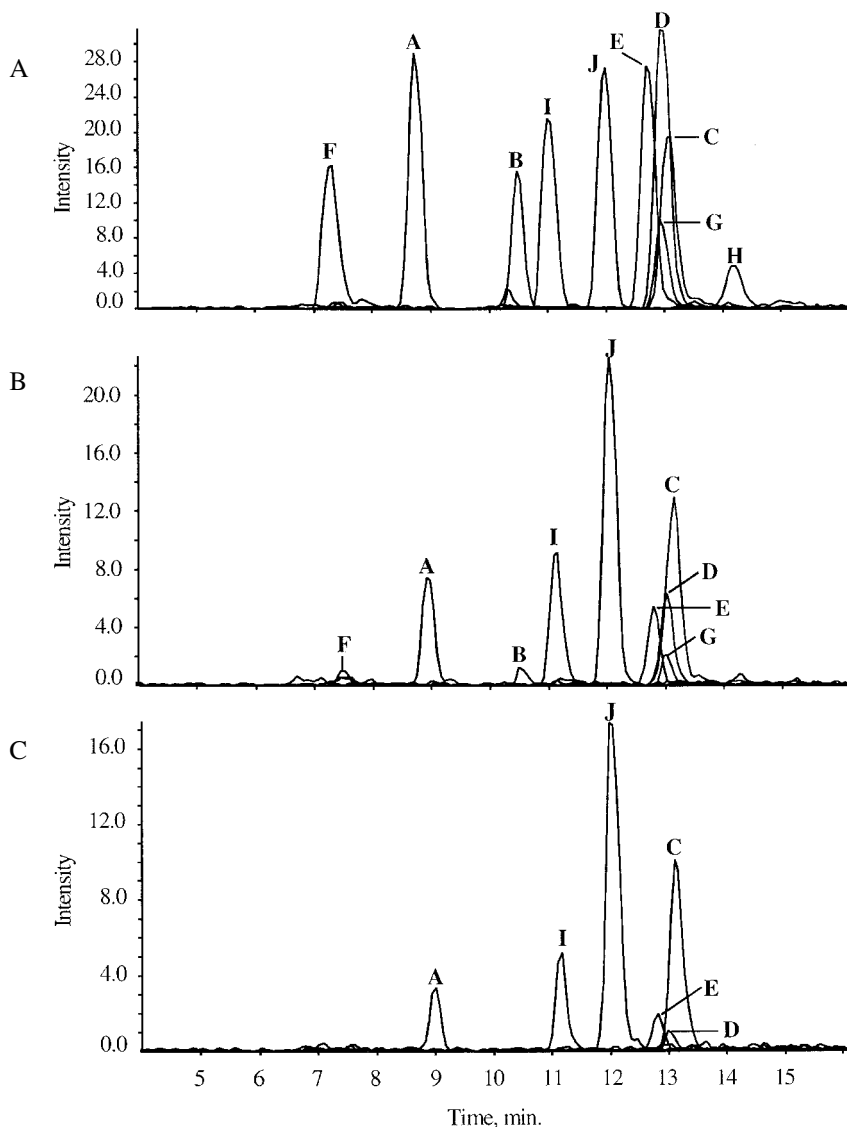

Figure 6.11 The LC/MS extracted ion current profiles for 10 combinatorial drug candidate library components, using the bioaffinity screening procedure shown in Figure 6.6. (A) Before passing through a spin column. (B) After one cycle. (C) After two cycles. The enhancement of tight-binding ligands is evident. (Reprinted with permission from Davis et al., 1999. Copyright 1999 American Chemical Society.)

This analysis scheme provides a quick measurement of binding affinity, and serves as a screening tool during drug candidate selection. Spreadsheets are constructed and used to calculate the binding affinity of the components. In this example, two incubation cycles followed by the SEC separation provide an enhancement of strong binders to weak binders. This LC/MS-based method provides a unique approach to obtain information in situations when lower concentrations of tighter binding ligands are present in the same mixture with higher concentrations of weaker binding ligands. Furthermore, this method is more efficient than synthetic deconvolution procedures and does not require the use of radioligands.

Combinatorial Library Screening LC/MS formats that provide accurate mass capabilities have compelling analytical features for the screening combinatorial libraries. The unambiguous confirmation/identification of combinatorial library components from small quantities of material have been illustrated using QTOF (Blom et al., 1998), TOF (Lane and Pipe, 1999), and Fourier transform ion cyclotron resonance (FTICR) (Huang et al., 1999; Speir et al., 2000; Fang et al., 2001) mass spectrometers. These formats provide accurate isotope patterns or “isotopic signature,” and unique mass differences between isobaric compounds are obtained. The approaches are similar to previously described methods (i.e., analysis, database searching) for proteomics and the dereplication of natural products (Strege, 1999).

In the novel ESI QTOF-MS approach described by Blom and colleagues (Blom et al., 1998), active combinatorial chemistry-derived lead compounds are identified by accurate mass and tandem mass spectrometry (MS/MS) measurements. Mixtures obtained directly from active beads of a dipeptide combinatorial library that was selected by ultrahigh-throughput screening protocols (for matrix metalloprotease activity) were analyzed with a single acquisition using an automatic function switching method. Figure 6.12 illustrates the ESI full scan and MS/MS product ion spectra for a compound released from a single bead after ultrahigh-throughput screening. An EXCEL program was used to generate a list of all components in the library, the exact masses of the $[M + H]^+$ peaks, and the masses of the four expected MS/MS product ions. This ESI-LC/MS methodology was developed to support a leads discovery program that required approximately 100 analyses/day.

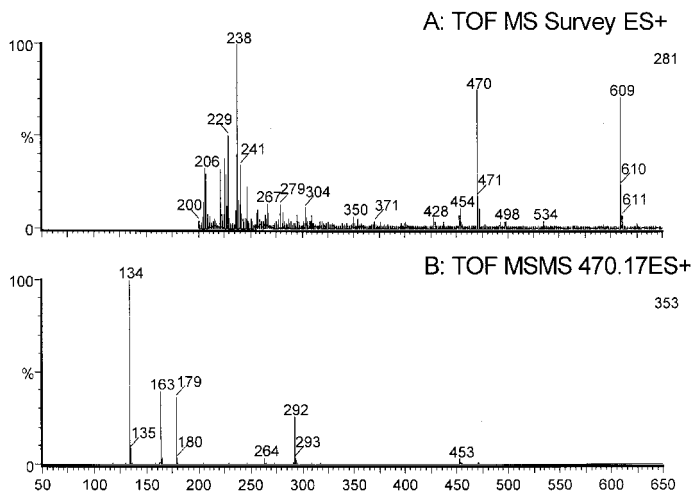

Figure 6.12 The positive ion ESI-MS and MS/MS product ion spectra of a compound released from a single bead after ultrahigh throughput screening. (Reprinted with permission from Blom et al., 1998. Copyright 1998 John Wiley & Sons.)

Typical measurements were made on approximately 20 pmol of compound. Automated data analysis routines provided (1) a quick survey of molecular weight based on $[M + H]^+$ masses and (2) qualitative measure of best fit based on specific tolerances for the calculated mass and resulting MS/MS product ions. This automated approach greatly minimized the possibility of error. Unequivocal identification of structures using an automated computer analysis is obtained in about 80% of the cases with a mass measurement accuracy of <5 ppm. Manual interpretation of mass spectra was then carried out to identify the compounds in the remainder of the samples.

The use of a generic microbore HPLC method in conjunction with an accurate mass TOF configuration was reported by Lane and Pipe (1999). In the previously described method, compounds obtained from single beads were measured directly. In this approach, identifier tags are attached to synthesis supports using a procedure referred to as encoded combinatorial synthesis (Brenner and Lerner, 1992). The identifier tags, a series of secondary amines, are added to the beads in a unique manner during library synthesis. After screening the encoded beads, the amines are released by acid hydrolysis, deriva-

tized with dansyl chloride, and analyzed by LC/MS. Unambiguous decoding of the biologically active components of the library is effectively simplified (i.e., known molecular weight, reproducible chromatography, consistent response) since the analytical method is optimized for detection of specific set of identifier tags as opposed to the chemical entities that they represent.

In the method described by Lane and Pipe (1999), a microbore LC/TOF-MS method was used to generate a quick separation of dansylated tags (Table 6.5) followed by accurate mass measurement of both molecular and MS/MS product ions. The 14-member tag set corresponds to unique molecular weights. The TOF-based approach provides a powerful advantage over scanning-type instruments (i.e., quadrupole) for this application and features parallel detection of all masses in the spectrum. The mass chromatograms for the $[M + H]^+$ species of the 14 dansylated tags (Figure 6.13) illustrate the chromatographic separation obtained using this methodology. The same microbore LC/TOF method was also used to analyze beads directly.

The feasibility of FTICR-based approaches for the screening of combinatorial libraries was demonstrated using flow injection (Fang

TABLE 6.5 The Affymax orthogonal 14-member tag set described by Lane and Pipe, 1999

| Tag | Name | Molecular Weight | Formula | Mol. Wt. of Dansyl Derivative |
|---------------------|------------------------------------|------------------|--|-------------------------------|
| D ₃ -EP | D ₃ -N-ethylpentylamine | 118.1549 | C ₇ H ₁₄ D ₃ N | 351.2060 |
| D ₃ -EH | D ₃ -N-ethylhexylamine | 132.1706 | C ₈ H ₁₆ D ₃ N | 365.2216 |
| D ₃ -EH' | D ₃ -N-ethylheptylamine | 146.1862 | C ₉ H ₁₈ D ₃ N | 379.2373 |
| D ₃ -EO | D ₃ -N-ethyloctylamine | 160.2019 | C ₁₀ H ₂₀ D ₃ N | 393.2529 |
| D ₃ -EN | D ₃ -N-ethylnonylamine | 174.2175 | C ₁₁ H ₂₂ D ₃ N | 407.2686 |
| D ₃ -ED | D ₃ -N-ethyldecylamine | 188.2332 | C ₁₂ H ₂₄ D ₃ N | 421.2842 |
| PO | N-pentyloctylamine | 199.2300 | C ₁₃ H ₂₉ N | 432.2801 |
| H'H' | Diheptylamine | 213.2457 | C ₁₄ H ₃₁ N | 446.2967 |
| H'O | N-heptyloctylamine | 227.2613 | C ₁₅ H ₃₃ N | 460.3124 |
| OO | Dioctylamine | 241.2770 | C ₁₆ H ₃₅ N | 474.3280 |
| PD _o | N-pentyldecylamine | 255.2926 | C ₁₇ H ₃₇ N | 488.3437 |
| HD _o | N-hexyldecylamine | 269.3083 | C ₁₈ H ₃₉ N | 502.3593 |
| H'D _o | N-heptyldecylamine | 283.3239 | C ₁₉ H ₄₁ N | 516.3750 |
| DD | Didecylamine | 297.3396 | C ₂₀ H ₄₃ N | 530.3906 |

Source: Reprinted with permission from Lane and Pipe, 1999. Copyright 1999 John Wiley & Sons.

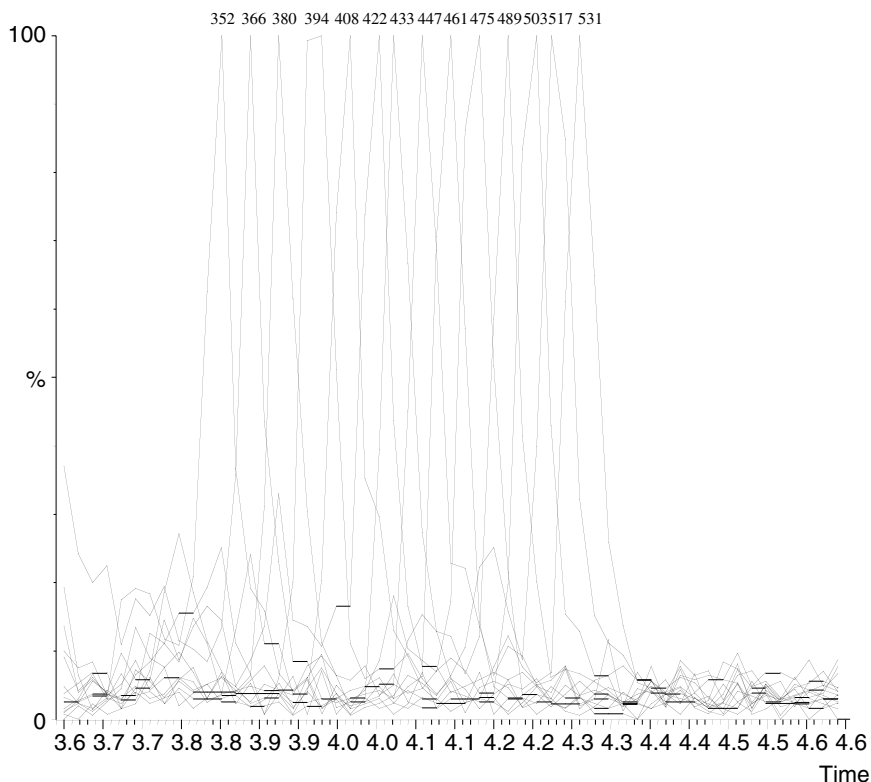

Figure 6.13 The mass chromatograms for the $[M+H]^+$ species of the 14 dansylated tags. (Reprinted with permission from Lane and Pipe, 1999. Copyright 1999 John Wiley & Sons.)

et al., 2001). Methods were developed so that exact mass measurements could be obtained in a routine manner resulting in the identification of 70–80% of the library components. This methodology is particularly useful for combinatorial libraries that contain isobaric components. Similar experiments that use fast gradient HPLC methods on-line with FTICR were demonstrated for the accurate mass analysis of mixtures (Speir et al., 2000). The high resolution, exact mass measurement provides insight into the molecular formula of unknown compounds and corresponding fragment ions. Using a reverse-phase HPLC method, a six-component drug mixture was analyzed in less than 5 minutes under high-mass accuracy conditions. Representative UV and LC/MS chromatograms obtained with the six-component mixture are shown in Figure 6.14. Relative mass

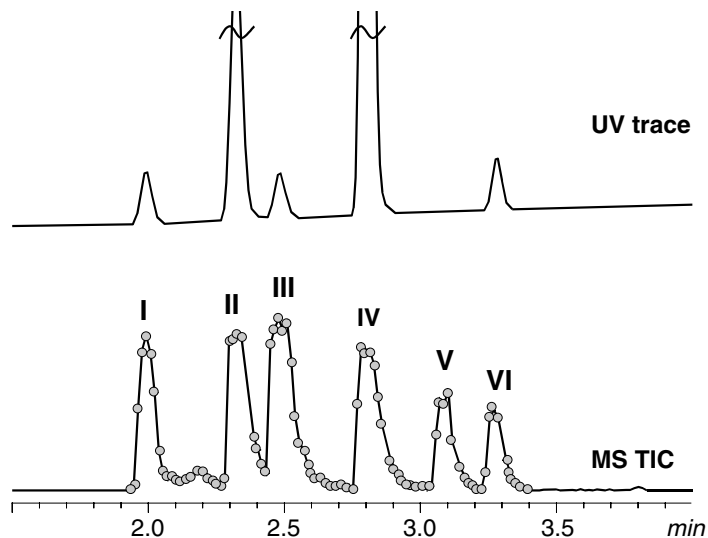

Figure 6.14 Representative LC/UV and LC/FTICR-MS chromatograms obtained from a six component mixture. The solid circles represent temporal location of mass spectra with an acquisition time of 1 s. (Reprinted with permission from Speir et al., 2000. Copyright 2000 John Wiley & Sons.)

errors of less than 1 ppm are obtained. With the use of 3 sec acquisition times, on-line LC/FTICR-MS/MS results are possible using this methodology.

Open-Access LC/MS

In the early 1990s, the notion that LC/MS could be developed into an automated, walk-up system for structure characterization of medicinal lead compounds was prevalent. At the time, mass spectrometers were becoming more stable and easier to use. Microprocessor control, robust ion optics, detectors, reliable LC/MS interfaces, and autosamplers created a high degree of sophistication as well. These improvements, combined with the realization that molecular mass was sufficient for structure confirmation of synthetic products, led to a qualitative shift in lead compound characterization.

For many years, medicinal chemists were accustomed to open-access or “self service” nuclear magnetic resonance (NMR) and infrared (IR) spectroscopy for routine and rapid confirmation of molecular structure. An open-access structure provides a convenient

environment to follow synthetic schemes in process and to facilitate the gathering of information, thus allowing chemists to proceed quickly and efficiently to the next step of synthesis. During this time, medicinal chemists experienced tremendous pressure to be productive. At the same time, analytical chemists became inundated with samples. Clearly, traditional NMR and IR approaches were not feasible due to sample quantity and throughput limitations. The mutual need was to devise alternate approaches. LC/MS methods, using an open-access format, were first developed as a primary means of structure confirmation (Taylor et al., 1995; Pullen et al., 1995). This approach validated the belief that monoisotopic molecular mass was sufficient for the structure confirmation of synthetic products and that detailed spectral interpretation was not necessary during this drug discovery activity. In general, these approaches feature integrated analysis strategies that emphasized simplicity with less detail.

Open-access LC/MS systems provide an effective means for maintaining the high-throughput characterization of synthetic compounds. These systems offer an efficient laboratory- to bench-scale integration of sample generation and analysis activities. Advances in analytical instrumentation and electronic communication have also played a major role in the emergence and acceptance of LC/MS as a frontline tool for structure characterization. From an industry perspective, these advances were significant catalysts for the acceptance of LC/MS analysis responsibilities by mainstream sample generators (i.e., medicinal chemists).

The applications highlighted in this section focus mainly on medicinal chemistry support. A review by Burdick and Stults indicates that a similar methodology may be adapted for the analysis of peptide synthesis products, using ESI-MS techniques (Burdick and Stults, 1997). The application of LC/MS for peptide analysis is similar to the previously described schemes for chemical synthesis and purification and focuses on confirmation of the desired peptide and identification of synthetic by-products.

Structure Confirmation In the open-access LC/MS procedure described by Pullen and co-workers, the samples are directly introduced from solution for ease of automation and sample preparation. Chemists prepare samples in solvent to a suggested concentration range, then log the samples into the system. The sample log-in is done at any time during the continuous automated queue. Autosampler vials are used to hold the samples, and autosamplers are used to

directly deliver samples in solution to the mass spectrometer. The system uses a standard method to analyze the samples in queue, average spectra according to a preset scheme, and print out a spectrum for the chemist. Fail-safe procedures for untrained users and instrument self-maintenance at start-up and shutdown were also developed.

The LC/MS analyses were performed with either thermospray ionization (TSI) or particle beam (PB) interfaces. These systems successfully analyzed the labile, polar, or higher mass compounds, whereas a complementary gas chromatography (GC)/MS system was used for volatile compounds. The LC/MS system proved to be widely applicable to a range of chemically diverse compounds. The TSI and PB systems were both successful for 80–90% of the compounds analyzed. Automated, open-access LC/MS analyses performed well because sample throughput was expected to reach 250,000 in 1995. This throughput corresponds to approximately 1000 samples per day.

Development of the method involved the installation of a system in an existing mass spectrometry laboratory and working with chemists for 3 months to determine specific needs and to develop a consistent, reliable procedure. The instrument was moved to an open-access laboratory and chemists were trained in its use. A key to making this approach a success is the fact that instrument downtime was kept to a minimum. Understandably, maintenance is done at off-peak times, and support mechanisms are put in place so problems are immediately addressed. Training and education was highlighted as a key factor for the successful implementation of this LC/MS system to optimize performance and to reduce the possibility of instrument contamination.

In 1995, Taylor and co-workers also described the use of an open-access LC/MS system for routine structure confirmation, featuring atmospheric pressure chemical ionization (APCI). This system featured dual personal computers (PCs) for automated instrument control and sample log-in. A system-PC is responsible for running the Windows NT for Workgroups operating system and interfaces with the network for instrument control. A separate log-in PC, isolated from the LC/MS system, is used by the synthetic chemist to enter details about the samples. The analyst prepares the sample in an autosampler vial in one of several solvent options. The system specifies where to place the sample vial in the autosampler, and following analysis with a standard method, spectra are automatically processed and printed without any chemist intervention.

An average of 76 samples per day was analyzed over a 6-month period in 1995, for a total of approximately 8000 samples. This rate compares with 20–30 samples per day output prior to introducing the open-access LC/MS system. The total cycle time is less than 4.5 min per sample. The APCI method, when 60 representative compounds were tested, generated more intense molecular ions, less fragmentation, and better signal/noise ratio than TSI. The ESI approach was found to be a softer ionization method, but produced multiply charged ions and a higher chemical background than APCI did. Typically, $[M + 1]^+$ and $[M + 23]^+$ ions, corresponding to protonated and sodiated molecules, respectively, are observed with ESI. The APCI technique produces intense molecular ions for the variety of compounds with little fragmentation. No significant memory effects are observed from sample to sample, due to the 4 min cycle, during which time the mobile phase self-cleans the system. As highlighted with the previous example, the ability to generate simple, predictable, easy to interpret mass spectra without significant contamination from sample to sample is of paramount importance for success.

Taylor and co-workers further demonstrated the value of open-access LC/MS systems for generating a widened scope of pharmaceutical analysis applications, including: (1) characterization of synthetic intermediates and target compounds; (2) reaction monitoring; (3) reaction optimization; (4) analysis of preparative HPLC fractions; and (5) analysis of thin layer chromatography (TLC) plate spots. The availability of these methods led to the increased use of LC/MS for structural analysis. The short analysis time and reliable structure confirmation resulted in the use of LC/MS as a first choice for structure characterization for synthetic chemistry applications, as well as an expanded, and perhaps, integrated role of sample generator and analyst.

Chemists now routinely use open-access LC/MS in the same way that they previously used TLC to monitor reaction mixtures for the desired product and to optimize reaction conditions. In practice, medicinal chemists require only molecular mass data and are comfortable with a variety of ionization methods to obtain this information. However, confidence in the actual method and procedure is a requisite. Today, molecular mass measurement has quickly become a preferred means of structure confirmation over NMR and IR during the early stages of synthetic chemistry activities, where sample quantities are limited.

High Throughput An important development in the quest for high-throughput combinatorial library analysis was the multiple ESI interface described by Wang and colleagues (Wang et al., 1998; 1999). This novel ESI interface enables effluent flow streams from an array of four HPLC columns to be sampled independently and sequentially using a quadrupole mass spectrometer instrument. The interface features a stepping motor and rotating plate assembly. The effluent flow from the HPLC columns is connected to a parallel arrangement of electrospray needles coaxial to the mass spectrometer entrance aperture. The individual spray tips are positioned 90 degrees relative to one another in a circular array. Each spray position is sampled multiple times per second by precise control of the stepping motor assembly.

A parallel sample analysis format using a multiplexed LC/MS interface with an orthogonal TOF MS was described by Organ and co-workers (de Biasi et al., 1999). This approach demonstrated the high-throughput capabilities of a multiplexed ESI interface in combination with a mass spectrometer format that accommodated fast chromatography methodologies. This system features a four-way multiplexed electrospray interface attached directly to the existing source of the TOF-MS instrument (Figure 6.15). A rotating aperture driven by a variable speed stepper motor permits the sampling of the spray from each electrospray probe tip. The acquisition of data files is synchronized with the corresponding spray. Each spray is sampled for 0.1 sec, and mass spectra are acquired from 200–1000 Da. The total cycle time for each spray position is 0.8 sec.

Open-access LC/MS formats have spawned new dimensions in data management and access. Versatile software packages for data manipulation and processing have been a popular approach for integrating analysis and information (Whitney et al., 1998; Tong et al., 1999; Richmond et al., 1999; Huang et al., 1999; Yates et al., 2001). These software programs were efficiently implemented with either stand-alone computers or servers that were networked with open-access mass spectrometer data systems (Figure 6.16). With this specific configuration, the data are generated, visualized, processed, and automatically reported to the chemist. The program then compares a template of predicted molecular ions with the actual ions generated by ESI or APCI to permit quick determination of synthetic products, intermediates, reactants, reagents, and contaminants. Observed ions and known artifact ions are generated in a list format

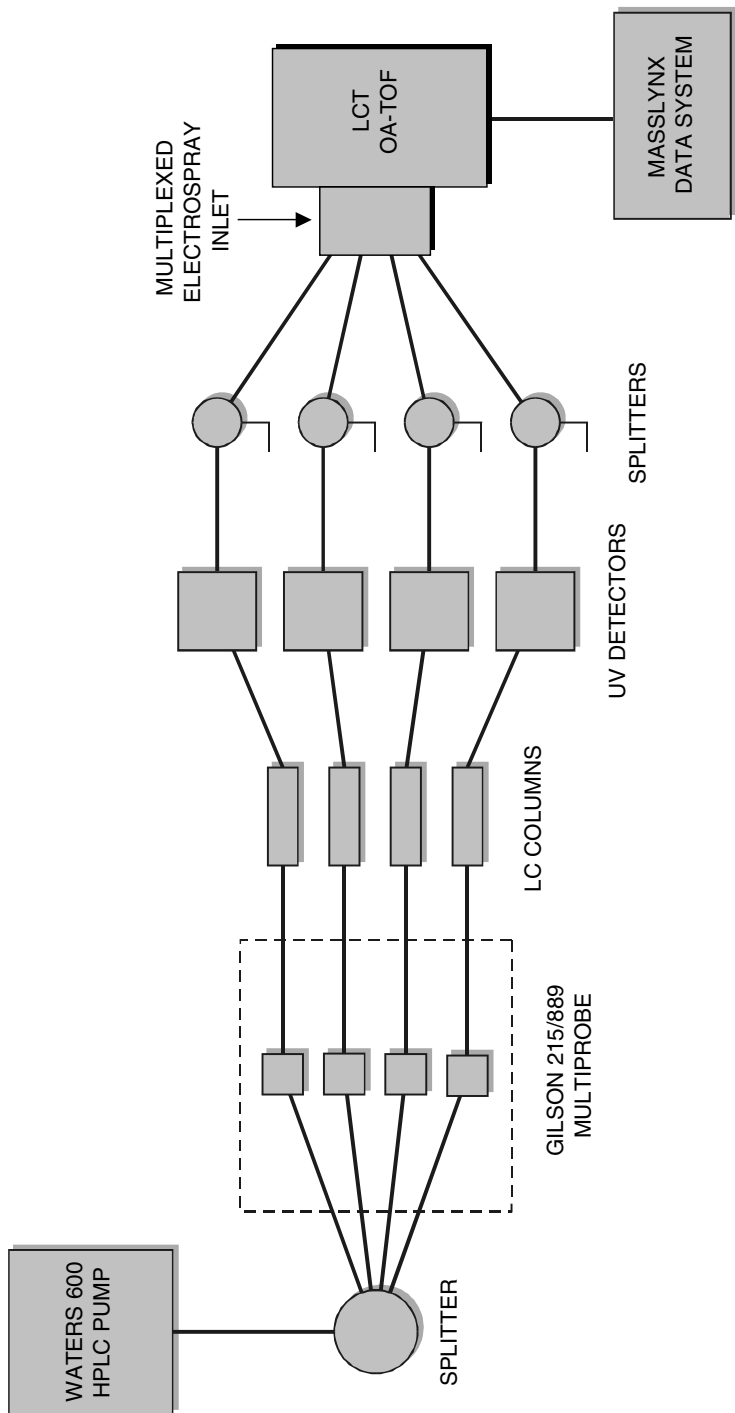

Figure 6.15 The schematic of the four-way multiplexed electro spray LC/MS interface in combination with a TOF-MS. (Reprinted with permission from de Biasi et al., 1999. Copyright 1999 John Wiley & Sons.)

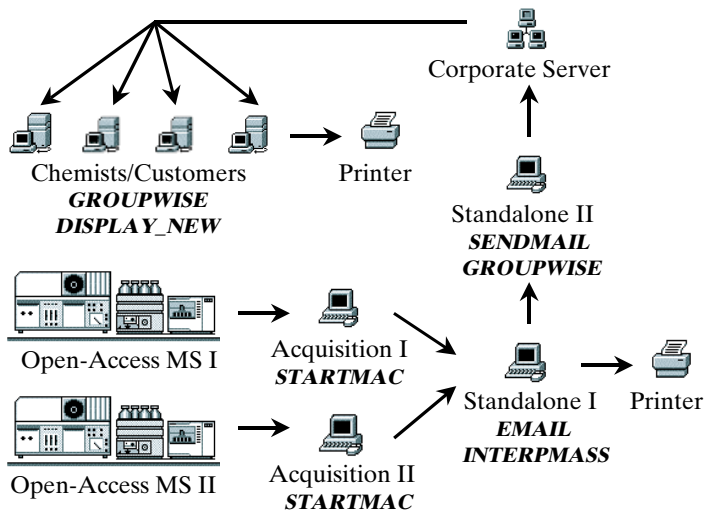

Figure 6.16 Software packages for data manipulation and processing, using standalone computers and servers that are networked with open-access mass spectrometer data systems. (Reprinted with permission from Tong et al., 1998. Copyright 1998 Elsevier.)

and used to provide a measure of the quality of fit to the predicted product(s).

Purification A variety of creative and innovative open-access LC/MS formats were developed to address throughput needs within the industrial laboratory. As the preparation of large libraries for lead discovery became routine, the burden placed on analytical techniques focused mainly on throughput *and* quality (Kyranos and Hogan, 1998; Van Hijfte et al., 1999). Biological assay requirements, however, normally required pure compounds. Thus, the focus shifted toward the use of automated high-throughput purification methods applied to libraries of discrete compounds (Weller, 1998–99).

Reverse-phase analytical and preparative HPLC methods have been critical for the high-throughput purification of components in parallel-synthesis libraries. A variety of approaches that feature the use of gradient methods, short columns, and high flow rates were described (Weller et al., 1997). Highly automated LC/MS approaches for purification at the multimilligram level were described by Zeng and colleagues (Zeng et al., 1998a). These methods involve the use of short columns that are operated at ultra high flow rates. Prepara-

tive columns are operated at flow rates in excess of 70 mL/min to match the linear velocity of the short analytical columns (4.0 mL/min). Analytical LC/MS analyses of compound libraries are achieved in 5 min for chromatographically, well-behaved compounds. Slightly longer preparative LC/MS analysis times (8–10 min/sample) are required for compounds that exhibited poor chromatographic peak shapes and/or for compound mixtures that required higher resolution separations.

The schematic of the parallel analytical/preparative LC/MS-based system devised by Zeng and Kassel (Zeng and Kassel, 1998; Zeng et al., 1998b) is shown in Figure 6.17. The fraction collection process is initiated in real-time once the reconstructed ion current is observed for an ion of a specific m/z value that corresponds to the compound of interest. This design permits the collection of one sample per fraction. Thus, the need for very large fraction collector beds and post-purification screening and pooling was eliminated. Unattended and automated operation of this system led to the purification of more than 100 compounds (mg quantities) per day.

Combinatorial Mixture Screening The increased popularity of LC/MS-based methods combined with limited resources resulted in advances that effectively matched combinatorial chemistry samples (i.e., complexity) with instrument time. Richmond, Yates, and co-workers (Richmond et al., 1999; Yates et al., 2001) demonstrated the use of flow injection analysis (FIA)-LC/MS systems for rapid purity assessment and combinatorial mixture screening, respectively. These LC/MS-based applications addressed two critical bottlenecks: HPLC

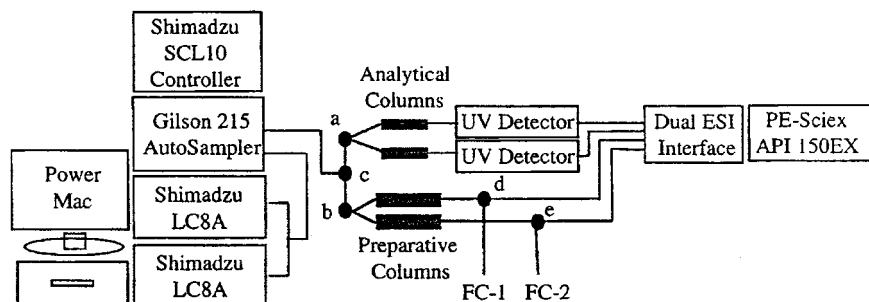

Figure 6.17 The schematic of the parallel analytical/preparative LC/MS system devised by Zeng and Kassel. (Reprinted with permission from Zeng and Kassel, 1998. Copyright 1998 American Chemical Society.)

method development and quick delivery of results to the synthetic chemists.

The approach developed by Richmond and colleagues (Richmond et al., 1999) employed a FIA-LC/MS method to generate purity estimates and determine the success of the synthesis. A 96-well sampling plate is used as the standard format for handling LC fractions. Comparability between plates is achieved by using a series of yohimbine standards (installed in row A). The mass spectrometer is operated in the ESI positive and negative ion modes. A software application developed in-house within a Visual Basic graphic interface program is used to provide a color representation of the MS results with numerical purities contained within the background. Figure 6.18 illustrates the four primary displays used by the chemists to select analysis preferences and determine the success of their synthesis. The purity results are defined by summing the ion current of the expected compound (includes the molecular ions and adducts)

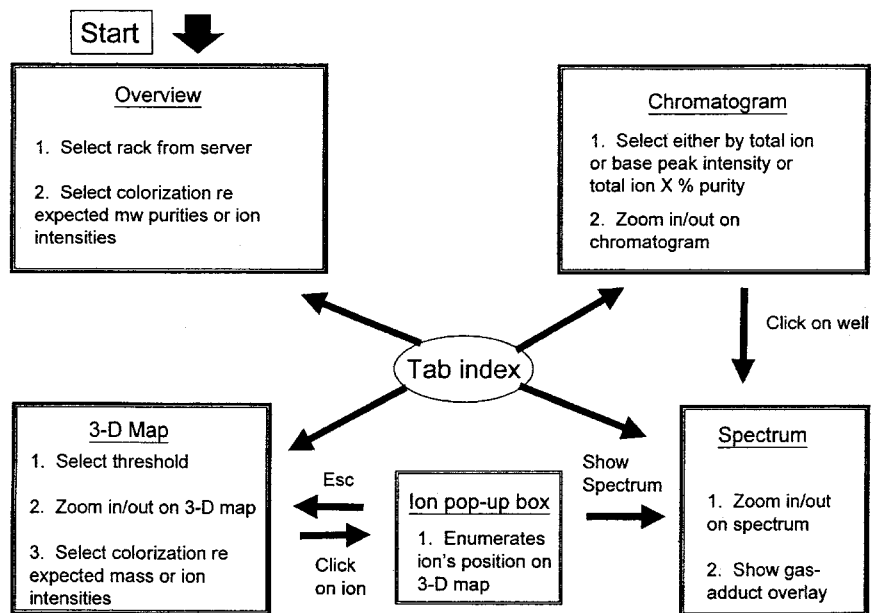

Figure 6.18 The four main displays from the in-house Visual Basic interface program developed at Novartis Pharma. The chemists use this program to select their samples/racks from a central server and access chromatograms, spectra, and 3-dimensional maps displays. (Reprinted with permission from Richmond et al., 1999. Copyright 1999 Elsevier.)

divided by the TIC. The purity results from each sample plate also can be represented in three-dimensional maps with a specified color scheme. This representation is a quick approach for surveying and delivering LC fraction data. The facile visualization of data provides both an enabling and powerful tool for judging the success of a chemical synthesis. The data input by the chemist as well as the results reported by the analytical chemist are networked throughout the geographically dispersed research facilities. The data are processed and results are returned to the chemist within 24 hr. The chemist can then assess whether to proceed to an LC/MS method in which the LC conditions are optimized.

The methods devised by Yates and co-workers (Yates et al., 2001) features the use of FIA-LC/MS to simultaneously measure (i.e., LC/MS analysis) and analyze (i.e., data processing, informatics) combinatorial libraries. The intent of this approach is to generate low-resolution mass spectra of large combinatorial mixtures and combine high-throughput data processing programs and informatics tools to assess overall library integrity. Full scan mass spectra are obtained from the complex mixtures and are correlated with libraries of predicted ESI mass spectra using a Microsoft Excel Visual Basic Application. Correlation analysis of the measured and predicted intensities at all m/z values generates purity scores for each mixture. The FIA-LC/MS analysis of a 96 well microtiter plate is performed in about 2.5 h while data analysis requires approximately 30 min. All results are then transferred to a WebServer for access by the chemists. Figure 6.19 shows the measured and predicted mass spectra for a 280 component mixture. Visual inspection of the two spectra indicates that some the expected products are present in the mixture. Correlation analysis yields a compound score of 0.73 and a purity score of 0.64, indicating that much of the measured signal does not correlate well with the ions in the predicted spectrum. A Lib View computer program is used to facilitate the analysis and serves as the link between scientists and the data. Figure 6.20 shows the computer screen capture from the Lib View program with the measured and predicted mass spectra in the foreground. A color spectrum relates the color of the sample wells to the value of the purity score. A high score approaches 1 (blue) and a low score approaches -1 (red). Empty wells are left uncolored. The use of the Lib View program provides a quick qualitative view of components present in a combinatorial library and significantly reduces the time required to process and review FIA-LC/MS data.

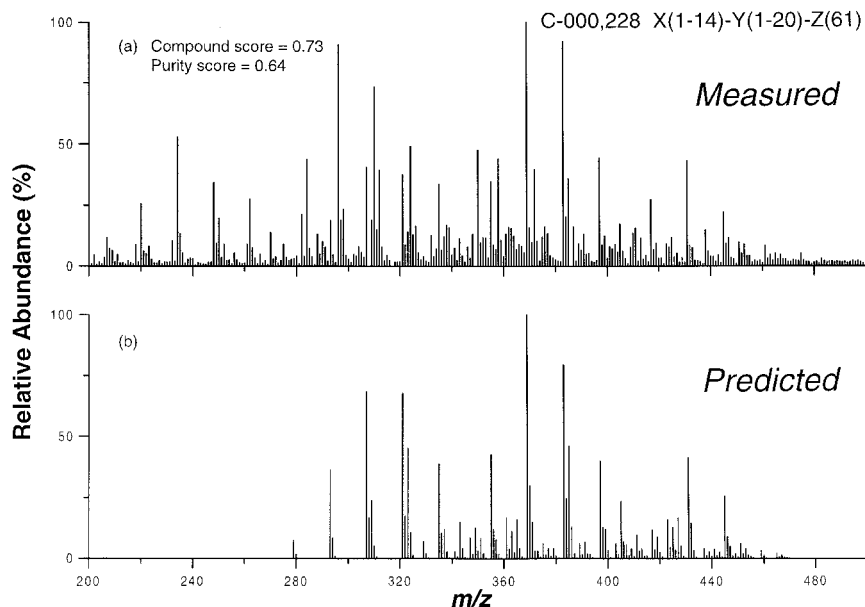

Figure 6.19 Comparison of the (a) measured and (b) predicted mass spectra of a 280 component mixture of combinatorial library C-000,228. (Reprinted with permission from Yates et al., 2001. Copyright 2001 American Chemical Society.)

In vivo Drug Screening

Advances in technologies, such as combinatorial chemistry, combined with initiatives calling for the faster evaluation of lead compounds, resulted in a tremendous interest in establishing technology for automated high-throughput bioanalysis. These analyses focused on methods for determining multicomponent mixtures of drug candidates that involve pharmacokinetics and metabolic stability. These activities were traditionally (and still are) positioned during the pre-clinical and clinical stages of drug development. However, the need to provide an early assessment of these properties resulted in new strategies for in vivo drug screening during the drug discovery stage.

Methods and approaches that can simultaneously determine mixtures of drug candidates provide a powerful way to select an optimal drug candidate within a specific therapeutic area or a targeted class of compounds. Using relatively simple isolation and chromatography conditions, LC/MS/MS approaches are an effective way to evaluate new lead compounds for subsequent development. Consequently,

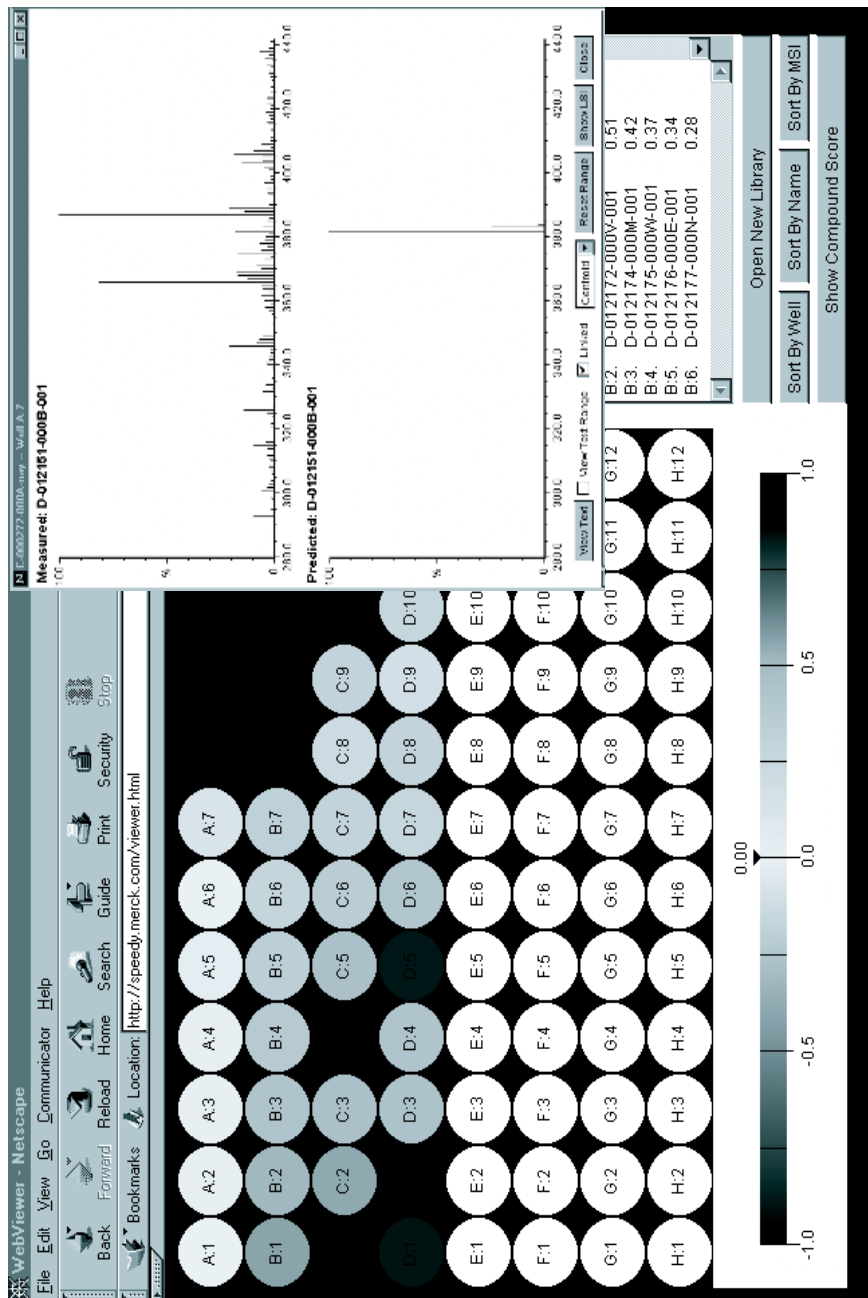

Figure 6.20 Computer screen capture of the Lib View library analysis program that illustrates the microtiter plate layout with the measured and predicted spectra shown in the foreground. (Reprinted with permission from Yates et al., 2001. Copyright 2001 American Chemical Society.)

the use of LC/MS-based screens has emerged and was successfully applied to large numbers of substances derived from either plasma obtained from animals dosed with a mixture containing several test substances or from pooled plasma from an animal that was sampled at specific time points.

In general, standard methods applicable to a vast majority of compounds of interest to ensure throughput capabilities are critical for LC/MS screens. Although not optimized for specificity, standard conditions provide a systemic measure of control. This control results in data that has high quality, reliability, and comparability. With a strategic selection of compounds that have similar molecular weights, structural features, and chromatographic properties, the detection selectivity and precision are satisfactory for this particular type of analysis.

The premise of this approach is to provide a mechanism for evaluating vast quantities of samples and forwarding on a select group for further testing, using traditional, more rigorous approaches. A key to screening is to establish an appropriate method that allows for high-throughput characteristics, while providing for an adequate level of discrimination. Development of an LC/MS-based screen involves a simplification of the overall experiment (i.e., method, expected results, interpretation). For example, an LC/MS method is simplified when it is widely applicable to the majority of compounds under investigation, and it provides yes/no or pass/fail results. This binary mode LC/MS screening is perhaps the simplest experiment for dealing with large amounts of data. Extensions to this approach can be designed to offer specific information from the screen, whether binary or more comprehensive. In any case, the threshold criteria for acceptance or failure define the method.

Typically, screen performance, emphasizing high-throughput qualities, has less discriminating features. Incorporating more discriminating features may result in longer analysis times and/or more attendant data interpretation. The strategy is to provide a screen that satisfactorily meets performance standards and maintains throughput requirements.

Once an LC/MS-based screen is developed and locked in for use (i.e., established as the standard method for subsequent analyses), the object is to arrive at the most promising lead compounds within a series quickly without the traditional, rigorous testing and analysis of each candidate separately. The reward is a significant saving in time and resources. The inherent risk is devising a discriminatory

screen that actually discards legitimate drug candidates! The reality is that each screen will likely be unique and highly dependent on instrumentation, technology, method, scientist(s), and scientific/business culture.

The development of an LC/MS-based screening method is not intuitive. The object is to devise a method that can significantly impact sample throughput without compromising the quality of data. The strategy is to forego detail while maintaining quality. A realistic starting point for LC/MS screening is an approach that uses the so-called 80/20 Rule (Lee et al., 1997; Heller and Hindle, 1998). This approach sets the criteria for method development, method refinement, and screen performance.

High-throughput bioanalysis screening approaches involve the characterization of full-scan mass spectra and MS/MS properties to determine the predominant molecular and product ions, respectively. This information is useful for the selection of appropriate ions for selected reaction monitoring (SRM) experiments. Settings such as collision energies and collisionally induced dissociation (CID) pressure or gas thickness can be optimized as well. Typically, the most abundant product ion is selected for SRM. Various acquisition software programs are used to perform the experiment, display the results, and process the data in an automated fashion.

Pharmacokinetics The screening of candidate compounds with animal models involving rats and/or dogs have been developed for pharmacokinetic screening-based studies in drug discovery (Olah et al., 1997; Berman et al., 1997; Shaffer et al., 1999; Korfmacher et al., 2001). The simultaneous pharmacokinetic assessment of multiple drug candidates in one animal has been termed *n-in-one dosing* or *cassette dosing*. This parallel approach results in an increased productivity for bioanalysis during drug discovery.

In the application described by Olah and workers, LC/MS-based methods are used to simultaneously assay plasma concentrations of up to 12 substances. The plasma is obtained from either single animals dosed with mixtures of lead compounds, or from multiple animals dosed with a single lead compound, after which aliquots of plasma from common time points are pooled. Essentially, simplified, less stringent versions of preclinical/clinical development procedures are used for sample preparation, assay validation, and analysis. A plasma concentration-time profile obtained from a dog administered simultaneously with 12 compounds is shown in Figure 6.21. Each

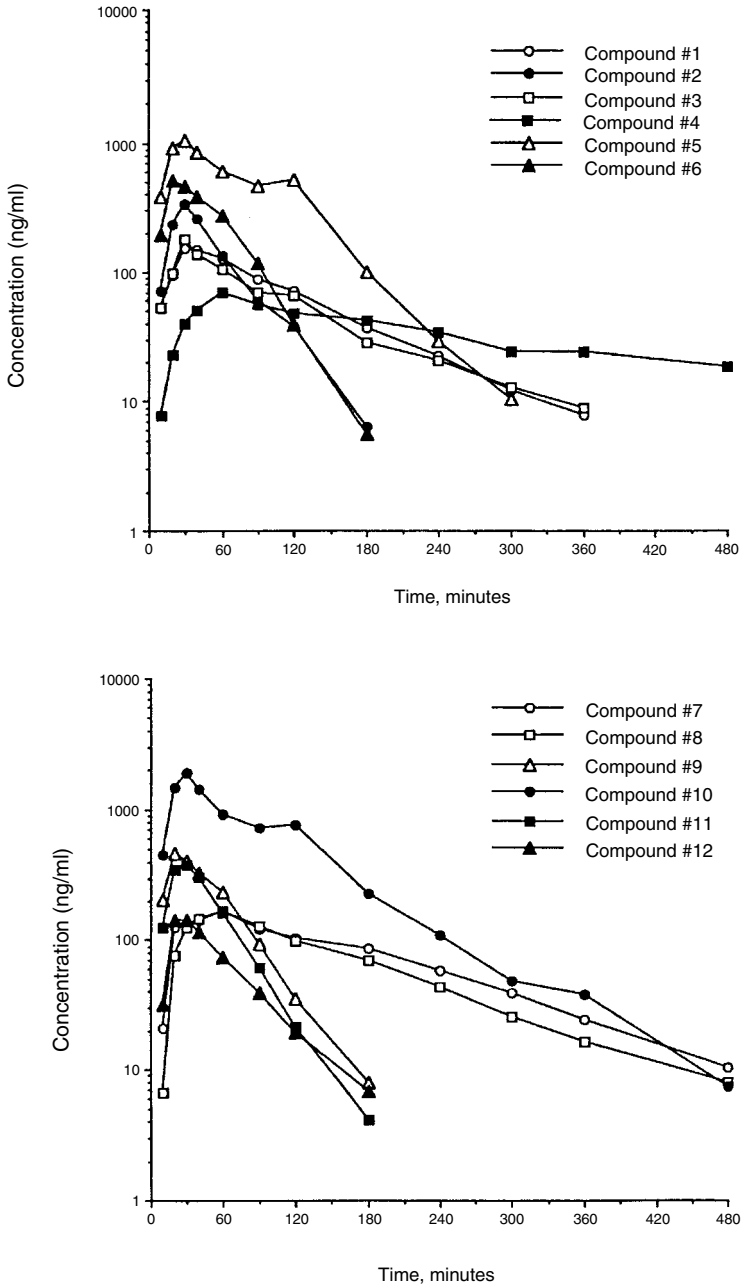

Figure 6.21 Plasma concentration-time profiles of 12 compounds given orally as a mixture to a single dog. (Reprinted with permission from Olah et al., 1997. Copyright 1997 John Wiley & Sons.)

compound is quickly evaluated relative to other compounds in the series and comparisons can be made. Desirable pharmacokinetic profiles are assessed, and the total number of samples analyzed is reduced significantly. In studies that involve the dosing mixtures of lead compounds, the number of animals required is significantly reduced. This methodology provides a perspective on traditional quantitative LC/MS/MS approaches for the analysis of drugs and their metabolites that are contained in biological fluids. Although traditional LC/MS approaches provide a straightforward way of assessing preclinical pharmacokinetic properties, the volume of drug candidates generated via automated synthesis routines combined with the requirements for turnaround time made this approach costly and time-consuming during drug discovery.

The application of APCI-LC/MS techniques for the rapid determination of protein binding and pharmacokinetics during the discovery stage was described by Allen and colleagues, using a single quadrupole instrument (Allen et al., 1998). A cocktail approach consisted of 4 experimental compounds and a control compound dosed orally at 1 mg/kg with plasma samples obtained at 0.5, 1, 2, 4, and 8 h postdose. To ensure reproducibility, the control compound was tested with each cocktail. This approach generated timely systemic exposure (AUC and C_{\max}) data on 44 test compounds in 3 work days, using two laboratory scientists.

The use of LC/MS/MS-based screening approaches for quantitative bioanalytical measurements allows a large, chemically diverse range of potential drug candidates to be analyzed quickly and confidently. The development of unique LC/MS-based systems for *in vivo* pharmacokinetic screening reduces the analysis to a manageable number of samples and results in a cost-effective approach to evaluate new lead compounds. Approaches to this type of methodology will likely vary, according to the behavior of the molecules of interest, standard operating procedures (SOPs), performance capabilities of the mass spectrometer, integration of automated sample preparation, and data analysis procedures. Success will likely depend on the foregoing parameters and the degree of tolerance to which the specific screen is set.

Beaudry and colleagues (Beaudry, 1998) investigated the extension of the *n*-in-one methodology to study larger numbers of compounds in each mixture, and to integrate sample preparation with the LC/MS/MS system for increased efficiency. The number of analytes studied in parallel was extended to 63 plus an internal standard.

A list of the 64 analytes and their method performance is shown in Table 6.6. The increased number of analytes is possible because of improvements to the collision region of the MS/MS system that provide increased sensitivity and reduced memory effects. In addition, robotic systems for sample handling and on-line solid-phase extraction (SPE) of plasma samples were integrated with the LC/MS/MS system (Figure 6.22). An isocratic reversed-phase HPLC method provided a cycle time of 4.5 min per sample. The on-line sample preparation and short analysis resulted in an increased sample throughput that required less time from the scientist. The

TABLE 6.6 Results of an *n*-in-one experiment of the parallel LC/MS analysis of 64 analytes from the same plasma sample

| Drug Name | Extracted LOD (pg) | Anal. Range (ng/ml) | Range Values | R Values |
|----------------|-----------------------|------------------------|-----------------|----------|
| Alprazolam | 5 | 0.5–500 | 1000 | 0.995 |
| Astemizole | 100 | 1.0–500 | 500 | 0.993 |
| Beclomethasone | 25 | 0.5–500 | 1000 | 0.994 |
| Betamethasone | 25 | 1.0–500 | 500 | 0.989 |
| Bromazepam | 25 | 5.0–500 | 100 | 0.991 |
| Bromocriptine | 2500 | 20–500 | 25 | 0.991 |
| Bupropion | 25 | 0.5–500 | 1000 | 0.990 |
| Buspirone | 25 | 0.5–500 | 1000 | 0.994 |
| Butoconazol | 25 | 0.5–500 | 1000 | 0.998 |
| Carbamazepine | 25 | 0.5–500 | 1000 | 0.989 |
| Clemastine | 25 | 0.5–500 | 1000 | 0.991 |
| Clonazepam | 25 | 5.0–500 | 100 | 0.990 |
| Clonidine | 250 | 5.0–500 | 100 | 0.994 |
| Clotrimazole | | | Signal too weak | |
| Cortisone | 250 | 5.0–500 | 100 | 0.992 |
| Danazol | 1000 | 50–500 | 10 | 0.996 |
| Diltiazem | 25 | 0.5–500 | 1000 | 0.993 |
| Econazole | 25 | 1.0–500 | 500 | 0.996 |
| Estazolam | 25 | 1.0–500 | 500 | 0.990 |
| Famotidine | 1000 | 20–500 | 25 | 0.985 |
| Felodipine | 100 | 20–500 | 25 | 0.989 |
| Fenfluramine | 25 | 0.5–500 | 1000 | 0.991 |
| Fluconazole | 25 | 0.5–500 | 1000 | 0.998 |
| Flunitrazepam | 25 | 1.0–500 | 500 | 0.995 |
| Fluoxetine | 100 | 5.0–500 | 100 | 0.996 |
| Guanfacine | 250 | 5.0–500 | 100 | 0.991 |
| Haloperidol | 25 | 1.0–500 | 500 | 0.994 |

TABLE 6.6 *Continued*

| Drug Name | Extracted LOD (pg) | Anal. Range (ng/ml) | Range Values | R Values |
|-----------------|-----------------------|------------------------|-----------------|----------|
| Indapamide | 25 | 0.5–500 | 1000 | 0.993 |
| Indomethacine | 25 | 0.5–500 | 1000 | 0.996 |
| Indoprofen | 25 | 0.5–500 | 1000 | 0.991 |
| Itraconazole | | Internal standard | | |
| Ketoconazol | 100 | 5.0–500 | 100 | 0.993 |
| Ketorolac | 25 | 0.5–500 | 1000 | 0.995 |
| Lidocain | 25 | 0.5–500 | 1000 | 0.996 |
| Lidoflazine | 25 | 0.5–500 | 1000 | 0.992 |
| Lisinopril | 250 | 5.0–500 | 100 | 0.997 |
| Loperamide | 25 | 0.5–500 | 1000 | 0.995 |
| Lorazepam | 25 | 1.0–500 | 500 | 0.996 |
| Lormetazepam | 25 | 5.0–500 | 1000 | 0.995 |
| Medazepam | 100 | 5.0–500 | 100 | 0.996 |
| Miconazol | 25 | 1.0–500 | 500 | 0.999 |
| Midazolam | 100 | 1.0–500 | 500 | 0.990 |
| Naltrexone | 25 | 0.5–500 | 1000 | 0.995 |
| Nicardipine | 25 | 0.5–500 | 1000 | 0.995 |
| Nifedipine | 100 | 1.0–500 | 500 | 0.993 |
| Nimodipine | 25 | 1.0–500 | 500 | 0.997 |
| Nitrendipine | 25 | 1.0–500 | 500 | 0.996 |
| Nitrazepam | 25 | 0.5–500 | 1000 | 0.998 |
| Nizatidine | 250 | 5.0–500 | 100 | 0.993 |
| Ofloxacin | 1000 | 20–500 | 25 | 0.997 |
| Omeprazole | 25 | | Unstable signal | |
| Oxazepam | 25 | 0.5–500 | 1000 | 0.997 |
| Oxybutinine | 25 | 5.0–500 | 100 | 0.990 |
| Paroxetine | 100 | 5.0–500 | 100 | 0.997 |
| Penfluridol | 100 | 5.0–500 | 100 | 0.994 |
| Pentazocine | 25 | 0.5–500 | 1000 | 0.997 |
| Prazepam | 25 | 0.5–500 | 1000 | 0.997 |
| Propafenone | 25 | 1.0–500 | 500 | 0.993 |
| Ranitidine | 100 | 1.0–500 | 500 | 0.997 |
| Spiroinolactone | 250 | 5.0–500 | 100 | 0.999 |
| Temazepam | 25 | 5.0–500 | 500 | 0.992 |
| Terconazol | 250 | 20–500 | 25 | 0.995 |
| Terfenadine | 25 | 0.5–500 | 1000 | 0.992 |
| Zopiclone | 25 | 0.5–500 | 1000 | 0.996 |
| Average | 111 | | 574 | 0.994 |

Source: Reprinted with permission from Beaudry et al., 1998. Copyright 1998 John Wiley & Sons.

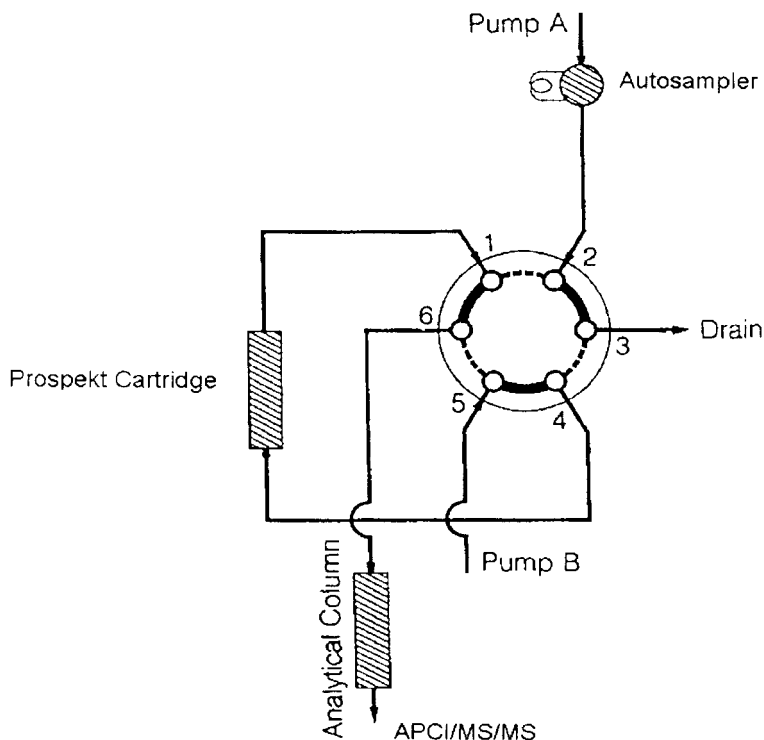

Figure 6.22 Diagram of a robotic Prospekt system for on-line SPE automated extraction integrated with LC/MS/MS analysis of plasma samples. (Reprinted with permission from Beaudry et al., 1998. Copyright 1998 John Wiley & Sons.)

method produced good performance, in terms of extraction efficiency, linearity, and limits of detection (LOD), and has the capability of analyzing 320 to 960 samples per day. The strategic emphasis is on providing high-throughput LC/MS methods for evaluating large numbers of drug candidates during the discovery stage to eliminate poor pharmacokinetic performers.

Though n-in-one dosing formats provide a novel approach for high-throughput metabolism studies, these methodologies do not eliminate the potential of drug–drug interactions. Drug–drug interactions can have a significant impact on drug discovery programs and may lead to both false positives and false negatives (White, 2000). A modular approach for pharmacokinetic screening, referred to as cassette-accelerated rapid rat screen (CARRS), was developed by Korfmacher and colleagues (Korfmacher et al., 2001) to address

throughput and drug–drug interaction (see following section *In vitro* Drug Screening) issues. In this approach, one compound is dosed per animal. Two rats are used per drug candidate and plasma samples are collected at six time points, which results in a set of 12 rat plasma samples. The plasma samples are then pooled across time points for each rat resulting in a total of six pooled samples (i.e., one sample per time point). An abbreviated three-point calibration curve is used for each assay and run in duplicate, once before and once after the plasma samples. Figure 6.23 shows the sample arrangement (standards, blanks, and plasma samples) on a 96-well plate that results from this experiment for the analysis of six drug candidates. A standard HPLC gradient method is used for batch analysis of each plate. This systematic approach (i.e., standard methods, template structure identification) that features the assay of cassettes containing six drug candidates allows for the facile construction of a database for tracking the drug candidates. Table 6.7 shows the representative data obtained from 30 compounds using the CARRS approach.

In vitro Drug Screening

Alternative approaches that feature *in vitro* methodologies for drug screening have been incorporated into drug development schemes. Due to the wealth of samples resulting from high-throughput events

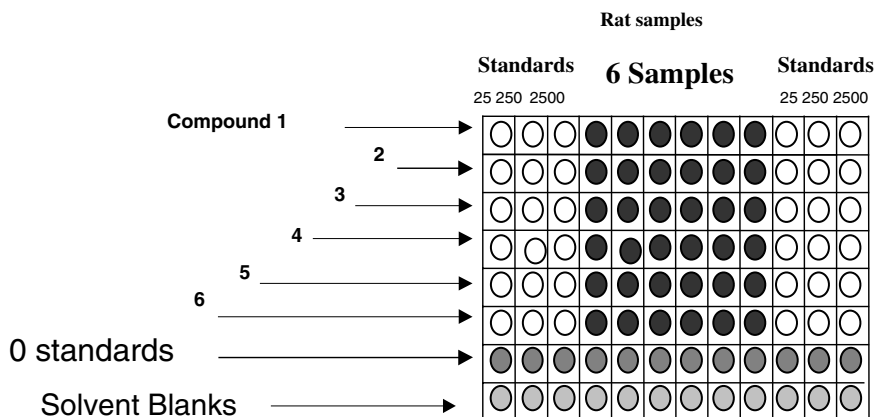

Figure 6.23 The arrangement of standards, samples, and solvent blanks for a CARRS assay using one 96-well plate for a batch of six compounds. (Reprinted with permission from Korfmacher et al., 2001. Copyright 2001 John Wiley & Sons.)

TABLE 6.7 Summary of the data obtained for 30 compounds screened using the CARRS assay^a

| Compound | Estimated AUC (0–6 hr) (ng/ml × hr) | Conc. @ 0.5 hr (ng/ml) | Conc. @ 1 hr (ng/ml) | Conc. @ 2 hr (ng/ml) | Conc. @ 3 hr (ng/ml) | Conc. @ 4 hr (ng/ml) | Conc. @ 6 hr (ng/ml) |
|----------|---|------------------------------|----------------------------|----------------------------|----------------------------|----------------------------|----------------------------|
| 1 | 9070 | 1900 | 1890 | 1660 | 1780 | 1400 | 1150 |
| 2 | 9030 | 1710 | 1990 | 2260 | 1620 | 1280 | 867 |
| 3 | 6810 | 1210 | 1320 | 1620 | 1340 | 946 | 833 |
| 4 | 5700 | 1590 | 1340 | 1300 | 1000 | 624 | 662 |
| 5 | 4375 | 1650 | 1260 | 797 | 662 | 525 | 356 |
| 6 | 4360 | 1260 | 1360 | 984 | 595 | 533 | 328 |
| 7 | 4140 | 1080 | 1320 | 925 | 645 | 497 | 296 |
| 8 | 4110 | 577 | 1070 | 935 | 637 | 669 | 452 |
| 9 | 3320 | 2080 | 1800 | 540 | 206 | 120 | 0 |
| 10 | 3310 | 649 | 929 | 743 | 564 | 442 | 318 |
| 11 | 2990 | 736 | 1050 | 597 | 522 | 355 | 179 |
| 12 | 2910 | 376 | 441 | 804 | 535 | 434 | 401 |
| 13 | 2870 | 1050 | 921 | 741 | 0 | 412 | 298 |
| 14 | 2780 | 490 | 685 | 667 | 427 | 440 | 270 |

| | | | | | | | |
|----|------|-----|------|-----|-----|-----|-----|
| 15 | 2700 | 922 | 1130 | 608 | 387 | 221 | 66 |
| 16 | 2600 | 413 | 542 | 674 | 433 | 443 | 221 |
| 17 | 2530 | 787 | 866 | 558 | 382 | 272 | 141 |
| 18 | 2410 | 690 | 691 | 458 | 392 | 338 | 188 |
| 19 | 1540 | 486 | 768 | 531 | 187 | 0 | 0 |
| 20 | 1000 | 215 | 289 | 212 | 151 | 139 | 106 |
| 21 | 976 | 213 | 252 | 192 | 155 | 141 | 122 |
| 22 | 886 | 433 | 397 | 194 | 70 | 43 | 45 |
| 23 | 784 | 859 | 326 | 86 | 23 | 0 | 0 |
| 24 | 611 | 181 | 180 | 121 | 95 | 80 | 49 |
| 25 | 463 | 450 | 238 | 38 | 21 | 0 | 0 |
| 26 | 333 | 41 | 44 | 52 | 56 | 77 | 58 |
| 27 | 100 | 65 | 23 | 13 | 11 | 10 | 11 |
| 28 | 19 | 24 | 10 | 0 | 0 | 0 | 0 |
| 29 | 0 | 0 | 0 | 0 | 0 | 0 | 0 |
| 30 | 0 | 0 | 0 | 0 | 0 | 0 | 0 |

Source: Reprinted with permission from Korfmacher et al., 2001. Copyright 2001 John Wiley & Sons.

^a Dose: PO 10 mg/kg in the rat.

such as combinatorial chemistry and cassette dosing strategies, in vitro methods provide a cost-effective solution. Detail is sacrificed so that approximate and/or relative values can be obtained with considerable savings in resources (i.e., instrumentation, animals) and time. In vitro drug screening methods do not necessarily replace in vivo approaches; however, these methods provide a streamlined way of focusing development efforts on a few lead candidate compounds from several hundred compounds.

Metabolic Stability Screening The use of fast gradient elution LC/MS techniques was described for high-throughput metabolic stability screening (Ackermann et al., 1998; Korfmacher et al., 1999). The method described by Ackermann uses a HPLC column-switching apparatus to desalt and analyze lead candidates incubated with human liver microsomes. Figure 6.24 illustrates the 12 overlaid selected ion monitoring (SIM) profiles acquired using a standard method for the test substrates spiked into blank human microsomal

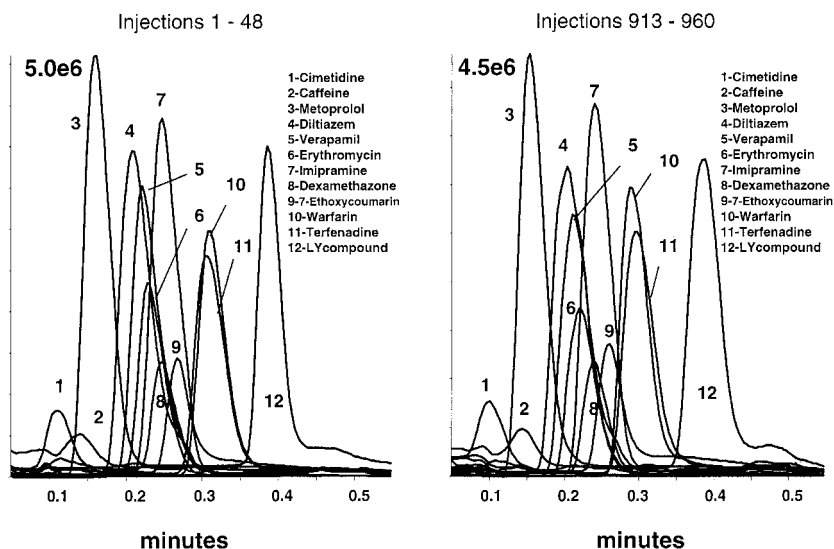

Figure 6.24 The SIM profiles of 12 lead candidates incubated with human liver microsomes, using a high throughput LC/MS system equipped with column switching to desalt and analyze the incubates. The reproducibility of the system over 960 injections is demonstrated. Analysis cycle time is approximately 0.5 min. (Ackermann et al., 1998.)

supernatant. These profiles show a favorable comparison among the series of substrates injected over a 12h period. Substrates were selected whose *in vivo* clearance is controlled predominantly by phase I oxidative metabolism as opposed to phase II metabolism or renal clearance. In this way, the resulting data could be resolved into four categories of metabolic stability: high ($\geq 60\%$); moderate ($\geq 30\text{--}59\%$); low ($\geq 10\text{--}29\%$); and very low ($< 10\%$).

Membrane Permeability LC/MS-based assays for screening drug candidates from the human colon adenocarcinoma cell line (Caco-2) have been described by Caldwell, Wang, Bu and colleagues (Caldwell et al., 1998; Wang et al., 2000; and Bu et al., 2000). Caco-2 models mimic drug transport across the intestinal epithelial cell barrier and are widely used as an *in vitro* model for oral drug absorption (Hilgers et al., 1990; Cogburn et al., 1991; Rubas et al., 1993; Wils et al., 1994; Walter et al., 1995; Yee, 1997). These *in vitro* models require sensitive and specific methods for the routine, high-throughput analysis of Caco-2 cell solutions.

The setup of this membrane permeability study involves the use of culture inserts that contain Caco-2 cells grown as epithelial layers. A drug candidate is delivered to the apical side of the cell monolayer (donor) and allowed to incubate for approximately 60 min. Samples from the apical and basolateral (recipient) side are collected for analysis by LC/MS/MS. Membrane permeability is expressed as the percentage of substrate transported across the monolayer from the apical to the basolateral side.

In the studies reported by Bu and colleagues (Bu et al., 2000), Caco-2 cell permeability of thirteen drugs with diverse physicochemical and pharmacological properties were rapidly assessed using LC/MS/MS. This LC/MS/MS screen features the use of a C_{18} guard column for direct injection of samples. An automated switching valve allows for efficient desalting and removal of endogenous materials prior to multiple reaction monitoring (MRM) analysis of the protonated molecular ion of the parent drug molecule and the corresponding product ion. Retention times were between 2.6 and 3.1 min and detection limits ranged from 1 to 30 nM. The lower limit of quantitation (LLOQ) was estimated to be between 10–20 nM for each compound tested. The apparent permeability coefficient (P_{app}) measured for the thirteen drugs are summarized in Table 6.8. The relative ranking of Caco-2 cell permeability for the drugs is

TABLE 6.8 Caco-2 cell permeability of the 13 drugs observed by 3 approaches

| Compound | DD | | | DP | | | CS | | |
|-----------------|------------|------------|------------|--------|--------|------------|--------|-----------|------------|
| | 3 Pooled | 4 Pooled | 5 Pooled | 3-in-1 | 4-in-1 | 5-in-1 | 3-in-1 | 4-in-1 | 5-in-1 |
| Acetophenetidin | 12.0 ± 1.4 | | 13.8 ± 2.4 | | | | | | |
| Chlorpromazine | 21.2 ± 2.0 | | 19.8 ± 3.1 | | | 20.8 ± 1.4 | | | 14.0 ± 2.1 |
| Diphenhydramine | 14.8 ± 0.1 | | 14 ± 0.9 | | | | | | 6.6 ± 0.6 |
| Fluconazole | 6.4 ± 0.9 | | 7.7 ± 0.5 | | | | | | 14.5 ± 2.2 |
| Haloperidol | 13.4 ± 1.2 | | 11.3 ± 2.0 | | | | | | |
| Imipramine | 10.5 ± 2.3 | 10.7 ± 2.1 | | | | | | 9.6 ± 2.7 | |
| Ketoconazole | 13.2 ± 2.2 | 12.5 ± 1.8 | | | | 13.1 ± 0.1 | | | |
| Orphenadrine | 10.5 ± 1.7 | | 12.1 ± 1.2 | | | | | 8.5 ± 0.3 | 10.1 ± 0.9 |
| Propafenone | 9.9 ± 0.3 | | 9.2 ± 0.1 | | | | | | 8.5 ± 0.2 |
| Propranolol | 8.8 ± 0.7 | 9.6 ± 0.5 | | | | | | | 12.1 ± 1.8 |
| Sulfaphenazole | 5.9 ± 0.7 | | | | | 4.8 ± 0.8 | | 5.1 ± 0.8 | |
| Testosterone | 6.7 ± 1.4 | 7.4 ± 1.7 | | | | | | | |
| Tolbutamide | 9.5 ± 0.6 | | | | | | | 8.3 ± 1.4 | |

Source: Reprinted with permission from Bu et al., 2000. Copyright 2000 John Wiley & Sons.

consistent with single drug dosing, sample pooling, and cassette dosing approaches.

Drug–Drug Interaction LC/MS-based screening approaches are used to evaluate the potential of drug–drug interactions either in vitro (Ayrton et al., 1998a; Bu et al., 2001) or in vivo (Frye et al., 1997; Scott et al., 1999). The strategy of these experiments is to obtain early indication of the inhibition or induction of the metabolism of compounds by the cytochrome P450 (CYP) isozymes. Specific CYP isozymes, typically those that are most commonly responsible for the metabolism of drugs, are studied because inhibition of CYP-mediated metabolism is often the mechanism for drug–drug interactions. These studies provide information on whether a drug may inhibit the biotransformation of another when the two are coadministered. LC/MS approaches are routinely used to identify/select drug candidates that have a lower potential for drug–drug interactions

Critical to the success of this screening approach is the selection and use of probe substrates that have a specific metabolic pathway mediated by a single CYP. An example of specific CYP probe substrates initially studied by Dear and co-workers (Ayrton et al., 1998a) is shown in Table 6.9. Many laboratories conduct detailed validation of CYP probe substrates to determine whether they can be simultaneously administered without metabolic interaction. One metabolic cocktail consists of the probe drugs caffeine, chlorzoxazone, dapsone, debrisoquin, and mephenytoin and is referred to as the *Pittsburgh cocktail* (Frye et al., 1997). The use of LC/MS/MS allows for the rapid

TABLE 6.9 Representative CYP450 probe substrates initially investigated at Glaxo Wellcome

| P450 | Substrate | Major Metabolite |
|----------|---------------|------------------------|
| 1A2 | Phenacetin | Paracetamol |
| 2A6 | Coumarin | 7-Hydroxycoumarin |
| 2C8/9/10 | Tolbutamide | 4-Hydroxytolbutamide |
| 2C19 | S-Mephenytoin | 4-Hydroxymephenytoin |
| 2D6 | Bufuralol | 1-Hydroxybufuralol |
| 2E1 | Chlorzoxazone | 6-Hydroxychlorzoxazone |
| 3A4 | Midazolam | 1-Hydroxymidazolam |

Source: Reprinted with permission from Ayrton et al., 1998a. Copyright 1998 John Wiley & Sons.

quantitation of the marker metabolites of the corresponding probe substrates. Due to the high volume of samples generated with this assay, LC/MS/MS methods for drug–drug interaction feature short analysis times with minimal sample preparation. The use of standard methods (Ayrton et al., 1998a) or direct injection techniques (Bu et al., 2001) eliminates the need for extensive method development and optimization.

The *in vitro* approaches feature human liver microsome incubations that contain drug candidates at a range of concentrations that span the anticipated maximum steady state plasma levels. The microsomal incubations also contain a specific probe substrate where the concentration closely approximates that K_m value for the reaction under investigation. Quantitative analysis of the specific marker metabolites and internal standards using MRM provides a simple assessment of the potential inhibitory effects drug candidates have on the metabolism of specific CYP probe substrates.

Metabolite Identification The rapid structure identification of metabolites during the drug discovery stage is a powerful complement to previously described quantitative approaches. Davis and co-workers demonstrated the utility of an automated metabolite identification approach using LC/MS/MS with an ion trap mass spectrometer to identify drug metabolites of the human immunodeficiency virus (HIV) protease inhibitor Indinavir (Lopez et al., 1998). In this study, metabolites of Indinavir were generated from *in vitro* incubation mixtures and automated MS^n analysis schemes provide maximum structural information in combination with predictive strategies for biotransformation. Automated data-dependent scan functions are used to generate full scan, MS/MS, and MS^n mass spectra of metabolites within a single chromatographic analysis. This feature is unique and avoids the multiple (2–4) injections that are necessary with other MS/MS configurations (e.g., tandem quadrupole). Along with the significant savings in time, detailed structure information is generated, which enables a comprehensive analysis of substructure relationship to be constructed for each metabolite. These automated studies provide unique advantages during drug discovery, and provide an early perspective on the metabolically labile sites, or soft spots of a drug candidate. This knowledge is useful during lead optimization activities and can lead to the initiation of proactive research efforts that deal with metabolism-guided structural modification and toxicity.

PRECLINICAL DEVELOPMENT

The transition from a lead candidate to investigational new drug/ clinical trial application (IND/CTA) represents the interface between drug discovery and preclinical development. With the focus on accelerated development timelines, the relationship between these two functions has become less distinct and less formal than in the past. Today, preclinical development activities are routinely initiated during the mid-to-late stages of drug discovery. The emphasis is primarily on the efficient transition of a novel bench-scale lead compound to bulk drug supplies suitable for testing on animals and humans.

Analysis Requirements. The previous section highlighted LC/MS-based analyses in support of drug discovery activities and featured fast and highly efficient methods. High throughput, specificity, and robust analysis characteristics were essential to meet the high sample volume (quantitative process) demands brought on by sample-generating technologies such as combinatorial chemistry and proteomics. In preclinical development activities, analyses are more dependent on *diversity of process* rather than the *diversity of samples*. This dependency is because preclinical development analyses typically require the measurement of a diverse number of analytes rather than a single or targeted analyte. Thus, an essential feature of preclinical development analyses is the ability to reliably monitor and identify components of interest, and to relate the information to the corresponding chemical or physiological process.

Traditional preclinical development analysis approaches involve the routine use of HPLC techniques. Preclinical development activities are typically slowed when HPLC retention times change and require authentic standards or the refinement of the chromatographic method to confirm identity. The use of LC/MS during this stage of drug development is far less dependent on the use of standards and provides reliable identification in situations where the retention times vary. Perhaps the most common type of structure identification activity during preclinical development involves the analysis of metabolites, impurities, and degradants. The early knowledge of structure allows for the quick refinement of the process directed toward improving a qualitative element of efficiency (i.e., yield, bioavailability, potency). Therefore, structure identification

plays a central role in prospective research, the acceleration of preclinical development activities, and filing of the IND/CTA.

Analysis Perspectives. Preclinical development is the first stage of the drug development cycle, where regulatory issues are formally addressed and validated methods are required. The transition from a regulatory-free environment in drug discovery presents some unique challenges for sample analysis activities. For example, issues that deal with the conversion of HPLC methods that employ phosphate buffers to methods that use volatile buffers, which are more suited for LC/MS, are common. Also, the evolutionary process of setting requirements and limits for impurities (i.e., specifications) is initiated based on analysis results for the IND/CTA. This stage of drug development involves pharmaceutical analysis activities directed toward the support of: (1) metabolism, (2) process research, (3) formulation, and (4) toxicology. These activities represent the first formal interaction between science and policy (i.e., regulatory compliance) within the drug development cycle.

LC/MS Contributions. LC/MS-based approaches have figured prominently in this stage of drug development. Bench-scale mixture analysis methodology is integrated into a single microscale on-line technique that is driven by the coordinated use of LC/MS and LC/MS/MS. Analysis strategies that emphasize an early lock-in of analytical methods provide a quick approach to begin support for a wide variety of analysis needs. This standard method feature is critical because method development and refinement activities are very time consuming and often delay the initiation of work.

The chromatographic separation affords a profile of components with reproducible relative retention time, whereas molecular weight is determined and structural information is collected via LC/MS and LC/MS/MS methods, respectively. A template motif for structure identification is used whereby the fragmentation pattern from the product ion spectrum of the parent drug is used to deduce the structures of the unknown metabolites, impurities, or degradants. Interpretation is systematic because specific product ions and neutral losses are correlated with specific substructures of the parent drug molecule. Structure databases are generated and provide a quick reference to proposed structure, relative retention time (RRT), molecular weight, and diagnostic functional groups. The databases provide a comprehensive approach to organizing structure information and the basis for comparison. In this way, LC/MS methods are used

TABLE 6.10 Representative applications of LC/MS in preclinical development

| Preclinical Development Activity | Analysis | LC/MS Application | Selected References |
|----------------------------------|---------------------------|---|---|
| Metabolism | Metabolite identification | Standard methods and databases | Kerns et al., 1997 |
| Process research | Impurity identification | Natural products; standard methods and databases | Kerns et al., 1994 |
| Formulation | Degradant identification | Predictive models for chemical degradants Predictive models for biomolecule degradants | Rourick et al., 1997 Kleintop et al., 1998 |

during the later stages of drug development to rapidly generate information in support of preclinical development and to provide valuable information in support of registration activities.

Overview. In this phase of drug development, the rapid structure identification of metabolites, impurities, and degradants is described during the preclinical development stage. The use of structure libraries that contain information on metabolic and chemical stability is illustrated during metabolism, chemical process research, formulation, and toxicology events. Consideration and approaches for method development, method lock-in, and specifications are highlighted for structure database assembly and technology transfer. Table 6.10 provides a summary of the LC/MS-based applications featured in this section.

Metabolite Identification

Metabolite identification is central to many of the activities in preclinical development. A more complete characterization of pharmacokinetic properties is performed in animals (typically rats and dogs) during this stage. The knowledge of the biotransformation pathways of the lead candidate to its metabolites is used to indicate the magnitude and duration of activity. Metabolite identification is critical to many of these activities and plays an important role in establishing the dose and toxicity levels.

The identification of metabolite structures with LC/MS and LC/MS/MS techniques are an effective approach due to their ability to analyze trace mixtures from complex samples of urine, bile, and plasma. The key to structure identification approaches is based on the fact that metabolites generally retain most of the core structure of the parent drug (Perchalski et al., 1982). Therefore, the parent drug and its corresponding metabolites would be expected to undergo similar fragmentations and to produce mass spectra that indicate major substructures.

Kerns and co-workers demonstrated the application of LC/MS and LC/MS/MS standard method approaches in preclinical development for the metabolite identification of buspirone, a widely used anxiolytic drug (Kerns et al., 1997). The success of this method relies on the performance of the LC/MS interface and the ability to generate abundant ions that correspond to the molecular weight of the drug and drug metabolites. The production of abundant molecular ions is an ideal situation for molecular weight confirmation because virtually all the ion current is consolidated into an adduct of the molecular ion (i.e., $[M+H]^+$, $[M+NH_3]^+$).

For example, full-scan mass spectra of buspirone contain an abundant $[M+H]^+$ ion signal with little detectable fragmentation. The product ion spectrum reveals product ions and neutral losses associated with diagnostic substructures of buspirone (Figure 6.25). The product ion at m/z 122, for example, is indicative of the pyrimidine substructure. The presence of this ion in the product ion spectrum of a metabolite indicates a structure that contains the pyrimidine substructure. Similarly, the m/z 180 product ion is diagnostic of the azaspirone decane substructure, and the neutral loss of 164 (producing the m/z 222 product ion) is diagnostic of the butyl azaspirone decane dione substructure.

To assist with the MS/MS structure identification, the gross substructure of buspirone is categorized into *profile groups* (Kerns et al., 1995). Profile groups directly correlate specific product ions and neutral losses with the presence, absence, substitution, and molecular connectivity (Lee et al., 1996) of specific buspirone substructures and their modifications. The profile groups of buspirone are identified with abbreviations that correspond to the three specific substructures: azaspirone decane dione (A), butyl piperazine (B), and pyrimidine (P). Substituted substructures are designated with a subscript (\S), and a dash (–) denotes substructure connectivity. Thus, the buspirone molecule is represented by A-B-P. The A_{\S} -B-P designation

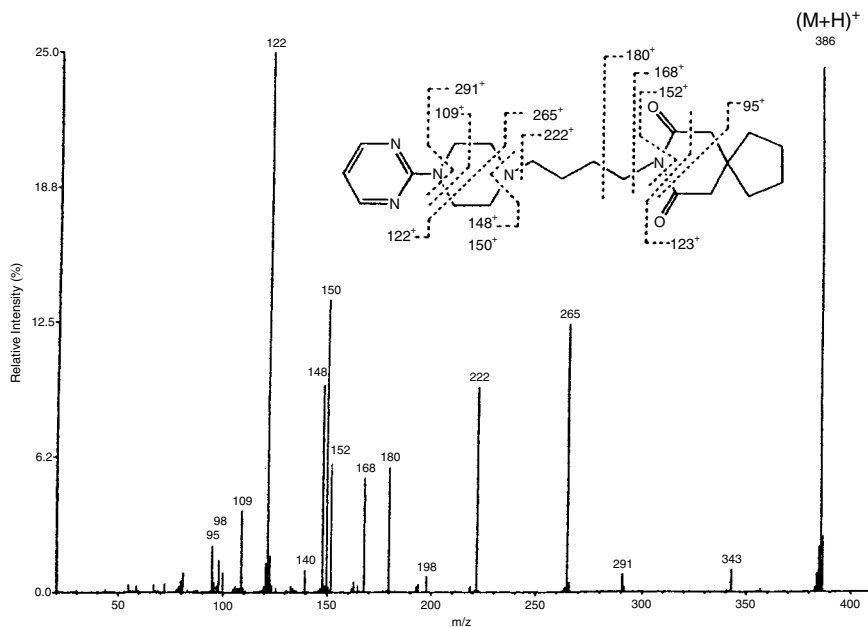

Figure 6.25 Product ion spectrum of the $[M+H]^+$ of buspirone, and the correspondence of ions to specific substructures that are diagnostic of the compound and are used as a template for structure identification of buspirone metabolites. (Reprinted with permission from Kerns et al., 1997. Copyright 1997 Elsevier.)

refers to metabolite structures that contain the azaspirone decane dione, butyl piperazine, and pyrimidine substructures with substitution on the azaspirone decane dione substructure. The profile group categorization within a corresponding database allows the rapid visual recognition of primary substructures affected by metabolism.

Table 6.11 illustrates a representative buspirone metabolite structure database. Information on the structure, molecular weight, UV characteristics, RRT, and product ions of metabolites obtained from rat bile, urine, and liver S9 samples are compiled. Using this format, the predominant buspirone metabolite profile groups, A_s -B-P, A-B- P_s , and A_s -B- P_s are easily recognized. These profile groups indicate azaspirone decane dione and pyrimidine as metabolically active sites of attack and the presence of multiple substitution sites on each of these substructures. In many cases, the profile groups indicate the occurrence of metabolic reactions on more than one substructure.

Table 6.12 summarizes the product ion spectra obtained for each

TABLE 6.11 Buspirone metabolite database of structures identified with LC/MS and LC/MS/MS with a standard method

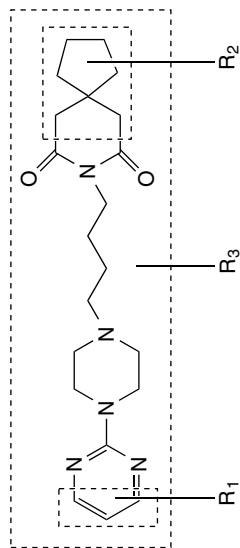

| Proposed Structure | No. | t_{RR}^a | MH ^{±b} | Profile Group ^c | R ₁ ^d | R ₂ ^d | R ₃ ^d | Sample Source ^e |
|---------------------------------------|-----|------------|------------------|----------------------------------|-----------------------------|-----------------------------|-----------------------------|----------------------------|
| Hydroxy buspirone glucuronide | 1 | 0.14 | 594 | A _s -B-P _s | +OH | +OH | +Glucoronyl | B |
| Hydroxy buspirone glucuronide | 2 | 0.30 | 594 | A _s -B-P _s | +OH | +OH | +Glucoronyl | B |
| Hydroxy buspirone glucuronide | 3 | 0.35 | 594 | A _s -B-P _s | +OH | +OH | +Glucoronyl | B |
| Hydroxy methoxy buspirone glucuronide | 4 | 0.36 | 624 | A _s -B-P _s | +OH, +OCH ₃ | +OH | +Glucoronyl | B |
| Hydroxy methoxy buspirone glucuronide | 5 | 0.38 | 624 | A _s -B-P _s | +OH, +OCH ₃ | +OH | +Glucoronyl | B |
| Hydroxy buspirone glucuronide | 6 | 0.38 | 594 | A _s -B-P _s | +OH | +OH | +Glucoronyl | B |
| 1-Pyrimidinyl piperazine | 7 | 0.42 | 165 | B _s -P | U | N | | S9 |
| Buspirone glucuronide | 8 | 0.44 | 578 | A-B-P _s | +OH, +Glucoronyl | | | B |

| | | | | | | | | |
|-------------------------------------|----|------|-----|----------------------------------|------------------------|--------|-----------------------------------|-----------|
| Dihydroxy buspirone | 9 | 0.45 | 418 | A _s -B-P | U | +2(OH) | Ur, S9 | B |
| Methoxy buspirone glucuronide | 10 | 0.46 | 608 | A-B-P _s | +OH, +OCH ₃ | | +Glucuronyl | |
| Dihydroxy buspirone | 11 | 0.48 | 418 | A _s -B-P | U | -2(OH) | Ur, S9 | Ur, S9 |
| Dihydroxy buspirone | 12 | 0.48 | 418 | A _s -B-P _s | +OH | +OH | | B, S9 |
| Despyrimidinyl piperazine buspirone | 13 | 0.50 | 254 | A-B _s | N | U | -Pyrimidinyl piperazine, +=O, +OH | |
| Dihydroxy methoxy buspirone | 14 | 0.51 | 448 | A _s -B-P _s | +OH, +OCH ₃ | +OH | | Ur |
| Hydroxy buspirone | 15 | 0.53 | 402 | A _s -B-P | U | +OH | | B, Ur, S9 |
| Dihydroxy buspirone | 16 | 0.55 | 418 | A _s -B-P | U | +2(OH) | | Ur |
| Dihydroxy buspirone | 17 | 0.55 | 418 | A _s -B-P | U | +2(OH) | | Ur |
| Dihydroxy buspirone | 18 | 0.56 | 418 | A _s -B-P | U | | +2(OH) | B |
| Hydroxy buspirone | 19 | 0.59 | 402 | A _s -B-P | U | +OH | | Ur, B, S9 |
| Hydroxy buspirone | 20 | 0.69 | 402 | A _s -B-P | U | +OH | | Ur, B, S9 |
| Dihydroxy buspirone | 21 | 0.70 | 418 | A _s -B-P _s | +OH | +OH | | Ur, S9 |
| Despyrimidinyl buspirone | 22 | 0.74 | 308 | A-B _s | | | -Pyrimidine | B |
| Hydroxy buspirone | 23 | 0.74 | 402 | A _s -B-P | U | +OH | | B |
| Hydroxy buspirone | 24 | 0.80 | 402 | A _s -B-P | U | +OH | | B, Ur |
| Hydroxy buspirone | 25 | 0.87 | 402 | A-B-P _s | +OH | U | | Ur, S9 |
| Buspirone | 26 | 1.00 | 386 | A-B-P | U | U | | B, Ur, S9 |

Source: Reprinted with permission from Kerns et al., 1997. Copyright 1997 Elsevier.

^a HPLC retention time relative to buspirone ($t_{RR} = 1.00$) using universal HPLC conditions. Buspirone retention time was 13.5 min.

^b Molecular mass.

^c Refer to text for discussion of profile group categorization. A = azaspirone decane dione, B = butyl piperazine, P = pyrimidine, subscript s refers to substitution in a particular substructure, NA = not available from the data.

^d U = unchanged substructure, N = substructure not present.

^e Sample source: B = rat bile in vivo, Ur = rat urine, S9 = rat liver S9 preparation in vitro.

TABLE 6.12 Production spectra of (M + H)⁺ ions of buspirone metabolites and their structural interpretation based on buspirone as a structural template

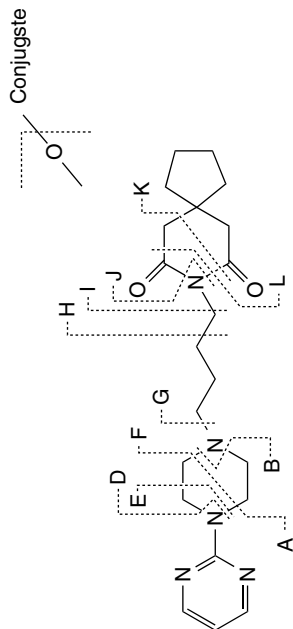

| Proposed Structure | Fragmentation; <i>m/z</i> | | | | | | | | | | | | | | | | |
|-------------------------------|---------------------------|------------------------|-----------------|-----|-----|---|-----|---|-----|-----|-----|-----|-----|-----|-----|-----|--------|
| | No. | <i>t</i> _{RR} | MH ⁺ | A | B | C | D | E | F | G | H | I | J | K | L | M | Others |
| Hydroxy buspirone glucuronide | 1 | 0.14 | 594 | 138 | | | | | | | | | | | | 418 | 98 |
| Hydroxy buspirone glucuronide | 2 | 0.30 | 594 | 138 | | | | | | 238 | | | | | | 418 | 98 |
| Hydroxy buspirone glucuronide | 3 | 0.35 | 594 | 138 | 166 | | | | | 281 | 238 | | | | | 418 | 98 |
| Hydroxy methoxy buspirone | 4 | 0.36 | 624 | 168 | | | | | | 238 | | | | 139 | 448 | | |
| Hydroxy methoxy buspirone | 5 | 0.38 | 624 | 168 | | | | | | | | | | 139 | 448 | | |
| Hydroxy buspirone glucuronide | 6 | 0.38 | 594 | 138 | 166 | | | | 281 | | | | | | | 418 | |
| 1-Pyrimidinyl piperazine | 7 | 0.42 | 165 | | | | | | | | | | | | | | |
| Buspirone glucuronide | 8 | 0.44 | 578 | 138 | 164 | | | | 265 | 222 | 180 | 168 | 152 | 123 | 402 | 109 | |
| | | | | | 166 | | | | | | | | | | | | |
| Dihydroxy buspirone | 9 | 0.45 | 418 | 122 | 148 | | 323 | | 297 | 254 | | | | | | | |
| | | | | | 150 | | | | | | | | | | | | |

| | | | | | | | | | | |
|--|----|------|-----|-----|-----|-----|-----|-----|----------|--|
| Methoxy buspirone glucuronide | 10 | 0.46 | 608 | 168 | 196 | | 265 | 168 | 432 | 100 |
| Dihydroxy buspirone | 11 | 0.48 | 418 | 122 | 148 | 323 | 297 | 254 | | |
| Dihydroxy buspirone | 12 | 0.48 | 418 | 138 | 166 | | 281 | 238 | 151, 152 | 95 123 |
| Despyrimidinyl piperazine buspirone | 13 | 0.50 | 254 | | | | | | | 236, 208, 194, 109, 86, 81 383, 121, 100 98 |
| Dihydroxy methoxy buspirone | 14 | 0.51 | 448 | 169 | 194 | | 281 | 238 | 139 | |
| Hydroxy buspirone | 15 | 0.53 | 402 | 122 | 148 | | 281 | 238 | 95 | |
| Dihydroxy buspirone | 16 | 0.55 | 418 | 122 | 148 | 177 | 281 | 238 | 139 | 400, 306, 293, 267, 98 |
| Dihydroxy buspirone | 17 | 0.55 | 418 | | | | 297 | 238 | 95 | 139 |
| Dihydroxy buspirone | 18 | 0.56 | 418 | 122 | 150 | | | | | 98 |
| Hydroxy buspirone | 19 | 0.59 | 402 | 122 | 148 | | 281 | 238 | | 219, 192, 178, 98 |
| Hydroxy buspirone | 20 | 0.69 | 402 | 122 | 148 | 177 | 265 | 222 | 180 | 168 152 |
| Dihydroxy buspirone | 21 | 0.70 | 418 | 138 | 164 | | 281 | 238 | 139 | 400 |
| Despyrimidinyl buspirone | 22 | 0.74 | 308 | | | | 222 | 180 | 168 | 152 |
| Hydroxy buspirone | 23 | 0.74 | 402 | 122 | 148 | 307 | 281 | 238 | 95 | 139 |
| Hydroxy buspirone | 24 | 0.80 | 402 | 122 | 148 | 307 | 281 | 238 | 168 | 139 |
| Hydroxy buspirone | 25 | 0.87 | 402 | 138 | 166 | | 265 | 222 | 180 | 168 152 |
| Buspirone | 26 | 1.00 | 386 | 122 | 148 | 291 | 109 | 265 | 222 | 180 168 152 |
| | | | | | 150 | | | | | 98 |

Source: Reprinted with permission from Kerns et al., 1997. Copyright 1997 Elsevier.

buspirone metabolite structure. In combination with the data in Table 6.11, these results provide a comprehensive metabolite structure database that is indexed by specific analytical characteristics. This database is a useful source of information for accelerated pre-clinical development activities. It provides a useful tool for the rapid dereplication of metabolites observed in previous drug discovery studies and serves as a future reference for the identification of novel structures during the clinical stages of drug development. This protocol has also been found to be useful during drug discovery research for chemistry, metabolism, pharmacokinetics, activity, and safety studies (Lee et al., 1997). Extensions of this approach with microprobe NMR analysis of a 50 μg sample of isolated metabolite are routinely performed (Rourick et al., unpublished data, 1997). A chemical shift template characteristic of unique substructural sites is used to identify specific structural modifications and to distinguish isomers.

Impurity Identification

Synthetic impurities are of particular concern during process research and safety evaluation activities. Often, impurities are the result of synthetic by-products or starting materials of the scale-up process. Impurities provide a comprehensive indicator of the chemical process and are diagnostic of overall quality. Process chemists use the resulting information to guide process optimization. Knowledge of the identity and relative amount of impurities is used to diagnose process reactions so that changes in reagents and reaction conditions lead to better yields and higher quality material. Although it is often difficult to assign an exact time period for the completion of chemical process research activities, it is usually the rate-determining step for preclinical development activities.

With an increasing number of novel lead candidates that enter into preclinical development, considerable resources are needed to identify impurities. LC/MS-based approaches provide integrated sample cleanup and structure analysis procedures for the rapid analysis of impurities. This advantage was demonstrated during the preclinical development of TAXOL[®]. LC/MS played an important role for the identification of impurities contained in extracts and process intermediates from *Taxus brevifolia* and *T. baccata* biomass. Because drugs derived from natural sources often have a very diverse set of structural analogs, it is important to determine which

analogs are carried through the purification process and ultimately appear as impurities. This task presents a unique challenge during the preclinical stage of drug development due to the highly complex nature of the samples.

Similar to the approaches described previously for natural products dereplication during drug discovery, traditional strategies for impurity identification rely on scale-up, extraction, isolation, and detailed structure analysis. Unfortunately, these methods are slow, time-consuming, and problematic for accelerated preclinical development activities. Rapid structure identification methods that use LC/MS and LC/MS/MS protocols are ideal for handling large numbers of drug candidates and are applicable to a diverse range of compound classes. Furthermore, the sensitivity of LC/MS-based methods is sufficient to study impurities and active compounds at extremely low levels (0.2–2 nmol).

Kerns and co-workers developed a structure identification strategy that incorporates LC/MS and LC/MS/MS techniques for rapid, sensitive, and high-throughput impurity analysis (Kerns et al., 1994). This approach integrates traditional steps of sample preparation, separation, analysis, and data management into a single instrumental method. The resulting multidimensional data include retention time, molecular weight, UV, and substructure information. A structure database is developed for each candidate and is used to rapidly identify the same impurities in new samples. Structures are proposed based on using the drug candidate as a structural template and, with the use of a standard method approach, consistency for comparison of results throughout the preclinical development process is ensured.

The full-scan mass spectrum of paclitaxel is shown in Figure 6.26. The spectrum contains abundant molecular ions at m/z 854, 871, and 912, which correspond to $[M+H]^+$, $[M+NH_4]^+$, and $[M+NH_4+CH_3CN]^+$, respectively. This distinct molecular ion pattern is used to determine the molecular weight of the resulting impurities. The product ion spectrum of the $[M+NH_4]^+$ ion of paclitaxel is shown in Figure 6.27. Abundant product ions are present in the spectrum and correspond to unique substructures that are diagnostic of paclitaxel. Perhaps most strategic are the product ions associated with the paclitaxel core substructure (m/z 569) and side chain (m/z 286). This unique pair of product ions serves as a diagnostic reference to structure. Once the product ions are assigned to their corresponding paclitaxel substructure, the spectrum is used as a substructural template for the identification of impurities.

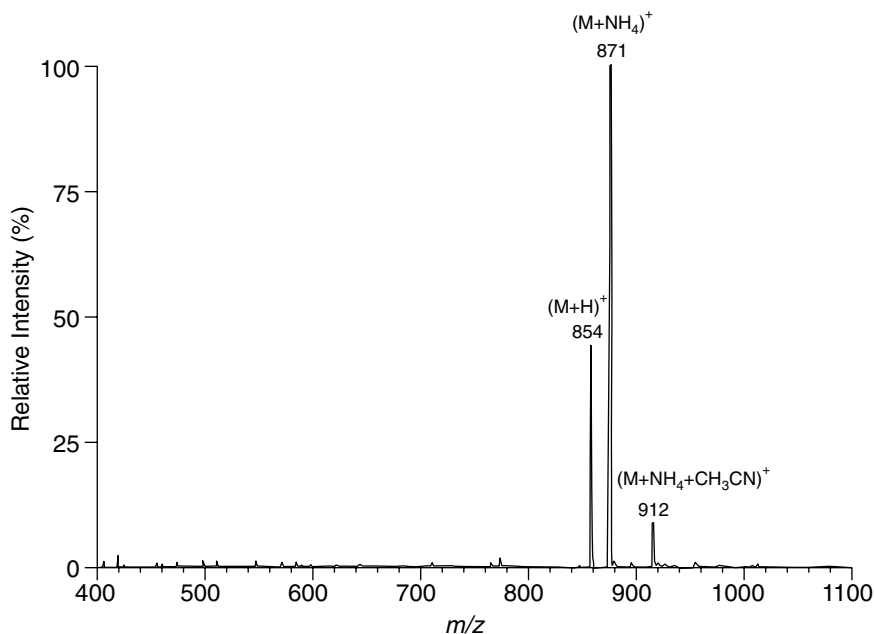

Figure 6.26 ESI full-scan mass spectrum of paclitaxel with a mobile phase that contains aqueous 2mM ammonium acetate and acetonitrile. (Reprinted with permission from Kerns et al., 1994. Copyright 1994 American Chemical Society.)

A representative HPLC chromatogram with UV detection (230nm) of a process penultimate lot of paclitaxel from *T. brevifolia* bark is shown in Figure 6.28A. A comparable LC/MS-TIC chromatogram of the sample, obtained simultaneously with the LC/UV profile, is shown in Figure 6.28B. The responses in each chromatogram compare favorably with each other. The molecular weight of each component is obtained on-line from the full-scan mass spectrum at a specific retention time. The sample is again subjected to HPLC separation and a product ion spectrum is obtained for each compound. Structures of impurities are proposed based on a comparison of the molecular weight, product ions, and neutral losses associated with paclitaxel.

Table 6.13 summarizes the novel taxane structures identified with LC/MS. These impurities incorporate several consistent structural variations from the five profile groups of paclitaxel (Figure 6.29). Nearly all of the compounds contain the characteristic paclitaxel

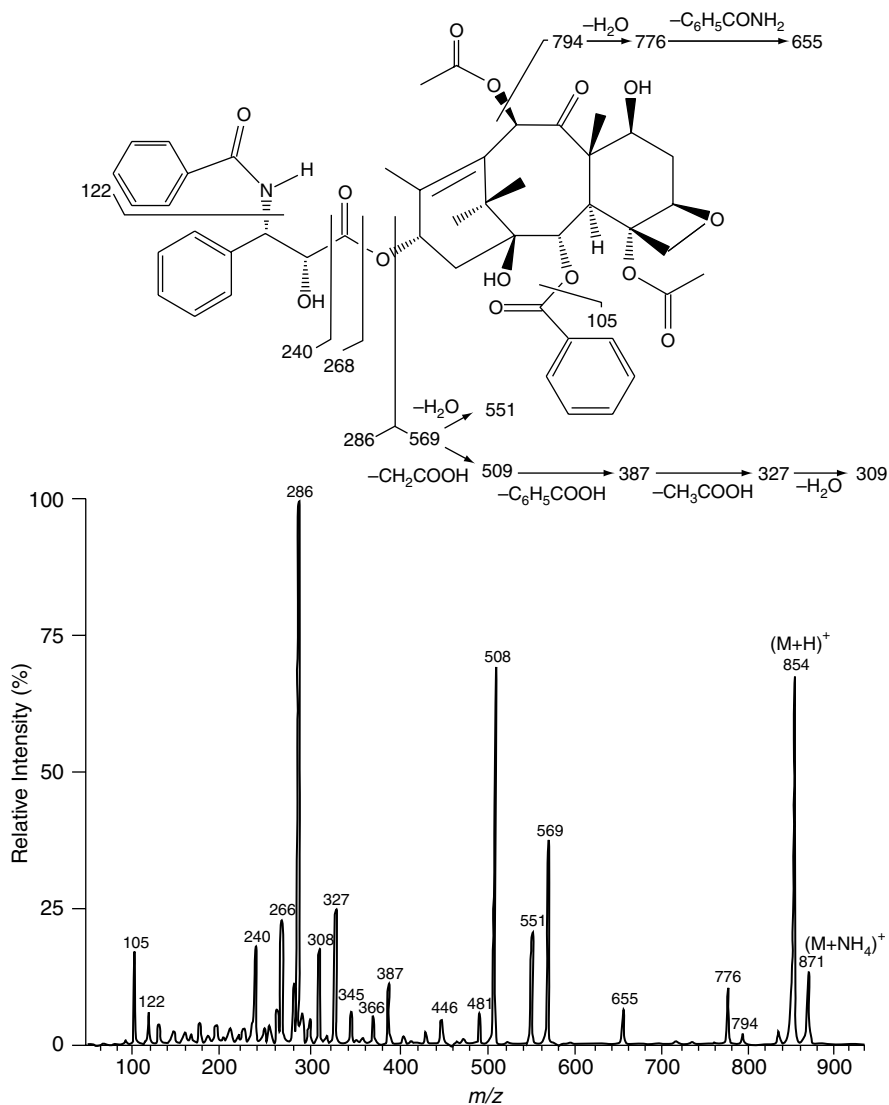

Figure 6.27 Product ion spectrum of the $[M+NH_4]^+$ ion of paclitaxel and correspondence of ions to specific substructures diagnostic of the compound, used as a template for structure identification of paclitaxel impurities. (Reprinted with permission from Kerns et al., 1994. Copyright 1994 American Chemical Society.)

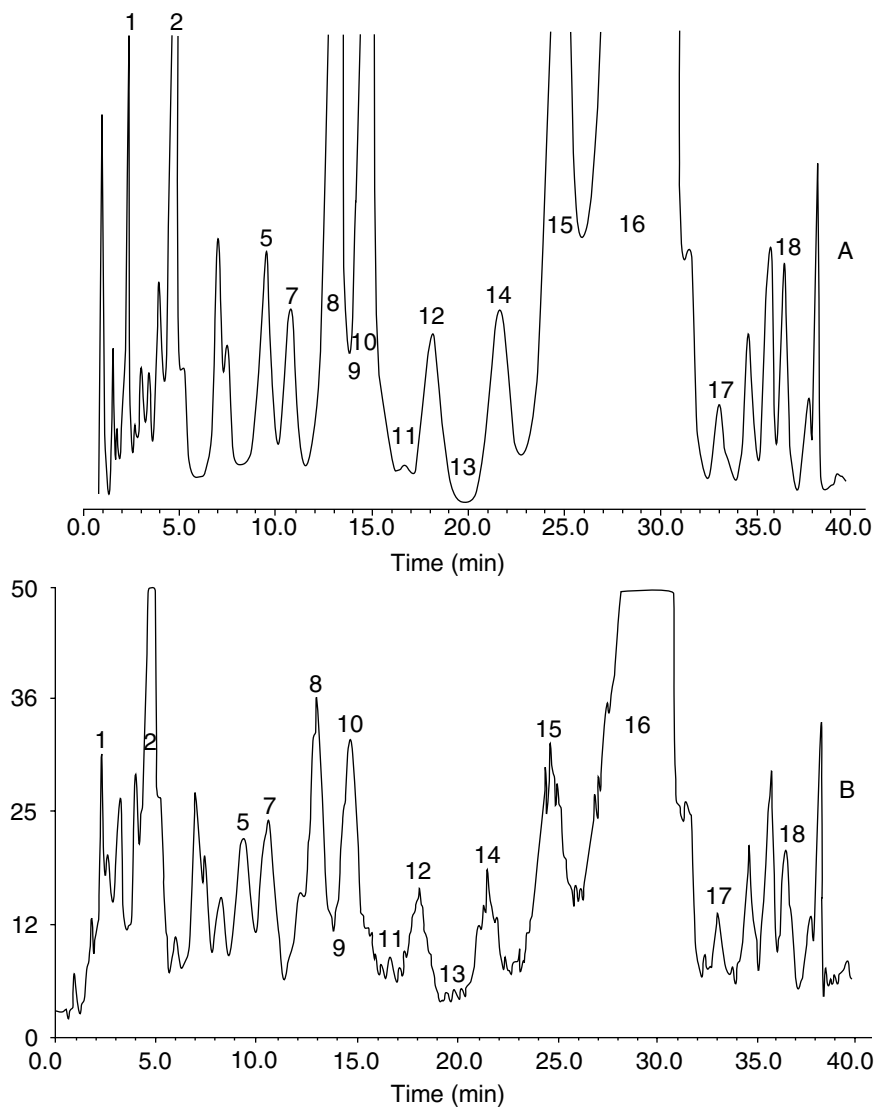

Figure 6.28 HPLC chromatograms of a process penultimate lot of paclitaxel from *T. brevifolia* bark. (A) LC/UV (230nm) chromatogram. (B) LC/MS full scan TIC chromatogram. (Reprinted with permission from Kerns et al., 1994. Copyright 1994 American Chemical Society.)

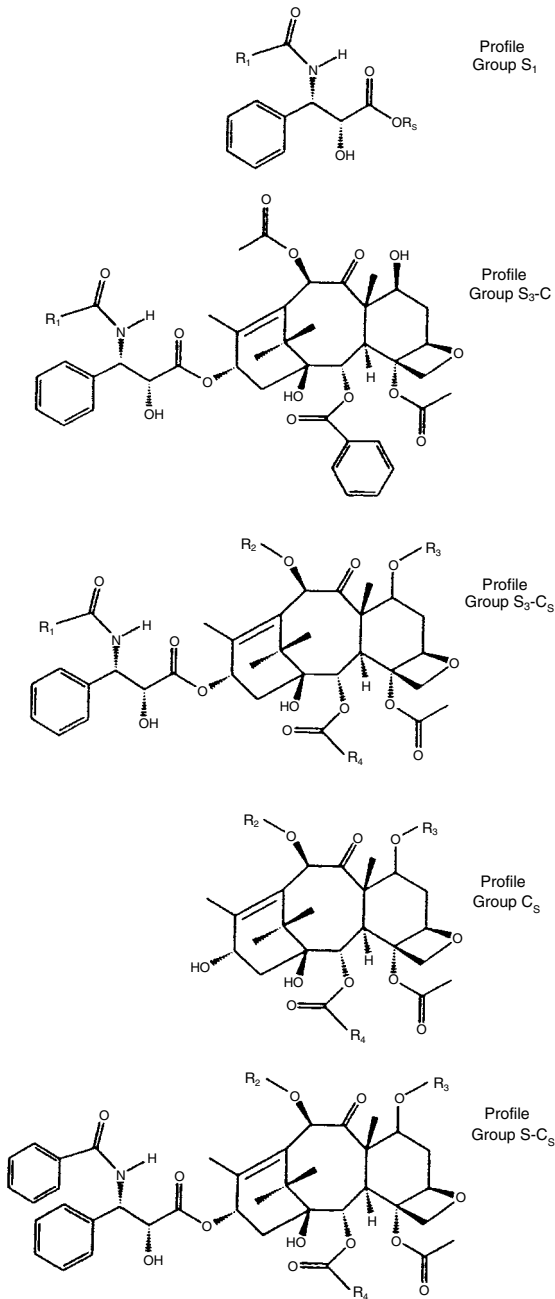

Figure 6.29 General structures of the five profile groups observed using LC/MS, based on the paclitaxel template. (Reprinted with permission from Kerns et al., 1995. Copyright 1995 John Wiley & Sons.)

TABLE 6.13 Novel taxane structures and related derivatives identified by using paclitaxel as a structural template

| Proposed Structure | RR_t^a | Mol. Wt. ^b | Profile Group ^c | R_1^d | R_2^d | R_3^d | R_4^d | R_5^d | Sample Source ^e |
|--|----------------|-----------------------|--------------------------------|---|--------------------|----------|---|-------------------------------|----------------------------|
| Paclitaxel side chain methyl ester | 0.17 | 299 | S ₁ | C ₆ H ₅ | — | — | — | CH ₃ | ix |
| Paclitaxel side chain ethyl ester ^f | 0.18 | 313 | S ₁ | C ₆ H ₅ | — | — | — | C ₂ H ₅ | v |
| 10-Deacetyl propyl paclitaxel analog | 0.24 [1.61] | 777 | S ₃ —C _s | C ₃ H ₇ | H | H | C ₆ H ₅ | — | ii, vii |
| Methyl paclitaxel analog | 0.25 | 791 | S ₃ —C | CH ₃ | CH ₃ CO | H | C ₆ H ₆ | — | i |
| 7-Xyloxy-10-deacetyl benzyl paclitaxel analog | 0.32 | 957 | S ₃ —C _s | C ₆ H ₅ CH ₂ | H | β-Xylose | C ₆ H ₅ | — | vii |
| Ethyl paclitaxel analog ^g | 0.36 | 805 | S ₃ —C | C ₂ H ₅ | CH ₃ CO | H | C ₆ H ₅ | — | i |
| 10-Deacetyl benzyl paclitaxel analog | 0.48 | 825 | S ₃ —C _s | C ₆ H ₅ CH ₂ | H | H | C ₆ H ₅ | — | viii |
| 7-Xyloxy-10-deacetyl hexyl paclitaxel analog | 0.51 | 951 | S ₃ —C _s | C ₆ H ₁₃ | H | β-Xylose | C ₆ H ₅ | — | vii |
| n-Propyl paclitaxel analog ^{g,s} | 0.52 | 819 | S ₃ —C | C ₃ H ₇ | CH ₃ CO | H | C ₆ H ₅ | — | iii, i |
| 7-Xyloxy benzyl paclitaxel analog | 0.53 | 999 | S ₃ —C _s | C ₆ H ₅ CH ₂ | CH ₃ CO | β-Xylose | C ₆ H ₅ | — | vi |
| 10-Deacetyl taxol C | 0.56 [1.84] | 805 | S ₃ —C _s | C ₅ H ₁₁ | H | H | C ₆ H ₅ | — | ii, vii, viii |
| 10-Deacetyl-7- <i>epi</i> -cephalomannine | 0.60 | 789 | S ₃ —C _s | C ₄ H ₇ | H | H | C ₆ H ₅ | — | i |
| Debenzoyl pentenoate paclitaxel analog | 0.70 | 831 | S ₃ —C _s | C ₆ H ₅ | CH ₃ CO | H | CH ₃ C=CH ₂ CH ₃ | — | iv |
| Butyl paclitaxel analog | 0.75 | 833 | S ₃ —C | C ₄ H ₉ | CH ₃ CO | H | C ₆ H ₅ | — | i |
| 10-Deacetyl-7- <i>epi</i> -taxol C | 1.00 | 805 | S ₃ —C _s | C ₅ H ₁₁ | H | H | C ₆ H ₅ | — | i |

| | | | | | | | | | |
|--|--------|-----|--------------------------------|---|--------------------|---|---|---|--------|
| n-Propyl- <i>epi</i> -paclitaxel analog | 1.01 | 819 | S ₃ —C _s | C ₃ H ₇ | CH ₃ CO | H | C ₆ H ₅ | — | i |
| Benzyl paclitaxel analog | 1.05 | 867 | S ₃ —C | C ₆ H ₅ CH ₂ | CH ₃ CO | H | C ₆ H ₅ | — | i, iii |
| 7- <i>epi</i> -Cephalomannine/7- <i>epi</i> -Butyl paclitaxel analog | 1.10 | 831 | S ₃ —C _s | C ₄ H ₇ | CH ₃ CO | H | C ₆ H ₅ | — | i, iii |
| | 1.12 | 833 | S ₃ —C _s | C ₄ H ₉ | CH ₃ CO | H | C ₆ H ₅ | — | ix |
| Hexyl paclitaxel analog | 1.15 | 861 | S ₃ —C | C ₆ H ₁₃ | CH ₃ CO | H | C ₆ H ₅ | — | i, iii |
| 7- <i>epi</i> -Taxol C | 1.21 | 847 | S ₃ —C _s | C ₃ H ₁₁ | CH ₃ CO | H | C ₆ H ₅ | — | i |
| Hydroxy-10-deacetyl baccatin III | [0.75] | 560 | C _s | — | H | H | C ₆ H ₅ | — | ii |
| Debenzoyl-10-deacetyl baccatin III | [0.82] | 522 | C _s | — | H | H | C ₄ H ₇ | — | ii |
| pentenoate | | | | | | | | | |
| Debenzoyl-10-deacetyl baccatin III phenylacetate | [1.16] | 558 | C _s | — | H | H | C ₆ H ₅ CH ₂ | — | ii |
| 10-Deacetyl baccatin III hydroxybutyrate | [1.25] | 630 | C _s | — | H | H | C ₃ H ₆ OH | — | ii |
| 10-Deacetyl ethyl paclitaxel | [1.51] | 763 | S ₃ —C _s | C ₂ H ₅ | H | H | C ₆ H ₅ | — | ii |

Source: Reprinted with permission from Kerns et al., 1994. Copyright 1994 American Chemical Society.

^a HPLC retention time relative to paclitaxel (RRT = 1.00) using HPLC condition I or condition II.

^b Molecular weight.

^c Refer to text for categorization. S = paclitaxel side chain substructure; C = paclitaxel core substructure; subscripts 1 and 3 refer to the position of substitution and subscript s refers to a general position of substitution on the respective substructure.

^d Refer to Fig. 1 for the general structures including R groups. For paclitaxel, R₁ = C₆H₅, R₂ = CH₃CO, R₃ = H and R₄ = C₆H₅.

^e Sample source: i, Impurities in paclitaxel prepared from *Taxus brevifolia*. ii, Impurities in 10-deacetyl baccatin III purified from *T. baccata*. iii, Impurities in paclitaxel from *T. hicksii*. iv, Impurities in semisynthetic paclitaxel. v, Paclitaxel heated with ethanol for 12 weeks at 50 °C. vi, Impurities in preparations of 10-xylosyl paclitaxel purified from *T. brevifolia*. vii, Impurities in preparations of 10-deacetyl xylosyl paclitaxel from *T. brevifolia*. viii, Impurities in preparations of 10-deacetyl paclitaxel from *T. brevifolia*. ix, Paclitaxel treated with Na₂CO₃ (0.05 M) for 10 min at pH 8 and diluted in methanol.

^f Confirmed using authentic standard with the result of matching RRT, MW, and MS/MS product ion spectrum.

^g Recently reported.

core substructure as indicated by the product ion at m/z 509 with variations due to modifications. Many of these taxanes contain a side chain similar to paclitaxel, with variations occurring on the terminal amide of the side chain. The product ions that differ from the characteristic side chain ions of paclitaxel (m/z 286) by values indicative of specific substructures demonstrate these terminal amide variations. A comparison with the paclitaxel substructural template indicates structural differences beyond the position of the amide group in the side chain substructure.

When a new impurity is encountered during chemical process research, retention time and molecular weight information are compared to the database for rapid identification. This approach is similar to the procedure described for natural product dereplication. If the compound is not contained in the structure database, then the corresponding LC/MS/MS analysis is performed to obtain substructural detail and the proposal of a new structure.

Minimal sample preparation (dilution in HPLC mobile phase) is necessary. A standard reversed-phase HPLC method is used for all the samples associated with a drug candidate to reduce time-consuming method development/method refinement procedures. Standard reversed-phase methods typically involve a 20–30 min cycle time and provide information on a wide range of compounds. The incorporation of a standard method strategy allows the use of autosampling procedures and standard system software for data analysis.

During the development of TAXOL[®], 90 taxane impurities were rapidly identified and added to the structure database. This MS/MS information is routinely obtained for impurities down to the 100 ng level (injected), and requires approximately 2–3 h for the analysis of each sample. The compounds are structurally categorized with profile group terminology. The LC/MS-based methods are significantly faster than previous methods based on scale-up, isolation, fractionation, and individual structural analysis.

Degradant Identification

The proactive characterization and identification of degradants during the preclinical development phase of drug development offer advantages in the evaluation of drug candidates and their subsequent performance during clinical trials. The early knowledge of degradants provides insight into stability and toxicity. The value

of early knowledge of degradants is to provide insights into critical issues and the development of corrective measures *prior* to clinical trials.

During the course of drug development, the bulk drug and drug formulation are studied under a variety of stress conditions such as temperature, humidity, acidity, basicity, oxidization, and light. Qin and colleagues described the use of stressing conditions that may cause degradation (Qin et al., 1994). The resulting samples may be used to validate analytical monitoring methods and to serve as predictive tools for future formulation and packaging studies.

A traditional approach to studying degradant formation involves similar time-consuming scale-up and preparation steps as described for metabolite and impurity analysis. Similarly, this area of pharmaceutical analysis has experienced the issues associated with faster drug development cycles. Rourick and co-workers described proactive approaches to obtain degradant information with LC/MS methods during the preclinical development stage (Rourick et al., 1996). The procedure incorporates qualitative and quantitative process changes for analysis. The structural information necessary for successful drug development is emphasized. The corresponding structural information provides insight for decisions, based on which leads are to be developed for clinical testing. The early structural information on degradants of a drug candidate offers a unique capability for synthetic modification to minimize degradation. Structural information can also facilitate planning of preclinical drug development in process research, formulation development, and safety assessment.

The strategy for impurity and degradant identification described by Rourick and co-workers (Rourick et al., 1996) subjects lead candidates to various development conditions, followed by LC/MS and LC/MS/MS analysis protocols. A structure database is constructed from the corresponding results and is used to reveal unstable regions within the drug structure as well as to ascertain which candidate or homologous series of drug candidates may be the most favorable for further development. High capacity, throughput, and speed are necessary so that many lead candidates may be evaluated. Applicability of the method to a wide range of compound classes is desirable. Once the drug candidate enters clinical development and manufacturing, the structure database is useful for the rapid identification of impurities and degradants in samples generated during these stages of development.

The method exposes drug candidates to forced degradation conditions (e.g., acid, base, heat, and moisture) as a *predictive profile*. The coordinated use of LC/MS and LC/MS/MS provides structure identification for speed, sensitivity, and high throughput. Standard methods, useful for 80% of the compounds, are applied. Various types of structural data are obtained for elucidation purposes (e.g., retention time, molecular weight, MS/MS), and unknown compounds are elucidated with the candidate drug as a structural template. The LC/MS analysis provides retention time and molecular weight data, whereas LC/MS/MS provides substructural detail for structure identification purposes. Drug candidates are incubated under one of the following conditions: 0.3N HCl, 0.01N NaOH, 140°C, or 40°C in water. Automation via autosamplers and system software provides analytical speed and high throughput.

Using this approach, 10 degradants of cefadroxil, an orally effective semisynthetic cephalosporin antibiotic, were elucidated in a 2-day study. The incubation conditions (Table 6.14) are predictive of the conditions expected to occur under drug processing, storage, and physiological conditions throughout drug lifetime. Standard LC/MS methods provide consistency from sample to sample throughout the development process and allow for the construction and use of a structural database for the rapid identification of impurities and degradants during development. The reversed-phase HPLC conditions provide a general measure of the polarity of each compound, useful for interpretation of substructural differences between related compounds. Due to the mass-resolving capability of the mass spectrometer, chromatographic resolution of coeluting or unresolved components is not required. Abundant protonated molecule ions,

TABLE 6.14 Predictive profile conditions used to study cefadroxil and to rapidly produce a structure database

| Condition | Reagent | Reagent Concentration (N) | Time (h) | Temperature (°) |
|-----------------|------------------|---------------------------|----------|-----------------|
| Acid | HCl | 0.3 | 2 | 24 |
| Base | NaOH | 0.01 | 1.5 | Ambient |
| | | 1 | 0.5 | Ambient |
| Heated solid | | | 6 | 140 |
| Heated solution | H ₂ O | | 8 | 40 |

Source: Reprinted with permission from Rourick et al., 1996. Copyright 1996 Elsevier.

$[M+H]^+$, provide reliable molecular weight information, and product ion spectra generate valuable substructure information for each degradant. The product ion spectrum of cefadroxil is used as a template for interpretation because specific product ions and neutral losses are compared to the spectra obtained from the unknown degradants. Product ions common to each spectra provide evidence of substructures unchanged by the degradation conditions and differences are indicative of structural variations. The product ion spectrum of cefadroxil contains an abundant product ion at m/z 208, which is diagnostic of cleavage through the lactam substructure.

The structural data for 18 observed impurities and degradants are shown in Table 6.15. The dimensions of chromatographic behavior and molecular weight are easily referenced within this LC/MS profile. The mass chromatograms (EIC profiles) corresponding to the $[M+H]^+$ ions of selected components are shown in Figure 6.30. This particular representation is useful for distinguishing differences among degradants contained in the base-degraded sample. For

TABLE 6.15 Library of cefadroxil degradants and impurities obtained from predictive profiles obtained by exposing the drug to the various development conditions shown in Table 6.14

| | | | |
|----|------|-----|---|
| 1 | 0.15 | 379 | Cefadroxil + 16Da |
| 2 | 0.20 | 379 | Cefadroxil sulfoxide isomer |
| 3 | 0.26 | 379 | Cefadroxil sulfoxide isomer |
| 4 | 0.32 | | |
| 5 | 0.40 | 317 | |
| 6 | 0.62 | 363 | Cefadroxil isomer |
| 7 | 0.64 | 363 | Δ^2 -Cefadroxil isomer |
| 8 | 0.77 | 233 | |
| 9 | 1.0 | 381 | Cefadroxil with hydrolyzed lactam |
| 10 | 1.0 | 363 | Cefadroxil |
| 11 | 1.98 | 363 | 7-epi-Cefadroxil |
| 12 | 2.12 | | |
| 13 | 2.15 | 363 | Piperazinedione cefadroxil isomer |
| 14 | 2.17 | 377 | Methyl ester of cefadroxil (impurity) |
| 15 | 2.20 | 398 | |
| 16 | 2.25 | 329 | |
| 17 | 2.35 | 512 | Additional side chain (impurity) |
| 18 | 2.38 | 363 | Isomer of piperazine dione of cefadroxil (Δ^2 or 7-epi) |

Source: Reprinted with permission from Rourick et al., 1996. Copyright 1996 Elsevier.

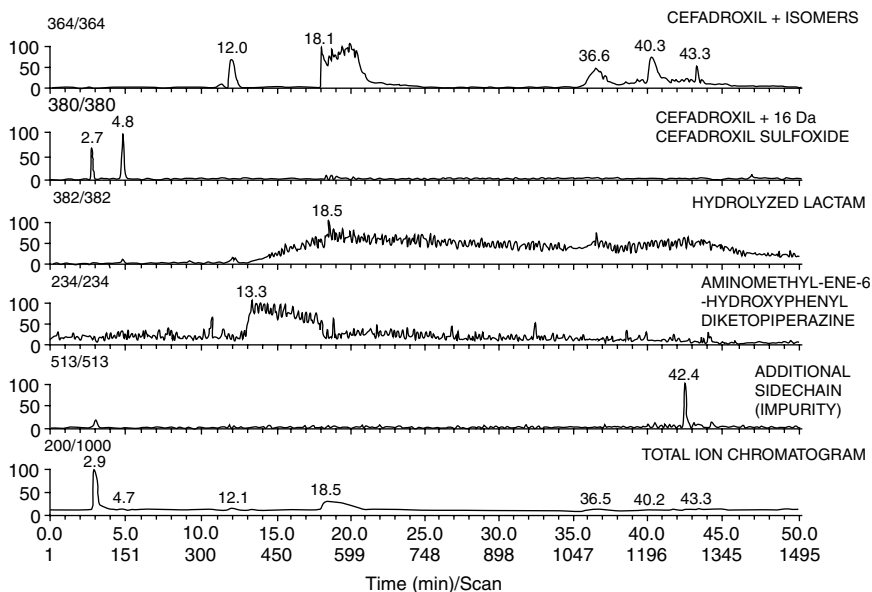

Figure 6.30 The mass chromatograms (EIC profiles) of selected degradants at the m/z values corresponding to their $[M+H]^+$ ions in a base-degraded cefadroxil monohydrate sample. (Reprinted with permission from Rourick et al., 1996. Copyright 1996 Elsevier.)

example, the difference in molecular weight between cefadroxil and a proximate-eluting degradant is 18 Da, which indicates a substructural difference that results from hydrolysis. The product ion spectrum obtained from the degradant does not contain the diagnostic m/z 208 product ion. An abundant product ion at m/z 180 indicates a dihydrothiazine substructure consistent with a hydrolyzed lactam. The hydrolyzed lactam structure is further supported by the presence of a product ion at m/z 141, which results from the neutral loss of NH_3 . The resulting LC/MS structure library provides a predictive foundation for preclinical and clinical development stages that involve drug stability, synthesis, and process monitoring activities. Furthermore, this information aids the development of rugged stability-indicating methods for clinical drug release.

This predictive degradation strategy was demonstrated for biomolecules as a tool to accelerate drug development (Kleintop et al., 1998). Biomolecule samples are exposed to various accelerated stressed environments such as acid, base, heat, high intensity light, and humidity. Molecular weight information obtained from

LC/MS indicated changes in the primary structure. Actual changes in protein sequence are determined with LC/ion trap mass spectrometry (ITMS) methods, and data-dependent MS/MS spectra are generated. The resulting MS/MS spectra are interpreted with the SEQUEST database-searching algorithm. Finally, a rapid LC/MS-based hydrogen/deuterium (H/D) exchange method is used to qualitatively detect changes in the tertiary structure.

Similar to the examples described for small molecules, the resulting biomolecule degradant profile is used to predict potential problems before they appear during preclinical scale-up, formulation, and stability experiments. Furthermore, this information may serve as a diagnostic tool for structure identification during the clinical development and manufacturing stages.

CLINICAL DEVELOPMENT

By the time the drug candidate reaches the clinical development stage, the scale of the chemical process has reached a full production batch size (~kg). The information obtained on impurities and degradants during the preclinical development stage provides a useful historical database. Thus, when significant process changes are made, the impurity profile is reviewed to determine whether the toxicological studies still support development. By far, the most intense use of LC/MS during the clinical development stage involves the quantitative bioanalysis of the drug and drug-related substances in support of pharmacokinetic activities. Sensitive assays are paramount to success, particularly because lead compounds are more potent and require smaller doses than before. The LC/MS-based quantitative bioanalysis assay has emerged as the method of choice due to its high sensitivity and selectivity characteristics. Compatibility with conventional HPLC techniques has streamlined method development and analysis protocols during the transfer from the preclinical stage of development. Other analyses that involve LC/MS support activities deal with alternate dosing formulations (i.e., improved dissolution and long-term stability studies [LTSS]) and drug safety studies (i.e., toxic effects of metabolites, impurities, and degradants). Similar to the drug discovery stage, clinical development proceeds in three phases (I–III), where increasing levels of information are collected and increasing levels of criteria are required to proceed to the next phase.

Analysis Requirements. During the clinical development stage, the scale of process and sample volume is significantly increased, with an intense focus on only a few drug candidates. For example, a multi-subject pharmacokinetics study can generate well over 1000 samples in varying matrices such as plasma and urine. Also, attention shifts to the assurance of quality drug product for human use and the accumulation of information for new drug application/marketing authorization application (NDA/MAA) approval. Furthermore, clinical development studies often result in new impurity and degradant profiles as the chemical scale-up process and formulation are improved. New degradants are generated from LTSS and require structure identification. Also, human studies produce a new metabolite profile compared to those observed in animal models. In many ways, the analysis requirements for clinical development are similar to those required for drug discovery. Large numbers of samples must be analyzed, typically for a single analyte (e.g., pharmacokinetic studies), from clinical trials that involve 10,000 to 12,000 patients (Thompson, 1995) and a premium is placed on sensitivity (low ng/mL) and speed of analysis (<5 min).

Analysis Perspectives. A central issue of this phase is the completion of analyses under strict good laboratory practice (GLP) and good manufacturing practice (GMP) guidelines. This requirement adds cost, but it ensures reproducible results. Despite the diversity of sample matrices produced during clinical development, a large number of samples can be analyzed with the same method. This standard approach produces greater efficiencies by providing: (1) reduced method development, (2) a reference database for a drug candidate, and (3) reduced repetitive analyses. Frequently, a compound initially identified as a metabolite may also be observed as a degradant or impurity in pharmaceuticals or process research samples. The early lock-in of methods leads to the efficient analysis of samples throughout the lifetime of the project. In major studies, like pharmacokinetic or stability studies, large numbers of samples are produced; however, these studies typically feature a targeted analysis, where known compounds such as the parent drug or a specific metabolite are quantitatively measured. Furthermore, the samples are usually presented within a consistent matrix (i.e., plasma, urine) that allows for efficient batch processing. The issues related to sample preparation (Henion et al., 1998) and ionization suppression (Buhrman et al., 1996; Matuszewski et al., 1998; King et al., 2000) are

distinctly unique, and over the years, provide many important lessons to consider for successful pharmaceutical analysis.

LC/MS Contributions. LC/MS analysis plays a major role in the success, efficiency, and timeliness of clinical development. The widespread acceptance of LC/MS in the area of pharmacokinetics has led to major investments within pharmaceutical companies and contract analytical laboratories. LC/MS has demonstrated a clear advantage to HPLC for quantitative pharmacokinetic studies, in terms of method development time, cost, sample throughput, and turnaround. A review describes the powerful capabilities of LC/MS/MS approaches for quantitative bioanalysis studies (Brewer and Henion, 1998). Two LC/MS-based methods, selected ion monitoring (SIM) and selected reaction, monitoring (SRM), are invaluable tools for quantitative analysis in clinical development and are featured in this section. The emphasis on highly automated chromatography-based sample preparations is highlighted with examples that involve off-line SPE and on-line extraction techniques. Structure identification has also played a major role in accelerating clinical development. The rapid availability of structural information provides an improved understanding, in real-time, as processes and formulations are developed and metabolism is investigated. This information contributes to highly efficient clinical development activities that lead to successful NDA/MAA filings. LC/MS structural information is also used extensively as part of a multidisciplinary structure elucidation strategy for impurities, degradants, and metabolites; that information is also required for the NDA/MAA.

Overview. This section about clinical development illustrates the application of LC/MS and LC/MS/MS for quantitative bioanalysis during this stage. Examples that feature SIM (Fouda et al., 1991), SRM (Dear et al., 1998), automated off-line SPE extraction methods (Allanson et al., 1996; Simpson et al., 1998), and on-line extraction LC/MS methods (Needham et al., 1998) are described. The SIM and SRM examples emphasize mass spectrometry-based analysis strategies, whereas extraction approaches emphasize the critical role of chromatographic separations, and to some extent, sample preparation. Also described are applications that deal with the identification of metabolites during clinical studies (Lokiec et al., 1996) and degradants during LTSS (Volk et al., 1996). Table 6.16 provides a summary of the LC/MS-based applications featured in this section.

TABLE 6.16 Representative applications of LC/MS in clinical development

| Clinical Development Activity | Analysis | LC/MS Application | Selected References |
|-------------------------------|---------------------------|---|---|
| Pharmacokinetics | Quantitative bioanalysis | Selected ion monitoring | Fouda et al., 1991 Wang-Iverson et al., 1992 |
| | | Selected reaction monitoring | Covey et al., 1986 Kaye et al., 1992 |
| | | Automated off-line solid-phase extraction | Allanson et al., 1996 Simpson et al., 1998 |
| | | Automated on-line extraction | Needham et al., 1998 |
| Metabolism | Metabolite identification | | Lokiec et al., 1996 |
| Long-term stability | Degradant identification | Standard method LC/MS protocol | Volk et al., 1996 |

The selection of a particular approach is discussed, with an emphasis on multiple stages of separation, chromatographic and mass, for providing unique capabilities and features for analysis. The applicability of these approaches to a wide variety of compounds of pharmaceutical interest is highlighted and compared to traditional quantitative analysis methods that use HPLC and GC/MS.

Quantitative Bioanalysis—Selected Ion Monitoring

The quantitative analysis of targeted components in physiological fluids is a major requirement in the clinical development stage. In 1991, Fouda demonstrated the use of APCI-LC/MS for the quantitative determination of the renin inhibitor, CP-80,794, in human serum. Because the pharmacological action is below 200 pg/mL, a quantitative assay in the low pg/mL range is required to monitor the drug's pharmacokinetic and pharmacodynamic properties. The structure of CP-80,794 (Figure 6.31) corresponds to a modified peptide of molecular weight 620. The molecule lacks a significant chromophore for UV detection with conventional HPLC methods. Also, the low volatility and thermal instability precluded analyses with GC/MS methods.

Quantitative LC/MS assays generally involve four steps: (1) sample preparation, (2) assay calibration, (3) sample analysis, and (4) data management. In this method, the human serum samples are prepared with a liquid-liquid extraction procedure. The internal

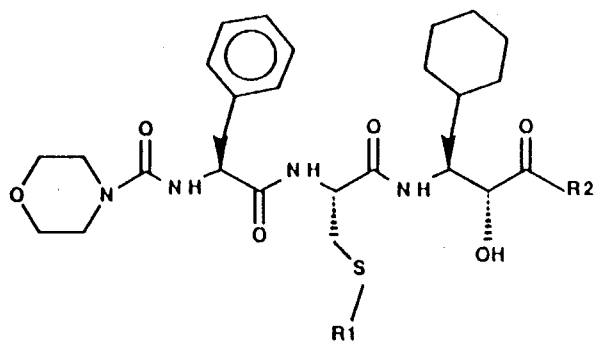

| | <u>R₁</u> | <u>R₂</u> | <u>Molecular Wt.</u> |
|-----------------------------|-------------------------------|----------------------|----------------------|
| I. Analyte: CP-80,794 | CH ₃ | | 620 |
| II. Internal Std: CP-88,587 | C ₂ H ₅ | | 634 |
| III. Carrier: CP-81,489 | CH ₃ | NH — CH ₃ | 591 |

Figure 6.31 The structure of CP-80,794 and analogues used in the SIM LC/MS quantitative assay of CP-80,794 in plasma. (Reprinted with permission from Fouda et al., 1991. Copyright 1991 Elsevier.)

standard (1 ng) and carrier compound (50 ng), which is a structural analog of CP-80,794 (Figure 6.31), are added to samples of human serum (1 mL aliquot). The addition of the carrier compound is responsible for reducing any adsorption losses during sample preparation and LC/MS analysis (Self, 1979), and for enhancing the extraction efficiency and precision of the assay (Lee and Millard, 1975).

Assay calibration involves the use of human serum samples fortified with CP-80,794 at 11 concentrations (six replicates per concentration) ranging from 0.05 to 10 ng/mL. In this particular case, due to a narrow linear dynamic range, two standard curves, ranging from 0.05 to 10 ng/mL, are constructed to provide the best accuracy. Serum blanks and an 11-point standard curve (two samples per concentration) are analyzed with each set of unknown samples.

The LC/MS analysis involves the use of SIM to monitor the molecular ions $[M-H]^-$ that correspond to the drug (m/z 619) and internal standard (m/z 633). In this LC/MS application, the negative ion mode is highly sensitive for this class of compound. Samples are loaded onto an HPLC autosampler and 80 μ L aliquots are injected onto the column at 4 min intervals. The solvent front is observed at 1.0 min and the elution times of the drug and internal standard are 3.1, and 3.4 min, respectively.

The standard curves obtained from the CP-80,794 assay are shown in Figure 6.32. Background subtraction routines are applied to obtain the best linear regression analyses and smallest y-intercept. The accuracy and precision of this assay are highlighted in Table 6.17, and representative HPLC chromatograms are shown in Figure 6.33.

At the time, this application provided a powerful benchmark for the use of LC/MS-based methods in the pharmaceutical industry. This particular assay successfully supported several clinical studies with sensitive and reliable results. This performance was benchmarked on more than 4000 clinical samples and led to a wider scope of application and the development of routine, standard methods for quantitative bioanalysis.

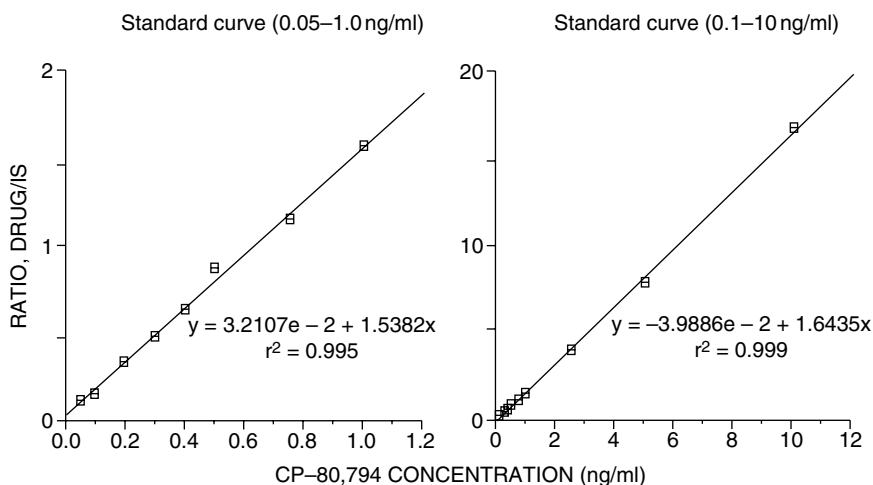

Figure 6.32 Standard curves of the CP-80,794 SIM LC/MS assay for concentrations ranging from 0.05 to 10 ng/mL. (Reprinted with permission from Fouada et al., 1991. Copyright 1991 Elsevier.)

TABLE 6.17 Analysis of serum samples that contain known amounts of CP-80,794^a

| Fort. conc. ^b (ng/mL) | Conc. Found (ng/mL) | C.V. ^c | % Accuracy |
|-------------------------------------|------------------------|-------------------|------------|
| 0.05 | 0.052 | 7.7 | 104 |
| 0.10 | 0.119 | 10.1 | 119 |
| 0.20 | 0.227 | 9.7 | 113 |
| 0.30 | 0.313 | 6.4 | 104 |
| 0.40 | 0.407 | 5.4 | 102 |
| 0.50 | 0.556 | 7.7 | 111 |
| 0.75 | 0.717 | 5.0 | 96 |
| 1.00 | 1.034 | 5.8 | 103 |
| 2.50 | 2.488 | 12.5 | 100 |
| 5.00 | 4.820 | 6.7 | 96 |
| 10.00 | 10.094 | 9.9 | 101 |

Source: Reprinted with permission from Fouda et al., 1991. Copyright 1991 Elsevier.

^a Intraassay parameters [$n = 6$].

^b Fortified concentration.

^c Coefficient of variation.

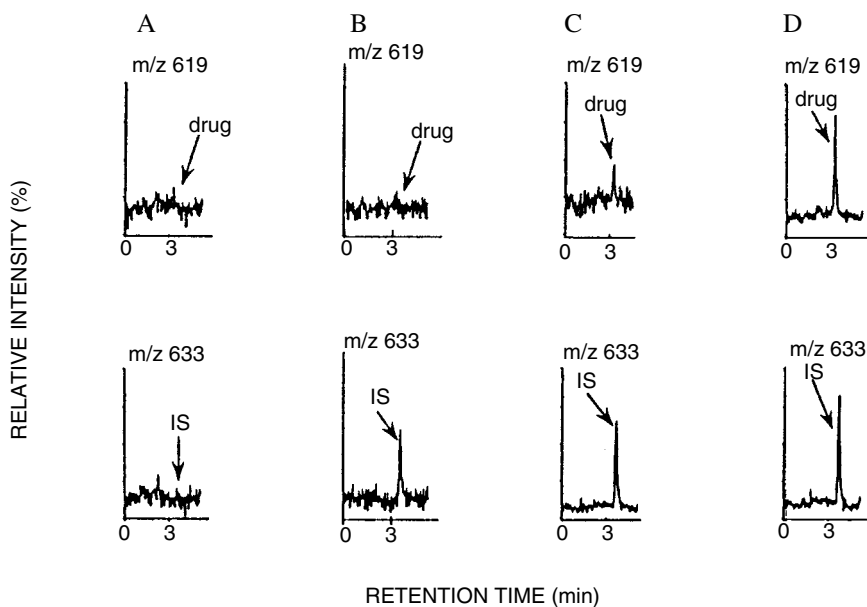

Figure 6.33 Representative HPLC chromatograms of human serum samples for the CP-80794 SIM LC/MS assay. Extracted ion current profiles for: (A) Blank; (B) Blank plus internal standard; (C) 0.1 ng/mL CP-80,794; (D) 0.5 ng/mL CP-80,794. (Reprinted with permission from Fouda et al., 1991. Copyright 1991 Elsevier.)

Quantitative Bioanalysis—Selected Reaction Monitoring

After the work of Fouda and colleagues, a tremendous growth in the LC/MS application for quantitative bioanalysis ensued in the clinical development stage of drug development. Similar LC/MS-based approaches that used SIM methods for quantitation (Wang-Iverson et al., 1992) to the highly selective SRM methods (Kaye et al., 1992) became popular. The strategic emphasis was on increased dimensions of analysis (chromatography and mass separations) to provide a higher selectivity and rapid cycle times.

The use of SRM methods for quantitative bioanalysis represents increased dimensions of mass spectrometry analysis. SRM methods that use APCI-LC/MS/MS for the quantitative analysis of an antipsychotic agent, clozapine, in human plasma were described by Dear and co-workers (Dear et al., 1998). Preclinical development studies of clozapine in rats and dogs used HPLC with fluorescence detection (FLD). With this method, a better limit of quantitation (LOQ) of 1 ng/mL was obtained. As the compound moved into the clinical stages of development, a more sensitive method of analysis was required to obtain rapid metabolic information in support of drug safety evaluation studies. A standard LC/MS/MS method is used for the quantitative analysis of clozapine (I) and four metabolites (II–V) in human plasma (Figure 6.34).

The LC/MS/MS strategy is similar to previously described approaches for protein, natural products, metabolite, and impurity identification. An ionization technique that generates abundant molecular ion species with very little fragmentation is desirable. The product ion spectrum is obtained to generate the substructural template of the molecule. Abundant and structurally unique transitions (molecular ion → product ion) are identified from the spectrum and are used in the corresponding SRM experiment for quantitation. The SRM experiment provides a high degree of selectivity and better LOD than full-scan or SIM experiments for the analysis of complex mixtures (Johnson and Yost, 1985; Kusmierz et al., 1990). As highlighted in the previously described LC/MS/MS applications, the selectivity of MS/MS reduces the requirements for complete chromatographic resolution of each component. Therefore, LC/MS/MS experiments for quantitation typically emphasize short analytical run times to provide high sample throughput.

The full-scan mass spectrum of clozapine contains an abundant $[M+H]^+$ ion at m/z 410 with little fragmentation (Figure 6.35). The

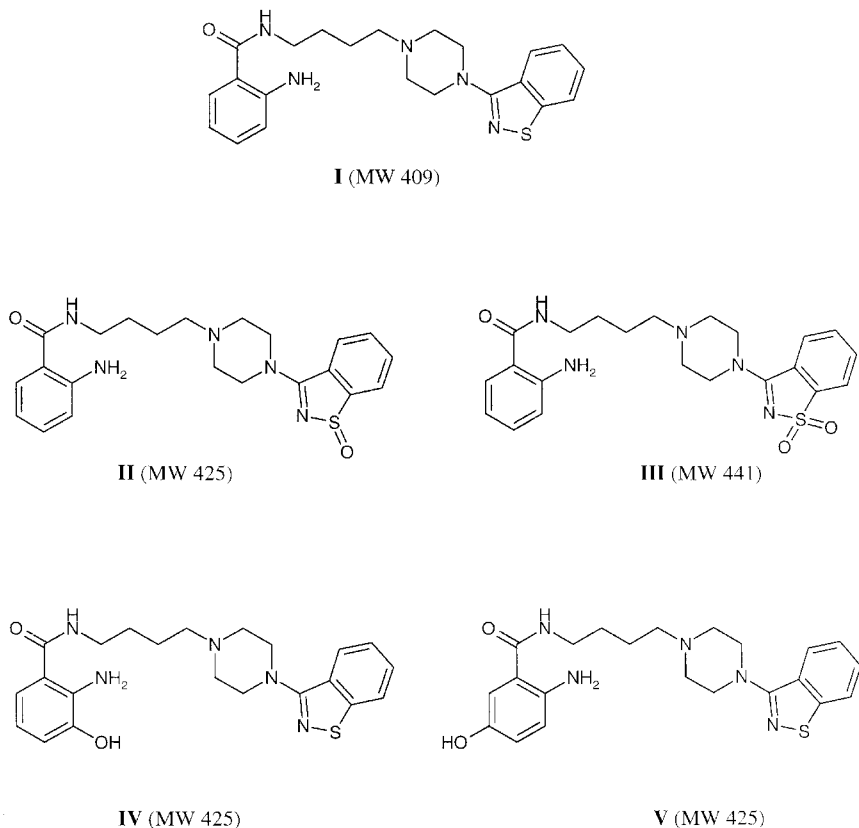

Figure 6.34 Structures of clozapine (I) and four metabolites (II–V) assayed in human plasma with SRM LC/MS/MS. (Reprinted with permission from Dear et al., 1998. Copyright 1998 Elsevier.)

$^{13}\text{C}_6$ -labeled clozapine internal standard exhibited similar performance in the full-scan mass spectrum; an abundant $[\text{M}+\text{H}]^+$ ion at m/z 416 is produced. Figure 6.35 also shows the product-ion spectra of the $[\text{M}+\text{H}]^+$ ion of clozapine and of the $^{13}\text{C}_6$ -labeled internal standard. This spectrum provides the structural template for identification and contains the abundant fragment at m/z 120 and 126, respectively, which corresponds to the benzamide substructure. Thus, the structurally unique transition of clozapine ($410^+ \rightarrow 120^+$) and the $^{13}\text{C}_6$ -labeled internal standard ($416^+ \rightarrow 126^+$) are selected for SRM quantitation experiments. Using this approach, the structurally unique transitions for the metabolites (II–V) are obtained. Figure 6.36 shows representative LC/MS/MS SRM chromatograms

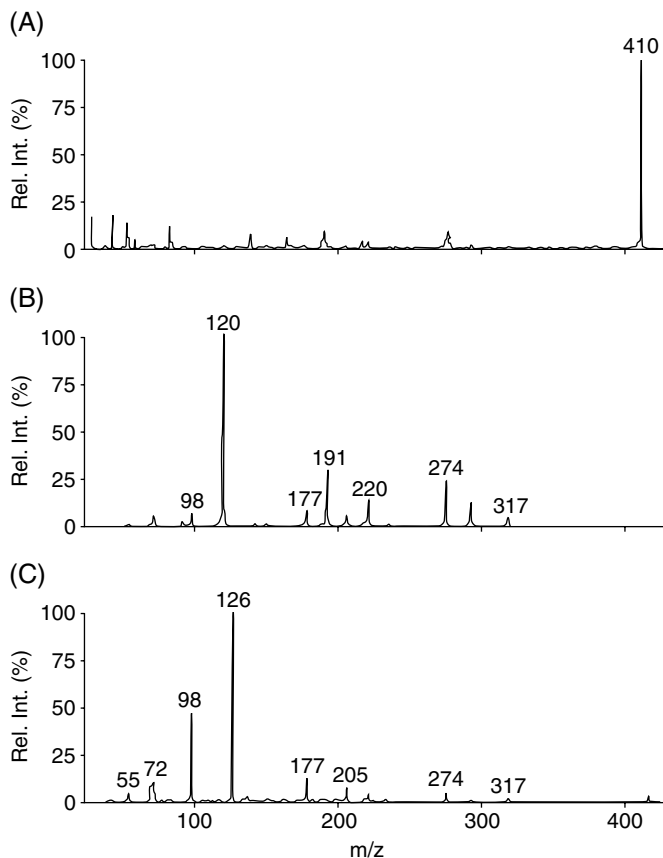

Figure 6.35 Positive APCI mass spectra: (A) Full-scan mass spectrum of clozapine; (B) product ion spectrum of clozapine; (C) product ion spectrum of $^{13}\text{C}_6$ -clozapine internal standard. (Reprinted with permission from Dear et al., 1998. Copyright 1998 Elsevier.)

obtained from the analysis of an extract of a 50 pg/mL calibration standard. A mobile phase of 75% (v/v) acetonitrile in 20 nM ammonium formate at pH 4.0 provides good chromatographic peak shape, and the drug and internal standard elute <2 min.

The inter- and intraassay precisions of this method are less than 8% of the coefficient of variation (CV) across the range of the limits of quantification (0.05–10 ng/mL). The accuracy (percentage bias) for all spiked control concentrations does not exceed $\pm 4\%$. Same-day turnaround of results for more than 100 samples is possible with this LC/MS/MS method. This method was used to support an acute

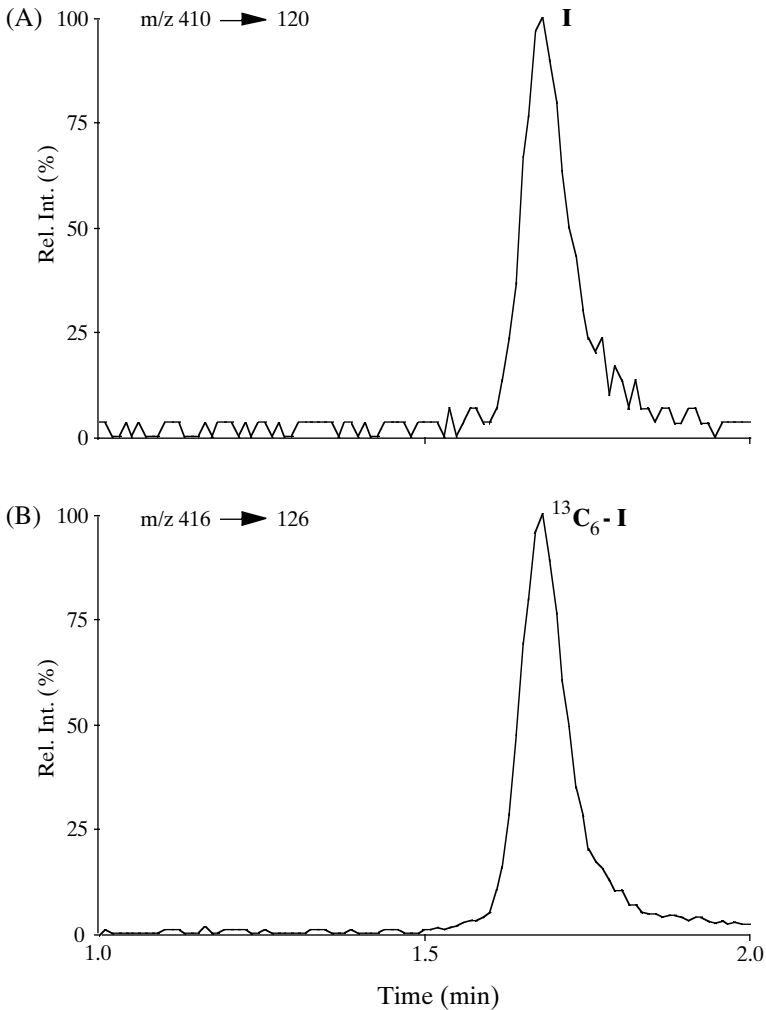

Figure 6.36 Representative LC/MS/MS SRM chromatograms obtained from the analysis of an extract of a 50 pg/mL calibration standard. (A) Chromatogram for the m/z 410 precursor to m/z 120 product ion of clozapine. (B) Chromatogram of the m/z 416 precursor to m/z 126 product ion of $^{13}\text{C}_6$ -clozapine [internal standard]. (Reprinted with permission from Dear et al., 1998. Copyright 1998 Elsevier.)

dose tolerance and pharmacokinetic study that involved the analysis of 1600 samples.

Quantitative Bioanalysis—Automated Solid-Phase Extraction

As the trend toward obtaining more information earlier in the drug development cycle expanded, methodologies that involve sample preparation were exposed as the rate-limiting steps in workflow during quantitative bioanalysis activities. The LC/MS analysis was, indeed, the most efficient part of the overall process. Activities involved with sample tracking, sample preparation, data processing, and archiving presented the greatest challenge in a high-throughput environment. Opportunities with automated sample preparation using SPE in conjunction with LC/MS approaches attracted much attention due to compatibility with robots and batch-mode processing (Kaye et al., 1996). The analysis emphasis focused on the increased dimensions of chromatographic separation.

The work performed by Pleasance and co-workers highlighted the novel use of automated SPE in a 96-well format for high-throughput bioanalysis in support of the migraine drug candidate 311C90 (Allanson et al., 1996). Initially, the clinical development of this drug candidate was supported with a 25 min HPLC analysis with fluorescence detection. Traditional packed-cartridge SPE was used for the extraction of human plasma in a sequential on-line mode (8 min extraction time). This method provides an LOQ of 2 ng/mL. However, as the clinical development of 311C90 progressed, the dose was decreased; thus, a more sensitive method was needed. Also, cycle times of the automated on-line sample preparation and analysis were too slow for the LC/MS/MS time scale and the large number of samples from clinical studies. This situation required a method with increased sensitivity, shorter analysis time, and faster extraction cycle time.

The analysis strategy uses LC/MS/MS in combination with a 96-well disk plate SPE. The activities associated with sample preparation and analysis are decoupled to simplify troubleshooting and to allow for greater flexibility. The benefit of this off-line approach is the ability to simultaneously prepare 96 samples with SPE in 1 h, followed by the LC/MS/MS analysis on each sample. Previous approaches with individual SPE cartridges required 2–3 h.

Sample preparation is automated for high-throughput batch processing with SPE, which is better suited for automation than other

sample preparation methods (e.g., liquid–liquid extraction). The SPE cartridges are bundled together in a block with the same dimensions as a 96-well plate (Kaye et al., 1996) to achieve increased throughput and to use with standardized robotics formats. Samples are collected into a deep well (1 mL) collection plate with a 300 μ L elution volume.

In this study, the LC/MS/MS analysis is <3 min, with injections occurring every 3.5 min. The previous HPLC method with fluorescence detection had a cycle time of 25 min. Thus, many opportunities exist with LC/MS/MS quantitative analyses to optimize chromatographic separations for speed. Similar to standard approaches described for open-access or metabolite identification, standard or generic methods may be usable with this application (Dear et al., 1998).

The mass spectrometry performance of 311C90 and related compounds is illustrated in Figure 6.37. The full-scan mass spectrum features an abundant $[M+H]^+$ ion at m/z 288, and essentially no fragmentation (Figure 6.37A). The corresponding product ion spectrum of the $[M+H]^+$ ion of 311C90 indicates several useful product ions that correspond to unique substructures (Figure 6.37B). In this case, the product ion at m/z 58, corresponding to $[(CH_3)_2N=CH_2]^+$, is selected with $[M+H]^+$ ion for the SRM experiment. For the desmethyl metabolite (183C91) and the deuterated internal standard (2H_6 -311C91), the m/z 182 and 64 product ions, respectively, are selected with their corresponding $[M+H]^+$ ion for SRM. The LC/MS/MS SRM chromatograms obtained from the analysis of an extract of a 100 pg/mL calibration standard are shown in Figure 6.38. Each analyte and internal standard elutes in less than 4 min.

This strategy provides a 10-fold increase in sensitivity, which results in an LOQ of 0.1 ng/mL. All liquid handling (i.e., dilution, sample, internal standard addition) is automated, and 96 samples are prepared in 1 h. This rate compares to 3 h via manual means or 5 h with a traditional on-line system approach. During the daytime, 2–3 blocks are extracted and analyzed by LC/MS/MS during the evening. Chromatographic resolution of the drug, the metabolite, and the standard is not required, due to the structure-resolving capability of MS/MS. The instrument cycle time is reduced to 3.5 min from the former 25 min.

In a period of 6 h, 96 samples plus standards and quality control (QC) samples are analyzed with this method. Other assays have been performed with 2 min cycle times. Unattended analysis of six

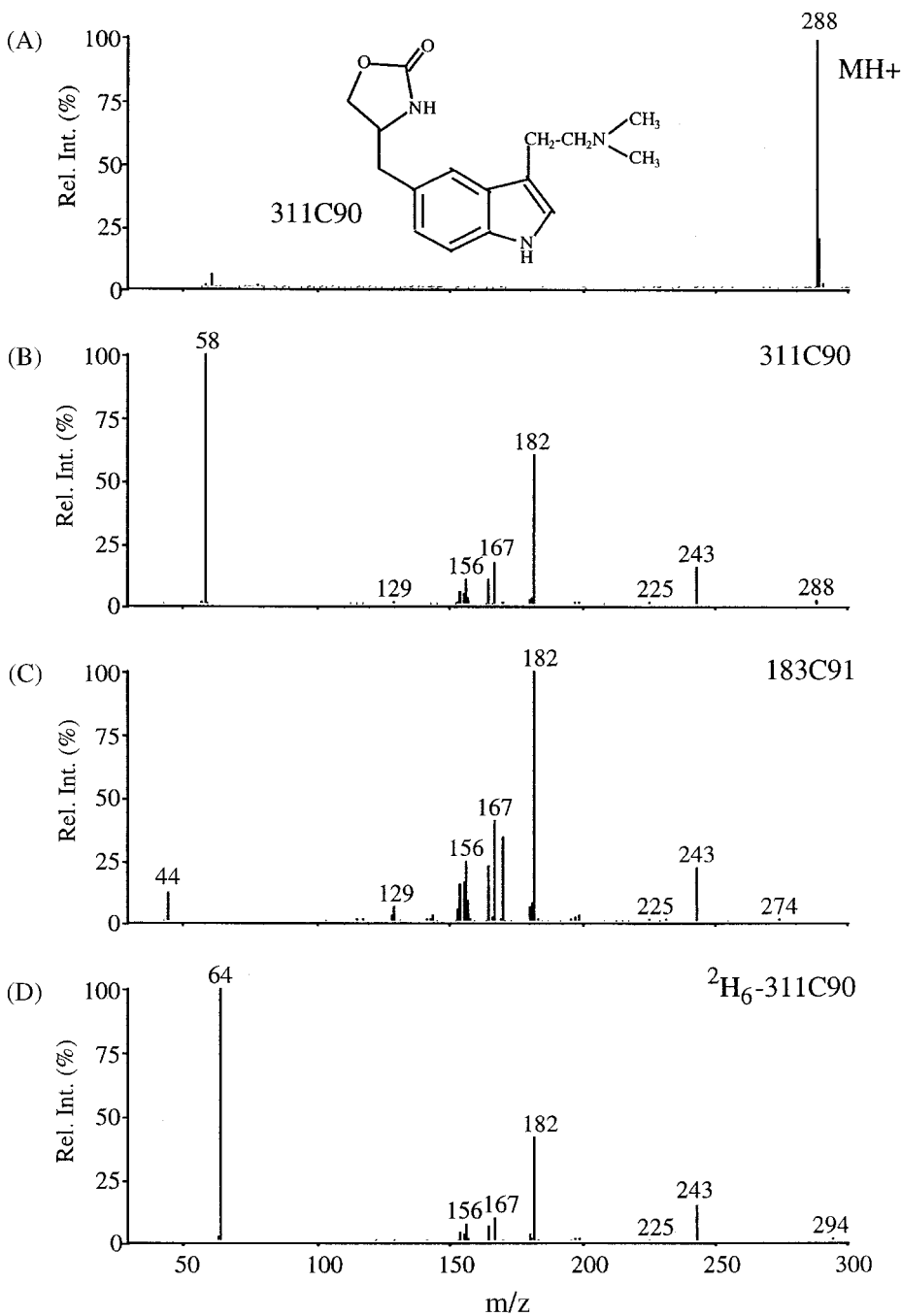

Figure 6.37 Mass spectrometry of 311C90 and related compounds. (A) Full-scan positive ion electrospray spectrum of 311C90. Product ion spectra of the: (B) [M+H]⁺ ion of 311C90, (C) [M+H]⁺ ion of 183C91 (desmethyl metabolite), and (D) [M+H]⁺ ion of ²H₆-311C90 (internal standard). (Reprinted with permission from Allanson et al., 1996. Copyright 1996 John Wiley & Sons.)

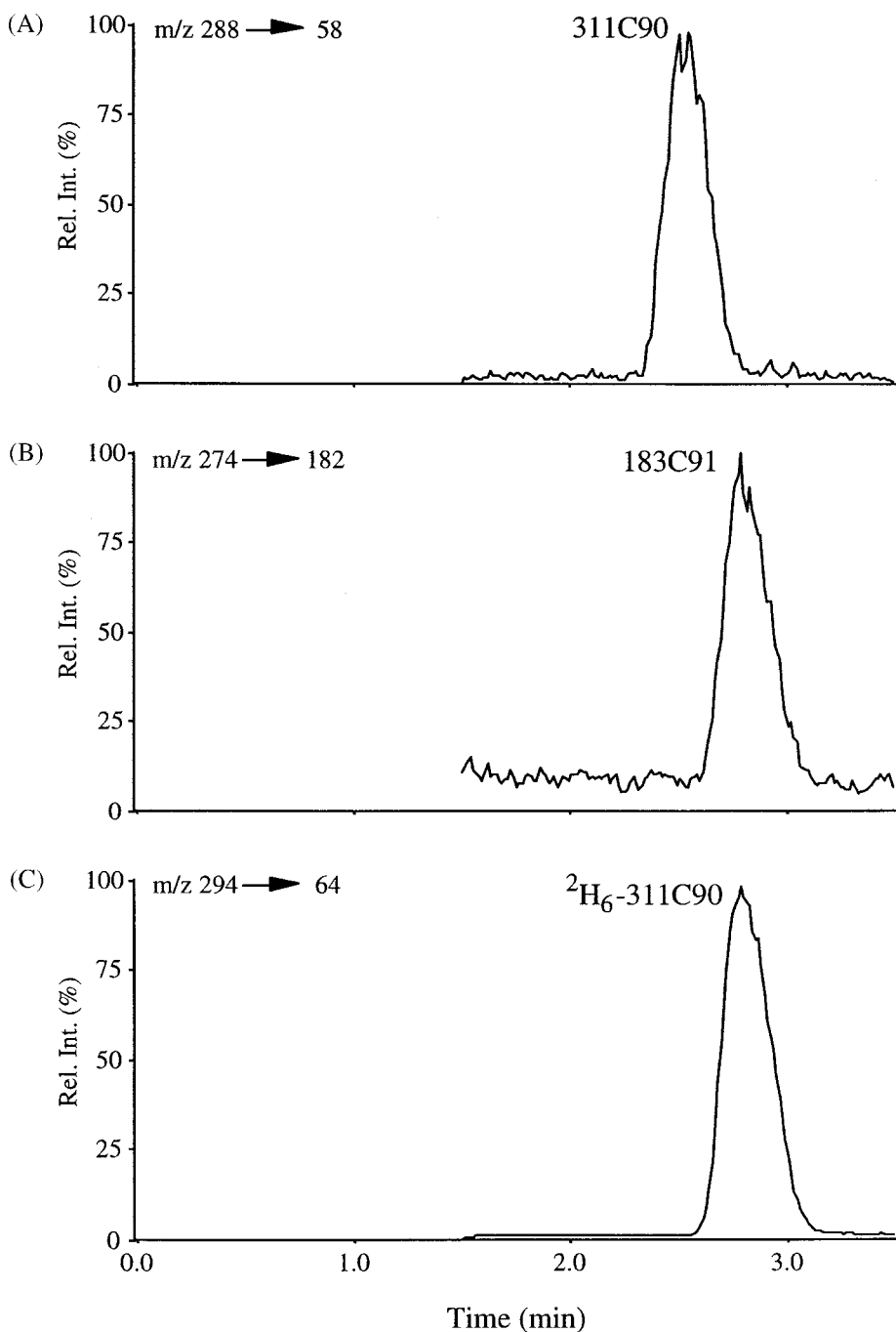

Figure 6.38 LC/MS/MS SRM chromatograms from the analysis of an extract of a 100 pg/mL calibration standard. (A) Chromatogram for the $[\text{M}+\text{H}]^+$ precursor ion to m/z 58 product ion of 311C90. (B) Chromatogram for the $[\text{M}+\text{H}]^+$ precursor ion to m/z 182 product ion of 183C91 (demethyl metabolite). (C) Chromatogram of the $[\text{M}+\text{H}]^+$ precursor ion to m/z 64 product ion of $^2\text{H}_6$ -311C90 [internal standard]. (Reprinted with permission from Allanson et al., 1996. Copyright 1996 John Wiley & Sons.)

plates (576 injections) is common. Approximately 800 clinical samples have been analyzed with this method during 48 h of continuous operation.

The work of Kaye and colleagues and Pleasance and co-workers provided the interest and motivation to extend sample preparation capabilities into an off-line batch mode process. This motivation was also stimulated by sample preparation bottlenecks, which typically occurred during on-line bioanalysis, where the limiting factor was associated with extraction and cleanup procedures. The rationale was to perform sample preparation tasks with an automated procedure followed by the transfer.

A 96-well SPE system for the simultaneous extraction of drugs and metabolites in biological matrices developed by Wu and co-workers (Simpson et al., 1998) is shown in Figure 6.39. In this approach, smaller elution volumes (75–200 μL) are used to improve SPE performance. This volume reduction allowed for the direct injection of samples without any evaporation and reconstitution. The collection plate that contains the elution fraction is loaded to an autosampler that is compatible with 96-well plates, thereby, eliminating the transfer to injection vials. This quantitative process improvement led to an improved analytical performance, considerable savings in time, and reduced cost.

The performance of this LC/MS/MS quantitative analysis was demonstrated on a selective muscarinic M1 receptor partial agonist, SR 46559, which was under clinical development for the potential symptomatic treatment of the cognitive disorders associated with Alzheimer's disease. The full-scan mass spectrum and the corresponding product ion spectrum are shown in Figure 6.40. The m/z 268 product ion is identified along with the $[\text{M}+\text{H}]^+$ ion at m/z 341 for the SRM experiment. Also, the m/z 273 product ion and m/z 346 $[\text{M}+\text{H}]^+$ ion from the corresponding internal standard, $^2\text{H}_5$ -SR 46559, are identified for SRM.

Table 6.18 illustrates the cost analysis of a traditional disk cartridge SPE and the 96-well SPE system. Savings of \$52 per 100 processed samples were calculated, which does not include the savings obtained from reduced solvent consumption and waste disposal. When combined with the fact that this system requires minimal user intervention (adding the collection plate) and is significantly faster than traditional extraction procedures (1 h per 96 samples versus 4–5 h), the 96-well SPE format offers powerful

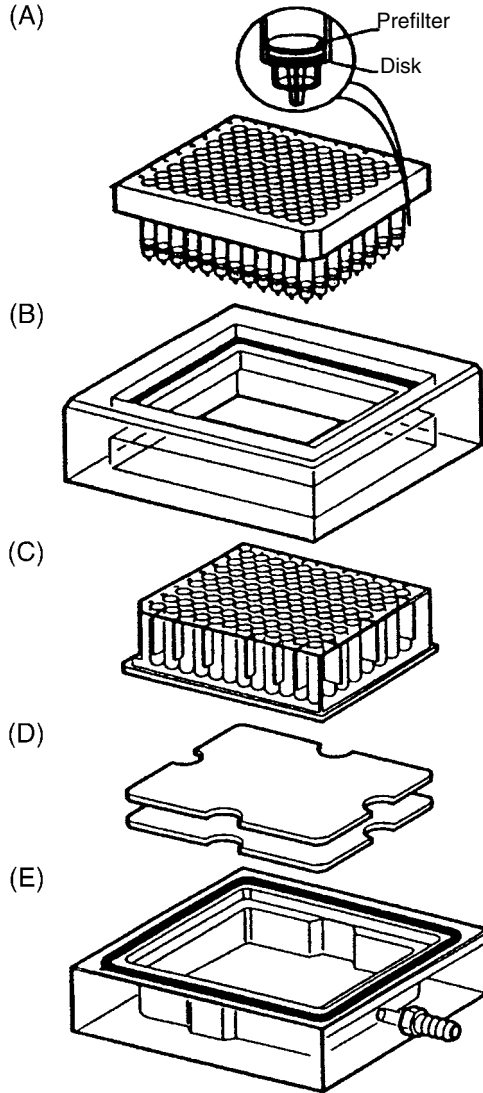

Figure 6.39 Parallel extraction of 96 samples with an Empore 96 individual disk SPE plate (A) and vacuum manifold system, including an acrylic vacuum manifold top (B), a polypropylene deep-well collection plate (C), two shims (D) for height adjustment of the collection plate, and a Delrin vacuum manifold (E) bottom. (Reprinted with permission from Simpson et al., 1998. Copyright 1998 John Wiley & Sons.)

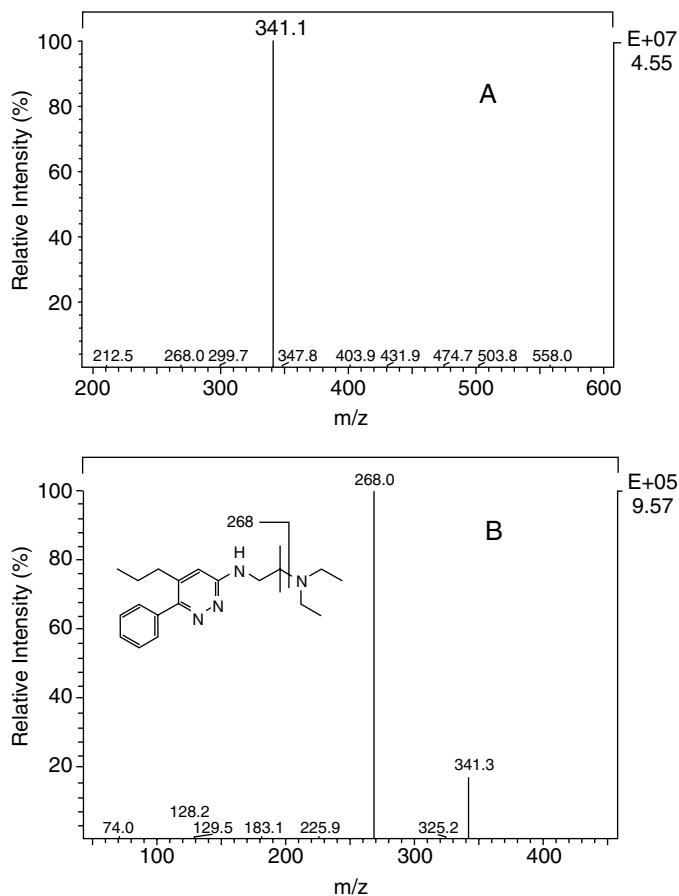

Figure 6.40 Positive electrospray mass spectra of SR 46559. (A) Full-scan mass spectrum, (B) Product ion spectrum of the $[M+H]^+$ ion at m/z 341. (Reprinted with permission from Simpson et al., 1998. Copyright 1998 John Wiley & Sons.)

advantages for high-throughput bioanalysis in combination with LC/MS/MS techniques.

Quantitative Bioanalysis—Automated On-Line Extraction

In response to off-line SPE assays in the 96-well plate format, LC/MS analyses that feature the direct injection of plasma with on-line extraction have been reported (Ayrton et al., 1997; Needham et al., 1998). This quantitative process approach eliminates the time-

TABLE 6.18 Comparison in consumable costs between disk cartridge and 96-well plate for every 100 samples^a

| Disk Cartridge | \$ | 96-Well Plate | \$ |
|-----------------|-----|-----------------|-----|
| Cartridge | 154 | Plate | 208 |
| Receiving tube | 41 | Receiving plate | 4.7 |
| Injection vials | 60 | | |
| Pipette tips | 10 | | |
| Total | 265 | Total | 213 |

Source: Reprinted with permission from Simpson et al., 1998. Copyright 1998 John Wiley & Sons.

^a Based on invoices incurred from January to August 1997.

consuming sample extraction step and provides an opportunity to perform an integrated on-line automated method for extraction and analysis. The use of turbulent flow chromatography, which features high linear velocities and large particle size stationary phases, is described by Ayrton and colleagues. The use of restricted access media (RAM) HPLC column, specifically designed to accommodate the direct injection of plasma and other biological fluids, is highlighted in the approach described by Needham and co-workers.

The utility of the RAM approach was demonstrated on a drug that was undergoing clinical evaluation as an anxiolytic agent, CP-93 393. The LC/MS analysis configuration is shown in Figure 6.41. This dual plasma extraction column setup allows the extraction on one column to proceed while the other column is equilibrating and rinsing from the previous injection. The analysis procedure involves 2.5 min of extraction on column (2 mL/min), followed by backflushing with the analytical mobile phase to elute the analytes onto an analytical column (0.5 mL/min).

With this on-line automated method, more than 250 samples have been analyzed unattended in a 24 h period. Good results are obtained over a 10–1000 ng/mL range. The LOQ and LOD are 190 pg and 58 pg, respectively. Accuracy and precision values are 9.0% or better over the entire range of the assay.

Sample preparation issues inherent with on-line extraction techniques that deal with the addition of triethylamine to the mobile phase and the calculation of extraction recovery are likely to be addressed for future applications; however, this method appears to

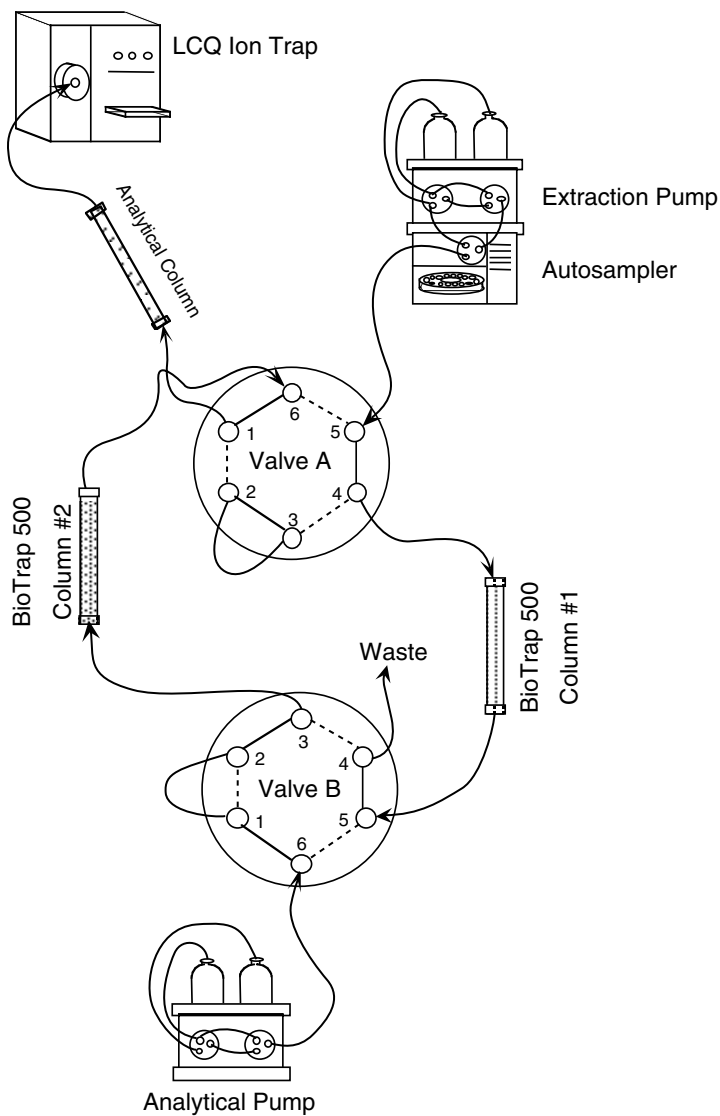

Figure 6.41 Diagram of the instrument configuration for integrated dual BioTrap column plasma extraction and LC/MS analysis. Extraction proceeds on one column while the other column is equilibrating and rinsing. (Reprinted with permission from Needham et al., 1998. Copyright 1998 Elsevier.)

be widely applicable throughout drug development. Previous examples for the quantitative bioanalysis highlighted in this book feature single- and triple-quadrupole instruments. This example features the use of an ion trap mass spectrometer. The performance capabilities and potential implications of this mass spectrometer for quantitative bioanalysis have been described (Tiller et al., 1997b; Wieboldt et al., 1998).

Metabolite Identification

During the course of clinical development, it is often important to identify the structures of metabolites. This information provides an opportunity to better understand interpatient variability in pharmacokinetics and toxicity. Clinical studies performed by Lokiec and co-workers, 1996 on a semisynthetic derivative of 20(S)-camptothecin, CPT-11, demonstrate the use of LC/MS to investigate the *in vivo* metabolic pathways. CPT-11 is a potent inhibitor of topoisomerase II, which is an enzyme involved in DNA duplication, and exhibits significant activity against various types of tumors in clinical studies. The understanding and control of the main biotransformation pathways are particularly important for anticancer drugs because therapeutic doses are often close to the maximum tolerated dose.

In the clinical studies involving CPT-11, bile and urine collected over a 48 h period were prepared with SPE procedures. The resulting extracts were profiled with LC/MS and LC/MS/MS. The analysis involves the use of the product ion spectrum of CPT-11 (Figure 6.42) as the structural template for the identification of metabolite structures. The spectrum contains many diagnostic fragment ions that correspond to unique substructures of the molecule. Fragment ions at m/z 167 and 195 correspond to the piperidine and piperidine-carboxyl substructures, respectively. Abundant ions at m/z 375 and 331 correspond to the 7-ethyl-camptothecin core structure, and the ion at m/z 502 corresponds to the 7-ethyl-camptothecin core structure plus the proximal piperidine. As described in the previous sections that highlighted the MS/MS template approach for structure identification, these ions serve as diagnostic markers for structural modification. Thus, any shift observed in the product ion spectra of CPT-11 metabolites indicates a modified CPT-11 substructure. The qualitative structural information derived using this strategy is summarized in Table 6.19.

Analysis of bile and urine extracts indicate that oxidation of the

TABLE 6.19 Identification of CPT-11 metabolites in bile and urine

| Compound | Molecular Mass | MH ⁺ Daughter Spectrum | Comments | Peak Intensity | |
|----------|----------------|--|---|----------------|-------|
| | | | | Bile | Urine |
| 1 | 586 | <i>m/z</i> 543 (−CO ₂) <i>m/z</i> 502 (−85 amu) <i>m/z</i> 84, 167, 195 | CPT-11 | High | High |
| 2 | 392 | — | SN-38 | High | High |
| 3 | 602 | <i>m/z</i> 559 (−CO ₂) <i>m/z</i> 502 [−(85 + 16) amu] <i>m/z</i> 183 (167 + 16 amu) | Oxidation of terminal piperidine | High | Low |
| 4 | 574 | <i>m/z</i> 557 (−18 amu) <i>m/z</i> 474 [−(85 + 16) amu] <i>m/z</i> 183 (167 + 16 amu) | Oxidation of terminal piperidine of metabolite 5 | Low | nd |
| 5 | 558 | <i>m/z</i> 541 (−18 amu) <i>m/z</i> 474 (−85 amu) <i>m/z</i> 84, 167, 195 | Decarboxylated: −28 amu on camptothecin nucleus; modification of the lactone ring | High | Low |
| 6 | 560 | <i>m/z</i> 543 (−18 amu) <i>m/z</i> 476 (−85 amu) <i>m/z</i> 84, 167, 195 | Decarboxylated: −26 amu on camptothecin; modification of the lactone ring | High | nd |
| 7 | 602 | <i>m/z</i> 559 (−CO ₂) <i>m/z</i> 518 (−85 amu) <i>m/z</i> 84, 167, 195 | Oxidation of the camptothecin nucleus | Low | Low |
| 8 | 602 | <i>m/z</i> 559 (−CO ₂) <i>m/z</i> 502 [−(85 + 16) amu] <i>m/z</i> 183 (167 + 16 amu) | Oxidation of terminal piperidine | High | High |

| | | | | | |
|----|-----|---|--|------|------|
| 10 | 618 | m/z 575 (-CO ₂) m/z 502 [- (85 + 32) amu] m/z 393 [(SN-38 + H) ⁺] m/z 349 (393-CO ₂) m/z 227 (195 + 32 amu) m/z 393 [(SN-38 + H) ⁺] m/z 349 (393-CO ₂) m/z 99, 127 | Double oxidation of terminal piperidine | High | High |
| 11 | 518 | m/z 557 (-18 amu) m/z [- (85 + 16) amu] m/z 183 (167 + 16 amu) m/z 559 (-CO ₂) m/z 518 (-85 amu) m/z 84, 167, 195 | Loss of terminal piperidine | High | High |
| 12 | 574 | m/z 557 (-18 amu) m/z [- (85 + 16) amu] m/z 183 (167 + 16 amu) m/z 559 (-CO ₂) m/z 518 (-85 amu) m/z 84, 167, 195 | Oxidation of terminal piperidine of metabolite 5 | High | nd |
| 13 | 602 | m/z 559 (-CO ₂) m/z 518 (-85 amu) m/z 84, 167, 195 | Oxidation of the camptothecin nucleus | Low | Low |
| 14 | 574 | m/z 557 (-18 amu) m/z 474 [- (85 + 16) amu] m/z 183 (167 + 16 amu) No data obtained | Oxidation of terminal piperidine of metabolite 5 | Low | nd |
| 15 | 490 | No data obtained | Could correspond to metabolite 11 with the lactone ring of CPT-11 modified as metabolite 5 | Low | nd |
| 16 | 574 | m/z 557 (-18 amu) m/z 490 (-85 amu) m/z 84, 167, 195 | Oxidation on camptothecin nucleus of metabolite 5 | Low | nd |

Source: Reprinted with permission from Lokiec et al., 1996. Copyright 1996 American Association for Cancer Research.

Note: nd, not detected.

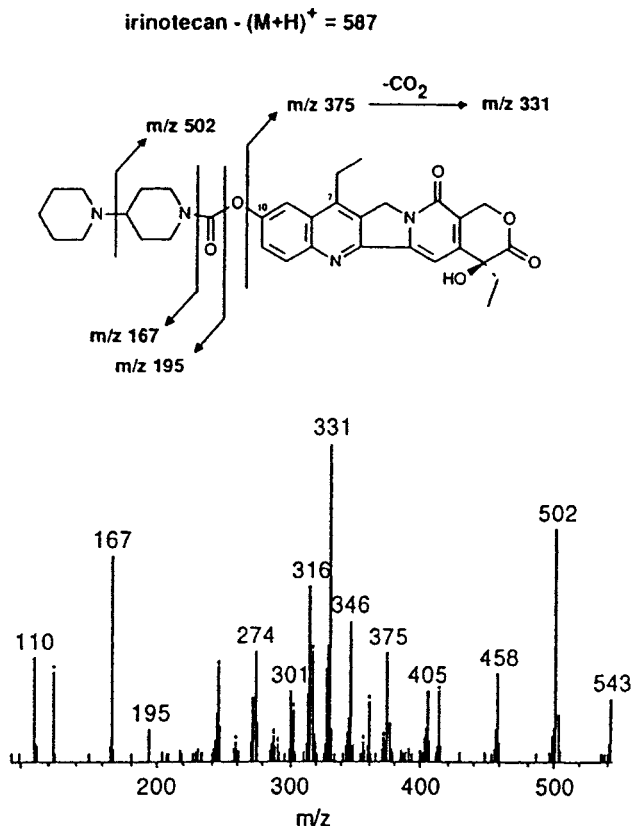

Figure 6.42 Product ion spectrum of CPT-11, the structural template for the identification of metabolite structures. (Reprinted with permission from Lokiec et al., 1996. Copyright 1996 American Association for Cancer Research.)

bipiperidine side chain is the major metabolic pathway. In addition, metabolism of CPT-11 occurs on three sites: (1) decarboxylation of the lactone ring, (2) oxidation of the camptothecin nucleus or of the 7-ethyl group, and (3) multiple oxidations of the bipiperidine side chain. The information obtained from this study provides a clear indication that oxidative metabolism plays an important role in the elimination of CPT-11.

Degradant Identification

Volk and co-workers described the use of LC/MS approaches for the identification of butorphanol degradants present in LTSS samples

during the clinical development stage (Volk et al., 1996). Butorphanol, the active ingredient in Stadol NS, is formulated as an intranasal analgesic product and is used in the treatment of the pain associated with postsurgical situations, dental intervention, and migraine (Lippman et al., 1977; Zeedick, 1979). Careful monitoring of degradant formation is an important aspect in determining the stability of the drug. Identification of the degradants is useful for determining potency and providing insight into improved formulations.

In this study, several low-level degradants are observed in the HPLC/UV chromatogram. Using a standard method LC/MS-profiling protocol, structural and substructural data for trace, butorphanol-related components were obtained rapidly and systematically in the formulated drug without prior fractionation. Similar to the analysis strategies described for metabolite and impurity identification, chromatographic resolution of coeluting or unresolved components is not required to obtain product ion data for structural analysis, due to the mass-resolving capability of mass spectrometry. As a result, this analysis strategy permits the development of an LC/MS-based butorphanol degradant database that includes relative retention time, molecular weight, and product ion spectra.

The degradation pathway and LC/MS profile data are summarized in Figure 6.43. These results indicate the degradative processes observed for the LTSS samples of butorphanol tartrate: oxidative products proposed as 9-hydroxy and 9-keto-butorphanol, norbutorphanol, a ring-contraction degradant, and $\Delta 1,10a$ butorphanol. In less than one day, detailed structural information regarding trace level components in the stability samples is obtained. When this information was correlated with known or predicted chemically labile portions of the molecule, structures were rapidly proposed. As a result, synthesis of the proposed degradants and subsequent confirmation occurred much sooner than with the traditional structure identification strategies.

Degradant structures are identified with the product ion spectrum of butorphanol as a structural template. The subsequent product ion spectra obtained for each degradant represent a unique fingerprint of each compound and can be used for structure identification purposes and for confirmation of the presence of a suspected component. A database of degradant structures is constructed from the resulting data (Table 6.20) or referenced to an existing database assembled during the preclinical development stage. Thus, the

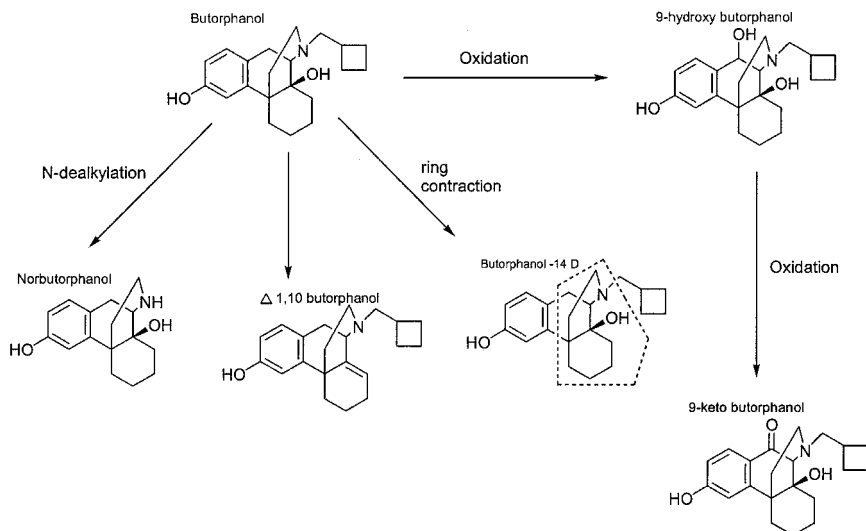
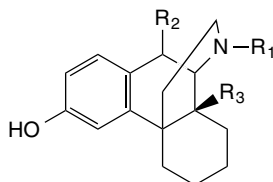

Figure 6.43 Degradation pathway for butorphanol tartrate in long-term stability samples (LTSS). The dashed area indicates the substructure involved in the proposed ring contraction. (Reprinted with permission from Volk et al., 1996. Copyright 1996 Elsevier.)

TABLE 6.20 Butorphanol degradants from long-term stability storage of an aqueous formulation identified with LC/MS and template structure analysis



| Proposed Structure | RRT | Molecular Weight | R ₁ | R ₂ | R ₃ |
|-----------------------------|------|------------------|---|----------------|----------------|
| Norbutorphanol | 0.58 | 259 | H | H | OH |
| Hydroxy-butorphanol | 0.78 | 343 | —CH ₂ (C ₄ H ₇) | OH | OH |
| Ring-contracted butorphanol | 0.90 | 313 | —CH ₂ (C ₄ H ₇) | H | OH |
| Butorphanol | 1.0 | 327 | —CH ₂ (C ₄ H ₇) | H | OH |
| Keto-butorphanol | 1.3 | 341 | —CH ₂ (C ₄ H ₇) | =O | OH |
| Δ1, 10a-butorphanol | 1.5 | 309 | —CH ₂ (C ₄ H ₇) | H | H |

Source: Reprinted with permission from Volk et al., 1996. Copyright 1996 Elsevier.

comparison of degradant product ion spectra with the butorphanol structural template allows for a rapid and systematic approach for identification.

MANUFACTURING

Once the NDA is approved, attention shifts to issues that relate to the reliable production, packaging, storage, and distribution of the drug. Quality assurance of the drug product for human use is of highest concern. Regulatory agencies provide intense oversight of the manufacturing and of patient side effects. When new impurities or degradants appear, a major effort is invested in identifying the source and in generating an appropriate remedy to the situation. During this stage, the development and maintenance of good relationships with regulatory agencies is of great importance.

Analysis Requirements. Clinical supplies must pass rigid specifications established during earlier stages. When a product is no longer within specifications (i.e., failure), a tremendous amount of analytical work goes into characterizing the impurity. These situations may arise from many events, such as an unexpected process reaction, failure of a cleanup step, or contamination from a packaging material. Competitive analysis can involve the assessment of advantageous characteristics, such as stability. It can also involve the accumulation of information regarding patent infringement.

Analysis Perspectives. Most manufacturing analyses focus on the routine monitoring of highly characterized products. Quality assurance analysis of a drug can involve the monitoring of 5 to 20 impurities, and the monitoring of a biologically derived drug can involve amino acid sequence verification and the monitoring of variant structural forms. When troublesome situations arise because of the introduction of a new impurity in the drug product, intense efforts are invested in identification and quantitation procedures so that the cause can be rapidly addressed and eliminated from the manufacturing process. Prompt action can maintain an excellent relationship with regulatory agencies and can lead to significant savings.

LC/MS Contributions. HPLC with UV detection is used throughout the pharmaceutical industry and is often the technique by which manufacturing issues are first identified. The transfer of this analysis

to the LC/MS is, therefore, useful for organizational collaboration. During this development stage, structural information is readily correlated with HPLC peaks observed in the QC laboratory. Thus, LC/MS is particularly suitable for troubleshooting studies. The inherent sensitivity, selectivity, and speed of LC/MS allow the rapid production of information. The structural information from LC/MS is often sufficient for the rapid assessment of the source and extent of the problem. The sensitivity and selectivity of LC/MS allows for the facile application to trace impurities in complex samples.

Overview. This section of the chapter illustrates the application of LC/MS, featuring data-dependent analysis techniques for the identification and quantitation of contaminants from drug product packaging (Tiller et al., 1997a). In the past, leachables from packaging materials have appeared as impurities in drug product QC monitoring. Identification and quantitation of these leachables with LC/MS can provide information for the selection of suitable materials. The application of LC/MS for the monitoring of biologic drugs (Chang et al., 1997) is also described. The amino acid sequence can be confirmed, and impurities due to other sequences or posttranslational modifications may be monitored. Each example highlights the unique capabilities of LC/MS during this final stage of drug development (Table 6.21). The use of LC/MS methods for identifying impurities and degradants in support of patents is also an important aspect of the manufacturing stage. Similar strategies as described for preclinical development support are used, and the resulting LC/MS structure profiles that are obtained from samples in the field are compared to in-house reference standards. To illustrate the use of LC/MS for this application, the identification of trace impurities in cimetidine drug substance is described (Eckers et al., 1997).

TABLE 6.21 Representative applications of LC/MS in manufacturing

| Manufacturing Activity | Analysis | LC/MS Application | Selected References |
|-------------------------|-----------------------------------|-------------------------|---------------------|
| Production | Impurity identification | Data dependent analysis | Tiller et al., 1997 |
| Quality control | Protein characterization | Peptide mapping | Change et al., 1997 |
| Legal/patent protection | Impurity/degradant Identification | Impurity profiling | Eckers et al., 1997 |

Impurity Identification Using Data-Dependent Analysis

Regulatory authorities strictly scrutinize the leachables (e.g., plasticizers, impurities) that may come from medical devices and drugs. It is the responsibility of the drug or medical device company to identify the leachables and to provide adequate testing of their toxicity. Monitoring methods must be developed and validated to effectively control toxic leachables during the manufacture of high quality pharmaceuticals.

As a result, materials for medical devices and drug products must be tested for leachable components. Once a known toxic compound is discovered, it must be identified for the assessment of toxicity, followed by the monitoring of levels using validated methods as required by the FDA. This identification procedure could be a time-consuming process with traditional methods that are based on fractionation and individual component analysis.

Tiller and co-workers have demonstrated an analytical strategy with on-line LC/UV/MS and LC/MS/MS to rapidly obtain structural information for leachables from a drug-delivery device (Tiller et al., 1997a). The analysis strategy makes use of data-dependent analysis, wherein the mass spectrometer first obtains molecular ions using full-scan techniques, and makes real-time decisions about MS/MS product ion spectra that must be obtained. In this way, molecular weight and substructural information are both obtained for many components during a single HPLC run.

In the Tiller study, adhesive was applied to a glass bottle and cured. Highly purified water was placed over the adhesive, heated at 50°C for 3 days, and analyzed with gradient reversed-phase HPLC. An LC/ITMS with ESI was used to profile the polyesters in the adhesive extracts with full-scan mass spectra and corresponding product ion spectra triggered by an ion abundance that surpassed a threshold.

Many components are readily observed in the ESI-LC/MS chromatogram, and several polyester leachables were identified (Figure 6.44). The ESI LC/MS chromatogram revealed 15 components, compared to the three components that were observed in the 220 nm UV chromatogram. This difference illustrates the capability of ESI-LC/MS to provide a more universal detection when the analytes do not contain strongly UV-absorbing substructures (e.g., aromatic). The method is highly efficient because molecular weight and substructural information from the full-scan and product ion experi-

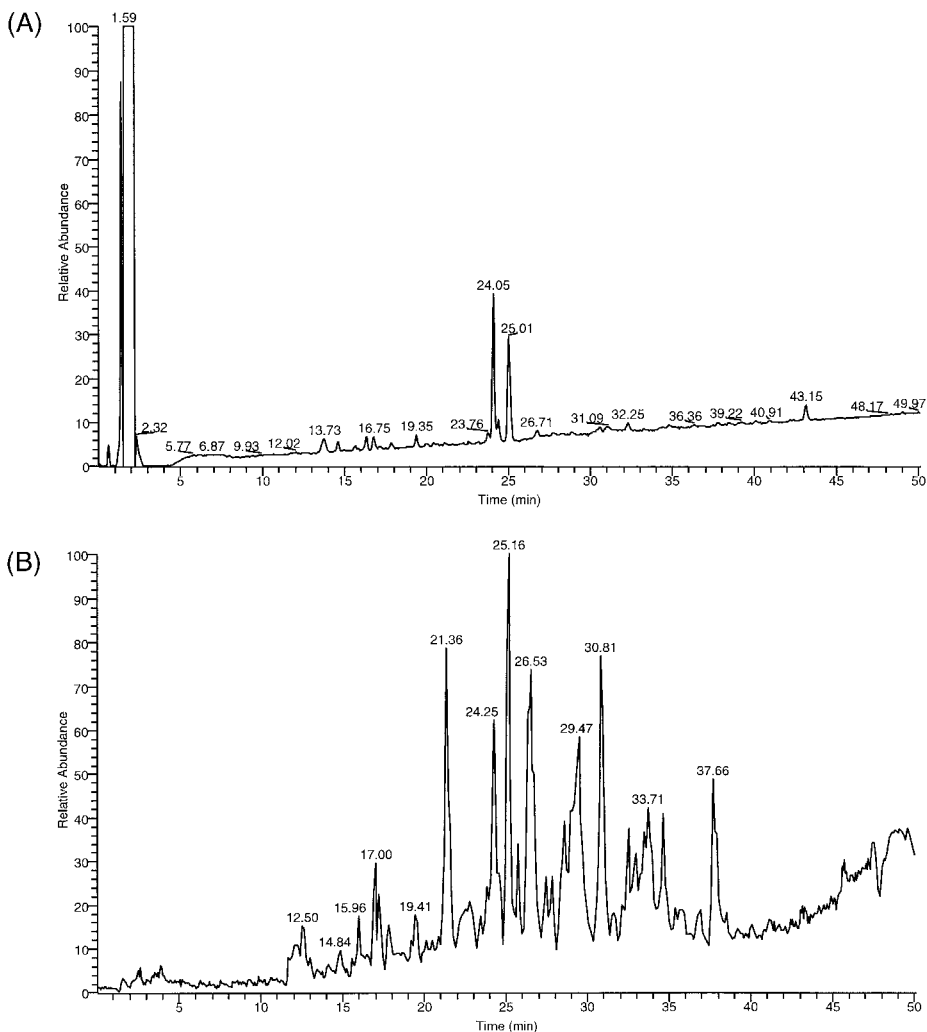

Figure 6.44 Chromatograms from the LC/UV/ion trap MS analysis of leachables that were extracted from a test adhesive with deionized water at 50°C for 3 days. (A) UV chromatogram at 220 nm. (B) TIC full-scan MS chromatogram. (Reprinted with permission from Tiller et al., 1997a. Copyright 1997 John Wiley & Sons.)

ments, respectively, are both obtained for the sample components. Figure 6.45 shows the full-scan mass spectrum and the product ion spectrum obtained from the peak at 25.16 min. A molecular weight of 472 is easily confirmed due to the presence of the $[M+H]^+$ ion at

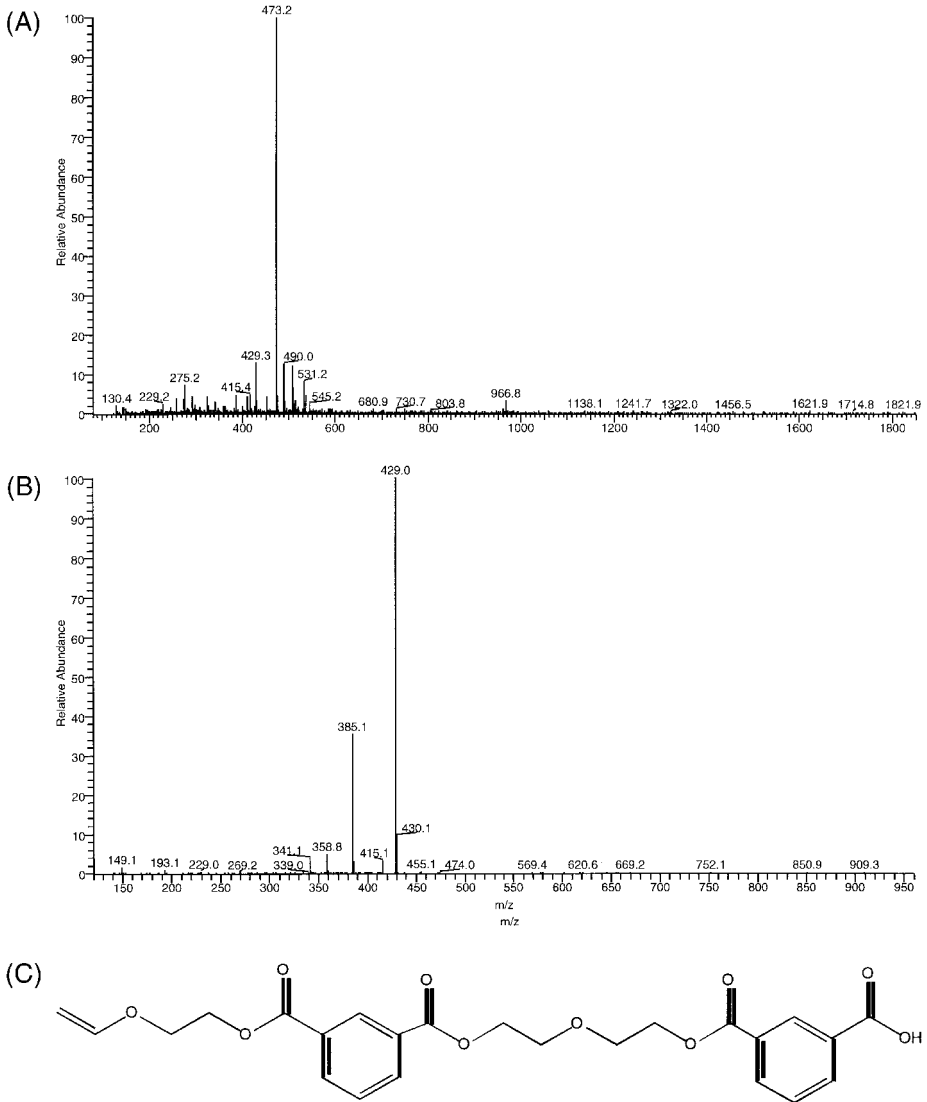

Figure 6.45 Mass spectra of the leachate component eluting at 25.16 min. (A) Full-scan mass spectrum of component. (B) Product ion spectrum of m/z 473. The proposed structure is the reaction product between two isophthalic acid molecules with two diethylene glycol molecules to form the compound shown in (C). (Reprinted with permission from Tiller et al., 1997a. Copyright 1997 John Wiley & Sons.)

m/z 473 and the ammonium adduct $[M+NH_4]^+$ at m/z 490. With this information and knowledge of the starting materials, a reaction product of 2-isophthalic acid molecules with two diethylene glycol molecules was proposed (Figure 6.45C). The product ion spectrum contains the ions at m/z 429 and 385, which correspond to two successive losses of either C_2H_4O or CO_2 from the protonated molecular ion to yield the m/z 429 and 385 product ions, respectively.

Similar to previous structure identification methods described for metabolites, impurities, and degradants, the knowledge of the physiological or chemical process, in this case the adhesive synthesis process, helped in the rapid interpretation of the MS/MS spectra of the unknown components. No user input about the sample composition is needed for the data-dependent analysis scheme; thus, these experiments are simple and rapid to perform. The result is a fairly routine approach to structural screening of unknown mixtures during the manufacturing stage.

A report by Wu and co-workers highlighted the importance of similar LC/MS-based procedures to identify organic extractables from rubber stoppers in biotech products (Wu et al., 1997). The capability of analyzing the extractables from mixtures of a peptide drug along with its formulated excipients allowed for the detection of butylated hydroxytolulene to the 0.1 ppm level. Furthermore, the presence of a coeluting polymer highlighted the advantages of on-line LC/MS-based approaches.

Peptide Mapping in Quality Control

Quality control involves a carefully designed series of analysis and protocols. The purpose of this activity during the manufacturing stage of drug development is to ensure the production of safe, high quality drug products. These measures are helpful for the producers of the product as well as the regulators (i.e., the Food and Drug Administration). In this way, adherence to protocols and procedure are carefully monitored on a routine basis. When any uncertainty in the manufacturing process occurs, procedures are referenced and data are analyzed to determine the specific stage of manufacturing to begin examining. Thus, the responsibility of drug manufacturers and regulating agencies is to determine *when* and *how* a process went awry. The ability to do so in an efficient, straightforward manner is helpful to both parties, and ultimately, the consumer. Thus, the ability

to provide this information is highly dependent on the manufacturer's ability to control the process.

LC/MS-based approaches provide the same analytical benefits during the manufacturing stage of drug development as described for earlier stages. Information relating to process (i.e., retention time, molecular weight, and structure) obtained during manufacturing help to accelerate drug development. LC/MS analysis of protein digests provides a powerful tool for mapping peptides and for assuring quality during the manufacturing process. Furthermore, the characterization of minor components contained in the digest may provide information on degradative processes (deamidation, oxidation, proteolysis), incorrect folding and disulfide rearrangement, and errors in translation by the host cell.

Somidobove is a recombinant bovine growth hormone (rbST) composed of 199 amino acids with a MW 22,818. It is used to treat lactating dairy cows for increased milk production. Chang and co-workers described the use of LC/MS as a routine peptide-mapping tool to examine the amino acid sequence of the protein molecule during manufacturing (Chang et al., 1997). The peptides generated from the tryptic digest of somidobove provide a diagnostic confirmation of the primary structure and an important aspect of quality control.

The use of LC/MS in a quality control environment with biologicals involves three steps. First, the expected cleavage sites (in this case, trypsin) within the amino acid sequence of the protein somidobove are indicated in Figure 6.46. This tryptic map serves as a template for the expected peptide map. Second, an analytical method using chromatography columns and conditions that provide the best resolution and reproducibility is developed. An opportunity exists to optimize the analysis based on chromatography, digestion, and LC/MS performance. Finally, the resulting LC/MS data are profiled, according to amino acid sequence, peak number, and $[M+H]^+$, as shown in Figure 6.47. Other properties such as relative retention time can also be added in this format.

This LC/MS approach is analogous to the strategies employed during earlier phases of drug development. Rigid protocols result in a tight control of the process and an adherence to desired specifications. Similarly, the LC/MS screening approaches provide a measure of control as well, to ensure the efficient harvesting of discovery and the detection of serendipity.



Figure 6.46 Amino acid sequence of somidobove, which serves as a template for the expected peptide map. (Reprinted with permission from Chang et al., 1997. Copyright 1997 John Wiley & Sons.)

Patent Protection

As previously discussed, the analysis of trace amounts of impurities often precludes the use of other spectroscopic techniques such as NMR due to time-consuming sample preparation procedures. LC/MS approaches that feature triple quadrupole (Volk et al., 1996;

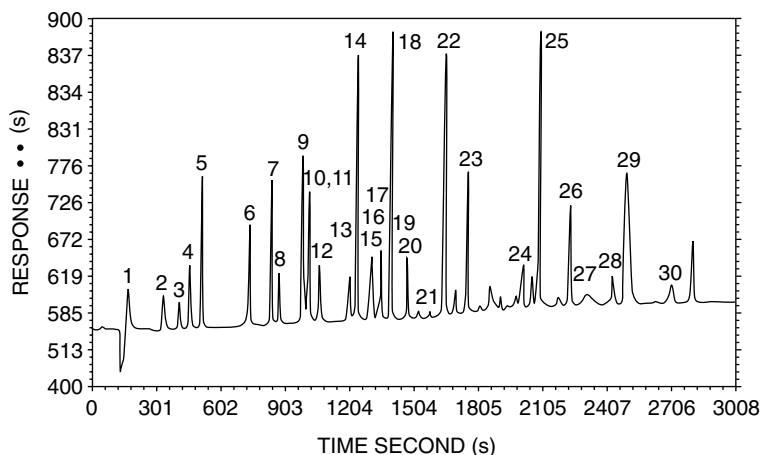

Figure 6.47 Somidobove LC/MS tryptic peptide mapping. (Reprinted with permission from Chang et al., 1997. Copyright 1997 John Wiley & Sons.)

Nicolas and Scholz, 1998) and ion trap mass (Tiller et al., 1997a) spectrometers have been benchmarked as a routine tool for the characterization of trace impurities in drug substances.

The analysis of drug substance for impurities is generally initiated with HPLC-UV experiments run under standard chromatographic conditions. The chromatogram of a known batch of drug substance creates a signature of the material (active component and corresponding impurities) that is indicative of the proprietary synthetic pathway. Comparison of specific manufacturing batches of adulterated or counterfeit materials with the known standard batch of drug substance is performed routinely for impurities (0.1%). A qualitative match of chromatographic peaks based on retention time is used to deduce whether a patent has been infringed.

When a new peak(s) is observed in the HPLC chromatogram, LC/MS is used with the identical chromatographic method to identify the suspected impurity. Studies that involve the use of a QTOF mass spectrometer format highlight the benefit of enhanced sensitivity and accurate mass measurement for the identification of trace components (Eckers et al., 1997). The HPLC-UV chromatogram and mass chromatograms corresponding to the protonated molecules of the suspected impurities are typically plotted as shown in Figure 6.48. The mass spectra of each impurity contain protonated molecular ions with little fragmentation. Due to the high resolution capa-

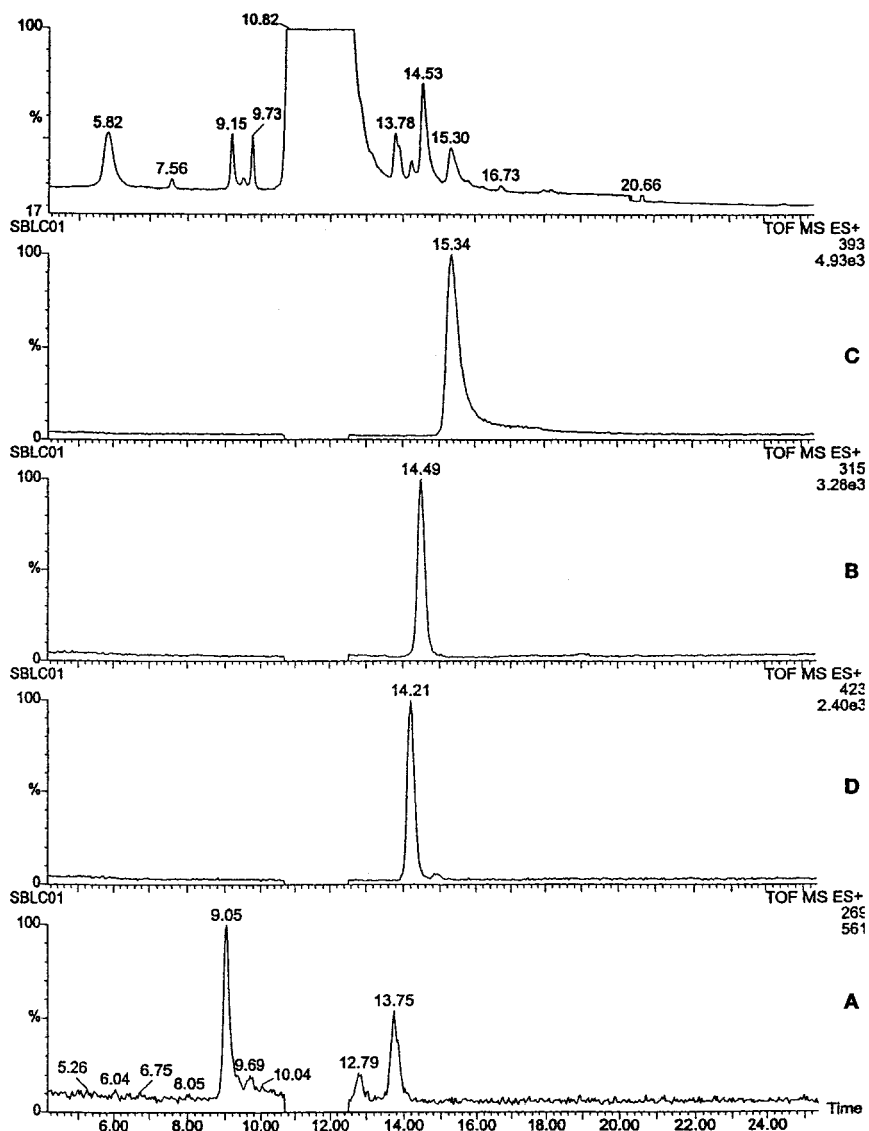
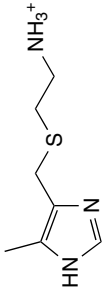
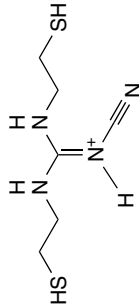
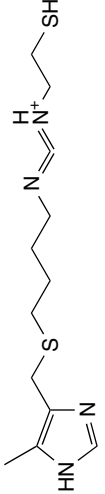
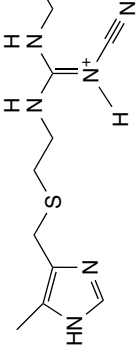

Figure 6.48 The HPLC-UV (230 nm) (top trace) and mass chromatograms of impurities (A–D). (Reprinted with permission from Eckers et al., 1997. Copyright 1997 John Wiley & Sons.)

bilities of the QTOF format, an accurate mass is obtained. Product ion mass spectra are obtained for each impurity to confirm or deduce structure. Since most impurities contain the core structure of the parent drug, the resulting product ion mass spectra contain some of

TABLE 6.22 Substructure analysis data indicating the structures of the fragment ions with their experimentally determined mass, calculated accurate mass, and parts per million error

| Nominal Mass | Structure | Formula Calculated Mass | Experimental Mass | ppm |
|--------------|---|----------------------------------|-------------------|-----|
| 172 |  | $C_7N_3SH_{15}$ 172.0908 | 172.0916 | 4.4 |
| 205 |  | $C_6N_4S_2H_{17}$ 205.0582 | 205.0585 | 1.6 |
| 257 |  | $C_{10}N_4S_2H_{17}$ 257.0895 | 257.0900 | 2.1 |
| 299 |  | $C_{11}N_6S_2H_{19}$ 299.1113 | 299.1124 | 3.8 |

Source: Reprinted with permission from Eckers et al., 1997. Copyright 1997 John Wiley & Sons.

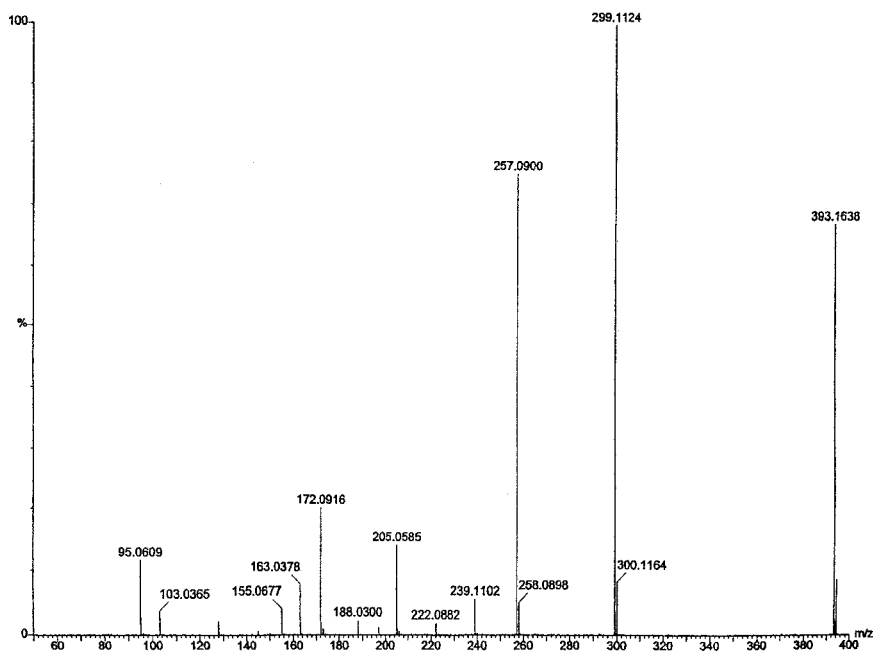

Figure 6.49 The product ion mass spectrum of m/z 393 that corresponds to impurity D. (Reprinted with permission from Eckers et al., 1997. Copyright 1997 John Wiley & Sons.)

the same product ions and corresponding neutral losses. The product ion mass spectrum of impurity D is shown in Figure 6.49. Accurate mass measurements and parts per million error are obtained for each product ion. Molecular formulas are calculated for each experimentally determined mass. This information along with the corresponding substructures is shown in Table 6.22. Comparison of the impurity fragmentation profile with the parent drug template allows for comprehensive assembly (or comparison) of unique substructures. The use of a QTOF format provides an extremely powerful platform for impurity analysis, particularly when authentic standards are unavailable.

CHAPTER 7

FUTURE APPLICATIONS AND PROSPECTS

With a perspective on recent LC/MS applications that illustrated contributions to the acceleration of drug development, new insights may be derived to speculate on future prospects. Certainly, pharmaceutical analysis has evolved and has resulted in the continual development of LC/MS-based technologies and applications. In fact, these improvements have led to novel applications that constitute a major factor for industry acceptance. Pharmaceutical industry applications seem to follow an iterative cycle that emphasizes high throughput, sensitivity, and structural detail. Current trends highlight the growing importance of structural information and a waning perception of LC/MS as a specialized or difficult analysis. A perspective on future applications of LC/MS in drug development is presented with an emphasis on integrated sample generation and analysis activities.

WORKSTATIONS

Workstations are perhaps a more flexible complement to a robotics method. These systems are capable of in-series or parallel analysis. Methods are developed with very specific and specialized functions that allow higher throughput and operation in a batch mode. These dedicated approaches would seem to be a popular choice in the drug discovery and preclinical development stages. Workstations could be

configured according to specialized needs and easily interchangeable with changes in workload or priorities. Since the testing in these areas of drug development are less rigorous (i.e., method validation, quality control [QC]) than in clinical development and manufacturing, overall analysis speed is enhanced. A batch mode process allows for relatively simple correction without catastrophic errors or delays. In any case, each approach seems to focus on opportunities to optimize the human interface during analysis. The robotics approach emphasizes integrated analyses and provides a mechanism to eliminate tedious processes manually performed by a scientist. A workstation approach highlights rapid, diverse analyses where a corrective action can be taken immediately if the LC/MS method is not performing as expected. This approach would favor situations where constantly changing priorities create demands on sample analysis and instrument flexibility.

Automated approaches to LC/MS will play a major role in the future development of dedicated workstations. Robotic systems allow for the integration of many processes (i.e., sample preparation, separation, analysis) in virtually any format. Once set up and properly configured, these systems can perform the analysis with little or no operator intervention. Analyses are either performed in series as samples are individually or sequentially passed through the configuration or off-line in a batch mode. These approaches would appear to be well suited for clinical development and manufacturing activities, where the analysis is fairly uniform and repetitive. The most critical oversight is provided during the method development and method validation stages. It can be expected that similar approaches will be adopted in the early stages of drug development as sample-generating technologies continue to mature and standard formats become established.

The prospects for the application of open-access LC/MS support strategies beyond combinatorial and medicinal chemistry appear to be good. Areas such as process chemistry optimization could benefit tremendously and provide accelerated development for chemical scale-up campaigns (Storer, 1996); therefore, it is likely that similar LC/MS methods will be required (Cepa and Searle, 1998). Extensions of these approaches can be envisioned to include selection of salt form as well as toxicology, solubility, and lipophilicity applications. Once accepted, routine and highly integrated quantitation approaches (Figure 7.1) as described by Cole and colleagues

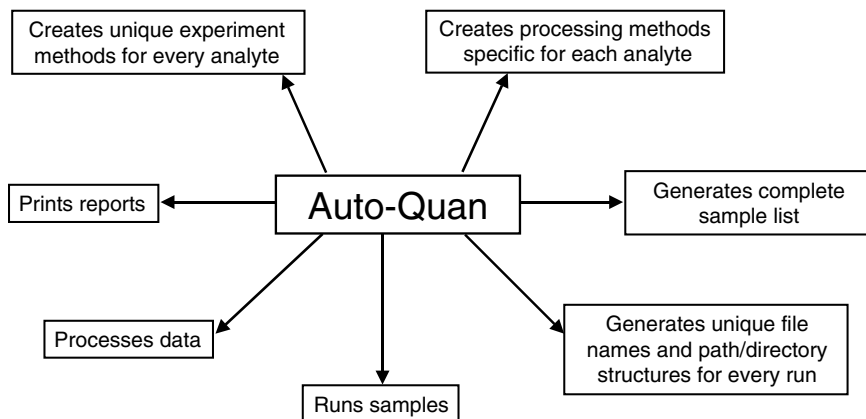

Figure 7.1 An automated quantitation approach that performs all of the necessary tasks required in a quantitative analysis. The user supplies only the molecular ions of the analytes and internal standards. (Cole et al., 1998).

(Cole et al., 1998) are likely to become more widespread. Instrument formats that feature high resolution chromatography and/or mass spectrometry may provide the required structural detail in some instances. Similar to small molecule analysis, the widespread use of open-access LC/MS systems for protein synthesis activities (Burdick and Stults, 1997) appears to be imminent.

Screening applications appear to be logical and necessary. LC/MS-based approaches will likely continue to be a first choice analysis to overcome important bottlenecks for several reasons. First, the quantities of compounds (drug and target) available for drug development will continue to decrease. For example, the amount of compound contained in a single combinatorial bead is usually approximately several hundred picomoles. Second, miniaturization and scale-down methods will become popular strategies to screen compounds, gather data, and improve product and processes in a cost-effective manner. Small-scale experiments reduce the amount of compound/reagents and provide opportunities to explore new avenues of development. Finally, new screening approaches will continue to be desirable in areas that feature trace mixture analysis. The use of LC/MS to directly gather data from mixtures will reduce sample preparation steps for fractionation and purification and will help alleviate the stress brought about by the increased number of targets and compounds that require analysis.

MULTIDIMENSIONAL ANALYSIS

Certainly, screening-based strategies can be extended to include multidimensional separations or multiple stages of mass analysis (i.e., LC/LC/MS/MS, LC/MSⁿ). The integration of expanded capabilities to increase performance will continue to impact chromatography and mass spectrometry formats. A recent example that highlights the benefits of multidimensional chromatography approaches (LC/LC) may provide uniquely integrated capabilities for protein analysis (Link et al., 1999), target-based screening in drug discovery (Hsieh et al., 1997), glycosylation profiles (Apffel et al., 1996), on-line sample extraction (Needham et al., 1998), and integrated approaches for sample cleanup (Sharma et al., 1997). Novel high performance liquid chromatography (HPLC) formats that feature short analysis times (Romanyshyn et al., 2001; Wu et al., 2001) will likely continue to generate interest for discovery screening applications. New applications that feature novel mass spectrometry formats also have exciting potential. The studies performed by Hopfgartner and co-workers illustrate the use of a tandem quadrupole time-of-flight (TOF) instrument to obtain exact mass measurements on drug metabolites (Hopfgartner et al., 1998). The highly automated MS/MS-based approaches for real-time structure identification described by Yu and colleagues (Yu et al., 1999) are a significant step toward an integrated sample analysis with virtually no operator involvement. Furthermore, the possibilities for routine and/or data-dependent MSⁿ protocols for structure identification are an exciting development for the detailed analysis of unknown compounds such as natural products (Gilbert and Lewer, 1998) and metabolites (Lopez et al., 1998).

Although multidimensional LC/MS approaches will continue to expand with powerful and unique capabilities for pharmaceutical analysis, emerging areas of drug development will likely benefit from benchmarked applications. For example, the in-process monitoring and testing of raw materials in bacterial or mammalian cell culture would appear to be logical extension of current applications for chemical process scale-up. In this case, LC/MS can be used to determine the optimum time points to harvest the product. Further QC applications of LC/MS are envisioned that deal with the characterization of product lots for consistency and specifications. An important aspect is the assessment of purity in the presence of inherent microheterogeneity, which is characteristic of biologics derived from bacterial or mammalian cell culture. Performance aspects of chro-

matographic separations, particularly for the mapping of posttranslational modifications, will be important considerations.

The combined use of LC/MS and LC/NMR [nuclear magnetic resonance] shows promise for expanded multidimensional analysis formats. Rapid structure profiling with unambiguous identification of drug compounds is attained with this combination. This combination has already made a significant impact on the drug development cycle with regard to the analysis of combinatorial chemistry mixtures (Holt et al., 1997), metabolites (Shockcor et al., 1996; Shockcor et al., 2000; Mutlib et al., 1995), and degradation products in dosage formulations (Peng et al., 1999). The MS/NMR-based studies performed by Moy and colleagues (Moy et al., 2001) demonstrated the use of this format for high throughput screening applications. This format was demonstrated to provide compelling advantages for the identification of the binding site on the protein and the identification of bound protein-ligand complexes.

MINIATURIZATION

A 96-well plate format has been the standard for drug screening over the past 10 years (Babiak, 1997), and miniaturized formats using a 384-well plate and still smaller ones have begun to appear in the pharmaceutical industry (Kolb and Neumann, 1997). It is likely that these formats, or a derivative, in combination with the LC/MS assay will provide the necessary throughput for liquid handling of samples (Wells 1999a, 1999b).

Approaches to miniaturize or scale-down the pharmaceutical analysis will be popular. For example, pooling strategies are an effective method to alleviate the problems associated with high-volume liquid handling and analysis. This approach has been used to test closely related compounds such as a series of analogs in drug discovery (Hop et al., 1998). Recent compound pooling strategies developed for testing combinatorial libraries (Devlin et al., 1996; Wilson-Lingardo et al., 1996) would appear to be well-suited for many LC/MS-screening approaches. A matrix-pooling strategy involves a 10×10 matrix of separate compounds pooled in the x - and y -directions. The result is 20 sets that contain 10 compounds each. The library size is reduced by a factor of five, and each compound can be tested in duplicate because each compound resides in a x - and y -axis pool. Scale-down approaches that feature predictive

models for metabolic (Rourick et al., 1998) and chemical (Fink et al., 1997) stability are likely to be highly utilized in early development stages. These strategies feature integrated methodologies and parallel processing of complex mixtures that result in multidimensional structural data (Figure 7.2). Scale-down approaches are also likely to be extensively used to provide comparative profiles for metabolism (Gillespie et al., 1998), process impurities (Rourick et al., 1998), degradants (Rourick et al., 1996), cellular uptake (Kerns et al., 1998), and interaction (Lee et al., 1995b).

LC/MS interfaces that accommodate miniaturized formats for biomolecule analysis such as nanoelectrospray (Wilm and Mann, 1996) or microelectrospray (Figeys et al., 1996) with a variety of mass-detection devices ranging from triple quadrupole (Swiderek et al., 1998), TOF (Medzihradzsky et al., 1998), quadrupole TOF (Morris et al., 1996; Hanisch et al., 1998), and ion traps (Figeys and Aebersold, 1997; Arnott et al., 1998) appear to be headed for tremendous growth. Future developments with instrumentation and improvements in performance will drive this growth, which will permit the facile conversion to automated approaches (Ducret et al., 1998) and routine procedures for isotopic labeling of peptides for sequence analysis (Shevchenko et al., 1997; Gygi et al., 1999). Furthermore, it may be reasonable to presume that these advances will result in the more frequent investigations of intact membrane pro-

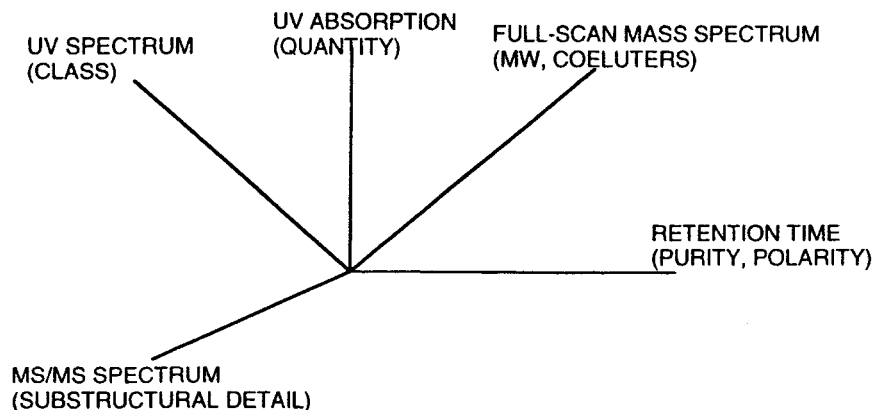

Figure 7.2 Multidimensional structural data produced by predictive models, featuring integrated methods and parallel processing of drug candidates for metabolic (Rourick et al., 1998) and chemical (Fink et al., 1997) stability.

teins (Whitelegge et al., 1998), tRNA (Taniguchi and Hayashi, 1998), and preparative approaches (Immler et al., 1998).

Miniaturized LC/MS formats based on micromachined chip-based electrospray emitters and ionization sources on silicon (Schultz et al., 2000; Licklider et al., 2000; Ramsey and Ramsey 1997; Xue et al., 1997) and plastic (Vrouwe et al., 2000; Yuan and Shiea, 2001, Tang et al., 2001) microchips is a proactive approach for scale-down platforms. Various micromachining processes are used to fabricate these devices. These microanalytical technologies would create integrated sample preparation and LC/MS applications. The potential benefits of such a system include reduced consumption of sample/reagents, low cost, and disposability.

INFORMATION MANAGEMENT

A key area that will continue to emerge with LC/MS applications is data management. With the variety of systems available from benchtops to tandem mass spectrometers, the ability to generate vast amounts of data quickly and easily has created a dilemma for accelerated development activities. Researchers will quickly realize the consequence of data generation and data management. Three factors will help to shape this important area of focus. First, consistency of data will be of significant importance. A consistent data format could involve the separate treatment of raw, processed, and interpreted data. Standard, defined database fields for data entry are essential. Database searching techniques for protein identification (Yates et al., 1998; Yates, 1998b) are likely to expand in scope throughout the drug development cycle. Investigations into similar procedures for the identification of small molecules (i.e., metabolites, impurities, degradants) will be important such as automatic deconvolution (Higgs, 1998) and correlation analysis (Fernandez-Metzler et al., 1999). Second, a relational database to access, compare, and rank data is desirable. Simultaneous comparison of structure, purity, chemical and metabolic stability, lipophilicity, and bioavailability can be made to assist with the drug candidate selection process (Rourick et al., 1998). Third, the continued simplification of data will be a critical step for the continued use and acceptance of LC/MS-based techniques in the pharmaceutical industry. Chromatograms and mass spectra will still have tremendous value and will likely evolve into highly visual and intuitive representations such as contour maps (Li

et al., 1998). However, the interpreted result is a more powerful currency. The visualization of metabolic stability using structures, tables, and graphs are already a standard practice. A picture or number (or groups of each) is still the most the easily understood data for decision makers, regardless of how it was obtained or derived. Visualization approaches are likely to progress from the actual operating system of the instrument to the drug development process.

The growth of information management will likely follow a similar path as traditional sample analysis (i.e., pharmaceutically relevant compounds). The future development of integrated chemical analysis and information analysis will evolve into an increasingly significant component of the application. Thus, the new-age sample will resemble the data format and/or data ensemble. The corresponding instrument will be a dedicated off-line workstation equipped with powerful and unique algorithms. Similar attributes and details (i.e., figure of merit) as practiced with chemical analysis will be defined and will likely involve data preparation, linearity, and correlation, to name a few.

STRATEGIC OUTSOURCING

Historically, the pharmaceutical industry relied almost entirely on internal resources to support drug development. The surge in new technologies has made it difficult to keep current in all areas of responsibility and to maintain adequately trained staff. Due to the availability of high quality research services outside large pharmaceutical companies, many organizations have taken advantage of outsourced analytical services. Similar calculations for full-time equivalent (FTE) described earlier in the accelerated development section indicate that outsourcing is a highly efficient approach for LC/MS analysis. The cost involved with instrument selection, purchase, and installation combined with investments in personnel, training, and maintenance required to generate reliable data have made outsourcing a justifiable, and perhaps, desirable, or even necessary solution.

Outsourcing strategies offer a highly flexible and adaptable strategy for clinical development support. This approach to drug development generally involves the use of contract research organizations (CROs) and contract analytical laboratories, which perform a variety of specialized clinical development-based functions. This practice has

spread throughout the drug development cycle, and it is expected that 20% of pharmaceutical research and development budgets will be spent externally by the year 2000 (Taafe, 1996).

SUMMARY

Analysis will continue to respond to advances in pharmaceutical technologies. Similar to the pharmaceutical industry response to molecular biology technology in the 1970s, where quantity and purification were no longer the bottlenecks for the discovery of new drugs, continued advances in combinatorial chemistry, genomics, and recently, proteomics are likely to lead to significant changes. These changes will necessitate the development of analytical technologies that address the criteria of a dynamic drug development environment.

The repetitive yet diverse nature of drug development suggests that high throughput and automated analysis tools will play a major role. Growth in product pipelines and limitations in analytical capabilities will likely continue to drive the field toward miniaturization. Meanwhile, the traditional methods for analysis continue to lose meaning in many aspects of drug development. For example, the classical approaches of NMR or infrared (IR) are no longer feasible for the analysis of combinatorially derived compounds. Certainly, NMR or IR spectra of a multicomponent library mixture can be obtained; however, they are not yet routinely diagnostic of structure. The loss of these powerful tools creates both burdens and opportunities. Regardless of the applications, the success of LC/MS techniques to drug development will remain closely linked to the integration with distinct drug development activities. The ultimate success is likely to depend on continued collaboration and relationship.

CHAPTER 8

PERSPECTIVES ON THE FUTURE GROWTH OF LC/MS

Many organizations have responded to LC/MS because of some seemingly common motivating factors. These factors provide a perspective as to why LC/MS has become so prominent throughout the drug development cycle and provide unique insights into the future prospects for growth.

Accelerated drug development schemes have shifted the need for analytical instrumentation to include criteria for high throughput (quantitative process approaches) and the capability to contribute to an application that produces information for accelerated decision making (qualitative process approaches). The value of sensitivity, selectivity, and detail are still significant; however, new parameters dealing with *efficiency*, *productivity*, and *information content* have become the new watermarks for analytical instrumentation in the pharmaceutical industry. These factors have been affected by shorter timelines and the pharmaceutically relevant information required for decision making.

Ongoing technological advances have caused relationship building to be a key aspect of growth. Scientists are compelled to seek more depth of knowledge in their primary specialty, yet they are constantly put in an environment that demands broader knowledge, flexibility, relationship skills, and the ability to effectively integrate new technologies. As responsibilities within the pharmaceutical

industry have become broader, interpersonal skills such as the ability to understand needs, create relationships, and develop alliances have become more important.

Today's analytical end users are made up of: (1) researchers who specialize in analysis and (2) researchers from other pharmaceutical specialties. Researchers who specialize in analysis (i.e., analytical chemists) with formal training in the fundamentals of instrumentation, method development, and the treatment of data are continually challenged with relearning the fundamentals of chemistry (Laitinen, 1980) and other pharmaceutical sciences, such as molecular biology. They must keep current with advances in the field as well as the pharmaceutical business in general.

Accelerated development schemes have made scientists more dependent on analytical information, and consequently, they are more apt to want to control or perform analysis activities themselves. No doubt the human factor will inevitably arise and create reluctance, and perhaps, barriers to adopt new approaches. For example, the LC/MS applications that deal with open-access support for combinatorial and medicinal chemistry made aspects of acceptance quite clear. A chemist preferred simple answers to simple questions.

Certainly, scientists within the pharmaceutical industry will continue to be immensely challenged by the introduction of new technologies such as LC/MS and their subsequent application to achieve accelerated development goals. In an effort to make these new technologies user friendly to researchers in nonanalytical specialties, specific tasks are being incorporated into the operating system of the analytical instrument. Still, productivity and efficiency are paramount to success. Future growth will continue to depend on strong relationships with instrument manufacturers and academia.

The pharmaceutical industry will continue to depend on innovative products and highly trained scientists to provide the data to support breakthroughs in medicine. Technologies such as combinatorial chemistry and molecular biology are capable of providing unique information at unprecedented levels. These technologies have been adapted and integrated within the pharmaceutical environment to provide quantitative and qualitative process solutions for drug development. For the academicians and instrument manufacturers, there has been no such breakthrough. Specifically, there has not been an equivalent process-related technology that would significantly accelerate the rate of invention and graduation or the rate of instrument development and manufacturing. Yet the burden of

TABLE 8.1 The elements of the information-gathering process during drug development, based on relationships between the analytical data and decision

| Drug Development Need | Analysis Activity | Data | Currency for Drug Development Decision |
|-----------------------|---------------------------|-------------|--|
| Analysis method | Method development | Raw | Information |
| Analysis strategy | Method/process refinement | Processed | Information/knowledge |
| Analysis solution | Method/process validation | Interpreted | Integrated information/knowledge |

keeping pace with technology and the diverse demands of the end user increases.

In general, progress in drug development depends on data obtained from analytical instruments. Thus, *how* this information is derived and provided to decision makers is critical to the success of the pharmaceutical industry. LC/MS technologies have effectively and uniquely supported the productivity (quantitative processes) and efficiency (qualitative processes) needs of drug development. Future issues appear to be directed toward enhancement of the information-gathering process that focuses on the relationship between data and decision (Table 8.1).

There is no single approach to the selection and implementation of analytical technologies. There will always be variety and diversity in how different organizations accomplish their goals. This approach relates to the organization's history and culture, as well as to the people's areas of expertise and philosophies.

CHAPTER 9

CONCLUSIONS

An impressive variety of LC/MS-based solutions, incorporating quantitative and qualitative process approaches, are now routinely applied to accelerate drug development. The results are significant and led to the successful development of innovative therapies and numerous novel drugs. The use of LC/MS with other technologies for sample preparation, analysis, and data management is now an inextricably linked element of drug development.

The LC/MS applications highlighted in this book indicate that this unique technology is now fundamentally established as a valuable tool for analysis in the pharmaceutical industry. The illustration of a widened scope of application in the pharmaceutical industry, the fifth stage of an analytical method, suggests that LC/MS is establishing itself as a widely accepted and routine tool (sixth stage) for pharmaceutical analysis in all stages of drug development. It appears likely that the balance between research and development needs along with partnership between academia, instrument manufacturers, and industry researchers will allow for the continued acceptance and advancement of LC/MS technologies in the pharmaceutical industry.

However, the pharmaceutical industry is hardly analyst driven. Yet, it is analyst dependent. As new technologies continue to advance, the need for information-rich tools such as LC/MS will increase. A continual change in the top-line business combined with

tremendous focus on the bottom line will indeed challenge many. And, as the pressures also increase with increasing responsibilities of generating the data, managing the laboratory, and using the information, decision makers will need to understand technology and its applications much faster. Of course, relating this understanding to business goals represents an equally significant challenge.

Though many of the developments illustrated in this book are truly unprecedented, we should realize that history does have a tendency to repeat itself. And like the seven stages of an analytical method, significant social events impact drug development. The insightful and powerful statement made by Izaak Kolthoff in 1973 (Kolthoff, 1973) is an eloquent reminder, "We analytical chemists are no longer the maidservants of other chemists, but together we contribute to further progress in the whole field of chemistry." Hopefully, as the basis of understanding application, strategy, and analysis become more complicated and more integrated with drug development, the depth of understanding new technology, process, and collaboration will continue to improve.

GLOSSARY

The glossary provides a list of the terminology and definitions encountered during analysis activities in drug development. The objective is to assist the understanding of principles, concepts, and analysis strategies. The glossary has been assembled in part from the well-accepted definitions obtained from the literature (Nagel et al., 1992; Duffus., 1993). Many of the meanings are derived from an analyst's perspective, specifically, activities that involve LC/MS-based methods.

ADME The abbreviation for absorption, distribution, metabolism, and excretion (*see* pharmacokinetics).

affinity The tendency of one molecule to associate with another.

analog A drug whose structure is related to that of another drug, but whose chemical and biological properties may be quite different.

analytical chemistry The science of chemical characterization and measurement.

application An analytical procedure developed for the production of specific types of data from certain samples.

bioanalysis The measurement of a drug and related structures that are contained in complex matrices, typically at the part per million to part per trillion level.

bioassay A procedure for determining the concentration, purity, and/or biological activity of a drug by measuring its effect on an organism, tissue, cell, enzyme, or receptor as compared to a standard preparation.

biotransformation The chemical conversion of substances by living organisms or enzyme preparations.

chemical manufacture and control (CMC) The section in the investigational new drug (IND) or new drug application (NDA) that contain information on the chemical characteristics of the lead candidate.

chemometrics The application of statistics to the analysis of chemical data and design of chemical experiments and simulations.

clinical development The stage of drug development responsible for registering the drug candidate and filing the new drug application NDA.

clinical trial application (CTA) The equivalent of the investigational new drug (IND) document filed in Europe.

collisionally induced dissociation (CID) The process in which a selected precursor ion undergoes collisions with neutral gas molecules in a collision region to yield product ions.

combinatorial chemistry The process of preparing large sets of organic compounds by combining sets of building blocks.

combinatorial library A set of compounds prepared by combinatorial chemistry.

de novo design The design of bioactive compounds by the incremental construction of a ligand model within the receptor or enzyme active site.

degradant A drug analog formed from the drug as a result of the action of chemical and/or physical conditions.

dereplication A process of rapidly identifying known compounds contained in a natural products extract.

double-blind study A clinical study of potential and marketed drugs where neither the investigators nor the subjects knows which subjects will be treated with the active principle and which ones receive a placebo.

drug Any substance presented for treating, curing, or preventing disease.

drug discovery The stage of drug development responsible for generating and optimizing lead compounds.

drug disposition Refers to all the processes involved in absorption, distribution, metabolism, and excretion of drugs in a living organism.

drug product The manufactured formulated drug appropriate for clinical studies.

drug substance The manufactured drug compound appropriate for formulation into drug product.

efficacy The success of the drug in alleviating a targeted disease in humans.

electrospray ionization (ESI) The liberation of ions from electrically charged droplets in an atmospheric pressure ionization source region.

extracted ion current profile (EICP) The mass spectrometry signal that corresponds to an ion plotted versus time. Also referred to as a mass chromatogram.

Food and Drug Administration (FDA) The government agency responsible for instituting policies and monitoring science to ensure safe, high quality pharmaceutical products.

Fourier transform ion cyclotron resonance mass spectrometer This type of mass spectrometer consists of an ion cyclotron resonance (ICR) analyzer cell situated in the homogeneous region of a large magnet. The ions introduced into the ICR analyzer are constrained (trapped) by the magnetic field to move in circular orbits with a specific frequency that corresponds to a specific mass-to-charge ratio (m/z). Mass analysis occurs when radiofrequency (rf) potential is applied (pulsed) to the ICR analyzer so that all ions are accelerated to a larger orbit radius. After the pulse is turned off, the transient image current is acquired and a Fourier transform separates the individual cyclotron frequencies. Repeating this pulsing process to accumulate several transients is used to improve the signal-to-noise ratio.

full-time equivalent One full-time employee with skills and productivity appropriate to the designated responsibilities.

gas chromatography/mass spectrometry (GC/MS) An analytical instrument that integrates a gas chromatograph with a mass spectrometer.

genome The complete set of chromosomal and extrachromosomal genes of an organism, a cell, an organelle, or a virus. The complete DNA component of an organism.

genomics The study of the relationship of specific genes to the expression of certain proteins or biological functions (e.g., disease).

good laboratory practice (GLP) The regulations and requirements for the operation of laboratories that produce data used for regulatory filings.

good manufacturing practice (GMP) The regulations and requirements for validation, personnel, and record keeping of facilities associated with making drug products administered to humans.

high performance liquid chromatography (HPLC) A technology in which compounds are partitioned between a stationary media and a flowing liquid phase in a tubular format under high pressure, resulting in the separation of a mixture of components and the reproducible time of elution of each specific compound.

homolog A compound that belongs to a series of compounds that differ from each other by a repeating unit, such as a methylene group or a peptide residue.

impurity An extraneous compound present in a drug substance or drug product.

investigational new drug (IND) The registration document filed to begin testing in humans.

ion trap mass spectrometer This device consists of two endcap electrodes (entrance and exit) and a ring electrode. An ion trap mass spectrometer separates ions based on mass-to-charge ratio (m/z). Once ions are introduced into the ion trap mass spectrometer, the radiofrequency (rf) amplitude is increased so that ions are sequentially ejected (by increasing mass) and detected. This type of mass spectrometer provides a routine (i.e., benchtop) and sensitive detector using either gas chromatography (GC) or liquid chromatography (LC) interfaces. Furthermore, this instrument provides a unique format for multiple stages of MS analysis (MS^n).

lead optimization The synthetic modification of a biologically active compound to improve stereoelectronic, physicochemical, pharmacokinetic, and toxicological properties.

limit of detection (LOD) The amount of analyte that yields a signal-to-noise ratio adequate to provide the desired confidence for detection of an analyte. A signal-to-noise (S/N) ratio of 3 is typical.

- limit of quantitation (LOQ)** The amount of analyte that yields a signal-to-noise ratio adequate to provide the desired confidence for quantitation of an analyte. A signal-to-noise (S/N) ratio of 10 is typical.
- lower limit of quantitation (LLOQ)** The lower limit of the linear quantitation range.
- lipophilicity** The affinity of a molecule for a lipophilic environment.
- Manufacturing** The stage of drug development responsible for the manufacture of marketed drug products.
- marketing authorization application (MAA)** The equivalent to the new drug application (NDA) filed in Europe.
- mass chromatogram** *See* extracted ion current profile.
- matrix-assisted laser desorption/ionization (MALDI)** The production of ions from an analyte in the solid state by irradiation with a laser, and the facilitation of a coprecipitated compound that readily absorbs the laser light.
- medicinal chemistry** The design and synthesis of drug candidates.
- metabolism** The physical and chemical processes involved in the maintenance and reproduction of life in which nutrients are broken down to generate energy and to give simpler molecules (catabolism), which by themselves may be used to form more complex molecules (anabolism).
- metabolite** Any intermediate or product that results from metabolism.
- molecular biology** The study of genetic materials and their expression at the molecular level.
- neutral loss MS/MS scan** The operation of a tandem mass spectrometer in which the two mass analyzers are scanned at the same rate, with the second mass analyzer offset (lower) from the first by a constant m/z ratio.
- new chemical entity (NCE)** A compound not previously available for therapeutic use in humans.
- new drug application (NDA)** The registration document filed to rigorously document a new chemical entity's (NCE) properties, manufacturing, safety, and detailed evaluation in human clinical studies.

nuclear magnetic resonance (NMR) A technique for detailed structural analysis that involves observation of the absorption of discrete radio frequencies by specific atoms in molecules exposed to a magnetic field.

parallel analysis Simultaneous processing of more than one sample or compound during one or more steps of an analytical protocol.

pattern recognition The identification of patterns in large data sets, using appropriate mathematical methodologies.

perfusive chromatography HPLC with stationary media that have pores through the particles of the media, resulting in reduced back pressure.

pharmacokinetics Refers to the study of absorption, distribution, metabolism, and excretion (ADME) of bioactive compounds in higher organism.

pharmacophore The ensemble of steric and electronic features necessary to ensure the optimal supramolecular interactions with a specific biological target structure and to trigger (or to block) its biological response.

placebo An inert dosage form identical in appearance, flavor, and odor to the drug product dosage form, but contains no drug.

potency The amount of drug substance in a specific lot of drug product.

preclinical development The stage of drug development responsible for evaluating lead compounds and filing the investigational new drug (IND).

precursor ion scan The operation of a tandem mass spectrometer in which the first mass analyzer is scanned while the second is held at a specific m/z ratio.

process chemistry Development of reagents and conditions for the synthesis of bulk drug substance.

prodrug Any compound that undergoes biotransformation before exhibiting its pharmacological effects.

product ion scan The operation of a tandem mass spectrometer in which the first mass analyzer is held at a specific m/z ratio, while the second is scanned. Also, the operation of an ion trap mass spectrometer in which ions of a specific m/z ratio are isolated and collisionally activated, followed by scanning the product ions.

proteomics Determination of the proteins expressed under specific biological states (e.g., disease) so as to determine their role.

quadrupole time-of-flight mass spectrometer Ions formed in the source region are introduced into a quadrupole mass filter that separates ions based on mass-to-charge ratio (m/z). Selected ions are then transferred into the time-of-flight mass spectrometer (*see* time-of-flight mass spectrometer) for detailed analysis (i.e., high resolution capabilities).

receptor A molecule or a polymeric structure in or on a cell that specifically recognizes and binds a compound that acts as a molecular messenger.

selected ion monitoring (SIM) A mass spectrometry-based screening approach for quantitative analysis where a single m/z value, which corresponds to the drug molecule, is detected.

selected reaction monitoring (SRM) A mass spectrometry-based screening approach for quantitative analysis where two dimensions of mass analysis are employed to detect a unique product ion corresponding to the drug molecule.

sensitivity Refers to a detectable signal for analysis. Defined by the slope of the calibration curve [$d(\text{signal})/d(\text{amount})$].

serial analysis Separate and sequential processing of samples or compounds during one or more steps of an analytical protocol.

single quadrupole mass spectrometer A quadrupole mass filter consists of four cylindrical or hyperbolic shaped rods. A unique combination of direct current (dc) potential and radiofrequency (rf) potential is applied to each pair of rods (one pair 180° out of phase with the other). A mass spectrum results by varying the voltages at a constant rf/dc ratio.

soft spots Refers to the labile substructures of a molecule that indicate chemical and/or metabolic instability.

Solid Phase Extraction (SPE) Use of solid chromatographic media to extract compounds from a liquid sample.

standard operating procedure A document stipulating a specific protocol for analytical or organizational activities for the purpose of satisfying regulatory or organizational guidelines.

structure-Activity relationship (SAR) The relationships between chemical structure and pharmacological activity for a series of compounds.

substructure connectivity The use of MS/MS or MS^n to delineate substructural relationships. Analogous to two-dimensional nuclear magnetic resonance (NMR) techniques.

tandem quadrupole mass spectrometer A tandem quadrupole MS/MS instrument consists of two quadrupole MS filters, MS1 and MS2, separated by a collision cell. Each quadrupole MS filter consists of four cylindrical or hyperbolic-shaped rods. A unique combination of direct current (dc) potential and radiofrequency (rf) potential is applied to each pair of rods (one pair 180° out of phase with the other). A mass spectrum results by varying the voltages at a constant rf/dc ratio. A variety of scan modes (e.g., full scan, product ion, precursor ion, neutral loss) provide unique capabilities for quantitative and qualitative structure analysis.

thermospray ionization (TSI) The liberation of ions from heated droplets occurring in a vacuum region.

thin layer chromatography A technology in which compounds are partitioned between stationary media on a solid support (e.g., glass) and a liquid phase at atmospheric pressure.

time-of-flight mass spectrometer Ions generated either by matrix-assisted laser desorption/ionization (MALDI) or electrospray ionization (ESI) are forced into the flight tube by application of the acceleration voltage from extraction grids. All ions leave the source with the same kinetic energy and travel down the flight tube toward an ion reflector. Separation is based on mass with lighter ions traveling faster than heavier ions. The ion reflector is used to correct for small kinetic energy differences between ions of the same mass resulting in improved resolution and mass accuracy.

total ion current (TIC) chromatogram The mass spectrometry signal that corresponds to the sum of all ions detected in a scan plotted against time.

triple quadrupole mass spectrometer *See* tandem quadrupole mass spectrometer.

xenobiotic A compound foreign to an organism.

REFERENCES

- Ackermann, B. L.; Regg, B. T.; Colombo, L.; Stella, S.; Coutant, J. E. 1996a. "Rapid analysis of antibiotic-containing mixtures from fermentation broths by using liquid chromatography-electrospray ionization-mass spectrometry and matrix-assisted laser desorption ionization-time-of-flight-mass spectrometry." *J. Am. Soc. Mass Spectrom.*, *7*, 1227–1237.
- Ackermann, B. L.; Gillespie, T. A.; Regg, B. T.; Austin, K. F.; Coutant, J. E. 1996b. "Application of packed capillary liquid chromatography/mass spectrometry with electrospray ionization to the study of the human bio-transformation of the anti-emetic drug dolasetron." *J. Mass Spectrom.*, *31*, 681–689.
- Ackermann, B. L.; Ruterbories, K. J.; Hanssen, B. R.; Lindstrom, T. D. 1998. "Increasing the throughput of microsomal stability screening using fast gradient elution LC/MS." *Proc. 46th ASMS Conf. Mass Spectrom. and Allied Topics* (Orlando, Florida), 16.
- Aebersold, R.; Bures, E. J.; Namchuk, M.; Goghari, M. H.; Shushan, B.; Covey, T. C. 1992. "Design, synthesis, and characterization of a protein sequencing reagent yielding amino acid derivatives with enhanced detectability by mass spectrometry." *Protein Sci.*, *1*, 494–503.
- Afeyan, N. B.; Fulton, S. P.; Regnier, F. E. 1991. "Perfusion chromatography packing materials for proteins and peptides." *J. Chromatogr.*, *544*, 267–279.
- Allanson, J. P.; Biddlecombe, R. A.; Jones, A. E.; Pleasance, S. 1996. "The use of automated solid phase extraction in the '96 well' format for high throughput bioanalysis using liquid chromatography coupled to tandem mass spectrometry." *Rapid Commun. Mass Spectrom.*, *10*, 811–816.

- Allen, M. C.; Shah, T. S.; Day, W. W. 1998. "Rapid determination of oral pharmacokinetics and plasma free fraction using cocktail approaches: methods and application." *Pharm. Res.*, *15*, 93–97.
- Anderegg, R. J.; Wagner, D. S.; Blackbrun, R. K.; Opiteck, G. J.; Jorgenson, J. W. 1997 "A multidimensional approach to protein characterization." *J. Protein Chem.*, *16*, 523–526.
- Andren, P. E.; Emmett, M. R.; Caprioli, R. M. 1995. "Micro-electrospray: zeptomole/attomole per microliter sensitivity for peptides." *J. Am. Soc. Mass Spectrom.*, *5*, 867–869.
- Apffel, A.; Chakel, J.; Udiavar, S.; Hancock, W. S.; Souders, C.; Pungor, E. Jr. 1995. "Application of capillary electrophoresis, high-performance liquid chromatography, on-line electrospray mass spectrometry and matrix-assisted laser desorption ionization—time of flight mass spectrometry to the characterization of single-chain plasminogen activator." *J. Chromatogr. A*, *717*, 41–60.
- Apffel, A.; Chakel, J. A.; Hancock, W. S.; Souders, C.; M'Timkulu, T.; Pungor, E. Jr. 1996. "Application of multidimensional affinity high-performance liquid chromatography and electrospray ionization liquid chromatography-mass spectrometry to the characterization of glycosylation in single-chain plasminogen activator. Initial results." *J. Chromatogr. A*, *750*, 35–42.
- Arnott, D. P.; Henzel, W. J.; Stults, J. T. 1995. "Identification of proteins from two-dimensional electrophoresis gels by peptide mass fingerprinting." In *Biochemical and Biotechnological Applications of Electrospray Ionization Mass Spectrometry*, Snyder, A. P., ed., Washington, D.C.: American Chemical Society, *619*, 226–243.
- Arnott, D.; O'Connell, K. L.; King, K. L.; Stults, J. T. 1998. "An integrated approach to proteome analysis: identification of proteins associated with cardiac hypertrophy." *Anal. Biochem.*, *258*, 1–18.
- Arpino, P. J. 1982. "On-line liquid chromatography/mass spectrometry? An odd couple!" *Trends Anal. Chem.*, *1*, 154–158.
- Arpino, P. J.; Dawkins, B. G.; McClafferty, F. W. 1974. "A liquid chromatography/mass spectrometry system providing continuous monitoring with nanogram sensitivity." *J. Chromatogr. Sci.*, *12*, 574–578.
- Arpino, P. J.; Guiochon, G.; Krien, P.; Devant, G. 1979. "Optimization of the instrumental parameters of a combined liquid chromatograph-mass spectrometer, coupled by an interface for direct liquid introduction." *J. Chromatogr.*, *185*, 529–547.
- Ayrton, J.; Dear, G. J.; Leavens, W. J.; Mallett, D. N.; Plumb, R. S. 1997. "The use of turbulent flow chromatography/mass spectrometry for the rapid, direct analysis of a novel pharmaceutical compound in plasma." *Rapid Commun. Mass Spectrom.*, *11*, 1953–1958.

- Ayrton, J.; Plumb, R.; Leavens, W. J.; Mallett, D.; Dickins, M.; Dear, G. J. 1998a. "Application of a generic fast gradient liquid chromatography tandem mass spectrometry method for the analysis of cytochrome p450 probe substrates." *Rapid Commun. Mass Spectrom.*, 12, 217–224.
- Ayrton, J.; Dear, G. J.; Leavens, W. J.; Mallett, D. N.; Plumb, R. S. 1998b. "Use of generic fast gradient liquid chromatography-tandem mass spectroscopy in quantitative bioanalysis." *J. Chromatogr. B Biomed. Sci. Appl.*, 709, 243–254.
- Babiak, J. 1997. "Transforming your robotics into an infrastructure for the future." *J. Biomol. Screening*, 2, 139–143.
- Baillie, T. A. 1992. "Advances in the application of mass spectrometry to studies of drug metabolism, pharmacokinetics and toxicology." *Int. J. Mass Spectrom. Ion Proc.*, 118/119, 289–314.
- Banerjee, P. K.; Rosofsky, M. 1997. "Drug discovery: the quest for innovation and productivity." *Scrip Magazine*, November, 35–38.
- Banks, J. F.; Gulcicek, E. E. 1997. "Rapid peptide mapping by reversed-phase chromatography on nonporous silica with on-line electrospray time-of-flight mass spectrometry." *Anal. Chem.*, 69, 3973–3978.
- Bansal, S.; Liang, Z. 1998. "Rapid, uniform and rational bioanalytical methods development using LC/MS/MS." *Proc. 46th ASMS Conf. Mass Spectrom. and Allied Topics* (Orlando, Florida), 716.
- Barbuch, R. J.; Coutant, J. E.; Welsh, M. B.; Setchell, K. D. 1989. "The use of thermospray liquid chromatography/tandem mass spectrometry for the class identification and structural verification of phytoestrogens in soy protein preparations." *Biomed. Environ. Mass Spectrom.*, 18, 973–977.
- Bates, J. H. 1995. "Tuberculosis chemotherapy. The need for new antituberculosis drugs is urgent." *Am. J. Respir. Crit. Care Med.*, 151, 942–943.
- Baxter, A. D. 1997. "Meeting client needs in combinatorial chemistry: a service company perspective." *Drug Discovery Today*, 2, 307–308.
- Beattie, I. G.; Blake, T. J. 1989. "The structural identification of drug metabolites using thermospray liquid chromatography/mass spectrometry." *Biomed. Environ. Mass Spectrom.*, 18, 872–877.
- Beaudry, F.; Yves Le Blanc, J. C.; Coutu, M.; Brown, N. K. 1998. "In vivo pharmacokinetic screening in cassette dosing experiments: the use of on-line prospekt® liquid chromatography/atmospheric pressure chemical ionization tandem mass spectrometry technology in drug discovery." *Rapid Commun. Mass Spectrom.*, 12, 1216–1222.
- Berman J.; Halm, K.; Adkison, K.; Shaffer, J. 1997. "Simultaneous pharmacokinetic screening of a mixture of compounds in the dog using API LC/MS/MS analysis for increased throughput." *J. Med. Chem.*, 40, 827–829.

- Blackburn, R. K.; Moseley, M. A. III 1999. "Quadrupole time-of-flight mass spectrometry: a powerful new tool for protein identification and characterization." *Am. Pharm. Rev.*, 2, 49–59.
- Blackstock, W. 2000. "Trends in automation and mass spectrometry for proteomics." In *Proteomics: A Trends Guide*, Blackstock, W. P.; Mann, M., eds., Elsevier, New York, NY, 12–17.
- Blakely, C. R.; Vestal, M. L. 1983. "Thermospray interface for liquid chromatography/mass spectrometry." *Anal. Chem.*, 55, 750–754.
- Blakely, C. R.; Carmody, J. J.; Vestal, M. L. 1980. "Liquid chromatograph-mass spectrometer for analysis of non-volatile samples." *Anal. Chem.*, 52, 1636–1640.
- Blom, K. F.; Combs, A. P.; Rockwell, A. L.; Oldenburg, K. R.; Zhang, J. H.; Chen, T. 1998 "Direct mass spectrometric determination of bead bound compounds in a combinatorial lead discovery application." *Rapid Commun. Mass Spectrom.*, 12, 1192–1198.
- Bowers, G. D.; Higton, D. M.; Manchee, G. R.; Oxford, J.; Saynor, D. A. 1991. "Thermospray liquid chromatography-mass spectrometry for the characterisation of sulphate ester conjugates." *J. Chromatogr.*, 554, 175–180.
- Brenner, S.; Lerner, R. A. 1992. "Encoded combinatorial chemistry." *Proc. Nat. Acad. Sci. USA*, 89, 5181–5183.
- Brewer, E.; Henion, J. D. 1998. "Atmospheric pressure ionization LC/MS/MS techniques for drug disposition studies." *J. Pharm. Sci.*, 87, 395–402.
- Brownsill, R.; Combal, J.-P.; Taylor, A.; Bertrand, M.; Luijten, W.; Walther, B. 1994. "The application of electrospray and neutral-loss mass spectrometry to the identification of the metabolites of S12813 in rat liver slices." *Rapid Commun. Mass Spectrom.*, 8, 361–365.
- Bruins, A. P. 1991. "Liquid chromatography-mass spectrometry with ion-spray and electrospray interfaces in pharmaceutical and biomedical research." *J. Chromatogr.*, 554, 39–46.
- Bruins, A. P. 1994. "Atmospheric-pressure-ionization mass spectrometry." *Trends in Anal. Chem.*, 13, 37–43.
- Bruins, A. P. 1998. "Mechanistic aspects of electrospray ionization." *J. Chromatogr. A*, 794, 345–357.
- Bruins, A. P.; Covey, T. R.; Henion, J. D. 1987. "Ion spray interface for combined liquid chromatography/atmospheric pressure ionization mass spectrometry." *Anal. Chem.*, 59, 2642–2646.
- Bryant, M. S.; Korfmacher, W. A.; Wang, S.; Nardo, C.; Nomeir, A. A.; Lin, C. C. 1997. "Pharmacokinetic screening for the selection of new drug discovery candidates is greatly enhanced through the use of liquid chromatography-atmospheric pressure ionization tandem mass spectrometry." *J. Chromatogr. A*, 777, 61–66.

- Bu, H.-Z.; Poglod, M.; Micetich, R. G.; Khan, J. K. 2000. "High throughput caco-2 cell permeability screening by cassette dosing and sample pooling approaches using direct injection/on-line guard cartridge extraction/tandem mass spectrometry." *Rapid Commun. Mass Spectrom.*, *14*, 523–528.
- Bu, H.-Z.; Magis, L.; Knuth, K.; Teitelbaum, P. 2001. "High-throughput cytochrome P450 (CYP) inhibition screening via a cassette probe-dosing strategy. VI. Simultaneous evaluation of inhibition potential of drugs on human hepatic isozymes CYP2A6, 3A4, 2C9, 2D6 and 2E1." *Rapid Commun. Mass Spectrom.*, *15*, 741–748.
- Buhrman, D. L.; Price, P. I.; Rudewicz, P. J. 1996. "Quantitation of SR 27417 in human plasma using electrospray liquid chromatography-tandem mass spectrometry: a study of ion suppression." *J. Am. Soc. Mass Spectrom.*, *7*, 1099–1105.
- Burdick, D. J.; Stults, J. T. 1997. "Analysis of peptide synthesis products by electrospray ionization mass spectrometry." *Methods Enzymol.*, *289*, 499–519.
- Burlingame, A. L.; Carr, S. A., eds. 1996. *Mass Spectrometry in the Biological Sciences*, Totowa, NJ: Humana Press.
- Burlingame, A. L.; Boyd, R. K.; Gaskell, S. J. 1998. "Mass spectrometry." *Anal. Chem.*, *70*, 647R–716R.
- Cai, J.; Henion, J. 1997. "Quantitative Multi-residue determination of beta-agonists in bovine urine using on-line immunoaffinity extraction-coupled column packed capillary liquid chromatography-tandem mass spectrometry." *J. Chromatogr. B Biomed. Sci. Appl.*, *11*, 357–370.
- Caldwell, G. W.; Easlick, S. M.; Gunnet, J.; Masucci, J. A.; Demarest, K. 1998. "In vitro permeability of eight beta-blockers through caco-2 monolayers utilizing liquid chromatography/electrospray ionization mass spectrometry." *J. Mass Spectrom.*, *33*, 607–614.
- Carr, S. A.; Huddleston, M. J.; Bean, M. F. 1993. "Selective identification and differentiation of N- and O-linked oligosaccharides in glycoproteins by liquid chromatography-mass spectrometry." *Protein Science*, *2*, 183–196.
- Carroll, D. I.; Dzidic, I.; Stillwell, R. N.; Haegele, K. D.; Horning, E. C. 1975. "Atmospheric pressure ionization mass spectrometry: corona discharge ion source for use in liquid chromatograph-mass spectrometer-computer analytical system." *Anal. Chem.*, *47*, 2369–2373.
- Celis, J. E.; Rasmussen, H. H.; Leffers, H.; Madsen, P.; Honore, B.; Gesser, B.; Dejgaard, K.; Vandekerckhove, J. 1991. "Human cellular protein patterns and their link to genome DNA sequence data: usefulness of two-dimensional gel electrophoresis and microsequencing." *FASEB J.*, *5*, 2200–2208.

- Cepa, S.; Searle, P. 1998. "Establishing an open access LC/MS lab for pharmaceutical discovery and development." *Proc. 46th ASMS Conf. Mass Spectrom. and Allied Topics* (Orlando, Florida), 283.
- Chakel, J. A.; Pungor, E. Jr.; Hancock, W. S.; Swedberg, S. A. 1997. "Analysis of recombinant DNA-derived glycoproteins via high-performance capillary electrophoresis coupled with off-line matrix-assisted laser desorption ionization time-of-flight mass spectrometry." *J. Chromatogr. B Biomed. Sci. Appl.*, 689, 215–220.
- Chang, J. P.; Kiehl, D. E.; Kennington, A. 1997. "Separation and characterization of the tryptic peptide mapping of recombinant bovine growth hormone by reversed-phase high-performance liquid chromatography electrospray mass spectrometry." *Rapid Commun. Mass Spectrom.*, 11, 1266–1270.
- Chen, T. M.; Chan, K. Y.; Coutant, J. E.; Okerholm, R. A. 1991. "Determination of the metabolites of terfenadine in human urine by thermospray liquid chromatography-mass spectrometry." *J. Pharm. Biomed. Anal.*, 9, 929–933.
- Chong, B. E.; Hamler, R. L.; Lubman, D. M.; Ethier, S. P.; Rosenspire, A. J.; Miller, F. R. 2001. "Differential screening and mass mapping of profiles from premalignant and cancer cell lines using nonporous reversed phase HPLC with on-line detection by ESI-TOFMS." *Anal. Chem.*, 73, 1219–1227.
- Clauser, K. R.; Baker, P.; Burlingame, A. L. 1999. "Role of accurate mass measurement (± 10 ppm) in protein identification strategies employing MS or MS/MS and database searching." *Anal. Chem.*, 71, 2871–2882.
- Cogburn, J. N.; Donovan, M. G.; Schasteen, C. S. 1991. "A model of human small intestinal absorptive cells. 1. Transport barrier." *Pharm. Res.*, 8, 210–216.
- Cole, M. J.; Cunniff, J.; Drexler, D.; Hemenway, E.; Land, A. 1998. "Large scale quantitative analysis of pharmaceuticals via LC-MS and LC-MS/MS ion trap mass spectrometry." *Proc. 46th ASMS Conf. Mass Spectrom. and Allied Topics* (Orlando, Florida), 12.
- Cooks, R. G.; Busch, K. L. 1982. "Counting molecules by desorption ionization and mass spectrometry/mass spectrometry." *J. Chem. Educ.*, 59, 926–933.
- Covey, T. R.; Lee, E. D.; Henion, J. D. 1986. "High-speed liquid chromatography/tandem mass spectrometry for the determination of drugs in biological samples." *Anal. Chem.*, 58, 2453–2460.
- Covey, T. R.; Huang, E. C.; Henion, J. D. 1991. "Structural characterization of protein tryptic peptides via liquid chromatography/mass spectrometry and collision-induced dissociation of their doubly charged molecular ions." *Anal. Chem.*, 63, 1193–1200.

- Covey, T. 1995. "Analytical characteristics of the electrospray ionization process." In *Biochemical and Biotechnological Applications of Electrospray Ionization Mass Spectrometry*, Snyder, A. P., ed., Washington, D.C.: American Chemical Society, 619, 21–59.
- Cox, K. A.; Dunn-Meynell, K.; Korfmacher, W. A.; Broske, L.; Nomeir, A. A.; Lin, C. C.; Cayen, M. N.; Barr, W. H. 1999. "Novel procedure for rapid pharmacokinetic screening of discovery compounds in rats." *Drug Discov. Today*, 4, 232–237.
- Davies, J. 1994. "Inactivation of antibiotics and the dissemination of resistance genes." *Science*, 264, 375–382.
- Davis, M. T.; Lee, T. D. 1998. "Rapid protein identification using a microscale electrospray LC/MS system on an ion trap mass spectrometer." *J. Am. Soc. Mass Spectrom.*, 9, 194–201.
- Davis, M. T.; Stahl, D. C.; Hefta, S. A.; Lee, T. D. 1995. "A microscale electrospray interface for on-line, capillary liquid chromatography/tandem mass spectrometry of complex peptide mixtures." *Anal. Chem.*, 67, 4549–4556.
- Davis, R. G.; Anderegg, R. J.; Blanchard, S. G. 1999. "Iterative size-exclusion chromatography coupled with liquid chromatographic mass spectrometry to enrich and identify tight-binding ligands from complex mixtures." *Tetrahedron*, 55, 1653–1667.
- Dear, G. J.; Fraser, T. J.; Patel, D. K.; Long, J.; Pleasance, S. 1998. "Use of liquid chromatography-tandem mass spectrometry for the quantitative and qualitative analysis of an antipsychotic agent and its metabolites in human plasma and urine." *J. Chromatogr. A*, 794, 27–36.
- de Biasi, V.; Haskins, N.; Organ, A.; Bateman, R.; Giles, K.; Jarvis, S. 1999. "High throughput liquid chromatography/mass spectrometric analyses using a novel multiplexed electrospray interface." *Rapid Commun. Mass Spectrom.*, 13, 1165–1168.
- Desai, M. C.; Zuckermann, R. N.; Moos, W. H. 1994. "Recent advances in the generation of chemical diversity libraries." *Drug Dev. Res.*, 33, 174–188.
- Devlin, J. J.; Lian, A.; Trinh, L.; Plolkoff, M. A.; Senator, D.; Sheng, W.; Kondracki, J.; Kretschmer, P. J.; Morser, J.; Lipson, S. E.; Spann, R.; Loughlin, J. A.; Dunn, K. V.; Morrissey, M. M. 1996. "High capacity screening of pooled compounds: identification of active compound without re-assay of pool members." *Drug Dev. Res.*, 37, 80–85.
- Ding, J.; Burkhardt, W.; Kassel, D. B. 1994. "Identification of phosphorylated peptides from complex mixtures using negative-ion orifice-potential stepping and capillary liquid chromatography/electrospray ionization mass spectrometry." *Rapid Commun. Mass Spectrom.*, 8, 94–98.

- Dower, W. J.; Fodor, S. P. A. 1991. "The search for molecular diversity (II): recombinant and synthetic randomized peptide libraries." *Annu. Rep. Med. Chem.*, 26, 271–280.
- Drews, J.; Ryser, S. 1997. "Pharmaceutical innovation between scientific opportunities and economic constraints." *Drug Discovery Today*, 2, 365–372.
- Ducret, A.; Van Oostveen, I.; Eng, J. K.; Yates, J. R. III; Aebersold, R. 1998. "High throughput protein characterization by automated reverse-phase chromatography/electrospray tandem mass spectrometry." *Protein Sci.*, 7, 706–719.
- Duffus, J. H. 1993. "Glossary for chemists of terms used in toxicology." *Pure Appl. Chem.*, 65, 2003–2122.
- Duléry, B. D.; Verne-Mismer, J.; Wolf, E.; Kugel, C.; Van Hijfte, L. 1999. "Analyses of compound libraries obtained by high-throughput parallel synthesis: strategy of quality control by high-performance liquid chromatography, mass spectrometry and nuclear magnetic resonance techniques." *J. Chromatogr. B Biomed. Sci. Appl.*, 725, 39–47.
- Dunayevskiy, Y.; Vouros, P.; Carell, T.; Wintner, E. A.; Rebek, J. Jr. 1995. "Characterization of the complexity of small-molecule libraries of electrospray ionization mass spectrometry." *Anal. Chem.*, 67, 2906–2915.
- Eckers, C.; Haskins, N.; Langridge, J. 1997. "The use of liquid chromatography combined with a quadrupole time-of-flight analyser for the identification of trace impurities in drug substance." *Rapid Commun. Mass Spectrom.*, 11, 1916–1922.
- Ehlhardt, W. J.; Woodland, J. M.; Baughman, T. M.; Vandenbranden, M.; Wrighton, S. A.; Kroin, J. S.; Norman, B. H.; Maple, S. R. 1998. "Liquid chromatography/nuclear magnetic resonance spectroscopy and liquid chromatography/mass spectrometry identification of novel metabolites of the multidrug resistance modulator LY335979 in rat bile and human liver microsomal incubations." *Drug Metab. Dispos.*, 26, 42–51.
- Emmett, M. R.; Caprioli, R. M. 1994. "Micro-electrospray mass spectrometry: ultra-high-sensitivity analysis of peptides and proteins." *J. Am. Soc. Mass Spectrom.*, 5, 605–613.
- Eng, J. K.; McCormack, A. L.; Yates, J. R. 1994. "An approach to correlate tandem mass spectral data of peptides with amino acid sequences in a protein database." *J. Am. Soc. Mass Spectrom.*, 5, 976–989.
- Enjalbal, C.; Martinez, J.; Aubagnac, J. L. 2000. "Mass spectrometry in combinatorial chemistry." *Mass Spectrom. Rev.*, 19, 139–161.
- Evans, E. H.; Wolff, J.-C.; Eckers, C. 2001. "Sulfur-specific detection of impurities in cimetidine drug substance using liquid chromatography coupled to high resolution inductively coupled plasma mass spectrometry and electrospray mass spectrometry." *Anal. Chem.*, 73, 4722–4728.

- Fang, A. S.; Vouros, P.; Stacey, C. C.; Kruppa, G. H.; Laukien, F. H.; Wintner, E. A.; Carell, T.; Rebek, J. Jr. 1998. "Rapid characterization of combinatorial libraries using electrospray ionization Fourier transform ion cyclotron resonance mass spectrometry." *Comb. Chem. High Throughput Screen*, 1, 23–33.
- Fang, L.; Pan, J.; Yan, B. 2001. "High-throughput determination of identity, purity, and quantity of combinatorial library members using LC/UV/ELSD/MS." *Biotechnol. Bioeng.*, 71, 162–171.
- Feng, B.; McQueney, M. S.; Mezzasalma, T. M.; Slemmon, J. R. 2001. "An integrated ten-pump, eight-channel parallel LC/MS system for automated high-throughput analysis of proteins." *Anal. Chem.*, 73, 5691–5697.
- Fenn, J. B.; Mann, M.; Meng, C. K.; Wong, S. F.; Whitehouse, C. M. 1989. "Electrospray ionization for mass spectrometry of large biomolecules." *Science*, 246, 64–71.
- Fernandez-Metzler, C. L.; Owens, K. G.; Baillie, T. A.; King, R. C. 1999. "Rapid liquid chromatography with tandem mass spectrometry-based screening procedures for studies on the biotransformation of drug candidates." *Drug Metab. Dispos.*, 27, 32–40.
- Figeys, D.; Aebersold, R. 1997. "High sensitivity identification of proteins by electrospray ionization tandem mass spectrometry: initial comparison between an ion trap mass spectrometer and a triple quadrupole mass spectrometer." *Electrophoresis*, 18, 360–368.
- Figeys, D.; Aebersold, R. 1998. "High sensitivity analysis of proteins and peptides by capillary electrophoresis-tandem mass spectrometry: recent developments in technology and applications." *Electrophoresis*, 19, 885–892.
- Figeys, D.; Ducret, A.; Yates, J. R. III; Aebersold, R. 1996. "Protein identification by solid phase microextraction-capillary zone electrophoresis-microelectrospray-tandem mass spectrometry." *Nat. Biotechnol.*, 14, 1579–1583.
- Fink, S. W.; Rourick, R. A.; Whitney, J. L.; Volk, K. J.; Klohr, S. E.; DiDonato, G. C.; Kerns, E. H.; Lee, M. S. 1997. "Accelerating drug development using automated predictive stability profiling methodologies." *Annual Meeting of the American Association of Pharmaceutical Scientists* (Boston, Massachusetts), 590.
- Fitch, W. L. 1998–99. "Analytical methods for quality control of combinatorial libraries." *Mol. Divers.*, 4, 39–45.
- Foltz, R. L. 1978. "Quantitative analysis of abused drugs in physiological fluids by gas chromatography/chemical ionization mass spectrometry." In *Quantitative Mass Spectrometry in Life Sciences II*, De Leenheer, A. P.; Roncucci, R. R.; Van Peteghem, C., eds., Amsterdam: Elsevier, 39–62.

- Fouda, H.; Nocerini, M.; Schneider, R.; Gedutis, C. 1991. "Quantitative analysis by high-performance liquid chromatography atmospheric pressure chemical ionization mass spectrometry: the determination of the renin inhibitor CP-80,794 in human serum." *J. Am. Soc. Mass Spectrom.*, *2*, 164–167.
- Frye, R. F.; Matzke, G. R.; Adedoyin, A.; Porter, J. A.; Branch, R. A. 1997. "Validation of the five-drug 'Pittsburgh cocktail' approach for assessment of selective regulation of drug-metabolizing enzymes." *Clin. Pharmacol. Ther.*, *62*, 365–376.
- Gallop, M. A.; Barrett, R. W.; Dower, W. J.; Fodor, S. P. A.; Gordon, E. M. 1994. "Applications of combinatorial technologies to drug discovery. 1. Background and peptide combinatorial libraries." *J. Med. Chem.*, *37*, 1233–1251.
- Games, D. E.; McDowell, M. A.; Levsen, K.; Schafer, K. H.; Dobberstein, P.; Gower, J. L. 1984. "A comparison of moving belt interfaces for liquid chromatography mass spectrometry." *Biomed. Mass Spectrom.*, *11*, 87–95.
- Ganem, B.; Li, Y.; Henion, J. D. 1991. "Detection of non covalent receptor-ligand complexes by mass spectrometry." *J. Am. Chem. Soc.*, *113*, 6294–6296.
- Ganguly, A. K.; Praminik, B. N.; Tsarbopoulos, A.; Covey, T. R.; Huang, E.; Fuhrman, S. A. 1992. "Mass spectrometric detection of the non covalent GDP-bound conformational state of the human H-ras protein." *J. Am. Chem. Soc.*, *114*, 6559–6560.
- Garland, W. A.; Powell, M. L. 1981. "Quantitative selected ion monitoring (QSIM) of drugs and/or drug metabolites in biological matrices." *J. Chromatogr. Sci.*, *19*, 392–434.
- Gatlin, C. L.; Kleemann, G. R.; Hays, L. G.; Link, A. J.; Yates, J. R. 1998. "Protein identification at the low femtomole level from silver-stained gels using a fritless electrospray interface for liquid chromatography-microspray and nanospray mass spectrometry." *Anal. Biochem.*, *263*, 93–101.
- Georgopapadakou, N. H.; Walsh, T. J. 1994. "Human mycoses: drugs and targets for emerging pathogens." *Science*, *264*, 371–373.
- Geysen, H. M.; Wagner, C. D.; Bodnar, W. M.; Markworth, C. J.; Parke, G. J.; Schoenen, F. J.; Wagner, D. S.; Kinder, D. S. 1996. "Isotope or mass encoding of combinatorial libraries." *Chem. Biol.*, *3*, 679–688.
- Gilbert, J. R.; Lewer, P. 1998. "LC/MSⁿ as a tool for the identification of biologically active compounds from natural product mixtures." *Proc. 46th ASMS Conf. Mass Spectrom. and Allied Topics* (Orlando, Florida), 21.
- Gillespie, T.; Barbuch, R.; Berna, M.; Bowsher, R.; Jensen, C. 1998. "LC/MS/MS identification and profiling of pergolide mesylate metabo-

- lites in human, rat, and dog liver slices." *Proc. 46th ASMS Conf. Mass Spectrom. and Allied Topics* (Orlando, Florida), 706.
- Gilpin, R. K.; Pachla, L. A. 2001. "Pharmaceuticals and related drugs." *Anal. Chem.*, 73, 2805–2816.
- Gordon, E. M.; Barrett, R. W.; Dower, W. J.; Fodor, S. P. A.; Gallop, M. A. 1994. "Applications of combinatorial technologies to drug discovery. 2. Combinatorial organic synthesis, library screening strategies, and future directions." *J. Med. Chem.*, 37, 1385–1401.
- Griffin, T. J.; Gygi, S. P.; Rist, B.; Aebersold, R. 2001. "Quantitative proteomic analysis using a MALDI quadrupole time-of-flight mass spectrometer." *Anal. Chem.*, 73, 978–986.
- Gygi, S. P.; Rist, B.; Gerber, S. A.; Turecek, F.; Gelb, M. H.; Aebersold, R. 1999. "Quantitative analysis of complex protein mixtures using isotope-coded affinity tags." *Nat. Biotechnol.*, 17, 994–999.
- Hancock, W. S.; Apffel, A.; Chakel, J.; Souders, C.; M'Timkulu, T.; Pungor, E.; Guzzetta, A. W. 1996. "Reversed-phase peptide mapping of glycoproteins using liquid chromatography/electrospray ionization-mass spectrometry." *Methods Enzymol.*, 271, 403–427.
- Hanisch, F. G.; Green, B. N.; Bateman, R.; Peter-Katalinic, J. 1998. "Localization of O-glycosylation sites of MUC1 tandem repeats by QTOF ESI mass spectrometry." *J. Mass Spectrom.*, 33, 358–362.
- Hayes, M. J.; Lankmayer, E. P.; Vouros, P.; Karger, B. L.; McGuire, J. M. 1983. "Moving belt interface with spray deposition for liquid chromatography/mass spectrometry." *Anal. Chem.*, 55, 1745–1752.
- Haynes, P. A.; Yates, J. A. III. 2000. "Proteome profiling—pitfalls and progress." *Yeast*, 17, 81–87.
- Heath, T. G.; Giordani, A. B. 1993. "Reversed-phase capillary high-performance liquid chromatography with on-line UV, fluorescence and electrospray ionization mass spectrometric detection in the analysis of peptides and proteins." *J. Chromatogr.*, 638, 9–19.
- Heath, T. G.; Mooney, J. P.; Broersma, R. 1997. "Narrow-bore liquid chromatography-tandem mass spectrometry with simultaneous radioactivity monitoring for partially characterizing the biliary metabolites of an arginine fluoroalkyl ketone analog of D-MePhe-Pro-Arg, a potent thrombin inhibitor." *J. Chromatogr. B Biomed. Sci. Appl.*, 688, 281–289.
- Heller, R.; Hindle, T. 1998. *Essential Manager's Manual*, New York: DK Publishing, 168.
- Henion, J. D.; Covey, T. R. 1986. "The determination of drugs in urine by LC-MS and LC-MS/MS." In *Mass Spectrometry in Biomedical Research*, Gaskel, S. J., ed., New York: John Wiley and Sons, 477–486.
- Henion, J.; Brewer, E.; Rule, G. 1998. "Sample preparation for LC/MS/MS: analyzing biological and environmental samples." *Anal. Chem.*, 70, 650A–656A.

- Henzel, W. J.; Billeci, T. M.; Stults, J. T.; Wong, S. C.; Grimley, C. G.; Wantanabe, C. W. 1993. "Identifying proteins from two-dimensional gels by molecular mass searching of peptide fragments in protein sequence databases." *Proc. Natl. Acad. Sci.*, 90, 5011–5015.
- Herron, W. J.; Eadie, J.; Penman, A. D. 1995. "Estimation of ranolazine and eleven phase I metabolites in human plasma by liquid chromatography-atmospheric pressure chemical ionization mass spectrometry with selected-ion monitoring." *J. Chromatogr. A*, 712, 55–60.
- Higgs, R. E. 1998. "Automatic deconvolution of complex mixture components from HPLC-MS data." *Proc. 46th ASMS Conf. Mass Spectrom. and Allied Topics* (Orlando, Florida), 816.
- Hilgers, A. R.; Conradi, R. A.; Burton, P. S. 1990. "Caco-2 cell monolayers as a model for drug transport across the intestinal mucosa." *Pharm. Res.*, 7, 902–910.
- Hirschman, R. 1991. "Medicinal chemistry in the golden age of biology: lessons from steroid and peptide research." *Angew. Chem.*, 30, 1278–1301.
- Hoke, S. H. II; Tomlinson, J. A.; Bolden, R. D.; Morand, K. L.; Pinkston, J. D.; Wehmeyer, K. R. 2001. "Increasing bioanalytical throughput using pcSFC-MS/MS: 10 minutes per 96-well plate." *Anal. Chem.*, 73, 3083–3088.
- Holt, R. M.; Newman, M. J.; Pullen, F. S.; Richards, D. S.; Swanson, A. G. 1997. "High-performance liquid chromatography/NMR spectrometry/mass spectrometry: further advances in hyphenated technology." *J. Mass Spectrom.*, 32, 64–70.
- Hop, C. E.; Wang, Z.; Chen, Q.; Kwei, G. 1998. "Plasma-pooling methods to increase throughput for in vivo pharmacokinetic screening." *J. Pharm. Sci.*, 87, 901–903.
- Hopfgartner, G.; Bean, K.; Henion, J. Henry, R. 1993. "Ion spray mass spectrometric detection for liquid chromatography: a concentration- or a mass-flow-sensitive device?" *J. Chromatogr.*, 647, 51–61.
- Hopfgartner, G.; Chernushevich, I.; Covey, T.; Bonner, R. 1998. "Exact mass measurements on product ions for structural elucidation of drug metabolites with a tandem quadrupole TOF instrument." *Proc. 46th ASMS Conf. Mass Spectrom. and Allied Topics* (Orlando, Florida), 713.
- Houthaeve, T.; Gausepohl, H.; Mann, M.; Ashman, K. 1995. "Automation of micro-preparation and enzymatic cleavage of gel electrophoretically separated proteins." *FEBS Lett.*, 376, 91–94.
- Houthaeve, T.; Gausepohl, H.; Ashman, K.; Nillson, T.; Mann, M. 1997. "Automated protein preparation techniques using a digest robot." *J. Protein Chem.*, 16, 343–348.
- Hsieh, Y. F.; Gordon, N.; Regnier, F.; Afeyan, N.; Martin, S. A.; Vella, G. J. 1997. "Multidimensional chromatography coupled with mass spectrometry for target-based screening." *Mol. Divers.*, 2, 189–196.

- Hsu, B. H.; Orton, E.; Tang, S. Y.; Carlton, R. A. 1999. "Application of evaporative light scattering detection to the characterization of combinatorial and parallel synthesis libraries for pharmaceutical drug discovery." *J. Chromatogr. B*, 725, 103–112.
- Huang, N.; Siegel, M. M.; Kruppa, G. H.; Laukien, F. H. 1999. "Automation of a fourier transform ion cyclotron resonance mass spectrometer for acquisition, analysis, and e-mailing of high-resolution exact-mass electrospray ionization mass spectral data." *J. Am. Soc. Mass Spectrom.*, 10, 1166–1173.
- Hughes, I. 1998. "Design of self-coded combinatorial libraries to facilitate direct analysis of ligands by mass spectrometry." *J. Med. Chem.*, 41, 3804–3811.
- Hung, D. T.; Jamison, T. F.; Schreiber, S. L. 1996. "Understanding and controlling the cell cycle with natural products." *Chem. Biol.*, 3, 623–639.
- Hunt, D. F.; Henderson, R. A.; Shabanowitz, J.; Sakaguchi, K.; Michel, H.; Sevilir, N.; Cox, A. L.; Appella, E.; Engelhard, V. H. 1992. "Characterization of peptides bound to the class I MHC molecule HLA-A2.1 by mass spectrometry." *Science*, 255, 1261–1263.
- Immler, D.; Gremm, D.; Kirsch, D.; Spengler, B.; Presek, P.; Meyer, H. E. 1998. "Identification of phosphorylated proteins from thrombin-activated human platelets isolated by two-dimensional gel electrophoresis by electrospray ionization-tandem mass spectrometry (ESI-MS/MS) and liquid chromatography-electrospray ionization-mass spectrometry (LC-ESI-MS)." *Electrophoresis*, 19, 1015–1023.
- Irabarne, J. V.; Dziedzic, P. J.; Thomson, B. A. 1983. "Atmospheric pressure ion evaporation-mass spectrometry." *Int. J. Mass Spectrom. Ion Phys.*, 50, 331–347.
- Janiszewski, J.; Schneider, P.; Hoffmaster, K.; Swyden, M.; Wells, D.; Fouda, H. 1997. "Automated sample preparation using membrane microliter extraction for bioanalytical mass spectrometry." *Rapid Commun. Mass Spectrom.*, 11, 1033–1037.
- Janota, K.; Carter, G. T. 1998. "Natural products library screening using LC/MS and LC/MS/MS." *Proc. 46th ASMS Conf. Mass Spectrom. and Allied Topics* (Orlando, Florida), 557.
- Jensen, O. N. 1999. "Sample preparation methods for mass spectrometric peptide mapping directly from 2-DE gels." In *2-D Proteome Analysis Protocols*, Link, A. J., ed., Humana Press (Totowa, New Jersey), 513–530.
- Johnson, J. V.; Yost, R. A. 1985. "Tandem mass spectrometry for trace analysis." *Anal. Chem.*, 57, 758A–768A.
- Josephs, J. L. 1996. "Detection and characterization of fumonisin mycotoxins by liquid chromatography/electrospray ionization using ion trap and triple quadrupole mass spectrometry." *Rapid Commun. Mass Spectrom.*, 10, 1333–1344.

- Joyce, K. B.; Jones, A. E.; Scott, R. J.; Biddlecombe, R. A.; Pleasance, S. 1998. "Determination of the enantiomers of salbutamol and its 4-O-sulphate metabolites in biological matrices by chiral liquid chromatography tandem mass spectrometry." *Rapid Commun. Mass Spectrom.*, *12*, 1899–1910.
- Julian, R. K.; Higgs, R. E.; Gygi, J. D.; Hilton, M. D. 1998. "A method for quantitatively differentiating crude natural extracts using high-performance liquid chromatography-electrospray mass spectrometry." *Anal. Chem.*, *70*, 3249–3254.
- Jurva, U.; Wikström, H. V.; Bruins, A. P. 2000. "In vitro mimicry of metabolic oxidation reactions by electrochemistry/mass spectrometry." *Rapid Commun. Mass Spectrom.*, *14*, 529–533.
- Kanazawa, H.; Konishi, Y.; Matsushima, Y.; Takahashi, T. 1998. "Determination of sedatives and anesthetics in plasma by liquid chromatography-mass spectrometry with a desalting system." *J. Chromatogr. A*, *797*, 227–236.
- Kassel, D. B.; Shushan, B.; Sakuma, T.; Salzmann, J. P. 1994. "Evaluation of packed capillary perfusion column HPLC/MS/MS for the rapid mapping and sequencing of enzymatic digests." *Anal. Chem.*, *66*, 236–243.
- Kaur, S.; McGuire, L.; Tang, D.; Dollinger, G.; Huebner, V. 1997. "Affinity selection and mass spectrometry-based strategies to identify lead compounds in combinatorial libraries." *J. Prot. Chem.*, *16*, 505–511.
- Kaye, B.; Clark, M. W.; Cussans, N. J.; Macrae, P. V.; Stopher, D. A. 1992. "The sensitive determination of abanoquil in blood by high-performance liquid chromatography/atmospheric pressure ionization mass spectrometry." *Biol. Mass Spectrom.*, *21*, 585–589.
- Kaye, B.; Herron, W. J.; Macrae, P. V.; Robinson, S.; Stopher, D. A.; Venn, R. F.; Wild, W. 1996. "Rapid, solid phase extraction technique for the high-throughput assay of darifenacin in human plasma." *Anal. Chem.*, *68*, 1658–1660.
- Kelleher, N. L. 2000. "From primary structure to function: biological insights from large-molecule mass spectra." *Chem. Biol.*, *7*, R37–R45.
- Kelleher, N. L.; Lin, H. Y.; Valaskovic, G. A.; Aaserud, D. L.; Fridriksson, E. K.; McLafferty, F. W. 1999. "Top down versus bottom up protein characterization by tandem high-resolution mass spectrometry." *J. Am. Chem. Soc.*, *121*, 806–812.
- Kennedy, R. T.; Jorgenson, J. W. 1989. "Preparation and evaluation of packed capillary liquid chromatography columns with inner diameters from 20 to 50 μm ." *Anal. Chem.*, *61*, 1128–1135.
- Kerns, E. H.; Volk, K. J.; Hill, S. E.; Lee, M. S. 1994. "Profiling taxanes in *taxus* extracts using LC/MS and LC/MS/MS techniques." *J. Nat. Prod.*, *57*, 1391–1403.

- Kerns, E. H.; Volk, K. J.; Hill, S. E.; Lee, M. S. 1995. "Profiling new taxanes using LC/MS and LC/MS/MS substructural analysis techniques." *J. Rapid Commun. Mass Spectrom.*, *9*, 1539–1545.
- Kerns, E. H.; Rourick, R. A.; Volk, K. J.; Lee, M. S. 1997. "Buspirone metabolite structure profile using a standard liquid chromatographic-mass spectrometric protocol." *J. Chromatogr. B*, *698*, 133–145.
- Kerns, E. H.; Hill, S. E.; Detlefsen, D. J.; Long, B. H.; Carboni, J.; Lee, M. S. 1998. "Cellular uptake profile of paclitaxel using liquid chromatography tandem mass spectrometry." *J. Rapid Commun. Mass Spectrom.*, *12*, 620–624.
- King, R.; Bonfiglio, R.; Fernandez-Metzler, C.; Miller-Stein, C.; Olah, T. 2000. "Mechanistic investigation of ionization suppression in electrospray ionization." *J. Am. Soc. Mass Spectrom.*, *11*, 942–950.
- Kleintop, B.; Volk, K.; Hail, M.; Sanders, M.; Reddick, C.; Bolgar, M.; Warrack, B.; Liu, J.; Detlefsen, D.; Kerns, E.; Lee, M. 1998. "Predictive degradation profiling of biomolecules using LC/MS methodologies." *Proc. 46th ASMS Conf. Mass Spectrom. and Allied Topics* (Orlando, Florida), 240.
- Kolb, A. J.; Neumann, K. 1997. "Beyond the 96-well microplate: instruments and assay methods for the 384-well format." *J. Biomol. Screening*, *2*, 103–109.
- Kolthoff, I. M. 1973. "Development of analytical chemistry as a science." *Anal. Chem.*, *45*, 25A–37A.
- Korfmacher, W. A.; Palmer, C. A.; Nardo, C.; Dunn-Meynell, K.; Grotz, D.; Cox, K.; Lin, C. C.; Elicone, C.; Liu, C.; Duchoslav, E. 1999. "Development of an automated mass spectrometry system for the quantitative analysis of liver microsomal incubation samples: a tool for rapid screening of new compounds for metabolic stability." *Rapid Commun. Mass Spectrom.*, *13*, 901–907.
- Korfmacher, W. A.; Cox, K. A.; Ng, K. J.; Veals, J.; Hsieh, Y.; Wainhaus, S.; Broske, L.; Prelusky, D.; Nomeir, A.; White, R. E. 2001. "Cassette-accelerated rapid rat screen: a systematic procedure for the dosing and liquid chromatography/atmospheric pressure ionization tandem mass spectrometric analysis of new chemical entities as part of new drug discovery." *Rapid Commun. Mass Spectrom.*, *15*, 335–340.
- Kusmierz, J. J.; Sumrada, R.; Desiderio, D. M. 1990. "Fast atom bombardment mass spectrometric quantitative analysis of methionine-enkephalin in human pituitary tissues." *Anal. Chem.*, *62*, 2395–2400.
- Kyranos, J. N.; Hogan, J. C. 1998. "High-throughput characterization of combinatorial libraries generated by parallel synthesis." *Anal. Chem.*, *70*, 389A–395A.
- Laitinen, H. A. 1973. "The seven ages of an analytical method." *Anal. Chem.*, *45*, 2305.

- Laitinen, H. A. 1980. "Analytical chemistry in a changing world." *Anal. Chem.*, 52, 605A–612A.
- Lam, K. S. 1997. "Application of combinatorial library methods in cancer research and drug discovery." *Anticancer Drug Des.*, 12, 145–167.
- Lane, S. J.; Pipe, A. 1999. "A single generic microbore liquid chromatography/time-of-flight mass spectrometry solution for the simultaneous accurate mass determination of compounds on single beads, the decoding of dansylated orthogonal tags pertaining to compounds and accurate isotopic difference target analysis." *Rapid Commun. Mass Spectrom.*, 13, 798–814.
- Lant, M. S.; Martin, L. E.; Oxford, J. 1985. "Qualitative and quantitative analysis of ranitidine and its metabolites by high-performance liquid chromatography-mass spectrometry." *J. Chromatogr.*, 323, 143–152.
- Lee, E. D.; Henion, J. D. 1985. "Micro-liquid chromatography/mass spectrometry with direct liquid introduction." *J. Chromatogr. Sci.*, 23, 253–264.
- Lee, M. G.; Millard, B. J. 1975. "A comparison of unlabelled and labelled internal standards for quantification by single and multiple ion monitoring." *J. Biomed. Mass Spectrom.*, 2, 78–81.
- Lee, M. S.; Kerns, E. H. 1998. "High throughput drug metabolite analysis using LC/MS screening methods." British Mass Spectrometry Society 23rd Annual Meeting, University of Warrick, UK.
- Lee, M. S.; Kerns, E. H. 1999. "LC/MS applications in drug development." *Mass Spectrom. Rev.*, 18, 187–279.
- Lee, M. S.; Yost, R. A. 1988. "Rapid identification of drug metabolites with tandem mass spectrometry." *Biomed. Env. Mass Spectrom.*, 15, 193–204.
- Lee, M. S.; Yost, R. A.; Perchalski, R. J. 1986. "Tandem mass spectrometry and drug metabolism." *Annu. Rep. Med. Chem.*, 21, 313–321.
- Lee, M. S.; Kerns, E. H.; DiDonato, G. C.; Gedamke, R.; Hail, M. E.; Klohr, S. E.; Rourick, R.; Starrett, A. M.; Taylor, S. C.; Thompson, W. L.; Volk, K. J.; Warrack, B. M.; Whitney, J. L. 1995a. "Diversity profiling: rapid pharmaceutical development based on ESI/MS." *Proc. 43rd ASMS Conf. Mass Spectrom. and Allied Topics* (Atlanta, Georgia), 148.
- Lee, M. S.; Volk, K. J.; Liu, J.; Pucci, M. J.; Handwerker, S. 1995b. "Identification of a cytoplasmic peptidoglycan precursor in antibiotic-resistant bacteria." In *Biochemical and Biotechnological Applications of Electro-spray Ionization Mass Spectrometry*, Snyder, A. P., ed., Washington, D.C.: American Chemical Society, 619, 106–129.
- Lee, M. S.; Klohr, S. E.; Kerns, E. H.; Volk, K. J.; Leet, J. E.; Schroeder, D. R.; Rosenberg, I. E. 1996. "The coordinated use of tandem mass spectrometry and high resolution mass spectrometry for the structure elucidation of the kedarcidin chromophore." *J. Mass Spectrom.*, 31, 1253–1260.

- Lee, M. S.; Kerns, E. H.; Hail, M. E.; Liu, J.; Volk, K. J. 1997. "Recent applications of LC-MS techniques for the structure identification of drug metabolites and related compounds." *LC•GC*, 15, 542–558.
- Li, C.; Chauret, N.; Ducharme, Y.; Trimble, L. A.; Nicoll-Griffith, D. A.; Yergey, J. A. 1995. "Integrated application of capillary HPLC/continuous-flow liquid secondary ion mass spectrometry to discovery stage metabolism studies." *Anal. Chem.*, 67, 2931–2936.
- Li, M. X.; Wu, J. T.; Parus, S.; Lubman, D. M. 1998. "Development of a three-dimensional topographic map display for capillary electrophoresis/mass spectrometry with an ion trap/reflectron time-of-flight mass spectrometer detector: applications to tryptic digests of isoforms of myelin basic protein." *J. Am. Soc. Mass Spectrom.*, 9, 701–709.
- Licklider, L.; Wang, X.-Q.; Desai, A.; Tai, Y.-C.; Lee, T. D. 2000. "A micro-machined chip-based electrospray source for mass spectrometry." *Anal. Chem.*, 72, 367–375.
- Ling, V.; Guzzetta, A. W.; Canova-Davis, E.; Stults, J. T.; Hancock, W. S.; Covey, T. R.; Shushan, B. I. 1991. "Characterization of the tryptic map of recombinant DNA derived tissue plasminogen activator by high-performance liquid chromatography-electrospray ionization mass spectrometry." *Anal. Chem.*, 63, 2909–2915.
- Link, A. J.; Eng, J.; Schielz, D. M.; Carmack, E.; Mize, G. J.; Morris, D. R.; Garvik, B. M.; Yates, J. R., III. 1999. "Direct analysis of protein complexes using mass spectrometry." *Nat. Biotechnol.*, 17, 676–682.
- Lippman, M.; Mok, M. S.; Steen, S. N.; Lane, A. Z.; Caruso, F. S. 1977. "Analgesic onset time of intravenous butorphanol in post surgical patients: a placebo-controlled study." *Curr. Ther. Res.*, 22, 276–283.
- Liu, J.; Volk, K. J.; Kerns, E. H.; Klohr, S. E.; Lee, M. S.; Rosenberg, I. E. 1993. "Structural characterization of glycoprotein digest by microcolumn liquid chromatography-ionspray tandem mass spectrometry." *J. Chromatogr.*, 632, 45–56.
- Liu, J.; Zhao, H.; Volk, K. J.; Klohr, S. E.; Kerns, E. H.; Lee, M. S. 1996. "Analysis of monoclonal antibody and immunoconjugate digests by capillary electrophoresis and capillary liquid chromatography." *J. Chromatogr. A*, 735, 357–366.
- Liu, J.; Volk, K. J.; Mata, M. J.; Kerns, E. H.; Lee, M. S. 1997. "Analysis of amino acid enantiomers derived from antitumor antibiotics using chiral capillary electrophoresis." *J. Pharm. Biomed. Anal.*, 15, 1729–1739.
- Liu, J. L.; Lu, K. V.; Eris, T.; Katta, V.; Westcott, K. R.; Narhi, L. O.; Lu, H. S. 1998. "In vitro methionine oxidation of recombinant human leptin." *Pharm. Res.*, 15, 632–640.
- Loboda, A. V.; Krutchinsky, A. N.; Bromirski, M.; Ens, W.; Standing, K. G. 2000. "A tandem quadrupole/time-of-flight mass spectrometer with a

- matrix-assisted laser desorption/ionization source: design and performance." *Rapid Commun. Mass Spectrom.*, *14*, 1047–1057.
- Lokiec, F.; du Sorbier, B. M.; Sanderink, G. J. 1996. "Irinotecan (CPT-11) metabolites in human bile and urine." *Clin. Cancer Res.*, *2*, 1943–1949.
- Lopez, L. L.; Yu, X.; Cui, D.; Davis, M. R. 1998. "Identification of drug metabolites in biological matrices by intelligent automated liquid chromatography/tandem mass spectrometry." *Rapid Commun. Mass Spectrom.*, *12*, 1756–1760.
- Malcolm, S. L.; Madigan, M. J.; Taylor, N. L. 1990. "Thermospray mass spectrometer as a quantitative specific, sensitive, detector for liquid chromatography. Its application to the analysis of pyridostigmine in human plasma." *J. Pharm. Biomed. Anal.*, *8*, 771–776.
- Manini, P.; Andreoli, R.; Mutti, A.; Bergamaschi, E.; Niessen, W. M. 1998. "Determination of n-hexane metabolites by liquid chromatography/mass spectrometry. 2. Glucuronide-conjugated metabolites in untreated urine samples by electrospray ionization." *Rapid Commun. Mass Spectrom.*, *12*, 1615–1624.
- Mann, M. 1999. "Quantitative proteomics?" *Nat. Biotechnol.*, *17*, 954–955.
- Matuszewski, B. K.; Constanzer, M. L.; Chavez-Eng, C. M. 1998. "Matrix effect in quantitative LC/MS/MS analyses of biological fluids: a method for determination of finasteride in human plasma at picogram per milliliter concentrations." *Anal. Chem.*, *70*, 882–889.
- Maurer, H. H.; Kraemer, T.; Ledvinka, O.; Schmitt, C. J.; Weber, A. A. 1997. "Gas chromatography-mass spectrometry (GC-MS) and liquid chromatography-mass spectrometry (LC-MS) in toxicological analysis. Studies on the detection of clobenzorex and its metabolites within a systematic toxicological analysis procedure by GC-MS and by immunoassay and studies on the detection of alpha- and beta-amanitin in urine by atmospheric pressure ionization electrospray LC-MS." *J. Chromatogr. B Biomed. Sci. Appl.*, *689*, 81–89.
- Mazaroff, I.; Yu, W.; Kelley, B. D.; Vath, J. E. 1997. "Quantitative comparison of global carbohydrate structures of glycoproteins using LC-MS and in-source fragmentation." *Anal. Chem.*, *69*, 2517–2524.
- McCormack, A. L.; Schieltz, D. M.; Goode, B.; Yang, S.; Barnes, G.; Drubin, D.; Yates, J. R. III. 1997. "Direct analysis and identification of proteins in mixtures by LC/MS/MS and database searching at the low-femtomole level." *Anal. Chem.*, *69*, 767–776.
- McLafferty, F. W., ed., 1983. *Tandem Mass Spectrometry*, New York: John Wiley and Sons.
- Medzihradsky, K. F.; Maltby, D. A.; Hall, S. C.; Settineri, C. A.; Burlingame, A. L. 1994. "Characterization of protein N-glycosylation by reversed-phase microbore liquid chromatography/electrospray mass spectrometry."

- try, complementary mobile phases, and sequential exoglycosidase digestion." *J. Am. Soc. Mass Spectrom.*, 5, 350–358.
- Medzihradzky, K. F.; Besman, M. J.; Burlingame, A. L. 1998. "Reverse-phase capillary high performance liquid chromatography/high performance electrospray ionization mass spectrometry: an essential tool for the characterization of complex glycoprotein digests." *Rapid Commun. Mass Spectrom.*, 12, 472–478.
- Moos, W. H.; Green, G. D.; Pavia, M. R. 1993. "Recent advances in the generation of molecular diversity." *Annu. Rep. Med. Chem.*, 28, 315–324.
- Morris, H. R.; Paxton, T.; Dell, A.; Langhorne, J.; Berg, M.; Bordoli, R. S.; Hoyes, J.; Bateman, R. H. 1996. "High sensitivity collisionally-activated decomposition tandem mass spectrometry on a novel quadrupole/orthogonal-acceleration time-of-flight mass spectrometer." *Rapid Commun. Mass Spectrom.*, 10, 889–896.
- Moseley, M. A.; Deterding, L. J.; Tomer, K. B.; Jorgenson, J. W. 1991. "Nanoscale packed-capillary liquid chromatography coupled with mass spectrometry using a coaxial continuous-flow fast atom bombardment interface." *Anal. Chem.*, 63, 1467–1473.
- Moy, F. J.; Haraki, K.; Mobilio, D.; Walker, G.; Powers, R.; Tabei, K.; Tong, H.; Siegel, M. M. 2001. "MS/NMR: A structure-based approach for discovering protein ligands and for drug design by coupling size exclusion chromatography, mass spectrometry, and nuclear magnetic resonance spectroscopy." *Anal. Chem.*, 73, 571–581.
- Mutlib, A. E.; Strupczewski, J. T.; Chesson, S. M. 1995. "Application of hyphenated LC/NMR and LC/MS techniques in rapid identification of in vitro and in vivo metabolites of iloperidone." *Drug Metab. Dispos.*, 23, 951–964.
- Nadin, A.; Nicolaou, K. C. 1996. "Chemistry and biology of the zaragoic acids (squalestatins)." *Angew. Chem. Int. Ed. Engl.*, 35, 1622–1656.
- Nagel, B.; Dellweg, H.; Gierasch, L. M. 1992. "Glossary for chemists of terms used in biotechnology." *Pure Appl. Chem.*, 64, 143–168.
- Nedved, M. L.; Habibi-Goudarzi, S.; Ganem, B.; Henion, J. D. 1996. "Characterization of benzodiazepine 'combinatorial' chemical libraries by on-line immunoaffinity extraction, coupled column HPLC-ion spray mass spectrometry-tandem mass spectrometry." *Anal. Chem.*, 68, 4228–4236.
- Needham, S. R.; Cole, M. J.; Fouda, H. G. 1998. "Direct plasma injection for high-performance liquid chromatographic-mass spectrometric quantitation of the anxiolytic agent CP-93 393." *J. Chromatogr. B*, 718, 87–94.
- Nicolas, E. C.; Scholz, T. H. 1998. "Active drug substance impurity profiling part II. LC/MS/MS fingerprinting." *J. Pharm. Biomed. Anal.*, 16, 825–836.

- Niessen, W. M. 1998. "Advances in instrumentation in liquid chromatography-mass spectrometry and related liquid-introduction techniques." *J. Chromatogr. A*, 794, 407-435.
- Oda, Y.; Huang, K.; Cross, F. R.; Cowburn, D.; Chait, B. T. 1999. "Accurate quantitation of protein expression and site-specific phosphorylation." *Proc. Natl Acad. Sci. USA*, 96, 6591-6596.
- Olah, T. V.; McLoughlin, D. A.; Gilbert, J. D. 1997. "The simultaneous determination of mixtures of drug candidates by liquid chromatography/atmospheric pressure chemical ionization mass spectrometry as an in vivo drug screening procedure." *Rapid Commun. Mass Spectrom.*, 11, 17-23.
- Oxford, J.; Lant, M. S. 1989. "Development and validation of a liquid chromatographic-mass spectrometric assay for the determination of sumatriptan in plasma." *J. Chromatogr.*, 496, 137-146.
- Pandey, A.; Mann, M. 2000. "Proteomics to study genes and genomes." *Nature*, 405, 837-846.
- Park, S.; Wanna, L.; Johnson, M. E.; Venton, D. L. 2000. "A mass spectrometry screening method for antiaggregatory activity of proteins covalently modified by combinatorial library members: application to sickle hemoglobin." *J. Comb. Chem.*, 2, 314-317.
- Patchett, A. A. 1993. "Excursions in drug discovery." *J. Med. Chem.*, 36, 2051-2058.
- Peng, S. X.; Borah, B.; Dobson, R. L. M.; Liu, Y. D.; Pikul, S. 1999. "Application of LC-NMR and LC-MS to the identification of degradation products of a protease inhibitor in dosage formulations." *J. Pharm. Biomed. Anal.*, 20, 75-89.
- Perchalski, R. J.; Yost, R. A.; Wilder, B. J. 1982. "Structural elucidation of drug metabolites by triple-quadrupole mass spectrometry." *Anal. Chem.*, 54, 1466-1471.
- Perico, N.; Remuzzi, G. 1996. "New antirejection drugs." *Exp. Opin. Ther. Patents*, 6, 871-891.
- Pettit, G. R. 1994. "Marine animal and terrestrial plant anticancer constituents." *Pure Appl. Chem.*, 66, 2271-2281.
- Poon, G. K.; Wade, J.; Bloomer, J.; Clarke, S. E.; Maltas, J. 1996. "Rapid screening of taxol metabolites in human microsomes by liquid chromatography/electrospray ionization-mass spectrometry." *Rapid Commun. Mass Spectrom.*, 10, 1165-1168.
- Poon, G. K.; Kwei, G.; Wang, R.; Lyons, K.; Chen, Q.; Didolkar, V.; Hop, C. E. 1999. "Integrating qualitative and quantitative liquid chromatography/tandem mass spectrometric analysis to support drug discovery." *Rapid Commun. Mass Spectrom.*, 13, 1943-1950.

- Pramanik, B. N.; Bartner, P. L.; Chen, G. 1999. "The role of mass spectrometry in drug discovery process." *Current Opinion in Drug Discovery*, 2, 401–417.
- Pramanik, B. N.; Ganguly, A. K.; Gross, M. L., eds. 2001. *Applied Electrospray Mass Spectrometry*, New York: Marcel Dekker.
- Pullen, F. S.; Kerkins, G. L.; Burton, K. I.; Ware, R. S.; Teague, M. S.; Kiplinger, J. P. 1995. "Putting mass spectrometry in the hands of the end user." *J. Am. Soc. Mass Spectrom.*, 6, 394–399.
- Qin, X. Z.; Ip, D. P.; Chang, K. H.; Dradransky, P. M.; Brooks, M. A.; Sakuma, T. 1994. "Pharmaceutical application of LC-MS. 1—Characterization of a famotidine degradate in package screening study by LC-APCI MS." *J. Pharm. Biomed. Anal.*, 12, 221–233.
- Ramsey, R. S.; Ramsey, J. M. 1997. "Generating electrospray from microchip devices using electroosmotic pumping." *Anal. Chem.*, 69, 1174–1178.
- Regnier, F. E. 1991. "Perfusion chromatography." *Nature*, 350, 634–635.
- Reinhold, V. N.; Reinhold, B. B.; Costello, C. E. 1995. "Carbohydrate molecular weight profiling, sequence, linkage, and branching data: ES-MS and CID." *Anal. Chem.*, 67, 1772–1784.
- Richmond, R.; Gorlach, E.; Seifert, J. M. 1999. "High-throughput flow injection analysis-mass spectrometry with networked delivery of colour rendered results: the characterization of liquid chromatography fractions." *J. Chromatogr. A*, 835, 29–39.
- Roepstorff, P.; Fohlman, J. 1984. "Proposal for a common nomenclature for sequence ions in mass spectra of peptides." *Biomed. Mass Spectrom.*, 11, 601–602.
- Romanyshyn, L.; Tiller, P. R.; Alvaro, R.; Pereira, A.; Hop, C. E. C. A. 2001. "Ultra-fast gradient vs. fast isocratic chromatography in bioanalytical quantification by liquid chromatography/tandem mass spectrometry." *Rapid Commun. Mass Spectrom.*, 15, 313–319.
- Rourick, R. A.; Volk, K. J.; Kerns, E. K.; Lee, M. S. 1996. "Predictive strategy for the rapid structure elucidation of drug degradants." *J. Pharm. Biomed. Anal.*, 14, 1743–1752.
- Rourick, R. A.; Fink, S. W.; Volk, K. J.; Whitney, J. L.; Klohr, S. E.; Kerns, E. H.; Lee, M. S. 1998. "The impact of LC/MS based structure profile libraries on the drug discovery-development continuum." *Proc. 46th ASMS Conf. Mass Spectrom. and Allied Topics* (Orlando, Florida), 17.
- Rubas, W.; Jezyk, N.; Grass, G. M. 1993. "Comparison of the permeability characteristics of a human colonic epithelial (Caco-2) cell line to colon of rabbit, monkey, and dog intestine and human drug absorption." *Pharm. Res.*, 10, 113–118.

- Schriemer, D. C.; Hindsgaul, O. 1998. "Deconvolution approaches in screening compound mixtures." *Comb. Chem. High Throughput Screen*, *1*, 155–170.
- Schultz, G. A.; Corso, T. N.; Prosser, S. J.; Zhang, S. 2000. "A fully integrated monolithic microchip electrospray device for mass spectrometry." *Anal. Chem.*, *72*, 4058–4063.
- Scott, D. O.; Heath, T. G. 1998. "Investigation of the CNS penetration of a potent 5-HT_{2a} receptor antagonist (MDL 100,907) and an active metabolite (MDL 105,725) using in vivo microdialysis sampling in the rat." *J. Pharm. Biomed. Anal.*, *17*, 17–25.
- Scott, R. J.; Palmer, J.; Lewis, I. A.; Pleasance, S. 1999. "Determination of a 'GW cocktail' of cytochrome P450 probe substrates and their metabolites in plasma and urine using automated solid phase extraction and fast gradient liquid chromatography tandem mass spectrometry." *Rapid Commun. Mass Spectrom.*, *13*, 2305–2319.
- Self, R. 1979. "A polemic on the uses and functions of deuterated analogues in quantitative mass spectrometry." *Biomed. Mass Spectrom.*, *6*, 315–316.
- Selway, C. N.; Terrett, N. K. 1996. "Parallel-compound synthesis: methodology for accelerating drug discovery." *Bioorg. Med. Chem.*, *4*, 645–654.
- Shaffer, J. E.; Adkison, K. K.; Halm, K.; Hedeen, K.; Berman, J. 1999. "Use of 'n-in-one' dosing to create an in vivo pharmacokinetics database for use in developing structure-pharmacokinetic relationships." *J. Pharm. Sci.*, *88*, 313–318.
- Shah, N.; Gao, M.; Tsutsui, K.; Lu, A.; Davis, J.; Scheuerman, R.; Fitch, W. L.; Wilgus, R. L. 2000. "A novel approach to high-throughput quality control of parallel synthesis libraries." *J. Comb. Chem.*, *2*, 453–460.
- Sharma, J.; Panico, M.; Barber, J.; Morris, H. R. 1997. "Purification and determination of intact molecular mass by electrospray ionization mass spectrometry of the photosystem II reaction center subunits." *J. Biol. Chem.*, *272*, 33153–33157.
- Shevchenko A.; Chernushevich, I.; Ens, W.; Standing, K. G.; Thomson, B.; Wilm, M.; Mann, M. 1997. "Rapid 'de novo' peptide sequencing by a combination of nanoelectrospray, isotopic labeling and a quadrupole/time-of-flight mass spectrometer." *Rapid Commun. Mass Spectrom.*, *11*, 1015–1024.
- Shevchenko, A.; Loboda, A.; Shevchenko, A.; Ens, W.; Standing, K. G. 2000. "MALDI quadrupole time-of-flight mass spectrometry: a powerful tool for proteomic research." *Anal. Chem.*, *72*, 2132–2141.
- Shockcor, J. P.; Unger, S. E.; Wilson, I. D.; Foxall, J. P.; Nicholson, J. K.; Lindon, J. C. 1996. "Combined HPLC, NMR spectroscopy, and ion-trap mass spectrometry with application to the detection and characterization of xenobiotic and endogenous metabolites in human urine." *Anal. Chem.*, *68*, 4431–4435.

- Shockcor, J. P.; Unger, S. E.; Savina, P.; Nicholson, J. K.; Lindon, J. C. 2000. "Application of directly coupled LC-NMR-MS to the structural elucidation of metabolites of the HIV-1 reverse-transcriptase inhibitor BW935U83." *J. Chromatogr. B Biomed. Sci. Appl.*, *748*, 269–279.
- Simpson, H.; Berthemy, A.; Buhrman, D.; Burton, R.; Newton, J.; Kealy, M.; Wells, D.; Wu, D. 1998. "High throughput liquid chromatography/mass spectrometry bioanalysis using 96-well disk solid phase extraction plate for the sample preparation." *Rapid Commun. Mass Spectrom.*, *12*, 75–82.
- Smith, R. D.; Johnson, A. L. 1981. "Deposition method for moving ribbon liquid chromatograph-mass spectrometer interfaces." *Anal. Chem.*, *53*, 739–740.
- Smith, R. D.; Light-Wahl, K. J. 1993. "The observation of non-covalent interactions in solution by electrospray ionization mass spectrometry: promise, pitfalls and prognosis." *Biol. Mass Spectrom.*, *22*, 493–501.
- Snyder, A. P. 1995. "Electrospray: a popular ionization technique for mass spectrometry." In *Biochemical and Biotechnological Applications of Electrospray Ionization Mass Spectrometry*; Snyder, A. P., ed., Washington, D.C.: American Chemical Society. 619, 1–20.
- Snyder, L. R.; Kirkland, J. J. 1979. *Introduction to Modern Liquid Chromatography*, New York: John Wiley and Sons.
- Speir, J. P.; Perkins, G.; Berg, C.; Pullen, F. 2000. "Fast, generic gradient high performance liquid chromatography coupled to Fourier transform ion cyclotron resonance mass spectrometry for the accurate mass analysis of mixtures." *Rapid Commun. Mass Spectrom.*, *14*, 1937–1942.
- Stevens, G. J.; Hitchcock, K.; Wang, Y. K.; Coppola, G. M.; Versace, R. W.; Chin, J. A.; Shapiro, M.; Suwanrumpha, S.; Mangold, B. L. 1997. "In vitro metabolism of N-(5-chloro-2-methylphenyl)-N'-(2-methylpropyl) thiourea: species comparison and identification of a novel thiocarbamide-glutathione adduct." *Chem. Res. Toxicol.*, *10*, 733–741.
- Stevenson, T. I.; Loo, J. A.; Greis, K. D. 1998. "Coupling capillary high-performance liquid chromatography to matrix-assisted laser desorption/ionization mass spectrometry and N-terminal sequencing of peptides via automated microblotting onto membrane substrates." *Anal. Biochem.*, *262*, 99–109.
- Stoeckli, M.; Farmer, T. B.; Caprioli, R. M. 1999. "Automated mass spectrometry imaging with a matrix-assisted laser desorption ionization time-of-flight instrument." *J. Am. Soc. Mass Spectrom.*, *10*, 67–71.
- Storer, R. 1996. "Solution-phase synthesis in combinatorial chemistry: applications in drug discovery." *Drug Discovery Today*, *1*, 248–254.
- Straub, K. M.; Rudewicz, P.; Garvie, C. 1987. "'Metabolic mapping' of drugs: rapid screening techniques for xenobiotic metabolites with m.s./m.s. techniques." *Xenobiotica*, *17*, 413–422.

- Strege, M. A. 1999. "High-performance liquid chromatographic-electrospray ionization mass spectrometric analyses for the integration of natural products with modern high-throughput screening." *J. Chromatogr. B*, 725, 67–78.
- Süßmuth, R. D.; Jung, G. 1999. "Impact of mass spectrometry on combinatorial chemistry." *J. Chromatogr. B Biomed. Sci. Appl.*, 725, 49–65.
- Swali, V.; Langley, G. J.; Bradley, M. 1999. "Mass spectrometric analysis in combinatorial chemistry." *Curr. Opin. Chem. Biol.*, 3, 337–341.
- Swiderek, K. M.; Davis, M. T.; Lee, T. D. 1998. "The identification of peptide modifications derived from gel-separated proteins using electrospray triple quadrupole and ion trap analyses." *Electrophoresis*, 19, 989–997.
- Taaffe, P. 1996. "Outsourcing in the pharmaceutical industry," *Financial Times Management Report*.
- Tamvakopoulos, C. S.; Colwell, L. F.; Barakat, K.; Fenyk-Melody, J.; Griffin, P. R.; Rargund, R.; Palucki, B.; Sebhat, I.; Shen, X.; Stearns, R. A. 2000. "Determination of brain and plasma drug concentrations by liquid chromatography/tandem mass spectrometry." *Rapid Commun. Mass Spectrom.*, 14, 1729–1735.
- Taniguchi, H.; Hayashi, N. 1998. "A liquid chromatography/electrospray mass spectrometric study on the post-transcriptional modification of tRNA." *Nucleic Acids Res.*, 26, 1481–1486.
- Tang, K.; Lin, Y.; Matson, D. W.; Kim, T.; Smith, R. D. 2001. "Generation of multiple electrosprays using microfabricated emitter arrays for improved mass spectrometric sensitivity." *Anal. Chem.*, 73, 1658–1663.
- Taylor, L. C. E.; Johnson, R. L.; Raso, R. 1995. "Open access atmospheric pressure chemical ionization mass spectrometry for routine sample analysis." *J. Am. Soc. Mass Spectrom.*, 6, 387–393.
- Taylor, J. A.; Johnson, R. S. 2001. "Implementation and uses of automated de novo peptide sequencing by tandem mass spectrometry." *Anal. Chem.*, 73, 2594–2604.
- Terrett, N. K.; Bell, A. S.; Brown, D.; Ellis, P. 1996. "Sildenafil (Viagra), a potent and selective inhibitor of type 5 cGMP phosphodiesterase with utility for the treatment of male erectile dysfunction." *Bioorg. Med. Chem. Lett.*, 6, 1819–1824.
- Thompson, W. L. 1995. "Research investments in a managed care, cost-containment oligopsony." *Annu. Rep. Med. Chem.*, 30, 339–345.
- Thomson, B. A. 1998. "Atmospheric pressure ionization and liquid chromatography/mass spectrometry-together at last." *J. Am. Soc. Mass Spectrom.*, 9, 187–193.
- Thomson, B. A.; Iribarne, J. V. 1979. "Field induced ion evaporation from liquid surfaces at atmospheric pressure." *J. Chem. Phys.*, 71, 4451–4463.

- Tiller, P. R.; Mutton, I. M.; Lane, S. J.; Bevan, C. D. 1995. "Immobilized human serum albumin: liquid chromatography/mass spectrometry as a method of determining drug-protein binding." *Rapid Commun. Mass Spectrom.*, *9*, 261–263.
- Tiller, P. R.; El Fallah, Z.; Wilson, V.; Juysman, J.; Patel, D. 1997a. "Qualitative assessment of leachables using data-dependent liquid chromatography/mass spectrometry and liquid chromatography/tandem mass spectrometry." *Rapid Commun. Mass Spectrom.*, *11*, 1570–1574.
- Tiller, P. R.; Cunniff, J.; Land, A. P.; Schwartz, J.; Jardine, I.; Wakefield, M.; Lopez, L.; Newton, J. F.; Burton, R. D.; Folk, B. M.; Buhrman, D. L.; Price, P.; Wu, D. 1997b. "Drug quantitation on a benchtop liquid chromatography-tandem mass spectrometry system." *J. Chromatogr. A*, *771*, 119–125.
- Tiller, P. R.; Land, A. P.; Jardine, I.; Murphy, D. M.; Sozio, R.; Ayrton, A.; Schaefer, W. H. 1998. "Application of liquid chromatography-mass spectrometry analyses to the characterization of novel glyburide metabolites formed in vitro." *J. Chromatogr. A*, *794*, 15–25.
- Tomoda, H.; Kim, Y. K.; Nishida, H.; Musuma, R.; Omura, S. 1994. "Pyripyropenes, novel inhibitors of acyl-CoA:Cholesterol acyltransferase produced by *Aspergillus fumigatus*. I. Production, isolation, and biological properties." *J. Antibiotics*, *47*, 148–153.
- Tong, H.; Bell, D.; Keiko, T.; Siegel, M. M. 1999. "Automated data massaging, interpretation and e-mailing for high throughput open access mass spectrometry." *J. Am. Soc. Mass Spectrom.*, *10*, 1174–1187.
- Turner, W. W.; Rodriguez, M. J. 1996. "Recent advances in the medicinal chemistry of antifungal agents." *Curr. Pharm. Des.*, *2*, 209–224.
- Unger, S. E. 1999. "Using mass spectrometry to determine ADME properties in drug discovery." *Annu. Rep. Med. Chem.*, *34*, 307–316.
- van Breeman, R. B.; Bartlett, M. G.; Tsou, Y. H.; Culver, C.; Swaisgood, H.; Unger, S. E. 1991. "Degradation of peptide drugs by immobilized digestive proteases." *Drug Metab. Dispos.*, *19*, 683–690.
- van Breeman, R. B.; Huang, C.-R.; Nikolic, D.; Woodbury, C. P.; Zhao, Y.-Z.; Venton, D. L. 1997. "Pulsed ultrafiltration mass spectrometry: a new method for screening combinatorial libraries." *Anal. Chem.*, *69*, 2159–2164.
- van Breeman, R. B.; Nikolic, D.; Bolton, J. L. 1998. "Metabolic screening using on-line ultrafiltration mass spectrometry." *Drug Metab. Dispos.*, *26*, 85–90.
- Van Hijfte, L.; Marciniak, G.; Froloff, N. 1999. "Combinatorial chemistry, automation and molecular diversity: new trends in the pharmaceutical industry." *J. Chromatogr. B Biomed. Sci. Appl.*, *725*, 3–15.
- Ventura, M. C.; Farrell, W. P.; Aurigemma, C. M.; Xiong, X.; Osonubi, M. O.; Lopez, R.; Greig, M. J. 2000. "Optimizing quality control of combinato-

- rial libraries with SFC/MS." *Proc. 48th ASMS Conf. Mass Spectrom. and Allied Topics*, (Long Beach, California), 202–203.
- Vogler, B.; Klaiber, I.; Roos, G.; Walter, C. U.; Hiller, W.; Sandor, P.; Kraus, W. 1998. "Combination of LC-MS and LC-NMR as a tool for the structure determination of natural products." *J. Nat. Prod.*, *61*, 175–178.
- Volk, K. J.; Klohr, S. E.; Rourick, R. A.; Kerns, E. H.; Lee, M. S. 1996. "Profiling impurities and degradants of butorphanol tartrate using liquid chromatography/mass spectrometry and liquid chromatography/tandem mass spectrometry substructural techniques." *J. Pharm. Biomed. Anal.*, *14*, 1663–1674.
- Volk, K. J.; Hill, S. E.; Kerns, E. H.; Lee, M. S. 1997. "Profiling degradants of paclitaxel using liquid chromatography-mass spectrometry and liquid chromatography-tandem mass spectrometry substructural techniques." *J. Chromatogr. B Biomed. Sci. Appl.*, *696*, 99–115.
- Voyksner, R. D.; Bursey, J. T.; Hines, J. W. 1985. "Analysis of candidate anti-cancer drugs by thermospray high-performance liquid chromatography-mass spectrometry." *J. Chromatogr.*, *323*, 383–394.
- Vrouwe, E. X.; Gysler, J.; Tjaden, U. R.; van der Greef, J. 2000. "Chip-based capillary electrophoresis with an electrodeless nanospray interface." *Rapid Commun. Mass Spectrom.*, *14*, 1682–1688.
- Wagner, D. S.; Markworth, C. J.; Wagner, C. D.; Schoenen, F. J.; Rewerts, C. E.; Kay, B. K.; Geysen, H. M. 1998. "Ration encoding combinatorial libraries with stable isotopes and their utility in pharmaceutical research." *Comb. Chem. High Throughput Screen*, *1*, 143–153.
- Walter, E.; Kissel, T.; Reers, M.; Dickneite, G.; Hoffmann, D.; Stuber, W. 1995. "Transepithelial transport properties of peptidomimetic thrombin inhibitors in monolayers of a human intestinal cell line (Caco-2) and their correlation to in vivo data." *Pharm. Res.*, *12*, 360–365.
- Wang, T.; Zeng, L.; Strader, T.; Burton, L.; Kassel, D. B. 1998. "A new ultra-high throughput method for characterizing combinatorial libraries incorporating a multiple probe autosampler coupled with flow injection mass spectrometry analysis." *Rapid Commun. Mass Spectrom.*, *12*, 1123–1129.
- Wang, T.; Cohen, J.; Kassel, D. B.; Zeng, L. 1999. "A multiple electrospray interface for parallel mass spectrometric analyses of compound libraries." *Comb. Chem. High Throughput Screen*, *2*, 327–334.
- Wang, Z.; Hop, C. E. C. A.; Leung, K. H.; Pang, J. M. 2000. "Determination of in vitro permeability of drug candidates through a Caco-2 cell monolayer by liquid chromatography/tandem mass spectrometry." *J. Mass Spectrom.*, *35*, 71–76.
- Wang-Iverson, D.; Arnold, M. E.; Jemal, M.; Cohen, A. I. 1992. "Determination of SQ 33,600, a phosphinic acid containing HMG CoA reductase

- inhibitor, in human serum by high-performance liquid chromatography combined with ionspray mass spectrometry." *Biol. Mass Spectrom.*, *21*, 189–194.
- Washburn, M. P.; Wolters, D.; Yates, J. R. III. 2001. "Large-scale analysis of the yeast proteome by multidimensional protein identification technology." *Nat. Biotechnol.*, *19*, 242–247.
- Weidolf, L.; Covey, T. R. 1992. "Studies on the metabolism of omeprazole in the rat using liquid chromatography/ionspray mass spectrometry and the isotope cluster technique with [34S]omeprazole." *Rapid Commun. Mass Spectrom.*, *6*, 192–196.
- Weintraub, S. T.; Pinckard, R. N.; Hail, M. 1991. "Electrospray ionization for analysis of platelet-activating factor." *Rapid Commun. Mass Spectrom.*, *5*, 309–311.
- Weller, H. N. 1998–99. "Purification of combinatorial libraries." *Mol. Divers.*, *4*, 47–52.
- Weller, H. N.; Young, M. G.; Michalczyk, S. J.; Reitnauer, G. H.; Cooley, R. S.; Rahn, P. C.; Loyd, D. J.; Fiore, D.; Fischman, S. J. 1997. "High throughput analysis and purification in support of automated parallel synthesis." *Mol. Divers.*, *3*, 61–70.
- Wells, D. A. 1999a. "96-well plate products for solid-phase extraction." *LC-GC*, *17*, 600–610.
- Wells, D. A. 1999b. "Accessory products for SPE using 96-well plates." *LC-GC*, *17*, 808–822.
- White, R. E. 2000. "High-throughput screening in drug metabolism and pharmacokinetic support of drug discovery." *Ann. Rev. Pharmacol. Toxicol.*, *40*, 133–157.
- Whitehouse, C. M.; Dreyer, R. N.; Yamashita, M.; Fenn, J. B. 1985. "Electrospray interface for liquid chromatographs and mass spectrometers." *Anal. Chem.*, *57*, 675–679.
- Whitelegge, J. P.; Gunderson, C. B.; Faull, K. F. 1998. "Electrospray-ionization mass spectrometry of intact intrinsic membrane proteins." *Protein Sci.*, *7*, 1423–1430.
- Whitney, J. L.; Kerns, E. H.; Rourick, R. A.; Hail, M. E.; Volk, K. J.; Fink, S. W.; Lee, M. S. 1998. "Accelerated structure profiling using automated LC-MS and robotics." *Pharm. Tech.*, *May*, 76–82.
- Wieboldt, R.; Campbell, D. A.; Henion, J. 1998. "Quantitative liquid chromatographic-tandem mass spectrometric determination of orlistat in plasma with a quadrupole ion trap." *J. Chromatogr. B Biomed. Sci. Appl.*, *708*, 121–129.
- Williams, A.; Lee, M. S.; Lashin, V. 2001. "An integrated desktop mass spectrometry processing and molecular structure management system." *Spectroscopy*, *16*, 38–49.

- Williamson, B. L.; Tomlinson, A. J.; Mishra, P. K.; Gleich, G. J.; Naylor, S. 1998. "Structural characterization of contaminants found in commercial preparations of melatonin: similarities to case-related compounds from L-tryptophan associated with eosinophilia-myalgia syndrome." *Chem. Res. Toxicol.*, *11*, 234–240.
- Wilm, M.; Mann, M. 1996. "Analytical properties of the nanoelectrospray ion source." *Anal. Chem.*, *68*, 1–8.
- Wilm, M.; Shevchenko, A.; Houthaeve, T.; Breit, S.; Schweigerer, L.; Fotsis, T.; Mann, M. 1996. "Femtomole sequencing of proteins from polyacrylamide gels by nano-electrospray mass spectrometry." *Nature*, *379*, 466–469.
- Wils, P.; Warnery, A.; Phung-Ba, V.; Scherman, D. 1994. "Differentiated intestinal epithelial cell lines as in vitro models for predicting the intestinal absorption of drugs." *Cell Biol. Toxicol.*, *10*, 393–397.
- Wilson-Lingardo, L.; Davis, P. W.; Ecker, D. J.; Hebert, N.; Acevedo, O.; Sprankle, K.; Brennan, T.; Schwarcz, L.; Freier, S. M.; Wyatt, J. R. 1996. "Deconvolution of combinatorial libraries for drug discovery: experimental comparison of pooling strategies." *J. Med. Chem.*, *39*, 2720–2726.
- Wolters, D. A.; Washburn, M. P.; Yates, J. R. III. 2001. "An automated multidimensional protein identification technology for shotgun proteomics." *Anal. Chem.*, *73*, 5683–5690.
- Wong, S. F.; Meng, C. K.; Fenn, J. B. 1988. "Multiple charging in electrospray ionization of poly(ethylene glycols)." *J. Phys. Chem.*, *92*, 546–550.
- Wong, P. S. H.; Yoshioka, K.; Xie, F.; Kissinger, P. T. 1999. "In vivo microdialysis/liquid chromatography/tandem mass spectrometry for the on-line monitoring of melatonin in rat." *Rapid Commun. Mass Spectrom.*, *13*, 1–5.
- Wood, S. A.; Parton, A. H.; Simmonds, R. J.; Stevenson, D. 1996. "Stereoselective metabolism of two keto-pyrrol analogues of 8-hydroxy-2-dipropyl-aminotetralin by freshly isolated rat hepatocytes." *Chirality*, *8*, 264–270.
- Wu, J. T.; Zeng, H.; Deng, Y.; Unger, S. E. 2001. "High-speed liquid chromatography/tandem mass spectrometry using a monolithic column for high-throughput bioanalysis." *Rapid Commun. Mass Spectrom.*, *15*, 1113–1119.
- Wu, S. L.; Wang, Y. J.; Hu, J.; Leung, D. 1997. "The detection of the organic extractables in a biotech product by liquid chromatography on-line with electrospray mass spectrometry." *PDA J. Pharm. Sci. Technol.*, *51*, 229–237.
- Xue, Q.; Foret, F.; Dunayevskiy, Y. M.; Zavracky, P. M.; McGruer, N. E.; Karger, B. L. 1997. "Multichannel microchip electrospray mass spectrometry." *Anal. Chem.*, *69*, 426–430.

- Yates, J. R. 1998a. "Mass spectrometry and the age of the proteome." *J. Mass Spectrom.*, 33, 1–19.
- Yates, J. R. III. 1998b. "Database searching using mass spectrometry data." *Electrophoresis*, 19, 893–900.
- Yates, J. R.; Speicher, S.; Griffin, P. R.; Hunkapiller, T. 1993. "Peptide mass maps: a highly informative approach to protein identification." *Anal. Biochem.*, 214, 397–408.
- Yates, J. R. III; Morgan, S. F.; Gatlin, C. L.; Griffin, P. R.; Eng, J. K. 1998. "Method to compare collision-induced dissociation spectra of peptides: potential for library searching and subtractive analysis." *Anal. Chem.*, 70, 3557–3565.
- Yates, N.; Wislocki, D.; Roberts, A.; Berk, S.; Klatt, T.; Shen, D.-M.; Willoughby, C.; Rosauer, K.; Chapman, K.; Griffin, P. 2001. "Mass spectrometry screening of combinatorial mixtures, correlation of measured and predicted electrospray ionization spectra." *Anal. Chem.*, 73, 2941–2951.
- Yee, S. 1997. "In vitro permeability across Caco-2 cells (colonic) can predict in vivo (small intestinal) absorption in man—fact or myth." *Pharm. Res.* 14, 763–766.
- Yinon, J.; Hwang, D. G. 1985. "Metabolic studies of explosives. II. High-performance liquid chromatography-mass spectrometry of metabolites of 2,4,6-trinitrotoluene." *J. Chromatogr.*, 339, 127–137.
- Yost, R. A.; Boyd, R. K. 1990. "Tandem mass spectrometry: quadrupole and hybrid instruments." *Methods Enzymol.*, 193, 154–200.
- Youngquist, R. S.; Fuentes, G. R.; Lacey, M. P.; Keough, T. 1995. "Generation and screening of combinatorial peptide libraries designed for rapid screening by mass spectrometry." *J. Am. Chem. Soc.*, 117, 3900–3905.
- Yu, X.; Cui, D.; Davis, M. R. 1999. "Identification of in vitro metabolites of indinavir by intelligent automated LC-MS/MS (INTAMS) utilizing triple quadrupole tandem mass spectrometry." *J. Am. Soc. Mass Spectrom.*, 10, 175–183.
- Yuan, C.-H.; Shiea, J. 2001. "Sequential electrospray analysis using sharp-tip channels fabricated on a plastic chip." *Anal. Chem.*, 73, 1080–1083.
- Zavitsanos, A. P.; Alebic-Kolbah, T. 1998. "Enantioselective determination of terazosin in human plasma by normal phase high-performance liquid chromatography-electrospray mass spectrometry." *J. Chromatogr. A*, 794, 45–56.
- Zeedick, J. F. 1979. "A double-blind comparison of oral butorphanol and codeine." *Curr. Med. Res. Opinion*, 6, 178–182.
- Zeng, L.; Kassel, D. B. 1998. "Developments of a fully automated parallel hplc/mass spectrometry system for the analytical characterization and

- preparative purification of combinatorial libraries.” *Anal. Chem.*, 70, 4380–4388.
- Zeng, L.; Wang, X.; Wang, T.; Kassel, D. B. 1998a. “New developments in automated prepLC/MS extends the robustness and utility of the method for compound library analysis and purification.” *Comb. Chem. High Throughput Screen*, 1, 101–111.
- Zeng, L.; Burton, L.; Yung, K.; Shushan, B.; Kassel, D. B. 1998b. “Automated analytical/preparative high-performance liquid chromatography-mass spectrometry system for the rapid characterization and purification of compound libraries.” *J. Chromatogr. A*, 794, 3–13.

INDEX

- Absorption, *see* Pharmacokinetics
Accelerated development strategy
 qualitative process approach, 20–21,
 25–27, 50
 quantitative process approach,
 20–25, 50
Accuracy, 22, 149–150, 154, 163
Accurate mass measurement, 94, 179
Acetophenetidin, 120
Affinity selection, 88
Alprazolam, 112
American society for mass
 spectrometry, 38
Ammonium acetate, 36
Analysis strategies
 automation, 61–63
 databases, 49–50
 integration, 53–55
 miniaturization, 55–56
 parallel processing, 56–57
 screening, 50–53
 standard methods, 43–46
 template structure identification,
 46–49
 visualization, 58–61
Analytical figures of merit, 3, 190
Antibiotics, 84, 142
Anxiolytic drug, 126, 163
Apical side, 119
Area under the plasma concentration
 time curve, 16
Assay validation, *see* Validation
Astemizole, 112
Atmospheric pressure chemical
 ionization, 37, 98–99, 100, 111, 148,
 152
Autoimmune deficiency syndrome, 84
Automation, 23, 42, 61–63, 97, 142, 156,
 184
Auto-Quan, 185
Autosampler, 62, 96–98, 142, 150, 160
Azaspirione decane dione *see*
 Buspirone substructures
Background subtraction, 150
Base peak profile, 71
Basolateral side, 119
Batch processing, 146, 156, 160
Beclomethasone, 112
Benzyl paclitaxel analog, 139
Betamethasone, 112
Bioavailability, 14, 18, 123, 189
Biomolecule analysis, 9, 37, 188
Biotrap column, 164

- Bovine ribonuclease B, 80–82
 Bromazepam, 112
 Bromocriptine, 112
 Bufuralol, 121
 Bulk drug, 123, 141
 Bupropion, 112
 Buspirone, 61, 112, 126–129, 131
 Buspirone glucuronide, 128, 130
 Buspirone substructures, 126–127
 Butoconazol, 112
 Butorphanol, 168–171
 Butylated hydroxytoluene, 176
 Butyl paclitaxel analog, 138
 Butyl piperazine *see* Buspirone substructures

 Caco-2, *see* Human colon adenocarcinoma cell line
 Caffeine, 121
 Calibration curve, 115, 148–150
 Camptothecin, 165
 Capillary electrophoresis, 39
 Capillary ESI interface, 75
 Capillary HPLC, 71
 Carbamazepine, 112
 Cassette-accelerated rapid rat screen, 114–117
 Cassette dosing, 109, 118, 121
 Cefadroxil, 142–143
 Cefadroxil hydrolyzed lactam, 143
 Cefadroxil isomer, 143
 Cefadroxil methyl ester, 143
 Cefadroxil monohydrate, 143
 Cefadroxil sulfoxide isomer, 143
 Cephalosporin, 142
 Chemical ionization, 35
 Chemical manufacture and control, 16, 198
 Chemical stability, 16, 18, 32, 61, 125, 140, 144–146, 169, 171, 188–189
 Chlorpromazine, 120
 Chlorzoxazone, 121
 Cimetidine, 172
 Clemastine, 112
 Clinical development, 12, 16–17, 20, 24, 26, 30, 55, 65–66, 109, 144–148, 156, 160, 165, 169, 184, 190, 198
 Clinical trial application, 12, 15, 22, 24, 123–124, 198
 Clonazepam, 112
 Clonidine, 112
 Clotrimazole, 112
 Clozapine, 152–155
 Collisionally induced dissociation, 51, 78, 109, 198
 Column switching, 54
 Combinatorial analysis, 56–57
 Combinatorial chemistry, 1–3, 9, 22, 31, 58, 63, 68, 88–89, 92, 103, 106, 118, 123, 187, 191, 193, 198
 Combinatorial libraries, 88, 92, 94–94, 100, 105, 187, 198
 Combinatorial mixture screening, 103
 Comparative maps, 79, 81–82, 188
 Contract research organizations, 190
 Correlation analysis, 189
 Cortisone, 112
 Cost-effectiveness, 53
 Cost profile, 29
 Coumarin, 121
 Cytochrome P450 isozymes, 121

 D₃-N-ethyldecylamine, 94
 D₃-N-ethylheptylamine, 94
 D₃-N-ethylhexylamine, 94
 D₃-N-ethylnonylamine, 94
 D₃-N-ethyloctylamine, 94
 D₃-N-ethylpentylamine, 94
 Danazol, 112
 Dansyl chloride, 94
 Dapsone, 121
 Database mining, 49
 Databases
 automation, 62
 buspirone metabolites, 128–131
 butorphanol degradants, 170
 cefadroxil degradants and impurities, 143
 clinical development, 145–146
 combinatorial library screening, 92
 CPT-11 metabolites, 166–167
 degradant identification, 140–142, 169
 drug discovery, 14
 emerging needs, 2

- information management, 189
- impurity identification, 138–140
- integration into drug development, 6
- manufacturing, 17
- metabolite identification, 127–132
- natural products dereplication, 84
- pharmacokinetics, 115
- preclinical development, 124–125
- proteomics, 70–73, 77
- strategies, 41–42, 49–50
- TAXOL[®] impurities, 138–139
- Database searching, 70–73, 92
- Data dependent software, 62, 172–176, 186
- Data management, 23, 68, 100, 133, 148, 189, 195
- Data processing, 23, 105, 156
- Debenzoyl pentenoate paclitaxel analog, 138
- Debenzoyl-10-deacetyl baccatin III pentenoate, 139
- Debenzoyl-10-deacetyl baccatin III phenylacetate, 139
- Debrisoquin, 121
- Degradants
 - butorphanol, 168–171
 - cefadroxil, 140–145
 - clinical development, 145–148
 - integration, 55
 - manufacturing, 18, 171, 176
 - miniaturization, 188–189
 - parallel processing, 57
 - preclinical development, 15, 123–125
 - screening, 51
 - TAXOL[®], 48
 - template structure identification, 47
- Δ^2 -cefadroxil isomer, 143
- $\Delta 1,10a$ butorphanol, 169
- Dereplication, 49, 68, 83–88, 92, 132–133, 140, 198
- Desorption chemical ionization, 3
- Despyrimidinyl buspirone, 129, 131
- Despyrimidinyl piperazine buspirone, 129, 131
- Didecylamine, 94
- Diethylene glycol, 175
- Diheptylamine, 94
- Dihydroxy buspirone, 129–131
- Dihydroxy methoxy buspirone, 129, 131
- Diltiazem, 112
- Diocetylamine, 94
- Diphenhydramine, 120
- Direct injection *see* Flow injection analysis
- Direct liquid introduction interface, 5
- Dissolution, 145
- Distribution, *see* Pharmacokinetics
- Dose, 16–17
- Dosage form, 16, 187
- Drug development
 - accelerated, 19, 33
 - bottleneck, 10, 33, 58, 83, 103, 160, 185, 191
 - clinical development, 13, 16–17
 - drug discovery, 1, 11–15, 22, 24, 43, 47, 50–51, 65–68, 83, 89, 97, 106, 109–114, 122–123, 132, 145, 183, 186
 - four stages, 12–13, 66
 - manufacturing, 12–18, 55, 63, 66, 141, 145, 171–179, 183
 - overview, 11, 66
 - preclinical development, 12–16, 46, 49, 54–55, 65–67, 123–126, 132–133, 140, 145, 152, 169, 172, 183
 - projections, 15
 - strategies, 20
- Drug design, 67
- Drug discovery, 12, 14–15, 65–69, 198
- Drug-drug interaction, 114, 121–122
- Drug formulation, 141, 145
- Drug product packaging, 172
- Drug-protein binding, 51–52
- Drug substance, 16, 172, 179, 199
- Econazole, 112
- Efficiency, 3, 6, 9, 22, 25–28, 32, 39, 42, 56, 111, 123, 147, 192–194
 - 80/20 rule, *see* Pareto's law
- Electron ionization, 35
- Electrospray ionization, 5, 35, 37, 53, 71, 74–76, 84–85, 92, 97, 99–100, 104–105, 173, 199
- Elemental analysis, 37
- Encoded combinatorial synthesis, 93
- Encoding methodologies, 88

- Enzymatic digest, 81
Estazolam, 112
Ethyl paclitaxel analog, 138
Exact mass measurement, 36, 92, 95, 186
Extraction efficiency, 114, 149
Excretion, *see* Pharmacokinetics
Extracted ion current profile, 58, 143, 151, 179, 199
- Famotidine, 112
Fast atom bombardment, 35
Fast chromatography, 50, 100
Felodipine, 112
Fenfluramine, 112
Figures of merit, 3, 5, 53, 190
Flow injection analysis, 103–104, 122
Fluconazole, 112, 120
Flunitrazepam, 112
Fluorescence detection, 152, 157
Fluoxetine, 112
Follow-on clinical studies, 18
Food and drug administration, 13, 173, 176, 199
4-hydroxymephenytoin, 121
4-hydroxytolbutamide, 121
Fourier transform ion cyclotron resonance mass spectrometry, 75, 92, 95, 199
Fraction collection, 53, 84–85, 103
FRAGFIT, 73–74
Fragmentation map, 88
Full-time equivalent, 15, 28–29, 190, 199
- Gas chromatography/mass spectrometry, 7, 64, 98, 148, 199
Generic methods, *see* Standard methods
Genomics, 3, 191, 200
Glycoprotein characterization, 79–80
Good laboratory practice, 13, 146, 200
Good manufacturing practice, 13, 146, 200
Gradient chromatography methods, 43, 75, 85, 95, 102, 115, 118, 173
Guanfacine, 112
Guard column, 86, 119
- Haloperidol, 112, 120
Heterogeneity
 glycoforms, 80–81, 83, 186
Hexyl paclitaxel analog, 139
High performance liquid chromatography
 automation, 62
 clinical development, 145, 147–148
 combinatorial library screening, 93–95
 combinatorial mixture screening, 103
 elements of LC/MS application, 34–36
 high throughput, 100
 impurity identification, 134, 140, 173
 integration, 5, 53
 lead identification screening, 88
 LC/MS growth, 39
 manufacturing, 171
 metabolic stability screening, 118
 miniaturization, 55
 multidimensional analysis, 186
 natural products dereplication, 84–85
 parallel processing, 56
 partnership and acceptance, 7
 patent protection, 179
 pharmacology, 112, 115
 preclinical development, 123–124
 protein expression profiling, 71–73
 purification, 102
 quantitative bioanalysis, 150, 152, 156–157, 163
 screening, 51
 standard methods, 43
 structure confirmation, 99
Homoleobandidine, 88
Human colon adenocarcinoma cell line, 119–120
Human immunodeficiency virus, 122
Human liver microsomes, 118, 122
Hydroxy buspirone, 129, 131
Hydroxy buspirone glucuronide, 128, 130
Hydroxy methoxy buspirone glucuronide, 128, 130
Hydroxy-10-deacetyl baccatin III, 139
Hypothetical drug development pipeline, 22, 24, 27, 32

- Imipramine, 120
 Impurity identification, 15, 47, 49, 51,
 55, 123–125, 132–140, 145–147, 152,
 169, 176, 179–182
 Indapamide, 113
 Indinavir, 122
 Indomethacin, 113
 Indoprofen, 113
 Informatics, 105, 189–190
 Infrared, 37, 96, 99, 191
 In process analyses, 63, 97, 141
 Internal standard, 111, 122, 148–150,
 153–154, 157, 160
 Investigational new drug, 12, 15, 24,
 123–124, 200
 In vitro drug screening, 115–118
 In vivo drug screening, 106–115
 Ion current, 51, 56, 104, 126
 Ion trap mass spectrometer, 39, 54, 75,
 88, 122, 145, 165, 173–174, 179, 188,
 200
 Isocratic HPLC method, 56, 112
 Isotope-coded affinity tag, 76–77
 Itraconazole, 113

 Ketoconazol, 113, 120
 Ketorolac, 113

 Lasso tool, 59
 Leachables, 172–173
 Lead candidate, 1, 11–14, 19–20, 22,
 24, 26, 33, 54, 67, 118, 123, 132,
 141
 Lead compound, 14, 22–25, 33, 54,
 67, 92, 106, 108–109, 111, 123,
 145
 Lead identification, 14, 23, 67, 88–96
 Lead optimization, 14, 43, 54, 56, 67,
 200
 Lib View, 105, 107
 Lidocain, 113
 Lidoflazine, 113
 Limit of detection, 51, 114, 152, 163,
 200
 Limit of quantification, *see* Lower limit
 of quantitation
 Linear dynamic range, 149
 Lipophilicity screening, 56, 201

 Liquid chromatography/mass
 spectrometry, 3
 analysis strategies, 41–64
 application elements, 34–37
 clinical development applications,
 148
 drug discovery applications, 69
 growth, 38–40
 industry acceptance, 5–6
 ionization, 36
 manufacturing, 172
 preclinical development applications,
 125
 seven stages, 7–9
 Liquid chromatography/nuclear
 magnetic resonance, 39, 187
 Liquid-liquid extraction, 148
 Lisinopril, 113
 Long-term stability studies, 18,
 145–147, 168–170
 Loperamide, 113
 Lorazepam, 113
 Lormetazepam, 113
 Lower limit of quantitation, 119, 152,
 154, 157, 163, 201

 Manufacturing, 12, 171–172, 201
 Marker metabolites, 122
 Marketing authorization application,
 12, 16–17, 20, 24, 26, 30, 55, 65–66,
 109, 144–148, 156, 160, 165, 169,
 184, 190, 201
 MASCOT, 73
 Mass accuracy, *see* Accurate mass
 measurement
 Mass chromatograms, *see* Extracted ion
 current profile
 Mass spectrometers
 ion trap, 39, 200
 magnetic sector, 39
 quadrupole time-of-flight mass
 spectrometer, 75, 92, 179–180, 182,
 186, 203
 single quadrupole, 39, 111, 203
 tandem quadrupole mass
 spectrometer, 39, 71, 73, 85, 122,
 165, 178, 188, 204
 time-of-flight, 39, 75, 100, 204

- Mass spectrometry, 5, 35–36
- Matrix-assisted laser desorption/ionization, 39, 70, 76–77, 85, 201
- Maximum concentration at steady state, 16
- Maximum tolerated dose, 165
- Medazepam, 113
- Memory effect, 99, 112
- Mephenytoin, 121
- Metabolic stability, 20, 54, 61, 106, 119
- Metabolism, *see* Pharmacokinetics
- Metabolism-guided structural modification, 122
- Metabolite identification, 46, 122, 125, 157, 165
- Metabolite structure, 49, 58, 126–127, 132
- Method development, 43, 46, 50, 63, 104, 109, 122, 124–125, 140, 145–147, 184, 193
- Methoxy buspirone glucuronide, 129, 131
- Methyl paclitaxel analog, 138
- Miconazol, 113
- Microcolumn HPLC, 74, 93
- Microelectrospray, *see* Nanoelectrospray
- Microheterogeneity, *see* Heterogeneity
- Microsomes, 51
- Midazolam, 113, 121
- Miniaturization, 55–56
- Models
- elimination, 29–31
 - rate-determining event, 31–32
 - sample throughput, 29
- Molecular connectivity, 47, 126
- Molecular formula, 36, 95, 182
- Molecular weight, 20, 35–36, 46–47, 49, 53, 67, 71, 79, 84–85, 90, 93–94, 108, 124, 126, 133–134, 140, 142–144, 148, 169, 173–174, 177
- Moving belt interface, 5
- MudPIT, 77
- Multidimensional analysis, 186–187
- Multidimensional chromatography, 186
- Multiple reaction monitoring, 119, 122
- Multiplexed electrospray ionization interface, 100–101
- n-in-one methodology, 109, 111–114
- n-propyl-epi-paclitaxel analog, 139
- n-propyl paclitaxel analog, 138
- Naltrexone, 113
- Nanoelectrospray, 37, 56, 75, 188
- Natural products, 3, 9, 14, 37, 49, 53, 67, 83–88
- Neutral loss scan mode, 53, 201
- New chemical entity, 27, 201
- New drug application, 12, 24–25, 30, 146–147, 171, 201
- Nicardipine, 113
- Nifedipine, 113
- 9-hydroxy-butorphanol, 169
- 9-keto-butorphanol, 169
- 96-well sample plates, 55, 58, 104, 115, 156, 160–162, 187
- Nimodipine, 113
- Nitrendipine, 113
- Nitrazepam, 113
- N-acetylhexosamine, 78
- N-heptyldodecylamine, 94
- N-heptyloctylamine, 94
- N-hexyldodecylamine, 94
- N-linked glycoprotein, 52, 78
- N-pentyloctylamine, 94
- N-pentyldodecylamine, 94
- Nizatidine, 113
- Norbutorphanol, 169
- Nuclear magnetic resonance, 4, 23, 37, 39, 47, 53, 96, 99, 132, 178, 187, 191, 202
- O-linked glycoprotein, 52, 78
- Ofloxacin, 113
- Omeprazole, 113
- On-line extraction, 54, 147, 162–165
- 1-hydroxybufuralol, 121
- 1-hydroxymidazolam, 121
- 1-pyrimidinyl piperazine, 128, 130
- Open-access, 9, 39, 63, 68, 96–105, 193
- Orphenadrine, 120
- Outsourcing, 9, 18, 190–191
- Oxazepam, 113
- Oxybutinine, 113

- Paclitaxel, *see* TAXOL®
- Paclitaxel side chain methyl ester, 138
- Paracetamol, 121
- Parallel compound synthesis, 56, 102
- Parallel processing, 56–57, 161, 188, 202
- Parent drug, 47, 119, 124, 126, 146, 180, 182
- Pareto's law, 46, 109
- Paroxetine, 113
- Particle beam interface, 98
- Patents
 - process, 18
 - protection, 171, 178–182
- Peak parking, 75
- Penfluridol, 113
- Pentazocine, 113
- Peptide analysis, 97
- Peptide mapping, 176–178
- Peptide N:glycosidase F, 78–80
- Peptide quantitation, 77
- Perfusive chromatography, 90, 202
- Peroxisome proliferators-activated receptor, 89–90
- Personal computer, 98
- Pharmaceutical properties
 - information collection, 50
 - lead candidate, 14
 - prediction, 2
 - relative order, 23
 - ranking, 23
 - screening, 50–51
 - visualization, 58, 61
- Pharmacokinetics, 7, 9, 16–17, 22, 31, 61, 68, 106, 109–115, 119, 146–148, 156, 165, 197, 202
- Pharmacokinetics screening, 54
- Phenacetin, 121
- Phenelfamycin, 87
- Phytoestrogens, 53
- Piperazinedione cefadroxil isomer, 143
- Pittsburgh cocktail, 121
- Placebo, 17, 202
- Plasma concentration-time profiles, 110
- Polygonum facidum*, 88
- Pooled plasma, 108
- Post-translational modification, 77, 172, 187
- Prazepam, 113
- Preclinical development, 12, 16, 46, 49, 54–55, 65, 67, 123–125, 141, 152, 172, 183, 202
- Precision, 108, 150, 154, 163
- Precursor ion scan mode, 52, 202
- Predictive models
 - in vitro, 20, 51, 122, 141–144, 187–188
 - in vivo, 20
- Preparative LC/MS, 103
- Product ion scan mode, 52, 202
- Productivity, 22, 26
- Profile groups, 126, 137
- Projections
 - maximum development times, 14–15
 - minimum development times, 14–15
- Propafenone, 113, 120
- Protein binding, 111
- Protein characterization, 71
- Protein expression profiling, 70–76
- Proteomics, 1, 31, 49, 68–77, 123, 191, 202
- Pulsed ultrafiltration, 88
- Purification
 - impurity identification, 133
 - natural products dereplication, 84
 - open-access, 97, 102–103
 - proteomics, 73, 76
 - strategy, 63
 - workstations, 185
- Purity, 18, 36
- Pyrimidine *see* Buspirone substructures
- Quadrupole time-of-flight mass spectrometer, 75, 92, 179–180, 182, 186, 203
- Qualitative process pipeline model, 26
- Quality control, 18, 157, 172, 176, 184
- Quantitation
 - automated on-line extraction, 162, 165
 - automated solid phase extraction, 156–162
 - bioaffinity screening, 90
 - drug-drug interaction, 122
 - high throughput, 39
 - LC/MS interface, 36
 - manufacturing, 171–172
 - proteins, 70, 76–77

- screening, 50
- selected ion monitoring, 148–151
- selected reaction monitoring, 152–156
- workstations, 184
- Quantitative process pipeline model, 24
- Radiolabeling, 37
- Ranitidine, 113
- Rational drug design, *see* Drug design
- Rat liver slices, 53
- Reaction monitoring, 39
- Receptor-ligand interaction, 37
- Reconstructed ion current, 78, 103
- Reference standards, 172
- Relative retention time, 124, 169, 177
- Research and development, 33
- Restricted access media, 163
- Retention time, 20, 46–47, 49, 53, 85, 119, 123–124, 133–134, 140, 142, 169, 177, 179
- Robotics, 61, 112, 157, 183–184
- Sample analysis activity, 28
- Sample-generating activity, 28
- Sample preparation, 23, 109, 146, 148–149, 156–157, 160, 163–165
- Sample type
 - nontrace/pure, 3, 4
 - pharmaceutical, 3
 - trace mixture, 3, 4
- Scale-down models, 55, 188
- Screening, 50–53
- Selected ion monitoring, 51, 118, 147–148, 150, 152, 203
- Selected reaction monitoring, 109, 147, 152–155, 157–160, 203
- Selectivity, 53, 108, 172
- Sensitivity, 53, 146, 172, 203
- Separation sciences, 5
- SEQUEST, 73, 145
- Serial analysis, 57
- 7-*epi*-butyl paclitaxel analog, 139
- 7-*epi*-cefadroxil, 143
- 7-*epi*-cephalomannine, 139
- 7-*epi*-taxol C, 139
- 7-ethyl-camptothecin, 165
- 7-hydroxycoumarin, 121
- 7-xylosyl benzyl paclitaxel analog, 138
- 7-xylosyl-10-deacetyl benzyl paclitaxel analog, 138
- 7-xylosyl-10-deacetyl hexyl paclitaxel analog, 138
- Signal-to-noise ratio, 75
- Single quadrupole mass spectrometer, 39, 111, 165, 203
- 6-hydroxychlorzoxazone, 121
- Size exclusion chromatography, 89, 92
- Sodium dodecyl sulphate-polyacrylamide gel electrophoresis, 70
- Soft spots, 58, 122, 203
- Solid-phase extraction, 56, 112, 147, 156–162, 203
- Somidobove, 177–179
- Specifications, 14, 17–18, 62, 124–125, 171, 177, 186
- Speed, 53
- Spin column, 90
- Spironolactone, 113
- Stadol, *see* Butorphanol
- Standard curve, *see* Calibration curve
- Standard methods, 9, 43–46, 50, 61–62, 81, 98, 108, 115, 118, 122, 124, 126, 133, 140, 142, 146, 150, 152, 157
- Standard operating procedures, 17, 111, 203
- Structure analysis matrix, 4
- Substructure analysis, 52, 181, 203
- Sulfaphenazole, 120
- Tandem mass spectrometry, 36, 46, 92, 109, 140
- Tandem quadrupole mass spectrometer, 39, 71, 73, 85, 122, 165, 178, 188, 204
- TAXOL[®], 18, 47–48, 132–140
- Taxus baccata, 132
- Taxus brevifolia, 132, 134–137
- Technology transfer, 19
- Temazepam, 113
- Template structure identification, 41–42, 46–50, 52, 73, 100, 115, 124, 132–133, 140, 142, 152, 153, 165, 177, 182

- 10-deacetyl baccatin III
 - hydroxybutyrate, 139
- 10-deacetyl benzyl paclitaxel analog, 138
- 10-deacetyl ethyl paclitaxel, 139
- 10-deacetyl propyl paclitaxel analog, 138
- 10-deacetyl-7-epi-celphalomannine, 138
- 10-deacetyl-7-epi-taxol C, 138
- 10-deacetyl taxol C, 138
- Terconazol, 113
- Terfenadine, 113
- Testosterone, 120
- Thermospray ionization, 5, 36–37, 53, 98, 204
- Thin layer chromatography, 99, 204
- Time-of-flight mass spectrometer, 39, 70–71, 75–76, 85, 92–94, 100, 188, 204
- Tolbutamide, 120–121
- Topoisomerase II, 165
- Total ion current, 71, 204
- Toxicity, 14–15, 22, 122, 125, 140, 145, 165, 173
- Toxicology, 16, 124, 184
- Trace-mixture analysis, 3–4, 37, 39, 126, 185
- Triple quadrupole mass spectrometer,
see quadrupole mass spectrometer
- 2-Dimensional gel electrophoresis, 70
- 2-isophthalic acid, 176
- Ultraviolet absorption, 84
- Ultraviolet chromatogram, 169
- Ultraviolet detection, 36, 133, 173
- Validated methods, 124, 173
- Validation, 7, 16, 43, 62
- Visual Basic, 104
- Visualization, 3, 41–42, 58–61, 71, 105, 190
- WebServer, 105
- Windows NT, 98
- Workstations, 2, 109, 183–185, 190
- Yohimbine, 104
- Zopiclone, 113