

Eric Bruton

The Longcase Clock



Second Edition

The Longcase Clock is the standard work on the origins and history of the grandfather clock, for collectors and enthusiasts.

For the second edition the book has been substantially expanded and the format enlarged. It now includes over a hundred new photographs of longcase clocks and their movements and dials, from the earliest seventeenth-century pendulum clocks to 8-day and 30-hour clocks ; English, European and American. A new chapter has been added on the 30-hour clock (now very significant to collectors) and provincial clocks, which have also increased in value in the last decade ; and a new chapter is included on American and European longcase clocks. In addition there are several new drawings of the inner workings and designs of standard clocks.

As before, Mr. Bruton discusses the clock's origins ; how it became really accurate ; its movement ; cases, hands and dials ; famous and obscure makers ; the heyday of the grandfather clock ; precision clocks ; and finally the grandfather clock of today and how to look after it. Again there is a selective bibliography and a guide to grandfather clocks.

Illustrated

THE
LONGCASE
CLOCK

WITHDRAWN

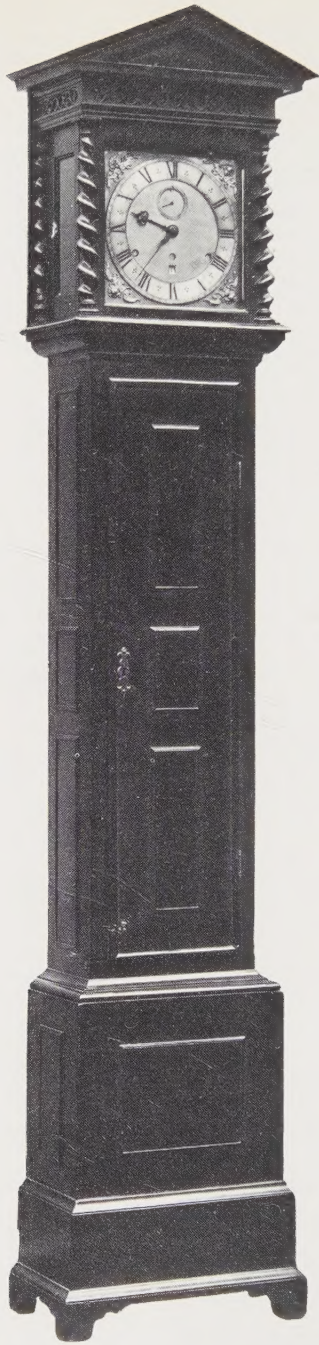

Plate 1



THE
LONGCASE
CLOCK

ERIC BRUTON

Charles Scribner's Sons · New York

681
B
1977

Copyright © Eric Bruton 1964 and 1977

All rights reserved. No part of this publication may be reproduced, stored in a retrieval system, or transmitted, in any form or by any means, electronic, mechanical, photocopying, recording or otherwise, without the prior permission of the publisher. Copyright under the Berne Convention.

1 3 5 7 9 11 13 15 17 19 I/C 20 18 16 14 12 10 8 6 4 2

Printed in Great Britain
Library of Congress Catalog Card Number 79-
ISBN 0-684-16247-4



CONTENTS

<i>Acknowledgements for plates</i>	6
<i>Preface to First Edition</i>	7
<i>Preface to Second Edition</i>	9
1 The Birth of the Pendulum Clock	12
2 The First Pendulum Clock	24
3 Development of the Longcase Clock	34
4 Timekeeping, Striking and Chiming	44
5 Shapes and Wood for Cases	58
6 Dials and Hands	78
7 Moon Dials, Calendars and other Special Indications	104
8 Thirty-hour and One-hand Clocks	120
9 Development of the Regulator	138
10 Special Clocks to Cottage Clocks	150
11 The Famous Makers	166
12 An Ancient Workshop and Restoration Today	188
13 European Longcase Clocks	204
14 North American Clocks and Makers	208
15 Valuing and Setting-up a Clock	224
<i>Appendix I: Pendulum Calculations</i>	234
<i>Appendix II: Dating by General Style</i>	236
<i>Bibliography</i>	238
<i>Index</i>	240



ACKNOWLEDGEMENTS FOR PLATES

The photographs in this book are reproduced by kind permission of the following. Plate 17 by the gracious permission of Her Majesty the Queen; Plates 125 and 145, Biggs of Maidenhead; Plates 36, 89, 90, 96, 99, and 122, Christie's; Plate 26a, Coles, Knapp and Kennedy; Plate 138, J. E. Coleman; Plate 97, Paul Frank; Plate 4, Frederiksborg Castle, Denmark; Plate 34, Graves, Son and Pitcher; Plates 69, 130, 134, and 136, Greenwich Village and the Henry Ford Museum, Michigan; Plate 124, J. P. Hagnauer, Paris; Plate 46, W. R. Harvey & Co. (Antiques) Ltd.; Plates 128, 129, 131, 132, 137, and 140, Historical Society of Pennsylvania; Plate 88, G. E. Hutchinson; Plates 119, 120, and 121, *Illustrated London News*; Plates 32 and 70, Lawrence of Crewkerne; Plates 39, 47, 49, 57, 59, 60, 61, 62, 74, 79, 80, 81, 83, and 98, Brian Loomes; Plate 93, *Manchester Guardian*; Plates 2, 3, 19, 29, 31, 37, 48, 51, 56, 71, 73, 75, and 82, Bernard Mason Collection; Plate 133, Jay T. Mills; Plate 55, C. Morrison; Plate 65, Pelham Galleries; Plate 135, Yale University Art Gallery, Garvan College; Plate 139, The Shaker Museum; Plate 16, 25, 76, 77, 78, 91, 101, and 123, Sotheby and Co.; Plate 38, F. E. Stephens; Plates 94 and 95, Philip P. Thornton; Plates 42 and 102, M. V. Tooley.



PREFACE
TO
FIRST EDITION

The longcase clock, made from 1660 to the nineteenth century, has a special place in the histories of timekeeping and domestic furniture. It was the first really accurate domestic clock. Even today a clock over 200 years old can give a good account of itself against the radio time signals. For many years it has been largely eclipsed by fashion, but today it is very much in favour again – as reflected by the prices of over £10,000 paid for special seveneenth-century clocks and around £50 for ‘cottage’ clocks that could be bought for £5 ten or so years ago.

The longcase clock – also called the ‘coffin clock’ and ‘tall clock’ after its shape, and later the ‘grandfather clock’ after a popular song written in 1876 – is also noteworthy for being an entirely English invention.

I meet many engineers in many fields of endeavour and it is always astonishing to find how many are ignorant of the operation of timepieces, although horology – the science of timekeeping – was one of man’s first mechanical arts, certainly his first precision engineering. The artistic merit of antique clocks and watches was better understood although even that appreciation was delayed for a long time.

This book is not intended to present any new research or theories; its purpose is to help the small collector and to spread more knowledge and understanding of the longcase clock among laymen. Many books about clocks concentrate only on the very ‘best’ from the horological or aesthetic point of view. Here I have tried to describe ordinary as well as special pieces, for the

'ordinary' longcase clock even of the nineteenth century, a despised period, was still a remarkably fine production compared with some of today's stamped-out tickers.

I would like to thank my friends Philip Coole of the British Museum, and Bernard Royer-Collard, the horological antique dealer, for reading the manuscript and making many valuable suggestions. Any errors that remain are mine, not theirs.

Great Bookham, Surrey

ERIC BRUTON



PREFACE
TO
SECOND EDITION

As the first edition of this book was well received in its British and American reprints, it was thought worthwhile to present a revised edition with more and different illustrations and with two new chapters. Most clocks that have to be wound daily were not considered of great importance when the first edition was written. Quite rightly, they have now taken their true place in the history of the grandfather clock and are provided with a chapter to themselves.

More emphasis has been placed on clocks made outside London and on the colourful painted dial, referred to in earlier centuries as the 'white dial', again because the general interest has broadened.

The other new chapter is about the North American tall clock which, more than the productions of any other country, fit into the pattern of development of the English grandfather clock.

Many detailed changes and additions have been made throughout the text, but the objective remains as before, to interest and help the layman. For the same reason, technical matter has been kept to a minimum. The many cross references to plates in the text are for those needing specific information, and can be ignored by the general reader. Readers whose interest is permanently aroused should join one or both of the antiquarian societies whose addresses are given on the last page of the text.

The biggest change since the original book was published has been in prices. The cottage clocks referred to as being as much as £50 are £300 and more today and still going up because inflation

is at work on values as well as there being a greater appreciation of and demand for the work of past craftsmen.

I have many people to thank most sincerely for their help and encouragement. First of all a friend of many years, Colonel Humphrey Quill, past Master of the Worshipful Company of Clockmakers, who has done so much to aid research and preserve records of the past through the Company's collection and to provide practical assistance to those aspiring to be fine horological craftsmen of the future. Then there is Beresford Hutchinson, who succeeded the late (alas) Philip Coole at the British Museum and is a worthy successor in every way. Brian Loomes, the Yorkshire genealogist and clock dealer, has been especially generous with information and comment as well as with pictures. The Colchester collector Bernard Mason also responded generously and at once to my plea for some prints of his clocks. The big London auction rooms, as always, have been especially helpful. Both Sotheby and Co. and Christie's went to much trouble to provide pictures when I asked for them.

For American pictures I am much indebted to Robert G. Wheeler, vice-president of the Greenwich Village and Henry Ford Museum, the Library Company of Philadelphia, James E. Mooney, assistant director of the Historical Society of Pennsylvania, the Shaker Museum, Jay T. Mills of Trenton, New Jersey, Mrs Shepard Roberts of Scotia, New York, and another old friend, J. E. Coleman of Tennessee, who died, sadly, as this book was going to press.

Widmer End, Buckinghamshire

ERIC BRUTON

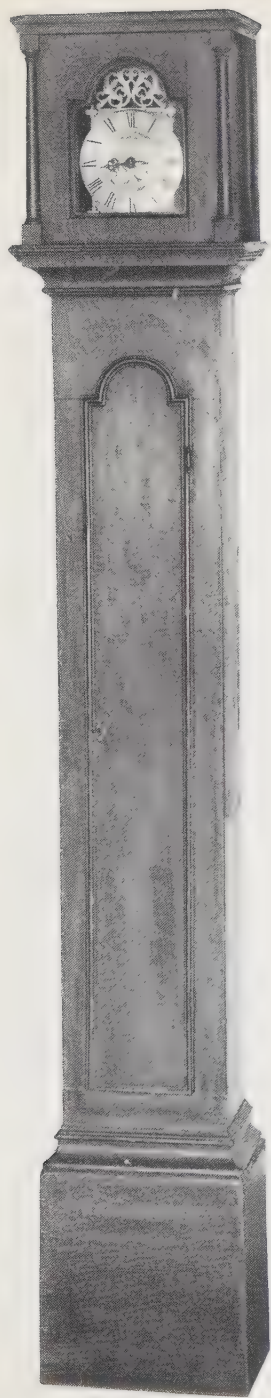

Plate 2 A lantern clock was sometimes used in a long case instead of being hung on the wall or stood on a wall bracket. This pine case is contemporary with the clock, made by John Smorthwait of Colchester in the early eighteenth century.



THE
BIRTH
OF THE
PENDULUM CLOCK

OPPOSITE

Plate 3 The hood of the clock shown in *Plate 2* has been removed to show the lantern clock inside.

To understand how the longcase clock came into being, it is necessary to start the story a few years before it appeared. A convenient time is when Oliver Cromwell, at the head of his armies of Roundheads, had triumphed over King Charles II at Worcester, causing him to fly to France. At this time, around 1650, there were some large iron public clocks with 'birdcage' frames several feet across made by clockmaker-blacksmiths in churches and church and town hall towers. Only the wealthier families had domestic clocks.

The domestic clock might have been one of the latest spring-driven table clocks from Nuremberg or Augsburg in Germany, or an old iron chamber clock from the same source. More likely, it was a lantern clock. The lantern clock was the first true English clock distinguishable from those made on the continent. It was known at the time as 'a brass clock' – to distinguish it from the French and German clocks of iron with painted dials – and was made in large numbers between about 1600 and 1660. None of these was controlled by a pendulum.

The name 'lantern' is a corruption of *latten*, from *laton* or *laiton*, Old French for brass, or the clock was so named because its box shape with a domed bell on top was reminiscent of an old horn lantern in appearance (see Plates 2 and 3). The main frame had four brass corner posts – like bed-posts – with brass doors, the movement inside being of brass and iron, driven by weights. The exposed dial of engraved brass had one stubby iron hand to point to the hours and usually a small dial in the centre to set the alarm.

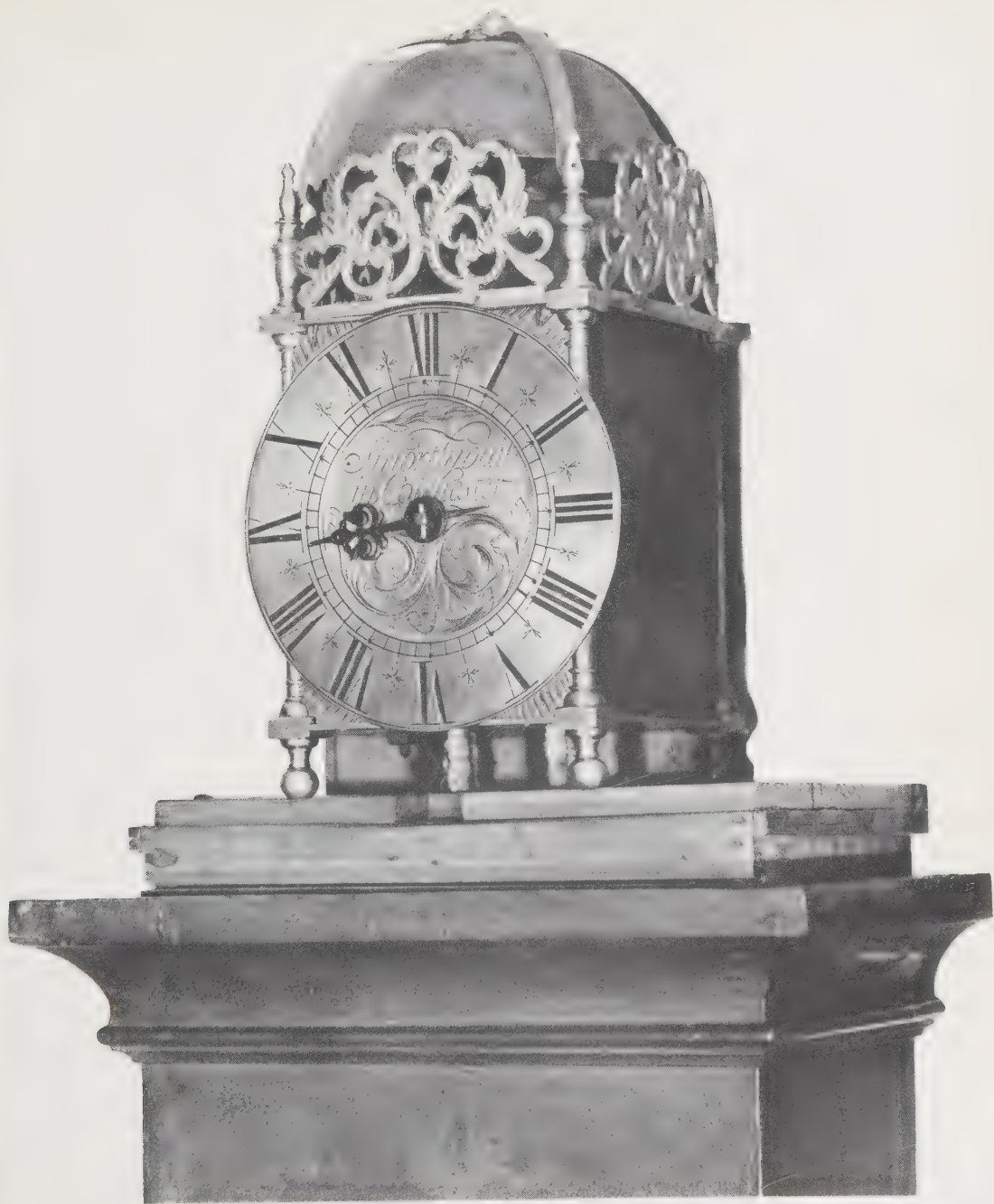

A stirrup at the back of the clock near the top enabled it to be hung from a hook in a wall, probably in the central hall of the house so that its striking could be heard in the rooms around. Two iron spurs projecting from the bottom of the clock at the back kept it parallel to the wall so that the weights would hang clear. Their sharp points, sticking into the wall surface, also prevented accidental movement of the clock. Winding would have been necessary twice a day, otherwise the weight driving the timekeeping part of the clock would come to rest on the floor and the clock would stop.

A clock owner had to check its time every few days by a sundial in the garden, on the side of the house or at a near-by church, because there was no time service of any kind and his clock could easily drift to an hour or so fast or slow.

While the clock had some domain over the routine of the Jacobean manor house, it had no influence on the people working in the fields. Their clock was the sun itself. They rose when the sun rose and went to bed when it set. The sun marked the days for them and broad divisions of the days. Their eating times were controlled by another natural timekeeper that has only been studied in quite recent years – the ‘human clock’. Every human and animal organism has a ‘built-in’ clock that works to a twenty-four hour time-table and can be stopped and restarted – as when a man is unconscious – and can be reset, but cannot be set to run at a substantially different rate. One more clock, the moon, marked the months and seasons, provided light for those who wished to venture out at night, and gave some indication of the ebb and flow of tides in the sea and rivers, which were very important for transport.

All these phenomena were ‘natural clocks’. The ‘artificial clock’, as the mechanical clock was sometimes called in its early days, was an attempt to copy the movement of the sun. On a sunny day the position of the sun in the sky indicated the time; on cloudy days and at night it was impossible to see the sun. So a mechanical contrivance was made to indicate where the sun was. That was the clock. In this country the day was divided into two series of twelve hours, so the hour hand turned twice while the sun ‘went round the earth’ once. In some other countries of earlier times the day was divided into twenty-four hours, so the hand of the clock turned with the sun; if the clock hand were pointed at



Plate 4 Astronomers were concerned with making working models of the universe which had to be driven by a clock. This Copernican system was made in *c.* 1651, before the pendulum, for the Duke of Gottorp and is in Frederiksborg Castle, Denmark.

OPPOSITE

Fig. 1 How the lantern clock movement with balance was converted to pendulum clock by making the verge and crown-wheel horizontal. The very first longcase clocks had a short pendulum movement similar to that in the centre. On the right is a conversion from balance-wheel to long pendulum with anchor escapement.

the sun, it would follow it across the sky. We all know today that it is the revolving earth that makes the sun appear to go round it, but that makes no difference to the principle.

The domestic clock did not come into being from a single inspiration or from the labour of one man, or even one nation. The men first concerned with accurate measurement of time were astronomers, for the observation of the movement of heavenly bodies requires precise timekeeping. To develop, understand, and explain theories about the movements of the sun, earth, and moon, and the 'Celestial Spheres', they made working models (see Plate 4). It was an obvious next step to make some of these models automatic, to attempt to rotate a model globe in twenty-four hours as the earth turns or to make moving star maps (see Plate 5).

As early as the year 1100, a Chinese astronomer named Su Sung had constructed a great pagoda clock thirty-six feet high that operated astronomical models, one of which showed star positions. Processions of puppets carried tablets showing the time of day to sightseers outside. The astronomical models were inside, for serious study. The clock was driven by water from tanks which turned a huge water-wheel. Most important of all it contained a device to control the rate at which the water-wheel was turned. This is known as the 'escapement' and is a vital part of any timekeeper.

The escapement is the pulse of a clock. As its name suggests, it lets the power driving the clock 'escape' in tiny, exact amounts so that the clock hand moves in tiny steps at an even and controlled rate. Su Sung's clock is the earliest containing an escapement of which details are known. The escapement may have been invented some centuries earlier by a monk named I'Sing.

Astronomers through the centuries continued to make – or rather have made for them – elaborate models showing different theories of the universe, according to Ptolemy, Copernicus, and others. By this time the centres of learning were in Europe, where astronomers worked with groups of mechanics around them to make models of their ideas in metals and devise elaborate gearings, weight systems, and coiled springs to give the models motion, and escapements to control their rates of motion. Thus these mechanisms incorporated what we now call 'clocks', which made them particularly useful for demonstrating astronomical events.

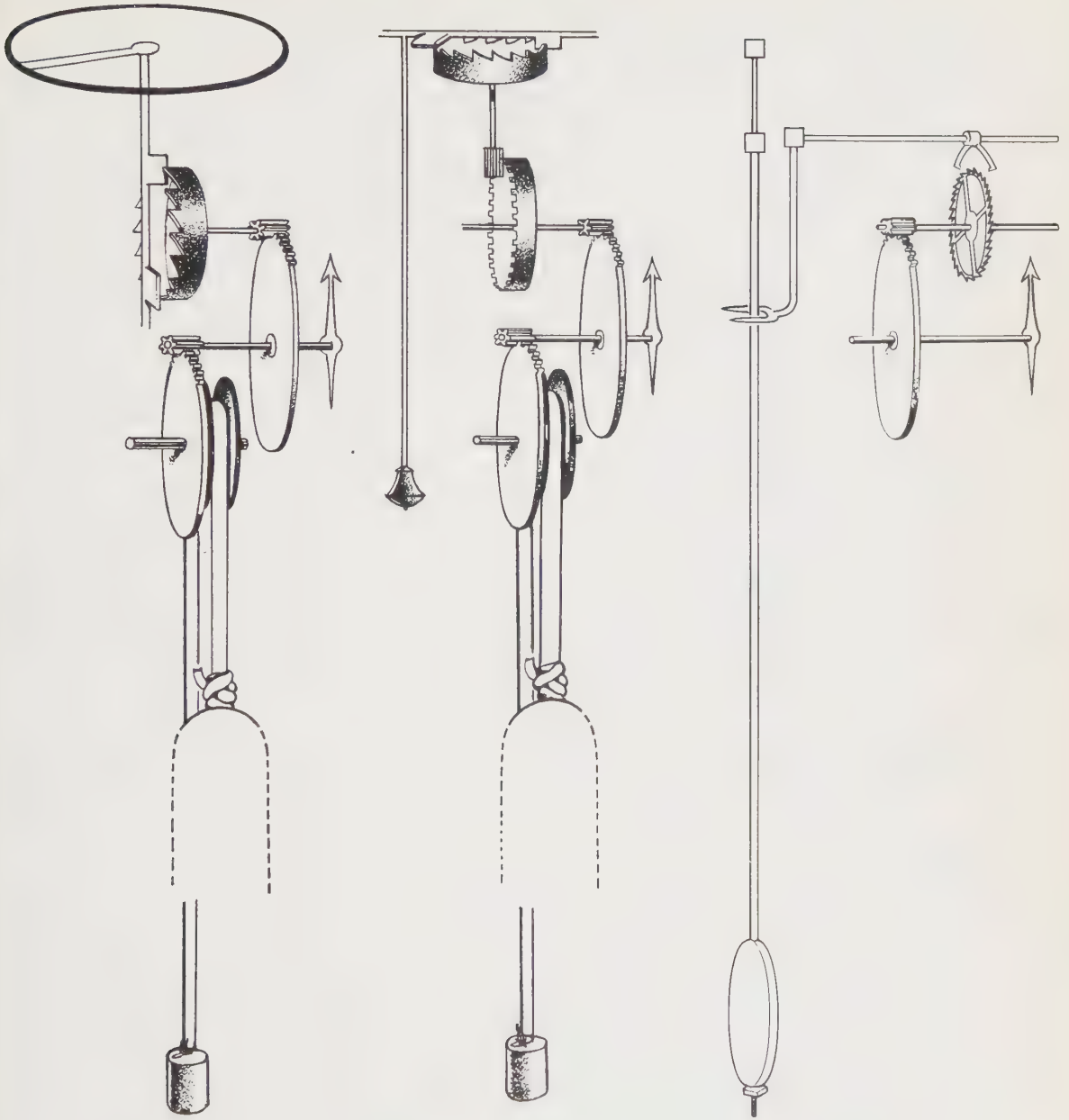

OPPOSITE

Plate 5 The earliest known instructions for construction of clocks were for astronomical clocks. This is one of the drawings of John de Dondi's instructions of *c.* 1364 showing the weight drive. Among many indications it showed the movements of the sun, moon and five planets.

From the fourteenth century onwards, other people than astronomers began to feel the need for timekeepers more convenient than the sun, so the clock part of the astronomical models was divorced from the complicated astronomical gearing and offered as a separate machine. The common clock was born. It has been truly said that the clock is a fallen angel from the astronomers' heaven (see *Plate 5*).

In Cromwell's time, soldiers, parliamentarians, businessmen, and students of natural philosophy (we call them scientists today) would have had real need of clocks. The Protector himself owned several, and there is a watch of his in the British Museum. A lantern clock of his time is quite simple, as shown in *Fig. 1*. A length of rope with a weight at each end runs over a grooved pulley-wheel. The driving weight is much heavier than the other and tries to fall to the ground, thus turning the pulley. The small counterweight is to keep the rope taut so that it does not slip in the pulley groove, which also carries some spikes for the same purpose.

The pulley is attached to the side of a gear-wheel (called the 'great-wheel') by a ratchet arrangement, not by being fixed solidly to it. The ratchet allows free movement one way only, by locking itself against the four arms (called 'crossings') of the great-wheel. The principle is the same as the handbrake of a motor-car which you can pull on but cannot push off (without disengaging it). The ratchet is arranged so that the falling weight will turn the gear-wheel, but when the counterweight is pulled down to raise the driving weight – that is, to wind the clock – the pulley clicks round without turning the great-wheel.

The great-wheel drives a smaller gear which rotates the hour hand round the dial. With the clock as it has been described so far, the driving weight, as soon as it is released after being raised, would descend rapidly to the ground and the hour hand would turn through about twelve hours in a few seconds. What is needed is a controlling device to make the weight descend at such a rate that the hand will turn once round the dial in twelve hours.

The controlling device in all clocks consists of two parts. One is the part that keeps time – something that moves, swings, or vibrates at a steady rate. The other is the escapement – a device to impose the discipline of the controller on the driving force of the clock.

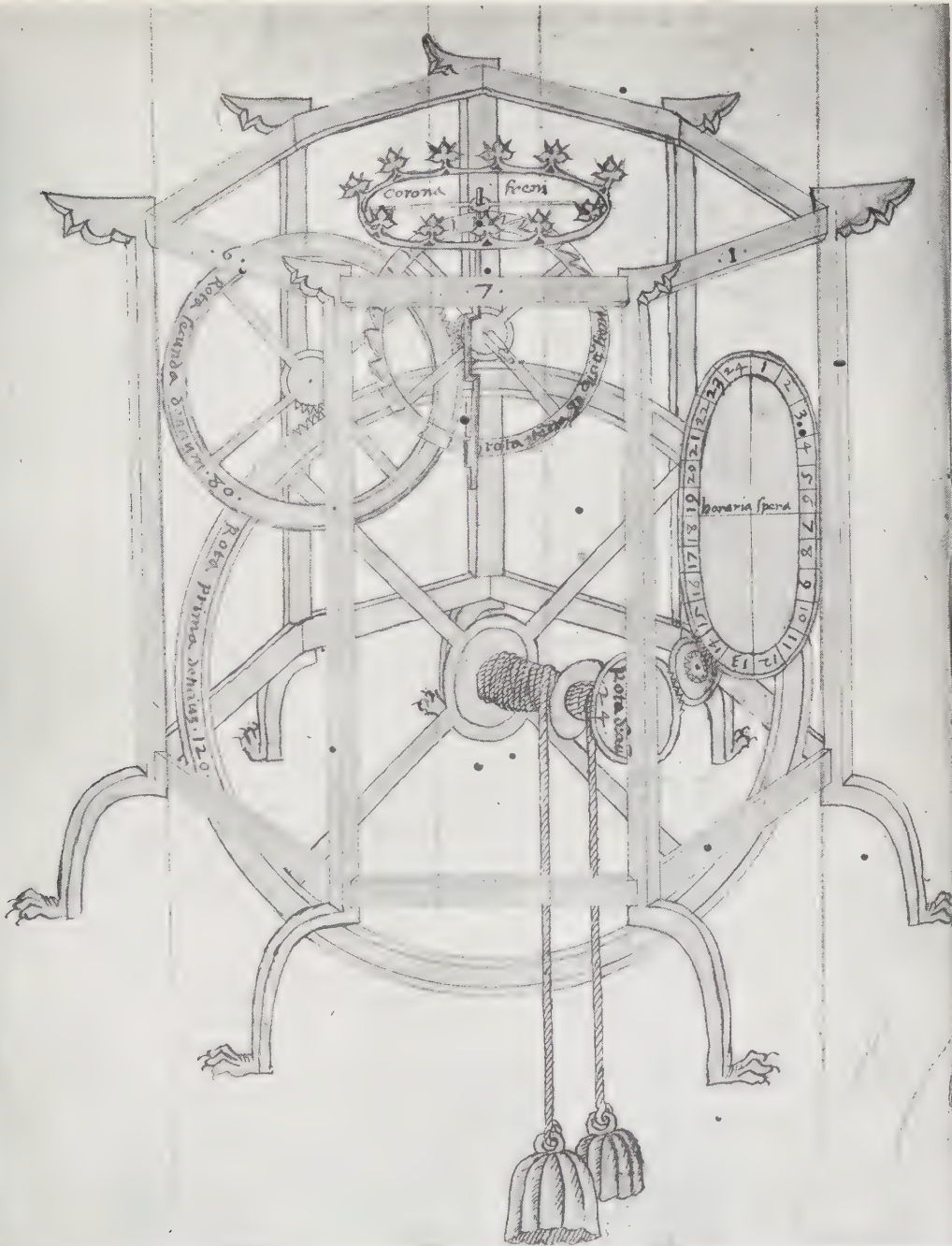

In the lantern clock in Fig. 1, the controller is a wheel called the 'balance' or 'balance-wheel'. This wheel has nothing to do but swing backwards and forwards. Anyone who has tried to swing a fairly heavy wheel backwards and forwards – a jacked-up motor-car wheel, for example – will know that it has a time of its own; it seems determined to swing only at a certain frequency. The period of swing depends on its weight and diameter. This is equally true of the much smaller wheel used as the balance of a lantern clock and the tiny one in a watch.

The balance-wheel of a lantern clock is on the top under the bell and has an axle extending down into the clock movement. The axle has two square projections, the 'pallets', like flags on a mast, and is mounted across the diameter of a special wheel with saw-like teeth. Fig. 1 shows the general arrangement. The saw-toothed wheel, called a 'crown-wheel' because of its likeness to a monarch's crown, is driven by the weight from the same gear-wheel that drives the clock hand. The pallets, however, interfere with the turning of the crown-wheel. A tooth hits one pallet and swings the balance-wheel in one direction. Then the tooth escapes from the pallet, the crown-wheel jumps round, but a tooth on the other side hits the other pallet. This brings the balance-wheel to a stop and gives it a swing in the opposite direction of rotation. Then this crown-wheel tooth escapes from the pallet and the process is repeated with the next tooth the other side.

It will be seen that the crown-wheel cannot be turned without its forcing the balance-wheel to swing to and fro. The balance-wheel, however, has a time of swing of its own which it tries to impose on the crown-wheel, thus regulating the rate of going of the clock.

The axle with the two pallets was reminiscent of the staff with two small flags attached to it carried in procession by a church verger. (Monasteries and churches were the first users of clocks.) Consequently the axle became known as a 'staff' and the whole as a 'verge', names that have persisted until today. With the crown-wheel, the verge comprises the escapement of the lantern clock, and is known as a 'verge escapement'. It has been described because it appears in the very earliest longcase clocks, although not in conjunction with a balance.

There are two important facts to notice about the escapement

described, which will appear again in the longcase clock escapement developed from it. Firstly, the crown-wheel supplies energy to keep the balance-wheel swinging to and fro. It does this by small thrusts of the tips of its teeth on alternate pallets, first in one direction and then in the other. The action is known as 'giving impulse' to the balance. Secondly, it is the periodic swinging to and fro of the balance-wheel that causes the pallets to 'unlock' the crown-wheel at every swing and allow the clock hand to move round the dial in small jumps.

The clock – like almost all mechanical clocks – proceeds in a series of starts and stops. The whole mechanism including the hand is at a standstill most of the time, but about twice a second in a lantern clock it is released momentarily to make a measured jump forwards.

In theory, the measured swings of the balance dictate the rate at which a lantern clock goes. In practice the arrangement is not so good, although no one thought of a better one for two centuries. The trouble is caused by the fact that the balance does not have true domination over the clock weight. A heavier weight will make the clock go faster –and this was the common way of regulating a lantern clock, by adding some lead shot to a cup on top of the weight. Earlier clocks had a verge escapement combined with a swinging bar (the foliot) instead of a balance-wheel.

For centuries the problem of inventing a better alternative to the foliot and balance-wheel had occupied the minds of astronomers and other men of science and the mechanics and clock-makers who worked for them. The interest of astronomers was intense and highly practical, for better clocks meant better celestial observations than their rivals.

Many astronomers are credited with horological inventions and discoveries, but the first to play a part in the history of the longcase clock was the famous Galileo Galilei (see Plate 6). The story is told that as a young man of seventeen, in 1581, he was in the cathedral at Pisa, Italy, when he noticed that one of the great lamps hung by long chains from the roof had been set swinging intermittently by a draught of air.

In those days a man would sometimes use the pulse in his wrist as a convenient timer as it was both 'portable' and reasonably accurate. Young Galileo timed the swings of the chandelier and

noted that this crude pendulum took the same number of pulse beats to swing through a few inches as it did to swing through several feet. It moved slowly when swinging through a short arc and quickly when swinging through a long one, so that the time it took was exactly the same regardless of how wide it swung. This was a triumph of observation, despite its simplicity. For thousands of years, men – highly intelligent and clever men – had watched swinging objects. Yet none had noted this fact.

The story is probably apocryphal since the lamps were hung in the cathedral at a later date, but the fact of Galileo's observation is true and he published information about it. Another fact discovered about the pendulum was that the number of swings it will make in, say, a minute depends only on its length. The usual clock pendulum is a rod with a weight on the end. The amount of the weight on the end makes no difference to the time of swing. If a pendulum with a bob weighing an ounce swings from side to side in a second, so will one of the same effective length with a bob weighing a ton.

Galileo's observation proved that a swinging pendulum was a much better timekeeper than a horizontal wheel or bar that oscillated. Not only did it keep better time but it could be much more accurately adjusted to swing in a particular time. Astronomers soon adopted Galileo's freely suspended pendulum for time measurement. It was extremely simple – like the lamp in Pisa Cathedral, a weight suspended from a chain, or cord. An assistant gave the weight a push, when, say, the astronomer was observing the passage of a certain star, and made a note of the number of swings, giving the pendulum another push when it was coming to rest. As observations could last twenty-four hours or more, this was a wearying business, but it enabled such measurements as the apparent diameter of the sun and the angular distances between stars to be made.

Some astronomers set their minds to devising a mechanical method of counting the swings and of keeping the pendulum swinging without having to give it a push every so often by hand. In fact, they began to think of turning their freely suspended pendulums into clocks, and it was an astronomer in Holland who succeeded. During only three years, his small wall clock with the first pendulum grew into a longcase clock industry in another country, England.



Plate 6 Galileo Galilei (1564–1642) first investigated the properties of the pendulum. He also invented a pendulum clock, details of which were lost for many years.



THE
FIRST
PENDULUM
CLOCK

The man acknowledged as inventor of the practical pendulum clock, which revolutionized timekeeping and heralded the long-case clock, was the great Dutch scientist, Christiaan Huygens (see Plate 7). In 1657, a clockmaker in The Hague, Salomon Coster, made the first pendulum clock to Huygens' specification. This clock is still in existence in the National Museum of the History of Science in Leiden, Holland.

The general style is that often made in The Hague at the time and known as a 'Haagsche Klokje'. It is a small spring-driven wall clock in a rectangular wooden case with a brass dial on a background of black velvet. The pendulum is 13.7 cm long with a verge and crown-wheel escapement.

In 1658, Huygens published a book entitled *Horologium*, the first to deal exclusively with the pendulum clock. It contains a full description of how to construct such a clock, with a working diagram. Within a short time new pendulum clocks were being made in Europe's clockmaking centres, and older lantern clocks with balance-wheels were being converted in large numbers to pendulum operation.

At last, after three centuries, there was a challenger to the balance that offered a better standard of timekeeping.

Although the most profound influence of Huygens' work was on the English clockmakers, and their quick adoption of the pendulum enabled them to dominate the world in clockmaking, it is strange that no translation of his book *Horologium* into English was published until mid-twentieth century! Two translations were



Plate 7 Christiaan Huygens (1629–95) made a thorough analysis of the action of the pendulum and invented the first practical pendulum clock.

Plate 8 Some sketches made by Huygens in 1659 of his pendulum clock with cycloidal cheeks, horizontal verge, and endless rope drive.

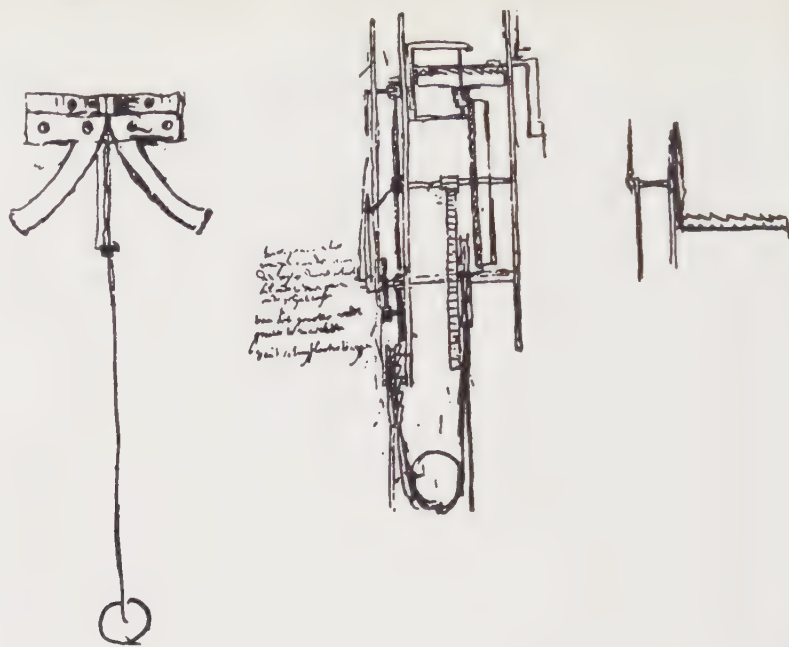

made by two authors unknown to each other, from the original Latin. One was by Ernest E. Edwardes and appeared in the UK in the *Horological Journal* of July and August, 1954. The other appeared in the USA in George H. Eckhard's book, *Pennsylvanian Clocks and Clockmakers*, published early in 1955. There is a wide difference between the words used but not in the meanings.

Huygens began: 'I thought out a new method of measuring time at the end of the year 1656, and in the next few months began to divulge it in our country (Holland), not doubting that on account of its exceptional utility it will soon be spreading far and wide, with many copies of the new work, in fact, already for sale and for sending forth in all directions. Nevertheless, I yielded not unwillingly to the advice of those who urged that I should publish a written description, as much to oblige those in distant parts, whom the new method, perhaps, would otherwise reach later, as in order that I should meet the audacity of men of ill-spent leisure, lest – as is customary with them – they should seize upon other inventions and, most injuriously, sell them as their own.' He then referred to his patent granted in 1657 (see Plate 8 and Fig. 2).

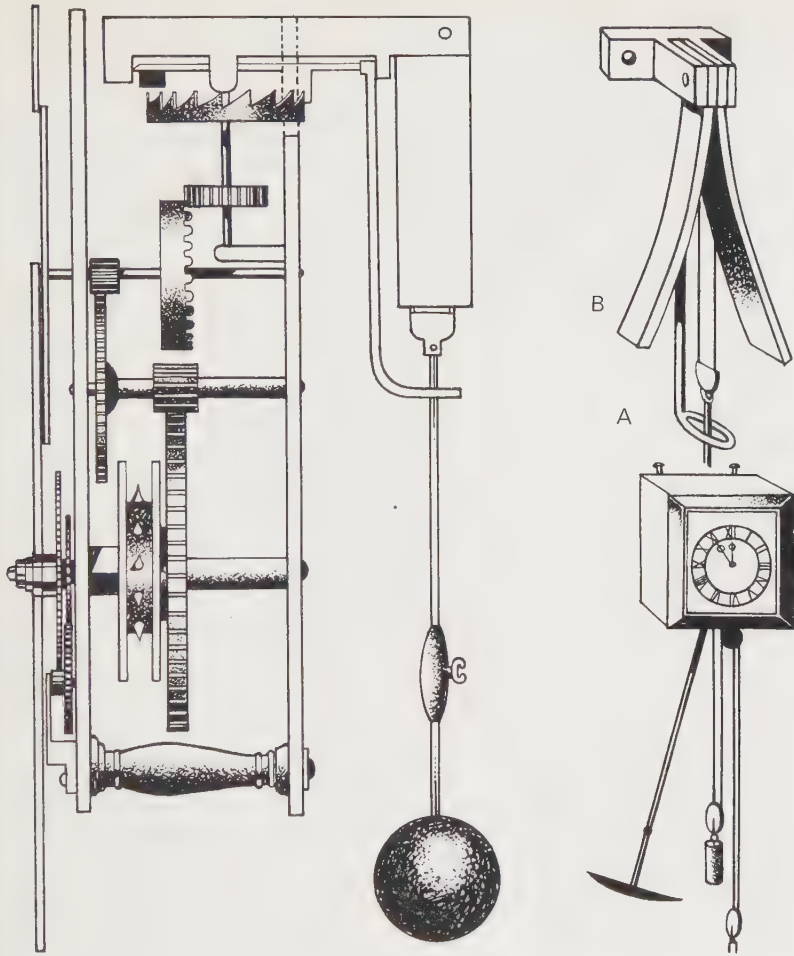

Fig. 2 Huygens' design for the pendulum clock, showing the pendulum suspended separately from the movement, the crutch (A) and the cycloidal cheeks (B). This is copied from an illustration in *Horologium Oscillatorium* of 1673.

Huygens' expectation of others seizing upon his invention was well founded, for any clockmaker hearing and making use of it might have claimed it as his own had not Huygens published the details of his patent.

There were other men of science and mechanics genuinely striving to invent a pendulum clock before this time. One of them was the Italian, Galileo, who had discovered the value of the freely suspended pendulum. He had been dead several years when Huygens announced his invention.

Galileo had a pupil and close friend named Viviani, who published a biography of him in 1654 but made no mention in it of a clock, or Galileo's application of a pendulum to one. After Huygens' book on the pendulum clock came out in 1658, however, Viviani awoke to the fact that he had missed an important claim for his hero. He therefore tried to establish the fact that Galileo was the true inventor. As a result, a certain amount of jealousy and resentment at Huygens' 'invention' was aroused in Italy, and one academy even published a falsified picture of 'Galileo's clock'. The accusation reached Huygens' ears and he asked the French Ambassador to present a copy of *Horologium Oscillatorium*, a second and mathematical treatise on the pendulum he had published in 1673, on his behalf to the Prince Leopold, who was a scientific man. (He had already sent the Prince a copy of his first book, *Horologium*, in 1658.) He wrote a letter expressing dismay at being unjustly accused by the Accademia del Cimento. The Prince replied, '... I can certify to you, in all sincerity, that I believe definitely likely that it has never come to your knowledge that the idea to apply the pendulum to a clock had also presented itself to our Galileo, this having been known only to a few, and he himself having brought nothing of this project to practical completion, as can be seen by the little done by the hands of his son ...'

The truth of this claim for Galileo might never have been proved except for an astonishing series of circumstances about eighty years later. An Italian professor discovered that the meat from the butcher had been wrapped in some pages of an old manuscript. He examined it curiously and found it to be written in Latin by Galileo. As soon as possible he visited the butcher and managed to recover a collection of invaluable documents.

Apparently, Viviani had come into possession of all the manuscripts and unpublished work of Galileo as well as correspondence given to him by Galileo's son, Vincenzo. Because of the political or religious situation, he thought the documents might incriminate him, so he hid them in the bottom of a bin of grain in his home in Florence. After he died, they remained hidden for thirty-four years until discovered by his nephew, who sold them by weight for wrapping paper to a local butcher's shop.

One paper was a letter written by Viviani himself in 1659 to Cardinal Leopold. It gave the complete story of Galileo's invention, which occurred to him in 1641 when he was blind and unable to make designs or models. He told his son, Vincenzo, about it and Vincenzo decided to make a model, but construction kept being postponed, and in 1642 Galileo died. Vincenzo then lost interest and only started to construct the clock in April 1649, after employing a mechanic to make the iron framework and the wheels, intending to complete the secret parts of the clock himself.

The clock was almost finished when Vincenzo was seized with fever and, while in a delirium, stormed through his house smashing up his most valuable clocks. Then, as Viviani wrote, he passed on 'to measure the moments of Eternity'. The pendulum clock escaped his rage for when his widow died in 1669, she left in her will 'an iron clock, unfinished, with pendulum, original invention of Galileo'. It has not survived until today, alas, but a drawing of

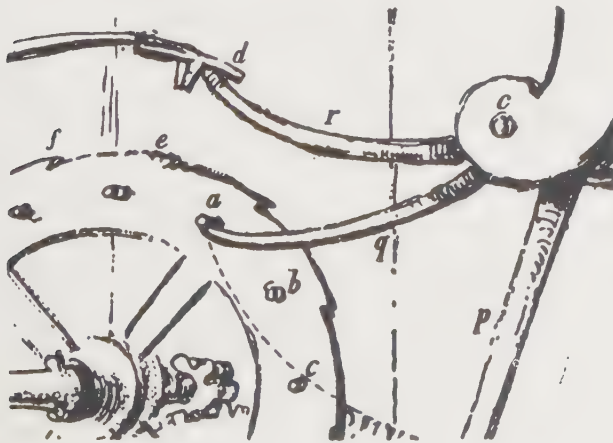

Plate 9 The escapement designed by Galileo according to Viviani. It is reminiscent of a chronometer escapement but was discovered too late to have an influence on the history of clocks.

the pendulum and escapement was discovered in 1856 (see Plate 9) and a model was later made for the Science Museum, in London, where it now works.

So Galileo really had an excellent claim and if he had not been so obsessed by secrecy and had published his discovery like Huygens, he would probably have altered the course of horological history, for his invention was different from and fundamentally better than that of Huygens. In fact, it was swept aside by the tide of progress in another direction.

Another man who struggled with the problem of mechanizing the pendulum was Hevelius, one of the greatest astronomers of the seventeenth century. He lived in Danzig, at that time a centre of culture, where he used sundials, water clocks, sand clocks, and mechanical clocks controlled by swinging foliots and driven by springs and by weights. His water clocks and sundials were divided into minutes. None of these timekeepers or his pulse was accurate enough for his astronomical measurements. Towards the end of 1640 he read the book by Galileo describing his discovery about the isochronism of the pendulum. He frequently made use of cord pendulums after that, but found it laborious, and eventually evolved a mechanical drive and counting mechanism, but several years passed before he was able to have his clocks made, partly owing to the opposition of one of the craftsmen he employed who refused to believe that something so unorthodox could possibly work. He succeeded just at the time Huygens published his *Horologium* but instead of claiming the invention himself, warmly congratulated Huygens.

Meanwhile, practical clockmakers were approaching the same end by quite a different method, by modifying the controller they knew so well – the foliot, the swinging horizontal bar with a small weight at each end. By removing one arm and turning this through ninety degrees, it becomes a pendulum.

About 1658–9, two brothers, Guiseppe and Matteo Campani, the first an astronomer and clockmaker and the second an expert lens maker, were experimenting with a night clock. They had received a commission to make a clock which could be illuminated and would be quiet. Orthodox clocks of the time had noisy ticks. The brothers began to experiment with different foliots and balances, one of which was a long bar with lumps of

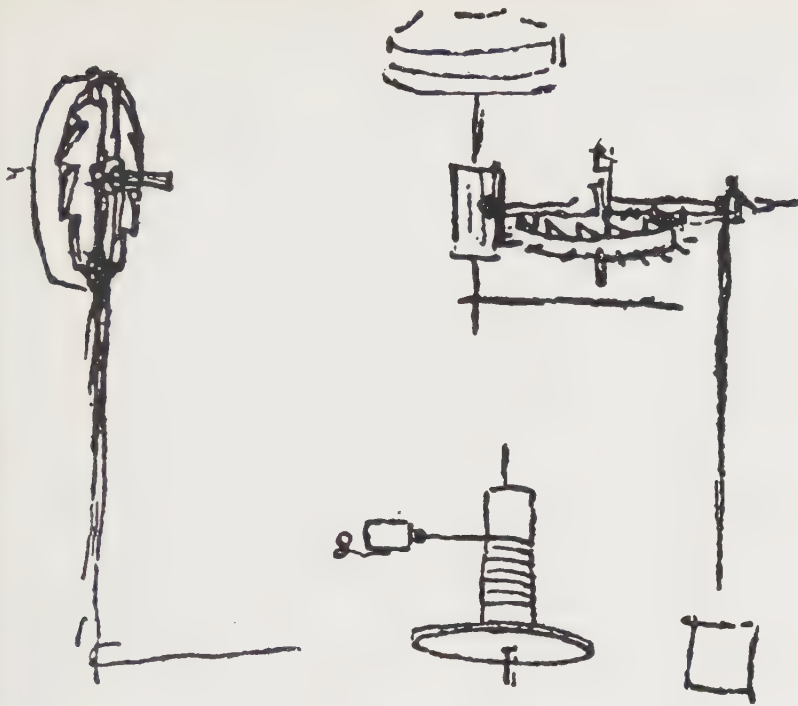

Plate 10 Leonardo da Vinci appears to have anticipated the horizontal verge with short pendulum in his sketches of 1452–1519. Ironically, although Huygens' more advanced design was used for longcase clocks, makers of table and bracket clocks reverted to the pendulum fixed to the verge of da Vinci.

wax at each end for the weights. This was being tried vertically, and while Guiseppe was watching it swing slowly to and fro one day, the upper weight fell off. To his astonishment, so he records, the clock continued to work 'with the balance out of equilibrium'. He said he found the going was extremely regular, and showed the clock to his brother, who remarked that it was 'a great invention and in fact the pendulum discovered by Galileo'. That, at least, is the story.

Guiseppe (not appreciating that the force of gravity was involved) made a watch with a pendulum which he hung from his neck and took to the Grand Duke of Tuscany. He was amazed when the Duke showed him a print of Huygens' invention and also a large old chamber clock with a pendulum made by Galileo. The print must have been that in the book *Horologium* which Huygens had sent to Prince Leopold, who was the Grand Duke's brother. The clock may have been the unfinished one left by Vincenzo Galileo's widow.

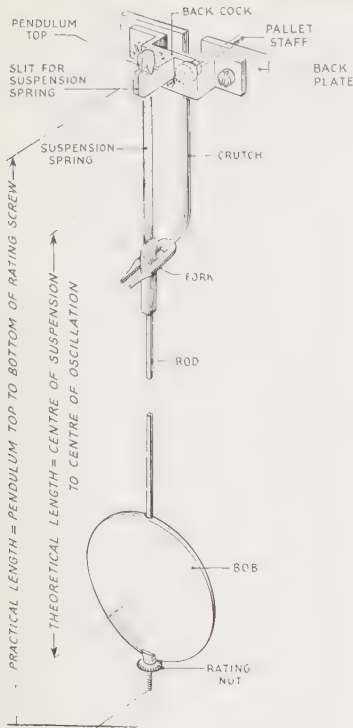

Fig. 3 The crutch and pendulum of a longcase clock with seconds pendulum. (Drawing by courtesy of the British Horological Institute Correspondence Course.)

To complete the story, the most astonishing records of all are drawings by Leonardo da Vinci in his sketch books of 1452–1519 (see Plate 10). He made two designs of pendulums with verge and crown-wheel escapements suitable for clock use, but showed no complete clock with them. There is no evidence that his idea was ever put into practice or became known. If it had, the pendulum, and perhaps the longcase clock, would have been with us over 150 years before it was.

Huygens was a mathematician as well as a practical inventor. He made another fundamental discovery about the pendulum before he launched his pendulum clock.

He discovered that Galileo's principle of a pendulum being isochronous – that is, swinging from one side to the other in exactly the same time regardless of the angle through which it is swinging – is only approximately true. A pendulum swinging in a wide arc goes a little slower than one with a small arc of swing. (To be isochronous, a pendulum must swing in a steeper, cycloidal curve.)

If a pendulum swings with constant amplitude, its timekeeping will not be affected. It is only when the arc of swing varies that timekeeping suffers. Huygens realized this and took account of it in his design, claiming, 'my timepiece is less liable to an inequality of this kind, because all the vibrations are of equal amplitude'. The verge escapement from the lantern clock (see Fig. 1) which he employed with his pendulum caused a large pendulum amplitude, comparable with the swing of the balance-wheel of a lantern clock, and to reduce this and therefore the variations in amplitude, he interposed gearing between the pendulum and escapement in the first design.

The first clock made for him by the clockmaker, Salomon Coster, did not include this gearing, however. It was not sound engineering and the practical Coster may have persuaded Huygens that his design should be changed. The first pendulum clock therefore has no gearing between verge and pendulum. Instead there is an arrangement (almost useless in practice) to make the pendulum swing in a cycloidal curve (see B Fig. 2), instead of an arc, and therefore be isochronous. The lack of isochronism of a pendulum was studied in greater detail later by Huygens and treated mathematically in his second book,

Horologium Oscillatorium (1673). It is called 'circular error'. In his second book, Huygens also offered the first accurate explanation of what is meant by the 'length' of a pendulum.

Huygens thus provided the first fundamental of the longcase clock – the pendulum. He also provided another, which contributed to its dominating other forms of timekeeper in accuracy for so long. This was the method of connecting the pendulum to the clock movement itself by means of a short lever known as the 'crutch' (see Figs. 2 and 3). This arrangement enables the pendulum to be hung from a bracket of its own, quite independent of any working bearings of the clock which might wear or vary in friction because of drying oil. Its length is therefore fixed and invariable. On this occasion he knew not how well he invented. He probably employed the crutch for constructional reasons without realizing its significance.

A third invention in Huygens' first pendulum clock was incorporated in the hundreds of thousands of lower priced longcase clocks made in centres all over Great Britain for two hundred years and is today the basis of all automatic winding mechanisms for public clocks. It is known as 'Huygens' endless rope'. When one of the old lantern clocks was being wound, the source of power was removed and the clock slowed down or stopped. In Huygens' arrangement, as shown in Fig. 4, the clock is wound by pulling the rope marked A which raises the driving weight by pulling the part of the rope B upwards. At the same time, however, the weight, because it is suspended from a pulley, is acting on C and driving the clock. Thus there is no loss in timekeeping during winding. Such provision for keeping the clock going while winding is called 'maintaining power'. The more often an accurate clock has to be wound, the more important it is to provide maintaining power.

These discoveries and inventions from which the longcase clock was born can almost all be credited to Christiaan Huygens of Zulichem, working in Holland. The bachelor, Huygens, a fine-looking man, noted in his time also for his strength, his musical, literary, painting, and engraving talents, as well as his scientific discoveries, became well known to English clockmakers as well as men of science, so we now move across the Channel to Britain.

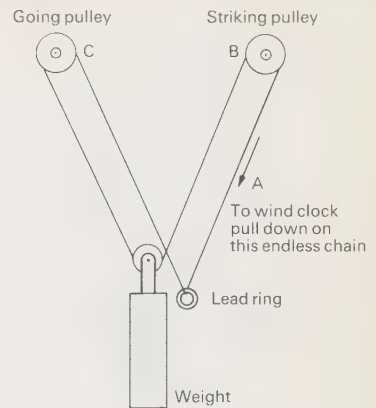

Fig. 4 Huygens' endless rope, which provides maintaining power and also enables one weight to drive both timekeeping and striking gear trains.



CHAPTER THREE

DEVELOPMENT
OF
THE LONGCASE CLOCK

In the English news sheets, *Mercurius Politicus*, of 27 October 1658, and the *Commonwealth Mercury* of 25 November 1658, appeared the following advertisement:

There is lately a way found out for making clocks that to exact and keep equaller time than any now made without this Regulator (examined and proved before his Highness the Lord Protector by such Doctors whose knowledge and learning is without exception) and are not subject to alter by change of weather, as others are, and may be made to go a week, a month, or a year, with once winding up, as well as those that are wound up every day, and keep time as well, and is very excellent for all House Clocks that go either with springs or weights; and also Steeple Clocks that are most subject to differ by change of weather. Made by Ahasuerus Fromanteel, who made the first that were in England. You may have them at his house on the Bankside, in Mosses Alley, Southwark, and at the sign of the Mermaid, in Lothbury, near Bartholomew Lane end, London.

One of the first longcase or grandfather clocks, made by Ahasuerus Fromanteel between 1660 and 1665. The wood is architectural in style and the case is relatively short and narrow because the dial is small and the movement was a short pendulum. It is in the famous Ilbert clock collection that now belongs to the British Museum.

The 'Regulator' referred to by Ahasuerus Fromanteel was the pendulum invented by Huygens. Ahasuerus, a thinking man of business, as well as a practical clockmaker, was keenly aware of the value of acknowledging the interest displayed by Oliver Cromwell, of whom it was said, 'if there is a man in England who excelled in any faculty or science, the Protector would find him out, and reward him according to his merit'.

Note the date, 1658, the same year as that in which Huygens announced his invention. How did Fromanteel manage to hear of it and translate it so quickly into practical business? It would be a rapid translation today; in the seventeenth century it was incredible.

It has been said that as the Fromanteel family was of Dutch origin, he kept in touch with events in Holland. In fact he was a third generation Englishman. Nevertheless, he must have kept in touch by letter with events in Holland. Near the beginning of the seventeenth century Ahasuerus came to East Smithfield, where he made steeple clocks, that is, large clocks for public use. He was one of the first members of the Worshipful Company of Clockmakers, incorporated by a Charter of 1631 to regulate the trade in and around London by controlling apprenticeship and by searching for 'bad, deceitful, or insufficient clocks, watches, larums, sundials, boxes, or cases for the said trade' in order to destroy them.

Ahasuerus Fromanteel, and his clockmaker associate and son-in-law, Thomas Loomes, fretted under the Clockmakers' Company regulations, particularly those relating to apprentices, and were frequently in trouble for disobeying them. One of the large Fromanteel family, John, was apprenticed to Thomas Loomes at the age of about thirteen in 1651 and while still serving was sent over to The Hague in Holland to learn the art of making pendulum clocks from Salomon Coster. Huygens had assigned to Coster the right of making his pendulum clock for a period of twenty-one years. Yet only eleven weeks after the grant of the patent, young John Fromanteel was in The Hague working for Coster.

An agreement between John Fromanteel and Coster refers to a secret that Coster agreed to hand over before the agreement expired. It was probably something unrelated to the pendulum clock; no one has discovered a clue to it. Coster agreed to pay John Fromanteel twenty goulden for every clock he made if he provided his own brass and steel, and eighteen and a half goulden if he did not supply these raw materials.

The details of making pendulum clocks were transmitted to his family in England by John Fromanteel, with the acquiescence of Huygens or Coster, and, by the time John returned, his family had

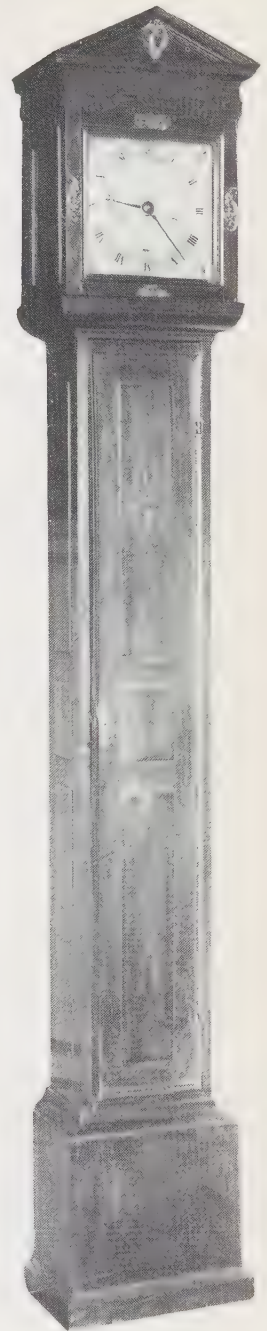

been in business for some time as pendulum clockmakers. Salomon Coster was not destined to reap the benefits of the licence granted him; he died after only two years of the term had elapsed.

Mosses Alley, where Ahasuerus Fromanteel, his family, and apprentices lived and worked, was an alley leading from Maid Lane to the northern end of Bankside. The other address given in the advertisements was that of Thomas Loomes.

The popular brass lantern clock of this time was sometimes made with a square dial plate instead of circular dial, and given a wooden case, although the general construction of the movement inside with four corner posts, known as a 'bird-cage frame', remained the same (see Plate 73). But changes in the design of the movement were also occurring, by introduction of the plate frame, two brass plates separated by pillars (see Fig. 5) used in Huygens' prototype.

With the lantern clock two weights were usual, one for driving the timekeeping train of gears and the other to provide power for the striking train, and the two barrels which they turned were placed end to end. One turned clockwise and the other counter-clockwise to separate the weights so that they did not touch in passing. The weights were wound by pulling on the free end of the cord of each. With a plate frame, the barrels are placed side by side so that the ends of their arbors or shafts can protrude through the dial. It is thus possible to wind them by key from the front.

The English wall clock with a plate frame and a short pendulum at the back was made with a wooden case and driven by weights instead of springs. The weights hung below it, as with the lantern clock, but were wound up by a key. The hooded wall clock, as it was called, remained in production for about fifteen years, from 1660 to 1675 (see Plate 103).

Pendulum clocks driven by springs were developed at the same time in England and the earliest were similar to hooded wall clocks in the architectural designs of their wooden cases with brass dials. They had the advantage of being portable and became known generally as bracket clocks. They were stood on furniture or on special small brackets made for them and attached to the wall.



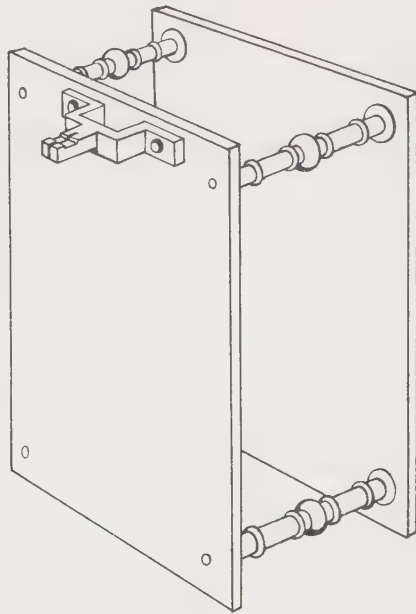
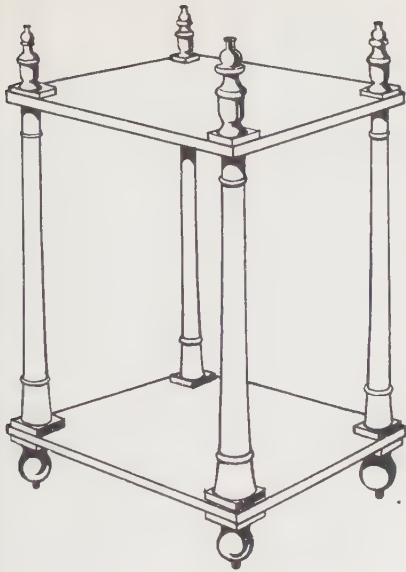

Clocks standing on pedestals were known in Europe. Some incorporated the pedestal and clock case to provide a floor-standing clock. The English longcase clock may have developed from this, or may have been a development of the enclosed lantern clock or hanging wall clock, by enclosing the weights in a wooden trunk.

The short pendulum used by the Fromanteels and other London clockmakers who soon followed their lead was about ten inches in length (see Plates 11 and 78). A pendulum of this length 'beats' half seconds or thereabouts; that is, it takes half a second to swing from one side to the other so that the clock ticks every half second and the hands proceed in little jumps half a second apart.

The half-seconds pendulum was associated with a verge escapement, or crown-wheel escapement as it was also called, similar to that illustrated earlier in Fig. 1, and was forced to swing in a wide arc of about fifty degrees, which produces a very vigorous action and a distinctive tick. Not all short pendulums were ten inches long; many were shorter.

Another invention had to be made before the true longcase

ABOVE

Fig. 5 The pillar frame (*left*), which turned sideways, became the plate frame (*right*) used for longcase clocks.

OPPOSITE

Plate 12 Elaborate finials embellish the hood of a Fromanteel and Clarke clock. It is 7 feet 9 inches high and was made after 1700. It runs for a month and has quarter chiming and an alarm as well as other indications. Note the chest-style feet. It has an anchor escapement and long pendulum.



ABOVE

Plate 13 Mr M. Aimer, a well-known horologist, made this model to show how Hooke may have impulsed a pendulum from a pin on the rim of a watch's balance-wheel.

OPPOSITE

Plate 14 An 8-day striking clock with long pendulum and anchor escapement by William Clement, made about 1680. The ebonized case is 6 feet 6 inches high and there is only one hand.

clock was created. It was a logical improvement to the use of a pendulum as a timekeeper.

Astronomers employing Galileo's freely suspended pendulum found a long one was less fatiguing to keep swinging than a short one. Its slow beat was also easier to count. It was known that a pendulum of about thirty-nine inches – just about a metre, although that measure had not then been invented – could be adjusted to swing from side to side in exactly one second.

With this, timekeeping would be more accurate. The reason was, the wider the arc, the greater the time discrepancy caused by variations in arc. So if a long pendulum could be used with a small angle of swing there was less likelihood of timekeeping variation caused by circular error. Moreover, the longer the pendulum rod, the less the effect on timekeeping of changes in length caused by temperature variations, it was later discovered.

The difficulty was practical: How to apply a long pendulum to a clock movement. During the latter part of the seventeenth century, much thought and ingenuity was expended on the problem. It was possible to attach a seconds pendulum to a verge escapement, of course, but the fifty degrees arc of swing meant that the pendulum bob would swing through nearly three feet, and although by adjustment this would be reduced considerably, it was not a practical scheme. French clockmakers some years later did modify the verge escapement slightly so that a long pendulum employed with it swung through only ten to twelve degrees, but this was a poor solution.

A prominent thinker in old London of this time, a few years after the Great Fire, was Dr Robert Hooke, the first experimenter of the Royal Society, who offered a plan with a square pattern of streets for rebuilding the City of London which was turned down, but became one of the surveyors, with Sir Christopher Wren.

Hooke was a brilliant, misunderstood man described as 'nothing but skin and bone, with a meagre aspect . . . his chin sharp, and forehead large . . . He wore his own hair of a dark brown colour, very long and hanging neglected over his face uncut and lank.' He was sent to London from his home in the Isle of Wight to become apprenticed to the famous portrait painter, Lely, but instead spent the money attending Westminster School, where he learned the first six books of Euclid in a week, absorbed all the mechanics the

masters knew, learned Latin, Greek, and several oriental languages, and to play the organ.

He was well known to the top clockmakers and collaborated with the famous Thomas Tompion. From his own times and today there have been fierce arguments about his contribution to horology and for many years it was believed on the strength of later statements and an entry in his diary that he made it possible to use a long pendulum on a clock, but it is now known that the pendulum 'clock' invented by Hooke and demonstrated to members of the Royal Society in 1669 was driven by a watch movement acting on the bottom of the bob of a 14-foot pendulum rod (see Plate 13).

The credit for inventing the practical long pendulum clock is usually given to an eminent London maker named William Clement, who graduated to clockmaking like others of his time from blacksmithing. In 1670, Clement was invited to inspect a large clock at Kings College, Cambridge (and paid £1.50 expenses for doing so). He recommended a new clock of his own design which was completed in 1671 and for which the College paid him £42.

This clock is now in the Science Museum, London. It bears Clement's name and the date 1671, and is the earliest existing one with a device known as the 'anchor escapement', which was the secret of applying the long pendulum to a clock. A longcase clock by Clement is shown in Plate 14.

Joseph Knibb is also credited by some with the invention of the anchor escapement. A church clock made by him in 1678 has been 'discovered' recently in the village of Burnley in Rutland (now Leicestershire) with an anchor escapement that is connected to the separate pendulum arbor by a pair of levers. Before 1671, Knibb had been experimenting with a form of recoil escapement that had two separate verge-like pallets. It may be that he was the true inventor of the anchor escapement.

The anchor was so named because of its likeness in shape to a ship's anchor. The escape-wheel is in a vertical plane instead of being horizontal like the crown-wheel, and is shown in Fig. 6. It has teeth similar to those of the crown-wheel and is really a flattened out crown-wheel. Above the escape-wheel is the anchor, which has two pallets spanning seven and a half teeth. The pendulum is attached to the anchor (by a crutch as in Huygens' original clock) so that, as the pendulum swings from one side to



the other, the anchor is rocked. First one pallet and then the other holds up a tooth of the escape-wheel, which of course is trying to turn under the influence of the driving weight.

The pallets are curved, so that as one lets a tooth pass under it, the tip of the tooth gives the pallet a push to rock the anchor and therefore to impulse the pendulum to keep it swinging. The other pallet similarly impulses the pendulum in the other direction. The escape-wheel and anchor therefore keep the pendulum swinging; but the 39-inch pendulum, by its nature trying to swing in exact seconds, imposes its timekeeping on the clock which thus proceeds in a series of tiny jumps, one every second.

The anchor escapement demands an arc of only five degrees or less from the pendulum in order to work efficiently.

Clement's clock was apparently very successful in its timekeeping performance because the anchor escapement was introduced very quickly by other makers. It led immediately to the adoption of long cases by English makers because a protective case was necessary for the pendulum, which hung a long way below the clock. The anchor was incorporated eventually in almost all pendulum clocks and has not been superseded even today for domestic clocks with pendulums.

At the time the more sophisticated new clocks made with a pendulum had two hands showing hours and minutes. Clement's

Fig. 6 The anchor escapement, the second invention that made the longcase clock possible. It rocks to and fro at a rate determined by the pendulum to let a tooth escape first at one side and then at the other.

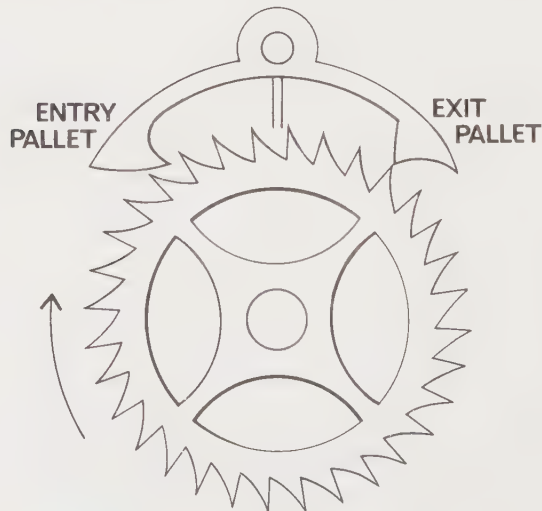

invention made a third hand a practical proposition. The escape-wheel jumped forward a distance of half a tooth each second. If it had thirty teeth, it would revolve once in a minute in sixty jumps, and a seconds hand could be attached directly to it. A seconds hand therefore also became a feature of many longcase clocks.

An alternative name for the anchor escapement is the 'recoil escapement'. The reason is that the escape-wheel (and seconds hand) does not jump forwards and then stop dead; it recoils slightly. The slight backward movement is easily seen by watching the seconds hand of a longcase clock. The action has a purpose. It enables an anchor to be made without undue precision and also tends to limit the arc of swing of the pendulum and therefore minimize the influence of circular error.

The chief reason for the success of the long pendulum is a matter of leverage. To be successful, the pendulum must impose its timekeeping on the clock movement. A swinging bob on a 39-inch rod exerts more force on the escapement than one on a rod of, say, ten inches, because of the greater mechanical advantage. The principle is the same as levering a stone out of the ground with a crowbar; a long one has more control over the stone.

The seconds pendulum was so convenient that clockmakers of the day sometimes called it the 'Royal Pendulum' in honour of the patronage of King Charles II, which they valued. It was thought that a still longer pendulum might be even better so some makers began to experiment with pendulums of various lengths. Clement, as well as others, made longcase clocks with pendulums of about sixty-one inches which beat one and a quarter seconds. Such clocks can be recognized at a glance because there is a circular glass near the bottom of the case opposite the end of the pendulum.

But there was no real gain in such long pendulums and after the first few years of the eighteenth century, clockmakers lost interest in them, for domestic clocks, anyway. Occasionally very long ones of about fourteen feet beating two seconds (like that Hooke employed in his pendulum 'clock') were used for special timekeepers, such as the two made by Tompion in 1675–6 for the Greenwich Observatory, which had just been established. Tompion employed Hooke's idea of using the pendulum above the movement (see Plate 13). Reproductions of these clocks can be

seen in the Octagon Room at Greenwich Observatory. Another clock he made for the first Astronomer Royal is shown in Plate 15.

The lantern clock did not vanish when the true longcase clock appeared on the scene. Many continued to be made with little change until about 1700 in London, and around 1750 in the provinces. The pendulum designed by Huygens showed such an improvement in timekeeping that lantern clocks after about 1660 were made with short pendulums and verge escapements with horizontal crown-wheels. After about 1675, lantern clocks were made with long pendulums and anchor escapements. After this date, most earlier lantern clocks, particularly those with balance-wheels, were converted to long pendulum operation (see Fig. 1).

Traditional lantern-clock construction was employed for some longcase clock movements by the top London clockmakers as well as by other London and many provincial makers. The earliest had short pendulums (see Plates 76–8). The anchor escapement and long pendulum were rapidly introduced, however, after their invention. The clock usually, but not always, had an hour hand only and quarter hour (not minute) divisions on the dial, but its brass dial was square and it was in a regular long case made of oak. The movement still had the time and striking trains end to end (one behind the other), instead of side by side as in a true longcase movement – and it had to be wound daily by pulling up the weight by a rope or chain like the lantern clock. Such clocks were made from after the introduction of the pendulum through the eighteenth century and someone coming across such a one-handed longcase clock today for the first time might be tempted into thinking it earlier than it is.



FAR LEFT

Plate 15 Thomas Tompion made several special timekeepers for the first Astronomer Royal, John Flamsteed. This one, made in 1691, was designed to display angular movements instead of hours and the pendulum beats $\frac{2}{3}$ second to record 360° in 24 hours. See also Plate 84.

LEFT

Plate 16 The marquetry here is in realistic flower pattern on a burr chestnut ground. The clock was made by John Adamson of London about 1700. Note the flat top with ball finials and the apron below the plinth.



CHAPTER FOUR

TIMEKEEPING,
STRIKING
AND
CHIMING

One reason for the accuracy of the longcase clock – apart from its seconds pendulum – is that it is driven by a weight instead of a spring. The weight provides energy – kinetic energy – by falling to the bottom of the case under the influence of gravity and since the force of gravity is unchanging in any one place, so is the power derived from a falling weight.

A spring, on the other hand, provides more power when it is fully wound than when it is run down and various arrangements – notably a device called a ‘fusee’ – are necessary in accurate spring-driven clocks to make the output of the spring reasonably constant.

Clocks intended to be wound daily usually have a movement that will go for about thirty hours before running down, in order to allow for variations in the times when it is wound. For the same reason a clock intended to be wound weekly will usually go for eight days, and is called an 8-day clock.

There is a traditional rhyme that illustrates the point:

*There was a man who had a clock
His name was Mr Mears.
And every night he wound that clock
For five and forty years.
And when at last that clock turned out
An eight-day clock to be
A madder man than Mr Mears
I never hope to see!*



Plate 17 A magnificent Thomas Tompion clock in a walnut case. It has a 24-hour dial and an equation of time dial in the arch, and the movement goes for a year with one winding. It was made about 1695, and has the first known break-arch dial and hood. The anchor escapement is under the movement. *Reproduced by gracious permission of H. M. The Queen.*

The advertisement of Ahasuerus Fromanteel which has been quoted, referred to clocks going for a week, a month, and even a year, at one winding.

A longcase year clock by Tompion for King William III about 1695 now belongs to the Queen and was shown to the public in the Five Centuries of British Timekeeping Exhibition. This has a very early example of equation (see page 106), which is set in the first break-arch dial known (see Plate 17).

Month clocks were constructed for special customers by some of the best clockmakers, the extra power needed being provided by a weight nearly three times as heavy as that for an 8-day clock, and a higher gear ratio in the clock. They included striking work and sometimes chimes as well, as with a fine one made in 1735 by James Markwick and now in the Victoria and Albert Museum. A number of three-month clocks were also produced (see Plate 18). Six-month and year clocks are very rare and usually have no striking train, as it is difficult to arrange a weight to provide sufficient power for striking over these long periods. Even the weight for timekeeping has to be very heavy indeed.

Two-day clocks were occasionally made, but are now very rare.

The 30-hour longcase movement is found in clocks made throughout the longcase clock period, particularly those from clockmaking districts outside London. Almost invariably it has the Huygens' endless rope or chain, so that on opening the door in the trunk four ropes or chains are seen. The main cast iron or lead weight is suspended by a pulley in the loop of two of the chains. The other chains are kept in tension and in their grooves by passing through a small ring-shaped lead weight which hangs clear of the bottom of the case. The driving weight is rewound by pulling on one of the free chains. (Pull-up winding is only very, very rarely found on 8-day clocks, and then late ones, although it has even been employed on month clocks.)

An 8-day clock is wound by a key inserted through the dial. The key, normally crank-shaped, turns a barrel, winding on to it a length of gut. The other end of the gut is fixed to the seat board – the horizontal board on which the movement is mounted – and the weight is suspended from a pulley in the loop of the gut.

It will be found that an 8-day clock is wound clockwise. If the

OPPOSITE LEFT

Fig. 7 Rates of the wheels in the going train of a longcase clock movement.

OPPOSITE RIGHT

Plate 18 An early clock by Joseph Knibb that runs for three months at a winding and has Roman striking. Note the IV instead of III. The long door of the ebonized case is an indication of early date.

key has to be turned anti-clockwise, see whether the clock runs for a month otherwise you may discover yourself in the position of Mr Mears. The reason for the change of direction is that an extra wheel has to be inserted in the timekeeping train of gears in order to lower the weight more slowly.

The weights of better class clocks are usually lead encased in polished brass. The weight of that for driving the time train of an 8-day clock is usually from 12 to 16 lb although some are as light as 8 lb. The weight for the striking train is about the same. At times the poundage is shown in the casting of iron weights and some have the makers' name on the top surround.

The action of the anchor escapement has already been described. Fig. 7 shows a common arrangement of wheels and pinions in an 8-day clock, with their names, for the going train. This is on the right, viewed from the front, an almost universal

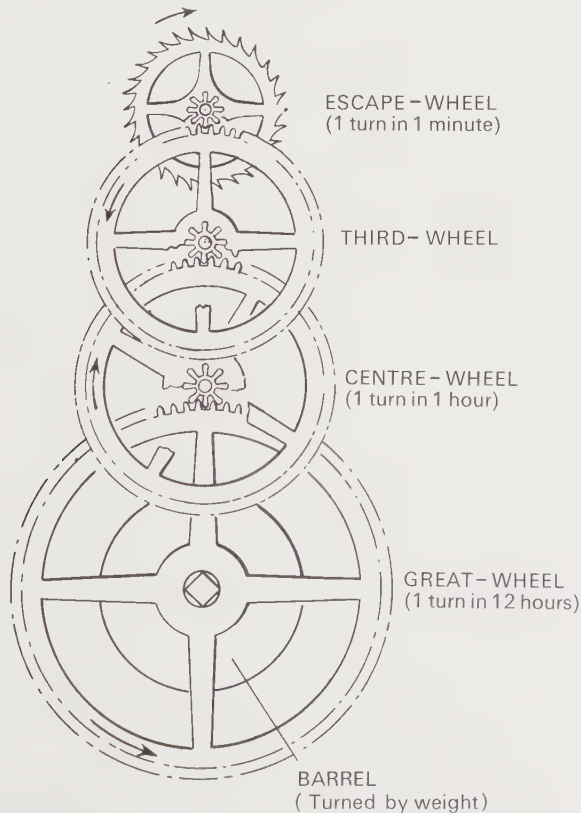
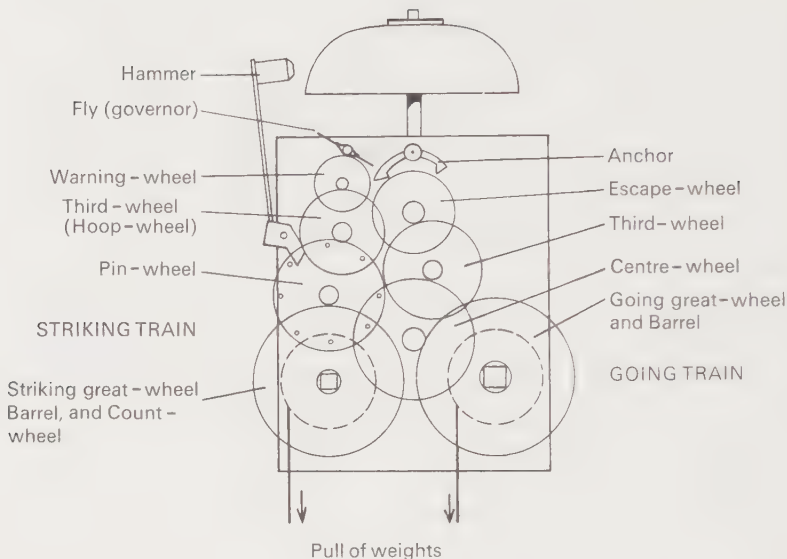

Fig. 8 Trains of a normal striking clock.



arrangement. Most longcase clocks strike the hours and some chime the quarters and play tunes as well. The striking train is placed on the left, as shown in Fig. 8 and is driven by its own weight.

The striking train in a movement is quite separate from the going train, and at every hour a pin projecting from a wheel in the going train that turns once an hour (the hour-wheel) lifts a lever. As the lever drops it releases the striking train to strike the appropriate hour.

The timekeeping, or going, train was referred to as the 'watch train' in earlier days, the gears for striking being the 'clock train' since the word 'clock' means 'bell'.

The gut line which the weight pulls turns the going great-wheel once in twelve hours. This turns the centre-wheel once an hour. The minute hand is attached to this wheel. Next in the train of gears is the third-wheel, turning in seven and a half minutes

and finally the escape-wheel which turns in one minute and carries the seconds hand. The rate of turning of the escape-wheel is controlled by the anchor escapement and seconds pendulum, as already explained.

This train of gears, it will be noticed, omits the hour hand which turns round the dial once in twelve hours. It could be fitted to the great-wheel which turns at this rate; it is, in fact, in the longcase clocks known as regulators. This arrangement, however, means a separate chapter ring for hours. In all domestic longcase clocks the hour and minute hands are concentric. The hour hand is driven from the minute hand by a separate set of gears on the front plate giving a twelve to one reduction and known as the 'motion work' (see Fig. 9).

One important feature is still missing. In order to be able to set the hands without damage to the clock movement, a clutch is necessary. A simple and effective method is used. Instead of the minute hand being firmly fixed to the arbor of the centre-wheel (see Fig. 9), it is mounted on a tube round this arbor and the tube itself is kept friction tight to the arbor by a spring washer, usually a curved strip of brass with a hole in the middle.

If the hands of an old longcase clock are examined, it will be seen that they are kept in place by a small tapered pin. This pin also keeps the friction washer tight.

If the minute hand is turned by hand, it will turn the tube – called the minute pipe – to which it is attached and both will slip on the centre-wheel arbor without forcing it round. To the minute pipe is fixed the first gear-wheel of the motion work driving the hour hand. Therefore, when the minute hand is rotated by hand to set the time, it will also drive and set the hour hand correctly.

The seconds hand is ordinarily at the top of the dial, since it is attached to the escape-wheel, and has a small chapter ring of its own. Very occasionally the whole train of gears was arranged upside down, which brought the seconds dial to the bottom of the main dial and meant that the anchor escapement was 'upside down', working underneath the escape-wheel.

Occasionally, a longcase clock was fitted with a centre seconds hand – one concentric with the hour and minute hands. This needs, as is obvious, an extra train of gears to drive it (see Plate 19).

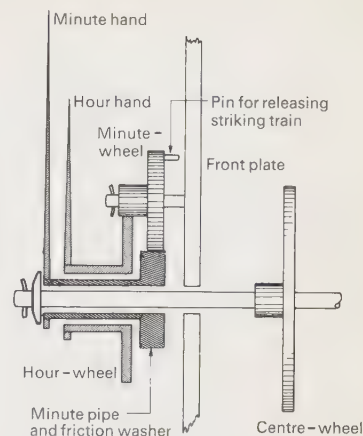

Fig. 9 Motion work of an 8-day clock. The minute-wheel has the same number of teeth as the minute-pipe (also called the cannon) wheel so that it turns once in an hour and a pin in it can release the striking train. The friction 'clutch' is not shown.



The wheels in Fig. 7 are set out in a straight line to make their action clear. In practice the arrangement takes up too much space and they are staggered (see Fig. 8).

The striking train has to have a device causing it to strike one, two, three, and more, in succession. In all longcase clocks before 1675 and in many into the eighteenth century, this was done by a count-wheel, a device very commonly, but mistakenly, called a 'locking plate'. It is a disc of metal with a series of slots around the periphery, shown in Fig. 10. The count-wheel turns while the clock is striking and an Γ -shaped lever above it is raised and dropped after every blow of the bell hammer. If this lever – called the locking lever – drops into one of the slots around the wheel, another mechanism comes into action to stop the striking train. If the lever just comes down on the rim of the count-wheel, the clock continues to strike. So the land between neighbouring slots determines the number of blows. There is no land for one o'clock, of course, because the locking lever just drops back into the same slot.

Some early high quality clocks had the hours engraved on their count-wheels.

In movements with a count-wheel it is possible to turn the hands too quickly when setting them to time or to forget to wind the striking train so that its weight runs right down until it rests on the bottom floor, with the result that the striking becomes out of sequence with the time shown by the hands. To set this right is simple. Remove the hood of the clock – in most cases it will slide forward – and examine the movement from the side. The count-wheel should be seen at once and its locking lever easily identified. If the locking lever is lifted momentarily by hand or with a pencil, the clock will strike the next hour. This can be continued until the last hour struck is correct according to the hands. The minute hand should not be near twelve when this is done.

The hammer is caused to strike by being lifted and released by a series of pins around the striking barrel, also to be seen in Fig. 8.

On early striking clocks, including lantern clocks, the count-wheel was outside the frame of the movement, but soon it was moved to between the plates of the clock with the main trains. So it is very rare to find a longcase clock with outside count-wheel

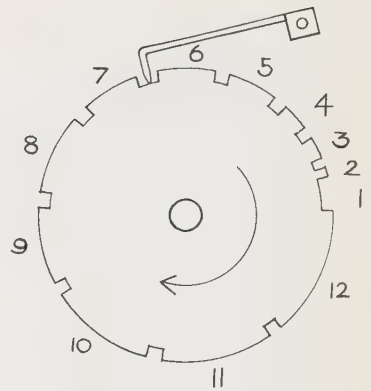

ABOVE

Fig. 10 The count-wheel on earlier striking clocks, which determines the number of blows struck on the bell.

OPPOSITE

Plate 19 Break-arch dial of the lacquered clock by a Colchester maker of about 1740 shown in Plate 31. It has a centre seconds hand, ringed winding holes and an engraved calendar aperture.

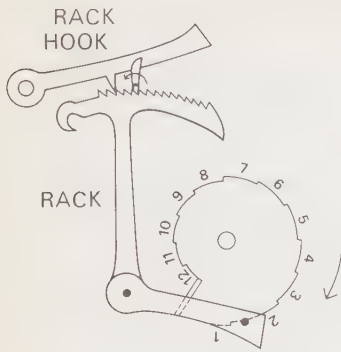

ABOVE

Fig. 11 The hour snail (turning in twelve hours) and levers which control the rack striking.

OPPOSITE

Plate 20 Magnificent lacquered clock in gold and other colours, signed Isaac Nickals of Wells, Norfolk. It is 8 feet 3 inches high and chimes, as well as having a centre seconds hand, and moon and tidal dials in the break arch. Remarkably, it will also repeat the last hour when required. The top subsidiary dials control repeating and chiming. The lower ones indicate the day of the week and month. The hood decoration later became popular in North America, where it was known as 'whales' tails'.

after 1720. For a short period, at first, the count-wheel between the clock plates was riveted to the outside of the striking great-wheel; afterwards it was placed between the great-wheel and striking barrel. Irish, Midlands, and Northern makers preferred a sequence of pins on the striking great-wheel to a count-wheel, the action with the locking lever being the same, and continued to employ this system until about 1800.

One of London's colony of clockmakers in the seventeenth century, Edward Barlow, invented a form of striking that, gradually coming into use from about 1676, entirely replaced the count-wheel on longcase and other domestic striking clocks and is manufactured in millions yearly today.

The invention is called 'rack striking'. The rack is an Γ -shaped lever except that the top bar is the arc of a circle and has ratchet teeth cut in it. When the clock is about to strike the hour, the rack is released and the lower end drops on a cam (called a snail because of its shape) that determines the number of blows on the bell. While the clock strikes, the rack is wound back by a rotating 'gathering pallet', which counts the number of blows. Each tooth represents a blow on the bell, so that the cam allows the rack to drop to a point where the number of teeth that have to be wound back represents the hour. The cam turns with the hour hand (see *Fig. 11*).

At first the rack was positioned between the plates like the locking plate, but it soon took the opposite course from its predecessor and was placed outside, but on the front plate under the dial and not at the back of the clock. This occurred about 1720.

Not all longcase clocks employed rack striking even late in their history. Locking plates continued to be used on 8-day clocks, particularly by makers outside London, until well into the eighteenth century. Makers of the popular 30-hour longcase clock continued to employ locking plates right into the nineteenth century, when the longcase clock began rapidly to lose its popularity.

One advantage of rack striking is that it can be made into a 'repeater' with no difficulty, so that the last hour struck can be repeated at will by pulling a cord, a valuable feature at a time when matches had not been invented and the time was needed in the dark. But repeating work is extremely rare on longcase clocks because they were not intended for bedroom use (see *Plate 20*).

The striking of a clock is released by a pin on the minute-wheel turning once an hour which lifts a lever. It does this a minute or two before the hour, which allows the striking train of gears to start running. The train is held up again almost immediately. This preliminary release is known as 'the warning' and can be heard on a striking clock before the hour. Exactly at the hour, the lever lifted by the pin drops again and the striking starts exactly on time. The purpose of the system, French in origin, is to provide accurate timing of the striking. The actual locking of the striking on an 8-day clock with a count-wheel is by a hoop-wheel – the third wheel in the striking train, which has a narrow rim of brass with a gap in it (the hoop) soldered to the side of the wheel just below the teeth. A hooked lever drops into the gap just after the warning starts, to hold up the train. The lever is raised to release the train.

The hoop is replaced by a pin in rack striking, the hoop-wheel being renamed the 'pallet wheel' because on the end of the same arbor is the 'gathering pallet' which rotates to wind up the rack.

The first longcase clocks just struck the hours. A few sounded every half hour also by a single blow on the same bell or another smaller bell with a higher note.

To run for a week, the striking train has to store enough energy for 1,092 blows on the hour bell. In a month clock it becomes a problem to store enough energy for about 5,000 hammer blows without a very heavy weight and additional gearing. Some clock-makers, including Joseph Knibb and Daniel Quare, solved the problem by employing Roman striking, which reduces the number of blows struck to less than half. They fitted two bells, one of higher pitch indicating I and the other of lower pitch indicating V. If a light dot indicates the higher pitched bell and a heavy dot the lower, . . . is three o'clock; . . is four; • is five; • . is six. The Roman ten, X, is sounded by two blows on the lower bell, therefore . . . is IX or nine, and so on (see Plate 18).

A few other makers adopted Roman striking, but their clocks are rare today and change hands for high prices.

Chiming or quarter striking was unusual on early longcase clocks although one of about 1680 by John Fromanteel has it. He used the ting-tang, which is the earliest known form of striking



and was used on public clocks for centuries before. Two bells are employed in addition to the hour bell – a higher one (ting) and a lower one (tang). Fromanteel struck the two together for hours. Some clocks that chime the quarters as well as striking need a third train of gears and a third weight. The chiming train is placed on the right of the time train. In the ting-tang a separate locking plate controls the chiming train. At quarter past an hour a single ting-tang is sounded; at half past, ting-tang, ting-tang; at a quarter to, three ting-tangs; and before the hour, four of them. A movement with ting-tang and hour bells is shown in Plate 78.

Chiming trains with six or eight bells followed the ting-tang and were not uncommon by the beginning of the eighteenth century. Various melodies were favoured, but the most popular scheme was to run through the scale, once for the first quarter, twice for the second quarter, and so on (see Plates 20 and 21).

Because a chime does not indicate which hour has passed, a system known as ‘Dutch striking’ was evolved. Again two bells, one a high note and the other with a low note were employed. The hours were struck on the large bell. The half hours were indicated on the small one by sounding the *next* hour, so at half-past three, for example, there were four blows on the higher bell.

A full-scale system of quarter and hour striking called ‘grande sonnerie’ was applied to a few longcase clocks for a period of about thirty years at the beginning of the eighteenth century. A grande sonnerie clock strikes the previous hour after sounding the quarters. For example, at 9.45 the clock would chime three quarters, then strike nine (see Plate 22).

The Westminster chime, which employs four bells, was not incorporated in early clocks, as it was not devised until 1788 or later, when Dr Crotch adapted the melody of the fifth bar of Handel’s aria, ‘I know that my Redeemer liveth’, from the *Messiah*, for the Great St Mary’s Church clock at Cambridge. It is called the Westminster chime because a modified version was used for Parliament’s ‘Big Ben’ clock, which was not erected until 1859, and undoubtedly made it really popular.

Musical trains were occasionally built into longcase clocks from about 1770. The musical clock differs from the chiming clock in playing a tune or tunes after striking as entertainment, not specially to mark the time. Some have only six or eight bells

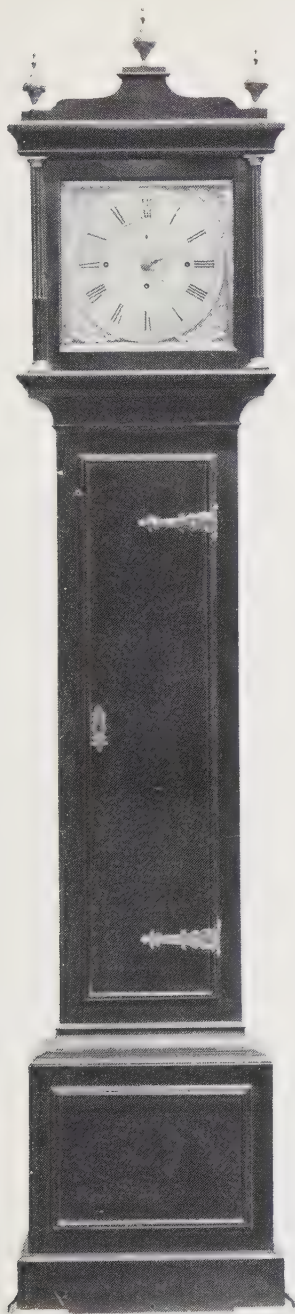

FAR LEFT

Plate 21 A chiming clock which is a rarity because of its three-legged gravity escapement. It was made by John Evans of 89 Mount Street, London. This form of escapement provides a constant force to impulse the pendulum and therefore is of high precision. Lord Grimthorpe invented a three-legged gravity escapement for Big Ben a few years before 1858.

LEFT

Plate 22 Edward East made this marquetry cased clock in the later seventeenth century. It has grande sonnerie chiming. The barley-twist pillars to the hood have elaborate, finely finished and gilded capitals.

OPPOSITE

Plate 23 Break-arch dial with no half-hour or quarter-hour marks. In general these date after 1750, although some from London makers may be a little earlier, as this by John Ellicott may be. There is a strike/silent control in the arch.

and the range of tunes was therefore limited; others have a dozen or more bells and a means of selecting one of seven tunes – one for each day of the week (see *Plate 96*).

As the musical performance is extensive, the clock needs another weight and train of gears to drive a barrel with pins in it (like that in a music box) which operates the bell hammers. As chiming was often incorporated as well, the clock had to be provided with four trains of gears, for going, striking, chiming, and music.

The time when the music plays depends on the design of the clock. Some are arranged to strike the hour normally, then play a tune after the hour.

The necessity for another train of gears was avoided by some makers who omitted the chime, and caused the clock to play a tune every three hours – at 3, 6, 9, and 12 o'clock – after striking.

The owner of a clock that chimes and plays a tune every quarter of an hour of the day and night is likely to end his days in a mental institution. Fortunately, musical clocks normally have a two-position lever on a subsidiary dial which can be moved to 'music silent'. A subsidiary dial with a 'strike silent' position is also common on chiming clocks (see *Plates 23* and *64*). The tune indicator is often in an arch above the dial. A lever of the tune indicator moved to the tune selected, shifts the chiming barrel axially, so that a different set of pins comes into operation. This again is similar to a tune-change mechanism in a musical box, where the action can be seen, as the top is usually of glass. A clock playing seven tunes has a thousand or more operating pins in its musical barrel.

A striking, chiming, or musical train needs some form of 'escapement' to control its speed, otherwise the driving weight drops rapidly and the bells are struck rapidly one after the other. To produce measured blows, each train drives a small, fast rotating fan, known as a fly, which acts as a speed governor. This, in the longcase clock driven by weights, gives an always constant and stately strike or chime; spring-driven clocks are apt to start in a hurry when the spring is wound, and end with tired blows when the spring is almost run down.

Chimes are not always on bells. Some nineteenth-century versions play on tubes hung in the back of the case.

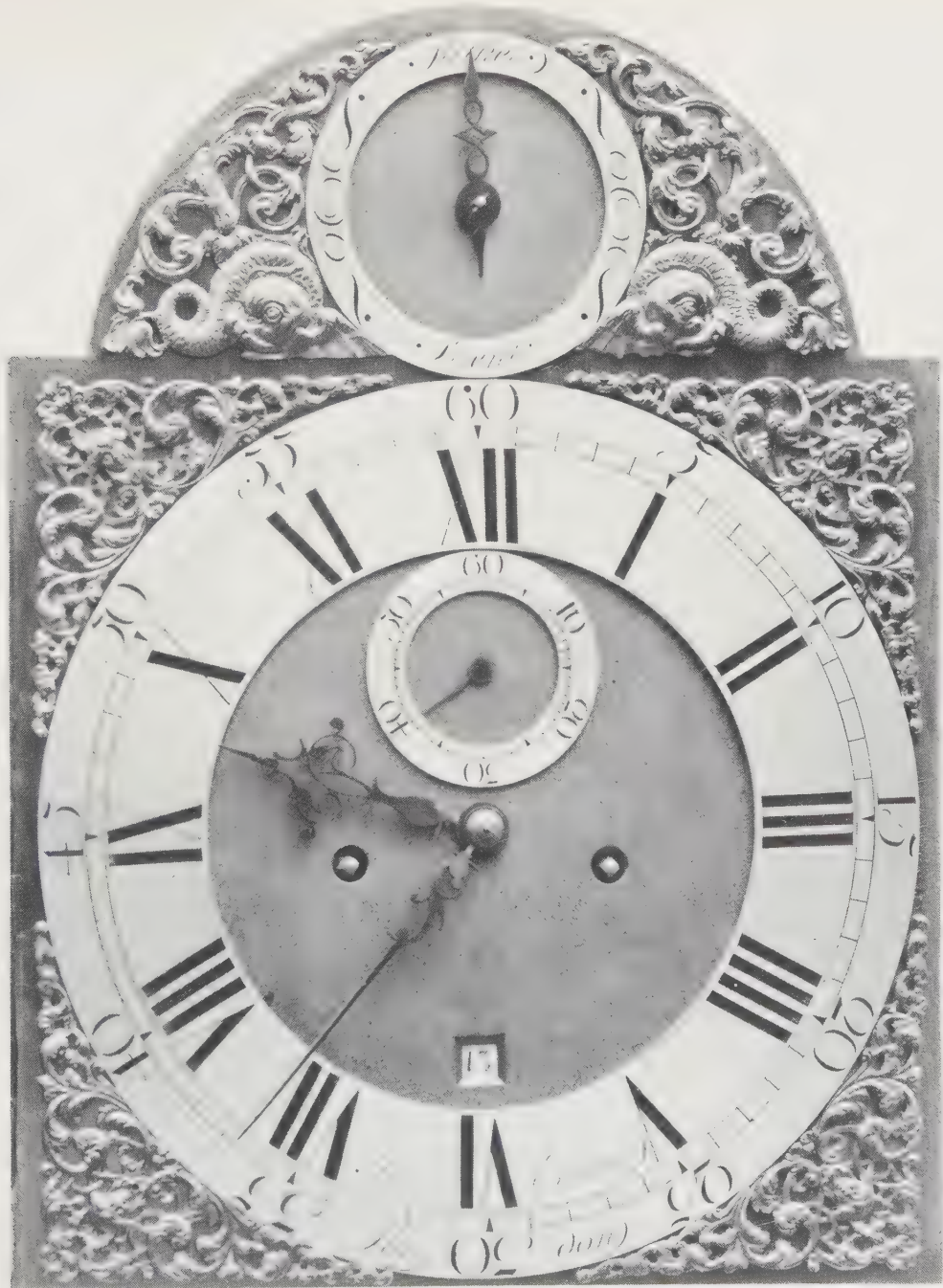



CHAPTER FIVE

SHAPES
AND
WOOD
FOR CASES

OPPOSITE LEFT

Plate 24 A rising hood, which was used on the early, shorter clocks of the seventeenth century, such as that in *Plate 24*. It slid up the backboard of the case, which fitted into the grooves that can be seen here. The hoods of the taller clocks that followed slid forwards and also had a door in the front for winding and setting the hands.

OPPOSITE RIGHT

Plate 24 An early longcase clock with ebonized case, architectural hood, and long panelled door by John Fromanteel. It has a long pendulum and was made about 1680. The architectural style began to disappear when the long pendulum took over from the short one.

Although a tall case of wood made as long ago as 1570 is still in existence in the Kremsmunster Monastery at Linz in Austria, this and others like it were exceptions and the long case did not become general until after it was needed to enclose the seconds pendulum as well as the weights.

Wooden clock cases were extremely rare before the pendulum came into use in 1658, and it may be true that the idea of a wooden case was also introduced from Holland by John Fromanteel (see *Plate 24*).

When the English style of longcase clock was introduced, its popularity grew rapidly and twenty years later English makers dominated those of all other countries. It had a run of over 150 years of popularity and, to give a general picture, its history is here condensed into two paragraphs.

From 1660 to nearly 1700, makers followed their own ideas both in movements and cases, but during those thirty odd years a main stream of design gradually emerged. London makers led the way and their production of longcase clocks outnumbered those of spring-driven bracket clocks for many years, but the long case declined in favour from about 1725 to 1750, and fewer and fewer were made. London makers concentrated on portable clocks and, even after 1750 when the longcase came into favour again, they only made more sophisticated ones to special order.

This left the field open to provincial makers and, after mid-eighteenth century, country production grew rapidly until a huge output was reached in centres all over the country and par-

ticularly in Lancashire and Yorkshire. Most of these clocks date after 1760. During the last twenty years of the eighteenth century, the design of the longcase clock was considerably influenced by rising prices and materials. Matted and silvered brass dials disappeared in favour of painted sheets of iron. Design was static although some makers dredged up a few themes from the past. Finally most longcase clocks had movements made in factories, and supplied to 'clockmakers'. Towards mid-nineteenth century, production declined rapidly in the face of competition, particularly from small American clocks made by machine and imported in large numbers at a few shillings each from the 1840s, and from the German Black Forest industry also, from the 1850s.

For about the first ten years of their existence, longcase clock cases followed architectural styles. The case was narrow and the top of the hood was shaped like a ridged roof. The movement had a short pendulum at this time (see Plate 11). When the long pendulum was introduced it heralded a change in the design of the case; casemakers began to leave the classical design and follow a line of their own. Plates 11 and 25 show architectural designs.

Little is known of the men who made clock cases. They did not

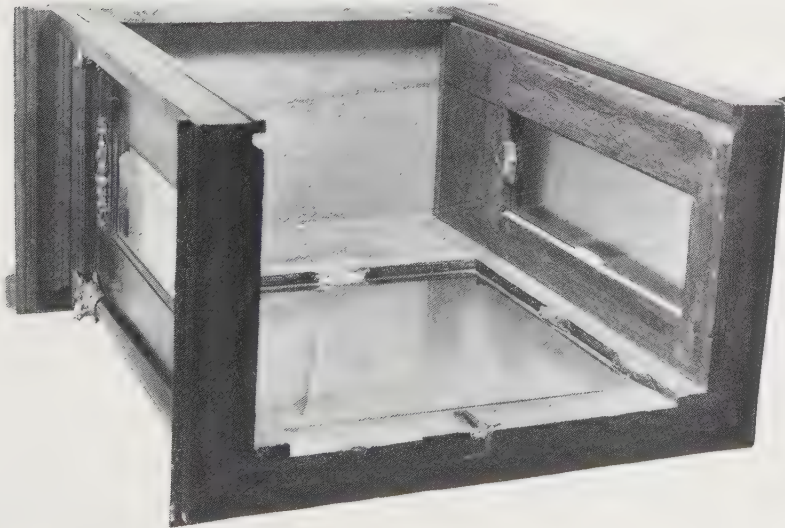



sign their work as did some watch casemakers. The name on the dial was always that of the clockmaker, and he was normally more of a work master than actual maker. Parts of a clock case are shown in Fig. 12.

The first cases were made of oak with a veneer of ebony. The trunk was panelled and the door was long and narrow, often with three panels, the central one being much smaller than those above and below it (see Plates 11 and 25).

The base was a little wider than the trunk and, during the seventeenth century, usually had feet (see Plates 18, 22, and 24), although these have in most cases been removed from examples that still exist, and replaced by a narrow skirting standing directly on the floor.

The hood of the clock, enclosing the movement, lifted upwards for winding and is known as a 'rising hood' (see Plate 24a). At first it had a fixed glass and no door. The total height at this time was about six and a half feet or less, so the owner could raise the hood without difficulty. It was released by opening the case door which allowed a 'trigger', known as a spoon, just inside the case at the top, to move forward. The hood could then be raised, being grooved to slide up the back board of the case. A spring catch held it clear of the winding holes in the dial. The arrangement prevented any unauthorized interference with the hands, because the door in the trunk of the clock could be locked and when closed it pushed the iron spoon back to lock the hood.

Another feature of all longcase clocks before about 1700 was a convex moulding under the hood, where it joins the trunk. This is an almost positive feature for identification of an early clock. (See Plates 16, 18, 22, 24, 25, and 26 of early clocks and compare them with later ones, but see Plate 9.) After the end of the century, the concave moulding became universal. The simple concave section is usually relieved by steps, but the general form is clearly concave.

The long pendulum of 1671 needed a wider trunk than the short pendulum because it swung there; this encouraged the increase in size of the whole clock. Heights grew to seven feet and over. The dial also increased in size from about eight and a quarter to ten inches. Some of the short pendulum clocks were exceptionally narrow as shown in Plate 25.

The rising hood remained, even with later clocks, until nearly

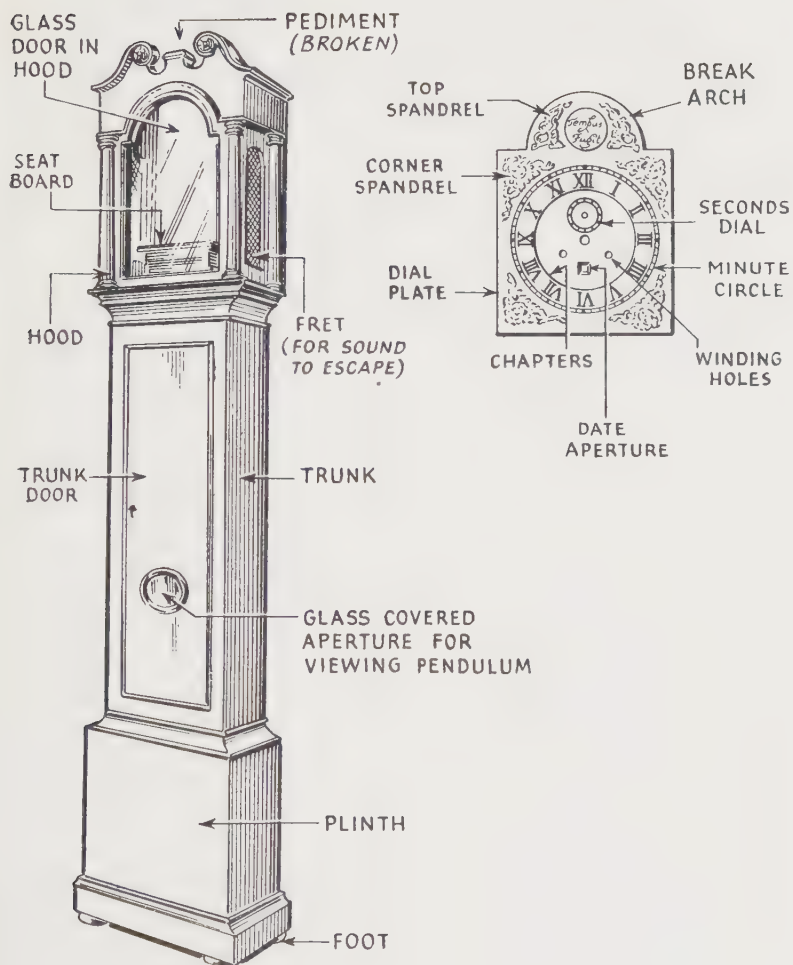

OPPOSITE
Plate 25 A very early longcase clock with ebonized and panelled case with architectural hood. It is 5 feet 11 inches high. The maker, Samuel Knibb, worked closely with Fromanteel in London and died about 1670. He was a cousin of Joseph Knibb. The movement has a short pendulum, but with an anchor escapement.

LEFT
Fig. 12 Parts of a longcase clock and dial. (Drawing by courtesy of the British Horological Institute Correspondence Course.)

1700, but gave way entirely to a more convenient arrangement of a hood that slid forward for removal to give access to the movement. A glass door in front of the dial was also provided so that the hands could be adjusted without removing the hood. The sliding hood continued until the longcase clock eventually went out of fashion. This hood was often provided with a lock, although not on later, and more popular productions.

Curiously, there is a longcase clock which is attributed to A. Fromanteel about 1658, with a hood that slides forwards. It is about seven feet tall. Nevertheless, almost every early maker preferred a rising hood for clocks that were less than this height, as most were during the earliest period.

Some early hoods had pillars or columns with beautifully finished gilded metal capitals – the ornaments at the top – made up of as many as twenty separate but assembled pieces of acanthus leaf design. The foot of the column was also of metal but plainer. The door hinge was on the top and bottom of the right-hand pillar. Later capitals were in one piece and occasionally cheaper clocks had wooden capitals painted gold.

Pillars at first were plain; some were free standing (see Plate 26a) and others were a combined part of the hood itself. Very early clocks usually had quarter pillars at the back of the hood also (see Plates 15, 18, 22, and 26). The back of the clock sometimes just had ‘splats’, thin strips of wood, sometimes with a shaped profile at the sides of the rear of the hood. (See Plates 31 and 82 with quarter pillars and Plates 28 and 29 without.) The spiral or Jacobean pillar came into fashion very quickly after the invention of the long case and persisted until about 1700, after which the plain pillar regained its popularity, usually with plain gilded metal capitals. Fluted pillars of Corinthian style were also employed by casemakers; after mid-eighteenth century the fluting was sometimes only in the front of the column. Free standing pillars became popular again in Yorkshire and other clocks in the later eighteenth century (see Plates 57 and 80).

A gilded metal decoration was applied at times to the earliest clocks in the centre of the pediment (the top of the hood). It was often a ‘swag’ – a drapery held at each end or a festoon of flowers.

The top of the hood became flat or domed after the first architectural period. A domed hood is shown in Plate 18. The flat



FAR LEFT

Plate 26 A beautiful floral marquetry case for a clock with domed hood by Charles Gretton, London, which is 7 feet 7 inches high. Note that all clocks prior to 1700 can usually be dated by the convex moulding under their hoods.

LEFT

Plate 26a Much attention was paid to the mahogany case of this clock by R. Henderson of Scarborough, dated about 1740. There is a moon face in the arch, but it is a decoration. The pagoda hood has reeded pillars with elaborate capitals. The inlays are of ivory and boxwood.

OPPOSITE LEFT

Plate 27 The Japanese lacquer case of this clock by Philip Abbot, London, made about 1750, has a red ground. The pagoda top was popular for lacquered clocks. Note the glass in the side of the hood that may have replaced a broken fret. Frets were used to let out the sound of striking.

OPPOSITE CENTRE

Plate 28 Another wide Yorkshire case, made for the prestige-conscious buyer. These mahogany cases were excellently made although the proportions were ungainly. The height is over 7 feet 9 inches and the clock was made between 1840 and 1850 by Gunter of Huddersfield.

OPPOSITE RIGHT

Plate 29 Eight-day walnut cased clock by a Colchester maker, John Wayland, with an 11-inch dial that has an elaborately engraved centre. It was made about 1705, but the earlier convex moulding under the hood was retained by the country maker, as fashions were slower to change.

top persisted well into the eighteenth century, but more current was the domed top which became more elaborate on important clocks, and often had three metal ornaments in ball, flambeau (flame), or other form (see Plates 12, 16, 26, and 54). Cresting often decorated the top of the hood (see Plates 20, 22, and 28).

Another feature of seventeenth-century hoods was a glass window in each side so that the movement could be seen (see Plate 27). The idea was continued in some later clocks. Frets were also used to let out sound (see Fig. 12). Some frets were of gilded brass and others of wood. The frets were invariably backed by coloured silk. It has been suggested that glass sides were early replacements for broken wooden frets. Frets continued for fine clocks through the eighteenth century.

Then on some clocks the arched top to the hood was cut in half and reversed, as it were, to provide hollow sides. This is called the pagoda top and is typical of the Chippendale period of furniture, being made, from say 1740 for about fifty years. The cases of such clocks were often japanned (see Plate 27).

After the break arch dial had come into common usage, casemakers copied the shape some years later for the hood top also (see Plates 20 and 30).

Finally – as far as original designs were concerned – a scroll form, also called ‘swan’s neck’ or ‘horned’ (see Plates 28, 40, 132, and 140), was popular for the top of the case towards the end of the eighteenth century and used prolifically by provincial makers. It is a ‘cresting’, often no more than carving, mounted in front of the hood of a flat or broken-arch top. Cases in mahogany with it are often referred to as Chippendale, although few followed Chippendale’s particular designs for long cases, which included a number with fretted work on the tops of the hood and one that was tapered outwards towards the top, a style the French developed. One Chippendale style case is shown in Plate 95.

In the nineteenth century, hoods were copies of earlier periods. The flat top, but sometimes with ornaments, the break arch, and even the first architectural style reappeared.

A circular window in the door to check the going of the pendulum was another early feature, although whether or not the window was to check that the clock was going is a moot point. The loud tick of the early verge escapement or the seconds hand



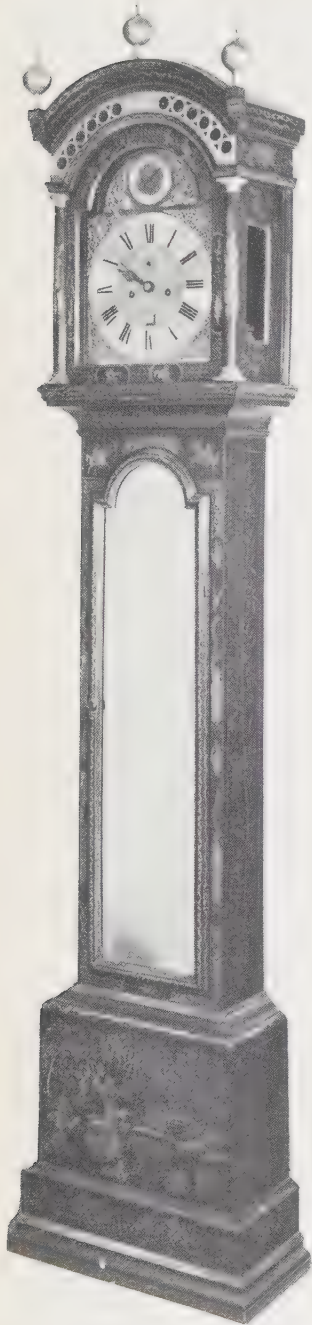

used with the later anchor escapement were better indications. More likely it was an outward indication that the clock had the superior long pendulum or was just a form of decoration. The glass was round or oval. Sometimes it was plain, but a bull's-eye glass was also fitted (see Plate 29). Glass at the time was made by blowing a bulb and cutting off the end so that a cup was left. The cup was spun so that the glass formed a rough circular sheet for cutting into window panes for leaded lights. The centre thick portion which was attached to the blow-pipe is the bull's-eye that is sometimes used in clock doors – although it served more as a decoration than a useful feature. A few earlier eighteenth-century long cases had a door panel of Vauxhall mirror (see Plate 30).

It was mentioned in Chapter Three that clockmakers experimented with pendulums longer than a metre, in the belief that they might be more accurate. Some longcase clocks were made with one and a quarter seconds pendulums, which were about sixty inches long and hung almost to the bottom of the case. There might be a circular window in the base of the case, and also a hinged or sliding door, as well as the normal door in the trunk. As it was difficult for the owner to get on his hands and knees to regulate the pendulum from the bottom in the orthodox way, a means of regulating its length from the top of the clock by a vernier regulator was provided.

The general size and width of the case increased through the years. The earliest longcase clocks – now, alas, very rare for an ordinary collector to find – are slim, only six to six and a half feet tall, and well proportioned. Then the trunks grew wider, the hood and base bigger, and the clock taller, to seven feet and more. Some special ones went up as high as nine feet tall. Extremely rare are grandmother clocks – around five and a half feet tall – except in North America. Only about six or eight of the early 1680 to 1700 period are now known. Some were also made from about 1780 to 1800. They have seconds pendulums.

In general the trunk width was about half an inch or so wider than the dial in the best cases, but increased until at the end of the eighteenth century. It was sometimes much wider.

The door in the trunk – at first panelled as mentioned, then surrounded by beading (see Plate 22) – remained rectangular, i.e. with a flat top, during the seventeenth and first quarter of the

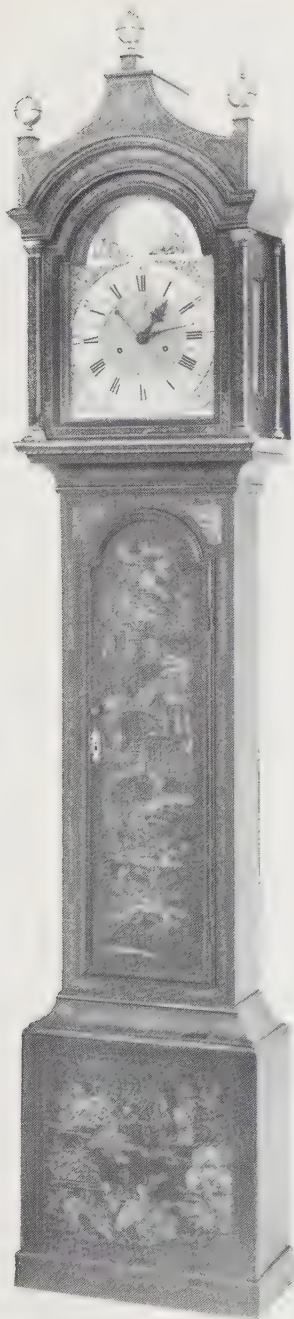

OPPOSITE

Plate 30 Green lacquer longcase clock by William Webster, London, of the George I period, with the unusual addition of a mirror in the door. The hood is arched, repeating the break arch of the dial. The hand and dial in the arch are to regulate the pendulum.

FAR LEFT

Plate 31 Lacquered 8-day clock by a country maker, produced about 1740, with the popular pagoda top. The 12-inch dial has a quite rare centre seconds hand. The clock is signed Cooper and Hedge, Colchester. *See also* Plate 19.

LEFT

Plate 32 A mahogany cased clock with an unusual dial. Although of brass, it has a painted 'Jacobite farewell' scene on the zone. In the break arch is a moon dial. The hood cresting is a form of swan's neck with roses at the ends. The clock appears to have been made in the late eighteenth century.



eighteenth century. After that the tops of doors were often shaped to reflect the design of the hood in a broken arch, or arch shape (see Plates 20, 27, 30, and 31). After about 1750, a wavy top edge was introduced with a bevelled edge to the door (see Plate 32). Because the trunks were narrow, the doors on the earliest clocks look longer; in fact, nearly all take up most of the area of the trunk. Later on, in the eighteenth century, the door was sometimes appreciably smaller than the frontal area of the trunk, particularly in provincially-made clocks.

The earliest cases had ebony veneered on oak for the case and this did not outlast the architectural period. Stained pearwood veneer imitating ebony was an alternative. Solid oak was also employed, but not often for high fashion clocks, and then usually outside London.

A veneer is a very thin slice of wood cut at that time by hand. It saved expense with rarer woods and with some also resulted in beautiful figuring. Early casemakers could only veneer certain woods and then usually in small sheets which had to be carefully selected and fitted together.

During the last quarter of the seventeenth century a new wood was introduced, that of the olive tree. It was relatively hard, which made it durable, and it became very popular for long cases. Olive wood could be veneered to produce attractive rings reminiscent of oyster shells and the veneers were therefore often called 'oyster pieces'. As only relatively small pieces of veneer could be cut, they were used in strips and arranged so that the oyster patterns were symmetrical. An oyster case is very fine and instantly recognizable (see Plate 33).

Walnut veneer also has a scrolled pattern, although not in 'oysters' and could be book-matched, i.e. arranged in symmetrical patterns. It is known as burr walnut (see Plates 17 and 34). The convenience of being able to lay veneer in any direction without difficulty encouraged its use for edging, particularly when cut to give a straight grain or banded appearance. This naturally led to the idea of making patterns of different coloured wood veneers fitted together.

Decorations appeared in the veneer of long cases at an early time. The earliest were stars made up of alternate triangular veneers of black ebony and yellow boxwood inlaid with the base



OPPOSITE
Plate 33 Oyster pieces, a form of veneering in olive wood that is exceptionally attractive and was popular in the latter seventeenth century. Here it is combined with some marquetrie in the case of a clock by Thomas Tompion.

FAR LEFT
Plate 34 Fine burr walnut case of a clock by W. Skikelthorpe of London, which is 7 feet tall. It has a strike/silent control in the arch and was made before 1750.

LEFT
Plate 35 A longcase clock of about 1703 by Thomas Tompion in a case veneered in mulberry wood.

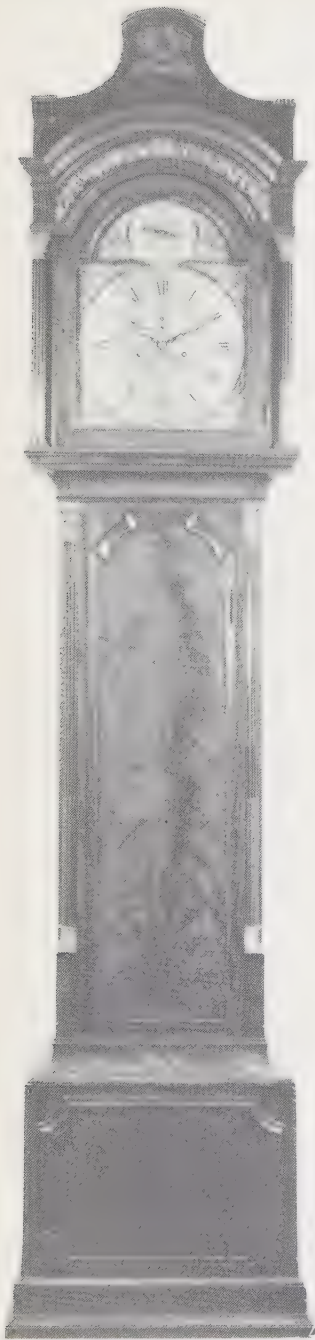

olive wood veneer. The simplest form of such decoration, in geometrical patterns with straight edges, is known as 'parquetry' (see Plate 137). The more elaborate in all-over forms and complicated designs is called 'marquetry'. The simple stars or corner 'fan' emblems, which may have originated in Holland, developed into elaborate and intricate designs – some of remarkable complexity – which were introduced before the eighteenth century, increased in popularity during the early part, and finally went out of fashion after mid-century (see Plates 12, 16, 22, 26, 54, and 114). Sometimes holly wood and ivory dyed green were used as an alternative to boxwood, but still used with ebony. The all-over patterns, often with floral or flower and bird motifs, later developed into scrolled patterns, called 'seaweed marquetry' (see Plate 54).

At the same time as marquetry was in demand, the lacquered case came into favour, following a fashion in furniture generally, although the lacquered clock case seemed to retain its popularity for a longer time. Most lacquered cases, however, were made in the first quarter of the eighteenth century. They differed in another way from other cases because they were normally made of softwood, whereas the carcasses of most other long cases were of hardwood, oak (see Plates 20, 27, 30, 31, and 75). Softwood was used too for the carcasses of some later walnut cases. The reason in both instances was probably because oak tends to change its shape more with humidity changes and crack the lacquer or veneering.

Lacquering, or 'japanning' to give its contemporary name, bore no resemblance to what is commonly called 'lacquering' today, although some true lacquering is still carried out by Eastern craftsmen in England. The wood was coated with several layers of a ground made from a white powder. On this, decoration was built up with coloured 'paste' so that it was in relief. The whole was then given a coat of transparent varnish.

Colours most common in lacquered work are a black ground with other colours – blues, reds, greens, and gold – forming the pattern. Very occasionally the ground was blue, green, red, or very rarely cream or buff. The art originated in the East and clock cases, or parts of them, such as the oak doors of trunks, went abroad to be treated. Designs naturally have a strong oriental

flavour. The craft of lacquering was also followed in England and Holland and craftsmen imitated oriental designs, so it is not easy to identify the imported and home products. In no case has original lacquering withstood the years well and there are few clock cases today without whole areas of the surface flaked off through the attrition of damp, heat, and sunlight. Over-restored cases are seen not infrequently and occasionally one that has been stripped and painted black.

The lacquer period was from about 1700 to 1760. There were some small revivals of interest in lacquering in later periods and some cases were renovated.

Undecorated burr walnut, and very occasionally mulberry veneer (Plate 35), continued in favour from about 1690 to 1760, but after the 1720s owing to a change in import regulations, cabinet makers began to employ many 'new' woods. The chief of these was mahogany, which made a huge impact on all quality furniture making. So-called Spanish mahogany was the first choice, a heavy close-grained wood of deep brown colour. Cuban mahogany followed, being similar although lighter in colour and with a wavy grain.

Both were largely superseded before the last quarter of the eighteenth century by Honduras mahogany, also called bay wood, which was lighter in weight and reddish-brown in colour.

Japanning, and in particular walnut veneering, which lasted into the late eighteenth century, were so popular for clock cases that the introduction of mahogany affected them later than other furniture. Mahogany was the favourite wood for higher quality furniture by 1750, but not until ten years later for clock cases. Mahogany was difficult to veneer at the time and was often used in the solid. When it was veneered, the veneers were applied on a carcass of poorer quality mahogany for the best clocks and regulators. A grain pattern known as 'Cuban curls' and another called 'feather' were popular. Curls occurred in wood where a branch joined the tree trunk (see Plate 36). Mahogany retained its popularity until the long case went out of fashion. Some of the late and large Yorkshire cases had mahogany veneers laid in a form of parquetry (see Plate 28).

There was also a vogue for carved oak long cases at a later period. It has been suggested that these cases (see Plate 37) were

OPPOSITE

Plate 36 Mahogany cased clock by William Poulton and Son, London, 'watchmaker to His Majesty the King of Spain'. It is 8 feet 2 inches high and has grooved pillars with capitals on the front corners of the trunk, as well as on the hood. In the arch is a strike/silent control.

RIGHT

Plate 37 A carved oak case of about 1825, enclosing an 8-day clock with silvered dial by Joseph Banister of Colchester. Carved cases had a spell of popularity at the same time as carved Victorian furniture. The dial is shown in Plate 56.

FAR RIGHT

Plate 38 Occasionally the oak carving went to extremes, as in this case.



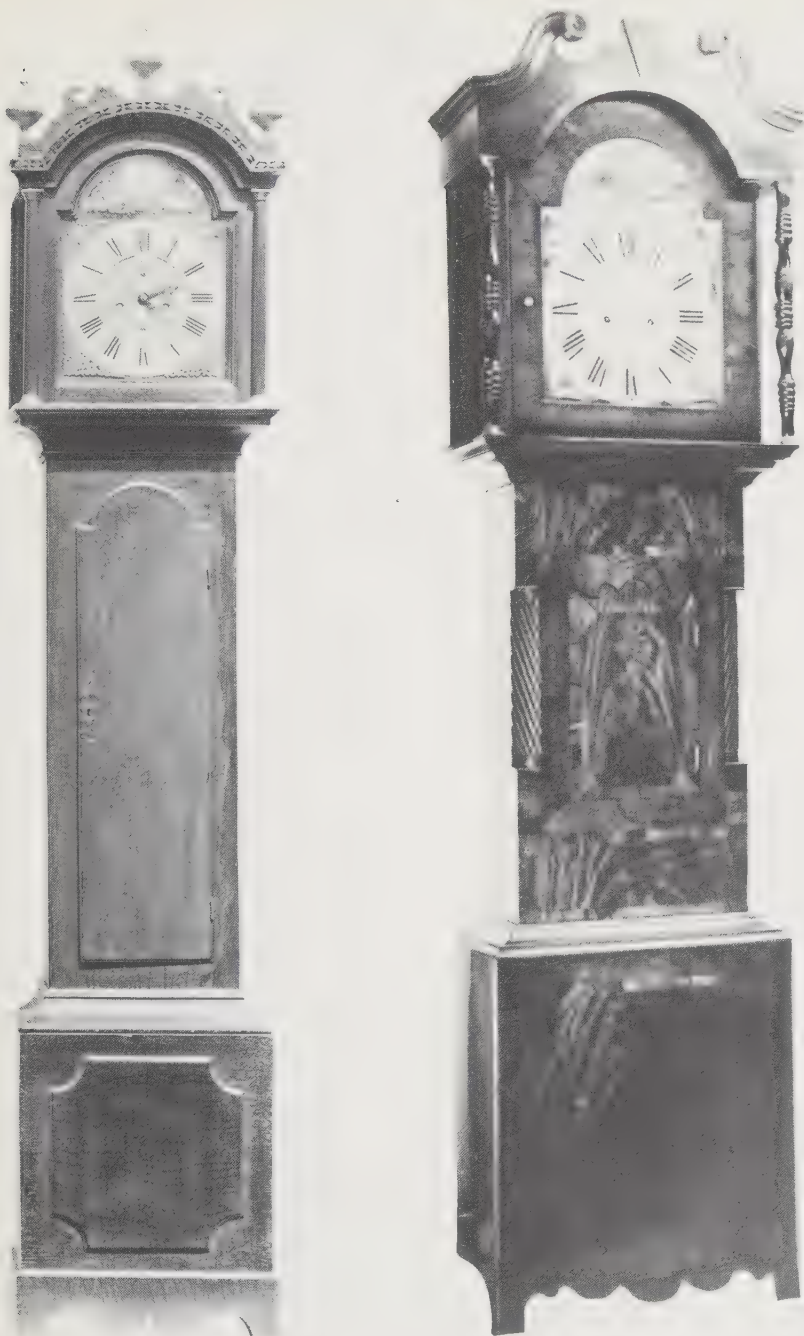

FAR LEFT

Plate 39 Oak cases were made throughout the longcase clock period for precision clocks as well as for thousands of country clocks. This houses a clock by Joseph Williamson, an important London maker of the early eighteenth century.

LEFT

Plate 40 A wide Yorkshire mahogany cased clock with painted dial of about 1840 by Richard Snow of Pately Bridge. Note the typical short pillars in the front corners of the trunk. The height is about 7 feet 3 inches.

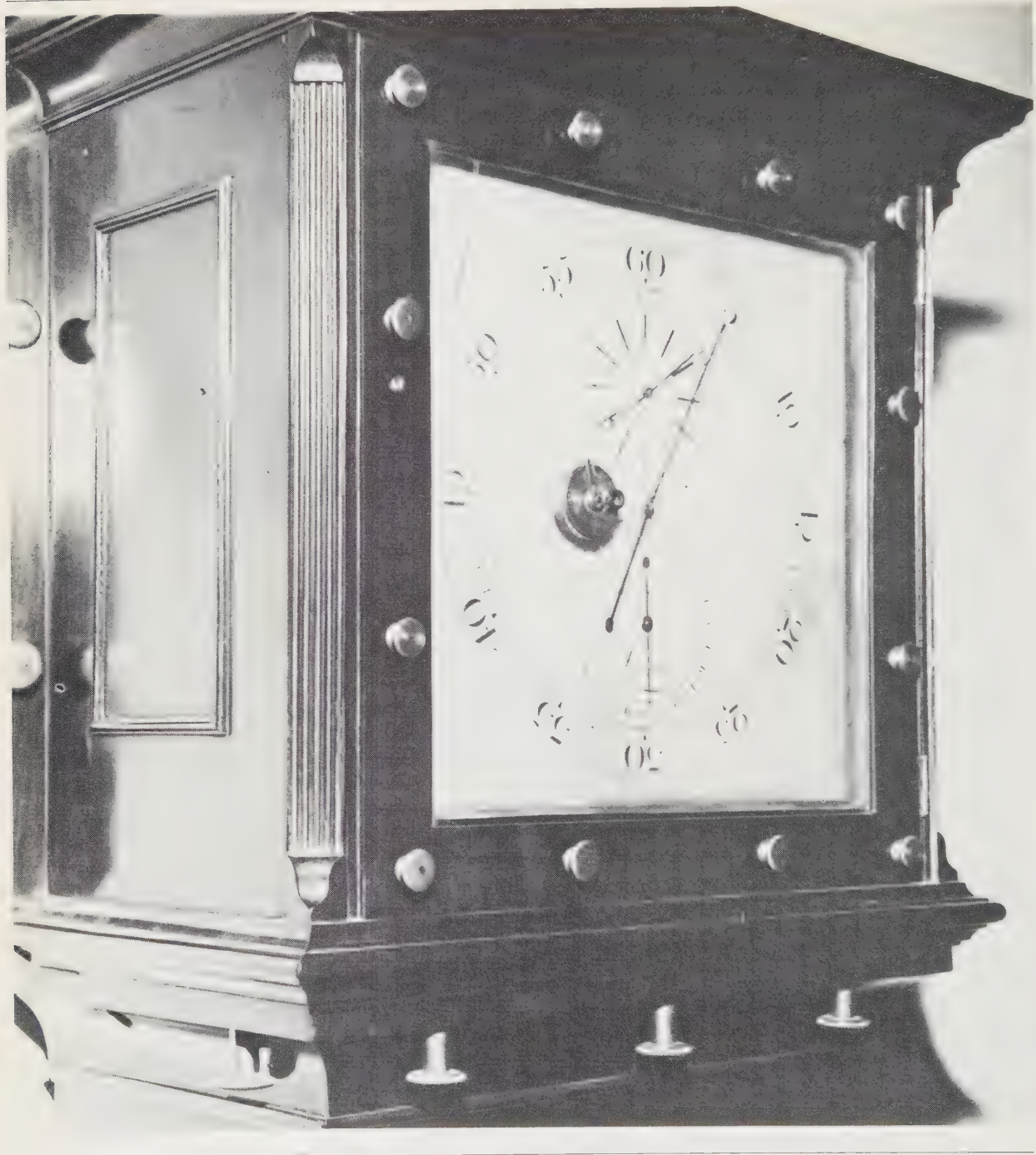

later constructions of the nineteenth century, perhaps made to replace original cases that had been damaged or disliked. Some have turned up in parts of the old British Empire, particularly India, and these cases may have been carved locally (Plate 38). It appears, however, that makers in Yorkshire and Lancashire supplied clocks in carved cases from about 1780 to 1810. These clocks have two common features beside the carving. The pillars on each side of the hood are of barley twist style and are free standing, and the splats at the back of the hood – side pieces providing extra width at the back – are tapered upwards instead of being parallel-sided or sometimes wavy-edged. At the end of the nineteenth century there was a great vogue for carved ‘Jacobean’ oak furniture. No doubt the clock suppliers followed this style. Some of the furniture pieces have ridiculously early seventeenth- or eighteenth-century dates carved on them.

Oak, as already mentioned, was used for the carcass of the clock, and overlaid with veneers or more exotic woods for the best-class work, particularly for the products of London makers; occasionally, however, solid walnut and more often solid mahogany was employed.

Throughout the eighteenth century, country clockmakers, and the top men, for their more popular and technical clocks, fitted movements into solid oak cases, for oak, being indigenous, was cheaper and easy to obtain (Plates 39, 71, and 82). An oak carcass was sometimes veneered with a better oak, such as pollard oak, which has an interesting pattern of grain, straight lines of dark dots with light wavy bands crossing them. The pattern can be seen in Plate 49. At times the oak had a simple inlay of walnut or box, or holly banding along the edges. Some had mahogany trim (see Plate 49).

Other lower priced productions had mahogany cases towards the end of the eighteenth century, both these and the oak cases of the time being fitted with movements with painted dials. From a few years before 1800 the mahogany often had simple inlays of shell or flower patterns in the centre or corners of the trunk door, the base, the top of the hood, and elsewhere (see Plate 137).

Clocks with 30-hour movements and hour hands only were in oak cases through the century, but from after 1700 some appeared in soft-wood cases, varnished or grained (see Plates 3 and 136). These continued to be made into the nineteenth century.

OPPOSITE

Plate 41 A regulator clock made by Thomas Earnshaw, High Holborn, London, the famous chronometer maker of the late eighteenth and early nineteenth century. He made only three clocks, all regulators. This one was for the Observatory at Armagh, Northern Ireland. The dial shows hours (24 anti-clockwise) at the bottom, seconds at the top, and minutes on the main dial. The case is sealed to reduce temperature and barometric errors in timekeeping. The wood is mahogany.

OPPOSITE

Plate 42 Two fine reproduction marquetry longcase clocks made in 1975 for clockmaker M. V. Tooley of The Lee, Buckinghamshire. When marquetry is cut, each sheet of veneer provides male and female parts so that two cases can be made from them. The cases are identical except for the reversal of woods or colours of the patterns and surrounds.

There is more about them in Chapter Eight. After about 1750, London makers concentrated only on special longcase clocks and so some of the finest examples mechanically are of this period.

The roots of clockmaking in several parts of the country go back into the seventeenth century and longcase clocks were being made outside London before 1700. It was not until about mid-century that most of these industries got into their full stride, led by the clockmakers of Yorkshire, who exceeded all others in the numbers of longcase clocks they produced, many of excellent quality, followed closely by Lancashire. There were makers in every county of England; many in Scotland, particularly the south; scattered ones in Wales; and a good sprinkling in Ireland, particularly in the north.

An unusual style developed in the north of England was a brickwork pattern to the edges of the base of the case. By about 1790 some cases had lost their fine proportions, particularly in the style called a 'Yorkshire case', where the makers strained after novelty (see Plates 28 and 40). The case became about half as wide again as an orthodox one, with a small door, and was overshadowed by a large hood over a painted dial. Many local makers continued to produce cases of attractive proportions, however, even during the painted dial period.

There was a brief vogue from about 1875 among important Victorian persons for exceptionally tall – about nine feet six inches – and ornate clocks in carved mahogany with glass fronts and tubular chimes.

The tradition of good design continued only in regulators, which were made as time standards for use by the clockmakers themselves and public services. The cases were therefore usually quite plain, but constructed with the same care and precision as the movement (see Plates 41, and 89–91). They were common until the clockmaker could obtain a time signal by the radio in the 1920s. Even today an occasional (and exceptional) clock repairer will make himself a fine regulator. A few present day clockmakers produced excellent reproductions of old longcase clocks as shown in Plate 42.

Woods other than those mentioned were occasionally used for cases. One was maple, in two forms – birds eye with small circular patterns over it, and straight-grained. A veneered case of straight-grained maple is shown in Plate 69.





CHAPTER SIX

DIALS
AND
HANDS

OPPOSITE *Plate 43 a–d* The main changes in the brass dial over about a century are shown by these four pictures. ABOVE LEFT *a*. At first the chapter ring was very narrow and the hour hand had a long stem. The dial was small and the corner spandrels simple with the maker's name engraved along the bottom edge. OPPOSITE ABOVE RIGHT *b*. Then the hour hand became more elaborate and the chapter ring wider. The minute numerals moved outside the ring. OPPOSITE BELOW LEFT *c*. Next the maker's name moved into the central zone and the minute numerals became bigger, as did the seconds numerals. The spandrels are much more elaborate. OPPOSITE BELOW RIGHT *d*. On most clocks with brass dials made after about 1750, the quarter-hour divisions on the inner edge of the chapter ring, as well as the half-hour ornaments, were omitted.

So often is an antique clock regarded merely as a piece of furniture that its function – to tell the time – is forgotten. Truly the most important visible parts are the dial and hands. The case, although converting it to a valuable and beautiful article, is primarily to support and protect the movement with its heavy weights and long pendulum and to keep out dust.

Dials reflected the technical improvements in clocks and also the increasing need of the owners, as the pace of living advanced, for stricter timekeeping. When the country was mainly agricultural, men regulated their lives by the sun, by the hours of daylight. For the needs of animals and the land, an hour either way made little difference. But industry was growing rapidly. England was fast becoming the factory of the world and without good timekeeping it was impossible for a factory – let alone an entire industrial society – to function.

The emphasis in many books about old clocks is on their artistic values, the inference being that they were only playthings. This is not true. Because inventors had no use to society as a whole, they were supported by rich, individual patrons and their inventions were given an 'artistic' treatment to please the patron and encourage him to believe he was supporting something worthwhile. It is only in very recent times that the inventor has been employed as such and is permitted to present his models in string and sealing wax, because the only need is for them to work. Even so, when such articles reach the public, they are still commonly 'dolloed-up'.

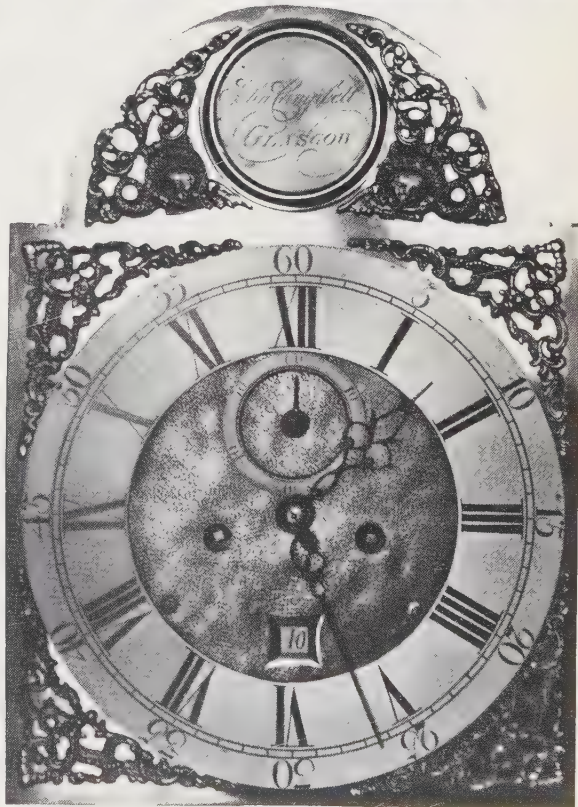
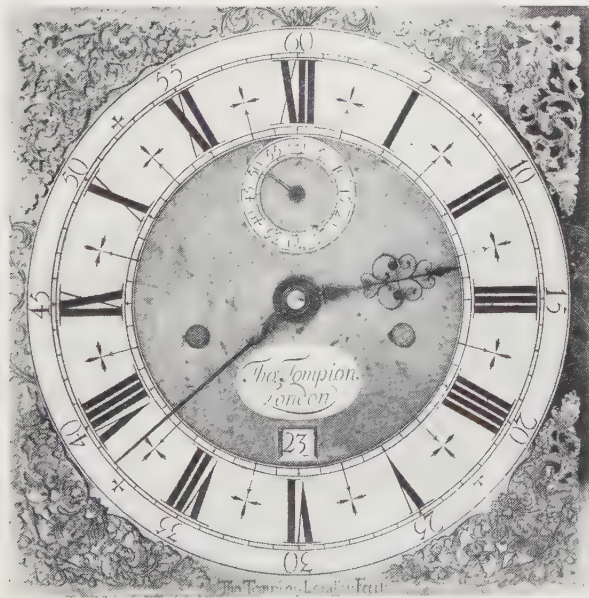

From very early times, therefore, mechanisms have had decoration applied to them. The tradition lasted right through the Industrial Revolution, when, for example, a factory loom would have ornate legs like a dining-table. With clocks, then, their past usefulness must not be obliterated by over-emphasis of their artistic heritage.

Before the long case, clocks in general use had only a single hand indicating the hour. The dial was divided normally into twelve hours indicated by Roman numerals. The pendulum brought improved accuracy and general use of another hand indicating minutes, makers of longcase clocks almost universally adopting two hands from the first. An exception was a simple one-hand longcase clock that country craftsmen continued to make without developing its design, throughout the eighteenth century.

Roman numerals for the hours are almost invariable on longcase clocks and the 'weight' of the VIII is usually balanced by IIII instead of IV on the corresponding place on the other side of the dial. The tradition has continued to today, although there are some exceptions, one being the 'Big Ben' dials. During the last war many members of the forces sold watches with IV instead of IIII to King Farouk, who collected them.

There is a story that the tradition began when Henri de Vick, one of the first French clockmakers, constructed a public timekeeper for his king, who declared that the IV was wrong and should be IIII. Upon de Vick's insistence that *he* was right, he was promptly reminded that the king was never wrong and directed to do as he was told. Very occasionally one comes across painted dials on clocks made between about 1810 and 1830, and later engine-turned brass dials that have Arabic numerals, but they are not so well balanced as the Roman dials (see Plate 59).

Half-way between hour numerals a simple decoration – such as a diamond, star, or fleur-de-lys, indicated half hours (see Fig. 13).

Quarter hours were marked by four divisions between the chapters, as the hour numerals are called, on an inner circle. Minutes were marked by five divisions between the chapters on an outer ring (see Fig. 14).

A clock that was made with one hand has only the engraved ring showing quarters – that inside the chapters – and not the ring showing minutes (see Fig. 13 and Plates 3, 71, and 75). Sometimes



a minutes hand was added later to such clocks. The absence of an engraved minute ring immediately indicates the fact (see Plate 29). Also, a dial with minute markings which has an hour hand only, has been faked to appear to be a one-handed clock or has the wrong chapter ring. The development of the chapter ring is shown in Plates 43 *a-d*.

The chapter ring is the ring of brass up to about two and a half inches wide on which the hours and other divisions are engraved, the incisions being filled with black wax and the brass silvered. The chapter ring is fixed on the front of a brass plate – the dial plate – which comprises the background of the dial. Pegs in the back of it pass through the dial plate and are held in place by taper pins (see Plates 44 and 45). The dial plate was usually left with its brassy colour and various decorations applied. These will be described later in the chapter.

Domestic clocks almost invariably have 12-hour dials. Occasionally special ones were made with 24-hour dials for astronomers, the sequence I to XII being repeated round the chapter ring (see Plate 96). The hour hand turns once in twenty-four hours and the minute hand once in an hour as usual. Some clocks with 24-hour dials were made by Thos. Tompion and a few other makers followed suit. There are otherwise ordinary longcase clocks of mid-eighteenth century to be seen with such dials, probably made for a special purpose or merely in imitation of

ABOVE LEFT
Fig. 13 One-hand dial showing hour, half-hour, and quarter-hour division.

ABOVE RIGHT
Fig. 14 Early two-hand dial. The outer minute ring has the numbers within the ring.

Plate 44 A typical plated 8-day movement of about 1750–60 with inside count-wheel. It is in a Lancashire clock by Edward Barlow, Oldham, and has a moon dial (the top toothed disc) and a calendar ring (the internally toothed ring). The dial is brass and the clock is in an oak case.

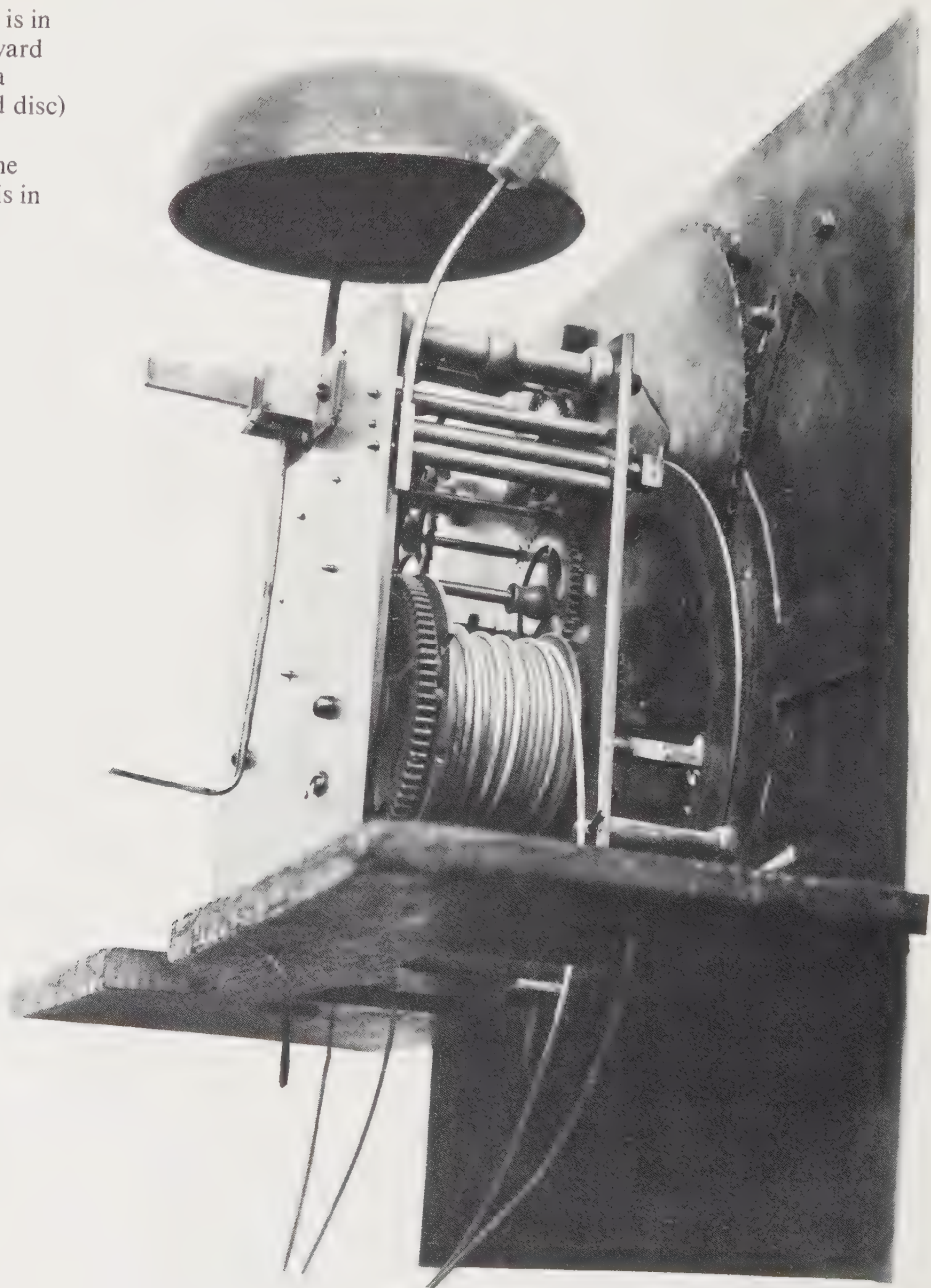

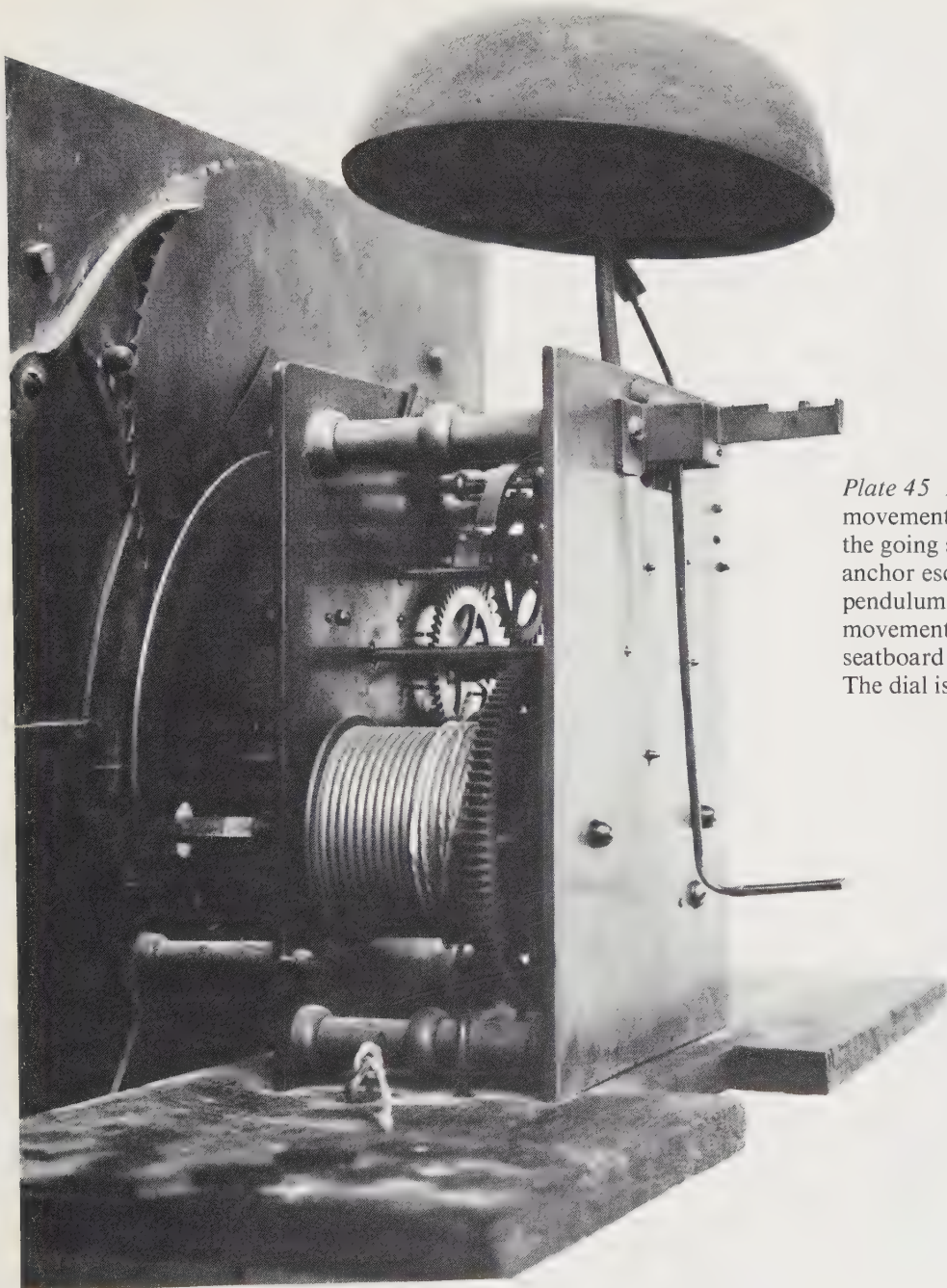

Plate 45 Another view of the movement in Plate 44. From the going side, showing the anchor escapement, crutch, and pendulum cock. Note how the movement is anchored to the seatboard by a hooked bolt. The dial is shown in Plate 68.



scientific clocks, as what would be called today 'status symbols'. The 'double XI' dial was also on some month clocks because it reduced the fall of the weight.

At first dials were small and square – about eight inches square – to suit the case height of just over six feet and its narrow width. When the case height increased after about 1675 with the introduction of the long pendulum, dials grew to about ten inches square in proportion. About the turn of the century, cases grew still taller and dials increased to eleven and twelve inches square, the 12-inch form becoming the general style. Towards the end of the eighteenth century some clocks were made with 14-inch and even larger dials.

In general there are two shapes of dial, the square and the break arch. The break arch has a semi-circular top (see Plate 55). The square is the earlier, but continued to be made until the end of the period. The break-arch dial came into fashion ten or twenty years after the eighteenth century began. This, too, continued in favour until the long case finally disappeared, and after say 1725, became more common than the square dial for better quality clocks (see Plate 47).

The break-arch shape for a dial was introduced by Thos. Tompion a score of years before it was adopted by other makers. He employed it to indicate the equation of time (see Plate 17). The extra space was sometimes used for a silvered boss bearing the maker's name or a motto (see Plates 58 and 83), or for a finger indication operating a mechanism for silencing the striking mechanism (see Plate 23). When moon and tidal dials became popular sometime before the middle of the eighteenth century, the break arch was a favourite position for them (see Plate 32), also for various animated models.

When the break arch became fashionable, some square dials were modified by riveting an arch to the top. A new case hood or, almost invariably a new case, had to be made. The first arches were low and the later ones almost semicircular, the style that persisted.

From the beginning, almost all longcase clock dials were made of brass and had separate chapter rings. A one-piece dial was sometimes used by good makers. Later on, it also enjoyed some favour among provincial makers and was current from about the beginning of the last quarter of the eighteenth century. It is a sheet

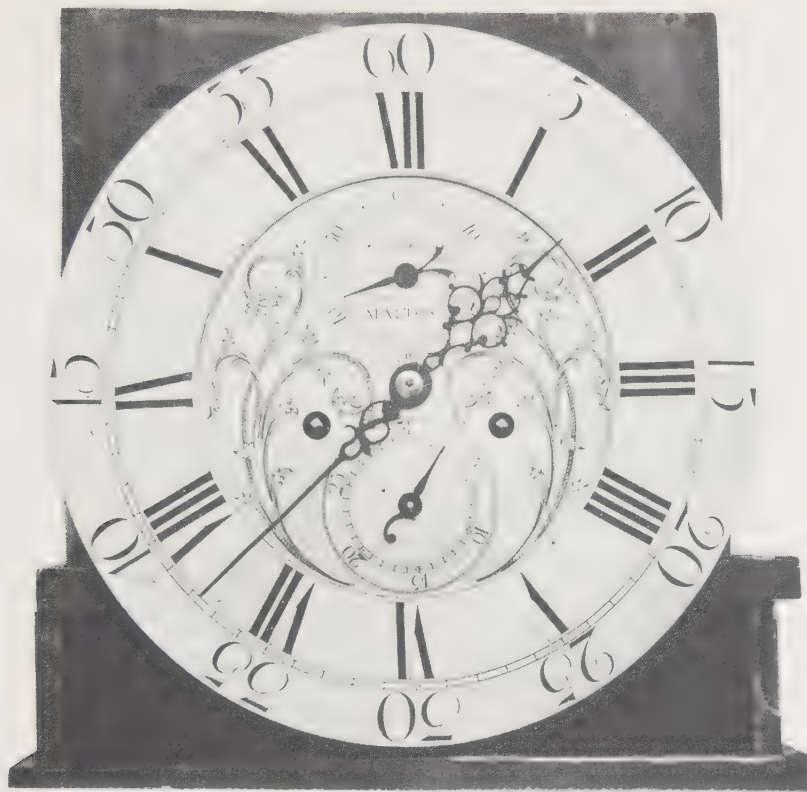

OPPOSITE

Plate 46 A break-arch dial and hood enclosing a moon and tidal clock in a clock by Thomas Walker of Newcastle, c. 1770. The extra hand on the main dial shows the day of the month, and the case is mahogany.

LEFT

Plate 47 An over-all silvered round dial on a clock by Agar of Molton, Yorkshire, shown also in *Plate 49*.

of brass, usually of break-arch shape, engraved with the chapter ring and numerals, which were filled in the orthodox way with black wax. The dial is silvered all over and a straight 'grain' can be seen down the surface (see *Plates 48 and 58*).

About 1770 another one-piece dial appeared, made of iron. This had no separate chapter ring; it also had no engraving. All the indications were painted in black on a white ground and there was usually some decoration in colour. The painted dial was introduced to satisfy the large market for lower-priced longcase clocks and is described in more detail later in this chapter.

Quarter hours are most clearly shown by the minute hand on a two-handed clock, but the forty-eight divisions engraved between

a pair of concentric circles inside the ring of hour numerals – a relic of the one-hand clock – continued to appear on dials with two hands until about 1750.

Since it was not easy to count the minutes to which the minute hand pointed, in days when minutes were unfamiliar, every fifth minute was numbered, 5, 10, 15, and so on up to 60. The numbers were at first engraved small, within the divisions themselves, between the concentric circles (see Fig. 14 and Plate 105).

On some of these early dials, every minute from 1 to 60 was numbered – a very crowded arrangement – but such dials are rare (see Plate 107).

Coinciding with the larger 10-inch dial, the five-minute numerals were moved outside the engraved ring of divisions, which required the chapter ring itself to be made wider (see Fig. 15 and Plate 53). The numerals are always Arabic. At first they were fairly small, then towards mid-century, they grew larger and larger until they were nearly as big as the hour chapters themselves (see Plate 47).

Earlier than about 1725, there was a simple decoration between each five-minute figure (like the half-hour decorations between the hours).

The quarter-hour divisions on a ring inside the chapters persisted on some dials until around 1750, although a number of makers had dropped them nearly a quarter of a century earlier. Their omission became the general rule not long after mid-

Fig. 15 Later minute ring with numbers outside the minute ring. At first these had the inner quarter divisions also, as in Fig. 14; then these quarter-hour circles were omitted.



FAR LEFT

Plate 48 Mahogany cased clock of about 1770 by Hedge of Colchester. It has an all-over silvered one-piece dial that is twelve inches wide. Such dials co-existed with painted dials.

LEFT

Plate 49 Occasionally a round dial is seen on a later grandfather clock. This 8-day version by Agar of Malton, Yorkshire, is dated about 1770. The dial is silvered and delicately engraved in the zone. *See also* Plate 47.

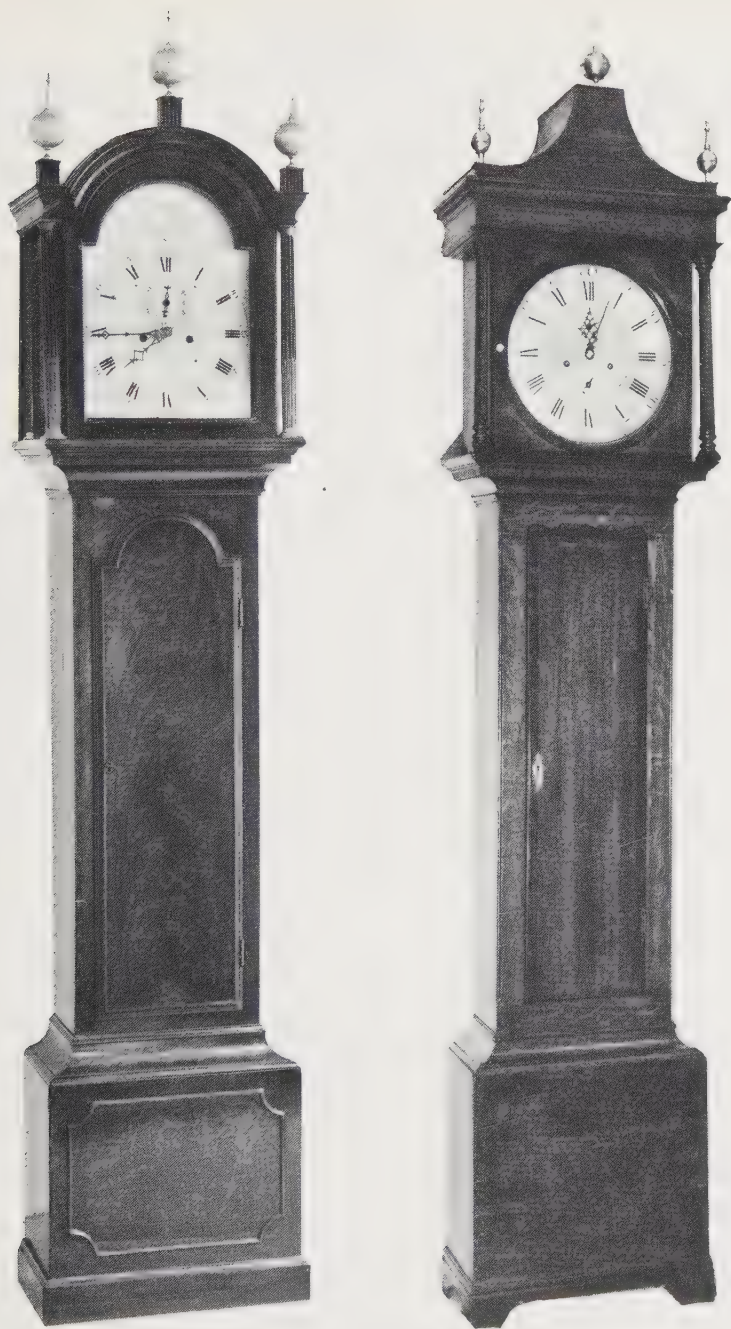
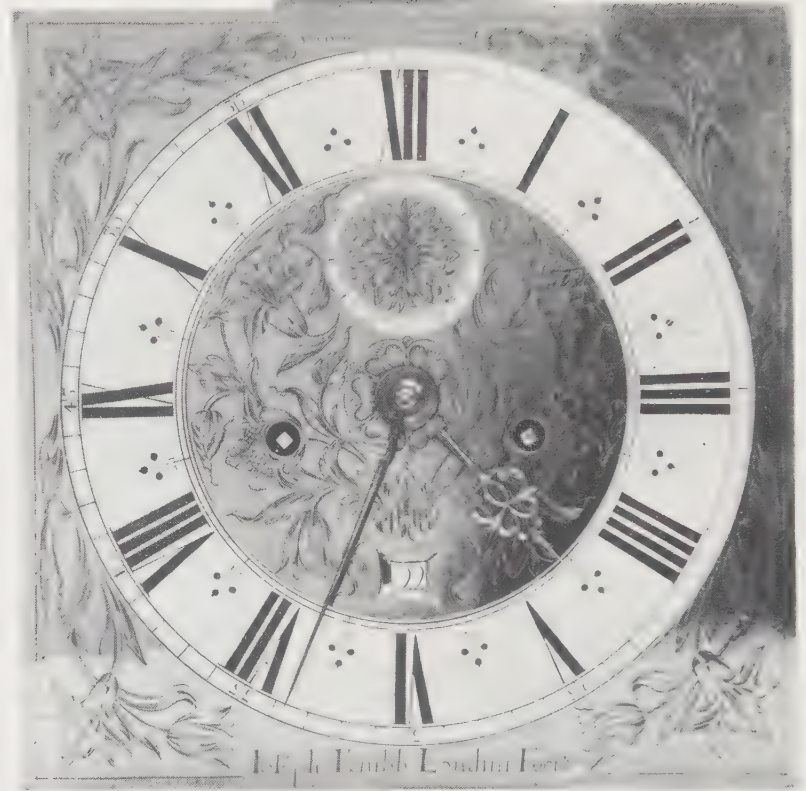

Plate 50 Very early dial of an 8-day clock without spandrels, but with engraved corners and zone. The style soon disappeared for 8-day clocks, but continued for 30-hour clocks for some time. Joseph Knibb, London, made this clock.



century (see Plate 49). A few clockmakers persisted almost to the last quarter of the century, with the half-hour decorations between the hours (see Plate 83). Simple Roman hour numerals and a minute divisions ring with Arabic numerals outside every five-minute mark were generally preferred, however.

Occasionally a clock is seen with a wavy minute circle, like a series of twelve break-arch shapes in a circle (see Plate 122). This shows Dutch influence. Towards the end of the eighteenth century, minute divisions were occasionally a series of dots on the chapter ring, the fashion common today on wrist watches. Dots were common later on painted dials.

The anchor escapement was responsible also for the introduction of a seconds dial, a small dial above the hands and inside the

FAR LEFT

Plate 51 A clock with a silvered one-piece dial that is circular. It was made about 1776 by Hedge of Colchester. Set in the trunk are a barometer and thermometer.

LEFT

Plate 52 A longcase clock in traditional style, except for the dial. It is 7 feet 1 inch high and was made about 1790 by Matthew and Thomas Dutton of London. There is a circular dial instead of a ring, which is silvered all over, with traditional spandrels. In the arch is a calendar.





Fig. 16 Three examples of spandrel – an early one of about 1675 on the *far right*, a winged cherub's head; *above* two cherubs supporting a crown in the centre, *c.* 1710; and (*below*) a later type of floral design of about 1760.



chapter ring, so positioned because the seconds hand was attached to the arbor of the escape-wheel, which is near the top of the clock (see Plate 53). Seconds hands are very common on longcase clocks.

The style of seconds rings followed chapter rings in being narrow at first then becoming wider. Numerals were Arabic and every fifth was numbered – 5, 10, 15, etc. Later on it became customary to number only 10, 20, 30, 40, 50, and 60 (see Plate 60). Some late clocks have only the quarters of the seconds dial numbered.

A silvered chapter ring fixed to a square dial leaves a circular centre and four corners of almost triangular shape. In the very earliest clocks with such dials, the five spaces were filled by decorative engraving (see Plates 50 and 77). Almost from the first, however, another form of decorating for the centre circle was matting (see Plate 105). This is a rough matt finish to the brass produced by using a punch over the surface. The laborious punching was later speeded up by rolling a spiked steel roller over the sheet of brass. The matted dial centre became a favourite of London makers and continued in favour by makers all over the country until the end. It was not the only form. Plain clear lacquered brass (Plate 68), silvered brass, engraved and silvered brass (Plate 47), and elaborately pierced centres also enjoyed some popularity. Occasionally the chapters were engraved on a circular disc instead of a ring, which was silvered, as in Plates 51 and 52. Elaborately engraved areas around the centre of the dial had a revival later in the north of England (Plate 74). Very occasionally the centre of a brass dial was *painted* with scenes, flowers, birds, etc. (see Plate 32).

From a few years before 1700 to about 1710, the winding holes in the centre of some dials had two or three concave rings formed round them. This decoration was applied particularly to matted dials and was probably intended to avoid marking of the matted surface while inserting the winding key (see Plate 53). Ringed holes are seen on a few later clocks, too.

The small square aperture in which the day of the month is shown through a dial centre sometimes had a little decorative scroll engraving. The calendar hole itself was sometimes made circular after about 1750. Clocks with painted iron dials usually

had a semicircular slot through which several painted numerals could be seen, the current one being indicated by a central pointer.

Engraving was also used for a herringbone pattern around the edges of some early square and break-arch dials.

The very first engraved corner decorations of dials gave way almost at once to cast metal decorations known as 'spandrels', which are of Dutch origin and continued in use throughout the use of brass dials, although engraved corners had a small revival in the second half of the eighteenth century.

Spandrels are a good guide to age, as they went through a fairly definite sequence of design. As a spandrel is fixed by a single screw through the back of the dial, it is easily replaced, so that it is wise with valuable clocks to see, if possible, that some 'doctoring' has not been carried out.

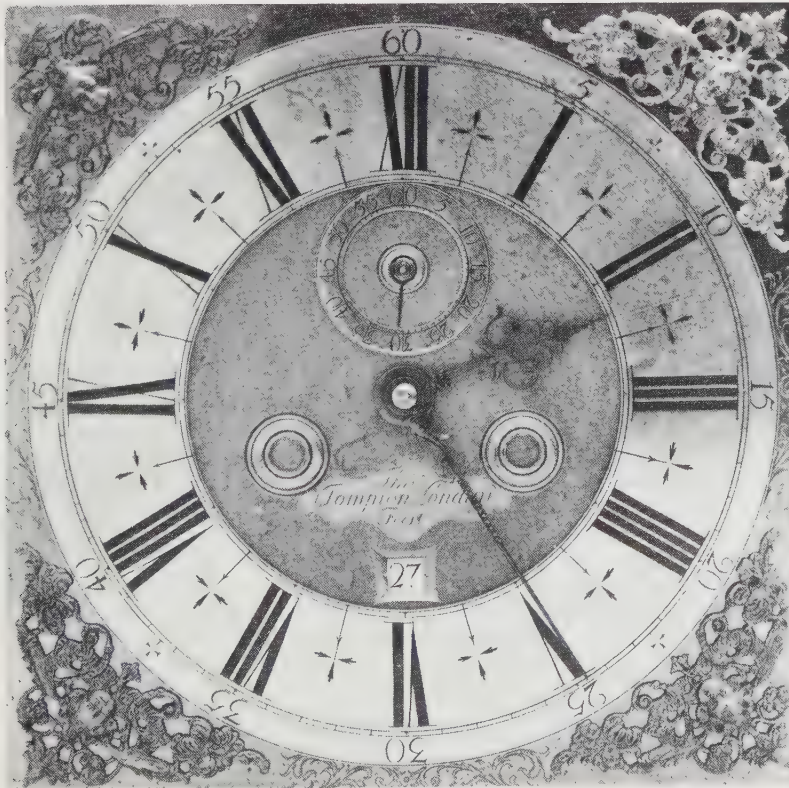

LEFT

Plate 53 Dial of a clock of around 1700 by Tompion with the name in the zone, later and more elaborate spandrels, and ringed winding holes. The squares are covered until maintaining power is operated.



Some spandrel designs are shown in Fig. 16. The earliest was the face of a cherub with wings each side designed to fit but not fill the triangular space. The cherub's head was in high relief from the beginning, say 1660, for about thirty years (see Plate 107). Then the relief became lower and the spandrel was engraved by adding foliage around the face (see Plate 53). The new style of cherub lasted from say 1690 to around 1715. Both types were chased to smooth the castings and then fire gilded.

Another pattern that appeared within the second period showed two complete cherub figures holding a crown (see Plates 12, 54, and 71). An American version is shown in Plate 128. The crown was at the apex of the triangular space and the cherubs' feet towards each corner, the remaining space being filled with foliage.

After the first decade of the eighteenth century and for about fifty years, a spandrel with a woman's head framed by acanthus foliage was popular with many makers (see Plate 55). This was in low relief and not well finished, unlike earlier spandrels. Sometimes a flower was used as an alternative to a face.

This design was accompanied and followed by others with foliage and scroll work but no head (see Plate 52), a style popular from about 1760 onwards on most brass dials. Not infrequently there were revivals of old styles that when considered without other features of the clock can be misleading. Some makers outside London used, as spandrels, four cast female figures representing the seasons.

At an early stage, specialists in brass castings offered designs to clockmakers, so similar spandrels are found on different makers' clocks. Also, a maker would apparently take a fancy to a particular design and use it regularly on clocks he made, at least until he became tired of it.

Spandrels are cast in brass from an original pattern, cleaned up by filing and other tooling, and finished by polishing and gilding. In general, the earlier they are, the simpler in design and the better finished. Later in the eighteenth century the casting was only given a perfunctory going over by hand before being gilded. The best guide to the date of a clock by the spandrels is to examine the quality and finish of the casting. Both deteriorated considerably over the years.

Decoration in the arch of break-arch dials was mentioned

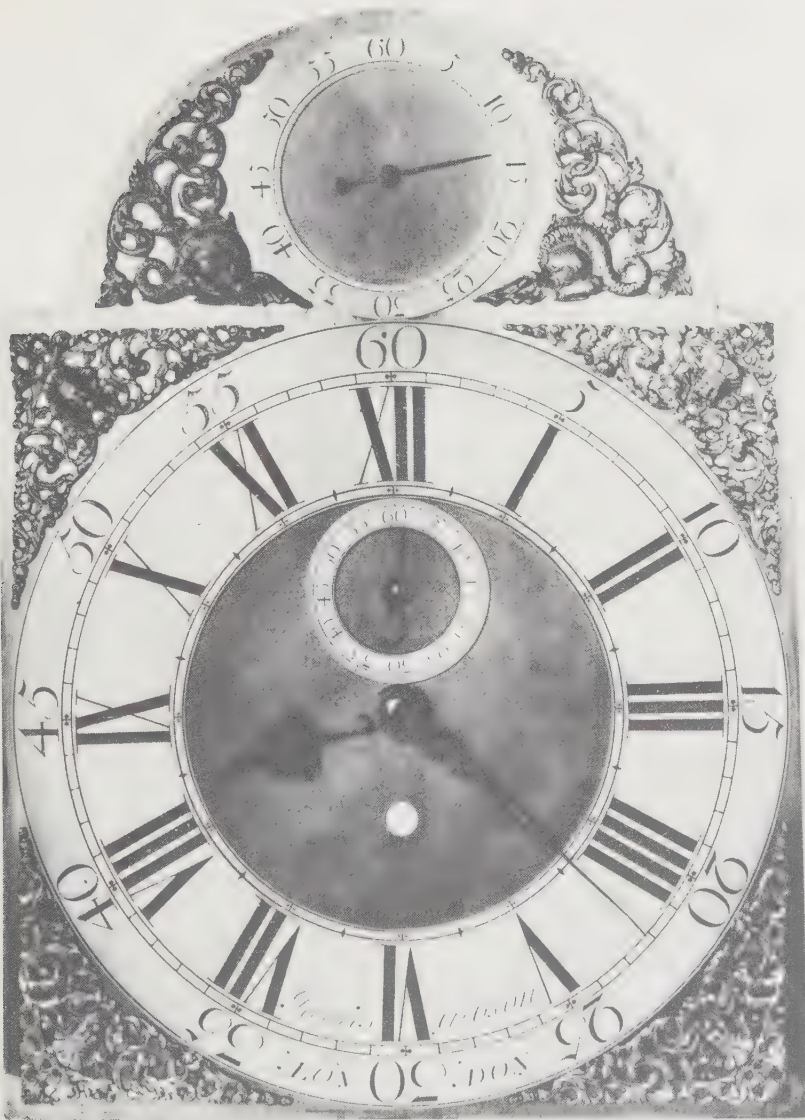

OPPOSITE

Plate 54 Intricate, fine marquetry is the feature of this case, with a domed hood of Joseph Windmills, London, clock. It is 7 feet 10 inches high and is dated about 1705. The moulding under the hood is now concave.

LEFT

Plate 55 Break-arch dial of a timepiece by James Gibson of London, showing large minute numerals. There are quarter-hour divisions, but no ornaments showing half hours. It does not strike. Note the single winding hole. The dial in the arch is for pendulum regulation.

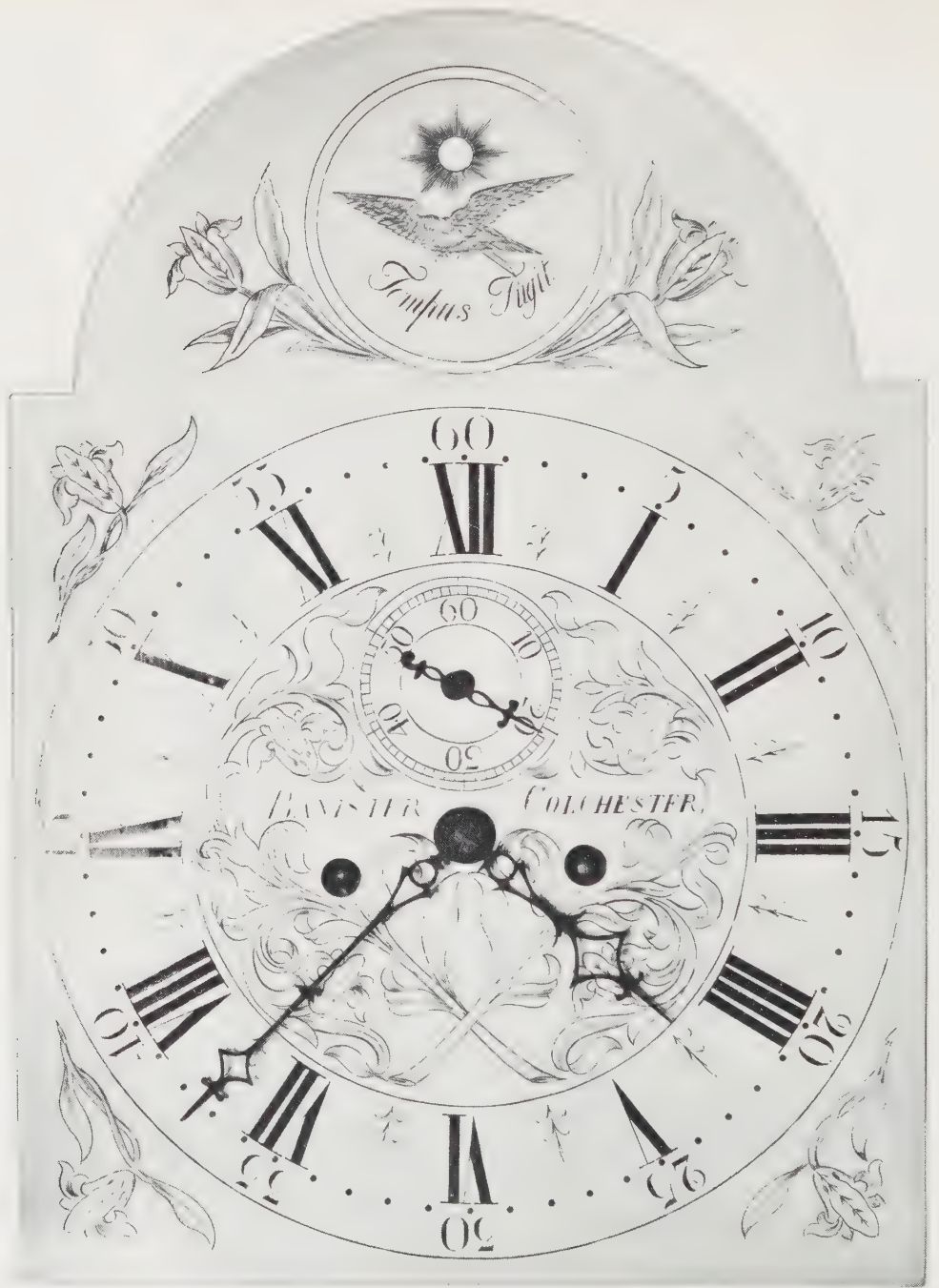

earlier; spandrels were employed at times for space filling here, each side of, say, a circular day of the month or strike-silent dial, or round a circular name boss.

An important 'decoration' of the dial which affects the present value of a clock is the maker's name. Until 1675 or later it was commonly engraved in a straight line along the bottom edge of the dial plate below the chapter ring, where it could only be seen by raising the hood, or opening the door. For some years makers liked to latinize their names and add their town and the word 'fecit' to record themselves as makers. Examples are: Johannes Fromanteel, Londini, fecit; and Gulielmus Clement, Londini. The English name with 'fecit' was common also. Here are two ways in which John Knibb signed his name: Johannes Knibb, Oxoniae, fecit, and John Knibb, Oxon, fecit (see Plates 50, 105, and 107).

In the last ten years or so before the eighteenth century, makers began to display their names more prominently by having them engraved on the chapter ring itself, each side of the numeral VI, on a nameplate below the dial centre over the matted area (see Plate 53), or engraved on a scroll. A circular boss in the arch was used for the name at times with break-arch dials and if a semicircular dial giving moon, tidal or equation of time information was incorporated, the maker's name might be combined with this.

When engraved dial centres returned to favour in the latter part of the eighteenth century, particularly in provincial centres of clockmaking, the engraved name and location of the maker was usually a part of a pattern of acanthus leaves or other foliage, flowers, butterflies, and so on (see Plate 56).

The painted iron dial, which was introduced about 1770 was at first about eleven to twelve inches square and mostly white except for corner decorations painted on instead of spandrels. Probably most had break-arch tops, but still with simple decoration. Numerals and dial markings were in black and the coloured decorations were usually flowers, fruit, or birds. Some makers of early white dials preferred 'spandrels' painted in gold (see Plate 57). Geometrical designs of shells, fans, and so on were popular from a few years before 1800 to about 1820 and were followed by country scenes. For a period of about forty years from about 1780 to 1820 there was also a vogue for no decoration at all

OPPOSITE

Plate 56 The all-over silvered break-arch dial with engraving of a clock by Joseph Banister, Colchester, made about 1825. The carved oak case is shown in Plate 37.



ABOVE

Plate 57 Painted dials came in about 1770 and quickly ousted brass dials for all but special clocks. William Elliott of Whitby, Yorkshire, made the clock with the white dial above. It is an early example, with spandrels imitated in gold paint. The moon dial also shows the moon's age. Note the wavy minute hand. The case is shown in Plate 98.



Plate 58 Enamelled dials are very rare. Thomas Clare of Warrington, Lancashire, used a Battersea enamelled dial on this clock with an 8-day movement of about 1770–80.

in the corners. The dial became bigger, up to about fifteen inches across after 1800, and more and more decoration was applied until, before the first quarter of the nineteenth century was out, decoration in the arch had joined the corner decorations to form an all-over pattern only omitting the dial area itself. The four seasons were sometimes represented scenically in the corners and common themes for the arch were birds and flowers from the beginning until nearly 1800, and the maker's name alone for about ten years from the beginning of the white dial. A picture or decoration in an oval or other shaped frame (see Plate 59) was popular before the century turned and remained so for about twenty years, by which time most makers were turning to unframed scenes such as sailing ships at sea, country views with people, castles or ruins, hunting scenes, religious settings, or the still favourite flowers and birds (see Plates 60–62). Decorations also appeared from time to time inside the circle of the dial, usually under the XII chapter, but elsewhere as well (see Plate 136).

Moon dials were an occasional feature in the arch of a painted dial whether of an 8-day or 30-hour clock right from the beginning, but they became rarer after the first quarter of the nineteenth century. A hand for turning the striking mechanism on or off was also a feature of some arches from the beginning of the period to a few years after 1800, and occasionally it was occupied by an animated scene as described in the next chapter.

Professional dial writers (painters) supplied finished dials to clockmakers and one comes across clocks with almost identical scenes on their dials but different makers' names. It seemed universal, however, for the black parts – circles, divisions, hour and minute numerals, signature, etc. – to be painted in water colour containing lamp black, but the scenes were painted in oil and sometimes carefully baked to harden them. This accounts for the fact that many dials today have most of their black parts missing although the coloured areas may be in good condition. Over the years, wiping the dial with a damp cloth has removed much of the black (see Plate 63).

A few makers introduced circular dials for a few clocks (see Plates 47 and 51). Some were silvered brass and some painted iron. A very occasional one-piece dial turns out to be true vitreous enamel on copper or brass, but it is very rare (see Plate 58).



ABOVE

Plate 59 Coloured paintings in the corners soon eliminated painted imitation spandrels, and country topics became common in the arch. This dial is dated between 1800 and 1810. The clock, by R. Morland of Kirby Malzeard, Yorkshire, is shown in *Plate 80*. Note the Arabic numerals.

LEFT

Plate 60 In the later painted white dial period from about 1830 onwards, dials became more and more decorated. This version is from an 8-day clock by Paul Gunter of Huddersfield, Yorkshire, made after 1837.



Another rarity is a painted convex dial, perhaps with a flat arch. Convex dials were common on table clocks of the earlier nineteenth century.

Most of the earlier white dials, up to the turn of the century seem to have the minutes indicated by dots (see *Plate 59*). After

RIGHT

Plate 61 Another painted dial, with a typical religious scene in the arch. The clock has matching hands, like others with white dials. It is by John Kettlewell of Ripon, Yorkshire, and was made about 1840. The lower hand indicates the date.

OPPOSITE

Plate 62 Hunting scenes are represented on the dial of a Richard Snow clock. He worked at Pateley Bridge in Yorkshire, and made the clock about 1840. It has a false plate, like most clocks with white dials from specialist dial suppliers, but the dialmaker's name, J. Jukes, is stamped on the dial and not on the false plate, as was more usual.



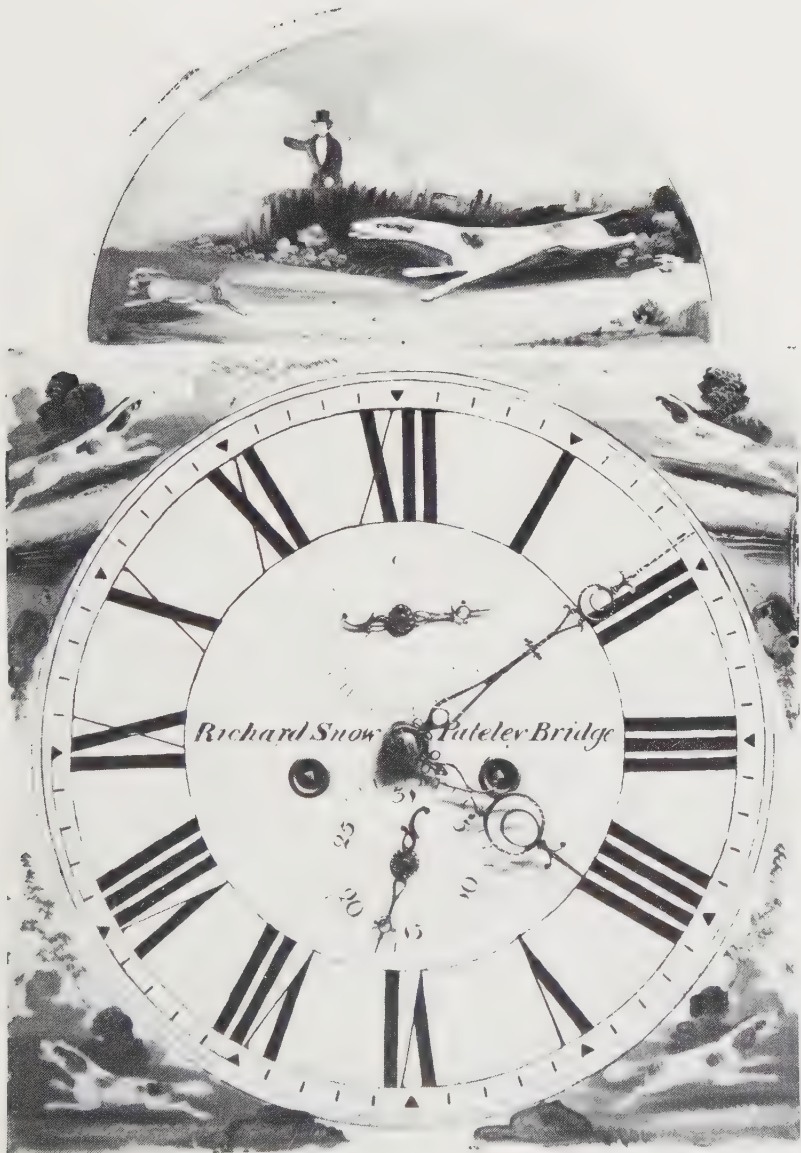



ABOVE LEFT

Fig. 17 Early style of hands from a clock dated about 1700. Even earlier styles had simpler hour hands as in Plate 1.

ABOVE RIGHT

Fig. 18 The cross-over pattern for hands in several variations after about 1720.

BELOW

Fig. 19 One of the most popular designs of hour hand after about 1750.



1800 line divisions gradually became universal. Minutes were indicated in Arabic numerals like those on brass dials until about 1820 when it became more common and then universal for the numbering of minutes to be omitted. There was a short vogue for about twenty years after 1800 of Arabic numerals for the hour chapters.

The earliest known suppliers of painted iron dials to the trade were Osborne and Wilson of Birmingham who were advertising their products as something new, 'in imitation of enamel', in 1772. They were followed by many more suppliers, particularly in Birmingham, who exported to North America as well as supplying clockmakers in the UK. The idea of the white dial was so successful that it had more or less eliminated the brass dial by the last quarter of the eighteenth century. It continued in vogue for another eighty years or so, having a run of about ninety years compared with, say, a hundred and ten or twenty years for the brass dial.

Leaving until the next chapter indications other than time of day, we now consider the hands. The minute hand was unknown in domestic clocks until the pendulum made it a practical proposition; similarly it was not worth incorporating a seconds hand until the seconds pendulum was invented. The longcase clock, then, directed considerable attention to hands. Its predecessor, the lantern clock, made do with an hour hand only, which was of simple arrow shape at first and was pierced in an elementary loop pattern on late examples.

Early longcase clocks also had simple hour hands. These hands look longer than they are because they extend to the inside edge of the narrow chapter ring and their simple pierced spade decoration is near the tip of the hand, so that the point is short.

The first minute hands are to be seen with this type of hour hand. At the beginning the minute hand was fairly plain, having a short S-shape near the boss, from which a long thin point projected (see Plates 77 and 105).

In the last quarter of the seventeenth century, as the chapter ring became wider, so the hour hand became shorter and much more ornate with additional loops and ears appearing in the piercing. Fig. 17 shows a type being used just before the eighteenth century. They became even more elaborate as the century turned, and perhaps the most common pattern until the last quarter of the eighteenth century was known as the cross-over

loop (see Fig. 18). A third popular design was basically that in Fig. 19, which came in around 1750.

Minute hands did not change much throughout the entire period, although ears on the S-shape near the boss were varied and sometimes extended to make loops of various elaboration, this becoming most pronounced around mid-eighteenth century. The wavy or serpentine minute hand with ears on each curve and an arrow head end appeared and became popular in the second half of the eighteenth century (see Fig. 20 and Plate 57) on some clocks. The only exceptions were the minute hands of clocks with matching hands at the end of the century, described in a later paragraph.

Hands were made of steel by cutting and piercing, filing V-cuts in corners, and rounding edges. After polishing, the hand was given a dark-blue colour by removing any grease and placing it on a bed of sand which was heated until the colour changed. This, of course, was handcraft work and soon became a specialist trade. A clockmaker would order hands of a particular design from a hand-maker, and often retain that particular pattern. Some localities even had their own designs.

Until the first quarter of the eighteenth century had expired, makers were careful to provide hands correctly proportioned to the dial, the tip of the hour hand just reaching the inner circle showing the quarters and the minute hand tip nicely scaling the minutes, but with larger outputs of clocks, and of hands by the specialist makers, less attention was paid to this detail.

Nearly all hands were of blued steel to contrast with the matted brass-dial centre. But gilded and often hammered brass ones were employed with the very occasional velvet dial on early clocks. (Brass is hammered to make it tougher.) When the white painted dial was introduced in about 1770, steel hands similar to those for brass dials were used with it, but around 1790, perhaps with the advent of the all-over silvered dial, another fashion in hands appeared – hands that matched. Up to this time the hour and minute hands were of quite different designs, although they matched in general proportions, a heavy-looking hour hand being used with a heavy-looking minute one, for example. Matching hands, on the contrary, were very similar in all respects except that the minute hand was elongated (see Fig. 21). Matching hands were at first made in blued or blackened steel. In the first decade

Fig. 20 The wavy style of minute hand, a Dutch fashion, popular after about 1750.



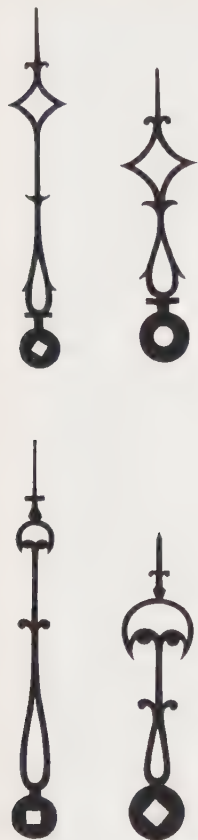

ABOVE
Fig. 21 Two examples of matching hands.

OPPOSITE
Plate 63 Often the black figures and circles of a painted dial have been worn off by cleaning, because they are of water-based paint, whereas the coloured scenes, which are in oil-based and baked colours, remain intact, like this representation of the Last Supper.

of the 1800s, brass became the usual metal in which matching hands were made. During the rest of the longcase period it is unusual to find a clock without matching hands.

A few later clocks were made with spade hands or an hour spade hand and a minute pointer. The ends are in fact heart-shaped but supposed to be like a French spade when they were named. The two styles are shown in Plates 97 and 99.

Hour hands made for the original one-hand clocks were different from those to be accompanied by minute hands. They had longish tails, the object of which was to help set the hand, i.e. the hand and its tail could be used like a turn key (see Plates 71 and 75). This kind of hand, however, continued to be used on the atavistic 30-hour clocks referred to earlier which continued to be made by minor clockmakers throughout the eighteenth century.

The earlier single hour hands often had oval bosses, but circular bosses were universal on all hour and minute hands used together. The central hole in the hour hand which fitted on to the hour pipe of the clock movement was square on earlier hands. During the last three-quarters of the eighteenth century these holes were usually round. The hole in the minute hand remained square.

The seconds hand was introduced about 1675. At first this hand was very rudimentary, a short thin pointer with a round boss (see Plate 105). It continued like this until well into the first quarter of the eighteenth century when it was given a tail and continued thereafter with a tail of some sort or another (see Plate 62).

A long centre seconds hand was fitted to some clocks made after about 1740. This was concentric with the other hands and always had a fair sized tail to counterbalance it (see Plates 19 and 20).

Before the seconds pendulum became established, a clock was occasionally provided with a $1\frac{1}{4}$ -seconds pendulum, about sixty-one inches long. The seconds dial of one of these was divided into forty-eight divisions instead of sixty.

Hand design in most clocks degenerated rapidly when the longcase clock went out of fashion and even today a clock (or watch) is rarely seen with well-thought-out hands. Only the regulator carried on the tradition of good design, mainly because the hands had to be simple and functional.





MOON DIALS,
CALENDARS
AND
OTHER SPECIAL
INDICATIONS

OPPOSITE LEFT

Plate 64 An equation of time dial, on a clock by Francis Gregg of Covent Garden, London. The annual calendar and equation indication are on the same moving dial. Seconds are shown in the arch, with regulator and strike/silent dials on each side. Makers probably supplied sundials with their equation clocks.

OPPOSITE RIGHT

Plate 65 Another form of equation of time indication in the trunk of a very fine clock by Daniel Quare, London, c. 1695, which is 9 feet 3 inches tall. The smaller hand indicates sun fast and sun slow, and the longer one the annual date.

The owner of a longcase clock in the seventeenth century could not set his clock to time by listening to a radio time signal, or by dialling the 'Speaking Clock'. He could not even check by a public clock in reasonable certainty that it would be accurate. There was no public time service. Indeed there was no public time – no accepted time for the whole country. Local times varied across the country.

The clock owner had ultimately to rely on a sundial. Even an accurately made sundial could only be read to within a few minutes and then only when the sun shone. But there were greater complications.

Time is based on the rotation of the earth. Twenty-four hours is the interval between the sun at its highest point in the sky (its meridian) one day to its meridian on the following day. That is, one rotation of the earth. It would be ideal if the interval were always the same. Unfortunately, it is not. As the earth's orbit is not a circle, or in the equatorial plane, hours calculated from the sun are not equal. This was not appreciated except by astronomers until the accurate longcase clock came into general use.

Those who checked their clocks regularly by the sun (or by the stars – see page 138) discovered that the clock seemed to gain over sixteen minutes at some times of the year and lose about fourteen and a half minutes at others. Since all the clocks in the country gained together and lost time together, adjustment of the clocks was not at fault. The sundial was apparently to blame. More accurately, the variable speed of the earth round the sun causes the length of days to vary through the year. The hours of

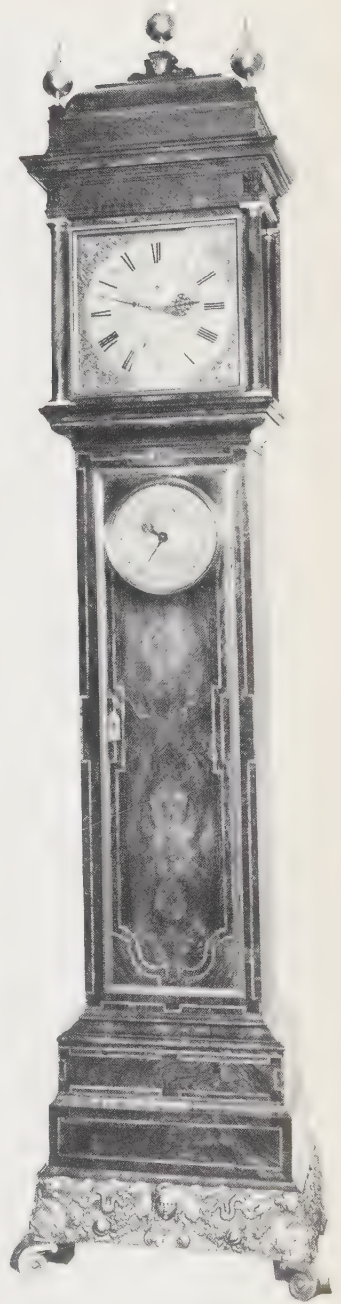
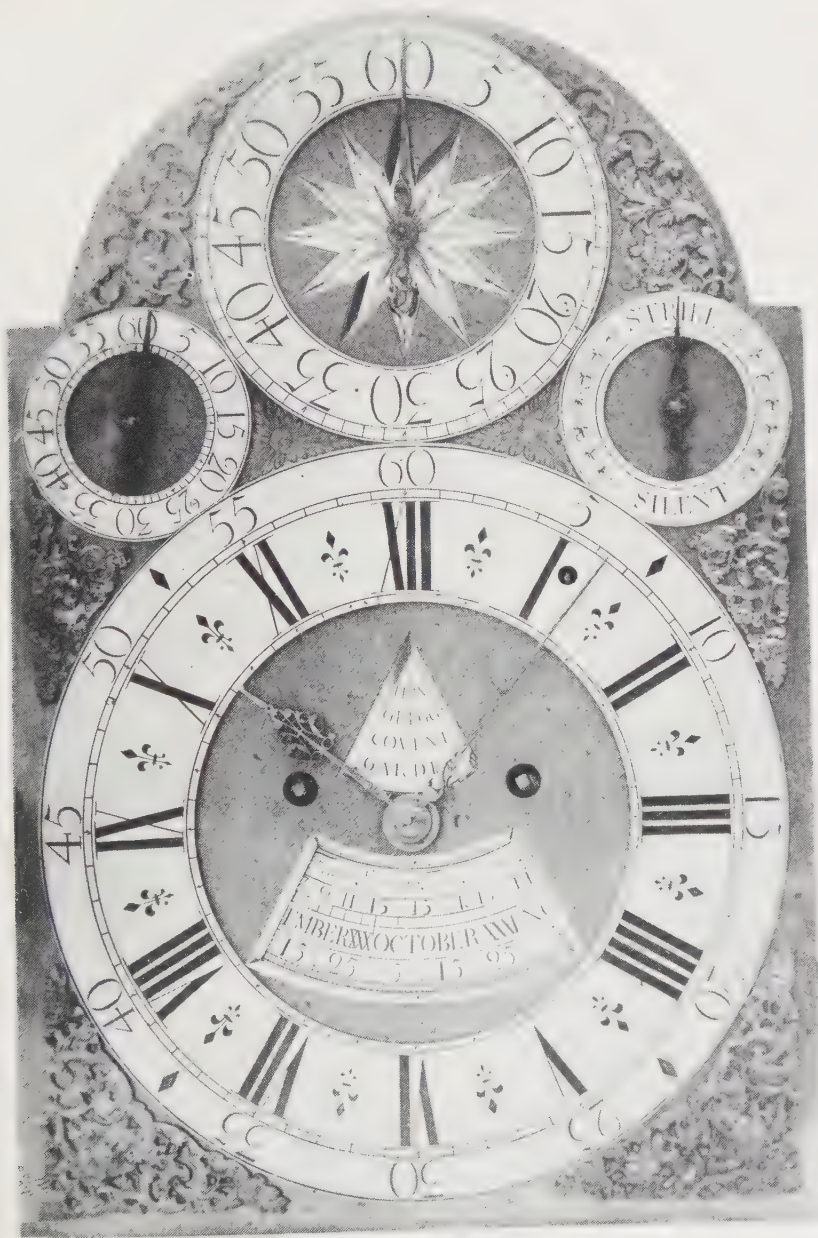

different length shown on the sundial had therefore to be corrected in order to check the time in 'equal hours' – that is 'mean time' – kept by the clock.

The difference between solar time and mean time is known as the 'equation of time'. It is a value in minutes and seconds which varies throughout the year and has to be added to or subtracted from time shown by the sundial in order to arrive at 'equal time' as shown by the clock. The word 'equation' is employed in its archaic sense of meaning 'difference'.

Someone might protest, 'Why not make clocks go like the sundial?' It is difficult, because the rate of a clock would have to be continually varied, which *was* done in Japan (although for another reason) and held up the development of accurate clocks there for over a century.

The rate of a clock, by the way, is the regularity of its timekeeping. A clock that is exactly on time at, say, every hour, has a perfect rate. A clock that is five seconds fast after the first hour, ten seconds after the second, fifteen seconds after the third and so on, also has a perfect rate. If the gain or loss is always the same, the clock's rate is still perfect, and the clock can usually be rated to give correct time of day.

When the losing or gaining rate of a clock is inconsistent, or changes from one to the other, the rate is bad. A clock with a bad rate may still show the right time at the end of a week if the total losses are equal to the gains. This does not matter if the clock is for ordinary domestic duties, but it is a serious fault in clocks and regulators for navigation or scientific purposes.

Christiaan Huygens was probably the first to calculate the equation of time in 1662. A. Fromanteel issued some calculations in England in 1666, which were followed by the 1668 tables published by John Smith, and of 1672 by John Flamsteed (see Fig. 22). The maker of high-quality clocks would supply a table of figures and perhaps a sundial with each clock.

The owner would therefore have to choose a sunny day to set his clock to time, reading the sundial at, say, twelve noon, and looking up the equation table. If the table said +10 minutes for that day of the year, he would set his clock to 12.10 p.m.

Very soon some clockmakers realized that the clock itself could indicate the equation of time. Mechanically the problem

460 *Joh. Flamsteedius de Inaequalitate*

Tabula Prosthaphereses dierum Naturalium absolutas exhibens, ad Annum 1672, quo Apogæon 7 grad. ☉ attingit confecta, cum loco Solis aequanda.

	γ		δ		ε		ζ		η			
	A ₁₁	S ₁₁	A ₁₁	S ₁₁	A ₁₁	S ₁₁	A ₁₁	S ₁₁	A ₁₁	S ₁₁		
0	7	51	03	3	56	0	59	5	37	0	06	
1	7	32	1	18	3	52	1	35	3	39	1	44
2	7	13	1	31	3	48	1	26	5	40	1	22
3	6	54	1	43	3	44	1	39	5	41	1	11
4	6	36	1	56	3	38	1	52	5	41	0	53
5	6	16	2	07	3	33	2	05	5	40	0	35
6	5	57	2	18	3	26	2	17	5	39	0	18
7	5	38	2	29	3	19	2	30	5	37	0	50
8	5	19	2	39	3	12	2	43	5	34	0	10
9	4	59	2	48	3	04	2	55	5	31	0	38
10	4	40	2	58	2	56	3	07	5	27	0	57
11	4	21	3	07	2	47	3	10	5	22	1	17
12	4	02	3	15	2	38	3	30	5	17	1	37
13	3	43	3	22	2	28	3	40	5	11	1	57
14	3	24	3	29	2	18	3	51	5	05	1	17
15	3	05	3	36	2	08	4	02	5	58	2	37
16	2	47	3	41	1	57	4	11	4	50	2	58
17	2	29	3	46	1	46	4	21	4	41	3	19
18	2	11	3	51	1	35	4	30	4	32	3	40
19	1	53	3	54	1	24	4	38	4	22	4	01
20	1	36	3	56	1	14	4	46	4	12	4	22
21	1	18	4	01	0	59	4	54	4	01	4	43
22	1	01	4	02	0	46	5	01	3	50	5	05
23	0	45	4	03	0	33	5	08	3	38	5	26
24	0	27	4	04	0	20	5	14	3	26	5	47
25	0	12	4	04	0	07	5	19	3	15	5	08
26	0	5	4	04	0	05	5	23	3	00	6	30
27	0	19	4	03	0	19	5	28	2	46	5	50
28	0	34	4	01	0	32	5	32	3	31	7	11
29	0	49	3	59	0	45	5	35	2	16	7	32
30	1	05	3	56	0	59	5	37	2	0	7	53

Fig. 21

Dierum Inaequalitate

Pars residua Tabulae precedentis.

	ϑ		ϕ		χ		ψ		ω		ξ	
	S ₁₁	A ₁₁	S ₁₁	A ₁₁	S ₁₁	A ₁₁	S ₁₁	A ₁₁	S ₁₁	A ₁₁	S ₁₁	A ₁₁
0	7	53	15	39	13	29	0	57	11	49	14	40
1	8	14	15	47	13	12	0	27	12	07	14	34
2	8	35	15	53	12	54	0	A02	12	23	14	27
3	8	55	15	59	12	36	0	32	12	38	14	20
4	9	15	16	04	11	17	1	03	11	53	14	11
5	9	35	16	08	11	58	1	32	13	07	14	03
6	9	55	16	11	11	37	2	01	13	20	13	54
7	10	14	16	14	11	15	2	30	13	32	13	44
8	10	33	16	15	10	53	2	59	13	45	13	34
9	10	52	16	16	10	31	3	28	13	56	13	23
10	11	11	16	16	10	08	3	56	14	06	13	11
11	11	28	16	16	9	44	4	25	14	14	12	59
12	11	46	16	15	9	20	4	53	14	23	12	46
13	11	05	16	14	8	56	5	20	14	31	12	33
14	11	20	16	09	8	30	5	47	14	38	12	19
15	11	37	16	06	8	04	6	14	14	44	12	05
16	11	53	16	01	7	38	6	40	14	49	11	51
17	12	08	15	56	7	11	7	06	14	53	11	36
18	12	24	15	49	6	44	7	31	14	57	11	20
19	12	38	15	41	6	17	7	56	15	00	11	04
20	12	52	15	34	5	49	8	20	15	02	11	49
21	14	06	15	25	5	21	8	44	15	03	10	32
22	14	19	15	15	4	52	9	07	15	03	10	15
23	14	30	15	05	4	23	9	30	15	03	9	58
24	14	43	14	54	3	54	9	52	15	01	9	41
25	14	53	14	41	3	25	10	14	15	01	9	23
26	15	03	14	28	2	56	10	33	14	58	9	05
27	15	13	14	15	2	26	10	54	14	55	8	47
28	15	23	14	01	1	56	11	13	14	51	8	29
29	15	31	13	46	1	27	11	31	14	46	8	10
30	15	39	13	29	0	57	11	49	14	40	7	51

was not simple. At four unequally spaced times in the year, the equation of time is zero – i.e. solar time is the same as mean time – at others it is a positive or negative figure and the variation is not regular. Huygens recorded that he had made a clock to show solar hours without equation tables. Fromanteel, not far behind, made an equation clock to the design of Nicholas Mercator (not the famous cartographer) about 1670. Mercator presented it to King Charles II who could not understand it. Someone in the court sold it to the clockmaker Knibb who sold it back to Fromanteel for £5. Fromanteel reoffered it in 1683 for £200! The dial showing how much the clock was fast or slow of sundial time apparently had to be set by hand, although Mercator explained to Huygens that he intended to use ‘many wheels’ to overcome this. However, the problem was truly solved not by many wheels but

Fig. 22 A reproduction of a printed page of the differences between sundial time and clock time (equal time) calculated by the first Astronomer Royal, John Flamsteed and published in 1672. Such equation of time tables were supplied with fine clocks to set them against sundials. The early tables were not accurate.

OPPOSITE

Plate 66 Still another form of equation of time dial with an indicating hand in the arch of a famous large longcase clock, presented to the Pump Room at Bath, Somerset, by Thomas Tompion in 1709. Combined with it, in the centre, is an annual calendar. A lever in a slot by the 15-minute mark moves the shutter over the winding square to provide maintaining power. The clock runs for a month and has a case of wainscot oak. Tompion made at least three equation clocks with year movements.

by employing a large cam, called an 'equation kidney', because of its shape, which rotated once a year, and operated a hand by a toothed rack and an arrangement of levers bearing on the edge of the kidney. Cams are commonplace now, but at that time, a few years before 1700, the equation kidney was a remarkable invention. The author of it is unknown, but may have been Christiaan Huygens or Robert Hooke, although Thomas Tompion had 'invent' engraved on his first equation clocks.

The indication of the equation was given by a short hand terminating in a representation of the sun, which moves about $16\frac{1}{2}$ minutes to the left or right of a zero position at the top of a dial marked in minutes. The equation dial can be a separate, semi-circular subsidiary dial in the arch as shown in *Plate 66*. Alternatively, it can indicate on a separate dial, where it is combined with another, longer pointer to an annual calendar indicating month and date, as in *Plate 65*. Very rare indeed are equation and annual calendar hands concentric with the hands of the clock. The simplest solution, however, was to give the equation value on a moving annual calendar ring as in *Plate 64*, where it shows through a sector-shaped aperture.

Among the earliest makers of 'equation clocks', as they were called, were Thos. Tompion, Daniel Quare, Joseph Williamson, and George Graham, all of London. Provincial makers followed suit for some of their special clocks made throughout the eighteenth century. Adoption of the Gregorian calendar by England in September, 1752, however, when eleven days of the year were omitted, made earlier equation dials inaccurate.

One of Tompion's equation clocks can still be seen in the Pump Room at Bath, in Somerset. He presented it in 1709 when the Pump Room was new, after he had made several visits there for treatment, presumably with some benefit. It is a month clock and Tompion presented a sundial which was missing for many years but was rediscovered by a horological dealer, Brigadier Meyrick Neilson and presented to the Pump Room in 1971. The clock has its equation work in the arch. A scale of about $16\frac{1}{2}$ minutes is engraved each side of the central O with the words 'Sun Slower' on the left and 'Sun Faster' on the right. A pointer indicates the equation (see *Plate 66*).

During the eighteenth century most owners set their clocks to



OPPOSITE

Plate 67 There is a calendar in the break arch of the dial of this clock in a walnut case by Thomas Bennett of London, c. 1725. The cherub spandrels have become elaborate. The finials are unusual.

local time and kept them to time by the sundial. Noon was when the sun was exactly overhead. As it was overhead later in Bristol than in London, clocks in Bristol showed an earlier hour. In the nineteenth century, when railways spread over the country, special printed tables were provided by the railway companies to convert local time to 'railway time'. Obviously it was impossible to compile a railway time-table according to local times which varied across the country. Mean time at Greenwich was therefore adopted for 'railway time' and general use, and all over the country clocks were adjusted to show the same time – Greenwich Mean Time or G.M.T.

Most longcase clocks from the beginning to the end of the period indicated the date. In places where there were no or few newspapers and when calendars were rare, it was difficult to obtain the date for writing a letter or arranging a meeting. The clock supplied this information – more valuable than knowing the minutes.

The date indication was shown through a small opening in the dial plate just above the figure VI. The opening is usually square or rectangular (see *Plate 68*) but at times round (see *Plate 107*). The numbers from 1 to 31 are engraved round a calendar ring behind the aperture. This ring – a large circular flat band (see *Plate 44*), has thirty-one teeth round the inside edge and is moved one tooth every night by a pin on a gear-wheel that rotates once in twenty-four hours.

Some later clocks have a semicircular opening which exposes half a dozen or more numbers, the correct date being indicated by a small pointer (see *Plates 74 and 83*). These do not have a calendar ring with internal teeth, but a normal disc with pointed external teeth that is moved one tooth a day. A light spring presses on a V-shaped piece (called a jumper) that fits between two teeth. It makes the wheel jump from one date to the next when partly moved by the pin. The pin moves a calendar ring the whole distance, but a jumper is needed on smaller wheels or those that might be altered by friction.

At the end of a month of less than thirty-one days, the calendar ring or disc has to be turned round to 1 by hand, by removing the hood and reaching behind the dial plate. Some clocks, however, have little holes by the numbers so that the calendar ring can be moved on with the point of a pencil after merely opening the hood door.

On many later clocks, particularly those with painted dials, an alternative arrangement was to have the numbers 1 to 31 painted in a circle, like a seconds dial, and to have a hand that was moved daily by the clock to indicate the date. The principle of operation was the same as that of the disc explained opposite (see Plate 47).

Calendar dials in the break arch had a run of popularity, the date being indicated by a hand, sometimes carrying a gilt image of the sun (see Plates 67 and 143). As the calendar disc is remote from the 24-hour wheel that operates it, a pin in the wheel slides in a slot in a long lever, rocking the lever to and fro. The end of the lever moves the disc one tooth every night.

Another arrangement was to have a day-of-the-week dial and hand in the break arch and the date shown through an aperture above VI as described earlier (see Plate 112). The hand indicating Monday, Tuesday, Wednesday, etc., is attached to a 7-toothed wheel behind the dial, which is advanced a tooth at midnight. Occasionally a name-of-the-month dial was also incorporated. This is advanced one position at each revolution of the day-of-the-month wheel. Such a clock therefore displays the month, date, and day of the week as well as the time.

Still a further variation was to employ a centre 'sweep' hand on the main dial, that is, one concentric with the hour and minute hands, to show the date against numerals 1 to 31 engraved on the silvered zone or painted on the white dial as in Plate 69. The 'zone' is the circular area of dial plate inside the chapter ring.

Occasionally a clock has an annual calendar (see Plate 66).

A few special clocks were made, both by London and provincial clockmakers, with perpetual calendars that did not need adjustment by hand at the end of months shorter than thirty-one days, and even compensated for leap years. They may have been more of a tour de force than of practical value because resetting of the calendar if the clock were allowed to stop for long was a tricky task, even for a clockmaker. The specialist in such clocks appears to have been Joseph Williamson, mentioned earlier.

A service provided by many longcase clocks was to show the phases of the moon. When there were no street lights and no torches, only feeble lanterns, it was important to know when there would be a full moon. It was especially important in the towns, where footpads might be abroad, only to venture out after dark in



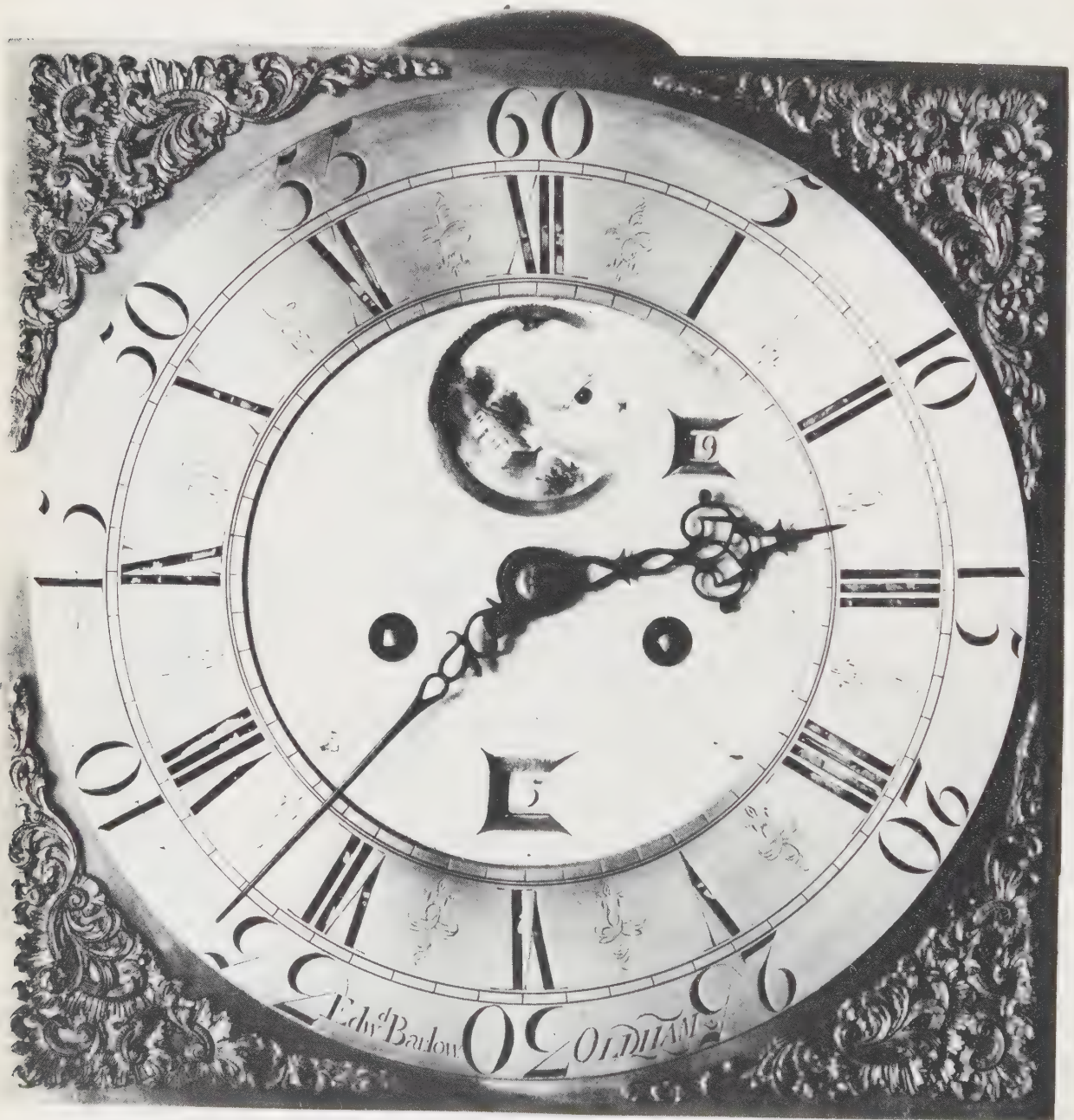

the light of the moon. A number of local customs also depended on the phase of the moon. Seed planting was carried out in some communities when the moon waxed and trees were transplanted at full moon. If shingles were nailed on a roof during the crescent of the moon it was thought that the shingles would warp the way of the moon.

Today few townfolk are aware of the current state of the moon. A century or more ago it was as important a subject as the weather. Clockmakers realized about 1730 that they could provide an automatic almanac on a dial and avoid the nuisance of having to refer to printed tables to find the state and age of the moon. Around mid-eighteenth century the moon dial became very popular.

Present-day owners of moon clocks can put them to a new use – weather forecasting. Research in Australia and the USA in 1962 points to the driest days occurring two or three days before the new moon or full moon and the wettest days two or three days after each.

A lunation – the time it takes for a full cycle of the moon – is 29 days, 12 hours, 44 minutes, 2.8 seconds, or approximately $29\frac{1}{2}$ days. The cycle starts from a ‘new moon’, which is no moon at all, and was shown in the printed almanacs as ●; it went through the first quarter to the full moon, shown as ○, at $14\frac{3}{4}$ days, then through the last quarter to new moon again.

Earlier types of moon dial follow the almanac symbols. A black moon with a ‘man-in-the-moon’ face represents the new moon ●, and a white smiling moon face represents the full moon ○. These two faces are painted diametrically opposite each other on a brass disc about six inches across, and the disc mounted behind a hole the same size as a moon face cut into the dial zone under the numeral XII.

It is obviously impossible to cut $29\frac{1}{2}$ teeth; therefore twice the number of teeth – fifty-nine – was cut around the edge of the moon disc and a tooth was advanced every twelve hours, so that the whole moon disc revolved once in twenty-nine and a half days. The arrangement is shown in Fig. 23. Between the moon faces, coloured scenes of the country are usually painted as in Plate 68, or stars as in Plates 87 and 96; sometimes the moon was engraved (see Plate 74).

OPPOSITE

Plate 68 Dial of a Lancashire clock by Edward Barlow, with the moon at the 19th day of its age. The minute figures are large and the quarters and half hours are still shown, which dates it about 1750. The spandrels are from a trade house of the time. The movement is shown in Plates 44 and 45.



Plate 69 A fine tiger maple veneered case with eagle inlay houses a clock by Jacob Eby of Mannheim, Pennsylvania, dated about 1800. The plinth is bowed. The third concentric hand indicates the day of the month.

The age of the moon was also shown through a small aperture close to the moon dial. The days from 1 to 29 are engraved on the outside edge of the disc opposite every other tooth, with the addition of $\frac{1}{2}$ between 2 and 1.

Although not originating there, this type of moon dial is often called a 'Halifax moon' because so many makers in that area of Yorkshire employed it on their clocks, thirty-hour (see Plate 83), and single hand types as well as eight-day, from 1740 or so onwards. The system of a face behind a hole in a dial is very ancient. It is used, for example, in the Wells Cathedral Clock, set up about 1392; in this case the hole itself moves also, so that the attitude of the moon is correct.

The arrangement tends to confuse because the black moon face can mistakenly be taken to indicate a full moon instead of a new moon. In addition the quarters are displayed with the wrong shape. The next arrangement that came into use obviated the first disadvantage. Both moons were made white and each indicates a full moon. The scenes between them mean new moons. The moon dial, having to turn at half the rate, is advanced a tooth every twenty-four hours.

Next came a system that also showed the correct shape of the quarters. It is also early in origin. Clocks were certainly made with it in the sixteenth century. It lent itself especially to the dial with a break-arch top, where it could be located.

Two moons were still painted on the disc, which was much larger, but both represent full moons. The aperture in the dial is cut with two hemispherical shapes as shown in Fig. 24 and Plates 32, 69, and 98.

At new moon, both faces on the disc are obscured, and only the coloured scenery between them is displayed. As the moon waxes, the disc is turned and shows, on the left, the true shape of the growing first quarter until the full face is disclosed. The full-moon face continues its semicircular path behind the hemispherical part of the dial on the right, continuing to display the correct shape of the third quarter until new moon again, after which the cycle is repeated by the second full-moon face.

More space was needed for this arrangement and although it was at times employed in the zone of the dial (see Plate 123), it was more usual to incorporate it in the break arch, where the

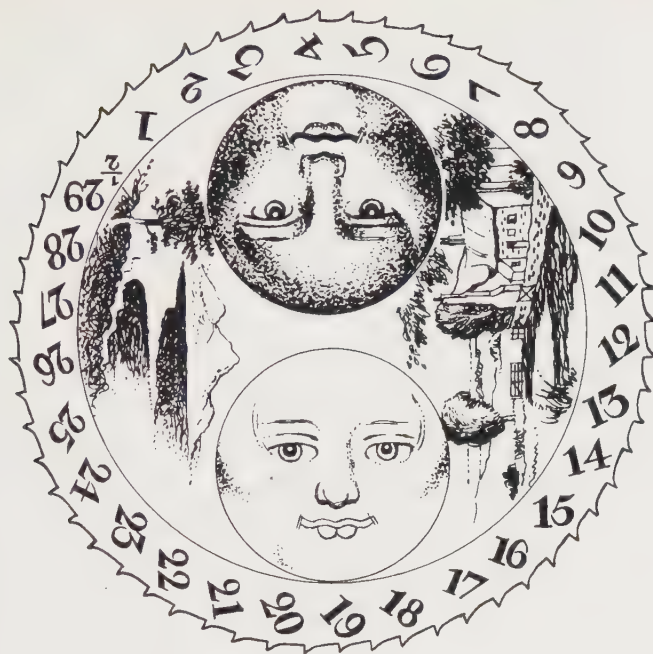

Fig. 23 The basic moon-dial plate with two faces showing full moon and new (no) moon, with scenes between them. They indicated through a hole in the clock dial as on the right. The age, round the edge, usually showed through a separate off-set aperture for reasons of practical convenience.

semicircular shape was so appropriate. A dial with two full moons instead of one, naturally has to turn at half the rate. This was achieved by having $4 \times 29\frac{1}{2} = 118$ teeth, one tooth being moved on every twelve hours.

The age of the moon was shown in the same way by numbers around the silvered edge of the moon disc, but instead of one of these showing through an aperture, the top semicircle of them was exposed and a fixed pointer on the clock dial, in the centre of the moon aperture, indicated the moon's age (see Plate 57).

The earliest moon dials were engraved, but these soon gave way to painted versions in brass dials, then a return to engraved and silvered moons. White dials always had painted moons. A firmament of stars was portrayed around the moon faces at first and this was superseded by scenery – landscapes, seascapes, or both. There are a few clocks with real diamonds (although industrial quality) or paste brilliants set in the dial to imitate stars.

A moon dial on a clock must be set or adjusted independently of setting the time. Also, it must not be adjusted during the short



Fig. 24 Moon dial in the arch of a clock, which shows the correct shapes of the quarters. The age is shown by a central pointer at the top (not indicated in the drawing).

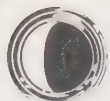

ABOVE

Fig. 25 An effigy of the moon, a half-silvered rotating sphere, half of it projecting through a circle cut in the dial.

OPPOSITE

Plate 70 A most unusual walnut case of a clock by Thomas Ogden of Halifax, who was one of a large family of Yorkshire clockmakers, and one of the few who used a revolving, half-silvered ball to indicate the changing phases of the moon.

period that the clock is operating it. The same remark applies to calendar and other special indications. Almost any pocket diary published today indicates the moon's phases for setting the clock. During a year the moon dial gains about nine hours and it need only be moved a tooth backwards (half a day) by hand yearly to remain accurate enough. Since the mechanism is so simple, moon dials on most old clocks are complete and easily made to work.

Another form of moon dial employed for astronomical clocks in earlier times and some in longcase clocks, around mid-eighteenth century, is a small globe which rotates clockwise to imitate the moon's phases (see *Fig. 25* and *Plates 70* and *96*). Other clockmakers may well have taken the idea from Ahasuerus Fromanteel, who introduced the longcase clock into England and used such a device on top of some of his clocks. The moon globe is half white and half black. It is set in a slightly larger hole in the arch of the dial, so that half of it is exposed, and rotated during one lunation. If the black hemisphere only can be seen, this indicates a new moon. The white side gradually comes into view until the fully white hemisphere indicates the full moon. It is turned round by a shaft from gearing giving the approximate rate of movement of shadow across the moon (which does not in fact rotate in relation to the earth) and should be viewed at eye level from across the room.

With a globe moon, the age is sometimes indicated by numbers round its equator. A fixed pointer over the front shows the age.

Knowing when the moon could supply enough light was very helpful, but it was still necessary to know when the moon rose and set. Even the best clocks could give this information only approximately, but the traveller would have known that the full moon generally rises at sunset and sets at sunrise, while the quarters rise or set at noon and midnight. Thomas Lister's clock dial shown in *Plate 94* includes not only moon rise and set but also sun rise and set.

Another useful piece of information at the time was the state of the tide, for much transport was by boat. The rivers through big cities were crowded with traffic. Even in districts where difficult streams had to be forded, it was necessary to know when high and low water occurred.

The theory of the tides was not understood during the early days of the longcase clock and information about tides was col-

lected by measuring them, which made possible some prediction. John Flamsteed, the first Astronomer Royal, who worked in the Greenwich Observatory built for him on the banks of the Thames downstream from London, measured the Thames tides regularly and, from 1683 to 1688, published figures for London Bridge which were of great value to shipping. After Isaac Newton showed how it was possible to calculate tidal times by conjunctions of the sun, earth, and moon, Flamsteed's tables were no longer issued.

Thomas Tompion made two longcase clocks with dials showing the state of the tide at London Bridge as early as about 1675, but no other clockmaker, as far as is known, followed his lead for over twenty years.

A tidal dial was a rarity until after 1756 when the great self-taught astronomer, James Ferguson, published a simplified explanation of Newton's *Principia* in the manner of today, 'made easy to those who have not studied mathematics', in which was an explanation of the causes of and variations in tides.

Ferguson included a description and drawing of a manually-operated tidal dial he had invented. It was universal and was set to the age of the moon by turning a handle, when it displayed the state of the tide at over two hundred places round a circular plate. The tide was shown by a blue oval-shaped plate, rotated behind the fixed circular plate, the bulges at the ends of the oval indicating high water and the narrow sides low water.

Ferguson's dial also had an arrangement for increasing the bulges of the blue dial to show the higher spring tides (when sun, earth, and moon – new or full – are in line) and neap tides. In 1764 Ferguson incorporated his dial in a clock for the Dock Master at Liverpool and one or two clockmakers copied it, although not with the spring and neap tide refinement (see Fig. 26).

The Dock Master's clock included a fine pictorial working representation of the tide, details of which Ferguson published in 1771, following this two years later by a simplified version, which was used on a number of special clocks.

The pictorial part of one of Ferguson's dials is a painting of two rocks in the arch of the dial. Between the rocks a stretch of blue sea is depicted. The 'sea' is actually a strip of metal painted blue which is raised and lowered by a cam mechanism to coincide with the tide. The cam is large, but oval, unlike the 'equation kidney'.

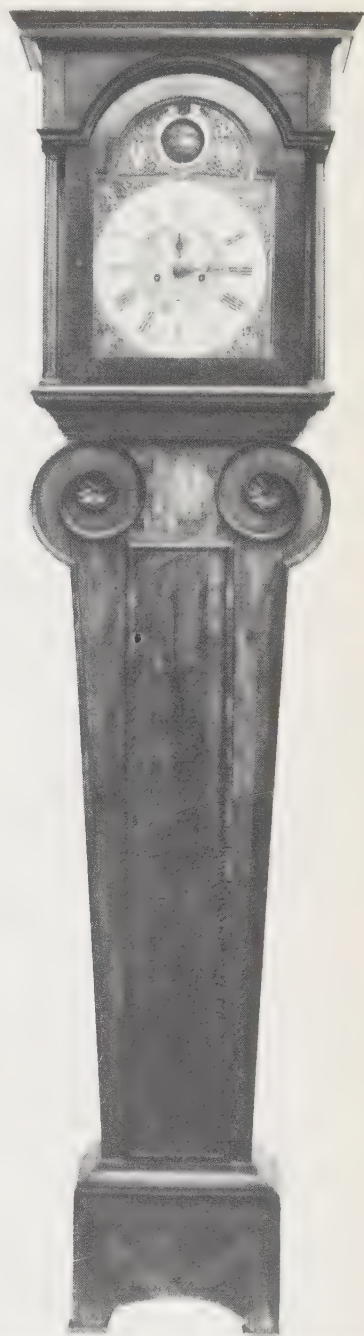

A globe type of moon 'shines' above the water. At the bottom corners below the main dial are two subsidiary dials. One gives the age of the moon and the hours and minutes of high tide. The other indicates different states of the tide by a hand and the oval-shaped disc already described.

It then became known to clockmakers that the main influence at work was the moon, and, by allowing for location and local conditions, a tidal dial could be associated with a moon mechanism. During one lunation of twenty-nine and a half days, the time of high tide changes through twenty-four hours, i.e. high tide comes about forty-eight minutes later every day. An age of moon dial can therefore be calibrated to indicate times of high tides. Suppose the age of moon dial is divided into one to twenty-four hours as well as one to twenty-nine and a half days. If, when the moon is full, high tide locally is at 3 p.m., the hour of three is placed opposite fourteen and three-quarters day (the time in the lunar month when the moon is full).

Every twenty-four hours, the age of moon dial is advanced by the clock to the next day number. The same pointer will therefore

Fig. 26 Ferguson's tidal dial, incorporated in some longcase clocks. A blue plate between 'cliffs' rises and falls to represent the tides. This drawing is based on one in Britten's *Watch and Clockmakers Handbook*.

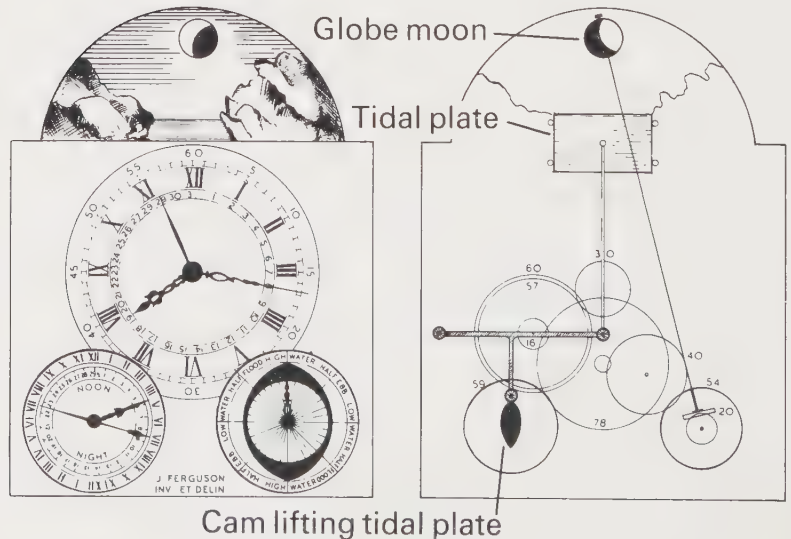

also indicate forty-eight minutes less on the ring of hour numerals, that is the time of high tide on that day. It should be noted that such a simple tidal dial can only be made for one place.

The hours were marked in Roman figures – as was usual – to distinguish them from the Arabic age of moon dials and were I to XII repeated, instead of I to XXIV, again following normal practice. Fig. 27 shows a tidal and age of moon dial. Sometimes it was in the arch as in Plate 20.

An age of moon and tidal dial of the type just described is easily made universal so that it can be set for any tidal waters. The tidal indication is constructed as a separate ring held friction tight to the age of moon dial. If, then, it is adjusted so that III is under the fourteen and three-quarter days, the age of the full moon, as described earlier, this is correct for London Bridge. If it is turned so that XII is under fourteen and three-quarter days, it will be correct for Dover.

Those who sail or live near the sea will wonder about the other high tide, for there are two every day at most places, but, by having one time indicated, it is easy enough to add 12 hours 25 minutes to know the next. The double XII hour divisions make it easier to estimate the time of the next tide.

A more accurate tidal dial was a separate indication with three rings of numbers and two hands below 12 o'clock on the dial. The inner ring shows twenty-four hours I to XII repeated, and the outer one minutes up to sixty. The two hands give the hour and minutes of high tide. The third ring of figures is the familiar 0 to $29\frac{1}{2}$ on which the age of the moon is read from the 'hour' hand.

Striving after novelty towards the end of the eighteenth century, some clockmakers, particularly those in the West Country, introduced moving figures into the arch of the dial. Clocks with such automata were popular in Holland. Two are shown in Plates 122 and 123. The automaton was operated by a wire from the arbor of the anchor escapement, which did nothing to improve timekeeping. Favourites were a ship tossing on the sea and Father Time swinging from side to side. Boxers swung at each other, children rocked on a see-saw, or men sawed wood. Also popular were a painted female face in which the eyeballs rolled unnervingly from side to side, a hovering bird, a hawk after a chicken, a swan feeding, and Adam and Eve reaching for the forbidden fruit.

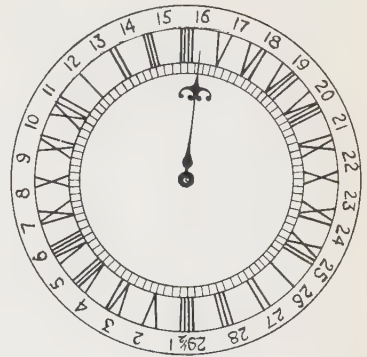

Fig. 27 A tidal dial combined with an age-of-the-moon dial, in this case indicated by a moving hand instead of a moving dial. The hand indicates the time of one high tide as well as the moon's age.



CHAPTER EIGHT

THIRTY-HOUR
AND
ONE-HAND
CLOCKS

The lantern clock did not vanish when the longcase clock appeared on the horological scene. It continued to come from workshops in its same four-posted form with an unprotected brass dial and one hand, brass doors between the posts at the sides, feet at the bottom, and finials and ornamental frets at the top enclosing the balance-wheel below the bell.

Fromanteel's dramatic advertising announcement about the pendulum 'regulator' caused lantern clocks soon to appear with a short pendulum at the back, or even inside, instead of a balance-wheel at the top. The crown-wheel for the horizontal verge escapement was positioned where the balance-wheel had been and the original vertical crown-wheel was replaced by a similarly shaped gear-wheel driving through a right angle and called a 'contrate-wheel'.

The long pendulum was also gradually adopted by lantern clockmakers after it was invented. A lantern clock with a long pendulum hanging from the back is incongruous to the eye, but was nevertheless made that way at the time or modified from a balance controlled version during the period. The escape-wheel of the anchor escapement is positioned where the vertical crown-wheel used to be.

The growing number of lantern clockmakers in provincial towns, as well as in London, undoubtedly became aware of the strong attraction of the new longcase clocks. It was simple enough to mount a lantern clock in one of the fashionable tall cases made of wood, so that they did just that (see Plates 2 and 3). Lantern

clocks suffered from the disadvantage that they had to be wound at least once a day, but an owner's time was not then at such a premium as his money and posted frame clocks could be made at prices that were well below those of the new plated clocks running for eight days at a winding. London makers, including the finest such as Thomas Tompion, were offering longcase clocks with posted 30-hour movements, as well as 8-day ones with plated movements, soon after Ahasuerus Fromanteel introduced the classic tall clock. One by Joseph Knibb is shown in Plates 76–78.

London makers in general gave up the posted frame 30-hour movement around 1700, although a few experimented from about 1670 with plated movements for 30-hour clocks. Provincial makers alone continued with the posted frame after the turn of the century and the style became so entrenched that plated 30-hour clocks were not at all common, at least in southern England, until the last quarter of the eighteenth century. Since lantern clocks usually had one hand, it might easily be assumed that a longcase clock with two hands has a plated movement. The reverse is often the truth. Sometimes posted movements were made with two hands and plated movements with one. The design depended entirely upon the local clockmaker, the extent of his skills, and the demands of his customers.

Returning to the first posted frame longcase clocks, the round chapter ring of the lantern clock was mounted on a square dial plate in order to fit the square opening of the hood of the longcase clock. The dial then looked very similar to that of an 8-day clock. The dust-protecting side doors and back of the lantern clock were omitted as unnecessary, as were the decorative finials, ornamental frets, and four bell straps – although not always (see Plates 72 and 73). The single hand remained (see Plate 71).

The earliest 30-hour longcase clocks had verge escapements and short pendulums like the first 8-day versions. The drive was not changed, so that one weight powered the timekeeping and another the striking. Each was hung by rope or chain which went over a pulley in the clock and was kept in the groove by a small counterweight on the other end of the line. The timekeeping pulley was in the front of the movement and the striking one behind it (see Plates 72 and 73).

Some early posted movements had alarms in addition to, or



Plate 71 The one-hand striking clock with a brass dial in an oak case was popular all over the country for a long time. John Groome of Colchester made this early one about 1675. Note the cherub and crown spandrels and engraved zone.

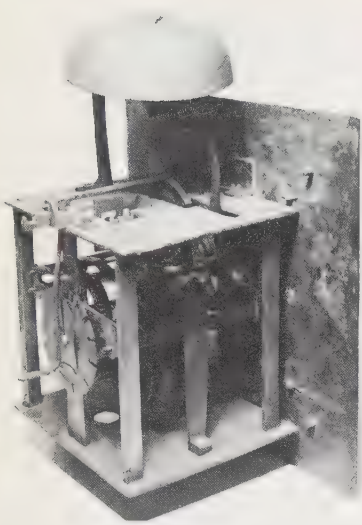

Plate 72 The decorations carried over from the lantern-clock movement were discarded when the posted movement was generally adopted for 30-hour longcase clocks. This one has an anchor escapement, and is for long pendulum operation.

instead of, the striking work, which required another, smaller, weight to drive it. The alarm mechanism was situated on the side of the movement, where it is sometimes found in the true lantern clock. (The greater proportion of 'lanterns' had alarms mounted on the rear of the case, but this was impractical when a pendulum was fitted.)

Huygens' new invention of the endless rope drive (see Fig. 4) was quickly seized upon by posted frame clockmakers because it was relatively easy to adapt a clock to take it and it improved the timekeeping by providing maintaining power to keep the clock going while it was wound. The clock stopped during winding with the old method of pulling up the weight, or at least lost time. Both ropes and chains seemed to have been used from the beginning. If a line is missing from a clock, the pulley groove indicates what it should be. Pulleys for ropes sometimes, but not always, have spikes around the groove to stop the rope from slipping. The traditional rope, by the way, is of woven linen or cotton thread, not a laid or twisted rope made of hemp. Pulleys for chain drive have the grooves shaped to fit the alternate links of the chain, which lie at right angles to each other. Sometimes these pulleys, too, have short spikes to enter the links of the chain that lie flat.

Clocks designed for endless rope drive have both trains of gears and pulleys turning in the same direction with the single weight on one side (see Plate 73). The other loop of rope (or chain) on the other side sometimes has a ring-shaped weight round it which lies at the bottom of the case when the clock is wound up and helps to keep the lines in the pulley grooves when the weight is near the bottom of the case.

In 30-hour clocks which have been converted from separate weight drive, the endless rope or chain is taken over the front pulley and over the back pulley, which drives in the opposite direction, so that the single weight hangs in the middle of the clock. (The object of the opposite directions of drive was to keep the two weights apart and to keep the lantern clock in balance when hung on the wall.)

When a clock was designed for endless rope operation, the great wheel of the timekeeping side, to which the pulley is attached, turns once in two and a half or three hours. Clocks designed for two weights had this great wheel turning in an hour.

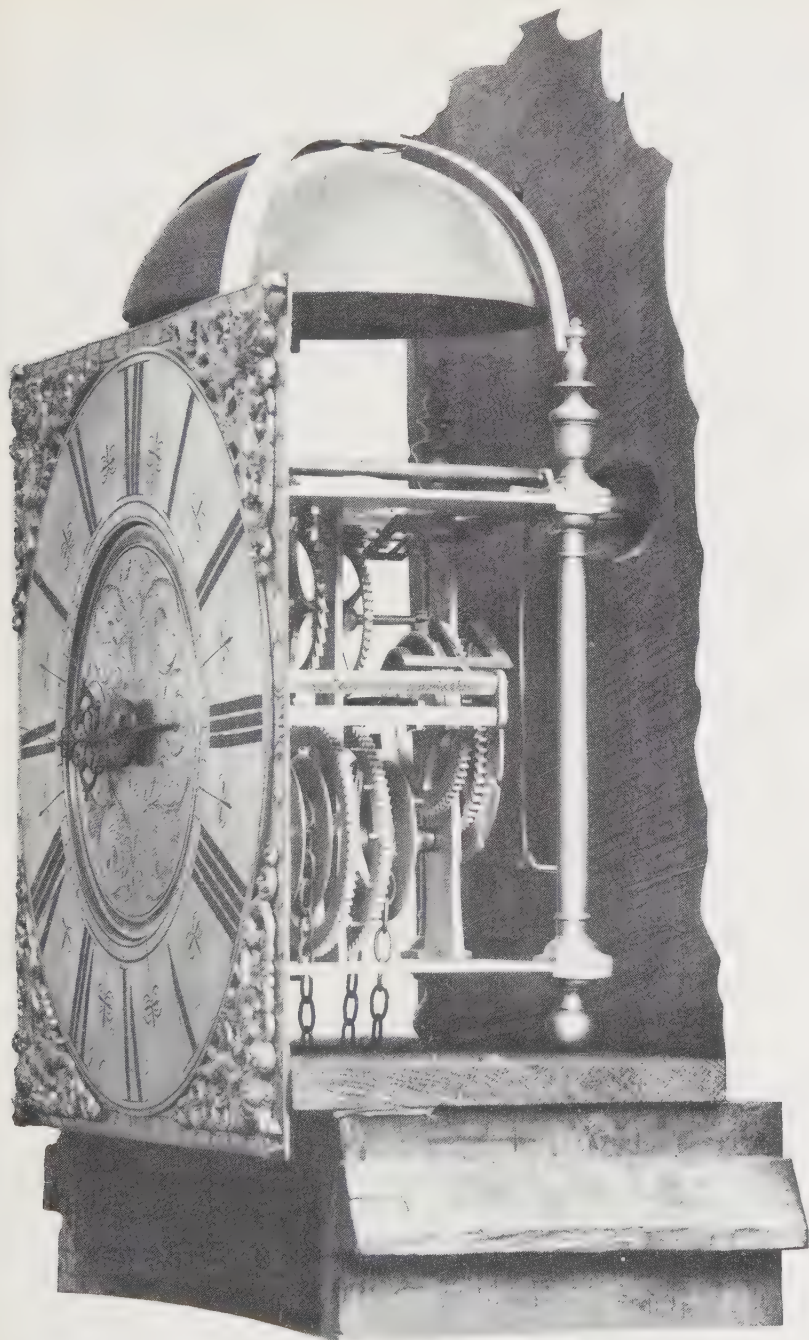

Plate 73 The movement of the clock shown in Plate 71 still has the bell straps of the lantern clock, as well as its feet and finials on the top corners.

RIGHT

Plate 74 The dial of the 30-hour clock in *Plate 79* by Thomas Lister Senior, of Halifax, Yorkshire. The upper circular hole exposes a Halifax-style silvered moon, with the moon's age below it. In the lower part of the dial is a calendar. The hands are exceptional; they are original and of brass. The date is c. 1750–60.

OPPOSITE

Plate 75 One-hand 30-hour clocks were at times mounted in fine cases such as this lacquered one. The clock, which has an 11-inch dial, was made by John Smorthwait of Colchester in about 1710.



As a single weight drives the striking as well as the timekeeping with the Huygens system, the weight descended rather rapidly and would not give a full day's working. Clockmakers got over this by modifying the striking train of gears so that it did twice as much work through the same number of turns. This meant doubling the number of pins round the striking great-wheel (the wheel attached to the striking pulley) that operated the hammer. It also meant putting two gaps in the hoop-wheel instead of one and modifying the count-wheel as well.

A clock with pull-up winding, as the system is sometimes called, should be easily recognized as there are no winding holes in the dial (see *Plate 74*). Not infrequently, however, clockmakers in some northern areas made 30-hour clocks with pull-up winding that had dummy winding holes to make the clock appear more expensive (see *Plate 83*). This was a particular feature of Halifax

and Lancashire makers. The brass dials had the normal two holes behind which were mounted false winding arbors. The same practice, using dummy winding squares, was carried on with some painted iron dials from after 1770, but even that became too expensive and, from some years before 1800, dial makers embellished some dials by *painting* holes and winding squares on them.

A few 30-hour clocks were made in the early days with plated movements and key winding through the dial. A few more probably appeared through the years as specially made pieces. Contrariwise, a few clocks appeared around the 1670s with pull-up winding and ran for eight days. One was made by Thomas Tompion. French makers in the eighteenth century frequently made rope driven pull-up 8-day clocks, many of which were precision timekeepers.

With the changeover to the long pendulum, the brass parts of the lantern style of movement (see Plate 73) were replaced by parts made of iron, in particular the corner posts and occasionally the top and bottom plates (see Plate 72). The reason was economic. Brass was becoming more expensive than iron. Although the long pendulum brought the minute and the seconds hands to the 8-day clock, it did not even bring the minute hand to most 30-hour clocks. One reason may have been that only more sophisticated owners were able to cope with the new-fangled concentric minute hand.

Although reading the time seems so simple today, it has to be consciously learned by children and adults can still make mistakes. In the eighteenth century, another hand superimposed on the more or less familiar hour hand was undoubtedly confusing to many people. Many probably considered it an affectation to have a minute hand when perhaps an hour's grace was allowed for appointments and those wishing to catch a stage coach would arrive hours, even a day, before it was due to leave. Indeed the coach itself could be a day late. Pickfords record having lost an entire coach and horses in the mud in the early eighteenth century!

Clocks with a single hand persisted throughout the century. Plate 75 shows a fine one. Thirty-hour clocks with two hands were made in London during the last forty years or so of the seventeenth century, but they do not appear to have caught on in the

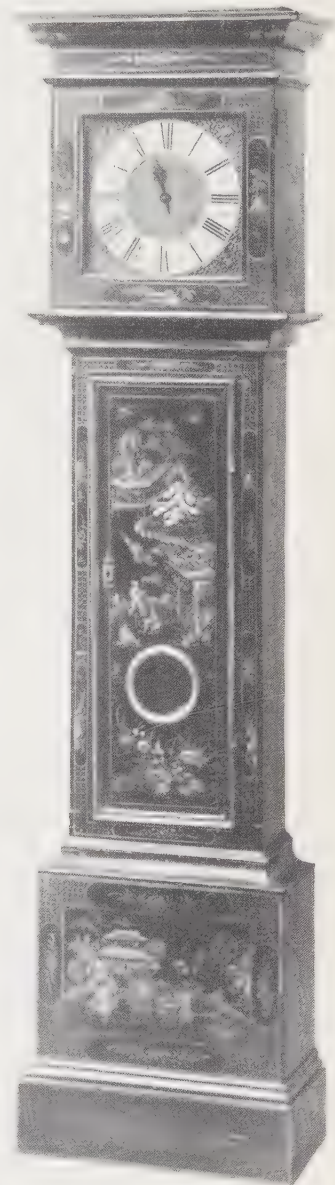

provinces in any numbers until half way through the next century, perhaps until as late as the 1770s when the white dial had provided a big boost to the making of longcase clocks in towns and villages all over the country (see Plates 79–82). Many one-hand clocks were also converted at this time to two hands by adding the 12 to 1 gearing called ‘motion work’. It seems that conversion sets consisting of the extra wheels and the pipe needed, were available in rough cast brass ready for finishing from trade suppliers. If the dial is not changed, the conversion will be evident from the fact that there will be no minute markings on it – no divisions into five between the hours.

The movement of a 30-hour clock is substantially different from that of an 8-day. The time train of an 8-day – the train of gears responsible for turning the hands – has four wheels in it. The main-wheel is attached to the barrel around which the gut of the driving weight is wound. It is at the bottom right from the front. The main-wheel drives a toothed pinion attached to the centre-wheel which drives the hands. The centre-wheel drives a pinion on the third wheel and the third wheel drives a pinion on the escape-wheel, the arbor (shaft) of which carries the seconds hand. This arrangement has four arbors with wheels and is sometimes referred to as a ‘four-wheel train’ (see Fig. 8). The minute hand turns with the centre-arbor through a simple friction or clutch drive and in turn drives the hour hand through the motion work.

A 30-hour movement has a three-wheel train. The main-wheel arbor carries the pulley driven by the weight. It drives a pinion and wheel directly above it. This wheel is equivalent to the third wheel in the train of an 8-day clock and is given the same name although it is in fact the second wheel in the train of gears. It drives a pinion on the escape-wheel just like the third wheel of the 8-day clock (see Fig. 28). There is one major difference, however. The escape-wheel of the 30-hour clock turns anti-clockwise, which is why no seconds hand is fitted to it normally. There are one or two about with seconds hands that turn backwards. A number have date hands that turn backwards, but that did not seem to matter as the hand is not seen turning.

There is no centre-wheel in a three-train clock. The single hour hand of one-hand clocks is attached to a wheel called the ‘hour-

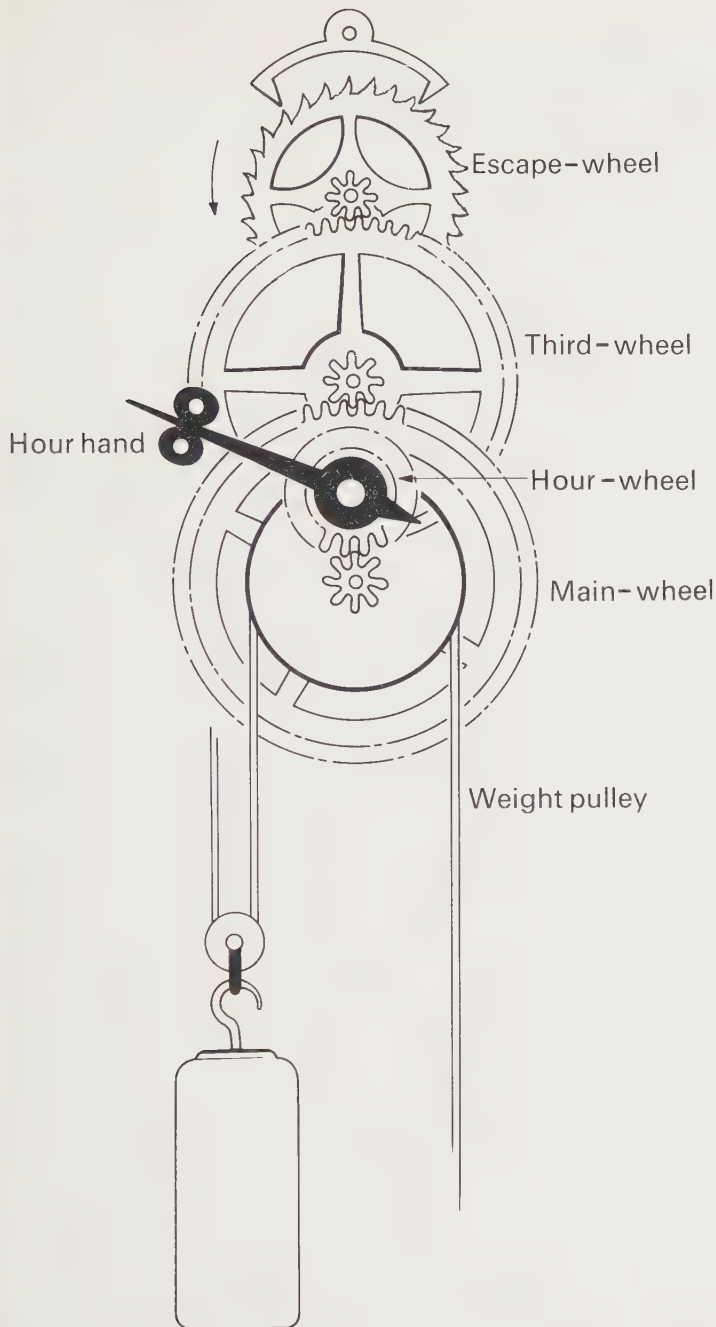

LEFT

Fig. 28 The three-wheel train of a 30-hour clock. The great-wheel turns in $2\frac{1}{2}$ –3 hours and drives the hour-wheel, which turns once in twelve hours.

BELOW

Fig. 29 Motion work for a two-hand, 30-hour clock, which is the same as motion work for a clock converted from one hand. The great-wheel, turning in an hour, drives the minute-wheel, which drives the minute-wheel pipe. The hour-wheel is driven from the pinion of the minute-wheel.

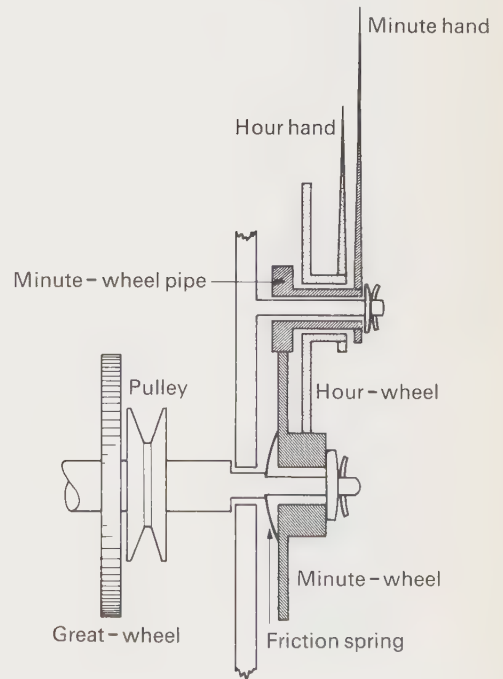

OPPOSITE

Plate 76 The finest to the simplest makers constructed 30-hour clocks. This was made by Joseph Knibb, London, about 1675. The narrow oak case is 8 feet 10 inches high, and the dial only $9\frac{1}{2}$ inches square.

wheel' running on a post riveted to the central bar of the posted frame. It is driven from a pinion on the end of the main-wheel arbor below it. If a minute hand is fitted, it is always rather slack because it is driven indirectly in the same way as the hour hand and not directly from the train. It may have as much as a minute's play. Samuel Harlow, writing in 1813, called these 'shake minutes clocks'.

When a one-hand clock is converted to two, an extra wheel is attached to the main-wheel arbor behind the hour pinion. This drives a new pinion on the same post as the hour-wheel, attached to the minute hand. The hour-wheel has to be different because it now runs over the tube carrying the minute hand instead of directly on the post. A conversion set comprised an entirely new set of parts, the original ones being discarded. As new two-handed clocks were made in exactly the same way, it is almost impossible to tell whether a 30-hour clock has been converted or not, especially if a new chapter ring was engraved and fitted at the same time (see Fig. 29).

The striking train of a 30-hour clock also has one fewer wheels than an 8-day, in which there are four – a main-wheel and barrel turned by the driving weight, which drives a pin-wheel to operate the bell hammer (see Fig. 8). This drives the hoop-wheel, which in turn drives the warning-wheel. There is one extra arbor carrying a fly to control the rate of striking, driven by the warning-wheel. In a 30-hour train, the main-wheel and pin-wheel are combined, to reduce the number of wheels to three. There is still the extra arbor carrying a fly. The number of blows struck on the bell is increased at each turn by doubling the number of pins, as explained earlier.

A summary of the main visual differences between 30-hour plate frame movements and 8-day movements will help to distinguish them easily:

1. They have one wheel fewer in each train.
2. They have spiked pulleys instead of grooved barrels for the weights.
3. Examined from the front, with the dial removed, the going (timekeeping) train is on the left in 30-hour clocks with plated frames and on the right in 8-day clocks.

The reason for the change-over of the gear trains is

because the going great-wheel has to revolve anti-clockwise to drive the hands clockwise. The striking great-wheel must also revolve anti-clockwise, otherwise it would draw the hammer into the movement instead of lifting it away from it. Furthermore, if the two great-wheels revolved side by side in opposite directions, they would cause the slack part of the rope to form a widely divergent angle which might interfere with the fall of the weight. (Many plated frame month clocks are also made with the positions of the trains reversed, that is with the striking train on the right like a 30-hour clock.)

Hour striking is normal in 30-hour clocks. In an 8-day clock, the striking is released at the hour by a pin on a wheel turning once an hour. For a 30-hour clock with two hands, the striking is let off similarly, but by a projecting piece. When a clock has one hand, however, there is no convenient wheel turning once in an hour, only that to which the hour hand is attached, which turns once in twelve hours. Such clocks have a star-wheel with twelve points fixed behind this wheel and turning with it. The points of the star-wheel release the striking mechanism every hour.

In almost every 30-hour movement, the number of blows struck on its bell is controlled by a count-wheel, as described in Chapter Four. The design of the movement seemed to resist change to the better form of rack striking that was adopted by makers of longer going clocks. Undoubtedly a local maker could, by adhering firmly to established principles, produce clocks that were economical in price and provided good timekeeping and exceptional reliability, which were what his customers wanted. Many of these clocks are still going and giving a fine account of themselves today, a couple of centuries later, with little attention beyond casual oiling. Neither the customer nor the clockmaker had much reason to change. Change for the sake of change or to save a little time was a concept that would have seemed ludicrous to most ordinary people. There are 30-hour clocks with rack striking but they are few in number. Although rack striking was a considerable improvement over the earlier system, there was resistance to change for both bad and good reasons.

It has already been explained why a 30-hour clock does not have a seconds hand. Another reason was probably that given for

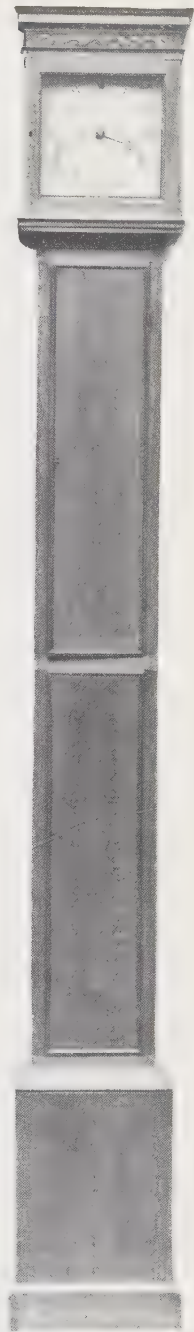
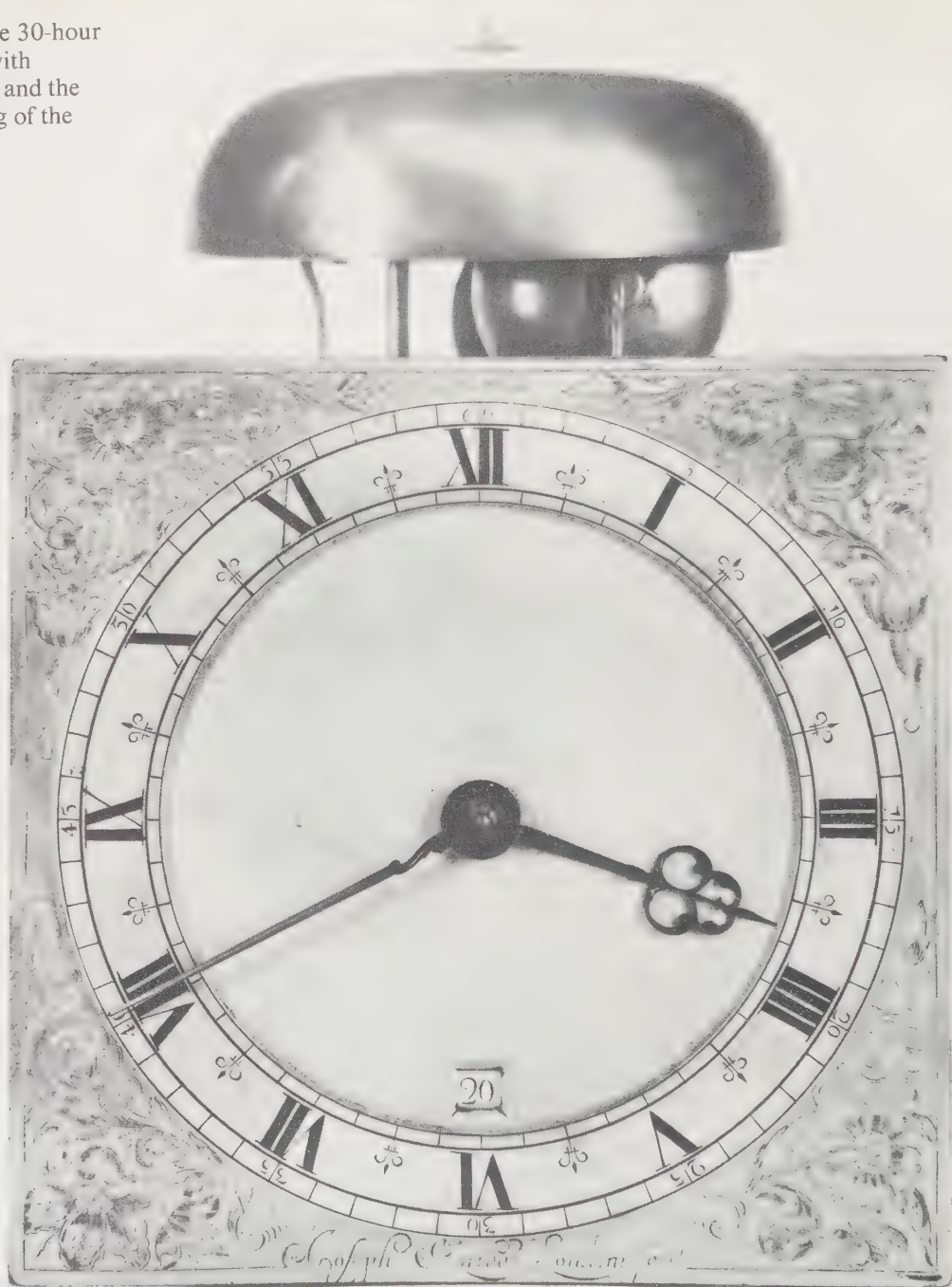

Plate 77 Dial of the 30-hour clock in Plate 76, with engraved spandrels and the narrow chapter ring of the time.



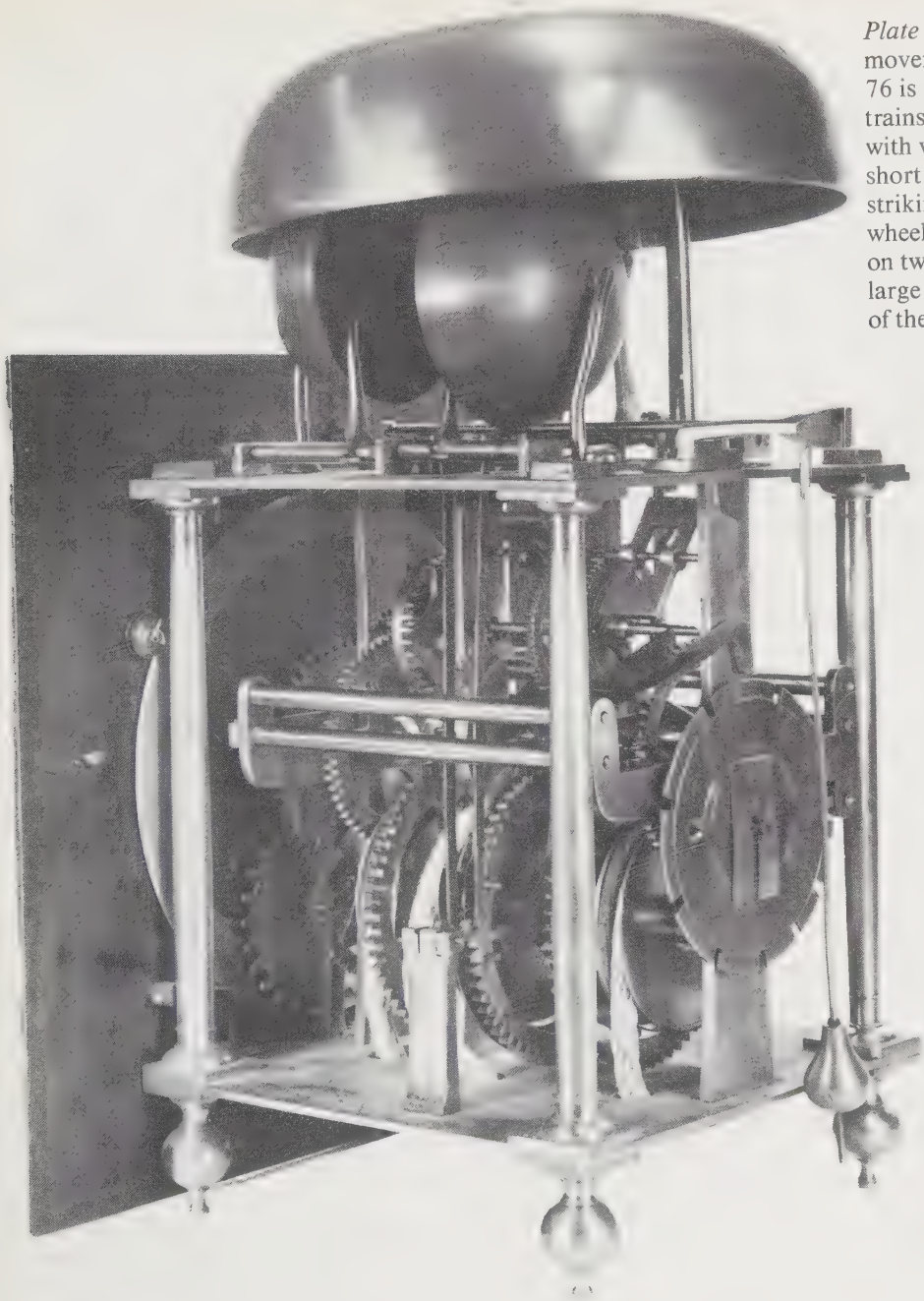

Plate 78 The 30-hour movement of the clock in Plate 76 is posted, and has three trains of gears for timekeeping, with verge escapement and short bob pendulum, for striking, with outside count-wheel, and for quarter chiming on two bells, below the extra large hour bell. Note the rope of the pull-up winding.



the absence also of a minute hand on so many clocks – that it was an unnecessary complication.

Without a seconds hand, it was not necessary for the pendulum to beat seconds so that the escape-wheel jumped forward at every tick and completed a circle in a minute. In fact, most brass dialled 30-hour clocks do not have seconds pendulums. In many, the pendulum is about two inches shorter. Not infrequently it was made longer, perhaps so that it swung more slowly and the power of the weight lasted a little longer. One obscure clockmaker of the early eighteenth century, Samuel Hammond of Battle, made clocks with 45-inch pendulums and escape-wheels with thirty-five instead of thirty teeth, to achieve this end. Of course, the gearing – the ‘count of the train’ – had to be altered. It may be that in some cases the toothed wheels that the clockmaker was able to cut dictated the length of the pendulum.

A day-of-the-month calendar was more useful than a seconds or even a minute hand, so it is commonly found on one-hand as well as two-hand 30-hour clocks. The large ring type of date indicator is found on earlier clocks with brass dials, as well as the smaller disc, and also the small dial with a hand that looks like a seconds hand. These were described in Chapter Seven. The dial method of date indication is common on 30-hour clocks with white dials. It is located over the VI hour in the lower part of the zone. The days are usually numbered clockwise from one to thirty-one and the hand is moved around midnight in the same direction. The hand is usually a little more ornate than a seconds hand. The other common arrangement was a semicircular opening behind which a painted disc with the days of the month was moved anti-clockwise every twelve hours. As several numbers are exposed, the actual date is shown by a small pointed projection in the middle of the top of the slot.

Cases of the early 30-hour clocks do not seem to have been downgraded because of their lower priced movements, or, if they were, it was not to any significant extent. Often the cases were of fine veneered burr walnut during the period in which it was fashionable, or in marquetry or elaborate Japanese lacquer when fashion favoured these. Later, during the mahogany period, some exceptionally well-made mahogany cases were provided to house pull-up movements.



OPPOSITE

Plate 80 Large numbers of painted white-dial clocks were made with 30-hour, as well as 8-day movements. This one has a 30-hour movement, and stands 7 feet high. The well-made case has mahogany trim and swan's-neck cresting and quarter pillars on the front edges of the trunk. It is signed by Richard Morland of Kirby Malzeard, Yorkshire, and was made c. 1800–1810. The dial is shown in Plate 59.

FAR LEFT

Plate 79 Another 30-hour clock with two hands in a good quality oak case, which is about 6 feet 8 inches high. The clock is by a Yorkshire maker, Thomas Lister of Halifax. It has a Halifax moon and a calendar. The dial is shown in Plate 74. Most 30-hour clocks were shorter than 8-day clocks.

LEFT

Plate 81 This looks like an 8-day clock because of the winding holes in the dial. In fact, they are false, and the clock runs only for thirty hours and has pull-up winding. Joseph Batty of Halifax, Yorkshire, was the maker between 1770 and 1780. It has a Halifax moon. See Plate 83 for the dial. The case is of oak, with mahogany trim and bracket feet in the front only.

OPPOSITE

Plate 82 A 30-hour clock in a well-proportioned oak case by Nathaniel Hedge Senior of Colchester. It has two hands and a calendar. Note the absence of winding holes, and the splats at the back of the hood. It is dated about 1752.

In general, as time went by, however, oak became the wood usually used and the more economical the movement, the more economical the case. Oak was preferred probably because it was most suitable for homes in the country where most furniture was of oak or elm. In the eighteenth century, oak was more available than other woods to the local carpenter and joiner who constructed cases; it was normally cheaper than imported woods. Its disadvantage was that it could not be undercut in the same way as mahogany and other finer grained woods, which made fine work more difficult.

Cases were usually shorter than those for 8-day movements, and the hoods were usually set up in a farmhouse or cottage that had lower ceilings than a town house. Again, every general rule has exceptions and it is accurate only to refer to trends or majorities. Thirty-hour clocks are found with crested tops, domed tops, pagoda tops, break-arch tops, and even with hood ornaments such as balls or allegorical figures surmounting the hood. Although most had no feet, they are found also with bun feet, bracket feet, splay feet, contoured apron between the feet, and other variations (see plate 81). Most case styles of longer going clocks were reflected in at least some of their less expensive counterparts.

A clock bought secondhand or handed over to a member of the family when the owner died would sometimes be found too tall for its new home. Since it had no antiquarian value then, it would quite sensibly (at the time: 'ruthlessly' we might say now) be cut down to fit. Some cresting at the top might come off, or the decorative horns cut down or removed altogether. Alternatively the feet would be sawn off. This might mean sawing off the end of the backboard as well when there were front feet only. Sometimes six inches or more was sawn off the bottom of the plinth itself, which made it look out of proportion with the rest of the clock. Cases that have received this treatment – sawing the bottom off – were not necessarily shortened to fit into a room. In those days the walls and floors of many houses were damp. In addition, stone and brick floors laid on the earth were cleaned by swilling them with water. Furniture, including clocks, commonly suffered from rotting feet or bases.

The earliest 30-hour cases were narrow until the first quarter of the eighteenth century had passed, when they grew wider, but not

to the widths of the 8-day clock cases because the height was still restricted. The proportions were decided by the local woodworker supplying the clockmaker, perhaps in consultation with the clockmaker, and therefore varied considerably. Nevertheless, they were made of well-seasoned wood with skill and care, as was the furniture of the time. And they were made to last.

The best locally-made cases would have been constructed by a joiner or carpenter who was a joiner. The carpenter's work was described as 'hammered-up' while the joiner was responsible for framed work and articles made with panels to allow the wood to respond to changes in temperature and humidity without stress. The earliest clocks with long cases had panelled trunks. Trade guilds controlled the division of labour (today sometimes the cause of 'demarcation' disputes) and as early as 1623 the joiner's work was widened to include dovetail joints. Mortice and tenon joints are commonly found in the door frames of clock hoods.

Just before the nineteenth century was ushered in, Napoleon was engaged in Egypt, trying to cut England's trade with India. There were soon problems in the supply of English oak, which was being commandeered for building warships. Carpenters and joiners had to turn to the so-called 'softwoods' that were imported, such as pine, fir, or spruce. Wood from deciduous trees is called 'hardwood' although it is sometimes softer than softwood from evergreen trees. Softwood is sometimes called 'deal' although the word truly means a thick board or plank of pine, fir, or spruce.

To save oak, cases were made with softwood backboards, then the supply of oak became so difficult that whole cases were made of 'deal'. The softwood case was usually finished by filling any splits and knot holes as well as pin holes with knotting, then treating it with primer and painting it. The finish was usually with the two-tone paints occasionally called 'scrumble', treated before the darker top coat had dried with an old brush or rag to imitate a grained wood, usually oak or mahogany. Occasionally the case was stained and varnished. It is fashionable today to strip painted clock cases in the same way as softwood ('whitewood') furniture in a caustic soda bath, and then to wax the wood with Mansion polish or to treat it with polyurethane matt varnish. The result is then euphemistically called 'stripped pine'. It is not restoration,

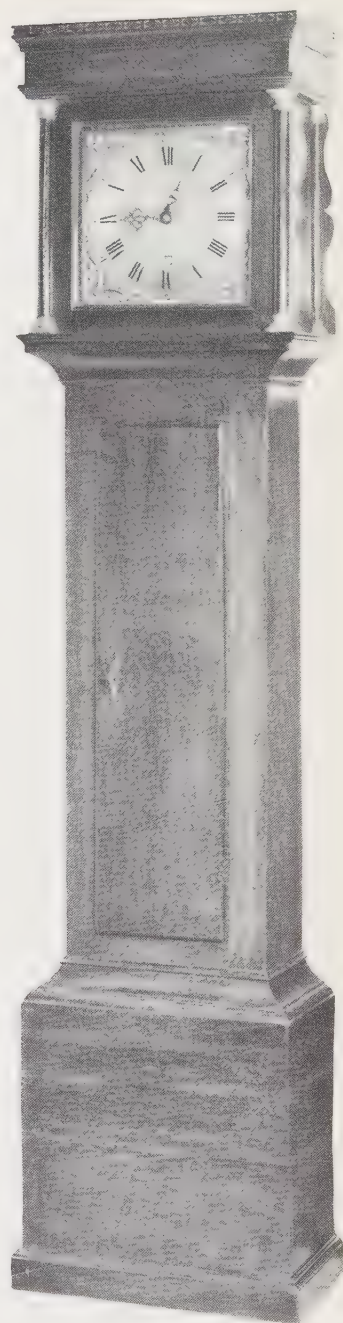

although the result may be more pleasing to the modern eye than the original, and today often rather tatty, graining.

Dials followed the same general sequence as those of 8-day clocks. At first they were of brass, the square dial plate having a separate and circular chapter ring attached by four feet projecting through four holes in the dial plate and held there by taper pins through the feet. In the corners were separate cast and gilded ornamental spandrels, each held by a screw through the dial plate. Engraved decoration of scenes on the zone (the centre) seem to have persisted longer than on 8-day clocks, where matting was favoured from an early time. The main difference was the absence of minute divisions around the outside of the chapter ring because of the one hand, the absence of winding holes except where false ones were provided (see Plate 83) and the absence of a seconds hand. Even a false seconds hand was sometimes fitted for effect and a few clocks with three-wheel trains had an extra idler-wheel between the second- and escape-wheels so that the escape-wheel turned clockwise and it was possible to fit a seconds hand indicating true seconds.

In the last quarter of the eighteenth century, some clocks were made with one-piece brass dials silvered all over. They were not as expensive as the traditional brass dials and were more acceptable to some customers than the painted dial of the time. Many all-over silvered brass dials and the silvered chapter rings of traditional brass dials appear today as bright polished brass because the silvering has been polished away, or have blackened areas of silvering because the silver has tarnished.

The painted dial for 30-hour as well as 8-day clocks followed the sequence described in Chapter Six from its introduction about 1770. It is possible that the painted dial assisted the introduction of two hands for 30-hour movements since it was taken up with enthusiasm for all types of long case by clockmakers in many parts of the country and in the north in particular, who popularized the white dial longcase clock at a time when London clockmakers, with few exceptions, had lost interest in tall clocks.

As a last comment, the Leicestershire clockmaker, Samuel Deacon, working in the later eighteenth century, recorded in his notebooks that he could make a 30-hour clock in twenty-nine hours. It would be an exceptional feat for anyone to do so today.

Plate 83 A brass dial with indications similar to those in Plate 74, yet there is an important difference. It looks like the dial of an 8-day clock, but the winding holes and squares are false. It is from the 30-hour clock with pull-up winding by Joseph Batty of Halifax, Yorkshire, shown in Plate 81. The arch is separate from the dial.

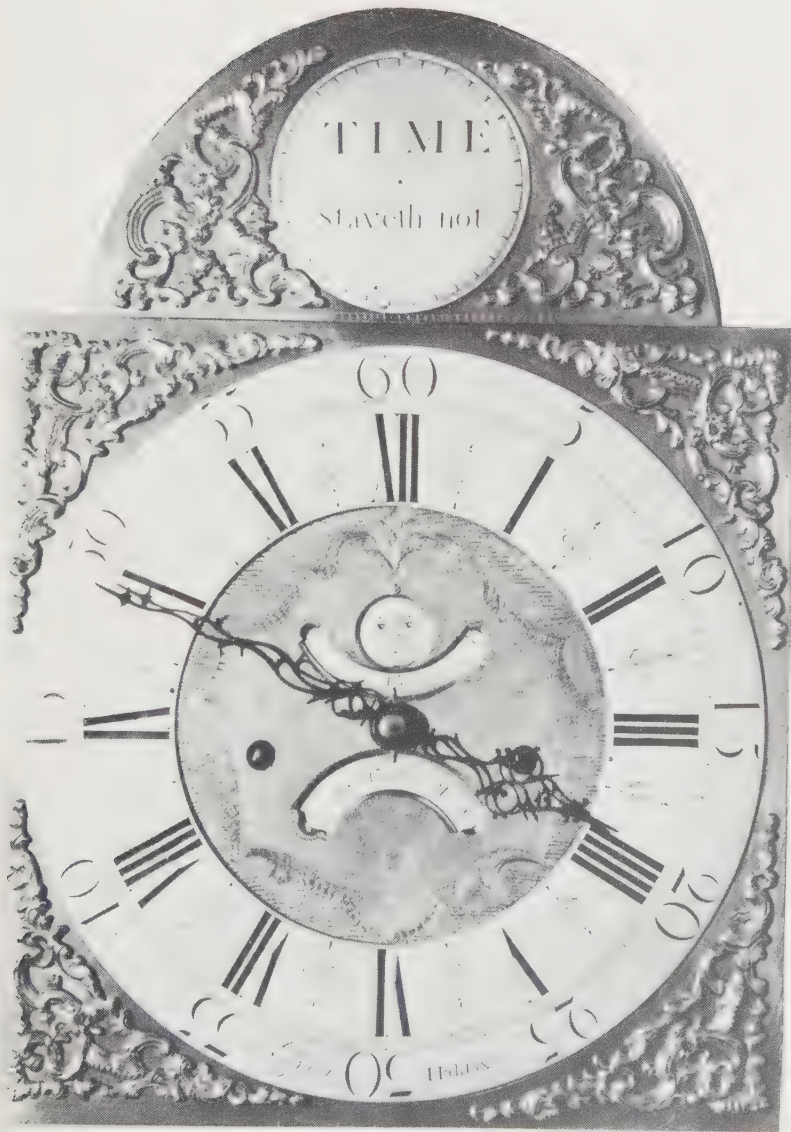



DEVELOPMENT
OF
THE
REGULATOR

Even applying the equation of time to solar time was not accurate enough for checking the best clocks. Clockmakers sometimes had a simple but accurate sundial in their workshops – a tiny hole through which a spot of light from a sunbeam fell on a dark wall. The spot moved relatively quickly across a special mark indicating noon. Makers of the most accurate clocks began to use a ‘clock star’ instead of the sun, however.

A clock star is one that is apparently fixed in the sky so that a point on the earth comes exactly ‘under it’ every day. A sidereal day measured from a clock star is shorter than a solar day measured from the sun and does not have the complication of the equation of time. Its disadvantage for normal use is that it takes no account of daylight and darkness.

John Harrison explained in 1730 how he checked his clocks. He lined up a clock star with the edge of a window-frame in his house and a neighbour’s chimney twenty-five yards away. The star vanished behind these in an instant, ‘and’, said Harrison, ‘I have another person to count the Seconds of ye Clock, beginning a little before ye Star Vanish: So I observe what second is Mention’d when it Vanisheth; and I have a Table Calculated to show how much sooner any such Star is to Vanish every Night, or before ye 24 Hours of ye Pendulum Day is expir’d.’ Such accurate observations showed up irregularities in the going of clocks.

When he invented the practical pendulum clock, Christiaan Huygens had realized that the pendulum was not completely isochronous. To be so, it had to swing in a cycloidal curve, a



Plate 84 One of the most famous of all regulators, made for the first Astronomer Royal, John Flamsteed, by Thomas Tompion in 1691. It runs for about 35 days, and has a long pendulum beating two-thirds of a second. The dial shows minutes and seconds in degrees of arc. The hours, shown in the aperture, indicate up to 36, also in degrees. ($360^\circ = 24$ hours, i.e. one revolution of Earth.)

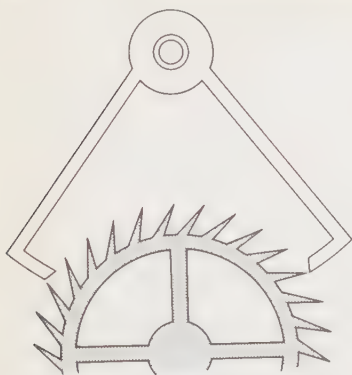

ABOVE

Fig. 30 The dead-beat escapement invented by Graham and usually incorporated in regulators because of its improved accuracy over the orthodox anchor escapement.

OPPOSITE

Plate 85 A sophisticated 8-day movement from a Thomas Tompion clock of c. 1690 with an exceptionally large outside count-wheel. The two hammers sound ting-tang quarters and hours. The front plate has latches instead of pins to attach it to the pillars. The spoon-shaped shutters over the winding squares operate the maintaining power. The cord on the right winds the alarm, with which the clock is also fitted. See also Plate 107.

sharper one than the arc of a circle. He suspended his pendulum rod by two threads between two short and fixed curved plates. As the pendulum swung from one side to the other, the curved plates forced it to swing in a cycloidal curve (see Fig. 2). The idea was not practical and in any case was useless for the long pendulum (see Fig. 3).

A pendulum swinging in an arc begins to lose if the arc of swing increases. The loss in time is called 'circular error'. If, for example, a pendulum is swinging through an arc of five degrees, and the arc increases to ten degrees, it will lose thirty seconds a day.

Clockmakers discovered that the best way out of the dilemma was to ensure that the pendulum arc did not vary. The first step was to cut and finish the clock gearing and escapement as accurately as possible, so that the impulses applied to the pendulum from the clock weight were as constant as possible.

The anchor escapement was accurate enough for ordinary domestic use, but not for clockmakers themselves and for customers intending to carry out astronomical observations. The anchor has a braking effect on the swing of the pendulum, which is easily seen by watching the seconds hand recoil at each tick. This restraint improved timekeeping of an average clock by keeping the arc of the pendulum reasonably constant. But in a very accurately made clock it was a liability.

George Graham therefore modified the anchor escapement in 1715 to eliminate the recoil. The seconds hand did not 'bounce back' slightly after each tick, but remained motionless between ticks, or 'beats' as the clockmaker calls them. It was therefore 'dead beat' and Graham's invention is known as the dead-beat escapement (see Fig. 30).

The escapement was adapted for very accurate longcase clocks and particularly for regulators. It is still favoured for many of today's master clocks in offices and factories.

Huygens also realized that while a clock weight was being wound up, the clock was relieved of its driving power and therefore slowed down or stopped. He devised the endless rope arrangement described in Chapter Two to give maintaining power while winding. The endless rope or chain was only applied to clocks running for about thirty hours which are wound daily by

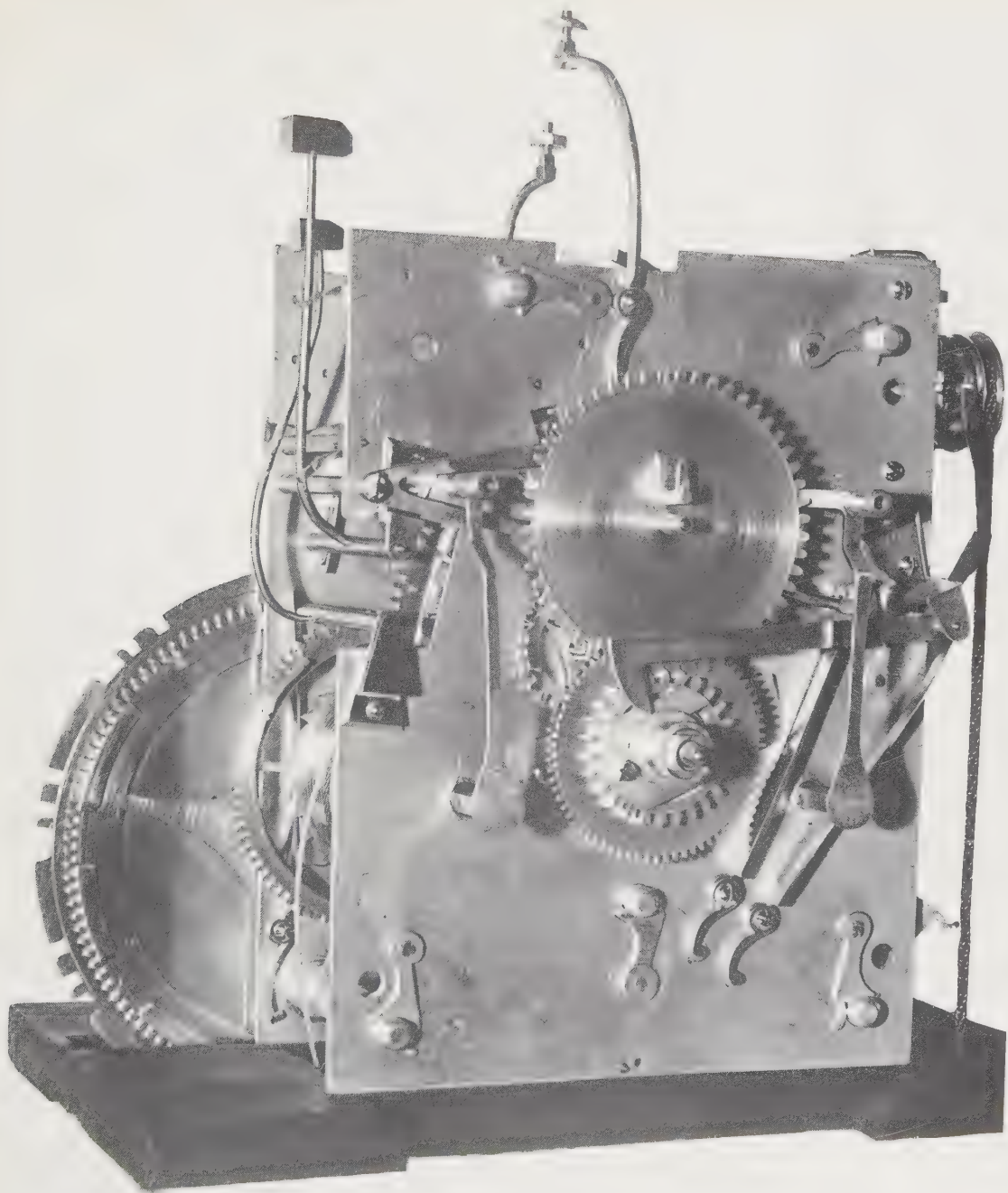

OPPOSITE

Plate 86 A mysterious regulator made by Thomas Tompion. The tapered 5 feet 4 inch case of oak is old, but not original. The date ring has a pin setting, and there is a bolt and shutter maintaining power.

opening the trunk door and hauling on one of the chains or ropes. The loss of half a minute a day by winding would otherwise soon add up to a large loss.

Clocks going eight days, a month, or longer, are wound by a winding key inserted through a hole in the dial. The weight is raised by a gut line being coiled round a barrel. This arrangement provides no maintaining power – no power to keep the clock going during the half-minute or so while it is wound – but half a minute a week was not considered worth compensating for in ordinary domestic clocks. A regulator going for one month is shown in Plate 84.

The loss of half a minute or more a week is serious in an accurate clock, however. In addition there is a possibility of damage to escape-wheel teeth if the sensitive dead-beat escapement is fitted because winding tends to make the escape-wheel turn backwards.

A device known as ‘bolt and shutter’ maintaining power was invented very early on for key-wound longcase clocks. The key holes – for both going and striking trains – in the dial are covered by small shutters immediately behind the dial, which have to be moved to one side before the key can be inserted (see Plates 53, 85, 86, 105, and 107). The act of moving that for the going train causes a spring-loaded lever to press against a tooth of one of the wheels to keep the clock going for two or three minutes while the shutter moves back into position.

In clocks with the early lift-up hoods, the shutters are opened by pressing down a lever projecting from the side of the movement. In clocks with hoods that pull forward, a cord hanging into the trunk has to be pulled down, after opening the trunk door. Bolt and shutter maintaining power went out of use from about 1740.

It was discovered by clockmakers that their clocks went slower when the weather was warm. Two among the more ingenious of them – George Graham and John Harrison – independently discovered the cause and managed to correct the discrepancies which were due to the iron pendulum rod expanding or contracting in length and making it swing slower or faster.

The ordinary pendulum rod in use throughout the life of the longcase clock was a thin, fairly stiff iron wire with a strip of flat clock spring riveted to the top end. This spring suspension is fitted

into a slit in a projection called the pendulum cock on the back of the clock and is stopped from being pulled out by a piece of brass riveted to the extreme end of the spring. At the other end, the pendulum wire rod is threaded. The bob on this end is lenticular – shaped like a discus – with a hole across a diameter for the rod to pass through freely. A nut (usually square) prevents the bob from falling off and also raises or lowers it, on a rectangular section of the pendulum rod, to regulate the clock. It is thus called the ‘rating nut’. The bob was made of lead and covered with polished brass (see Fig. 3) up to about 1740 when uncovered cast iron began to replace brass covered lead for the weights as well as the pendulum bob. The cast iron bob was sometimes decorated with imitation gold leaf known as ‘Dutch gold’.

Over several years Graham made experiments on the expansion of metals and, on accidentally discovering that mercury had a much higher rate of expansion than solids, realized he could make a compensated pendulum.

He constructed his pendulum rod of brass with a fork in the bottom. The fork held a jar of mercury which acted as the pendulum bob. In hot days, the pendulum rod expanded *downwards* and Graham found by experiment that a certain quantity of mercury would compensate for this by expanding *upwards*, with the result that the time of swing of the pendulum did not alter with temperature changes (see Plate 87). This was in 1721.

About the same time John Harrison and his brother James were also experimenting. John wrote, ‘I prepar’d a Convenience on ye outside of ye Wall of my House, where ye Sun at 1 or 2 a Clock makes it very warm, to try ye different quantity the one foot of metal alter’d in proportion to another ...’ He arrived at surprisingly accurate figures and used the information to devise a pendulum with nine wires, all parallel, five being of steel and four of brass. They were attached so that the five steel ones lowered the pendulum bob as they expanded and the four brass ones raised it. The total lengths of steel – about nine feet – and brass – about six feet – gave the same actual expansion, so the bob was neither lowered nor raised during temperature changes. Harrison’s gridiron pendulum was invented about 1726.

John Harrison also discovered by experiment that the air has an effect on the pendulum. In cold weather the air is heavier and



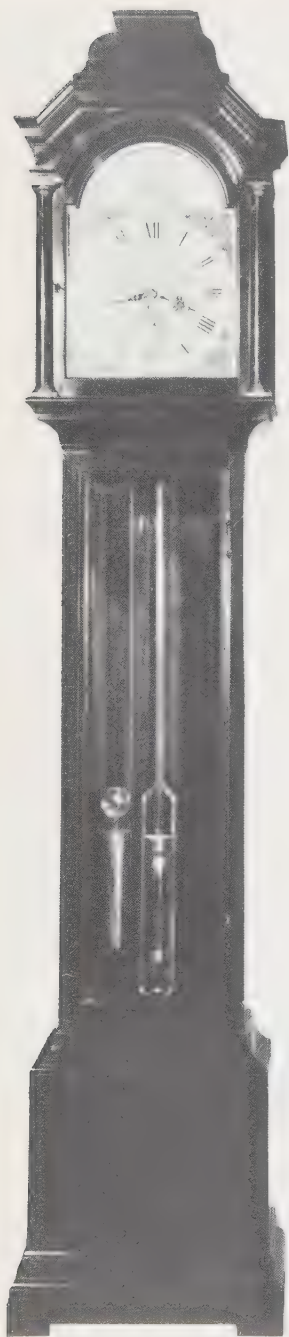

the pendulum does not swing in such a wide arc, which makes it gain slightly if the pendulum remains exactly the same length (because of circular error, although Harrison thought he had compensated for this by using cycloidal cheeks). So he arranged his gridiron pendulum to overcompensate slightly, i.e. to lengthen slightly in cold instead of contracting. This made the pendulum try to go a little faster, and therefore compensated for the small loss caused by the denser air.

Remarkable accuracy was obtained for those times. Quoting again from Harrison's manuscript, which was mainly about making a clock to use on ships for navigation and only came to light in recent years, '... in these 3 last Years [I] have brought a Clock to go nearer ye truth than can well be imagin'd, considering ye vast Number of seconds of Time there is in a Month, in which space of time it does not vary above one second, and that mostly the way I expect.'

The longcase clock referred to, made by James or John Harrison, is now in the Clockmakers Company Museum at the Guildhall, London. The Harrisons used a special escapement of their own design known as the 'grasshopper' because of the way it looked and jumped. It was made of wood like so much of their clock parts – even the toothed wheels – because they started their working lives as carpenters, and because they tried to eliminate oiling which affects the rate of a clock. One of John Harrison's clock movements is shown in Plate 88.

The grasshopper escapement never came into general use and was only employed by the Vulliamy clock making family, many years later, unlike Graham's much simpler dead-beat anchor, which many copied and is still manufactured today. Very exceptional is the regulator with a chronometer or detent escapement, normally visible in front of the dial.

It was clearly evident to Graham that striking mechanisms, calendar work, moon dials, and other complications driven by the timepiece, affected a clock's timekeeping when fine limits were concerned, so he eliminated all unnecessary complications. George Graham was the true originator of the high-quality clock of simple design, the sole criterion for which was accuracy of timekeeping.

This class of clock had achieved a separate identity by mid-

Dead-beat escapement

Seconds hand

Minute hand

Hour hand

Great-wheel

Weight

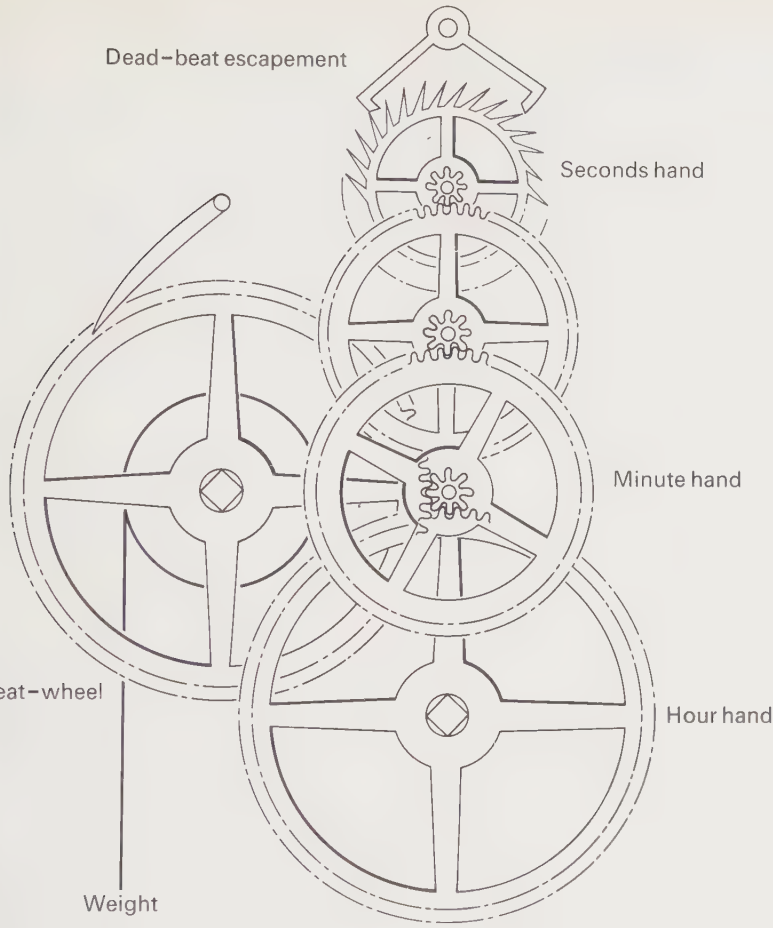

OPPOSITE

Plate 87 The famous regulator made in 1730 by George Graham, London, with dead-beat escapement (a refinement of the anchor escapement), calendar, and compensated mercury pendulum.

LEFT

Fig. 31 The simple train of a regulator, which has no motion work. Harrison maintaining work is incorporated in the great-wheel.

eighteenth century and was being constructed by a number of different makers. The design of the case became even more severe and the square dial with a plain top, following the style of almost the earliest period, became more or less standard after about 1760. It was generally in mahogany or oak. After about 1810 it was the rule to provide the trunk door with a glass panel.

It was discovered that the 12 to 1 gearing called the 'motion work' by which the minute hand drives the hour hand on an orthodox clock dial was also a source of error in a precision clock, so the motion work was discarded and a very distinctive

style of dial adopted. The dial is almost invariably silvered all over with the indications engraved and filled with black wax or enamel. There are three rings of numerals and three hands each sweeping over its separate chapter ring. The largest ring (where the hours are normally indicated) is divided into sixty and a long hand shows minutes on it. A separate small chapter ring below centre with its own hand is for hours and the third one above centre in the orthodox place shows seconds (see Fig. 31 and Plates 89–91).

In construction of the movement, everything was sacrificed for simplicity and skill in execution. Although the escapement is usually a Graham dead-beat, a ‘gravity escapement’ like that in ‘Big Ben’ was used later in the nineteenth century. A clock with a gravity escapement is shown in Plate 21. The temperature-compensated pendulum hangs from a heavy bracket on the back of the clock case instead of from the back of the clock movement, which reduces the risk of movement of its anchorage.

The pendulum is normally either Harrison’s gridiron or Graham’s mercurial. On later clocks, zinc tube compensation is sometimes found, an arrangement similar in principle to Harrison’s, but employing a steel rod or steel tube for expansion downwards and a zinc tube to compensate upwards. Still another compensation found in cheaper regulators is a wooden pendulum rod with a lead bob. Various woods were found suitable – pine, fir, mahogany, and others – of straight grain, dried out and varnished or saturated in paraffin wax. These vary very little in length at different temperatures. The wooden rod is fitted into a hole in a cylindrical bob of lead fastened near the bottom so that the bob expands upwards to compensate for the small amount of expansion of the wooden rod in heat. The pendulum bob of a regulator is usually cylindrical to reduce the risk of twisting affecting its swing.

Maintaining power, essential in a regulator, is generally a modified form of what John Harrison invented originally for spring-driven clocks. Its essential feature is that the barrel turned by the driving weight is not connected directly to its gear-wheel but has to compress a spring in order to drive the wheel. While the clock weight is being wound up, the compressed spring is prevented from expanding backwards by a ratchet, so it pushes

forwards and continues to drive the clock for two or three minutes.

Harrison's maintaining power cannot be recognized from the dial, unlike the earlier bolt and shutter. Looking at the movement, however, two pawls and ratchet-wheels – the clockmaker calls them clicks and click-wheels – on the winding barrel will disclose the kind of maintaining power.

The weight itself, usually of lead encased in brass in the same way as the weights of earlier longcase clocks, carries a large pulley-wheel by which it hangs on its gut line. This doubles the effective power it supplies. It was common in later regulators to employ jewelled bearings in the movements.

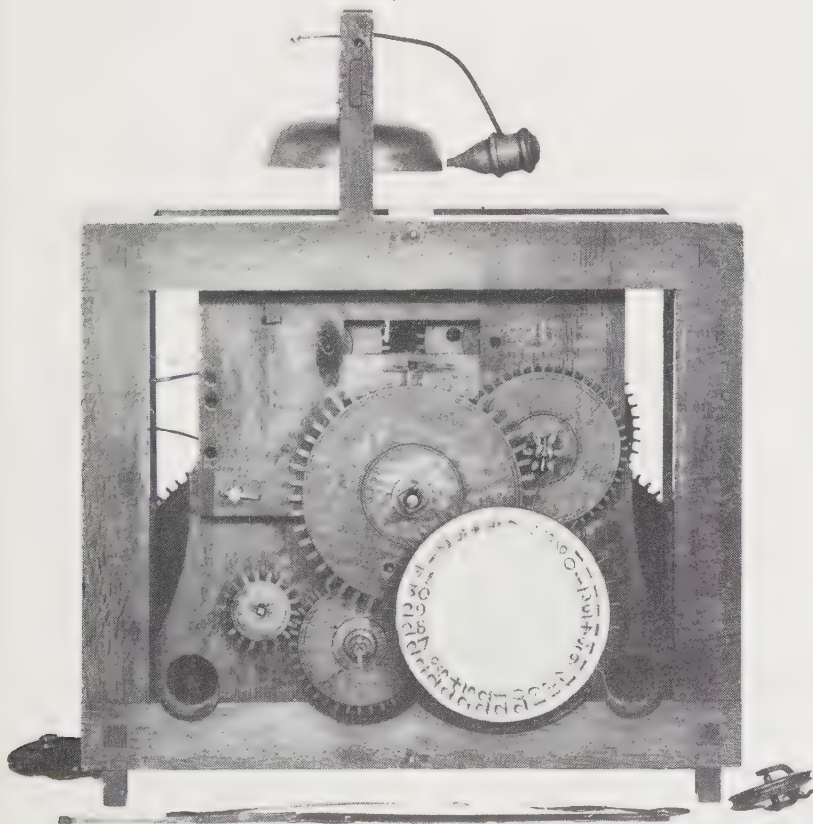

Plate 88 Wooden movements were extremely rare in England, although common in Germany and North America. This was made in oak by John Harrison of Barrow, c. 1717, and is in a clock in Nostell Priory. The plates, frame, wheels, and even the bell hammer head, are wooden. The white dial is a calendar.



Regulators were produced from the eighteenth and throughout the nineteenth century, long after the longcase domestic clock was finished; in fact, some are still made today. They were always well made, mainly by hand, and even the most recent versions are not ordinary factory products. Their plain cases contrast considerably with the more flamboyant later domestic clocks and from the present distance in time are seen to have much greater aesthetic merit.

Regulators were required by clockmakers themselves to adjust new and repaired clocks to time – hence the name. Observatories and other scientific institutions needed them. Some big houses and clubs had them as master timekeepers, so did the embryo factories of the time; the horse-coach and mail-coach services needed them for setting mail-guards' watches, as did Pickfords the carriers, the shipping concerns, and the growing railway companies.

A 'time current' from Greenwich Observatory was sent daily by the 'electric telegraph' of the General Post Offices to many towns and railway stations for checking regulators themselves, but this was not until after 1850. Until then clockmakers had to rely mainly upon the sundial.

Anyone owning a regulator or any other clock with maintaining power, by the way, should first press the winding handle in the opposite direction before winding. This ensures that the maintaining work is properly engaged. It is unwise to turn the seconds hand backwards because, apart from risk of damage, this can affect the rate of the clock by distributing oil in the wrong places.

The teeth of gears in a clock should never be oiled and oil of the right kind in other places has to be very carefully applied. The Harrisons knew this fact when they built their very accurate longcase clock referred to earlier in this chapter. Their method of overcoming the difficulty of oil affecting clock rates was to avoid oiling altogether by using wooden roller bearings.

Even railway-station regulators are to be seen in the shops of antique dealers today and they can be admired for their style and quality. The true regulator is a longcase clock and should not be confused with the Viennese 'regulator' which is an Austrian wall clock with a long pendulum and glass-fronted door in the trunk. Those seen in antique shops are almost invariably small German versions of the true Vienna regulator.

OPPOSITE

Plate 89 A regulator by Ellicott, London, with a 12-inch circular dial, and domed glass, in a 6 feet 6 inch mahogany case of the later eighteenth century.

FAR LEFT

Plate 90 Small mahogany regulator, 5 feet 10 inches high, by Robert Rennington, a London maker who was working between 1780 and 1824. The movement has six pillars to join the plates, a dead-beat escapement with sapphire jewelled pallets, and a Harrison gridiron pendulum. The minute hand is in the centre, with winding through the hand. Seconds are shown above, and there is a 24-hour dial below.

LEFT

Plate 91 A late nineteenth-century style of regulator case. The movement, by John Moore, runs for a month. There is a glass door through which the pendulum and weight can normally be seen, but they have been removed. Note the pendulum arc scale.

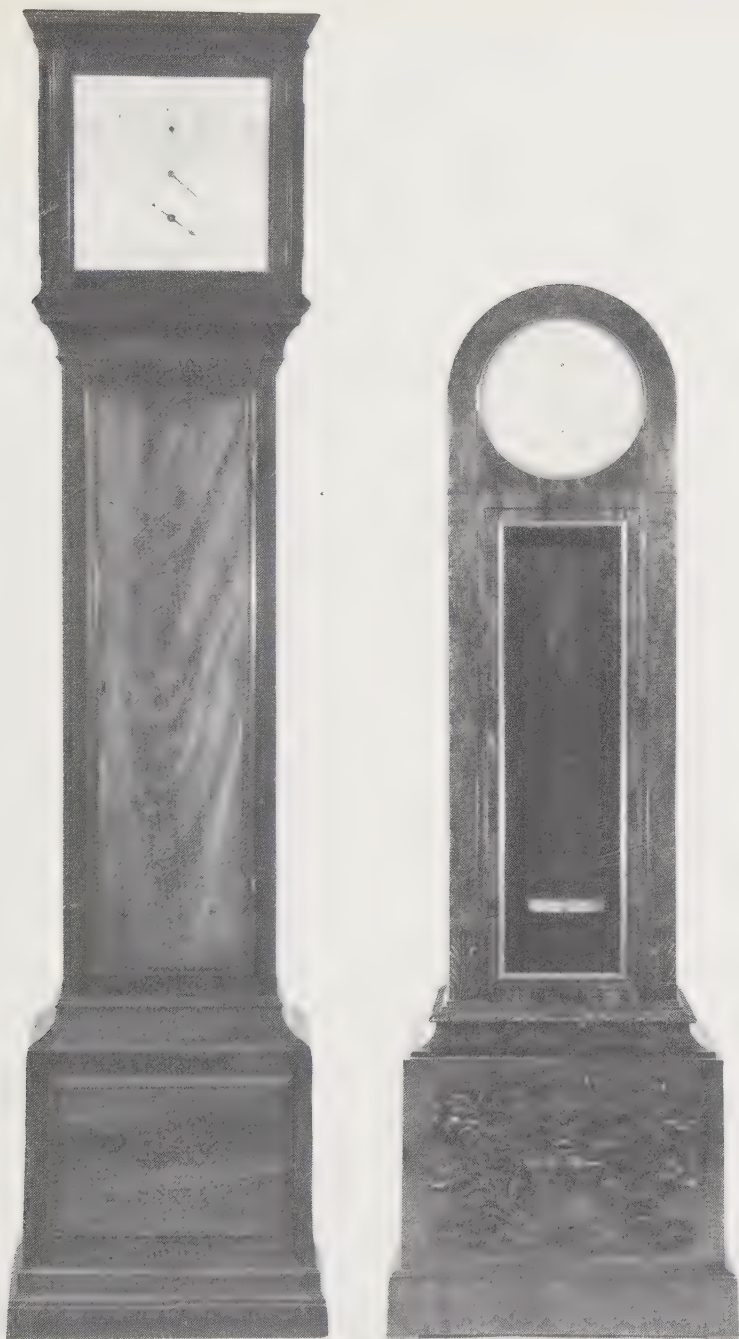



CHAPTER TEN

SPECIAL
CLOCKS
TO COTTAGE
CLOCKS

To those with a mechanical turn of mind the most interesting clocks are the 'specials'. Many of the finest have found their way into museums or important private collections and will rarely, if ever, change hands; others can still be found. In quite recent years, for example, a very important clock with equation work and perhaps the first differential gearing (now common in the back axles of motor-cars) was discovered. This chapter is devoted to some of the more 'off beat' specials. There are probably others waiting to be recognized.

Perhaps the most extraordinary is a perpetual motion clock made by James Cox, an eighteenth-century expert on automata, which was on show in London in 1962. The weights to drive the clock are wound by two large glass vessels holding 150 lb of mercury. The arrangement is actually a Fortin barometer. The upper vessel has a long neck (like the tube of the barometer). It is filled with mercury and up-ended in the lower vessel. Both vessels are suspended, however, and changes in barometric pressure cause relative movement between them, which, by an ingenious rack and pinion action, winds up the clock weight whether air pressure rises or falls (see Plate 92).

The Cox clock is unique so no one is likely to come across a duplicate, but there may have been other attempts to prolong the running of a clock movement as yet unrecognized.

There are some unusual 'watchman's clocks' by Whitehurst still about. John Whitehurst, of Derby, devised the 'tell-tale' clock, forerunner of the clocking-in machine familiar in factories

(see Plate 93). Whitehurst was also a mineralogist and one of the earliest, though unofficial, members of the Lunar Society of Birmingham, a group of intelligentsia which met monthly at the full moon. Other members included Erasmus Darwin (father of the evolutionist), Josiah Wedgwood (porcelain pioneer), John Baskerville (typographer), James Watt (steam engine inventor), and Joseph Priestly (the chemist). Whitehurst was a highly ingenious man and was visited in 1774 by Benjamin Franklin, who helped draft the American Declaration of Independence. The following year Whitehurst moved to London, staying in 4 Bolt Court, Fleet Street, where the famous Dr Samuel Johnson once lived. He was elected a Fellow of the Royal Society a few years later. Apparently he never bothered to apply for patents for his inventions.

Tell-tale clocks are in narrow long cases made of oak, and have rotating dials with fixed pointers to indicate the time. Some have 12-hour and others 24-hour dials. Around the periphery of the dial is a series of metal pegs, positioned radially at every half hour, so that they protrude slightly. Fitted to the clock case is a plunger, which, when pulled out, depresses a peg at the time on the dial. Thus a watchman could record his visits to the spot. The pegs were returned automatically by the clock to their alert positions at an appropriate time. The 8-day movement had a ting-tang chime.

Whitehurst was friendly with James Ferguson, inventor of special tidal dials, and made at least one astronomical clock, although not in a long case.

His tell-tale clocks were in use for more than seventy years after his death in 1788. The business was carried on in Derby again by a nephew also called John and by his son of the same name. In the 1840s they were advertising:

Church, turret, house, and cottage clocks; sun, wind, and miner's dials; weather vanes; spirit levels; barometers; thermometers; philosophical and mathematical instruments; and improved roasting jacks; church bells . . . etc. Original manufacturer of the watchman's clock, for protection from fire and robbery; these clocks are extensively used in London, Manchester, Liverpool, and most of the large towns in the

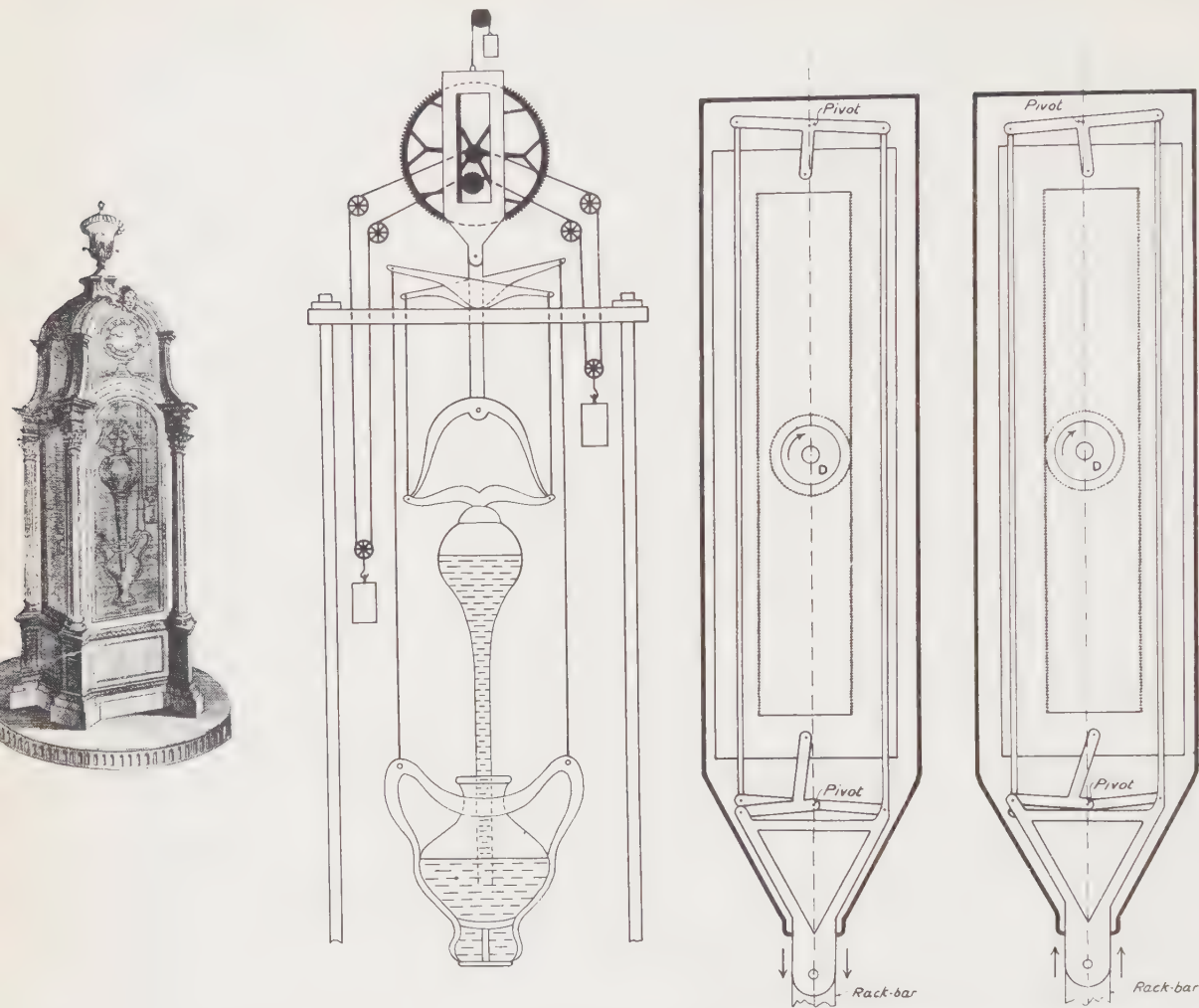

Plate 92 The action of a strange 'perpetual motion' clock by James Cox, in a tall case. It still exists.

United Kingdom, in the establishments of many noblemen, and gentlemen, in mills, manufacturers, wharfs, docks, etc. . . .

They became well known as one of the firms who originally quoted for making the famous Westminster clock, 'Big Ben', after a dispute because Benjamin Vulliamy had been approached direct. E. J. Dent of London, finally made it. Whitehurst of Derby supplied many clock movements to the trade. A tell-tale longcase clock dial is shown in Plate 93.

Many clockmakers made musical clocks, playing usually on bells, the hammers being operated by pins fixed in a rotating barrel at the back or side of the movement. Some played seven tunes – including a hymn for Sunday – which could be selected at will. Much less common were longcase organ clocks. Instead of bells there were organ pipes blown by a small bellows operated by a clock weight. The pipes have valves which are selected and opened by a pin barrel similar to that used for bells. Extremely rare was the harp clock. One in a comparatively ordinary long case is owned by the Prague National Museum. A set of strings, with pegs like those in a piano, is mounted in the back of the clock case. The strings are played by hammers operated by a pinned barrel, so perhaps a more accurate term would be ‘piano clock’, since the strings are not plucked.

Very occasionally a clock will be found with a world time dial. One made by Thos. Lister the Younger of Halifax, who made several complicated longcase clocks in the latter part of the eighteenth century, is shown in Plate 94. It has a planisphere in the arch. Surrounding this is part of a 24-hour ring. The period from 9.30 p.m. to 2.30 a.m. covering hours of darkness is omitted. The XII at the top represents noon and if there were a XII at the bottom it would represent midnight. Inside the fixed 24-hour ring is another ring bearing the engraved names of countries and places around the globe. This second ring is revolved in twenty-four hours, so the time (except for the missing period of darkness) at any place, can be read opposite the place name. As the XII at the top represents noon, hours on the left of it are a.m. and those on the right p.m.

The easiest way of understanding a world time dial is to imagine the XII noon figure to be the sun, and the revolving ring of names below it to be the earth revolving in twenty-four hours. It is noon at the place with the sun overhead.

At the time this clock was made, local times were in use; Greenwich Mean Time all over the country was not established by law until about one hundred years later. Time zones were agreed upon internationally shortly afterwards, in 1884, which made the task of the world time-clock maker much easier, because the minutes became the same in each zone and hours in the appropriate zone could be read from the 24-hour dial and minutes

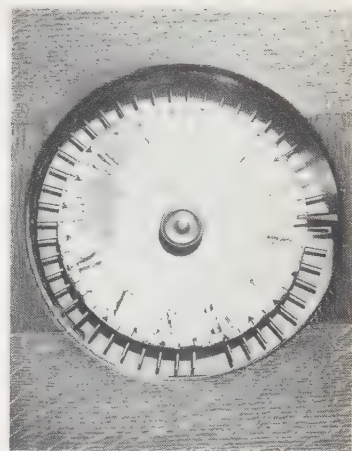

Plate 93 The dial of a watchman's longcase clock by Whitehurst of Derby. When the watchman visited the area, he moved a lever which depressed a peg showing the time of his visit on the dial.

RIGHT

Plate 94 Various indications on a very complicated clock by Thomas Lister of Halifax, Yorkshire. The case is shown without the movement in *Plate 95*. The clock was made about 1780.

OPPOSITE

Plate 95 The fine Chippendale-style case of a very complicated clock by Thomas Lister of Halifax, Yorkshire, made about 1780. It is 9 feet high. The dial is shown in *Plate 94*.

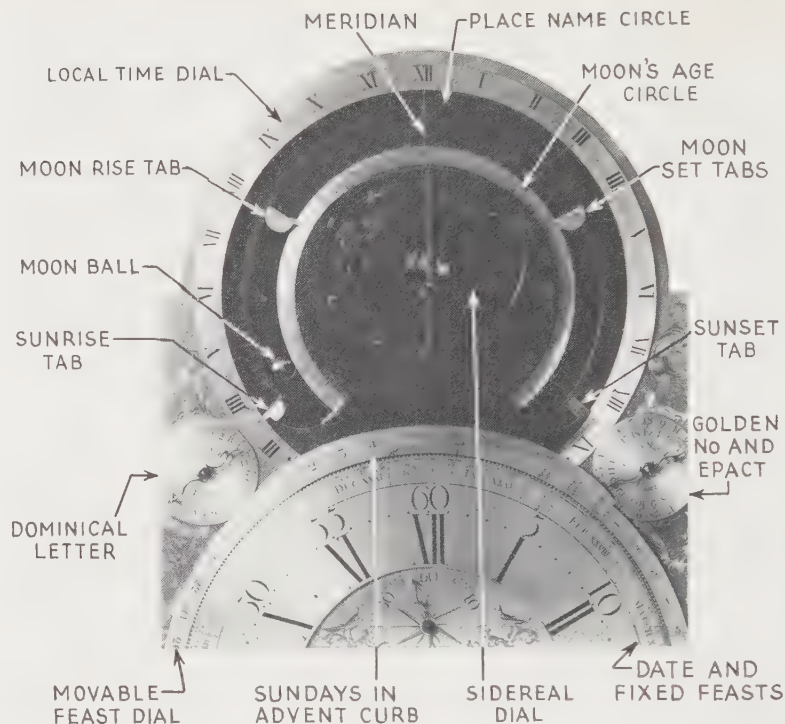

from the ordinary minute hand of the clock. By this time, however, the longcase clock had gone out of fashion.

It is only occasionally that a dial is seen with a true astronomical indication, a changing map of the stars, known as a planisphere. The Lister clock has one of these as already mentioned. There is a large oval hole in the dial, usually in the lower part, and behind this an engraved star map is revolved. The part displayed through the oval aperture gives the position of stars visible in the night sky at that particular time of the year. Such a clock has naturally to be made for a particular latitude, in this case that of Halifax. Those who have come across the adjustable star map published by Phillips will appreciate the type of dial involved. The signs of the zodiac are usually included. The zodiac is a sort of belt in the heavens to which all the planets are confined and it is divided into twelve signs of thirty degrees each.

Thomas Lister designed for his clock an exceptionally accurate

indication of the times the moon rises and sets. This was particularly useful information at the time but was not often incorporated in clocks because the times only repeat themselves every 18.6 years which made the mechanism difficult to devise. He also made the lunation period much more accurate than the usual twenty-nine and a half days.

The moon is shown as a half black and white ball which makes a tour round the arch of the dial, and showing its correct phase. The clock shows, too, in the arch of the dial, a planisphere of the heavens for the latitude of Halifax.

Calendar indications are particularly complex. The 365-day calendar ring is around the dial and the hand shows fixed and movable feasts. Movable feasts are engraved on a separate ring which is set by hand each year to the date of Easter which results in other feasts being correctly indicated.

The Dominical Letter is shown on a separate dial. The use of this is to find out what day of the week a particular date will fall. In older prayer books there is a special table for use with this letter.

The Golden Number is indicated also. This was first calculated by the Greek astronomer, Meton, who discovered that new and full moons returned on the same days after nineteen years. The number gives the year position in the cycle. It is calculated by adding 1 to the current year and dividing by 19, the remainder being the Golden Number, thus $1980 + 1 \div 19$ leaves 4, the Golden Number or fourth year of the nineteen-year cycle. Still another indication on the clock is the Epact, i.e. the age of the moon on 1 January. This and the previous indication are used to calculate the date of Easter and thus to set the movable feasts calendar.

Times of sunrise and sunset are another indication of Lister's remarkable clock. In addition to all this complication, the 8-day movement has a six-bell chime; it is in a fine Chippendale style case, shown in Plate 95.

A different kind of astronomical and musical clock is shown in Plate 96. It is in a mahogany case and is by Joseph Winterbourne, an at present unrecorded maker. On the left in the arch is a compass dial. This gives the bearing of the world city in the sector-shaped dial below at which the time is noon. The sector itself gives world time. In the top left dial corner is a tune selector for the selection of six on eight bells. At bottom left is a day and



OPPOSITE LEFT

Plate 96 Complicated astronomical and musical clock by Winterbourne (signed between the hours of the double XII dial) which is in a 7 feet 1 inch Yorkshire case of around the 1830–40 period. The movement has eight pillars and divided plates. The musical barrel plays six tunes on eight bells with sixteen hammers. The mahogany case is inlaid with boxwood strips.

OPPOSITE RIGHT

Plate 97 Unusual longcase cottage clock made to fit a corner. The case also serves as a cupboard. The weights descend behind a false back to the cupboard.

night dial. The dial in the centre of the arch shows seconds and that at top right is strike/silent. The sector below it shows the week of the year. In the top right dial corner days of the week are shown and at the bottom, minutes. The hour chapter ring of the main dial encloses a lunar calendar ring with a bar extending across a central rotating plate from which can be read the month, date, and sign of the zodiac where the bar crosses. A star map (planisphere) is also engraved on the plate. The hour hand carries a rotating moon ball. All winding is carried out from the back.

Occasionally a clock showed sidereal time (see page 138) as well as mean time. It had two pairs of hands, one showing mean solar and the other sidereal time. There is a magnificent example in the Royal Naval College, Greenwich, made by Daniel Quare in 1710. It has two overlapping dials and two movements with two pendulums. A similar result can be obtained by gearing which makes the sidereal hands gain a day over the mean time hands during a year. Quare's clock also has equation work.

The most unusual of later longcase clocks were made by Alexander Bain in the 1840s. They were among the first electric clocks. The pendulum is an electro-magnet which drives the clock by means of the pallets and escape-wheel, reversing the usual system. The pendulum operates a sliding switch. Current to drive the clock was generated by an earth battery, a quantity of coke and several zinc plates buried in the ground a few feet apart and kept moist and connected by wire to the clock.

We have drifted a long way from the commonplace 'cottage clocks', described in Chapter Eight, which became the bread-and-butter production of thousands of clockmakers all over the United Kingdom after the middle of the eighteenth century. An unusual cottage clock is shown in Plate 97 and an orthodox white dial clock of about the same time in Plate 98.

There were so many specialists in the huge clock trade – in the eighteenth century it employed 70,000 in a total population of only ten million – that the local clockmaker could buy not only his plates, wheels, bells, and other parts in Birmingham, Liverpool, Clerkenwell (London), and elsewhere, but complete movements engraved with his name, if he wished. Consequently many identical movements and clocks are to be found bearing the names of different clockmakers.



OPPOSITE

Plate 98 Delicate fretwork is used with swans-neck cresting for this mahogany clock of about 1790 by William Elliott of Whitby, Yorkshire. The dial is painted, and the age of the moon is shown around the moon dial. Note the feet of the clock. The height is 7 feet 2 inches.

Many thousands of these grandfather clocks are to be found in houses, 'pubs', and hotels today. They have in general been underrated by antiquarians because they are of a transitional period between the hand and machine made, but they are usually much treasured by their owners, often having been in one family for a century or so, and are certainly of interest to students of industrialization. For years they changed hands for a few pounds. The price has crept up with prices of all antique clocks into three figures, but is usually below that of clocks with brass dials. Price alone, however, is no reason for treasuring a thing of the past, especially a clock that has given faithful and accurate service for anything up to three hundred years.

The changes known by antiquarians as 'degenerate', were made inevitable by the progress of industrialization and started almost from the beginning. For example, the first corner decorations, or spandrels, were cast in brass from originals probably carved in wood, and the castings themselves, which would have had a granular surface, were filed up and then burnished to give them a smooth polished surface. Then they were gilded by the old mercurial-gilding process and finally burnished again, because such gilding leaves a matt surface.

This brief description omits all details of the lengthy and skilful hand finishing needed to produce a single spandrel, which, after all, was only an ornament on the dial. Before the seventeenth century was out, the tedious filing and polishing of the castings was being omitted, and gilding applied to the brass as it came from the mould. Almost all clocks of the eighteenth century have spandrels with rough cast surfaces. Only on occasional 'specials' are smooth surfaces found.

There was even further degeneration. Spandrels followed an almost regular sequence of fashion and some brass founders working for country makers, wishing to keep abreast of the newest trend, would use an actual brass casting of a new design as a pattern for duplication. As such a pattern would itself be defective, the final result was even rougher.

The metal capitals – the metal terminations of columns each side of the hood – are another example. Some of the earliest were built up of as many as forty separate pieces. Soon they became simple, one-piece castings or were omitted altogether.

Many of the late clocks were made of wood and painted a golden colour.

Degradation of construction did not occur to anything like the same extent with cases, indeed many late ones are magnificent examples of the cabinet-maker's art. But elaborate inlays and other decorations became too expensive or too difficult because the skilled craftsmen were not available. The degeneration this time was in design, particularly in the northern counties where there was apparently competition between some clockmakers in providing clocks in taller, wider, and more ill-proportioned cases, to the newly rich rising on the tide of the industrial revolution. The big, gaudy clock was then the same symbol of success that the big, ugly car was 150 years later in the tide of American industrialism. Both now have a fascination for many people.

Hands of clocks endured longer than spandrels as an example of hand finishing, almost to the end, in fact. It was apparently the custom of some clockmakers to start their apprentices on cutting out and filing hands after the outline had been marked out by someone else. The hands were not merely cut in the flat, but carved and shaped to some extent on the surfaces. A modern hand – occasionally used to replace a lost original one – does not have such surface cuts and can soon be recognized. The same remarks are true of both steel and brass hands. Late ones – particularly those in brass – were stamped out and are quite easy to identify by the marks of the cutter along the edges – a series of fine ridges and grooves from front to back.

The spandrel disappeared when painted dials came into fashion made possible by the rolling mills established in Wolverhampton and Pontypool. These painted dials are occasionally wrongly described as enamelled, although the colours were usually baked to fix them. The word 'enamel' itself has changed in meaning. The original and true enamel was a soft, usually opaque, white glass coating fused by heat on to metal. Bracket clocks and particularly watches, had enamelled dials during the seventeenth century, but the difficulties of making large ones for longcase clocks were usually too great, but see Plate 58. A few early Vienna regulators have them and some French clocks have a dial made up of a number of enamelled panels (see Plate 125). To confuse even more, the first imitation enamels were called 'Japan' to suggest lacquer or



OPPOSITE

Plate 99 Vulliamy, London, was the maker of this clock in a mahogany case with silvered dial. The style of the case is a reversion to the earliest classical architectural form, although the date is late eighteenth or early nineteenth century. The dial is silvered with matching hands. The movement has rack striking and a wooden pendulum rod.

japanning. Others have appeared since and today there are many so-called 'enamels' on the market. These are useless for restoring true enamelled dials, for which indeed it is almost impossible to find restorers. The painted dials of longcase clocks were truly painted, with numerals, chapter ring, coloured decorations, and any additional indications, on a white ground, except rarely as in *Plate 58*.

At this time in the history of the longcase clock, the clockmaker ordered movements from Thwaites and Reed of Clerkenwell, London; Handley and Moore of London; George Ainsworth of Warrington; Walker and Finnemore of Birmingham; Whitehurst of Derby or another embryo factory. One of the last factories making longcase clocks was John Smith and Sons, of Clerkenwell, London, still in existence in the 1920s (see *Plate 100*).

Dial making became much more specialized with the advent of the painted dial about 1770. When two different trades were involved the problem of mating the dial to the clock arose. Normally the dial had four 'feet', which projected into four holes in the front plate and were held there by tapered pins. Clockmakers or dialmakers introduced a 'false plate' of iron (many have the dialmaker's name on them), which was interposed between the clock movement and the dial. The false plate was drilled to receive the pillars holding the dial and was fitted with three or four pillars to suit the clock's front plate (see *Plate 127*). Dial feet often have wire through and wound round them (instead of the tapered pins used by the clockmaker) to fasten them to their false plates, which were supplied by the dialmaker.

The false plate seems to have been introduced with the painted dial. Although painted dials were cheaper to make than brass ones and are decried by many who have studied the history of clocks, it must not be forgotten that they were immensely popular at the time, and have a legitimate place in the development of the clock dial, for they are finer in conception than many dials of modern clocks. At all times the hand craftsman has gradually been priced out of business by other, quicker and cheaper methods, often producing inferior, but still acceptable work.

The longcase clock enjoyed its long run of popularity because it was very accurate, extremely reliable, and reasonable in cost. One big advantage was that it was not portable and had to be set up and fastened to a wall. That encouraged its development as an

article of furniture as well as a timekeeper but did not long delay its end when the portable spring-driven timekeeper, which had been developing alongside it, was adapted to factory production and became cheap enough to put local clockmakers out of business. In any case, the clockmaker had been taking into stock more and more outside products – although he usually had his own name engraved or painted on the dial and at times engraved on the movement also – and was becoming merely a retailer and repairer, as he is today.

The demise of the longcase clock as a general product was around 1880. Naturally, their making did not end everywhere simultaneously. In London, which led in fashion, most clockmakers had finished with them in mid-eighteenth century, before their greatest popularity in other parts of the country. A few makers lingered on through the nineteenth century constructing clocks to special order – such firms as Vulliamy (see Plate 99); Barraud; Barraud and Lund; Dwerrhouse, Carter & Co. of London; Reid and Auld of Edinburgh; Whitehurst & Son of Derby – but most of their output was regulators. Even these used to buy their ‘bread and butter’ clocks from one of the embryo factories with their names already engraved on the movement and painted or engraved on the dial. Thwaites and Reed’s records list the names of a number of famous makers for whom they provided this service, including B. L. Vulliamy.

In Birmingham from about 1770, where many dialmakers set up in business as well as a few embryo factories making clock movements for the trade, the famous Matthew Boulton, ‘father’ of the Birmingham metal-working trades, started a clock factory about 1772 or 1773. It seems that he produced one or more batches of 30-hour, longcase, posted frame, one-hand clock movements, probably supplied not only as separate movements but with the name of the ‘clockmaker’ and town to whom he supplied painted or engraved on them. Since he would have gone to a dialmaker, it is reasonable to suppose that false plates were used. It could be that the false plate was invented by the dialmaker and quickly taken up by the embryo clockmaking factory, in order to expand its business.

It is obvious today, but not commonly recognized at the time, that anyone venturing into batch production of any article had to



Plate 100 A hybrid longcase clock from an early twentieth-century catalogue. The case is ornate, but the movement and dial are that of a regulator. Similar cases were used later for clocks with orthodox dials and tubular chimes which could be viewed through the glass door. The makers were John Smith and Sons, Clerkenwell.

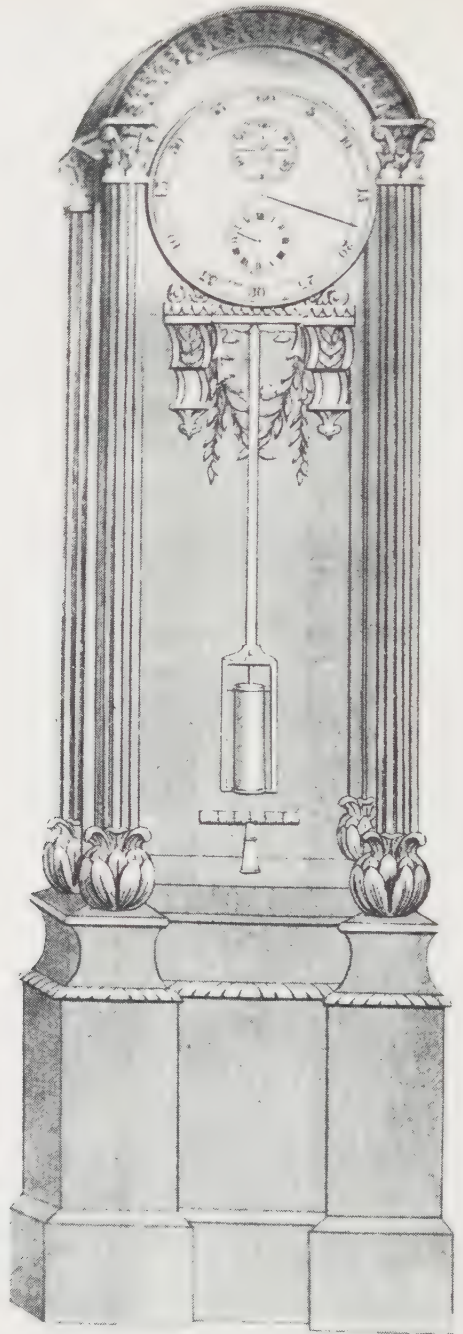

have customers lined up to buy the factory's production. With the growth of clockmakers who had converted themselves for economic reasons into retailers, that market existed. The clockmaker-retailer was already employing new sales techniques. For example, the Deacons, in Leicestershire, a famous provincial clockmaking family, and probably others in other parts of the country, had started 'clock clubs' in the late eighteenth century, the members of which paid in small sums of money at regular intervals in order to buy clocks at discounted prices. It has been suggested that one of the attractions was to have their own names painted on the dials, which means that the club customer at the time may today be regarded as the maker! Even today, however, there are one or two real clockmakers in the UK, still making traditional longcase clocks, even with such elaborations as Ferguson's tidal dial, mainly by hand-craft methods. Several manufacturers also currently produce longcase clocks of good performance but they are, of course, almost entirely machine made.

To return to the late painted dial period, as the cases were so often well made it was not at all uncommon for dealers in recent times to remove the painted dial and fit a brass one, because anyone looking for a clock who has read an earlier book on the subject soon learned that the painted dial was despised. A dial that has been mated to a movement to which it does not belong can often be detected by the expert, although it may not be apparent to the layman; antique furniture dealers can also make mistakes. One thing to look for is whether the winding holes in the dial are concentric with the squared ends of the winding arbors of the movement which accept the winding key. Some are so bad that new winding holes have been drilled through the chapter rings – even through the numerals themselves – and the old holes blanked off, not infrequently with different coloured brass. A wrong dial is not always a good fit. Occasionally a square dial is encountered with a semicircular part added to the top to make it fit a break-arch case. This fake is easily distinguishable from the original break arch which was made in two pieces, as compared with most, which are one-piece. Another trick is to replace the boss in the centre of a break arch by another bearing a more famous maker's name.

Wrong hands are common, but not necessarily faked, because the originals may have been broken. Longcase clocks last so long that normal replacements, even if they are not correct, have to be accepted. What is not acceptable is a moon or calendar dial or hand (with the mechanism that should operate it missing) that has been soldered into place by a botcher wanting a quick financial return on the clock he has doctored. It is not so rare as might be thought. Whole trains of gears may be missing. What is stranger is the addition of a chiming train to a clock that was not intended to have one. Some such trains were added in the late nineteenth century.

If a case had at some time been badly damaged, leaving its movement, dial, and hands in excellent condition, the case may have been exchanged for one with a worn out or inferior movement. Provided they are of the same period, no great harm is done because the movement and original case would have come from different craftsmen and have had to be mated in the first place. As surviving longcase clocks have had up to three hundred years of constant use, it would be extremely unrealistic to expect that every one had survived unaltered. During constant winding and turning of hands, moving it, storing it, selling it, passing it on to others, using it, panels might have been damaged, the key lost or hands broken and replaced, new parts supplied to the movements, spandrels, and other simply fixed ornaments lost and replaced, weights replaced and so on.

In addition, in common with other articles in current use, the longcase clock was not necessarily regarded at the time as having so much merit that it could not be cut off at the base to fit a room with a lower ceiling, mounted in a 'modern' case, or even have the brass dial painted and the case fitted with carved decoration, feet and so on. Such 'improvements' can usually be spotted quickly by the man who has studied clocks, and it is current practice to have them removed and the clock restored, if a good specimen, to its original condition. All of this can be considered legitimate, but this is not so of the practice during the present century of some dealers who, to satisfy the demand for clocks with brass dials, replace the painted ones in fine cases by brass ones. Two unusual clocks are shown in Plates 101 and 102.

FAR LEFT

Plate 101 Unusually shaped clock of the late eighteenth century by Josiah Emery, London, which is in mahogany, and only 5 feet 9 inches tall, with a 10-inch dial and matching hands.

LEFT

Plate 102 A longcase clock built to regular standards except for the concentric hands with centre-seconds hand on the one-piece silvered dial, and the omission of jewelled escapement pallets. It has a mahogany case, and was made by James Patterson of Banff, in the later eighteenth century.

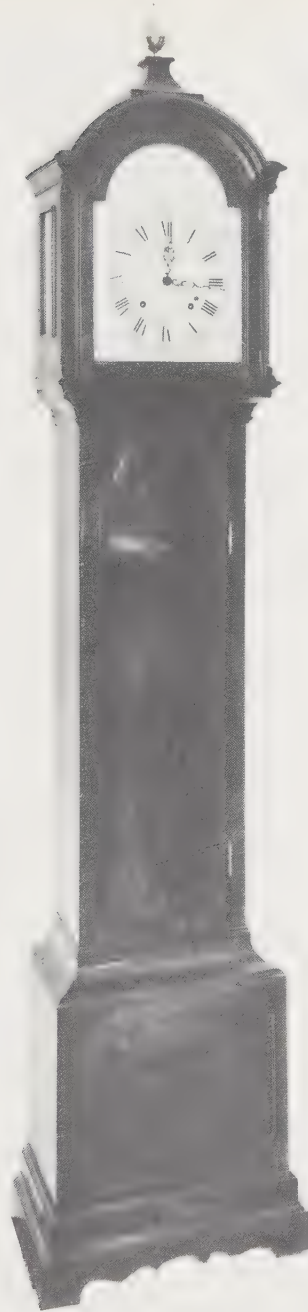



CHAPTER ELEVEN

THE
FAMOUS
MAKERS

The best-known longcase clockmakers were the earliest because they directed the course of development and their work was less stylized than that of later makers. They were few in number and nearly all worked in London, although most were born elsewhere. They were followed by hundreds of others – some whose craftsmanship was quite equal to that of the London men – in and around main towns such as Edinburgh, Leeds, Manchester, Liverpool, Birmingham, Bristol, and so on. The hundreds grew into many thousands at work in the second half of the eighteenth century.

It is obviously impossible even to try to list makers in a book of this sort and there is no point in doing so, as a reference book by the horological historian, G. H. Baillie, *Watchmakers & Clockmakers of the World* gives some 36,000 names, brief details, and dates. It is still in print and can be bought, or consulted in any public library. As this edition is going to press, a second volume of *Watchmakers & Clockmakers of the World* by Brian Loomes, giving over 30,000 more names, is announced for publication in 1976.

Early in the seventeenth century, London clockmakers were experiencing competition from French, German, and Dutch craftsmen who had come to live in the city. In 1622, they tried to obtain a charter from the King to enable them to control the craft, but they were unsuccessful. A number of clockmakers belonged to the Worshipful Company of Blacksmiths, which controlled the then allied craft, and a petition for controlling 'Clockmakers Strangers' was presented by this Company to the King, also without effect, so the clockmakers asked if they could all join the

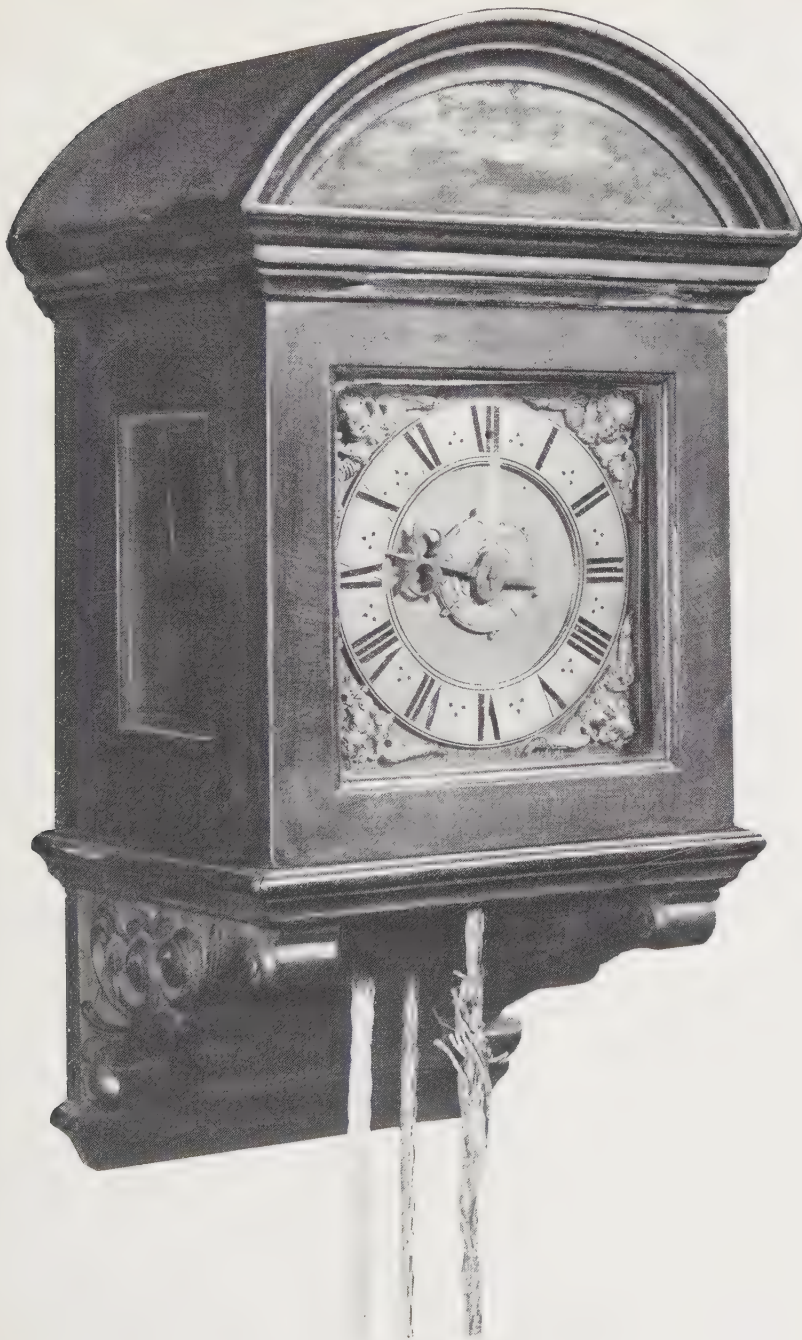

Plate 103 Some lantern clocks were given square dials and mounted on wooden wall brackets with hoods. One school of thought is that the enclosure of the weights led to the development of the longcase clock. Joseph Knibb, London, made this one about 1690 after the long case had become established.

OPPOSITE

Plate 104 A small longcase clock of c. 1685 by John Knibb in a fine walnut case. The date aperture is under the XII chapter. Note the bun feet.

Blacksmiths. This the Blacksmiths 'did dislike', so the clock-makers of London went to the Court of Aldermen who reported with favour on their petition and at last in 1631, the Worshipful Company of Clockmakers was formed, which could not only control working conditions in the trade, but prevent any foreigner from working except with a member of the Company, enter any premises and destroy faulty work, and also prevent importation of clocks, watches, and sundials without its approval. The Charter included mathematical instrument makers.

Among London's early makers was the Fromanteel family, the history of which has been researched by the Yorkshire genealogist, Brian Loomes, to whom I am indebted for the following facts. The chief member of the family, Ahasuerus (1607–93) was a third generation Englishman although descended from Huguenot grandparents, and was working as a clockmaker in East Smithfield at least as early as 1630. His son John, born in 1638, served for a time with Salomon Coster and introduced 'the pendule' from Holland. Another son, Ahasuerus (II) was born in 1640. He was made Free of the Clockmakers' Company in 1663 and emigrated to Holland where he married and ran the Dutch branch of the business until he died in 1703. There was a third son, Abraham, born about 1646, who, after starting training in London as a clockmaker, went before completing it to Newcastle upon Tyne. He seems to have worked mainly in Newcastle, where he died in 1731, although he did return to London in 1680. A fourth son, Daniel, born about 1651, began an apprenticeship, but probably died young before starting work as clockmaker. There were two daughters, Mary, who married clockmaker Thomas Loomes, who lived and worked in Lothbury, and Elizabeth, who married another clockmaker, Joshua Winnock. Son John had a son he named Ahasuerus (III) who was trained in the trade but probably died not long after his father. After 1679 Ahasuerus Fromanteel became celebrated in his own day, because the Diarist, Evelyn, referred in 1660 to 'the work of our famous Fromanteel'. Ahasuerus Fromanteel gave his address in his famous advertisement (Chapter Three) as in Mosses Alley and also the address of his son-in-law, Thomas Loomes, at the sign of 'The Mermaid' in Lothbury.

A master clockmaker usually worked in his own house with his apprentices and traded from there. As was the custom of the time,

his trade was symbolized by a sign instead of his name over the door as today, because there were many who could not read or write. Most clockmakers incorporated a dial. Well-known signs of earlier times included the Dial and Star, the Dial and Crown, the Dial and Two Crowns, the Dial and Three Crowns, and the Dial and Unicorn. Occasionally the sign was an earlier one not related to the trade, as with 'The Mermaid'. The business sign persists today in inn signs, barbers' poles, and pawnbrokers' three balls.

Quick to follow the Fromanteels' lead with longcase clocks was Edward East, a fine craftsman who worked at 'The Musical Clock' in Fleet Street, and was holder of the office of Royal Watchmaker to King Charles I, and lived so long – until the age of ninety-four – that he was once thought to be father and son.

Another early clockmaking family was the Knibbs, the most prominent of whom was Joseph, born in 1640. He and his younger brother, John, moved to Oxford when in their twenties, where Joseph was a clockmaker apparently working for Trinity College. He made clocks for the College and the Oxford smiths demanded that he 'suddenly shut his windows' because he was not a Freeman of the city, so, it seems, the College officially appointed him gardener so that he was on the payroll and therefore untouchable. Later he was admitted to the Freedom on a fine of £6 13s. 4d. and a leather bucket, but moved to London in 1670 and became Free of the Clockmakers Company, and may have invented the anchor escapement. A hanging wall clock (predecessor of the longcase) by Joseph Knibb is shown in Plate 103, and a longcase clock by John Knibb in Plate 104.

Joseph Knibb set up business at the sign of 'The Dyal' in Suffolk Street (corner of Fleet Street) where he was one of the earliest of longcase clockmakers and, being a traditionalist, retained the narrow cases, narrow chapter rings, and spade-like hour hands after other makers had followed new trends. Joseph made several night clocks after those of Edward East and was also inventor of the system of Roman striking which conserved power in clocks going for one month between windings. His Roman striking clocks, by the way, always have a IV instead of IIII. He retired in 1697 and went to live in Hanslope in Buckinghamshire, where he still made some clocks. His merits were recognized by his being appointed clockmaker to King Charles II, and afterwards to King James II. His brother John remained in Oxford.



BELOW

Plate 105 An early dial on a timepiece by William Clement, London, with simple cherub spandrels (but not the earliest, which had just face and small wings), narrow chapter ring, matted zone, early hands, and a calendar in the seconds ring.

OPPOSITE

Plate 106 A Thomas Tompion clock with carved wooden cresting on the hood of the burr walnut case. It was made about 1680, runs for a month, and is 7 feet 1 inch high. An equation of time table is pasted inside the door.

Samuel Knibb was an older cousin of the Knibb brothers who worked at Newport Pagnell and later in London where he gained the Freedom of the Worshipful Company of Clockmakers in 1663. He worked closely with Fromanteel.

One apprentice of Edward East was Henry Jones, who also gained his Freedom in 1663 and was Master of the Clockmakers Company in 1691. He made some fine longcase clocks in his workshop near the Inner Temple Gate, and may have originated the barometer which Daniel Quare later developed. He died in 1695 at the age of sixty-three and was buried at St Dunstan's in the West, Fleet Street.

William Clement, who may have been the originator of the anchor escapement, was also an eminent clockmaker (see Plate 105). Little is known of his life. He was admitted to the Clockmakers Company in 1677 and became its Master in 1694.



The earliest anchor escapement known is in a tower-clock movement by him on exhibition at the Science Museum in London.

Another important technical invention was striking that could not become out of phase with the time shown on the dial. A clockmaker named Edward Barlow Booth was responsible for it. His original name was Edward Booth and he was born in Warrington in 1636. His family intended him to enter the church, but after ordination in Lisbon, he took the name of Barlow from his godfather (who had been persecuted for his religion) and thereafter devoted his life to clocks. His rack striking, invented c. 1676, is universally used today. He had a tussle with Daniel Quare, the Quaker, over the priority of a patent for a watch which would repeat the hours and quarters. It must have been a tough one between two clockmakers of opposing religions when religion coloured every thought and act, but Quare won. Barlow collaborated with Thos. Tompion in a watch invention. He died in 1716.

Even people not interested in clocks have often heard of the name of Thomas Tompion, who has, perhaps, received more than his fair share of publicity in recent years. Nevertheless, he was regarded in his day as a famous maker and certainly led the way in design when he became established in London. He was born in Ickwell Green, near Northill in Bedfordshire, in 1639, where his father was a blacksmith. Nothing is known of his apprenticeship as a clockmaker, but it was reported while he was working in London that he 'had a strange working head, and was well seen in mathematiks' (see Plates 106–109).

He was not apprenticed as a blacksmith, as far as the records show, although a report written during his lifetime says he was originally a blacksmith and repaired a clock so successfully that he decided to make one and from this beginning became a clockmaker. It has been asserted that he was apprenticed in St Brides, in London, but he had a house and was paying rates there in 1670, so could not have been an apprentice then. In any case, he would have been twenty-five and it was usual for a boy to be indentured from the age of fourteen to twenty-one years.

It is very interesting to note that Edward East, who had been made one of the Assistants to the Court of the Worshipful Company of Clockmakers when it was formed and was already famous, came from Southill, the neighbouring village to



OPPOSITE

Plate 107 Dial of a clock by Thomas Tompion c. 1690 with all the minutes numbered, early spandrels (like the Clement clock in Plate 105) and 'later' hands than the Clement clock. Note the engraving round the dial plate, another early feature. The clock has an alarm, set by turning the centre disc to show the alarm time against the tail of the hour hand. The movement has maintaining power, and also indicates the day, sign of the Zodiac, day of the month, and month. Note the marker's name along the bottom in the early style. The movement is shown in Plate 85.

Tompion's village, Northill, and his father was also a blacksmith. East married a girl from Northill. It is not unlikely, then, that young Thomas Tompion was influenced in his career by the success of the young man from the next village and may have received encouragement from him. Later on, East advised both Tompion and Knibb at times and was regarded perhaps as 'a grand old man of clockmaking'.

If Tompion did go to London in his earlier days, he was back in Northill during the Great Plague, because his father was dying. In the following year, 1666, the Great Fire of London occurred, completely devastating much of old London. Many valuable wooden-cased clocks must also have been destroyed at this time. In 1671 Tompion was made a 'brother' of the Clockmakers Company (which meant he was already a clockmaker), but did not gain his Freedom until 1674. This was about the time that he occupied a house in Water Lane, which ran down to the River Thames from Fleet Street. A year later he moved to a bigger house on the corner, 'at the Sign of the Dial and Three Crowns'. *The Nottingham Evening News* now occupies the site; the present name of the lane is Whitefriars Street. Downstairs Tompion would have had his shop where the clocks and watches he and his apprentices and journeymen made were displayed and demonstrated. Above were living quarters and a good part of the house would have been workshops.

Tompion's ability in 'mathematiks' probably saw him on the road to fame for, also about 1674, he met Robert Hooke, the first experimenter of the Royal Society, a brilliant eccentric who threw off ideas of amazing variety. Hooke had invented a quadrant for measuring the heights, angles, and distances of stars and the Royal Society told him it would pay up to £10 to have one made. Hooke heard of Tompion and passed the work to him. His diary clearly indicates that the two got on well, for he told Tompion how to make a wheel-cutting engine, and discussed many ideas from fire engines to flying machines with him.

The same quadrant was responsible for Tompion being introduced to John Flamsteed, the first Astronomer Royal, and to Sir Jonas Moore, another great scientist of the day. He often met them in coffee houses – 'Garraways' in Change Alley, Cornhill, 'Joes' in Mitre Court, Fleet Street, and 'Mans' in Chancery Lane



– which were the ‘pubs’ of the day – and was thus able to keep abreast of the latest ideas, inventions, and knowledge, and to apply them in his clocks. It is perhaps owing to the friendship of Tompion and Hooke that British clocks became supreme in the world during the eighteenth century. Hooke tells in his diary of many visits to Water Lane, when he fell in the mud, and also of times when he ‘Fel out with Tompion, who was A clownish churlish Dog or a Rascall’, but they soon made friends again and continued their discussions through the night.

When two very special clocks were needed for the Observatory at Greenwich, it was Tompion who made them. (They still exist, but reproductions are in their place in the Octagon Room today.) Astronomy is closely linked with timekeeping and Tompion had studied astronomy, on Hooke’s advice.

Tompion had four apprentices, presumably in defiance of the Clockmakers’ Company regulations. In fact, in 1656, thirty-three members of the Company presented a petition complaining about the laxity in enforcing regulations. Towards the end of the seventeenth century he had twenty people living in his household including his widowed sister, who was his housekeeper, servants, apprentices, unmarried journeymen, his niece and her clockmaker husband, Edward Banger, with whom apparently it was a ‘shot-gun marriage’. In 1696 a clockmaker named George Graham, destined also to become famous, joined the household and many years later married one of Tompion’s relatives, the daughter of his brother James.

Tompion was one of the first to number clocks from which it can be deduced that his workshops produced about 550 – eighteen or twenty a year (and about 6,000 watches! – for which he was more renowned in his lifetime). A large number of the clocks were table or bracket clocks. He was also one of the first makers to divide labour so that one clockmaker just made wheels and another dials instead of each making complete clocks. The result was a standard type of clock movement which was usually left in stock in a semi-finished state – with the expensive finishing of the wheel train and engraving of the dial not done – until a definite order was received. The cases were also standard for the regular lines, although heights varied to some extent.

Tompion used ebony for his early long cases, but never

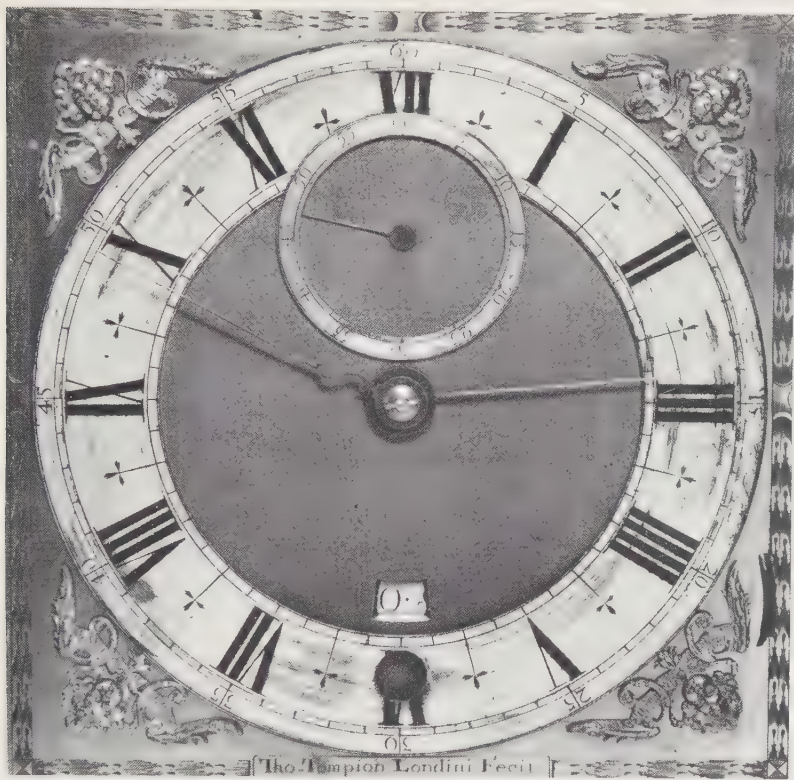

LEFT

Plate 108 Dial of a scientific longcase timepiece by Thomas Tompion, with dial and hands designed for accurate reading. The decorations still remain, however.

ABOVE

Plate 109 The famous maker, Thomas Tompion (1639–1713), reproduced from an engraving by G. Kneller.

adopted the japanned case. He stuck to figured walnut with mouldings and cross banding. The domed top was surmounted by usually plain finials.

The special clocks, like the ‘Record’ and Bath clocks, received individual attention of course and more care was lavished on details. For example, they had metal frets at the sides of the hood, backed by red or green silk, to avoid the sound of the bell being muffled. He was the first to use the break-arch dial, in 1695, a fashion that took some years to become accepted but then became established.

Tompion never spent much time on the affairs of the Clockmakers Company although he became its Master in 1703. He died at the age of seventy-four and was buried in Westminster

OPPOSITE

Plate 110 Lacquered clock with a black ground by Christopher Gould, c. 1695, which is 7 feet 8 inches tall. All minutes are numbered. The hands are particularly elaborate.

Abbey. He left his business to his 'loving Nephew', George Graham. A portrait of Tompion from an engraving of a painting by the famous portrait painter Sir Godfrey Kneller (1646–1723) is shown in Plate 109.

A contemporary of Tompion whose work approached the same level of craftsmanship was Daniel Quare, a Quaker from Somerset who, after being apprenticed and serving his two years as a journeyman, came to London and was admitted a Brother of the Clockmakers Company in 1671 at the age of twenty, when he set up in business at St Martin's-le-Grand. It was he who came into conflict with Barlow, already referred to. Quakers did not enter the professions or take work connected with the arts or music; most became tradesmen or farmers. They were pacifist and their meetings were considered a danger to the established church. Quare was frequently fined for holding illegal meetings. His workshop was at times broken into 'legally' with a sledgehammer to seize clocks and watches to pay for the maintenance of the parish priest and the militia.

Fortunately for him, he married a Quaker girl of a fairly rich family which helped him to become so established that he was even appointed clockmaker to King George I, although he refused to take the Oath of Allegiance, which had to be sworn by all entering the Palace. The difficulty was overcome by allowing him to enter by a back door, presumably used by the staff who could not be expected to swear allegiance every time they moved in and out. His renown was proclaimed by the sign of 'The King's Arms' outside the premises in Exchange Alley, which he occupied in 1680.

Quare was among the first makers of the equation clocks. He specialized in longcase clocks that ran for long periods between windings, several of them for a year, one of which is at Buckingham Palace and another at Windsor Castle. His year clocks needed only 80-lb weights to drive them and his three-month clocks only 16-lb weights for going and striking. He was also renowned for the portable barometers he invented.

He, too, became Master of the Clockmakers Company, in 1708. In later years he made one of his apprentices, Stephen Horseman, a business partner, and bought himself a country house. When he died in 1724, few newspapers of the time published an obituary notice, presumably because of his Quaker

beliefs. Horseman carried on the business but went bankrupt some years later.

Joseph Windmills, another fine clockmaker of this formative period, was admitted to the Clockmakers Company in 1671, the same year as Tompion. He is supposed to have originated the design of spandrels with two entire cupids in each, holding crossed sceptres. He was Master of the Clockmakers Company in 1702 and two years later took his son Thomas into partnership; the two usually signed their clocks 'Windmills, London'.

Edward Stanton, a Master of the Clockmakers Company in 1695, made some fine longcase clocks. He had been admitted to the Company in 1662 but despite his skill was associated with a minor scandal when another fine clockmaker, Robert Seignior, apparently persuaded him to remove the name of Henry Jones from a clock made for King Charles II which had been passed on to him for repair, and substitute his own.

Langley Bradley, Master of the Clockmakers Company in 1726, also made excellent longcase clocks but is mainly remembered for his turret clocks, principally that constructed in 1708 for St Paul's Cathedral, designed by Wren after the Great Fire.

Among the hundreds of clockmakers in London, were others of repute during the zenith of the longcase clock. They included John and William Knottesford; Richard Lyons, Master of the Clockmakers Company in 1683; Charles Gretton, who was Master in 1700 and worked at the sign of 'The Ship', in Fleet Street; Richard Street; and William Colston both of whom worked in Shoe Lane. Claude Duchesne, a Frenchman, set up in Long Acre, after joining the Clockmakers Company in 1693, incorporated musical movements in some of his tall clocks and also favoured doors panelled with Vauxhall mirror. Others were Christopher Gould (see Plate 110), admitted to the Company in 1682, who included a repeater movement in at least one of his clocks, which was grandmother size; George Etherington of 'The Dial' in Fleet Street; Jonathan Lowndes (or Lounde) of Pall Mall; John Ebsworth; Peter Garon, who went bankrupt, but made some elaborate clocks including one longcase chimer with ten changes at the hour; and Daniel Delander within Temple Bar, who had been a 'servant to (employee of) Mr Tompion', and could make clocks with equation work.



OPPOSITE LEFT

Plate 111 'Honest George' Graham, Tompion's relation by marriage, who became a famous maker, and Tompion's successor. He invented the mercury pendulum and the dead-beat escapement.

OPPOSITE RIGHT

Plate 112 Fine burr walnut case of a clock with break-arch dial and flat top by Joseph Williamson of London, who invented a special tidal dial. In the arch is a day-of-the-week dial. The clock is dated about 1725.

Prominent for their excellent and ingenious clocks were the Pinchbecks. The eldest, Christopher, moved from Clerkenwell to Fleet Street, where his workshop was under the sign of 'The Astronomico-Musical Clock' near the Leg Tavern. He, and later his second son, Edward, specialized in designing and making animated figures and scenes accompanied by bells or pipe music and announced that he also 'mends Watches and Clocks in such sort that they will perform to an Exactness which possibly thro' a defect in finishing or other Accidents they formerly could not'. The elder Pinchbeck invented the imitation gold metal still called by his name. The alloy was said 'so naturally resembles gold (as not to be distinguished by the most experienced eye) in colour, smell, and ductibility'. Its composition, a close secret at the time, is copper and zinc (as with brass) in the proportion of four to three. The eldest son was also named Christopher and made complicated clocks at Cockspur Street so successfully he was appointed Clockmaker to King George III.

The clockmaker who reached the greatest stature after Tompion's death, however, was his 'Loving Nephew', George Graham, who carried on the business at 'The Dial and Three Crowns'. Graham lost his parents when he was a child in Rigg, Cumberland, and apparently tramped all the way to London when he was only fifteen to become apprenticed to Henry Aske. After becoming a Freeman of the Clockmakers Company in 1695, he joined Tompion, soon became friendly with him and later married his niece. Undoubtedly many of Tompion's fine productions in later years were made largely under the hand of George Graham (see Plate 111).

Graham was a man of fine character who was always generous with ideas and help and, according to an obituary notice, did not seek 'the accumulation of wealth or the diffusion of his fame, but the advancement of science and the benefit of mankind'. He was known as 'Honest George Graham' and his temperament is shown in his meeting with John Harrison, the brilliant clockmaker from Barrow, who came to London with ideas for winning the Government prize of £20,000 for making a clock that would go accurately on board ship. Graham not only sat up all night discussing Harrison's timekeeper, but gave him advice, introductions, and lent him money free of interest to complete it.

In 1720, Graham was elected a member of the Royal Society,

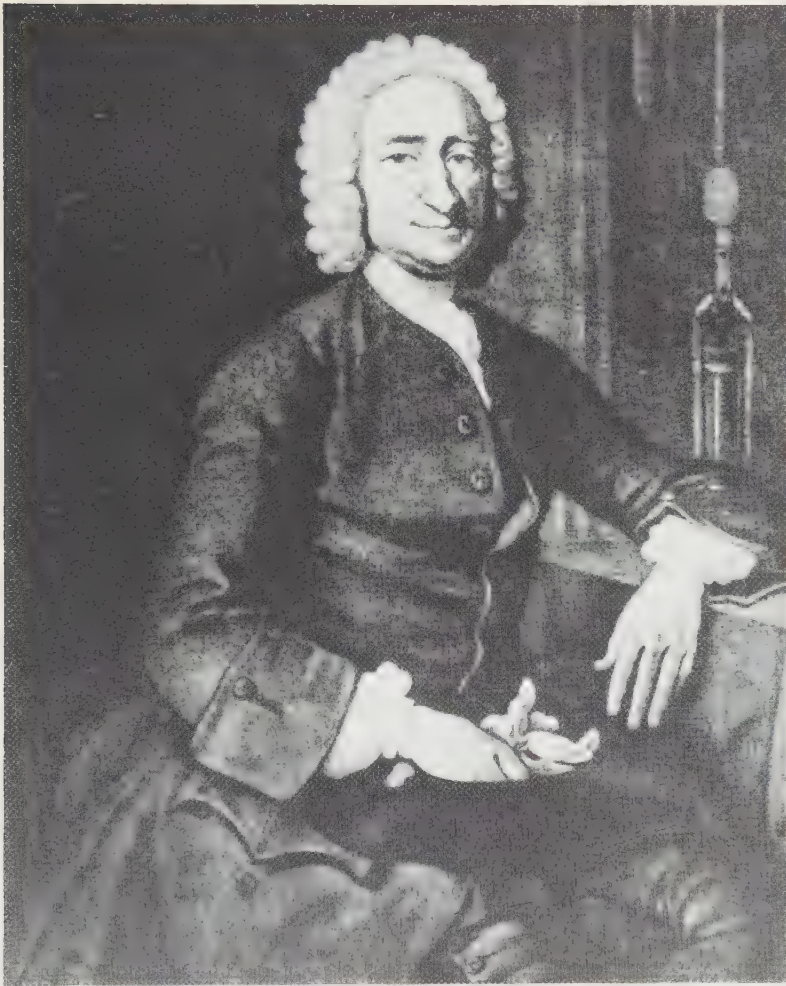

because of his mastery of astronomy. He read papers to members and invented many special instruments, but continued to produce longcase clocks in the tradition of his master. In the same year he moved to a new house at the other side of Water Lane, calling it 'The Dial and One Crown'. It had two bow windows with a door between them and two rooms above, where Graham and his wife lived, and was flanked by the Globe and Duke of Marlborough's Head Tavern. His chief contribution was to precision timekeeping by his invention of the dead-beat escapement – known as the Graham escapement – and the mercurial pendulum. His main



source of income was from a watch invention, the cylinder escapement, which had great vogue in several countries, but when he died in 1751, he had banknotes with him that were thirty years old and the whole of his worldly goods, apart from his stock in trade, were in a strongbox. He was buried in Westminster Abbey in the same grave as Thomas Tompion, which is a third of the way along the nave from the western end.

When a clockmaker died there were often attempts to take the goodwill of his business unless the inheritance was clearly established. Two of Graham's apprentices tried to assume his mantle of fame by advertising that they were his successors. One, Thomas Mudge at 'The Dial and One Crown' opposite 'The Bolt and Turn' in Fleet Street, eventually became just as famous, not for his longcase clocks but for his marine timekeepers, and because he invented the lever escapement used in every watch and most clocks today. Another was Samuel Barclay, who with Thomas Colley were Graham's executors and continued at 'The Dial and *Three Crowns*', which appeared still to be Graham's house.

Contemporary with Graham was a clockmaker who had not been given enough credit for his genius, Joseph Williamson. He specialized in equation clocks of considerable ingenuity and made the equation work for the clock supplied by Daniel Quare to King Charles II of Spain about 1694–5 – one of the first ever made, the other being by Tompion. Both clocks ran for a year at a winding. One of Williamson's own clocks showed actual solar time – not just how many minutes were to be added or deducted. To achieve this he invented differential gearing, an essential part today of countless mechanisms. This was at about the time he became Master of the Clockmakers Company in 1724, dying the following year while still in office (see Plate 112).

John Ellicott, another contemporary London clockmaker, had a son of the same name who, like Graham, became a Fellow of the Royal Society and also invented a compensation pendulum. It was not as successful as Graham's, although like Graham, he approached clockmaking problems scientifically. He was a friend of James Ferguson who invented tidal dials and he designed many public clocks.

William Webster was one more famous London name, carried on from father to son through the eighteenth century.

John Harrison, of Barrow in Lincolnshire, who went to Red Lion Square, London, at the age of forty-one in 1735, made some longcase clocks that were exceptional in being designed for precision almost regardless of the fashion of the times. He did not make them as a business, like the others, but devoted his long life to solving the problem of making clocks go on board tossing ships, for to have an accurate chronometer was the only way for a ship's captain to calculate his position east or west. Harrison is buried in Hampstead Church (see plate 113).

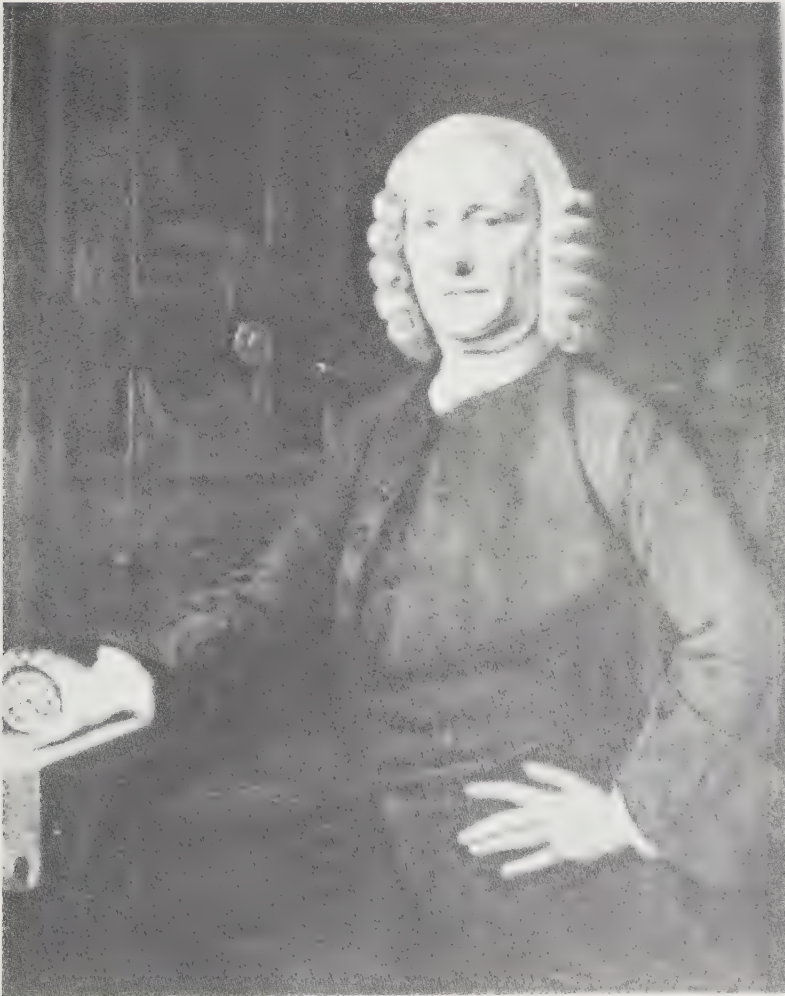
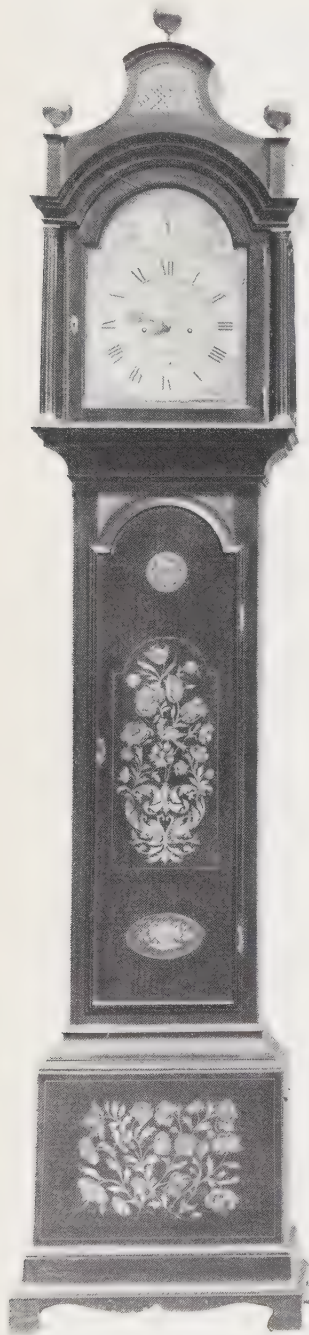

Plate 113 John Harrison, who made a few very accurate longcase clocks with wooden movements, but devoted most of his life to timekeepers for ships. He invented a much-used temperature-compensated pendulum.



After London dropped its lead in longcase clocks to concentrate on portable clocks, and provincial makers carried on the longcase tradition, it is impossible to single out all those of special merit. A few were truly outstanding. Some noted for their work were: Joshua Allsop of Northamptonshire (although he moved to London, like so many of the best makers); the Bilbie family, of Somerset; Alexander Brand of Edinburgh; John Caldwell, Appleton, Yorkshire (clock giving times of sunrise, sunset, etc.); the Chaplins of Bury St Edmunds; Charles Clay of Flockton, Yorkshire, who specialized in musical clocks; the Cockey family of Somerset, including Edward, who made astronomical tall clocks including one going for three months; Sam Collings, Downend, Bristol (musical clock with indications of solar day lengths and Ferguson tidal dial); Richard Coppinge of Bury St Edmunds; James Cowan of Edinburgh; Alexander Cumming of Edinburgh (celebrated later maker who also made fine barometers); John Cutbush, Maidstone (early maker); Samuel Deacon, Barton-in-the-Beans, Leics.; Thos. Deykin, Worcester (earlyish); Gabriel Fowkes of Dartford; Robert and Thomas Gordon, Edinburgh (both eminent makers); John Hallifax of Barnsley; Henry Hindley of York (who also invented the screw-cutting lathe and made public clocks with 56-foot pendulums); John Knibb, Oxford; Thos. Langford of Southampton; the Lawson family of Keighley and district; Benjamin Leach of Winchester; Thos. Lister (Plates 94 and 95); the Mason family of Gainsborough, Doncaster, Bawtry, in Yorkshire; Wm. Mayhew of Woodbridge (made many lacquer clocks and also Act of Parliament clocks); Richard Mills, Edinburgh; Thos. Moore, Ipswich (including musical); Thos. Moss, Frodsham (including tidal); Richard Motley, Wapping (including animation); J. Naylor, Cheshire (including astronomical); Isaac Nickals, Wells (including tidal); John Ogden, Bow Brigg, Yorkshire; John Page, Ipswich; Richard Peyton, Gloucester; Thomas Reid, Edinburgh; Henry Ward, Blandford (including equation clocks); the Washbourn family, Gloucester; Samuel Whitechurch, Bristol (including tidal); William Barker, Wigan (fine maker including complicated work); Peter Fearnley, Wigan; Archibald Coats, Wigan; Caleb Boney, Padstow, Cornwall (including astronomical); John Whitehurst of Derby (inventor of the tell-tale

OPPOSITE

Plate 114 A late eighteenth-century clock, of about 1790, which reverts to the earlier styles of marquetry and the pagoda top. It is by Alexander Cumming of London.

LEFT

Plate 115 John Ellicott, an eminent London maker, was responsible for the clock with this dial, made about 1760. It covers a precision movement with a dead-beat escapement.

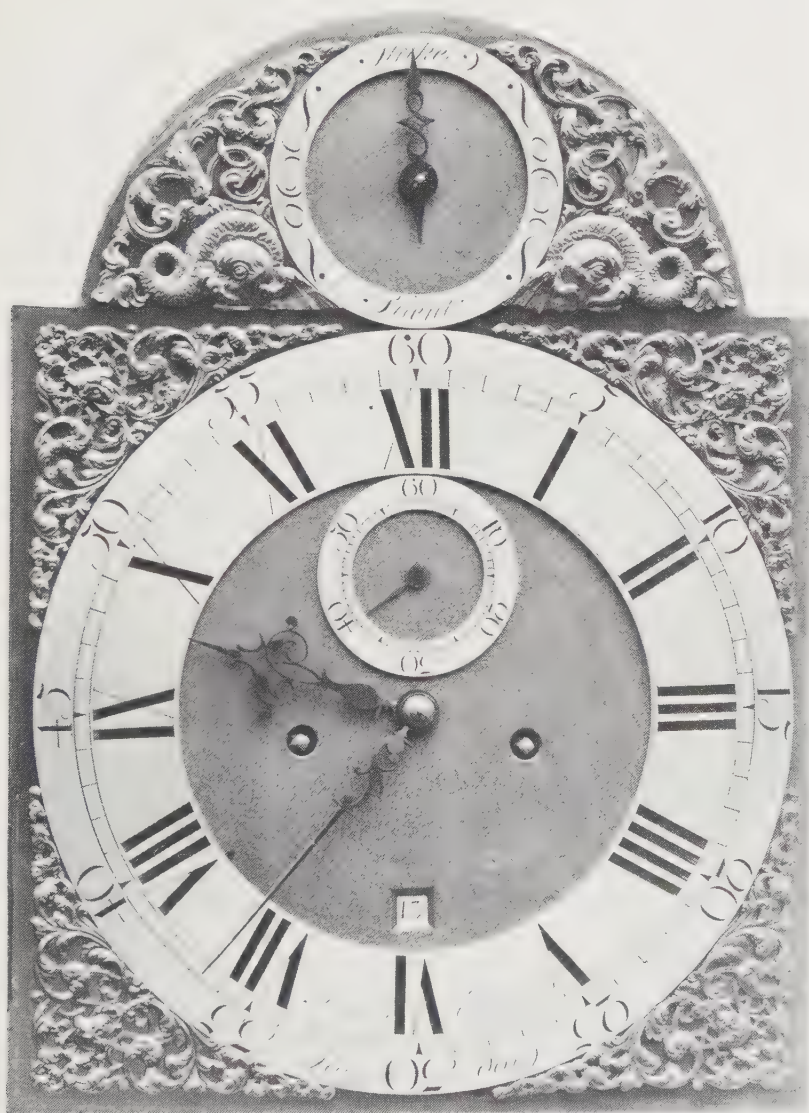

clock); B. J. Vulliamy, London (very fine later maker) and Samuel Northcott, Plymouth (including fine regulators).

An excellent picture of a provincial clockmaker's business in the second half of the eighteenth century can be obtained from the records of Samuel Deacon, which, together with his workshop of 1771, have survived virtually intact. Deacon was an important man in the community as well as a skilful maker of large chiming church clocks, watches, and longcase clocks. Because he was an accomplished musician, he seems to have specialized in musical clocks, one of which has moving figures (automata) representing the players. He was a deacon of the Baptist church and apparently an effective preacher since he was invited to preach all over the Midlands. His workshop and home were in Barton-in-the-Beans, a small hamlet in the parish of Nailstone, near Market Bosworth.

A forge on the ground floor (designed for a left-handed man) was used for ironwork, particularly of large turret clocks. Here too were many wooden patterns for casting brass wheels and iron weights. Upstairs was the workshop proper with wooden benches fitted with vices around the walls, a lathe, a wheel cutting engine, a 'horse' for holding movements under test, and a profusion of tools and material. A small partitioned area at the top of the stairs leading to the workshop formed an office and repair shop for watches and barometers. Shelves held a small library of old directories and religious works. In one corner were two enormous umbrellas for socketing into a pony trap when Samuel Deacon travelled across country in bad weather to preach or sell clocks. Over the fireplace was an oil picture of a child in early nineteenth century dress and, on a wall bracket, a weight-driven brass movement driving the hands of a painted wooden dial bearing the words DEACON 1771 on the outside wall facing the street.

In the attic above, among the debris of over a century, were Samuel Deacon's account books and workshop records together with carefully kept domestic accounts and manuscript material concerning the Baptist church. These are now in the care of the Leicester City Archivist at New Walk.

After Deacon died in 1816 at the age of seventy, his son John took over the business. He was no fine craftsman like his father and preferred to trade as a retailer, buying complete clocks bearing his name from a factory in Birmingham. He rented a shop in



Plate 116 Reconstruction of Samuel Deacon's workshop of 1771 in the Newarkes Houses Museum, Leicester, showing the wheel-cutting engine used by Deacon in 1771.

Leicester, so the clocks he sold are signed 'Deacon, Leicester', whereas those his father made are 'Deacon, Barton'. The Deacon, Leicester longcase clocks have white dials with landscape, cottage, and castle scenes in the spandrel areas. The family home remained in Barton-in-the-Beans and the workshop there was used only for repair jobs. In 1835, the shop in Leicester was closed because so much time was being devoted to Baptist activities and the workshop at Barton was more or less abandoned except for some occasional recreational activity. It remained like that until the last of the male line of Deacons decided in 1951 to sell the family home. Fortunately for posterity, this fact was noted by the archaeologist J. A. Daniell, who obtained permission to look for some old clockmaker's tools there and to his amazement found a complete workshop with all the records. He was even able to preserve the workshop so that it may be seen today as it was in 1771. The contents were carefully removed and the whole workshop reassembled in Castle View, a few yards from the Newarkes Houses Museum in Leicester (see Plates 116 and 116a).





Plate 116a Another view of Deacon's workshop showing the forge anvil and work benches.



AN ANCIENT
WORKSHOP
AND
RESTORATION TODAY

So many people today have knowledge of practical skills through their work or hobbies, that readers might like to know how the old clockmakers worked. This knowledge is also valuable to the collector, for understanding how a part was made by hand gives many clues to identification of replacements, or forgeries.

The Worshipful Company of Clockmakers, governed by an elected court of clockmakers ruled over by a Master, strictly controlled apprentices (the name is derived from the French *apprendre*, to learn), each of whom had to be indentured to a master clockmaker for seven years and live in his household. Having truly served his apprenticeship, the apprentice would be admitted a Freeman of the Company. Then for two years more he would 'serve his Master, or some other of the same Fellowship' and be allowed to live out, becoming a 'journeyman' during which time he would have to prepare a special example of his work – his masterpiece – for submission to the court. If this were approved, he could eventually set up as a master clockmaker, and take an apprentice of his own. The ordinances of the Clockmakers' Company state that on admittance a new workmaster 'shall pay to the use of the Master, Wardens, and Fellowship, the sum of twenty shillings, and to the clerk three shillings four pence, and to the beadle twelve-pence'.

A master was allowed to take a second apprentice only after the first had served five years, a restriction that irked and was commonly broken. Clockmakers sometimes worked in partnerships or groups, especially of one family, which increased the craftsmen

Der Uhrmacher.
Sind bereit, weiles Zeit.



Plate 117 A clockmaker's workshop of about 1711, illustrated by Abraham a Sancta Clara.

Last uns die güldne Stunden künften,
weil noch das Lebens-Uhrwerck geht,
eh die Gewigter schnell abläuffen,
und der bezirckte Zeiger steht;
dann andern letzten Blick der Zeit
hängt Wolund Neh der Gewigkeit 2;

to a practical working number and increased output in a greater proportion. In other parts of the country the lead of London was followed, and much the same discipline applied to makers and apprentices through local guilds.

The Worshipful Company of Clockmakers is still active today and, although it has ceased to control the industry, it has, unlike other City Companies or Guilds, a high proportion of persons connected with clock and watchmaking among its Liverymen.

An apprentice learned his trade by verbal instruction and practise. No textbooks were generally available in the seventeenth and eighteenth centuries (although a practical classic *The Artificial Clockmaker* by William Derham appeared in 1696), not because of the expense or difficulties of publication but because craftsmen jealously guarded their 'arts and mysteries' – their trade secrets. Mystery had a different meaning in those days; it is derived from the Latin word for 'work'. An apprentice would keep a personal notebook of formulae and general instructions which would be helpful in jogging his memory. His first jobs would naturally be those involving much hard work and not too much skill, such as preparing clock plates.

Plates were cast from brass, which is an alloy of copper and zinc. Clockmakers used alloys of various proportions, mostly with around seventy per cent copper which gave the alloy a rather light colour. The selected proportions of brass and zinc scrap were melted together, poured into mould trays made of sifted sand wetted with beer or water, and left to harden into sheets. Some marks of the sand and other flaws can usually be seen in clock plates produced in this way from cast sheet, and they also vary in thickness in different places. The sheets were 'set' with a special hammer on a flat stake or anvil, which flattened and work-hardened them.

Then they were filed flat, scraped to remove the file marks, and rubbed with powdered pumice and water to remove the scraper marks – a long and tedious job. One of the plates was next marked out by the master for the bearing or pivot holes and the two plates temporarily fixed together so that the holes could be drilled in both at the same time. Holes were made undersize and those for the arbors carrying the clock weights were opened up by driving in an oversize bar, or drift. This swelled the metal round the



bearing hole, hardening it and increasing the bearing area. The small bump round the bearing holes in which the winding squares run is always found in old clock movements, unless the hole has been rebushed, when a ring of different coloured brass can on some occasions be detected. Other holes had their bearing surfaces hardened by pressing in a round broach and rotating it. The broach was a polished steel bar.

It has been a practice of poor clockmakers for centuries to 'repair' worn pivot holes by punching a ring of dents round them with a centre punch, the object being to produce the opposite

Plate 118 Christiaan Huygens and his clockmaker, Salomon Coster, discuss the making of the first pendulum clock.

Reproduced by kind permission of Imperial Chemical Industries from a special painting they commissioned in 1956.



result, i.e. to close the hole. Old clock movements have not infrequently suffered from such botched repair work. The correct method is to rebush the holes.

Brass sheet, rolled to harden it, was produced commercially during the latter period of the longcase clock but rarely used by clockmakers of the time. It does, however, appear in movements or dials that have been modified or renewed and can be recognized by its consistency of thickness and surface finish and its redder colour. Almost all moulded clock parts were cast from brass; exceptions were the bells, for which bell metal – copper and tin or pewter – was employed, and the lead weights.

The front and back plates of a movement frame are united by four or often more brass pillars in early movements. These were



Plate 119 The regulator and general clock shop of S. Smith and Sons at their Clerkenwell Steam Factory in 1851.

turned with a simple bulge decoration in the middle for ornament. The pillars were normally riveted into the back plate. They projected through holes in the front plate, which rested on shoulders on the pillars. Iron or steel taper pins tapped into holes through the projecting parts of the pillars close to the plate, kept the plate in place and made the whole frame a rigid structure which could be quickly dismantled. The taper pin and hole is similar to the peg and wedge seen on very old and on some modern garden and kitchen furniture; indeed, it developed from almost identical wedges used in fourteenth-century clocks. Taper pins are also used to hold the dial plate (or false plate if one is used) to the front plate of the clock (see Plate 127). Special clocks may have latches (see Plate 85). Pins are used for the chapter ring

(see Plate 44 near the top) and taper pins are also used as a guide for the date ring in some clocks.

Near the beginning of the longcase period, a refined fastening sometimes employed on the best movements was latching. Instead of taper pins there were small plates which pivoted on pins and could be swung into slots in the pillars (see Plate 85).

Although metal screws were employed in Continental clocks as early as 1500, they did not come into use in England until about a century later, and the usual method of making joints in longcase clock movements continued to be by the more primitive, although effective, taper pin methods throughout their history. Some Midland and North Country makers, however, screwed their pillars, the screwed seating being visible through the front plate.

The short pendulum of the first longcase clocks had a small pear-shaped bob with a hole drilled through the centre (see Plate 78). A piece of pearwood was forced into the hole and the threaded pendulum rod screwed into a straight hole drilled through this so that it cut its own thread. The practice was adopted because of the difficulty of cutting internal threads. When the long pendulum came into use, the bottom end was threaded and carried a simple square nut at the bottom which could be turned to raise or lower the bob.

Most movements, until some years after mid-eighteenth century, were attached to a horizontal wooden platform in the clock case, known as the seat board, by two long screws passing through the seat board from underneath into the central boss-shaped parts of the two lower pillars. The bosses were drilled right through but only threaded part way as it was not then possible to make long internal threads. On some clocks, hook shaped bolts were used to clamp the lower pillars to the seat board (see Plate 45).

The other principal places for screws were to hold bridges or cocks to the plates of the movement and to attach the spandrels to the dial. Early screws of iron or brass were used for holding spandrels and other dial ornaments. Being screwed from the back, the ends of these can be seen on the front of the brass ornament. Threading blind holes was not attempted. The heads were simple squares, as seen at the top corners of the back of the dial plate in Plate 45.

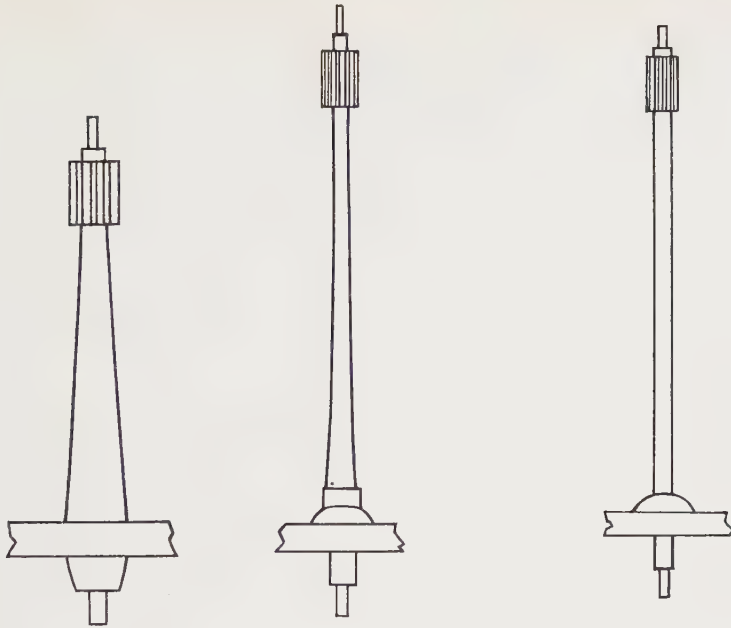

Fig. 32 The shape of the arbors of wheels and pinions will indicate the age of clocks. The earliest arbors were stubbier and tapered.

The threads of early screws were always shallow and look rounded. The earliest screw heads were square and fairly deep, with a V-shaped slot (unlike the square slot in modern screws). Screws with cone-shaped heads like inverted pudding basins were used on early longcase movements. These gave way to cheese heads, i.e. like flat discs, or hemispherical ones, on movements of the latter part of the eighteenth century. The cheese-headed screws became domed on top and the hemispherical ones became flattened into a mushroom head, thus approaching each other in shape, but the V-slot was not much improved until the end of the period.

Clock wheels – the larger driving gears – were made by casting brass into the approximate form without the teeth, which were cut after hardening the brass by hammering and finishing it in the same way as the clock plates were finished. The arbors (axles) and associated pinions (small driven gear-wheels), were made in one piece of wrought iron by forging them to rough shape by hammering them when red hot and therefore malleable. The resulting rod, with a portion of greater diameter near one end, was turned true in a primitive lathe and then grooves filed along the wider portion

to form the teeth of the pinion (the clockmaker calls them the 'leaves'), which were rounded and polished.

A larger brass wheel had to be attached to the other end of the arbor, the method being to solder a sleeve, called a 'collet', on the iron arbor and to rivet the wheel over the collet. The earliest longcase clock movements had tapered arbors and collets of various shapes, but eventually arbors became parallel and collets of simple disc shape (see Fig. 32).

Permanent fastenings other than riveting, were made by brazing both iron and brass parts. Brazing is a form of hard soldering by fusing brass into the joint, which had to be heated near to the melting temperature of the brass.

Soft soldering employing a lead-tin solder, which was much simpler than brazing as it required only a low temperature for working, but was not so strong, was introduced quite early in the eighteenth century and employed for attaching collets to their arbors, but brazing continued for stressed parts, such as striking hammer heads. In the latter half of the century, however, soft soldering ousted all brazing.

The basic tools of the clockmaker were forge and anvil, hammers, chisels, punches, files, gravers, burnishers, hacksaws, scrapers, drills, tap and screw plates, draw plates, vice, rolls, turns, throw, depthing tool, wheel-cutting engine and cutters, soldering iron, calipers and rules, compasses, and steel points for marking out. He would have a sand box for casting brass with wooden or lead patterns of various parts such as wheels, cocks, and bells, and various templates for clock plates, anchor escapement, striking rack, hands, and so on. His equipment would also include gravers, and probably many joiner's tools.

The clockmaker's drill was a simple arrangement of a flat diamond-pointed drill with a square shank, over which a small pulley fitted. A bow of cane was used to twirl it back and forth, the string of hair being given a turn round the pulley. It was held against the work by an iron plate with sockets in it to act as a bearing for the end of the drill.

Another tool was the 'turns', an elementary form of lathe, held in the vice, and still in use today in many parts of the world, even in this country by old craftsmen and restorers. The part held in the vice was a rectangular bar along which slid and could be fixed

two upright parts with opposing points or 'centres'. Between them, also adjustable, was a simple T-rest against which the tool was rested. The metal to be turned was held between the centres and twisted back and forth with a bow, like that for the drill, held in one hand. The clockmaker held the cutting tool, a tempered graver, in his other hand. It is surprising what accurate work was carried out by this primitive method, mainly because the turning was done between fixed centres and there was no wobble caused by a running bearing. Turns were developed with a rotating bearing or 'live centre', in which the work was held, and turned by means of a hand wheel, with a cord running in a groove round the rim of this and the pulley on the spindle. This was called a 'throw' and eventually developed into the lathe. The turns were retained for smaller and more accurate work.

The clockmakers' 'rolls' were like a miniature steel mangle and were used for producing flat bar or strip, the metal being annealed (softened) by heating and cooling, then forced between rollers. The draw plate was for making round or shaped bar, wire, or tubing, the softened metal being pulled through a hole in the plate, which tapered to a smaller size.

Screw threads were cut, as today, with tapered threaded taps which cut threads in a hole. Male threads were cut by means of screw plates – hardened plates with screwed holes in them – but the cutting action was so poor that the tools suffered as much as the materials being cut and the threads that resulted were shallow and varied considerably so that nuts were normally sloppy on their screws.

Another essential piece of equipment of the clockmaker was the depthing tool. In this, he could mount the arbors of two engaging gears and adjust the distance between them so that the teeth engaged accurately. One end of the tool comprised two steel points the same distance apart as the centres of the wheels. The points were used for marking the clock plate for drilling pivot holes so that the wheels would still engage correctly when fitted. The same tool was used for marking the positions of escape-wheel and anchor escapement accurately.

One of the most difficult problems encountered by early clockmakers was marking out wheels and cutting the teeth. In general the numbers of teeth divided easily into a circle; for example,

sixty-four teeth were marked out simply by dividing the circle into halves, quarters, eighths, and so on. Ingenious methods were devised for cutting a prime number of teeth, such as fifty-nine for a moon-wheel, that could not be sub-divided. The teeth themselves were cut by hand, using specially shaped files. The form of teeth for gear trains was approximately epicycloidal, a form devised by a Frenchman called Roemer, and advocated by Huygens. Drawings of tooth shapes were published in 1690, and in 1735 the French mathematician, Camus, laid down the best gear shapes for clocks and watches, to reduce friction, backlash, and the inconsistencies in the progress of the engaging gears.

In the early eighteenth century a wheel-cutting 'engine' was invented, a hand-operated apparatus which stood on the bench. The disc of brass or wrought iron in the edge of which the teeth were to be cut, i.e. the wheel blank, was fitted to a spindle. The other end of the spindle carried a large brass plate with series of concentric holes drilled in it. A circle of holes equal to the number of teeth was selected and a fixed arm with a pin fitting the holes enabled the wheel blank to be advanced the correct amount after each gap between teeth was cut. This, of course, was the forerunner of the dividing plate on the modern lathe. The tooth slots were cut by backward and forward motion of a lever holding a cutting tool, or later a rotating cutter. In the later versions, called Lancashire wheel-cutting engines, a number of wheels in a stack was cut at the same time. Thos. Tompion was one of the earliest makers to employ wheel-cutting engines regularly. Most makers in the second part of the eighteenth and in the nineteenth century would probably have bought wheels partly cut so that there was a series of slots around the periphery. They would then shape the teeth by hand file or by a cutting tool.

Early steel pinions had the leaves cut by hand, as described. It was discovered not long after 1700 that, if a draw plate were made with a hole shaped like a toothed wheel, iron wire could be drawn through it and made into a very long wire 'pinion' which could be cut into many smaller ones. Pinion wire is difficult to draw through the plate and specialist pinion wire drawers were established, one in particular in Warrington, Lancashire, a county that was the home of clock and watchmakers' tools, and supplied to all foreign centres. Pinion wire continued to be used in this

Plate 120 The J. Smith brass foundry where plates and other parts were cast.



country and was on sale in the ancient clockmaking centre of Clerkenwell in London until the 1940s.

Another major problem existed for the early clockmaker. Because the teeth of a wheel and a pinion have to engage, they must have the same pitch, like a nut and thread that mate. What then is the diameter of a wheel of seventy-five teeth that has to engage an existing pinion with eight teeth or leaves? The problem is solved by a deceptively simple instrument used by earlier clockmakers and known as a sector. It looks like two rulers hinged together at one end to form a V. If the pinion is placed in the lower part of the V where 8 is marked, the size of the wheel will be where 75 is marked on the other limb. The sector was used for measuring many other proportions as well as for sizing wheels and pinions.

For removing the marks of filing and scraping, much use was

made of powdered pumice (lava) and water; rotten stone, a mineral found in Derbyshire which was powdered and mixed with oil; and crocus or rouge, usually called 'red stuff' by the clockmaker, which was finely powdered iron oxide made into a paste with water for the final polish. Charcoal, pearl ash, and chalk were also favoured by old clockmakers. Powdered abrasive was used on a wooden stick called a 'buff', or a pad made from an old felt hat. Water of Ayr stone, a slate-like stone from Stair in Scotland, was used in the piece, with water, for rubbing out tool marks. It is still used by watchmakers and silversmiths today.

Steel and wrought iron were made more resistant to wear or damage by three methods, according to use or convenience. Iron was hardened on the surface by hammering or burnishing it (work-hardening). An alternative was case-hardening, also to provide a hard surface, and employed especially on tools. The tool was packed in an old shoe filled with a horse's hoof cut into pieces and mixed with salt. The whole was placed in a metal box, then heated to red and plunged into cold water. Steels were hardened and tempered as they are today, although, of course, they were nowhere near as consistent and the results of hardening and tempering were by no means certain.

Clockmakers of the period often took on other work such as making squares, levels, and compasses, weighing scales, barometers, astronomical and other instruments, and some jewellery work. They also tackled all kinds of repair work besides clocks and watches – ships' compasses, measures, jewellery, umbrellas – and were approached for unusual tasks because of their ingenuity. One records the manufacture of 'a tool for making pills'. A clockmaker would also do 'trade work' for others, if he were especially skilful in, say, engraving dials, or accurate brass casting.

A few horological dealers today specialize in restoration, which is not cheap because of the hand labour and the knowledge of the methods of past craftsmen, as well as the skill required in wood and metalwork. Some restorers even go to the lengths of smelting their own brass of the same composition as that used by the original master clockmaker and working it with eighteenth-century tools which leave the same tool marks as the originals. Such men, restoring valuable clocks, have even to think along the same lines as the master man of two hundred years ago when

tackling a restoration job. The foregoing remarks apply to restoration of valuable clocks – those that change hands for thousands of pounds. It is usually carried out at the instigation of the dealer and of course reflected in the final price.

The ordinary buyer of a longcase clock would not be interested in extremes of restoration, which are at the museum level. What he would want is usually reasonably simple and not costly. The first is often refilling the engraving and re-silvering the chapter ring. Many brass-dialled clocks offered for sale have had the dials polished by zealous housewives or maids, with the result that the whole is shiny brass, and some of the black wax which should fill the engraved lines is also missing. This simple restoration is well worth having done as it improves the appearance of the dial enormously. The chapter ring is removed by tapping out the taper pins that anchor it to the movement. It is cleaned and the engraved lines and numerals refilled with shellac and lamp black mixed with methylated spirits. After the filling has hardened, the entire surface is rubbed level with a fine abrasive and given a final polish. The wax is ‘glossed’ by heating the metal until the surface of the wax begins to melt. Then the ring is silvered by rubbing in a special chloride of silver paste – not by electro-plating – which produces a fine matt surface. After washing and drying, a coat of colourless lacquer is applied and the chapter ring should keep fresh and silver white for nearly half a century if it is not rubbed.

A mixture of beeswax, brick dust, and pitch is also used for filling engraving. There are, too, commercial engraver’s waxes.

All-over silvered dials naturally can be restored similarly. The method is tricky for amateurs; it is worth going to a specialist.

Old gilding that may have deteriorated is a different matter. It would have been carried out by the method of ‘fire gilding’. An amalgam of gold and mercury, which is like butter, is rubbed over the surface to be gilded, which has previously been rubbed with ‘grey powder’ – mercury and chalk. Heating to drive off the mercury, brushing, further treatments to remove superfluous mercury, and washing in acid follow. It is a most unpleasant process and the fumes are highly poisonous even at room temperature, so few, if any, craftsmen will undertake it today, and there is little chance of having such gilding renewed. This matters perhaps more to owners of all-over gilt French clocks than to those of

longcase clocks where the gilding is usually confined to spandrels and corners of dial plates. The process – also called ormolu on French clocks, after the term ‘or moulu’, meaning ‘ground gold’ – results in a granular or matt finish. The polished surface is achieved by burnishing, i.e. hard rubbing with a rounded and polished steel tool or a piece of agate. Incidentally, the process is that employed in silver-gilt; sterling silver is gilded and the gilded surfaces left matt or partly or wholly burnished. Parcel gilt refers to an article with some of its surfaces gilt and others not. What is sometimes called ‘gilding’ today is electro-plated gold on a special brass known as ‘gilding metal’.

True gilding is very enduring unless subjected to wear, so the gilt of most dials is often merely tarnished because the protective coating of clear lacquer has long since disappeared. Fortunately cleaning in soap and water is often effective and, if it is not, there is a method of restoration by using a special potassium cyanide bath, which is not so noxious as fire gilding although the fumes are poisonous. It is commonly employed by clock repairers who specialize in antique repairs. Again, it is not recommended to the amateur.

Broken hands are easily dealt with, if the parts are not lost, as they can be reunited with silver solder, not with ordinary soft solder which is insufficiently strong for small joints and will melt when bluing. The high temperature of hard soldering will destroy the colour of the hands, but they can soon be reblued to an even, dark colour by the correct use of heat. The blue hands of modern clocks are blued another way, chemically or by coloured lacquer. Blued hands that have rusted may be blackened easily by the amateur, however. Each hand should be held in the smoke of a candle or wax taper until it is quite black, then given a thin coat of clear lacquer. The lacquer must be applied gently with a water-colour brush and it is best for the clock hand to be warm so that the lacquer will not form ridges. Hang the hands on nails to dry in a warm dust-free place.

Possibly one hand has been replaced and not the other, so that the two do not match, or both have been replaced without regard to the correct period. If hands are wrong, it is often not easy to find correct replacements. Some clockmakers who specialize in antique repairs have accumulated a few genuine spare hands over



the years but, naturally, keep them for their own use. Others make accurate replicas. There are no general suppliers of antique hands. However, the amateur with skill in making models would have no great difficulty in cutting out, piercing, and carving his own replacements.

Plate 121 The clock-case shop at the J. Smith Clerkenwell factory in 1851.



CHAPTER THIRTEEN

EUROPEAN
LONGCASE
CLOCKS

Although pendulum clocks were invented in Holland, Dutch clockmakers allowed their lead in making them to be usurped by the English. Nevertheless, the Dutch made many during the eighteenth century which were generally similar to the English. Exceptions in design were a penchant for a shaped base to the wooden case, and painted decorations, even on brass dials. Dutch dials were often repainted, because as a nation the Dutch like their houses and furniture to be specklessly clean and new. A small window in the door of the trunk, so that the pendulum can be seen swinging, was common. The glass of this, however, had a metal decoration around and partly covering it.

The Dutch liked spandrels representing the seasons. They were also fond of automata in longcase (and wall) clocks, including windmills, ships rocking on rolling waves, figures of people moving to and fro, windows opening and closing with people's heads popping out, allegorical scenes, and religious scenes such as the judgement of Solomon or Abraham sacrificing Isaac. Two automata clocks are shown in Plates 122 and 123.

A favourite dial variation was a wavy minute ring on the dial; instead of there being a plain circle outside the hour numerals, there is a hump between every five-minute mark. The wavy minute ring is occasionally found on English dials. The Dutch also favoured velvet backgrounds for dials.

Austrian clockmakers were also so influenced by the English from the last quarter of the seventeenth century that some of their bracket clocks might be mistaken at a glance for English work.

Plate 122 Dial of a Dutch automata clock in a walnut case, made in the second half of the eighteenth century by Jan Hermelink, Amsterdam. Note the similar layout to the clock in Plate 123. The ships rock in the sea. The wavy minute ring is typically Dutch.



RIGHT

Plate 123 Dutch longcase clock in burr walnut with a typical bowed plinth. The movement is by Jan Henkels, Amsterdam, who was working in 1780. It shows the state of the moon, days, and months, as well as having automata of four moving ships, a woman milking a cow, and two fishermen.

FAR RIGHT

Plate 124 French mahogany regulator by Dubuisson aux Barnabites, of the late eighteenth century. The lower dial shows the time, day of the month, and sign of the Zodiac. At the top is a dial by Bourdier, showing the phases and age of the moon. The pendulum bob holds a thermometer.

OPPOSITE ABOVE

Plate 125 French longcase clock with very elaborate marquetry. Each of the twelve chapters on the dial is a separate enamel cartouche, as it was not then possible to enamel large areas, which indicates the Louis XIV period. A 13-piece dial, and then a one-piece, followed in the Louis XV period.

OPPOSITE BELOW

Plate 126 The highly coloured and embossed 'tin' pendulum of a French country clock. The pendulum is in two parts; the lower can be adjusted for regulation.



They made a form of longcase clock for some time without the benefit of the anchor escapement. The verge and crown-wheel needed a large arc of swing, so the pendulum is at the back *outside* the case and the weights are inside.

Dials of Austrian longcase clocks were usually very English in appearance with separate chapter rings and spandrels but the cases were more influenced by the French, with elaborate baroque ornaments – often of wood instead of metal – attached to them.

Austrian country makers produced a plainer type known as a 'monastery clock'. The case was narrow, violin-shaped near the middle of the trunk, and devoid of ornament. The dial was in the

English style. Austrian Empire clocks had considerable automata.

The French lagged behind the English, Dutch, and Austrians in the fashion for long cases, and their style was always highly ornamental. An elaborate marquetry clock of the Louis XV period is illustrated in Plate 125. The dial was usually round and the case tapered towards the base, having much ormolu decoration as well as marquetry. Sometimes the top of the clock holding the dial was drum-shaped and set on top of the vase as if it were a separate piece balanced there, rather like a small clock standing on a pedestal.

French country clockmakers made longcase clocks with a very large highly ornamental 'bob', roughly violin-shaped, but much longer, and with embossed and highly-coloured decoration (see Plate 126). The trunk had bulging sides to accommodate the pendulum. The dial, white and circular, was surrounded by repoussé decoration similar to that on the pendulum. The movement was a type called 'Morbier', after the district where it was made, and had an unusual system of striking. Each hour was repeated automatically about two minutes after it had been first struck.

Some of the finest French clocks, at least to English eyes, are the regulators which were made in the late eighteenth century and had plain cases with parallel sides and a glass door like their fellows over the Channel. The dial, however, was round and often behind the extra long glass door, instead of being behind a hood – a style similar to present-day master clocks used in large office buildings, except that the clock had a normal base to the trunk and stood on the floor. Others had the dial above the door, but this part of the case was the same width as the trunk and not wider, as was general in Britain. A French regulator is shown in Plate 124.

The French never employed the anchor escapement to any extent, which probably explains the slow development of their longcase clocks. They persisted with the verge for many years; then, after its invention by Amant in 1741, they enthusiastically adopted an escapement known as the pin-wheel, which requires only a small pendulum arc. Graham's dead-beat is found in French regulators, and also the gridiron pendulum invented by Harrison.





CHAPTER FOURTEEN

NORTH
AMERICAN
CLOCKS
AND MAKERS

Families which emigrated to the new colonies in North America in the seventeenth and eighteenth centuries obviously took as many as possible of their useful and valuable possessions with them, including their clocks. A lantern clock was not difficult to transport. A longcase clock was, but that did not deter even early settlers. There is a longcase clock by Fromanteel in the Library Company of Philadelphia that was owned by and may have been brought over by one of the earliest citizens of Philadelphia in the eighteenth century. In 1699, William Penn himself, after whom Pennsylvania is named, took to North America a clock by William Martin of Bristol in England. At least one maker took advantage of the need for clocks in North America, although he never emigrated. He was a Quaker named Thomas Wagstaff who offered his house at 33 Gracechurch Street, London, as lodging for Quakers from the colony. His visitors often took longcase clocks made by him back with them.

It was 1664 when Peter Stuyvesant surrendered New Amsterdam to the English and it was renamed New York. The time was after Ahasuerus Fromanteel had placed his first advertisement for pendulum clocks, and had made the first longcase clock. Although there were clockmaker settlers from Germany, Holland, Sweden, and other countries besides Britain, it was the English style that from the beginning dominated the clockmaking areas which developed along the Eastern seaboard.

The tall clock was the earliest type of clock made. Abel Cottey may have been working in Philadelphia soon after William Penn

arrived. He made the oldest surviving American longcase clock dated 1709. Another early clockmaker was another Englishman, Samuel Bispam, who is known to have owned land in the town in 1696. Immigrant makers brought with them their tools, manuscript notebooks and drawings, and some materials and parts as well as their skills. Two distinct communities soon emerged and each developed a recognizable style. One school was based on Philadelphia and the other on Boston. Some clockmakers from Philadelphia moved up the Delaware valley to New York and also spread into Virginia and Carolina. Boston clockmakers scattered all over New England, which became the states of Connecticut, Maine, Massachusetts, New Hampshire, Rhode Island, and Vermont. Both schools were important in the development of the American clock, although the early productions of the Philadelphia school are considered by American collectors to be the finer.

Another early Philadelphia clockmaker was the Quaker, Peter Stretch, apprenticed in Leek in England, who came to the colony before 1702 and at once began to make one-hand 30-hour longcase clock movements as he and his father had made them in his original home, with brass dials and cherub spandrels, particularly the type holding a crown in Plates 128 and 129. The movements were plated with pull-up winding and square dials until about 1720. After that date, Stretch made 8-day clocks also, with the same spandrels, ringed winding holes and the rather narrower style of hour hand of the period. The cases, like those for other makers, were constructed by the city's cabinet makers. Some were in mahogany and at least three that still exist with 8-day movements are identical, although with differences in the dials. Peter Stretch died in 1746 and his son carried on the business of making tall clocks until 1765. More early Philadelphia makers were the Chandlee family; Joseph Wills, who made 30-hour posted movements; and John Wood.

Philadelphia, founded in 1682, attracted wealthy people who demanded fine furniture, including clocks. Furniture making became an important industry there by 1710 with a distinctive style from about 1740. Later it came under the influence of Chippendale and, after the Revolution, Hepplewhite and Sheraton. Some cabinet makers specialized in clock cases.

The English style of clock remained predominant for many years, although there were German clockmakers in the

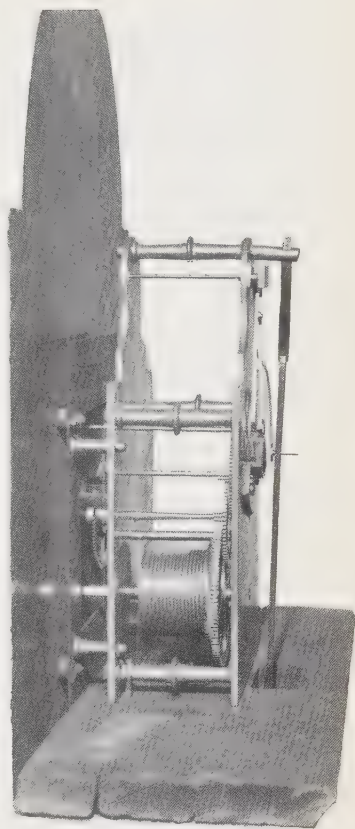

Plate 127 Movement of a timepiece by Thomas Voigt of Philadelphia, that belonged to Thomas Jefferson, third President of the USA. It has a pin-wheel escapement in the French style, and does not strike. The dial is painted, and was supplied by a dialmaker. The false plate can be seen between the dial and movement front plate. The case is of mahogany.

BELOW

Plate 128 The dial of the clock by Peter Stretch in *Plate 129*. Note the absence of minute markings, and the English spandrels of a style popular in England about 1710.

OPPOSITE LEFT

Plate 129 Early longcase clock by Peter Stretch of Pennsylvania, made before 1720. The 30-hour movement has pull-up winding, a brass dial, and one hand.

OPPOSITE CENTRE

Plate 130 Tall clock by Gawin Brown of Boston, Massachusetts, dated about 1766, in a japanned or lacquer case. It has an 8-day movement and break-arch hood with urn finials.

OPPOSITE RIGHT

Plate 131 A 30-hour tall clock by Jacob Godschalk, of Towamencin, Montgomery County, that was first, perhaps, a 'wag-on-the-wall'. The movement has wooden plates and brass wheels, and the minute hand is extra long. The case is of walnut, and is 7 feet 4 inches high.

Pennsylvanian hills, and indeed in Philadelphia itself. One of the Germans was Christopher Sauer, who came to Philadelphia in 1724 and settled in Germantown where he first worked as a tailor and then bought a farm. His wife was converted by the Seventh Day Adventists and left to join them in 1730. The shock apparently caused him to give up everything he was doing and return to Germantown, where he learned clockmaking under the instruction of a Dr Christopher Witt. He was then thirty-seven years old. He made some excellent clocks, to judge by one in the Library Company that is dated about 1735 but looks like an English clock of about thirty years earlier. It is in a walnut case with a square dial, narrow chapter ring, and hands to match, crested hood and barley twist pillars. Sauer had studied medicine in his youth so he set up as an apothecary and an optician as well. He also engaged in cabinet making, bookbinding, and paper manufacture. Finally he turned to printing, to publish the first newspaper in the German language and the first Bible ever printed in North America.

Dr Witt was as remarkable. Born in Wiltshire in England in 1675, he emigrated to America in 1704, by which time he was a physician, astronomer, herbalist, botanist, occultist, and artist. Soon after arriving he joined a group of mystics, the Pietists, led



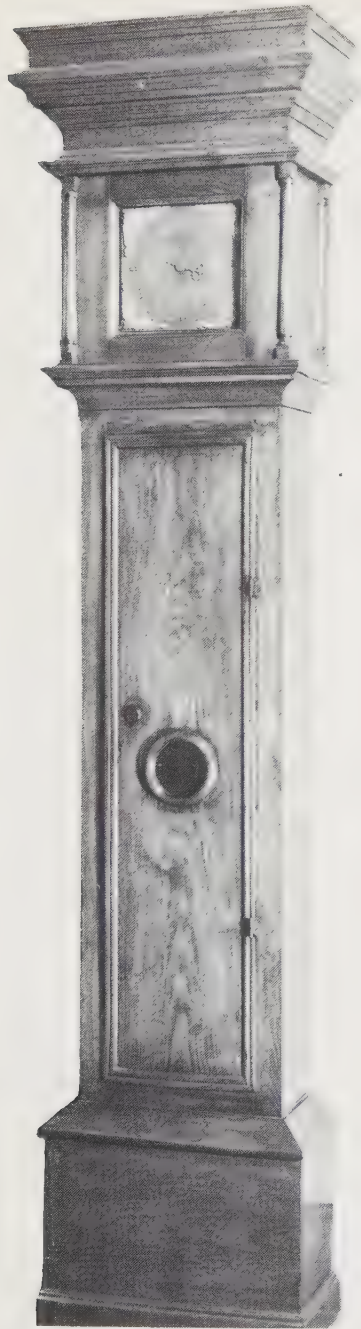

RIGHT

Plate 132 The movement of this clock was originally imported into America from England for £20, just after 1763, but the clock is apparently by Thomas Lindsay of Frankford, Pennsylvania. It was cased later when a new dial was presumably added, as the style of the dial is around 1800.

FAR RIGHT

Plate 133 American clock by Cornelius Miller, an early Jersey maker. The spandrels are not original. The movement is left rough, as cast, and not scraped, filed, or polished. Most parts, including the dial, are extremely thin. The barrels are of wood. The pendulum weight is hooked on to the pendulum rod, German style. The original lead weights classify it as a 'Tory clock'.



by a Johannes Kelpius who lived in some caves near Germantown. After Kelpius died, Witt went to live in Germantown, where he set up a telescope for astronomical observations and also cast horoscopes. Then, about 1708, he turned to clockmaking, first producing wall clocks with long pendulums and then longcase clocks, some of which still exist. In 1706 he painted a posthumous portrait of Kelpius with a wall clock in the background, one of the first, if not the first, in the colonies showing a clock.

Because of the difficulties of making some of the parts that go into a clock, some North American clockmakers bought parts from England. A major difficulty was in the shortage of brass and the copper and zinc of which it is alloyed. Clockmakers used to advertise for old metal to make clocks. It was at times easier to import cast brass wheels and other parts, including plates themselves. Sometimes efforts to save brass were made by cutting away sections of the plates. At others, the plates were made of wood and the wheels and other parts of brass and steel.

Complete movements were imported on occasion. There is a record of one purchased from England for £20 shortly after 1763. Apparently it was used without a case for forty or forty-five years, being hung on the wall with a dial. Now it is mounted in a well-proportioned, locally-made mahogany case with swan's neck cresting on the hood, a great favourite of American casemakers, and has a painted dial with seconds markings, calendar ring, and break-arch bearing a moon indication. Shown in Plate 132, it is signed Thomas Lindsay, Frankford (a town in Pennsylvania). The dial must have been changed when the movement was fitted into the case because white dials were unknown when the movement was imported. The dial itself could have been made locally or imported. The 'clockmaker' is known to have been working around 1810. One name found cast into the middle strap of a 30-hour brass movement of an American clock of about 1800 was Hepflups and Harrod, Birmingham.

One of the clockmaker's difficulties was to provide attractive dials. Specialists who could make and decorate dials, particularly painted ones, were very scarce. One such concern was Willard and Nolan of Boston, working before 1806, after which the firm became Nolan and Curtis. From about 1772 many North American makers began to rely on Birmingham in England for

OPPOSITE

Plate 134 A tall mahogany clock by Thomas Harland of Norwich, Connecticut, of about 1800, with 8-day movement and moon dial. The cresting, called 'whales' tails', is typical of Connecticut tall clocks.

their supplies. After that date, white dialmakers began to multiply.

One would have expected that the Boston Tea Party a year later, and the Revolutionary War from 1775–83, would have prevented dials from being imported, but apparently not. Osborne and Wilson were among the earliest – probably *the* earliest – Birmingham suppliers to American clockmakers. There are also dials or false plates marked Wilson and Osborne and Osborne Bros., as well as Wilson alone after 1777, according to Brooks Palmer, the well-known American horologist. After the Revolution, from about 1790, more dialmakers exported from England, including W. C. Price, S. C. Wilkes and Co., Edward Owen, and one or more of the Finnemore family. As in the case of English clocks with white dials, the dialmaker's name is often the only one on the clock. It will be found on the back of the dial or, usually, cast into the iron false plate between the dial and front plate of the movement.

The most famous maker of Philadelphia was David Rittenhouse (1732–96), who was born in Germantown and acquired an interest in clockmaking as a boy on the farm to which his family had moved. At the age of seventeen he had already established a business in Norriton (now Norristown) making accurate clocks, but continued the learning for which he had an aptitude, eventually to become secretary and then president, in succession to Benjamin Franklin, of the American Philosophical Society. He was a surveyor and an astronomer, too, and built the first American observatory. He made only about seventy-five clocks; nevertheless, clockmaking was his main source of income. Each clock had individuality and some were masterpieces of the time, particularly those with complications such as planispheres or 'orreries' showing the movement of the planets. One of his best-known clocks is in the hall of the Pennsylvania Hospital and has a month movement. In the arch is an 'orrery' showing the motions around the Sun of Uranus, Jupiter, Mars, Earth, and Venus. Other indications include the equation of time, sign of the zodiac, length of the day, and phase of the moon. The quarters and hours are sounded on two bells and one of six tunes is played on ten bells at the hour. The American Philosophical Society has an exceedingly plain longcase clock in pine made by Rittenhouse for his observatory in Norristown. What some consider Rittenhouse's most famous clock was made in 1774 and is now in the Drexel Institute

in Philadelphia. It shows six planets on its orrery as well as many other indications and plays ten tunes on fifteen bells.

The Pennsylvanian school of clockmaking did not develop far from its craft origins and when makers in Connecticut began to succeed in producing clocks by machine, it was hit so hard that by 1850 it was virtually finished.

Clockmakers in New England were as active but began to develop in different directions. In Massachusetts and Connecticut in particular there were the ideas and the drive that were eventually to lead to a huge clockmaking industry. Boston in Massachusetts was almost as important an early centre as Philadelphia, when early makers of tall clocks included Benjamin Bagnall, a Quaker from England, and Gawen Brown, who also made astronomical and tower clocks and watches.

About the time of the Révolution, four clock-making brothers named Willard came to prominence. They had eight other brothers and sisters. Apparently few of the brothers had much time for each other. The eldest, Benjamin, made longcase clocks early in his career, then turned to shelf and wall clocks.

One of the most famous of the Connecticut makers was Thomas Harland (1735–1807) whose clocks are much sought after today. He worked in Norwich and became famous for another reason; he was the first man in the world to mass produce watches with a degree of success. He is supposed to have arrived from England in one of the ships bringing tea that was destroyed by the Boston Tea Party. The first of the many apprentices trained by Harland was Daniel Burnap, who became a fine maker himself.

Mass production of clocks was made possible mainly through the activities of Eli Terry in Connecticut. After serving an apprenticeship with Daniel Burnap, now working in East Windsor, Terry probably went to work with a clockmaker-joiner who made wooden clock movements. By the age of twenty-one, Terry had set up on his own, making wooden clock movements with brass wheels, but had an early yearning to attempt mass production of clocks, probably inspired by Burnap's attempts at batch production and by the news that Eli Whitney, another production pioneer, had taken on a project to mass produce two-hundred thousand muskets for the government over a period of two years. One of his wooden movements is shown in Plate 135.



RIGHT

Plate 135 A wooden clock movement by Eli Terry in a tall clock at Yale University, east gallery. It has four pillars, and is therefore one of his earlier productions. When he began mass production, he eliminated the lower pillars, and incorporated the seatboard with the plates.

OPPOSITE

Plate 136 A grandmother clock by Joshua Wilder of Hingham, Massachusetts, of about 1810. It has an 8-day movement, and the softwood case is grained to imitate mahogany.

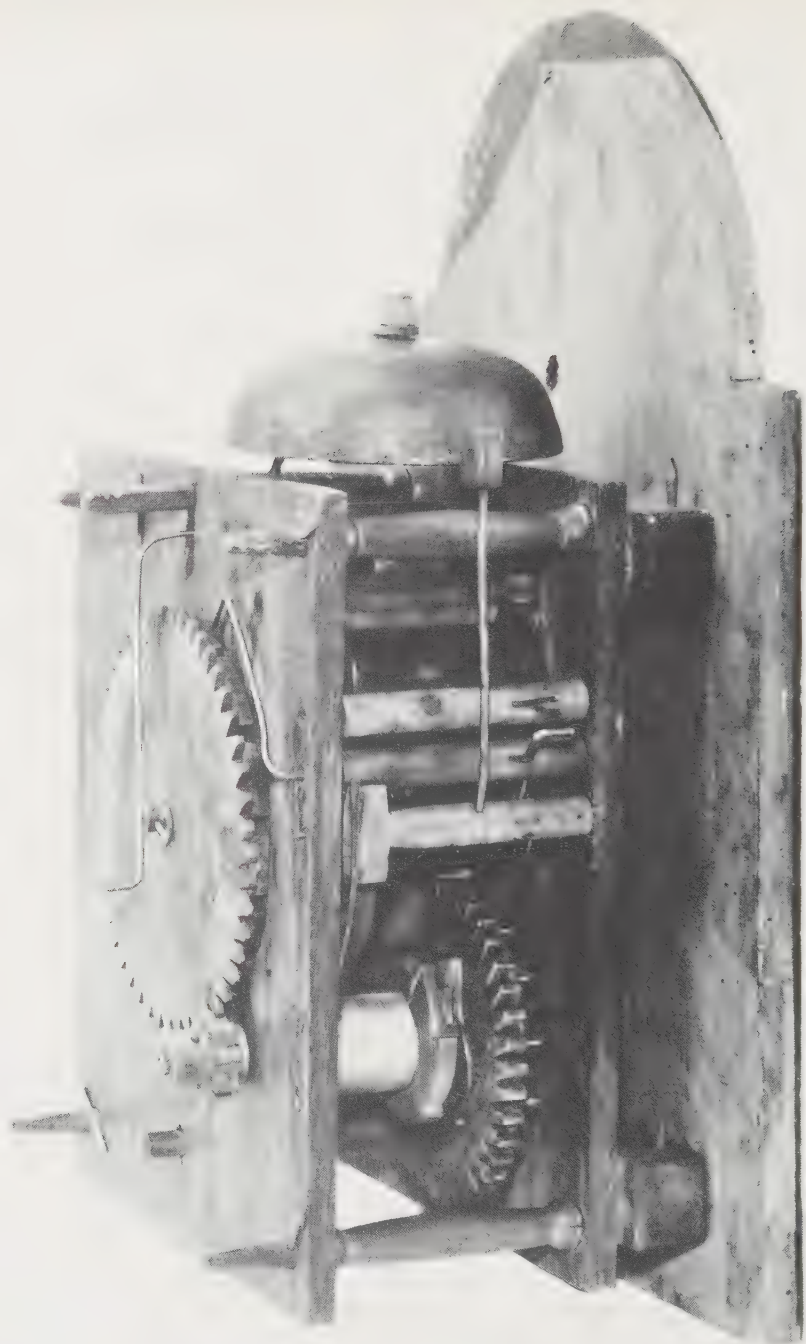

When Napoleon's blockade of England caused a severe shortage of metals in America, it was Terry's opportunity to design a wooden movement for longcase clocks that could be mass-produced in a factory driven by water power. He chose the town of Bristol near his home at Northbury for his new mill because of its river, and devised a system of jigs and fixtures for machining interchangeable wheels and other parts out of wood. He was able to do so because of the faith of two brothers, Edward and Levi Porter, who gave him a contract in 1807 to complete 4,000 movements by 1809. They supplied him with oak, laurel, and other materials, and agreed to pay \$4 a clock. It took Terry a year to set up the factory, but he completed the order on time and the clocks were a good and reliable product. He even made a profit on this original and risky venture, which was a turning point in the history of manufacture of any kind of article. Most similar pioneers bankrupted themselves.

Terry introduced two joiners, Seth Thomas and Silas Hoadley, to the business of clockmaking and formed partnerships with them, afterwards selling out to them. He went on to set up another business mass-producing the American shelf-clock, following a design possibly pioneered by the Massachusetts clockmaking brothers, Simon and Aaron Willard, who themselves probably developed it from the grandmother clock, the very short longcase clock that became popular in North America in the eighteenth and early nineteenth century. A grandmother clock appears in Plate 136. Both Seth Thomas and Silas Hoadley became famous makers in their own rights, but turned away from grandfather clocks.

Although Eli Terry is usually credited with starting mass production of longcase clock movements, there were almost certainly others working on the same lines about the same time and maybe even before him. One was John Rich who, in 1812, the year in which he died, is said to have had as many as four hundred movements in production at any one time. In East Hartford, even as soon as 1745, Benjamin Cheney Jr. began making wooden clocks in quantity and continued to do so until about 1800, but he was not an inventor of new production methods. Tall clocks with wooden movements were the main preoccupation of Connecticut makers from about 1806 to 1816.

Joseph and Chauncey Ives, two other clockmaking brothers in the area, produced wooden movements for longcase clocks, and





their elder brother, Ira, was an inventor and supplier of clock parts. One of Ira's patents was a method of making roller pinions from wood (see Plate 138). The roller pinion is a form of lantern pinion, a series of rods forming a cage with two circular ends, used by clockmakers from the thirteenth century. In the early eighteenth century, the English carpenter and clockmaking brothers, John and James Harrison, made the rods into rollers to reduce friction substantially. Ira Ives devised a roller pinion that could be made in quantity. Joseph Ives and the firm of Marrison and Dunbar turned out clocks with roller pinions. Others used wooden pinions in the same form as metal ones, with teeth.

Gideon Roberts, who probably learned about Black Forest wooden clocks from German clockmakers in the Wyoming valley of Pennsylvania where he lived, became the first Bristol clockmaker and was producing wooden movements in quantity in 1790. After 1800, he had an assembly plant in Richmond, Virginia, managed by his son.

Gideon Roberts and Riley Whiting sold movements direct to the public and the new owner would make his own arrangement about providing a case by going to a local joiner or even doing it himself. Cases were commonly made of pine or other softwood, poplar, and butternut and were often grained by painting to imitate mahogany. The dials were of wood and hand-painted or with paper dials stuck on. Some had imitation winding holes painted on, although all these cheap wooden movements ran for about thirty hours and had pull-up weights. The weight was often a cannister made of copper or tinned sheet which was filled with sand or stones. Whiting was a brother-in-law and partner of the brothers Hoadley, and when they had died, carried on making longcase clocks with wooden movements. He was possibly the last maker of them, until about 1830.

The very considerable success of Eli Terry and others in the next project of mass-producing shelf clocks with wooden movements, and then even smaller clocks with brass movements, destroyed longcase clockmaking, mass-produced as well as hand-crafted, in Connecticut as well as elsewhere in America from about 1816, except for Pennsylvania where it lingered on for a while. In the 1840s, export of extremely cheap mass-produced American shelf and mantel clocks started a rapid decline in the English and German industries. Eventually, they survived only by adopting American methods.

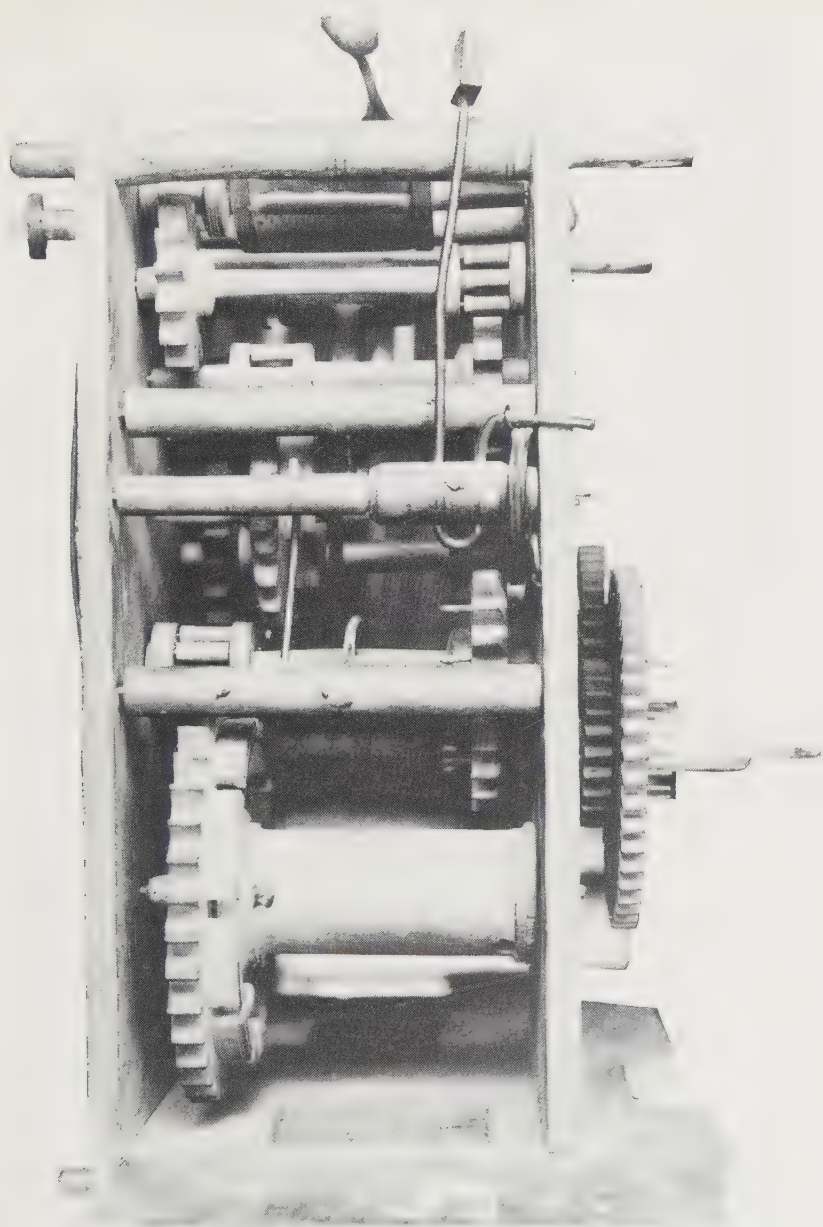

OPPOSITE

Plate 137 An 8-day clock with brass dial and moon in the arch. Note the wavy minute hand. The rather heavy mahogany case is reminiscent of the Yorkshire style of 1820-30. In England, this style of clock would have had a painted dial.

LEFT

Plate 138 Wooden-clock movement for an Ives' 30-hour longcase clock. The seatboard is incorporated, so that there are no lower pillars between the plates. Note the roller pinions.

OPPOSITE

Plate 139 A Shaker clock by Benjamin Youngs, with an 8-day movement. Youngs moved to Watervliet, New York, in 1806 when he joined the Shaker community. The case was made by Erastus Rude.

It must not be thought that longcase clocks were made only in the states and towns already mentioned. There were makers in many other places including Delaware, Maryland, Maine, Kentucky, New York, New Jersey, New Hampshire, North and South Carolina, Rhode Island, Virginia, Vermont, and Ohio.

Antique American longcase clocks can be divided into two general groups, with brass and with wooden movements. The brass ones were made in 8-day or 30-hour versions in the same patterns as English clocks, with key winding and pull-up winding respectively. Similarly, early 30-hour clocks had pillar frames. In general, wooden movements were made for 30-hour going time with the Huygens endless rope drive and a single weight for timekeeping and striking (see *Plate 135*). They had plated frames and although most had pull-up winding, some were wound through the dial. Very few wooden 8-day movements were made; Silas Hoadley produced a few.

As well as the shortage caused by the Revolution and foreign trading problems, there were patriotic attitudes to the use of metals. The pre-Revolutionary English type of clock became known as a 'Tory clock' because of its lead weights, which should have been converted into bullets (see *Plate 133*). The wooden movement seems to have originated around 1790 and at first followed the pattern of the brass original with plated frame. Wooden plates were held by four pillars pegged and glued into the front plate (as compared with riveting into brass) and projecting through holes in the back plate to be held by taper pins, but of wood. The wheels were of wood with teeth cut out by a blade or saw and the arbors and count-wheel were also of wood. Pivots, some levers, the bell hammer rod, and the crutch were made of wire and the bell itself of bell metal.

When mass production was introduced, the wooden movement was redesigned to incorporate the seatboard on which the movement normally rests and to which it is normally fixed by a screw or screwed hook. The front plate was mortised into the seatboard so that clock and seatboard became integral, leaving a shelf at the front. The back plate was made longer to overlap the back of the seatboard, to which it was attached by two pegs in the edge projecting through holes in the plate and held by cross taper pins (see *Plate 138*). A common method of attaching the dial was to make a slot in the front edge of the seatboard. A batten across the dial at the back fitted into this slot. The

mass-produced wooden movement therefore had only two pillars, between the plates at the top. The seatboard fastened them at the bottom. In some versions, the backplate was rebated into the seatboard and held by screws instead of taper pins.

Wheel teeth were first cut by means of hand tools after the teeth had been drawn on the circular wooden blank. The next method appears to have been the use of a milling cutter, a metal cutting wheel with teeth on its edge and sides which was driven by power to cut the shaped spaces between the teeth from the tip of one tooth to the tip of the next. Such clock wheels can be recognized by the horizontal grooves on the flanks of the teeth. Grooves can catch in grooves of mating teeth which creates extra friction and is a disadvantage of milled teeth. To overcome the problem, Eli Terry employed a slitting saw – a thin and small circular saw – to cut the flanks of the teeth. Usually, but not always, the two saw cuts do not meet exactly at the root of the teeth and leave a tell-tale inverted V-shaped ridge between them. In their water-powered clockmaking factories, most other makers followed Terry's example. All sawn teeth have straight flanked sides and are triangular, very different from the teeth with shaped tips cut in metal wheels. Although milled teeth do not have to be cut with straight flanks, most of them seem to have been designed that way.

Dials were hand-painted, usually by women, on wooden dial plates or painted on paper that was stuck to the wooden dial plate. Clockmakers employed printers to supply paper dials later on. This follows the practice of clockmakers in the Black Forest of Germany who had been making wooden clocks, with wooden dials and with wood and paper dials, many years earlier. North American dial designs and the general patterns of hand followed English white dial trends with Roman hour numerals and Arabic ones for the minutes and coloured decoration showing flowers, birds, patterns, and foliage in the corners and the arch. Occasionally the hour chapters were Arabic. There was no seconds hand, in common with almost all 30-hour clocks, but at times a subsidiary dial showed the day of the month.

Hands usually matched, like the hands on English white dial clocks, although some makers favoured another variety of matching hands using the pierced style of hour hand orthodox to a brass-dialled clock and a minute hand with pierced decoration about a third along



OPPOSITE

Plate 140 A 30-hour clock, 7 feet 8 inches high, by G. Miller of Germanstown, Pennsylvania, which has a 30-hour movement. Painted dials were first introduced from England about 1770. The sprays of flowers show that the style of dial here is early.

its length from the centre of the clock instead of the orthodox pointer of the brass dial. Some hands were made of pewter.

Living in sparsely populated communities, earlier American clockmakers sometimes had difficulty in disposing of their productions. The normal method of transport was on horseback as even wagons were not numerous, so the clockmaker, when short of money to buy raw materials, had to set out on horseback with four clock movements, one in each saddlebag, one on the cantle in front of him and the fourth on the pommel, in search of buyers. Often he would have to barter movements. Eli Terry records having accepted two saddlebags of pork in exchange for one of his grandfather clock movements. The buyer would often set up the clock on a wall bracket or hanging from the wall without a case and make one himself or have one made when he could afford it. Set up like this, the clock was often called 'the wag-on-the-wall'.

A number of clockmakers accepted IOUs when money was short in exchange for their productions. These became negotiable, so that they were primitive banknotes and indeed were referred to as 'clock notes'. When mass production was introduced, the problem of selling was immensely magnified. The clockmaker himself was no longer able to sell his own wares on an individual basis. Those who were not making under contract sold to special clock peddlers who called on prospective customers. The peddlers' slick sales methods became so notorious that many clockmakers stopped putting their names on their clocks to avoid damage to their reputations. Clearly this makes difficulties for collectors of early mass-produced clocks today.

Religious sects, particularly the Quakers, played a part in the history of American longcase clockmaking and are sometimes accorded special treatment in writings about horology. In truth their endeavours fitted into the overall pattern of development and should be considered with it. To illustrate how religious ideas can influence design, however, a brief sketch is given here of a small sect called the United Society of Believers in Christ's Second Coming, also called the 'Shakers' because of the members' energetic religious services in which they shook and contorted themselves in formation dances. A group of Shakers emigrated to North America from England in 1774 and about twenty colonies existed from Maine to Indiana by 1840, earning their livelihood by selling the products of agriculture

and hand crafts. Their furniture is known and admired for its extreme simplicity and careful construction. They also made clocks.

Charles Dickens visited one Shaker community in 1842 and reported on 'a grim room where several grim hats were hanging on grim pegs and the time was grimly told by a grim clock'.

The Shakers made tall or grandfather clocks (see Plate 139) as well as 'dwarf tall clocks' or grandmother clocks with brass and with wooden movements, most of them running for eight days, and four feet high or less. Metal movements often had the plates cut away to save metal. An alarm, sometimes operated by a crown wheel and verge, was incorporated in some clocks in place of hour striking. (The mechanical alarm may well have been invented originally by a religious community, around 1275, because the clock ruled all religious and secular duties.) Some grandmother clocks had inverted escapements, the escape-wheel being outside the back plate and the anchor below it. The earliest Shaker clock, dated 1789, now in the Shaker Museum at Old Chatham, New York, has a paper dial glued on wood. All others extant have dials painted on zinc or wood, such as pine.

Cases of the grandmother clocks are plain and of rather ill-proportion, but the grandfather clocks are usually quite elegant. Clock cases were never veneered or inlaid; all were constructed of solid wood, usually of pine that was stained but occasionally were of oak, walnut, cherry, or maple.

Another curiosity of the Shakers is that although the clock or timepiece was considered a vital part of their religion, a common member was not allowed to have one in his room and the watch was forbidden entirely, except to certain elders.

To sum up, the earlier history of the grandfather clock in North America followed the same pattern as its history in England and many of the remarks in other chapters of this book apply to it, with an adjustment of dates to allow for the transmission of ideas and availability of materials. The major change came through economic pressures, when the grandfather clock became the first article ever to be mass-produced successfully. But that was also its death knell because mass-production of movements for cheaper shelf and mantel clocks that followed eventually ended the day of the longcase clock not only in North America but in Europe.





CHAPTER FIFTEEN

VALUING
AND
SETTING-UP
A CLOCK

OPPOSITE

Plate 141 A month clock by Joseph Knibb, with three trains for time, quarter striking and hour striking. It is 6 feet 3 inches high with a 10-inch dial, and was made about 1690. The case is of fine figured walnut with inlays.

You may buy a clock from a private person or at an auction, in which case you have to rely upon your own judgement or outside advice. If you buy from a dealer, it is safer to buy from one who specializes in clocks. Almost invariably they give better value for money than non-horological dealers because they are careful about authenticity, having more knowledge of what they sell. Moreover, they clean and recondition antique clocks which other dealers very rarely do. As an additional safeguard it is wise to see that the dealer is a qualified member of the British Horological Institute, which guarantees his horological knowledge and skill, and of the British Antique Dealers' Association, which guarantees his antiquarian knowledge and integrity.

A clock collected from an auction room will have to be dismantled before cartage. A horological dealer will do this and set up a clock bought from him and delivered to the owner, but in many cases the owner will have to set up the clock himself.

Assuming that the clock has to be dismantled, the method is first to remove the hood, which will probably slide forward, and may have a lock reached by opening the trunk door. Don't remove the weights. Now with the door open, detach the pendulum by holding it near the top and lifting it a quarter of an inch or so. The spring should then be pushed towards the back of the case to free it and the pendulum lowered down through the hole in the crutch. If the spring does not come out of its slot in the back cock, it may be necessary to use two hands, one lifting the stop on the suspension spring out of its seating and the other taking the

weight of the pendulum (see Plate 142a). Take care, however, that the whole movement does not tip forward and fall. Now remove the weights, after marking each with chalk to identify it.

Next lift the movement, and the seatboard to which it is attached, out of the case. The seatboard will probably not be anchored to the seating of the case. If it is, and is found to be quite secure, the movement can be left in the case, but in no circumstances should the clock be moved with the weights and pendulum still attached.

It is also a wise precaution to draw the lines off the barrels to prevent their becoming tangled. To do this, after the weight is removed, of course, lift the click or ratchet with a screwdriver and pull the line from below the seatboard (see Plate 142b).

It is assumed that the new owner has found a place for the clock to stand – on a firm base with its back to a wall or pillar. The case must be steady and upright, but before checking that, the clock must be assembled.

The movement, attached to its seatboard, should be positioned so that the dial is central when the glass door of the hood is closed. The best way of adjusting it is to put your hand through the case door and move the seatboard from the back. It may be necessary to place a thin strip of wood across the seating at the back to tilt the movement forwards. There should be no unsightly gaps around the dial when the door is shut.

With the hood removed, attach the pendulum by carefully inserting it through the trunk door, up behind the seatboard, and through the crutch. The suspension spring is fed through the slit in the back cock, from the back, and pulled slightly downwards on to its seating. The pendulum should now swing freely if the clock is upright. See that the block on the pendulum below the suspension spring is free in the crutch.

Now attach the weights. The smallest, if they differ, is for the going train, that on the right of a striking clock and in the centre of a chimer. Since the lines have been pulled out, they must be wound up a little so that the pulleys are a little above the bottom of the door, but first see that the gut lines themselves are in good condition and their ends are attached securely, otherwise a falling weight might cause severe damage to the floor. The end of each gut line passes through a hole in the seatboard and is knotted –



RIGHT

Plate 142b Drawing the gut line off a barrel by lifting the click after the weight is removed.

OPPOSITE LEFT

Plate 142a Placing the pendulum spring in its cock. This is actually done facing the front of the clock, and is shown here from the back for clarity's sake.

OPPOSITE RIGHT

Plate 142c Bending the crutch without damage when setting the clock in beat. This is also done from the front in practice.

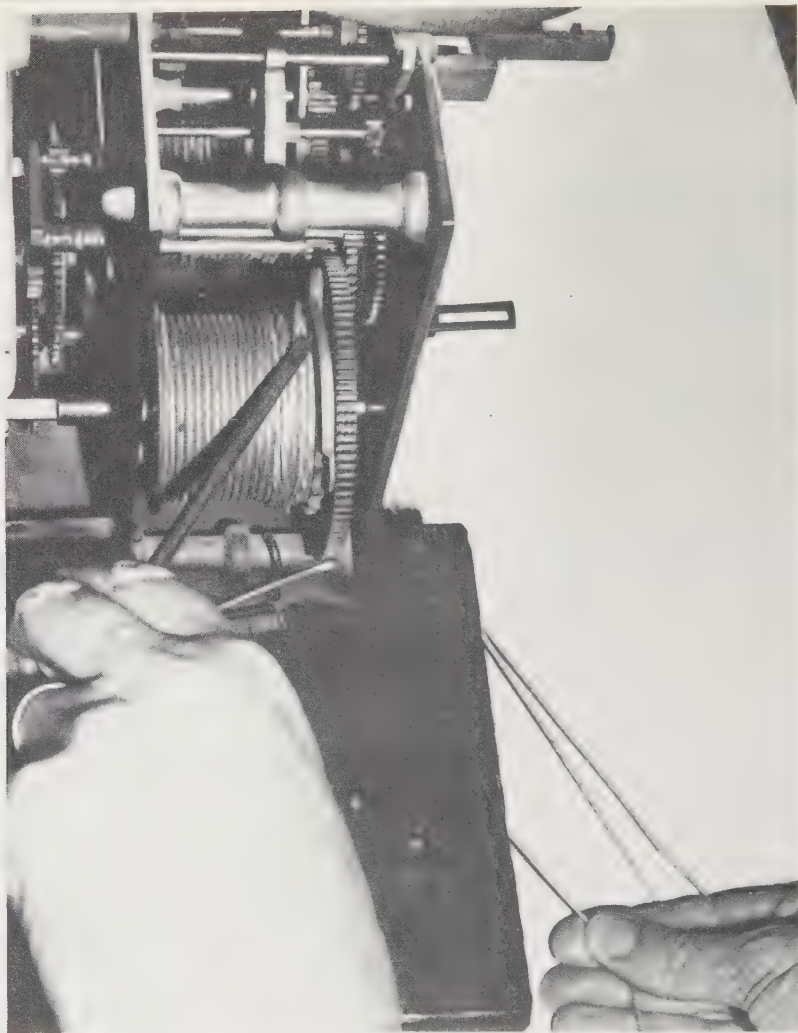

correctly by a bow – to prevent its being pulled back through. Sometimes a nail is passed through the knot as double security. When winding up the line, hold it taut while turning the key. Attach the weight, seeing that the pulley runs correctly on the line.

The next step is to judge whether the clock is upright laterally. Hang any small weight on a length of string and hold this as a plumb-line in front of the dial to see that the XII is exactly over the VI. If it is not, a thin strip of wood may have to be inserted

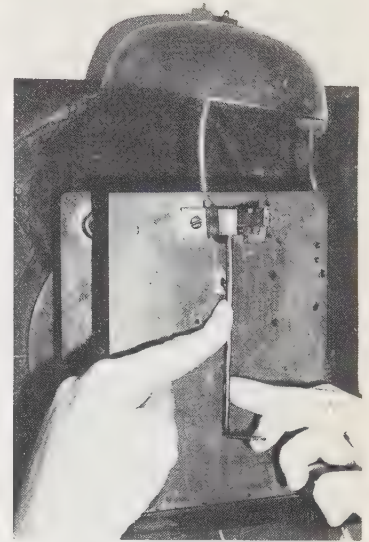
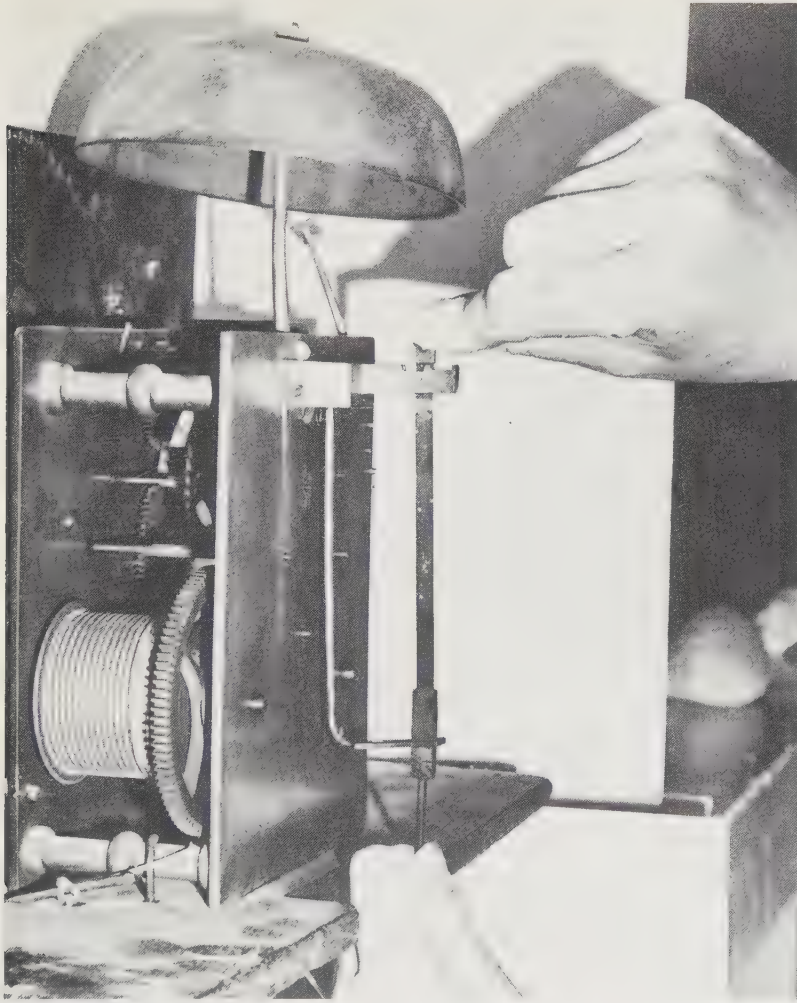

under one side of the clock case. Now check that the case is upright fore and aft by seeing that the pendulum swings in the centre of the hole in the crutch. To achieve this may also need some adjustment under the case, but if the floor is level, all should be well.

At this point the clock should be made secure. The easiest method is to employ friction. There will probably be a skirting board behind the base. If so, the case will be clear of the wall at

OPPOSITE

Plate 143 This mahogany case reminds us of an alternative name for a longcase – a coffin clock. John Holmes of London made the three-train movement with ting-tang quarter chimes. The top dial is a calendar.

the back. Cut a small piece of wood to the width of the gap approximately behind the VI o'clock position and screw or glue it to the clock case. Then tap two small wedges under the front corner of the case. This will cause it to press firmly against the wall so that it is quite rigid. The wedges are easily made from the two parts of a common clothes peg after removing the spring.

If the clock is to stand in a corner, it will be necessary to make a small wooden fitting to fill the gap. A thickish piece of board, with one end cut to a right-angled point to fit into the corner, will do, but it must be fixed firmly to the back of the clock case because there is more risk of rocking.

A hole will probably be found through the back of the case where it has been anchored in the past. Some owners screw straight through this into a wall plug, with a suitable distance piece.

The object of securing the case is not just to prevent the clock from falling or being knocked over, but to aid timekeeping. The more rigid the case, the more accurately will the pendulum swing. Occasionally a clock will stop because it is not firmly fixed. This occurs when one of the weights has descended to the same length as the pendulum and begins to swing slightly in sympathy with it, owing to very slight rocking of the clock case. The result is that energy is abstracted from the pendulum, which may come to a stop.

When the clock has been fixed upright, give the pendulum a gentle swing. The clock may start off at once and continue without adjustment. More likely, however, the pendulum will come to a stop because the movement is 'out of beat'. This means that the pendulum is not aligned with the anchor escapement. A clock that is slightly out of beat can be recognized by the fact that the ticks have an uneven rhythm. It may continue to go, but will stop at the slightest disturbance.

It is possible, but not correct, to set the clock in beat by leaning the case to one side or the other – towards the side of the quieter tick. As the case is fixed upright and more or less permanently in one place, the correct method is to bend the crutch very slightly. This must not be done by forcing it to one side or the other, which might damage the escape-wheel or break the suspension spring. The correct way is to place the first finger of one hand near the

centre of the crutch at one side and the first finger of the other hand at the bottom of the crutch at the other. The bottom finger does the bending. Your hands have to be placed round each side of the movement from the front to perform this operation. From the front, the crutch must be bent towards the louder tick (see Plate 142c).

An alternative way of finding which way the crutch must be bent (as imagined from the front, of course) is to move the pendulum by hand and note how far it has to go each side before a tick. If it has to be moved farther to the right than the left, the crutch must be bent to the left.

When the clock is going – it is assumed that it is in reasonable mechanical condition and has been oiled – it will probably keep good time. If it loses, the rating nut must be screwed up a turn or two to raise the pendulum bob, and if it gains, screwed down.

Some high-class clocks and regulators have screw adjustments each side of the crutch to replace the crude method of bending it. Adjustment screws are most common on movements with pin-wheel escapements.

Watch the pendulum swinging to see if it twists. It should not. The fault may be a kink in the suspension spring; or the bottom of the crutch through which it passes may not be exactly square to the back of the clock. By watching the crutch from the side, a short sliding motion between it and the pendulum rod may be seen. There is no such movement in a well set-up clock.

Check the striking by turning the minute hand round to XII. A few minutes before the hour, the striking train should be released and then held up again. This is known as ‘the warning’. The purpose is to free the train so that it is quickly unlocked at the hour and to make sure that the locking lever does not drop into the same notch in the count-wheel that it has just vacated, thus striking one instead of the correct number of strokes.

The striking will probably be out of phase if controlled by a locking plate, but is easily put right as explained in Chapter Four. If rack striking is fitted, the strike cannot become out of step. If, nevertheless, it is wrong, the hour hand is wrongly fitted. Turn the hands until the clock strikes, noting the number of strokes. Remove the taper pin and collet (washer) that retain the hands, and take off both hands. An hour hand fitted on a square can only be replaced to point in three other directions, one of which may be



OPPOSITE

Plate 144 A fine case in book-matched walnut, with an unusual plinth and break-arch hood. In the arch is the strike/silent controller. The zone of the dial is engraved, but the winding squares are not in the centres of the dial holes, which suggests that the movement or dial is not original.

pointing to the hour that has struck. In a great many cases, the hour hand is fitted with a friction plate and can be turned safely without removing it.

It has been assumed that the clock was bought in good going order and had been cleaned and oiled. It is worth having this done, as some pivot holes may well require rebushing. If the movement merely needs oiling, only clock oil should be used. Other oils are likely to gum up as they are not made to last a long time without oxidizing. Oil should be used very sparingly on all the pivots. A tiny spot should be placed on the pallets and another in the crutch where it bears on the pendulum rod. In no circumstances should the teeth of any of the train wheels be oiled. They should all run in a dry state. Some old pictures show a grandfather clock being oiled with a feather. It is true that farmers unused to machinery commonly used a stiff feather and some melted fat to lubricate the axles of wagons a couple of generations ago, but that is no reason for such primitive and unsatisfactory methods on precision mechanisms today. The simplest way to apply clock oil is with a length of copper wire, flattened by light hammering to a small spatula at one end. This will lift a drop of oil from the bottle sufficient to keep a pivot, going safely for many years. Over-oiling is a mistaken policy. Oil spreading over the clock may tend to draw it away from where it is needed.

There is a strange delusion among certain grandfather clock owners that a saucer of paraffin placed in the bottom of the case will keep the clock clean and lubricate it. This is an old wives' tale. Some owners place an old pillow or cushion in the bottom of the case to prevent a weight from causing damage should it fall. It probably forms an excellent breeding ground for moths, too.

Most people who buy or own a clock want to know its value. By that, they mean its *cash* value, which may be very different from its horological, artistic, or technical value. The cash value is solely determined by who wants to buy the clock. It is best estimated by a dealer, because he is most in touch with the market, or by studying priced catalogues of auction sales. The dealer should ask whether a valuation is required for insurance purposes (i.e. the replacement value) or for selling purposes; they can be very different. If a dealer gives a valuation he is entitled, like any other professional, to make a charge for the service.

Factors that determine value are as follows; the order is not significant.

1. *The age.* A general rule with orthodox clocks is: The older, the more valuable.

2. *The condition.* The better the condition, the more valuable. A small amount of restoration is acceptable.

3. *The originality.* A clock that has been heavily restored, or faked, is clearly worth less.

4. *The quality.* High quality clocks are usually, but not always, worth more.

5. *The complications.* In general again, the more indications on the clock or complications of striking, the better price it will command, but a purely technical clock, for astronomers, say, may not have any popular appeal, which would depress the price.

6. *The size.* However good a clock artistically or technically, it will not make a good price if it is huge, because only a museum or a collector with a mansion might want it.

7. *The artistic merit.* Some clock cases are beautiful, others ugly. The price is inclined to go accordingly.

8. *The wood* of which the case is made. There are current fashions in furniture woods. Few first-class clocks were made in oak, but if oak were fashionable for furniture this would keep up prices.

9. *The maker's name.* A clock bearing the name of a recognized maker is usually worth more than one without, and by a top maker more still. Big names probably push up prices more than any other factor.

10. *The length of going.* Value increases according to the length the clock will go at a winding. Thirty-hour clocks are nearly always much cheaper than 8-day ones. Month, three-month, and year movements rapidly step up the price.

There is almost as much interest in the date of a clock as in its value. The quickest way to find an approximate date, if the clock is signed, is to see if the maker is in 'the book'. That is *Watchmakers & Clockmakers of the World*, Volumes 1 and 2. If he is not named there, try the local library for a book dealing with local clockmakers. Occasionally an historian or librarian in the district has unearthed a list of names and published them. Some examples are *Clock and Watchmaking in Colchester* by Bernard

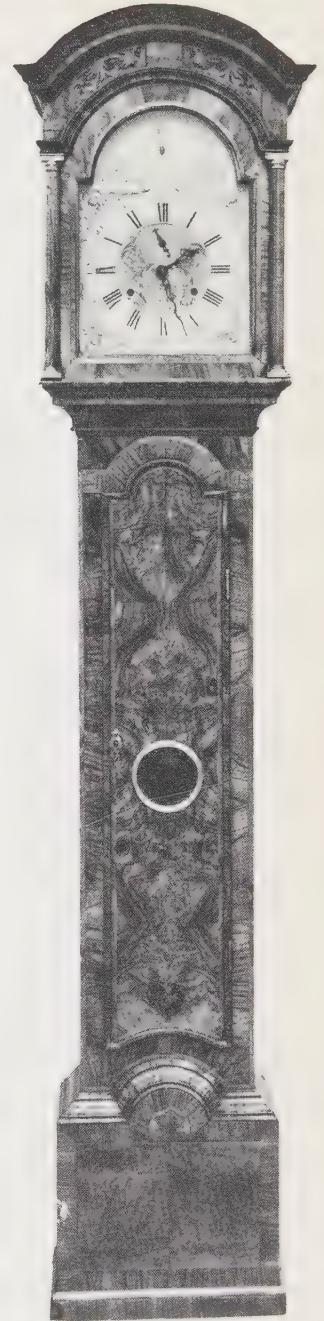

Mason, *Yorkshire Clockmakers, Lancashire Clocks and Clockmakers*, and *Westmorland Clocks and Clockmakers* by Brian Loomes, *Somerset Clockmakers*, and *Devonshire Clockmakers* by J. K. Bellchambers, *The Old Clockmakers of Yorkshire* by N. V. Dinsdale, *Cornish Clocks & Clockmakers* by H. Miles Brown, and *Clockmaking in Oxfordshire* by C. F. C. Beeson. Others are *Clock & Watchmakers in Wales* by Iorwerth C. Peate, *The Clock & Watchmakers of Wigan* by Arthur J. Hawkes, *Leicestershire Clockmakers* by John Daniell F.M.A., and *Old Scottish Clockmakers* by John Smith. There is a list of makers also in Britten's *Old Clocks and Watches and their Makers*. However, *Watchmakers and Clockmakers of the World* Volume 2 contains information up to date in 1976. For more specific information about grandfather clocks, *The Grandfather Clock* by Ernest L. Edwardes should be read and for readers interested in clocks with painted dials *The White Dial Clock* by Brian Loomes is of value.

Many local retailers and other dealers, particularly towards the end of the period, had their names engraved on the dials or plates of clocks and elsewhere – the practice is commonly encountered today with watches – and Baillie eliminated as many of these names as he could. This fact and more recent local research account for some discrepancies between different lists of makers.

Judging the date of a clock by examining it requires knowledge, some of which has been set out in this book. To help, the chart on pages 236 and 237 has been prepared, so that a quick general assessment can be attempted. It should be noted that precise dates can very rarely be put to changes, particularly those dependent upon fashion. The method of using the chart is to note the main features of the clock and see which dates includes most of them. Another important factor is the slow rate at which some new ideas spread through the country. Although the pendulum itself was adopted so rapidly throughout Britain, other technical changes and variations in cases demanded by fashion took at times as long as half a century to spread from London to the farther provinces. Readers who wish to expand their knowledge further should join the Antiquarian Horological Society, New House, High Street, Ticehurst, Wadhurst, Sussex, and in America, the National Association of Watch and Clock Collectors, Box 33, Columbia, Pa.



FAR LEFT

Plate 145 A very unusual clock by Daniel Quare, the case of which is inlaid with pewter, brass, and tortoise shell following the style set by Andre Boulle. It is 7 feet 3 inches tall, has a month movement, and was made about 1690–5.

LEFT

Plate 146 An elaborately lacquered pagoda-top case with a black ground of an imposing 9-foot high clock by William Hawkins, Bury St Edmunds, of about 1730. The background of the moon dial in the arch is star-studded.



APPENDIX I:
PENDULUM
CALCULATIONS

The formula for calculating the length of a pendulum is:

$$T = \pi \sqrt{\frac{l}{g}}$$

Where T is the time of one double vibration (half cycle) in seconds, l is the length in feet from the centre of suspension to the centre of oscillation, and g the acceleration in feet per second due to gravity.

Thus, a seconds pendulum's length is calculated as:

$$\begin{aligned} 1 &= 3.1416 \sqrt{\frac{l}{32.2}} \\ 1^2 &= \frac{(3.1416)^2 l}{32.2} \\ \therefore l &= \frac{32.2}{(3.1416)^2} \text{ ft} \\ &= 3.262 \text{ ft or } 39.14 \text{ in or } 99.42 \text{ cm} \end{aligned}$$

As π and g are constants, the length of a pendulum varies with the square of the time of swing, i.e. with T^2 . If the length of a seconds pendulum is known, the length of any other pendulum can therefore be determined by ratio. Thus h , the length of a half-seconds pendulum is:

$$\begin{aligned} l^2 : 39.14 &:: \left(\frac{1}{2}\right)^2 : h \\ \frac{1}{39.14} &= \frac{\left(\frac{1}{2}\right)^2}{h} \\ \therefore h &= 9.78 \text{ in} \end{aligned}$$

As g varies in different parts of the world, so does the time of swing of a pendulum. A longcase clock would therefore vary slightly in rate according to the value of g . This is unimportant in domestic clocks, but important in Observatory regulators.



APPENDIX II:
 DATING BY
 GENERAL
 STYLE

	1660	1675	1700	1725	1750	1775	1800	1825
<i>LONGCASE CLOCKS</i>								
By London makers (except specials)							
By provincial makers							
<i>WOODS OF CASES</i>								
Ebony veneer							
Oyster (Olive wood)							
Marquetry							
Walnut veneer							
Lacquered							
Mahogany							
Mahogany inlay							
Oak							
Soft wood							
<i>LONG CASE HOODS</i>								
Rising hood							
Sliding hood							
Convex moulding under hood							
Architectural top							
High-domed top							
Flat top and Crested top							
Pagoda top							
Broken-arch top							
Scroll top							
<i>DIALS</i>								
Brass							
Square dial							
Break-arch dial							

	1660	1675	1700	1725	1750	1775	1800	1825
With chapter rings	_____							
One-piece silvered all over							_____	
Painted							_____	
8 inches across	_____							
10 inches across		_____						
11 and 12 inches across			_____					
14 inches across							_____	
With moon dials						_____		
With tidal dials						_____		
With automata							_____	
Makers name engraved along bottom edge of dial plate	_____							
Winged cherub spandrels	_____							
Quarter-hour divisions					_____			
Half-hour decorations					_____			
Half five-minute decorations .. .					_____			
Minute divisions					_____			
Minutes marked with dots							_____	
Matted zone		_____						
Engraved zone	_____							
<i>HANDS</i>								
Hour hand only	_____							
Minute and hour hands	_____							
Seconds hand without tail		_____						
Seconds hand with tail				_____				
Centre seconds hand						_____		
Non-matching steel hands	_____						
Matching steel hands	
Matching brass hands	
Serpentine minute hand					_____			
<i>MOVEMENTS</i>								
Short pendulum in long case .. .	_____							
Long pendulum and anchor escape- ment		_____						
Locking plate striking	
Rack striking				_____				
Musical						_____		

Several features occurring in a period will give an idea of the date of a clock, but it should be noted that the horizontal lines show only general trends of fashion, except where definite inventions, such as the anchor escapement, and rack striking, are concerned.



BIBLIOGRAPHY

Books about, or including some information on, longcase clocks.

- BAILEY, C. H., *Two Hundred Years of American Clocks and Watches*, New Jersey, USA, 1976.
- BAILLIE, G. H., *Watchmakers and Clockmakers of the World*, London, 1947. (Categorized as Volume I in 1976. See Loomes.)
- BAILLIE, G. H., CLUTTON, C., and ILBERT, C. A., *Britten's Old Clocks and Watches and their Makers*, London, 1956.
- BIRD, A., *English House Clocks, 1600-1850*, Newton Abbot (Devon), 1973.
- BRUTON, E., *Antique Clocks and Clock Collecting*, London, 1974.
- BRUTON, E., *Clocks and Watches, 1400-1900*, London, 1967.
- BRUTON, E., *Clocks and Watches*, London, 1968.
- BRUTON, E., *Dictionary of Clocks and Watches*, London, 1962.
- BRUTON, E., *The Longcase Clock*, London, 1976.
- CARLE, D. DE, *Clocks and their Value*, London, 1975.
- CARLE, D. DE, *Practical Clock Repairing*, London, 1971.
- CARLE, D. DE, *Watch and Clock Encyclopedia*, London, 1975.
- CESZINSKI, H., *Old English Master Clockmakers*, London, 1938.
- CESZINSKI, H., and WEBSTER, M. R., *English Domestic Clocks*, London, 1913.
- CUMHAIL, P. G., *Investing in Clocks and Watches*, London, 1967.
- EDWARDES, E. L., *The Grandfather Clock*, Altrincham (Cheshire), 1952.
- GAZELEY, W. J., *Watch and Clock Escapements*, London, 1973.
- GORDON, G. F. C., *Clockmaking Past and Present*, London, 1946.
-

-
- JORDAN, E. V. B., and BERTELE, H. VON, *The Book of Old Clocks and Watches*, (English Ed.), London, 1964.
- LEE, R. A., *The Knibb Family, Clockmakers*, Byfleet (Surrey), 1946.
- LLOYD, H. A., *Chats on Old Clocks*, London, 1951.
- LOOMES, B., *Country Clocks and their London Origins*, Newton Abbot (Devon), 1976.
- LOOMES, B., *Watchmakers and Clockmakers of the World*, Vol. II (see Baillie), London, 1976.
- LOOMES, B., *The White Dial Clock*, Newton Abbot (Devon), 1974.
- PALMER, B., *A Treasury of American Clocks*, New York, 1967.
- PLAYER, J. W. (ed), *Britten's Watch and Clockmakers' Handbook, Dictionary and Guide*, London, 1955.
- SYMONS, R. W., *Thomas Tompion: His Life and Work*, London, 1951.
- ULLYETT, K., *In Quest of Clocks*, London, 1950.
-

INDEX



INDEX

- Abbott, Philip, Plate 27
Adamson, John, Plate 16
Agar, Plates 47 and 49
Aimer, M., Plate 13
Ainsworth, George, 160
Alarm mechanism, 122, 223
Amant, 207
anchor escapement, *see* escapement, anchor
Apprentices, 188, 190
Arbor shapes, 195 (Fig. 32), 196
Astronomical clocks, 16, 155, Plates 5 and 96
Austrian clocks, 204, 206–207
Automata, 119, 204, Plates 122 and 123
- Baillie, G. H., 166
Bain, Alexander, 156
Balance-wheel, 20–21
Banister, Joseph, Plates 37 and 56
Barclay, Samuel, 180
Barlow, Edward, 52, Plates 44 and 68
Barraud and Lund, 161
Batty, Joseph, Plates 81 and 83
Bennett, Thomas, Plate 67
Bibliography, 231–2, 238–9
Big Ben, 54, 55, 152
Bird-cage frame, 36
Bispam, Samuel, 209
Bolt and shutter device, 142, Plate 86
Booth, Edward Barlow, 171
Boulton, Matthew, 161
Bourdier, Plate 124
- Bracket clocks, 36
Bradley, Langley, 177
Brass castings, 92
Brazing, 196
Break-arch dials, *see* dials, break-arch
Break-arch hood, Plate 144
Brown, Gawin, Plate 130
Burnap, Daniel, 215
- Calendar indicators, 132, 155, Plates 66 and 67
Calendar rings, 110–11
Campani brothers, 30–31
Cases, 58 et seq., 132, 134–5;
 architectural style, 59, 62, Plates 24, 25 and 99
 carved, 71, 75, Plates 37 and 38
 Chippendale style, 64, Plate 95
 ebony, 60, 68, 174, Plates 24 and 25
 inlaid, Plate 145
 lacquered, 64, 70–71, Plates 27, 30, 31, 111, 146
 mahogany, 64, 71, 75, 132, Plates 26a, 28, 32, 36, 40, 41, 48, 101, 102, 137, 143
 maple, 76
 marquetry, 70, 207, Plate 114
 mulberry, 71, Plate 35
 oak, 71, 75, 134–5, Plates 37 and 38
 olive wood, Plate 33
 oyster, 68, Plate 33
 softwood, 135
- tiger maple, Plate 69
 veneered, 68, 71
 walnut, 68, 71, Plates 29, 34, 70, 104, 106, 112, 141, 144
 Yorkshire, 62, 76, Plates 28 and 40
Chapter ring, 80–81
Chiming clock, 53–4, 56, Plate 21
 grande sonnerie, 54
 musical, 54,
 tubular, 56, caption Plate 100
 Westminster, 54
Circular error, 33
Clare, Thomas, Plate 58
Clarke, Plate 12
Clement, William, 39–41, 95, 170, Plates 14 and 105
Click-wheels, 147
Clock clubs, 163
Clock star, 138
Clock train, *see* striking train
Clockmakers, 166 et seq.;
 provincial, 182, 184
 see also under individual names
Clockmakers' signs, 169
Clutch, 49
Coffin clock, Plate 143
Collet, 196
Concave moulding, 60
Contrate-wheel, 120
Convex moulding, 60, 64
Cooper and Hedge, Plates 19 and 31
Copernican system, Plate 4
Coster, Salomon, 32, 35–6, Plate 118
Cottage clocks, 156, Plate 97

- Cottey, Abel, 209
 Count-wheel, 51 (Fig. 10), 52
 Cox, James, 150, Plate 92
 Cresting form, 64
 Crossings, 18
 Cross-over loop, 100–101
 Crotch, Dr, 54
 Crown-wheel, 20
 Crown-wheel escapement, *see* escapement, crown-wheel
 Crutch, 33
 Cumming, Alexander, Plate 114

 Date indicators, 132, Plate 112
 Dating of clocks, 232, 236–7
 Deacon, Samuel, 136, 184–5, Plates 116 and 116a
 Deacon family, 163, 184–5
 de Dondi, John, Plate 5
 Dead-beat escapement, *see* escapement, dead-beat
 Degeneration changes, 158–60
 Dent, E. J., 152
 Derham, William, 190
 Dial markings, 80–81
 Dials, 84–6, 136, 213, 221;
 brass, 136, 163, Plates 43a–d and 83
 break-arch, 46, 84, 95, 175, Plates 17, 19, 23 and 55
 circular, 96
 convex, 97
 degrees of arc, Plates 15 and 84
 enamelled, 159–60, Plate 58
 engraved, 95, Plates 107 and 144
 fake, 163
 iron, 85, 95
 moon, 96, 111, 113–16, 118–19 (Figs. 23 and 24), Plates 32, 44 and 146
 painted, 85, 90, 95–6, 100, 136, 159–60, 163, Plates 57, 61, 62, 63 and 98
 seconds, 88, 90
 square, 84
 tidal, 116–17, 118 (Fig. 26), 119 (Fig. 27)
 twenty-four hour, 81
 white, 97, 100, 126
 Domed hood, 62, 64, Plates 26 and 54

 Dominical letter, 155
 Duboisson aux Bernabites, Plate 124
 Dutch Clocks, 204, Plates 122 and 123
 Dutch striking, 54
 Dutton brothers, Plate 52
 Dwerrhouse, Carter and Co., 161

 Earnshaw, Thomas, Plate 41
 East, Edward, 169, 171–2, Plate 22
 Eby, Jacob, Plate 49
 Eckhard, George H., 26
 Edwardes, Ernest E., 26
 Eight-day clocks, 44, 46, Plates 44 and 45;
 distinctive features, 128–9
 Electric clock, early, 156
 Ellicott, John, 180, Plates 23, 89 and 115
 Elliott, William, Plates 57 and 98
 Emery, Josiah, Plate 101
 Enamelling, 159–60
 Endless rope mechanism, 33 (Fig. 4), 46, 122, 140
 Epact, 155
 Equation clocks, 107, 108, Plate 66
 Equation kidney, 107–108
 Equation of time, 106–107 (Fig. 22), Plates 64 and 65
 Equation work, 46, 156
 Escapement, 16, 18, Plate 9;
 anchor, 39–40 (Fig. 6), 88–9, 140, Plate 14
 crown-wheel, 37
 dead-beat, 140 (Fig. 30), 146, 179, 207
 grasshopper, 144
 gravity, 146, Plate 21
 pin-wheel, 207, Plate 127
 recoil, *see under* anchor
 verge, 20–21, 32, 37
 Evans, John, Plate 21

 False plates, 160, 161, Plate 127
 Ferguson, James, 117, 118, 151
 Ferguson, John, 151
 Fire gilding, 201
 Flamsteed, John, 43, 106, 107 (Fig. 22), 117, 172
 Fly (governor), 56

 Foliot, 21, 30
 Four-wheel train, 126
 French clocks, 207, Plates 124, 125 and 126
 Frets, 64, 175, Plate 27
 Fromanteel, Ahasuerus, 34–6, 46, 62, 106, 107, 116, 120, 121, 208, Plates 11 and 12
 Fromanteel, John, 35, 53–4, 95, Plate 24
 Fromanteel family, 35, 168
 Fusee, 44

 Galilei, Galileo, 21–2, 28–30, Plates 6 and 9
 Galilei, Vincenzo, 28
 Gathering pallet, 53
 Gibson, James, Plate 55
 Gilding, 201–202
 Glass windows, 64, 66, 145, Plates 91 and 100
 Godschalk, Jacob, Plate 131
 Going train, 47 (Fig. 7), 48–9 (Fig. 8)
 Golden number, 155
 Gould, Christopher, 177, Plate 110
 Graham, George, 108, 140 (Fig. 30), 142–3, 144, 174, 178–80, Plates 87 and 111
 Graham escapement, *see* escapement, dead-beat
 Grande sonnerie, 54, Plate 22
 Grandfather clocks, 223
 Grandmother clocks, 66, 217, 223, Plate 136
 Grasshopper escapement, *see* escapement, grasshopper
 Great-wheel, 18, 122
 Greenwich Mean Time (GMT), 110, 153
 Gregg, Francis, Plate 64
 Gretton, Charles, 177, Plate 26
 Grimthorpe, Lord, Plate 21
 Groome, John, 121
 Gunter, Paul, Plates 28 and 60
 Gut line, 48, 225

 Haagsche Klokje, 24
 Half-seconds pendulum, *see* pendulum, half-seconds
 Halifax moon, 114, 155, Plates 74, 79 and 81

- Hammond, Samuel, 132
 Handley and Moore, 160
 Hands, 100–101 (Figs. 17 and 18), 221;
 finishing, 158–9
 hour, 100 (Fig. 19), 102
 materials, 101
 minute, 100–101 (Fig. 20), Plate 57
 repairing, 202
 seconds, 41, 49, 102, 136, Plates 31 and 55
 single, 80, 100
 Harland, Thomas, 215, Plate 134
 Harrison, John, 138, 142, 143–4, 146, 148, 178, 181, Plates 88 and 113
 Hawkins, William, Plate 146
 Hedge, Nathaniel, Plates 48, 51 and 82
 Henderson, R., Plate 26
 Henkels, Jan, Plate 123
 Hepflups and Harrod, 213
 Hermelink, Jan, Plate 122
 Hevelius, 30
 Hoadley, Silas, 217, 220
 Holmes, John, Plate 143
 Hooded wall clock, 36, Plate 103
 Hooke, Robert, 38–9, 172, 174
 Hoop-wheel, 53
 Horned form, 64
 Horseman, Stephen, 176–7
 Hour-wheel, 126, 128
 Huygens, Christiaan, 24, 26, 28, 32–3, 106, 107, 138–9, Plates 7, 8, 9 and 118; endless rope mechanism, 33 (Fig. 4), 46, 122, 140
 Ives brothers, 217–18, Plate 138
 Japanning, *see* lacquering
 Jones, Henry, 170
 Jukes, J., Plate 62
 Kettlewell, John, Plate 61
 Knibb, John, 95, 182, Plate 104
 Knibb, Joseph, 39, 53, 121, 167, Plates 18, 50, 76, 77, 78 and 141
 Knibb, Samuel, Plate 25
 Knibb family, 168–70
 Lacquering, 70–71, 160
 Lantern clocks, 12–13, 18–21, 36, 42, 120–21, 122, Plates 2 and 103
 Latching, 194
 Leonardo da Vinci, 32
 Lindsay, Thomas, 213, Plate 132
 Lister, Thomas, 116, 153, 154–5, Plates 74, 79, 94 and 95
 Locking plate, *see* count-wheel
 Loomes, Brian, 166, 168
 Loomes, Thomas, 35–6
 Maintaining power, 122, 142, 146–7, Plates 53 and 107
 Makers' names, display of, 95
 Making processes, 190–200; American, 220–21
 Markings, dial, 80–81
 Markwick, James, 46
 Marquetry finish, 70, Plates 16, 22, 26, 33, 42 and 54
 Martin, William, 208
 Matting (on dial), 90
 Mean time, 106
 Mercator, Nicholas, 107
 Miller, Cornelius, Plate 133
 Miller, G., Plate 140
 Minute circle, 86 (Fig. 15), 88, Plate 122
 Mirrors, 66, Plate 30
 Monastery clock, 206
 Month clocks, 34, 46, 108, Plates 66, 91, 106, 141 and 145
 Moon dials, *see* dials, moon
 Moon globes, 116 (Fig. 25), Plate 70
 Moore, John, Plate 91
 Morbier movement, 207
 Morland, Richard, Plates 59 and 80
 Motion work, 49 (Fig. 7), 126, 145–6
 Movements, wooden, 147, 148
 Mudge, Thomas, 180
 Musical clocks, 153, 155, Plate 96
 Musical trains, 54, 56
 Natural clocks, 14
 Nickals, Isaac, 182, Plate 20
 Nolan and Curtis, 213
 Numerals, 80;
 Arabic, 100, Plate 59
 Ogden, Thomas, Plate 70
 Oiling, 230
 One-hand clocks, 121, 125–6, Plates 71 and 75
 Ormolu, 202, 207
 Osborne and Wilson, 100
 Out of beat movement, 228
 Pagoda top, 64, Plates 26a, 27, 31, 114, 146
 Painted scenes, 95–6, Plates 32, 61, 62, 63
 Pallet wheel, 53
 Pallets, 20
 Parquetry, 70
 Parts, illustrated, 32 (Fig. 3), 61 (Fig. 12)
 Patterson, James, 165
 Pendulum calculations, 234–5
 Pendulum clocks, 27 (Fig. 2), 32–3, 36, 39, Plate 8
 Pendulums, 17 (Fig. 1), 22, 30–3;
 compensation, 180
 extra long, 41–2
 grid-iron, 143–4, 146, 207
 half-second, 37
 long, 38–9, 42, 120
 mercurial, 143, 146, 179
 seconds, 41
 short, 37
 tin, Plate 126
 wooden, 146
 Perpetual calendars, 111
 Perpetual motion clock, 150, Plate 92
 Pillar frame, 37 (Fig. 5)
 Pillars, 62, Plate 22
 Pinchbeck family, 178
 Pinion making, 198–9
 Planisphere, 154–5, 156
 Plate frame, 37 (Fig. 5)
 Posted frame clocks, 121–2
 Posted movement, 121, Plates 72 and 78
 Poulton, William, and Son, Plate 36
 Pull-up winding, 46, 124
 Quare, Daniel, 53, 108, 156, 171, 176, Plates 65 and 145
 Rack striking, 52 (Fig. 11), 129, 171
 Railway time, 110

- Rating nut, 143
 Recoil escapement, *see* escapement, anchor
 'Regulator', 34, 120
 regulator clocks, 49, 76, 138–48, Plates 41, 84, 89 and 90
 Reid and Auld, 161
 Rennington, Robert, Plate 90
 Repeating work, 52
 Restoration, 164, 200–203
 Rising hood, 60, 62, Plate 24a
 Rittenhouse, David, 214
 Roberts, Gideon, 218
 Roman striking, 53
 Royal Pendulum, *see* Pendulum, seconds
 Rude, Erastus, Plate 139
- Sauer, Christopher, 210
 Screws, 194–5
 Seatboard, 194, 220–21, Plates 135 and 138
 Seconds pendulum, *see* pendulum, seconds
 Seconds ring, 90
 Sector (tool), 199
 Setting-up, 224–30, Plates 142a, b and c
 Shake minutes clock, 128
 Shakers, 222–3
 Sidereal time, 156
 Single hand clocks, 125–6
 Six-month clocks, 46
 Skikelthorpe, W., Plate 34
 Smith, John, 106
 Smith, John, and Sons, 160, Plates 100, 119, 120, 121
 Smorthwait, John, Plates 2 and 75
 Snow, Richard, Plates 40 and 62
 Spandrels:
 cast, 92
 decoration, 90 (Fig. 16), 91–2, Plates 77, 105, 107 and 125
 manufacture, 158
 painted, 95–6
 Spoon (trigger), 60
 Staff (axle), 20
- Stanton, Edward, 177
 Star map, 154
 Stretch, Peter, 209, Plates 128 and 129
 Striking action, 53
 adjustment, 51
 Dutch, 54
 Roman, 53
 ting-tang, 53
 train, 48 (Fig. 8), 51
 Su Sung, 16
 Sundials, 104, 106, 108
 Swan's neck form, 64, Plate 32
- Taper pins, 193–4
 Tell-tale clocks, 150–51, Plate 93
 Temperature effects, 142–3
 Terry, Eli, 215, 217, 221, 222, Plate 135
 Thirty-hour clocks, 44, 46, 52, 120 et seq. (Figs. 28 and 29), Plates 77 and 78; differences, 128–9
 Three-month clocks, 46, Plate 84
 Three-wheel train, 126–7 (Fig. 28)
 Thwaites and Reed, 160, 161
 Tidal dials, *see* dials, tidal
 Time zones, 153
 Ting-tang, 53–4
 Tompion, Thomas, 39, 42, 46, 81, 84, 108, 117, 121, 125, 171–2, 174–6, Plates 15, 17, 33, 35, 53, 66, 84, 85, 86, 106, 107, 108 and 109
 Tooley, M. V., Plate 42
 Tools, traditional, 196–200
 Tory clocks, 220, Plate 133
 Two-hand clocks, 125–6, 128
- Valuation, 230–31
 Veneering, 68, 70
 Verge, 20
 Verge escapement, *see* escapement, verge
 Vick, Henri de, 80
 Viviani, 28–9
 Voigt, Thomas, 209
 Vulliamy, Benjamin, 144, 152, 161, Plate 99
- Wag-on-the-wall clocks, 222, Plate 131
 Wagstaff, Thomas, 208
 Walker, Thomas, Plate 46
 Walker and Finnemoore, 160
 Wall clocks, 36
 Warning, 53, 229
 Watch train, *see* going train
 Watchman's clocks, 150, 151, Plate 93
 Wayland, John, Plate 29
 Webster, William, Plate 30
 Weights, 47, 147
 Westminster chime, 54
 'Whales' tails' decoration, Plates 20 and 134
 Wheel cutting, 197–8, 221
 Whitehurst, John, 150–51, 152, 160, 182, Plate 93
 Whitehurst and Son, 161
 Wilder, Joshua, Plate 136
 Willard and Nolan, 213
 Willard brothers, 215, 217
 Williamson, Joseph, 108, 111, 180, Plates 39 and 112
 Winding, 46, 140, 142, 148
 Winding holes, dummy, 124–5, 136, Plates 81 and 83
 Windmills, Joseph, 177, Plate 54
 Winterbourne, Joseph, 155–6, Plate 96
 Witt, Christopher, 210, 213
 Wooden movements, 144, 147, 148, 220, Plates 88, 135 and 138
 Woods, 68, 71, 134–5; *see also under* Cases
 Workshops, 184, 185, Plates 116, 116a, 117 and 119
 World time dial, 153
 Worshipful Company of Clock-makers, 35, 168, 171, 172, 174, 175, 176, 177, 180, 188, 190
- Year clocks, 34, 46, Plate 17, caption Plate 66
 Yorkshire case, *see* cases, Yorkshire
 Youngs, Benjamin, Plate 139

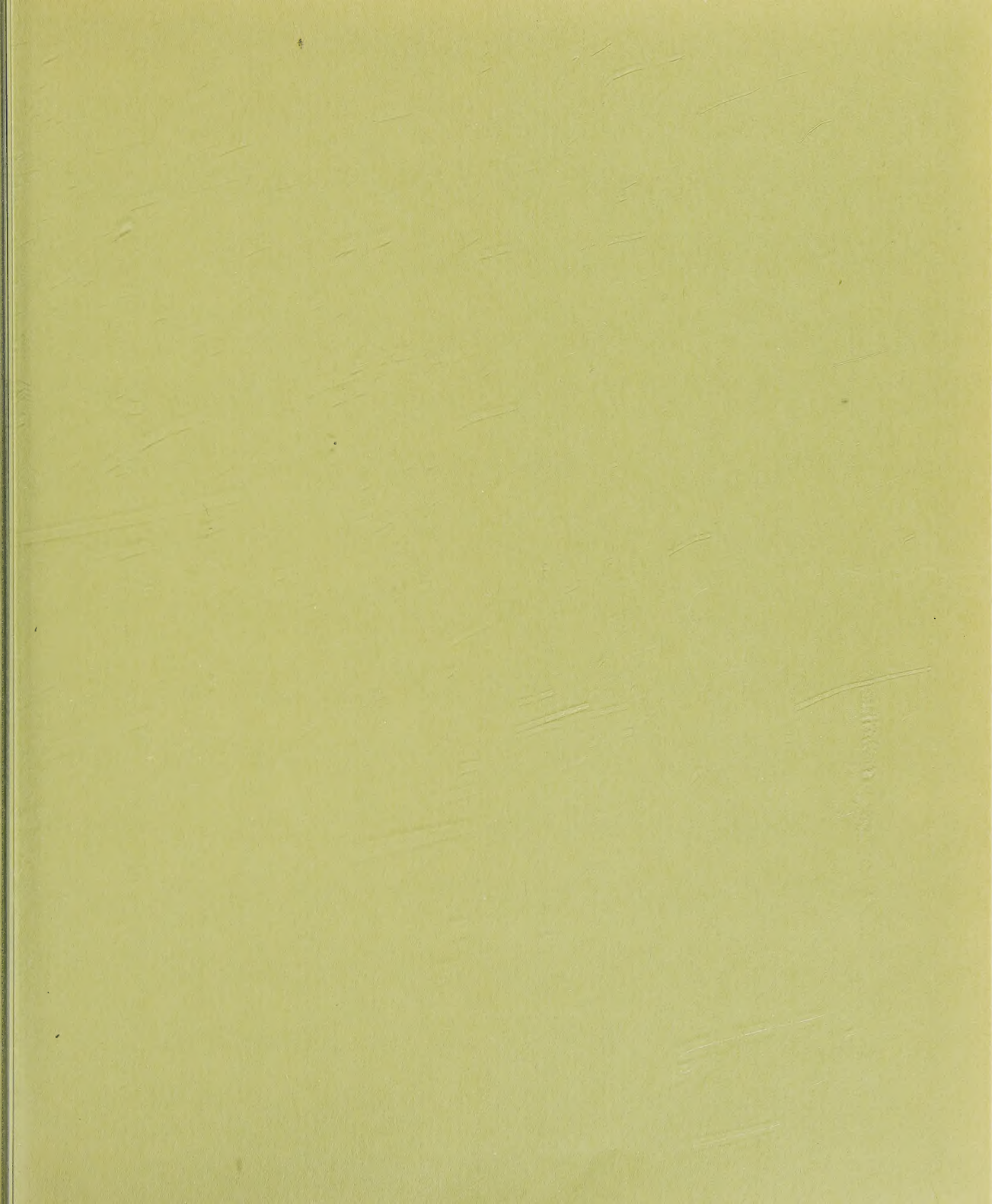



With the exception of six years as an engineer officer in the RAF, Eric Bruton has spent most of his life in activities concerned with clocks and diamonds – writing about them, teaching in related subjects, and trading in them.

He is a Fellow and past councillor of the British Horological Institute, a Fellow and present councillor of the Gemmological Association of Great Britain, and a Liveryman of the Worshipful Company of Clockmakers as well as the Worshipful Company of Turners.

Author of over twenty books, including **A Dictionary of Clocks and Watches ; Clocks and Watches : 1400-1900**, and **Diamonds**, he was co-founder of *Retail Jeweller*, the jewellery trade's newspaper, and is the owner of two shops in the trade.



Published by
CHARLES SCRIBNER'S SONS
New York

ISBN 0-684-16247-4

Front jacket shows a rare burr-walnut Longcase Clock by Fromanteel and Clarke. c.1710:
by courtesy of Meyrick Neilson of Tetbury Ltd.

Back jacket photograph is reproduced by courtesy of Johann Klein

