

Vol. XIV No. 6

April, 1975

# THE JOURNAL OF GEMMOLOGY

*and*

PROCEEDINGS OF THE  
GEMMOLOGICAL  
ASSOCIATION  
OF GREAT BRITAIN



---

GEMMOLOGICAL ASSOCIATION  
OF GREAT BRITAIN  
SAINT DUNSTAN'S HOUSE, CAREY LANE  
LONDON, EC2V 8AB

# GEMMOLOGICAL ASSOCIATION OF GREAT BRITAIN

(Originally founded in 1908 as the Education  
Committee of the National Association of Goldsmiths;  
reconstituted in 1931 as the Gemmological Association)

## OFFICERS AND COUNCIL

*President:*

G. F. Claringbull, Ph.D., F.Inst.P., F.G.S.

*Chairman:*

Norman Harper, F.G.A.

*Vice-Chairman:* D. N. King, F.G.A.

*Treasurer:* F. E. Lawson Clarke, F.G.A.

*Elected Fellows:*

M. Asprey

Iris Hopkins

T. Bevis-Smith

D. G. Kent

E. Bruton

M. J. O'Donoghue, M.A.

D. J. Ewing

P. W. T. Riley

*Examiners:*

B. W. Anderson, B.Sc., F.G.A.      J. R. H. Chisholm, M.A., F.G.A.

A. J. Allnutt, Ph.D., F.G.A.                      M. Font-Altaba, D.Sc.

J. M. Bosch-Figueroa, D.Sc.      Toini A. Mikkola, L.Phil., F.G.A.

Marjatta Virkkunen, M.Phil., F.G.A.      H. Judith Milledge, D.Sc.

E. A. Jobbins, B.Sc., F.G.A.                      A. E. Farn, F.G.A.

*Instructors:*

R. Webster, F.G.A.

S. B. Nikon Cooper, B.D., F.G.A.

Vera Hinton, F.G.A.

H. J. Whitehead, F.G.A.

P. A. Waters, F.G.A.

*Editor:* J. R. H. Chisholm, M.A., F.G.A.

*Curator:* R. Webster, F.G.A.

*Librarian:* G. F. Andrews, F.G.A.

*Secretary:* H. Wheeler, F.G.A.

*Assistant Secretary:* D. Wheeler, F.G.A.

**Saint Dunstan's House, Carey Lane, London, EC2V 8AB**

**(By Goldsmiths' Hall)**

*Telephone: 01-606 5025*

---

**Affiliated Associations: Gemmological Association of Australia;  
Canadian Gemmological Association; Rhodesian Gem and Mineral  
Society.**

# THE JOURNAL OF GEMMOLOGY

AND PROCEEDINGS OF THE  
GEMMOLOGICAL ASSOCIATION  
OF GREAT BRITAIN

Vol. XIV No. 6

APRIL 1975

## TWENTY-FIVE YEARS

By B. W. ANDERSON, B.Sc., F.G.A.

*(being the substance of a talk given to the Gemmological Association of Great Britain at Goldsmiths' Hall on 9th October, 1974.)*

THIS evening I am going to continue the history of the Precious Stone Laboratory from the point where I left it in my two previous talks,\* that is, at the end of the Second World War. Twenty-five years is a long period to review in the space of an hour, so I will plunge straight in with my story.

On the 3rd September, 1945, almost exactly six years after being called to serve as a gunner, my old colleague, C. J. Payne, returned to work in the Laboratory. I was mighty glad to have him again at my side—partly, of course, for personal reasons, since for those six long years I had ploughed a lonely furrow in the Lab., with no one to share my gemmological problems and excitements, but also because I was by then a tired man and finding it impossible to cope with the thousands of pearls and other work which was coming in for testing. Working all day at the Endoscope may not be most people's idea of heaven, but for James Payne, after the uncongenial life of the army, it was a thoroughly welcome change, and with his vigorous assistance the back-log of pearls was soon brought under control and I was even able to take a short holiday.

Before many months elapsed, however, the Laboratory was called upon to face a new and formidable challenge. As most of

\**J. Gemm.*, 1973, XIII (7), 249-262; 1974, XIV (3), 97-113.—Ed.

you realize, the well-being of our trade depends upon the chain of confidence which exists all along the line from the rough gemstone to the finished jewel. If the first link in this chain were found to be faulty, the seeds of chaos were sown. In my first talk I recounted how in 1925 it was the infiltration of cultured pearls into the hitherto sacrosanct "Bombay bunches" which had forced the pearl traders of London and Paris to devise special apparatus and establish special laboratories to check on the purity of their supplies. Now, 21 years later, it had become increasingly apparent that parcels of rubies and sapphires—particularly those in small calibré sizes—which were imported from Burma from sources hitherto completely reliable were likely to contain anything up to about 10% of synthetic stones. This unwelcome truth had become established beyond doubt when eternity rings, bracelets, bar brooches and the like utilizing such stones were found again and again to contain the odd synthetic stone or two, which then had to be winkled out and replaced, and the customer placated. Obviously the only remedy for this dire situation was to have *all* stones in this category tested before they were released into the trade. Equally clearly this was a task beyond the capacity of a war-battered, ill-equipped laboratory, staffed by only two gemmologists (already fully occupied with the ordinary routine testing of pearls, stones and jewellery which formed the bread and butter of the trade) and a commissionaire.

Accordingly, I was approached by Mr Fred Ward on behalf of the Standing Committee of the Diamond, Pearl, and Precious Stone Trade Section of the London Chamber of Commerce, and asked whether, given the extra staff and any necessary apparatus, I thought the job could be done? Obviously this was a challenge that had to be met, and the answer just had to be "yes". A re-equipment fund was launched and generously supported, and I was free to seek out and purchase the instruments most urgently needed. Microscopes, of course, were the first essential. Until that time we had subsisted, incredible though it now seems, on two venerable Swift instruments, one a Wenham binocular and the other a petrological microscope. Luckily in those days one was in the happy position (which was taken entirely for granted) of being able to walk into any of several microscope makers' showrooms and make one's choice, with the able and willing help of a senior assistant. Our most favoured firm happened to be R. & J. Beck, then flourishing in Mortimer Street, W.1, who had already provided

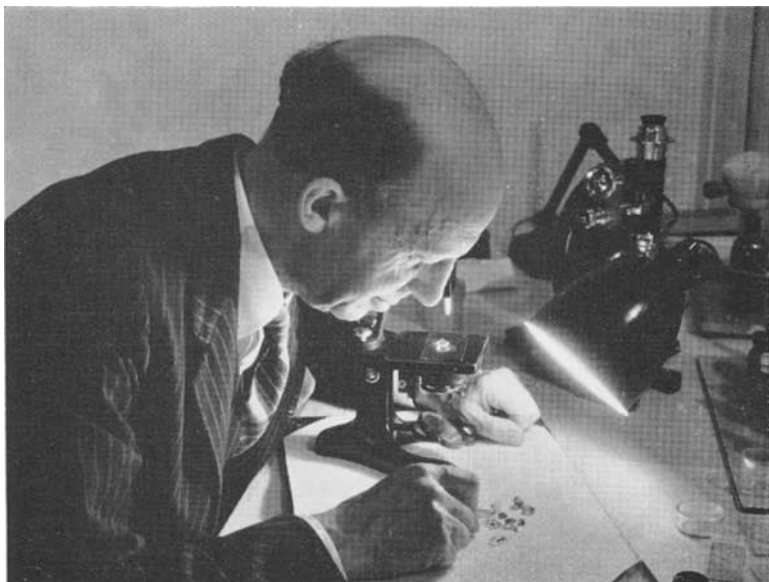

FIG. 1. B. W. Anderson sorting a parcel of stones. (Photo by courtesy of *The Times*.)

us with an excellent table spectrometer and several types of spectroscope. From them we now acquired four splendid “Greenough” type binocular microscopes with large square stages, inclined eyepieces and adjustable substage condensers. Three paired objectives, rapidly interchangeable, gave us the choice between  $25\times$ —the most generally useful—and higher magnifications. Special advantages of these instruments compared with monocular microscopes were the unreversed image (making the handling of small stones while under observation infinitely easier); the large working distance between objective and stage, enabling sizeable pieces of jewellery to be examined; stereoscopic vision; and the inclined eyepieces which made long sessions at the microscope bench possible without undue fatigue.

Even more important than choosing apparatus, and far more difficult, was the task of finding two gemmologists not only able but willing to tackle the arduous, skilled, and responsible work to be undertaken. Here I was fortunate indeed in being able to persuade Robert Webster, who had already made his mark as gemmologist, teacher, and author, to join us in the Laboratory—a step which

was mutually beneficial. And by a happy chance A. E. Farn, one of my former students who had recently been demobbed, came to see me at just the right moment in search of a job entailing more gemmology than he could expect with his old firm, the jewellers Jay, Richard Attenborough & Co. This completed a team which was before long to become a well-balanced and powerful force in gem-testing and research.

Robert Webster joined us in April 1946, and Alec Farn in May. These were relatively easy months, enabling the newcomers to some extent to play themselves in. The real crunch came in June of that year, when we all had to go through a baptism of fire since, in addition to having 6,126 stones to test, we had also to cope with 10,800 pearls, mostly taken from bunches. These were small and with drill-holes full of pearl-dust, so that much of Farn and Webster's time was taken up with cleaning these tiresome beads to enable Payne to make good progress on the endoscope.

To gemmologists accustomed to testing stones in ones and twos, or perhaps in some multi-stone jewel, to be faced with the problem of coping with parcels of a thousand or more very small rubies or sapphires was a formidable adventure. One realized, of course, that it was vitally important that no mistakes be made and that, so far as humanly possible, no stones be lost in the process. After toying with various ingenious ideas on how best to tackle the problem, a very simple system was evolved which proved (after some weeks of practice) to be both speedy and safe. Stripped photographic quarter-plates provided bases of convenient size to rest on the square microscope stages, and on these some fifty of the stones to be tested were spaced in line, and each stone examined in turn under  $25\times$  magnification, sliding the plate slowly across the stage by hand. Stones which were clearly genuine were left *in situ*; synthetics which revealed themselves at first glance were removed with the tongs and placed in a separate container, whilst those specimens which did not at once show their nature were pushed out of line and eventually examined carefully immersed in methylene iodide. At first the number of these "X" specimens (as we called them) was considerable, but as our expertise grew they became remarkably few. The stones in each consignment were carefully weighed at the outset, as this provided a more rapid and certain check on any stones lost than counting, though after each test was completed both natural and synthetic stones had of course to be

counted as well as weighed. Here again, experience in handling very small stones reduced the time spent in hunting for stray specimens, which at first had seemed an inevitable concluding chore with each parcel tested. When stones were missing, the operator's trouser-cuffs were the first focus for investigation, followed by the work-bench and finally the floor. This was of brown lino, against which small rubies did not readily show up. In serious cases the whole staff would be groping on the floor, lamp or torch in hand, examining the "concentrates" after sweeping a wide area with a soft broom.

In the course of viewing under the microscope so many thousands of Burma rubies (sapphires were in smaller demand) one grew to appreciate to the full the manifold beauty of their colour

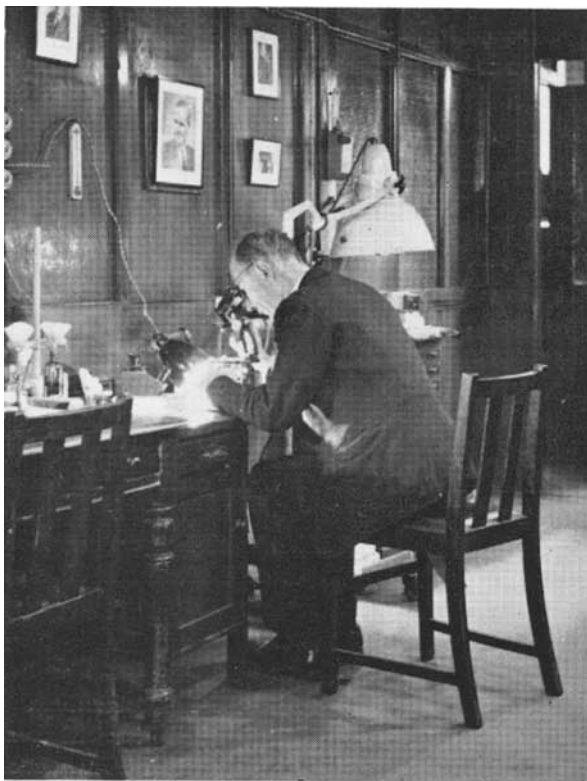

FIG. 2. C. J. Payne in the old lab. at 55 Hatton Garden.

and inclusions, and became extraordinarily perceptive of the smallest traces of "silk" or of the curious syrupy colour-breaks which we nick-named "treacle". As to synthetics: however free from bubbles they might be, one had the comforting knowledge that in the correct orientation and with lowered condenser or tilted mirror the curved striae would inevitably make their appearance. In each case, so distinctive were these features that there was absolutely no need for further testing. Only three or four times did a red spinel appear as an intruder, and these created no problem, since both their colour and inclusions were so distinct from those of ruby that each stood out like the proverbial sore thumb.

Usually a parcel of around a thousand stones would take one of us about a day and a half to complete, allowing for the inevitable interruptions to meet the needs of customers with short-term tests. Faster times were possible when a clear run could be achieved and when the stones concerned were rather larger than the fiddling little five or ten pointers which were our most frequent fodder. To quote one example from my notes of this period (I kept a record of every test), I was able to complete the examination of a parcel of 201 rubies containing six synthetics in a matter of 45 minutes.

In that year of 1946 we tested more than 104,000 stones, of which 100,000 were concentrated into the last seven months. Most of these were rubies, but there were a considerable number of sapphires too. One parcel consisted of 2,005 Kashmir stones, in which the 4500Å absorption band proved of great value as an additional test in those cases where a stone was exceptionally clean. In 1947 the stone total dropped to 40,000, and thereafter political factors altered trading conditions, and London lost for ever its supreme position as the world market-place for the highest class of precious stones. The annual figure eventually levelled off at around fifteen to twenty thousand, but these actually represented far more individual tests, and the majority of the stones examined were mounted, which was liable to make their inspection and identification much more awkward and time-consuming.

I have always regarded the number of reports issued by the Laboratory as the truest indicator of the amount of work done during a given year. Before the war, when Payne and I were without help of any kind, we issued 898 reports in our peak year of 1937. During the war the lowest ebb was in 1941, when I issued only 290 reports. But by 1944, though still on my own, the number





FIG. 3. C. J. Payne and Robert Webster discussing an x-ray report.  
(Photo by courtesy of Gordon McLeish & Associates Ltd.)

had increased to 782. In 1946, the big year for stones of which I have just been talking, the reports totalled 1,677, while the all-time record so far is held by the year 1970 when no fewer than 4,005 reports were written. Report numbers have been consecutive from the time the first was issued in 1925. At the present time the grand total stands near 90,000, so that I feel there is a fair chance that I may live to see the 100,000th written, and perhaps be allowed to append my signature!

A major reason for the increased use of the Laboratory was, of course, the advent of a succession of new types of synthetic stone. During the first forty years of the century, the field of man-made gemstones had hardly extended beyond corundums and spinels in a wide variety of colours. Then, after the war, beginning with Carroll Chatham's emeralds, factory-made gemstones made their appearance in rapid succession—a trend which has continued to the present day, so that even apparently inimitable products of nature such as opal are no longer safe from reproduction by the

scientist. Nor has it been only synthetic stones which have caused headaches for those who trade in gems: irradiated diamonds, treated opals, stained jade, impregnated turquoise, ingenious doublets, all tended, as they made their appearance, to make life difficult—in fact, not only difficult but quite impossible for the trade, were it not for the protection of an efficient testing Laboratory.

Another important and welcome factor which led to more work for the Laboratory was the increasing flow of tests from the retail jewellery trade through the National Association of Goldsmiths, by agreement with the London Chamber. A similar arrangement was later made with the British Jewellers Association.

Something more, perhaps, should be said about the new apparatus other than microscopes which we acquired soon after the war. Of prime importance was the new x-ray equipment designed by our friend C. G. Osment, who had already provided us (through his firm of General Radiological Ltd) with our previous two sets. The earlier models were intended purely for testing pearls by the sure but very slow process of x-ray diffraction—drilled pearls, of course, being dealt with much more rapidly by the endoscope. The new equipment gave us the choice of employing either diffraction or direct radiography, which before long was developed by Robert Webster into our standard method. More than this, the fluorescence of pearls and of gemstones under x-rays could now be closely and safely studied, and this proved to be of very great practical value. An aperiodic balance weighing to a tenth of a milligram helped the accuracy of our density determinations, and an Abbé-Pulfrich refractometer made possible refractive index readings to four places of decimals in the special cases where this was desirable, though for most purposes our standard Rayner and special spinel refractometers were perfectly adequate. For high readings we were lucky in having the unique diamond refractometer which Rayner had made for us in the 'thirties, the diamond surface of which remains unblemished to the present day.

A small electric furnace giving temperatures up to nearly 1000°C was found to be valuable for research and also enabled us to give reports on the purity of samples of diamond powder or grit, often found to be contaminated with silicon carbide, sand, iron filings, and a whole range of odd substances. A micrometer eye-piece enabled us also to report on average grain-size, where this was required.

The scope of our testing was indeed continually growing, our opinion being increasingly sought on carvings, snuff-bottles, etc., made from jade and other hardstones, turquoise, ivory and the like. Amber and its plastic imitations were other substances on which advice was frequently needed. Both Robert Webster and I gradually accumulated a collection of almost all gem materials and their substitutes, and these were of enormous value for comparison tests in the Laboratory and for teaching purposes. From his close friend, the late Harold Lee, who was an industrial chemist of exceptional skill, Webster assimilated the know-how for some very useful micro-chemical tests, and his specialized knowledge of ivory and bone, work on which had gained him a Research Diploma, was another useful asset.

As the Laboratory in the course of time settled down to a fairly steady routine, it became convenient for each one of us (though ready to tackle *any* of the work if necessary) to specialize to a certain extent, and this often saved argument as to who should do what. Thus, all the drilled pearls (except obvious cultured pearl necklaces) were passed to C. J. Payne, while partly drilled or undrilled pearls were Robert Webster's special province, using mainly direct radiography, at which he had acquired great skill. Stone-testing, unless it became excessive or entailed something quite out of the ordinary, was the province of Alec Farn, whom we all came to acknowledge as "the tops" when it came to finding the necessary evidence with lens or microscope to condemn a difficult synthetic. As for me, I saw to the administrative side, filled in with any necessary testing, and kept a record of every job we did. The tedious and time-consuming work of book-keeping was covered with great efficiency by Robert Webster. Ideally, of course, such chores, and others such as answering the door and telephone, should have been looked after by a purely clerical member of the staff, as they were matters which were continually bedevilling our concentration.

*The Move to 15 Hatton Garden*

Our premises on the second floor at 55 Hatton Garden were spacious, but by no means ideal. The dark-room, for instance, was a boarded-up cubby-hole some five feet square, two steps up on the way to the lavatory and wash-basin. Descending from this without due care the taller amongst us were apt to suffer a severe blow on the head as it met the lintel of the door. When our lease expired, the resultant move to the basement of 15 Hatton Garden had much

to commend it, not least being the fact that we were closer to the premises of our most frequent users. For many dealers a walk of fifty yards to have a stone checked seemed reasonable whereas a journey of three hundred yards to the far north end of the Garden was not. It should be said that in both situations we were fortunate in having neighbours who were not only friendly but useful. At 55, the Austen sisters were handy for restringing pearls on the floor below, the manufacturing jewellers Joseph & Pearce were on the ground floor, while Arco Electrical, skilled in electrical repairs, were in the basement. Again, at No. 15 we could have our eyes tested at Sharlands on the floor above, stones removed or replaced by Fryer on the first floor, while next door were Mathews Lapidaries under Bull Diamond, the best cutters in Hatton Garden.

The actual move, on a bitterly cold Saturday morning at the end of January, 1954, will be remembered by us all for its sheer discomfort. The gallimaufry of apparatus, books, furniture and accumulated junk of years past looked so unpromising that our hoped-for cleaner, after one look at it, threw in the sponge. And in the midst of this muddle we had to stand for hours with the window removed from its frame waiting for the arrival of our 2½ ton safe, which finally arrived at 2 p.m. breaking, as a final gesture, the heavy sleeper down which it was being slid into position. However, after a week or two's hard work, things began to look quite ship-shape. We had at last a properly equipped and spacious dark-room, with running water and shelves for all our chemicals, and there were a number of alcoves in the back rooms which proved ideal "stations" for our spectroscope set-up, for ultra-violet lamps, and so-on. Daylight admittedly was only available in the front room, but a combination of fluorescent strip and tungsten lighting, together with the white walls and ceilings made the place look bright and cheerful, while Webster's talent for assembling electrical points on to conveniently accessible panels was exploited fully, and we began to feel at home. The stairs leading from the ground floor to our dungeon were rather steep, but the sound of descending footsteps at least gave us ample warning of the approach of customers, postmen, or whatever. In the course of time we learned to recognize most of our most frequent visitors by their speed and style of descent, which varied from the rapid tumbling sound of our favourite pearl-merchant to the portentous tread of the two "Weights and Measures" officials whose haughty behaviour in checking the



FIG. 4. A. E. Farn weighing stones on an Oertling aperiodic balance. (Photo by courtesy of Gordon McLeish & Associates Ltd.)

accuracy of our meticulously maintained balance we found very difficult to take.

Unfortunately the comfort of our quarters was badly disturbed some years later when the building next door was demolished and rebuilt in the modern manner. After suffering for weeks the earth-shaking impact of giant digging machinery, clouds of penetrating dust, and obstructive scaffolding, our rooms were invaded one day by quantities of rubble which poured down our chimney. Eventually this had to be sealed off (the builders assured us), which deprived us of our main ventilation shaft. Such are the penalties of "progress", which continues, alas, to transform Hatton Garden from a street of history and character into an ordinary City road full of office blocks.

Looking back over the years and skimming through old records one can recall scores of amusing incidents and gemmologically interesting experiences with which I could entertain you if time allowed. Any worth-while discoveries or invention of new techniques were usually written up by one or other of us in the

*Gemmologist* or *Journal of Gemmology*; but there were a number of occurrences which naturally enough were too confidential or personal to be put on record at the time, as well as being of insufficient scientific importance. The three tests I am going to describe to you now are chosen as being good examples of cases where the sheer numbers involved constituted a challenge, and as examples of how much can be accomplished by unconventional methods, given expertise and ingenuity, where standard procedures would be far too time-consuming.

One of these cases concerned a parcel of some 5,000 industrial diamonds weighing 4,720 carats which had been purchased cheaply at 21/- per carat but which were rightly suspected of harbouring a certain number of "strangers". After preliminary inspection we decided that the highly characteristic appearance of the rough diamonds, even where their crystal form was not well developed, offered the most rapid means of carrying out a preliminary sorting, and moreover that this procedure was perfectly safe provided we submitted anything about which we had the slightest doubt to further tests. Payne and I accordingly set to work in turns, using a head loupe under the strong light from a desk lamp, putting on one side the undoubted diamonds. The remaining stones weighed some 200 carats, and on these we made use of the unique transparency to x-rays of diamond: in the final result 130 carats of non-diamonds were segregated. Fortunately for us the dealer was not interested in knowing the exact nature of these! Incidentally, x-ray transparency tests proved very useful in checking parcels of the once highly prized coke-like variety of industrial diamond known as carbonado. Not only their nature but the degree of impurity contained could be clearly checked by this method.

On another occasion a member had been asked to guarantee the authenticity of the small white zircons in which he traded, and asked for a parcel of 1,500 of these, cut as brilliants, and 600 baguettes to be checked. Here the spectroscope provided the quickest certain answer, the narrow 6535Å line and its weaker companion at 6590Å being picked up in each by a rapid survey in reflected light. The yellow glow of these stones under long-wave ultra-violet light was used as a double check. Unfortunately I became so interested in studying the bright-line rare-earth fluorescence spectrum of some of these stones that I kept them too long under the u.v. rays for their health, and found to my horror that they had assumed an unpleasant

brownish tinge. Luckily for me a spell on the hot-plate of our domestic Aga stove put things right, and I had the undeserved added pleasure, in the pitch-dark kitchen, of observing the thermoluminescence which persisted while the change-back in colour was proceeding.

The third large-scale challenge I want to mention concerned pearls and was important for its long-term effect on our testing methods. A consignment of mostly natural but old and low-quality drilled pearls contained in a small sack was dumped on us, with a request that they should be tested as cheaply as possible. There was no question here of testing them on the endoscope. Their drill-holes were so large that one could almost walk inside and look around, and being old pearls they showed the seasonal growth-layers and dark, conchiolin-rich centres very clearly in most cases, so that lens inspection was all that was necessary to prove their natural origin. We could not allow such an influx to interfere with our more urgent day-to-day testing, so Payne, Webster and myself formed the practice of taking turns to test batches of these ancient relics in our back room where there was a convenient baize-covered table. The whole job took several months to complete, and the final tally revealed that of the 89,739 pearls tested, 1,460 were cultured. This quite unusual "extra" task which we undertook in the winter of 1955/56 had an important influence on our pearl-testing methods. After 30 years of use and damage by blast during air-raids, our three endoscopes were patched-up relics of their former selves, and the replacement needles made for us by a friendly craftsman had not the brilliance of the original French-made products. It was thus natural that we were glad to take advantage of our now increased skill and confidence in testing by lens and reserve the endoscope for difficult cases only.

#### *Teaching and Publications*

In addition to our daily work in the Laboratory, Webster, Farn and myself were all doing evening teaching, first at Chelsea Polytechnic (the original home of these classes in gemmology to which all who knew it will look back in affection) and later at Northern Poly where the neighbourhood was far less salubrious. And the results of our experiences in the Laboratory were being shaped into numerous articles, published chiefly in the *Gemmologist*—that valuable monthly journal which covered the span 1931 to 1962—and in the *Journal of Gemmology*, brain-child of G. F. Andrews, which

first appeared in 1947. The most permanently useful of these papers were probably a series of twelve articles by Robert Webster giving a complete review of luminescent effects in gems under long and short-wave ultra-violet light and under x-rays, and 39 articles on the use of the spectroscope in gemmology, in which I gave a full account of the pioneer work which C. J. Payne and I had started way back in the early 'thirties.

Even for those people who take their gemmology seriously enough not only to read such articles as they appear, but keep bound copies of the relevant journals on their shelves, their content all too quickly becomes lost in the mists of time unless it is included in the more easily accessible form of a book. Fortunately this was done in a very thorough fashion by Robert Webster in his great book *Gems*, first published in 1962, of which the third edition is soon to appear. In its more limited field, my own book *Gem Testing*, now in its eighth edition, has made available the most useful fruits of our Laboratory experience throughout the years.

The lack of spare time in these twenty-five post-war years prohibited prolonged and leisurely research on the scale possible in the quiet 'thirties, but quite a respectable body of work was done in connexion with new gem minerals, as described in detail in my last talk, and as a matter of urgency we had to learn to cope with each new synthetic product and each new "treated" or irradiated gemstone as it appeared. In this important matter of keeping abreast of new developments we were helped considerably by being provided with samples of the stones concerned by certain public-spirited firms, and by a valuable and close liaison with Robert Crowningshield and Richard Liddicoat, of the Gem Testing Laboratories in New York and Los Angeles, who so often were ahead of the rest of the world in being able to handle the latest synthetic or illegitimately "improved" gemstones.

Before I end, I should like to mention two valuable additions to the gem-testing armoury which we developed in the Laboratory, each of which is easy and inexpensive to apply. One was the use of a copper sulphate solution to act as a filter in front of the power light employed in connexion with the spectroscope, which not only made observation of absorption bands in the blue and violet parts of the spectrum far more feasible but, in conjunction with a suitable red or orange complementary filter, provided a powerful means of stimulating and viewing fluorescence. It would be a mistake to



regard this "crossed filter" technique as merely a sort of "poor man's ultra-violet", since the effects observed can often not be seen under any other conditions of stimulation.

The other concerns new and effective immersion techniques which have very wide applications. It has, of course, long been recognized that the degree of "relief" shown by a stone immersed in a liquid or of an inclusion imbedded in a crystal is greater for substances having a refractive index markedly different from that of the imbedding medium, and the so-called "Becke line" effect which enables the mineralogist to determine under the microscope which of two media in optical contact has the higher refractive index is well known to students of gemmology, if only by name. When it comes to cut gemstones immersed in liquid, the movement of the bright Becke line at the edge of the stone is difficult to see and still more difficult to interpret with absolute certainty. In 1951, a laboratory experiment in which I used a contact photograph of a blue synthetic spinel immersed in monobromonaphthalene to record the unusual curved colour-bands seen in the stone led to further experiments in immersion contact photography of gemstones which yielded spectacular pictures not only demonstrating beyond peradventure whether the stones involved had higher or lower refractive indices than the fluid in which they were immersed, but also by how much lower or higher. It also provided a very simple and rapid photographic record of the size, outline, facet-pattern and included features of a gemstone (including curved striae in synthetic corundums) all without benefit of a camera. Some years earlier, we had found both synthetic rubies and synthetic emeralds to be notably more transparent in the ultra-violet region than their natural counterparts, and a suggestion by Norman Day enabled immersion contact photography to display this difference in the simplest possible manner. One has to realize, of course, that testing methods involving even the simplest forms of photography are hardly practical politics for the majority of jeweller-gemmologists, and I was happy to devise a very simple set-up which showed immersion contrast effects in all their spectacular beauty with the aid of only a piece of ground-glass and a pocket mirror. These techniques are now described in several text-books, but I still feel that their simplicity, beauty and power are not sufficiently recognized.

Owing to the Trade Descriptions Act of 1968, which is excellent in principle but sometimes a nuisance in practice when enforced in

too heavy-handed a manner by officials who don't sufficiently understand the trade, the Laboratory had latterly to face a great increase in awkward little tests to decide such things as the exact nature of the subsidiary stones (either diamonds or representing diamonds) mounted on the shoulders or as surrounds of stones set as rings, etc. Doing this fiddling if necessary work made us very conscious of the filthy state of the backs of stones in their settings which obtains in jewellery if it is frequently worn. A small pot of water containing a mild liquid detergent, and a small soft tooth-brush became an essential feature of the work-bench. It was found well worth while to spend time in cleaning a jewel thoroughly before attempting to examine it under the microscope. While one might think it a good thing to advise the owners of jewellery to have it cleaned periodically, as this so greatly enhances its appearance, particularly where diamonds are concerned, there may be considerable risks when the now fashionable ultra-sonic cleaners are employed. Deleterious effects have been reported in the case of blue zoisite (tanzanite), which may develop flaws under this ordeal. And emeralds, which unfortunately nowadays so often have their appearance up-graded by soaking in oil to diminish the effect of any surface-reaching flaws, will emerge with the oil leached out of them and looking very much the worse.

In my three talks on London's gem-testing laboratory, I hope I have been able to convince you of the absolute necessity for the health, reputation and prosperity of the trade that such a reliable, independent, specialized laboratory should be maintained in this country, and indeed in all countries which trade in gems. In the course of my narrative I may not have made it sufficiently clear how much of the success of the Lab. has been due to the work of my three gifted and loyal colleagues. Their talents, I am sure, could have earned them higher material rewards, but certainly not a more interesting life, gemmologically speaking.

Our Laboratory, I am glad to say, continues to flourish in its new quarters in 36 Greville Street, E.C.1, which is only a stone's throw from the hole in the ground which at the moment marks our former home. It is now in the experienced hands of Alec Farn, who is assisted by three promising young gemmologists. Though the old hands have had to leave the Laboratory, they remain in the wings, ready and available should help or advice be needed.

# INCLUSIONS IN GEM ALMANDINE FROM IDAHO AND NEW YORK

By *PETE J. DUNN, M.A., F.G.A.*

Department of Mineral Sciences, Smithsonian Institution, Washington, D.C. 20560, U.S.A.

## INTRODUCTION

Gem almandine has been mined since the turn of the century at the Barton mine, North Creek, New York, and at Emerald Creek, Clarkia, Idaho. These two localities have produced prodigious amounts of almandine which, although only a small percentage thereof is faceting quality, has been widely disseminated and is now frequently encountered as cut gems. The present study was initiated to determine the nature of the abundant inclusions in these two almandines.

## METHODS OF INVESTIGATION

The almandines and inclusions were x-rayed utilizing a Gandolfi 114.6 mm powder camera and  $\text{CuK}\alpha$  nickel-filtered radiation. The almandines were ground and polished until the inclusion to be studied was exposed and the inclusion scratched with a sharply pointed diamond chip. The resulting powder was gathered on the tip of a glass capillary and exposed in the Gandolfi camera. The Gandolfi powder camera is ideally suited to the x-ray study of inclusions because it employs two axes of simultaneous rotation, which eliminate preferred orientation problems, and because it affords accurate powder data from a very minute sample. The Gandolfi camera can also give powder data from a single crystal with careful manipulation.

Density determinations were made on a Berman microbalance with toluene as the liquid and employing a temperature correction factor. Optical determinations were made in sodium light using a polarizing microscope and the Rayner Dialdex refractometer.

The almandines and the inclusions were chemically analysed on an ARL electron microprobe, using an operating voltage of 15KV and a sample current of 0.15 Ma. The standards used were NMNH microprobe standards of high reliability. The intensities were corrected for absorption, fluorescence, backscatter and stopping power with the ABFAN computer programme of The Geophysical Laboratory, Washington, D.C. The analyses are presented in Tables 1, 2 and 3.

TABLE I  
ALMANDINE, LABRADORITE AND ILMENITE ANALYSES

	Gore Mtn, N.Y. Almandine #90518	Gore Mtn, N.Y. Almandine (Miers 1926)	Emerald Creek, Idaho Almandine #128192	Labradorite in #90518	Ilmenite in #128192
SiO <sub>2</sub>	40.1	40.24	37.9	55.47	
TiO <sub>2</sub>	tr		tr	0.00	52.0
Al <sub>2</sub> O <sub>3</sub>	22.8	20.66	21.6	28.34	
Cr <sub>2</sub> O <sub>3</sub>	tr		tr		
Fe <sub>2</sub> O <sub>3</sub>	25.0	4.65	36.9	0.0	46.7
FeO**	9.8	18.58	4.4	0.0	.56
MgO	0.4	11.18	0.6	0.0	.21
MnO	4.1	.25	.4	10.80	
CaO	0.0	5.3	tr	5.39	
Na <sub>2</sub> O	tr		tr	0.0	
K <sub>2</sub> O					
Total	102.2	100.26	101.8	100.00*	99.53

\*Normalized to 100%.

\*\*All iron analyses of this study expressed as FeO.

Specimen numbers are from the National Museum of Natural History, Smithsonian Institution collections.

## NEW YORK ALMANDINE

The Barton mine (formerly known as the Rogers mine) on Gore mountain, North Creek, New York, is a source of gem-quality almandine. The Gore mountain garnet is mined for use as an abrasive. Crystals from this mine sometimes attain a diameter of 60 cm. The garnet is intimately associated with hornblende, hypersthene and plagioclase. The genesis of the deposit has been studied by Miller (1912, 1938) and by Shaub (1949). The garnet has a pronounced parting, parallel to {110}, yielding rectangular fragments well suited to emerald and oval cuts. Pyrite is frequently formed on the parting planes and was noted by Shaub (1949).

The Gore mountain almandine is deep red in colour, has a refractive index of  $n_D = 1.764$  and a specific gravity of 3.84. The characteristic almandine absorption spectrum was observed.

The analysis of this almandine is presented in Table 1. The analysis of Miers (1926) is also included to demonstrate the compositional variance of the material at this locality. The unit cell edge of this garnet is 11.54 Å, in good agreement with the observed physical and optical properties and the composition. The analysis of this study indicates that this garnet is comprised of 58% of the almandine component.

Solid inclusions are common in this material and are dominantly pyrrhotite, apatite, plagioclase, and chalcopyrite. All inclusions were initially identified by x-ray diffraction.

*PYRRHOTITE* is the most abundant inclusion and occurs as discrete, spherical grains, occasionally discoid, which are usually rather randomly distributed in the host garnet. The maximum size of these pyrrhotite grains in gem-grade material is about 0.2 mm and most are considerably smaller. In darkfield illumination the pyrrhotite appears as opaque blebs with red haloes due to reflection of light from the pyrrhotite. The pyrrhotite grains sometimes occur in swarms. Under very

TABLE II  
PYRRHOTITE ANALYSIS

Fe	59.87
S	38.09
Ni	.61
Co	.12
	<hr/>
	98.69

high magnification (286 ×) the pyrrhotite-garnet contact is seen to be very rough and this is likely responsible for the tendency of these grains to adhere tightly to the garnet and not pop out when exposed in the cutting and polishing of the gem. An analysis of this pyrrhotite is presented in Table 2.

*CHALCOPYRITE* occurs as very small crystals, usually attached to pyrrhotite grains and is quite uncommon. This mineral is not distinguished from pyrrhotite in the usual darkfield illumination.

*PLAGIOCLASE* occurs as anhedral colourless blebs ( $\approx 0.1$  mm in size). The plagioclase is usually arranged in a three-dimensional array of very tiny micro-crystals surrounding pyrrhotite grains. Some pyrrhotite grains are completely enveloped by plagioclase and Figure 1 shows a pyrrhotite grain enveloped by plagioclase. This enveloping of pyrrhotite by plagioclase causes the pyrrhotite to appear blurred. This plagioclase has a composition of An 50 (Table 1) and is thus labradorite. No compositional zoning was observed.

*APATITE* is abundant as an inclusion and forms resorbed hexagonal crystals which are readily recognizable by their obvious hexagonal cross section. The crystals are colourless and usually isolated (Fig. 2). Apatite is more abundant in the lower quality almandine which has many acicular canals. Although the apatite has a deficiency of chlorine (Table 3), there is insufficient fluorine to classify it as a fluorapatite. Hydroxyl could not be determined due to the limitations of the microprobe and the paucity of material, but it is assumed from the fluorine and chlorine content, that this apatite is probably a fluorine-rich hydroxylapatite.

TABLE III  
APATITE ANALYSES

	From Gore Mtn Almandine (#90518)	From Emerald Creek Almandine (#128192)
MnO	0.20	0.19
CaO	55.39	54.61
P <sub>2</sub> O <sub>5</sub>	42.79	42.68
F	1.12	2.17
Cl	.29	.21
Ce <sub>2</sub> O <sub>3</sub>	.05	.04
Total	99.84	99.90

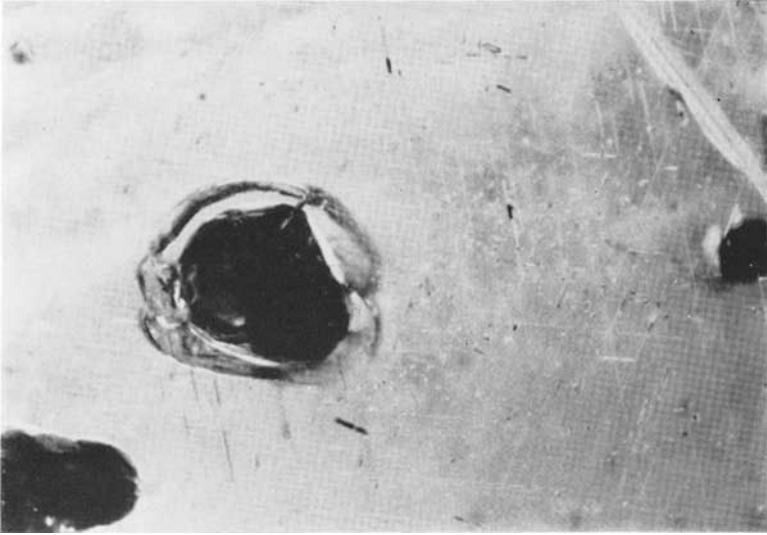

FIG. 1. Pyrrhotite bleb enveloped by labradorite. (60 ×)

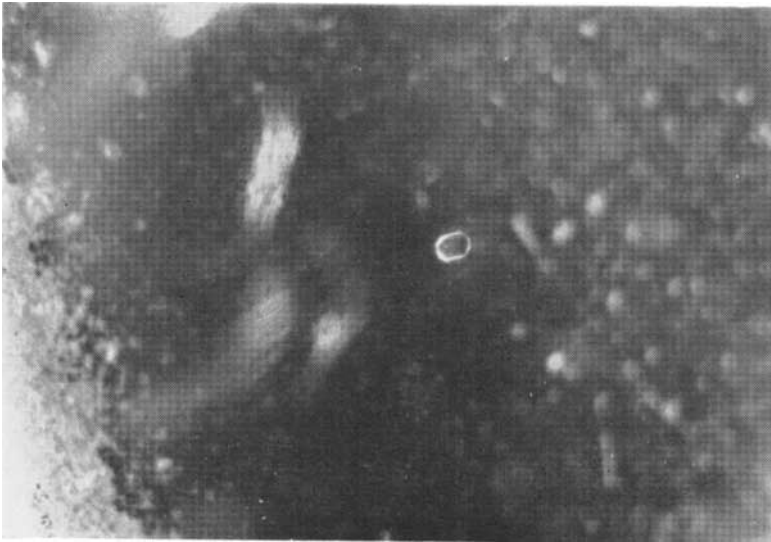

FIG. 2. Isolated apatite crystal in New York almandine. (70 ×)

*ACICULAR CAVITIES* are observed in this almandine but are too small to permit the determination of their contents. The majority of the cavities appear to be hollow, elongated 10 : 1 and, under very high magnification ( $400\times$ ), it can be observed that some unidentified opaque crystals occupy part of the cavities. These cavities are arranged in a three dimensional pattern suggesting they are parallel to  $\{110\}$ . Pyrrhotite grains are also included within the labradorite and apatite. Hence, pyrrhotite appears to have been the first of the inclusions to form.

#### IDAHO ALMANDINE

Gem almandine from Emerald Creek, Idaho, is best known as the opaque asteriated material from which very nice star-stones are cut. These star garnets grace many gem collections, public and private. Less well known, but equally interesting, is the clear almandine from the same locality, which is of faceting quality. The material examined in this study is from the east fork of Emerald Creek, Clarkia Ranger district, in St Joe National Forest, between Clarkia and Fernwood, Idaho. It was collected in the summer of 1971 by Donald G. Wyman and Leo C. Vaught, two noted and extremely capable New England mineral collectors and friends of the author. It is obtained as water-worn subhedral crystals in alluvium.

The Emerald Creek almandine is medium pinkish-violet in colour, has a refractive index of  $n_D = 1.808$  and a specific gravity of 4.07. The specific gravity increases to 4.11 in material with a moderate amount of included ilmenite and to 4.16 when opaque due to abundant ilmenite. The characteristic almandine absorption spectrum was observed.

The analysis of this garnet is presented in Table 1 and shows it to be almandine. The unit cell edge of this almandine is 11.52 Å and is in good agreement with the composition and observed properties. The analysis of this garnet indicates it is comprised of 85% of the almandine component and 15% of the pyrope component.

Inclusions of fluorapatite and ilmenite are abundant in the Emerald Creek almandine.



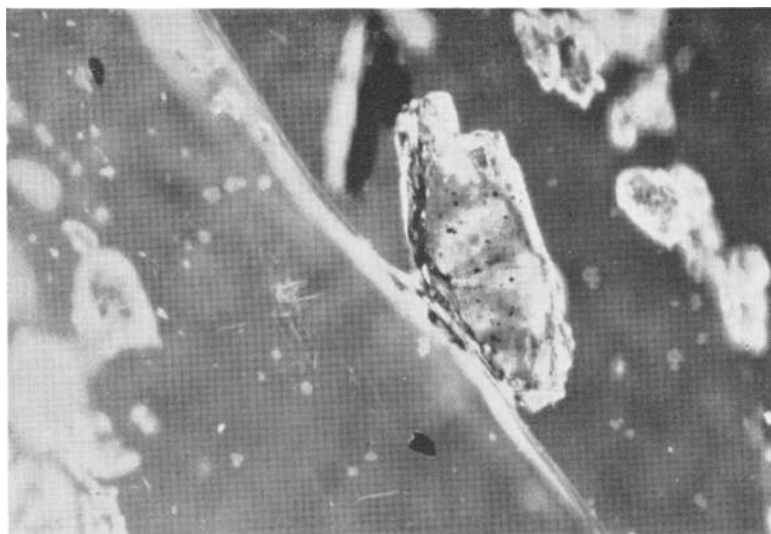

FIG. 3. Blocky fluorapatite in Emerald Creek almandine showing ilmenite included in fluorapatite. (30 ×)

*FLUORAPATITE* occurs in two distinct habits, both habits frequently seen in the same gemstone.

*a*—as parallel swarms of minute ( $<0.1$  mm) highly resorbed hexagonal crystals which resemble colourless cylinders as the resorption of crystal edges is severe.

*b*—as large (0.2 to 1.0 mm) irregular blocky blebs which frequently enclose ilmenite (Fig. 3). These blebs have noticeable pleochroism.

Separate analyses of these two fluorapatites are identical. The analysis is given in Table 3.

*ILMENITE* occurs as distinct, euhedral crystals, tabular in habit (Fig. 4). They are frequently concentrated in swarms with a galactic appearance and are randomly oriented within the swarms. Ilmenite crystals are also observed as inclusions within the large, blocky fluorapatite crystal inclusions. It is obvious that ilmenite was the first included mineral to form and was followed in the formation sequence by apatite. The analysis of this ilmenite is presented in Table 1.

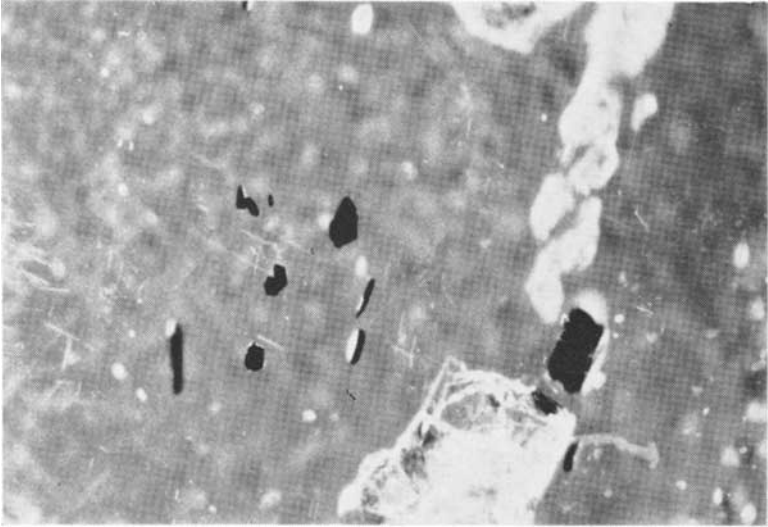

FIG. 4. Ilmenite and fluorapatite in Emerald Creek almandine. (35 ×)

The author is indebted to Mr Richard Johnson for the painstaking preparation of microprobe samples of the gems in this study. His contribution to the success of this study was invaluable. The author is also indebted to Mr John S. White, Jr, for proof-reading and suggestions for improvement in format.

#### SELECTED REFERENCES

- Agee L. M. (1965). *Asterism in garnet*. Lapidary Journal, **19**, 910.  
Miers, W. M. (1926). *The Mineralogy of some commercial garnets*. American Journal of Science, Ser. 5, **12**, 115-118.  
Miller, W. J. (1912). *The garnet deposits of Warren County, New York*. Econ. Geol., **7**, 493-501.  
Miller, W. J. (1938). *Garnets of certain Adirondack garnet deposits*. Am. Mineral., **23**, 115-118.  
Shaub, B. M. (1949). *Paragenesis of the garnet and associated minerals of the Barton mine near North Creek New York*. Am. Mineral., **34**, 573-582.

## REPORT ON A NEW ELECTRONIC REFRACTOMETER

*By* ROBERT WEBSTER, F.G.A.

WITH the advent of so many new synthetic (man-made) stones which are now used as simulants of diamond, the news that a new refractometer working with electronic devices would read refractive indices up to 2.7, seemed a welcome advance. The writer has had the privilege to examine one of these instruments, which are made by Sarasota Instruments Inc., of Sarasota, Florida, U.S.A.

The instrument consists of a metal box 9 inches wide,  $7\frac{1}{2}$  inches deep and 8 inches high overall. Finished in mottled grey enamel, the instrument weighs about 4 lb. On the flat top is a circular black plastic examination disc, which can be covered by a black plastic cup to provide a dust cover and a light trap when testing stones. The examination disc has a raised "nipple", at the centre of which is a small hole over which the stone to be tested is placed.

On the inclined top front of the instrument is mounted a meter marked in refractive indices and divided in the range 1.40 to 1.80 into divisions of 0.02, and in the higher range from 1.80 to 2.7 the divisions are 0.05. On the left of the meter panel is a push-button to activate the electronic system, while below the meter there is an adjusting screw to allow the meter to be calibrated with stones of known refractive index.

At the back of the case there is a removable half panel which when unscrewed and removed has, internally, the clip for holding the 1.5 volt alkali dry cell which supplies the necessary electric current. Figure 1 shows a picture of the "Gemeter", as the instrument has been named.

The literature sent with the instrument is careful to state that the facet of the stone to be tested must be scrupulously clean and not less than  $\frac{1}{8}$ th of an inch across. The facet, too, must be flat and well polished and should be carefully centred on the examination disc which, like the stone, must be dust free. Other operating instructions are given, as well as the means to calibrate the Gemeter. It is also suggested that several readings be taken and the mean of these readings taken for the final result.

A further clip of eight pages tells much about bi-refringence, although the Gemeter will not measure this constant. The write-

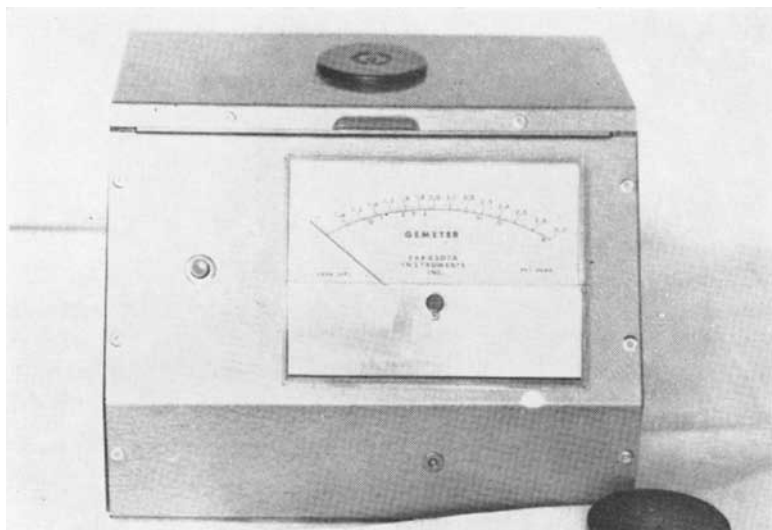

FIG. 1. The Gemeter (Top of plastic cup to cover examination disc is in partial view at lower right hand of picture).

up in these pages is largely inaccurate and leaves much to be desired. Certain facts of interest are given and these give food for thought. The makers have found that the Gemeter shows that the Y.A.G. stones seem to fall into two common values at approximately 1.82 and 1.87, and that the value for strontium titanate is 2.3 and not 2.4 as given in gem literature. These papers conclude with two sheets of graphs showing the refractive indices of stones. The system used for these graphs is that used by Karl Chudoba for the density of ornamental stones<sup>(1)</sup> and also currently used in *Edelsteinkundliches Handbuch* written by Chudoba and Gübelin<sup>(2)</sup>. No information whatsoever is given on the principle upon which the instrument works.

Before any estimation is made of the performance of the Gemeter it may be as well to discuss what the writer feels may be the principle upon which the instrument works, using for the assessment the facts elucidated by experiment.

Bearing in mind the various techniques which have been, and are, used to obtain the refractive index of transparent materials, it seems that none fit the features of the Gemeter. One has, therefore, to consider some technique which has hitherto been scarcely men-

tioned in gem literature. One of these, and in the writer's view the most likely, is by measuring the reflecting power of the stone to a light ray at normal (perpendicular) incidence. This may well be the answer.

Anderson<sup>(3)</sup> mentions that the proportion of reflected light to refracted light in transparent substances increases with the refractive index of the substance. However Anderson does not make any suggestion that the effect could be used to measure the refractive index of a stone.\* From the above reference to Anderson's note it may be inferred that a source of visible light would be needed. No visible light source could be found in the Gemeter, either by visible observation or by a photoelectric cell placed against the examination disc; and nor, to clear up any other possibilities, was it found to affect a compass needle.

Infra-red "light" is said to obey the same laws as ordinary visible light and this could conceivably supply an answer to the problem of how the Gemeter operates. For normal incidence the reflectance, denoted as  $r$  (the reflectance being the ratio of the reflected to the incident intensity) of a transmitting material is determined by the expression

$$r = \left( \frac{n - 1}{n + 1} \right)^2$$

where  $n$  is the index of refraction, and this formula is true both for visible and for infra-red light. It has been pointed out by Vaško<sup>(4)</sup> that reflectance of a material depends *to a great extent*, but not wholly, on its refractive index, and he further states that these values are only true for optically flat surfaces and any roughness of the surface will reduce the percentage of reflection.

At the present time it seems far from impossible for infra-red radiations to be so used, as currently small electronic devices are made both to produce and to detect infra-red rays. To probe this notion further, the wiring inside the Gemeter was examined and

\*Following a similar statement by Mr Anderson to a meeting in Salisbury early in 1958, the late L. C. Trumper, B.Sc., F.G.A., constructed a "differential reflectometer", designed to enable the refractive indices of gemstones up to 3.00 to be read off a calibrated dial and operating with white light from a 4.5 volt miniature bulb, and in 1959 was awarded a Research Diploma for his thesis on the measurement of refractive index by reflection: and according to an article by Roy Wilkins in the *Lapidary Journal*, 1972, 26, 432-434 (abstracted in *J.Gemm.*, 1973, XIII, 6, 232), a prototype instrument for determining refractive index by measuring reflectivity with a photocell and amplifier was made by R. H. Long in Oregon, U.S.A., but few constructional details were given.—Ed.

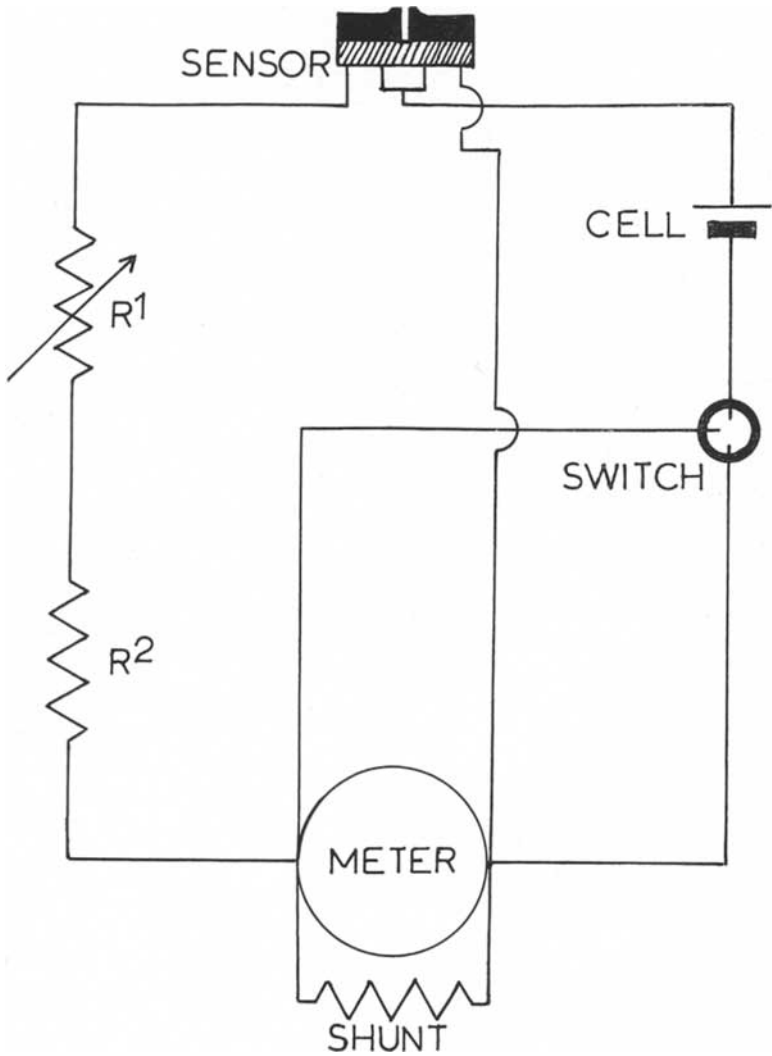

FIG. 2. Circuit drawing of the Gemeter wiring. ( $R^1$  is an adjustable resistance used to calibrate the meter.  $R^2$  is a fixed balancing resistance).

a circuit diagram prepared (Figure 2). This seems to show a balanced circuit in which any change in resistance would show on a suitable meter. There are semi-conductors of very small size which will alter an electrical resistance when irradiated with either visible light or infra-red radiations.

To test this idea further, the bulb of a finely graduated mercury thermometer was clamped over the hole in the examination disc and a rise of temperature at the rate of approximately  $0.15^{\circ}\text{C}$  per minute was seen to occur. It is by reason of these observations and other features displayed during the actual operation of the machine that the writer feels that infra-red reflectance is the method used in the Gemeter.

Some 300 faceted gemstones of various species and refractive indices, from fluorite (1.43) to rutile (2.90), were examined on the Gemeter, and records were made of some 1,000 observations. The stones used were "run of the mill" stones from commercial suppliers and stones from the writer's personal collection. No selection was made as to the style of cutting or the perfection of the polish, this being in keeping with the view that the instrument is to be marketed for the use of jewellers and not trained gemmologists.

The values registered on the Gemeter were found to be nearly always much lower than the known refractive index of the species, and in only a few species were indices recorded anywhere near what they should have been. Quartz and beryl and, of course, diamond, which usually has such a superb polish and is normally used for calibration, were exceptions. In no case could the birefringence be estimated even by turning those stones which had known optical directions. Stones with large double refraction, such as peridot, zircon and rutile, failed to display any marked differences in readings which could be ascribed to double refraction.

Two frustrating aspects were that the instrument would not always "repeat" itself even when the position of the stone had not been altered on the examination disc, and, secondly, that any different degree, or angle, of pressure on the activating button resulted in different readings being obtained. There is some evidence, too, that the electronic system may suffer from "fatigue", from which it may later recover. Although the instruction sheets suggest that temperature may cause a difference in readings—the instruments are said to be set for  $72^{\circ}\text{F}$ , which may be a useful value for Florida, but for England  $60^{\circ}\text{F}$  to  $65^{\circ}\text{F}$  would be a better value—

experiments have shown that there is little difference with temperature changes.

The makers claim that the refractive index of strontium titanate is, on the Gemeter, 2.3 and not 2.4 as given in gem literature. The values found on the few stones of this type tested were nearer to 2.2 than 2.3 in most cases. There seems to be some justification for the makers suggesting two values for Y.A.G. stones. Personal but not extensive observations of the behaviour of yttrium aluminate on the Gemeter seem to show that there may be something in this notion.

Most of the paste stones examined on the Gemeter seemed to give a reading about 1.50, even with pastes known to have an index of refraction of 1.65. Certain iridescent pastes, which have a true refractive index of 1.57, gave readings of 2.1 to 2.3, while another stone with similar characters gave a reading of only 1.40.

Much more startling was the result obtained on a faceted Burma red spinel, which had a true refractive index of 1.714 but gave on the Gemeter readings, of which many were taken, of anything between 2.5 and 2.7. Another Burma crystal gave a reading of 1.80 from an unpolished natural crystal face.

Large awkward-shaped stones, such as pendeloques and long trap-cut stones, do not balance well on the raised "nipple" of the examination disc, nor could mounted jewellery be easily accommodated; such stones and jewellery tend to fall over after the plastic cup is placed over them, with the consequence that one gets false readings or none at all.

To sum up: although at first sight the instrument appears to have some potential, experiments have shown that this is not as hoped. Up to a reading of 1.80 this electronic instrument cannot match the standard refractometers which operate on the projection of the shadow edge of the critical angle on to a scale or screen as in the Dialdex instrument. These jewellers' refractometers are far more accurate and do allow measurement of the bi-refringence. Over a refractive index of 1.80 there seemed more likelihood of a break-through, but as far as the instrument examined is concerned its seeming inaccuracies would make it dangerous to use except in the hands of an expert who could detect irregularities.

On a more constructive note, the writer might say that, mechanically, the examination disc would be more effective if the surface had been plane and had no raised "nipple". A simple hole



at the centre of a flat disc engraved with concentric circles as an aid to centering would be more effective. Electrically, the push-button switch seems to be somewhat faulty; it could be replaced with something more robust and could with advantage be placed on the top of the instrument, which would allow a more even distribution of pressure on the button. It might be more advantageous to confine the Gemeter to the ranges of 1.80 to 2.70 coupled with improvements to its performance.

What are the most important factors which, if the operation of the instrument is, as surmised, the reflectance of infra-red light, lead to the inaccuracies in such an instrument? Firstly, the measurement of the reflecting power of a transparent medium depends upon the reflecting surface being optically flat, and, except perhaps for well polished diamonds, this is not so with the normal polish given to gemstones, which therefore show "irregular reflections", producing a "scattered" type of reflection all of which does not reach the sensor, and hence a lower reading is shown on the meter. Secondly, not enough "homework" appears to have been done on the characteristics of gem materials under infra-red radiations.

It might be suggested that some of the irregularities in the meter readings shown by the Gemeter may be due to absorption of certain wavelengths of the incident infra-red beam, and this could well account for the lowering of the value of strontium titanate as shown on a "reflectance" instrument, and also some other "freak" low results. The reason for the higher readings, and in particular the anomalous effect of the Burma red spinel, is less easily explained. However, one might suggest that it could be due to a "fluorescent" effect in the infra-red producing a "characteristic" emission. A consideration of the effects of infra-red radiation on gem materials requires much further study and such an investigation may well be profitable, and, if the Gemeter does work on the principle outlined, further work may well iron out some of the faults.

In fairness it must be pointed out that the instrument examined had travelled some 4,000 miles and could conceivably have suffered some "shake-up" which could have impaired its working conditions, although no observable damage was noticed. The writer has

now been informed that a new model is being marketed which is said to "iron-out" some of the faults mentioned above. This new model has not as yet been evaluated.

#### REFERENCES

1. Chudoba, K. *Identification of translucent and opaque stones by density and colour*. *Gemmologist*, (1936), VI (64), 87-89.
2. Chudoba, K. & Gübelin, E. *Edelsteinkundliches Handbuch*. 3rd Edn. Stollfuss, Bonn, pp. 397-398.
3. Anderson, B. W. *Gemtesting*. 8th Edn. (1971) Butterworths, London, p. 353.
4. Vaško, A. trans. Allen, P. S. *Infra-red Radiation*. (1968) Iliffe Books Ltd. pp. 116-117.

---

## STAINED WALRUS IVORY\*

By E. A. JOBBINS, B.Sc., F.G.A. and Miss P. M. STATHAM, B.Sc., F.G.A.

THE exhibition "Ivory Carvings in Early Medieval Sculpture" mounted at the Victoria and Albert Museum, London, during May-July 1974, showed a number of beautiful and remarkably preserved carvings attributed to walrus ivory. They were produced during the period 700-1200 A.D. and reminded the authors that this material is little known in this country except for a few experts on medieval sculpture. Carvings in walrus ivory by Eskimo artists, mostly simple in form, have been reported from Scandinavia, Canada and other countries bordering the Arctic.

Some time ago a spinach-green necklace was submitted for examination with the comment that it had been offered to the enquirer as jade, which it clearly was not. Subsequent examination showed it to be fashioned from *walrus ivory*. Initial examination with a hand lens showed a generally nodular structure with many small cavities. The distribution of the colouring was very uneven and suggested that the beads had been dyed. Scrapings immersed in oil showed a generally fibrous appearance with tabby extinction, low birefringence and a mean refractive index just above 1.55. The beads were sectile with a hardness between 2 and 3 on Mohs' scale. The specific gravity was 1.99. Minute parings blackened on heating with a smell of burning protein—this virtually confirmed

\*Published by permission of the Director, Institute of Geological Sciences, London.

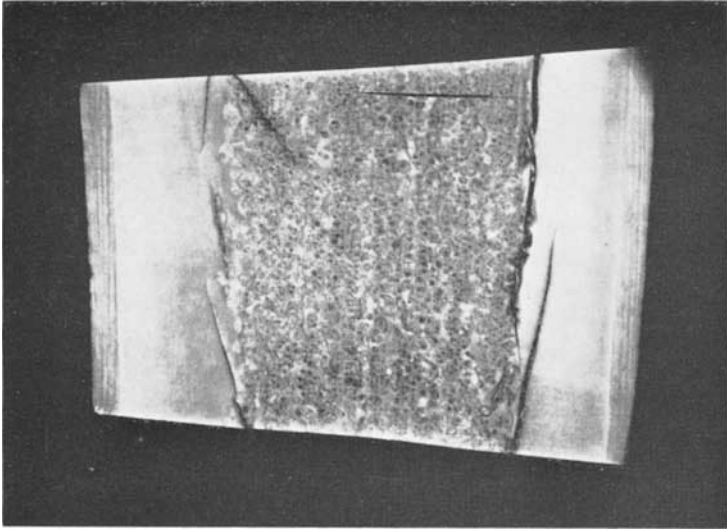

FIG. 1. Ivory: longitudinal section through walrus tooth. Magnification  $\times 2$ . Photo No. MN 18426.

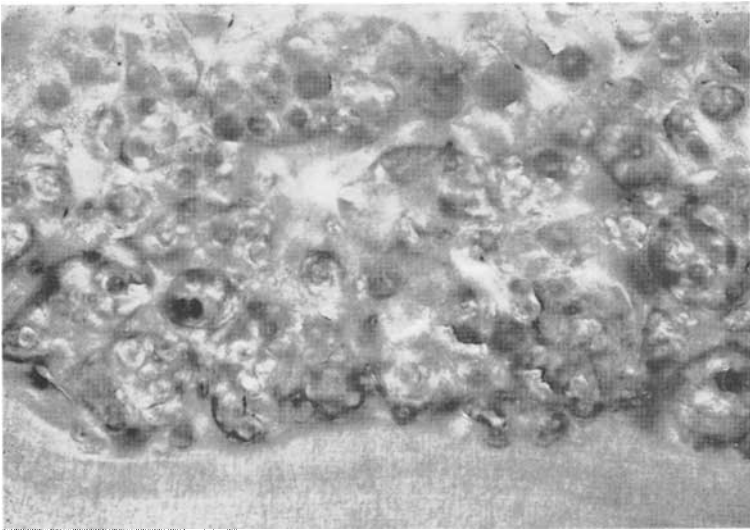

FIG. 2. Ivory: longitudinal section of walrus tooth showing finer outer and coarse inner parts. Magnification  $\times 12$ . Photo No. MN 18424.

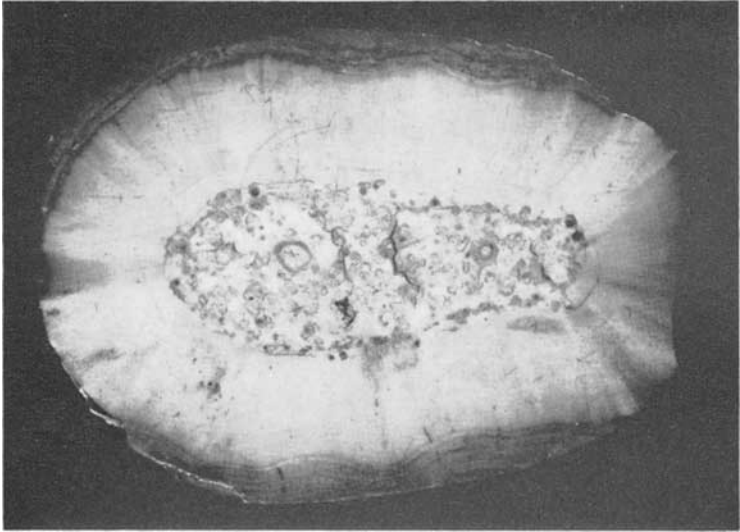

FIG. 3. Ivory: cross-section of walrus tooth showing fine outer and coarse inner parts. Magnification  $\times 3$ . Photo No. MN 18425.

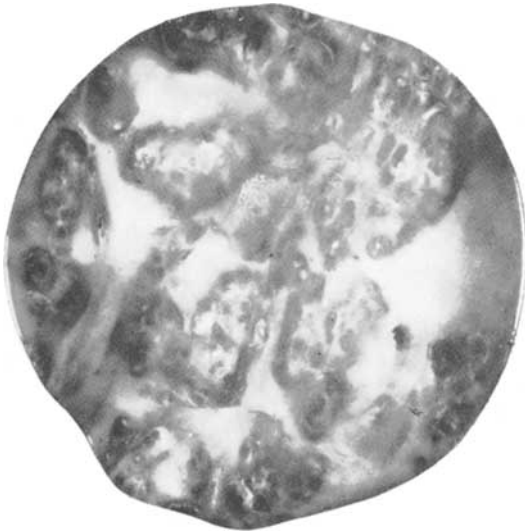

FIG. 4. Stained Ivory bead: polished section showing nodules and the darkening due to surface staining. Magnification  $\times 12$ . Photo No. MN 18460.

an organic origin. Microchemical tests showed the phosphate radical, and spectrographic analysis showed major calcium (Ca) with minor magnesium (Mg) and copper (Cu). The presence of calcium and phosphate together with the smell on heating and the Cu suggested teeth or bones which had been stained green by a copper salt.

By courtesy of officers of the Zoology Dept at the British Museum (Natural History) the beads were then compared with the more unusual forms of ivory and were identified as being fashioned from walrus teeth. Walrus teeth are enlarged canines from the upper jaw of the animal and are said to reach two or even three feet in length. In cross section the teeth may be broadly oval or circular but often take a deformed "figure of eight" shape. The outer part of the tooth is fine-textured and may show a concentric graining, but the inner "core" is coarser with abundant nodules or "whorls". These structures differ markedly from those in elephant ivory, which usually shows the parallel or intersecting "lines of Retzius". The necklace is fashioned from the inner part of the teeth. It is displayed in the Geological Museum, London, along with a sectioned bead and a sectioned walrus tooth, together with other types of ivory.

The photographs, taken by Mr J. M. Pulsford, show transverse and longitudinal sections of walrus ivory and the stained sectioned bead from the necklace. Photographic techniques have been used to increase the contrast in these pictures, but in unstained specimens the structures will need to be sought for with some care.

#### REFERENCES

- Webster, R. 1944-1946. *Ivory: Its Varieties and Imitations*. Gemmologist, Vols XIII, XIV and XV. (Walrus, p. 53, Vol. XIII).
- Williamson, C. G. 1938. *The Book of Ivory*. London.

## LARGE ASIAN YELLOW CAT'S-EYES

By HELEN L. MACLEOD, F.G.A.

TWO large yellow cat's-eyes, each over 30 carats, were bought in the Orient as chrysoberyl cat's-eyes for some thousands of dollars. One, which had been badly scratched and worn, had been repolished in New York, by a dealer who at one time had it on memorandum. These stones were shown to Antonio C. Bonanno, F.G.A. (National Gem Appraising Laboratory, Silver Spring, Maryland) with the object of selling one of them.

Mr Bonanno had the feeling that one stone (the one that had had the polishing job) didn't look right, although a perfect match in colour. Sure enough, when the two were dropped in methylene iodide, this one floated and so could not be chrysoberyl. The owner was shocked and asked for identification.

Its specific gravity, by hydrostatic method, proved to be 3.18, a trifle heavy if it was a tourmaline, but narrow metallic-type needle inclusions in parallel orientation would account for this. The cabochon had a rough back, and the spot method for determining refractive index gave a reading of 1.63, of course within the tourmaline range. An electrostatic test by rubbing gave negative results for the top of the stone, but positive on the side or lateral portions. Yellow cat's-eye tourmaline was therefore a good guess *but tourmaline it was not*.

A check with a spectroscope had revealed none of the significant lines (didymium) that most people associate with apatite, which has, of course, a refractive index and specific gravity very close to tourmaline under the test conditions applied in this case. Mr Bonanno had examined yellow cat's-eye apatites with the spectroscope before: he had found the rare earth lines in specimens from Mexico, but *not* in those from Asia. For a definite answer, a careful hardness test was carried out.

The gem, which was apatite, *must have been unduly easy to polish*. No discussion or testing could have taken place at the time it was offered to the trade. It is important to bring out these details for the reason that many chatoyant apatites, though seldom this large, are appearing on the market. They are of minimal value, but may be bought and sold by the ignorant as chrysoberyl, and even the fairly knowledgeable might think they had yellow tourmaline, a fairly rare material in its own right.

# Gemmological Abstracts

---

BANK (H.). *Durchsichtiger farbloser bis bläulicher Sillimanit aus Kenya*. (Transparent colourless to bluish sillimanite from Kenya). Z. Dt. Gemmol. Ges., 1974, 23, 4, 281-282.

The mineral sillimanite is found quite frequently in metamorphous rocks. It is usually found in thin, long, or ray-like or fibre-like crystals and can only seldom be used for cutting. Some specimens found in Burma have long been known to be cuttable: now Kenya has yielded further cuttable sillimanite. E.S.

BANK (H.). *Durchsichtiger saphirblauer Sodalith von SW Afrika*. (Transparent sapphire-blue sodalite from S.W. Africa). Z. Dt. Gemmol. Ges., 1974, 23, 4, 279-280.

Sodalite, which is chemically  $\text{Na}_8[\text{Cl}_2(\text{Al Si O}_4)_6]$ , was said to be glass because of its  $n=1.486$  singly refractive index. However, this has now been found to be sodalite from the northern part of S.W. Africa. E.S.

BANK (H.). *Über Brechungsindizes brasilianischer Smaragde*. (About refractive indices of Brazilian emeralds). Z. Dt. Gemmol. Ges., 1974, 23, 4, 297-298.

The author shows that the values of the refractive indices of Brazilian emeralds are not as low as usually given in gemmological tables, but that the commercially available emeralds from Brazil on the market today show high values. E.S.

BASTOS (FRANCISCO MULLER). *Maxixe type Beryl*. Lapidary Journal, 1975, 28, 10, 1540-1542.

Stones examined in Brazil were of varying colours, some being similar to aquamarine, others being a cobalt blue closer to blue zoisite. Some stones were such an unusually fine dark blue that they at first resembled the stones first found at Maxixe, Piauhy, Brazil. An unstated process was used to change the colour of light pink beryls to the dark blue; the light pink stones altered to a cobalt blue, though two other stones of a similar colour from the Barra de Salinas area did not alter. The duration of the experiment was 9 days. No deterioration of the colour was experienced after a period of exposure to light lasting one month. This alteration of colour is only possible with pink beryls from a certain area and the commonest change is to a light blue. Some stones on heating returned to their original light pink; on being subjected to the experimental technique once more they again altered but to a less fine blue than formerly. No report of any kind of irradiation is mentioned. M.O.D.

BROUGHTON (P. L.). *Emerald deposits of Western North Carolina*. Earth Science, 1974, 27, 4, 222-228. 2 illus; 1 map.

An article giving a good account of the emerald mines of North Carolina, and in particular the Rist and Ellis mines of Alexander County. These mines are open to the public who, for a fee, can search for emeralds. Much is told of the history and the type of occurrences. An interestingly written factual article. R.W.

CASSEDANNE (JACQUES P. and JEANNINE O.). *Note sur la mine d'émeraude de Carnaiba.* (Note on the Carnaiba emerald mine.) Bulletin de l'Association Française de Gemmologie, 1974, 40, 4-8.

The mine, in the state of Bahia, lies south-west of Senhor de Bonfim, which is south of Juazeiro and west of Aracaju. The regional geology consists of quartzites with schists with some occurrence of gold and diamond. Close to Carnaiba there is a granite intrusion and the emeralds are found in a rock composed of phlogopite, with quartz, apatite and biotite. This is known as "sludite". The emeralds have a hardness of 7.5, a density of 2.72, a refractive index of 1.572 and 1.566. No change is observable through the colour filter and there is no fluorescence. Inclusions consist of mica plates, with two-phase inclusions. M.O'D.

DERN (H.). *Der Billiansche Wirbelschliff.* (The Billian spinal cut). Z. Dt. Gemmol. Ges., 1974, 23, 4, 319.

A new cut for gems described by Otto Verbasius Billian from Brazil, variable with material, can be used to produce octagons, or even 10- or 12-cornered stones. The angles are optimal. E.S.

DERN (H.). *Ein neuer synthetischer Sternkorund.* (A new synthetic star-corundum). Z. Dt. Gemmol. Ges., 1974, 23, 4, 294-296.

J. C. Smith and J. M. J. Watts of the United Carbide Corporation of New York have patented in 1973 in Munich a new method of producing synthetic star corundums. The titanium dioxide which produces the asterism and the colouring material are regularly distributed throughout the stone, by pulling a seed crystal out of the melt while rotating it round its c-axis. The crystal is then heat-treated, overshooting the solubility limit of the titanium solution, thus forming an aluminium titanate which produces the asterism. This synthetic material can be distinguished from the natural corundum by its growth lines, which in the natural stone are hexagonal, while concentric circles can be seen in the synthetic product. E.S.

DERN (H.). *Das Reiben von Diamanten.* (Bruting of diamonds). Z. Dt. Gemmol. Ges., 1974, 23, 4, 308-315.

This is part I of an article written for the amateur lapidary who would like to try his hand with diamonds. It explains the crystallographic growth of the stone, as well mentioning some of the tools used in the process: various dops are described, as are also a couple of bruting machines. E.S.

DOEPFEL (E. H.). *Rhodonite and bustamite from Daghazeta/Tanzania.* Z. Dt. Gemmol. Ges., 1974, 23, 4, 283-285.

Recently Bank, Berdesinski and Diehl published a paper on rhodonite found in Broken Hill, Australia, which led to this investigation of the joint occurrence of rhodonite and bustamite in Tanzania, Daghazeta. The formation of quartz and spessartite next to bustamite seems to be connected with the decomposition of rhodonite, which appears to be controlled by interlacing fissures and fracture zones. The Daghazeta deposit seems to have been formed firstly by the formation of rhodonite and granulite as a result of regional metamorphism and secondly by the alteration of rhodonite and the augite-containing host rock under special conditions. E.S.



DUNN (PETE J.). *Emeralds in the Smithsonian Gem Collection*. Lapidary Journal, 1975, 28, 10, 1572-1575.

Some recent acquisitions by the Gem Collection, including the Spanish Inquisition necklace and other pieces of Persian design, are described and illustrated. M.O'D.

DUNN (PETE J.). *Elbaite from Newry, Maine*. Mineralogical Record, 1975, 6, 22-25.

Gem quality tourmaline has been rediscovered at the Dunton pegmatite on Newry Hill, Maine. The crystals are mostly zoned parallel to the prism and show a light green rind over a red core. Lengths of up to 27 cm have been recorded. M.O'D.

DUNN (PETE J.). *Chromian spinel inclusions in American peridots*. Z. Dt. Gemmol. Ges., 1974, 23, 4, 304-307.

The peridots examined were found in Arizona and New Mexico. The purpose of the examination was to study the euhedral, equant, dark inclusions often found in stones from these localities. Method of preparation and examination is described in detail: the inclusions were found to be chromian spinel. E.S.

EPPLER (W. F.). *Einschlüsse im Vanadium-Beryll*. (Inclusions in vanadium beryl). Z. Dt. Gemmol. Ges., 1974, 23, 4, 300-303.

The inclusions in the new light green vanadium beryl consist mainly of greyish-white spots and streaks distributed in large numbers throughout the stone. Occasionally they are accompanied by small black spots which are ore. Some parts of the stone can be full of very fine 'dust' giving the stone a matt, sleepy appearance. These various inclusions are illustrated by photomicrographs. E.S.

EPPLER (W. F.). *Synthetischer Alexandrit und synthetischer Opal*. (Synthetic alexandrite and synthetic opal). Z. Dt. Gemmol. Ges., 1974, 23, 4, 286-293.

Synthetic alexandrite was first manufactured commercially in 1972 and was then described by Liddicoat (*Gems & Gemology*, 1972/73, XIV, 4, 102-104). Hardness was  $8\frac{1}{2}$ , S.G. 3.71 and R.I. 1.75 and 1.76. The same firm has now made a new synthetic alexandrite, which shows a good green in daylight, at night being definitely red, perhaps a little violet. The physical characteristics are the same as before. The inclusions, however, are quite different, showing now arched growth lines which consist of net-like liquid inclusions. These alexandrites also show irregularly formed and irregularly placed black spots and some fine thin needles. Photomicrographs are shown. The prices for these synthetics are very high (\$300 to \$500 per ct). The author describes his own experiments of alexandrite synthesis, and also describes shortly the synthetic Gilson opal first seen in about 1972 in U.S.A. These synthetic opals consist of regularly arranged 'balls' of cristobalite which produce the opalization. In the case of black opals the matrix is not black or grey, but definitely brown-black. E.S.

HASSAN (F.) and COHEN (A. J.). *Biaxial color centers in amethyst quartz*. American Mineralog., 1974, 59, 7/8, 709-718.

Anisotropy of the characteristic absorption bands in a natural Brazilian amethyst is demonstrated. The biaxiality and pleochroism of amethyst is explained

as due to the existence of strongly anisotropic colour centres, related to iron, of orthorhombic or lower symmetry. When the colour is bleached optically or thermally, the biaxiality also disappears. This anomalous biaxiality and pleochroism in amethyst is a property of the colour centre and not of the quartz crystal structure.

R.A.H.

JENKINS (WILLIAM J.). *A photographic method of observing striae in corundum*. Lapidary Journal, 1974, 28, 8, 1258–1260.

A penpoint flashlight using a bulb with a built-in lens is substituted for the stopped-down enlarger as the light source. The converging rays are virtually parallel so that contact prints can be made from negatives which are not actually in contact with the printing paper. There is no need to use an immersion cell or liquid. Exposure time should be  $\frac{1}{4}$ – $\frac{1}{2}$  second and film sensitive below 4000Å is used.

M.O'D.

LESTER (J. G.). *Gem minerals of Georgia*. Rocks & Minerals, 1974, 49, 131–135.

A comprehensive list is given of gems which have been reported in Georgia. Special emphasis is placed on occurrences of diamond, ruby, topaz, aquamarine, golden beryl, almandine, gahnite, apatite, lazulite, kyanite, and quartz (amethyst, smoky, agate, jasper).

R.S.M.

MALTBY (LAWRENCE J.). *Photography for the rockhound. Part 1*. Lapidary Journal, 1975, 28, 10, 1526–1530.

The author uses a 55 mm Micro-Nikkor-P lens for close-up photography; the aperture ranges from F 3.5 to F 32 and the photographs accompanying the article were taken at F 32. The camera body used is a Nikon F with a Photomic FTN finder. Kodachrome II film is useful since the grain is fine; as it is now being phased out of production, the Kodachrome 25 should be a satisfactory replacement. Flash equipment used for the illustrations to the article was the Honeywell Auto/Strobonar 770.

M.O'D.

MERTENS (R.). *Die Achate Idar-Obersteins zum gegenwaertigen Zeitpunkt*. (The agates of Idar-Oberstein at the present time). Z. Dt. Gemmol. Ges., 1974, 23, 4, 316–318.

The industry in Idar-Oberstein was originally founded on the local agates. Today the finds are not of commercial value but of great interest to collectors. Details of local occurrences are given. The article is illustrated by 3 photographs of 3 attractive local finds.

E.S.

MCCRILLIS (DEAN A.). *Gem tourmaline rediscovered at Newry*. Mineralogical Record, 1975, 6, 15–21.

An account of the events leading to the discovery and notes on the working of the gem tourmaline from Newry, Maine.

M.O'D.

NASSAU (K.). *The effect of gamma rays on tourmaline, greenish-yellow quartz, pearls, kunzite and jade*. Lapidary Journal, 1974, 28, 7, 1064–1084.

Colours induced in tourmaline by gamma radiation include pale colours to deep pink, medium pinks to deep pink or yellow, blue to purple and pale green

to a bicoloured pink and green. Some of the new colours are light- and heat-resistant, others are not. A bright greenish-yellow has been produced by irradiating some Brazilian quartz and then gently heating it. This colour is unstable. Pearls may be turned grey, bluish-grey or blue, and this colour is stable. Kunzite, turned to a deep green, is bleached by light exposure or heating. No major colour change can be detected in irradiated jadeite or opal. M.O'D.

POIROT (J. P.). *Une application ancienne de l'observation des inclusions en bijouterie-joaillerie.* (An old application of the observation of inclusions in jewellery). Fend. Soc. Italiana Min. Petr., 1974, 30, 417-422. 7 figs.

The author points out the importance in jewellery of the observation of inclusions for distinguishing natural gems from artificial ones. F.M.

ROSSMAN (G. R.). *Lavender jade. The optical spectrum of  $Fe^{3+}$  and  $Fe^{2+} \rightarrow Fe^{3+}$  intervalence charge transfer in jadeite from Burma.* American Mineralog., 1974, 59, 718, 868-870.

The optical spectra of green, white and lavender jadeite have been studied. Ferric iron is responsible for the colour in the green jadeite. It is suggested that ferrous-ferric iron intervalence charge transfer is responsible for the lavender colour of jadeite. Material sold as 'colour-enhanced lavender jade' has the same spectral features as genuine lavender jadeite and has probably undergone heat treatment which would affect the oxidation state of a small proportion of the iron present. R.A.H.

SCHMETZER (K.), MEDENBACH (O.) and KRUPP (N.). *Das Mineral Kornerupin unter besonderer Berücksichtigung eines neuen Vorkommens in Kwale Distrikt, Kenya.* (About the mineral kornerupine with special reference to a new find in the Kwale district in Kenya). Z. Dt. Gemmol. Ges., 1974, 23, 4, 258-278.

The article describes in detail the cuttable light green kornerupine recently found in the Kwale district in Kenya. This kornerupine is found in prismatic crystals, which are up to 10 cm long, next to crystalline micas, quartz, sillimanite, disthene, tourmaline, muscovite and biotite. The optical data at 589 nm are  $n_x = 1.660$ ,  $n_\beta = 1.673-1.674$ ,  $n_\gamma = 1.675$ . The lattice constants are  $a_0 = 15,998$ ,  $b_0 = 13,698$ ,  $c_0 = 6,704$ . In microanalyses the  $V_2O_3$  content was found to be 0.22%. By spectroscopic examination it was established that the green colour was caused by the  $V^{3+}$  content. The new data are compared with previously published data in an extensive bibliography of 51 items. Various photomicrographs, including interference figures, illustrate the article, which also has tables giving the various occurrences of kornerupine, optical and chemical data, d-values and lattice constants and absorption bands. E.S.

TINSLEY (T. C.). *Jet from Colorado.* Earth Science, 1974, 27, 2, 106-108. 2 illus.

Originally written as an academic thesis, this article introduces the reader to a little known source of jet found at El Paso County, Colorado in the United States of America. Considerable work has been shown to have been done on the scientific side and on the comparison with the jet found in Utah. Some historical facts are given which include the fact that the material was shipped to England in the 1870s and 1880s and then sold as 'Whitby jet'. There was a local industry

in Colorado for this jet during the 1920s. The Colorado locality for jet has often been mentioned in the past; that at Trincheria Mesa is said not to be factual.

R.W.

YEREMENKO (G. K.) and POLKANOV (YU. A.). *Luminescence of small diamonds from sandy sediments of the Ukraine*. Dokl. Acad. Sci. USSR, Earth Sci. Sect., 1969, 188, 149–151. 2 figs. Transl. from Dokl. Akad. Nauk SSSR, 1969, 188, 905–908.

Many of the Ukrainian diamonds show orange-red photo-, x-ray-, and cathodo-luminescence. Most of the crystals are cubes and most are coloured. Filtered radiation from a mercury-quartz lamp was used to excite the radiation at room temperature and at 77°K. Their spectrogram consists of a broad yellow line at 575.5 m $\mu$  accompanied by a continuous band extending to 650 m $\mu$ . Microphotometer curves and a table of the spectrum are given.

T.B.

ZEITNER (JUNE CULP). *Feldspar gems in the United States*. Lapidary Journal, 1974, 28, 8, 1204–1216.

The various occurrences of feldspar in the United States are reviewed.

M.O'D.

ZEITNER (JUNE CULP). *The world's most expensive minerals*. Lapidary Journal, 1975, 28, 10, 1532–1538.

Coloured illustrations and a description of the David Wilber collection of minerals, including a phosphophyllite from Potosi, Bolivia, and a proustite from Chanarcillo, Chile.

M.O'D.

---

## BOOK REVIEWS

ARGENZIO (VICTOR). *Diamonds eternal*. David McKay Co., New York, 1974. pp. xii, 290. Illustrated in black-and-white. \$12.50.

Written in an easy style, this book deals with all aspects of the diamond trade from mining to the care of stones in jewellery. There are some sensible remarks on synthetic gem diamonds, though no account of their manufacture and identification, and the chapter on investment is also clear and informed. There is a short bibliography, rather annoyingly linked with the chapters so that it becomes unnecessarily repetitious.

M.O'D.

BANCROFT (PETER). *The world's finest minerals and crystals*. Thames & Hudson, London, 1973. pp. 176. Illustrated in colour. £8.50.

Seventy-two minerals are illustrated in full-page, high-quality photographs. Each has been selected by the curator of a notable collection and facing the plate is a page of description. Introductory matter includes a map of mineral deposits, on too small a scale to be really useful, but then this is not intended as anything other than a book to lift the spirits, which it does. M.O'D.

BAUER (JAROSLAV). *A field guide in colour to minerals, rocks and precious stones*. Octopus Books, London, 1974. pp. 208. Illustrated in black-and-white and in colour. £1.50.

Translated from the Czech and printed in Czechoslovakia, the most remarkable feature of this useful if unexciting book is its price. Introductory chapters lead to an encyclopaedic section in which the specimens are arranged by colour. Good features include the presentation of illustration and text on the same opening: less welcome ones are the arrangement of the gems in order of value and the statement that microscopic examination of synthetic emerald does not provide reliable proof of its origin. M.O'D.

BURNS (ROGER G.). *Mineralogical applications of crystal field theory*. Cambridge University Press, Cambridge, 1970. pp. xii, 224. £4.50.

Crystal field theory has application to elements of the first transition series and this book relates the theory to geochemical and mineralogical work. Of particular interest are the data on absorption spectroscopy and the methods used for determining cation distributions in silicate crystal structures. There is a good bibliography. M.O'D.

EVANS (D. EMLYN). *Investigating minerals*. Reprinted from the Bulletin of the National Museum of Wales, no. 10, Spring 1972. pp. 15. Illustrated in black-and-white. £0.24.

A simple guide to basic mineralogical techniques designed for children and visitors to the mineral galleries of the National Museum of Wales. M.O'D.

ROBERTSON (MARIAN). *Diamond fever. South African diamond history 1866-9 from primary sources*. Oxford University Press, Cape Town, 1974. pp. 250. Illustrated in black-and-white. £5.00.

Much of the material included in this book is taken from letters in the Cape Archives and from material recently deposited in the De Beers Old Mine Museum; new light is shed on the discovery and sale of the first South African diamond. Those interested in the early marketing of diamond will find this book useful. There is a bibliography. M.O'D.

SADANAGA (RYOICHI) and BUNNO (MICHIAKI). *The Wakabayashi mineral collection*. University of Tokyo Press, Tokyo, 1974. pp. 177. Illustrated in black-and-white and in colour. £11.20.

This collection, made by Dr Yaichiro Wakabayashi from 1889 to 1943, is housed at the University Museum at the University of Tokyo. 182 species are

represented by 1,932 specimens and classification is in Dana order. Almost all are from Japanese locations and the mines themselves are given in the descriptions.  
M.O'D.

SCHAWLOW (ARTHUR L.). *Lasers and light. Readings from Scientific American*. W. H. Freeman & Co., San Francisco, 1969. pp. vi, 376. Illustrated in colour. £2.80.

A series of papers from *Scientific American*, this excellent book is a basic introduction to lasers and their properties. More important, it introduces concepts in optics which are vital to the understanding of the operation of present-day optical devices and which provide useful and colourful revision notes on original studies.  
M.O'D.

TENNISSON (ANTHONY C.). *Colorful mineral identifier*. Oak Tree Press, London, 1973. pp. 224. Illustrated in colour. £1.95.

This handy field guide is designed for the pocket and is a translation of *Bunte Welt der schönen Steine* first published in 1969. Specimens are grouped in Dana order and descriptions face the photographs. The standard of illustration is quite high for such a cheaply-priced book.  
M.O'D.

*Compilation of crystal growers and crystal growth projects*. Research Materials Information Center, Oak Ridge National Laboratory, Tennessee, U.S.A., 1972. pp. v, 142. Price on application.

A most useful directory and guide to the synthetic crystal scene in the United States, this book should alert scientists to the possibilities of man-made materials. This also applies to the gemmologist. Entries are alphabetical under company or other organization concerned and contain the names of the people actually involved and the telephone number; also details, with chemical compositions given, of the products under current research.  
M.O'D.

*Journal of the Gemmological Society of Japan*. Vol.1, no. 1, Oct. 1974. Address: c/o Institute of Mineralogy, Petrology and Economic Geology, Tohoku University, Aoba, Sendai, 980 Japan. Foreign subscription, U.S.\$10.00.

This excellent new journal is in Japanese with English abstracts which could well be amplified to extend the coverage. Articles in this first issue include Jadeite from the Kotaki-Omi area, Niigata Prefecture, Japan; biomineralogy and pearl culture; synthetic gemstones; natural and synthetic gemstones newly appeared after the second world war; gem news in the form of short notes; abstracts and society notes.  
M.O'D.

---

---

# ASSOCIATION NOTICES

---

---

## OBITUARY

### DR E. H. RUTLAND, F.G.A.

The sudden and utterly unexpected death of Dr E. H. Rutland on 16th January came as a great shock and a great sorrow to his many friends both inside and outside the field of gemmology.

Ernest Hugo Charles Rutland was born in Czechoslovakia 67 years ago and came to England at the age of 14. He was educated at Manchester Grammar School and later at Cambridge University. After taking his M.A. he lived for a while at Toynbee Hall and from there took his Ph.D. degree in the field of statistics—giving him a specialized knowledge of this subject which he put to good use in his subsequent professional life. While at Toynbee Hall, he served as one of the counsellors in the wonderful Samaritan organization—an indication, at that early age, of the breadth of his humanity.

For most of his professional life Ernest Rutland was a Civil Servant in the Ministry of Town and Country Planning and lived for many years with his wife Jill in Hampstead Garden Suburb. In 1948 he took over from his close friend Eric Levett the small but specialized jewellers shop in Hampstead known as Frances Harling after its originator, and Jill Rutland ran the business for some years while Levett was in Rhodesia.

I first came to know Ernest Rutland as an outstanding student in the 1946/47 second-year gemmology classes at Chelsea Polytechnic, when he showed his calibre by sharing the Tully Medal award with another enthusiastic amateur, Lieut-Col. G. M. Sprague, who was still in the Army and took the course by correspondence. In this same post-war class, it is interesting to recall, such well-known personalities as A. E. Farn, Werner Stern and Harry Wheeler also obtained their Diplomas with Distinction. Rutland continued to attend Chelsea Poly in the Post-Diploma class until 1950. Then, when Thorold Jones left teaching to take up an appointment with the A.E.R.E. at Harwell, Rutland's talents were put to good use as a lecturer for the first-year classes at Chelsea. At that time the numbers enrolling in these had swollen to some 80 students, who could only be accommodated by splitting the class between two evenings. Rutland was immediately successful and popular as a teacher, and his knowledge of gemmology became enriched by the experience. Whenever I dropped in to his lecture-room after finishing with my Post-Diploma class he was always still at the lecture bench, surrounded by interested students. During the ensuing years he wrote a number of articles for the Journal, and in 1953 Rayner made to his design the useful vest-pocket polariscope which bears his name.



E. H. Rutland in the Laboratory at 15 Hatton Garden  
(Photo B.W.A.)

Such was his knowledge and standing as a gemmologist that, after retiring from the Civil Service, he was able to stand in for Mr Alan Jobbins at the Institute of Geological Sciences in 1968 when the latter was doing a very useful spell of duty in Rangoon in organizing the gemmological training in Burma, and he continued as a Principal Scientific Officer in the Mineral Resources Department of the Institute until the end of November, 1969, when he and his wife made their home in Swanage.

This, however, by no means terminated the usefulness of Rutland's career in gemmology. When, at the end of 1970, Dr Claringbull ended his long spell of 42 years as an examiner for the Gemmological Association, Ernest agreed to join John Chisholm and myself as an examiner for the Diploma course.

Rutland was a long-standing member of the Mineralogical Society and of the Deutschen Gemmologischen Gesellschaft, whose meetings in Idar-Oberstein he often attended. His knowledge of German enabled him to translate very successfully Prof. Hermann Bank's superbly illustrated book, "From the World of Gemstones", the English edition of which was published in 1971. This considerable task was, one felt, not adequately acknowledged, but fortunately not long afterwards Hamlyns were in search for an author who would undertake to write a popular book on gemstones for them at rather short notice, and Rutland, at my suggestion, agreed to meet their needs. The result was a very attractive and lavishly



illustrated book, "An Introduction to the Gemstones of the World", which duly appeared in the summer of last year. This was brilliantly and succinctly written and should achieve lasting popularity. One can be very thankful that Ernest saw this crowning contribution of his to gemmology reach completion and received from his friends the congratulations he deserved.

In all his walks of life, of which I have only been able to give an outline, he gathered firm friends. This was true even in his last few years when, though relatively a newcomer in Swanage, he had already begun to play an active part in the local community. And of course it is as a friend that we shall miss him most—remembering his unfailing kindness, his tolerance, his humour and his unshakeable reliability. Ernest Rutland was a big man: big physically, big mentally, and big in spirit. It is hard indeed to have to say farewell.

B.W.A.

Mr J. M. B. McWilliam, Glasgow, who gained the Association's Diploma in 1938, died on 27th December, 1974. He was a member of Council from 1968 and assisted a great deal with the evening classes in gemmology in Glasgow and the setting up of a gem-diamond class in that City.

Mr Leslie Payne, Southampton, who gained the Association's Diploma with Distinction in 1952, died on the 12th January, 1975. For a number of years Mr Payne had been an instructor for the Retail Jewellers' Correspondence Courses conducted by the National Association of Goldsmiths.

### PRESENTATION OF AWARDS

There was a record attendance at the Presentation of Awards which followed the Members' Reunion at Goldsmiths' Hall on 25th November, 1974, including candidates from many different parts of the world.

Mr Norman Harper, the Chairman, said that in 1974 the candidates for the Preliminary and Diploma Examinations numbered 994, which was yet another record, and there were some present who had come from as far afield as Japan and South Africa, as well as others from Holland, Germany, Finland, Spain and, of course, the United Kingdom. After extending a welcome to Gordon Andrews, F.G.A., the former Secretary, and to the National Association of Goldsmiths' Chairman, Richard Cope, F.G.A. and Vice-Chairman, David Callaghan, F.G.A., Mr Harper said that Dr Eduard Gübelin, whose new book he praised, needed no introduction and asked him to present the awards to the successful candidates.

Professor Dr Eduard Gübelin, Ph.D., F.G.A., C.G., then presented the prizes, diplomas and certificates won in the gemmological and gem-diamond examinations and gave an address which is recorded in full below.

Dr Claringbull, the President, thanking Dr Gübelin, welcomed the presence of one of the Association's Honorary Fellows, Dr W. Campbell Smith, who was formerly Keeper of Minerals at the British Museum (Natural History): "in addition," he continued, "few would dispute that we have in the Hall this evening the two most eminent gemmologists in Europe—Eduard Gübelin and Basil Anderson." Both of them had made most valuable contributions to gemmology,

Mr Anderson in the field of absorption-spectroscopy, to which Church had pointed the path, and Dr Gübelin in the study of inclusions, following Michel. Dr Gübelin's recent book, *The Internal World of Gemstones*, was not only a wonderful book for the student of gemstones, but its superb colour photomicrographs were an inspiration to the artist and the industrial designer.

#### DR EDUARD GÜBELIN'S ADDRESS

In his address, following the presentation of awards, Dr Gübelin said:

What is happening on our planet today? I do not mean the belligerent tensions in the near East nor the failure to adopt a common energy policy nor the world-wide monetary crisis—no, what happens in this world as an entity, what happens at the present for the first time uniquely and so thoroughly that it will be remembered in the centuries to come, just as we still acknowledge and appreciate today the invention of the wheel, of the alphabet, the development of the great religions of the world, or from a geological point of view the folding up of the Alps, as an outstanding and irrevocable phenomenon. Well, what is happening in front of our eyes today? It is a tremendous and in its kind certainly a unique metamorphosis, which could at best compare with the change which mankind underwent during the dark ages and then again at the beginning of the Renaissance. The world happens to be in the midst of a fundamental change of structure with biological, physiological, sociological and even theological effects, and these are of such profundity that we cannot escape them.

To a certain extent we have been experiencing drastic changes also in our profession. Until recently, our ideas of sales promotion moved along perspectives which had already been fixed in medieval times and which were almost exclusively limited to the mere action of selling, and at best to a successful sales talk, while today after a short time of transition (calculating just a few years) great value is being placed in an extensive professional erudition, profound psychology, sound argumentation and efficient advice. While previously the old Roman warning *Caveat Emptor*, which originated from distrust, alerted the buyer to be careful, it now has the meaning that the client wishes to be well informed and accurately advised about the goods he is interested in purchasing. This desire may only be fulfilled by the salesman if he masters a fundamental professional knowledge. Science reigns today over all sequences of our life, medicine as well as commerce, production as well as communication, and the last consumer wishes to share in this professional science.

It is the aim of the gemmological courses, which you have so successfully completed, to offer this specialized knowledge which will give you greater self-assurance and consequently increase well founded trust to assist your clients in such a way as to justify the confidence they place in your hands. The relatively broad spectrum of knowledge taught in the condensed form of, say, 25 or 30 assignments distributed over two courses challenged your capability to understand connexions and relationships which exist between different disciplines of the science of nature as well as between different properties of gemstones. The capacity of thinking in relationships and coordinations as well as the readiness to engage yourselves and to take responsibility and to accept solidarity should, apart

from your technical achievement, be the human or spiritual benefit of your gemmological study. In this sense I wish to congratulate you most cordially on your successful attainment, which is the well deserved result of your perseverance and brave sacrifice during two years of intensive study. Not only your personal interest in gemmology has led you to this award but also your thirst for knowledge and education, that marvellous, growing, aching process, whereby the mind develops into a usable instrument with a collection of proved experiences from which to function.

Some of you may consider the diploma examination as the climax of your gemmological studies. Yet, may I bring to mind that this is rather the first "rung of the ladder"—that you have merely just crossed the threshold of a space spreading before you with no visible horizon, and the "heady" sensation you may feel now is only the beginning of further studies combined with unexpected experiences which perhaps are more closely linked with your practical everyday life in future. Therefore I recommend you to remain abreast of future developments by joining the advanced post diploma courses and subscribing to gemmological periodicals.

Your diploma should not mislead you to consider yourselves as infallible experts. Your *status quo* is comparable to the situation of a young B.Sc. or Ph.D. who has just received his academic title, which does not attest him yet as a fully fledged scientist but merely that he has learnt to think and act independently and—as is to be hoped—with a sense of responsibility.

In a specified course, like the one you have successfully accomplished, it is not possible to include everything relevant. It may set forth an optic, a direction, a theory or methods coupled with practical experience from which the student may think and act further, and we must remain aware of the limitations that we may properly use our own vocables only for the resources at our disposal.

Among the resources offered to the modern Science of Nature gemmology assumes a prominent place. Unfortunately it was considered a superfluous appendage and hardly acknowledged for almost a generation, and gemmological publications only appeared as foot-notes to mineralogical literature. Yet, indeed, as an independent basis, gemmology has often supplied mineralogy with fundamental data and proved to be of invaluable assistance. Gemmology was lacking professionalism for a long time and for far too long gemmology was merely a trade accessory. Gemmological degrees at present are still no more than school degrees, either awarded by trade associations or by private institutes affiliated with the trade. An academic degree course would help in upgrading the profession's standing similarly as university training would facilitate gemmology and gemmologists to meet the increasing technology and standard of investigation.

However, thanks to numerous outstanding achievements in highly scientific gemmological research, today gemmology is fully recognized as a science. As a matter of fact, gemmology is today rightly entitled to claim the merit of having essentially contributed towards the astonishing progress of mineralogical research. The endeavour to expand as far as possible the boundaries within which we human beings are placed, and the curiosity for the means by which this may be possible, is a central motive of technical and scientific development. It is the same force which led our progenitors to master the use of fire and which drives us to-day to investigate outer space without knowing where this may lead us to. This intense desire of mankind to question all boundaries again and again is already grappled

in the Genesis of the Old Testament by the words "Conquer the Earth with all that is within" and thus deprived of any further argumentation. However, if man conquers the Earth, then he must corroborate by his mental disposition as well as by his moral conduct that he is indeed legitimized for this role—not only as a scientist but also in his quality as a human being.

By this I mean to emphasize that we have a right to profit from our knowledge to our own personal advantage, yet never to use it to the harm of others. A French philosopher expressed this thought with the following words: "Science sans conscience n'est que ruine de l'âme"—science without conscience is the undoing of one's soul. Scientific research means searching for the truth. Consequently, we are obliged to be honest and always tell the truth, and if we happen to make a mistake we should summon the courage to admit it.

Irrevocable laws do not only exist in the field of the sciences of nature but also in the sphere of human life and co-existence. In this connexion I may refer to the problematics of liberty and restraint, to all the tensions which occur because man is a personality who must develop in freedom, yet according to the laws of nature he is also a social being, who can only completely unfold himself in a society. It may not be superfluous to remind ourselves of this fact today, when sometimes righteously, but more often with no right whatsoever, scientific or social achievements are assaulted and when the behaviour of certain unscrupulous people assumes a most aggressive character. The essence of the intrinsic virtue of the thing stipulates a much more positive and courageous mind, in social, public, religious and scientific domains, in order to defend all these accomplishments of mankind and save them for future generations.

In this sense I bid you a successful future resulting from your freshly acquired gemmological knowledge; may many interesting tests be the source of personal satisfaction and happiness to you and the reason of increasing confidence placed in you by your clientele.

## **MEMBERS' MEETING**

### **Midlands Branch**

Mr George C. Walter, B.Sc., F.G.A., F.B.H.I., gave an illustrated talk on his experiences of diamond prospecting in Africa to members of the Branch on the 31st January, 1975, at the Auctioneers Institute, Birmingham.

## **GIFTS TO THE ASSOCIATION**

The Council of the Association is indebted to the following for their gifts: Mr Joseph Best, F.G.A., of Santa Barbara, Cal., U.S.A., who, before emigrating to the U.S.A., worked in the retail trade in Birmingham, for an excellent and comprehensive collection of synthetic materials including some cut specimens. Amongst the collection are white and purple apatite, lithium-niobate, barium sodium niobate, lithium tantalate, lanthanum aluminate, cadmium tungstate, and potassium tantalum niobate.

Mrs Susan M. Warner, B.Sc., Salisbury, Rhodesia, for a copy of her "Check List of the Minerals of Rhodesia", Rhodesia Geological Survey, Bulletin No. 69 (published 1972).

## STOLEN GOODS

Among stolen goods recovered by the police in Brighton are a Beck prism hand-spectroscope, a Rayner refractometer and a Herbert Smith refractometer in a box on which the name "Walford" is written. Anyone identifying these goods should communicate with the Letchworth Police Station, Hertfordshire.

## GEMMOLOGISTS' VISIT TO IDAR OBERSTEIN

A party of forty-seven jewellers and gemmologists visited Idar Oberstein at the end of October, 1974, on a conducted tour organized by *Watchmaker Jeweller & Silversmith* in collaboration with the Gemmological Association and the National Association of Goldsmiths. The party first visited the new bourse, where they were welcomed by the President, Konrad Wild. Then they spent some time on the buying floor, before touring the standing exhibition and the museum, where exhibits contributed by the local dealers and cutters are on display. The party visited Konrad Wild's factory in the afternoon, where they saw the automated cutting of coloured stones "up to beryl". The stones are pre-cut to identical size and shape, travelling up to the cutter on a moving belt. The stones are then mounted in "combs" and facets cut and then polished in computer-controlled automatic machines.

On the second day the party visited the famous showrooms of Ruppenthal, which have aptly been described as Aladdin's cave. The third morning was given over to buying, members of the party revisiting the buying floor of the bourse or calling upon individual firms in the town. After lunch the party went to the warehouse of Julius Petsch, F.G.A., who has an interest in seventeen mines in Africa and South America, and imports rough. Here the party saw how gems arrive in Idar—oil drums full of amethysts, sacks of run-of-the-mine rubies and emeralds. They also saw the rough crystals being hammered to remove unwanted material and sorted for quality before being offered to the cutters in the town.

During the visit both Professor Dr Hermann Bank, F.G.A., and Julius Petsch, gave talks about the current situation in the gem trade and some of the problems which face those who deal in stones. Professor Bank explained the gemmological exhibition which was being set up in the *Gewerbehalle*, now the headquarters of the Gemmological Association in Idar Oberstein. He then gave a brief history of the industry in the twin towns. He said that the fact that the Romans in the second century A.D. had obtained stones from the area was proved by the existence in Roman jewellery of stones which according to their colour and their structure could only have come from that region. There was, however, no positive proof that stones were cut there at this date. They were certain, however, that from the twelfth century stones were both being found and cut in Idar Oberstein. And up to 1820 only stones found in the region had been cut there. Since 1834, though, the town had obtained the material for cutting from Brazil. Later, harder stones from other places were cut in the town, and the old sandstone-wheel-cutting which the town had developed could not be used for these. In 1875 therefore lapidary cutting had been introduced from Bohemia, where it had been practised since 1600 at latest. In 1884 diamond cutting also was introduced to

Idar Oberstein, and between 1960 and 1970 a lot of people had gone to Paris to learn stone engraving. Professor Bank then showed a series of slides illustrating the various types of gemstones and their physical characteristics.

Julius Petsch spoke next and said that Idar Oberstein was a place where in a relatively small geographical area you could find the biggest selection of stones from the very cheapest agates to the best diamonds. You could travel all over the world and not find the variety of cuts and colours that could be found in this town. It was not only in the town of Idar Oberstein that stones were cut, but also in all the surrounding villages. Most of the firms were small three-, four- or five-men businesses: and already they called themselves a factory when they had three men: these men were artists: they took the best out of the rough stone.

Because the industry was not concentrated it had been decided, he continued, that it was necessary to do something more to attract buyers from all over the world. This was why the industry had built the exchange buildings, in which over a hundred companies from all over the world had offices. The bourse was the only place where one could go from table to table and compare prices and make purchases on the spot.

He went on to explain that there were three types of cutter in Idar Oberstein. There were those who cut the ornamental stones, then there were those who faceted the coloured stones, and then there were the diamond cutters. Incidentally there were not so many diamond cutters at the present time because they could cut diamonds more cheaply elsewhere.

The fact that there was something of a falling off in demand for the cheaper to medium priced stones at the present time was not being reflected in the price of these, he said. The new mines still had to prove that they would give good production: and there were still big buyers at the mines in Brazil and in Africa and Afghanistan, who bought big lots and made them disappear, bringing them on the market again at a later date. This kept prices at a certain level.

Silver jewellery was, as they all knew, in fashion at the moment, he said; and for this there was a big demand for ornamental stones. Besides agates, many other stones were now being used such as the jaspers, the obsidians, rhodonite and sodalite. Such was the demand that the cutters who cut these stones had delivery times of three, four, five and six months. Also, stones were being cut to form bangles and rings, which made further demands on the cutters. At the present time too they were cutting a lot of beads in Idar Oberstein and the drillers of beads were hopelessly behind in their delivery dates. The orders were there: the beads were there: but they lacked their holes. The stone-drillers were specialists: not everyone could drill beads—it was very delicate work and was done by ultra-sonic machines nowadays.

What he thought would particularly interest the party, Mr Petsch went on, were some of the rumours that were currently going around. The South African government had for some time placed a restriction on the export of uncut tiger's-eye. They had opened cutting factories there, but these could not produce enough. Everybody still came to Idar Oberstein asking for tiger's-eye, but it wasn't there any more. He thought they would have to look round and replace tiger's-eye with another yellow stone in the near future. Dealers were also facing the same problem with malachite. This came from the Congo, and it was very difficult to get hold of good quality material. He then went on to talk about the

supply of tanzanite. The tanzanite mine in Tanzania no longer produced the same quantities. He had heard that the government-owned company responsible for producing stones in Tanzania had gone bankrupt and was no longer able to pay the workers. As a result fewer stones and smaller sizes were coming to Idar Oberstein, and this mine was the only source in the world.

Stones which they had been seeing in Idar Oberstein, he then said, were wonderful almost emerald-green tourmalines from Afghanistan or Pakistan, probably from the border between the two areas. Unfortunately these often had imperfections, but they were better in colour than either the Brazilian or the African stones. Then there were the chrome grossular garnets from Kenya, which were still arriving, though the stones were in general not so big any more, a common size now being from half to one carat or even smaller.

Another stone he wanted to mention was the ruby from Kenya. Early in the year they had discovered in Kenya between Nairobi and Mombasa, near the Tanzanian border, a very large deposit of rubies. These stones had Burmese colour. An area of about fifty square miles had been prospected. In one place John Saul had found stones in considerable quantities. Ninety per cent of the stones found so far were only suitable for cabochon cutting, however, and only ten per cent were suitable for faceting. He felt that stones of four or five, or even eight to ten carats, would come out of this area. He didn't think that there was any fear that prices would tumble down as a result of this find, though, because the people who dealt in fine rubies had plenty of money to buy up the good stones and would regulate the price. But cabochon quality stones were coming out in quantity and he thought that in future it would be possible to buy for a good price stones from one to twenty carats.

He was convinced that stones for faceting other than cheap citrines would not in future be as readily available as they were in the past. Every time he sold stones, it was more difficult to replace them, even from his own mines. The demand was growing. Even the Chinese were beginning to buy stones. Prices would go up and deliveries would be more difficult. As a result, in his opinion people should look more to cabochon material in tourmaline, aquamarine, amethyst, ruby and emerald. The jeweller would have to persuade the customer to buy these stones for their colour, because of course one did not produce clean cabochons. If a stone was clean it was faceted.

He went on to talk about some wonderful aquamarines that had appeared on the market about a year ago, of a wonderful tanzanite blue. A lot of dealers had purchased these and paid 500 marks a carat for them. After some time exposed to the daylight—as little as eight to ten days—these aquamarines lost their colour. Jewellers who had bought them and put them in their windows found that they turned white. Tests were made and it was found that colourless beryls placed under x-rays could be changed from white to this wonderful blue colour.

Another stone they had seen recently in Idar Oberstein was blue precious topaz, cut stones up to 20 carats of good colour without blemishes. Suddenly they appeared at the bourse in large quantities, a thousand to two thousand carats. Nobody knew the rough stone source of these, so rumours were rife that these stones also had been treated by x-rays or nuclear rays to change a colourless topaz to the beautiful blue. But up to now, he said, nobody could prove whether these stones were treated or not. But he said the retailers bought a lot of aquamarines

and tourmalines that had been heat-treated. One could often turn dirty brown beryl into a very fine blue stone by heat-treatment. If in the twentieth century they could use modern technology to turn colourless stones into blue precious topaz, and the colour would remain, why should they not use this method also? The heat-treatment of aquamarine and tourmaline had been practised for over a hundred years and nobody objected. Eighty per cent of all aquamarines are heat-treated, he added.

Julius Petsch then went on to show a series of slides he had taken at various mines, including those he had taken when he visited the new ruby mines in Kenya. This mine, he said, had been found by the geologist John Saul who had been looking for chrome tourmalines. He had found tourmalines, but as he had dug down he came to gneiss rock, and here he had found the rubies.

### FURTHER VISIT TO IDAR OBERSTEIN

The *Watchmaker Jeweller & Silversmith* will be arranging a second trip to Idar Oberstein for early October, 1975, and the dates will be announced shortly.

### COUNCIL MEETING

At the meeting of the Council held on Wednesday, 5th February, 1975, the following were elected to membership:

#### FELLOWSHIP

Alvarez Fernandez, Laurentino, Grado-Oviedo, Spain. D. 1974	Goerlitz, Rolf M., Idar-Oberstein, W. Germany. D. 1974
Alvarez Fernandez, Manuel, Grado-Oviedo, Spain. D. 1974	Heaviside, Desmond, Great Ayton, Cleveland. D. 1974
Amoros Angel, Julio, Valencia, Spain. D. 1974	Heintzberger, Cornelis P., Bilthoven, Holland. D. 1974
Anderson, Susan M., Salisbury, Rhodesia. D. 1974	Hettema, Jan A. H. M., Silvolde, Holland. D. 1974
Ashley-Cooper, Elizabeth J., London. D. 1974	Hill, Roger C., Whitecraigs. D. 1974
Berkowitz, Rosa, Toronto, Ont., Canada. D. 1974	Hofelt, Joris C., Utrecht, Holland. D. 1974
Booker, Peter E., Melton Mowbray. D. 1974	Holt, Paul, Tuckahoe, N.Y., U.S.A. D. 1974
Campon Fernandez, Enrique, Oviedo, Spain. D. 1974	Hulse, Kenneth M., Sale. D. 1974
Carlsen, Gunnar J., Jr, Haugesund, Norway. D. 1974	Ishikawa, Taeko, London. D. 1974
Clewlow, Alan J., Braintree. D. 1974	Jayasinhji, Prince of Dhrangadhra, Dhrangadhra, India. D. 1974
Eagleton, David, Sheffield. D. 1974	Jimenez Torro, Vicente, Valencia, Spain. D. 1974
Engel, Gerhard, Idar-Oberstein, W. Germany. D. 1974	Kammerling, Manfred, Idar- Oberstein, W. Germany. D. 1974
Ferrer Arbona, Santiago, Valencia, Spain. D. 1974	Klar, Michael A., Idar-Oberstein, W. Germany. D. 1974
Garcia Igual, Arturo, Valencia, Spain. D. 1974	Langthon, Kjell-Odvar, Oslo, Norway. D. 1974



- Larah, Howard A., Manchester.  
D. 1974
- Latre David, Jose, Valencia, Spain.  
D. 1974
- Leyser, Karl-Georg, Kirschweiler,  
W. Germany. D. 1974
- Lopez Perez, Oceano, Barcelona,  
Spain. D. 1974
- Maes, Jurgen, Kirschweiler,  
W. Germany. D. 1974
- Manser, Jutta E., Southampton.  
D. 1974
- Matsumoto, Kikuo, Gunma-ken,  
Japan. D. 1974
- Maymo Mas, Jaime, Barcelona,  
Spain. D. 1974
- O'Rourke, Edward T., Brisbane,  
Queens., Australia. D. 1974
- Pearson, Barry E., Southport,  
Merseyside. D. 1974
- Rosenberg, Joya, Chevy Chase, Md,  
U.S.A. D. 1974
- Rovira Rabell, Manuel, Barcelona,  
Spain. D. 1974
- Salloway, Mary A., Lichfield.  
D. 1951
- Sanchez Cabello, A., Valencia,  
Spain. D. 1974
- Sato, Ikuo, Miyagi-ken, Japan.  
D. 1974
- Scrymgeour, David J., Newton  
Abbot. D. 1974
- Snyder, Julia T., Philadelphia, Pa.,  
U.S.A. D. 1974
- Tatiwala, Nawal K., Jaipur, India.  
D. 1974
- Thum, Koh Teik, Penang, Malaysia.  
D. 1974
- Turner, Michael J., Stockton-on-  
Tees. D. 1974
- Van Duyvendijk, Pieke, Krimpen  
g/d Yssel, Holland. D. 1974
- Van Gogh, Mienneke, Epe (Gld.)  
Holland. D. 1974
- Van Thiel, Carolina J. S. M.,  
Helmond, Holland. D. 1974
- Villar Lopez, Luis Fernando,  
La Coruña, Spain. D. 1974
- Weeks, Milton D., Annandale, Va,  
U.S.A. D. 1974
- Wicks, Sylvia B., London. D. 1974
- Woodhouse, Neville, Inkersall.  
D. 1974

#### ORDINARY

- Aleksander, Michael, Kloten,  
Switzerland.
- Allen, John William, Hornchurch.
- Archbold, David, Hartlepool.
- Bates, Sandra H., Fareham.
- Bettis, Amanda E., London.
- Bloch, David H., San Francisco,  
Cal., U.S.A.
- Boileau, John A., Chermside Nth,  
Queens., Australia.
- Borg, Raine, Helsinki, Finland.
- Bouch, Nancy E., Franklin, N.C.,  
U.S.A.
- Brandenburg, W. M., Schoonhoven,  
Holland.
- Bromley, Ivy May, London.
- Brown, Hartley R., London.
- Burford, Murray Lyle, Toronto, Ont.,  
Canada.
- Carmichael, Michael L., Castle  
Donington.
- Clarke, Michael D. H., Kirchzarten,  
W. Germany.
- Collett, Jessica M. F., London.
- Cornelius, Richard A., London.
- Cooper, Roy, Disley.
- Dale, Christopher M., Bordon.
- Darragh, Peter J., Wembley,  
W. Australia.
- Davis, Frederick W., Chislehurst.
- Daws, Bernard Stephen, Worcester  
Park.
- De Silva, G. P. M., Singapore.
- Dominguez, Joseph, Carcassonne,  
France.
- Ekanayake, Wilmot J. E., Colombo,  
Sri Lanka.

Eliahoo, Miriam F. M., London.  
 Fava, Ralph M., Paterson, N.J., U.S.A.  
 Giercke, Nicolaus, Hamburg, Germany.  
 Grelick, Gary R., New York, U.S.A.  
 Haraguchi, Yozo, Fukuoka City, Japan.  
 Hayes, Martine N., London.  
 Hill, Anthony C., Blackpool.  
 Holness, Malcolm H., Effingham.  
 Hughes, John S., Reigate.  
 Karasik, Morris, Downsview, Ont., Canada.  
 Kelham, Heather M., Bromley.  
 Kern, Anita, London.  
 Kleiner, Peter H., London.  
 Kryslar, Clement, London.  
 Lewis, Leonard R., Bristol.  
 Li, Sheung Shun, Hong Kong.  
 Locke, Frank, London.  
 Lopez Gutierrez, Luis, Mexico.  
 Malamed, Mervyn R., Cape Town, S. Africa.  
 Margel, Guy, Antwerp, Belgium.  
 Mayer, Maurice, Parkview, Transvaal, S. Africa.  
 Meek, Kerrie, Vancouver, B.C., Canada.  
 Mitchell, Joyce P., London.  
 Molten, Camille P., Richmond, Va, U.S.A.  
 Moses, Heather, London.  
 Nakase, Akio, Tokyo, Japan.  
 Obolewicz, Nicholas A. W., Norwich.  
 Patel, Natakorbhai P., Nairobi, Kenya.  
 Peace, Reginald J., Beverley.  
 Pender, Harold, Kenilworth.  
 Phillipe, Waveney M., Georgetown, Guyana.  
 Quispe, Vicente R., Lima, Peru.  
 Read, John V., Randburg, S. Africa.  
 Richards, Rolph, London.  
 Ridge, James B., Kidderminster.  
 Sato, Takayuki, Tokyo, Japan.  
 Scavia, Fulvio, Milan, Italy.  
 Shafi, But M., Bombay, India.  
 Smith, Martin, Johannesburg, S. Africa.  
 Stabback, Frederick L., Hoylake.  
 Studholme, Geoffrey W. J., Longniddry.  
 Sugihashi, Fumiaki, Tokyo, Japan.  
 Tani, Tooru, Tokyo, Japan.  
 Takasawa, Mitsugu, Tokyo, Japan.  
 Taylor, Marguarita, Pittenweem.  
 Vasen, Emil P., St. Albans.  
 Wratten, Lynnette K., Bexhill-on-Sea.  
 Zoppi, Marco, Flims-Dorf, Switzerland.

#### CORRIGENDA

On page 186 *ante* in lines 4–5 for “rich in copper but not in zinc” read “rich in zinc but not in copper” and in line 6 for “an yttrium copper” read “an yttrium copper analogue of prosopite”. On page 235 *ante* in lines 2–3 for “the Mountains” read “the Cascade Mountains”.

Vol. XIV  
No. 6  
April, 1975

# C O N T E N T S

<b>Twenty-Five Years</b> .. .. .	<i>B. W. Anderson</i>	<b>p.257</b>
<b>Inclusions in Gem Almandine from Idaho and New York</b>	<i>P. J. Dunn</i>	<b>p.273</b>
<b>Report on a New Electronic Refractometer</b>	<i>R. Webster</i>	<b>p.281</b>
<b>Stained Walrus Ivory</b>	<i>E. A. Jobbins and P. M. Statham</i>	<b>p.288</b>
<b>Large Asian Yellow Cat's-Eyes</b> ..	<i>H. L. MacLeod</i>	<b>p.292</b>
<b>Gemmological Abstracts</b> .. .. .		<b>p.293</b>
<b>Book Reviews</b> .. .. .		<b>p.298</b>
<b>ASSOCIATION NOTICES</b> .. .. .		<b>p.301</b>

---

