

Vol. XVII No. 2

April, 1980

THE JOURNAL OF GEMMOLOGY

and

PROCEEDINGS OF THE
GEMMOLOGICAL
ASSOCIATION
OF GREAT BRITAIN



GEMMOLOGICAL ASSOCIATION
OF GREAT BRITAIN

SAINT DUNSTAN'S HOUSE, CAREY LANE
LONDON, EC2V 8AB

GEMMOLOGICAL ASSOCIATION OF GREAT BRITAIN

OFFICERS AND COUNCIL

President: Sir Frank Claringbull, Ph.D., F.Inst.P., F.G.S.

Vice-Presidents: B. W. Anderson, B.Sc., F.G.A.

Norman Harper, F.G.A.

Chairman: D. N. King, F.G.A.

Vice-Chairman: D. J. Callaghan, F.G.A.

Treasurer: F. E. Lawson Clarke, F.G.A.

Fellows elected to Council:

E. Bruton

M. Carr

L. Cole

P. Daly

N. Deeks

A. E. Farn

D. Frampton

A. J. French

S. Hiscox

A. Hodgkinson

D. Inkersole

B. Jones

D. G. Kent

D. M. Larcher

M. J. O'Donoghue,

M.A., F.G.S.

P. W. T. Riley

A. Round

C. Winter

Branch Chairmen:

Midlands Branch: C. L. Hundy, F.G.A.

North-West Branch: M. P. Gayton, F.G.A.

South Yorkshire & District Branch: M. W. Eldridge, M.B., Ch.B., F.G.A.

Examiners:

B. W. Anderson, B.Sc., F.G.A.

A. J. Allnutt, M.Sc., Ph.D., F.G.A.

E. A. Jobbins, B.Sc., F.G.A.

J. M. Bosch-Figueroa, D.Sc.

T. A. Mikkola, L.Phil., F.G.A.

J. R. H. Chisholm, M.A., F.G.A.

H. J. Milledge, D.Sc.

G. H. Jones, B.Sc., Ph.D., F.G.A.

M. Font-Altaba, D.Sc.

M. Virkkunen, M.Phil., F.G.A.

Instructors:

V. Hinton, F.G.A.

P. A. Waters, F.G.A.

D. Pratt, F.G.A.

F. A. Fryer, B.Sc., F.G.A.

S. B. Nikon Cooper, B.D., F.G.A.

J. Edwards, F.G.A.

H. Muller, M.Sc., F.G.A.

H. J. Whitehead, F.G.A.

Editor: J. R. H. Chisholm, M.A., F.G.A.

Editorial Assistant: M. A. Burland

Secretary: H. Wheeler, F.G.A.

Assistant Secretary: D. Wheeler, F.G.A.

Saint Dunstan's House, Carey Lane, London EC2V 8AB

(By Goldsmiths' Hall)

Telephone: 01-606 5025

THE JOURNAL OF GEMMOLOGY

AND PROCEEDINGS OF THE
GEMMOLOGICAL ASSOCIATION
OF GREAT BRITAIN

Vol. XVII No. 2

APRIL, 1980

NOTES FROM THE LABORATORY

By A. E. FARN, F.G.A.

The Gem Testing Laboratory, London Chamber of Commerce and Industry

1. A STONE COLD CERT

The late Professor Tolansky, famous for many things, one of them being his dictum that the only rule which can be applied to diamonds is that they are all different, is followed by Dr Gordon Davies, scientist at the Wheatstone Physics Laboratory, King's College, Strand, who agrees basically but does put them into broad categories in his book *The Chemistry and Physics of Carbon* (Vol. 13, 'Optical properties of diamond').

Most of us know that, whilst diamond is a singularly pure substance having very little impurity indeed, that impurity when present is nitrogen. Diamond is unique in its simplicity of chemical composition, hardness and rarity. We all know, from facts recorded in articles, books and films upon the subject, what great expenditure goes to produce 1 carat of gem diamond—probably paralleled only by the enormous output of oysters necessary to produce one round unblemished pearl of fine orient. Millions of

oysters are destroyed annually by predators (starfish). Most oysters do not produce a pearl at all: those that do, produce a poor-coloured thing of irregular shape. One can see that rarity is indeed an aspect of a gemstone, be it pearl or even diamond.

Diamonds to the lay public mean wealth, glamour and all the trappings which go with wealth and glamour. The public at least know of diamonds and of the consequent value as a status symbol of having one as big as possible (or as your friendly tax man will allow!).

Because of the constant advertising of diamonds being the jeweller's best friend, one-upmanship inevitably follows in achieving even bigger, better and cleaner diamonds for the public to buy; and the demand is for a certificate. There seems to be a sort of magic about the possession of a piece of paper which states degrees of purity and colour. This sort of certification of diamond, however, is *not* gemmology; it is rather a skill acquired by the constant handling and examination in good lighting conditions of one only variety of gem, namely colourless diamond. There is no doubt at all about the absolute skills of some diamond graders. They can see with a $10\times$ lens such minute imperfections that even when they are pointed out and carefully indicated for me I can seldom find them immediately. I have had some very salutary lessons at the hands of these highly skilled people and am left in no doubt that this is a very particular skill indeed and not easily acquired.

This demand for cleanliness, clarity and certification (now termed the three Cs by A. E. Farn) is an increasing symptom of modern demand. Diamonds are always news, particularly large ones, preferably colourless or of a distinct colour.

That imitation is a form of flattery is another oddly apt phrase when considering the gem world. Returning but briefly to pearls, the imitation of real pearls by cultured pearls for a time spoiled the pearl market, but pearls eventually (certainly today) have regained lost ground, because of (possibly) inflation, shortage of cultured pearls due to contaminated waters, etc., and a desire by newly rich people to acquire something rare and natural.

In a like manner diamonds have attracted the synthesizers and the 'improvers'. Laser drilling to remove black spots and bombardment in atomic piles to impart colour are two aspects now faced by the gemmologist in the laboratory. Not too long ago a yellow diamond or a brown diamond was very difficult to sell. When

irradiation was more or less successfully achieved *circa* the 1950s, stronger, harder, colours were produced, and from then onwards (apart from radium-treated stones) we were faced with the detection of treatment in coloured diamonds.

The basis of modern gem testing was firmly laid by the work of B. W. Anderson and C. J. Payne in their early pioneering days, very shortly after the slump years around 1927-31. Until then it is amazing to realize that no precise measurement in Ångström units had been published of gemstones with the exception of the letter from Professor (then, not yet Sir) A. H. Church in 1866 to the editor of the *Intellectual Observer**, upon his findings in the examination of pleochroic minerals and salts. In this Church mentioned seven bands seen in zircons colourless and coloured, heat-treated and natural, as well as the bands seen in almandine garnet. Strangely, he never followed it up, probably being fully engaged upon other activities. The use and *method of use* of the spectroscope, e.g. the attainment of a decisive spectrum in a ruby in gem testing, was first postulated by C. J. Payne, who partnered B. W. Anderson in those early formative days. Practically every gem absorption-spectrum measurement we rely upon today stemmed from the work of these two early gemmologists, who were both qualified scientists as well. There can never be sufficient praise and appreciation by us ordinary gemmologists for the foundations so well and truly laid by these two English pioneers. In this changing shrinking world it is good to look back and take the opportunity in *Notes from the Laboratory* to say again 'Thank you for your work'.

As the new technique of neutron bombardment in an atomic pile and the subsequent annealing by heat of the irradiated stones produced exciting new colours, so the demands grew for such stones. Where there is a lot of money represented in a very small article, so the temptation to obtain some of it opens the path of chicanery and deceit. So too forms the queue to have stones tested and certified—this time the emphasis of the three Cs is on *cleanliness*, and *colour certification*—and the *colour*, is it natural?

We have known for many years that, in brief, the irradiation of diamond and its subsequent annealing causes damage, the damage being signposted by a line at 5920Å, sometimes accompanied by lines at 4980/5040 with 'Cape series' lines at 4780

*Micro spectroscope investigations, *Intellectual Observer*, 1866, 9, 292.—Ed.

and 4155Å. We have known from examination of these lines (in our laboratory and others) that heat at room temperature increased by transmission of light through a diamond undergoing spectroscopic examination drives off the faint but distinct line at 5920Å. In our laboratory B. W. Anderson tried many times to restore/sharpen this fugitive line by cooling the diamond. Given time we would leave a diamond in the safe overnight, come into the lab in the morning with fresh eyesight, rig up the spectroscope and our 500 watt lighting and look quickly to find the line. Usually B. W. A. spotted most quickly: he was uncannily perceptive in the blue end of the spectrum, as well as at 6500-6800Å. He tried purchasing frozen carbon monoxide and carried it in a brief case all frosted up by taxi to our laboratory. We never did get good results, due to insufficiently low temperature, inadequate insulation and lack of technique and know-how on this side (the cold side), and insufficient funds. Kenneth Scarratt has already written of our later achievement of low-temperature spectroscopic examinations (J. Gemm., 1979, XVI (7), 433-47) and these notes are merely by way of filling in some background details.

Much was written by B. W. Anderson on the classification of diamond and upon line systems in the fluorescence spectra of diamond (J. Gemm., 1962, VIII (5), 193-202, and 1963, IX (2), 44-54). When he retired in 1971, we had a fair understanding of the nature of treated diamonds and the characteristics to look for. Equally, thanks to his early endeavours we enjoy a very strong accord with other world-wide laboratories and exchange notes and information for mutual protection. There have been cases in recent history of coloured diamonds being variously described by experts. Some, of course, are genuine mistakes, due to lack of experience: others we fear can be less happily explained. We have been continually aware of this and not entirely happy at times when we have *not* issued a certificate due to questionable interpretation of the characteristics of a diamond as far as we could obtain them with the facilities then at our disposal.

Fortunately for us we established a happy relationship with workers researching irradiation damage in diamond and made contact with them at University of London King's College (Strand). Their method of cooling diamond was copied by us with their assistance in a fairly simple form. Basically it is a Dewar (thermos) flask holding 25 litres of liquid nitrogen, which is turned into gas by

a 'boil off' system. The cold gas flows through insulated flexible tubing to cool the diamond mounted on a special holder in a vacuum tube—this prevents frost occurring on the diamond, which could impede light transmission. The whole system is built on an optical bench to facilitate focusing in line. One end constitutes a cold light (halogen) light-source and heat shield, with a warm-up rheostat built in to avoid surge. Through a lens the light is focused onto and through the girdle of the diamond, table facet parallel to floor. The emergent light is focused again by an equidistant second lens onto the slit of a Beck 2458 prism spectroscope clamped in line at the far end of the optical train.

This added refinement to gem testing is a most useful addition in the continuing struggle by the gemmologist for truth. We have positive proof in cases of evanescent 5920 lines at room temperature in treated diamonds becoming fine sharp and clear thus proving 100% conclusively a treated stone.

There have in the past year been articles in newspapers based on extracts from erudite papers (quoted out of context) by scientists publishing their new findings, and undoubtedly there will be an occasional treated diamond which causes trouble, but I would think that 99% of treated stones tested will be proved beyond doubt: of the small remaining portion of 1%, I should imagine that most will be detected by cooling methods and, failing that, a print-out chart from an infrared photospectrometer. Despite the heat generated by some diamond dealers' reactions on reading scare headlines in the daily press (and I have suffered their vociferous protestations), I would say that our advice to them is—'Cool it!'

[Manuscript received August, 1978: revised October, 1979]*

2. THE LENNIX SYNTHETIC EMERALD

Quite early in 1979 I was paid a courtesy visit by the husband of Mrs C. Bartolo, F.G.A., of Rhodesia. I was shown some small green crystals said to be a new synthetic emerald currently manufactured by a friend, who is a chemical engineer, prospector and something of a mineralogist. Would I like to examine them?

*Although received in 1978 it was most unfortunately mislaid and was slightly adapted for its long-delayed publication.—Ed.

They were offered as specimens for the Laboratory collection. I was both pleased to have them and grateful that we were considered of sufficient merit to warrant the gift and the information. My contacts with fellow gemmologists in Rhodesia have been most cordial since we understand now the position of chromium as a criterion for emerald, and an accord has developed from this matter.

At international gemmological conferences we have had very interesting résumés of the mining and prospecting scenes in both South Africa and Rhodesia by their geologists. The names of the adjoining regions being synonymous to me with rubies, emeralds, grossular garnets, tanzanite, etc., a new *synthetic* emerald emanating from that source seemed unusual, to say the least. In the past I was asked by the editor of the then popular monthly, *The Gemmologist*, to write a series on Verneuil synthetics and the then new to us Carroll Chatham synthetic emerald. I replied that it had all been done before very competently by my own colleagues, B. W. Anderson and Robert Webster. I was told it would always be new and news to some, and that not every budding gemmologist read B. W. Anderson or R. Webster. So let us hope that familiarity has not bred contempt and that some gemmologists will find interest in the details of this new synthetic emerald.

I have not grown blasé towards practical gemmology despite many years of practical application. Because of the many changes taking place in our Laboratory whether of staff, venue, outlook, commitments, etc., I find myself less and less involved in actual practical gemmology except for pearls. I decided to do some gemmology for a change—at least that *was* my intention. Which brings me to the end of this preamble, and a suggestion that above my paper- and pearl-strewn workbench I should have a sampler suitably sewn. It should read 'The road to Hell is paved with good intentions.' Last June I started work on the Lennix stones! (Today is 31.1.1980).

The first thing that struck me about the stones was that they were individual small shapes rather like preformed crystals of tabular habit. They had smaller crystals jutting out haphazardly but not in quantity, rather like a few eruptions or pimples.

I used a 10× lens as my first tool in the examination. I find it quite a challenge to see things with a 10× lens for the first time. I try to establish characteristics, whether surface structures such as

low viscinal faces, striations, double refraction, dichroism, etc., before full testing. Perhaps I should have started off to say that the name of the manufacturer is L. Lens, of France, hence the name for his synthetic emerald *Lennix*. In his correspondence, M. Lens has asked if possible that the details should be published in the *Journal of Gemmology*. A compliment to our *Journal*—I wish I had been able to be speedier in my presentation.

M. Lens is understandingly reticent upon some details of his method of manufacture for commercial reasons, but he states definitely that the growth is by flux fusion, very similar he says to Carroll Chatham and Pierre Gilson. He states, 'One peculiar feature that you will note on the enclosed sample is that while the natural facets of the hexagonal crystal can be easily seen, the general outline of the crystal is rather square or rectangular with cut corners. This is done intentionally by a process I developed, whereby (although crystallizing in the normal hexagonal system) the crystals are forced to adopt these external shapes. This is of great advantage to the lapidary and buyer of rough material, because the usual hexagonal shape of natural crystals is far from being the most advantageous from the point of view of recovery in cut stones. On the contrary, with this synthetic material the stones are 'pre-shaped', which results in the minimum of labour for cutting and the minimum of waste.'

M. Lens continues as follows:

'I thought you might be interested in some background on the research that has been involved. It all started in 1954, when I came across an article in the French edition of the *Readers Digest*, dealing with different achievements in the manufacture of synthetic crystals, and more specially with the work of Chatham. That article was in fact an abstract of a publication in the U.S.A. magazine *Fortune*, no. 42, August 1950, of which I have been able to obtain a copy recently.

'At that time, I was established in ex-Belgian Congo (today Zaïre) and engaged in mining and prospecting with a mining company. I had always had some interest in gemstones, but my work there was much more prosaic and dealt only with tin and tungsten ores. Since I had qualifications as a chemical engineer, and already some experience in mineralogy, the results obtained by Chatham appeared to me as a challenge, and I decided then that to achieve a similar result would be my main hobby. Of course, life in

the middle of the African bush is far from offering the ideal condition for a research work of that kind! Nevertheless, I did not despair, and still managed for some years to do a little work on my 'hobby', sometimes under the most hectic conditions of improvisation. No need to say, I did not reach any positive result at that time.

'Fortunately, I had in 1960 the opportunity to leave the Congo and to establish myself in Johannesburg, South Africa, where I joined the Diamond Research Laboratory, a branch of the Anglo-American Corporation. In addition to being a most interesting job, it gave me access to scientific libraries and to a lot of priceless information. Also I could this time continue on my personal project under much better conditions. It took until 1966 before eventually I could obtain some positive result. Nothing yet very exciting indeed: in the residues of a test run, I at long last spotted some greenish crystals. They could be seen only under the microscope at high magnification, were poorly crystallized, and lacked transparency. Very difficult conditions for an accurate identification!

'These tests were repeated numerous times, under different conditions, until eventually I could produce crystals, still of very poor quality, about $\frac{1}{2}$ mm long. That was sufficient to have a determination of SG and refractive index which confirmed that the crystals were beryl. From then on, work has been continued, with very slow but constant progress, up to the latest samples that you have now.

'I feel that more progress still can be done, mostly on the clarity and freedom from defects, and I am still continuing in that direction. So far I have done since the beginning over 8000 runs. . . .'

Proceeding with my tests on the Lennix synthetic emerald, I found it salutary to find my several densities by hydrostatic method to be consistent in result, but consistently low and slightly wrong! Over a series of weighings I had an average density of 2.6409 on specimens averaging 0.607 ct—1.465 ct. To check myself, the balance and the ethylene dibromide, I took a large clear quartz polished piece used by B.W. Anderson as a check on the density of liquids and found the density to be 2.651, which proved the liquid (ethylene dibromide, or dibromoethane if you prefer it) to be correct. The simple aspect of gemmology was to make a new suspension liquid of bromoform and bromonaphthalene with a

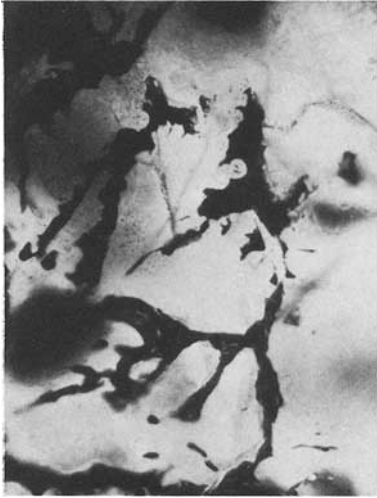

FIG. 1. Flux inclusions



FIG. 2. Three-phase inclusions

in Lennix synthetic emerald.



FIG. 3. Two-phase feathers



FIG. 4. Two-phase inclusions

in Lennix synthetic emerald.

doubly terminated Herkimer ordinary quartz crystal finely suspended (very enjoyable). Having obtained this tube of liquid of *known* density I placed in eight specimens of Lennix synthetic emerald. They clustered around, slightly above and slightly below the quartz in suspension, offering a density range of 2.650-2.6515.

I employed a further refinement and enjoyed further pleasure by slightly warming the tube in front of and close to a 60-watt bench lamp. This caused them all to sink in a dignified manner and to recover their poise as the liquid cooled. In fact they behaved as good party members of the quartz group (density branch) exhibiting solidarity with the party leader (Herkimer) and practising their disciplined party piece of 'one up all up', 'one down all down'.

All the Lennix specimens were a very strong glowing coal ember red when viewed through the Chelsea filter. Under long wave ultraviolet light they all had a reddish glow, under short wave ultraviolet (SWUV) they were a lesser more orange red. Under x-ray excitation they were a dull but distinct red. One of the useful tests for synthetic emerald, published long ago in the old *Gemmologist*, is the transparency to SWUV light of synthetic emerald*, whereas natural emeralds are opaque to SWUV. My tests in this manner were somewhat inconclusive (probably due to heavily included material). I appeared to have some opaque to SWUV among the synthetics and a transparent among the natural stones I had borrowed! Fortunately we had polished 'flats' on two specimens and were able to obtain results showing low refractive indices and small birefringence. In fact the low 'text book' SG, RI and fierce red under Chelsea filter plus red glow under long wave ultraviolet light are themselves sufficiently diagnostic.

The photographs of inclusions, feathers, etc. are by K. V. Scarratt, and the exteriors of the single crystals showing protrusions are by R. K. Mitchell. I am indebted to Mr and Mrs Bartolo for their gift to the laboratory and to M. Lens for interesting details of his experiments.

The Lennix synthetics should not deceive the gemmologist, since they are marketed as synthetics, and as we have been given long and full details by M. Lens we should be able to tell them when they arrive (hopefully) at our Laboratory door—even if they are in an antique mount!

*Anderson, B. W. A new test for synthetic emerald, *Gemmologist*, XXII (264), 115-17 (1953); *Gem Testing*, 8th edn, pp.86, 101. London, Butterworths (1971).

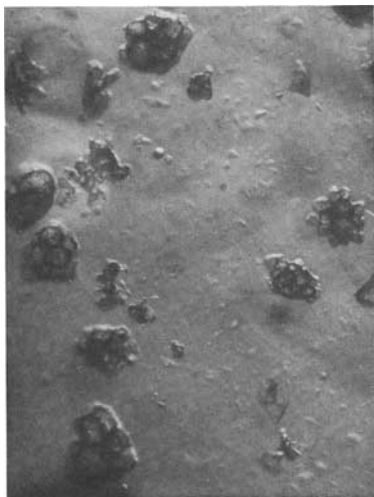

FIG. 5. Crystal groups

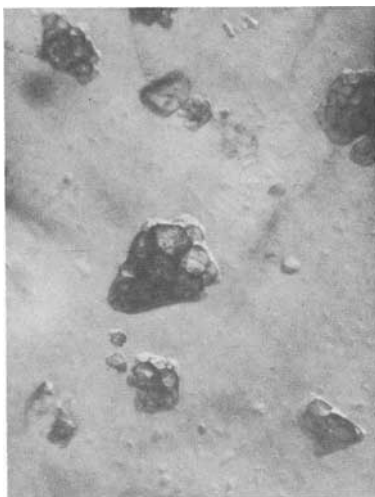

FIG. 6. Crystal aggregates

in Lennix synthetic emerald.

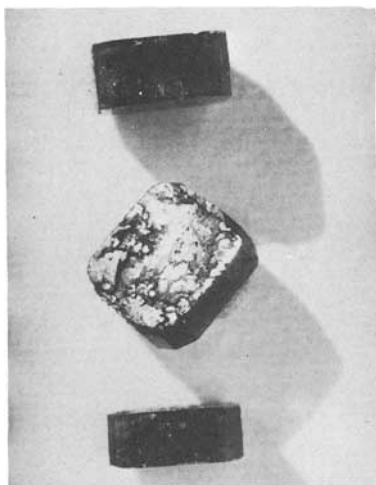

FIG. 7. Exterior of Lennix synthetic emerald crystals.



FIG. 8. Crystals on surface of Lennix synthetic emerald.

SUMMARY

LENNIX SYNTHETIC EMERALDS

A fierce red viewed through the Chelsea Filter.

Red under *long wave* ultraviolet light.

Orangy-red under short wave ultraviolet light.

Refractive Indices 1.562 to 1.566.

Birefringence *small* 0.004.

Specific Gravity 2.65 (quartz matching liquid).

Absorption Spectrum a strong chromium spectrum which is not diagnostic for distinguishing natural from synthetic emerald.

Although fluorescence is useful as a back-up test, it must not be 'leaned upon' for support.

I have noticed that most *natural* emeralds are green or inert under LWUV, but this is not a rule.

[*Manuscript received 9th February, 1980.*]

AN OPAL IMITATION MADE FROM LATEX

By MICHAEL J. O'DONOGHUE, M.A., F.G.S., F.G.A.

Through the kindness of Dr Achira Kose, Institute of Applied Optics, Tokyo, Japan, I have been able to examine two pieces of an opal imitation made from a monodisperse polystyrene latex. Both stones are cut en cabochon; both have a play of colour against a white background and both show a much less regular pattern of colour patches than the opal manufactured by Gilson. Both stones appear to be quite hard and neither was porous—at least there appeared to be no effect when the stones were briefly immersed in methylene iodide. Under long wave ultraviolet light there was a

weak whitish luminescence. Microscopic examination ($20\times$ and $30\times$) showed quite clearly, in both stones, markings resembling streaks made by a paint brush moved unevenly. These dark markings were not confined to any particular patch of colour but extended over a number of the patches. I have seen no such effect in natural opal nor in the Gilson product; the hexagonal markings seen in the colour patches in Gilson opal were quite absent here. At present it looks as though these markings provide the best clue to the identity of the material, though it should be stressed that with only two stones examined further features may later come to light.

Monodisperse means simply that there is a constant value of the sedimentation coefficient for successive time intervals of growth; the polystyrene latex showed iridescence when sodium polyacrylate was added to it, the iridescence appearing on the surface of the test tube as well as on the subsided sediment.⁽¹⁾ Since the iridescence shows that there must be a regular structure in the tube the affinity with the structure of precious opal is apparent. The process of coagulating the particles into the aggregates which display iridescence is known as 'flocculation' and the aggregate itself as a 'floc'. It was noted⁽¹⁾ that during growth the standard particles were green and that other colours, in particular yellow and orange, were seen when impurity particles of larger size appeared toward the surfaces of the crystallites.

It is fair to say that even without a lens the stones arouse faint suspicion on account of a tendency towards glassiness; in this they have a slight resemblance to the Gilson product. The play of colour appears to begin perceptibly below the surface and at some angles a sheet of colour (blue and green in this case) appears to flood the whole stone. By transmitted light there is a light yellow colour, quite like that seen in other manufactured and in natural opals.

REFERENCE

1. Kose, A., Hachisu, S. Ordered structure in weakly flocculated monodisperse latex. *Journal of Colloid and Interface Science*, **55** (3), 487-98, 1976.

[Manuscript received 15th October, 1979.]

TWO REPORTS:
(1) ALTERNATIVE REFRACTOMETER
LIGHT SOURCES:
(2) THERMAL DIAMOND PROBES

By PETER G. READ, C.Eng., F.G.A.

(1) ALTERNATIVE REFRACTOMETER LIGHT SOURCES

A monochromatic light source centred on 589.3nm is an essential requirement for the precise measurement of refractive indices when using a critical angle refractometer. This is particularly the case if there is an appreciable difference between the dispersion of the measuring prism and that of the gemstone under test, as this results in the production of a 'rainbow' fringe to the shadow edge when using a polychromatic light source.

Unfortunately, the production of yellow light at 589.3nm by means of a sodium lamp can be expensive. This is because a lamp of the size convenient for gemmological use has a very limited market and is therefore only produced in small, and correspondingly expensive, batch quantities.

Alternatives to the sodium lamp include the use of a yellow colour filter either between the light source and the refractometer, or over the refractometer eyepiece. In either case the effective emission spectrum of the light source, while centred on 589.3nm, overlaps into the red and green portion of the spectrum. The high transmission loss through the filter also necessitates the use of a high-intensity light source. If an interference type filter is used (as in the latest version of the Krüss ER60 refractometer) this results in a much closer approximation to a monochromatic light source, but because of its narrow pass-band it also requires a high-intensity light source.

A separate refractometer light source, using a quartz-halogen lamp and an interference filter, has been marketed by Orwin Products Ltd, and is called the 'Monolite' (Figure 1). This unit uses an optical system which can be adjusted in height to suit all makes of refractometer. The transmission response of the filter has a bandpass which is centred on 589.3nm, cuts off sharply at the yellow/green boundary and tails off slightly into the red.



FIG. 1. The 'Monolite' with a Dialdex refractometer.

In a recent letter* to Mr J. R. H. Chisholm, Mr D. Minster† (of Pretoria, South Africa) proposed the use of yellow light-emitting diodes (LEDs) as an alternative light source for the refractometer. His test, using a Beck wavelength spectroscopy Type 2522, indicated that the LEDs had a peak emission very close to that of the dominant sodium line and an emission bandwidth of 550-640nm. In a battery-powered unit incorporating six yellow LEDs, constructed by Mr Minster, the LEDs were mounted in an array which fitted the light entry port of his Rayner Dialdex refractometer.

With Mr Minster's approval, Mr Chisholm submitted his letter to me and asked me to test and report on the proposal. Accordingly I obtained a supply of yellow LEDs (Vitality, type CM4-582B) and checked their emission spectra with the aid of a Jena wavelength spectroscopy. The LEDs were of the high-brightness GaAsP/GaP type with internal luminized reflectors. Their emission peak was centred on 585nm, with a bandwidth extending from 560-640nm, the latter corresponding closely to the measured transmission response of the Rayner eyepiece filter.

*Posted 5th July, 1979.—Ed.

†Now F.G.A. (D. 1979).—Ed.

The electrical characteristics of LEDs are more variable than those of filament lamps, and for this reason it is difficult to operate them satisfactorily when connected in series. Because of this, D. Minster powered his six LEDs by connecting them in parallel (via individual current-limiting resistors) to a 9-volt battery. While this makes a useful portable unit, the battery current is in the region of 120-200mA, and I considered it more satisfactory to construct a mains-powered unit for evaluation purposes using a bell transformer (see Figures 2 and 3).

I made tests using this LED light source on a Rayner Dialdex refractometer, with a range of gemstones having a dispersion from 0.007 to 0.027. In all cases the shadow edge, while not as sharply defined as with the sodium light source or as bright as with the 'Monolite', was as clear as that obtained with the Rayner eyepiece filter when used with a high-intensity lamp. The cost of the various components was not high, and by choosing a Klingel 4-volt 1-amp bell transformer it was possible to mount the LEDs on the plastic transformer housing. An external mains lead clamp was added as a safety precaution.

The Rayner Optical Company is currently developing a mains-powered LED light source to provide a low cost alternative to their existing sodium lamp unit. This, like the 'Monolite', will be available from Gemmological Instruments Ltd.

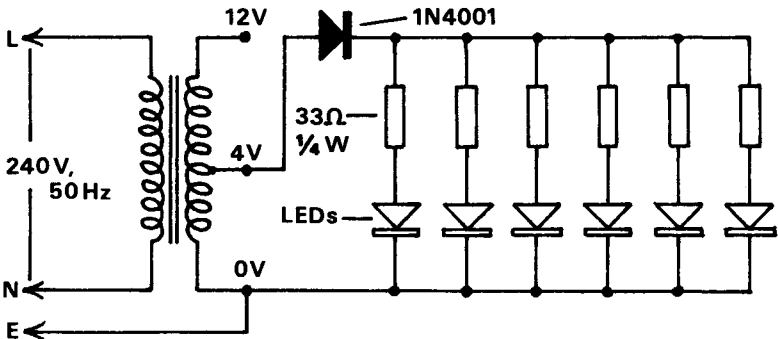

FIG. 2. Circuit diagram of mains-powered LED unit.

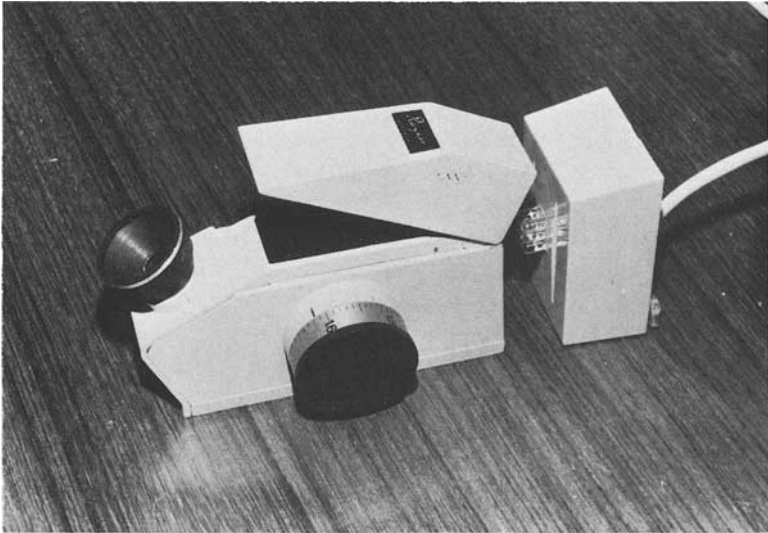

FIG. 3. Unit positioned for use with a Dialdex refractometer. The LEDs are mounted on the plastic case of the bell transformer. The associated rectifier and resistors are mounted inside the case.

(2) THERMAL DIAMOND PROBES

The introduction of a commercial gem-testing instrument using a virtually unexploited phenomenon is a rare and interesting event. Over the last four years the only items of equipment in this category have been the reflectivity meter, the GIA Gem Diamond Pen, and the Ceres Diamond Probe, each of which uses a different and unique gemstone property as an aid to identification.

The reflectivity meter (now manufactured by six firms in the U.S.A., Australia, Japan and Italy) identifies gemstones by measuring their relative reflectivities or lustres. This type of instrument is particularly useful for checking diamond and those diamond simulants whose RI is above the range of the standard critical-angle refractometer. However, it cannot be regarded as a precision instrument, and misleading readings can sometimes be produced by internal reflections and dirty or scratched facets:⁽¹⁾

The GIA Gem Diamond Pen⁽²⁾ uses the low water-contact angle of diamond to distinguish it from its simulants. In use, the pen dispenses a special 'ink' which flows relatively easily on the

surface of diamond but breaks up into droplets on all of the high RI diamond simulants. As this test can sometimes be invalidated by the presence of thin surface coatings, which cause a simulant to react in the same way as a diamond, it is necessary for the table facet of the stone under test to be rigorously cleaned (using a 'soft' polishing powder provided with the kit).

Both reflectivity and liquid-flow tests can be difficult with small stones, the practical lower limit being a stone having a 2-3mm girdle diameter (i.e. a 20-50 point diamond). Furthermore, if the mounting claws of a ring-set stone are above the plane of the table facet, it is only possible to obtain a reflectivity reading on those instruments which have either a recessed groove to accommodate the claws, or a raised rim surrounding the test aperture!⁽³⁾ If the stone is recessed in its mounting, it becomes impossible to take a reading, even on instruments which make provision for claw settings. It is in these situations where the Ceres Diamond Probe can be particularly useful in distinguishing diamond from its simulants.

The prototype of the Ceres Diamond Probe was first made available for evaluation in 1978!⁽⁴⁾ Since then several improvements have been made, and these have been incorporated into the production model which was tested for this report.

The instrument (Figure 4) is a thermal conductivity comparator, and comprises a control/indicator unit and a test probe. The thermal conductivity of diamond is unusually high* and it is this property which is used by the instrument to distinguish diamond from its simulants.†

The test probe contains a copper tip linked to two very small bead-type thermistors (i.e. ceramic elements whose resistance varies with temperature). One of these thermistors is fed with pulses of current at one second intervals, and acts as a miniature heater. The other thermistor is used as a thermal sensor, and its resistance is measured to indicate the temperature of the copper tip of the probe.

When the probe is not in contact with any other material, the temperature of its tip rises a few degrees above ambient because very little heat is being conducted away from it. However, if the tip is pressed against a diamond, each short pulse of heat is conducted

*Typically 1500 Watts/m°C for Type I diamond, compared to 400 Watts/m°C for copper (at room temperature).

†The same property is used in the 'breath' test, where the rapid dispersion of moisture from the surface of a diamond acts as an indicator.



FIG. 4. The Ceres Diamond Probe. On the left of the vertical front panel is the socket for the battery charger and below it the battery warning lamp. (These may be seen better in Fig. 9—but on the right, as the panel is inverted.)

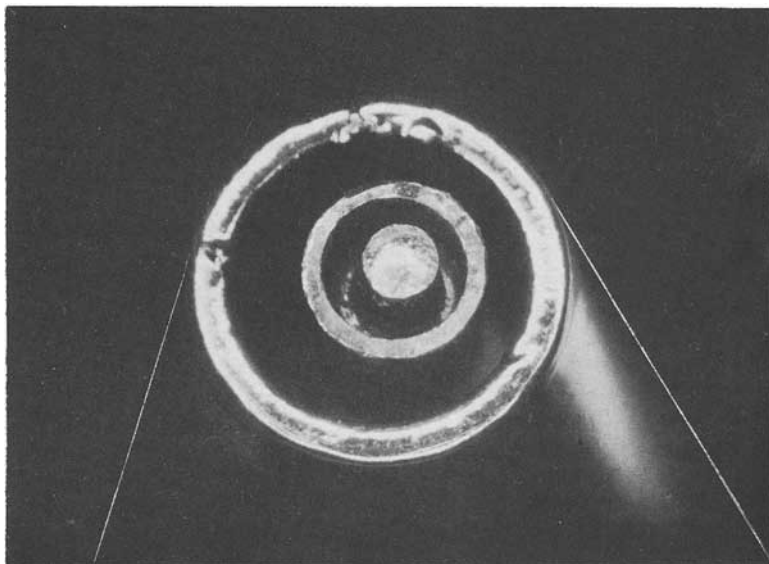

FIG. 5. View of the 0.5 mm diameter copper tip of the probe with its protective guard ring.

away through the diamond, and the temperature of the tip is not able to rise as high. If the tip is pressed against a poor heat conductor such as glass or cubic zirconium oxide, the tip temperature rises to an intermediate value which is significantly higher than that for diamond.

Because the energy content of the heating pulse is very small and occurs in short pulses separated by one second intervals, even a very small diamond is capable of conducting a significant proportion of the heat away from the probe. The temperature of the probe tip is automatically measured by the instrument at one second intervals. The measurement is 'latched' to produce a steady meter-reading, which is then updated at each successive sampling of the probe temperature.

To protect the probe tip and thermistors from damage, the tip assembly and its concentric metal guard ring (Figure 5) are spring-loaded, and retract under pressure into the body of the probe when the tip is pressed against the surface under test. Because of the small dimensions and low thermal mass of the tip assembly it is possible not only to test stones down to 3 points in size, but also to check stones which are recessed in their mounting.

The instrument's meter scale is marked off into three colour-zones. If the meter needle comes to rest within the broad red zone on the left side of the scale, this indicates that the gem under test is a simulant and not a diamond. If the needle moves across into the green zone at the right of the scale, this indicates that the stone has a high thermal conduction, and is therefore most probably a diamond. A narrow amber 'no identification' zone separates the red and green sections of the scale.

In addition to the meter indication, there are red, green and amber indicator lamps. If the stone is a simulant, the red and amber lamps flash alternately; if a diamond is detected, the amber and green lamps flash. If the meter reading lies in the central amber zone, only the amber light is energized. Although the instrument is capable of testing stones down to 3 points in size, small diamonds (because of their low thermal mass) produce a reading towards the amber end of the green zone, while larger diamonds cause the meter needle to move further into the green zone. With stones having a lower thermal conductivity than diamond, the size of the stone has much less effect on the meter reading.

Two probe test surfaces are provided on the sloping front

panel to allow the instrument's calibration and correct functioning to be checked. The square test surface on the left simulates the thermal conductivity of a mid-range simulant, while the one on the right imitates that of a medium size diamond. A recessed pre-set adjustment is provided in the front vertical panel which allows the calibration of the instrument to be adjusted in conjunction with the test surfaces.

As the instrument is designed to measure very small thermal changes at its probe tip, for best operation it should be used in a constant ambient temperature within the limits of 12-32°C (55-90°F). For the same reason, gemstones which have been in a cold environment must be allowed to warm up to room temperature before being tested. Should the unit be operated outside the specified temperature range, the meter needle will return to the amber zone, and only the amber test lamp will continue to flash.

To check the reliability and range of the instrument, the writer made a series of tests using a variety of natural and synthetic simulants of diamond, together with diamonds of various sizes down to 3 points, and a selection of metals. For convenience of handling, and to achieve comparable conditions, all loose stones were tested in a 4-prong stone holder (hand-holding a stone did not, however, appear to affect results).

Although Type IIa diamonds (as used in heat sinks) would be expected to produce, size-for-size, a larger meter deflection than Type I stones, all diamonds used in the test were unclassified and were assumed to be the normal Cape series combination of Type Ia and Ib material. A summary of the tests is given in Table 1, and Figures 6-8 give an indication of the readings produced during tests on large and small diamonds, and on cubic zirconium oxide.

The overall impression gained from these tests was one of reliability, and once the technique of applying the probe tip at right-angles to the test surface (with just sufficient pressure to cause the tip to retract slightly) was mastered, consistent and repeatable results were obtained down to the specified limit of 3 points. The only problem which occurred was with very small rose-cut diamonds and 'chips' where it was difficult to locate the probe accurately on a usable facet surface.

During a test, it is important that the probe is held in steady contact with the stone for at least three seconds until a constant reading is obtained. This is to allow for two or more successive

TABLE 1

GEM MATERIAL	CLOCKWISE DEFLECTION OF METER NEEDLE†
Diamond (0.75 ct)	9 mm into Green zone
Diamond (0.20 ct)	6 mm into Green zone
Diamond (0.03 ct)	2 mm into Green zone
Colourless Sapphire*	28 mm into Red zone
Colourless Zircon*	22 mm into Red zone
Colourless synthetic Spinel*	16 mm into Red zone
YAG*	12 mm into Red zone
Strontium Titanate*	11 mm into Red zone
Colourless Quartz (10 ct)	10 mm into Red zone
GGG*	10 mm into Red zone
Rutile*	10 mm into Red zone
Lithium Niobate*	6 mm into Red zone
Cubic Zirconium Oxide (2.5 ct)	5 mm into Red zone
Glass*	2 mm into Red zone
Sterling silver (1 oz ingot)	11 mm into Green zone
Aluminium foil	10 mm into Green zone
Krugerrand/24 carat gold	5 mm into Green zone
22 carat ring shank	Amber/Green boundary
9 and 18 carat ring shanks	Red/Amber boundary
Electroplated nickel-silver	Red/Amber boundary
Rolled gold	33 mm into Red zone

*Between 0.5 and 2.0 ct

†Effective length of Red zone = 35 mm

Effective length of Green zone = 15 mm

samplings by the electronic circuits as the probe temperature stabilizes. The manufacturers warn against using too much force on the probe tip, and also state that it should not be moved or wiped across the surface of the gemstone, as this may damage the soft copper tip.

Surface dirt and thin coatings of grease and oil appeared to have no effect on the accuracy of the readings, although in excess these would undoubtedly contaminate the probe. To test the effect of an insulating coating, a 10mm square of aluminium was sprayed with a thin layer of lacquer. The resulting thermal conductivity as measured by the probe was only marginally lower. Before making the tests detailed in Table 1, all samples were cleaned to conform with normal gem-testing practice.



FIG. 6. Testing an 0.75 carat diamond.



FIG. 7. Testing an 0.03 carat diamond.



FIG. 8. Testing a 2.5 carat cubic zirconium oxide.

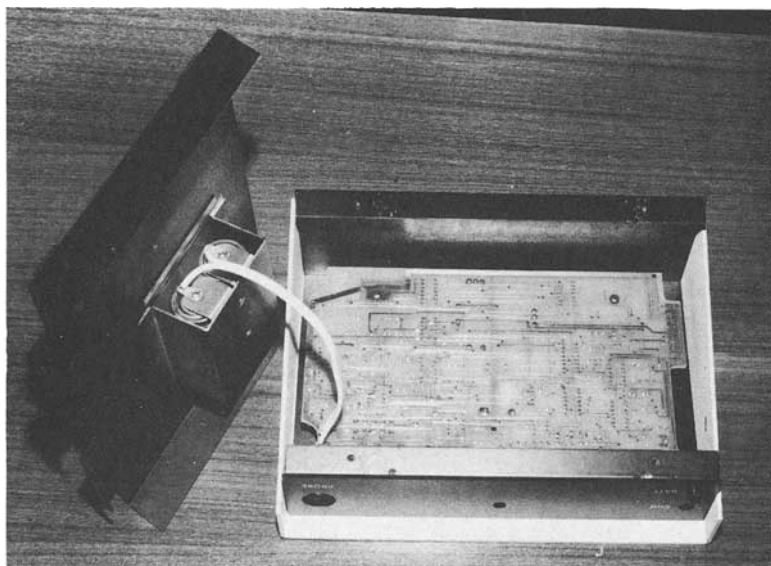

FIG. 9. View of the unit with the base cover/battery holder removed. The electronic components, including twelve integrated circuits, are mounted on the panel side of the large printed-circuit board.

Although no tests were carried out with diamond doublets, these can be expected to produce a 'diamond' reading in the green meter zone (although presumably the deflection would be smaller for a given size than if the stone was 100% diamond). However, if it is possible to make tests on both the crown and pavilion facets of a suspect stone, even this type of 'simulant' can be detected.

The Diamond Probe's electronic components are mounted on a large double-sided printed-circuit board in the control unit (Figure 9), and include twelve integrated circuits. The unit is powered from two 1.2-volt rechargeable nickel-cadmium cells. A separate twin-range (120/240-volt, 50/60 Hz) battery charger is provided, and this can also be used to operate the unit directly from the mains. If the battery voltage falls below a predetermined level, a red battery warning light flashes on the front vertical panel; the instrument will then continue to function accurately for several more minutes before switching itself off (in this condition all the top panel lights are extinguished, and the meter needle returns to the amber zone). The instrument can be operated for 8 to 10 hours from fully charged cells; re-charging time is 14 to 16 hours.

The only maintenance that appears to be necessary concerns the probe tip, which, for reliable readings, must be kept clean and free from dust particles. During tests, the gap between the probe tip and its guard ring tended to collect dust particles, and, although these did not affect the results, the probe tip was cleaned with a fine camel-hair brush between tests. The manufacturers suggest that the probe tip is cleaned by rinsing it in alcohol, and then allowing it to dry out. They also recommend that the tip is polished lightly by wiping it, using a rotary action, on a piece of lint-free paper.

As with the GIA Gem Diamond Pen, the accompanying instruction book carries a warning that test results should be regarded as a strong indication rather than a positive identification of a simulant or a diamond. It should also be remembered that high conductivity metals such as sterling silver and 24 carat gold will produce readings in the green zone (see Table 1). Although gold jewellery settings are usually made from alloy golds, care should still be taken to see that the probe tip is in contact with the surface of the gem and not the metallic mounting. While there are also a few transparent non-diamond materials which could produce readings in the green zone of the meter scale (e.g. silicon carbide, bromellite and cubic boron nitride), these are unlikely to be met

with in jewellery, and are in any case sufficiently different in appearance to prevent them from being confused with diamond.

To summarize, the Ceres Diamond Probe provides a rapid and practical means of distinguishing diamond from its many simulants. Its ability to identify very small diamonds, and diamonds whose table facet is well below the level of the mounting, enables the probe to complement the operation of the reflectivity meter in this respect. However, there are very few tests in gemmology that are 100% confirmative, and results obtained with the instrument should always be checked by means of other techniques such as the inspection of facet edge condition with a hand lens, the 'tilt' test, or, where practical, a reflectivity reading.

The Diamond Probe is manufactured by the Ceres Electronics Corporation, 411 Waverly Oaks Park, Waltham, Mass., 02154, U.S.A. (The parent company, Ceres Corporation, is the American manufacturer of cubic zirconium oxide). The dimensions of the instrument are 230mm × 185mm × 95mm, and its price is approximately \$650, plus freight, duty and VAT.

A much simpler thermal comparator for diamond testing has been developed, in conjunction with the Australian Gemmological Association, by Professor J. Goldsmid of the University of New South Wales. This unit is also battery-powered, and uses a temperature indicating galvanometer and a glass probe containing a heating element. In the U.K., the Rayner Optical Company is developing the 'Rayner Diamond Tester' which also uses the high thermal conductivity of diamond and provides an accept or reject indication on three panel lamps. While more sophisticated than the Australian version, the Rayner model will be considerably less expensive than the Ceres Diamond Probe, and will be marketed through Gemmological Instruments Ltd.

REFERENCES

1. Hanneman, W. *J. Gemm.*, XVI, 2, 109-21, (April 1978).
2. Read, P. G. *J. Gemm.*, XVI, 7, 465-9, (July 1979).
3. Read, P. G. *J. Gemm.*, XVI, 1, 50-4, (Jan. 1978).
4. Nassau, K. *Lapidary Journal*, 32, 1970-3, (Dec. 1978).

[*Manuscripts received 15th September and 22nd October, 1979: revised January, 1980*]

THE GEMMIFEROUS GRAVELS OF THE FRASER AND REDDISTONE CREEKS, INVERELL-GLEN INNES DISTRICT, NEW SOUTH WALES

By PAUL L. BROUGHTON, M.Sc.

Department of Mineral Resources, Regina, Saskatchewan, Canada

ABSTRACT

The gemmiferous gravels associated with the Fraser and Reddistone Creeks in north-eastern New South Wales are the second largest source of commercial sapphire production in Australia. The mining district is centred north-east of Inverell and north-west of Glen Innes. The sapphire, zircon and corundum fraction is extracted from Tertiary buried gravels, which have been partially reworked into the Holocene drainage system. Igneous source of the sapphires is unknown.

The size of the mining operation is dependent upon the width of the alluvium. A 40 to 50 cubic yard daily excavation is typical of the small two man operated leases. These are generally restricted to the narrow entrenched river sections, where filled potholes into irregular bedrock surfaces are excavated with mechanical back-hoes. Wide flood plains support syndicate financed extraction plants processing up to 2000 cubic yards daily.

The Inverell-Glen Innes district, New South Wales, and the Anakie district, Queensland, are the only major commercial production centres for Australian sapphire and zircon gemstones. Australian blue sapphires dominate the world sapphire market, despite unfavourable dichroism and brilliance, because of the declining production from the classic southern and south-eastern Asian sources.

INTRODUCTION

Sapphires are associated with the Quaternary alluvial sediments of New South Wales, usually in stream drainage areas associated with Tertiary basalt cover. They have been recovered in the Oberon, Porters Retreat, Crookwell, Mittagong, Hill End, Wee Jasper and Mundle river alluviums. They are also associated with the buried Tertiary gravels at Mount Werong, Vegetable Creek, Airly Mountain and elsewhere. The Inverell and Glen Innes area of north-eastern New South Wales has sufficient concentration of quality stones to encourage commercial production for the international gem markets. The alluvium of the Fraser and Reddistone Creeks between Inverell and Glen Innes are commercially viable sources of sapphire and zircon gemstones. This mining district is the smaller of Australia's two major sapphire mining areas. The

economic geology of the rival Anakie sapphire mining district in east-central Queensland was discussed previously in this *Journal*.* The extent of the Inverell-Glen Innes sapphire deposits in the New England district of New South Wales has only been realized since the early 1960s. In the last decade commercial production has expanded to rival the Anakie district in Queensland. Most of the production, historically and at present, has been associated with Fraser's Creek, and its Horse Gully tributary near Inverell, and the Reddistone Creek north of Glen Innes in the vicinity of Bullock Mountain.

Sapphires have been recovered in the district and surrounding regions for more than a century. The placer tin and gold miners recovered the numerous crystals from their heavy concentrates. The first recorded observation of sapphires in New South Wales dates to 1851. A Mr Stutchburry observed their presence in a gold sluicing operation on the Cudgegong and Macquarie Rivers. A few years later, in 1854, a Rev. Mr W. B. Clark noted sapphires in the tin sluicing concentrates of the Inverell mining district (Curran, 1897). The recognition of these New South Wales sapphires predates the discovery of the famed Anakie fields of central Queensland by a couple of decades.

The initial identification of the sapphire crystals was considered valid, but they were dismissed as essentially worthless. Quantities of sapphires were recovered in 1869 and 1870 from the buried gold-bearing gravels (Tertiary) associated with the ancestral Cudgegong River in the vicinity of Gulgong. They were again discovered in the Oberon area on Native Dog Creek in 1878, also incidental to gold prospects and sluices.

The first commercial mining of sapphire deposits in New South Wales was attempted in 1919 on the Fraser Creek claim of C. L. Smith. It is now at the site of the small village of Sapphire, north-east of Inverell (Figure 1). The recorded production for Smith's first year of operation was an uneconomic return of eight ounces of corundum and sapphire. Nevertheless new deposits were delineated for future exploitation. Commercial sapphire mining developed on a larger scale during the 1920s between the towns of Inverell and Glen Innes in the gemmiferous alluvial gravels associated with Fraser's Creek, Horse Gully, Mary Anne Creek in

*J.Gemm., 1979, XVI (5), 318-37.

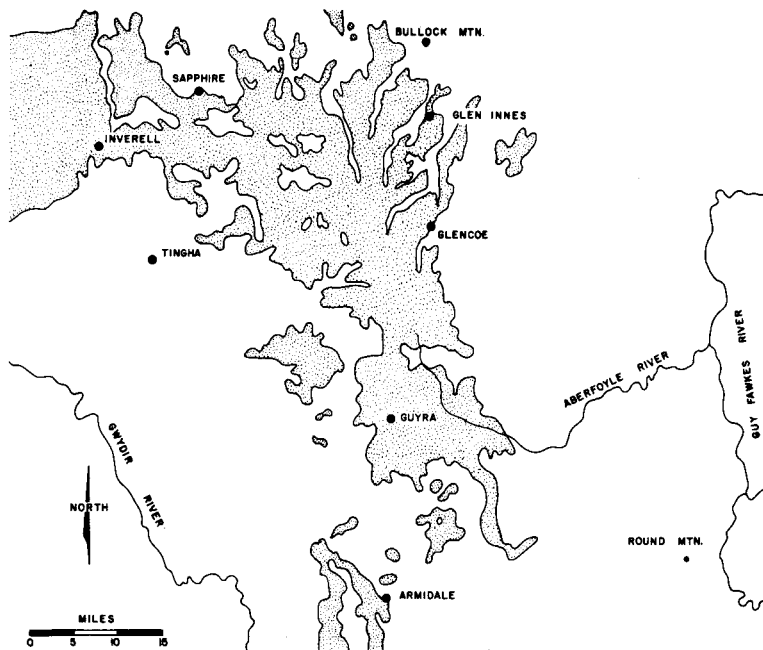

FIG. 1. Generalized distribution of Tertiary basalts and associated sapphire-zircon gemmiferous gravels (stippled) in north-eastern New South Wales. (Adapted from MacNevin, 1971)

the vicinity of Inverell and Sapphire townships, and Reddistone Creek near Bullock mountain, north of Glen Innes (see Figures 1 and 2). Minor interest was directed towards Copes Creek near Tingha township. The sapphire mining industry was relatively stable until the Great Depression after which production ceased until the early 1960s.

GEOLOGY OF THE GEMMIFEROUS GRAVELS

North-eastern New South Wales is a region of widespread Tertiary to Holocene sapphire bearing sands and gravels overlying a bedrock of Permian granites, prophyries, volcanics and Permo-Carboniferous metasediments and intercalated Tertiary flood basalts. Dissected Tertiary plateau basalts cap most of the topographic highs (Figure 1). The gemmiferous gravels are generally associated with the modern drainage system. Sapphires

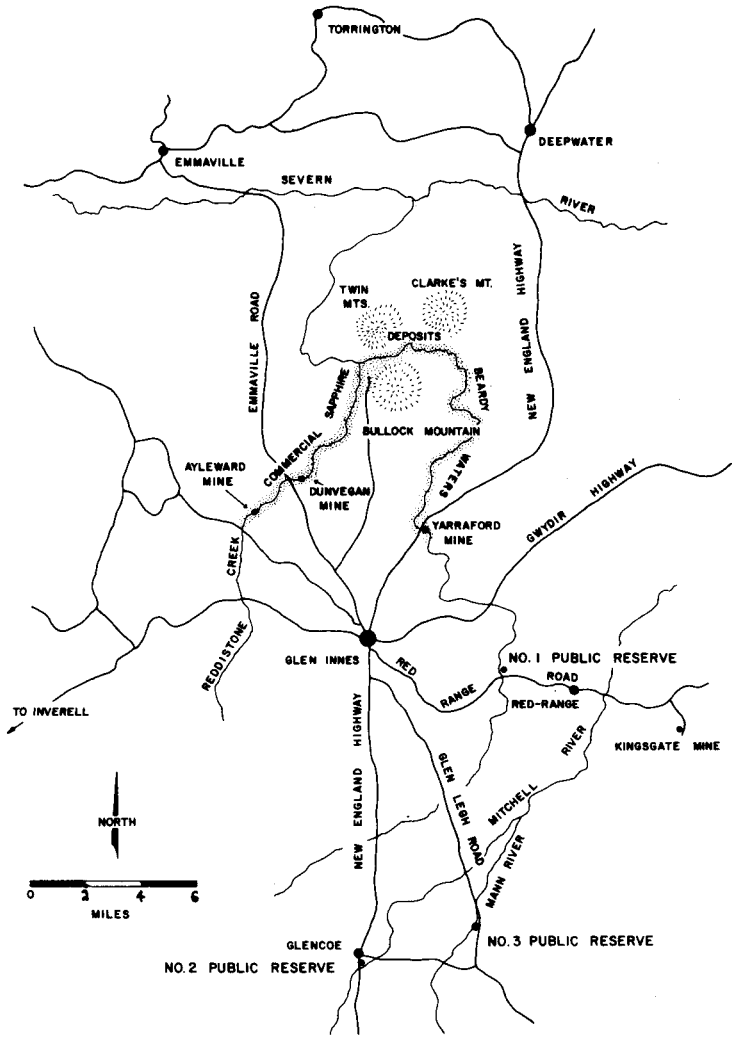

FIG. 2. The Glen Innes sapphiring district. The commercial sapphire bearing gravels (stippled) are associated with the Reddystone and Beardy Waters alluvium.

are also found in weathered basaltic soils in older sediments, preserved at higher elevations than the modern drainage systems. The streams have locally breached the Tertiary basalts and subsequently reworked the buried Tertiary gem gravels into Palaeozoic basement rocks, which characterizes commercial deposits of the district.

The sapphire deposits are concentrated in irregular zones and reflect the undulating basement subcrop surface. Concentration is favoured within the inside of meander bends of older phases of the drainage system and within trough and pothole traps of the river bottom. The lowermost zones of these sediment traps have the highest concentrations of gem sapphires, especially within 5 feet of the bedrock surface.

The drainage system and associated gem gravels display a regionally distinctive radial pattern about the flood basalt of the district (MacNevin, 1971). These volcanics are associated with two major periods of volcanism: the 'Older Series' of Oligocene to Miocene age and the 'Newer Series' of Pliocene age. They are separated by a widespread laterite-bauxite horizon of late Miocene age. Most of the regional gem gravel trends (termed 'leads') have been deposited in channels that have eroded through the basalt sequences. The aerial distribution of the gravels indicates the source of the sapphires to be these Tertiary basalts, but only as a secondary source. The actual *in situ* mother rock has never been discovered. Pleonaste, the opaque black spinel, is a prolific component of the corundum- and gem-sapphire-bearing gravels. Considering its similar chemistry to sapphire, it is likely that the two species have the same igneous source. However, megascopic sapphires have never been found *in situ*, and only the pleonaste crystals are abundant in the local olivine basalt outcrops. Some sapphire crystal fragments have been observed embedded in basalt erratics worked from the gem gravels. Both the sapphire and pleonaste grains found, independently, in the basalts have very thin chemical reaction rims within the adjacent fine-grained olivine. An alumina-rich reaction halo around these zencrysts is lacking. There is a total lack of fine-sized corundum grains in the basalt specimens. The size and perfection of the corundum crystals implies a prolonged degree of metamorphism not supported by field and petrological examinations of the basalts. MacNevin (1971) concluded that the basalts acted as an enveloping and trans-

porting mechanism for bringing corundum crystals, formed independently at depth, to the surface. This actual original source horizon has never been recognized in the subsurface nor is, so far as is known, exposed on the surface.

The gemmiferous gravels are composed of angular to well-rounded clasts of granite, porphyry, metasediments and basalt as well as the heavy mineral concentrates. The heavy mineral concentrate fraction includes sapphire, corundum, pleonaste, red and orange-brown to colourless zircon, ilmenite, black tourmaline, enstatite, quartz, garnet, bauxite, hematite and infrequently gold and diamond.

THE MAJOR GEMMIFEROUS GRAVEL TRENDS

The commercially exploited sapphire-zircon bearing gravels are distributed as two major trends, termed 'leads': Fraser's Creek and its tributary, Horse Gully, north-east and east of Inverell; Reddistone Creek and its marginal gravels on Bullock Mountain, north of Glen Innes.

Future commercial sapphire production in the district will likely include the at present marginally uneconomic sediments associated with the Mitchell River, Marowan Creek, Beardy Waters, Wellingrove Creek and Cameron's Creek in the Glen Innes area and the King's Plains, Bingara, and Tingha areas near Inverell. The main drainage courses from watersheds rising in the basaltic regions of the Great Dividing Range all carry sapphires. These rivers include the Severn, MacIntyre, Mitchell (Mann), Gara, and the Bundra (Gydir). Most of the gravels associated with these creeks and rivers have once had localized commercial production. The Mitchell River, Marowan Creek and the Beardy Waters near Glen Innes have exploitable deposits capable of substantial production under improved and stabilized market conditions.

The northern and eastern slopes of Bullock Mountain probably have the best reserves of gemmiferous gravels in the district. This area comprises the Reddistone Creek section downstream from the junction area of the Reddistone with the Beardy Waters on the north slope of Bullock Mountain, west of Twin Mountains, and the section of the Beardy Waters on the eastern slope of Bullock Mountain and south slope of Clarke's Mountain, north of Yarraford (see Figure 2). This is a largely inaccessible area with little or no roads in steep, mountainous terrain. Several small,

'two-man and backhoe operations' are presently engaged in this area. Their success is largely related to world market fluctuations and the localization of rich gravel concentrations.

The Fraser Creek and Horse Gully Deposits

The Fraser Creek and Horse Gully deposits are the main commercial sapphire production zones between Inverell and Glen Innes. Nearly two hundred mines have been operational in the past, about a hundred excavations each on the Fraser Creek and along the Horse Gully valley.

Sapphires are not deposited in the Fraser upstream from its junction with Horse Gully. Miners hypothesize the source of the sapphires to be from the vicinity of Swan Peak at the head of Horse Gully, 4 miles south-east of Sapphire. From this area they were transported into Horse Gully and thence into the Fraser at Sapphire and eventually worked down stream (north-west) in commercial concentrations as far as Nullamanna. Sapphire crystals have also been found in the Swan Creek south of Swan Peak. The Dominion Mining Corporation established one of its several plants on the river bed west of Swanvale, but temporarily suspended production because of economic recession (1975).

Commercial mining of the Horse Gully gravels is the most viable in the Inverell-Glen Innes district. Two mining syndicates essentially control this deposit: the Arrawatta and the Stellar Corporations. Their mines on the Horse Gully are 15 miles north-east from Inverell off the Swanbrook Road towards Wellingrove. A half mile beyond the Sapphire Post Office, the posted turn-off road north-east towards Swan Peak continues about a half mile to the access road into the Arrawatta property. Another two miles distant to the east is the Stellar's access road to their Horse Gully claims.

The mile-long access road into the Stellar claims crosses the largest and richest sapphire grounds of the entire district. The Horse Gully Mine is comprised of two open-cut pits on opposite sides of the mine office and wash plant. Stellar Mining, established in 1969, is one of the few commercial sapphire mines in the country that both mines and retails its own cut and polished gemstones. Most other mines sell directly to foreign buyers that regularly visit the producing fields. Stellar's sustained quantity and quality of production has helped to maintain marketing offices in London,

Amsterdam, Berlin, Florence, Madrid and New York. Most of the mine's commercial sapphire supply have the deep royal blue hues characteristic of the Horse Gully area; there is also a limited production of golden yellow stones. The Stellar operation has two trenches each approximately 300 feet long, 60 to 100 feet wide and averaging 10 to 15 feet deep. Two scrapers at each pit remove 6 to 10 feet of overburden above the white stained clay and gravel wash, and back-fill it into the adjacent, previously excavated trench (Figure 3). Four to seven feet of gemmiferous gravel are removed with backhoes onto trucks for the quarter mile haul to the washing plant. The sapphire-bearing gravel is unconformably deposited on a yellowish green bedrock, the uppermost foot of which is usually decomposed. This friable, weathered bedrock zone is also excavated and processed with the wash to ensure recovery of any sapphires trapped on the irregular bedrock surface. The two trenches are capable of producing between 500 and 600 cubic yards of wash a day for the processing plant.

Adjacent to the Stellar Mining properties are the extensive holdings of the Arrawatta Company. This company has intermittent and limited production depending upon favourable international marketing conditions. The managers utilize unfavourable periods, e.g. the mid-1970s, to intensify exploration for the more economic gravel concentrations that are salient from the Stellar property.

The largest commercial operation on the Fraser Creek is the Dominion Company's plant, 2.5 miles west of the Sapphire Post Office. Two washing plants are constructed on the extensive properties leased from the Norine Martin estate. The larger plant has a capacity to process a voluminous 2000 cubic yards daily while the second plant is very small with approximately 150 cubic yards per day. This is undoubtedly the highest capacity of any sapphire mine in Australia, if not the world. After the large plant was built in early 1974 its volume of production was instrumental in precipitating the collapse of the 1974-75 sapphire price structure on the world gem markets. The overproduction and falling prices forced the plant to be abandoned after only six months operation, and emphasis was shifted to the smaller 150 yard washing plant (Figure 4). The wash is between 5 and 10 feet thick and under but a couple of feet of topsoil. The open-cut mine is more than a thousand feet long and half as wide. These plants were situated at



FIG. 3. Excavation of the sapphire-bearing gravels at the Stellar mine on the Horse Gully.

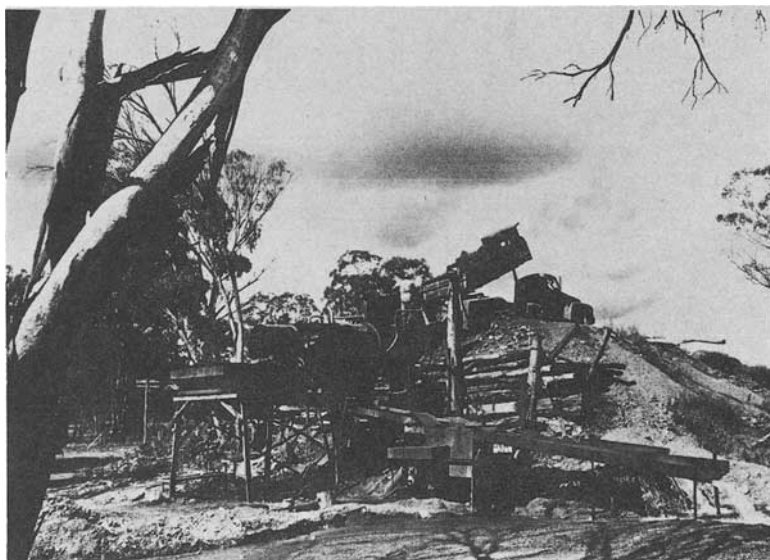

FIG. 4. A wash plant operated by the Dominion Company on Fraser Creek. The sapphire-bearing gravel is dumped into a flat, open-ended box and washed into a rotating sieve to remove the over-sized gravel and sand. The remaining slurry is sluiced to a pulsating jig where the sapphire-zircon concentrate is trapped behind a series of riffles.

the junction of the Horse Gully and Fraser where significant concentrations of sapphire have been discovered. The gem gravels infill a half mile wide flood plain at this junction which is one of the widest zones of sediment accumulation associated with the Fraser.

The company operates the small plant with but two men, one of whom loads a truck with backhoed gravel and delivers it to the washing plant. The other employee washes the gravel with a hydraulic hose from the dump box and into the plant's trommel and pulsating jig.

The mining leases of the Saunders family and the adjacent leases of Allen Scheb are downstream from the Dominion Company plants, midway on the Fraser between Nullamanna and Sapphire. These claims cover a mile long section of the Fraser, 5 miles upstream from Nullamanna and 6 miles downstream from Stellar mine on Horse Gully. The half mile wide flood plain of the Fraser, characteristic of the Horse Gully junction area, quickly narrows and becomes entrenched within a narrow gorge between Nullamanna and Sapphire. Granite outcrops bank and protrude from the creek bed. The gravel deposits are seldom more than a hundred yards wide on the Fraser from the Scheb mine downstream to Nullamanna and beyond (Figure 5). While the sapphire-bearing wash may be very thick, the narrowness of the deposits and the rugged topography inhibit large-scale open-cut mining by well financed corporations similar to the Dominion or Stellar operations. Consequently this section of the Fraser has been traditionally exploited by two man mining partnerships. Regardless, they are the most sensitive to fluctuations characteristic of the international sapphire market.

The availability of very thick wash in the gorges is a dominating criterion of success or failure for these small independent mines. The number of small mines fluctuates rapidly between one or two dozen and a couple of hundred. The introduction into the district of the mechanical backhoe during the early 1960s provided for efficient and economical excavation of the wash from between the trees and outcrops within a narrow gorge. The backhoe can effectively extract the gravels between outcrops down to bed-rock surface, as well as gravel-filled potholes in the river bed. One particular excavation on the Saunders claim was a deep trench between two granite knobs but ten feet apart. The excavation at the time of observation was only 6 feet into a pothole that was proving

to be a rich sapphire concentration. A similar excavation on the claim was a 20 foot wide patch of gravel between two flat outcrops that was but the narrow surface expression of a 30 foot deep pit into the bedrock. Several pounds of fine gem sapphires were eventually recovered.



FIG. 5. Gemmiferous alluvium partially excavated along the Fraser Creek. Note the narrow valley fill suitable only for small scale mining operations.

The Saunders operate two washing plants along the Fraser, and the adjacent Schebs claim only one. The Saunders are sheep and grain ranchers but intermittently utilize the sapphire mines to help themselves through unstable agricultural market conditions. This is a typical approach by local small landholders. Since they do not have sufficient manpower to work both businesses effectively, the mine is operated on the tribute system. The Saunders provide access to the land to a pair of miners who put up the machinery and necessary labour for an equal split of the recovered gemstones.

The Fraser river bed at Nullamanna is worked by the Brown

claim. This is upstream and adjacent to the public sapphire digging area of MacIntyre Shire. The area is north from Inverell towards Ashford, and after 4 miles, the north-east turn-off for Emmaville and Nullamanna is reached. The turn-off is approximately a hundred yards after crossing the Swanbrook Creek bridge. The bridge over the Fraser is reached after 1.6 miles on this turn-off road, past the Nullamanna Post Office. The turn-off into the public digging area is indicated just south-east of the bridge. The area is designated the MacIntyre Shire Sapphire Fossicking Area, but is more commonly known as the Nullamanna public digging area. It was set aside for public recreation in early 1974. Approximately a quarter mile of river section upstream from the bridge is permitted for public digging (Figure 5). The Brown commercial operation is upstream with control over the next mile of creek bed.

The public digging area is overseen by a caretaker during the digging hours of 9.00 a.m. to 5.30 p.m. on Tuesday, Thursday, Saturday and Sunday. A daily collecting fee (1975) of two dollars is charged. There are several other public collecting reserves that have been set aside in the district, and all except this one at Nullamanna require the possession of a prospecting licence. The collecting fee essentially covers the cost of backhoeing a trench in the creek bed and stockpiling the gem-bearing gravel. The casual prospector can either fill a bucket from the stockpile, continue the excavation, or, if desired, start his own trench.

The grey-white to sandy yellow gem gravel is very coarse. Half the volume is boulders upwards of a foot in diameter. The wash lies on a granite bedrock that outcrops along the narrow valley walls throughout the area. The gravel deposits are generally 10 to 20 feet thick and unevenly distributed within the narrow flood plain. The gorge's bottom sediments form a plain generally less than a hundred yards wide. Portions of the public digging area were once commercially worked in the early 1960s, but with inefficient equipment. Sizable patches of unworked ground remain for public access.

The public reserve has three 10 foot diameter water troughs to facilitate screening the gem gravel. Popular screens utilized are the half-inch and sixteenth-inch mesh sizes to eliminate the coarse gravel, fine sand and clay. Sorting is generally done on a burlap cloth. The recovered sapphires tend to be small, generally under a carat, but of a fine blue colour.

The Reddistone Creek Deposits

The gemmiferous gravels of the Reddistone Creek and those on the lower reaches of adjacent Bullock Mountain are second in importance to the Fraser Creek gravels (see Figure 2). The main production area is the section of the creek bed and associated alluvium eight miles north-west of Glen Innes, midway towards Wellingrove.

The Reddistone Creek deposits are similar to the Fraser. The upstream portion of the commercial sapphire mining district is a half-mile wide alluvial flood plain that tends to support large, syndicate financed, mining operations. Downstream, north-eastward, the Reddistone winds between Bullock Mountain and surrounding peaks. And similar to the Fraser, it becomes entrenched eastward into a narrow gorge capable of supporting only limited partnerships.

There are only two major and several small commercial mines excavating the Reddistone Creek gravels. The Graham and Ayleward operations are the largest mining operations on the Reddistone Creek. Most of the creek will be worked out by 1980.

The largest mine is the Ayleward mine on the Reddistone, north of the Glen Innes airport. It is off the road to Emmaville north from Glen Innes, past the bridge over the Reddistone Creek about 2.6 miles north of the airport. The Wellingrove Road turn-off to the west is another 1.6 miles further. One mile west on the Wellingrove road is an unmarked fence gate, which gives access to a two mile long private road southward to the processing plant on the creek. The Ayleward claim controls the three mile valley between the bridge on the Emmaville Road and the Wellingrove Road. The flood plain averages a half mile wide along most of this section.

The processing plant has been operational at this site since 1974 when the company moved the machinery from worked out claims on Bullock Mountain. The new location has relatively rich, although thin, wash deposits. The brown-coloured gemmiferous gravel is but 9 to 12 inches thick and under 4 to 6 feet of topsoil. Effective utilization of mechanized earth moving equipment and reasonably significant concentration of sapphires favours the economic viability of the operation. Six to eight men operate the 200 yard a day mine and wash plant.

The Dunvegan mine (Figure 6) is a small two man partnership

of the Davidson family and is adjacent to the down stream extent of the Ayleward leases on the Reddistone. The two mile long access road to the property is about a quarter mile north of the bridge on the creek, 2.7 miles north of the Glen Innes Airport on the road to

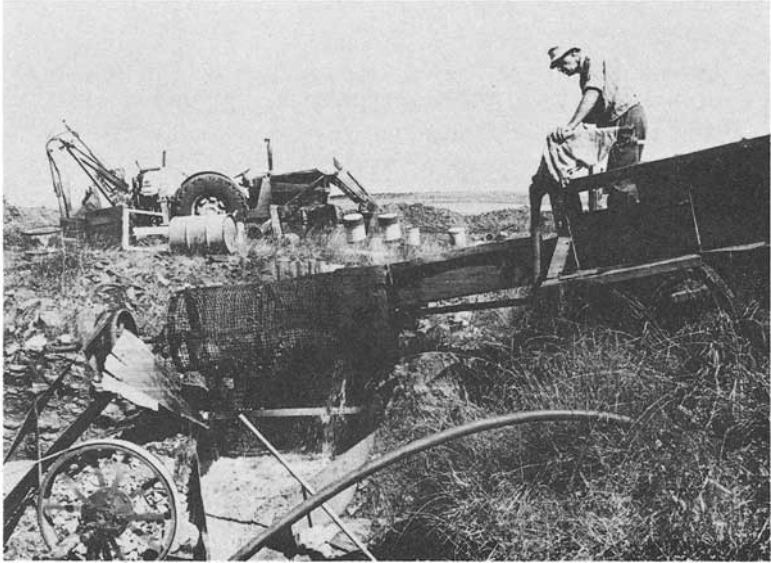

FIG. 6. A typical small wash-plant operated by a single miner. This plant at the Dunvegan Mine on the Reddistone Creek is capable of a daily processing of approximately 40 cubic yards of gemmiferous gravel. It relies on a tractor to power the trommel and pulsating jig.

Emmaville. The Dunvegan Sapphire Company claim is important as a portion of the property reserved for public digging upon payment of a daily fee of three dollars. The public access area is about a thousand feet upstream from the processing plant. Most of the digging area set aside for public use is very marshy and filled with backhoe excavation trenches. How successful individual diggers are on this property is unknown to this writer.

Down stream from the Dunvegan property, the Reddistone Creek has mixed topographic characteristics: steep valley walls with narrow ribbons of gravel as well as wide flood plains capable of supporting larger commercial enterprises. The north-eastern (down stream) limit of major commercial sapphire mining is the Bullock Mountain area, nine miles north of Glen Innes

(Figure 2). Bullock Mountain has the Reddistone Creek gravels on its western slopes and the Beardy Water gravels on the eastern slopes. Both of these areas have been extensively mined in the past. Production of fine quality, sizable, royal blue sapphires is characteristic of this section of the creek alluvium.

The most important of the Bullock Mountain mines is the Graham mining claim on the western slopes. It is reached by the road to Emmaville north from Glen Innes towards the airport. The first gravel road turn-off to the north-east gives access to Bullock Mountain. This turn-off is 2.3 miles south of the airport and 1.1 miles north of a wooden bridge over the Beardy Waters at northern city limits of Glen Innes. The gravel road continues north-eastward for approximately three miles to terminate on the 14 acre leases within the rugged Bullock Mountain slopes.

The alluvial fill on the claims meanders parallel with the course of the entrenched creek—only tens of feet wide in places but often several hundred yards. The property includes a half mile wide section of flood plain at its upstream limits. Most of the mining claim area has three or four feet of gem gravel under only inches of topsoil.

The Graham property was formerly owned and operated by the Stellar Mining Corporation, whose main plant is on Horse Gully near Sapphire. Stellar constructed a poorly designed plant that after six months of operation yielded only meagre returns. Attributing this to low concentration of sapphires in the gravel, Stellar sold the 'barren' ground to Graham in 1970. The new owners redesigned the recovery methods and proceeded to mine the rich sapphire concentrations. The Graham mining methodology is almost unique. It utilizes a power-shovel to excavate, while most other companies have backhoes and/or scrapers. Two men only are required to operate this high volume mine because of the excavation capacity of the power-shovel.

Casual Prospecting Deposits

Most commercial sapphire mines will tolerate private individuals to collect on their property *only* if politely approached well in advance, and then, again, only if no large groups are involved. In addition, the New South Wales Department of Mines

has designated several areas for public prospecting groups. There are four designated ones in the Inverell-Glen Innes district. The MacIntire Shire reserve on the Fraser Creek at Nullamanna in the Inverell area has been discussed previously. The Glen Innes area has three Department of Mines designated public reserves (Figure 2), as well as a privately controlled property available for public use. Public Fossicking Area No. 1 is reached by taking the Red Range Road east from Glen Innes for 8.5 miles to an old wooden bridge. The digging area is a 1000 foot long and 100 foot wide section of flood plain on the east bank. Dozens of two or three foot diameter pits excavated by sapphire prospectors delineate this area.

Public Fossicking Area No. 2 is reached by taking the New England Highway south from Glen Innes for 14 miles to the small town of Glencoe. A bridge over the Marowan River at the south end of town is adjacent to an extensive mile wide flood plain. The designated digging area is north-east of the highway bridge amid a meander bend of the river. The area is about 200 feet long and 100 feet wide. This area has a favourable reputation for availability of sapphires. Dozens of 3 to 5 foot diameter pits scar the area. The alluvial sediment is characterized by a proliferation of 6 to 8 inch boulders, and unfortunately, water seepage.

Public Fossicking Area No. 3 is reached by taking the New England Highway (Highway 15) south from Glen Innes for 1.5 miles and turning east onto the Glen Legh Road towards Blair Hill. The digging area is adjacent to the bridge over the Mann River, 13 miles south of Glen Innes and 2.3 miles past an abandoned commercial sapphire mining property on Blair Hill. The public digging area is the south-east bank of the Mann River. An area of about 500 feet square has been fenced off for this purpose. The area, however, is very overgrown and mostly topsoil and/or very fine gravel. There are very few trenches dug by sapphire prospectors.

These three public digging areas require the possession of a prospecting licence, obtainable for two dollars a year at any court house in the vicinity.

A private claim available for public prospecting upon payment of a daily fee is the Yarraford property (Figure 2). It is adjacent to the New England Highway, 6 miles north of Glen Innes and on the banks of the Beardy Waters.

Extractive Methodology

All producing claims for commercially exploiting the gem gravels in the Inverell-Glen Innes mining district utilize a wash plant to sieve and gravity separate the gemstones from the waste gravel (Figures 4, 6 and 7). The smaller wash-plants process between 40 and 60 cubic yards a day with a labour force of two or three men, whereas the largest syndicate operated plants have daily capacity of 2000 cubic yards and employ as many as 10 to 15 men.

The wash plant of the Stellar Corporation on Horse Gully is typical of the medium-sized plants. The wash is unloaded into one of the pair of 'dump boxes' at the plant: wide, shallow-angled chutes about 20 feet in dimension. Along the side of each chute is a hydraulic hose with 40 lb/inch² pressure to sluice the gravel into a series of troughs (Figure 7). The slurry is directed into dual rotating trommels with fine and coarse screens to separate the waste. The trommel's fine size retention mesh is a sixteenth of an inch. The slurry is directed from the trommel's conveyor belts into a jig pulsator, which is a gravity separator. The Stellar plant utilizes a three cell device, each cell about 4 feet deep and 3 feet square. Each

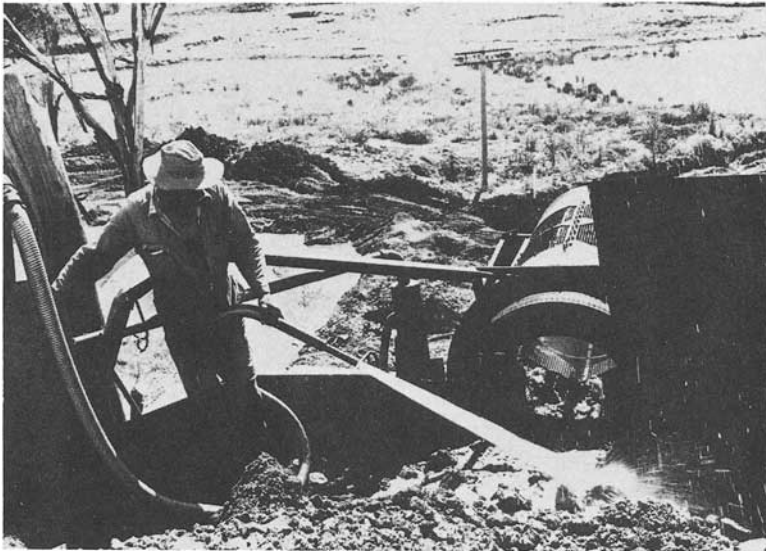

FIG. 7. Washing gemmiferous gravel from the dump box into a rotating trommel, where the fine gravel fraction is separated out for additional processing.



FIG. 8. Cleaning the pulsating jig traps of sapphire-corundum-zircon concentrate on the Reddistone Creek.

water-filled cell has a screen through which water is circulated up and down by an undulating piston. This pulsating water forces the heavier gemstones in the gravel to settle on the screen and be subsequently trapped behind a series of riffles (Figure 8). The lighter, barren waste material continues unobstructed over these and is directed towards a settling pond and waste dump.

The operation at the Graham plant on Bullock Mountain is similar and with only minor variation. The gravel is dumped and washed into a 30 foot long, 8 foot diameter, trommel. The sized gravel, free of sand and boulders, is then split into two pulsating jigs on either side of the trommel. Each jig has three pulsating cells. The plant has a daily capacity of 500 cubic yards. The processing

plant of the Ayleward mine on the Reddistone Creek, on the other hand, uses a pulsating jig with 12 traps built into the bottom of a 12 foot long, 5 foot wide trough. Each trap is 2 feet long and 6 inches wide and deep. The traps are cleaned twice daily and the concentrate is shovelled into five gallon pails.

The smaller claims operated by two or three men normally have a wash plant capable of processing approximately 40 cubic yards a day. Many on these Fraser Creek claims use a tractor as the power source for the trommel, pulsating jig and related machinery (Figure 6). The Brown plant utilizes an 8 foot long, 2.5 foot diameter, trommel with a 0.75 inch boulder reject mesh. A flume feeds the gravel from the trommel into a two cell pulsator.

The processing plant of the Davidson family-operated Dunvegan Mine has a daily capacity of 50 to 60 cubic yards. A tractor is geared to drive the single cell pulsating jig and 8 foot trommel.

PRODUCTION, SORTING AND MARKETING OF THE SAPPHIRE-ZIRCON CONCENTRATE

The gemmiferous gravels of both the Inverell-Glen Innes district, New South Wales, and the Anakie District, Queensland, are processed for marketable sapphires, corundums, diamonds and zircons. Only the gem quality sapphires, however, have appreciable market value, and the other gemstones are considered by-products that may be stockpiled to await sufficient demand. The diamonds are industrial grade only and relatively rare.

Production of Concentrate

Production of the heavy mineral concentrate (unsorted mine-run gemstones) varies widely throughout the Inverell-Glen Innes district.

At the Stellar Corporation mine on Horse Gully, the gemstone proportion is usually 20 per cent of the jig concentrate. Between 15 and 20 per cent of this, and sometimes as much as 50 per cent, is zircon. The finer quality blue-hued sapphires are associated with the higher percentages of component zircon at the Stellar plant. Some garnet and an occasional industrial diamond are also recovered, as well as the ubiquitous opaque corundum and spinel. The Stellar wash plant utilizes a heavy liquid separation tank for a

finer density separation of the concentrate after removal from the pulsator jig traps. Most other commercial plants bypass this step in favour of direct hand-sorting. The 'Cyclone 60' media separate the hematite and basalt fragments from the gem material in the heavy mineral assemblage. Daily production varies widely, but the Stellar plant averages 250 pounds of mixed gemstone concentrate for direct shipping to the company offices. In Sydney the concentrate is sorted, graded and accordingly finished into marketable faceted gemstones.

Most of the Graham mine concentrate yields an ounce of sapphire to 10 cubic yards. Sometimes, very rich concentrates with as much as an ounce per cubic yard are encountered in depressions of the bedrock surface. The plant produces 20 to 30 gallons of jig concentrate a day. This is shipped to Glen Innes for sorting and grading. The concentrate is fed into a smaller, table-sized version of the pulsating jig for a finer separation, then to a magnetic separator to remove most of the black spinel and finally onto a light table to hand-pick the gem sapphire from the corundum. About 20 per cent of the concentrate is marketable sapphire, mostly deep blue and unusually free from silk. The concentrate fines, less than an eighth inch, are saved and sold for industrial corundum abrasive. Almost no garnets are recovered from the Graham concentrates, but there are sizable quantities of clear to reddish brown zircon. It is common to recover sizable, flawless, zircon crystals upwards of a hundred carats.

Half of the concentrate from the pulsating jig is a non-gem corundum and spinel, and half varying proportions of gem sapphire and zircon. At least half of the gem sapphires from the Saunders and Scheb section of the Fraser is a deep royal blue, about a third green or mixed blue and green, and the remainder mostly light yellow.

The Brown plant recovers an average of three ounces of commercial grade sapphires daily. They have recovered less than an ounce on poor days, but sometimes as much as eight ounces. Half to three-quarters of these stones are blue and the remainder mostly yellow-green. There is considerable zircon. The sapphires produced from these mines are rough fragments of irregular shapes, but infrequently crystal sections with recognizable faces are recovered. Infrequently recovered are elongated, inch-long prisms, pointed to resemble fangs: hence, the local term 'dog's teeth'.

Sorting and Grading

The smaller mines with two or three men in partnership generally sort and grade at the mine site. The larger volume mines, financially backed by major syndicates, ship their concentrate to a central office for sorting and grading.

Procedures of sorting the concentrate vary considerably. The first step is to separate fractions of the concentrate: the ironstone, rock fragments, quartz pebbles, ilmenite and black spinel from the corundum, sapphire, zircon, topaz, garnet and an occasional industrial diamond. This separation involves hand-picking on a light and/or mirror table, although larger volume processes utilize heavy-liquid media and magnetic separators. The gem fraction of the concentrate remaining is then sorted, usually but not always into various size fractions, and then graded. The commercial quality sapphires are separated from the corundum and other associated gemstones. At this point, the entire quality range of sapphires are separated: any corundum crystal reasonably semi-transparent or better. The remaining opaque corundum and zircon may be sorted and graded depending upon existing market conditions.

All sapphires separated out constitute a 'mine run' and sometimes are sold by the ounce by small mine operators to the foreign buyers visiting the fields. The mine run is often graded into 'firsts', 'seconds', and 'thirds' to bring a higher price. These grades refer to quality and may be further subdivided into as many as six or eight size categories by the large mines or two or three by the independent operators.

Size categories for sapphires are designated by number of pieces per ounce, e.g. 100, 50 and 25 pieces per ounce. An individual crystal is rarely sold and must be a particularly valuable stone.

The 'firsts' are those stones with a good, strong light to medium-blue colour and with only minor light coloured silk, if any, present. They are essentially with no visible flaws. The larger size categories, those comprising a parcel of less than 50 pieces per ounce are often termed 'specials'. 'Seconds' have only a fair blue colour without serious flaws or cracks and perhaps minor detrimental silk, or are poorly shaped and required difficult cutting procedures. Some dark blue-black stones may be considered in this category. 'Thirds' are those stones having bad cracks and flaws,

heavy silk concentrations or are off-coloured. A stone in this category can usually be cut but is of poor quality and value. Stones that are a combination of blue and green, or blue and clear are termed the 'parti-colours'. They are usually classified with the 'thirds'. The combination of 'firsts' and 'seconds' constitutes usually around 60 per cent of the mine run.

Comments on the Australian Sapphire Market

Australia supplies approximately eighty per cent of the world market for commercial blue sapphires. Foreign buyers on the Australian fields are generally interested only in the blue hues. Sapphires of yellow and green colours, less so for the parti-coloured, are sold on the local Australian market. There is a substantial international demand, however, for the relatively rare golden yellow sapphires, the values of which may approach the sapphires of 'royal' blue hues.

Australian blue sapphires currently dominate the world sapphire market, but largely because of the rapidly declining production in south-east Asia. Certain optical qualities that characterize Australian stones are considered detrimental: the significant degree of dichroism, and the overall dark blue to blue-black hue that lacks brilliance and in fact is often dubbed as 'dead looking' in artificial light. Most stones display a strong, deep-hued royal blue colour in the direction of the *c*-crystallographic axis and have a blue-green hue on the *a*-axis. This green tint darkens the overall appearance and must be compensated in the cutting by shallower angles yielding a thinner stone. The Anakie (Queensland) district stones are particularly noted for their dichroism, though the 'Scrub blues' from the Scrub Lead of this district tend to be a lighter hue than average and thereby are favoured in commercial markets. The most brilliant Australian sapphires, free from silk and with minimal influence of the green dichroism, are the Reddistone Creek royal blues. However, these crystals are hampered by smaller than average sizes.

Perfection among Australian sapphires is the royal blue hue. It is considered by many to be inferior to the more brilliant, lighter 'cornflower' hues of Kashmir and Cambodia. Recent heat-treating experiments have been very successful in artificially lightening the deep blue-black hues of Australian stones as well as removing some

of the silk. These treated stones are difficult to distinguish from natural shades in a faceted gemstone. The risk is serious that such treatments will partially undermine this sensitive market. Heat treatment of inferior grades of sapphires is widely practised and the process is being introduced as well into the small Australian commercial lapidary industry.

Gem dealers from Thailand dominate the commercial trade in Australian sapphires. Virtually all foreign buyers of the sapphires are Thais, although there are a few infrequent buyers from Hong Kong, Japan and Western Europe. Some of the very largest mines, however, e.g. Stellar mine on Horse Gully, do have their own cutting facilities and marketing outlets throughout Western Europe and North America. It has only been since the early 1960s that the buyers from Bangkok have established a sufficient world marketing system to encourage reasonably continuous production on the fields. Since the onset of the Great Depression in 1929 and up until 1959, there had been only relatively insignificant commercial interest. Australian sapphires were considered too dark and lacking in brilliance to be much favoured on the major European and North American markets. This revitalized market, however, has been the virtual monopoly of the Bangkok gem dealers. This has continued because the Australian rough can be faceted in Asia for only a few cents per carat, compared with 8 to 10 dollars a carat if faceted by commercial cutters in Australia.

The sapphire market conditions are generally unsatisfactory because of the rapid and extreme fluctuations in what the buyers on the fields are willing to pay for rough sapphires. Wholesale prices may decline on the fields as much as 50 per cent over a couple of months, and some of the price depressions may continue for a year or more.

A particularly bad recession in sapphire prices occurred during the 1974-1975 world wide industrial recession. The price for a mine-run ounce of sapphire fell from about 150 dollars (Australian) to less than 80. This decline may have been triggered by voluminous overproduction of some of the giant corporations like Dominions' 2000 yard daily capacity wash plant on the Fraser. Prices in a buoyant market for the finest quality rough have been as high as 4000 dollars an ounce for 'special' grades of 'firsts'. Finished faceted stones of the rich royal-blue will wholesale at 60 to 80 dollars a carat.

Attempts have been made in recent years to stabilize the sapphire market from fluctuation, as well as to assert more control on the world market by the producers. Some miners have tried to form a co-operative marketing system, but such attempts have failed or been only short-lived.

During the early 1970s there was an increased interest in, and value attached to, the fancy coloured sapphires. Nevertheless, it was not sufficient to encourage establishment of systematic markets overseas. Markets for the finer specimens of yellow, green and parti-coloured sapphires are lucrative in Australia, but only to a lesser extent in the United States. The Australian blue may not be perfection to the discriminating gemmologist familiar with the classic Asian sources, but the golden yellow from the Willows field and the green from the Tomahawk Creek areas of Queensland are without equal. The Ceylon yellow is too light and the Thailand yellow is more of an amber shade; Anakie yellow and green sapphires are readily becoming collectors' specials. White sapphires have been found but are extremely rare.

A particularly Australian sapphire is the black star, a dark stone with a copper-coloured asteriated sheen. Star sapphires are generally not widely recognized by the miners during field sorting and hence are not distinguished from the junk corundum. Australian black star sapphires achieved a small degree of desirability on the North American market in the 1960s but have since lost their appeal. They are difficult to sell at present, Opaque corundum will generally sell for 10 to 20 dollars a pound for use in precision instruments and gramophone needles.

REFERENCES

- Curran, J. M., 1897, On the occurrence of precious stones in New South Wales and the deposits in which they occur. *Jour. Proc. Roy. Soc. N.S.W.*, 30, 214-17.
MacNevin, A., 1971, Source of sapphires in the New England District, New South Wales. *Geol. Surv. N.S.W., Quart. Geol. Notes*, 3, 1-5.

[*Manuscript received 19th November, 1977.*]

GEMMOLOGICAL ABSTRACTS

BALL (R. A.), CLAYTON (N.). *Opal references and abstracts Part II*. Australian Gemmologist, **13**, 9, 307-10; **13**, 10, 334-6; **13**, 10, 363-6, 1979.

An extended bibliography of opal literature, the first part of which was published three years ago. R.K.M.

BANK (H.). *Changierender Granat (Mit Farbwechsel) für Alexandrit ausgegeben*. (Garnet with colour change sold for alexandrite.) Z.Dt.Gemmol.Ges., **28**, 1, 41-2, 1979.

The stone being discussed is blue-green-brown to pink violet. It was easily identified as garnet by its refractive index. E.S.

BANK (H.). *Edelsteine aus Brasilien*. (Gemstones from Brazil.) Z.Dt.Gemmol. Ges., **28**, 1, 21-34, 1979.

Extensive bibliography and map of Brazil showing deposits. Short historical summary; also short geological survey. The gems are listed according to their chemical compositions. E.S.

BANK (H.), LEDIG (R.). *'Honig gelbe' Topaz-Ulexite Dublette als Chrysoberyll Katzenauge ausgegeben*. (Honey-yellow topaz-ulexite doublet sold as chrysoberyll cat's-eye.) Z.Dt.Gemmol.Ges., **28**, 1, 43, 1979.

A cabochon honey-yellow stone showing chatoyancy sold as a chrysoberyll cat's-eye was seen to be topaz-ulexite under the microscope. E.S.

BANK (H.), RODEWALD (H.). *Schleifwürdiger roter durchsichtiger Chlorit: Kämmererit*. (Cuttable red transparent chlorite: kammererite.) Z.Dt. Gemmol.Ges., **28**, 1, 9-40, 1979.

Originally named after a mine director in St Petersburg in 1841—the original crystal came from Bisersk, was red-violet and had a mica-type shimmer. Hardness 2-2½. Very strong cleavage, and is therefore difficult to cut. E.S.

BANK (H.), SCHMETZER (K.), PROBST (S.). *Vanadiumgrossulare mit hoher Lichtbrechung (über 1.75)*. (Vanadium grossularites with high R.I. over 1.75.) Z.Dt.Gemmol.Ges., **28**, 2, 70-2, bibl. 1979.

The very intensive dark green crystal from East Africa shows an RI of 1.758 which is tabulated and compared to other vanadium grossularites, synthetic grossularite and goldmanite. E.S.

BLAK (A. R.), ISOTANI (S.), WATANABE (S.), MORATO (S. P.). *Espectros infravermelho da água e dióxido de carbono em águas marinhas e halbanitas brasileiras*. (The infrared spectrum of water and carbon dioxide in Brazilian aquamarines and halbanites.) Gemologia, **23/24**, 45/46, 61-6, 3 figs, 1978.

Infrared spectra of aquamarines and dark blue irradiated beryl ('halbanite') are discussed and illustrated. M.O'D.

BORELLI (A.). *Diamanti di colore fantasia: tecniche per rivelare se la colorazione sia naturale o ottenuta per trattamento con radiazioni*. (Fancy-coloured

diamonds: a technique for testing whether the colour is natural or results from irradiation.) *La Gemmologia*, **5**, 1/2, 26-35, 12 figs, 1979.

Spectra of diamonds both natural and treated are shown in this study of the effects of irradiation upon colour and testing. M.O'D.

BOSCARDIN (M.), CECUZZI (B.), DE MICHELE (V.). *Osservazioni sui vetri naturali italiani*. (Observations on Italian natural glasses.) *La Gemmologia*, **4**, 3/4, 13-29, 15 figs, 1978.

Locations of obsidian in Italy are given and tables of constants provided. Specimens in thin section are illustrated. M.O'D.

BROUGHTON (P. L.). *Economic geology of Australian gemstone deposits*. *Min. Sci. Eng.*, **11**, 3-21, 14 figs (7 in colour), 1979.

The diamondiferous and the sapphire-zircon gem gravels of eastern Queensland and New South Wales are buried Tertiary fluvial deposits preserved from erosion by overlying basal flows; the igneous sources of the gem fraction are unknown. The Cretaceous Great Artesian basin across western New South Wales, Queensland, and northern South Australia is host for the precious opal deposits. In eastern Queensland chrysoprase veins are associated with serpentine; emerald deposits are known in the Precambrian Shield of Western Australia. R.A.H.

BROWN (G.). *The hazards of gemmology*. *Australian Gemmologist*, **13**, 10, 325-9, 1979.

An unusual paper, but in abstracter's opinion, a necessary one, drawing attention to the dangers of electrical installations, flammable liquids, poisonous nature of most gemmological liquids and radiation hazards from UV and x-rays. Excellent suggestions are made to minimize the risks to health involved, and advice on first aid, including resuscitation procedures for those whose breathing may have stopped following electric shock or other injury, is given. R.K.M.

BROWN (G.). *Turquoise—natural, treated, imitation or synthetic*. *Wahroongai News*, 21-34, April 1979.

Deals systematically with most aspects of this difficult gem material and gives some account of the formation of the natural material. A useful bringing together of information so far known on the subject. (The journal itself suffers from the same misprint problem as the *Australian Gemmologist*. Apparently produced by stencil cutting, this could be very easily corrected.) R.K.M.

CASSEDANNE (J.-P.), CASSEDANNE (J.-O.). *La mine d'améthyste de la Grotta do Coxó; une merveille inconnue*. (The amethyst mine of La Grotta do Coxó; an unknown marvel.) *Revue de Gemmologie*, **59**, 2-5, 7 figs, 1979.

The location is near Jacobina in the state of Bahia, Brazil. Amethyst is found in geodes with the tips of the crystals providing gem-quality material. M.O'D.

CROWNINGSHIELD (R.). *Developments and highlights at GIA's Lab in New York*. *Gems & Gemology*, **XVI**, 5, 147-54, 19 figs (some in colour), 1979.

Welcome return of this feature, although illustrations are no longer scattered at relevant points in the text. Deals cautiously with 'heat-treated' blue sapphires.

(Reports of this process have been around for a number of years but always at third hand. Doubt must exist whether there is a successful process even now.) Some stones showed signs of cracking due possibly to heat; greenish fluorescence, no iron absorption band (one stone showed a weak absorption similar to that seen very occasionally in deep-coloured synthetics).

Near-round Biwa-ko tissue cultured pearls, a flawless alexandrite of over 4 carats, red chrysoberyl which had no green daylight colour, also described. A 37 carat cubic zirconia seen. Parcels of this gem received for grading as diamonds, proved by size/weight ratio. Green fluorescence under long UV for pink spinel, and blue fluorescence of fancy brown old-mine cut diamond with 5040Å absorption are described. A blue treated diamond showed bright transmission in place of 5040Å absorption. Orange fluorescing pale pink diamonds have a transmission line at 5750Å, same as in treated pinks. Suggested that all treated pinks start as faint pink with orange fluorescence. Zirconium oxide submitted as diamond for grading responded to ink test as diamond. An obvious diamond responded to the same test as a synthetic imitation. Both stones had been coated; the diamond needed acid to remove coating. Good results reported from freezing techniques to improve absorption spectra (cf. London Laboratory, which has been using this for some time).*

Synthetic amethysts purchased for class use contained about 20% of natural stones. Since prices are similar such mixtures can be expected (did they take opportunity to do an UV transparency test?). A 2.71 taaffeite examined, pinkish grey-purple in colour. Needle-like inclusions seen in Verneuil synthetic ruby. Beryl beads with green plastic coating turned red under emerald filter; while a large 'emerald' crystal from Bogota proved to be a quartz crystal cracked apart and hollowed to take a smaller quartz, the interstices being filled with similar green cement. Large air bubbles included, and epoxy resin revealed by UV test. Green graining seen in natural diamond.

R.K.M.

DANIEL (P.). *Gem engraving—a dying art*. Industrial Diamond Review, 400-1, 4 figs, Nov. 1979.

A report on the work of Nicholas Lambrinidis, who is probably now the only living European exponent of Glyptography, the art and science of gem engraving. The engravings are made using diamond electroplated burrs of various sizes and shapes in a modern high-speed dental handpiece. Burr life is typically one week on a sapphire and two weeks on a topaz. The design is either incised as an intaglio, or engraved in relief to form a cameo. Mr Lambrinidis, who was a pupil of the British artist and gem engraving specialist Cecil Thomas, is currently setting up a Glyptic Section in the Goulandris Natural History Museum, Athens.

P.G.R.

DIEHL (R.). *Djevalith, Fianit, Zirkonia—Was ist das?* (Djevalite, fianite, zirconia—what is it?) Z.Dt.Gemmol.Ges., 28, 1, 3-20, 8 diagrams, 5 figs, bibl, 1979.

The following is the author's summary. Cubic stabilized zirconia appears to become the most important material to imitate diamond. The high-temperature cubic phase of ZrO₂ can be stabilized at room temperature via the incorporation of certain stabilizing oxides such as Y₂O₃ or CaO. It is deduced from the pertinent sections of the phase diagrams that the phase transformation temperatures are sub-

*See Scarratt (K.), Investigating the visible spectra of coloured diamonds, J.Gemm., XVI (7), 433,—Ed.

stantially lowered by the stabilizers, whereby transformation into a non-cubic modification is prevented. Single crystals up to $8 \times 3 \times 3$ cm are grown by means of the skull melting method. This technique uses a water-cooled crucible which contains the inductively heated melt. A layer of unmolten material protects the container walls from melt attack. Crystallization is initiated by slow cooling. The crystallized product is marketed by different producers who have given the products special trade names, the best known being djevalite, fianite and zirconia. E.S.

DIRKS (J.). *The renaissance of the art of scrimshaw*. *Gems & Gemology*, XVI, 5, 142-6, 16 figs in colour, 1979.

J. Dirks is an artist of considerable skill who has revived the old whalers' art of engraving on bone and ivory, using, perhaps, more colour than in the antique pieces. In these days of animal conservation it is just as well that she emphasizes that only fossil ivory is used. R.K.M.

DODSON (J. S.). *The brilliance, sparkliness and fire of several diamond simulants*. *Optica Acta*, 25, 8, 701-5, 4 figs, 1978.

Using a computer program to assess the optical goodness of a range of diamond simulants, in terms of their brilliance, 'sparkliness' and fire, it is shown that strontium titanate is better than diamond, and that for the round brilliant-cut style, the degree of optical goodness is proportional to the refractive index of the material. It is, however, acknowledged in the article that public opinion favours whiter 'sparkles', and that the sparkle of strontium titanite is considered by many to be vulgar. Cubic zirconium oxide (called ZOC in the article) is claimed to be the best of the more acceptable simulants, although according to the computer analysis its general brilliance, sparkliness and fire are lower than those of strontium titanite and diamond. No comparative constants are given for the hypothetical suite of materials simulated by the computer, which comprised strontium titanate, YAG, GGG, synthetic spinel, plus General Electric's Yttralox and two glasses, TiF6 and BK7, made by the Schott optical company. P.G.R.

DODSON (J. S.). *The brilliance, sparkliness and fire of some modifications to the round brilliant cut diamond style*. *Optica Acta*, 25, 8, 693-99, 11 figs, 1978.

The difficulty of polishing 57 facets on a diamond having a girdle diameter in the region of 2mm has prompted the writer to investigate several simplifications of the brilliant-cut design. By using a computer program to assess the brilliance, 'sparkliness' and fire of these modifications, a conclusion is reached which states that diamonds with more than eight crown and pavilion facets are acceptable, but inferior, substitutes for the full brilliant-cut stone. P.G.R.

DODSON (J. S.). *A statistical assessment of brilliance and fire for the round brilliant cut diamond*. *Optica Acta*, 25, 8, 681-92, 19 figs, 1978.

In assessing the optical goodness of the diamond brilliant cut, the writer establishes criteria of brilliance, fire and 'sparkliness' (the latter coined term being oddly at variance with the academic language of the article, and referring to the scintillation of the diamond produced by its movement). In order to quantify these qualities, the diamond is assumed to be spinning about its axis and surrounded by a hypothetical sphere, centred on the table facet. The optical qualities of brilliance,

fire and sparkliness are represented by the statistical properties of the intensity distribution of reflected light on the sphere. The representation is purely mathematical, and is derived by calculating the final positions and intensities on the sphere of rays reflected from the diamond's facets. The effect of fire is arrived at by tracing the rays at various refractive indices. Unfortunately, the position of the incident light on the diamond is lost in the approximation process, and it is not therefore possible to take account of visible girdle or dark table effects.

A computer program was written to model the hypothetical spinning diamond and its surrounding sphere, and to permit rapid assessment of the effects on the diamond's brilliance, fire and sparkliness, of varying the pavilion-half factor (i.e. the ratio between the lengths of the pavilion main and half facets), the spread of the table, and the pavilion angle. The results confirm that the traditional ideal brilliant cuts for diamond are satisfactory, but indicate that an equally attractive, if not improved, appearance could be obtained with at least one other set of proportions. To exploit this, a new design is proposed with a table spread of 40-50%, a crown height of 15%, a pavilion angle of 53°, and a pavilion-half factor of 0.5. The article contains no mention of any attempt to test these proportions in practice.

The project was supported by the Diamond Trading Company (Pty) Ltd. P.G.R.

FRANCO (R. R.). *As substâncias naturais e artificiais usadas como imitação do brilhante*. (Natural and artificial substances used as diamond imitations.) *Gemologia*, 21, 41/42, 57-63, 1975.

Reviews the 'classic' diamond imitations, including composites, M.O'D.

FUQUAN (W.). *Precious stones found in China*. *Lapidary Journal*, 33, 3, 694-6, 2 figs, 1979.

The People's Republic of China is rich in gemstones. These include diamond, ruby, sapphire, chloromelanite, topaz, amber, various kinds of quartz and turquoise. M.O'D.

GEORGE (C. D.). *Cultivation of pearl shell and pearls in the Indopacific region*. *Lapidary Journal*, Part 1, 33, 1, 72-84, 5 figs (1 in colour); Part 2, 33, 2, 48, 498-517, 5 figs, 1978.

The first two parts of a series intended to cover the history and current workings of pearl and pearl shell in the Indopacific region. The first paper lists the pearl-making oysters, the main shell fisheries and the early production of the various countries in the area. The second part continues the account begun in the previous issue with a special note on the discovery of the spherical pearl technique. M.O'D.

GILSON (P.). *Shop practice for gem cutting*. *Lapidary Journal*, 33, 3, 826-8, 1979.

Details are given of the preferred media for polishing and cutting stones manufactured by the author. M.O'D.

GREENSPAN (J.). *A collection of Chinese carved jade*. *Lapidary Journal*, 33, 3, 668-90, 8 figs (4 in colour), 1979.

Describes and illustrates specimens from the jade collection of the author. All are carved and dates given. M.O'D.

HANNEMAN (W. W.). *Refractive index determination by the method of B. W. Anderson*. Lapidary Journal, **33**, 3, 800-2, 8 figs, 1979

This involves immersion and observation of the characteristic shadow bordering the stone. Examples are illustrated. M.O'D.

KELLY (R. B.). *Rhodonite or pink jasper*. Australian Gemmologist, **13**, 9, 291-5, 1 map, 1979.

An interesting account of two materials of similar appearance from localities in the Coomera District of Queensland, and of the investigations which identified them respectively as jasper and rhodonite, the latter with high silica content. Of particular interest is the coincidental mineral history revealed quite casually in this and similar Australian papers. The rhodonite sites were first worked as rich gold deposits. Text refers to a second map which is not published. R.K.M.

KERR (B.). *Fashioning cubic zirconia*. Gems & Gemology, **XVI**, 5, 155-7, 3 figs in colour, 1979.

Each new material presents problems to the cutter. This paper suggests solutions to those arising with cubic zirconia. Problems mainly with polishing. Work dry on ceramic lap with 'spray' diamond, at slow speed, wiping cutting residue away to avoid scratching. Helpful paper for amateur and professional lapidary alike. (Here there has been some trouble with cleavage under dopping heat.) R.K.M.

KONNO (H.). (A report of the 11th General Meeting of the International Mineralogical Association.) J. Gemm. Soc. Japan, **6**, 1/2, 29-33, 7 figs, 1979. (Japanese with English summary.)

Describes a visit to Lake Baikal, Siberia, and gives notes on charoite. M.O'D.

LESH (C.). *Quartz: myth and magic, science and sales*. Gems & Gemology, **XVI**, 6, 174-8, 1979.

A strange paper, attempting to apply logic to superstition and to equate the radio frequency crystal with the powers of the medicine man; the helix of quartz structure with the spiral (not helical!) tombs of Celts; and Stonehenge and other megalithic circles with the quartz analogue watch of today. R.K.M.

MALLAS (A. A.). *Kashan—creators of beauty*. Lapidary Journal, **33**, 6, 1302-4, 4 figs, 1979.

Describes the processes used for manufacturing ruby by the flux-melt process and its subsequent placement on the market. M.O'D.

MIURA (Y.). (Iridescence in alkali feldspar.) J. Gemm. Soc. Japan, **5**, 3, 15-25, 17 figs, 1978. (Japanese with English summary.)

From analyses made with EPMA and observations with the electron microscope it is seen that iridescent alkali feldspars show exsolution lamellae structures which produce the iridescence with compositions from Or(thoclase)₂₀ or Or₇₀. The colour changes from blue to yellowish-orange as the orthoclase content increases. A whitish blue colour is produced with compositions from Or₂₅ to Or₃₅. Iridescence therefore is the result of interference and scattering according to the state of the lamellar boundaries. M.O'D.

MOACYR (J.), COUTINHO (V.), SVISERO (D. P.). *Nota sobre algumas ocorrências de variscitas brasileiras*. (Note on some Brazilian variscite occurrences.) *Gemologia*, **21**, 41/42, 52-6, 5 figs (4 in colour), 1975.

Brazilian variscite has been found in Rio São Tomé near the frontiers of Mato Grosso and Amazonas; further specimens have been found in the pegmatite of Proberil, close to Linópolis, Minas Gerais. M.O'D.

MUIJE (P.), (C. S.), (L. E.). *Colourless and green grossularite from Tanzania*. *Gems & Gemology*, **XVI**, 6, 162-73, 6 figs, 1979.

A thorough investigation of these gems. Colourless is by far the rarer, but of less interest to trade. These were colour-graded against diamond although tints of grossularite were green while those of diamond were yellow. Green stones in a range from near colourless to deep green were analysed by x-ray spectrum analysis, establishing that all conformed closely to the ideal grossularite formula. Increases in V_2O_5 , and to a much smaller extent of Cr_2O_3 , were noted as the colour deepened, the latter being undetected in near colourless and lighter shades of green, suggesting that this colour is almost entirely due to vanadium. Single RI 1.731; SG 3.62; various inclusions, none of which is characteristic. R.K.M.

NASSAU (K.). *An examination of the new Gilson 'coral'*. *Gems & Gemology*, **XVI**, 6, 179-85, 5 figs, 1979.

An investigation of Gilson coral, undertaken with Dr Nassau's usual care, which assigns the substance, on several grounds, to an imitation category rather than a synthetic one. About eight shades, from almost white to deep ox-blood are available and four of these were examined in detail. The imitation is less dense (2.44) than natural coral (2.6+), the former proving to be absorbent on prolonged immersion, and more easily breakable than the natural material. Presence of silica and iron noted in Gilson coral, not found in natural. It also lacks normal structural veining often seen in the natural product. R.K.M.

NELISEROVÁ (E.). (Evaluation of synthetic diamond quality on the basis of crystallography and dynamic strength.) *Zborn. Slov. Nár. Múz.*, **71**, 29-77, 20 figs, 1977. (In Slovak, with Russian and German summaries.)

The aim of this work is to find out whether a relation (functional dependence) exists between the morphological quality of synthetic diamonds and their dynamic strength. It is possible to compare mutually both these parameters as they characterize a particular physical quality of a representative (complex) of synthetic diamonds, thus both have a statistical character. From comparison of index numbers (characterizing crystallographical quality of diamonds) and Friatest numbers (characterizing dynamic strength) by means of regressive analysing methods, logarithmic function dependence has been established. Š.D.

O'DONOGHUE (M.). *A gem tour to Scandinavia and the USSR*. *Lapidary Journal*, **33**, 6, 1416-22, 4 figs, 1979.

A visit to the major gem and mineral locations in Norway, Sweden and Finland is described with additional notes on visits to museums in the U.S.S.R.

(Author's abstract) M.O'D.

O'DONOGHUE (M.). *A study in crystal structures of gemstones*. Gem World, 6, 2, 33-46, 1979.

Coordination numbers, close packing, bonding and common structures of some gem materials are described and explained in this compilation by the publishers of *Gem World* from several of the author's *Gemmological Newsletters*.
(Author's abstract) M.O'D.

ORLOV (Yu. L.). *Polygenesis and typomorphism of diamond in kimberlite deposits*. International Geology Review, 21, 8, 975-81, 1979.

Investigation has shown that there are different and classifiable types of diamond crystal occurring in kimberlites and it is suggested that different conditions of crystallization apply to each variety. This study is confined to diamonds from xenoliths in deep-seated rocks.
M.O'D.

REAM (L. R.). *The Thomas Range, Wah Wah mountains and vicinity, western Utah*. Mineral. Record, 10, 5, 261-78, 34 figs (5 in colour), 1979.

The areas described and mapped include sites for red manganiferous beryl and for topaz, both of which are illustrated. Red beryl occurs in rhyolites and is found either as clusters of prismatic crystals along fracture-controlled veins or as tabular crystals in vugs.
M.O'D.

ROBERTSON (A. C. D.). *Porous Gilson synthetic black opal*. Australian Gemmologist, 13, 9, 297-9, 6 figs in colour, 1979.

A report on a Gilson stone from an unusually porous batch (cf. findings of Jobbins *et al.*, J. Gemm., 1976, XV, 2, 73-5.).
R.K.M.

ROLANDI (V.). *Considerazioni particolari sul sistema DIN 6164*. (Special consideration of the system DIN 6164.) La Gemmologia, 4, 3/4, 42-8, 2 figs, 1978.

The DIN 6164 system is one of the West German standards; it provides a method of measuring colour and has some application to gem description.
M.O'D.

RUSKONÉ-PONCET (E.). *Les principaux centres de taille des pierres précieuses et fines dans le monde*. (The chief cutting centres of fine and precious stones in the world.) Revue de Gemmologie, 59, 7-9, 3 figs (1 in colour), 1979.

Short notes on Idar-Oberstein, Jaipur and centres in Thailand are given with historical background.
M.O'D.

SALA (J. della), TUCCIO (R.). *Two interesting treated diamonds*. Gems & Gemology, XVI, 4, 125-6, 2 figs, 1978.

Two dark tourmaline-green diamonds showed no 'umbrella' markings, nor absorption spectra for treated stones. Scintillograph test also negative. They were identified as radium-treated by exposure to light-tight photographic film. (Fig. 1 shows a strangely uncharacteristic sharp eight-spot 'autoradiograph' for such a treated stone and in abstracter's opinion this stone may well have been naturally coloured. Similar sharp images have been seen when a stone has been placed on film while using the wrong safe-light. Autoradiographs are not usually sharply patterned in this way.)
R.K.M.

SCHÄFER (W.). *Auf den Spuren der Garimpeiros: Smaragdsuche in Brasilien.* (On the tracks of the garimpeiros—emerald-seeking in Brazil.) *Mineralien Magazin*, 3, 4, 213-18, 7 figs in colour, 1979.

Describes the work of emerald miners in the Carnaiba area of Bahia, Brazil.

M.O'D.

SCHÄFER (W.). *Glücksstein des November. Auf einer brasilianischen Topasmine.* (November birthstone: from a Brazilian topaz mine.) *Mineralien Magazin*, 36, 323-6, 6 figs in colour, 1979

Describes a visit to a number of topaz mines in the Ouro Preto area of Minas Gerais, Brazil. A map is included.

M.O'D.

SCHMETZER (K.), BANK (H.). *Bluish-green zoisite from Merelani, Tanzania.* *Gems & Gemology*, XVI, 4, 121-2, 1978.

Mainly concerned with pleochroic changes in blue zoisite under heat treatment. Colour change and reduction of pleochroism is due to the removal of an absorption band in the blue. This causes the Z crystallographic direction to yield blue instead of yellow-brown. Bluish-green zoisite has a different pleochroism but also moves towards blue when heated.

R.K.M.

SCHMETZER (K.), BARTELKE (W.). *Schleifwürdiger Diaspor aus der Türkei.* (Cuttable diaspor from Turkey.) *Z.Dt.Gemmol.Ges.*, 28, 2, 69, 1979.

Diaspor is a small constituent of bauxite; it is a rhombic crystal, leafy or scaly; sometimes also needles occur. The crystals are colourless, sometimes grey, yellow-brown or red (when containing Mn). Larger crystals from Chester, Mass., U.S.A., were described in 1865 by Shephard, in 1886 by Dana and in 1964 by Guillemin; a large crystal 30 × 40cm from this locality is to be found in the Harvard University collection. The diaspor was given to the authors in 1977: tabular, light yellow, transparent and of up to 8cm in length, these cleavage pieces were nearly colourless. The material is very brittle and difficult to cut, but faceted stones of up to 0.25ct were produced.

E.S.

SCHMETZER (K.), KRUPP (H.). *Neue Beobachtungen en Edelsteinen aus Ostafrika.* (New observations of gemstones from East Africa.) *Z.Dt.Gemmol. Ges.*, 28, 1, 35-37, bibl., 1979.

Three gemstones are discussed. Especially large and clean spessartines from the Taita Hills in Kenya were up to 5cm large and owe their intensive orange-red to coloration by Mn²⁺. Smaragdite is chrome-containing actinolite from Tanzania. Finally the authors describe an individual cabochon with strong cat's-eye effect, 3.2ct, light green, which was found to be diopside.

E.S.

SCHMETZER (K.), OTTEMANN (J.), BANK (H.), KRUPP (H.). *Transparent bluish-green kornrupine from East Africa (Kenya and Tanzania).* *Gems & Gemology*, XVI, 4, 118-20, 1978.

A report in detail on bluish-green and blue kornrupine from these localities, some of which have been offered as tourmalines, garnets or sillimanites. Colour is due to iron, chromium and vanadium. Blue stones contain more chromium, while vanadium is responsible for the greener specimens. RI can be summarized as 1.662-1.674, DR 0.012, strongly negative in sign.

R.K.M.

SCHMETZER (K.), OTTEMANN (J.). *Kristallchemie und Farbe Vanadium-haltiger Granate*. (Crystal chemistry and colour of vanadium-bearing garnets.) Neues Jahrbuch für Mineralogie, **136**, 2, 146-68, 1979.

Absorption spectra of vanadium-bearing garnets, including pyrope, spessartine, grossular and goldmanite, include two strong bands in the visible. These are attributed to crystal field transitions of V^{3+} in octahedrally-coordinated positions in the garnet structure. M.O'D.

SNOW (J. J.). *The use of the Figure-O-Scope in gemmology*. Australian Gemmologist, **13**, 9, 301-6, 10 figs (3 in colour), 1979.

At last a description of this curiously named instrument mentioned more than once in past issues. Basically a much simplified polarizing microscope made specifically to give interference figures with a minimum of trouble, it employs a spherical objective lens and divergent light. It will also detect pleochroism. R.K.M.

SUHNER (B.). *Infrarot-Spektren in der Gemmologie*. (Infrared spectra in gemmology.) Z.Dt.Gemmol.Ges., **28**, 2, 55-68, 8 graphs, bibl., 1979.

The author discusses the uses of infrared spectroscopy as an additional method for the identification of gemstones; the reflection method is especially applicable, as it does not destroy the specimen and can be used for set stones. It is also preferable to the absorption method as the spectra obtained are more definite as shown by the illustrations, which represent graphs obtained for sodalite, quartz, tourmaline, garnet, charoite, rhodonite and pyroxmangite. It is not always easy to compare directly the absorption and reflection spectra. Comparative reflection spectra should be collected as well as the absorption data and it would be of advantage if these data could be added to the results of examination of new materials. E.S.

SUNAGAWA (I.). (Activities in gemmological studies in Socialists' [*sic*] countries.) J. Gemm. Soc. Japan, **6**, 1/2, 3-21, 19 figs, 1979. (In Japanese with English summary.)

An account of some of the proceedings of the 11th General Meeting of the International Mineralogical Association held in Novosibirsk, Siberia, U.S.S.R. Details are given of some synthetic products including emerald, tourmaline and alexandrite. M.O'D.

SUNAGAWA (I.), HAMADA (M.). (Lattice images of synthetic emerald.) J. Gemm. Soc. Japan, **5**, 3, 11-14, 2 figs 1978. (In Japanese with English summary.)

Two-dimensional lattice images of flux-grown synthetic emerald and two electron micrographs of lattice images on (0001) and (10 $\bar{1}$ 0) are shown. M.O'D.

SUPERCHI (M.). *Introduzione alla quantificazione del colore*. (Introduction to colour quantification.) La Gemmologia, **4**, 3/4, 31-41, 7 figs, 1978.

The colour measurement systems of DIN, Rösch and others are introduced and compared. M.O'D.

SVISERO (D. P.). *As variedades gemológicas de berilo*. (The gem varieties of beryl.) Gemologia, **23/24**, 45/46, 67-71, 1 fig, 1978.

The types and occurrences of beryl of gem quality in Brazil are discussed. M.O'D.

SVISERO (D. P.), HARALYI (N. L. E.). *O diamante princesa de estrela do sul*. (The diamond 'Princess of Estrela do Sul'.) *Gemologia*, **23/24**, 45/46, 45-53, 4 figs, 1978.

This diamond weighs 82.25ct and was found in a placer of Bagagem River in south-west Minas Gerais, Brazil. M.O'D.

SVISERO (D. P.), POROLA (A. R. A.). *As mudanças de cor do espodumênio*. (Change of colour in spodumene.) *Gemologia*, **23/24**, 45/46, 59-60, 1978.

The colour of spodumene can be altered by irradiation; green, pink and colourless varieties are known. M.O'D.

SVISERO (J. B. G.), (D. P.). *Geología de los depositos diamantíferos de la parte noroccidental de la Guayana venezolana*. (Geology of the diamond deposits of the north-western part of Venezuelan Guayana.) *Boletín de Geología, Dirección General Sectorial de Minas y Geología, Venezuela*, **13**, 24, 3-46, 26 figs, 1978.

Diamond has been discovered at Quebrada Grande, a tributary of the Guaniamo River, district of Cedeño, state of Bolívar, Venezuela. Forsterite, enstatite and chrome pyrope are characteristic inclusions. It is suggested that the diamonds originate in kimberlite-type ultramafic matrices. M.O'D.

SWEANEY (J. L.). *Fire agates in Deer Creek*. *Gems & Gemology*, **XVI**, 5, 130-41, 19 figs in colour, 1979.

Excellent account of a gem agate little known in Britain. These are translucent botryoidal chalcedonies containing micro-thin opaque layers of iridescent iron oxide. These give rise to colour, due to interference, which can vary through the entire spectrum in different specimens. The layers follow the contours of the host mineral, and cutting consists of grinding away all but a thin protective layer and so calls for considerable skill, each stone being cut as an individual and unique exercise in shaping. Colour photographs by Havstad (M. R.) are particularly attractive. Deer Creek (Arizona), California and Mexico all produce this type of agate, but the writer considers the first of these to be the best source. R.K.M.

TAKUBO (H.), KITAMURA (Y.), NAKAZUMI (Y.), KOIZUMI (M.). (Internal textures and growth conditions of flux-grown emeralds from USSR.) *J. Gemm. Soc. Japan*, **6**, 1/2, 22-8, 16 figs, 1979. (In Japanese with English summary.)

Emeralds showed veil-like secondary inclusions along the curved surfaces of tension cracks, other veil-like inclusions filling pores in a mosaic structure; silk-like inclusions intersecting the *c*-axis obtusely were also cited. Surface growth markings are illustrated. M.O'D.

TAKUBO (H.), MUGURUMA (A.), KOIZUMI (M.). (Relation between internal textures and growth conditions of flux-grown emerald.) *J. Gemm. Soc. Japan*, **4**, 3-12, 3 figs, 1977. (In Japanese with English summary.)

Emerald crystals were grown in the melt composed of $\text{Li}_2\text{O}-\text{MoO}_3$ flux and gel powder of $3\text{BeO}.\text{Al}_2\text{O}_3.6\text{SiO}_2$ composition using several temperature programmes. Their internal textures were observed under the polarizing microscope and correlated with the growth conditions such as temperature and degree of supersaturation. Development of zonal structures, optical anomalies and domain structures are

attributed to the temporary fluctuation of temperatures during cultivation. Rapid growth on the non-crystallographic rough surfaces tends to form nail-like inclusions. Prolonged cultivation at a fixed high temperature leads to the formation of feather or lace-like inclusions which are characteristic of the flux-grown emeralds in the market. These results suggest that more perfect crystals of emerald can be obtained from the flux-melt both by slow cooling technique and by strict temperature control. I.S.

USHIO (M.). (Appearance and disappearance of crystal faces of emerald during crystal growth by V_2O_5 flux method.) J. Gemm. Soc. Japan, **4**, 51-9, 5 figs, 1977. (In Japanese with English summary.)

Both spherical seeds and cubic seeds, cut parallel to crystallographic and non-crystallographic orientations were prepared from natural beryl crystals. These were used as seeds in growth of emerald from V_2O_5 flux, to investigate appearance and disappearance of crystal faces during growth. All experiments were carried out at 1050°C for growth temperature and 10°C for Δt . When a spherical seed of 10mm was used, (10 $\bar{1}$ 0) and (0001) appear at the earliest stage (before 5 h), followed by the appearance of (11 $\bar{2}$ 0) (10 $\bar{1}$ 1), (11 $\bar{2}$ 2), (11 $\bar{2}$ 1), (20 $\bar{2}$ 1), (21 $\bar{3}$ 1), and (31 $\bar{4}$ 1) after 8 h; after 10 h, u , v , and n faces disappeared. A small prism face (31 $\bar{4}$ 0) was observed between m and a faces, and soon disappeared as growth proceeded; o , s , and p faces disappeared after 200, 250, and 275 h, respectively. The final morphology after 275 h was hexagonal prism consisting of only (0001) and (10 $\bar{1}$ 0). In the case of cubic seed of 10mm cut parallel to non-crystallographic orientation, c (0001), m (10 $\bar{1}$ 0), and a (11 $\bar{2}$ 0) faces appeared at first (after 5 h), followed by the appearance of p , s , and o faces after 24 h. The latter two faces disappeared after 165 h and the former face after 270 h; the final form was again hexagonal prism. In the case of cubic seed of the same size cut parallel to crystallographic orientations, the faces parallel to the cut plane appeared and developed well at first, but u , v , and n faces, which are all inclined at higher angles to the c face, disappeared after 100 h; o and s faces remained after 300 h and p face after 500 h. In any case, the final forms were similarly hexagonal prismatic form consisting of c (0001) and m (10 $\bar{1}$ 0) faces. I.S.

VARGAS (G.), VARGAS (M.). *Emeralds on a cow pasture*. Lapidary Journal, **33**, 2, 594-600, 16 figs, 1979.

An account of emeralds and other gemstones found during a trip to Brazil. M.O'D.

VOSKRESENSKAYA (I. E.), IVANOVA (T. N.). *Issledovanie turmalinov polychennykh metodom sinteza*. (Study of synthetically produced tourmaline.) Trudy Mineralogicheskogo Museya A. E. Fersmana, **24**, 20-30, 3 figs, 1975. (In Russian.)

Tourmaline crystals up to a few mm in length have been synthesized at temperatures ranging from 750 - 800°C and at pressures of 1000-2000 atmospheres. Constituents are Al_2O_3 , SiO_2 and $MgCl_2 \cdot nH_2O$. Dark blue, brown, black and dark green crystals were obtained with various dopants which included Cr, Fe, Fe-Li, Co and Ni. Drawings of crystals are given. M.O'D.

WILSON (A. F.). *Why sapphires from Sri Lanka differ from those from Australia.* Australian Gemmologist, **13**, 10, 315-17, 1979.

Explains differences in colour, zoning, silk content and mineral and fluid inclusions by the fact that Sri Lankan sapphires are the product of a metamorphic environment, while Australian sapphires occur in basalt, a volcanic igneous rock formed at high temperatures and very great depths. R.K.M.

ZEITNER (J. C.), MILLSON (H. E.). *Another look at agates, part 1.* Lapidary Journal, **33**, 2, 478-86, 15 figs in colour, 1979.

A general introduction to agates with illustrations of some examples from the U.S.A., Brazil and Mexico. M.O'D.

ZEITNER (J. C.). *An exceptional euclase.* Lapidary Journal, **33**, 6, 1282-8, 7 figs (4 in colour), 1979

A rich green euclase weighing 18.29ct has been discovered in a weathered pegmatite dike in the Ouro Preto area of Minas Gerais, Brazil. It has been faceted and presented to the National Museum of Natural History, Smithsonian Institution. M.O'D.

Aus der Untersuchungspraxis. (From the Laboratory.) Z.Dt.Gemmol.Ges., **28**, 2, 73-81, 1979.

H. Bank discusses the diaspore from Turkey, which in its cut state is pale green; H. Bank and V. Zwetkoff examined a lot of synthetic emeralds, which were colourless or pale pink beryls covered with Lechleitner emerald and showed a relatively wide variation in the RI, depending on the type of beryl used and also the Cr-content of the covering material. H. Bank relates an incident when cordierite and amethyst could not be distinguished as the optical properties are very near to each other. Lastly H. Bank and A. Frere warn about dangers when examining set stones. E.S.

Colección de gemas del I.G.E. (The gem collection of the I.G.E.) Boletín del Instituto Gemológico Español, **19**, 17-20, 6 figs in colour, 1979.

Some stones in the collection of the Instituto Gemológico Español are illustrated with brief comments. M.O'D.

Fake Sri Lankan sapphires cause prices to fall. Retail Jeweller, **17**, 423, 12, 1979.

A report emanating from Sri Lanka on the effect of Thai purchases of so-called Geuda sapphires (described as milky greyish-green stones), which are then smuggled to Thailand and heat-treated to a better blue. This practice is said to be depressing the prices obtained for blue stones of natural origin. These are no doubt stones similar to those discussed by R. Crowningshield in his report from the G.I.A. New York Lab in *Gems & Gemology* (see abstract above). (Such stones are also being offered on the London market but so far their heat-treated nature has been disclosed by the sellers. They are not as pleasing as the natural Sri Lankan sapphire in colour.) R.K.M.

NOTE: *Wahroongai News* is the monthly magazine of the Queensland Branch of the Gemmological Association of Australia: the price (in Australia) is 5c.

BOOK REVIEW

AUBERT (G.), GUILLEMIN (C.), PIERROT (R.). *Précis de Mineralogie*. (Compendium of Mineralogy). Masson, Paris, 1978. pp.xiv, 335. Illus. in black-and-white and in colour. Price on application.

This book is chiefly notable for the fine series of coloured photographs and for simplicity of style. The customary introductory chapters on theoretical and determinative mineralogy are followed by a survey of the commoner minerals and by a final chapter 'Elements of gemmology' by H.-J. Schubnel. M.O'D.

BIXBY (M. A.). *A catalogue of Utah minerals and localities with descriptive notes for collectors*. Reprint no. 60 of Utah Geological and Mineralogical Survey, Salt Lake City, 1959. pp.32. \$1.00.

An alphabetical list of the minerals found in the State of Utah, including topaz, the red variety of beryl and several rare minerals. Some historical notes are given and a list of locations by county. M.O'D.

BLATCHEY (W. S.). *Gold and diamonds in Indiana*. Geological Survey of Indiana, Bloomington, Indiana, no date. (Reprinted from the 27th Annual Report of the Indiana Dept of Geology and Natural Resources.) pp.47. Price on application.

The gold and occasional diamonds found in the State of Indiana are detailed in this short county-by-county survey by a distinguished early geologist. Speculations on the origin of the diamonds are included. M.O'D.

DIETRICH (R. V.). *Minerals of Virginia*. Virginia Polytechnic Institute, Blacksburg, 1970. pp.vii, 325. Illus. in black-and-white. \$4.00.

Forming Research Division Bulletin 47 of the Institute, this useful guide is the eighth list of Virginia minerals to appear; it is also the first one in which the minerals are listed alphabetically. The standard guide and written by a well-known authority. M.O'D.

FIELD (J. E.), (ed.). *The properties of diamond*. Academic Press, London, 1979. pp.xiv, 674. 1 colour plate. £32.50.

This is intended to be a successor to Berman, *The physical properties of diamond*, published in 1965. Many additions to the science of diamond have been made since that date and are reflected here, notably reports on the synthesis and optical spectra of the stone. The book is divided into parts covering the solid state (including work on absorption spectra, thermal and electrical properties, cathodoluminescence and nuclear properties); theoretical work, surface studies, mechanical experiments including wear strength and fracture, growth, geology and industrial uses. Readers will find most to interest them in the sections on optical properties and colour centres, and it is worth noting that there is still no certainty as to the true nature of the origin of platelets; whether these are all nitrogen or whether they are all the nitrogen is still the subject of study. A most useful chapter deals with diamond inclusions which are related in most cases to particular mines of origin; reports of rutile and kyanite inclusions are mentioned, as they have been in other works. Remarks on diamond synthesis show that two problems have to be overcome before

commercial work is feasible; one is preferential graphite nucleation, the other slow, surface-area-dependent growth rates. M.O'D.

GIRARD (R. M.). *Texas rocks and minerals: an amateur's guide*. Bureau of Economic Geology, University of Texas, Austin, Texas, 1976. pp.vi, 109. Illus. in black-and-white. Price on application. (Bureau of Economic Geology, Guidebook 6.)

Although Texas is not one of the more richly-mineralized states of the U.S.A., there are still some interesting and attractive specimens to be found. They include celestine from the Austin area, gypsum from Terlingua, garnets in central and west Texas and at least one occurrence of opal with a play of colour. Minerals, rocks and rock-types are arranged in one alphabetical sequence. M.O'D.

HARSHAW (M. R.). *In search of the scarce green hiddenite and the emeralds of North Carolina*. Hexagon Company, Asheville, N.C., 1974. Illus. in black-and-white and in colour. \$2.25.

This short guide is intended for use by those visiting the famous gem-producing areas in Alexander County, North Carolina. Anecdotes, history and maps accompany details of present-day production and notes on the stones. M.O'D.

HURLBUT (C. S., Jr), SWITZER (G. S.). *Gemology*. John Wiley & Sons, New York, 1979. pp.XIV, 254. 350 Figs, 12 colour plates. \$29.25/£13.50.

The authors, both of whom hold mineralogical appointments of importance in America, have undertaken a textbook with 'a concise yet comprehensive and systematic treatment'. In this they have succeeded, with certain reservations, although their publishers' idea of a textbook format is biased a little towards the 'coffee-table' presentation which the authors decry. But the reviewers dispute the claim made on the first page of the preface that this is the first such book produced this century.

Inevitably, parts—particularly those chapters devoted to mineralogy and crystallography—may be thought over-comprehensive, and one wonders at the inclusion of so much basic material in a work which seeks to simplify crystal morphology to the point where the dome form is described as a horizontal prism and triclinic crystals are said to consist entirely of pinacoids. There have been many different classifications of crystals, some too complex, others over-simplified. The present one seems to fall into the latter class. Polyhedral diagrams of atom lattices appear frequently but, without adequate explanations in the text, convey very little.

On the gemmological side the book is concise and occasionally almost dismissive. The microscope and spectroscope are each given a scant five pages; inclusions are dealt with in three. It seems to be implied that an absorption spectrum is always an identical black line reversal of the emission spectrum of a substance. This, of course, is not true if applied to our type of absorption spectrum. The effect of reversal can be seen only when bright lines emitted by an incandescent substance pass through a gas, as in the case of the Fraunhofer lines in the spectrum of sunlight. Otherwise an absorption spectrum bears no relation to the far more complex emission spectrum of a substance. The absorption spectra of gems are not black line versions of their bright line emission spectra.

A diagram of the electromagnetic spectrum follows the conventional practice of

showing long waves to the left and short to the right. But absorption spectra diagrams are reversed, with short to the left and long to the right. Since this is a textbook primarily for American consumption it can hardly avoid conforming with the G.I.A. practice, which results from their early adoption of a Beck spectrometer which, unfortunately, reverses the spectrum in this way. Text references quote long waves first, however, and there is some merit in the fact that these are in Ångström Units and not in the newfangled and scarcely necessary nanometres!

One recognizes that the refractometer is perhaps not a 'mineralogist's instrument', but to say that it is possible to read the dispersion of a stone by using white light with this instrument is an error unworthy of the book. One of the first things one learnt when studying gemmology was that the position of the shadow edge seen when using white light depended on the difference in refraction between the stone and the optically dense glass of the instrument. Because the latter has very high dispersion, violet light gives a substantially *lower* RI reading than that obtained with red light. For this reason all normal refractometers are calibrated for one standard wavelength only, that of the sodium emission line. Any attempt to read for other wavelengths must give false results and it is *not* possible to determine dispersion by direct reading.

Also it is stated that, on rotation of a test stone, both α and γ readings will, at some point in rotation, coincide with the reading for β . Unless the test facet is exactly parallel with the optic axial plane of the crystal, this again is not true. For any other test facet only one of the two medial readings will reach the value for β , and a second series of readings, taken from another facet, must be obtained in order to determine which of the two medial values is the same for both facets. This reading will be the RI value of β .

Contrary to the text, the spinel refractometer and, indeed, all Rayner refractometers for many years, have used an optically dense *prism* in place of the earlier and more expensive hemisphere; a breakthrough in design resulting directly from the work in the 1930s of Anderson and Payne on suitable alternative materials for this essential part of the instrument. They have never used a hemicylinder. Also there is no reason why a contact liquid of RI higher than that of the dense prism should not be used, although the text suggests otherwise.

Chapter 13, Descriptive Gemology, is by far the longest, running to about 100 pages. Gems are divided into Important; Less Important; Others and Ornamentals; Organics and Synthetics. Stones in the first section are dealt with in a somewhat arbitrary order of commercial/scientific importance. In the other sections the order is alphabetic, but species headings, in contrast with half inch high chapter headings (each splendidly isolated in a blank half-page), are scarcely distinguishable from paragraph sub-headings, making the finding of a given species a little difficult.

Synthetic lapis lazuli is omitted, although it appeared on the market before cubic zirconia, which is included in the book. In connexion with the latter, why is the infrared reflectometer omitted? Under dyed jadeite it is not sufficient in a textbook to say 'identification may also be made with the spectroscope' without indicating the absorption spectrum to be looked for. Axinite is said to have 'no symmetry'; it has, in fact, centro-symmetry. We are told that its gem colours are blue, yellow, violet or green. In our long experience of handling rare gems we have seen only clove-brown, plum-red and one solitary aquamarine-blue, which is mentioned separately in the text. Painite, at the time the book was written, 'existed' in *two* crystals, both in the

British Museum (Natural History). Gilson synthetic emeralds are made in France, not in Switzerland.

A final short paragraph on Identification Procedure omits the very valuable use of the absorption spectrum. Its last sentence certainly says 'In certain especially difficult cases use of spectroscopic and x-ray diffraction methods may be required.' But this must refer to emission spectroscopy involving vaporization of material. Absorption spectroscopy is often a very simple and decisive method for use early in an identification procedure.

Extensive and elaborately cross-referenced tables of RI and SG are listed. Some values are at variance with those already well established, e.g. DR of tourmaline (average) 0.025; SG of corundum 4.02. In uniaxial species the variable index is underlined. No indication is given that both RIs vary in biaxial species. It might have been a better idea to underline the invariable index and leave the other values for both uniaxial and biaxial free to vary. Lists of the World's largest Rough and Polished Diamonds seem a little out of place in a book of this kind.

There are two indexes, one by subject, which is occasionally inaccurate in page reference, the other by gem species, which contains a useful summary of the essential facts for each stone.

The authors' manuscript was checked by independent readers who should have noted some of the errors quoted above. Further, Lester B. Benson, the brilliant G.I.A. innovator of the 'spot' or 'distant vision' method of obtaining RI readings from cabochon stones, has become 'Lester Brown'. Lechleitner's name is misspelt throughout. Paste is called 'Stross, after the Austrian Joseph Stross'. All other references we can find call it 'strass' after Josef Strasser. The last three could have been printer's errors for, unfortunately, there are many of these. Mostly minor, they are nevertheless irritating and could have been eliminated by careful proof-reading. One accepts differences between American and English spelling, but these do not extend to 'pehnomemon', 'carbochon', 'oobjects', 'larg', 'rutile', 'aquarmarine', 'celluoid', or 'flourite', to list but a few.

To summarize, this may be a better American book than those which have been published before, but we cannot agree that it is necessarily better gemmologically than the Coles Phillips revision of G. F. Herbert Smith's 'Gemstones', not to mention other works which are recommended by the present authors as 'Suggested Reading' at the end of some of their chapters. They are obviously very much at home in the profound depths of mineralogy, but have occasionally foundered in the comparative shallows of gemmology; largely because our simpler techniques are, for quite good reasons, less familiar to the parent science. In its present form 'Gemology' could be considerably improved by careful reading and correction. We feel, also, that the publishers and proof readers have not done justice to their authors.

R.K.M./B.W.A.

KING (E. A.). *Texas gemstones*. Bureau of Economic Geology, University of Texas, Austin, Texas, 1972. pp.42. Illus. in black-and-white. Price on application. (Bureau of Economic Geology, Report of Investigations, 6.)

Minerals with a definite or possible gem application are listed alphabetically in this short guide. They include amber, beryl, garnet, fluorite, one authenticated find of diamond, turquoise and varieties of quartz.

M.O'D.

LAGACHE (H.). *Initiation à la gemmologie*. (Initiation in gemmology.) Institut National de Gemmologie, Paris, 1979. pp.88, xxvi. F110.

This is a small-sized, simple introduction to gemmology designed for students, who will find it convenient and undemanding. Diagrams of basic phenomena are illustrated by sketches, for the most part accurate (though the zircon crystal seems to have slipped somewhat) and the accompanying text is free from wordiness. Those wanting details of stones will need to look elsewhere, since this book deals only with the process of testing; it succeeds admirably in its limited purpose. M.O'D.

LEAMING (S. F.). *Jade in Canada*. Geological Survey of Canada (Paper 78-19), Ottawa, 1978. pp.59. Illus. in black-and-white. \$8.00 (\$4.00 in Canada.)

So far as is known at present only nephrite of the two jade minerals occurs in Canada. Known deposits are described and mapped with some of the material being chemically analysed. Production and geological details are given, with references. Some foreign nephrite is also analysed. M.O'D.

MARFUNIN (A. S.). *Spectroscopy, luminescence and radiation centers in minerals*. Springer, Berlin, 1979. pp.xii, 352. \$(US)59.40.

Translated from the Russian, this is a major study of the subjects in its title. Of particular interest to those studying the scientific aspects of gem materials will be the long chapter on luminescence in which basic concepts are explained and a history of developments given. Present-day tests are described and in earlier parts of the book the importance of crystal field theory is well explained. A section describing colour centres in minerals also includes crystal diagrams depicting how the holes arise and lists minerals in which they are important. There is an index and a good bibliography. M.O'D.

MILLER (C. E.), HERMES (O. D.). *Minerals of Rhode Island*. University of Rhode Island, Kingston, Rhode Island, 1972. pp.83. 24 illus. \$2.00.

This book is the successor to *Rhode Island minerals and their locations* published in 1971. It is arranged in alphabetical order of mineral names; there are maps and a bibliography. Ornamental species found in the State include titanite, amethyst, the chistolite variety of andalusite, calcite and bowenite. M.O'D.

MITCHELL (R. S.). *Mineral names—what do they mean?* Van Nostrand Reinhold, New York, 1979. pp.xv, 229. £10.45.

A most useful book in which introductory chapters list mineral names by type (i.e. from persons, places, chemical composition, classical languages) and the rest of the book is devoted to a complete alphabetical list in which I could find no significant errors or omissions (vorobyevite, a name sometimes given to a variety of beryl, was not there). Especially useful is an overall index and a list of names for which no history could be found. M.O'D.

ROOT (F. K.). *Minerals and rocks of Wyoming*. Wyoming Geological Survey (Bulletin 56), Laramie, 1977. pp.84. Illus. in black-and-white and in colour. \$3.00.

Wyoming is celebrated for its nephrite and for several varieties of agate, of which Sweetwater agate is probably the best known. This small guide illustrates a

number of minerals and gives directions to important sites, several of which are shown on maps. Introductory chapters discuss the geology of the State. M.O'D.

SCHMELTZER (H.). *Mineral-Fundstellen-Bayern*. (Mineral localities—Bavaria.) Weise, Munich, 1977. Illus. in black-and-white and in colour. pp.227. DM32.

This completes the excellent series of guides to mineral sites in Europe; at least no more are currently advertised. Bavaria contains some important sites, including the pegmatite at Hagendorf and the rose quartz deposit at Kreuzberg near Pleystein. Some attractive green beryl is found at Hühnerkobel near Rabenstein. As usual the book has first-class references and locality maps. M.O'D.

TRÖGER (W. E.). *Optical determination of rock-forming minerals*. Schweizerbart'sche Verlagsbuchhandlung, Stuttgart, 1979. pp.188. DM48.

This is the English version of the book reviewed in the *Journal*, XV, 6, 337, 1977. M.O'D.

WILKE (H.-J.). *Mineral-Fundstellen. Vol. 7. Hessen*. (Mineral locations—Vol. 3—Hesse.) Christian Weise Verlag, Munich, 1979. Illus. in black-and-white and in colour. pp.240. DM36.

This is the latest addition to the well-known and justly celebrated series of guides to European mineral locations. The sites are each exhaustively documented, all the major ones having maps and some have especially fine minerals illustrated in colour. A first-class bibliography is included. The area, in which Frankfurt is roughly central, includes such well-known sites as Aschaffenburg where spessartine and beryl are found; fine micromount material includes titanite, cerussite and apatite. M.O'D.

WILSON (W. F.), MCKENZIE (B. J.). *Mineral collecting sites in North Carolina*. (Information circular 24), North Carolina Department of Natural Resources and Community Development, Geological Survey Section, Raleigh, N.C., 1978. pp.vii, 122. Illus. in colour. Price on application.

This attractive work includes the plates from Kunz's *The history of the gems found in North Carolina*, published in 1907 and now a rare work. Other plates show the range of gem material found in the State; maps cover all the major areas and the constituent minerals are well described with brief detail and historical notes. M.O'D.

Diamond digest. Diamond Selection Ltd, London EC1. Annual subscription £10.00.

This journal began as telexed notes on diamond prices but is now enlarged to include a variety of market reports, abstracts and editorial comment. Very valuable for those with a commercial interest in diamond. M.O'D.

Les gemmes et leur identité. (Identification of gems.) Association Française de Gemmologie, Paris, 1978. Price on application.

This book consists of a number of cards in a ring binder, each card dealing with a particular gemstone and giving its constants, characteristic inclusions, common simulants where applicable and stones with which it may be confused. Not all cards are currently included since there are still some to be published; these include some simulants. The cards are also issued with the *Revue de Gemmologie*, the official organ of the Association. M.O'D.

ASSOCIATION NOTICES

GIFTS TO THE ASSOCIATION

The Council of the Association is indebted to the following for their gifts:

Dr N. R. Barot, F.G.A., Nairobi, Kenya, for a collection of six pieces of rough and seven cut specimens of golden brown garnets (Umba River, Tanzania), green grossular garnets (Lualenyi Voi, Kenya) of different shades of colour and a purple scapolite (Tanzania).

Mr R. Holt, F.G.A., London, for a copy of the book 'The Jewelled Trail', by Louis Kornitzer.

Mr Milton R. K. Lu, of the China Gemmological Association, Taiwan, for a round cubic zirconia of 2.11 ct, with a special cut of 144 facets.

Mr E. A. Thomson, London, for a small round green andradite cut stone of 0.16 ct from Korea, a white round herderite of 0.15 ct from Brazil, and an oblong step-cut, transparent, very pale brown, 0.96 ct specimen of diaspore.

Mr Mai van Lieu, F.G.A., Brussels, Belgium, for a book entitled 'Ivoires de Chine' by Mai van Lieu and Pierre-Jean Schaeffer.

NEWS OF FELLOWS

Mr M. J. O'Donoghue, M.A., F.G.S., F.G.A., attended the third 'Convegno' of the Italian Gemmological Institute in Milan on the 18th November, 1979, and read an illustrated paper on 'New Developments in Man-Made Materials'. Mr O'Donoghue has also taken over the editorship of *Gems*, the bi-monthly mineral, gem and lapidary magazine now in its 12th volume.

On 7th December, 1979, Mr P.G. Read, C.Eng., F.G.A., gave a talk on 'Gem and Industrial Diamonds' to the Bournemouth and Poole Medical Society (the President is Dr W. Cross, F.G.A.). Also, Mr Read will be organizing a Gemmology Weekend Course in Chichester, from 30th May to 1st June, 1980.

OBITUARY

Mr Charles R. Miller, F.G.A. (D.1975), Southfield, Michigan, U.S.A., died on 3rd September, 1979.

Mr Dennis R. Selvon, F.G.A. (D.1962), Woodford Green, Essex, died on 27th December, 1979.

Mrs Joyce M. Thomas-Ferrand, F.G.A. (D.1950), Bury St Edmunds, Suffolk, died on 8th January, 1980.

MEMBERS' MEETINGS

Midlands Branch

On 29th November, 1979, at the Central Hall, Corporation Street, Birmingham, a 'Mastermind Quiz' on gemmology was held, with Mr S. Tisdall, F.G.A., as Quizmaster.

On 25th January, 1980, at the Society of Friends, Dr Johnson's House, Colmore Circus, Birmingham, Mr J. G. Todd, F.G.A., of Lotus Pearls, gave an illustrated talk on 'Real and Cultured Pearls'.

On 22nd February, 1980, also at the Society of Friends, Mr M.J. O'Donoghue, M.A., F.G.S., F.G.A., gave an illustrated talk on 'Gem Locations'.

North-West Branch

On 29th November, 1979, at Church House, Hanover Street, Liverpool, a 'practical evening' was held, when specimens and instruments were available to members for examination and discussion.

On 10th January, 1980, at Church House, Mr John L. Pyke, F.G.A., gave an illustrated talk on 'Mining Operations in Colombia and Thailand'. Members were also able to examine his personal collection of gemstones.

On 7th February, 1980, at Church House, a demonstration of simple silver-smithing was given by Mr Jim Hunter.

South Yorkshire Branch

On 6th March, 1980, at the Sheffield City Polytechnic the Annual General Meeting of the Branch was held. Dr M. W. Eldridge, M.B., Ch.B., F.G.A., was re-elected Chairman and Miss J. I. Platts, F.G.A., elected Secretary.

ANNUAL REUNION OF MEMBERS AND PRESENTATION OF AWARDS

The Annual Reunion of Members was held at Goldsmiths' Hall during the evening of Monday, 19th November, 1979, when a large number of members attended.

The Reunion was followed by the Presentation of Awards and the Chairman, Mr Douglas King, welcomed members and the large number of recipients with their relatives and friends who were present that evening, mentioning that people from twelve countries apart from England had come to receive their awards in person, some of them coming from places far afield. He continued that it was always pleasant to welcome the recipients of awards and it was an added pleasure that the results this year were a little better than in recent years. Yet again a record was set for the numbers taking the Examinations: for this Gem Diamond Examination 55 candidates sat, for the Diploma 491, and for the Preliminary 748, of whom 42 passed in the Gem Diamond Examination (including two distinctions), 198 passed in the Diploma (including 10 distinctions), and 363 passed in the Preliminary. Unfortunately the Examiners had been unable to recommend the award of the Tully Medal or the Rayner Prizes, but Dr Roger Harding was congratulated on submitting the best set of papers in the Diploma Examination. The Examinations were as usual held in many countries overseas and thanks were due to all those persons and



Mr B. W. Anderson and Mrs Ameena Kaleel (Sri Lanka).



Left to right: Mr A. E. Farn, Mrs Zwaan, Professor Dr Pieter Zwaan and Professor Dr M. Font-Altaba.

organizations that gave assistance to make this possible. He referred in addition to the large amount of work done by the Association's Headquarters staff and thanked all concerned for this.

The Chairman then introduced and welcomed Professor Dr Pieter Zwaan, F.G.A., Acting Director of the National Museum of Geology and Mineralogy at Leiden, Netherlands, and called upon him to present the awards.

When the presentations had been made, Dr Zwaan delivered a short address, which is recorded in full below.

After Dr Zwann had concluded his address, the Vice-Chairman, Mr David Callaghan, expressed the thanks of the assembled company to Dr Zwaan, and the Chairman after thanking the Worshipful Company of Goldsmiths for again allowing the use of their fine Hall, then declared the meeting closed.

PROFESSOR DR PIETER ZWAAN'S ADDRESS

Ladies and gentlemen, this day is an important day in your life, because you are considered to be gemmologists from now on and what that means cannot be said in a few words.

Gemmology developed enormously during the last twenty years. This was apparently due to the large amount of new stones, both natural and synthetic, that came on the market. For that reason there is a great difference between the contents of the questions at the examinations I passed myself exactly 25 years ago, and those of this year. Since 1954 new techniques have been developed and new methods have been introduced. Gemmology became more and more independent of mineralogy, due to its own ways of investigation. But, originating from a geological school in which mineralogy played an important part, I still consider gemmology as a very special field in mineralogy. In fact, this is not important: what is of importance is the rapid development of this part of science.

Returning to 1954, the only synthetic emerald known was the one manufactured by Carroll F. Chatham. Stones like blue zoisite and emerald-green grossular garnet were not yet discovered. The rare earth synthetic garnets, if I may use the word like a crystallographer, were not yet produced. At that time only corundums made by the flame-fusion method occurred, together with spinel. Turning over the leaves of a gemmological journal of 1954, papers can be seen on immersion contrast, on taaffeite and sinhalite and, of course, on inclusions in gemstones. Nomenclature problems also existed, as with jade. A new type of heat-treated amethyst, called prasiolite, was mentioned for the first time. But believe me, ladies and gentlemen, gemmologists had difficulties, as we have them now—problems which could hardly be solved.

Coming to 1979, it is needless to tell people who have just passed their examinations how many new problems have appeared in gemmology. In my opinion, in the nearest future, the most important matter will be to find out whether the colour of a gemstone has been changed or not. There are several ways of treatment, amongst which irradiation is very popular nowadays and very effective. In this respect I should like to draw your attention to the most useful work done by one of the greatest gemmologists of this century, Basil W. Anderson. His contribution to absorption spectroscopy has been of great importance in gemmology. He discovered anomalies in the absorption spectra of treated diamonds. He also gave indications how to continue in this special field of gemmology. I am certain that new efforts in absorption spectroscopy will give highly important results as far as the origin of the colour of a gemstone is concerned.

From what I have said up to now it will be clear that you are at the beginning, not at the end. I feel privileged to congratulate you with your success and I want to ask you to be active in this beautiful part of science. I hope with all my heart that you did not take classes in gemmology merely in order to obtain a diploma, but with a firm intention to contribute to this very special science which we all love!

ANNUAL GENERAL MEETING

The Association's Annual General Meeting will be held at Saint Dunstan's House, Carey Lane, London EC2V 8AB on Friday, 16th May, 1980, at 6 p.m.

SPINEL REFRACTOMETERS

The Association would be interested in acquiring one or two spinel refractometers from members who no longer require them. Members are requested to write with details of condition and suggested price to the G.A. office.

CROSSED FILTERS TECHNIQUE

To use the crossed-filters technique with a spectroscope it is usually recommended that a high intensity light source be directed through a flask containing a saturated copper sulphate solution. Some spectroscope units are so constructed that this is not possible, and it is difficult to obtain a thin filter suitable for this purpose.

One member has solved the problem by growing a copper sulphate crystal and sawing this into slab form. The slab was large enough to cover the iris diaphragm area of the instrument, and the top and bottom were lapped flat. This was done by rubbing dry with 400 grit silicon carbide on a glass plate. The resulting filter was 2.5 mm thick.

LETTER TO THE EDITOR

From Mr R. Keith Mitchell, F.G.A.

Dear Sir,

Alas poor Ångström!

The Ångström unit is expected 'to fall into disuse'. It is obsolescent, which means the same thing—not that it is already obsolete! It is being replaced in light wave measurements by a new unit called the nanometre in the general metrification imposed by the system known as SI.¹ The relationship between the two measurement units is a simple one since 10 Ångströms equal 1 nanometre. So the Ångström is no less a metric unit than is its replacement.

So, it would seem that this memorial to a great Swedish physicist is to be sacrificed on the altar of change for the sake of change.

Ander Jonas Ångström was born in 1814, the year in which J. Fraunhofer discovered the famous 'lines' in the sun's spectrum, and made the first crude diffraction grating by stretching wire between threads of two screws. Ångström was a founder of spectroscopy and was the man who first discovered hydrogen in the atmosphere of the sun in 1862, introducing the Ångström Unit as a convenient measure of the minute wavelengths involved. In 1868 he published a map of the sun's normal spectrum which remained authoritative for many years. He held the Chair in Physics at Uppsala University from 1858 until his death in 1874. Such a man should continue to be commemorated.

After all, who was Nano? No one, the word is Greek for dwarf or something very small.

1. See J. Gemm., 1977, XV (5), 243.—Ed.

Not to be outdone, certain gemmological writers have started using another physicist's unit and are referring to light wavelengths in terms of frequency or of wavenumber, i.e. the number of waves per centimetre. This is, in effect, the reciprocal of the normal wavelength measurement, so that $16\,000\text{ cm}^{-1}$ is equivalent to 6250 \AA . This is not new. Fraunhofer, too, measured his wavelengths in centimetres.

The SI is keeping the Newton, the Ohm, the Coulomb and has brought back dear old Hertz, so why ditch poor Ångström? Will no one start a movement to 'Keep Ångström's Unit bright!?' If not, then at least let us stick to the nanometre and not introduce yet another method of measurement without good reason.

Yours etc.,
R. KEITH MITCHELL.

30th August, 1979. Orpington, Kent.

CORRIGENDUM

By an unfortunate printer's error on p.2 above only part of Figure 1a (in S. Borg's 'An Unusual Star Peridot') was reproduced, and the full Figure 1a is accordingly printed below.

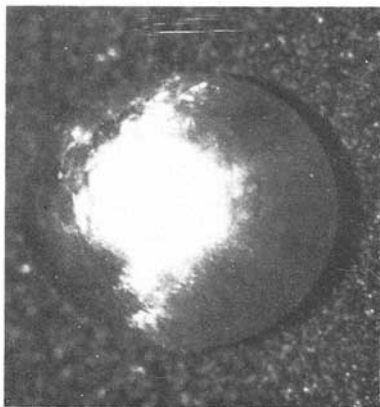

FIG. 1a. Star peridot showing sheen and star under single strong light source.

Historical Note

The Gemmological Association of Great Britain was originally founded in 1908 as the Education Committee of the National Association of Goldsmiths and reconstituted in 1931 as the Gemmological Association. Its name was extended to Gemmological Association of Great Britain in 1938, and finally in 1944 it was incorporated in that name under the Companies Acts as a company limited by guarantee (registered in England, no. 433063).

Affiliated Associations are the Gemmological Association of Australia, the Canadian Gemmological Association and the Rhodesian Gem and Mineral Society.

The *Journal of Gemmology* was first published by the Association in 1947. It is a quarterly, published in January, April, July, and October each year, and is issued free to Fellows and Members of the Association. Opinions expressed by authors are not necessarily endorsed by the Association.

Notes for Contributors

The Editor is glad to consider original articles shedding new light on subjects of gemmological interest for publication in the *Journal*. Articles are not normally accepted which have already been published elsewhere in English, and an article is accepted only on the understanding that (1) full information as to any previous publication (whether in English or another language) has been given, (2) it is not under consideration for publication elsewhere and (3) it will not be published elsewhere without the consent of the Editor.

Articles published are paid for, and any number of prints of individual articles may be supplied to authors provided application is made on or before approval of proofs. Current rates of payment for articles and terms for supply of prints may be obtained on application to the Secretary of the Association.

Although not a mandatory requirement, it is most helpful if articles are typed (together with a carbon copy) in double spacing on one side of the paper, with good margins at sides, top and foot of each page. Articles may be of any length, but it should be borne in mind that long articles are more difficult to fit in than short ones: in practice, an article of much more than 10 000 words (unless capable of division into parts or of exceptional importance) is unlikely to be acceptable, while a short note of 400 or 500 words may achieve early publication.

Vol. XVII
No. 2
April, 1980

C O N T E N T S

Notes from the Laboratory	<i>A. E. Farn</i>	p.69
An Opal Imitation made from Latex ..	<i>M. J. O'Donoghue</i>	p.80
Two Reports:		
(1) Alternative Refractometer Light Sources:		
(2) Thermal Diamond Probes	<i>P. G. Read</i>	p.82
The Gemmiferous Gravels of the Fraser and Reddistone Creeks, Inverell-Glen Innes District, New South Wales	<i>P. L. Broughton</i>	p.95
Gemmological Abstracts		p.119
Book Reviews		p.132
ASSOCIATION NOTICES		p.138

Copyright © 1980
Gemmological Association of Great Britain
Registered Office: Saint Dunstan's House, Carey Lane, London EC2V 8AB