

Gems & Gemology

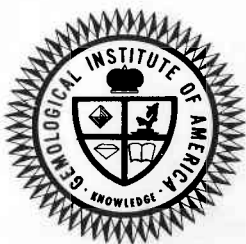

SPRING 1974



RICHARD T. LIDDICOAT, JR.

Editor

ROBERT A. P. GAAL, Ph.D.

Assoc. Editor

GEMS & GEMOLOGY is the quarterly journal of the Gemological Institute of America, an educational institution originated by jewelers for jewelers. In harmony with its position of maintaining an unbiased and uninfluenced position in the jewelry trade, no advertising is accepted. Any opinions expressed in signed articles are understood to be the views of the authors and not of the publishers. Subscription price \$3.50 each four issues. Copyright 1973 by Gemological Institute of America, 11940 San Vicente Boulevard, Los Angeles, California 90049, U.S.A.

GEMS & GEMOLOGY

gems & **g**emology

VOLUME XIV

NUMBER 9

SPRING 1974

IN THIS ISSUE

- 258 ... **The Why of This Issue**
- 259 ... **The Measurement of Brilliance of Diamonds**
By Dr. Werner E. Degenhard
- 271 ... **Material in Rebuttal to Degenhard Report**
- 273 ... **The Optical Quality of Two Different Brilliant Cut
Diamonds – A Comparative Investigation**
By Dr. Werner R. Eulitz
- 284 ... **World Diamond Production – 1973**
- 285 ... **Book Reviews**
- 287 ... **In Memoriam**

The Why of This Issue

In order to settle certain litigation between Huisman Bros., Inc., Gemological Institute of America, Lazare Kaplan & Sons, Inc., Leo Kaplan and George R. Kaplan, the parties have agreed that Gemological Institute of America would publish in *Gems & Gemology* the following:

1. Report of Dr. Werner E. Degenhard wherein he claims that the Huisman 144-facet cut diamond is 32% more brilliant than the 58-facet cut diamond.
2. The rebuttal by Gemological Institute of America of the Degenhard report and the Huisman Bros., Inc., claim, and,
3. The report of Dr. Werner E. Eulitz wherein he rebuts the findings of Dr. Werner E. Degenhard and concludes that the 144-facet cut is actually less brilliant than the 58-facet cut diamond.

The Measurement of Brilliance of Diamonds

Werner E. Degenhard*
Carl Zeiss, Inc. — New York

SUMMARY: Two differently cut diamond types were measured with a goniophotometer to establish the apparent visual difference in figures.

The 58-facet diamond and the patented 144-facet diamond cut by Huisman Brothers exhibit distinct differences in the reflection pattern.

The 144-facet diamonds have more reflections under normal viewing conditions than the 58-facet diamonds. The mean value of the obtained data shows that the brilliance of the 144-facet diamonds under investigation was 32% higher.

1. The problem.

It is to be established that the apparent visual difference in two different types of "brilliant" cut diamonds can be substantiated by instrumental readings. The diamonds in question are a 58-facet diamond and a patented 144-facet diamond cut by Huisman Brothers.

The comparison was accomplished by goniophotometric measurements on pairs of diamonds which were selected to match in diameter, total height, top height and angles between top and bottom. The remaining uncertainty was the in-

accuracy of the facet angles.

The first investigations had started in 1969 at Carl Zeiss London, England. They were continued for a period of more than one year at Carl Zeiss, Inc., New York and have resulted in the following report.

2. Definition of technical terms. (see Figures 1 and 2)

Refraction: The speed of light is reduced if a light beam enters a medium with a higher refractive index. If the beam enters under an angle lower than the critical angle, it is totally reflected. If the incident angle is larger than the critical angle, the beam is refracted toward the normal. If the beam leaves the medium with a higher refractive index, it is refracted away from the normal and gains its original speed (see Figure 1).

Reflection: All beams impinging a surface at angles lower than the critical angle are totally reflected. This, of course, is also true for reflections within the medium with higher refractive index (see Figure 1).

Critical angle: The angle between the vertical (normal) to a surface and a light beam which is just not re-

*For author's credit, see page 270.
SPRING 1974

flected anymore but enters the second medium. The critical angle varies considerably with the refractive indices of the two media involved (*see Figure 1*).

Aperture: a) The opening of an optical system such as the iris diaphragm in a photographic camera. b) The illuminating or observing angle of a surface element. The angle between the lines drawn from the aperture of the optics to the surface element (*see Figure 2*).

3. Definition of brilliance.

Brilliance is an optical sensation which has not been clearly defined. It seems that a high refractive index of the sample and a considerable number of reflections with some intensity on small not identifiable facets produce the effect of brilliance. The intensity of the reflections should not be too small, because then they are not considered "brilliant". On the other hand, the intensity should not be too high so that the eye is more or less blinded by the single sparks. The number of the reflections must be such that the eye is able to resolve the reflections, otherwise the sensation is only "brightness". Many reflections of medium intensity are perceived more brilliant than a few reflections with high intensity, equal dimensions of the sample provided.

All measurements and the consequences drawn thereof are made under the above described assumptions. The measuring conditions were selected under the consideration that they should come as close as possible to the "normal" observation of bril-

liance by the human eye.

4. Differences between visual observation and measurement.

A photoelectric detector resembles the human eye only to some degree. The response (conversion of light into current) of a photoelectric detector is linear with the impinging light in the normal brightness range. The human eye does not respond linearly. It cannot separate differences of intensity which vary by the factor of 2 within the intensity range in question. This means that intensities recorded with 10 or 20 scale divisions of the measuring device are seen with the same intensity.

The human eye is able to see many reflections simultaneously and record in the brain the location of origin of each single reflection. The eye sees a pattern. In this respect it works similar to a photographic camera. The photoelectric detector, however, records only the sum of all reflections and cannot locate the origin of the individual reflection or the pattern. A measuring instrument, which is supposed to substantiate the visual perception in figures, can do this only sequentially.

5. The instrumentation.

The Zeiss Goniophotometer GP-2 was considered suitable to fulfill the above described requirements (*see Figure 7*). The instrument permits to vary the angle of illumination and observation between 0 and 75 degrees. The apertures (*see paragraph 2*) can be varied between 2 and 0.25 degrees. For this particular problem the aperture of illumination was

reduced to 0.1 degree to increase the resolving power. The illuminator opening was reduced to 8 mm to prevent stray light from entering the detector. It is understood that the samples were completely illuminated. Since the simultaneous observation of all reflections is not suitable (see paragraph 4), the samples were mounted on a rotating holder which rotated continuously. After each revolution, the observation angle was changed one half of a degree. The measuring values were recorded continuously on a strip chart recorder, the sensitivity of which was adapted to the brightness level.

But it should be emphasized that for the quantitative evaluation the measuring parameters remained constant. The experimental set-up is described in paragraph 8.

6. Qualitative results.

Since diamonds are cut manually and the measuring tools do not allow for high accuracy, the reflections of diamonds of the same type vary even under identical measuring conditions. After investigating approximately 50 pairs of diamonds of various diameters, it was found that diamonds reflect in "zones" (see Figure 3). The pattern varies to some degree, but in general it depends on the number of facets.

Figures 4 and 5 represent the typical patterns which were found to a higher or lesser degree in all pairs compared. More reflections of medium intensity are found closer to the table in the 144-facet diamond whereas the 58-facet diamond shows zones of medium and higher inten-

sities further out. The fact that the 144-facet diamond concentrates the light toward the table will become understandable if the cross sections of the diamonds are examined. Figure 6 illustrates this in simplification. The cross section of a 58-facet diamond resembles a triangle, whereas the cross section of the 144-facet diamond approaches the form of a hemisphere. If parallel light shines into a cone, the light is collected into a "focal line". The hemisphere collects it into a point. The focal line of a 58-facet diamond is vertical that means the light is diverted from the table downward. According to this conclusion, it could be expected that at observation angles from 0 to 10 degrees more reflections should exist in the 144-facet diamond; in other words, more brilliance should occur.

7. Quantitative results.

The normal examination of the diamond is made by looking at it vertically to the table. It may be rotated to some degree and also slightly tilted. According to expert information, the tilting angle is never more than 10 degrees. The source for the illumination is under normal conditions the sky or an artificial light source such as a fluorescent lamp. In any case, the source is extended and the illuminating angle cannot be defined precisely. The value may lie between 15 and 45 degrees to the table.

As a compromise, an illuminating angle of 27 degrees was considered as justified. The observation was recorded between 0 and 12.5 degrees to the table which should include all

variations of visual observation. As mentioned, the aperture of the detector was set at 0.1 degrees to assure that all reflections were resolved. In order to maintain the highest resolving power possible, the observation angle was varied in steps of 0.5 degrees.

The notations in the following *Table 1* represent the number of deflections of the recorder pen larger than 5 scale divisions. As a reminder, it may be stated that the scale divisions do not represent the sensation of the human eye quantitatively. It can be considered correct that recorder deflections between 5 and 20 scale divisions are perceived with equal or near equal intensity.

The readings were divided into three zones to demonstrate again the qualitative findings.

In *Table 2* the differences of the added numbers are noted. Since the human eye sees all zones simultaneously, it is correct to form the mean values for all zones. The final result is that the diamond with 144 facets has more brilliance than the diamond with 58 facets. The average figure for the samples under examination was 32.2%.

8. Experimental set-up

The recordings were made with the Zeiss Goniophotometer GP-2 and an attached recorder with sensitivity ranges from 2 to 200 mV (Servogor recorder). The diamonds were glued into a special holder which rotated around its vertical axis at approximately one revolution per minute.

The schematic arrangement is shown in *Figure 8*. The diamonds were so adjusted that the girdles were in the

sample plane of the instrument. The tables protruded into the instrument. In some qualitative recordings the tables were brought in the sample plane. This changed the amplitude to some degree but not the significant pattern of the diamond type. The specular reflectance was avoided by tilting the diamond slightly to the back from the vertical axis.

For some recordings (I to XIV) the aperture of the illumination was increased to 7 degrees by removing the aperture holder. For quantitative measurements, however, the aperture was reduced to 0.1 degree by taping. The sensitivity of the recorder had to be adjusted accordingly. Again, all quantitative recordings were made with identical parameters.

The sample opening was closed by a blackened sheet with a hole of 10 mm in the center through which the diamond was illuminated. This was found useful to prevent background on the recordings. The base line of the recordings was set in coincidence with the printed zero-line by shifting the zero adjustment.

The diamond carrier was marked and an index permitted to define a single revolution. The diamond rotated continuously. Any time the mark passed the index, the observation angle was changed one or one half of a degree. The recording speed was 10 mm/min for the qualitative recordings and 40 mm/min for the quantitative recordings.

D. E. Dyer

February 26, 1971

TABLE 1

A. Diamond with 58 facets

Diameter	0 - 5°	5 - 10°	10 - 12,5°
6,8	54	73	30
6,8 reset	75	72	-
6,8	90	72	46
6,8 reset	84	88	54
6,6	81	75	39
6,6 reset	72	68	29
5,3	104	95	32
5,1	60	64	40
5,0	94	98	34
4,9	71	62	21
4,9 reset	84	102	31
4,175	33	34	21
Total:	712	773	377

B. Diamond with 144 facets

Diameter	0 - 5°	5 - 10°	10 - 12,5°
6,7	74	116	51
6,7 reset	77	110	-
6,8	95	101	44
6,8 reset	92	106	45
6,6	93	119	37
6,6 reset	100	107	47
5,3	95	104	45
5,0	98	96	39
4,9	96	71	32
4,6	53	62	37
4,6 reset	76	79	69
4,2	47	39	31
Total:	899	1110	477

TABLE 2

Evaluation of TABLE 1

	0 - 5°	5 - 10°	10 - 12,5°
Differences	187	337	100
Gain	+ 26,2	+ 43,5	+ 26,9

Average gain: 32,2 %

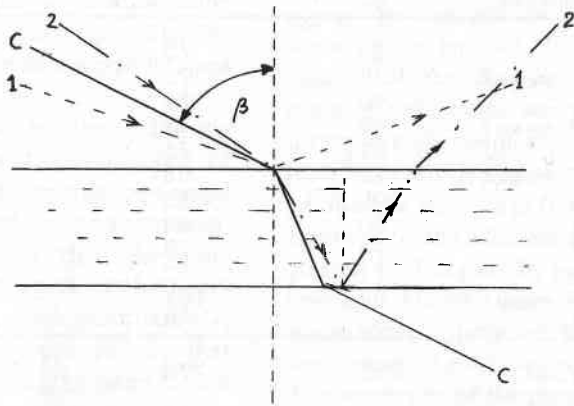

FIGURE 1

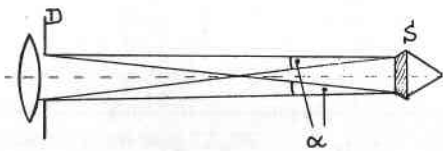

FIGURE 2

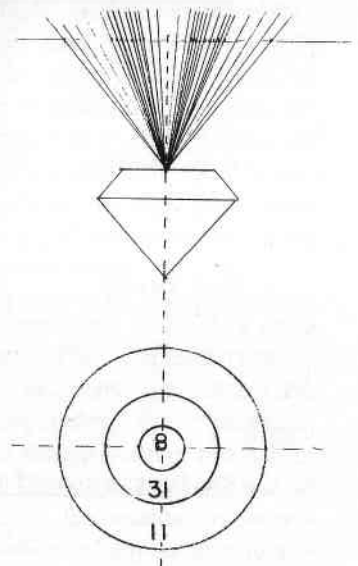

FIGURE 3

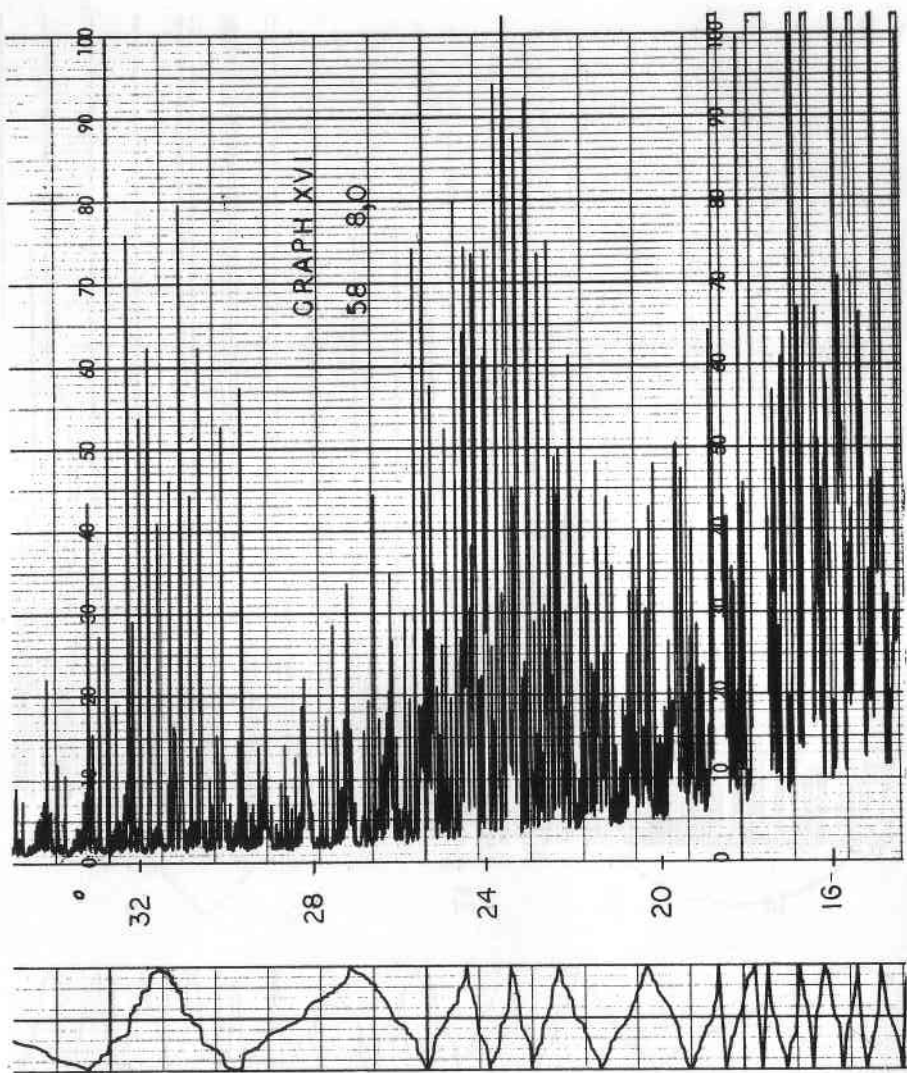

FIGURE 4

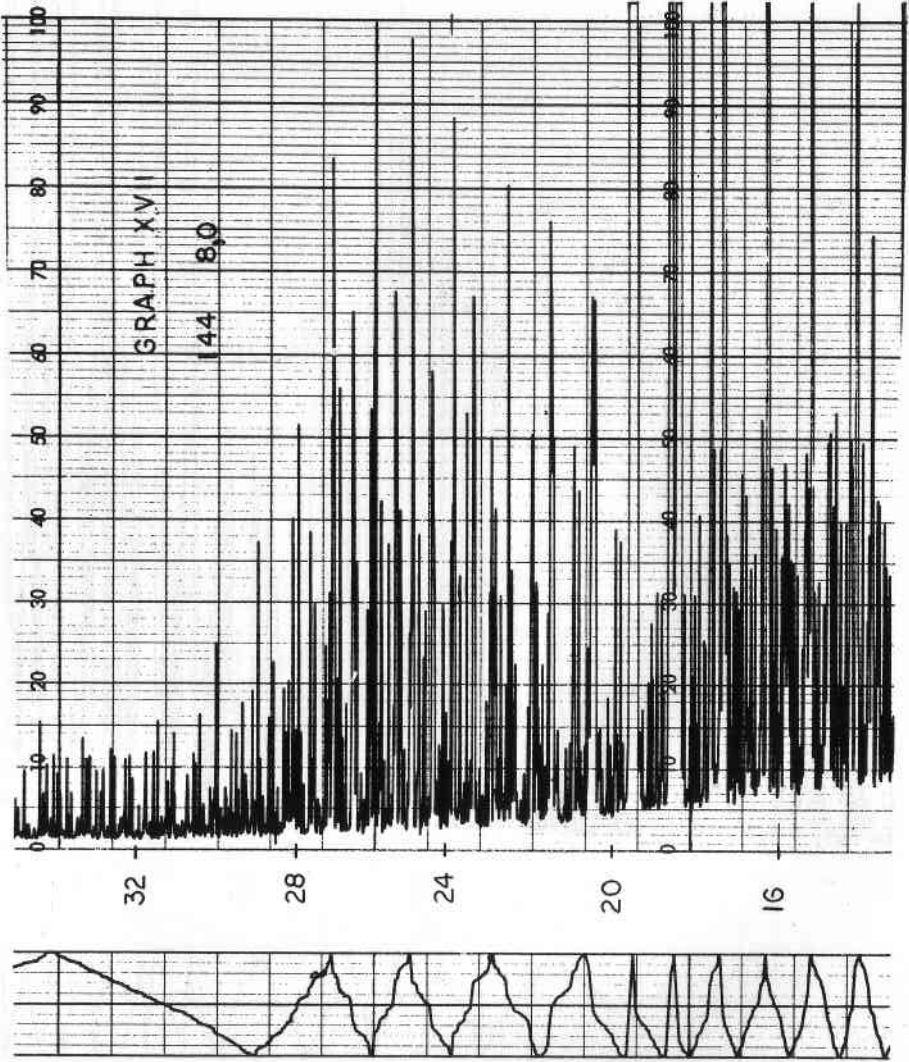

FIGURE 5

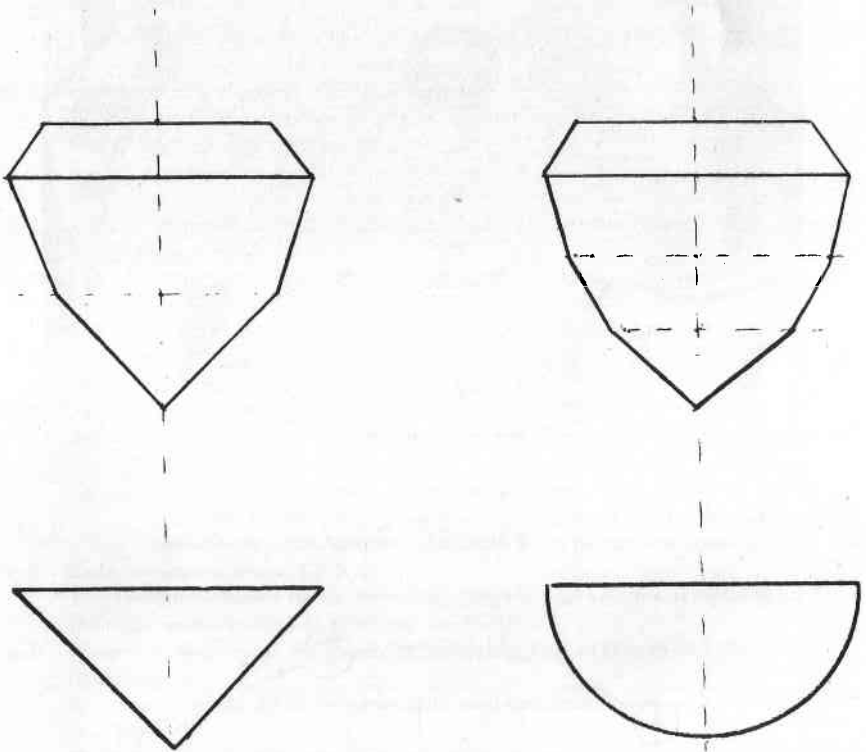

FIGURE 6

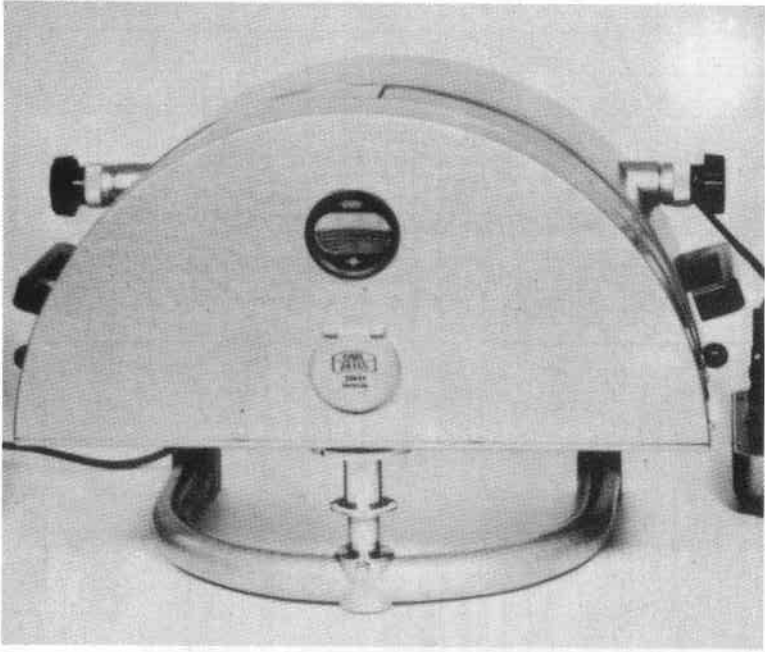

FIGURE 7

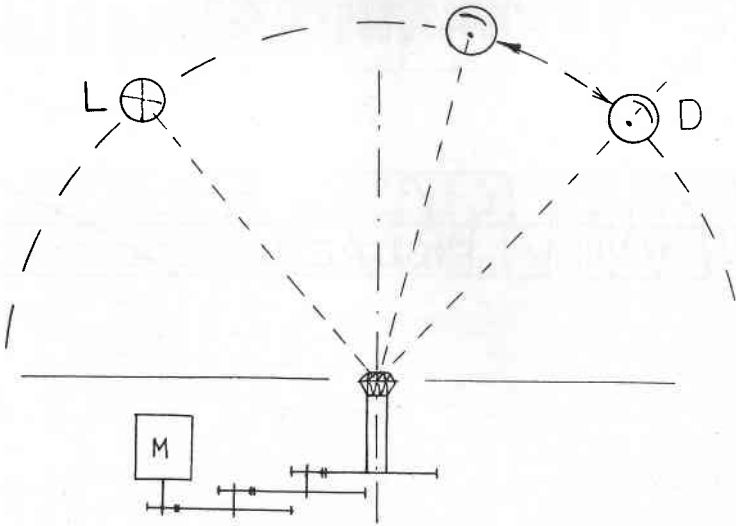

FIGURE 8

LEGENDS:

- Fig. 1. Refraction, reflection and critical angle.
Beam 1 below critical angle — totally reflected.
C — beam which impinges under critical angle.
Beam 2 above critical angle enters medium.
 β = critical angle.
- Fig. 2. Aperture.
The beams emerging from the diaphragm D hit each surface element under the angle α . Only the outer beams are drawn.
- Fig. 3. Reflection of a diamond in zones.
The number and intensities of the reflections vary periodically. The lower figure demonstrates schematically the obtained figures of a measurement: the inner zone emits 8 reflections, the second zone 31 and the third zone 11 reflections.
- Fig. 4. Typical reflection pattern of a 58-facet diamond. The illumination angle was 15° , the aperture 7° .
- Fig. 5. Typical reflection pattern of a 144-facet diamond. The illumination angle was 15° , the aperture 7° . If compared with Fig. 4, it will be noticed that the first emission zone is closer to the incident beam, the second zone does not appear within the recorded angles. The light is more concentrated toward the center of the diamond.
- Fig. 6. Explanation for the different reflection pattern.
Above: Schematic cross-section through a 58-facet diamond (left) and a 144-facet diamond (right).
Below: Extreme simplification of the two diamond types. The cone (left) produces a focal line if illuminated with parallel light, whereas the hemisphere (right) concentrates parallel beams into one point.
- Fig. 7. Zeiss Goniophotometer GP-2
The horseshoe-shaped stand carries the sample holder which was replaced by the rotating shaft which in turn held the diamond.
- Fig. 8. Schematic diagram of the measuring assembly used to determine reflections of diamonds.
L — Light source. 30 W Tungsten bulb with projection optics and a variable aperture.
D — Detector. A selenium photocell with projection optics and variable aperture. The cell was directly connected with a multi-range recorder.
M — Clock motor with gear. The duration of one rotation was approximately one minute.

EDITOR'S NOTE

Dr. Werner E. Degenhard was born in Germany in 1914. He studied chemistry and engineering and received his PhD degree in chemistry and engineering from the University of Berlin. During World War II he was involved in the teaching of high frequency electronics and radar in a supervisory capacity.

In 1949 Dr. Degenhard became assistant professor at the University of Darmstadt, Germany, in the Department of Chemistry. In 1951 he joined Carl Zeiss as a staff member of the Electron Microscope Department, and in 1957 he joined the staff of the

Analytic Instrument Department of Carl Zeiss. In 1960 he became the Supervisor of Customer Laboratories at Carl Zeiss.

In 1962 Dr. Degenhard became Scientific Director of Carl Zeiss, Inc., New York. In addition, he became the consultant for planetarium installations in the U.S. and Canada. Dr. Degenhard also was the science advisor regarding all equipment in microscopy and the introduction of new instrumentation. In 1971 he rejoined Carl Zeiss Germany as Chief of Instrumental Demonstrations in Oberkochen.

Material in Rebuttal To the Degenhard Report

Huisman Brothers, a New York based diamond cutting firm, sued the Gemological Institute of America in an amount totalling over \$3 million, alleging a conspiracy to prevent their Princess 144-facet round brilliant cut diamond from achieving success in the diamond market.

The Huisman Brothers firm made a claim that their 144-facet diamond is 32% more *brilliant* than a standard 58-facet brilliant. On the basis of the definition of brilliancy given in its *Diamond Dictionary*, published in 1960, several years before the 144-facet cut came on the market, GIA contends that the Huisman Brothers are including *scintillation* in their definition of brilliancy, and that the definition thus adulterated in their report is a definition concocted to further their claim and to mislead the public. GIA disagrees entirely with their definition of brilliancy.

GIA considers this lawsuit entirely without merit and the time and money spent in fighting such a suit although necessary is almost a criminal waste of assets.

Huisman Brothers offered to withdraw their suit if the Institute would

publish in *Gems & Gemology* a report written by Dr. W.E. Degenhard. Dr. Degenhard is the person employed by Huisman Brothers to write their report. GIA agreed to this with the understanding that it would publish a rebuttal written by its expert on cutting effectiveness, Dr. Werner Eulitz. In this issue of *Gems & Gemology*, the report written by Dr. Degenhard appears first, and is followed by Dr. Eulitz's comments in a second article, in which he disputes their claim for added brilliancy.

The Gemological Institute of America finds several faults with the report written by Dr. W.E. Degenhard. It seems clear that he realized from the beginning that the only way in which he could reach a conclusion that would please his sponsors would be to rewrite the definition of brilliancy to include scintillation. The three factors to consider are 1) the efficiency of a diamond as a reflector of white light falling on the crown, 2) its efficiency in dispersing light, and 3) the number of reflections returned to the eye as the stone is moved — the latter of which is *scintillation*. In his report he disregarded the white light reflecting

efficiency of the two styles of cutting and went only to counting the number of reflections from a rotating stone.

In 1919 Marcel Tolkowsky worked out mathematically (what diamond cutters had pretty well learned empirically) that a $40\text{-}3/4^\circ$ or 41° pavilion angle is the most efficient for a diamond. By adding all the facets under the girdle at considerably less efficient angles, the Princess 144 is actually reducing the efficiency of that style of cutting as a reflector. When it is in motion, because there are more facets, it is possible to pick up more reflections, but not as much of the light striking the crown of the stone will return to the eye. Dr. Werner Eulitz calculated that the 144 has an efficiency as a reflector reduced by about 15% from a 58-facet with the pavilion mains on gauge.

There are errors of fact in definitions in the Huisman Brothers report that cast doubt on the knowledge of Dr. Degenhard. For example, in the definition of refraction, he states "if the beam enters under an angle lower than the critical angle, it is *totally* reflected." This is not true for light can enter a diamond from air from any angle. It is only when it attempts to leave the diamond that the quoted statement is true. The whole definition is backward, because the next sentence says, "If the incident angle is larger than the critical angle the beam is refracted toward the normal." Any light entering a diamond other than perpendicular to the surface it enters is refracted toward the normal. He says all beams impinging the surface at angles lower than the critical angle are

totally reflected. This is true only for angles larger than the critical angle and impinging from within the denser medium. He adds to *his* reflection definition "this of course is *also* true for reflections within the medium with higher refractive index." This would appear to suggest that his idea of refraction is mistaken because total reflection occurs *only* within the medium with a higher refractive index.

In his definition of brilliance, Dr. Degenhard says brilliancy is an optical sensation which has not been clearly defined. GIA feels that the definition in the *Diamond Dictionary*, published in 1960, and which was in the *Diamond Course* before that, could not be more definitive in that it clearly distinguishes between brilliancy on the one hand and scintillation and dispersion on the other.

In Dr. Degenhard's attempted measurement of brilliancy, he does nothing but count the number of reflections. His report does not pay any attention to their *intensity*. This is obvious from the graphs that are shown, in which those for the 58-facet cut show intensities that are more evenly distributed and greater than in the 144. Under number 6, "Qualitative Results," the inference is made that more brilliancy is obtained from a hemisphere than from a cone. A hemisphere has a "well" at the bottom that leaks much more light than a cone, and thus the inference lacks scientific foundation.

Dr. Werner Eulitz effectively summarizes the true impact of the Degenhard report in the following article.

The Optical Quality of Two Different Brilliant Cut Diamonds-- A Comparative Investigation

Dr. Werner R. Eulitz*
Gemologist, Mineralogist,
X-ray Cristallographer
January 10, 1973

Preface

The following report, prepared on request of the Gemological Institute of America (GIA), represented by its President, Mr. Richard T. Liddicoat, Jr., Los Angeles, is based upon my knowledge on the subject in general and my independent research on the brilliance of brilliant-cut diamonds in particular.

Two different types of brilliant-cut diamonds are under discussion:

- a) A 58-facet round diamond (58-cut) which is internationally known as the "brilliant."
- b) A modification of the 58-cut to a 106-facet brilliant-cut (106-cut), patented to Huisman Brothers, New York, under U.S. Patent Nr. 3,286,486 on November 22, 1966, which has been supplemented by 38 additional girdle facets according to the Goldstein Patent Nr. 2,340,659, issued on February 1, 1944, to become the so-called "Princess" 144-cut.

The reason for this investigation is the claim of Huisman Brothers that

*For author's credits, see page 283.

the 106- and 144-cut provides higher brilliance of the stone than the 58-cut. The claim of Huisman Brothers is underlined by a report, "GP-2 Goniophotometer Measurements of Brilliance in Diamonds" by Dr. W.E. Degenhard of Carl Zeiss, Inc., New York, Febr. 26, 1971, in the following discussion abbreviated Z. Rep.

The purpose of this investigation is to prove or disprove the claim of Huisman Brothers from a neutral, independent standpoint, which is based upon scientific facts in concurrence with the internationally accepted terminology in this field, however, without any regard for commercial preferences.

Summary

The optical quality of the two brilliant-cut diamonds under investigation, the 58-cut and the 106-cut, has been determined by three independent methods. The three methods and their results are:

- 1) Calculation of the amount of light being reflected (internal

reflections) in percentage of the influx of radiation. The reflectivity of the 58-cut has been found 14.6% higher than that of the 106-cut.

- 2) Calculation of brilliance by application of the brilliance-equation derived and evidenced elsewhere. Result: The brilliance of the 58-cut is between 13.5% and 16.9% higher than that of the 106-cut.
- 3) Intensity evaluation of the recordings attached to the Z. Rep., Figures 4 and 5. Here, the intensity of reflected light by the 58-cut was found 15.8% higher than that of the 106-cut.

The three results obtained from strictly optical considerations in conjunction with the internationally accepted definition of the term "brilliance" of faceted gemstones, definitely prove that the brilliance effect of the 58-cut is, on the average, at least 15% higher than that of the 106-cut. They also are evidence for what is already known by experience, that additional facets below the girdle increase the leakage of light through the pavilion rather than advance the brilliance of the stone.

1. The fundamental criteria of this investigation.

The form and shape of the 58-cut and the 106-cut under discussion are illustrated in *Figure 1*. The crown in both cases is supposed to be the same. The pavilion of the 106-cut has two more different types of facets. All facets are designated by capital letters, the pavilion facets by the letter P ranging from P_1 through P_4 for the

106-cut, and P_1 and P_2 for the 58-cut. The crown facets comprise the main facets (bezel) C_1 , the upper girdle facets C_2 , the star facets C_3 , and the table T. Since no angles for the 58-cut are indicated in the Huisman Brothers patent, nor in the Z. Rep., angles β for the crown facets and angles α for the pavilion facets with reference to the girdle plane G, have been assumed to be those of a good average brilliant-cut. The angles of the pavilion facets for the 106-cut have been obtained from the Huisman Brothers patent description. The profile of the two stones in *Figure 2* (main cross-section A - A of *Figure 1*) shows that the 58-cut and the 106-cut cannot be of equal proportions. An effectiveness-ratio $P_1:P_3$ of the 106-cut has been estimated 80%:20% from *Figure 1* of the Huisman Brothers patent description

The crown of the stone may be considered the "window" for the entering and departing light rays. The pavilion acts like a reflector (angular mirror), thus providing the radiation (reflected light) for the three phenomena: brilliance, fire and scintillation, which are responsible for the delightful appearance of a brilliant.

The brilliance effect is caused by the metallic internal reflections, characteristic for diamond, especially in the main cross section A - A of the stone comprising the table T, the opposite pavilion facets P_1 , and the crown facets C_1 . The intensity of the internal reflections also is responsible for the dispersion (fire, rainbow colors) produced by the upper girdle facets C_2 , and for the scintillation

(sparkling flashes) produced by the star facets C_3 .

All prominent authorities around the world agree that the internal reflections are the primary source of all phenomena involved. So, the term "brilliance" for the internal reflections is justified. The fact that some experts suggest calling the combined effect of the three phenomena the "brilliance" of the stone cannot be considered a lack of uniform definition of the term "brilliance" because, in any case, the intensity of internal reflections is acknowledged as the primary source for the beautiful appearance of a brilliant-cut diamond.

From this point of view, the "definition of brilliance" as given in the Z. Rep., "It seems that . . . a considerable number of reflections with some intensity . . . produce the effect of brilliance," must be considered a devious, rather voluntary interpretation which neglects the internationally accepted terminology. If this "definition" were true, any objective discussion on the subject would be hopeless because the brilliance would be a matter of individual judgment or taste. The term brilliance of a gemstone should not be confused with what is considered "just brilliant" in popular language.

During the past 50 years, much effort has been spent to analyze and to formulate mathematically the conditions for an optimum of the brilliant phenomena. The most important criterion is the refractive index n which for diamond is $n = 2.45$ (violet light). Light rays can enter a stone within a plane of incidence (drawing plane, *Figure 2*) between $+90^\circ$ and

-90° with respect to the normal $N - N$. Due to refraction (Snell's law), these rays are disseminated inside the stone between an angle $+cr$ and $-cr$. Angle cr is the critical angle or the angle of total reflection which is $cr = 24^\circ$ for diamond. However, not all rays between $+cr$ and $-cr$ can be totally reflected by the pavilion facets. *Figure 3* shows that light rays entering at the right side from the normal $N - N$ with an angle $e = -cr$ can all be reflected, while, from the left, only rays up to an angle $e = (\alpha - cr)$ are reflective. Thus, for total reflectivity at the pavilion, the entering angle e can vary within an interval:

$$cr \leq e \leq (\alpha - cr) \quad (1)$$

This gives a total angular margin for reflectivity: $(\alpha - cr) - (-cr) = \alpha$.

Reflections inside the stone follow from the brilliant law:

$$e + r = 2\alpha_1 + 2\alpha_2 + \beta - 180^\circ \quad (2)$$

where e is the angle of the entering ray and r is the angle of the departing ray, both inside the stone. The two different α apply to pavilion reflections from P_1 to P_2 , for example, or P_2P_3 , etc. Reflections back to the table (TP_1P_1T - reflections, entrance at the table, reflected over P_1P_1 and departure at the table) eliminate angle β , since for the table $\beta = 0^\circ$.

2. The reflectivity of the two brilliants.

With the brilliant law, any angle r under which a light ray strikes a crown facet from inside the stone can be calculated if the entering angle e is known. Since the entering angle e can change from $-cr = -24^\circ$ to $(\alpha - cr) = (\alpha - 24^\circ)$, the maximum and minimum of

Table 1

	α_1	α_2	β	r (max)	r (min)	R 100^{α_1}	R%	R% corrected	R% average	Light path				
58-cut	41									Influx	41°			
	41	41	0	+ 8	-33	32	78.0	} 64.6			T			
	41	41	34	+42	+ 1	23	56.0				C ₁			
	41	41	40	+48	+ 7	17	41.5				C ₂			
	41	41	15	+23	-18	41	100.0			C ₃				
	41										Influx	41°		
	41	43	0	+12	-29	36	87.8					T		
	41	43	34	+46	+ 5	19	46.3					C ₁		
	41	43	40	+52	+11	13	31.7					C ₂		
	41	43	15	+27	-14	38	92.6				C ₃			
	43										Influx	43°		
	43	43	0	+16	-27	40	93.0					T		
	43	43	34	+50	+ 7	17	39.5					C ₁		
	43	43	40	+56	+13	11	25.6					C ₂		
43	43	15	+31	-12	36	83.6	C ₃							
106-cut	41									Influx	41°			
	41	41	0	+ 8	-33	32	78.0	} 44.9			T			
	41	41	34	+42	+ 1	23	56.0				C ₁			
	41	41	40	+48	+ 7	17	41.5				C ₂			
	41	41	15	+23	-18	41	100.0			C ₃				
	41										Influx	41°		
	41	46	0	+18	-23	41	100.0					T		
	41	46	34	+52	+11	13	31.7					C ₁		
	41	46	40	+58	+17	7	17.1					C ₂		
	41	46	15	+33	- 8	32	78.0				C ₃			
	46										Influx	46°		
	46	46	0	+28	-18	42	91.2					T		
	46	46	34	+62	+16	8	17.4					C ₁		
	46	46	40	+68	+22	2	4.3					C ₂		
	46	46	15	+43	- 3	27	58.5				C ₃			
	106-cut	41										Influx	41°	
		41	53	0	+32	- 9	33		80.5	} 4.5			T	
		41	53	34	+66	+25	0		0				C ₁	
		41	53	40	+72	+31	0		0				C ₂	
		41	53	15	+47	+ 6	18		43.9			C ₃		
		46											Influx	46°
		46	53	0	+36	-10	34		73.8					T
		46	53	34	+70	+24	0		0					C ₁
		46	53	40	+76	+30	0		0					C ₂
46		53	15	+51	+ 5	19	41.3		C ₃					
41											Influx	41°		
41		59	0	+44	+ 3	21	51.2					T		
41		59	34	+78	+37	0	0					C ₁		
41		59	40	+84	+43	0	0					C ₂		
41		59	15	+59	+18	6	14.6				C ₃			
46											Influx	46°		
46	59	0	+54	+ 8	16	34.8			T					
46	59	34	+88	+42	0	0			C ₁					
46	59	40	+94	+48	0	0			C ₂					
46	59	15	+69	+23	1	2.2			C ₃					
									50.0					

Additional pavilion facets P₃ and P₄.

Reflectivity R% } 58-cut: 64.6%
 } 106-cut: 50.0%

Result: The reflectivity of the 58-cut is 14.6% higher than that of the 106-cut.

AGE ————— 24° ————— $\frac{R}{100} \cdot \alpha_1$ ————— 24° LEAKAGE
 60° 40° 20° $+ 0^\circ - 20^\circ$

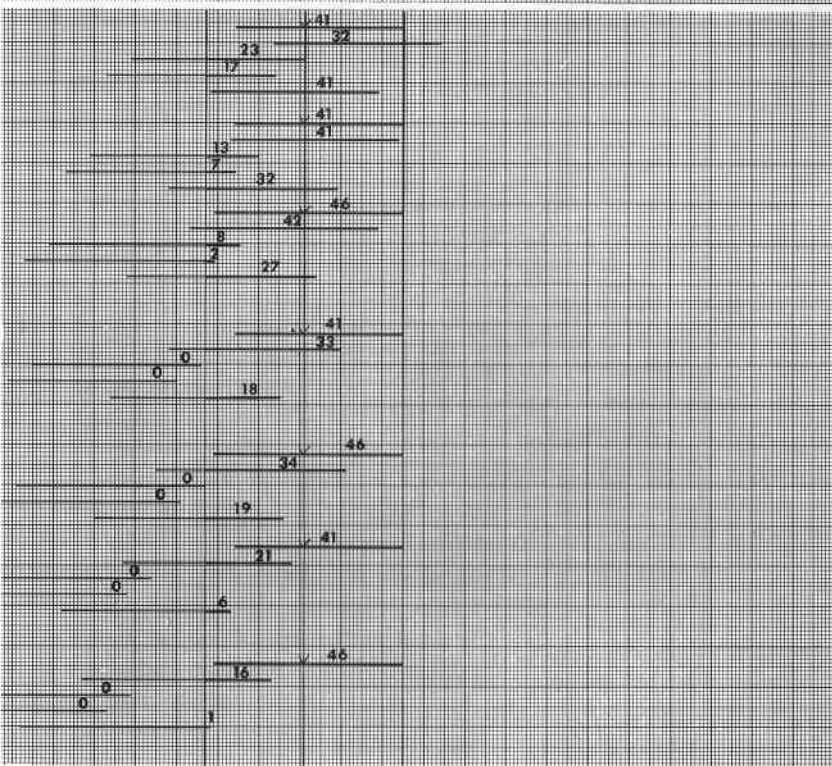
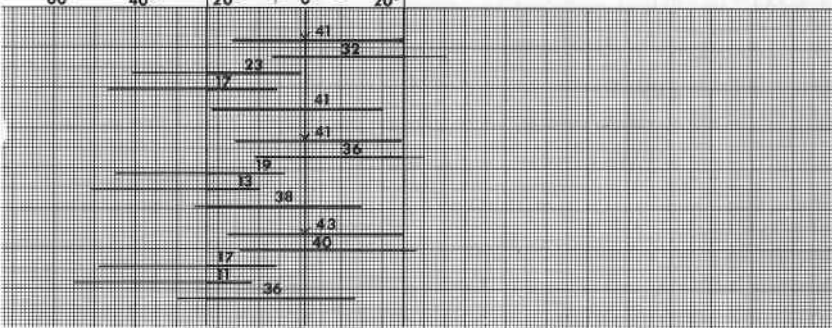

TABLE I

Brilliant Law: $e + r = 2\alpha_1 + 2\alpha_2 + \beta - 180^\circ$

e = angle of entering ray inside the stone

cr = critical angle = 24° for diamond

r (max) = $2\alpha_1 + 2\alpha_2 + \beta + 24^\circ - 180^\circ$

($e = cr = -24^\circ$)

r (min) = r (max) - α_1

$R\% = \left(\frac{R}{100} \cdot \alpha_1\right) \cdot \frac{100}{\alpha_1} \leq 100$

Limitation of e for reflectivity:

$-cr \leq e \leq (\alpha - cr)$

r = angle of departing ray inside the stone

R = reflectivity in percentage of influx ($= \alpha_1$)

Table to table reflections:

$$\frac{R}{100} \cdot \alpha_1 = 24^\circ + r \text{ (max)}$$

Table to crown reflections:

$$\frac{R}{100} \cdot \alpha_1 = 24^\circ - r \text{ (min)}$$

angle r follow by substituting e (min)
 $= -cr$, and $e(\max) = (\alpha - cr)$:

$$\begin{aligned}
 e(\min) + r(\max) &= 2\alpha_1 + 2\alpha_2 + \beta - 180^\circ \\
 \text{and } e(\max) + r(\min) &= 2\alpha_1 + 2\alpha_2 + \beta - 180^\circ \\
 \text{thus, } r(\max) &= 2\alpha_1 + 2\alpha_2 + \beta + cr - 180^\circ \quad (3) \\
 \text{and } r(\min) &= 2\alpha_1 + 2\alpha_2 + \beta - \alpha_1 + cr - 180^\circ \\
 &= r(\max) - \alpha_1 \quad (4)
 \end{aligned}$$

Rays reflected to the crown facet from inside the stone, likewise, can escape to the outside only, if their angle of incidence r is within the margin $-cr$ (-24°) and $+cr$ ($+24^\circ$).

This interrelation is depicted in *Table I* for the major light paths of the 58-cut and the 106-cut. The light paths are indicated by a 4-letter designation as explained earlier in this report. The facet angles α and β for the facets involved (*Figure 1*) are listed in the first three columns. The maxima and minima for r (angle of outgoing ray), calculated with equations (3) and (4), follow in columns 4 and 5, respectively. The angles of reflectivity are marked at the right side by horizontal straight lines indicated the influx (α_1) at the top of each group of reflections. The "window" for the escaping rays is framed by vertical lines at $+24^\circ$ and -24° . The center line 0° shows the point of vertical incidence ($e = 0^\circ$). The reflectivity $R\%$ with respect to the influx ($= \alpha_1$) follows from the graph.

It is interesting to note a major shift of the reflectivity to the left (positive side) with the result that no reflections from the additional pavilion facets P_3 and P_4 of the 106-cut can escape through the main crown facets C_1 and C_2 .

Light rays of highest intensity ($e =$

0° , vertical incidence) are indicated in *Table I* by a little arrow in the zero-point of the influx-line of each group of reflectivity. The angle under which such a ray of highest intensity strikes the table or a crown facet is marked by a dot on the reflection line of each of these facets. A survey of these dots already shows qualitatively that the brilliance (back reflection of high intensity rays) is better for the 58-cut than for the 106-cut.

3. The calculation of brilliance.

The intensity of a reflected ray and a refracted ray in percentage of that of the original ray changes with the angle of incidence. The optical mechanism involved is described by a series of equations which are known in physics as the Fresnel - equations. The intensity of the penetrating ray is highest at vertical incidence. In a brilliant-cut diamond, such a ray of zero-incidence is reflected to a crown facet with angle r and departs to the outside with an angle d (in air) which follows from Snell's law:

$$\sin d = n \cdot \sin r$$

The intensity of the departing ray (in air) has, according to Fresnel's equations, two components, one which refers to the sine function of the departure angle d , and another which refers to $\cos d$. The theory of maxima

TABLE II.

The calculation of brilliance B%. $\sin d = n \cdot \sin r$ $n = 2.45$

Light path	r	sin d	cos d	B	B%						
<u>58-cut</u>											
TP ₁ P ₁ T	16°	0.676	0.737	0.5	50%						
TP ₁ P ₁ C ₁	18°	0.757	0.653	0.49	49.5%						
B% TOTAL					99.5%						
<u>106-cut</u>						P ₁ /P ₃ ratio					
					60/40	70/30	75/25	76.5/23.5	80/20	90/10	
TP ₁ P ₁ T	16°	0.676	0.737	0.5	30%	35%	37.5%	38.3%	40%	45%	
TP ₁ P ₁ C ₁	18°	0.757	0.653	0.495	29.7%	34.7%	37.1%	37.9%	39.6%	44.6%	
TP ₁ P ₃ T	8°	0.341	0.94	0.321	12.9%	9.6%	8.0%	7.5%	6.4%	3.2%	
TP ₁ P ₃ C ₁	0	0	0	0							
B% TOTAL					72.6%	79.3%	82.6%	83.7%	86.0%	92.8%	
<u>Difference to 58-cut</u>					26.9%	20.2%	16.9%	15.8%	13.5%	6.7%	

and minima states that in such a case a maximum is obtained by the product $\sin d \cdot \cos d$. This law can be applied to determine the brilliance (highest intensity of internal reflections) of a brilliant-cut diamond where the main cross section of the stone is primarily responsible for the total brilliance effect.

The 58-brilliant cross section A - A (Figure 1) comprises the pavilion facets P₁ and the crown facets T and C₁. The 106-cut, in addition, has the pavilion facet P₃.

From the 58-cut, two types of reflections (light paths), TP₁P₁T and TP₁P₁C₁, contribute to the brilliance effect. The 106-cut provides four types of reflections: TP₁P₁T, TP₁P₁C₁, TP₁P₃T, and TP₁P₃C₁, where the TP₁P₃C₁ - path gives no reflections at all according to Table I. For the remaining three light paths of the 106-cut, the percentage-ratio of facets P₁:P₃, being effective for reflections, is of major importance. In Table I, this ratio has been assumed 80% for

P₁ and 20% for P₃. In order to realize the influence of this ratio P₁/P₃ where (P₁ + P₃) = 100%, several ratios have been considered in Table II.

The angles r for the outgoing rays can be obtained from Table I or, more precisely, from the brilliant equation substituting $e = 0^\circ$ (zero incidence at T). The angle d of the departing ray in air follows from Snell's law as discussed above.

The product $\sin d \cdot \cos d$ gives the component of brilliance for each light path, and the sum of the two components of the 58-cut multiplied by 100 is the total brilliance in percentage. In the case of the 106-cut, the remaining three components have to be multiplied according to the P₁/P₃ - ratio, i.e. the P₁P₁ reflections with the P₁-percentage and the P₁P₃ reflections with the P₃-percentage as indicated in Table II.

Comparing the varying results obtained for the 106-cut with the 99.5% brilliance of the 58-cut, it is clear that the total brilliance of the 106-cut is in

all cases lower than that of the 58-cut. It also is apparent that the difference decreases with decreasing size of the P_3 facet which proves again (see *Table I*) the adverse effect of the additional pavilion facets.

Keeping further in mind that reflections from a P_3 -facet of 20% or less cannot reach the table for geometrical reasons, but only the crown facet C_1 , where they are totally reflected back into the stone, and, on the other hand, that a size of more than 25% for the P_3 -facet is out of consideration, the actual difference of brilliance can be expected between 13.5% and 16.9% in favor of the 58-cut. The difference of 15.8% obtained from measurements discussed in the next section corresponds to a P_1/P_3 -ratio of 76.5%:23.5%, which means either the actual size of the P_3 -facet is probably about 23.5% of the reflective area of the pavilion, or the actual angles α and β of the stones compared in the Z. Rep. are more disadvantageous than the angles assumed in this investigation.

4. Evaluation of the intensity measurements presented in the Zeiss Report

The GP2 — Goniophotometer is designed for intensity measurements as indicated by the name of the instrument. So, it is not readily conceivable why the author of the Z. Rep. uses this instrument for counting the number of reflections which could be done by a much simpler method as, for example, the "Reflektograph," suggested by S. Roesch in 1925.

In order to retrace the result of the Z. Rep., two recordings of the Goniophotometer attached to this report

have been evaluated for the "number of reflections." Since these two recordings are typical for the 58-cut (*Figure 4*) and for the 106-cut (*Figure 5*) as stated by the author of the Z. Rep., the number of reflections — ratio in these recordings should at least approximate the final result (32% brilliance in favor of the 106-cut) presented in the Z. Rep.

The number of reflections within 15 horizontal scale divisions have been counted. The 58-cut recording shows a total of 138 reflections and that of the 106-cut reveals 141 reflections. Thus, the number of reflections in these two typical recordings is practically the same. This result is not surprising, since with reference to the discussion in section 2 and *Table I* of this report, the additional pavilion facets of the 106-cut and, with the same evidence, 38 additional girdle facets which modify the 106-cut to a 144-cut cannot increase the number of reflections for optical reasons.

The fact, emphasized in *Figure 3* of the Z. Rep., that the modified pavilion turns the reflections more to the center of the stone (table reflections) is not caused by the additional pavilion facets P_3 and P_4 , and especially not by girdle facets (144-cut), but by the pavilion facets P_2 which are cut with an angle larger than 45° (see *Figure 1c*). In this case the focal point for the entering and departing ray is in front of (not behind) the stone; thus, the rays are reflected toward the table.

The impossibility of retracing the result of the Z. Rep. properly, challenged the evaluation of the two

TABLE III.

	<u>58-cut</u>	<u>106-cut</u>
Total of vertical scale divisions	3222	2247
Number of deflections	99	82
Average intensity (scale division/deflection)	32.6	27.4
Intensity percentage	100 %	84.2%
Difference in favor of the 58-cut		<u>15.8%</u>

recordings of the Z. Rep. for what they actually indicate, the intensity of reflections. In order to avoid confusing ground reflections, only reflections larger than 20 divisions on the vertical scale have been considered. The deflections of the recorder pin have been read from the vertical scale, 20 scale divisions subtracted (ground reflections), all readings summed up, and divided by the total number of deflections. The result of this procedure is depicted in *Table III*.

A first look at the recordings, *Figures 4 and 5* in the Z. Rep., already gives the striking impression that the 58-cut (*Figure 4*) is better than the 144-cut (*Figure 5*). Subdividing the 15 horizontal scale divisions of each recording into 3 partitions of 5 scale divisions, the recording of the 58-cut shows clearly three distinct areas in which the intensities are evenly centered about a maximum intensity. In

Figure 5, the recording of the 144-cut, the intensities are more or less unevenly disseminated with an obvious congregation at the center of the stone (right side of the recording), while the outside area (left side) indicates only very low intensities. This proves again the earlier statement of this report that the reflections of the 106-cut are turned toward the center (table) of the stone due to the large angle of the pavilion facets P_2 , while reflections through the crown facets are reduced due to the inefficacy of the additional pavilion facets P_3 and P_4 as illustrated in *Table I*.

The conformity in the order of magnitude of the theoretical results with the practical measurements simultaneously indicates that the Zeiss Goniophotometer—GP2 appears to be a suitable instrument for determining the optical quality of faceted gemstones.

Signed

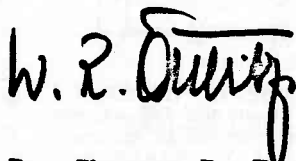

Dr. Werner R. Eulitz

Huntsville - Alabama

January 10, 1973

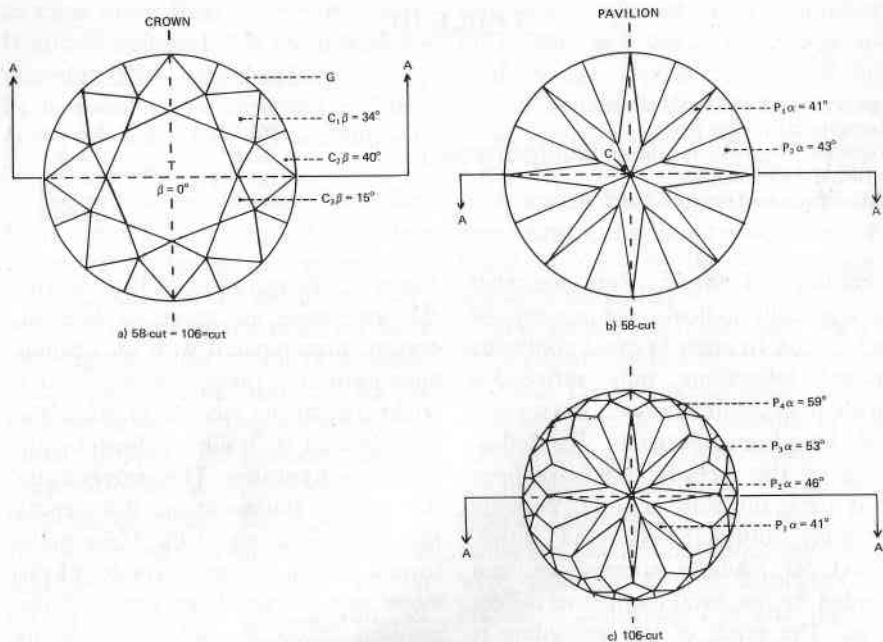

Figure 1.

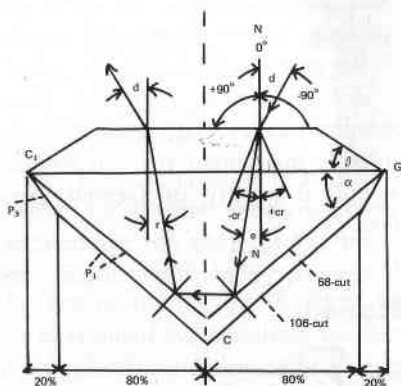

Figure 2. Cross section A - A of Figure 1 shows profiles of 58-cut and 106-cut, and distribution of radiation inside the stone from $-cr$ to $+cr$.

$cr = 24^\circ$ - critical angle.

$N - N$ = Normal (vertical line to the surface) from which all angles are measured.

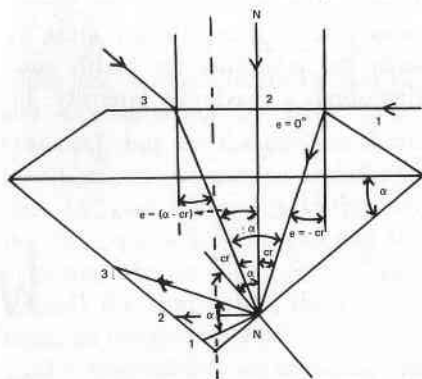

Figure 3. Limitation of reflective radiation inside the stone: $-cr \leq e \leq (\alpha - cr)$

EDITOR'S NOTE

Dr. Werner R. Eulitz was born in Germany in 1903. He studied physics, mathematics, chemistry and mineralogy at Leipzig University where he received his PhD degree for a study in x-ray crystallography. While at the University, he developed new methods to evaluate x-ray powder patterns. During World War II, while at the Peenemuende Rocket Center, he was involved in numerous research and development projects, such as spectrographic methods for quantitative materials analysis and the development of hydrodynamic principles related to vortexing of rocket propellant that are still applied to present-day booster vehicles.

Since 1956, Dr. Eulitz has been active in various facets of advanced space research, initially at the U.S. Army Ballistic Missile Agency at Huntsville, Alabama, and since 1960 at NASA, Marshall Space Flight Center (MSFC), where he conducted numerous experimental and theoretical studies ranging from liquid oscillations in missiles to crystal growing under the state of weightlessness. Some of his significant research included high vacuum pumping systems and sealing methods for evacuating large-scale vacuum chambers, studies on friction and lubrication in space-exposed bearings, development of preventive methods for surface tension effects under weightlessness, and studies on theoretical considerations of human movement under the reduced gravity of the moon. Dr. Eulitz became an

American citizen in 1961 and retired from civil service at NASA-MSFC in 1970.

He has published a number of NASA technical reports on a wide variety of subjects and has received numerous awards for his scientific excellence. In 1969 he was presented the Apollo Achievement Award by NASA. While working at NASA — Marshall Space Flight Center, Dr. Eulitz successfully completed the GIA courses in Diamond Appraisal, Colored Stones, and Gem Identification in 1968. During that time and up to the present he has continued studies on the theory of brilliance.

His long-continued interest in optical phenomena in crystals, starting in University days, stimulated his ongoing research on the problems of brilliance in faceted gemstones. The results of some of his gemological/optical physics studies pertinent to this article are:

1. "The Optics of Brilliant-Cut Gemstones"; *Gems & Gemology*, Spring issue, 1968.
2. Comments on Dr. S. Suzuki's "A New Design for Brilliance plus Dispersion"; *The Australian Gemmologist*, May issue, 1970.
3. "Die Rechnerische Ermittlung der optimalen Brillanz des Brillanten" (The Calculation of Optimum Brilliance of the Brilliant); *Zschr. d. deutsch. Gemmolog. Ges.*, Vol. 21, Nr. 1, March 1972.

World Diamond Production - 1973

(Ed. note: Reprinted from Mineral Trade Notes, U.S. Department of the Interior, Bureau of Mines, Vol. 71, No. 7, July 1974.)

Total world production of diamond (natural) decreased approximately 83,000 carats in 1973 from the previous year, according to preliminary data compiled by the Bureau of Mines. The Republic of the Zaire, the

U.S.S.R., the Republic of South Africa, Ghana, and Botswana were the principal sources of industrial diamond; the Republic of South Africa, the U.S.S.R., Angola, South-West Africa, and the Republic of the Zaire were the leading producing countries of gem-quality diamond. World diamond production by country is shown in the following table:

World production, by country 1/
(Thousand carats)

Country	1971			1972			1973 ^{d/}		
	Gem	Industrial	Total	Gem	Industrial	Total	Gem	Industrial	Total
Africa:									
Angola	1,810	603	2,413	1,616	539	2,155	1,594	531	2,125
Botswana	82	740	822	360	2,043	2,403	362	2,054	2,416
Central African Republic	r/304	r/164	r/468	346	178	524	251	129	380
Ghana	256	2,306	2,562	266	2,393	2,659	270	2,430	e/2,700
Guinea ^{g/}	22	52	74	25	55	80	25	55	80
Ivory Coast	130	196	326	134	200	334	120	180	300
Lesotho ^{2/}	1	6	7	1	8	9	1	9	e/10
Liberia	3/532	3/277	3/809	3/414	3/350	3/764	450	370	e/820
Sierra Leone	r/778	r/1,168	r/1,946	720	1,080	1,800	4/670	4/1,000	e/4/1,670
South Africa,									
Republic of:									
Premier mine	609	1,828	2,437	613	1,841	2,454	625	1,876	2,501
Other De Beers Company ^{5/}	2,162	1,769	3,931	2,289	1,872	4,161	2,368	1,938	4,306
Other	398	265	663	468	312	780	368	245	e/613
Total	3,169	3,862	7,031	3,370	4,025	7,395	3,361	4,059	e/7,420
South-West Africa,									
Territory of	1,566	82	1,648	1,516	80	1,596	1,520	80	1,600
Tanzania	419	418	837	4/326	4/325	4/651	290	290	e/580
Zaire	r/1,274	r/11,469	r/12,743	1,339	12,051	13,390	1,294	11,646	12,940
Other areas:									
Brazil ^{e/}	150	150	300	155	155	310	160	160	320
Guyana	19	29	48	20	29	49	21	31	e/52
India	16	3	19	17	3	20	18	3	21
Indonesia ^{e/}	12	3	15	12	3	15	12	3	15
U.S.S.R. ^{e/}	1,800	7,000	8,800	1,850	7,350	9,200	1,900	7,600	9,500
Venezuela	114	385	499	141	315	456	241	537	778
World total	r/12,454	r/28,913	r/41,367	12,628	31,182	43,810	12,560	31,167	43,727

^{e/} Estimate. ^{B/} Preliminary. ^{I/} Revised.

^{1/} Total (gem plus industrial) diamond output for each country is actually reported except where indicated to be an estimate by footnote. In contrast, the detailed separate reporting of gem diamond and industrial diamond represents Bureau of Mines estimates in the case of all countries except Lesotho (1971 and 1972), Liberia (1971 and 1972), and Venezuela (1971 and 1972), where sources give both total output and detail. The estimated distribution of total output between gem and industrial diamond is conjectural in the case of a number of countries, based on unofficial information of varying reliability.

^{2/} Exports of diamond originating in Lesotho; excludes stones imported for cutting and subsequently reexported.

^{3/} Exports for year ending August 31 of that stated.

^{4/} Exports.

^{5/} All company output from the Republic of South Africa except for that from the Premier mine; also excludes company output from the Territory of South-West Africa and from Botswana.

Book Reviews

AN ILLUSTRATED DICTIONARY OF JEWELLERY, by Anita Mason and illustrated by Diane Packer, Harper & Row, Publishers, New York. 1974. 390⁺ pages with numerous line illustrations. Price: \$8.95.

In addition to being a dictionary, this book is also a jeweler's encyclopedia. Over 2,000 entries have been alphabetically arranged and extensively cross-referenced for the user's convenience. This interesting and well-produced text is a most useful addition to the jewelry trade. The line drawings which illustrate it are well done, and the type and organization make it easy to read. Definitions are concise, well-written and there seem to be no major discernible errors in fact.

An Illustrated Dictionary of Jewellery appears to cover every aspect of jewelry making. The entries include tools and techniques, gemstones, precious and nonprecious metals, the history of jewelry from its inception to the present day, biographies of notable jewelers of the past, and other practical information

as well as background information on such topics as folklore, chief characteristics in each historical period, and significant chronological events on each subject. The book is basically a practical reference work for craftsmen in the jewelry trade, students of jewelry design, gemologists, and others interested in this art form. Of great interest to the jeweler and gemologist are the entries on individual gemstones which describe the physical characteristics of the stones, the manner in which they are usually cut and set, their use past and present, and various popular beliefs associated with gems. Lacking from the text are some recent developments in the jewelry trade and references to many of the new synthetics that have been made in the last few years, e.g., the text states that there is no synthetically made turquoise. Actually, synthetic turquoise and other synthetic gem materials not listed in the text have been on the market for a year or more.

A scholarly bibliography of selected English titles makes the dictionary most valuable and useful for English reading audiences. Although written in

England with a distinctive British flavor, this attractive and inexpensive book should find acceptance wherever it is sold.

R.A.P.G.

Comment Acheter Ses Bijoux, by Pierre Paquet, Editions du Jour, Montreal, Canada, 1974. 86 pages. Paperback, Price \$3.50. In French.

Comment Acheter Ses Bijoux (How To Buy Your Jewelry), is written in French for the French-Canadian speaking consumer.

In the introduction, Monsieur Paquet explains the purpose of the book when he says, "The consumer has a right to have access to the knowledge which will permit him to make a judgment on the various items offered." And this is what he attempts to do in the 10 short chapters. M. Paquet uses simple nontechnical language wherever possible.

The first chapter deals with the different qualities of mountings from gold filled to solid gold, together with

an explanation of the meaning of the various karat ratings of gold alloys. Chapter 2 is devoted to earrings with particular emphasis placed on the precautions which should be taken with regard to piercing ears. Chapter 3 is concerned with rings for men, women, and children with comments on quality, styles and workmanship. Care in sizing, particularly with regard to rings for infants, is stressed.

The remaining chapters briefly discuss the factors to consider when buying diamonds and other colored stones. The aesthetic considerations of the various styles, repairs and the care of jewelry, and references to sales and exchange practices of jewelry stores. The final chapter is the author's advice on what to consider and how to select a jeweler either for the purchase of something valuable or for satisfactory repair work.

This book appears to be a forthright attempt on the part of Monsieur Paquet to disclose the problems and difficulties that the consumer may encounter in the purchase of jewelry items and how to overcome them.

B.B.

In Memoriam



JEANNE G. M. MARTIN

It is with deep regret that we announce the passing of Jeanne G.M. Martin, F.G.A., C.G., G.G., recently of Moab, Utah, on June 5, 1974, at the Allen Memorial Hospital, Moab, Utah.

Jeanne Martin was well known as a gemologist, a teacher, a photographer, and for her artistic talent, especially her recent acrylic landscape paintings of the locale around Moab, Utah. She was born and grew up in Rushville, Indiana, and in 1929 moved to Seattle, Washington, where she managed a glove factory with 80 employees. In

1944, she moved to San Diego, California, and became an active member of the San Diego Mineral and Gem Society, where she acted part-time as a faceting instructor. While in San Diego, she took local courses in gemology taught by the late Charlie Parsons. By 1951, she was enrolled in the gemological courses of the Gemological Institute of America and in 1953 she was granted a diploma in the Theory of Gemology. In May of the same year, she took and successfully passed the British examination in gemmology and received her Fellowship Diploma With Distinction.

After completing her resident classes with the GIA in Los Angeles, she was awarded the Graduate Gemologist Diploma. Because Jeanne was an outstanding student and an exceptionally capable gemologist, she was offered and accepted a position on the staff of GIA. Jeanne was an amazingly versatile person and during her time at GIA took on and excelled in many tasks. Although she had no formal experience in publications, she became Associate Editor of *Gems & Gemology* and coordinated and helped edit many books, including *The Jewelers' Manual*, *Diamonds . . . Famous, Notable, and Unique*, *The Diamond*

Dictionary and several editions of the *Handbook of Gem Identification*. In 1955, while working with the GIA, she was also granted the title of Certified Gemologist from the American Gem Society.

All during her stay with GIA she worked closely with resident students as an instructor of gem identification and colored stones, making hundreds of friends in the process – because of her exceptional patience and understanding of beginners' problems. During her years at GIA, she became as accomplished a gem photographer as any we knew, and Jeanne was responsible for having taken most of the superb photographs of the fine colored stones currently in the Institute's files.

After twelve notable years at the Institute, she retired from the GIA in

1968 and moved to Monument Valley, Utah, where she worked for a time as an assistant operational manager of Goulding's Trading Post and Lodge. Later she moved to Moab, Utah, where the high, dry climate seemed to agree with her, and she enjoyed painting acrylic landscapes of the surrounding scenery and grew her favorite African violets.

Jeanne is survived by two daughters, Mrs. Denzil (Mona) Osborne, Bremerton, Washington, and Mrs. Juanita Schiano, San Diego, California; four grandchildren and ten great-grandchildren; her two sisters, Mrs. Samuel (Mildred) Turner, Connersville, Indiana; and Mrs. George (Elizabeth) Rill of Rushville, Indiana.

Former students, associates and staff alike will certainly miss her and remember her with great fondness.

●

ERRATUM: In the Winter 1972-73 *Gems & Gemology*, memorial tribute to Dr. Edward H. Kraus, on page 126, Dr. Kraus was listed as graduating from the University of Rochester, which is in error. We stand corrected, he graduated from Syracuse University.

●