

# Gems & Gemology

---

GEMS & GEMOLOGY is the quarterly official organ of the Gemological Institute of America. In harmony with its position of maintaining an unbiased and uninfluenced position in the jewelry trade, no advertising is accepted. Any opinions expressed in signed articles are understood to be the views of the author and not of the publishers. Subscription price: \$3.50 a year.

---

Robert M. Shipley, Editor

---

VOLUME V

FALL, 1946

NUMBER 7

---

| <i>In This Issue:</i>  | <i>Page</i> |
|--|-------------|
| John Wesley Ware.....  | 338         |
| Introduction to X-ray Methods of Gem Identification,<br><i>George Switzer, Ph.D.</i> ..... | 339         |
| Gemological Digests.....   | 346         |
| Identification of Synthetic Gems, Part I<br><i>Richard T. Liddicoat, C.G.</i> .....        | 349         |
| Diamond Glossary.....  | 355         |

*Published by*

THE GEMOLOGICAL INSTITUTE OF AMERICA  
(UNITED STATES AND CANADA)

*Established 1931*

541 South Alexandria Ave.



Los Angeles 5, California

## John Wesley Ware

In the recent death of Mr. J. W. Ware, the gemological profession is deprived of an ally, the imprint of whose thought and accomplishment is indelible.

Mr. Ware was among the small band of California jewelers who early in 1931 assisted Robert M. Shipley in founding the Gemological Institute of America by becoming its first Sustaining Member. He served four terms as Governor of the Gemological Institute. From the founding of the American Gem Society in 1934, he was a Charter Member, and was one of five directors from its incorporation in 1938 until his death. Elected President of the Board in 1943, he served efficiently until his resignation in February 1944 because of illness.

Mr. Ware became one of America's first Certified Gemologists (No. 42). He was one of five students in the first advanced laboratory courses

of the Gemological Institute. Like many other American jewelers, he participated in the activities of the gemological profession with religious fervor, his interest mounting steadily during the fifteen years since the founding of the Institute. He was directly responsible for scores of new students of gemology.

A Wisconsin jeweler, he came to San Diego, over forty years ago and established the successful retail business that bears his name. His only near relatives, his wife and a daughter by a previous marriage, continue this business in which Mrs. Ware became his partner several years ago.

Also owned and operated by Mr. Ware were two of

the few profitable Southern California gem mines, the product of which he lapidated and made into jewelry in his own shops. From these mines he had given to the Gemological Institute the most valuable group of gemstones in its collection.



# Introduction to X-ray Methods of Gem Identification

by

GEORGE SWITZER, Ph.D.  
*Director of Research*  
*Gemological Institute of America*

On November 8, 1895, Wilhelm Konrad Roentgen, professor of physics at the University of Würzburg, Germany, connected the terminals of a high-voltage generator with electrodes in an evacuated glass bulb. While performing various experiments he noticed that although the glass bulb was covered with black paper, it caused a nearby fluorescent screen to glow. Thus he discovered an invisible radiation capable of passing through black paper or any other solid object. These new rays he called *x-rays*, because of their unknown nature. Today, even though their nature is better understood, they are still called either x-rays, or Roentgen rays in honor of their discoverer.

The value of this momentous discovery by Roentgen cannot even now be estimated. It opened up new fields of research in physics, chemistry, mineralogy, and medicine, and has come to be of tremendous practical importance in medicine and industry.

## Nature of X-rays

It is now known that x-rays are identical in nature with visible light, differing only in wave length. Gamma rays (emitted by radium), x-rays, ultra-violet, visible and infra-red rays, and radio waves, all belong to the electromagnetic spectrum, and differ only in wave length. In terms of Angstrom units, which

is the unit of length commonly used to measure such quantities (one Angstrom unit equals one ten-millionth of a millimeter), the wave length of the better known members of the electromagnetic spectrum are as follows:

| <i>Radiation</i>             | <i>Wave Length in Angstrom Units</i>                    |
|------------------------------|---|
| Gamma rays                   | 0.01-1.4  |
| X-rays (commonly used)       | 0.06-6.0  |
| Ultra-violet rays            | 136-3,900   |
| Visible rays                 | 3,900-7,700   |
| Infra-red rays               | 7,700-4,000,000   |
| Radio waves (broadcast band) | 2,000,000,000,000 to 5,500,000,000,000 (200-550 meters) |

A study of the comparative wave lengths of x-rays and visible light immediately suggests the practical uses that may be made of x-rays. Since x-rays of the commonly used wave lengths are approximately 1/7000th as long as visible light, x-rays may be expected to penetrate materials that are opaque to light. X-rays are able to far surpass the finest microscope and take the investigator down to the very atoms making up solid matter, because the spacing between atoms is of the same order of magnitude as the wave length of the x-rays.

### Production of X-rays

When a high-velocity stream of electrons strikes a target of suitable material, x-rays are produced. The electrons are brought to a sudden stop upon striking the target, and their energy is transformed partially into heat and partially into x-radiation moving out from the target.

The type of x-ray tube now in general use employs a heated filament to generate the electrons, which move through an evacuated glass bulb to strike a metal target. The x-rays generated are radiated out from the target and pass through the glass of the tube into the surrounding air.

The filament is analogous to an electric light bulb in that it consists of a coil of tungsten wire heated to a white heat by an electric current flowing through it. Since the electrons emitted by the filament are negatively charged, they may be made to move with high velocity toward the target by applying a very high voltage across the filament and target. Voltages commonly used for this purpose will range from 50,000 volts in small laboratory units to several million volts in huge hospital installations. The glass bulb must be highly evacuated in order that the motion of the electrons will not be hindered by the atoms of air that would normally fill the tube. The heat generated by impact of electrons on the target is commonly conducted away by a water cooling system.

A schematic diagram of an x-ray tube is shown in Figure 1.

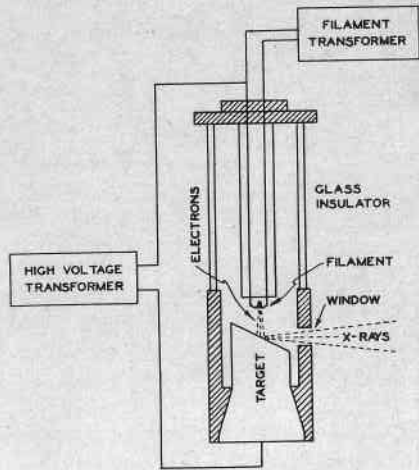

Figure 1

### Schematic Diagram of X-ray Tube

The wave length of x-rays is dependent on the target material, the common targets being iron, copper, molybdenum, and tungsten. The choice of target depends on the type of work for which the x-rays are to be used. For industrial and medical radiography the target is usually tungsten, while for studies of atomic structure of crystalline solids (including minerals) a copper target gives best results.

The wave lengths of x-rays generated by causing high-velocity electrons to strike various targets are given below:

| Target     | Wave Length<br>(K $\alpha$ Doublet)<br>Angstrom Units |
|------------|---|
| Iron       | 1.935   |
| Copper     | 1.539   |
| Molybdenum | 0.710   |
| Tungsten   | 0.200   |

### Diffraction of X-rays by a Crystal

In 1912, Laue, a physicist at the University of Munich, conceived the idea that a crystal, consisting of an orderly arrangement of atoms, might act as a three-dimensional diffraction grating for x-rays. His idea was carried out by Friedrich and Knipping with complete success, and the way was thus paved for important research in the atomic

Further measurements of the distance of the secondary spots from the center yield information regarding the spacing between planes of atoms. Photographs obtained by this method are called *Laue photographs*, in honor of that physicist. In Figure 2, the appearance of a typical Laue photograph is shown schematically on the far right.

In any x-ray photograph such as

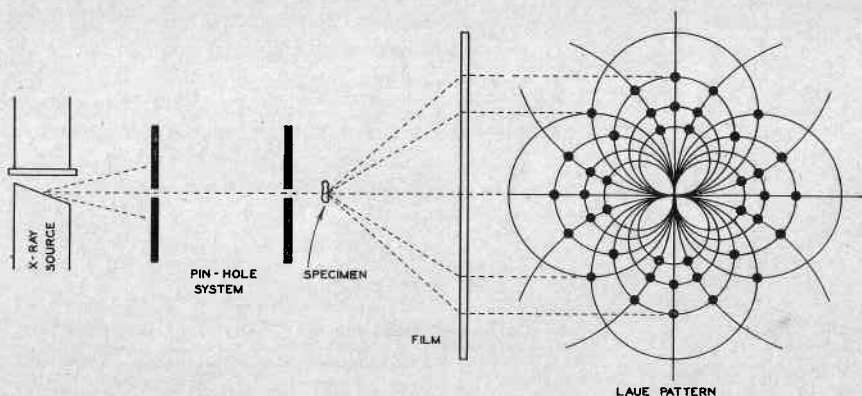

Figure 2

### *Schematic Diagram of a Laue Camera and typical Laue photograph*

structure of solids, and for the development of the methods of identification by x-rays to be outlined in the following paragraphs.

The Laue method of obtaining an x-ray photograph of a crystal is shown schematically in Figure 2. The resultant photograph consists of a large central spot produced by the direct x-ray beam, surrounded by smaller spots due to secondary beams which are produced by reflections from internal planes of atoms. The manner in which the secondary spots are arranged around the center indicates the crystal system to which the crystal belongs.

the Laue type, the spots surrounding the center of the film are the result of secondary beams of x-rays having blackened the film. The secondary beams are originated by diffraction. This diffraction is caused by the precise, orderly arrangement in space of the atoms making up the solid. For simplicity, the secondary x-ray beams can be thought of as being the result of **reflection from planes of atoms within the crystal**. It is evident from this that only crystalline materials will give x-ray diffraction patterns. Amorphous substances such as opal and amber, because their atoms are disordered

and do not lie in definite planes, cannot produce an x-ray pattern.

By measuring the angle through which the secondary x-ray beam has been diffracted, and knowing the wave length of the x-rays being used, it is possible to calculate the spacing between the family of atomic planes responsible for each spot on the photograph. The formula used for this calculation, known as *Bragg Equation* (after Sir William C. Bragg, English physicist) is:

$$n \lambda = 2 d \sin \theta$$

where  $n$  = number of the atomic plane from which reflection takes place.

$\lambda$  = wave length of the x-rays

$d$  = spacing between atomic planes

$\theta$  = angle through which x-rays are diffracted

### Methods Used

The numerous methods which have been devised for the study of solids by x-rays may be roughly grouped into two categories, as follows:

#### I. X-ray diffraction methods

A. Purpose to determine manner in which atoms of a solid body are arranged in space.

1. Laue method.
2. Rotating crystal method.

B. Purpose to identify an unknown substance.

1. Powder method.

#### II. Radiography

There is some overlap between A and B in the above classification because the Laue method is sometimes used for identification, and the

powder method is sometimes used to study the atomic arrangement of solids. They are most often used, however, for the purposes outlined above.

The technique of radiography differs fundamentally from the other methods, as will be explained later.

*Laue Method:* The Laue method has already been explained in some detail and the equipment used for the production of Laue patterns is shown schematically in Figure 2. This was the first method used to study the arrangement of atoms within a crystal, but is limited in its usefulness for several reasons. To obtain a good Laue photograph it is necessary to have an oriented, single crystal, or crystalline aggregate made up of parallel or nearly parallel crystals. Given a single crystal of known orientation, it is possible to obtain a Laue pattern which will indicate the crystal system to which a substance belongs. It is difficult, however, to make calculations regarding the atomic spacings from a Laue pattern because x-rays of many wave lengths must be used to produce a good pattern, and the quantity in the Bragg equation is therefore unknown.

Laue patterns are of greatest interest to a gemologist because of their use in pearl identification. It is possible by means of Laue photographs to distinguish between genuine and cultured pearls.

*Rotating Crystal Method:* This method, and its many variations, such as certain moving film methods, are powerful tools in the hands of the scientist for the determination of the actual arrangement of atoms in space. Experimental techniques and the methods of interpretation

are too advanced to be considered here. In brief, the method consists of rotating a small single crystal in front of an x-ray beam and recording the position of the diffracted x-ray beams on stationary or moving films.

*Powder Method:* One of the most useful techniques in x-ray diffraction work is the powder method, discovered independently by Debye

center of the camera and rotated by means of a small clock motor. The film upon which the positions of the diffracted x-ray beams are recorded is a strip approximately one by eight inches and is forced against the inside wall of the camera. The rod is rotated to insure random orientation of the thousands of tiny particles of which it is composed. The direct, undiffracted x-ray beam

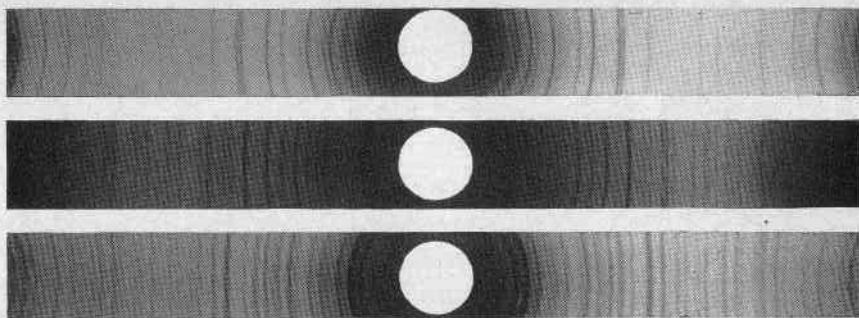

*Figure 3*

*Powder x-ray diffraction photographs taken in the laboratory of the Gemological Institute of America.*

Top: *Corundum (ruby)*

Center: *Quartz*

Lower: *Beryl (aquamarine)*

and Scherrer in 1916 and by Hull in 1917. In the powder method single crystals are not required. If a narrow beam of x-rays is directed at a finely powdered crystalline substance, photographs such as those shown in Figure 3 are obtained.

The type of equipment needed to produce a powder pattern is shown in Figure 4. The material to be examined is reduced to a very fine powder and bonded together with collodion into the form of a rod approximately one millimeter in diameter and one to two centimeters long. The rod is then placed in the

is passed through a central hole in the film. The resultant patterns resemble those shown in Figure 3 when the film is laid out flat.

The advantages of the powder method over other methods are several. Since a single crystal is not required, powder patterns may be made of any crystalline substance. A very small amount of material is required, much less than that needed for a chemical analysis.

Notice that in Figure 3, the patterns of ruby, quartz and emerald are entirely different. This difference is true for *all* crystalline materials.

Hence, a powder pattern is in effect a *fingerprint*, each material giving its own characteristic pattern. The powder method is, therefore, an extremely powerful identification tool, and it is for this purpose that it is most commonly used. Naturally, since a powdered sample is required, the powder method is not satisfactory for identification of fashioned gems, but is extremely useful for rough gem material.

radiograph is a result of selective absorption. Those portions of the object which absorb x-rays strongly, appear light on the film, while portions transparent to x-rays register black on the film. The detail is registered by other parts of the object which absorb x-rays to varying degrees. Thus a radiograph is a shadow, and is not the result of diffraction of the x-ray beam by atomic planes.

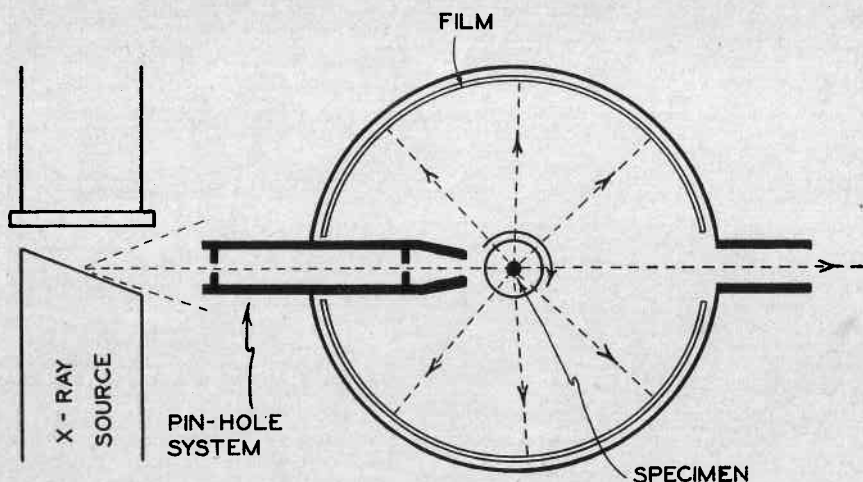

Figure 4  
Diagram of camera used for taking powder photographs

**Radiography:** The technique used in medicine for obtaining the familiar x-ray photographs of broken bones, and in industry for detecting, for example, flaws in castings, is entirely different from those previously described. In radiography the object is placed very near, or in contact with, a piece of film as large as the object. The whole object is then bathed by a broad x-ray beam. The resultant photograph is actually a shadow cast by the object upon the film. The detail exhibited in such a

Radiography is a technique of importance to the gemologist in that it is used to examine pearls to determine whether they are genuine or cultured. The difference in absorptive power of the mother-of-pearl nucleus and the outer nacreous layers is sufficient to register on the film. Hence, in general, a radiograph of a cultured pearl will show the outline of the mother-of-pearl nucleus, while no such nucleus will be visible in genuine pearls. This method, however, has shortcomings which



make it not always positive, and in such doubtful cases Laue-type diffraction patterns must be taken.

Fluoroscopy is a type of radiography in which the shadow cast by the object being examined is viewed directly on a fluorescent screen instead of being recorded photographically.

#### Conclusion

The foregoing material has been presented in order to acquaint the gemologist with the fundamentals of

the production, properties and uses of x-rays. X-rays have been used for a number of years in the identification of pearls, and it is possible that new methods for the identification of other gems by the use of x-rays will be developed in the future.

The use of x-rays in pearl identification will be covered in detail in a forthcoming issue of GEMS & GEMOLOGY.

## GIFTS TO THE INSTITUTE

From Mr. Lawrence Rosenkrantz, Lawrence Gem & Jewelry Co., North Hollywood, the Gemological Institute has received its largest group of genuine stones for use in the instruction of gem identification. The stones, 204 in number, include zircon, sapphire, garnet, quartz and spinel, many with inclusions which are excellent for the teaching of identification by characteristic inclusions.

Dr. Edward Gübelin, C.G., of Lucerne, Switzerland (Sustaining and

Endowment Member and postgraduate student of G.I.A.) recently sent the Institute a group of over 200 excellent colored photomicrographic slides of gemstone inclusions. His first collection of 129 photomicrographic kodachrome slides of inclusions in both genuine and synthetic stones was received in 1943. Dr. Gübelin's success with photomicrography of gems is unparalleled. These slides have proved invaluable to the Institute, and are an outstanding contribution to world gemology.

# GEMOLOGICAL DIGESTS

## The Diamond Industry in 1945

(Condensation of Article by Sidney H. Ball, Ph.D.)

In its 2500 or more years of existence, the diamond industry has never had such a prosperous year as 1945. Production reached an all-time peak, some 14,250,000 carats, the decided increase over recent years being due to marked upturns in output of crushing bort in the Belgian Congo and of gem stones in the Union of South Africa. Notwithstanding this, stocks were further depleted by the fact that the Diamond Trading Company's sales of rough were £24,500,000, a figure never before attained. Demand, for the fourth successive year, greatly exceeded production, and hereafter diamond cutters and users of industrial diamonds must look largely to current production for their raw product, and wholly

so far as some sub-types of it are concerned.

Sales of cut diamonds, in the United States at least, also were of record proportions, due to high wages during the war and to accumulated wartime savings and, during the past four years, to the American stock market boom.

The diamond cutting industry continued its growth, largely through the remarkably rapid revival of the Belgian industry. There are now over 26,000 cutters widely scattered over the world. The industry is geared too high for the amount of gem rough which presumably will be available, and much unemployment is likely to result.

Now that the war is over, the

### World Production of Diamonds

*Production, 1942-5, by Countries, in Metric Carats  
(Including Industrial Diamonds)*

|                            | 1942             | 1943             | 1944              | 1945              |
|----------------------------|------------------|------------------|-------------------|-------------------|
| <b>Africa:</b>             |                  |                  |                   |                   |
| Angola.....                | 791,850          | 794,980          | 800,000           | 786,000           |
| Belgian Congo.....         | 6,018,236        | 4,881,000        | 7,540,000         | 10,386,000***     |
| French Equ. Afr.....       | *20,000          | *20,000          | *5,000            | *5,000            |
| French W. Africa.....      | 1,500            | 35,000           | *60,000           | *60,000           |
| Gold Coast.....            | *1,000,000       | *1,000,000       | *1,000,000        | *500,000          |
| Sierra Leone.....          | *850,000         | *850,000         | *700,000          | *800,000          |
| South-West Afr.....        | 56,420           | *88,000          | 154,000           | 156,000           |
| Tanganyika.....            | 41,000           | 52,998           | 90,667            | 115,666           |
| <b>Union of S. Africa:</b> |                  |                  |                   |                   |
| Mines.....                 |                  | 175,885          | 639,000           | 878,713           |
| Alluvial.....              | 118,821          | 126,444          | 270,000           | 262,527           |
| <b>Total.....</b>          | <b>118,821</b>   | <b>302,329</b>   | <b>909,000</b>    | <b>1,141,240</b>  |
| Brazil.....                | *300,000         | *275,000         | *370,000          | *275,000          |
| British Guiana.....        | 22,208           | 18,272           | 13,911            | 17,251            |
| Other Countries**.....     | 40,836           | 29,650           | 34,000            | 15,000            |
| <b>Grand Total.....</b>    | <b>9,260,871</b> | <b>8,347,239</b> | <b>11,676,578</b> | <b>14,257,157</b> |

\*Estimated.

\*\*Includes Venezuela (12,769 carats); Borneo, India, New South Wales, U.S.S.R.

\*\*\*96% industrial stones.

industry may be congratulated on the fact that at no time during the war were the United Nations short of one of the most important of strategic minerals, the industrial diamond, without the use of which no important munition of war was made; nor was the industry subsidized, nor did it sell its product under a premium price plan. Further, all industrials were sold throughout the war at prewar prices.

**Rough Market**

The Diamond Corporation purchases in normal times 95% of the world's production in dollar value, indeed all production except part of that of Brazil, British Guiana, Venezuela and of some of the South African alluvial diggers. These stones its subsidiary, the Diamond Trading Company, sells to brokers and cutters. The Diamond Corporation has £5,000,000 in ordinary shares, 80%, it is understood, being owned by De Beers and 20% by Consolidated Diamond Mine of South-West Africa. The Diamond Trading Company's capital (£3,000,000) is wholly invested in rough diamonds and as sales are made the proceeds are re-invested in rough. The Diamond Corporation's report is available only to its stockholders but the firm pays in good years, it is understood, handsome dividends. (1944 Diamond Corp., 10%, and Diamond Trading Co., 12½%.)

As late as 1934 total sales of the Diamond Trading Company were only £3,719,242, a year of depression

in the industry and one in which few industrial diamonds were sold.

The value of cut stones per carat increases with the size of the stone. In first qualities the increase is of the following order, the per-carat price of a one-carat stone being taken as 100% :

|                |      |
|----------------|------|
| 2 carats.....  | 145% |
| 4 carats.....  | 265% |
| 6 carats.....  | 330% |
| 8 carats.....  | 380% |
| 12 carats..... | 450% |

**United States Imports**

The total gem diamond imports, in dollar value, for the years 1941 to 1945 follow:

|           |              |
|-----------|--------------|
| 1941..... | \$28,647,786 |
| 1942..... | 26,186,948   |
| 1943..... | 68,127,004   |
| 1944..... | 72,670,146   |
| 1945..... | 107,308,028  |

These import figures suggest how prosperous the diamond industry has been in the past three years.

In 1945 the production from the Union of South Africa was about as follows:

|                            | <i>Carats</i> | <i>Ave. Price</i> | <i>Value</i> |
|----------------------------|---------------|-------------------|--------------|
| Pipe mines.....            | 878,713       | 88s. 4d.          | £3,881,482   |
| Old alluvial diggings..... | 56,379        | 142s. 7d.         | 401,873      |
| Namaqualand                |               |                   |              |
| . . . Est.....             | 206,150       | 129s.             | 1,330,000    |
|                            | 1,141,242     | 98s. 4d.          | 5,613,355    |

The two operating De Beers pipe mines, Bulfontein and Dutoitspan, furnished practically all of the mine production, although nine other pipes were responsible for a few carats. Alluvial production was also distinctly greater than in 1944.

**Total Sales in Recent Years of Diamond Trading Company**

| <i>Year</i>       | <i>Total Sales</i> | <i>Gem Stones</i> | <i>% of Total</i> | <i>Industrials</i> | <i>% of Total</i> |
|-------------------|--------------------|-------------------|-------------------|--------------------|-------------------|
| 1939.....         | £ 5,865,000        | .....             | .....             | .....              | .....             |
| 1940.....         | 6,144,314          | .....             | .....             | .....              | .....             |
| 1941.....         | 7,414,420          | £ 5,500,000       | 74                | £2,000,000         | 26                |
| 1942.....         | 10,694,671         | 6,250,000         | 59                | 4,240,000          | 41                |
| 1943.....         | 20,400,634         | 14,973,000        | 73                | 5,428,000          | 27                |
| 1944 (Est.).....  | 17,000,000         | 13,000,000        | 76                | 4,000,000          | 24                |
| 1945 (About)..... | 24,500,000         | 19,600,000        | 80                | 4,900,000          | 20                |

### Tanganyika Territory

The most interesting development in diamond production is the sudden prominence of Tanganyika as a source. Recent press reports indicate the discovery of a tremendous "pipe" in the territory.

Tanganyika Territory found its first diamond in 1910 or thereabouts and, while a few stones were recovered from 1921 to 1925, the first real production began in 1926 (6,695½ carats) and by 1928 had reached 24,680¾ carats. Production then slumped and in 1932 it was but 1,387 carats. In the late thirties production slightly increased and in 1941 it jumped to 29,046 carats and in 1943 to 52,998 carats, due to new discoveries in the Shinyanga district. Since then exports (to all intents and purposes, production) have increased as the following figures show:

|                                      |               |
|--------------------------------------|---------------|
| 1st ½ of 1944.....                   | 42,000 carats |
| 2nd ½ of 1944.....                   | 48,067 carats |
| Average price per carat 65s. 9.25d.  |               |
| 1st ½ of 1945.....                   | 61,818 carats |
| 2nd ½ of 1945.....                   | 53,848 carats |
| Average price per carat 125s. 6.13d. |               |

The 1945 exports (and produc-

tion) totalled 115,666 carats, worth £725,759.

Some of the stones are large; for example, in 1944 a 67 and a 120-carat gemstone were found, and the average size is almost 1 carat. Good gemstones are produced, also excellent industrials. The gravels are associated with kimberlite pipes, but not necessarily with the pipe in which the gravel occurs, the control apparently being that the readily eroded pipe forms a depression, entrapping the gravel. While some of the pipes contain diamonds none carry a commercial content. (Written before recent press releases.)

The diamonds come largely from two localities, Mabuki and Kisumbi (near Shinyanga); of lesser importance are Usongo and the Lake Prospect.

The new Tanganyika development and the reopening of the Premier and other "pipe" mines scheduled for 1947 alters the gem production outlook considerably. By 1948 or 1949, the gem diamond situation should be measurably improved.

*Richard T. Liddicoat, C.G.*

### Wyoming "Jade"

To check the authenticity of a recent newspaper report of a new "jade" deposit at Kemmerer, Wyoming, the Gemological Institute of America wrote to the Geological Survey of Wyoming. Mr. Horace D. Thomas, Wyoming State Geologist, replied that specimens of the Kem-

merer material had been examined and were determined to be chert (quartz).

Specimens of what had been reported to be jade from Wyoming were recently examined in the laboratory of the Gemological Institute and proved to be fine green quartzite.

# Identification of Synthetic Gems

## Part I—The Detection of Synthetic Corundum

by

RICHARD T. LIDDICOAT, C.G.

*Director of Education, Gemological Institute of America*

Several articles on synthetic gems have appeared in this publication in the past few years. This paper is intended as a summary of the methods used to detect present day synthetic gems.

Although only three gem species have been synthesized, many others are still incorrectly sold as synthetic counterparts of gems. To be classified as a synthetic, a gem must have the same chemical constituents and the same atomic structure as the

gem it represents. The only true synthetic gems are synthetic corundum (ruby and sapphire), spinel, and beryl (emerald only). The synthetic alexandrite, zircon, garnet and aquamarine sold in the trade are not what the name implies, but synthetic corundum or spinel, incorrectly named. As such, they are easily identified by the difference in their properties from those of the natural alexandrite, zircon, garnet and aquamarine.

Photo by Dr. Gübelin

*Figure 1*  
*"Fingerprint" inclusion in natural sapphire. Straight zoning structure and black fractures extending from zircon inclusions are also prominent.*

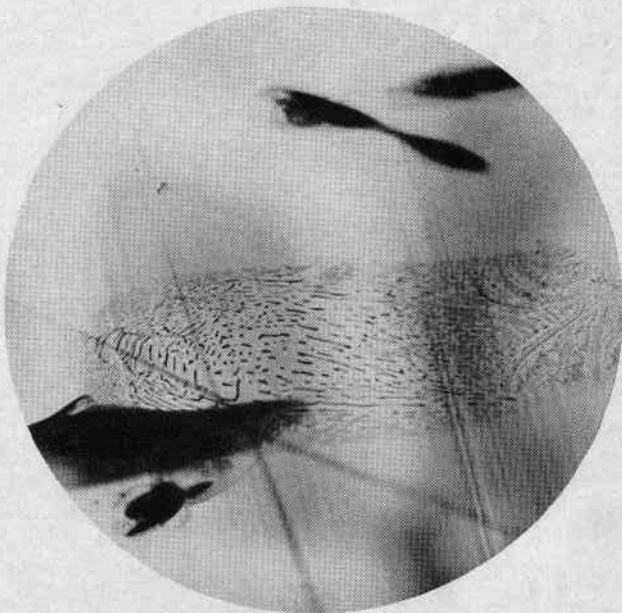

Since a stone to be correctly called synthetic must have the same optical and other physical properties as the natural gem it represents, the ordinary tests used to distinguish between gem species are useless. We can no longer depend upon such standby methods as the determination of refractive index and specific gravity since synthetic and natural corundum have the same refraction and density. How, then, is the positive identification accomplished?

The foolproof method of distinguishing between genuine and synthetic corundum depends upon careful examination of the inclusions found within the gem. Since completely flawless corundum, whether of natural or man-made origin, is almost unknown, detection by means of inclusions is the sure method available to the gem tester. Spherical bubbles prove synthetic origin, while

angular liquid or crystal inclusions are proof of genuine origin.

The angular imperfections of corundum of natural origin take several forms. Liquid inclusions in planes in rubies and sapphires often have an arrangement that gives them the appearance of a fingerprint (See Figure 1). "Fingerprints" are characteristic of natural ruby and sapphire. Small grains of zircon included within corundum have fractures extending from them that resemble black halos. In the center of the black area, a bright point of light can usually be seen in the zircon (See Figure 2). So-called "silk" is another distinctive feature of natural corundum. "Silk" is probably made up of long slender needle-like crystals of the mineral rutile. The needles form three parallel groups which intersect at angles of 60 degrees (Figures 3 and 4). Growth

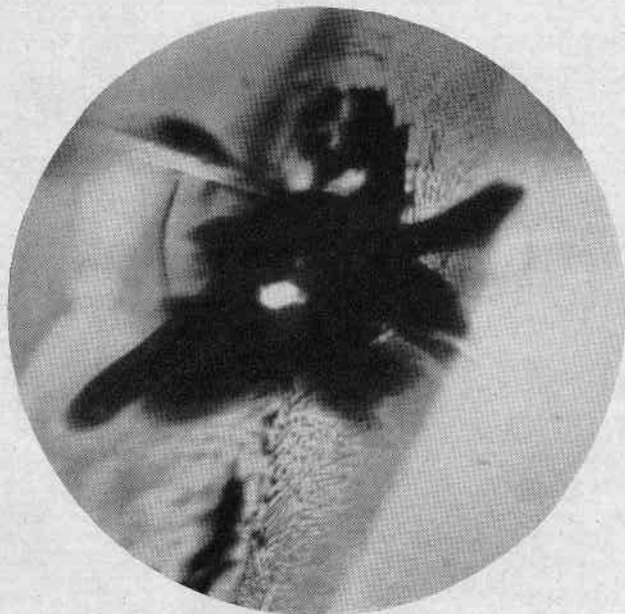

Photo by Dr. Gübelin

*Figure 2*  
*Bright spot of light coming through zircon surrounded by black halo. "Fingerprint" inclusion in the background of a natural Ceylon sapphire.*

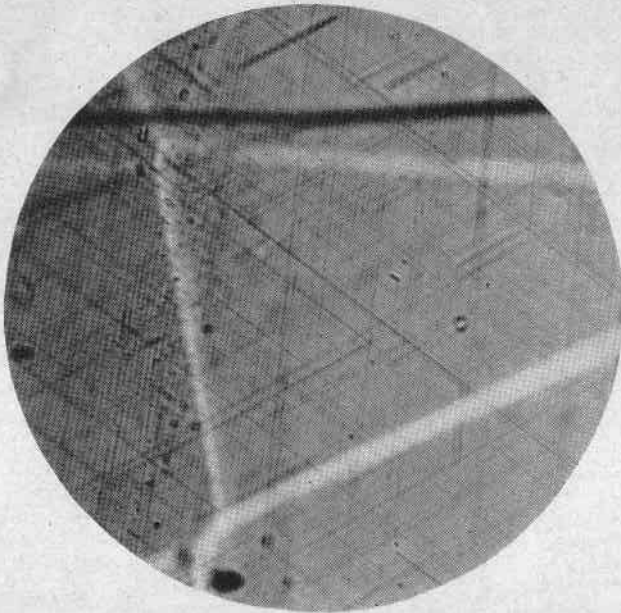

Photo by Dr. Gübelin

*Figure 3*  
"Silk," in the usual  
pattern of parallel  
groups intersecting  
two other parallel  
sets at 60° angles in  
a Ceylon ruby.

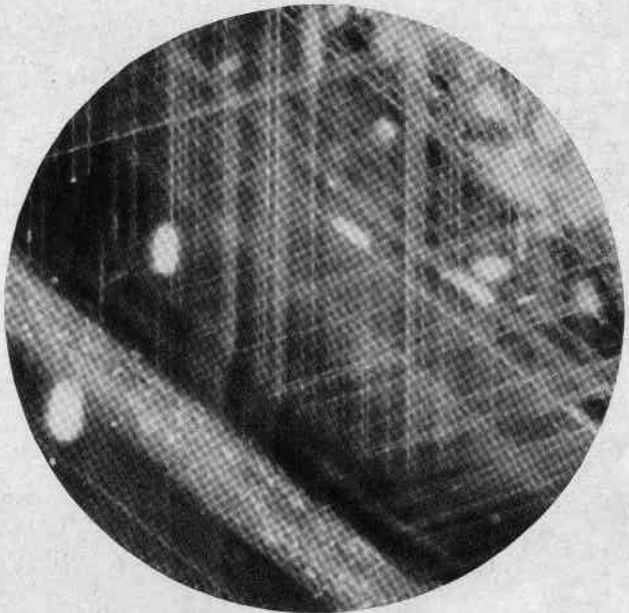
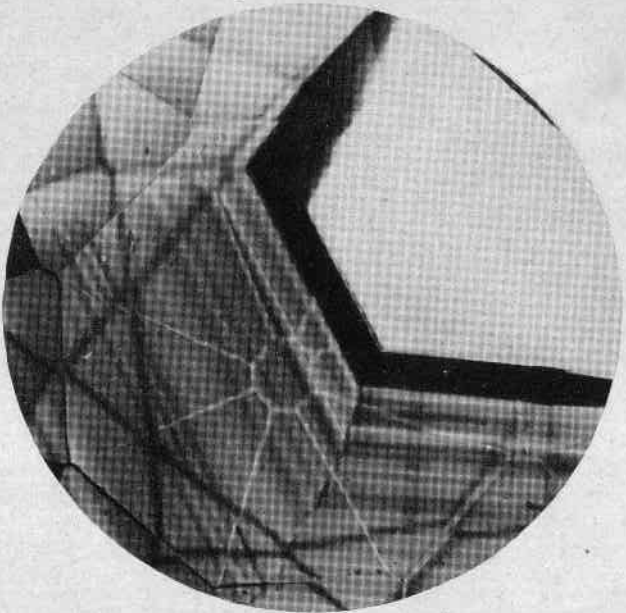

Photo by Dr. Gübelin

*Figure 4*  
"Silk" as seen by  
dark-field illumina-  
tion in a G.I.A.  
DIAMONDSCOPE.

Photo by Dr. Gübelin



*Figure 5*  
*Hexagonal zoning,*  
*or growth structure*  
*in a genuine sapphire.*

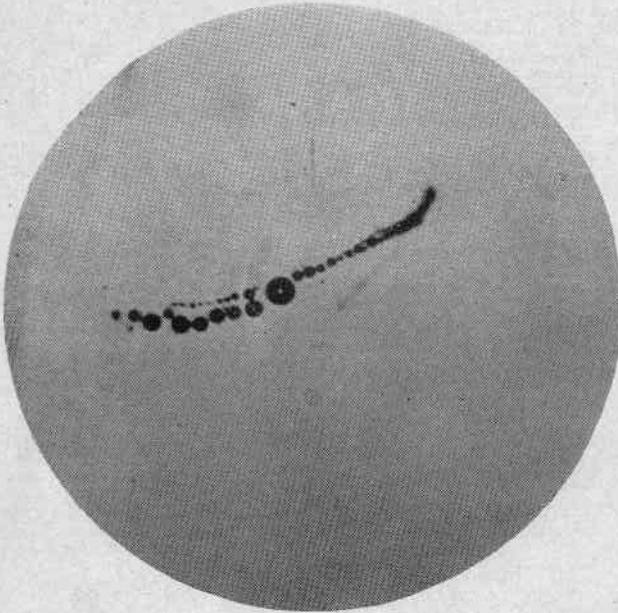
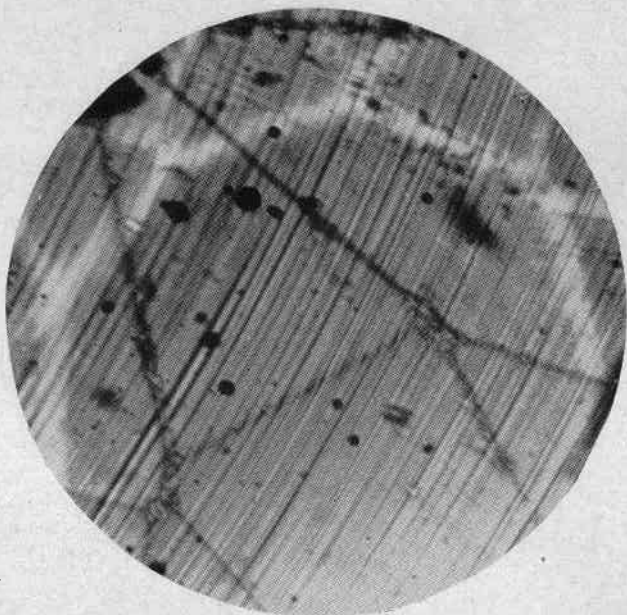

Photo by Dr. Gübelin

*Figure 6*  
*Row of spherical*  
*bubbles in a syn-*  
*thetic ruby.*



Photo by Dr. Gübelin



*Figure 7*  
*Spherical bubbles*  
*and curved striae in*  
*a synthetic ruby.*

bands are often in evidence as color bands arranged in the hexagonal pattern of corundum (Figure 5). The presence of any or all of these characteristic natural ruby or sapphire inclusions or other angular inclusions constitutes proof of natural origin.

Synthetic ruby and sapphire are characterized by spherical gas bubbles, and, less often, by curved growth lines. The presence of either spherical bubbles or curved stria is proof of synthetic origin (Figures 6, 7 and 8). Gas bubbles are frequently elongated, having moved apparently just before the molten material solidified. However, they retain a round cross-section.

When inclusions are large and easily seen, there is no difficulty in determining the origin of the gemstone. Gems that approach flawlessness, however, present problems that

are less simply overcome. Many synthetics cannot be positively identified by the use of a loupe. Higher magnification and more efficient lighting of the gem is necessary to resolve adequately the inclusions that will testify to its origin. In extreme cases, where no imperfections become visible to the gem tester, it becomes necessary to immerse the gem in liquid to reduce surface reflection from the facets.

The detection of curved striae in synthetic corundum very often requires immersion as well as careful light control. Curved striae are formed as the synthetic ruby or sapphire boule grows by the addition of molten material at the top of the boule. Since the large majority of synthetic stones are oriented with the table parallel to the long axis of the boule, curved striae are commonly visible through the table.



Photo by Dr. Gübelin

*Figure 8*  
*Curved growth striations with spherical and elongated bubbles in synthetic ruby.*

Because growth lines in genuine corundum are oriented parallel to the faces of the hexagonal prism and the tables are usually across the length of the rough crystal, growth lines in natural ruby and sapphire are commonly visible through the table.

If, upon the initial examination of the gem under magnification no striae are noted, the tester should change the source of light by first stopping it down to as narrow a beam as possible. If this fails to resolve striae, further steps are

necessary. The direction from which the light enters the stone must be varied, as well as the direction in which the gem is examined. Immersion of the gem will assist materially in the resolution of striae or growth lines.

With practice, the gem tester will find that almost all synthetic ruby and sapphire will display striae and thereby classify their origin beyond question, but the classification of the gem's inclusions is the quick and exact method upon which most gem testers rely.

*(Part II will appear in next issue.)*

## DIAMOND GLOSSARY

(Continued from Page 335 of last issue)

- portrait stone.** A thin plate of diamond, shaped and polished for use in covering miniatures or other small portraits in rings, brooches, etc. Sometimes faceted. See **Table Diamond**.
- Portugal diamond.** A "round brilliant" mentioned by Murray in 1839.
- Portugal, Regent.** See **Regent of Portugal Diamond**.
- Portuguese, West Africa.** A name sometimes used for **Angola**, a diamond-producing country.
- Portuguese cut.** An obsolete style of brilliant cut which had three rows of triangular facets and two rows of rhomboidal facets on both crown and base.
- pothole.** A circular hole worn into solid rock by waterfalls or whirlpools by the churning action of water on loose stones and sand. Usually greater in depth than in width. Heavy minerals, like diamond, tend to remain as concentrates and after the stream bed is covered with dirt the pothole in an area of diamond-bearing gravels contains exceptionally valuable deposits. See **kettle hole**, **swallow hole**, **sink**.
- powder.** A term sometimes used as an abbreviation of **diamond powder** or **dust**.
- premier.** A trade term for a color grade of diamonds which have an oily or greasy body appearance and appear bluish in sunlight and yellowish in ordinary artificial light. Because of trade prejudice often valued less than the latter color. So named because the **Premier Mine** was the principal source. Once frequently encountered, the premier had by 1941 become a rarity. Gemologically it is the most spectacular variety of *fluorescent diamond*, the change of color being due to **fluorescence**. Like all such diamonds, its fluorescence is immediately revealed by the standard type of **Diamolite**. See **Premier Mine**.
- Premier Diamond.** A name sometimes used for the **Cullinan Diamond** for a short time after its discovery.
- Premier (Transvaal) Diamond Mining Company, Ltd.** Registered with government Dec. 1, 1902. Apparently announced discovery of **Premier Mine** in 1903. After a marketing agreement with **De Beers** (1907-08) output of mine was sold through a single organization. From 1916 the **Diamond Syndicate** controlled the output and in 1922 control of the company was acquired by **De Beers Consolidated Mines, Inc.**
- Premier Mine.** (1) The name originally given to the **Wesselton Mine**. References previous to 1903 are to this mine. (2) After 1903 the term referred to the mine 23 miles northeast of Pretoria owned by the **Premier (Transvaal) Diamond Mining Co., Ltd.**, of which **Thomas Cullinan**, the discoverer of the mine, was Chairman of the Board. Discovered Nov. 1902 on the farm **Elandsfontein**, it cost £52,000. In 1905 its production

reached 24,000 loads per day, and although diamonds of inferior color, this large output reduced the world price of diamonds and resulted in a price agreement with the Diamond Syndicate. Operations were halted in 1930 and the mine temporarily closed in 1932 having produced £32,000,000 of diamonds. The only important diamond mine in the Transvaal, it seems to consist of overlapping diamond pipes or craters covering a surface area 2900 feet long and 1400 feet wide. When over 600 feet in depth, had shown no contraction in the walls of the pipe (A. F. Williams). Alone of the big South African diamond pipes it was an open-worked mine, and unless the new Tanganyika mine proves greater, is still the largest diamond mine ever known. In 1945 the reopening of the mine was authorized and the removal of water begun with expectation that mining operations could begin in 1947. Its yield of gem diamonds ran to light brown to white stones and industrial diamonds. It produced the great **Cullinan Diamond**. See also **Premier (Transvaal) Diamond Mining Co., Ltd.**

**premier ollie.** Same as premier.

**Presidente Vargas Diamond.** Same as **Vargas Diamond.**

**primary mineral.** A mineral that retains its original form and composition, as opposed to a **secondary mineral**. In *Kimberlite* A. F. Williams differentiates between the primary minerals which are olivine, phlogopite, ilmenite, perovskite, magnetite, apatite and nickel and "transported minerals of pri-

mary origin," which include garnet, zircon, spinel, enstatite, rutile, etc.

**Prince Edward of York Diamond.** A fine, white, pear-shaped, 60¼ carat African stone imported into U.S.A. in 1901 by Alfred H. Smith and Co., and sold to a New York banker. (Cattelle.)

**Princess Mathilde Diamond.** A diamond said to have once belonged to Abdul Hamid II, Sultan of Turkey and sold in 1933 by the Mont de Pieté of Paris.

**proper proportions (of fashioned diamonds).** *In general*, the proper proportions for maximum brilliancy depend upon (1) the relative proportion of the mass above and below the girdle and (2) the angles of the pavilion facets in relation to the plane of the girdle and (3) to a lesser extent, the angle of the crown facets to that plane. Proper proportions for maximum "fire" depend upon the same factors but especially upon the angle of the crown facets and the width of the table. Large tables reduce total fire. In **emerald cut** diamonds maximum fire is of less importance than in **brilliant cut**. The theoretically ideal proportions for **brilliant cut** diamonds established by **Tolkowsky** are generally accepted and are:

|                                  |        |
|----------------------------------|--------|
| Diameter of girdle.....          | 100%   |
| Diameter of table.....           | 53%    |
| Total thickness of stone.....    | 59.3%  |
| Thickness of crown.....          | 16.2%  |
| Thickness of pavilion.....       | 43.1%  |
| Angle of bezel facets.....       | 34°30' |
| Angle of pavilion facets.....    | 40°45' |
| Angle of upper break facets..... | 42°    |
| Angle of lower break facets..... | 42°45' |
| Angle of star facets.....        | 15°    |

(To Be Continued)